

UC-NRLF

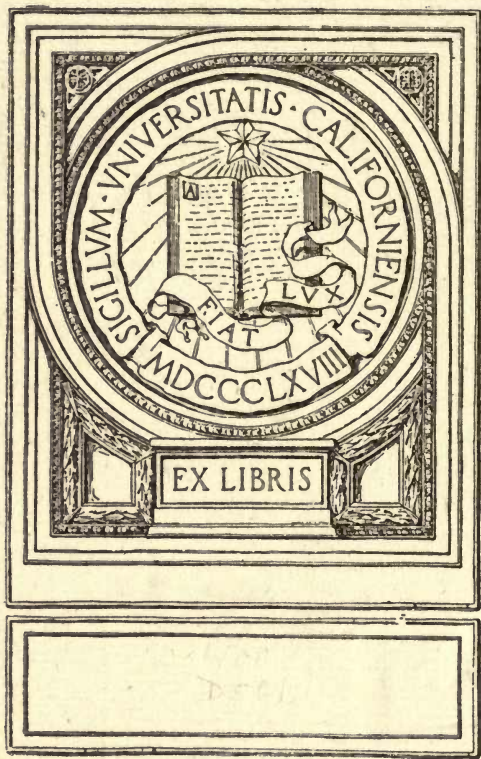

B 4 586 931



B 436 J

~~John~~
25 10 John
College



7637
150

381950

7637

11458110





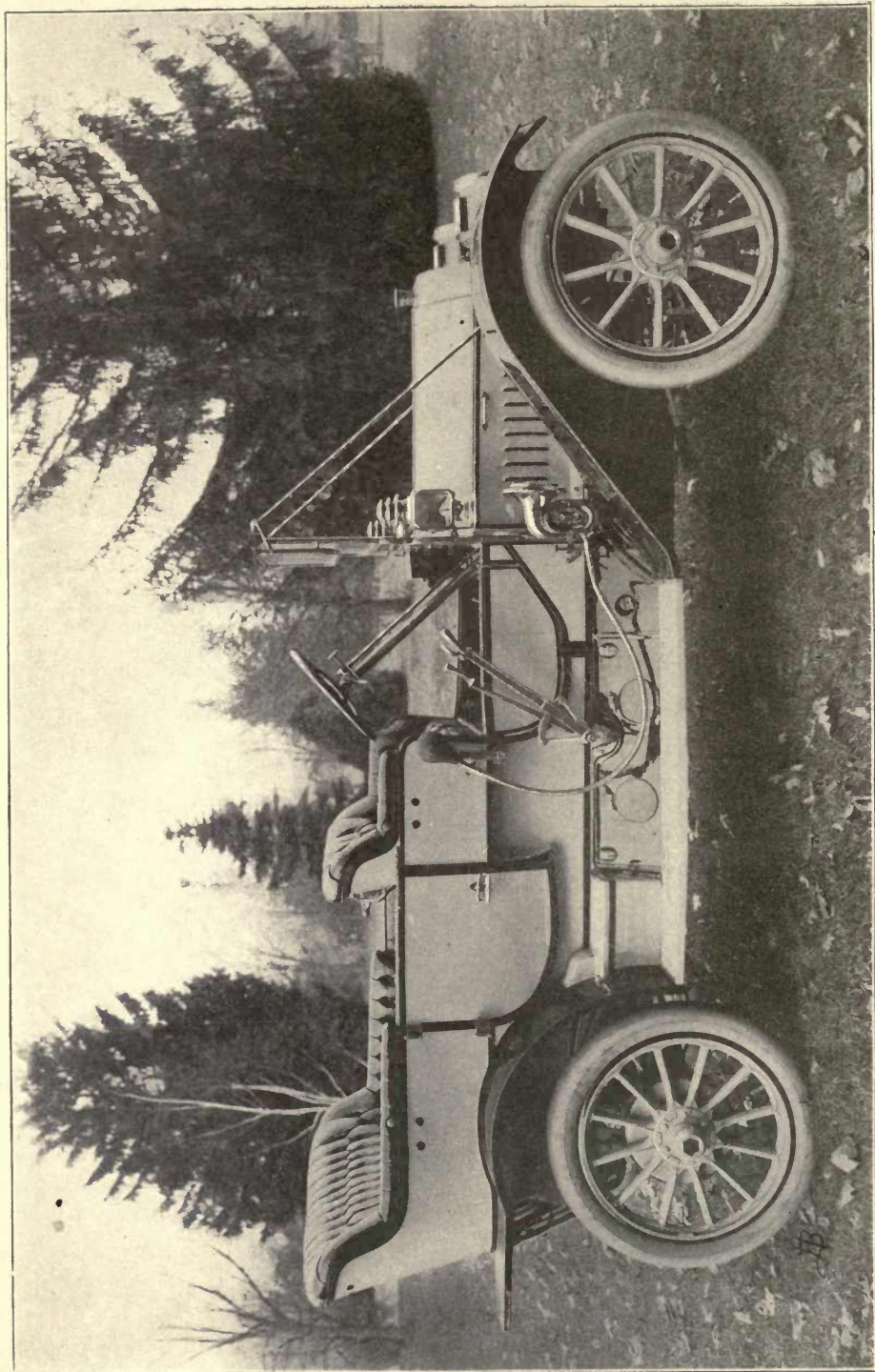

OLDSMOBILE TOURING CAR, MODEL D.
Olds Motor Works, Lansing, Mich.

Automobiles

A Practical Treatise on the

CONSTRUCTION, OPERATION, AND CARE OF GASOLINE, STEAM, AND
ELECTRIC MOTOR-CARS, INCLUDING MECHANICAL DETAILS OF
RUNNING GEAR, POWER PLANT, BODY, AND ACCESSORIES,
INSTRUCTION IN DRIVING, ETC.

By HUGO DIEMER, M. E.

Professor of Mechanical Engineering
The Pennsylvania State College
State College, Pa.

ILLUSTRATED

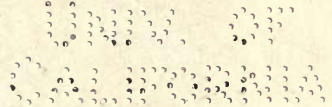

CHICAGO
AMERICAN SCHOOL OF CORRESPONDENCE
11
1909

TL145
A5

GENERAL

COPYRIGHT 1909 BY
AMERICAN SCHOOL OF CORRESPONDENCE

Entered at Stationers' Hall, London
All Rights Reserved

TO VIND
ALIBORUAS

Foreword

WITHIN recent years the self-propelled vehicle has become so important a factor in the evolution of social and business life, that a distinct need has been created for a comprehensive but concise treatise, written in clear and simple language, which shall serve as a *practical working guide* to all details of the construction, care, and successful operation of the various types of motor-cars. It is the purpose of the present volume to fill this acknowledged need.

☞ The application of the internal-combustion motor, the steam generator, and the storage battery to the development of types of mechanically propelled road-carriages fitted to meet all the trying conditions of the use to which such vehicles are put, is a far-reaching engineering problem of great difficulty. While not all details of this problem have as yet been finally worked out or reduced to standard practice, sufficient progress has been made to assure results of permanent value. In so far as these results are embodied in the constructions used in typical modern cars, they are presented in these pages without any attempt at refinement of engineering subtleties, but with all explanation of essential details of construction and operation needed by those who drive their own machines or who wish to qualify as practical chauffeurs.

¶ Special stress is laid on the *practical* as distinguished from the merely theoretical or descriptive form of treatment, so that the work will be found especially adapted for purposes of self-instruction. It is designed not only to meet the requirements of a manual of practical instruction for the novice, but also to serve as a reference work replete with information and suggestions of the utmost practical value to the most experienced driver.

¶ The method adopted in the preparation of this volume is that which the American School of Correspondence has developed and employed so successfully for many years. It is not an experiment, but has stood the severest of all tests—that of practical use—which has demonstrated it to be the best method yet devised for the education of the busy workingman.

¶ For purposes of ready reference and timely information so frequently needed in automobile operation, it is believed that this volume will be found to meet every requirement.

HUGO DIEMER.

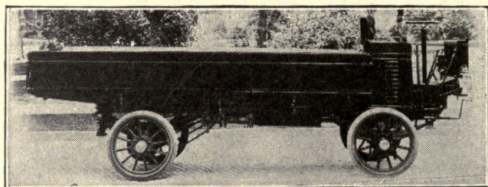

Table of Contents

COMPONENT PARTS OF A MOTOR-CAR Page 1

Running Gear (Wheels, Tires, Axles, Springs, Frame, etc.)—Power Plant (Engine, Clutch, Transmission, etc.)—Body (Wood, Steel, Aluminum)—Motor Suspension (Three-Point, Four-Point)—Springs (Half- and Full-Elliptic)—Front Axles (Solid, Tubular)—Rear Axles (Live, Dead, Floating, etc.)—Steering Yoke, Neck, and Knuckle—Steering Column (Screw-and-Nut, Worm-and-Gear, Worm-and-Sector)—Hand-Wheel

POWER PLANT OF A GASOLINE CAR Page 17

Gas-Engine Cycle (Admission, Compression, Ignition, Exhaust)—Four-Cycle and Two-Cycle Engines—Piston and Valve Action—Working Parts of Engine—Single- and Multiple-Cylinder Engines—Separately Cast Cylinders—Cylinders Cast in Pairs—Engine Parts (Cylinders, Pistons, Crank-Shaft, Cams and Cam-Shafts, etc.)—Valve-Setting—Poor Compression—Corrosion in Cylinders—Cooling Systems (Air, Water)—Revolving-Cylinder Motor—Water Jacket—Radiators (Tubular, Cellular)—Thermo-Siphon Method of Circulation—Gaskets—Overheating of Engine—Air-Lock—Steaming Radiators—Cold-Weather Precautions—Anti-Freezing Mixtures—Gasoline System (Tank, Piping, etc.)—Sediment and Water Receptacle—Gauge-Glasses—Grades of Gasoline—Use of Kerosene—Carbureters—Gasoline and Air Mixture—Automatic Regulation—Float-Feed Carbureter—Compensating Carbureter—Connecting and Adjusting a Carbureter—Dry-Cell and Jump-Spark Ignition—Trembler or Vibrator—Spark-Coil Adjustment—Spark-Timer or Commutator—Direct-Current Shunt-Wound Dynamo Ignition—Magneto Ignition—Spark-Plugs—Make-and-Break Ignition—Storage Batteries for Ignition

CONTROLLING MECHANISM AND TRANSMISSION Page 79

Spark-Lever—Early and Late Spark—Throttle-Lever—Pedals—Muffler Cut-Out and Compression-Relief Levers—Power Transmission—Clutches (Constriction-Band, Cone, Single- and Multiple-Disc)—Speed-Changing Gears—Planetary Gears—Sliding Gears—Speed-Changing and Brake Levers—Changing Gears—Grinding Gears—Running on High-Speed Gear—Transmission or Drive Mechanism (Single- and Double-Chain, Shaft, Friction, Cable)—Universal Joints—Differentials or Balance Gears

CARE AND OPERATION OF MOTOR-CARS Page 106

Lubrication—Hot Boxes—Force-Feed Lubricators—Brakes (Ordinary and Emergency)—Brake-Bands (Internal and External)—Bearings (Cylindrical, Roller, Ball, Annular)—Inspection of New Car—Starting Engine—Speed-Control—Loss of Power—Engine Stopping or Knocking—Weak Batteries—Back-Firing—Smoke—Skidding—Going down Hill—Inspection on Road—Cleaning and Washing—Care of Tires—Inflation—Weights on Tires—Removing and Replacing Tires—Punctures—Electric Vehicles—Care of Motor—Charging and Care of Batteries—Steam-Driven Vehicles

SELECTION AND CLASSIFICATION OF MOTOR-CARS Page 155

Taking Advice—Standing of Manufacturers—Price—Second-Hand Cars—Demonstrations—Horse-Power and Weight—Easy Riding—Accessibility of Parts—Instruction in Driving—Range of Speed—Chauffeurs—Clothing—Top—Accessories (Lights, Dynamos, Tools, etc.)—Classification (Passenger and Commercial, Light- and Heavy-Weight, Runabout, Coupé, Touring Car, Truck, etc.)—Purposes of Various Types

INDEX Page 187

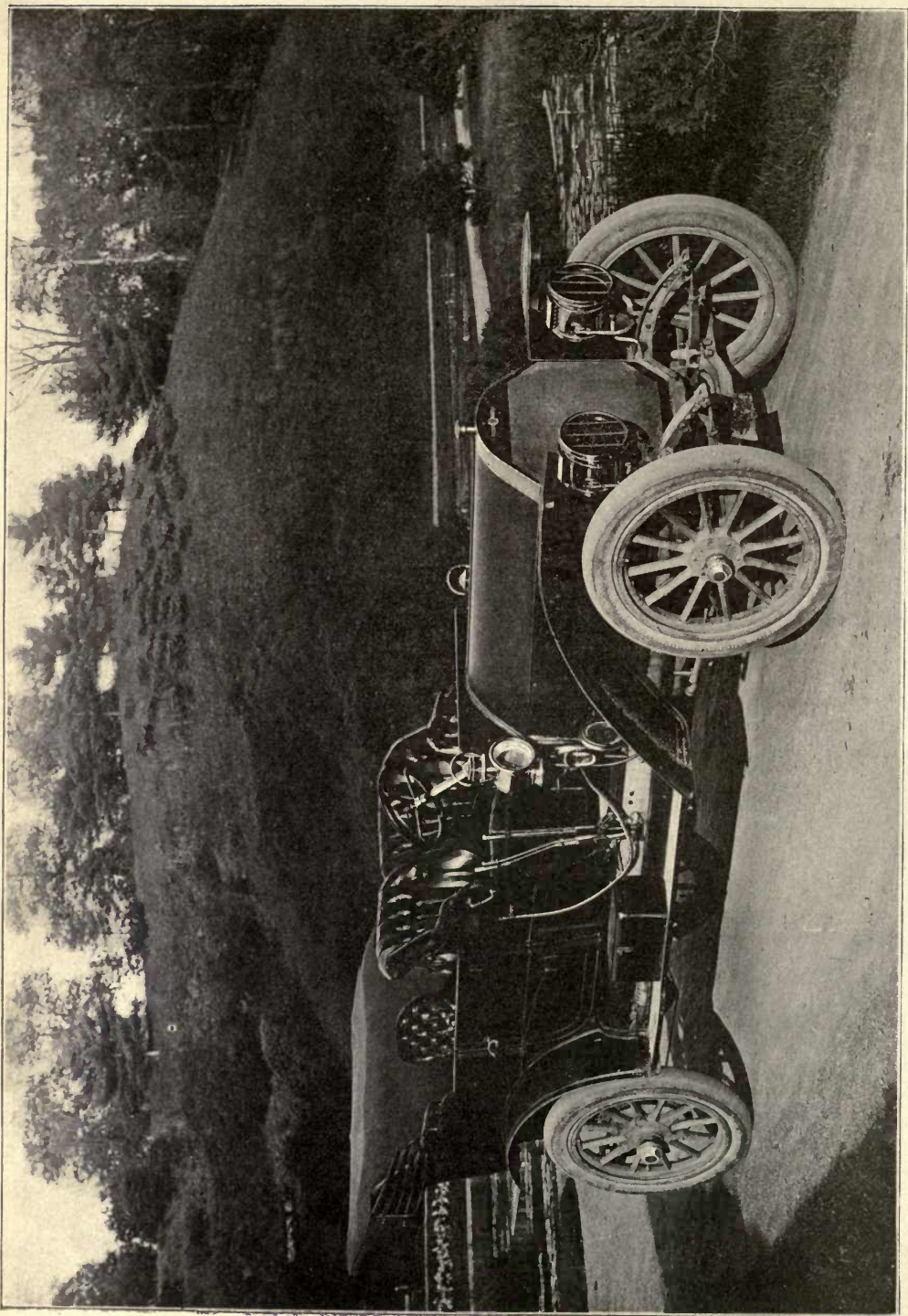

'BIG SIX' TOURING CAR, MODEL Y.
Stevens-Duryea Company, Chicopee Falls, Mass.

AUTOMOBILES

PART I

In attempting to study the operation and function of the various parts constituting the automobile, the best plan is, first, to analyze the machine into its distinct groups of parts, and then to determine the function of each part in each group.

COMPONENT PARTS OF A MOTOR-CAR

The essential parts of the automobile may be broadly classified under three main heads—namely:

- (a) The Running Gear;
- (b) The Power Plant;
- (c) The Body, its Accessories and Fittings.

THE RUNNING GEAR

The running gear (Fig. 1) consists of: *Wheels (A)*, for supporting and propelling the whole machine; *Tires (B)*, for cushioning the car from rough shocks and jars, and for providing a sufficient adhesion

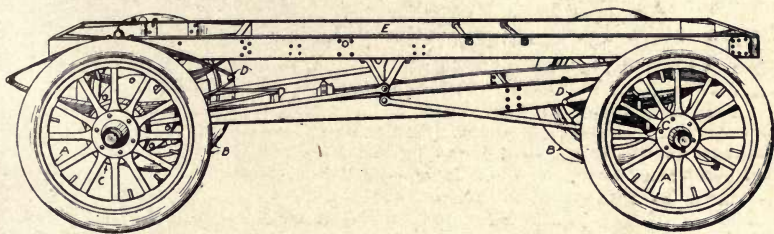

Fig. 1. Running Gear of a Motor-Car.
A—Wheels; B—Tires; C—Axles; D—Springs; E—Frame.

of the wheels to the roadway to insure the friction necessary for propulsion when the wheels are rotated; *Axles (C)*, to carry the wheels and maintain them in correct relative position; *Springs (D)*, to eliminate more completely the shocks and jars; *Frame (E)*, to which all the above parts of the vehicle are attached in the best possible

location, such frame being capable of sustaining the loads to be carried. In addition to the above features shown in Fig. 1, the running gear (see Fig. 2) includes *steering devices* (controlled by hand-wheel, shown at upper right), for altering the direction of move-

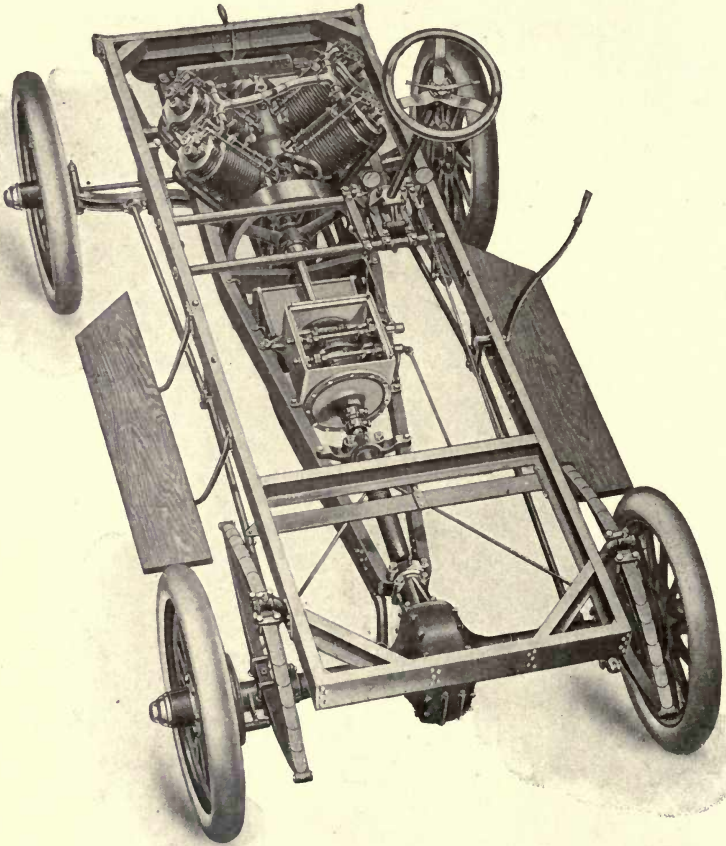

Fig. 2. Typical Chassis of a Motor-Car, Showing Running Gear and Power Plant. Nordyke & Marmon Company, Indianapolis, Ind.

ment of the vehicle; *equalizing mechanism* or *differentials* (generally housed, as shown at center of rear axle), for permitting one driving wheel to turn faster than the other when the machine is turning a curve; *change-speed devices* (ordinarily controlled by hand-lever, shown between front and rear wheels at right), for altering the speed

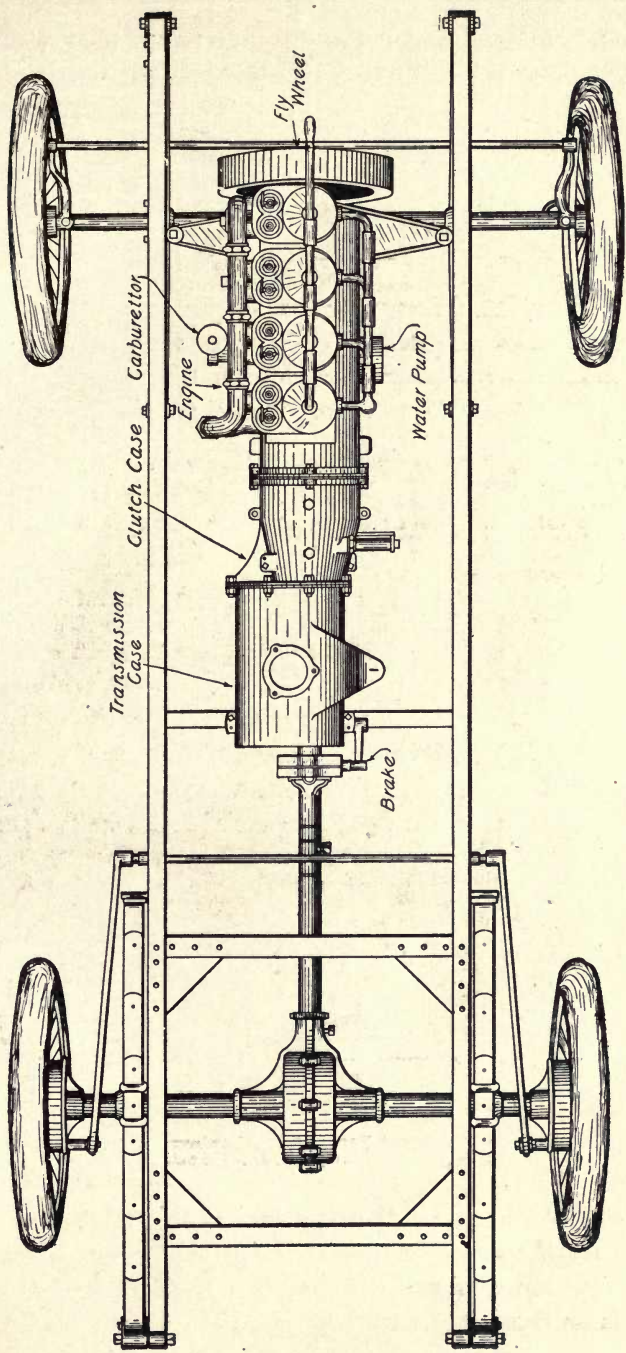

Fig. 3. Power Plant of a Gasoline-Driven Car.
Stevens-Duryea Company, Chicopee Falls, Mass.

of the vehicle while that of the engine may be left unchanged; and *brakes* (ordinarily operated by foot-levers, shown under steering wheel), for bringing the vehicle to a gradual or immediate stop.

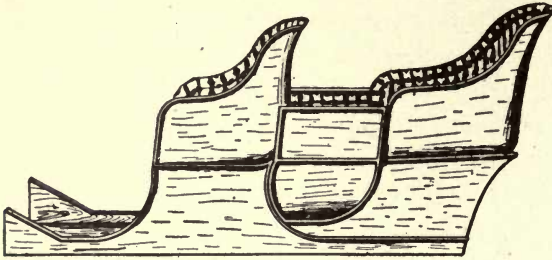

Fig. 4. Wood Body.

Carbureter, Clutch, Transmission, and Water-Pump, as shown in Fig. 3. In addition to these parts, the power plant of the gasoline-driven car includes: *Batteries, Spark-Coils, Spark-Plugs, Oiling*

Power Plant.
The power plant, in the case of the gasoline-driven car, consists of the *Engine, Fly-Wheel,*

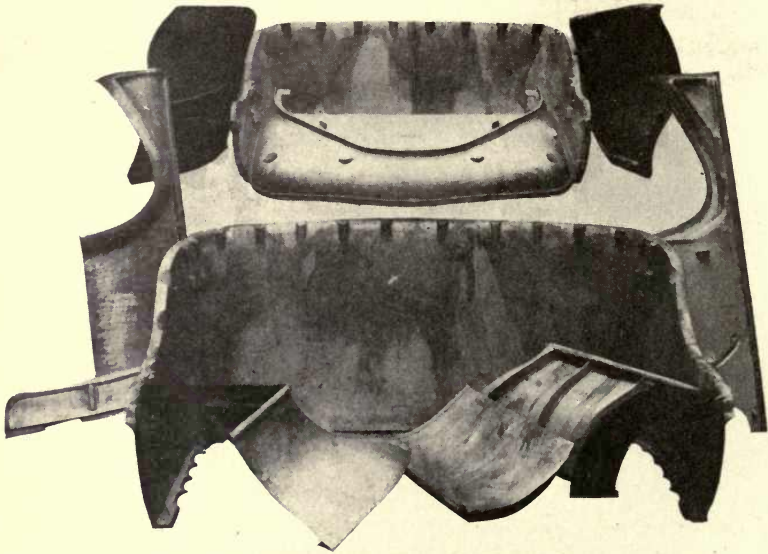

Fig. 5. Component Parts of an Aluminum Body.
Nordyke & Marmon Company, Indianapolis, Ind.

Devices, and other features discussed in detail as to their operation under subsequent headings. The power plants of steam-driven and electrically driven cars are also described in detail in chapters devoted to these types.

Body. The body may be either of wood, of pressed steel, or of cast aluminum. The various styles of bodies are classified and described later.

As to materials, solid wood or veneered wood bodies (Fig. 4) are both liable to cracking and warping, due to exposure to the weather. The pressed-steel body is liable to dents. Aluminum bodies (Fig. 5) are usually cast in separate pieces, and finished with wood seats. Taken all in all, the cast aluminum body is best. It is not usually furnished, however, in the cheaper types of car at present.

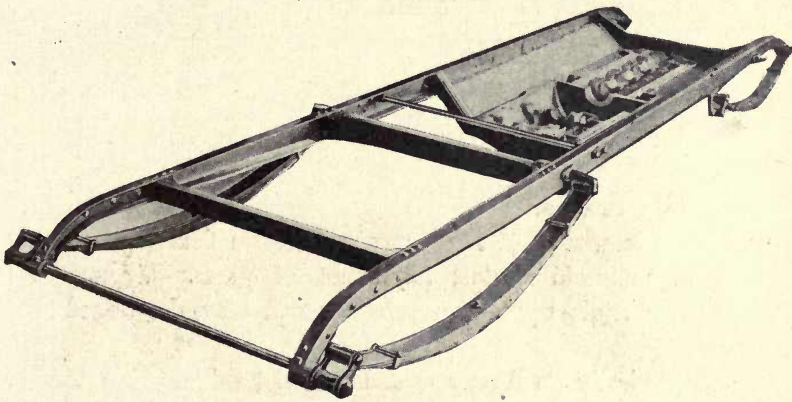

Fig. 6. Pressed-Steel Frame, with Pressed-Steel Motor and Gear Case Support which Acts as Bracing at Weakest Part of Frame. Corbin Motor Vehicle Corporation, New Britain, Conn.

The Frame. Pressed steel is to-day practically the universal material for automobile frames. The name "pressed steel" arises from the fact that the steel is cut from sheets which are placed between dies and forced into shape by heavy presses. This pressing is always done while the steel is cold, since, if the metal were heated, it could not be maintained at a uniform temperature in the presses, and would warp. Moreover, the scale would have to be removed for the sake of good appearance of the frame.

Fig. 6 shows a pressed-steel frame as constructed by the Corbin Motor Vehicle Corporation, New Britain, Conn. A feature of this frame is the formed sheet-metal pan, of heavy gauge, which is riveted to the side and cross-members of the frame proper, and to which the flanged motor and gear cases are bolted. This construction makes the front part of the frame practically an I-beam section laid flat, and

largely eliminates the tendency to sag or settle. It must be remembered, from the very fact that the frame material is ductile enough to have permitted of its being pressed cold without cracking, that in the very nature of things it can have no real springiness, and repeated shocks and bounces will cause it gradually to settle. This settling will occur at the weakest part of the frame, and is usually not

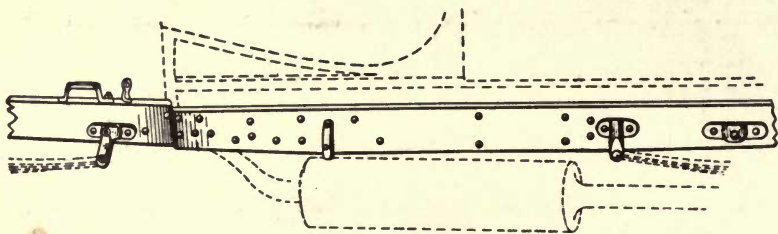

Fig. 7. Side Bar of Frame, Showing Excessive Riveting.

over one-eighth of an inch—hardly enough to be noticed with the eye; but it is enough to affect any mechanism that depends on the frame to maintain perfect alignment of parts. Troubles with bearings in engines and transmissions can often be traced to this source.

Theoretically the best material to resist this sagging tendency is steel, wood-filled. The trouble with wood filling, however, is

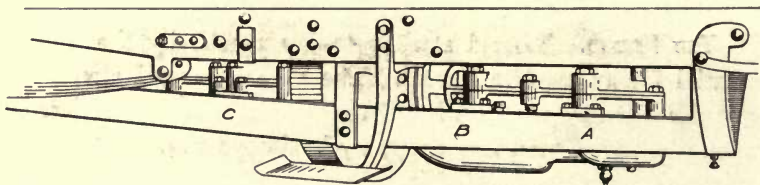

Fig. 8. Frame Weakened by Excessive Riveting in Parts Subjected to Heaviest Weight.

that hot riveting cannot be done, and cold riveting is likely to split the pressed-steel frame; so, in actual practice, the wood-filled frame has almost disappeared.

Fig. 7 shows a side bar of a typical four-cylinder car, in which altogether too many rivet-holes have been punched or drilled.

Fig. 8 shows a frame construction in which the strain tending to produce sagging has been allowed to come at points of the frame

which have already been weakened by rivet-holes. Both of these constructions are faulty, and should be avoided.

Fig. 9 shows a type of motor suspension which does away with the drop frame, and is designed for a minimum number of rivet-

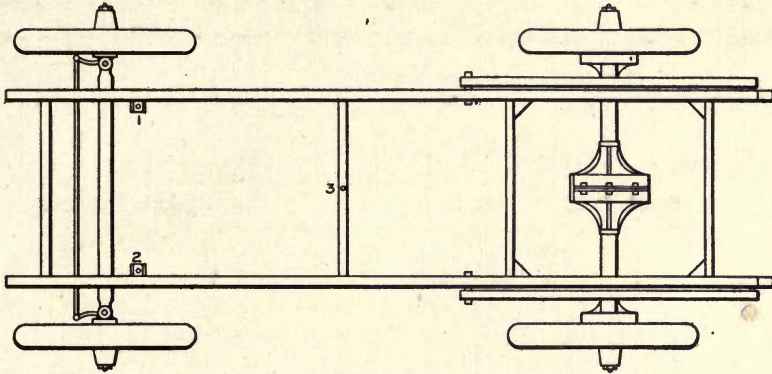

Fig. 9. Three-Point Motor Suspension.
Stevens-Duryea Company, Chicopee Falls, Mass.

holes. The motor frame is suspended at points 1, 2, and 3, points 1 and 2 being side lugs, and 3 being a cross-bar. This type of suspension is employed by the Stevens-Duryea Company of Chicopee Falls, Mass. It should be noted that the points of suspension are three. A three-point suspension of the motor is preferable to a four-point, for the reason that any lateral distortion produces an

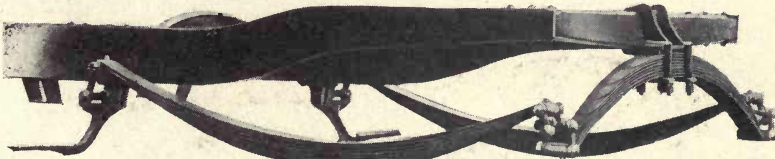

Fig. 10. Rear Spring Suspension.
Peerless Motor Car Company, Cleveland, Ohio.

undue strain at one of the four points in the latter type of suspension, while in a three-point suspension the strain is equally distributed.

Spring-Hangers. The spring-hangers are drop forgings closely fitting into the ends of the pressed-steel frame, as seen in Fig. 6. They must be of sufficient length not to unduly strain the frame, and must be hot-riveted to the frame.

Springs. Intermediate between the frame and the axles are the springs. These are attached to the spring-hangers by means of

spring links, and rest on surfaces called *spring seats* on the axles.

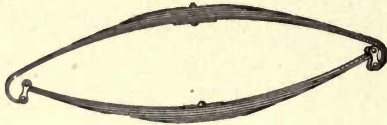

Fig. 11. Full Elliptical Spring.
Reliance Motor Car Company, Detroit,
Mich.

Fig. 10 shows the rear spring suspension employed by the Peerless Motor Car Company of Cleveland, Ohio. The springs shown are what are designated as *semi-*

elliptical springs, with eight leaves. Formerly springs were used as short as 34 inches, but the tendency is toward longer springs; 44

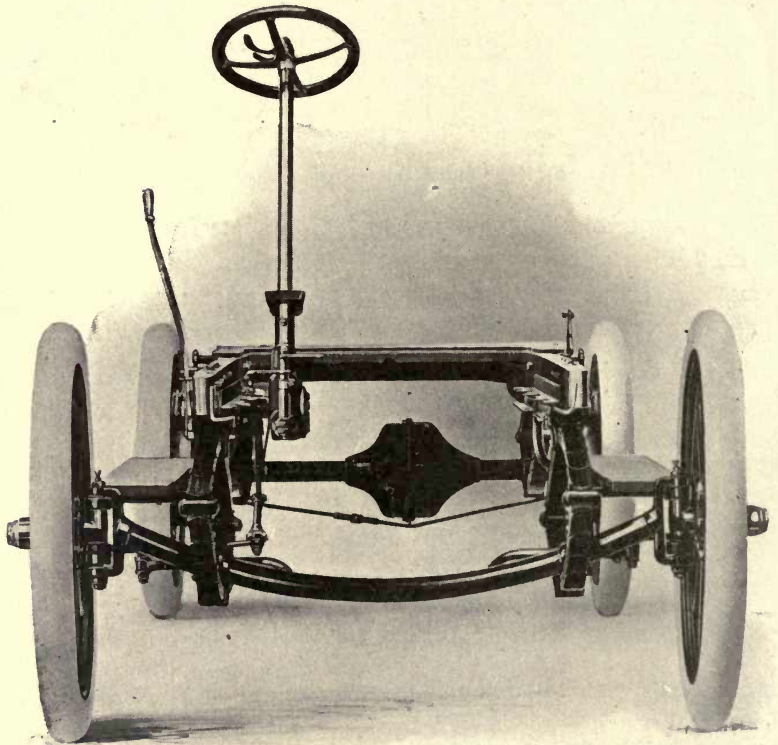

Fig. 12. Front View, Franklin Spring Suspension. Showing Tubular Front Axle.
H. H. Franklin Manufacturing Company, Syracuse, N. Y.

inches being not an uncommon length. Fig. 10 also illustrates what is called the *drop* type of frame construction, the frame drop-

ping down between the wheels so as to carry the passengers nearer the ground and thus lower the center of gravity of the loaded car.

Fig. 11 shows a *full elliptic spring*, with five leaves. This type of spring is used on the lighter types of cars, but has been largely superseded by the semi-elliptical in heavier cars.

Front Axles. Front axles have developed from the solid type with steering yoke part of the same forging, to the tubular type with drop center and with the steering yoke drop-forged and brazed onto

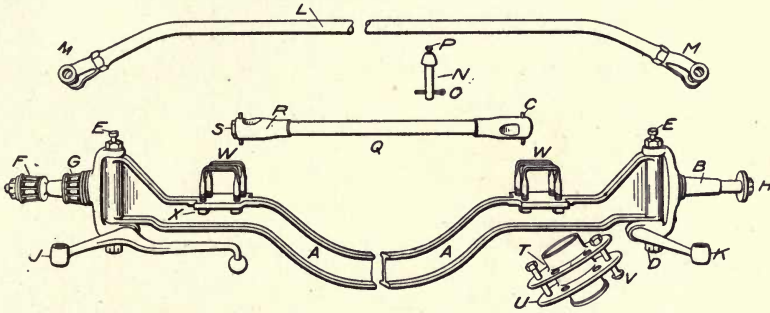

Fig. 13. I-Beam Type of Front Axle, with Parts Making Up Front-Axle System, as Used in Frayer-Miller Cars.

A—Axle; B—Knuckle; C—Pins; D—Nuts; E—Oiler; F, G—Roller Bearings (Timken); H—Nut; J, K—Steering Arms; L—Cross-Rod; M—Yokes; N—Pins; O—Cotters; P—Oiler; Q—Fore and Aft Connecting Tube; R—Ball Joint; S—Nut; T—Front Hub; U—Flange; V—Bolts; W—Spring Clips; X—Nuts.

Oscar Lear Automobile Company, Columbus, Ohio.

the main axle tube. The tubes employed are seamless, of 2 to 2½ inches diameter, with ¼-inch walls. However, the uncertainty of workmanship in connection with brazing has resulted in a tendency toward the I-beam type of front axle, in which the steering yoke is part of the same piece, as is also the spring seat.

Fig. 12 shows the tubular type of front axle as employed in the Franklin motor-car. Fig. 13 shows the I-beam type of axle, together with a list of detail parts which go to make up the assembled front axle, as used in the Frayer-Miller car.

Rear Axles. Rear axles are mostly of the *live* or *rotating* type. A few cars which use the double-chain drive employ a *non-rotating* or *dead* rear axle—that is, one on which the wheels turn, while the axle itself does not turn with the wheels. This type of axle is considerably used on commercial trucks.

For touring cars and passenger cars generally, the tendency in America has been towards the *live* axle, usually made in halves, each

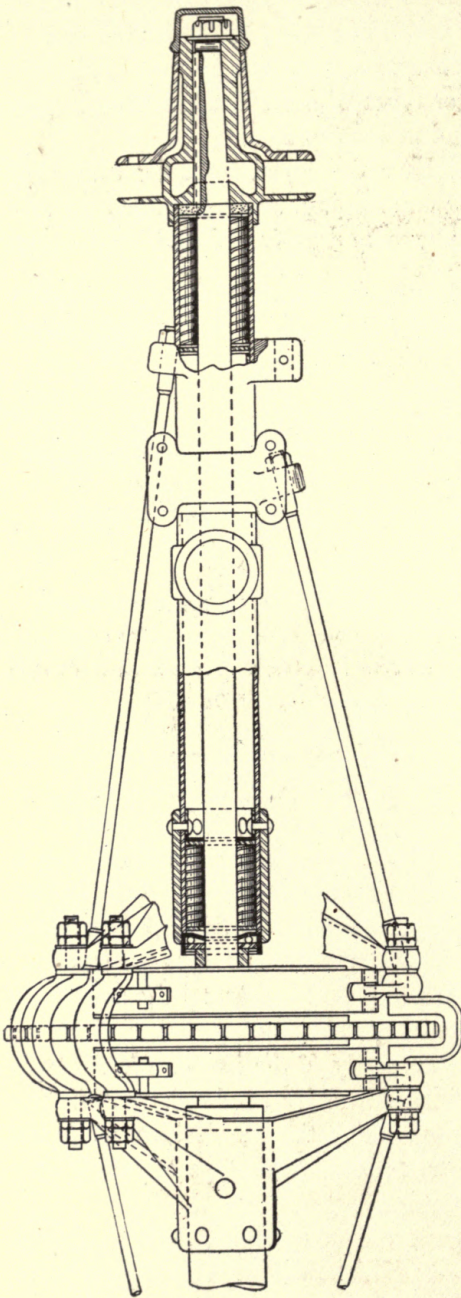

Fig. 14. Live Rear Axle, Halves Meeting at Differential. Chain-Driven, as Used in Cadillac Automobile, Detroit, Mich. Hyatt Roller Bearing Company, Harrison, N. J.

half driven from a centrally located differential gear set. The construction and operation of differential gears is more fully taken up later under the heading of "Power Transmission."

Fig. 14 shows a *chain-driven* rear axle, the axle being in two halves. The rear wheels are keyed onto each half of the live axle, which rotates in roller bearings. The illustration shows the axle used by the Cadillac Automobile Company.

Fig. 15 shows the axle construction used on Reo cars.

Fig. 16 shows a *shaft-drive* rear axle of the live type, the wheels rotating with the axle.

Fig. 17 shows what is known as the *clutch-drive* or *floating* type of live axle. In this type the rear wheels do not rotate on and with the live axle-halves, but, as seen in the cut, they rotate on the dead

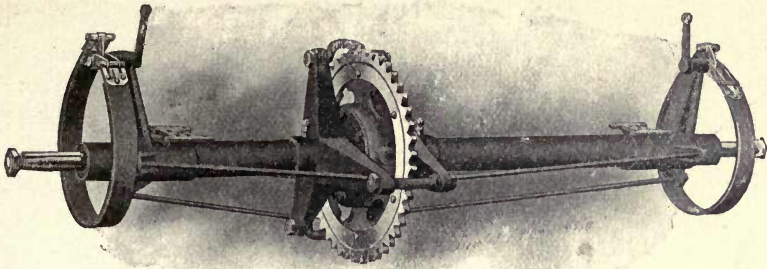

Fig. 15. Axle Construction on Reo Cars.
Reo Motor Car Company, Lansing, Mich.

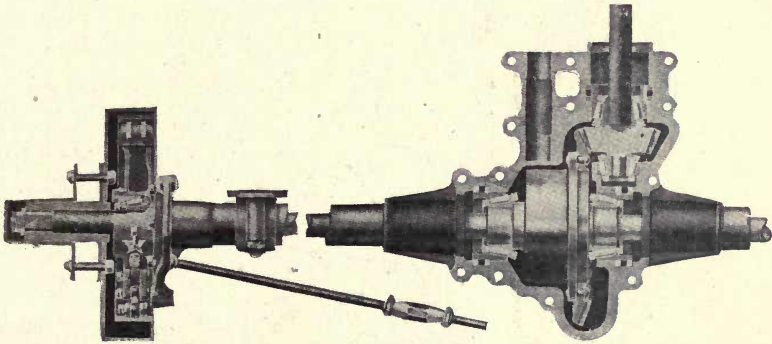

Fig. 16. Shaft-Drive Rear Axle, Rear Vertical View at Left,
Horizontal View at Right.
Timken Roller Bearing Axle Company, Canton, Ohio.

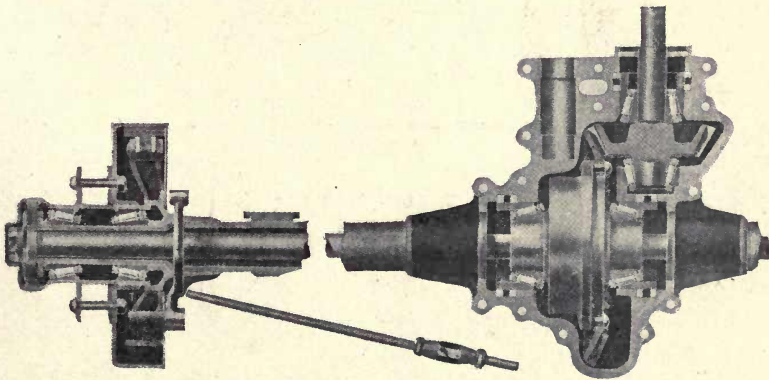

Fig. 17. Clutch-Drive or Floating Type Rear Axle, Rear Vertical View at Left,
Horizontal View at Right.
Timken Roller Bearing Axle Company, Canton, Ohio.

outer casings of the axle, without being connected to it except through the dog-clutch, which is kept in position by the hub-cap. In this type the axle tubes carry the weight of the car and of the wheels.

Rear-axle tubing should be not less than 2 inches in diameter; some cars use as large as 3 inches in diameter. The tubing should be reinforced by a strut, as shown in the cuts.

Steering Yoke, Neck, and Knuckle. The front axle terminates

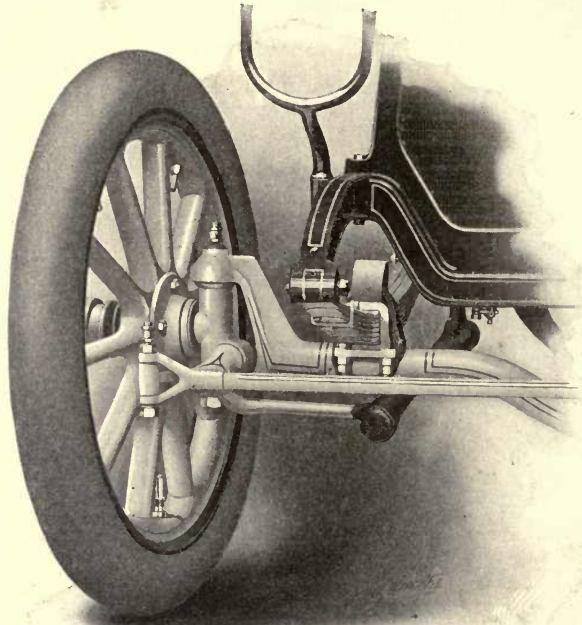

Fig. 18. Steering Yoke, Neck, and Knuckle.
Packard Motor Car Company, Detroit, Mich.

at either end in the *steering yoke*. In the tubular type of front axle, the steering yokes are usually brazed into the axle tube. The I-beam type of front axle usually has the yoke part of the I-beam piece, thus making the axle and steering yoke all in one piece, securing a better construction.

Fig. 18 shows the tubular type of axle, together with steering yoke, neck, and knuckle, as employed by the Packard Motor Car Company, of Detroit, Mich. The yoke, it will be seen, carries the

vertical steering spindle or *neck*. The latter, in turn, supports the wheel, and is also attached to the *steering knuckle*.

Fig. 19 shows a detail of steering knuckle as used in the Rambler car built by Thos. B. Jeffery & Company, Kenosha, Wis. The load

is carried on the thrust-bearing shown in section under the upper arm of the steering yoke. This bearing comprises two hardened tool-steel plates and a row of thirteen $\frac{3}{8}$ -inch steel balls. The center pin is tapered from $1\frac{1}{8}$ inches at the top to $\frac{7}{8}$ inch at the bottom. At each end is a nut bearing against the yoke, whereby the position of the taper

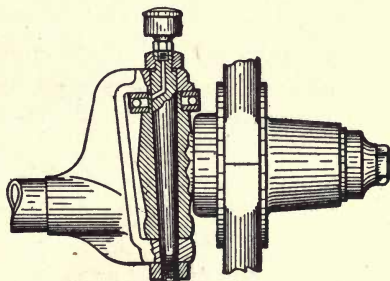

Fig. 19. Detail of Steering Knuckle,
Rambler Car.
Thomas B. Jeffery & Co., Kenosha, Wis.

pin within this bearing in the knuckle may be adjusted. To adjust it, the nut at the upper end must be loosened, and the one at the lower end tightened. This will draw the taper downward into its seat in the knuckle. If too tight, release the lower nut and screw down the upper one. When properly adjusted, tighten both nuts.

The ball thrust-bearing is usually packed in hard grease, and will require very little attention. The center pin is provided with an

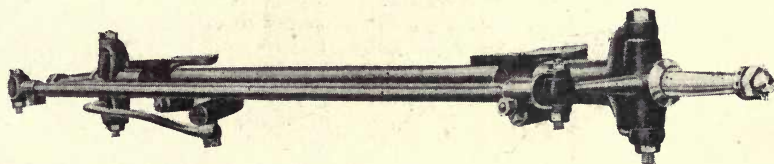

Fig. 20. Steering Mechanism of the Cartercar.
Motor Car Company, Detroit, Mich.

oil-cup which feeds through a vent as indicated, into the bearing of the pin.

Steering Connections. The two steering knuckles are connected by a rod known at the *transverse rod* or *cross-rod*, so that they will move in unison. This rod is shown in Fig. 20, as used in the Cartercar, built by the Motor Car Company, Detroit, Mich.

The vertical steering spindle or neck, in addition to carrying the wheel bearing, in the case of the right-hand spindle is usually made so

as to form also in one piece the steering arm. This construction is shown in Fig. 21, as used by the Timken Roller Bearing Axle Company, Canton, Ohio. It will be noticed that the steering arm terminates in a round ball. This ball is part of a ball-and-socket joint

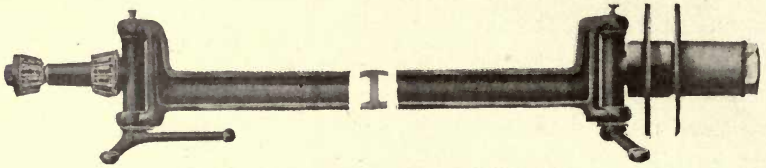

Fig. 21. Steering Arm, Showing Ball Joint.
Timken Roller Bearing Axle Company, Canton, Ohio.

connecting the steering arm, through a reach-rod, to the sector shaft of the steering column.

Fig. 22 shows the reach-rod as used in the Oldsmobile, made by the Olds Motor Works, Lansing, Mich. The socket part of the ball-and-socket joint is usually composed of two hollowed-out bronze blocks adjustable for wear.

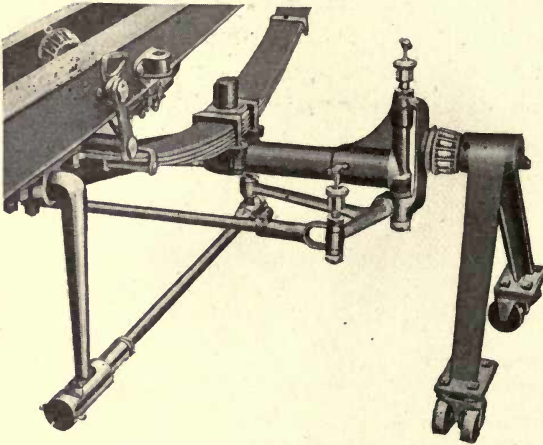

Fig. 22. Steering Connections of Oldsmobile.
Olds Motor Works, Lansing, Mich.

Steering Gear.

Cars are almost universally steered by means of a large-diameter hand-wheel on the top of a considerably inclined tubular steering post or column. The steering wheel is usually made of a solid three-arm brass ring, covered with black walnut

or cherry and given a natural wood finish. The steering column is made of heavy steel tubing with brass tube outside, the outer casing serving for a standard or support. The innermost tube is the one usually used for steering purposes. Concentric with the steering tube, and surrounding it, there are frequently placed other tubes

which serve other purposes—in connection with spark and throttle control.

The steering wheel's motion is transmitted through the innermost tube, to a screw or worm, which in turn meshes with a nut or gear or sector of a gear, operating a bell-crank connected with the steering arm.

The screw and split or adjustable nut type of construction is claimed to be less liable to have back-lash than the worm-and-gear type, as in the former all back-lash due to wear may be readily taken up.

Fig. 23 shows a steering column of the screw and nut type as used by the Knox Automobile Company, Springfield, Mass. The screw is integral with the column, and is cut from the solid bar. The nut is exceptionally long, and is formed of hard babbitt, finished to exactly fit the quintuple thread; and has a formed space on one side fitting a corresponding block upon the cap, thus preventing the nut from turning. The bell-crank in this part is of nickel-steel. Fig. 24 shows a detail of the nut and bell-crank in this same column.

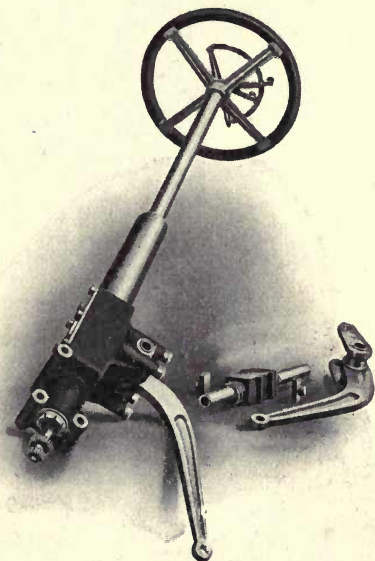

Fig. 23. Steering Column of Screw and Nut Type.
Knox Automobile Company, Springfield, Mass.

The steering mechanism of an automobile is subjected to more severe stresses and heavy vibratory strains than any other part, and a break in the steering gear is almost certain to result in a dangerous accident. Hence the need for most liberal dimensions and superfine quality of material, and for extreme care in construction of all parts connected with the steering system.

Fig. 25 shows the worm-and-gear type of steering gear as used by the Peerless Motor Car Company, of Cleveland, Ohio. This type is found used about as frequently as the screw and nut type; and if

the gears are perfectly cut, truly adjusted, and made of best material, there should be no perceptible wear. In the gearing system shown in the illustration, the worm is located at the base of the steering column proper. When the hand-wheel is turned, this turns a gear.

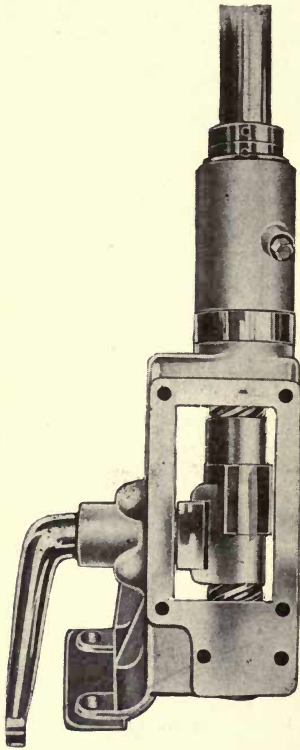

Fig. 24. Detail of Nut and Bell-Crank in Screw and Nut Type of Steering Gear.
Knox Automobile Company,
Springfield, Mass.

A shaft is forged with this gear, to which is attached an arm operating the connecting-rod to the steering knuckles. Around the shaft, where it protrudes through the gear casing, is an eccentric bushing graduated by thirty-seconds of an inch, which may be moved to take up any lost motion in the steering wheel. Moving this bushing so that the widest part is away from the steering column, forces the gear into closer mesh with the worm. Moving this bushing a quarter of an inch at the most, should be enough to take up any wear. Should any of the teeth become worn, disconnect the arm from gear to connecting-rod, and five complete turns of the steering hand-wheel will give a new set of teeth on the gear. Thrust-bearings with $\frac{3}{8}$ -inch balls are placed above and below the gear on the steering column, and are self-seating; and the worm is adjusted for end play by screwing down an adjusting nut at top of casing.

The more usual form is to use simply a sector of a gear, instead of a whole gear. This type of construction is shown in Fig. 26, as used by the Corbin Motor Vehicle Corporation, of New Britain, Conn. The form shown is a worm and sector cut by the Hindley patented process. By this process, every tooth in the worm is in contact with, and for the full width of, the sector face. The steering case is of Parsons manganese bronze, and all minor parts of the steering system are made of high-class steel forgings.

THE POWER PLANT

The power plant of an automobile includes the prime mover and all the accessories necessary to start it and keep it in continuous motion. In the case of the electrically driven automobile, the power plant includes the batteries, rheostat, motor, and other details which will be described under the heading of Electrically Driven Cars. In the case of steam-propelled automobiles, the power plant includes the boiler, engine, heating outfit, and accessories as de-

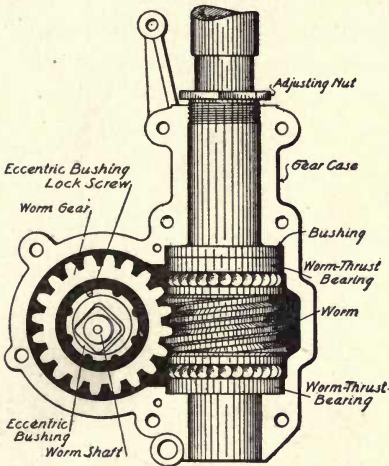

Fig. 25. Worm-and-Gear Type of Steering Gear.
Peerless Motor Car Company, Cleveland, Ohio.

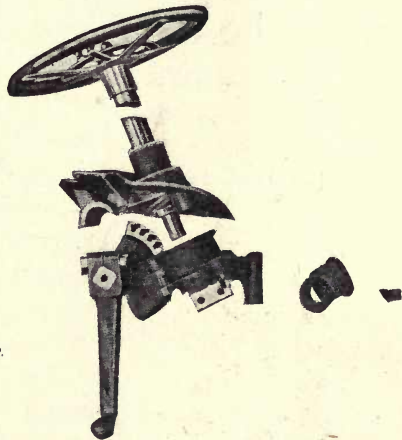

Fig. 26. Worm and Sector Type of Steering Gear.
Corbin Motor Vehicle Corporation, New Britain, Conn.

scribed under the heading of Steam-Driven Cars. In the case of the gasoline-driven car, the power plant naturally groups itself as follows:

1. The engine proper, consisting of the reciprocating parts, the rotating parts, the cylinders, the crank-case, and the valves.
2. The fuel system, consisting of the gasoline tank and its connections through the carbureter to and from the engine.
3. The ignition system, consisting of the batteries, the spark-coils, the magneto or dynamo, the commutator, and the spark-plugs.
4. The cooling system, consisting of the fan, and, in water-cooled engines, also of the water tank, the water pump or siphon, the radiator, and interconnecting parts.
5. The lubricating system of the motor.

The Gas-Engine Cycle. The gas-engine cycle consists of four distinct steps—namely:

1. Admission of the charge of explosive fuel.
2. The compression of this charge.
3. The ignition or explosion of this charge.
4. Exhaust or expulsion of the burnt charge.

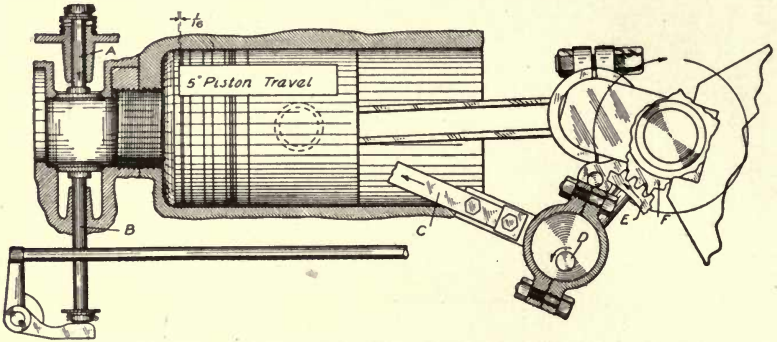

Fig. 27. Beginning of Suction or First Stroke in a Four-Cycle Engine.
Cadillac Motor Car Company, Detroit, Mich.

If the complete process as above requires four strokes of the piston-rod in any one cylinder, the engine is designated as a *four-cycle engine*, although a more exact designation would be to call it a *four-stroke*

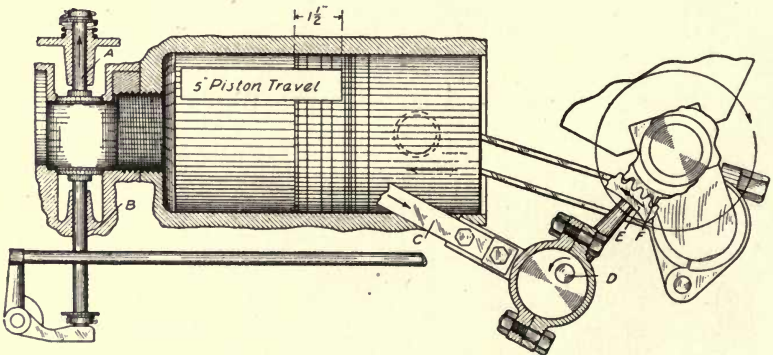

Fig. 28. Beginning of Second or Compression Stroke in a Four-Cycle Engine.
Cadillac Motor Car Company, Detroit, Mich.

cycle. If the complete process is accomplished in two strokes of the piston, the engine is designated as a *two-cycle engine*.

Figs. 27, 28, 29, and 30 show the positions of piston and valves during these four steps, as they take place in the Cadillac single-cylinder four-cycle engine.

Fig. 27 shows the beginning of the first or suction stroke of the cycle. At $\frac{1}{16}$ inch past the dead center or end of the stroke, the inlet valve *A* commences to open, which allows the vapor supplied by the carburetor to be drawn into the cylinder, the motor running as indicated by the arrows. During this stroke the exhaust valve *B* is closed. The inlet valve *A* is opened by the eccentric rod *C*, its movement being controlled by the eccentric on the secondary shaft *D*. This shaft is driven at one-half the speed of the motor by the two-to-one gear *E* and pinion *F*.

Fig. 28 shows the beginning of the second or compression stroke at the closing point of the inlet valve, both valves being closed during

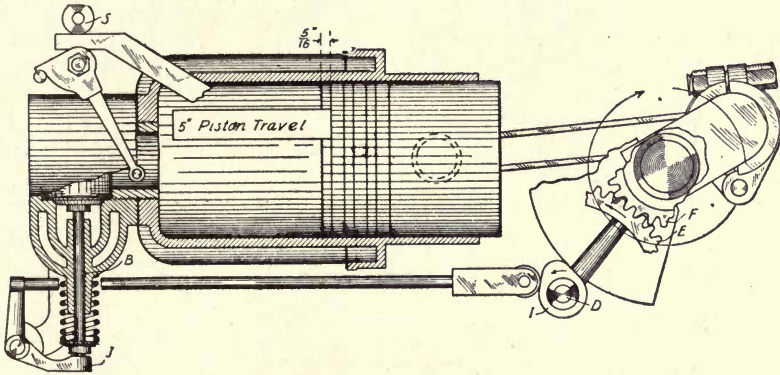

Fig. 29. End of Working or Third Stroke in a Four-Cycle Engine.
Cadillac Motor Car Company, Detroit, Mich.

this stroke. The piston, traveling as indicated by the arrow, compresses the charge to a pressure of about 60 pounds, and the compressed charge is ignited at or before the end of this stroke by a spark taking place in the *spark-plug* (the action of which will be explained in the discussion of Ignition Systems), the force of the explosion driving the piston forward to the position shown in Fig. 29.

During these two strokes—namely, the compression and working strokes—both valves, if correctly timed, should be completely closed.

Fig. 29 illustrates the end of the working stroke or third stroke of the cycle, where the exhaust valve commences to open $\frac{5}{16}$ inch from the end of the stroke, or slightly previous to dead center.

During the fourth or exhaust stroke, the gases are expelled from the cylinder through the valve *B*. The exhaust valve *B* is operated by the cam *I*, which pushes the exhaust rocker arm *J* and lifts the exhaust valve *B*.

Fig. 30 shows the position when the exhaust valve *B* has just closed $\frac{1}{32}$ inch of the stroke past dead center. The inlet valve *A* will open $\frac{1}{32}$ inch later, admitting new vapor, as in Fig. 27.

Two-Cycle Engines. In two-cycle engines the crank-case is used to admit the charge while the piston is on the upward stroke.

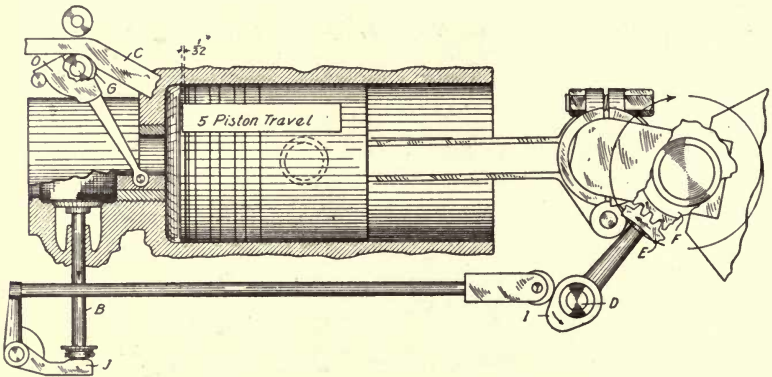

Fig. 30. End of Fourth or Exhaust Stroke in a Four-Cycle Engine. Cadillac Motor Car Company, Detroit, Mich.

On the working or downward stroke of the piston, the vapor in the crank-case is forced through a by-pass, by the descending piston, this by-pass admitting it into the upper part of the cylinder, where it is compressed into small volume and ignited at the proper time.

In the two-cycle engine the process of exhausting the burnt gases and admitting the new charge are both performed during a single downward stroke, the exhaust port being uncovered first by the piston and allowing the greater part of the burnt gases to escape before the inlet port is opened. Hence, in the two-cycle engine, an impulse is received with each revolution of the fly-wheel and main shaft; in the four-cycle engine an impulse is received every fourth stroke or every other revolution of the fly-wheel and crank-shaft.

The two-cycle engine offers strong talking points, since all mechanically operated valves are replaced by mere port-holes, which

results in greater mechanical efficiency. Moreover, the more frequent working impulses should result in a constant torque and much smoother running. Two-cycle engines have been in use quite generally on motor-boats. The engines of the two-cycle type built for marine work have always shown considerable irregularity in running; and it has been the general impression that the operations of charging, compressing, firing, and exhausting cannot be properly accomplished during one revolution. However, it may be that, just as the air-cooled engine is gaining greatly in favor, though several years ago not considered equal to the water-cooled type, so a similar change in favor of the two-cycle engine may be brought about as this type of engine is perfected. There are several cars now on the market, notable among them being the Elmore and the Jewel, which are showing up very favorably with two-cycle engines.

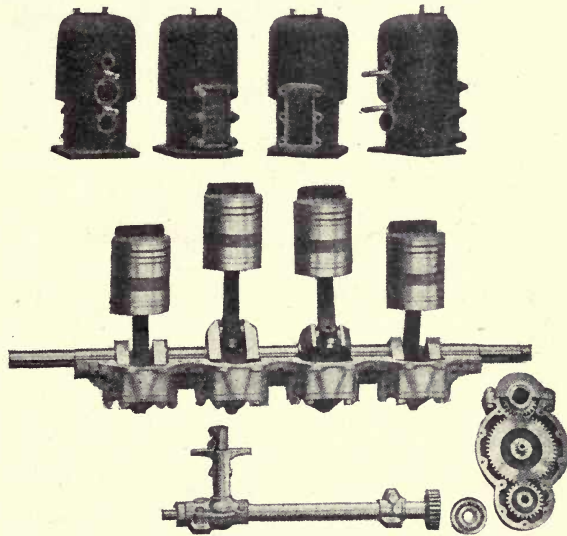

Fig. 31. Working Parts of Elmore 4-Cylinder 2-Cycle Motor, Showing Small Number of Parts. Elmore Manufacturing Company, Clyde, Ohio.

Fig. 31 shows the working parts of the Elmore valveless two-cycle engine. Each cylinder on a four-cycle engine has more parts than all of the cylinders here shown.

Working Parts of Engine. It is essential that every automobile operator should be familiar with the names of the working parts of the engine.

As the single-cylinder engines such as used in the Reo, the Oldsmobile, the Cadillac, and other well-known runabouts, are easier to list in detail than multiple-cylinder engines, a typical example of a single-cylinder engine, showing parts in detail, is given in Fig. 32.



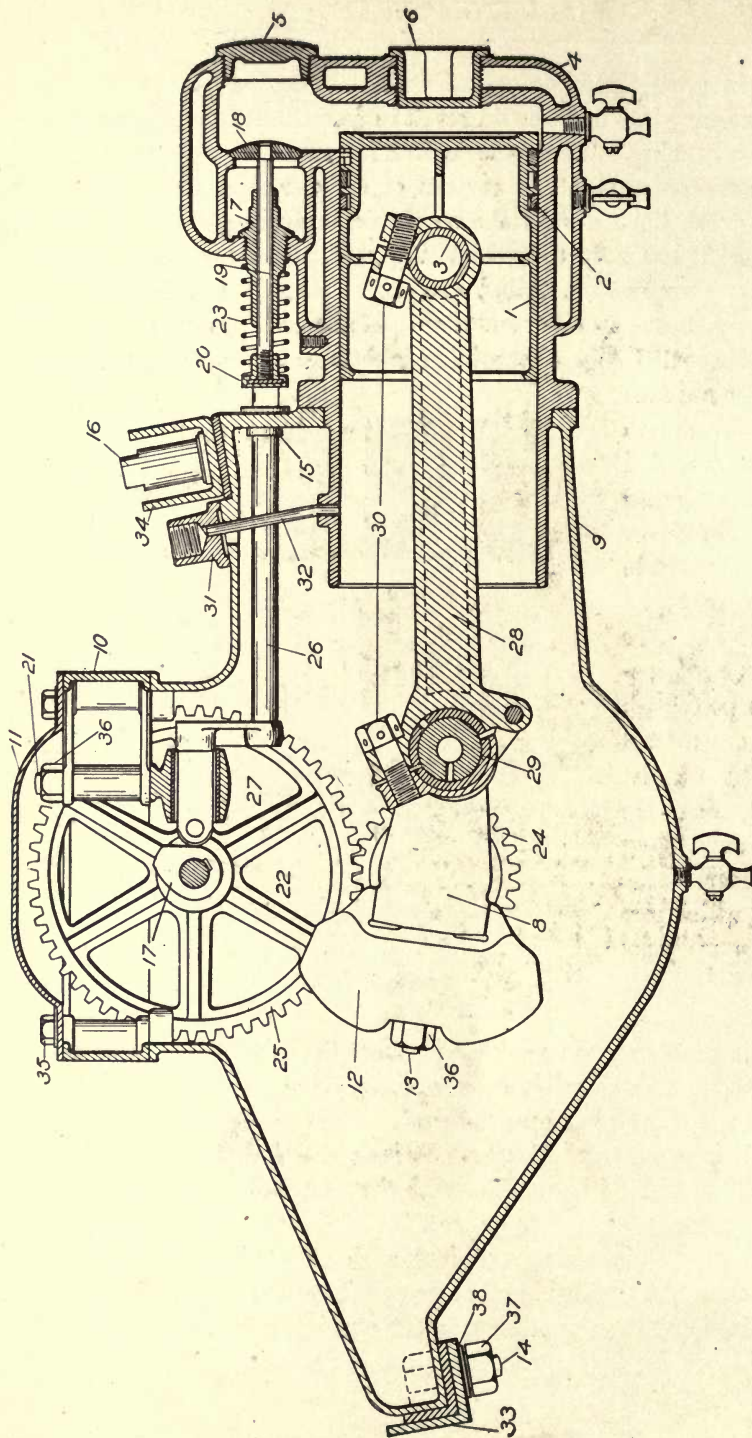

Fig. 32. Diagram Showing Detailed Parts of Single-Cylinder Engine as Used in the Reo Car. Reo Motor Car Company, Lansing, Mich.
 1—Piston; 2—Piston-Ring; 3—Piston Pin; 4—Cylinder; 5—Valve-Cover; 6—Water-Jacket Plug; 7—Valve-Stem Guide; 8—Crank-Case; 9—Crank-Shaft; 10—Crank-Case Valve Box; 11—Crank-Case Valve Box Cover; 12—Counterweights; 13—Counterweights Stud; 14—Stud Crank-Case to Frame; 15—Valve-Rod Bushing; 16—Nut for Crank-Case Stud; 17—Exhaust Cam; 18—Valve; 19—Valve Stem; 20—Valve-Stem Head; 21—Valve-Rod Bearing; 22—Valve Roller; 23—Exhaust Valve Spring; 24—Small Cam Gear; 25—Large Cam Gear; 26—Valve-Rod; 27—Valve-Rod Head; 28—Connecting Rod; 29—Connecting-Rod Cap; 30—Connecting-Rod Bolt; 31—Oil-Cup Support; 32—Cylinder Oil Tube; 33—Rear Engine Support; 34—Front Engine Support; 35—Hexagon Nut, $\frac{1}{2}$ -Inch; 36—Hexagon Nut, $\frac{1}{4}$ -Inch; 37—Hexagon Nut, $\frac{1}{8}$ -Inch; 38—Spring Washer, $\frac{1}{8}$ -Inch.

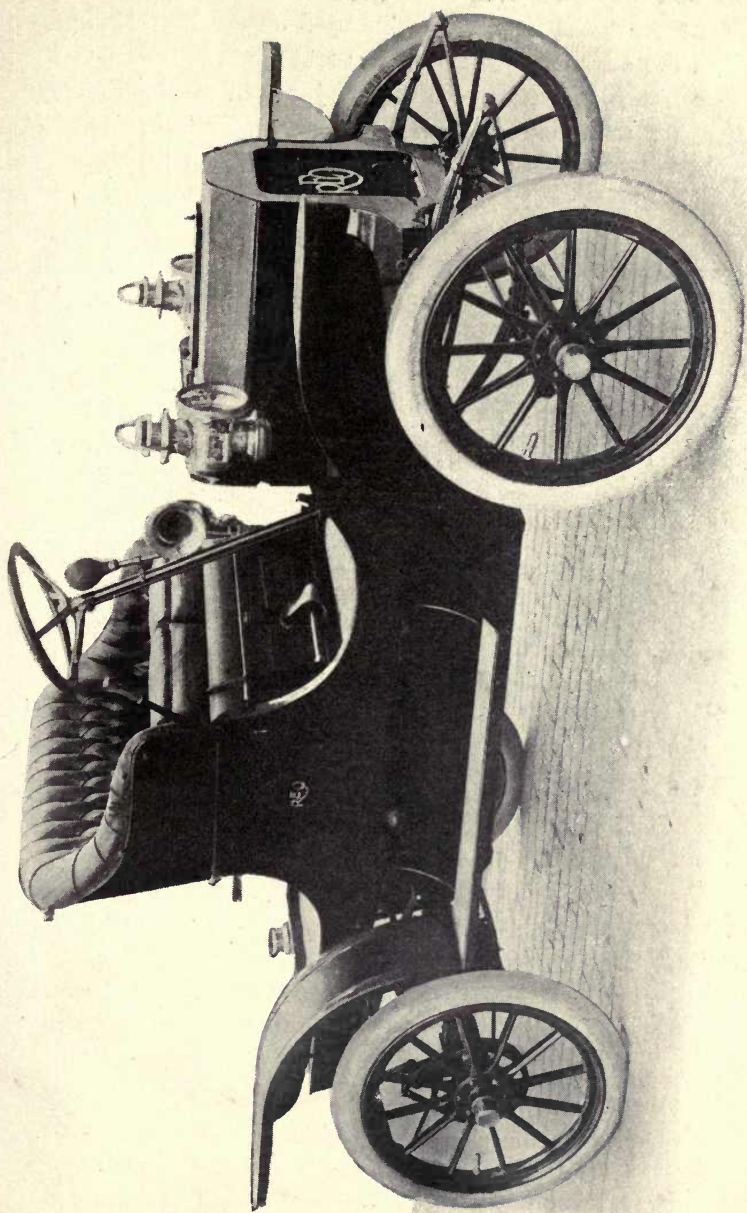

Fig. 32A. Reo Single-Cylinder Runabout. Reo Motor Car Company, Lansing, Mich.

Single- and Multiple-Cylinder Engines. The *single-cylinder* engine is of necessity the type of engine used on the lowest-priced cars. It has the advantage of simplicity; and when it comes to a choice between a high-grade, relatively high-priced single-cylinder engine car and a multiple-cylinder car with a cheaply built engine, there can be but one choice, and that in favor of the high-grade single-cylinder engine, as, in the other alternative of cheaper cylinders and more of them, one buys only more trouble.

The single-cylinder engine, having only one working impulse

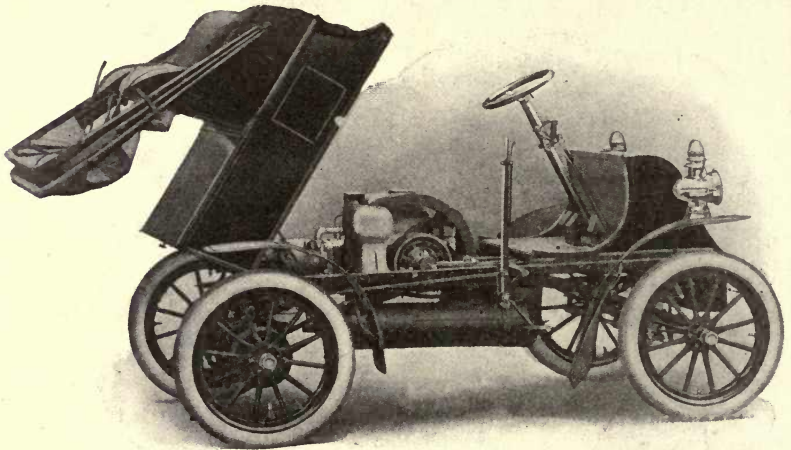

Fig. 33. One-Cylinder Engine as Used in Hewitt Motor-Car.
Hewitt Motor Company, New York, N. Y.

for every two revolutions, requires a fly-wheel of heavier weight and larger diameter than is used in the multiple-cylinder engines.

Fig. 33 shows a well-proportioned one-cylinder engine, as used by the Hewitt Motor Company, New York City.

In the single-cylinder construction, even with the very best engine, the vibration is decidedly noticeable when the engine is slowed down under load, as when climbing a hill.

The *two-cylinder opposed type* of construction gives a very good balancing of reciprocating parts. Fig. 34 shows this type of engine as used in the Reo touring car. The motor runs in the same direction as the car, and causes no sidewise vibration, which adds materially to the life of the car. The original two-cylinder opposed cars placed the engine under the body, many of them having the

engine crosswise of the car, thus causing undue vibration, besides having the engine in an inaccessible position. Most modern cars with a capacity of twelve to twenty horse-power, place the two-cylinder engine under the hood, but keep the engine in a horizontal position.

For powers over twenty horse-power, the four-cylinder engine is in almost universal use. The construction of the engine in Fig. 35 is what is known as the *separately cast cylinder type* of engine.

Another type of four-cylinder construction, and one quite generally used, is the *cast-in-pair* type. The latter construction takes up less room, giving a more compact motor, making possible a shorter hood, and also giving less weight. On the other hand, by casting each cylinder separately, it is possible to have a bearing between each crank, thus giving greater bearing surface, lessening the strains on the crank-shaft, and increasing the life of the bearings. Moreover, should one cylinder be burnt out or cracked, in the separately cast cylinder type this would mean the loss of but one cylinder, while in the cast-in-pair type it would mean the loss of the pair of cylinders. On the whole, the greater advantage lies with the separately cast construction.

On the other hand, by casting each cylinder separately, it is possible to have a bearing between each crank, thus giving greater bearing surface, lessening the strains on the crank-shaft, and increasing the life of the bearings. Moreover, should one cylinder be burnt out or cracked, in the separately cast cylinder type this would mean the loss of but one cylinder, while in the cast-in-pair type it would mean the loss of the pair of cylinders. On the whole, the greater advantage lies with the separately cast construction.

Principal Engine Parts; Material and Workmanship. The proper material for water-cooled gas-engine cylinders is a fine-grained gray iron mixture. Several makers of high-grade engines anneal the cylinders after they are bored, and grind them to gauge after annealing. This method of machining has been found to reduce to a minimum the liability to distortion of the cylinder under the temperature strains to which it is subjected.

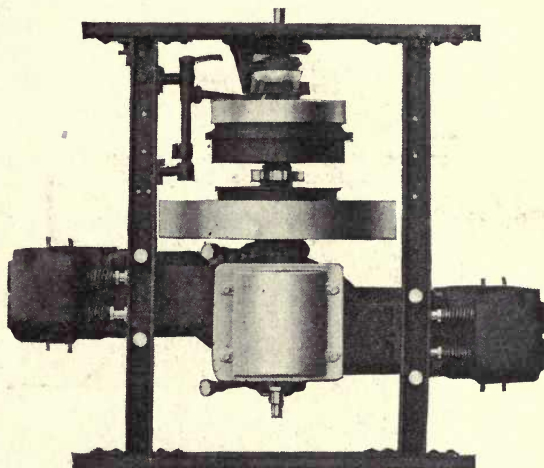

Fig. 34. Two-Cylinder Opposed Engine of Reo Car. Reo Motor Car Company, Lansing, Mich.

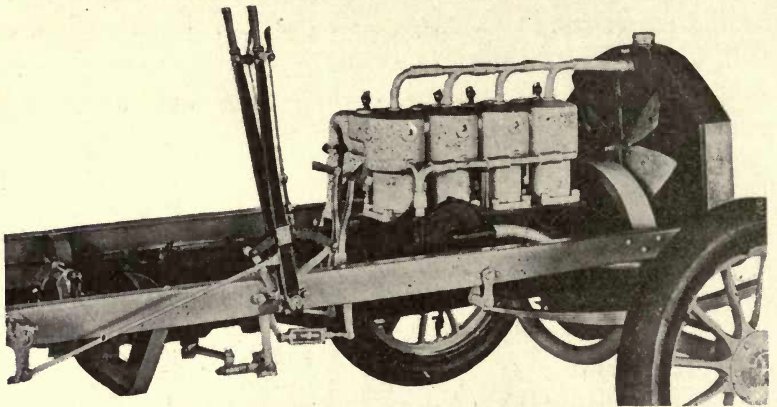

Fig. 35. Four-Cylinder Vertical Engine with Fly-Wheel in Front.
Stevens-Duryea Company, Chicopee Falls, Mass.

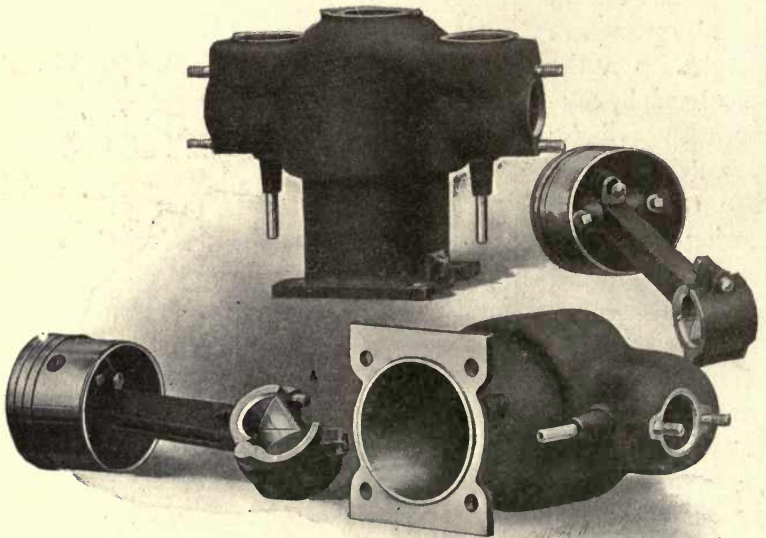

Fig. 36. Cylinders, Pistons, and Connecting Rods in Separately Cast Cylinder
Type of Construction.
Maxwell-Briscoe Motor Company, Tarrytown, N. Y.

Fig. 36 shows the cylinders, pistons, and connecting rods of the Maxwell-Briscoe motor, Tarrytown, N. Y. This illustrates the separately cast cylinder type of construction.

Fig. 37 shows cylinders, pistons, connecting rods, crank-shaft, and fly-wheel of the Packard motor, Detroit, Mich. This illustrates the cast-in-pair type of cylinder construction.

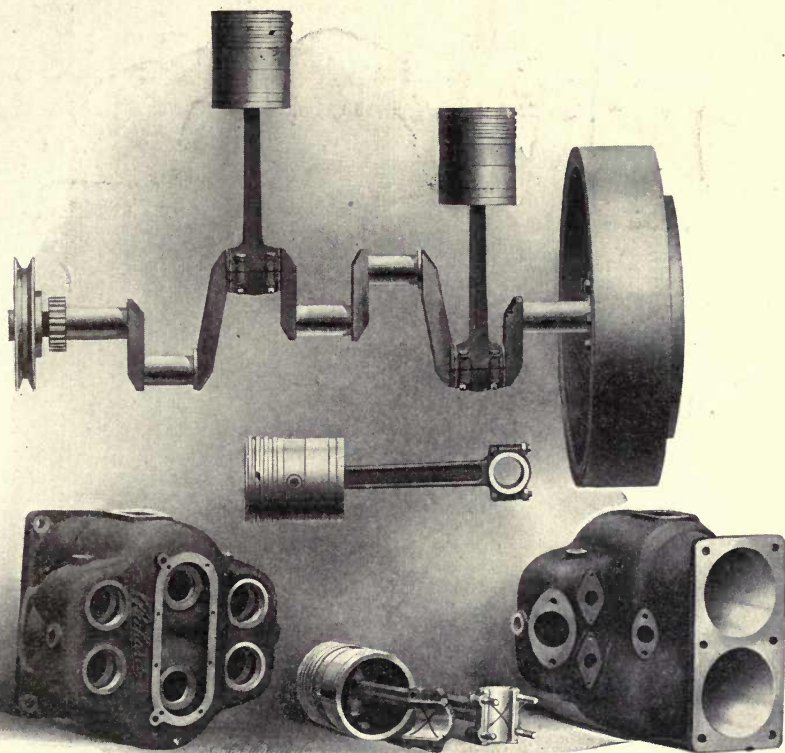

Fig. 37. Disassembled Motor of Packard Car, Showing Cylinders, Pistons, Connecting Rods, Crank-Shaft, and Fly-Wheel. Cast-in-Pair Type of Cylinder Construction. Packard Motor Car Company, Detroit, Mich.

and fly-wheel of the Packard motor-car, Detroit, Mich. This illustrates the cast-in-pair type of cylinder construction.

In each of these illustrations the projecting spaces at the sides of the main cylinder are the valve chambers.

The *crank-shaft* in the best engines is machined from a solid forged slab of high-carbon steel or nickel-steel. By *high-carbon* steel, in the case of a crank-shaft, is meant a steel having a percentage of from .28 to .30 of carbon. Some of the nickel-steels now used in

crank-shaft construction have a tensile strength as high as 225,000 pounds to the square inch, and an elastic limit of 135,000 pounds.

Fig. 38 shows the steps in the cold-machining of a crank-shaft as used in the Columbia car built by the Electric Vehicle Company,

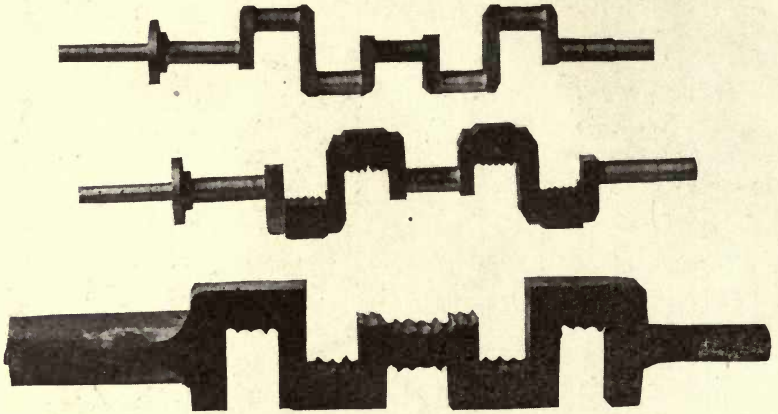

Fig. 38. Steps in Cold-Machining of Crank-Shaft from Solid Slab, for Columbia Car. Electric Vehicle Company, Hartford, Conn.

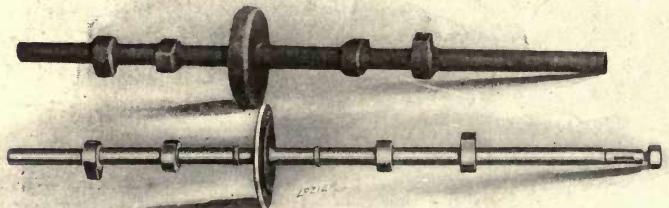
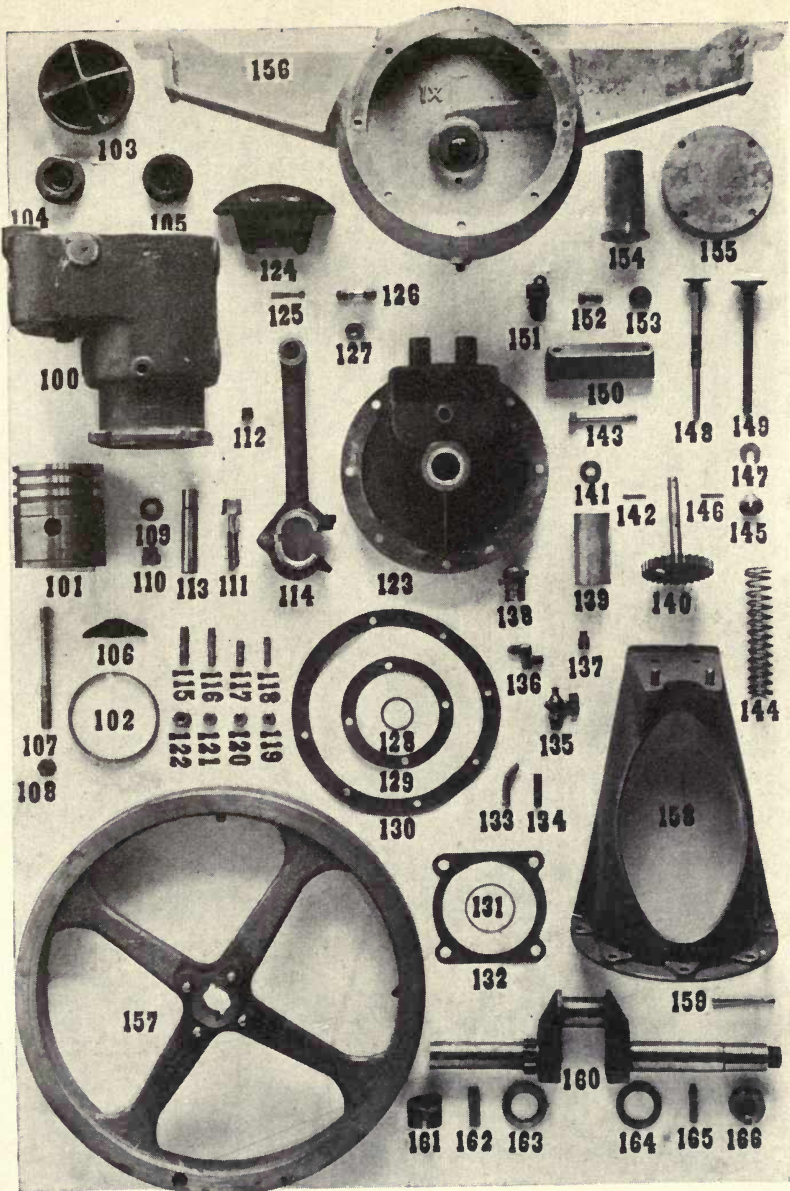

Fig. 39. Cam-Shaft, Crucible Steel Forging and Finished Product. Lozier Motor Company, Plattsburg, N. Y.

Hartford, Conn. The next best construction is one in which the crank-shaft is hammered and bent into shape before machining; while the cheaper engines use a drop-forged shaft, which is not as likely to withstand severe strains as either of the two previously named types.



DISASSEMBLED PARTS OF BRUSH RUNABOUT MOTOR, MODEL B.

Brush Runabout Company, Detroit, Mich.

100—Cylinder; 101—Piston; 102—Piston Ring; 103—Cylinder Head; 104—Valve-Cap (Spark-Plug); 105—Valve-Cap (Relief); 106-7-8—Elbow Binder, Stud, Nut; 109-10-11—Connecting-Rod Washer, Nut, Screw; 112—Piston Pin Plug; 113—Piston Pin; 114—Connecting Rod; 115—Cylinder Stud; 116-7—Side-Plate Studs (Long, Short); 118-9—Hand-Hole Cover Stud, Nut; 120-1—Nuts for Side-Plate Stud (Short, Long); 122—Cylinder Stud Nut; 123—Side Plate; 124—Counterbalance; 125—Counterbalance Stud Cotter; 126—Counterbalance Stud; 127—Counterbalance Stud Nut; 128—Inlet Elbow Gasket (Carbureter); 129—Hand-Hole Cover Gasket; 130—Side-Plate Gasket; 131—Valve-Cap Gasket; 132—Cylinder Gasket; 133—Connecting-Rod Oil Tube; 134—Base or Crank-Case Oil Tube; 135—Cylinder Drain-Cock; 136—Oil Check-Valve on Crank-Case; 137—Drain Plug (Crank-Case); 138—Valve Cam; 139—Side Bearing Bushing; 140—Cam Gear and Shaft; 141—Cam Gear Washer; 142—Valve-Cam Pins; 143—Side-Plate Cover Screw; 144—Valve Spring; 145—Valve-Stem Collar; 146—Commutator Cam Pin; 147—Valve-Spring Washer; 148—Valve Pusher; 149—Valve and Stem; 150—Side-Plate Cover; 151—Cam Roller Bracket; 152—Cam Roller Bracket Screw; 153—Cam Roller; 154—Base Bearing Bushing; 155—Hand-Hole Cover; 156—Base of Crank-Case; 157—Fly-Wheel; 158—Front Base Arm; 159—Starting Ratchet Cotter; 160—Crank-Shaft; 161—Starting Ratchet; 162—Starting Ratchet Key; 163-4—Crank-Shaft Washers (Narrow, Wide); 165-6—Fly-Wheel Key, Nut.

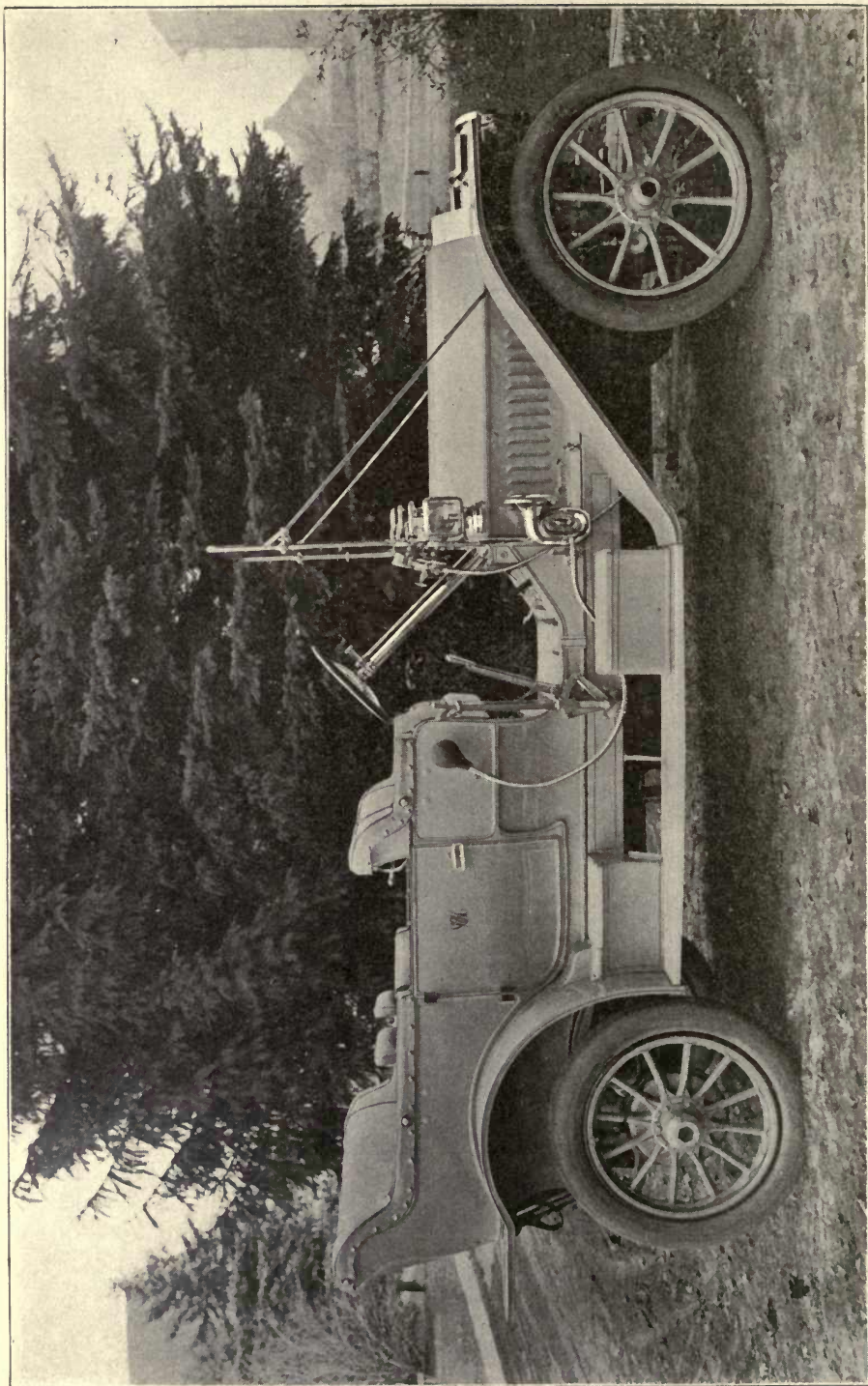

OLDSMOBILE TOURING CAR, MODEL Z.
Olds Motor Works, Lansing, Mich.

The modern tendency in high-grade engines is to observe almost equal care in the making of the *cams* and *cam-shafts* as is observed in the crank-shaft.

Fig. 39 shows a rough forging of crucible steel for the combined *cams* and *cam-shaft* as used by the Lozier Motor Company, Plattsburg, N. Y., together with the finished *cam-shaft*. The *cam* faces are hardened and ground to shape. Especial attention is also given to the bearings of the *cam-shafts*, some makers using annular ball bearings for this purpose.

The *crank-case* of most modern automobile engines is constructed of aluminum, partitioned into compartments in order to prevent an excess accumulation of oil at one end of the case in ascending or

descending a steep grade. A great many engines use the *crank-case* as the motor support, relying on aluminum arms to carry the weight of the cylinders, *crank-shaft*, and *fly-wheel*. The low tensile strength of aluminum has been an objection to this type of construction, as the arms are liable to breakage. Hence some makers have adopted a light engine base made of stronger material, such as pressed steel, to which the aluminum *crank-case* proper is bolted. Fig. 40 shows an engine base and *crank-case* of this type of construction, as formerly used by the Premier Motor Manufacturing Company, Indianapolis, Ind.

The foregoing illustrations will serve to show typical examples

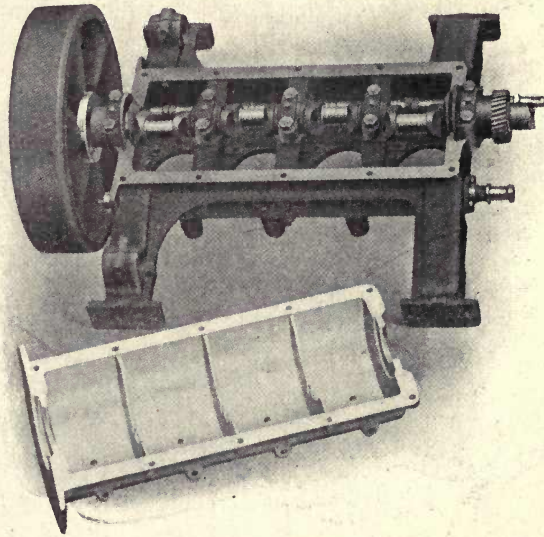

Fig. 40. Engine Base, Showing Support Piece Separate from Crank-Case, as Formerly Used by Premier Motor Manufacturing Company, Indianapolis, Ind. Case and Support are Now Made Integral.

of the main parts of the engine proper. The diagrams shown in Figs. 41 and 42 will serve to show more fully the relative location and operation of these parts—particularly the valve action.

Referring to Fig. 41, which is an end view of the Rambler engine made by Thos. B. Jeffery & Company, Kenosha, Wis., at the lower

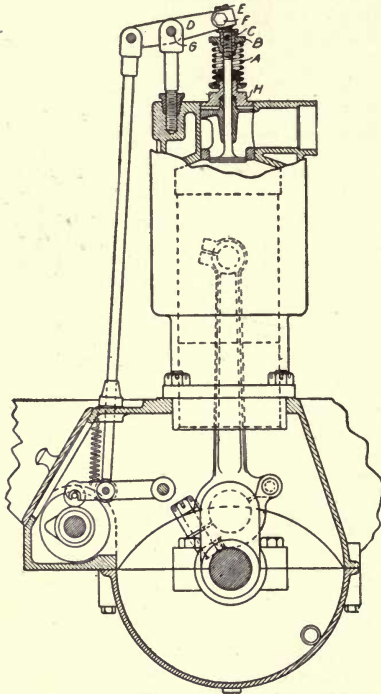

Fig. 41. End View of Rambler Engine.
A—Valve-Spring; B—Spring Adjusting Nut; C—Lock Nut; D—Rocker Arm; E—Screw for Taking Up Play in Rocker Arm; F—Cap Screw for Locking E; G—Pivot Pin for Rocker Arm; H—Hexagon Nut for Screwing Valve Cage into Position.

left-hand side will be noticed the cam-shaft and cam ready to push up on the valve-operating rod, which, when pushed up, actuates the rocker arm *D* to push down the valve proper, shown in the center at the top of the cut, against the action of the valve-spring *A*. While the valve is open, the charge is admitted in the case of the intake valve, or expelled in the case of the exhaust valve, during the period that the valve is kept open by the action of the cam. As soon as the cam has passed the lifter, the action of the valve-spring closes the valve with a sharp cut-off action.

Fig. 42 is a longitudinal view of the same engine, showing the inlet and exhaust valves *A* and *B*; also other details in connection with the ignition and cooling systems, whose positions it will be well to note now, but whose

action will be described more fully under the later discussions devoted to ignition and cooling systems respectively.

The modern tendency with respect to valves, both inlet and exhaust, is to provide quick action and abundant opening space. With this in view, some makers have adopted two valves in place of one, or, in some instances, exceptionally large valves.

Fig. 43 shows three views of an exceptionally large valve as used in the 1908 Franklin engine. Theoretically, the ideal cylinder

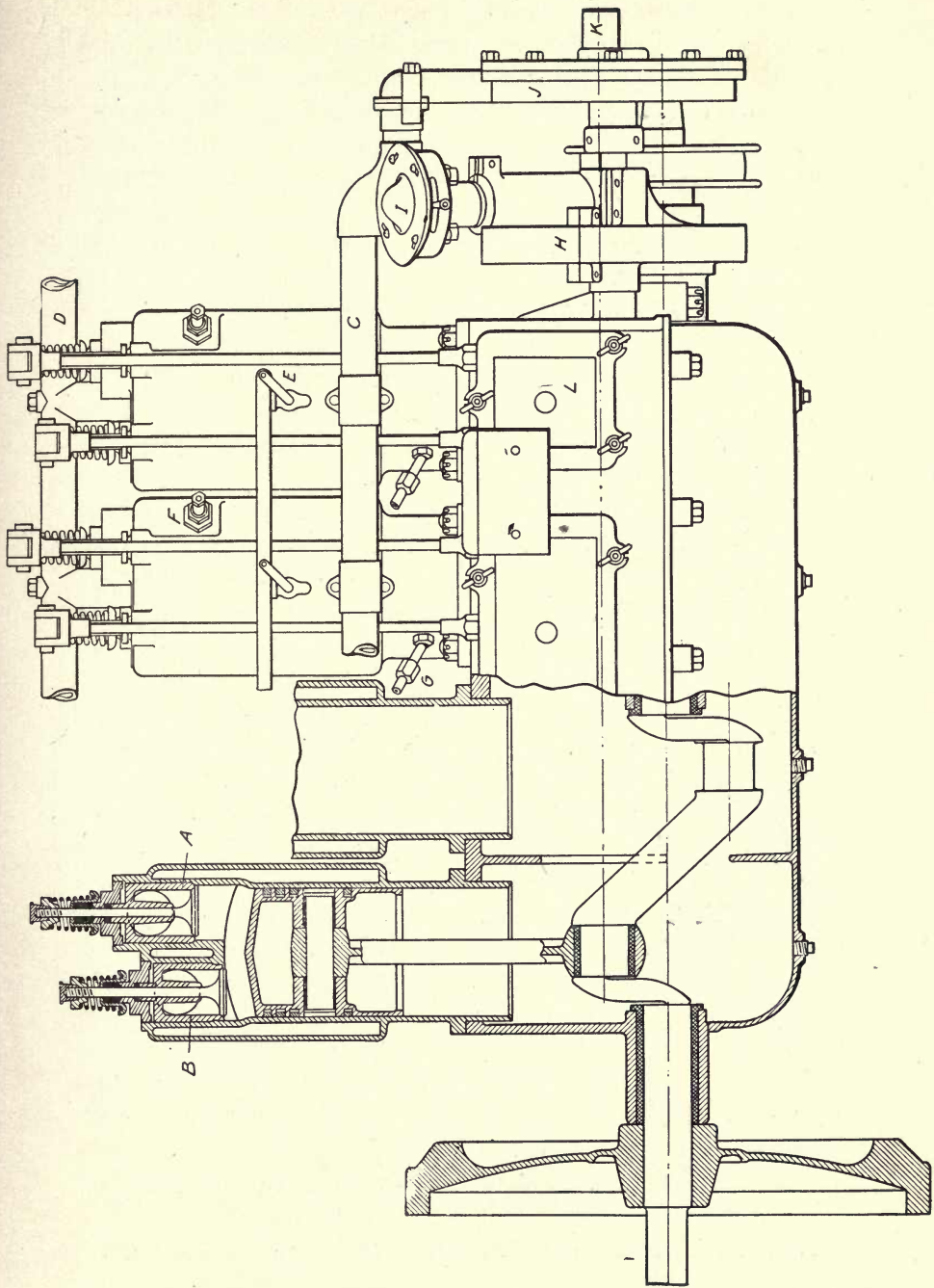

Fig. 42. Longitudinal Diagram of Rambler Engine.
 A—Inlet Valve; B—Exhaust Valve; C—Cooling Water Inlet Pipe from Pump to Cylinder Jackets; D—Outlet Water Pipe from Cylinder Jackets to Radiator; E—Relief Cocks; F—Spark-Plugs; G—Oil Pipes; H—Cam Gear Case; I—Commutator; J—Pump; K—Hand-Plates on Side of Crank Case; L—Pump Intake.

would be one whose entire top would come off to let in a full charge, and then close immediately, the charge being next compressed and exploded, driving the piston forward, whereupon the top would then at once come off completely again and let out the burnt gases. Fig. 43 shows a valve of about one-half the cylinder diameter in width, and directly at the top of the cylinder.

CARE AND OPERATION OF VALVES

Seating of Valves. If the exhaust valve does not seat properly, there will be a lack of compression and loss of power that way, and also a weakening effect on the mixture.

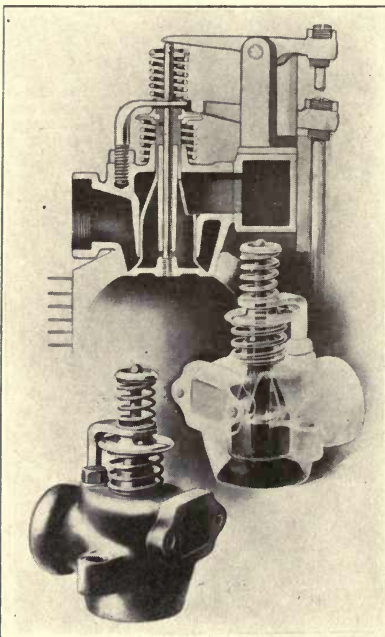

Fig. 43. Concentric Valve of 1908 Franklin Car.
H. H. Franklin Manufacturing Company,
Syracuse, N. Y.

If the inlet valve does not seat properly, there will be loss of compression; also there will be danger when the ignition takes place, of shooting back into the carbureter and having back-firing there.

The remedy is to grind the valves in place on their seats, first with emery and oil, and then with tripoli and water.

The valves, it may be, do not seat properly, because of being sooty or gummy. In this case they may not require grinding at all, the remedy being to clean them with kerosene.

In grinding valves, see that waste is placed in the opening to the combustion chamber so as to prevent the emery coming into the cylinder. The operation of grinding is repeated until both surfaces are bright and smooth, with a good fit.

Care must be taken that no emery gets into the cylinder, as this will cause sticking or seizing of piston.

Almost all valves have a slot on the side opposite the stem.

This slot is put there so that a screw-driver bit may be inserted, and with a brace the valve may be rotated to and fro while grinding.

In grinding, just a small quantity of the abrasive paste should be used at a time, with plenty of oil. Make ten or twelve turns in one direction; then reverse. Wipe valve and seat clean occasionally, and note the extent of the bright line. At first this will be irregular and broken. But it must become a continuous band for good seating.

After this has been accomplished, wash valve and seat thoroughly with kerosene.

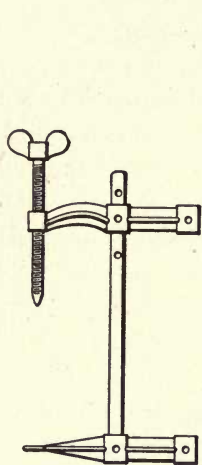

Fig. 44. Lifter Assembled.

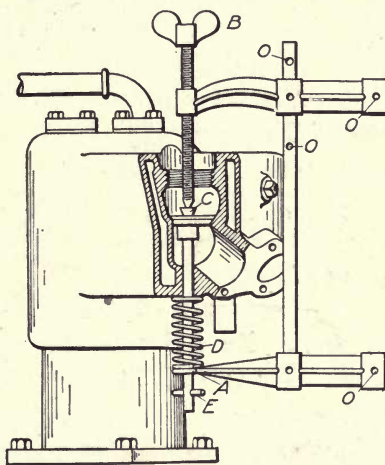

Fig. 45. Lifter Compressing Spring.

Tool for Removing Valve.

If valve is badly worn, it may be necessary to do some filing in order to avoid scoring and consequent catching.

Figs. 44 and 45 illustrate a convenient tool for removing valves. Its action is that of compressing the spring and lifting the washer so that the cotter or key can be removed. The directions for using this tool are as follows:

Place fork *A* beneath washer or in coil of spring *D*. Turn thumb-screw *B* until point sets on top of valve *C*. Then screw down until spring *D* is compressed enough to remove key.

To remove, back up on screw *B*, remove lifter, and take out valve, so that necessary grinding, etc. can be done.

To replace valve in position, simply reverse above instructions.

O represents adjusting holes adapted for different lengths of cylinders and for getting over or under exhaust pipes.

Timing of Valves. If the exhaust valve closes too early, there will be some compression left when the intake valve opens, blowing back through the carbureter and affecting the mixture, and also likely to cause firing in the carbureter.

If the exhaust valve should close too late, it would be open when the inlet valve is open, weakening the mixture in the cylinder.

If the exhaust valve opens too late, there will be back-pressure caused by the cylinder being full of the exhaust gas. The cam is so set that the exhaust valve opens just before the beginning of the exhaust stroke, so as to avoid this back-pressure.

Improper valve timing may be caused by looseness of the reduction gear driving the cam-shaft.

To Set Valve for Proper Timing. In a four-cylinder engine the four cranks are usually 180 degrees or half a revolution apart, so that there is an impulse or power stroke every half-revolution, occurring in the order of first, third, fourth, second.

The cam-shaft is driven by a gear fastened to the crank-shaft. The cam-shaft driving gear, mounted on the crank-shaft, has only half as many teeth as the cam-shaft driven gear which is mounted on the cam-shaft. Hence, for one revolution of the crank-shaft, the cam-shaft turns only through half a revolution. The cams are usually all keyed to the cam-shaft, or a part of the same, so that the adjustment of the cam-shaft with respect to the crank-shaft, if correct for one valve, is correct for all the valves.

The highest grades of motors have the cam-shafts and cams made of one piece of steel so that there is no disadjustment possible.

The first thing to do in valve-setting is to establish the *dead center lines* on the fly-wheel. This is very easily done on a four-cylinder engine or two-cylinder engine, since the points on the fly-wheel will be diametrically opposite. In the diagram, Fig. 46, the dead center lines are shown by the vertical and horizontal lines respectively. By establishing these points and chalking the fly-wheel and the cylinder flange, and then marking the points on the fly-wheel and the cylinder flange with a scribe, the scribe mark on the fly-wheel and cylinder flange will coincide when the pistons of the first and fourth or second and third cylinders, as the case may be, are at the highest point of their travel, or on their head-end dead centers, respectively.

The diagram shows the angles past the dead center lines at which the suction and exhaust valves usually open and close. It is well to determine these angles and mark them permanently on the fly-wheel when the engine is new and in first-class running condition. The diagram shows that the suction opens about five degrees past the dead center line, and closes thirty degrees past the opposite dead center. The first two strokes represented by one complete revolution in the direction of the arrow, represent the suction and compression strokes. The next half-revolution represents the explosion and expansion stroke. The fourth half-circumference represents the exhaust stroke, and the exhaust valve opens at a point fourteen degrees past the dead center line, closing at the end of the fourth stroke on dead center.

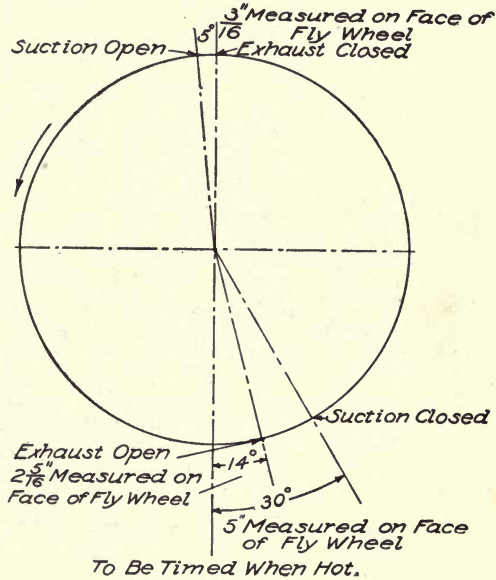

Fig. 46. Diagram Showing How to Use Fly-Wheel to Regulate the Setting of Valves for Proper Timing. The angles indicated vary with different engines, distances along circumference as indicated in inches apply to a fly-wheel 19 inches in diameter.

To determine the instant at which valves are moved, insert a finger into the cylinder, and feel whether the valve is on its seat and does not turn freely. In some engines this can be done by inserting the finger through the spark-plug hole, as shown in the sectional view of the two-cylinder engine, Fig. 47. In other engines it may be necessary to remove the exhaust pipe in order to determine a movement of the valves. If the events are all relatively out of time, estimate how many teeth the cam-shaft gear will have to be turned in relation to the driving gear to bring the events correct. Having done this, chalk and number the gear teeth, and, removing the crank-shaft gear and keeping the crank-shaft stationary, rotate the cam-shaft gear one tooth or more in the proper direction. Then

replace the driving gear, and retest. This is the course to pursue if a valve is opening too early and closing too early, or opening too late and closing too late, which is a sure indication that the cam-shaft does not bear the proper relation to the crank-shaft. If events of opening and closing of valves are not regularly out of time, the remedy does not lie in the adjustment of the cam-shaft, but in the adjustment of the individual valve push-rods. Provision for lengthening or shortening these is made in different ways in different engines; and

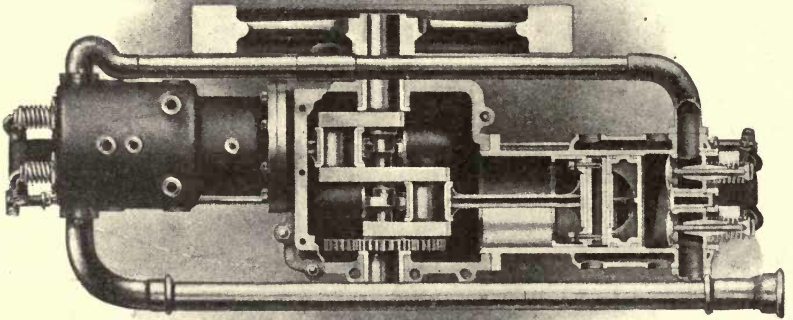

Fig. 47. Section of Two-Cylinder Engine Permitting of Access to Valves through Spark-Plug Hole.

this lengthening and shortening must be done for such individual valves as lift or close out of time, until all the events occur in uniform sequence—that is, until the angles past the dead center lines are the same for each valve.

Poor Compression. To improve compression, see that valves are not leaky; that is, regrind them, if necessary, until they seat perfectly and there is no leak. See also that there is sufficient oil, but do not supply a surplus of oil. Use just as much oil as can be used without causing smoke or carbonizing. Too much oil will cause the exhaust valves to become choked up.

A small pressure-gauge is applied to the spark-plug hole in the

cylinder, in order to test for compression. Note the gauge reading when cranking slowly. In testing for leaks, soap-water is injected at all points suspected, and the location of the bubbles will indicate the points of leak.

Another cause of lack of compression may be the sticking of piston-rings, due to corrosion or carbonizing. Cleaning with kerosene is the remedy.

The compression may also be weakened by a leak at the base of the spark-plug.

Overheating is likely to be accompanied by bad compression.

The easiest way to test for poor compression is by cranking. If there is but little resistance, the compression is weak.

Corrosion. To remove corrosion in cylinders, put kerosene into them, and let it remain over night. At the end of each week, it is well to put in each cylinder a half-pint of kerosene; and in the morning, by opening the compression relief-cocks, the kerosene can be blown out of the cylinders. If cylinders are hardened with corrosion, it must be scraped out.

For removing corrosion, Mr. C. T. Ziegler, who conducts one of the most prominent selling agencies in Chicago, recommends a mixture consisting of two-thirds paraffine oil and one-third kerosene. He states that he has found this more effective than anything else in removing hard substance.

To have as little corrosion as possible, it is advisable to use only the highest grade of mineral oil.

COOLING SYSTEMS

The Air-Cooled Engine. As the efficiency and consequently the power of a gas engine depend on the temperature difference at the end of the stroke below that at the beginning, it will be seen that the more perfect the cooling system, other things being equal, the more efficient will be the engine, and the greater power per cylinder will it develop.

It is noteworthy that but a few years ago air-cooled engines were not considered a possibility for high power, as the limit to be reached in a 4 by 4-inch cylinder was about 5 horse-power. Larger cylinders were found to get too hot and to subject the metal to too great strains, besides burning up the lubricant. As compared with

this rating of a few years ago of 5 horse-power per cylinder for the air-cooled engine, which rating may still be found in many textbooks on gas engines and automobiles, it is interesting to note how improvements in air-cooling have enabled the manufacturers of the Franklin car to build a $3\frac{1}{4}$ by $3\frac{1}{4}$ -inch engine with a capacity of 12 horse-power to the cylinder.

The air-cooled type of engine is being used on a good many popular and successful cars; and the growing percentage of all American cars using air-cooled motors is certain evidence of the improve-

ment of this type of engine.

Fig. 48 shows a single-cylinder air-cooled engine as used in the Orient buckboard manufactured by the Waltham Manufacturing Company, Waltham, Mass.

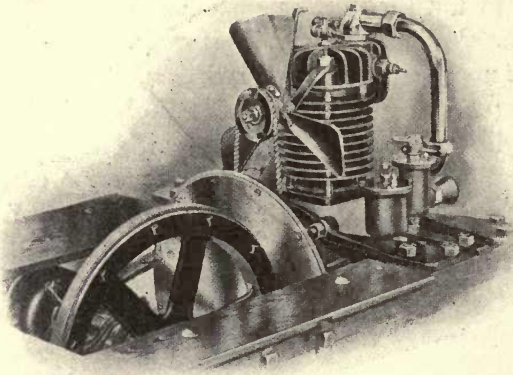

Fig. 48. Single-Cylinder Air-Cooled Engine as Used in Orient Buckboard. Waltham Manufacturing Company, Waltham, Mass.

Fig. 49 shows a two-cylinder opposed air-

cooled motor with 4 by 4-inch cylinders, as used in the Holsman Automobile, Chicago. It lies lengthwise of the car. Special features of this engine are a double set of spark-plugs wired up so that a snap switch turns off one set and turns on the other; also cylinder-heads screwing into the cylinders instead of being fastened on by studs, thus facilitating quick removal and replacement of the cylinder-heads. The flat spokes of the fly-wheel act as a ventilating fan.

Fig. 50 shows the exhaust side of the Franklin six-cylinder engine. The illustration shows the regular exhaust pipe from the top and the auxiliary exhaust pipe from the bottom of the cylinders.

Fig. 51 shows the 1908 Franklin engine in "phantom" drawing, showing all the working mechanism. The large intake valve and

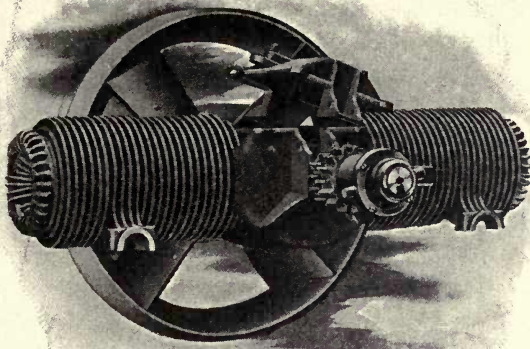

Fig. 49. Two-Cylinder Opposed Air-Cooled Engine as Used
in Holsman Automobile.
Holsman Automobile Company, Chicago, Ill.

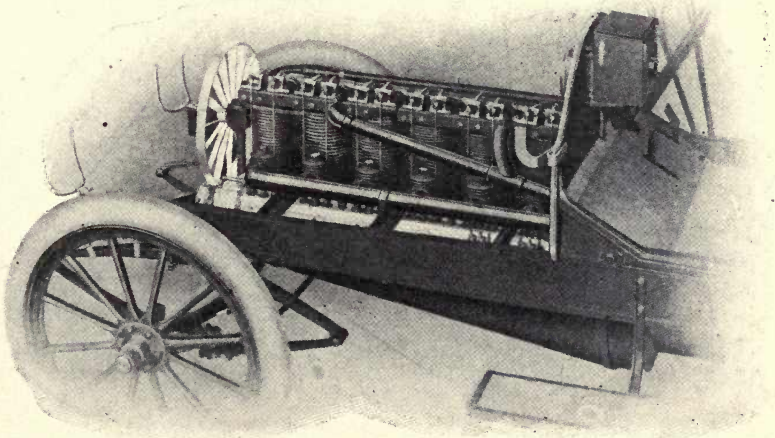

Fig. 50. Exhaust Side of Franklin Six-Cylinder Engine, Showing Regular Exhaust
Pipe from Top and Auxiliary Exhaust from Bottom of Cylinders.
H. H. Franklin Manufacturing Company, Syracuse, N. Y.

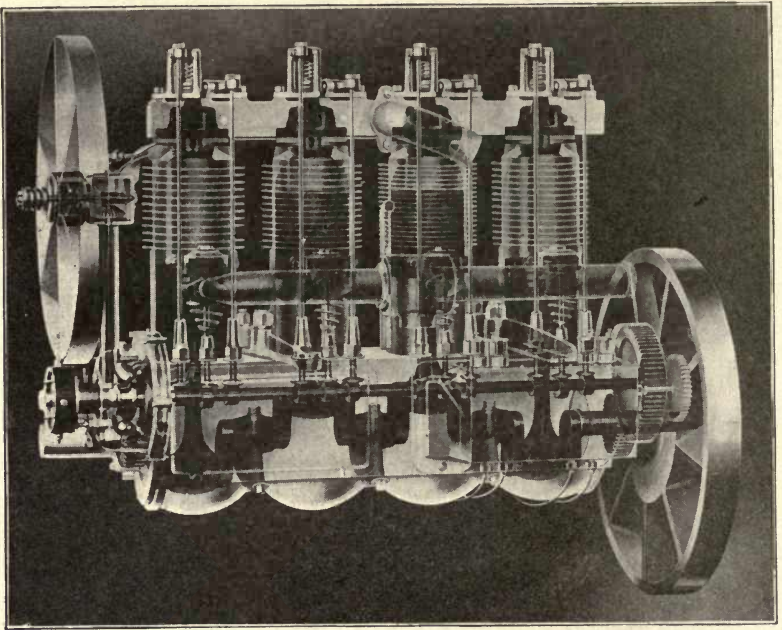

Fig. 51. "Phantom" Drawing of 1908 Franklin Air-Cooled Engine.
H. H. Franklin Manufacturing Company, Syracuse, N. Y.

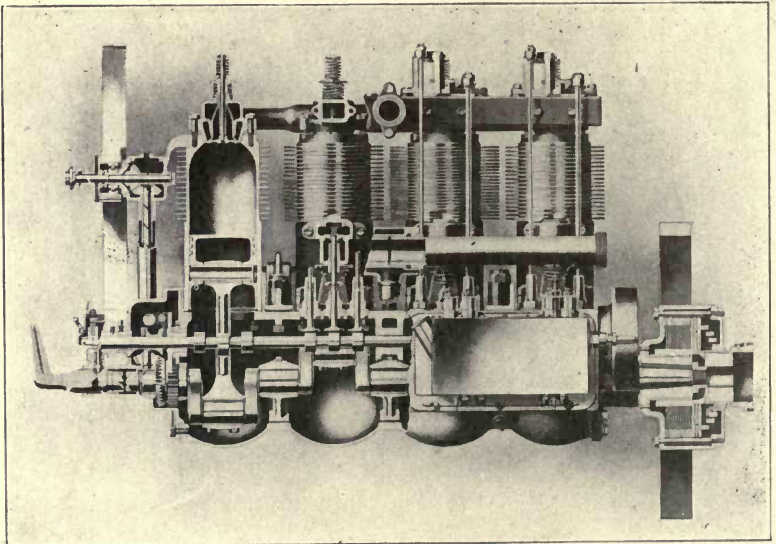

Fig. 52. Sectional View of Franklin 1908 Engine.
H. H. Franklin Manufacturing Company, Syracuse, N. Y.

auxiliary exhaust valves have already been mentioned. Another feature of this engine is the two fans—a gear-driven fan in front, and a fly-wheel suction fan in the rear. Fig. 52 gives a sectional view of the same engine.

In the Frayer-Miller motor, manufactured by the Oscar Lear Automobile Company, Columbus, Ohio, a centrifugal blower positively driven by the engine crank-shaft forces a directed current of

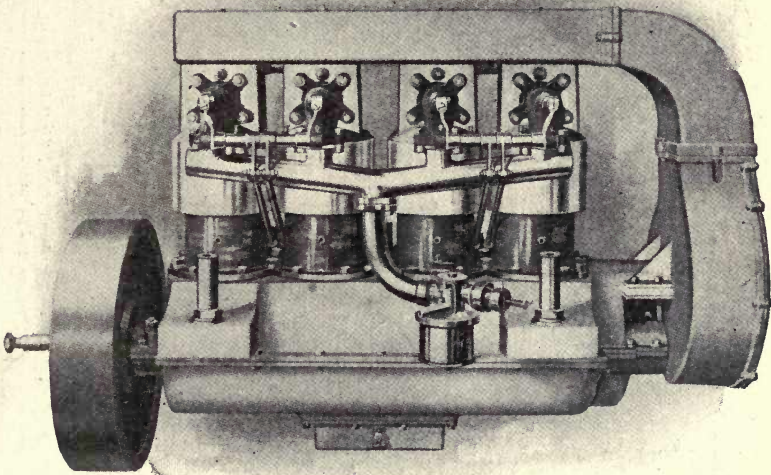

Fig. 53. External View of Frayer-Miller Engine Cooled by Centrifugal Blower, Inlet Side. Oscar Lear Automobile Company, Columbus, Ohio.

air over and around the cylinder heads, walls, and valve-seats, in the direction required to produce most effective cooling. This results in an increased amount of draft as the engine speed is increased; also in a positive draft whether the car is in motion or standing still. Fig. 53 is an external view of this motor, showing the inlet side. The centrifugal blower, with its enclosed air-blast pipe, is seen at the right. Fig. 54 shows the same motor in section. The centrifugal blower is geared to the crank in a ratio of 4 to 1. The starting crank is attached to the blower shaft; and it is therefore easier to crank the motor in starting, on account of this 4-to-1 gear.

A description of air-cooled motors would not be complete without mention of the *revolving-cylinder motor* as used in the Adams-Farwell car built by the Adams Company, Dubuque, Iowa.

Fig. 55 is an external view of this motor; Fig. 56 shows the motor in its mounting in the frame; and Fig. 57 is a diagram illustrating its operation.

The cylinders revolve around a common center—the vertical stationary crankshaft. The pistons and connecting rods revolve around another common center—the single crank-pin. The rotating cylinders throw off the hot air by the action of the centrifugal force, thus doing away with the necessity for a fan. The weight of the revolving cylinders serves the same purpose as a fly-wheel. By doing away with fan and fly-wheel, the total weight required is less than in engines of ordinary construction.

Water-Cooling Systems. In water-cooled engines the cooling system consists of a water storage tank, connected by pipes to a circulating pump, from which pipes connect to the cylinder jackets, which open, at a point remote from the inlet pipe, to outflow pipes leading to the top of the radiator, back of which is a suction fan.

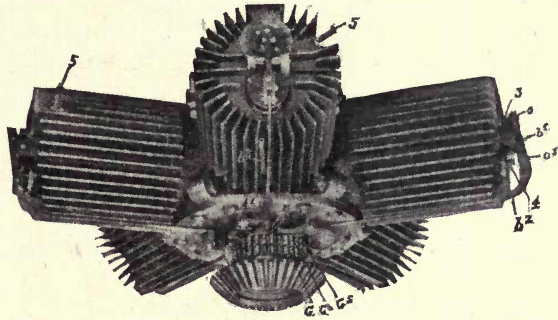

Fig. 55. Bottom View of 63-H. P. Revolving-Cylinder Motor of Adams-Farwell Car, with Cast-Iron Cylinders and Longitudinal Cooling Flanges. Adams Company, Dubuque, Iowa.

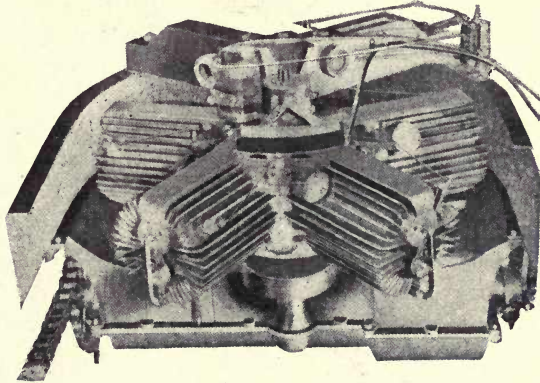

Fig. 56. Revolving-Cylinder Motor of Adams-Farwell Car, in Mounting on Frame. Adams Company, Dubuque, Iowa.

Fig. 58 shows a water-cooling system designed for a four-cylinder engine with independently cast cylinders. Fig. 59 shows a system for the twin-cylinder or "cast-in-pair" type of construction. Both of these diagrams show systems in which the radiator itself is the only storage tank. A good many cars have a storage tank for water, in addition to the radiator.

Referring to Fig. 58, it will be noticed that from the lower part of the radiator a tube runs to a water-strainer, which is an easily opened receptacle containing a small disc of wire gauze preventing the passage of sand and dirt into the water pump. The strainer is also provided with a cock for draining the entire water system. Most water systems provide also a cock in the pipe, just underneath the radiator. In draining the water system, be sure that both these cocks are opened; otherwise

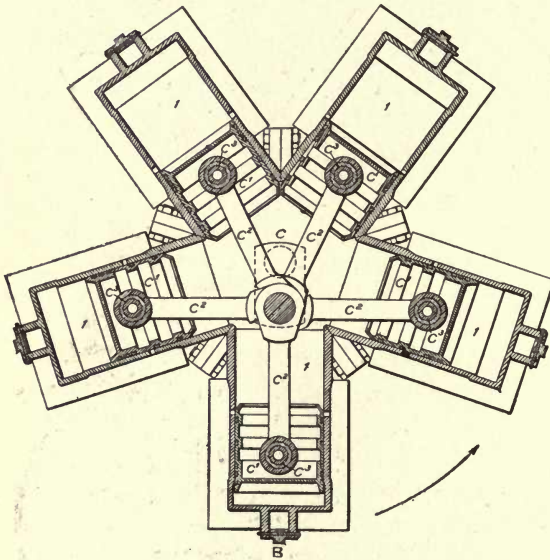

Fig. 57. Diagram Showing Operation of Adams-Farwell Rotating-Cylinder Engine. Adams Company, Dubuque, Iowa.

some water will remain in the system, which might result in freezing in cold weather.

Rubber hose connections in the water system are a source of great annoyance, and are being discontinued in the best cars, where they are being replaced by copper pipes with ground connections. Copper tubing, though longer-lived than rubber hose, has also disadvantages due to its liability to corrosion. Aluminum tubing has been used by some makers, though not to sufficient extent as yet to determine whether it can be recommended as the most desirable flexible tubing or not.

In order to insure the clearness of water in the water-circulating

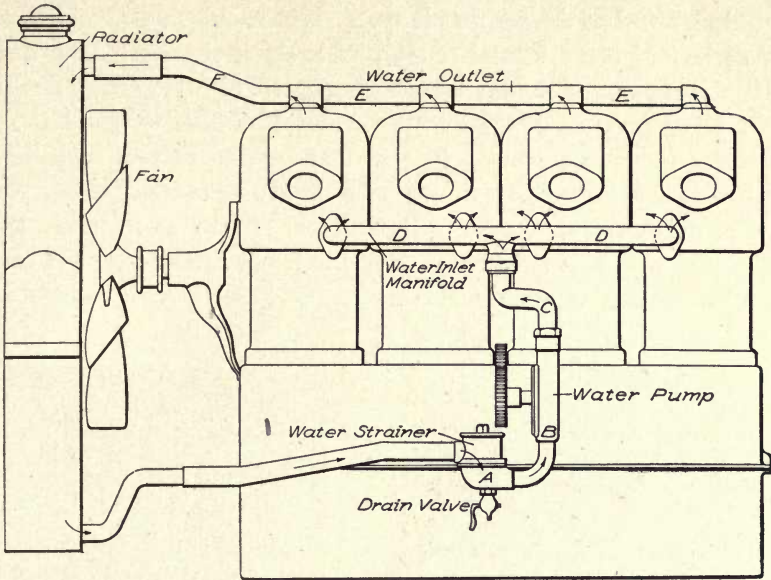

Fig. 58. Water-Cooling System for Separately Cast Cylinder Engine. E. R. Thomas Motor Company, Buffalo, N. Y.

system, a hose attached to city water should be allowed to pour into the water tank, the drain-cocks being left open and the engine kept running for some ten minutes, or until the outflowing water is perfectly clear and clean.

Radiators are either *tubular* or *cellular*, the latter class being

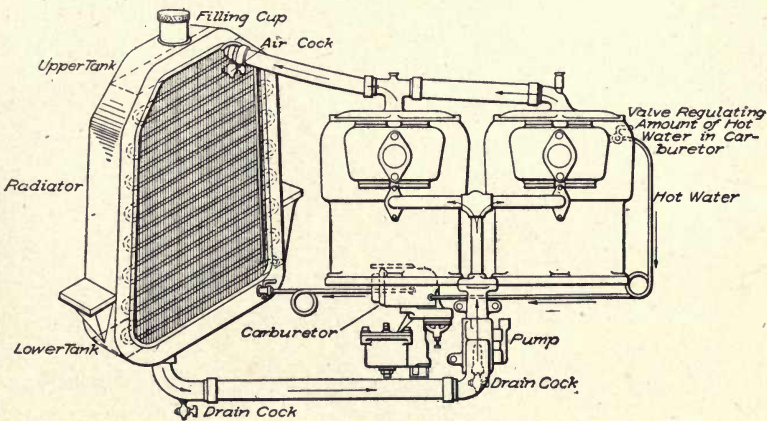

Fig. 59. Water-Cooling System for Twin-Cylinder Engine. Peerless Motor Car Company, Cleveland, Ohio.

also designated as the *honeycomb* type. The tubular type consists of either vertical or horizontal tubes, preferably of circular section and of rapidly radiating material (such as copper), with projecting fins or washers to assist in dissipating the heat. The tubular type has an advantage over the cellular type in that its construction is usually such that if a leak occurs in one tube the entire radiator is not put out of commission. In the cellular type, on the other hand, the main aim of the construction is to secure free play and flow of water in all directions through a continuous body of water, by means of

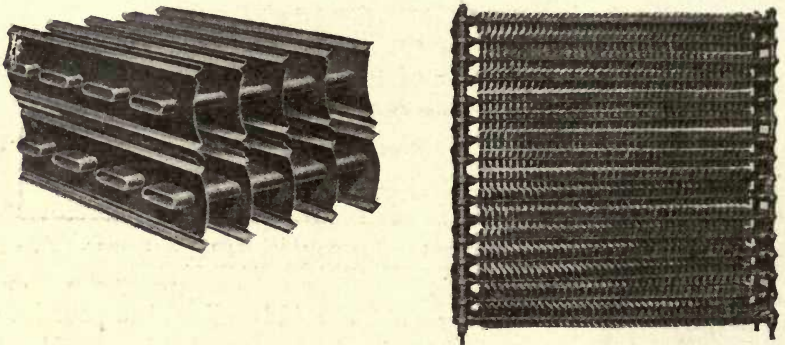

Fig. 60. Tubular Radiator, Showing Sectional and Separable-Construction Flat Tubing and Large Radiating Fins.
Reo Motor Car Company, Lansing, Mich.

lateral joints. This type of radiator is more efficient than the tubular, but more fragile. Fig. 60 shows the Reo tubular radiator; and Fig. 61, the Mayo cellular radiator.

Pumps are almost universally of the gear type, the water being lifted by the pressure of gear teeth against each other. A few cars use pumps with flat or square pistons, but the gear type is superseding these. In early cars, both pump and fan were belt-driven, but recent practice is in favor of gear drive from the cam-shaft.

The gear type of pump has an advantage over the piston type in that the strain is not periodic but is uniform throughout the entire revolution. Fig. 62 shows the principle of operation of the gear type of pump.

Still another method of circulation is used in the Maxwell car, known as the *thermo-siphon* method, which is simply a siphonage in place of a pump. The circulation, depending entirely on tem-

perature difference and not on engine speed, is greatest when the engine is hottest, which may be when its speed is low, as in going up a hill.

Fig. 63 shows the Peerless engine, giving a view of the encased

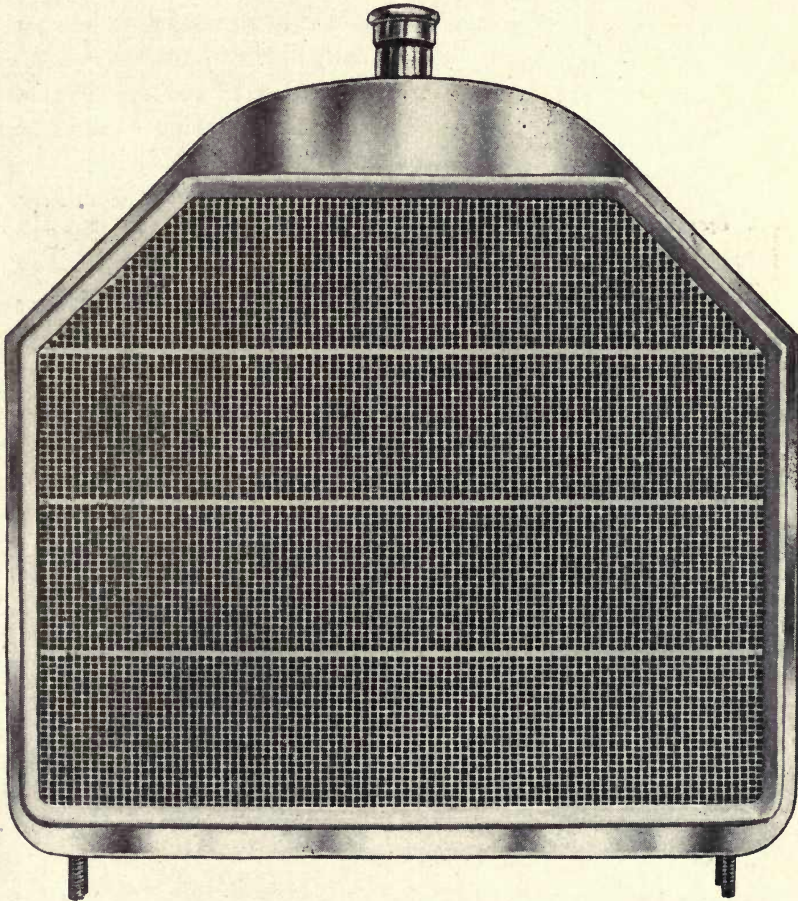

Fig. 61. Mayo Cellular Radiator of Type Used in Stearns 30-60-H. P. Cars.
Mayo Radiator Company, New Haven, Conn.

geared pump at the right, also the belt-driven cooling fan. The arrows indicate the direction of water circulation.

Gaskets. In all flanged joints where a flange fits to another flange or to a cylinder or pump-shell or any other part in a water line or steam line, a compressible piece is inserted between the two

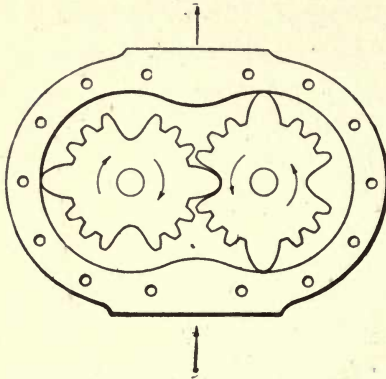

Fig. 62. Operation of Gear Type of Water-Circulating Pump.

metallic surfaces to make the joint tight against water or steam or whatever the circulating fluid may be. These compressible pieces are called *gaskets*. In steam-engine practice, gaskets are usually made of rubber or some composition of rubber, asbestos, and cotton. Owing to the high temperatures of gas engines, rubber composition gaskets are not so satisfactory as metallic gaskets.

Fig. 64 shows types of copper-asbestos gaskets made by McCord & Company, Chicago.

In emergencies, gaskets are easily made out of any stiff brown paper covered with graphite. The addition of graphite to a stiff brown paper makes the paper quite brittle; and in fitting it to the

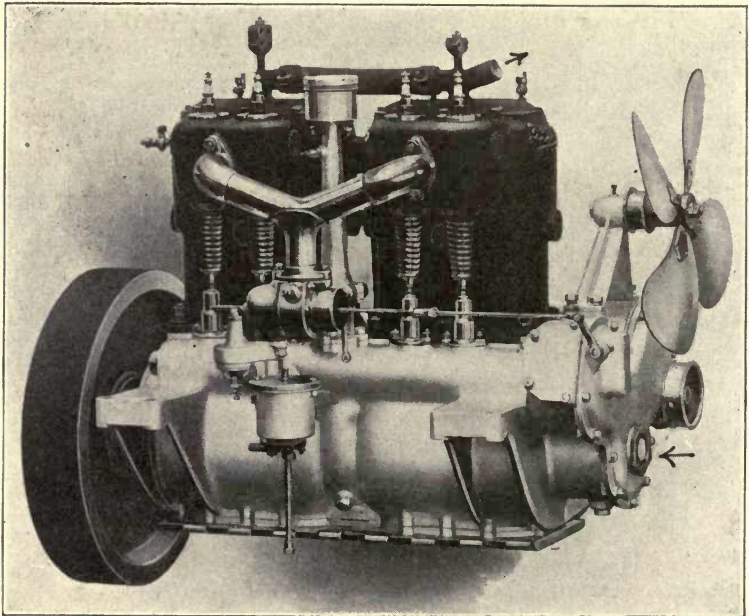

Fig. 63. Peerless Engine, Showing Cooling Pump and Fan. Peerless Motor Car Company, Cleveland, Ohio.

flange, it can be hammered into form, and the projecting part broken off with the hand.

If a gasket gives way in the cooling-jacket connection, it is apt to result in the jacket not receiving enough cooling water, owing to the leak. In such a case a temporary gasket of paper should be inserted. A leaky gasket can be detected while the car is running, by a hissing sound, if in the cylinder. If the leak is between the

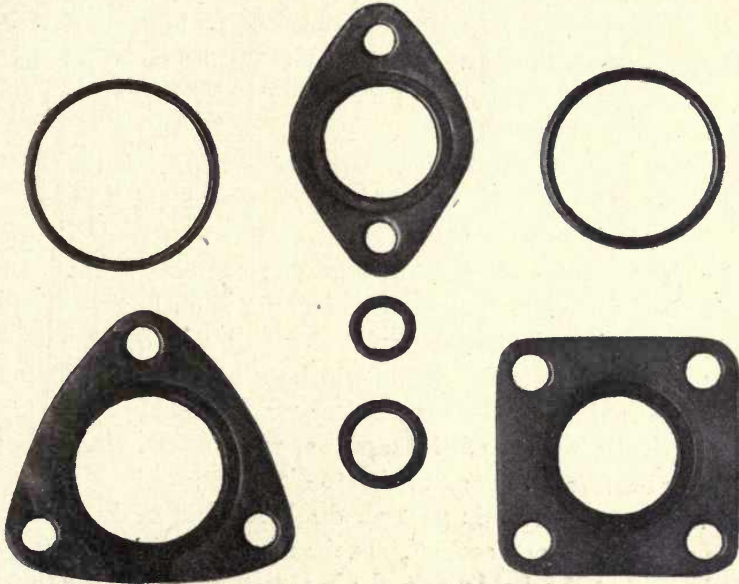

Fig. 64. Types of McKim Copper Asbestos-Lined Gaskets.
McCord & Company, Chicago, Ill.

water-jacket and the cylinder, the engine will miss explosions if cooling water gets inside the cylinder.

Water in the cylinders can be detected by opening the pet-cocks and rotating the engine by the starting crank. Sometimes it is apparent from steam issuing from the muffler when the engine is running. If, after tightening all of the studs and nuts holding the engine-head to the cylinder, the leaking continues, a new gasket is necessary. To apply it successfully, the surfaces of the cylinder-head and cylinder should be thoroughly cleaned with gasoline, and any foreign material removed either by washing with gasoline or by scraping. The surfaces of both head and cylinder should next be

coated with silicate of soda, and allowed to dry thoroughly. The gasket should then be soaked in the soda (if it is of asbestos or asbestos composition), and allowed to dry partially. If of paper and a temporary makeshift, it should be coated with graphite. Place the gasket on the cylinder, put the head in place, and tighten the studs and nuts. In doing this, be careful to distribute the pressure evenly—that is, tighten each stud and nut only a little at a time, until they have all been set home. After doing this, start the engine, and allow it to run one or two minutes without water in the tank. Stop it, tighten the studs and bolts again, and fill the tank with water. Do not use too long a wrench in tightening, and do not use too much force at once.

Overheating of Engine. When overheating occurs, everything begins to rattle and knock. You have premature ignition. It makes a “pinging” sound. The mixture ignites from the heat, instead of from the spark. If allowed to continue running when overheated, the engine will transmit its heat to oil in the cylinders, and if hotter than the burning point of the oil, the oil will burn and its odor will be noticed. Steam will be seen emanating from the cap of the radiator. The car will lose power and slow up. Overheating causes expansion of the piston, while at the same time all the parts become weaker and liable to distortion.

When overheating is noticed, the best thing to do is to shut down and let the parts cool off. In the case of an air-cooled engine, this is all that can be done; and after starting again, be sure that your mixture is not too rich or too plentiful. Before starting, disconnect the spark-plugs, and crank the engine a while so as to draw cool air through the cylinders. In the case of a water-cooled engine, some people would advise running the engine with spark well advanced, throttle closed, and engine free. This would cause rapid circulation of the water, which has previously been cooled by drawing off a part of it and putting in some cold water. This would be the course to pursue in case the overheating had been caused by working the engine too hard, and not because of lack of water. If water has all been used up, or if radiator and jackets are full of steam, avoid causing a sudden chill by pouring in cold water. Such a chill is likely to cause cracking of parts.

Other causes of overheating are found in defects in the water-

circulating system, such as the failure of the pump to work, the presence of some obstruction in the water pipes, such as a piece of solder, or a leak in the water line. Overheating is also sometimes due to too rich mixture in the carbureter. A strainer should always be used in pouring in water, so as to prevent any dirt or grit getting into the pump or pipe-line.

A piece of rubber tubing is useful to carry as a temporary repair to leaks.

What is known as an *air-lock*, caused by air-bubbles in the pump, may impede water circulation. The remedy for this is to let the water flow out, and to keep pouring in new water.

Steaming Radiators. If the water in your radiator manifests a disposition to boil, and the gathering steam blows the filling cap off, do not try to cure the trouble by using an extra supply of solder on the cap. The pump or its driving connection may be broken; or a pipe or strainer may be clogged by waste or by a chance stone; or the carbureter may be feeding an excessively rich mixture; or there may be oil in the radiator, preventing contact of the water with the cooling metal surface.

Care of Water-Cooling System in Cold Weather. In freezing weather, it is very important that the engine be not stopped while the car is left out in the open; and that when the car is put away in its storage place for the night, all the water be drained out if exposed to freezing temperature, unless the circulating system is filled with a non-freezing mixture. There are various kinds of non-freezing mixtures on the market. Good mixtures can be made in the following ways:

1. A 50 per cent solution of wood alcohol.
- 2 Put 10 lbs. of chemically pure chloride of calcium and a handful of unslaked lime into a pail of water. After this preparation is carefully mixed and dissolved, pour into the radiator or tank through a strainer.
3. A 40 per cent solution of glycerin and water.

GASOLINE SYSTEM

The gasoline or fuel system consists of the *gasoline tank*, which is sometimes provided with a reserve or emergency chamber, and usually with a dirt or sediment chamber; *piping*, leading to mixer or carbureter; the *carbureter* itself, which will be described more fully

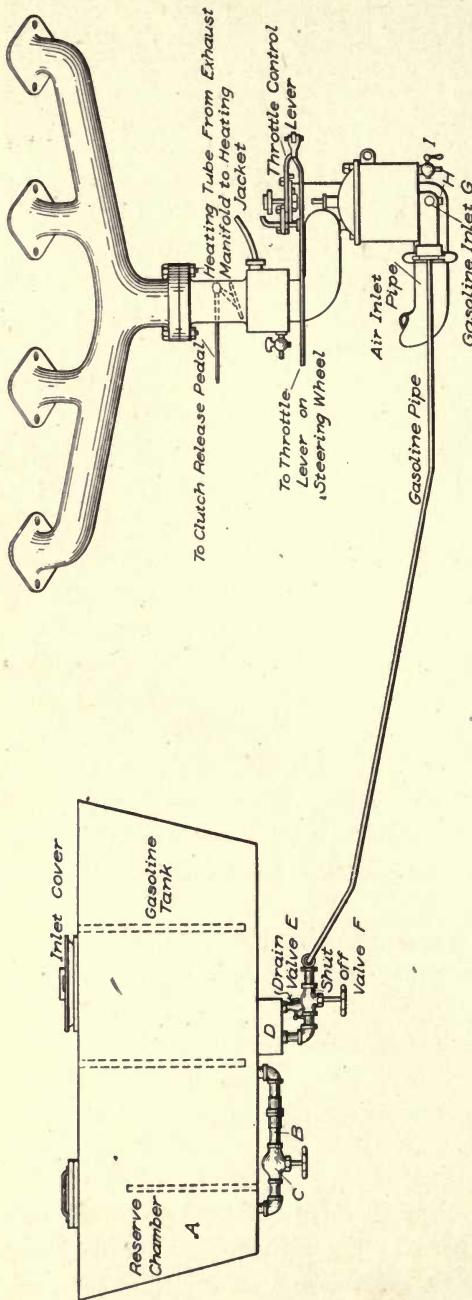

Fig. 65. Gasoline System of Thomas Flyer. E. R. Thomas Motor Company, Buffalo, N. Y.

in detail; and pipes leading from the carbureter to the valve-chambers of the engine, the piping being provided with necessary cocks and control valves.

Fig. 65 shows the gasoline system of the Thomas Flyer, made by the E. R. Thomas Motor Company, Buffalo, N. Y. The *gasoline tank* is placed under the forward seats, and contains twenty gallons. On the extreme left of the tank, a *Reserve Chamber (A)* is partitioned off. It is connected by a pipe *B* to the main chamber. The valve *C* in this pipe should be kept closed until it is necessary to admit the gasoline in the reserve chamber, which holds one gallon. The *sediment and water receptacle (D)* is shown at the bottom of the tank, which is drained by the valve *E*. There is also a shut-off valve in the line to the *carbureter (F)*, which should be closed after the day's run, so as to cut off the

gasoline supply from the carbureter, as the gasoline might overflow past the needle-valve, and, evaporating into the room, might cause a vapor which would prove dangerous on striking a match.

Fig. 66 shows the gasoline system of the Peerless motor-car, Cleveland, Ohio, giving a little more detail than is shown in the previous figure. In this system the filter and sediment catcher are in the pipe-line at its lowest point. Beyond this filter is an additional shut-off valve in the line to the carbureter. It will be seen that the mixing chamber of the carbureter is surrounded by a water-jacket connected to the regular water system. The water coming from the heated cylinders warms the mixture.

Gasoline Tank. Water or sediment in the gasoline is likely to cause a great deal of trouble in case it gets into the pipe-line or carbureter. Where the gasoline tank is not provided with a sediment drum, particular care needs to be taken not to substitute a cork or a wooden plug for the metal cap of the gasoline tank, or, in case a leak has been repaired, to see that all solder is cleaned out. The best remedy in case the gasoline tank has no drum, is to provide one. The gasoline intake leading to the carbureter leads from this drum, which is a small projecting cylinder at the bottom of the gasoline tank. The intake pipe should be screened, the gasoline rising upwards through the screen. There should be a cock or plug at the bottom of the drum, to permit of the withdrawal of any water or sediment that gathers there. Water, being heavier than gasoline, sinks to the bottom of the drum, and there is thus no danger of its getting into the carbureter. Another advantage is that gasoline will go into the drum up to the last drop.

As soon as the slightest leak manifests itself in the gasoline tank or line, it should be attended to. In putting out a gasoline blaze, much more effective results are obtained by throwing sand or dirt on the fire, than from the use of water. It is advisable to have several buckets of sand or salt on hand in an automobile garage, to use in case of emergency. Leaky gasoline pipes have been the cause of a number of heavy losses, and careful inspection of the pipe-lines should be made regularly.

Gauge-glasses on gasoline tanks, while at first sight appearing convenient, constitute an additional breakable feature which can be dispensed with, with very little inconvenience.

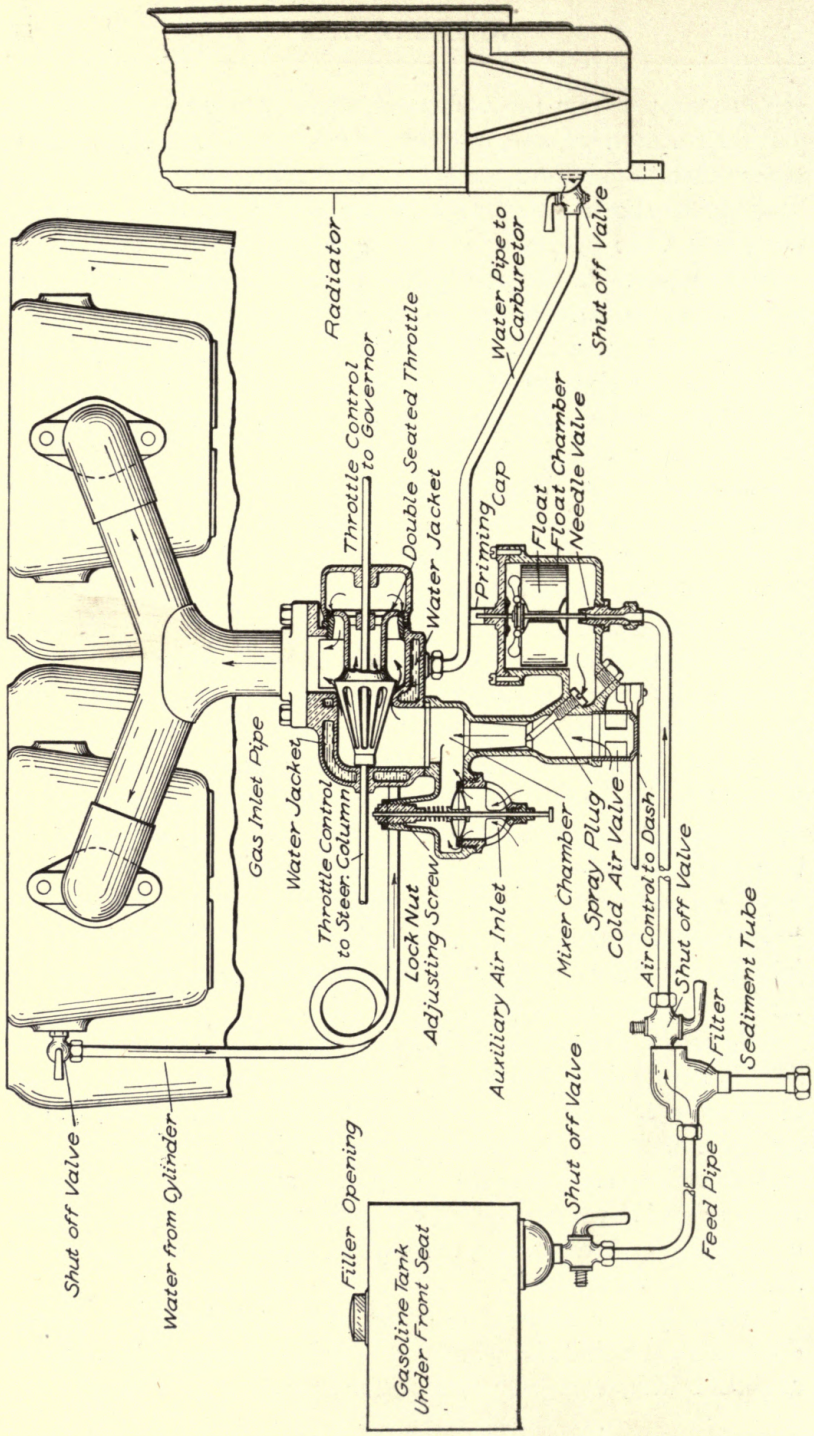

Fig. 65. Gasoline System of Peerless Car. Peerless Motor Car Company, Cleveland, Ohio.

Grades of Gasoline. What is known as *High-Test* gasoline is a variety of gasoline which possesses certain advantages in industrial processes. For general driving purposes it is not worth the advance in cost. It is easier of ignition than ordinary gasoline. There is not so much heat in it, nor so much mileage, as in ordinary gasoline. It does, however, explode more instantaneously, and hence gives power more quickly. It will not drive a car so long a distance as the same amount of ordinary gasoline.

Gasoline is graded according to its specific gravity expressed in terms of the scale on Baumé's hydrometer. Thus, gasoline graded at 65 or 85 degrees means that the hydrometer would sink to these figures on the scale. Baumé's hydrometer is the instrument generally used for testing specific gravity. To find the specific gravity, knowing the point on the scale to which the hydrometer sinks, we use the formula:

$$\text{Specific gravity} = \frac{140}{130 + \text{Hydrometer Reading}}$$

It will thus be seen that the higher the reading on the hydrometer, the lighter will be the gasoline. Ordinary gasoline is about 68 degrees; high-test, so called, is about 76 degrees.

It is worth knowing that when the engine is warm it will run on kerosene, although it may not start with kerosene when cold. Kerosene is not good for the spark-plugs, on account of the sootiness resulting from its use. But in cases of emergency where gasoline cannot be purchased but kerosene can be found, the car can be run so long as enough gasoline is kept to start the engine and get it warm.

Carbureters. The relative proportion of gasoline and air to give the most effective explosive mixture, is subject to some variations dependent on the weather. No fixed rules can be given that will apply to all types of carbureters. Hence it is extremely desirable that the operator of a car be thoroughly familiar with the principles of operation and methods of adjustment of the carbureter on his car, so that he can adapt it to varying conditions so as to secure the most effective results. The injunction "Don't change the adjustment of the carbureter," which used to appear in instruction books, was very poor advice, and resulted in unnecessary troubles and needless calls on the repair shop on account of carbureter adjustments.

Having once adjusted the carbureter for making a proper mixture for a certain kind of weather, the action of the carbureter itself **must** be automatic in maintaining this mixture under all varying conditions of engine speed and load. This self-regulation to maintain the proper mixture, is attempted in different ways in different carbureters.

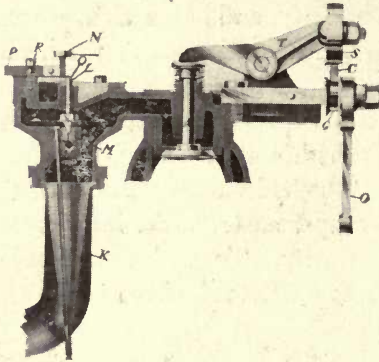

Fig. 67. Carbureter of Cadillac Single-Cylinder Car, Spring-Operated, without Float-Chamber. Cadillac Motor Car Company, Detroit, Mich.

The Cadillac Motor Car Company, Detroit, Mich., regulates it by means of spring action in a carbureter that is very simple, without any float-chamber.

Fig. 67 shows a section of this carbureter. Its action is as follows:

The air is taken in at the end of the inlet pipe *K*. The intake of the air caused by the suction of the piston lifts the valve *L* and forms a partial vacuum at the terminal of the gasoline passage *M*, the screw *N* being adjusted so as to allow the valve *L* to lift from its seat just far enough to admit the proper amount of gasoline to form with the in-going air the proper mixture. The adjusting screw *N*, which regulates the amount of gasoline, should be adjusted only in case of improper mixture.

To secure the greatest efficiency, the mixer valve (which admits the gasoline into the carbureter) must open wider when the engine is running at high speed than is necessary when running at low speed.

The method of this adjustment is shown in Fig. 68. When the adjusting screw is located as shown in *A*, the spring *Q* cannot act; hence the adjustment needs to be changed. In Fig. 68, *B* shows the spring free to act to its full limit. With this adjustment it will be found that when the engine is running at low speed, the needle-valve moves so slowly that it has not sufficient momentum to cause the spring to yield. When, however, the speed increases, the volume of air comes against the diaphragm of the valve at a more rapid rate, and causes the needle *L* to strike against the spring *Q* with such force as to make it yield, thus allowing the mixer valve *L* to open wider at this high speed than it did at low speed. Under these con-

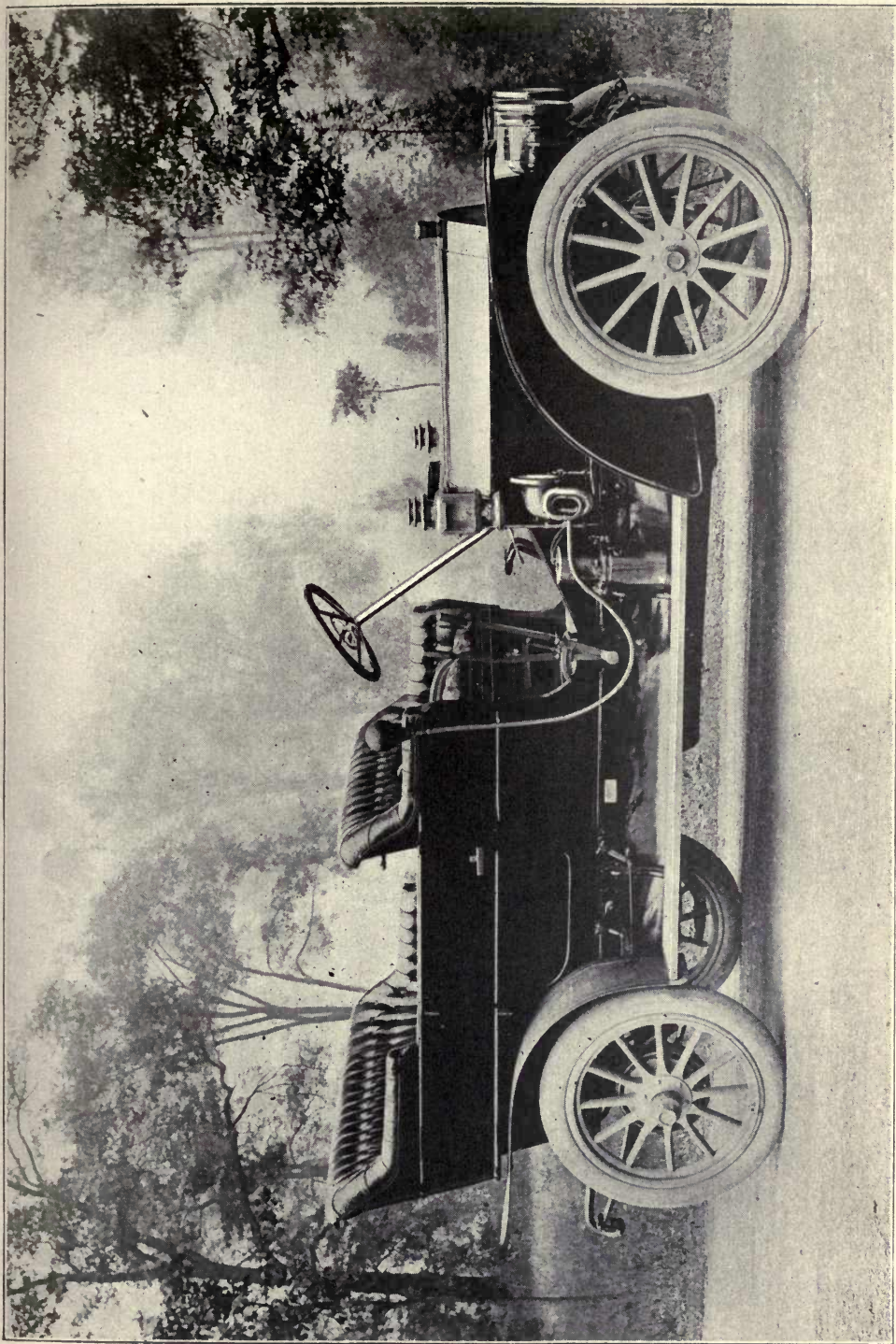

COLUMBIA FIVE-PASSENGER GASOLINE TOURING CAR, 29 HORSE-POWER, 1909 MODEL.
Electric Vehicle Company, Hartford, Conn.

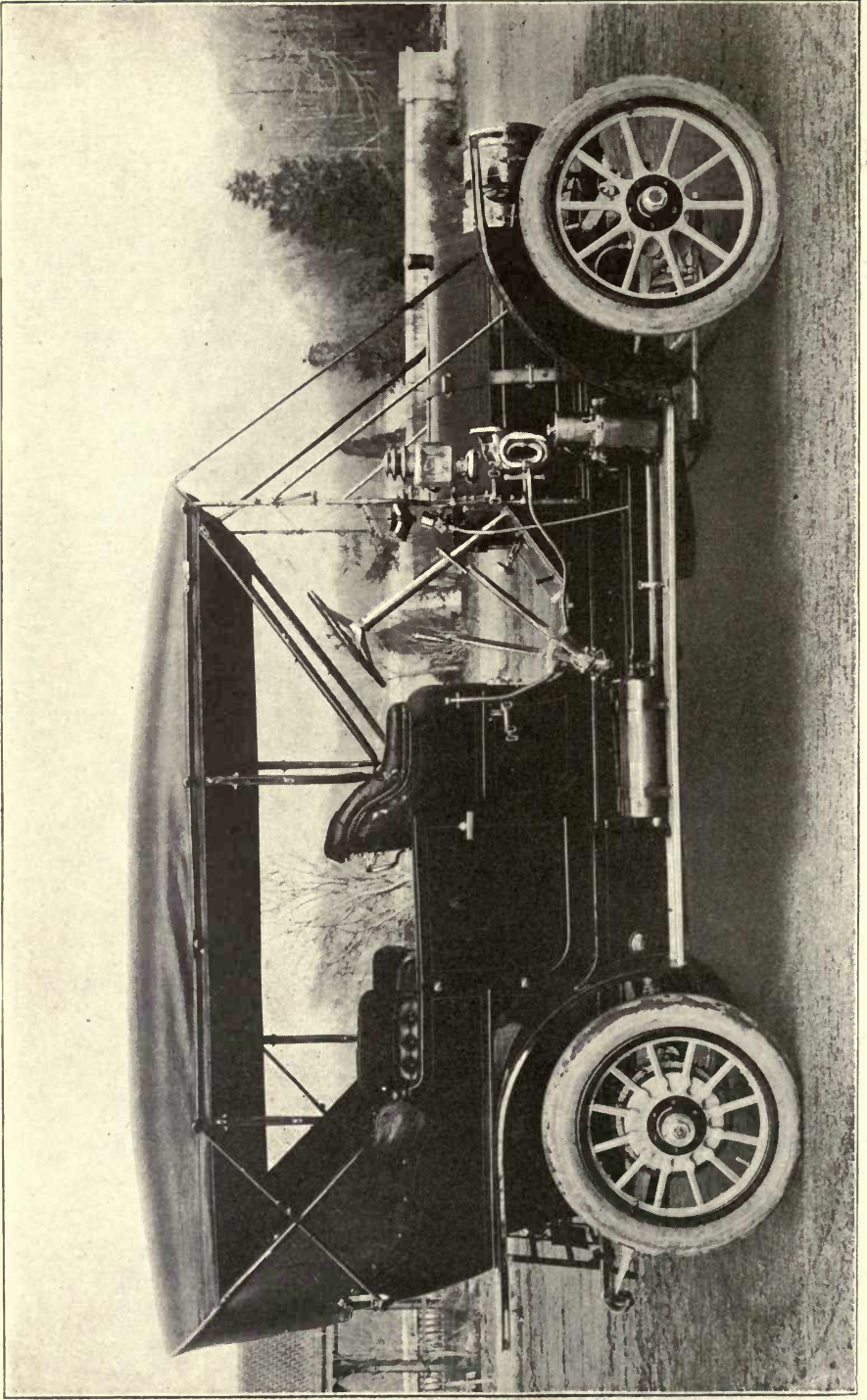

THOMAS FLYER.
E. R. Thomas Motor Company, Buffalo, N. Y.

ditions there is too much spring action, allowing the valve *L* to open too wide, and making the mixture too rich at high speed.

In this case the binder *P* must be adjusted so as to bring the adjusting screw *N* to the position shown in *C*, Fig. 68, giving less spring action than in *B*, and more than in *A*. By a little experimenting, the adjusting screw can be located in a position where it will allow sufficient spring action to give the desired mixture at both high and low speeds. The adjusting and experimenting should be done with the throttle wide open and with the spark-lever away back, so that firing does not take place ahead of dead center.

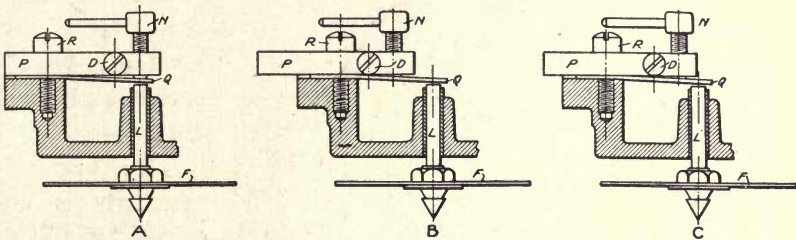

Fig. 68. Showing Adjustment of Spring Regulating Cadillac Carbureter. Cadillac Motor Car Company, Detroit, Mich.

The *float-feed* type of carbureter is very generally used; and a great many makes are on the market, with slight variations.

Fig. 69 is a section of this type of carbureter as used by the National Motor Vehicle Company, of Indianapolis. It is attached to the gasoline inlet line at the side of the engine, by an S-shaped brass pipe and flange. The *float-chamber B* of the carbureter contains a float *F*, which float actuates the gasoline inlet valve *H* by means of the float-lever *I* hinged at *J*. As the float-chamber fills with gasoline admitted through the inlet valve from the pipe-line leading to the gasoline tank, the float rises until it reaches a predetermined level, at which time it closes the inlet valve *H* through the action of the lever *I*. It will thus be seen that the connection to the gasoline tank is normally closed until the gasoline level falls sufficiently to cause the float to drop and operate the lever, thus permitting more gasoline to enter the chamber *B* until the normal level is again restored. The suction of the piston during the admission stroke of the engine creates a partial vacuum in the entire admission line, and this suction draws the gasoline through the spraying nozzle *D*. The

amount of gasoline passing through the nozzle is regulated by the needle-valve lever *E*. The gasoline jet from the nozzle passes into the mixing chamber *C*. The quantity of air entering into the mixing chamber is controlled by the compressing air-valve *A* adjusted against the spiral spring *O* by means of the adjusting screw *M*.

It will thus be seen that the mixture can be regulated as to quantity both of gasoline and of air, each being independently regulated.

The quantity of mixture which goes to the engine is controlled by the throttle-valve *K*, which is simply a metal disc turned by means

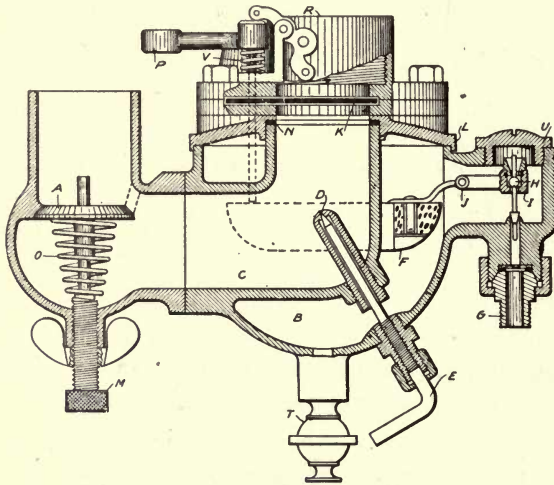

Fig. 69. Float-Feed Type of Carburetor, with Hand Regulation of Gasoline at *E* and of Air at *M*.
National Motor Vehicle Company, Indianapolis, Ind.

of the lever *P*, to which is attached the rod system leading to the operator at the front seat.

The proper mixture is obtained by adjusting the needle-valve *E*, which need be opened but slightly—usually only about three-fourths of a turn. If, when the cylinder relief-

cocks are opened, black smoke and flame are observed, the mixture is too rich. After a bluish flame has been obtained, and the firing is regular, open the throttle-valve gradually. If the engine runs at low speed and fires regularly, but misses on high speed, tighten the tension on spring behind automatic air-valve, by screwing in the adjusting screw *M* until the engine fires regularly on all speeds and no black smoke is seen coming out of the exhaust.

Flooding of the carburetor will be indicated by the stopping of the engine when running, or by the gasoline running out of the carburetor when the engine is standing still, and is due to the float sticking and its not closing the inlet valve to the carburetor *H*. This can be remedied by taking off the carburetor after shutting off the

gasoline by closing the cock below the tank. Remove the top of the carbureter, which shows the float to view. Its sticking is usually due to its binding on one side, it not being central. This can be remedied by loosening the screw in the center of the float, and moving the cork slightly to one side or the other.

Obstruction of the needle-valve of the carbureter will cause stopping of the engine or refusal to start. This is remedied by taking off the carbureter as above, and unscrewing the needle of the needle-valve, and then blowing through the valve. Such obstruction is generally caused by there being some particles of dirt in the gasoline.

Sometimes, if the car slows down from this cause, releasing the clutch and opening the throttle, allowing the engine to race for just a moment, it will draw this dirt out of the needle-valve. The disadvantage of this method is that the dirt is sucked into the engine cylinder, helping to score the cylinder by just that much.

In cold weather, water in the gasoline will freeze in the carbureter unless the carbureter is of the water-jacketed type employed in some cars. An almost imperceptible amount of water can cause this trouble, which can be detected by popping in the carbureter and perceptible cutting down of power of the engine, which acts as if the needle-valve of the carbureter were set for too little gasoline. When there is considerable water in the gasoline, it will stop the car entirely. This can be remedied by opening the cock at the bottom of the carbureter; and as the water is heavier than gasoline, it will drain out first. The cock directly under the gasoline tank should also be opened for a few seconds. If there is any suspicion about the gasoline in the tank having any water in it, it should be filtered through chamois skin.

Compensating Carbureters. The faster the engine speed, the greater will be the suction in the carbureter pipe, hence the greater the amount of gasoline drawn in. This will result in too rich a mixture for satisfactory operation. To provide for this, carbureters of the *compensating* type have a by-pass, as shown in Fig. 70. As the throttle-valve is opened wider, the by-pass valve gradually opens also, so that extra air is furnished the mixture, thus diluting it as the engine speeds up, and maintaining it at proper quality for all conditions of running.

Proper Mixture of Gasoline and Air. If the mixture is too weak in gasoline, the running will be affected. Explosions will be missed. If the mixture is too strong, the engine will fail to speed up. The action will be sluggish. It will not pull.

If the mixture is too rich, one can tell it from the presence of explosions in the muffler; from the very dense smoke, which is black; and from the sluggish action of the engine. Smoke caused by too

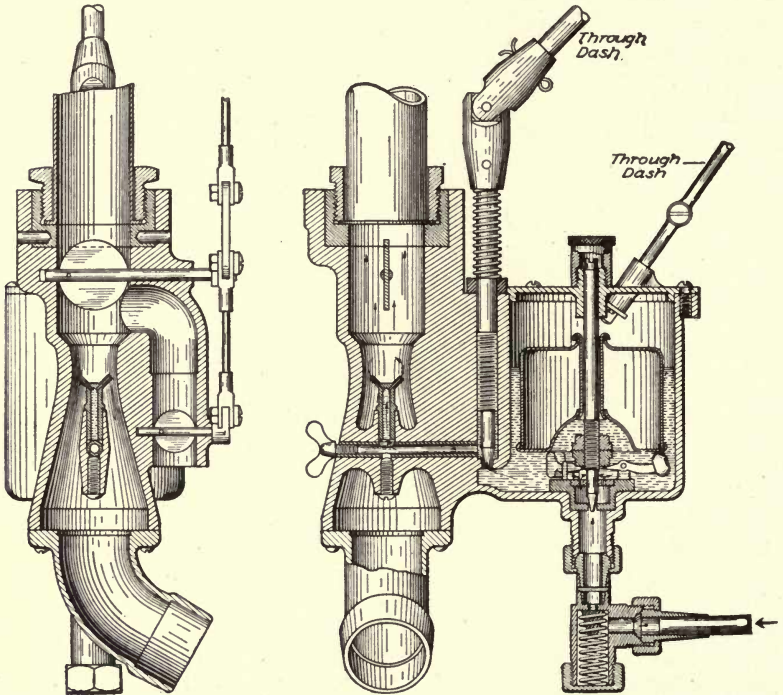

Fig. 70. Carburetor of Compensating Type, Admitting Increased Supply of Air as Speed of Engine Increases.
H. H. Franklin Manufacturing Company, Syracuse, N. Y.

much oil is blue, entirely different from the smoke caused by too much gasoline.

In the case of a weak mixture, if it fires at all, it will make a pop in the carburetor, caused by the fact that a weak mixture will light readily in open air, but will not light well under compression. Popping back in the carburetor is caused by late spark or weak mixture. An engine with a very high compression will require a richer mixture than one having less compression.

Textbooks on gasoline engines usually make the statement that gasoline will ignite in a range of mixtures varying from one part by weight of gasoline to eight of air, up to as weak a mixture as one of gasoline to sixteen of air. However, there is no gauge about the automobile or carbureter by which one can gauge the relative weight. The only way to determine what is a proper mixture is by observing closely the action of the engine, supplying sufficient gasoline until indications of a rich mixture show themselves, as indicated above. Then slightly diminish the gasoline, until the condition of best running is secured.

DIRECTIONS FOR CONNECTING AND ADJUSTING A CARBURETER TO A MOTOR

1. Connect to the intake pipe on motor, as close to inlet valve as convenient, provided the motor does not overheat. The carbureter should not be placed where it will get hot, as this would change the quality of the mixture; but the closer you connect the carbureter to the inlet valve, the quicker the motor will respond to the throttle.

2. Great caution should be used to avoid traps or pockets of any description in pipe between carbureter and motor, or at low speed the fuel will condense and settle in such traps, and when the throttle is open for high speed the increased velocity of air through pipe will pick up this accumulation of fuel and cause smoke and trouble until pipe is clean.

3. Connect gasoline fuel to float-cup, with head enough to fill the cup. It is best to use brass pipe and fittings for gasoline, if convenient, as iron pipe is liable to rust and scale, which may clog inlet valve to carbureter and cause trouble.

4. Arrangements should be made to filter or strain all gasoline when filling tank, as it is very sure to contain some dirt or foreign substance collected from cans and barrels in handling.

5. When float-chamber is filled, screw needle-point down to seat; set the throttle very nearly closed for low speed; open needle about one-eighth of a turn; then try the motor with igniter in good working condition. When the motor starts, change the adjusting screw until you get a perfect mixture at low speed and no smoke (be sure you have it right at low speed); then lock adjusting screw in position with clamp.

6. Open the throttle by lever, and the motor will speed up under the proper mixture. Throttle may now be opened or closed at will, and no further adjustment will be required, except perhaps for a change of fuel.

7. Do not try to start your motor with the throttle wide open when you have an adjustment for low speed; but start it with throttle closed for low speed, which you can do very easily, as you can turn it at about the slow-running speed yourself, while, if you were to start with the throttle wide open, it might be necessary to flush the carbureter in order to get the fuel rich enough to start with at the speed you would be able to turn it over. This is why

nearly all float-feed carbureters have to be flushed for starting; they have no slow-speed adjustment.

8. On a motor controlled by throttle, the spring on the exhaust valve should be made stronger than is necessary with a motor drawing a full charge at all times; otherwise the partial vacuum created in the cylinder at low speed, owing to the light charge admitted, may unseat the exhaust valve and dilute the charge.

Sometimes water gets into the carbureter, and its contents must then be emptied. This is a point worth remembering in starting a car that has been standing in a heavy rain.

Sometimes the float will stick in the carbureter, and then needs to be cleaned.

A carbureter should be used that has a drain-cock for taking out water.

It is very advantageous to have hot air for the air-intake. This is provided for by having the air-intake pipe end in a wide-flared mouthpiece close to the hot exhaust pipe of the engine.

Leaky Float-Valves. There is neither sense nor profit in neglecting to keep the float-valve of the carbureter tight. The effect of a leaky valve may not be very marked in cold weather as regards the quality of the mixture; but in warm weather, when the gasoline evaporates more readily, the leaking may make the mixture so rich as to make it impossible to start the motor unless the gasoline is turned off at the tank immediately on stopping. The best thing with which to grind-in the float-valve is pumice-stone. Emery is too hard, and it imbeds itself in the stem or seat of the valve, making trouble later on.

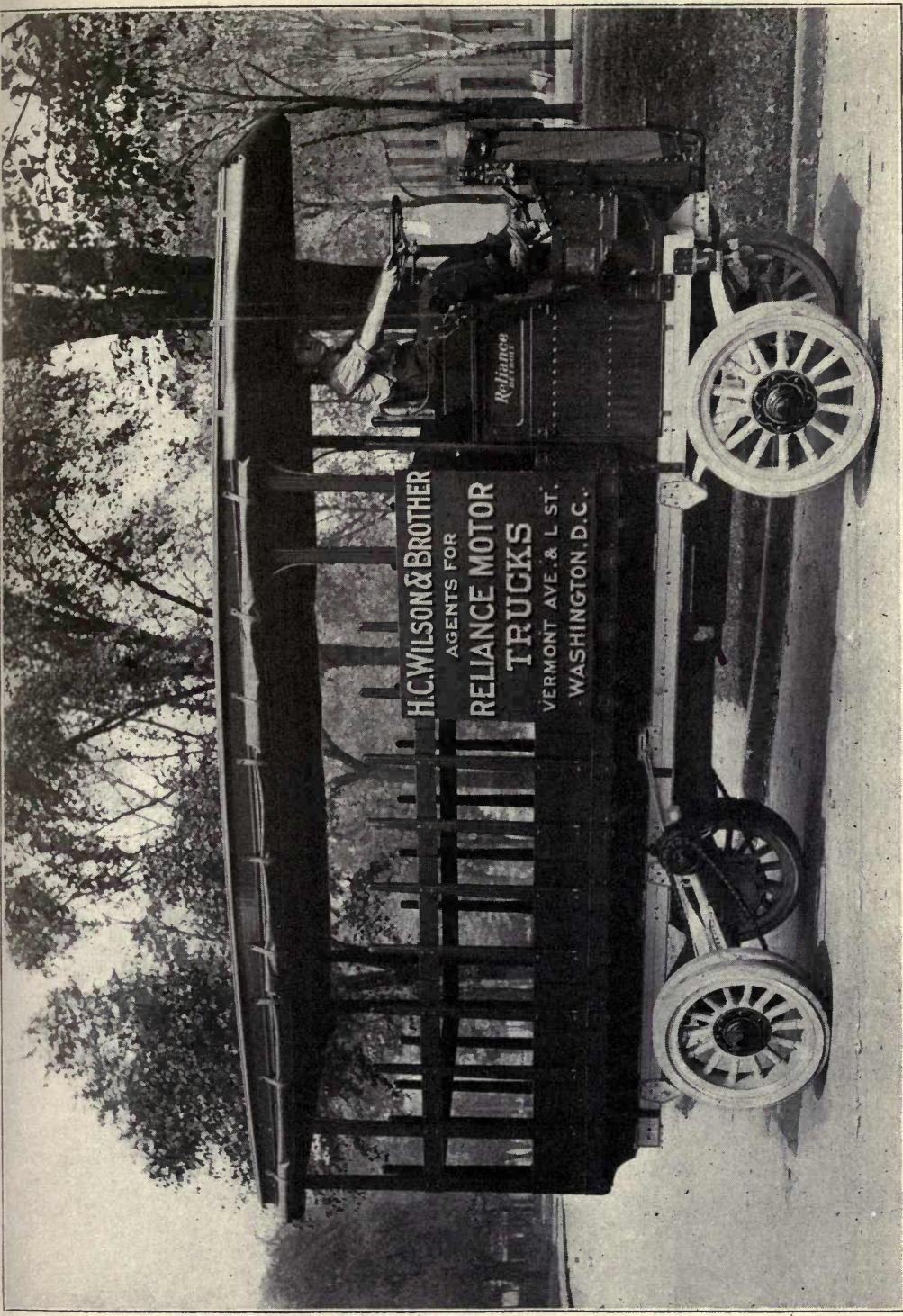

H.C. WILSON & BROTHER
AGENTS FOR
RELIANCE MOTOR TRUCKS
VERMONT AVE. & L ST.
WASHINGTON, D.C.

Reliance

HEAVY-SERVICE MOTOR DELIVERY TRUCK.
Dodge Motor Company, Detroit, Mich.

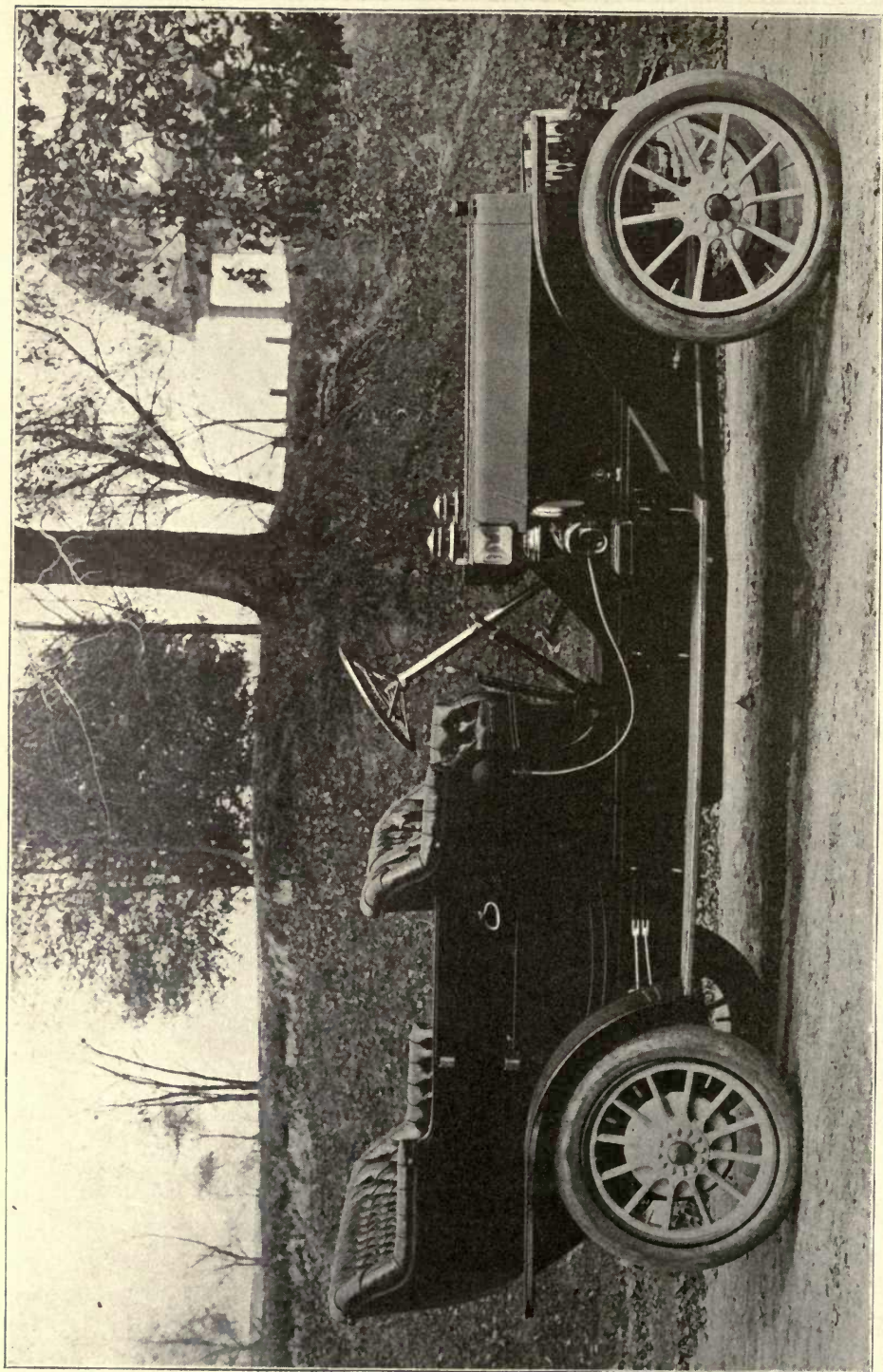

SIX-CYLINDER TOURING CAR, TYPE 45, 1909.
Premier Motor Manufacturing Company, Indianapolis, Ind.

AUTOMOBILES

PART II

IGNITION SYSTEMS

As the result of many years of experimenting with various systems of ignition of the explosive vapor in gas engines, the following conclusions have been definitely reached:

A single spark is not reliable enough to be depended on. The explosive mixture sometimes fails to ignite from the first spark, and the ignition spreads slowly. Hence the aim of the most reliable devices on the market is to produce a series of very rapidly recurring fat sparks of high electromotive force, continuing through a period of time representing from five to ten degrees angular rotation of the fly-wheel, with devices for changing the period of sparking time so that it occurs earlier or later in the mechanical cycle of the engine—that is, earlier or later in the stroke. (Really the igniting period is usually at the end of the compression stroke, with adjustment making it possible to transfer part or all of it past the dead center or a little after the beginning of the pressure or explosion stroke).

DRY-CELL AND JUMP-SPARK SYSTEM OF IGNITION

The simplest ignition system, and the one in general use on light runabouts, is the *Dry-Cell and Jump-Spark System*. A diagram of this system is shown in Fig. 71, which shows the ignition system of the Cadillac single-cylinder automobile.

In the center of the diagram are shown two sets or batteries of dry cells, *aaaa* and *bbbb*. Two sets of dry cells are used, simply so that if one set grows weak the other set may be put into service. Care must be taken in re-wiring to see that the current flows in the same direction in each battery. This can be determined by tracing the direction in which the current should flow. Taking for instance the diagram, when the switch *F* is closed in either direction, it completes an electrical circuit between one terminal of either battery and the metal frame of the car, as terminal *F* of the switch is electrically connected by a wire to the metal frame of the car. The commutator *P* has also one terminal electrically connected to the frame of the car. Following the current now, starting at *aaaa*, it flows through

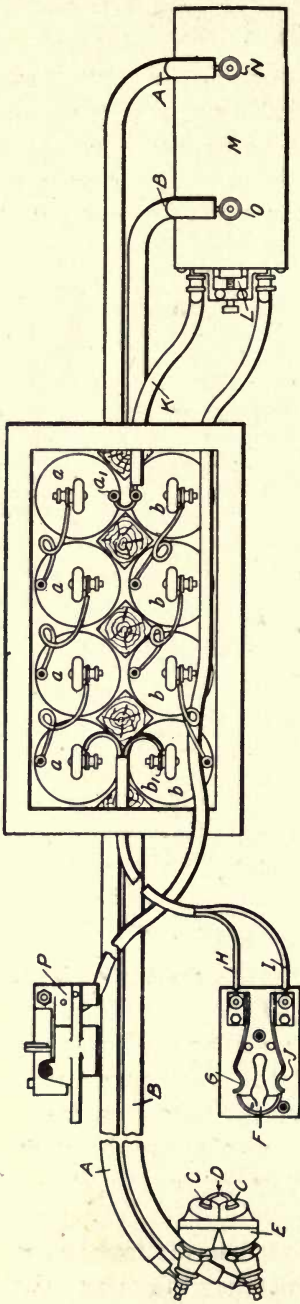

Fig. 71. Connections for Dry-Cell and Jump-Spark Ignition System for Single-Cylinder Engine, Cadillac Motor Car Company, Detroit, Mich.

H, and through the closed blade of the switch *F*; thence through the metal frame of the car to the commutator; and at such time as the metal contact of the commutator is closed, it passes from the commutator through the spark-coil or vibrator, entering at *L* and leaving at *K*. This completes what is known as the *primary circuit*. The reason it is called the primary circuit is that terminals *L* and *K* in the spark-coil are connected to the primary winding of the spark-coil. Wires *A* and *B* complete a circuit between the secondary winding of the spark-coil and the spark-plug *E*.

At *L* on the coil, there is a magnetic circuit maker and breaker, called the *trembler* or *vibrator*, which, when properly adjusted, makes and breaks the circuit through the primary winding of the coil, so long as the primary circuit is complete everywhere else. The action of the vibrator is continuous; that is, if the engine is not in motion and the battery circuit is closed, by closing the switch and bringing the metallic part of the commutator into contact with the circuit, there will be an uninterrupted humming of the coil. As soon as the engine is started, however, the make and break of the commutator, which is mechanically driven by the engine, causes intervals in the period of

humming, which then takes place only during the ignition period.

The interrupted flow through the primary circuit, and through the primary coil of the spark-coil, causes an induced electrical current to pass through the secondary winding of the coil. This secondary winding is of much finer wire than the primary, and has a great many more turns. The result is that the induced electromotive force in the secondary coil is as many times higher than that of the primary as the ratio between the number of turns of wire on the coils. Every time there is a break in the primary circuit due to the action of the trembler in that circuit, an induced electromotive force of high pressure is set up in the secondary-coil system. This secondary electromotive force is so powerful that a small gap may be left in the secondary circuit and still the electric current will pulsate through the secondary winding, causing a spark to occur at the break. The wires of the secondary circuit must be thoroughly and heavily insulated, as they convey an electromotive force of several thousand volts pressure. The small gap above referred to is placed inside the cylinder, and is contained in the spark-plug.

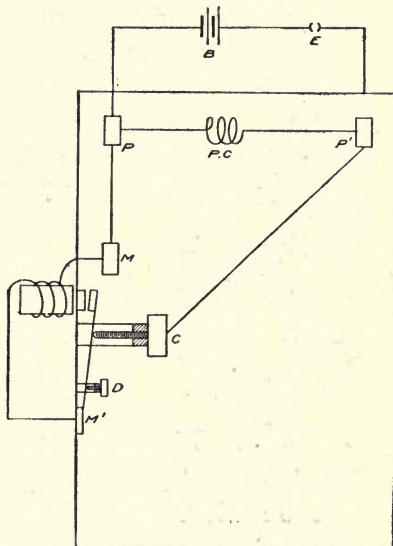

Fig. 72. Diagram Showing Action of Vibrator or Trembler.

Action of Vibrator. Fig. 72 is a diagram explaining the action of the vibrator or trembler—namely, the humming part of the spark-coil. *P* is one terminal of the primary circuit. From *P* a shunted circuit leads to the magnet terminal *M*, around the magnet, to the other magnet terminal *M'*; thence through the armature spring to the contact-screw *C*, which is connected to the other post *P'* of the primary-coil circuit. The regular primary circuit through the primary coil is indicated by *P C*.

As soon as the primary circuit is closed by the commutator *E*, the magnet in the circuit *MM'* becomes magnetized, drawing down

the soft iron piece fastened to the spring, which has also served as a conductor between *D* and *C*. As soon as the spring is drawn down, the circuit through the magnet is broken; and the magnet being demagnetized, the mechanical return action of the spring draws it back again. As soon as it has sprung back far enough to touch the point of the contact-screw *C*, the original action is repeated. It will be noted, therefore, that the rapidity of action of the make-and-break mechanism depends on the adjustment of the spring and contact-screw.

Adjustment of Spark-Coil. The faulty adjustment of a spark-coil is apt to cause a great deal of trouble. Among the troubles which may be caused are: *Short life of batteries, burned contacts of the coil, and poor running of the engine.* The color of the spark at the length of $\frac{1}{16}$ inch should be a bluish purple. With an accurate adjustment, this characteristic color will be in evidence. In making adjustments, remove first the vibrator contact-screw *C*. Then adjust the vibrator spring so that the hammer or piece of iron on the end of this spring stands normally about $\frac{1}{16}$ inch from the end of the coil. Then insert the contact-screw *C*, and screw it in until it just touches the platinum contact on the vibrator spring. Be sure that it touches



Fig. 73. Dash Coil for One-Cylinder Engine. Cover Removed. The Splitdorf Laboratory, New York City.

only very lightly. Screw down the spring-adjusting screw *D* until, when the circuit is closed, the vibrator rings with a high-pitch tone. Then start the engine. Then gradually release the spring-adjusting screw and contact-screw until that cylinder begins to miss fire. Then tighten up both screws just a trifle at a time, until the engine will run without missing explosions.

It is common practice to adjust vibrators so that the spring gives a high, clear tone, and to draw the longest possible spark. This practice is extremely wasteful of battery force; and since it increases the tension of the current passing through the vibrators, the platinum contacts wear out rapidly, causing them to stick and the engine to miss fire. A happy medium can be learned by careful observation while adjusting the screws.

Figs. 73, 74, and 75 illustrate typical spark-coils. - Fig. 73 shows a Splitdorf dash coil for a one-cylinder engine, the cover being removed; Fig. 74 shows a dash coil of the same make for a two-cylinder engine, one of the units being removed from case; and Fig. 75 shows a Splitdorf three-cylinder dash coil, also with cover removed.

Fig. 76 shows the principles involved in the wiring of a typical two-cylinder engine using dry-cell and spark-coil ignition. *A* and *B* are two batteries, each consisting of three cells. The three cells of each group are connected in series. *C* is the *spark timer* or *commutator*, which is controlled by the spark-lever

so that the sparking may be made to occur earlier or later during the stroke of the piston. The shaft shown at *D* on the diagram is really the shaft *E*. Since the commutator is actually attached to the motor, it is shown separately in the diagram for clearness in showing the wiring connections. *F* is grounded to the motor frame, while *G* and *H* are both insulated

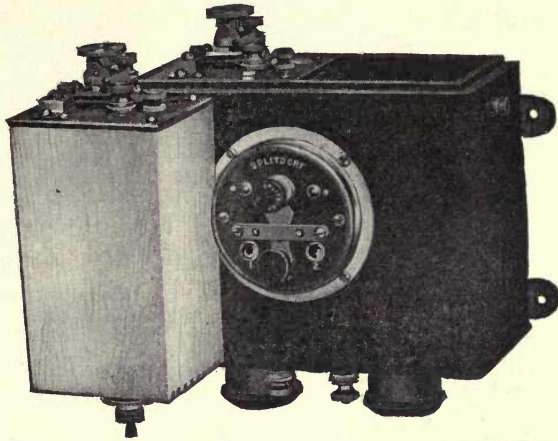

Fig. 74. Dash Coil for Two-Cylinder Engine. Cover Removed.
Also note removable unit.
The Splitdorf Laboratory, New York City.

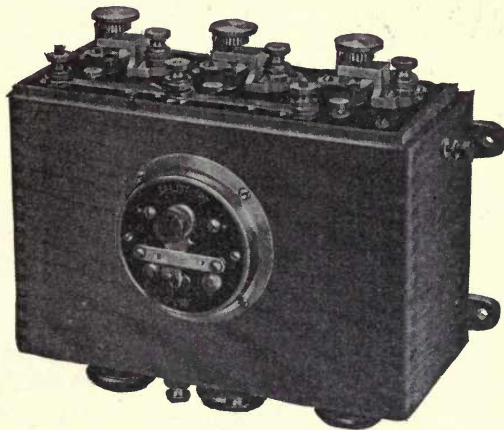

Fig. 75. Dash Coil for Three-Cylinder Engine.
The Splitdorf Laboratory, New York City.

from the motor frame. By the rotation of shaft *D*, which carries the commutator, the current is first permitted to flow between *F* and *G* when these two terminals are brought into contact by friction with the metallic periphery of the commutator. As the commutator continues to revolve, the fiber portion of the periphery advances between *F* and *G*, breaking the circuit between those two terminals.

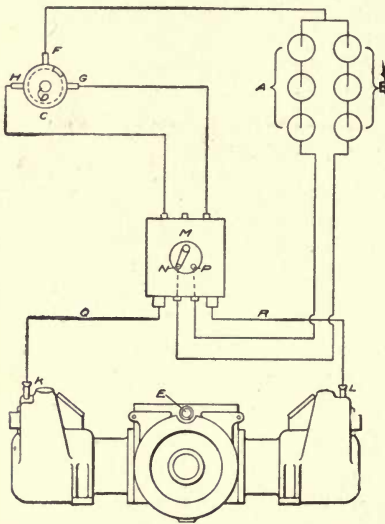

Fig. 76. Wiring Diagram for Two-Cylinder Engine Using Dry-Cell and Spark-Coil System for Ignition.

Meanwhile metallic circuit has been established between *F* and *H*. From these points current flows through the spark-coil, and sparks are caused alternately in the spark-plugs *K* and *L*. The switch key *N* shown in the center of the diagram is located on the dash. It will be seen by the connections, that either one or the other battery of dry cells may be connected at will. When the switch key is in the position shown, the battery *B* is in use; and when the switch key is over *P*, the battery *A* is in use.

When it is desired to leave the car, or to use the engine compression as a brake, the switch key is either removed or placed in the middle or neutral position, and the electrical circuit is broken, so that no spark will occur, and hence the motor cannot be started until the key is replaced.

Wires *Q* and *R* connect the spark-plugs to the secondary or high-tension winding of the spark-coil, and are heavily insulated.

Fig. 77 is a wiring diagram for a four-cylinder engine, which is provided not only with dry cells but also with a storage battery. Otherwise the connections and operation are like the systems already explained for one-cylinder and two-cylinder engines respectively.

DIRECT-CURRENT SHUNT-WOUND DYNAMO SYSTEM

Dynamos for Charging Batteries for Ignition. For the purpose of utilizing the power of the gasoline engine to charge the storage

batteries used for ignition, there are several makes of direct-current dynamos on the market. These dynamos are driven either by a belt from some moving shaft; or by a gear mounted on the commutator shaft of the gasoline engine, meshing with a gear on the armature shaft of the little dynamo; or by meshing of the gear on the dynamo shaft with teeth cut into the engine fly-wheel. The connection should never be made by the use of thin gear rings screwed onto the engine fly-wheel, as the centrifugal force when the engine races for even a few revolutions is apt to burst the gear rims at the thin part.

As the speed of any shaft driven by the gasoline engine will be variable, such dynamos require governors to regulate their armature speed so that it will be kept constant no matter what the speed of the driving shaft is.

All dynamos have a certain speed at which they generate their normal voltage and current. This speed cannot be exceeded without danger of burning up the insulation of the machine by its own excessive current, or damaging its running parts. Moreover, an increased voltage is very damaging to the entire ignition system, particularly the storage-battery cells; hence it is very important that a small voltmeter be connected in the circuit at all times when a charging dynamo is on the car, and that this voltmeter be kept in sight so that any faulty action of the speed governor of the little dynamo may be at once detected.

This system also requires a means of automatically disconnecting the dynamo from the battery as soon as the engine stops, so as to prevent the battery current running back through the dynamo. The current for ignition is taken from the storage battery at all times. Fig. 78 shows the connections for this system.

Fig. 79 shows a shunt-wound dynamo with its speed governor.

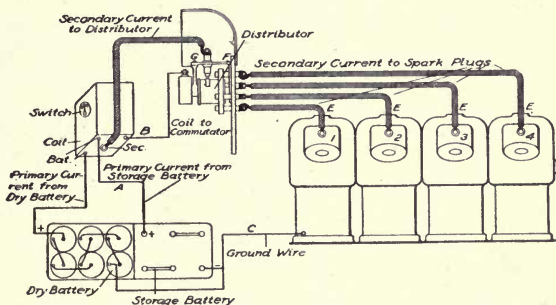

Fig. 77. Wiring Diagram for Four-Cylinder Engine Using Spark-Coil in Connection with Dry Cells and Storage Battery for Ignition.

MAGNETO SYSTEMS

The most troublesome features of the shunt-wound constant-current dynamo are speed regulation and constant attention to proper

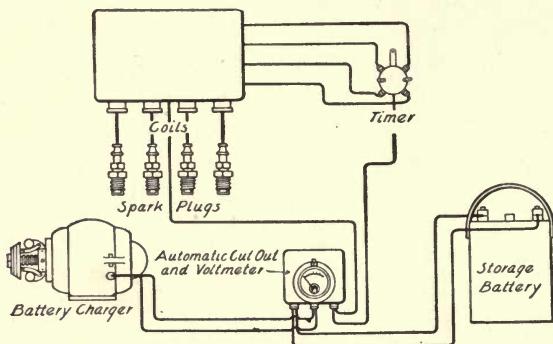

Fig. 78. Connections for Direct-Current Shunt-Wound Dynamo System of Ignition and Charging Storage Battery.

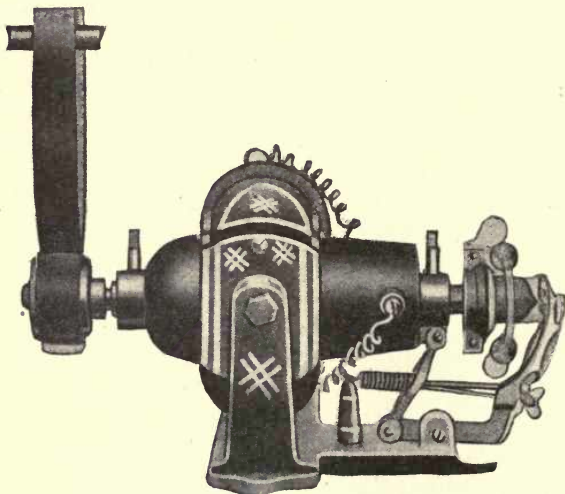

Fig. 79. Direct-Current Shunt-Wound Dynamo Driven by Gasoline Engine in Car and Used for Charging Storage Battery.

voltage. Hence there has been a tendency to dispense with charging the storage battery while running—which is the real advantage of the shunt-wound dynamo—and to use instead a *magneto*. The magneto cannot be used for charging batteries, owing to the irregularity of its uncommutated or very roughly commutated electromotive force. The magneto may be either alternating-current or direct-current. In the latter case, there is no attempt as a rule at more than one commutation, for the reason that it is de-

sired to have the *peak* of the electromotive wave curve occur regularly in unison with the engine speed, that is, the impulses generated by the magneto must be made to coincide with the times at which the sparking must take place. This is accomplished by gearing the magneto to the engine cam-shaft.

As above stated, the magneto cannot be used for charging storage batteries or for furnishing current for electric lights, both of which can be accomplished with the shunt-wound dynamo system. The only purpose for which the magneto can be used is for the ignition of the charge in the engine cylinders; and it is satisfactory for this purpose only when the engine is running at full speed. Hence an auxiliary battery and spark-coil system must be used for starting or at very slow speed of the engine. The magneto is a dynamo which can be built much more cheaply than a shunt-wound dynamo with speed governor, and can be built so small that it takes up much less room.

The simplest magneto system is one which uses the same spark-coil for magneto and batteries. Fig. 80 shows the connections for this system.

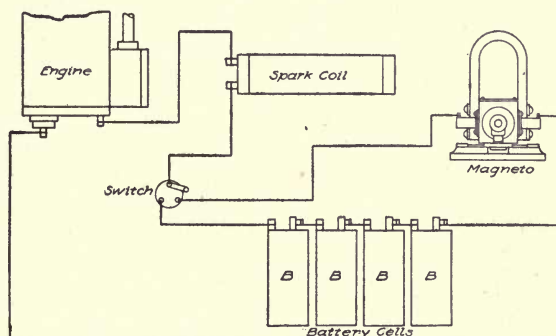

Fig. 80. Connections for Magneto System of Ignition. Magneto Current or Battery Current Using Same Spark-Coil.

A high-tension or high-voltage magneto will generate a spark of sufficient intensity to ignite the charge at the spark-coil. The tendency however is to use a low-tension magneto and an independent spark-coil without trembler, for ignition at regular running speed of the engine; and a battery and spark-coil with trembler for starting and emergency. This method provides at all times two independent ignition systems, and preserves the spark-coil with trembler so that it has a longer life than when it is used all the time.

Fig. 81 is a diagram of this system as used by the National Motor Vehicle Company. The magneto has its own distributor or commutator attached to it; a magneto coil is placed in the same box as the storage battery; 1, 2, 3, and 4 are the lines to the spark-plugs in the four engine cylinders.

One pole of the magneto is grounded to the frame; and the other terminal comes out at the rear of the magneto on a copper brush, and

is led by a cable through the switch on the dash (when thrown to the right), to the primary winding of the magneto coil, and from there through the circuit-breaker on front of magneto to ground on the frame, thus completing the primary or low-tension circuit of the magneto. The high-tension current goes from the secondary winding in the coil into the distributor on the magneto, whence it is distributed to the four spark-plugs.

The second system, which is the one for emergency and for starting the engine, consists of a three-cell six-volt storage battery;

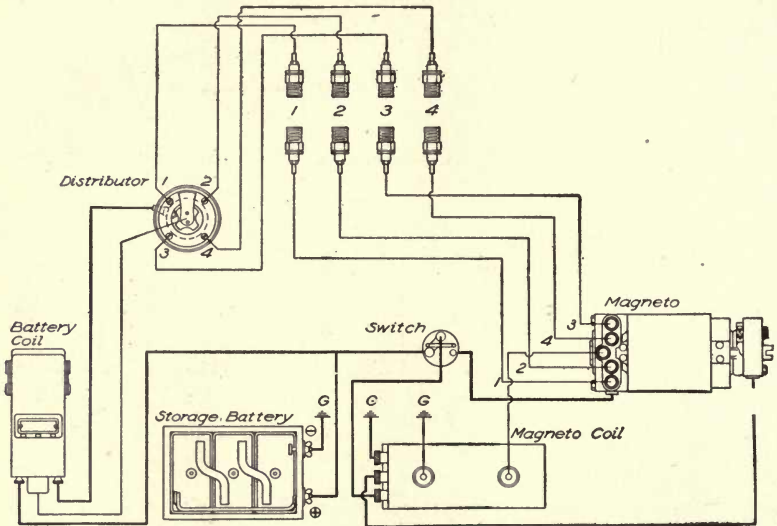
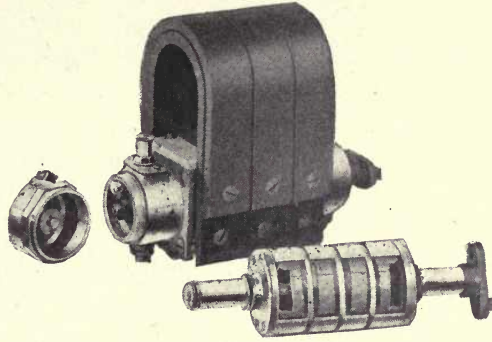

Fig. 81. Magneto, Spark-Coil, and Storage-Battery System of Ignition.
National Motor Vehicle Company, Indianapolis, Ind.

a single vibrator coil; a distributor or commutator, located on the vertical shaft at rear of engine; and the set of spark-plugs. In this system the current goes from the positive terminal of the battery (the negative terminal being grounded to the frame), through the primary winding and vibrator of the coil on dash, and from there through the circuit-breaker located in the bottom of the distributor, and thence to ground on engine. The high-tension current comes from the secondary winding of the battery coil to the distributor, whence it is distributed to the four spark-plugs. Each system has its own set of spark-plugs. To operate this system, the plug must be placed in the left hole in the battery coil. The

same spark-lever controls the action of both systems. Ignition responds more instantaneously with the magneto system, so that it will appear to be timed ahead of the battery system.

The principal precaution to be observed in connection with the magneto, is to take care to prevent spattering of water on it when the car is being washed, to oil it carefully and regularly, and to see that none of its fastening screws become loose. Care should be taken to see that all wiring connections are tight, and that distributors are kept clean. Magneto brushes must not be flooded with oil, as they will become gummy and cause irregular firing.



Magneto of Locomobile Car. Armature Shown at Right, Withdrawn from Magneto. Bronze Cap at Left Encloses Contact End of Magneto.

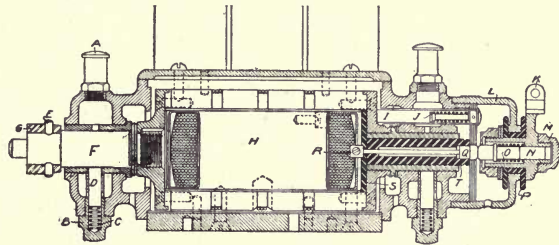

Sectional View of Magneto (Magnets Only Partly Shown).
 Fig. 82. Magneto and Parts as Used in Locomobile Car. A—Oiler; B—Bearing Oiler; C—Bearing Oiler Spring; D—Bearing Oiler Wick; E—Taper Pin Holding Coupling on Armature Shaft; F—Armature Shaft; G—Driving-Shaft Coupling; H—Armature; I—Brush; J—Brush Spring; K—Magneto Terminal; L—Bearing Cap; M—Contact Plunger Socket Cap; N—Contact Plunger; O—Plunger Spring; P—Bearing Cap Insulating Bushing; Q—Armature Contact Stud; R—Armature Terminal; S—Armature Flange Insulation Plate; T—Armature Shaft Insulation Bushing.

Locomobile Company of America, Bridgeport, Conn.

Fig. 82 shows in detail a typical magneto and its parts, as used in the Locomobile.

SPARK-PLUGS

The *spark-plug* consists simply of a receptacle for the purpose of bringing closely together the two exposed parts in the secondary line of the spark-coil, across which exposed parts it is proposed to have the spark take place. Inasmuch as the voltage, as already explained, is very high, the chief qualification of the spark-plug is that it must

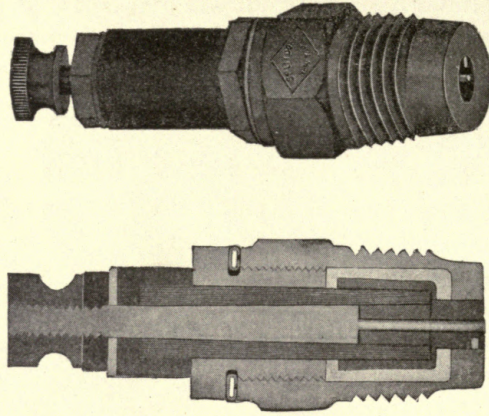

Fig. 83. Splitdorf Mica Spark-Plug.
The Splitdorf Laboratory, New York City.

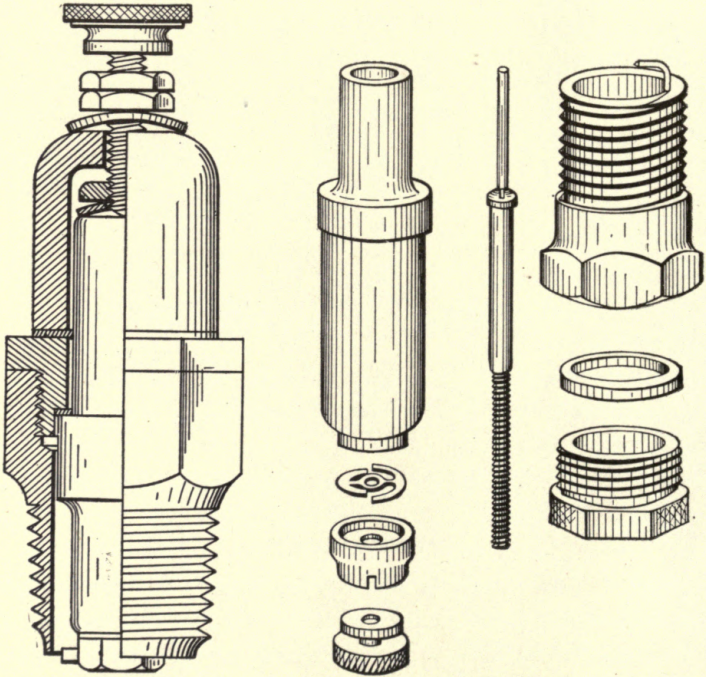

Fig. 84. Section of Sta-Rite
Spark-Plug.
R. E. Hardy Company, New York, N. Y.

Fig. 85. Component Parts of a Soot-Proof
Spark-Plug.
A. Mezgar, Brooklyn, N. Y.

have high insulating qualities so that the only possible path for the current will be across the gap. This means that the plug must be made of high-grade porcelain, and that the mica used in its insulation should be of the highest quality obtainable. The points should be platinum.

Fig. 83 gives an external and a sectional view of the Splitdorf mica spark-plug, made by the Splitdorf Laboratory, New York. Fig. 84 is a sectional view of a double porcelain separable plug, the Sta-Rite, made by the R. E. Hardy Company, New York. Fig. 85 shows all parts of the soot-proof plug made by A. Mezgar, Brooklyn, N. Y. The peculiar construction of the air-passages in this plug are such that it is claimed the plug may be blackened by holding it in the flame of a candle before placing in the cylinder, and after some use the blast in the cylinder will have cleaned off the soot.

Fig. 86 shows the standard dimensions for spark-plugs as adopted by the Association of Licensed Automobile Manufacturers.

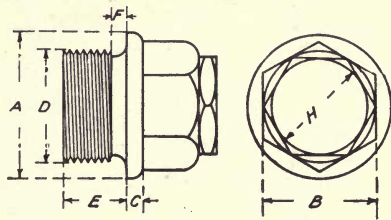

Fig. 86. Design and Dimensions of Standard Spark-Plug, Association of Licensed Automobile Manufacturers.
 A—1½ in.; B—¾ in.; C—¼ in.; D—¾ in.; E—Minimum, ½ in.; E'—Maximum, ⅙ in.; H—¾ in.

It is always well to have an extra set of spark-plugs in the toolbox.

MAKE-AND-BREAK SYSTEM

The *Make-and-Break* system of ignition, which is the most prevalent in stationary gas-engine work, has recently come into favor in automobile practice. Fig 87 shows this system as used in the Studebaker car. In the make-and-break system, instead of using a spark-plug to provide the gap across which the spark jumps when high tension occurs in the secondary system as already explained, a rotating piece and spring are employed, these two pieces being in wiping contact during part of the time, and the contact being broken during a certain part of the time, owing to the shape of the rotating piece (which is clearly shown in the figure). The figure shows also the relative positions of the four make-and-break igniters at any one moment in a four-cylinder engine. The springs at the top of the igniters occasionally lose their tension, and may have to be replaced

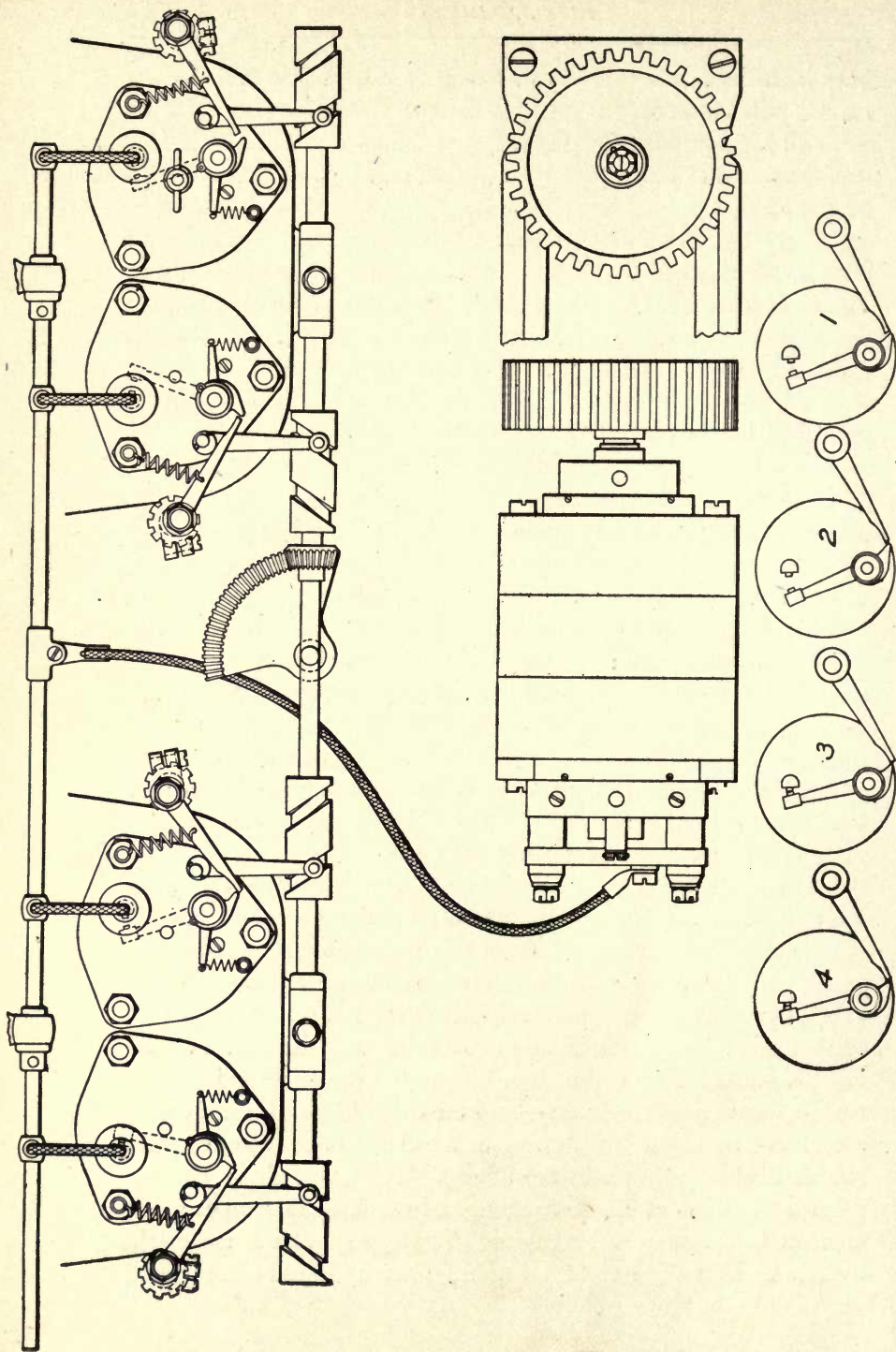

Fig. 87. Make-and-Break Ignition System as Used in Studebaker Four-Cylinder Car. Upper diagram shows but one igniter in contact, which is correct. Lower diagram shows igniters 3 and 4 short-circuited. Studebaker Brothers Manufacturing Company, South Bend, Ind.

or adjusted by turning the tension collar one or more holes and re-inserting the cotter-pin.

After a month or so of continuous running, the contact-points at the bottom of the igniter and on the inside of the cylinder may become blackened. In this case it is advisable to remove the entire igniter-block, and soak it for ten or fifteen minutes in kerosene, after which it should be washed thoroughly. When replacing the block in the cylinder, always see that the external parts are carefully lubricated. It is well to remove the contact-blocks about once a month, and wash them as above described.

STORAGE BATTERIES FOR IGNITION PURPOSES WITH GASOLINE ENGINES

The most satisfactory current for charging storage batteries for ignition in gasoline engines, is one which can be supplied at a low voltage, as by means of dynamos specially designed for this purpose, so that it can be regulated at about the total voltage of the batteries to be charged—that is, in the neighborhood of six to eight volts.

To charge the batteries, it is necessary to raise the voltage of the dynamo to a greater value than that of the battery. If the voltage of the charging dynamo is less than that of the battery, the ammeter will indicate that a current is flowing, but the pointer will be drawn towards the left or in a backward direction, showing that the current is in an opposite direction from what it should be, and the battery is discharging through the dynamo.

If it is not practicable to secure the power by driving a low-voltage dynamo for charging the storage battery, it will be necessary to place some kind of a variable electrical resistance in the charging circuit, so as to prevent a destructive current from flowing, due to the higher voltage. For this purpose, incandescent lamps may be used, placed in the circuit in accordance with the diagrams, Fig. 88. The necessary number and capacity of the lamps depend on the voltage supplied and the current required. The diagrams indicate 16-candle-power lamps; with 32-candle-power lamps, twice as much current would flow through the batteries.

Sketch *A* shows a voltage of 110, each lamp used allowing one half-ampere to flow. Two lamps would mean one ampere; six lamps, three amperes; etc.

Sketches *B* and *C* are for 220 volts. Sketch *B* shows two 20-volt lamps, each allowing one quarter-ampere to flow. Sketch *C* shows 110-volt lamps with a line voltage of 220. In this sketch the lamps are connected in pairs, each pair taking one half-ampere.

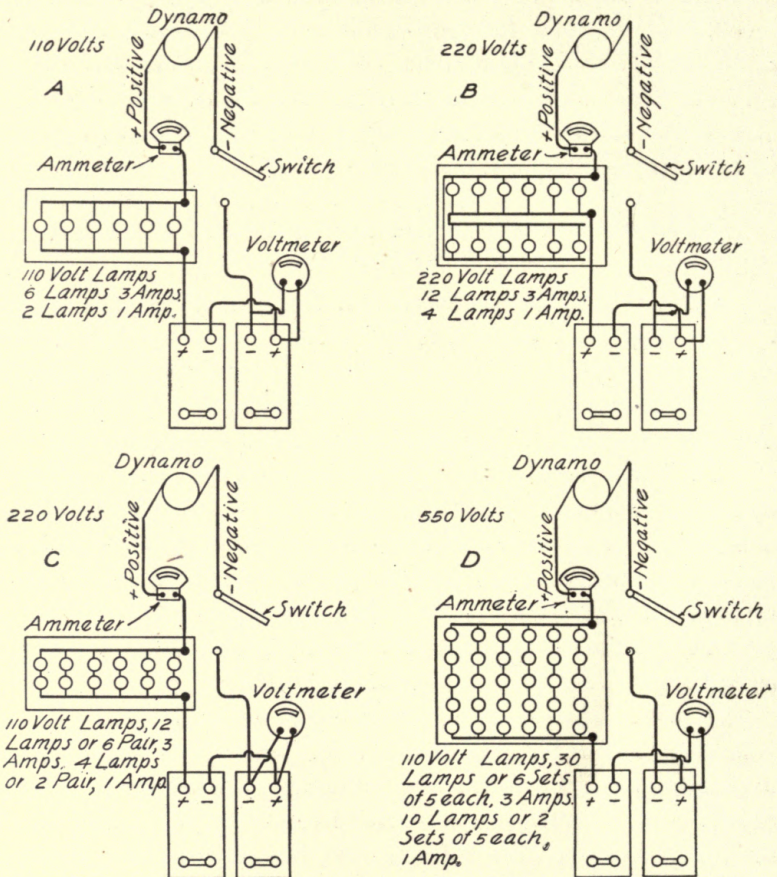

Fig. 88. Diagrams Showing Use of Incandescent Lamps as Variable Resistances in Charging Storage Batteries Used for Ignition Purposes with Gasoline Engines.

Sketch *D* shows connections for 550 volts. In this case five times as many lamps are needed as in *A*, connected in sets of five each, each set giving one half-ampere.

Only direct current can be used in charging storage batteries. *Be sure to connect the positive wire of the charging line with the positive terminal of the battery.* Otherwise, damage to the battery will result.

To determine which is the positive terminal of the charging line, attach a piece of lead to each wire of the line, and immerse the lead pieces in a glass containing diluted sulphuric acid, without touching each other. After the current has passed through the acid for a short time, the positive lead will commence to discolor and, after a while, will turn brown. Mark this wire plus (+), and connect it to the battery terminal marked plus (+), placing the resistance of lamps or other nature between the positive terminal of the charging line and the positive terminal of the battery. The voltage of the charging line should not be over twenty-five per cent greater than the discharge voltage of the battery—or, for a three-cell six-volt battery, about 7.5 volts. The indication that a battery is fully charged is *gasing* or fine boiling of the liquid electrolyte. Further instructions as to care of the storage battery will be found below, under the headings "Care and Operation of Electric Vehicles" and "Care of Storage Batteries."

ENGINE-CONTROLLING MECHANISM

Before attempting to drive the car, the new operator should become acquainted with the functions of the various levers and pedals. Of these, the ones that control the engine are the *Spark-Lever* and the *Throttle-Lever* or *Pedal*; also the *Compression-Release Pedal* and *Muffler Cut-Out*.

Spark-Lever. The spark-lever controls the time at which the electric spark occurs in the cylinders. Without a spark, there can be no ignition of gas in the cylinders, and no movement of the engine. The time at which the spark occurs is an important feature which is made use of in regulating the speed and power of the engine. The spark-lever is usually so placed that by moving it back toward the operator as far as it will go, it causes the spark to occur at a late period in the stroke; that is, the piston will have passed a considerable distance from the beginning of its stroke, and the crank a considerable angle past the dead center, when the charge is ignited. This action is called *retarding the spark*.

One effect of this late spark is to prevent any back-kicking, which would likely occur if the explosion took place near the dead center in an engine which had not yet attained any forward momentum.

Another effect is weak power and consequently low speed. The compressed charge has had opportunity to expand as it fills the increasing space back of the advancing piston; hence, when it is ignited, the pressure force due to the explosion will not be so great as when the ignited mixture is still more highly compressed. Moreover, the spark occurring late in the stroke means that the effective forward pressure effort is exerted during a lesser portion of the entire stroke than would be the case with an early spark.

Advancing the spark-lever advances the spark; that is, the spark occurs earlier in the stroke, and the speed is accelerated.

In addition to hand-regulation, *automatic regulation* of the spark is accomplished in some cars. The method employed is usually an automatic centrifugal or inertia governor, being in all mechanical respects a miniature steam-engine fly-wheel type of governor, which is mounted on the commutator-shaft and connected to the commutator so as to cause a later or retarded ignition if the speed increases too high. While in one sense such a spark controller is a convenience, it is looked on by many operators as an unnecessary refinement, and merely an additional piece of mechanism to take care of.

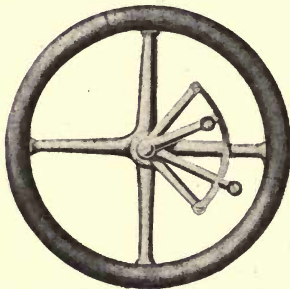

Fig. 89. Hand-Wheel, Showing Usual Location of Spark- and Throttle-Levers.

Location of Spark-Lever. In some cars the spark-lever is on the right of the driver's seat. In other cars it is on the steering column.

Fig. 89 is a view of the top of the hand-wheel, showing the most usual location of spark- and throttle-levers. Fig. 90 shows the steering column in section, and illustrates how the various concentric tubes which turn independently of each other are turned by means of these levers and in turn draw the rods regulating spark and throttle control.

Throttle-Lever. The throttle-lever is equally important with the spark-lever in acting as a governor or controlling lever, in regulating the speed and power of the engine. The throttle-lever is named by some makers the *controlling lever* or the *governor lever*. In some makes of car the throttle-lever is located on top of the steering wheel; in other makes the throttle-lever is operated by a foot-

pedal or button; in still other makes a rod is connected to the throttling valve in such a manner that when the clutch is thrown out, throwing the load off the engine, the same movement closes the throttle, cutting off the supply of gas to the engine till it is just barely

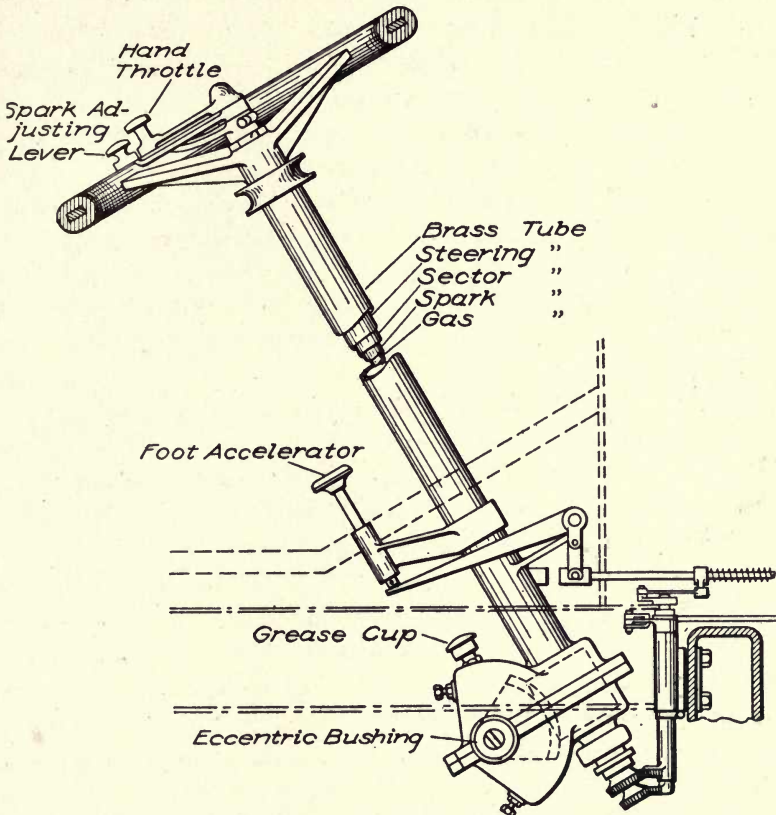

Fig. 90. Section of Steering Column, Showing Spark- and Throttle-Levers and Connections.

enough to keep it turning around. In cars in which such an automatic closing of the throttle is not provided, the operator must throttle his gas supply when he slows up or throws the load off the engine; otherwise the continuance of the full charge of gas into the cylinders will cause the engine to speed up or *race*. This racing is not beneficial to an engine, and must be avoided, either by releasing the foot-pedal which in some cars operates the throttle, or by moving the lever on the steering wheel which controls it in others.

The throttle-
in the pipe-line ru
butterfly valve enl
to engine cylinder
In starting, th

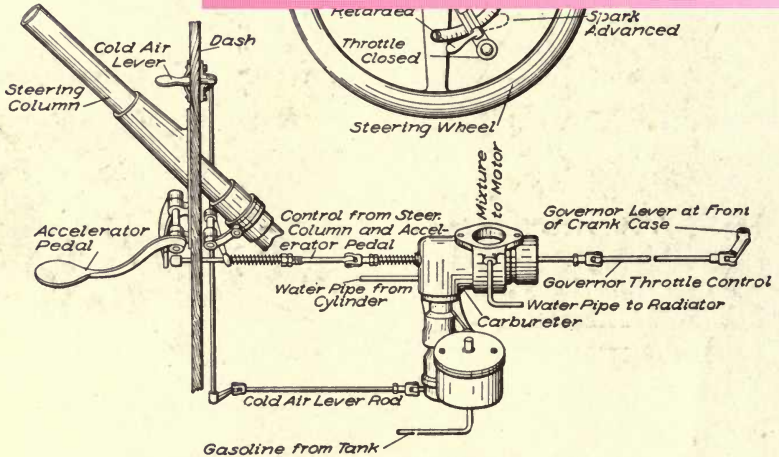

Fig. 91. Throttle-Control System of Peerless Car.
Peerless Motor Car Company, Cleveland, Ohio.

throttle-lever is in the position admitting only enough gas to turn the engine over.

When shifting gears, the throttle should be momentarily closed, and the clutch entirely disengaged.

Just before stopping the engine, push the throttle-lever to the position in which it most completely closes the throttle valve.

In speeding up a car, advance the throttle first, and then follow with the spark.

Do not get in the habit of running the car with the throttle open and spark retarded. This results in over-heating of cylinders and valves, often causing exhaust valves to stick from over-heating and carbonizing, and resulting in excessive gasoline consumption. Keep

the spark advanced in proportion to the speed of the car. However, watch carefully for any signs of knocking, which is occasioned by having the spark too far advanced, causing early explosion of the charge. This throws a heavy strain on the crank-shaft when passing dead center, and is likely to break the crank-shaft.

A novice is inclined to race his engine—to open his throttle too wide, giving too much charge without any load. He is apt to be afraid that if he checks down the throttle, he will have to get out and

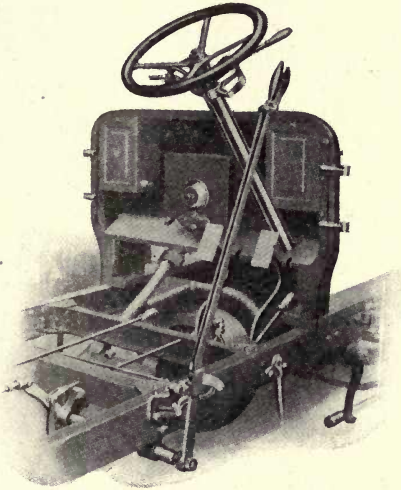

Fig. 92. Steering Column, Control Levers, and Emergency Brake of Great Arrow Car. George N. Pierce Company, Buffalo, N. Y.

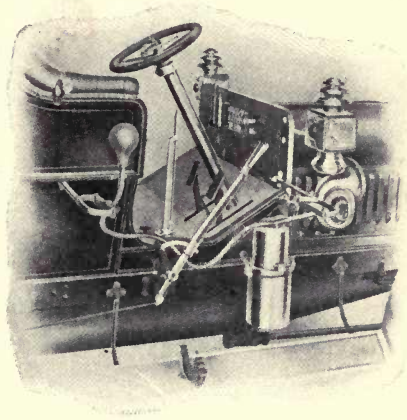

Fig. 93. Steering Column, Control Levers, and Other Operating Devices of Locomobile Car. Locomobile Company of America, Bridgeport, Conn.

start the engine again. The result is that fuel is wasted and parts are worn out unnecessarily.

Fig. 91 is a diagram showing a typical *throttle-control system* as used by the Peerless Motor Car Company. It will be noticed that the small throttle-lever on the steering column, and the *Accelerator* foot-pedal, operate the same rod, regulating the amount of mixture admitted to engine. A separate lever in this car regulates the amount of cold air admitted to the mixture.

Figs. 92 and 93 are other typical examples of engine-controlling mechanism.

Muffler Cut-Out and Compression-Relief Levers. In addition to the spark- and throttle-levers, most cars are provided with levers

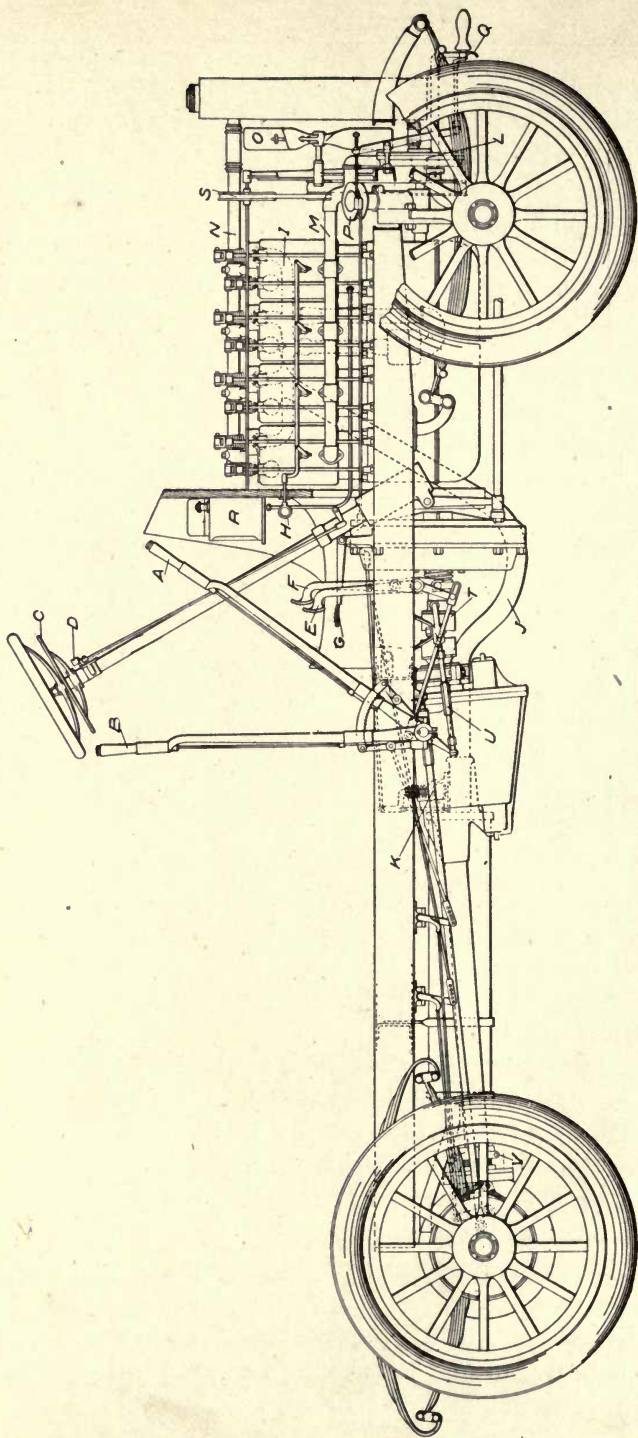

Fig. 94. Side Elevation of Rambler Car, Model 24.

A—Speed-Change Gear Lever; B—Emergency Brake Lever; C—Throttle Ring; D—Spark-Controlling Lever; E—Primary Brake Pedal; F—Clutch Release Pedal; G—Muffler Cut-Out Pedal; H—Pull-Rod for Opening Relief-Cocks; I—Inlet pipe; J—Exhaust Pipe; K—Muffler Cut-Out; L—Circulating Pump; M—Water Pipe from Pump to Cylinder Jackets; N—Water Pipe from Jackets to Radiator; O—Fan; P—Commutator; Q—Safety Crank Latch; R—Oiler; S—Pulley and Driving Rod for Operating Oiler; T—Universal Joint between Clutch and Transmission Gear; U—Gear-Shifting Connections; V—Bearing Adjustment at Rear End of Propeller Shaft.

for opening the exhaust into the air without passing through the muffler. This is a means of gaining more power, and is utilized in going up grades and when power is at low ebb.

The compression-relief rod connects to cocks on the engine cylinders, preventing or partially preventing compression. The chief use of this rod is in starting, to permit of easy cranking. The compression-relief rod, instead of operating independent relief-cocks, is frequently connected to cams or rollers which raise the exhaust valves.

Fig. 94 is a side elevation of Model 24 Rambler Car, which shows very clearly the location and action of the muffler cut-out and compression-relief levers. In this diagram, *G* is the muffler cut-out pedal, which connects to *K*, the muffler cut-out; and *H* is the pull-rod for opening the cylinder compression-relief cocks.

POWER-TRANSMISSION DEVICES

Thus far we have considered the frame, the running gear, the engine, and the methods used for operating and controlling the engine. The next logical step in our analysis of the car into its component parts, is a study of the methods of transmitting the engine power at its various speeds to the running gear. This leads us to a study of *Power-Transmission Systems*.

The power-transmission system consists (1) of the *Clutch* and its operating rods and levers for connecting the engine to the speed-changing or transmission system; (2) of the *Transmission* or *Change-Speed Gears*, which transmit the power of the engine to the *Differential System*, which last-named transmits the power from the change-speed gears to the rear axle of the car. The Clutch System and the Transmission or Change-Speed System each include a set of operating rods and levers, the action of each of which must be thoroughly understood by the operator before he attempts to drive his car.

CLUTCHES

Metallic Constriction-Band Clutches. Most runabouts having horizontal engines use what is known as the *constriction-band* type of clutch in connection with *planetary transmission*. The various speeds are given from the engine to a countershaft or an external hollow shaft carrying a sprocket wheel over which passes a chain

driving a larger sprocket on the rear axle. These various speeds are secured in the following manner:

A series of rods or clutch fingers are attached to a collar on a countershaft in such a manner that they may be operated to and fro by means of a lever located at the driver's right hand, which is known as the *clutch lever*. In this type of transmission, high speed is secured by locking all of the transmission gearing together so that it revolves with the motor shaft and acts as an additional fly-wheel carrying with it the driving sprocket.

In the neutral position, the clutch fingers are altogether released, leaving the motor free to run without driving the automobile.

The constriction bands are used to hold the large ring gears with internal teeth, which constitute the outer periphery, from turning while the internal smaller pinions roll around inside at a speed such that the sprocket is driven at about one-third or one-fourth that of

the engine shaft. The mounting and meshing of the various gears are arranged so that the tightening of one constriction band causes slow speed forward, and of the other constriction band causes slow speed backward. In a good many vehicles of the runabout type, the reverse feature is separately connected to a foot-pedal.

Oil should not be put on metal band clutches unless there is evidence of cutting, as it will cause them to slip. The wearing surfaces of the bands should be wiped with gasoline occasionally, to help keep them smooth and clean.

It is seldom necessary to tighten the clutch bands, and it is usually a mistake to tighten them, as this is likely to cause them to break.

Fig. 95 shows an external view of a typical constriction-band clutch as used with planetary transmission in the Reo car.

Fig. 96 shows the planetary transmission of the Reo car, with

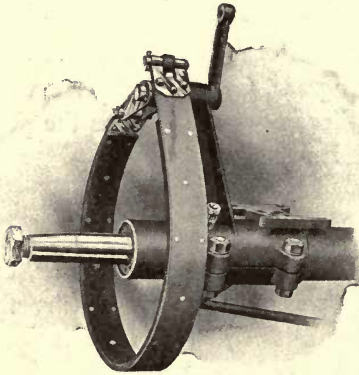

Fig. 95. Constriction-Band Clutch, as Used
in Reo Car.
Reo Motor Car Company, Lansing, Mich.

the rods attached to the clutches. It will be noted that the reversing clutch has its rod connected to a foot-pedal, and the two forward speed clutches are operated by the side lever on the outside of the frame

Planetary transmissions have the clutches and their levers so arranged as to give two speeds forward and one reverse, in almost all instances.

The arrangement of the gears and their action in the planetary

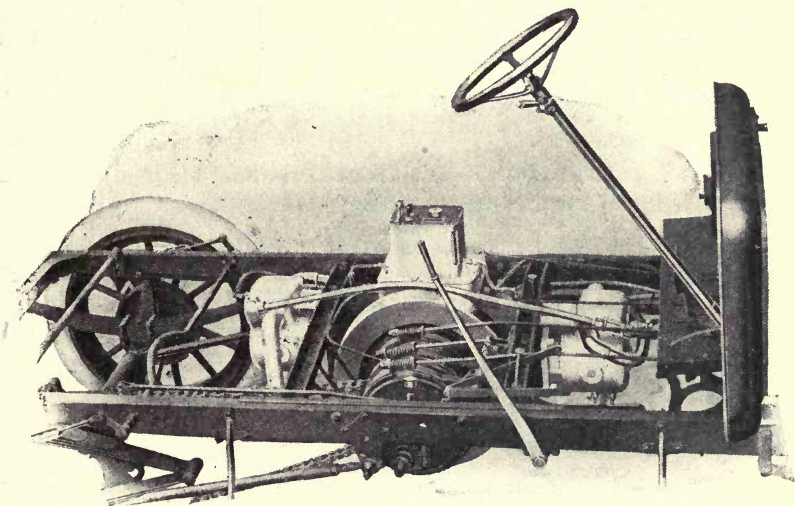

Fig. 96. Side View of Part of Chassis of Reo Car, Showing Constrictor-Band Clutches and Operating Rods.
Reo Motor Car Company, Lansing, Mich.

transmission system are more fully described under the heading of "Speed-Changing Gears."

Disc Clutches. With vertical automobile engines, the friction clutch is most generally a single disc in the form of a frustum or section of a cone, with a face several inches in diameter; or a series of flat discs. The disc or discs are either pushed into the fly-wheel (which has a corresponding hollowed-out portion) from the rear towards the front of the car, or are pulled into the fly-wheel towards the back on the squared portion of a coupling shaft between the engine and transmission. In this manner the rotation of the engine fly-wheel is transmitted to the shaft on which the clutch disc or discs are keyed. This clutch shaft is in turn connected to the so-called

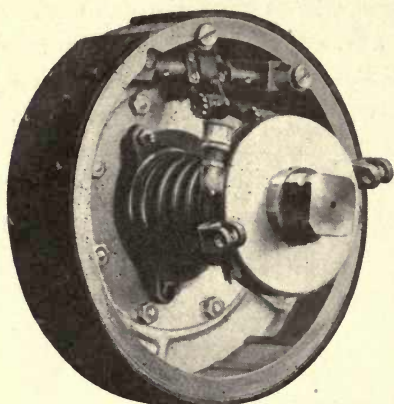

Fig. 97. Leather-Faced Disc Clutch.
Peerless Motor Car Company,
Cleveland, Ohio.

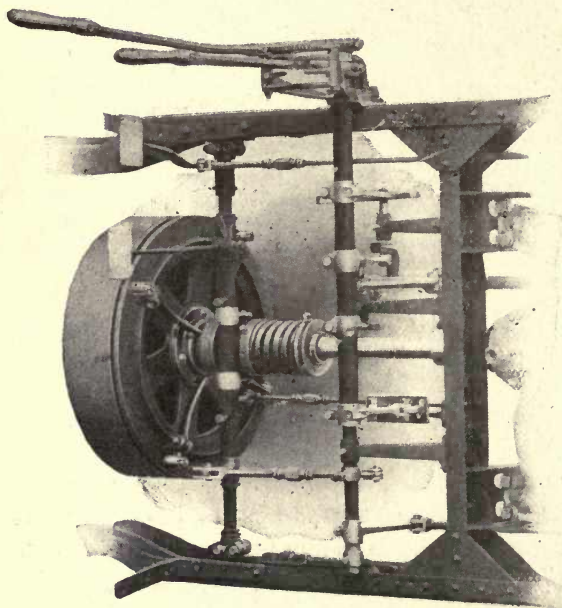

Fig. 98. Leather-Faced Conical Clutch in Position on
Chassis of Thomas Car.
E. R. Thomas Motor Company, Buffalo, N. Y.

transmission or speed-changing system, which connects to the rear or driving wheels.

The clutch is most frequently operated by means of a *push-pedal*. In some cars it is necessary to keep a downward pressure on the pedal, either with the foot or by means of a latching device, in order to keep the clutch in contact with the fly-wheel. In this type of construction, a stiff spring normally pulls the clutch out of engage-

ment, the pull of the spring being overcome by the pressure on the pedal.

Another type of construction is one in which a forward pressure on the push-pedal disengages the clutch from the fly-wheel and prevents the transmission of power from the engine to the transmission.

It is a very general mistake to consider it as part of the regular oiling

of an automobile to oil the leather face of the clutch. If the clutch is operating satisfactorily, it should not be disturbed. If it slips, it needs attention. Slipping of the clutch is caused by its

being too greasy and hardened by dirt. The remedy is to clean the leather with gasoline and then treat it with castor oil, spreading the oil all around, and allowing it to soak over night in order to make it soft and pliable.

In some cars the pliability of the clutch leather is increased by having grooves milled or chipped into the aluminum body of the disc,

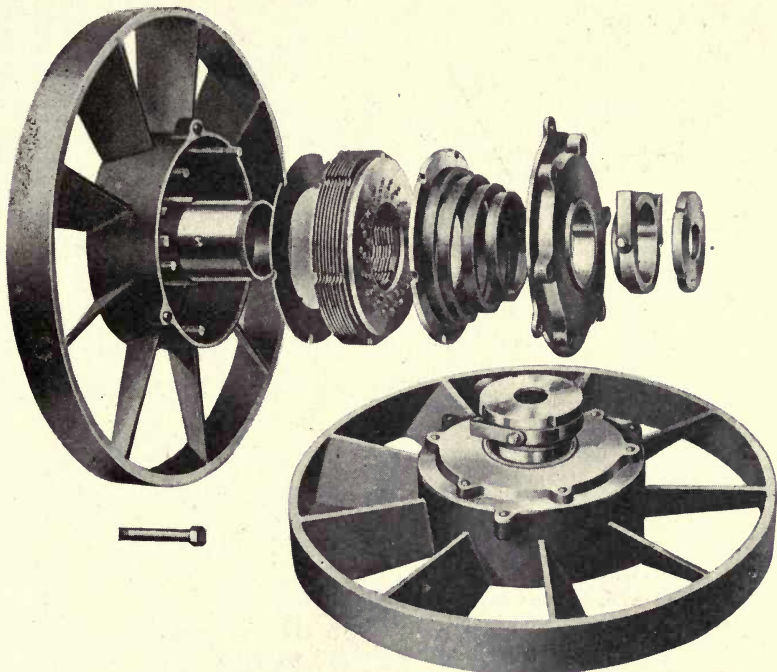

Fig. 99. Multiple-Disc Clutch of the Franklin Car.
H. H. Franklin Manufacturing Company, Syracuse, N. Y.

and placing short pieces of flat spring steel with a slight outward curvature in these slots. The outward pressure against the leather band, which, although riveted or stitched to the disc, is attached in such a manner as to be susceptible to this outward action of the spring steel, makes it very easy to engage the clutch gradually and without sudden gripping. A novice is inclined to throw the clutch in too suddenly.

Fig. 97 shows a conical leather-faced disc clutch as used in the Peerless car; and Fig. 98 shows a similar clutch as used in the Thomas car, mounted in position on the chassis.

Recently *multiple-disc clutches* have been superseding the leather-faced cone clutches, owing to the fact that the leather wears out pretty rapidly, and also the multiple discs can be put into small space and encased in oil. Fig. 99 shows this type of clutch as used in the

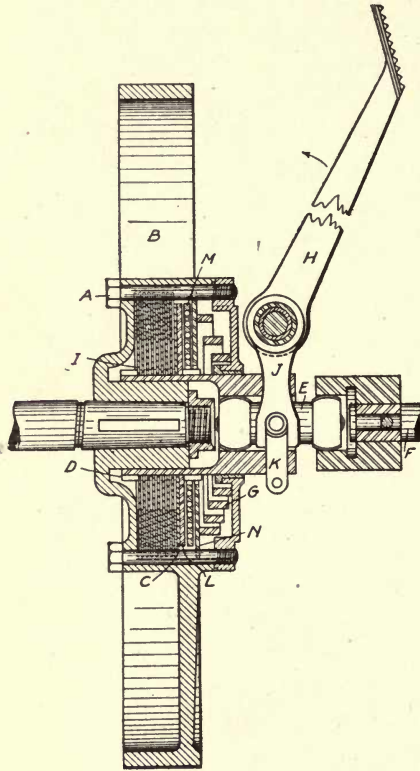

Fig. 100. Diagram Showing Construction of Franklin Multiple-Disc Clutch. H. H. Franklin Mfg. Co., Syracuse, N. Y.

Franklin car. The disc clutch is located within the fly-wheel. The discs are of phosphor-bronze and steel alternated, and run in an oil bath. The bronze discs revolve with the fly-wheel; the steel discs revolve with the clutch-driver. None of the discs can revolve independently, but they are free to slide together or apart; and when the clutch is let in, a spiral spring squeezes them together. As the oil between them is squeezed out, the bronze discs turned by the fly-wheel press against the steel discs on the clutch-driver, which is connected to the transmission shaft, and gradually revolve them by friction. This revolves the transmission shaft, and the car gradually starts.

This clutch is further illustrated diagrammatically in Fig.

100. The bolts *A* prevent the phosphor-bronze discs from rotating in the fly-wheel *B*, but the discs are free to move laterally. The steel discs *C* do not touch the fly-wheel, but are carried on the clutch-driver *D*, on which they are free to move laterally, but can rotate only with the clutch-driver. The clutch-driver, by means of the universal block *E*, is connected directly to the transmission shaft *F*.

The flat spiral spring *G* holds the plates firmly against each other when the clutch is engaged or whenever the foot-lever *H* is not pressed forward.

As the motor turns, it revolves the fly-wheel *B*; the discs *I* also revolve, being driven by bolts *A*. Because of the spring *G*, friction is exerted on the discs *I* and *C*, and the discs *C* are thus made to revolve. This rotates the clutch-driver *D*, because the discs *C* are fastened to it. The rotation of the clutch-driver *D* is communicated to the transmission by the square driving block *E*.

To throw out the clutch, the foot-lever *H* is pressed forward. This moves the clutch-shifter lever *J* backward, which carries with it the clutch-shifter trunnion *K*, which runs upon the clutch-driver *D*. As the clutch-driver *D* moves backward, it brings with it the ball thrust represented by *L*, *M*, and *N*. This compresses the spring *G*, relieving the pressure on the discs, which, being free to move laterally, separate; and oil, from the oil bath in which the clutch runs, fills up the spaces between the plates. When the clutch is released, the oil which has gotten in between the plates is released by pressure. While the oil is being removed, the clutch slips slightly and the car picks up gradually.

SPEED-CHANGING GEARS

Planetary Gears. The operation of constriction-band clutches used in connection with planetary gears has already been touched upon under the heading of "Clutches."

Fig. 101 is a view of a typical planetary gear set, as used in the Cadillac car. In this figure, the central gear *D* is the driving gear, and is keyed to the engine shaft. This drive gear meshes with the planetary pinions *FFF*, which in turn mesh with the internal gear *B*.

The driving sprocket and its frame are mounted on a journal which rotates freely about the engine shaft, either at the same speed forward as the engine shaft, or at slower speed forward, or at a slow speed in the reverse direction. The speed and direction of the sprocket depend on the operation of the clutches. If the lever is drawn which is attached to the high-speed clutch, the drum *K* becomes locked to the engine shaft. All of the gears are then inactive, and the entire gear set rotates as an additional fly-wheel, the sprocket turning at the same speed as the engine shaft.

For slow speed the drum *K* is held by the tightening of the slow-speed clutch band, preventing the drum from rotating. The plane-

tary pinions, rolling on the internal gear *B*, drive the same slowly forward, and with it the sprocket *A*.

For reverse, the case *H* is held by its constriction band; and

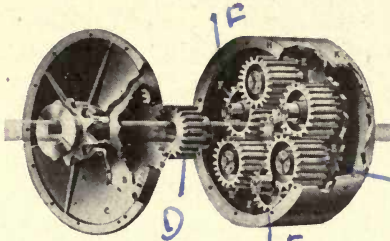

Fig. 101. Planetary Transmission Gear of Cadillac Single-Cylinder Car. Cadillac Motor Car Company, Detroit, Mich.

gear *B* is now driven in the opposite direction from the engine shaft, and with it the sprocket *A*.

Sliding Gears. The sliding-gear type of speed-changing device is by far the most generally used, particularly on touring cars and heavier cars in general.

The sliding-gear set consists of two sets of gears—one set mounted on a shaft to which they are rigidly fastened; and the other set mounted on a countershaft, which is either square between its journals, or with a long key so that the gears on it may be moved lengthwise along the countershaft and made to mesh in different combinations with the gears that are fixed in position on the main shaft.

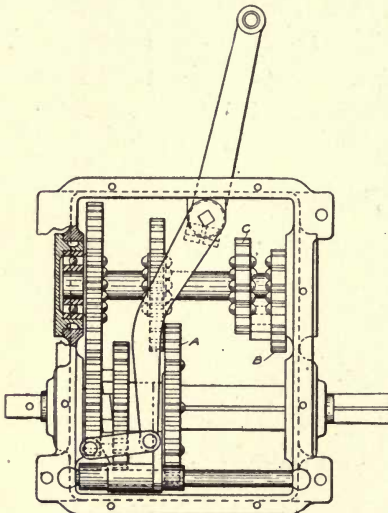

Fig. 102. Sliding Transmission Gear of Franklin Car. H. H. Franklin Mfg. Co., Syracuse, N. Y.

The operation of the sliding-gear set on any car can be easily learned by removing the gearbox cover and moving the gear-

shifting levers, watching the resulting gear meshings.

Fig. 102 shows the sliding-gear set of the Franklin car. The cut shows the position of the gears for direct drive, or high-speed gear. For reversing, gears *A* and *B* are in mesh. For low speed, gears *A* and *C* are in mesh.

Fig. 103 is another example of a sliding-gear set as used in the Autocar. The shaft *A* is the main drive shaft, on which the clutch is mounted. Gears *B* and *C* are practically one piece, and are car-

ried along the squared shaft *D* by a sliding fork connected by rods to the gear-shifting lever (this fork is not shown in the illustration). Shaft *A* is separate from shaft *D*; that is, they can revolve at different speeds. For the slowest speed, the slide gear *BC* is moved along the squared shaft until *C* is in mesh with *E*. For the reverse, *C* meshes

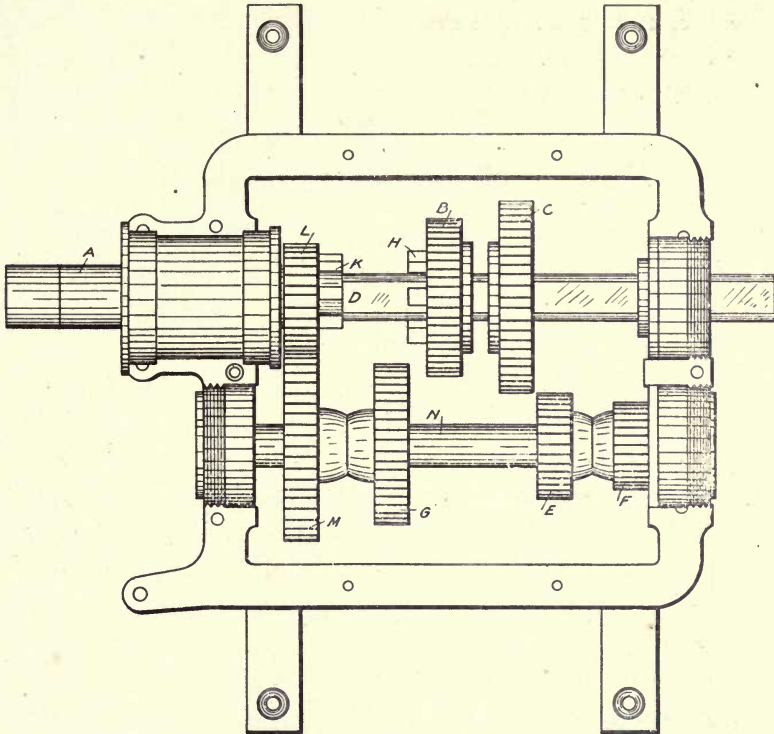

Fig. 103. Sliding-Gear Set of Autocar.
Autocar Company, Ardmore, Pa.

with an idler connected with *F*. For the intermediate speed, *B* meshes with *G*. For high speed or direct drive, the teeth *H* engage with the teeth *K*, and *D* rotates at the same speed as the engine shaft. At all times *L* is in mesh with *M*, and so drives the countershaft *N*. At the rear end of *D*, is the universal joint connecting the gear set with the rear axle.

All modern cars that use sliding-gear sets are provided with some arrangement whereby the clutch is disengaged during the gear-shifting process, in order to prevent grinding of gears during changes.

Speed-Changing Levers Operating Sliding Gears. Some cars have separate levers for high and low speed. Some use a lever for high speed, and a foot-pedal for slow speed; and in such cars the operator must be careful never to throw the high-speed lever forward before the low-speed lever is released, or *vice versa*.

Some makers use a single speed-changing lever on the right side of the car, usually nearer the operator than the brake lever, which is

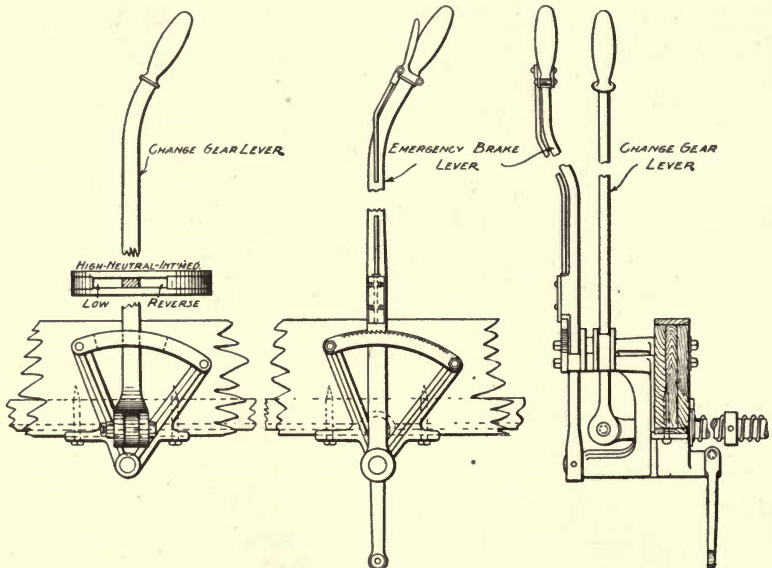

Fig. 104. Emergency Brake and Change-Gear Control.
H. H. Franklin Manufacturing Company, Syracuse, N. Y.

generally the outside lever where there are two levers on the right side of the car. With this variety of speed-changing lever, there is usually a piece in the form of a quadrant or arc of a circle located near the lower part of the lever. This quadrant is provided with notches that catch a pawl with a spring back of it, which is compressed and consequently released by the hand pressing on a grip operating a rod leading to the spring. These notches or steps are located at the points for proper meshing of gears, or of tightening of clutch-bands for the various speeds.

A still further range in a limited space is obtained in the Thomas, Franklin, Peerless, and other cars, by means of a lateral movement of the speed-changing lever so that it has two paths in

the quadrant—an inner and an outer path—each path provided with notches.

Fig. 104 shows this type of lever and quadrant as used in the Franklin car; and Fig. 105 shows a similar set as used in the Peerless

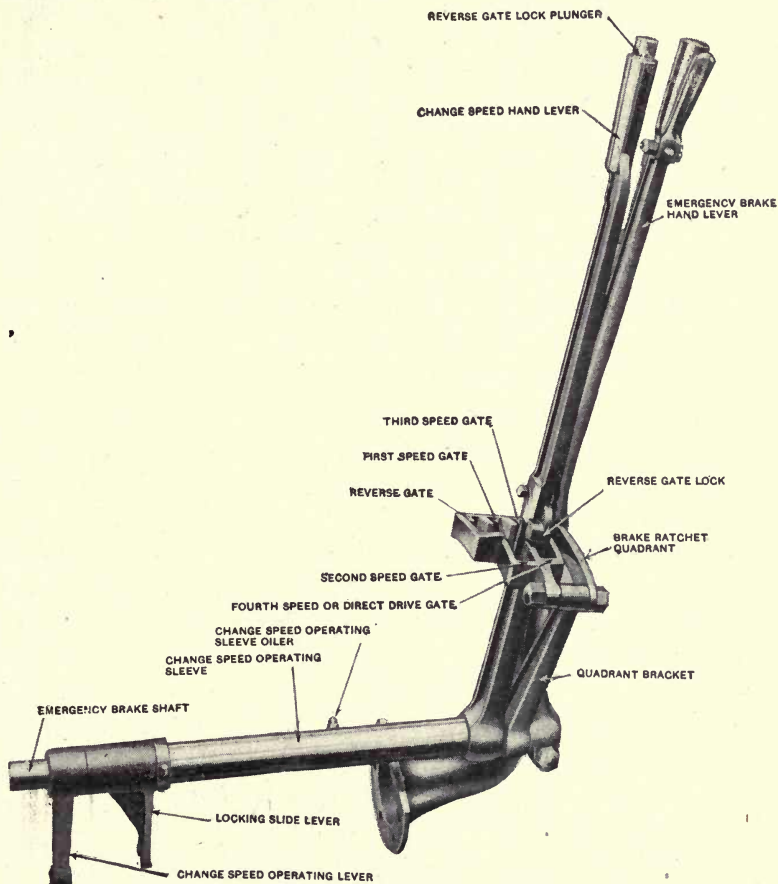

car. Referring to Fig. 105, it will be seen that the lever can be thrown into five notches. When the lever is in neutral position between the notches, none of the gears are meshed, and the motor runs free.

In the first speed, the driving is through the direct-drive sleeve, countershaft gear, first-speed pinion, and first-speed gear (see Fig.

106, which shows the sliding gears of the Peerless car). Second speed is through direct-drive sleeve, countershaft gear, second-speed pinion, and second-speed gear. Third speed is through direct-drive sleeve, countershaft gear, third-speed pinion, and third-speed gear. High speed is through direct-drive gear meshing internally with third-speed gear, thus making a direct drive.

For the reverse, the driving is through the countershaft pinion, countershaft gear, first-speed pinion, and reverse idler gear that reverses first-speed gear.

The most desirable arrangement for direction of lever movement for reverse, is one in which the lever must be pushed backward from neutral notch towards the rear of the car, as this seems the natural movement to produce *backing up*.

Use of Speed-Changing Levers in Operating Car. Before pushing lever into high gear, start on low gear, then throw into middle gear, and then into high speed.

To stop the car, disengage the clutch where the clutch is operated by a foot-pedal separate from the hand-levers. This plan is advocated because it facilitates quick stopping. Remember, however, that you have not "finished your job" until the speed lever has been thrown into "neutral" or "off" position. You are likely to forget this, although remembering the other details in regard to stopping your engine, with the result that when you throw in the clutch you start off on high speed.

In cars where a foot-pedal throws in the clutch, be sure that the speed-selecting lever is fully in position for proper meshing before the clutch pedal is let into connection; otherwise the gear teeth may be only partly in mesh, and the sudden strains of starting would be liable to damage the gears.

CAUTION. *Engage but one gear at a time.* A serious chance for confusion and breakage is offered the operator in makes of cars employing separate levers, by the fact that in some cars the slow-speed lever is used as a reverse lever by pushing it into its extreme forward position, instead of by adopting the suggestive and natural method of accomplishing reverse by a backward throw of the lever.

In all cars employing two levers for speed changes, be absolutely sure that one lever is thrown into neutral position before the

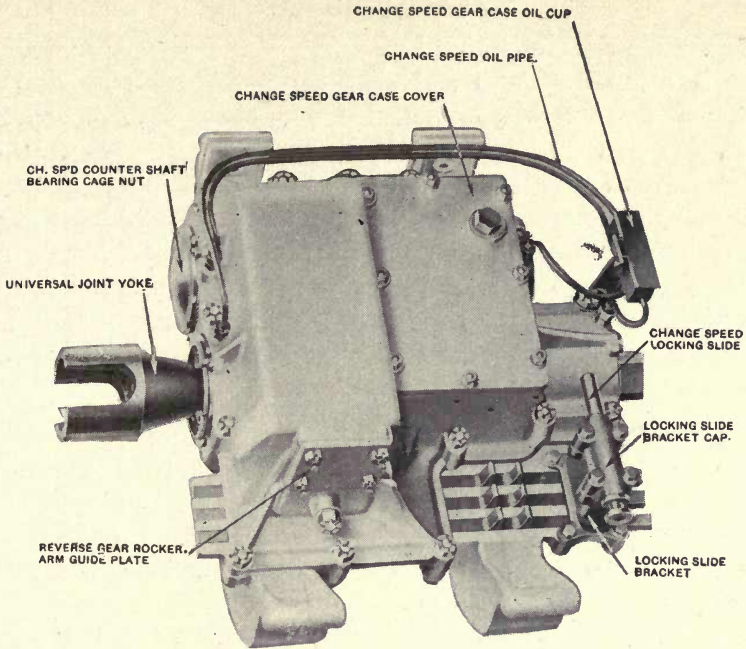

Speed-Changing Gear Set, in Case.

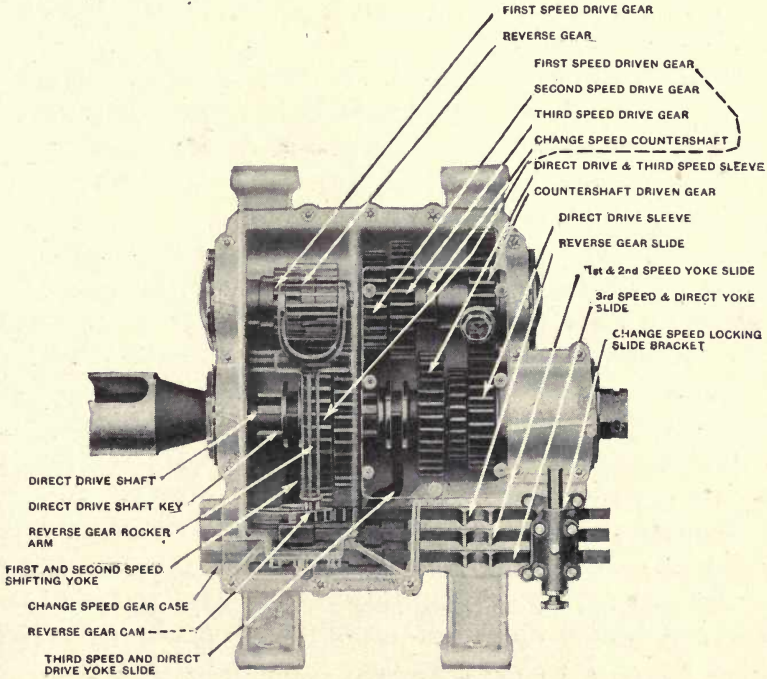

Fig. 106. Speed-Changing Gear Set, Cover Removed.
Speed-Changing Gear of Peerless Car.
Peerless Motor Car Company, Cleveland, Ohio.

other is engaged. The neutral position would naturally be the center of the arc or quadrant; but here again different makers differ.

Although some cars are so constructed that the meshing of one lever *locks*, or prevents any other lever from being thrown into mesh, there are many makes of car which are not "fool-proof" in this respect. A novice, thinking he has to put on his slow speed before reversing, and then put on his reverse, is liable to damage something in some makes of cars where he can put both in mesh at the same time.

Changing Gears. A driver will soon become familiar with the approximate speed corresponding to each set of gears, especially if he compares the speed as he sees and feels it with the odometer readings. In changing gears, the car should first be brought by means of the spark and throttle regulation to very nearly the speed of the gear to which it is desired to change.

In changing from low to high, the movement on the gear lever should be quick, so that meshing of the teeth is done promptly without any grating. In changing from high to low, the movement does not need to be so rapid.

Difficulty in Changing Gears. If there is difficulty or noise in changing gears, it is likely to be due to worn or loose bearings, or loose pinions, or loosening of the gear case. A new car should not be accepted if there is difficulty or noise in changing gears, although this feature is neglected by many makers.

Grinding Gears. Occasionally a car is found which gives the operator considerable trouble in changing from one gear to another, owing to the gears grinding together instead of going into mesh easily. If this trouble appears by degrees in a car ordinarily well-behaved, it is a pretty sure indication that the gear-shaft bearings have been cut so that the shafts are badly out of line, and trouble of this sort should be investigated at once, as nothing will wear the gears so fast as to mesh improperly.

Running on High-Speed Gear. Where there are three speeds, the highest speed is usually the direct. In some instances where there are four speeds, the third is the direct. It is generally considered best to keep on the direct-drive gear as much as possible, because it gives less heating, and there is less friction in engine and

transmission and less lost work. When the engine speed gets so low that the strain is felt in each stroke in the parts, it is best to change to lower gear.

The prevalent fad of climbing all hills on the high-speed gear is a great mistake. Although it may be possible to force a car up a hill on this gear, the time taken will be as a rule just as long as if the lower gear had been used, and the strain on the engine and transmission is unnecessarily great.

DRIVE

The clutch and clutch-shaft constitute the connecting portion between the engine and the speed-changing or transmission systems. The term *transmission*, in its general sense, includes also the connections between the transmission or speed-changing gears and the rear-axle driving system. The prevailing types of transmission from the gears to the rear system, and generally designated by the term *drive*, are:

1. Single-Chain Drive.
2. Double-Chain Drive.
3. Direct or Shaft Drive.
4. Friction Drive.
5. Cable Drive.

It is claimed that the single-chain drive is more efficient than either the shaft or double-chain drive. However, a single-chain system necessitates the hanging of the engine lengthwise with the chain, or the use of an extremely long chain extending to an engine under a hood.

The shaft drive is generally acknowledged to be more efficient than the double-chain drive, because there are fewer points of friction. The shaft drive eliminates two bearings, besides doing away with both chains and four sprocket-wheels.

The direct drive requires the use of one or two universal joints to provide for any change in alignment between the clutch-shaft and the rear-axle drive-shaft. The *universal joint* has been a part of automobile mechanism that has caused a great deal of trouble to manufacturers whose design of joint has not been liberally and accurately proportioned and made of the best material. These difficulties have been overcome as designs of universal joints have improved; and for several years, every Vanderbilt race has been won with a shaft-

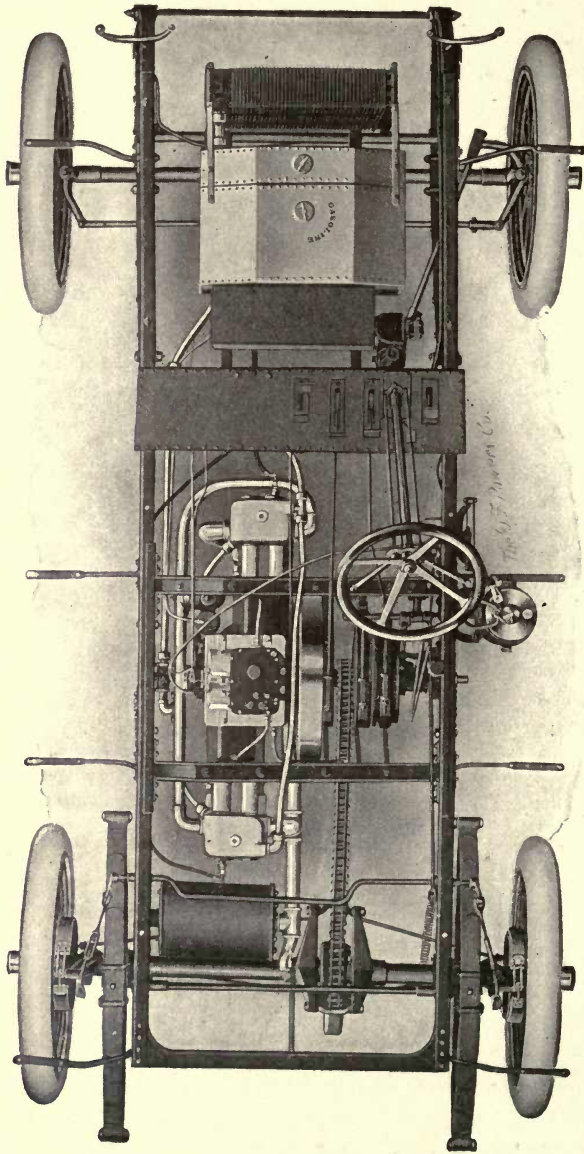

Fig. 107. Chassis of Reo Two-Cylinder Car, Single-Chain Drive.
Showing how motor is placed in frame, and power transmitted from engine to rear wheels.
Reo Motor Car Company, Lansing, Mich.

driven car. The shaft drive can be made dust-proof, which cannot be said of the chain drive. The chain drive is much more exposed to dust, and has many more wearing parts.

Still another type of transmission is the so-called *friction* transmission. In this system, a disc of from 18 to 30 inches diameter is keyed to the rear end of the clutch-shaft. Its rotation is transmitted by means of an intermediate disc placed at right angles to the first one, and through it to a third disc parallel to the first and keyed to the drive-shaft. The intermediate disc or cone—or set of them, there being sometimes two—is arranged so that it can be drawn outward or pushed inward, the rim thus bearing on the face of the disc mounted on the clutch-shaft, at varying radial distances from its center. As the bearing surface is drawn further out, the rotational speed is increased. This type of transmission is being applied to an increasing number of medium-weight and light-weight cars.

Fig. 107 is a view of the Reo car chassis, showing a good form of single-chain drive.

Fig. 108 shows a double-chain drive as used in the American Locomotive car.

Fig. 109 is a view of the Studebaker Model "L" chassis, showing direct-drive shaft with two universal joints.

Fig. 110 is a view of a two-disc friction transmission with single-chain drive, as used in the Cartercar.

Cable drive is employed in the Holsman car, the cable passing over sheave wheels, a small one on the drive-shaft and a large one on the axle.

Universal Joints. Fig. 111 shows in detail the construction of a universal joint as used by the National Motor Vehicle Company, Indianapolis, Ind. This joint is located immediately in rear of the transmission gear case, the main steel portion *A* being attached to the shaft of the transmission by the two keys *B*, indicated by dotted lines.

On the end of this portion is an annular bearing *C* held by the nuts *D*, with a lock-washer *E* between them. This bearing, and therefore the main portion of the universal joint, are prevented from pulling out of the case by the end adjuster ring *F* screwed into the main bearing sleeve *G*, and prevented from becoming unscrewed by the locking key *H*. The driving shaft *I*, turned to a ball

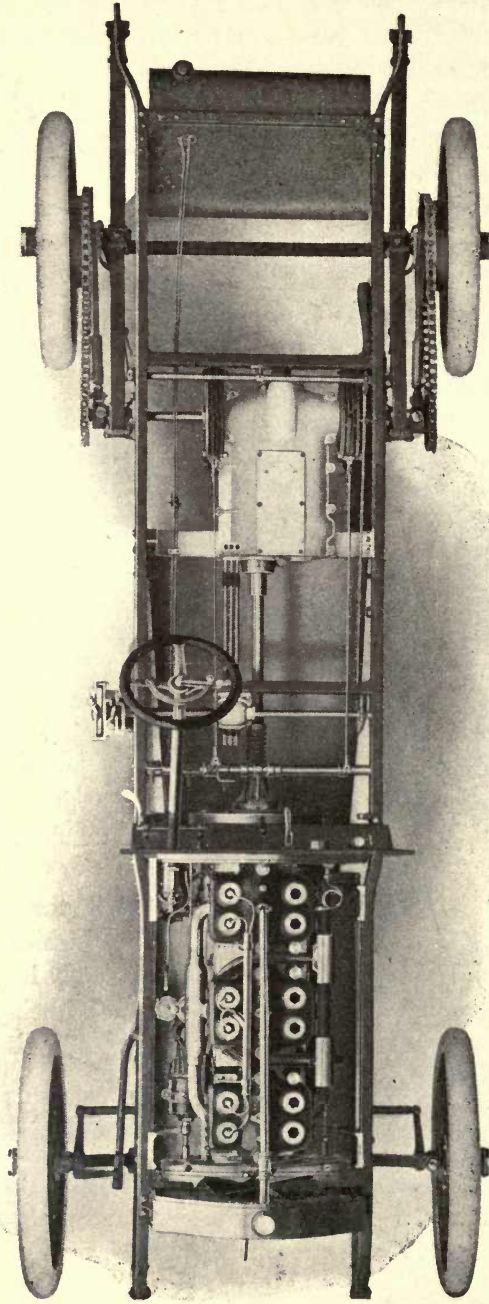

Fig. 108. Chassis of a Six Cylinder American Locomotive Car, Double-Chain Drive.
American Locomotive Automobile Company, New York, N. Y.

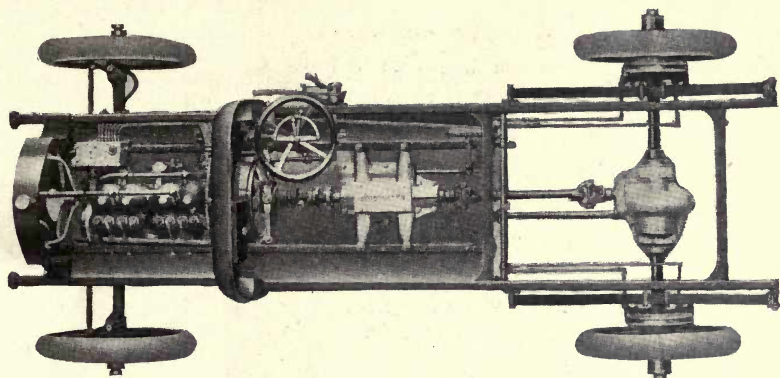

Fig. 109. Chassis of Studebaker Model L Car, Showing Direct or Shaft Drive, with Two Universal Joints.
Studebaker Bros. Mfg. Co., South Bend, Ind.

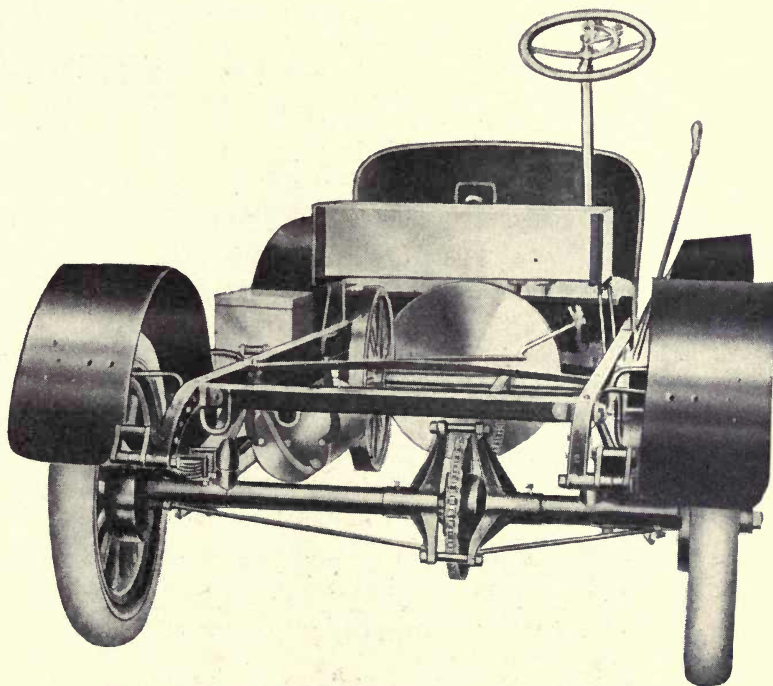

Fig. 110. Two-Disc Friction Transmission as Used in Cartercar.
Motor Car Company, Detroit, Mich.

shape at one end, has the hardened pin *J* running through it, upon which work two steel squares *K* sliding in slots in the main portion of the joint *A*, thus permitting a universal movement and also the sliding fore-and-aft movement of the driving-shaft, due to the ac-

tion of the springs.

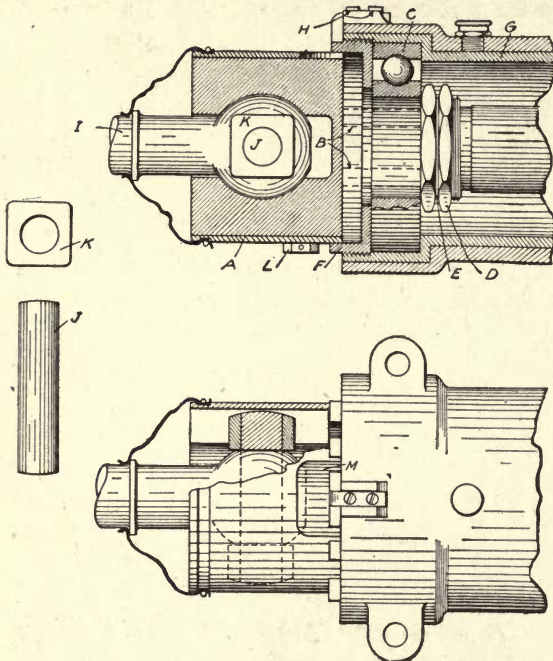

Fig. 111. Details of Universal Joint in National Car. National Motor Vehicle Company, Indianapolis, Ind.

There is a tubular sleeve which encloses the working parts of this joint, which is held in place by the cap screw *L*. An oval hole in the sleeve at *M* allows the removal of the squares, and permits the packing of the joint with grease, by turning it through an angle of 90 degrees. The end of the joint is covered by a cone-shaped piece of rawhide, fastened at one

end to the sleeve and at the other end to the drive-shaft. A small hole through the center of the shaft allows some oil to flow into the joint from the transmission case.

Differentials or Balance Gears. When a car is turning a corner or passing over uneven places in the road, one rear wheel must turn faster than the other. It is necessary to provide mechanical means for this unevenness of turning, at the same time that uniform rotating power is furnished through the drive-shaft or driving sprocket.

Figs. 112 and 113 show how this is accomplished by means of the *differential* or *balance gear*. Fig. 112 is a view of the Studebaker Model F rear axle, showing housing removed and balance gear dis-

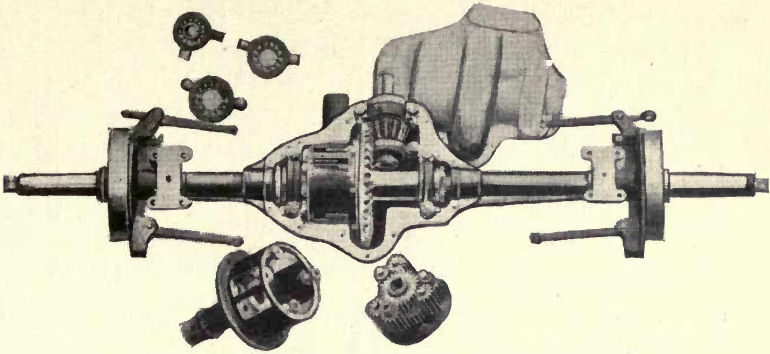

Fig. 112. Rear Axle Showing Differential or Balance Gear as Used in Studebaker Model F Car. Studebaker Bros. Mfg. Co., South Bend, Ind.

sected. The small bevel pinion in the center of the cut is attached to the driving shaft. It meshes with the large bevel gear. On the inside of this bevel gear, is fastened a plate on which are mounted on short projecting shafts a number of small pinions, which mesh with gears fitting onto the square ends of the right and left rear axles respectively. The amount of force transmitted is equal toward both

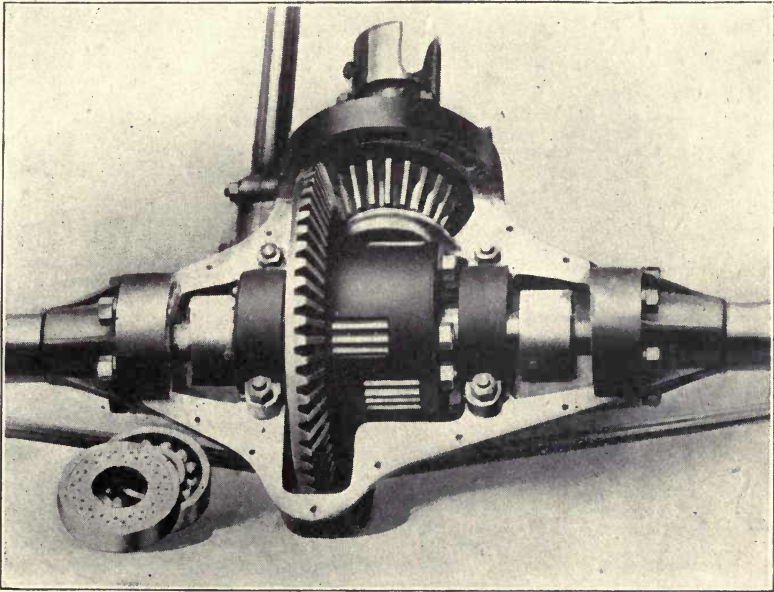

Fig. 113. Peerless Differential Gear. Peerless Motor Car Company, Cleveland, Ohio

sides, and variations of speed between the two rear wheels are taken care of by rotation of the small pinions in opposite directions. Fig. 113 is a view of the Peerless differential. The principles of action are the same as in the one just described, the only difference being that small pinions carried on the large driven bevel gear are located directly in the center of the rear axle in line with the driving pinion.

Owing to the heavy strain on the large driven bevel gear,

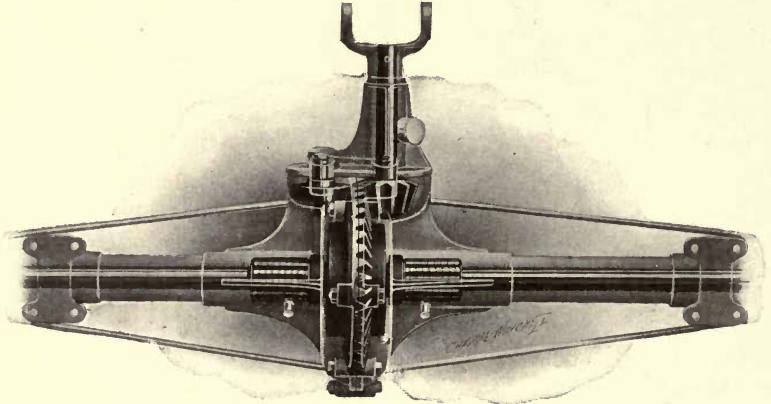

Fig. 114. Rear-Axle Construction on Maxwell Car, Showing Roller Thrust to Relieve Strain on Large Driven Bevel Gear of Differential
Maxwell-Briscoe Motor Company, Tarrytown, N. Y.

a number of makes provide a *thrust roller-bearing* against the back of the large bevel gear—that is, on the side opposite the teeth.

Fig. 114 is a view of the rear axle of the Maxwell car, showing this roller thrust.

LUBRICATION

Pipes for lubrication should not be too small. Sharp turns in oil pipe-lines should be avoided.

Oil and Oiling. The life and amount of service and satisfaction to be obtained from a motor depend very largely on the amount and quality of the oil used. The proper gas-engine cylinder oil should have a flash point of about 500 or 600 degrees Fahrenheit, and should contain only the minimum amount of carbon. It should always be filled at the temperature used. This necessitates using a different weight of oil in warm weather from that

used in cold weather. For warm weather, use a heavy oil; and as the weather grows cooler, change to a lighter oil.

A teaspoonful of powdered graphite mixed with a little water inserted through the relief-pipe, will occasionally help greatly to reduce the amount of oil used.

The oil should be entirely drawn from the engine case about once a month, and all of the parts washed with kerosene. In refilling with oil, it should be deep enough so that when the connecting rods are down they will dip into the oil about $\frac{1}{8}$ inch.

After cleaning, running the engine for a few revolutions with the case filled with kerosene will cut out any oil which may have become gummed on the cylinders or about the piston rings.

If the motor has not been run for some time, this should be done. If the motor is in constant service, it is not necessary, though it will do no harm.

For the transmission gears and differential gears, use a heavy oil corresponding to a steam-engine cylinder oil of cheap grade. Each of these gear cases should be about one-third full. For universal joints, use Albany grease. This is better than vaseline, as a slight heat transforms vaseline into liquid, and it runs out.

If springs squeak, force a small quantity of oil into the joints.

There is usually altogether too much lubricating oil applied to an engine. Six to eight drops a minute is ample for cylinder lubrication.

Chains, after having been thoroughly cleaned with kerosene, are dipped into melted tallow, and replaced after the tallow is cooled.

Forgetting to lubricate bearings is likely to cause firing of bearings, or *hot boxes*, which will necessitate stopping and delay.

The greatest drawback to the success of air-cooled motors, it has been claimed, is the problem of lubrication. The following method is adopted in the Marmon car to solve this problem:

The crank-shaft is drilled with one-inch holes from end to end through the main bearings and through the four crank-pins. Three-eighths-inch holes are drilled through the arms of the cranks, connecting with the one-inch holes. It is claimed that this drilling does not weaken the shaft—in fact, that it strengthens it by removing internal strains on the forging. After the drilling is done, the outer ends of all the holes, except the one in the fore end of the shaft, are plugged, thus forming a continuous oil passageway from the forward

end entirely through the shaft into the rear main bearing. The crank-shaft is then drilled with radial holes at the center of every bearing, and these holes lead the oil from within the shaft directly into the bearing. A pump draws the oil through a screen from the bottom of the oil well, and forces it through a tube into the end of the crank-shaft, maintaining a uniform pressure constantly. It is claimed that oil smoke is never seen coming from the muffler of an engine with this type of lubrication.

Mechanically Operated Lubricators. Gravity and pressure systems of lubrication depend upon needle-valves, and the oil supply

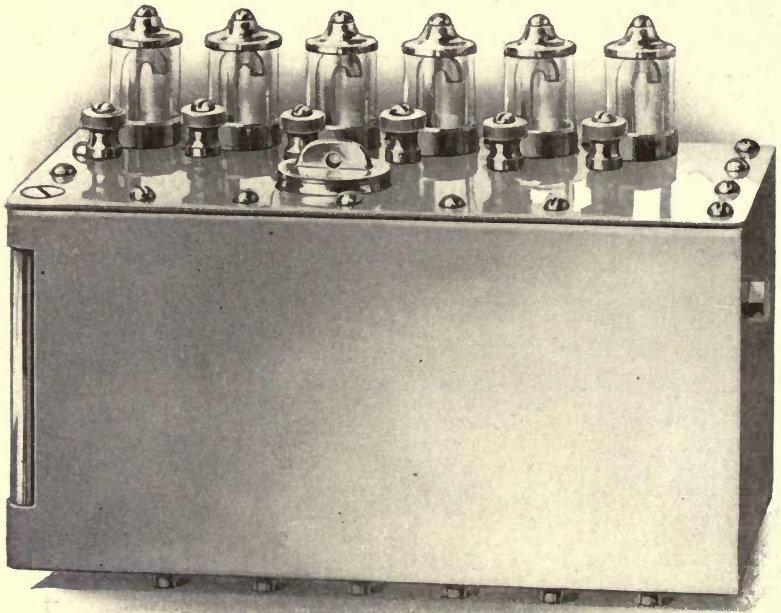

Fig. 115. External View of McCord Force-Feed Lubricator (Six Feeds);
Polished Sheet-Brass Reservoir, Rotary Drive.
McCord & Company, Chicago, Ill.

is the same for all speeds. Needle-valve regulation is difficult, because it is interfered with by the slightest particle of foreign matter in the oil and by temperature changes. An engine running at high speed requires more oil than at slow speed. Too much oil gums the bearings and cylinders, and increases friction; and with too little oil, they are liable to damage. Oil for automobile lubrication has to pass through a number of feet of small tubing before it reaches

the points of lubrication, and requires in some cases to be delivered against pressure.

To provide for all of these problems, *mechanically operated lubricators* have been devised, which consist of pumps driven by some mechanism connected to the engine, so that when the engine starts the oiling begins at once, being so regulated that it varies in proportion with the engine speed and stops when the engine stops.

Figs. 115 and 116 are external and sectional internal views, respectively, of the McCord Force-Feed Lubricator. This lubricator consists of a rectangular reservoir and cover, provided with a filling opening closed by a plug *U*, the oil, when poured into the reservoir, pass-

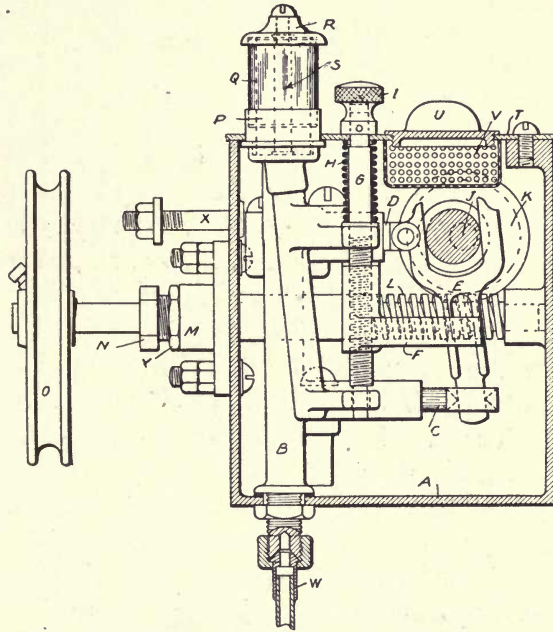

Fig. 116. Construction and Operation of Mechanically Operated Force-Feed Lubricator.
A—Reservoir; *B*—Pump; *C*—Pump Plunger, Suction; *D*—Pump Plunger, Delivery; *E*—Driving Yoke; *F*—Driving Yoke Fulcrum; *G*—Regulating Stem; *H*—Regulating Stem Spring; *I*—Regulating Button; *J*—Eccentric Shaft; *K*—Worm Gear; *L*—Worm; *M*—Stuffing Box; *N*—Stuffing Box Gland; *O*—Driving Wheel; *P*—Sight-Feed Glass Socket; *Q*—Sight-Feed Glass; *R*—Sight-Feed Glass Cap; *S*—Sight-Feed Nozzle; *T*—Cover; *U*—Strainer Plug; *V*—Strainer; *W*—Outlet Union Nipple; *X*—Studs; *Y*—Stuffing-Box Gland Lock-Nut.
 McCord & Company, Chicago, Ill.

ing through a perforated sheet-metal strainer *V* which prevents any solid particles from getting into the tank. The force-feed mechanism consists of pumps *C* and *D*. The stroke of the pump *C* can be adjusted from the top of the lubricator without removing the cover. The second pump *D* has a constant stroke, and forces the oil after it has dropped through the sight-feed glasses *Q* onward to the point of lubrication. At the bottom of the sight-feed glasses, a gauze screen is placed as an additional protection to prevent even the

smallest particle of foreign matter from being forced to the bearings. This is in full view of the operator, and can be removed and cleaned by taking off the brass cap. These sight-feed glasses are simply a protecting case for the oil drops, and contain no liquid adhering to the glass, which has always been a great disadvantage in the liquid sight-feed glasses. The amount of oil being pumped is at all times visible to the operator. The operation is as follows:

The pumps are driven by the eccentric *J* and adjustable lever *E*, by means of a worm gear *K* connected to the cam-shaft or other rotating part of the engine by the pulley or sprocket *O*. (In some lubricators this wheel is a thin ratchet wheel actuated by a pawl.) The stroke of supply-pump *C* is varied (thus increasing or diminishing the amount of oil pumped) by means of the sliding arm *F*, which forms a movable fulcrum for the pump-lever *E*. When the regulating stem *G* is screwed down, the fulcrum is raised and the stroke of the pump-piston is lengthened. Lowering the fulcrum decreases the stroke of the pump-piston and diminishes the amount of oil pumped. This pump delivers oil through the oil standpipe *S*, from which it drops to the delivery pump *D* attached to the jaws of the operating lever. The stroke of this pump is constant, and every drop of oil which falls into the pump chamber must be forced out through the delivery pipe *W* and on to the point of lubrication.

With the car running from fifteen to twenty miles an hour, each cylinder oiler should show ten drops per minute.

As a typical illustration of where lubrication should be applied, and how often, it will be well to study carefully Figs. 117 and 118, which show plan view and side elevation respectively of the Peerless car, with lubricating points plainly designated.

For this car the following lubricating instructions are given:

DAILY OIL AND GREASE

Eight grease cups should be given careful attention by the operator. These are located as follows: (1) On the right of the water pump, exhaust side of motor; (2) and (3) on the front end and rear end of the connecting rod which joins the steering column with the steering knuckles; (4) on the outside of the casing enclosing the worm and sector mechanism at base of steering column; (5) on the cranking device directly under the radiator well in front; (6) on the collar behind the spring on the clutch; (7) on fan-shaft; and (8) on driving-shaft between clutch and transmission. The above-mentioned grease cups should be filled with grease and screwed up a turn every day

before starting on a trip. When the caps have been screwed down as far as possible, unscrew, and fill again with grease.

Small oil-cups are located in the following positions:

Top of case covering half-time shaft to water-pump.

On brass cover operating drive to main oil-pump.

At end of all springs, to allow easy working of springs.

On the steering knuckles and at ends of cross-rod attached to steering knuckles.

On all rods pertaining to the brake and clutch mechanism.

On all knuckles pertaining to the brakes.

An oil-cup is located on top of the shaft in the commutator box. This should be given attention at frequent intervals, to have the bearings well lubricated. Half-way down the vertical casing carrying the commutator shaft, is another small oil-hole. This shaft should be oiled occasionally.

The slots through which the brake-equalizers work should have some oil occasionally.

The entire lubricating system should be thoroughly gone over every month, to insure perfect running of the car. Too much oil is better than too little, and it is advisable that the operator give this his most careful attention.

Oil in Crank-Case. The correct level of the oil in the crank-case is regulated by standpipes connected with pet-cocks underneath the crank-case. Before starting on a run, it is important to know that the crank-case is properly filled. Open both crank-case oil gauge-cocks; and if the oil runs out, allow it to run until the excess is all withdrawn. If the oil does not run out of the pet-cocks, fill the crank-case through the vent-pipes until the oil commences to drain off through the pet-cocks. Care should be taken not to open the crank-case drain-cocks.

Transmission. The transmission case should be filled with about five pounds of grease to which is added about a quart of light paraffine oil. This lubricates the shafts, yokes, levers, and in fact all wearing parts. The four bearings are lubricated by a manifold oiler located at the front of the transmission case. This manifold should be filled before starting on a trip. An oil-hole in the cover of the transmission case allows opportunity to refill the transmission with grease and oil at any time it is deemed necessary. This should be at least once a month.

At the end of three months the top of the transmission case should be removed, and the case flushed with kerosene and refilled with grease and oil. This may be done by drawing off the oil through the drain-plug at the bottom of the transmission case.

Universal Joints. The universal joints between the clutch and transmission and between the transmission and the rear axle are packed in grease, and housed in leather cases held securely in place by a brass band easily removable for replenishing with grease. This should be done about once in two months.

Wheels. The wheels should be taken off, cleaned, and packed with grease about once in two months or oftener, depending on usage. The oilers on top of the rear and front hub should be filled daily.

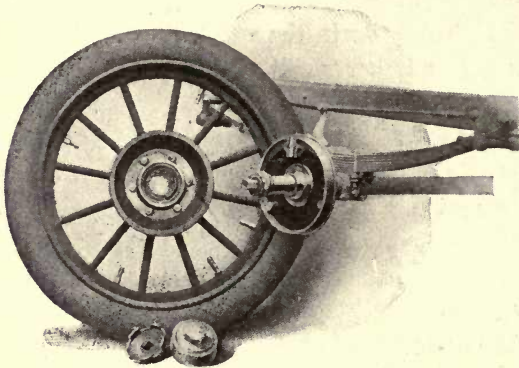

Fig. 119. Rear Wheel of Studebaker Model G Car, Showing Hub Drum and Brake. Studebaker Bros. Mfg. Co., South Bend, Ind.

Differential. Under ordinary conditions the bevel and differential gears should be cleaned once in three months.

The cover of these gears should be taken off, and all the old grease removed and the gears carefully packed with new grease, care being taken to see that the grease is well worked in. The differential case holds about seven pounds of grease. By means of a plug in the differential case, it should be replenished with grease and oil at least once a month.

BRAKES

Most cars are provided with two brakes—one known as the *ordinary brake*, and the other as the *emergency brake*. It is most convenient for the operator to have the ordinary brake operated by a foot-pedal, and the emergency brake by means of a lever.

Formerly one of the brakes was applied to the clutch or drive-shaft. This method has been found to throw an undue strain on these parts, and the best modern practice is in favor of *internal* and

external brake-bands acting on hub drums on the rear wheels, one of these serving as the ordinary brake, and the other as the emergency.

Fig. 119 shows the rear wheel of the Studebaker Model G car, showing location of hub drum and brake.

Fig. 120 shows the internal and external brake system of the Peerless car. In this car the brakes act on a drum on each wheel, being operated through equalizers which give an even pressure on each

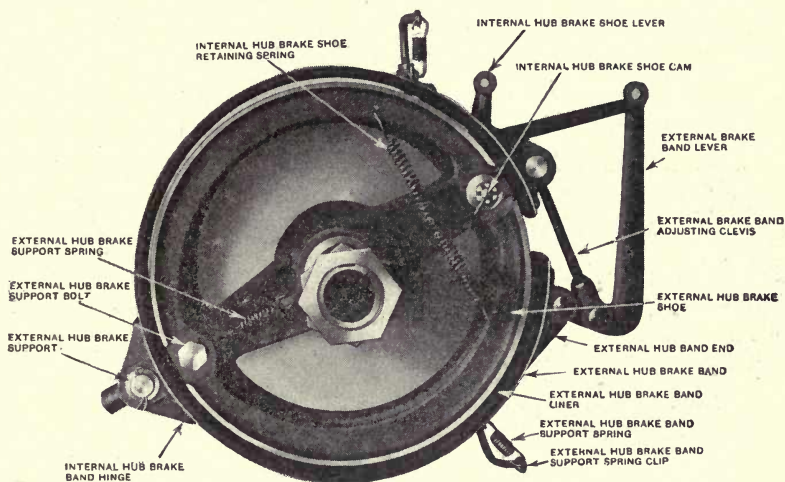

Fig. 120. Internal and External Brake System of Peerless Car, Showing Details Connected with Operation. Peerless Motor Car Company, Cleveland, Ohio.

wearing surface. The foot-brakes are made of steel bands, fiber-lined, and operate on the drums externally. When not engaged, the external bands are kept from the drum by means of springs at top and rear.

The emergency hand-brake operated by the outside lever on the right-hand side of the car, engages the drums internally. These brakes are bronze bands expanded by a wedged cam-lever. These brakes are held away from the drum by means of springs, as shown in the figure.

After a time it may be found necessary to adjust these brakes to take up for wear. This may be done by screwing up the brake-rod clevises to the rear of the equalizers, until the proper adjustment is reached. Care should be taken not to screw up these clevises so far that the band will *drag* on the drum. By jacking up the axle so that

the wheels clear the floor, and spinning the wheels around by hand with the brakes in released position, it may be readily noticed if there is any dragging action.

Fig. 121 shows a brake drum of the Premier car, with details of the internal expanding and external contracting brakes.

BEARINGS

Bearings are either *plain cylindrical*, *cylindrical in halves*, *roller bearings*, *ball bearings*, or *annular*.

Plain cylindrical bearings are usually bronze sleeves, and are used at points where no adjustment is expected to be necessary.

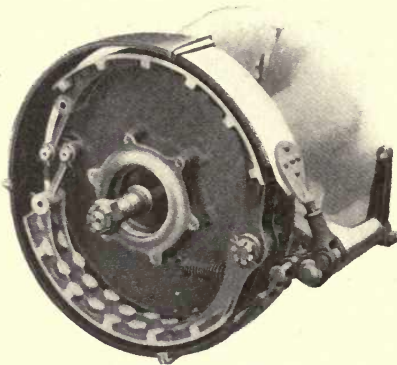

Fig. 121. Brake Drum.
Showing detail of internal expanding and
external contracting brakes.
Premier Motor Mfg. Co., Indianapolis, Ind.

Cylindrical bronze bearings cast in halves, the halves being separated by shims of soft metal or leather liners, are used in various parts of different makes of cars, a good many cars using this type in the main or crankshaft bearings of the engine. In this type a moderate amount of wear may be taken up by tightening the cap screws which fasten the halves of the journal-boxes together. A greater amount of wear may be taken

up by removing the liners or shims, and replacing with others somewhat thinner.

Fig. 122 shows the American Ball Bearing Company's front hub. The nut *A*, which adjusts the cone *D* on the right-hand axle, is provided with a right-hand thread, and the set screw *B* has a left-hand thread. The dust cap *C* has a left-hand thread. All of these parts on the left-hand axle are reversely threaded. To remove front wheels, unscrew brass cap *C*; and by means of a hexagon wrench, unscrew adjusting nut *A*, but do not alter the position of set screw *B*. When replacing wheels, be sure that the ground angular surface on cone *D* is in contact with the balls. The nut *A* should be set firmly.

To adjust front wheel bearings, proceed as above; withdraw the set screw *B*; screw on the adjusting nut *A* until the adjustment is right.

Now turn off the nut *A* about one half-revolution and tighten the set screw *B*. If there is lost motion in the bearing, loosen nut *A*, back out screw *B* a little, and tighten nut *A* again. A bearing is properly adjusted only when screw *B* makes it impossible to force nut *A* on any further, and all lost motion is out of the bearing, but without being tight. Remember that one can easily put tons of useless and harmful pressure on the bearings with careless use of the wrench.

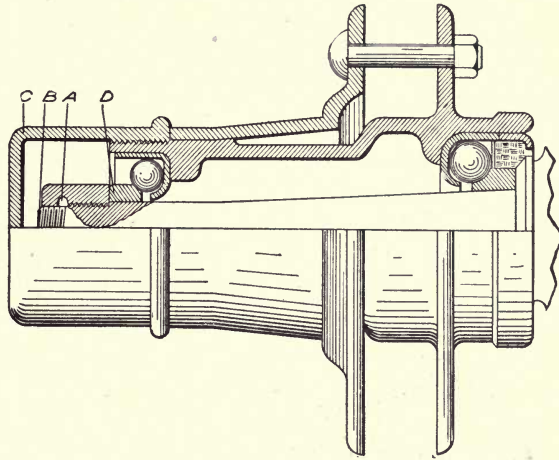

Fig. 122. Ball-Bearing Front Hub. American Ball Company, Providence, R. I.

Fig. 123 shows the Timken roller bearing as applied to the Franklin car. The part of the cut at right shows a correct adjustment, and the part at left, a faulty adjustment of this bearing. To

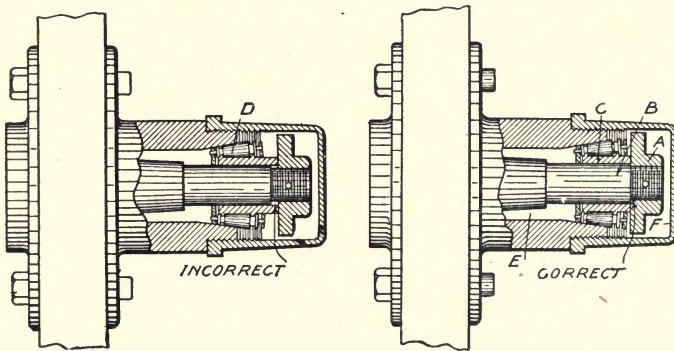

Fig. 123. Timken Roller Bearing as Used in Franklin Car.

be correct, the axle lock-nut *A* must be locked tight against the shoulder *B* on the spindle. When the nut is against this shoulder, the wheel must revolve freely without side play. In making the adjustment, if the wheel becomes tight before the nut shoulders, the

cone *C* is too long, and must be ground off on its face. If, after the nut *A* is screwed up tight against the shoulder, there is side play in the wheel, the cone *C* is too short; and the correct length must be

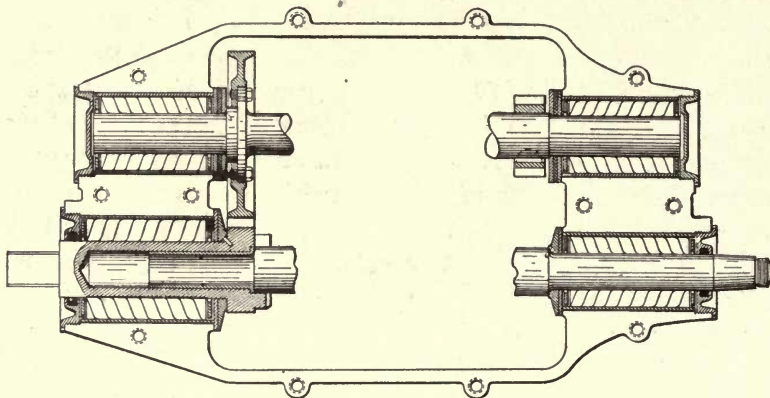

Fig. 124. Hyatt Roller Bearing as Used in Transmission Case.
Hyatt Roller Bearing Company, Harrison, N. J.

made up by placing one or more thin metal washers between *C* and *A*, until the bearing has no side play, and the nut *A* is tight against the shoulder *B*.

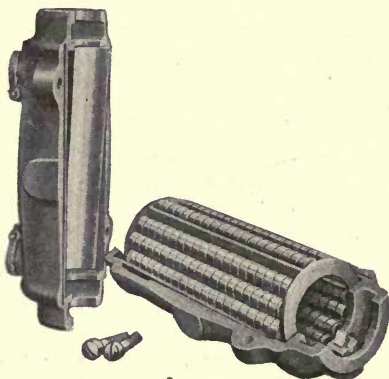

Fig. 125. Hyatt Standard Bushing
Hyatt Roller Bearing Company,
Harrison, N. J.

A bearing incorrectly adjusted, as shown in the left part of the cut, will act as follows: As the wheel revolves forward, friction is exerted by the cone *C* upon the nut *A*, causing it to screw in toward the shoulder. This forces the cone *C* up on the spindle, and jams the rollers *D* so that they will break and thus destroy the bearing.

Fig. 124 shows the Hyatt roller bearing as applied to a transmission gear case; and Fig. 125 shows a Hyatt standard shaft-box. Bearings of this type are very generally used in transmission cases and also in rear axles. They have the advantage of not requiring as much attention as plain bearings, in the way of lubrication; also the advantage of flexibility, enabling them at all times to present a bearing

along the entire length, resulting in a uniform distribution of load. Fig. 126 shows an annular ball bearing; and Fig. 127 shows how annular ball bearings are used on the crank-shaft in the Corbin car. The annular type of ball bearing is displacing the plain ball bearing, as the caging of the balls results in a minimizing of wear, making them bearings that do not require any adjustment.

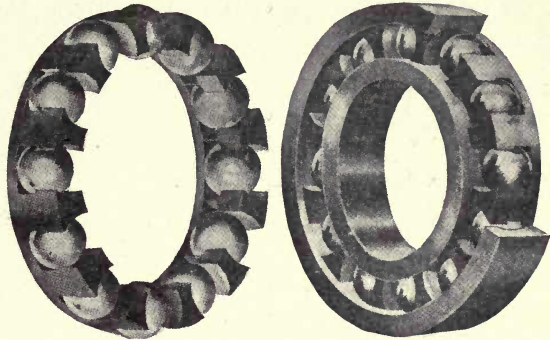

Fig. 126. Annular Ball Bearing.
Silent Type with Cage Spacer.
Standard Roller Bearing Company, Philadelphia, Pa.

WHAT TO DO TO A NEW CAR

The first thing to do is to see that oil is provided at all parts where one piece moves on another. Next remove the plug or screw top of water tank, insert a funnel, and fill with clean water. In freezing weather, some anti-freezing solution must be used. There are various such solutions on the market, some of them consisting

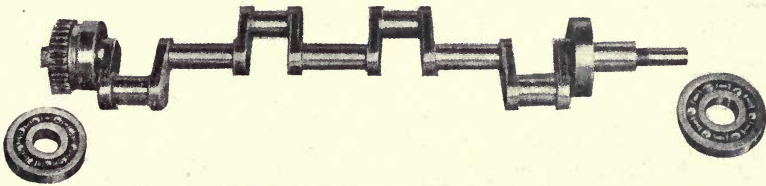

Fig. 127. Annular Ball Bearings Applied to Crank-Shaft.
Corbin Motor Vehicle Corporation, New Britain, Conn.

of oils, and others mostly glycerine. In case there is a standpipe in the water line, with a cock at the top, open this cock to permit the entrained air to escape, being sure to close this cock again after the tank has been filled.

In case of an air-cooled engine, the above instructions in regard to water are of course unnecessary.

Next remove plug or screw-top from gasoline tank, insert a separate funnel, and fill with clean, fresh gasoline, straining it through

a screen or preferably a chamois skin in the funnel; then replace the gasoline and water-plugs or screw-tops, seeing that they are firmly but not too tightly fastened.

See that the cock in the gasoline line leading from tank to carbureter is opened, and try whether gasoline flows freely to carbureter, by pressing down the primer until gasoline flows from the carbureter. If a motor has been stopped only a short time, it will not be necessary to make use of the primer. In fact it is undesirable to use the primer when the engine is still warm, as it is likely to give too rich a mixture, and such a mixture will not explode.

See that all oil-cups are full, and that they are adjusted to feed approximately 15 drops per minute.

See that the transmission is provided with a good supply of heavy oil. This will require attention about once a week. In cold weather a lighter oil will be required here than in warm weather.

TO START THE ENGINE

First, disengage the clutches.

Second, put on the brakes.

Third, open the throttle slightly.

Fourth, turn the switch handle to the "On" position.

Fifth, push the spark-lever away back to its point of greatest retardation or lateness.

Sixth, when the engine is cool, it may sometimes be necessary to prime the carbureter slightly by lifting the carbureter float-needle. This is provided for in different ways in different cars and different carbureters. In some cases a rod is made to extend from the carbureter to some convenient point, such as the floor or dash or side of the car, this rod being so arranged that by pushing it the float-valve of the carbureter is opened. Do not prime too much, as you are likely to get too much gasoline at the start; and the only remedy for this is the tiresome process of repeatedly cranking until all of the too rich mixture has been pumped through your engine.

Seventh, turn the crank clockwise, pulling upwards with a quick, sharp pull. *Never push downward.* The reason for this is that if the spark is accidentally advanced, the charge may explode before dead center, and kick backwards, resulting in the straining or breaking of the operator's arm.

Make sure that spark lever is away back, that switch is turned on, and that you can hear the vibrator buzz every time the engine goes over compression. A weak battery will cause faint buzzing.

Failure to Start. Should the engine not start at a few turns of the crank, it is of no use to work one's self tired keeping on cranking. It is best to see whether the batteries have been switched on, whether the gasoline is turned on, and if the ignition is at the right point. It may be that the carbureter is flooded, delivering too rich a mixture. In this case, considerable cranking will be necessary in order to empty the engine of the excess of gasoline, the supply being shut off during this cranking.

Other possible causes of failure to start are a sooty spark-plug or dirty commutator. Note whether the spark-coil on the dash buzzes during the cranking. If so, it indicates that the ignition coil and connections are not at fault. More likely the reason will be that the spark-plugs are dirty or sooty. Remove the plugs, and insert new ones, which should always be kept on hand. The plugs removed can readily be cleaned and used in their turn for replacement, if the plugs in use become fouled. Excessive cold, or water in the gasoline, or faulty compression, are possible causes.

The carbureter may be empty. There may be dirt in the pipes or carbureter. Gasoline in the carbureter may be stale. Drain and clean the carbureter, and give it a charge of fresh gasoline. The valves may be gummy and need cleaning. For instructions regarding carbureters, see pages 55 and 61.

The springs of the inlet valves may be too strong and may need loosening. For instructions in regard to valves, see page 56.

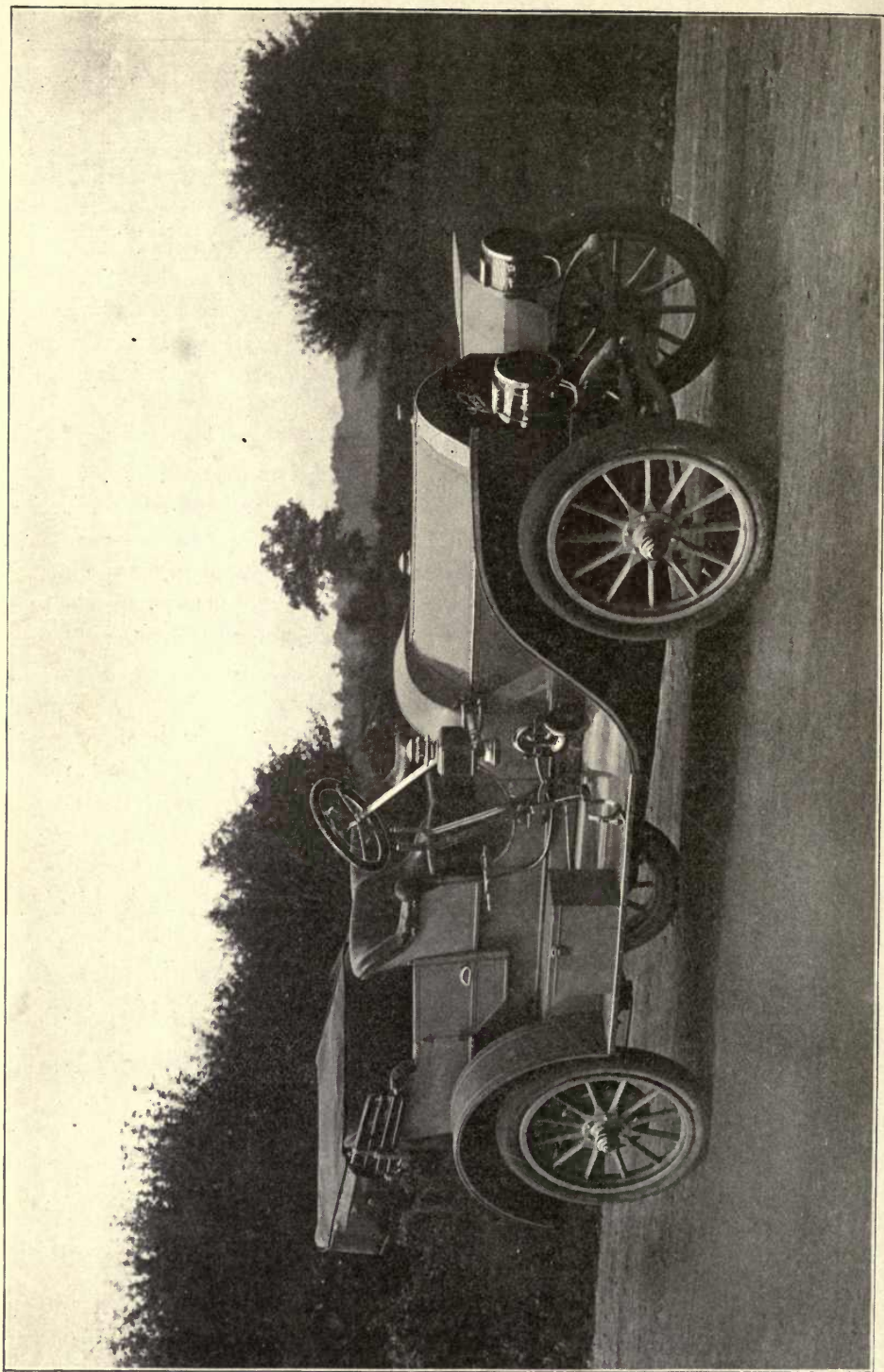

TONNEAUETTE, MODEL O.
Knox Automobile Company, Springfield, Mass.

AUTOMOBILES

PART III

SUGGESTIONS FOR OPERATING ENGINE

The speed of the engine is controlled by either or both of two methods. One of these methods is by means of the *throttle rod*. The operation of this rod increases or decreases the size of the opening into the cylinder through which the explosive mixture of air and gasoline must pass, thereby increasing or decreasing the amount of the charge, which has a corresponding effect on the speed and power of the car. Under the heading of "Carbureters" will be found description of further speed-control as accomplished by adjusting the amount of the charge, and by adjusting also the relative amount of air in the mixture.

The other method of controlling the speed and power of the engine is to change the *time of igniting* the compressed charge of gasoline and air. Three points should be remembered in connection with the timing of ignition:

1. The spark-lever, in starting, must be as far back as possible in order to give a late spark and avoid an explosion that will throw the crank in a reverse direction.

2. The faster the engine runs, the further forward the spark lever may be placed, giving an earlier spark.

3. When the engine is slowed down on a hill or a bad road, it will pull better and is less liable to be stopped by an overload if the spark-lever is pushed further back than at full speed. To keep the spark-lever just as far forward as possible without making the engine pound or jerk, means a greater amount of power for a given amount of gasoline.

Be careful not to throw in the engine power all at once. This is very damaging to tires as well as to engine.

Loss of Power in Engine. An engine may apparently be running all right, and there still may be absence or loss of power. This

condition is likely to be caused by leaky compression, for one thing. If caused at the exhaust or inlet valves, the valves will have to be re-ground. The remedy for poor compression is to stop the leaks, which will be found to be either past the valves or past the piston-rings. In the case of the valves, they can be made tight by re-grinding as elsewhere described. In the case of the piston-rings or piston scoring, the remedy may be either new piston-rings or re-boring and re-grinding of the cylinder or cylinders. Insufficient oil, or running the engine on a too much retarded spark, are also the causes of loss of power. Another cause may be that in attempting to make the engine absolutely noiseless, the cam movement may have been designed or altered so as to do away with clicking at the sacrifice of prompt valve action.

Misfiring due to improper mixture—namely, too much gasoline or too much air—will cause loss of power. Weak batteries will also cause irregular firing and loss of power, accompanied by considerable noise when the explosions do occur. A reserve supply of batteries should always be kept in the battery box. Loose connections or short circuits will also cause misfiring. All connections should be so tight that no vibrations of the car will loosen them. At the time of tightening connections, they should be perfectly bright and clean.

If a sudden break occurs in the spark-plug or wire, the trouble can usually be located. An intermittent short circuit will cause a sluggish and irregular ignition, and is harder to find. In this case a careful inspection of all wires needs to be made, to see that there is no abrasion of the insulation. It sometimes happens that a wire is broken inside the insulation. The break may be located by very slightly bending the wire at very short intervals.

A pocket voltmeter is used in locating short circuits. The voltage should be the same at all points of the circuit. If the voltage drops, it is a sign of leakage or a short circuit.

Other possible causes of sluggishness or loss of power are:

Dirt or water in the carbureter, which should be drained and cleaned.

The gasoline supply-pipe may be choked.

The gasoline may be stale.

There may be a partial vacuum in the gasoline tank through lack of an air-inlet. The remedy for this is to loosen the plug used for filling.

Valves may be dirty.

Valve spring may be weak.

Loss of power may be caused by a slipping clutch. If clutch is of the leather-faced type, the remedy is to clean the clutch with gasoline and apply castor oil at night.

Racing of Engine. This is apt to occur if the spark has been advanced too far and the engine accelerated too much for low speed. Another cause is that the clutch may be slipping, thus releasing the load.

Lack of Speed in Engine. When the engine lacks speed, it is likely that the valves do not open or close at the proper time. The lifters and connected parts wear in time. The valve movement then needs readjustment; that is, it needs readjustment between valves and lifters or cams. Loss in compression and proper spark will also affect speed. If the explosive charge is ignited just at the moment the engine is on dead center, the fullest force of the explosion and consequently highest speed are obtained. Naturally the engine must have some momentum before the spark can be used at this position; and failure to have the spark occur sufficiently early prevents full realization of speed.

Engine Stopping Completely. Valve in gasoline line may be loose, or may even have turned so as to be completely turned off. Gasoline may be all out. Battery may be exhausted. A wire may be disconnected or broken. There may be water in the carbureter. Valves may be broken. Spark-plugs may be broken. Connecting rod may be broken.

Knocking of Engine. The engine will knock if the ignition has been advanced too much; also if the engine is overheated. Want of lubrication, or poor oil, will cause knocking. Water in the cylinder will cause knocking. This indicates that there is a leak of jacket water into the inside of the cylinder. If connecting-rod bearings are down, engine will knock. Knocking in engines is also often caused by the carbureter flooding while the car is in motion; hence one place to test for improper adjustments with a knocking engine is the needle-valve and float-lever in the carbureter, as described in detail under "Carbureters."

Weak Batteries. Weak batteries are apt to deceive the operator, as they gain strength after a rest; and though the engine is apt

to start off smoothly, after a while there will be irregular action and missing of explosions. Naturally the first inspection would concern the spark-plugs, to see that they are clean. The next investigation would relate to the wiring, to see that all the connections are tight and that there is no break in the wires. If these are all found in good condition, it is very likely that the trouble is with the batteries.

It is customary to have two sets of dry cells, using only one set until they show signs of weakening, when the other set should be thrown into circuit. This is a temporary expedient, and should be followed by a replacing of the weakest dry cells by new ones.

A small ammeter is an inexpensive instrument, and very desirable for testing the usefulness or worthlessness of an individual cell. If the current is as low as one-half the rated output of the cell, the cell should be discarded.

A low temperature will always cut down the efficiency of dry cells temporarily, and in cold weather it is often necessary to put both sets into circuit. If they still show signs of weakening, they should be thoroughly warmed, and the higher temperature will temporarily raise the efficiency.

It is best to use generating batteries specially constructed for automobile use. There are a number of good makes on the market. Such cells are usually better encased, and are built to withstand jarring much better than the cheaper cells made for house wiring.

The usual voltage required to give a satisfactory spark for ignition is from six to ten volts, six being the usual voltage for jump-sparks, which predominate in automobile engines. Somewhat higher voltage is required for gasoline-engine igniting by the make-and-break system.

Voltage means simply pressure; *ampere-hours* means the capacity. For greater mileage, do not increase the voltage, but provide greater battery capacity—that is, greater ampere-hours.

The usual life of a battery of twenty ampere-hours capacity is 300 miles in a four-cylinder engine, 500 miles with a two-cylinder engine, and 800 miles with a single-cylinder engine.

Noise. In a gasoline car, there is bound to be some sound present, owing to the explosions of the engine and the working of the gears or chains. The latter should never be more than a hum, and at that it should not be a loud or annoying hum. Correctly cut

gears in proper alignment will make but very little sound. If there is grating or rattling, there is something wrong.

The clicking of valves cannot be done away with. It is essential that valves seat quickly, and not gradually; and this prompt action means a sharp click.

A clatter or grind in the gear-box indicates that the pinions are loose.

An overheated engine will rattle.

Noise caused by firing in the carbureter is due to a late spark or weak mixture.

Noise caused by explosions in the muffler is due to too rich a mixture.

Loose fenders cause an annoying rattle, which is very easily disposed of if the method of attachment is one that permits of the use of washers or lock-nuts or some means of really tight and permanent fastening. The method of attachment of fenders, in many otherwise high-grade cars, is not looked after in a manner that will obviate annoyance due to rattling.

A popping noise indicates bad carburetion. The carbureter may be flooded or have insufficient supply. The inlet valve may be sticking open, or its spring may be weak.

A metallic or puffing noise indicates that a joint in the exhaust pipes has given out. See also under the heading "Knocking of Engine."

Explosions. These are traceable to short circuits; to exhausted batteries; to one or more cylinders not working, because of lack of ignition in them resulting from broken or sooty plugs or other local troubles in one of the cylinders, or from faulty carburetion.

Escaping Water. If there is dropping of water, or a pool of water is noticed after car has stood a while, it is a sign of a burst water-pipe or loose connections.

Back-Firing. By *back-firing* of the engine is meant that when the explosion takes place, the engine fly-wheel is rotated in the opposite direction from that in which it should rotate. It is caused by a spark or ignition taking place too early in the stroke. After the engine is run some time, the spark is made to come earlier in the stroke, or is *retarded*, until ignition takes place just before the engine is on dead center, the momentum of the engine carrying it forward.

If the engine is at rest, however, and the spark is in a retarded position, the tendency will be to drive the engine backward; and even an experienced hand at cranking is likely not to be quick enough to avoid a sprained wrist, a dislocated arm, or a blow in the face from the crank. In turning the crank, force of pressure should be exerted only in pulling up the handle, and not in pushing it down. In this way, should the handle violently pull itself away, it can do no harm as it will simply tend to straighten out the fingers that are engaged in the upward pull.

Smoke. The causes of smoke and odor are too much oil or too much gasoline. Where a crank-case splash is used for oiling, the best way to prevent an excess of oil getting into the cylinder is by having one or more extra rings on the piston below the lower ring, this extra ring scraping off the surplus oil. The color of smoke due to oil is blue. Corrosion will also cause smoke, and should be remedied as indicated under the heading "Corrosion," by cleaning with kerosene.

Smoke due to too much gasoline in the mixture, is black and of strong odor.

Skidding. Skidding or sliding of motor-cars on wet, oily streets is sometimes very annoying to a novice or beginner in the new field of motoring. And while the results are sometimes very serious where the streets are crowded and traffic is heavy, it bothers the experienced driver but little, since he has studied his car as a sailor learns his ship at sea, and the moment it occurs he knows the best way to favor his car under this unpleasant situation.

Skidding, as we all know, is due chiefly to poor traction. If we had dry streets all months in the year, this unpleasant experience would hardly befall us; but until the wheel is brought into use that has the same resilience as rubber and has the same good traction in either dry or wet weather, it will be up to the driver as to the best way to avoid the skidding of his car in bad weather.

As we drive down an asphalt boulevard on a wet day and see a car up against the curbing, with a broken wheel, the first thing that occurs to us to say is: "Well, that fellow had to stop a little sooner than he expected." The chances are that the driver of the car was running faster than one should on a wet day; and at the moment when he decided that he had better bring his car to a stop, he applied the

emergency brake, locking the rear wheels, whereupon the weight of the car carried him from the graded part of the street into the curb.

Two years ago, such accidents were of more frequent occurrence than they are to-day. This is chiefly due to the fact that the up-to-date motor-car is being equipped with what we term an equalizing wire or bar whereby the two rear brakes will get the same tension, and a car will slide straight if the street or road is level. In the case of the old brake, where it was necessary to jack up the rear wheels of the car, and adjust brakes to what was deemed about right, nine out of ten times one brake was tighter than the other. Such a condition of the brakes will skid a car very quickly, for the car will always skid to the side on which the brake is tightest, and will almost always turn completely around.

The conservative driver on a wet, muddy day is constantly figuring, so to say, one minute "ahead of the game"—which is a long time in motoring. He is thinking what the driver of the car ahead is going to do, and whether he is going to cut him off at the corner. Or it may be that he sees a rig approaching on a cross-street. Will it be past by the time he reaches the corner? If not, he will check the speed of his car so that the rig will have gone by, leaving the roadway clear. A good policy on a wet day is to keep one's car as near the center of the street as possible, still favoring with the right of way, as much as possible, the driver coming in the opposite direction; and to avoid as far as possible any use of the brakes.

It is bad policy to use the brakes on a wet clay hill, for this is the quickest way possible to put a car in the ditch. Throttle the motor down low; if necessary, put in the low gear, and let the weight of the car drag on the motor. On the road, should the car start skidding the rear wheels into the ditch, just drop back a speed lower on the shifting lever, keep the motor running about the same number of revolutions, and cramp the front wheels quickly in the opposite direction. The car may slew to the other side; if so, cramp the front wheels again in the same manner. This may take a little practice on the part of a beginner, but will keep the car in the road. Should the front wheels act as if beyond control, on account of skidding, just draw the clutch, or, in other words, disengage the engine so that there will be no power transmitted to the rear axle. Keep

out the clutch until control of the front wheels is regained—which will be before long. Never be afraid of the car, and learn to favor the engine under all conditions.

Skidding, on the other hand, has done a great deal for road racing during the past few years, in negotiating bad turns in getting a high speed average. Bad turns on a course are easily made by the practiced professional road-driver at a high rate of speed, through the knack of skidding. M. Laucia, for example—one of the greatest drivers in the world—will run onto a right-angled corner at the rate of 65 to 75 miles per hour; and at a certain spot which he has marked in his mind (as he does every bad point in a course), he will ground his magnets by means of a ground wire and button connected to his steering wheel (this taking place about 100 yards from the turn); will then draw the clutch; and, about 25 feet from the corner, will apply his positive brake (which locks his rear wheels) and turn his front wheels to a slight angle in the direction he wishes to go—all in a second. You will see an awful cloud of dust arising; the weight of his huge piece of racing machinery has skidded; his rear wheels have swung around just a quarter; he then drops back to a lower gear on his speed sector, lets in his clutch, and is off like a shot from a cannon. In the 1907 Vanderbilt race, Laucia had his rear brakes so arranged that he could lock either wheel, or both. This helped him wonderfully in making bad turns, as he used his steering wheel only to steady his car, while his clutch and new brake arrangement (his original) skidded his car at the corners.

Going down Steep Hills. In going down a long, steep hill, the wear on the brakes would be very great if they were used entirely to hold the car down to a safe speed. In going down hill, one can usually depend on the braking effect of running the engine without power, thus having the gear drive the engine and opposing a load to the downward pull of gravity. By throwing the engine into gear, you get a bigger brake effect. The only danger is the possibility of getting the engine beyond its proper speed. A good many people do not believe in pulling the clutch when operating the brake. If the brake does not disengage the clutch, it would put a strain on the engine if the brake were applied while the engine was in gear. Some makers are now arranging details so that the regular brake operates the clutch, and the second or emergency brake does not.

If the hill is not long or steep enough to demand the use of the engine compression as a brake, one can use the regular and emergency brakes alternately, thus removing the strain and giving each an opportunity to cool off.

When using the engine compression as a brake, one should not run far without shutting off the gasoline. It is of course necessary to throw the current and gasoline on before the end of the hill is reached, so as to avoid the necessity of getting out and cranking to start.

On the Road. After making a run of a certain number of miles the car should be subjected to the following inspection:

Examine the radiator to see that it is not unduly hot, and that it contains sufficient supply of water; examine oil-pump box to see that it is well supplied with oil; inspect gasoline tank to see that you have sufficient gasoline to reach your destination; note whether oil is leaking from your engine casing, gear casing, or rear-axle housing; see that no gasoline is leaking from your machine. If a gasoline leak occurs, have it fixed promptly; do not permit a leak from this source an instant longer than may be necessary, as it may result in a fire, which in turn may cause the destruction of your car and endanger the lives of its occupants. Examine rear-axle bearings, and see that they are not becoming heated. The rear-axle housing will be slightly warm, especially if you have been running on high gear. This will do no harm, as it is simply due to the "churning" of the oil. Feel front hubs to see that they are not heating. Examine tires carefully, and note their condition.

The chances are that nothing whatever will be found wrong with a machine, if thoroughly tested before starting.

Cleaning and Washing. It is very essential to clean the motor regularly, and to keep all the bright parts well polished. Touring cars cover so much more ground than horse-drawn vehicles that they are apt to accumulate a great deal more mud and dirt, and the entire car therefore should be thoroughly cleaned and washed frequently. It is important to use a slow stream from the stable hose, so that the mud will be soaked off and the finish uninjured, and no water spattered in through the bonnet. The body should always be dried with chamois skin; and if, after washing, it can be run outdoors in the sunshine, the finish will tend to harden and brighten.

CARE OF TIRES

Probably the chief cause of the wearing-out of tires is that they are not kept sufficiently inflated. It is not sufficient that the tire shows no depression whatever when standing on a hard surface under

full load, but the tire should be inflated to the full standard pressure corresponding to its diameter. The tire tube, properly inflated, is somewhat longer in its vertical than in its horizontal diameter, as shown in *A*, Fig. 128. A tire insufficiently inflated as shown in *B*,

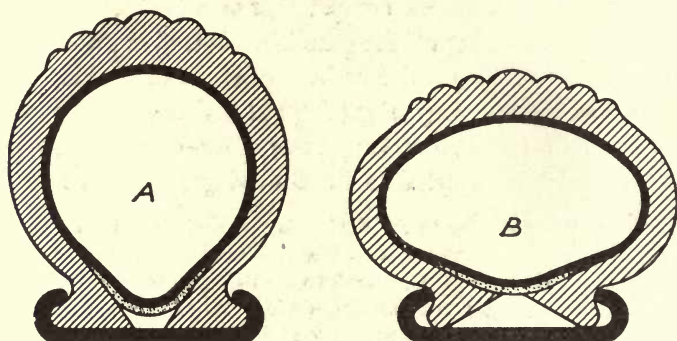

Fig. 128. Tire Properly Inflated (*A*) and Improperly Inflated (*B*).

Fig. 128, is subjected to the inner pressure of the rim. The following is a list of pressures to which tires of various diameters should be inflated:

TIRE INFLATION

DIAMETER OF TIRE	PRESSURE
2½ inches.....	45 pounds
3 ".....	50 "
3½ ".....	60 "
4 ".....	70 "
4½ ".....	80 "
5 ".....	90 "

Every automobile owner should have a tire pressure-gauge; and this should be attached to the valve, not to the pump. The pointer on the gauge oscillates with each stroke of the pump; the pressure in the tire, however, is indicated by the pointer when it is at rest. In using a pump, take long strokes, for in pumping short strokes much of the pressure accumulated in the pump is not transferred to the tire. If a car is in daily use, it can be left standing on the tires; but they should be left inflated. If the car is to remain for some weeks without being used, it should be jacked up and the tires deflated to remove tension. They should be kept free from dampness, for that is very injurious. Corners must be turned at slow speed. Do not drive in street-car tracks, as this rapidly wears out tires. Apply brakes

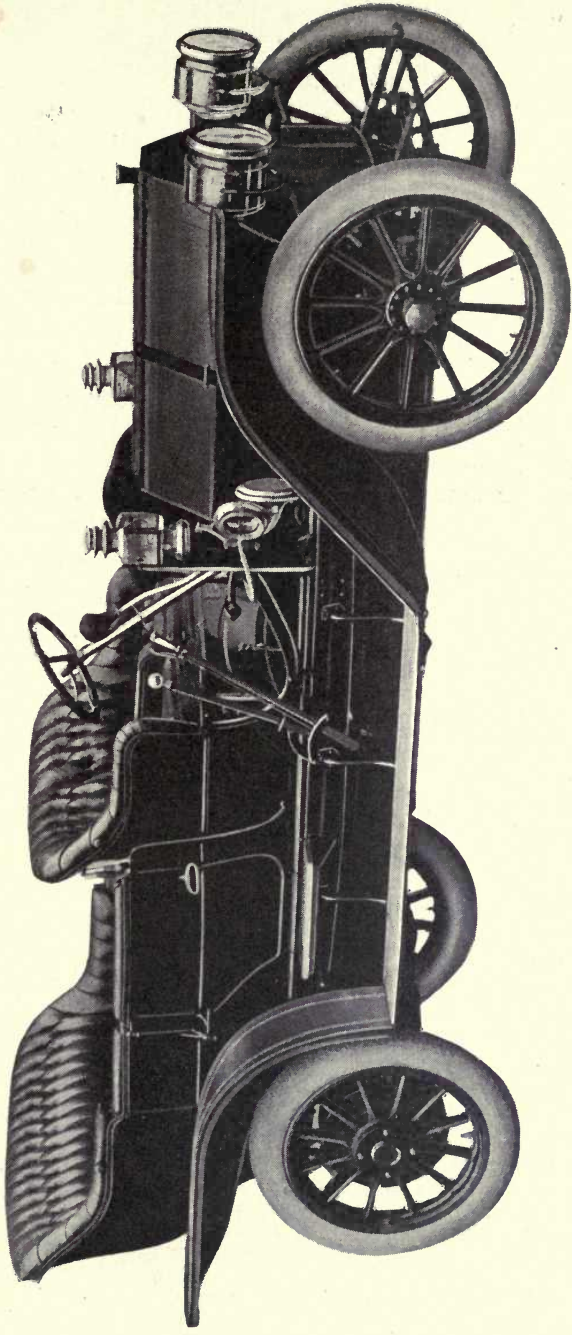

TOURING CAR, MODEL 50.
Nordyke & Marmon Company, Indianapolis, Ind.

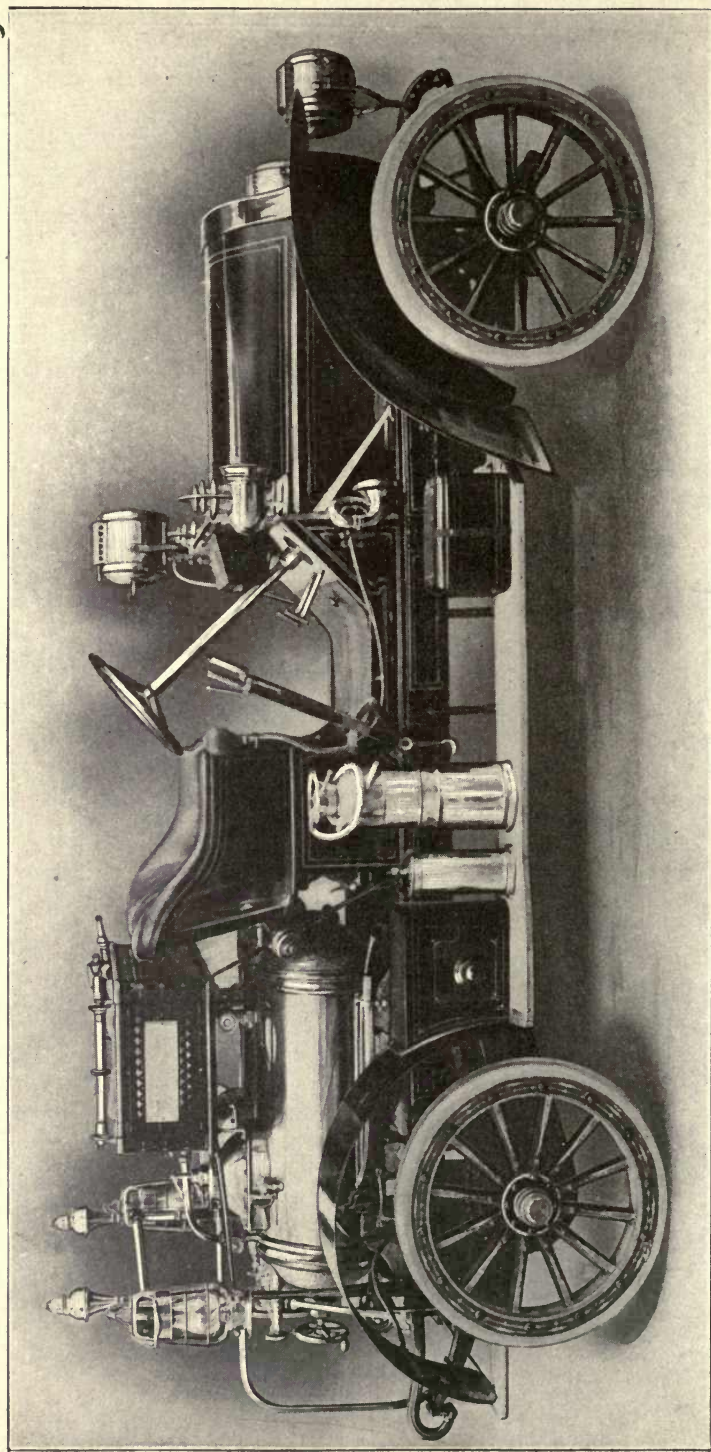

AUTOMOBILE CHEMICAL FIRE ENGINE.
Knox Automobile Company, Springfield, Mass.

gradually, as their sudden application locks the wheels and causes the tires to slide. Do not let oil come in contact with tires, because it disintegrates rubber and destroys its elasticity. Should any oil get on the tires, remove it at once with gasoline. Examine the rims occasionally; and if they are becoming rusty, rub them down with emery cloth and apply white lead and varnish. If an outer case is badly cut, it should be bound temporarily with tire tape or a piece of leather.

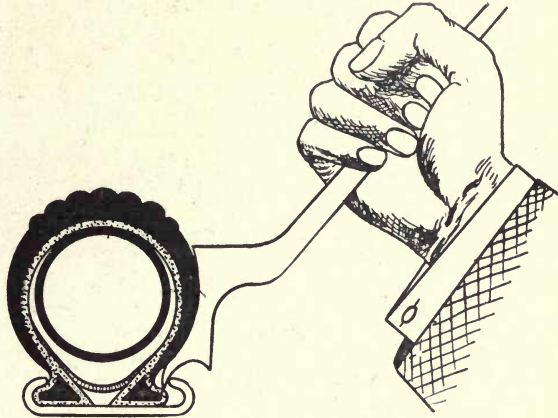

Fig. 129. Use of Large Tool in Removing Tire.

Each size tire is designed to carry a certain weight, as shown in the following table:

WEIGHTS CARRIED BY TIRES OF DIFFERENT SIZES	
SIZE OF TIRE	WEIGHT CARRIED
2½-inch tires, all diameters,	225 pounds per wheel
3-inch tires, all diameters,	350 " " "
3½ by 28-inch tires,	400 " " "
30-inch "	450 " " "
32-inch "	555 " " "
34-inch "	600 " " "
36-inch "	600 " " "
4 by 30-inch "	550 " " "
32-inch "	650 " " "
34-inch "	700 " " "
36-inch "	750 " " "
4½ by 32-inch "	700 " " "
34-inch "	800 " " "
36-inch "	900 " " "

To determine the weight resting on each wheel, the front end of the car should be run onto scales to determine the front-axle weight. One-half of this will represent the weight per front wheel. The same process gives the weight per rear wheel.

32
7-10-1910

To Remove Tire from Rim. The following instructions are to a considerable extent those given by the Gormully & Jeffery (G. & J.) Tire Company, but with slight modifications apply to any make:

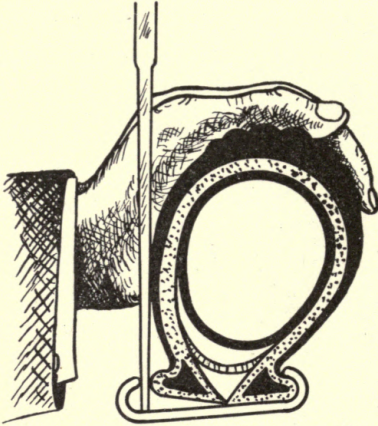

Fig. 130.

Use of Small Tool in Removing Tire from Rim.

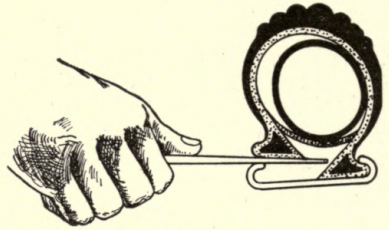

Fig. 131.

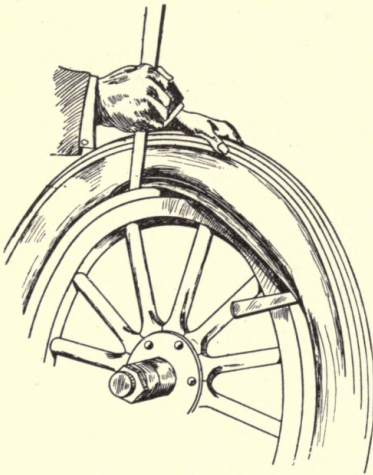

Fig. 132. Removing a Tire.

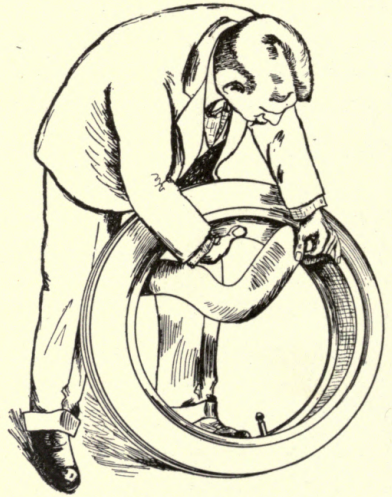

Fig. 133. Partially Removing Inner Tube.

With large tire tool, as shown in Fig. 129, push the end of the tire free from the rim. Pry up the edge of the tire case with small, straight tool (see Fig. 130). Push tool straight in underneath the tire (see Fig. 131). Leaving the small tool underneath the edge of the

case, pull towards yourself (see Fig. 132). When a foot or more of the edge of the case is free from the rim, pry it over the edge of the rim; then, after about one-third of the case is released, the entire tire can be pushed off with the hands.

Finding a Puncture. If a puncture is located before removing the tube, it will be unnecessary to remove the tube from the case. The tube can be drawn down as indicated in Fig. 133. If puncture has not been located, remove tube from the case, inflate it, and pass it by your face, when you will likely feel or hear the escaping air and thus be able to locate the point of puncture.

To Repair a Puncture. Sandpaper the surface of the tube at point to be repaired. Sandpaper also the patch piece. Apply tire cement to both tube and patch, and allow each to dry separately. When dry, apply a second coat of tire cement to both tube and patch. When the second coats of cement are about dry, press the patch down firmly. The patch will hold better if given time to get almost dry before pressing it down. If you attempt to hurry the repair, there is danger of the patch coming loose. Before putting the tube into the case, investigate the case, and see that no needle, tack, or nail is left remaining in it.

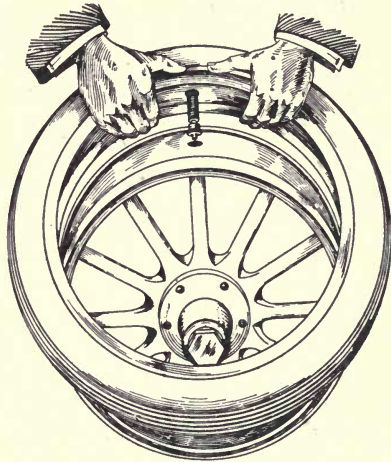

Fig. 134. Returning Tire to Rim.

Returning Tire to the Rim. Slightly inflate inner tube, and push it back into the case as shown in Fig. 133. Then take the case with inner tube in it, and push valve-stem through valve-hole in rim, as shown in Fig. 134. Fig. 135 shows how the inner edge of the case is sprung back into place with the large tire tool. Fig. 136 shows how the second or outer edge of the case is pushed into place. Screw down the valve-nut so as to hold down the tire at this point. Place a small, flat tool at each side of the valve underneath the edge, to prevent the edge from slipping out; and with the large tire tool, pull towards you.

Before inflating, look around the tire on each side to see that the edges are properly seated.

CARE AND OPERATION OF ELECTRIC VEHICLES

The Volt-Ammeter. The motive power of the electric car is

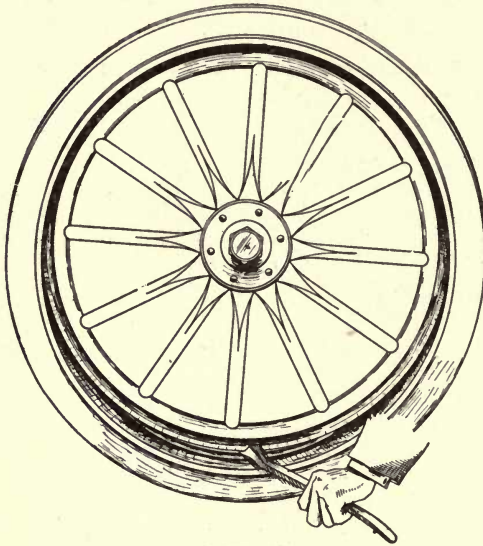

Fig. 135.

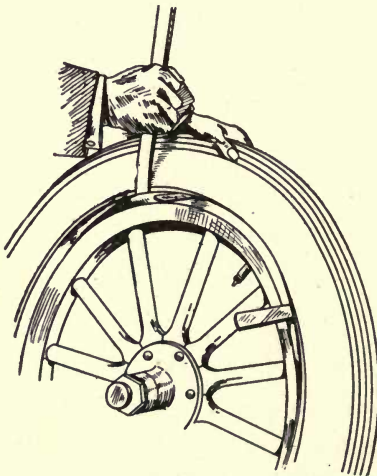

Fig. 136.

Final Adjustments in Returning Tire to Rim.

the *storage battery*. The amount of power available is registered by the *volt-ammeter*, Fig. 137. This instrument, as commonly used on electric cars, consists of a voltmeter and an ammeter mounted on a single base and enclosed in a case, with their graduated scales adjoining each other. The purpose of the volt-ammeter is to keep the driver posted as to how much electric power he has available.

Before starting out with an electric vehicle, the driver should know how to read the meter correctly, and he should keep in mind the amount of electric power at his command.

When the battery is fully charged, and after the charging current has been cut off, this meter should show 2.2 volts per cell. Thus a 24-cell battery should show about 53 volts; a 30-cell battery,

66 volts. Batteries should not be discharged below 1.75 volts per cell. Thus, when a meter in a vehicle containing 24 cells of battery shows about 42 volts when running at full speed on a hard, level road, the battery is discharged. If the vehicle is driven after this point is reached, it is at the risk of damaging the battery.

The ammeter shows the amount of current being used by the vehicle at any time when it is running. On hard, level roads this will range from 18 to 24 amperes when running at second speed. The more difficult the road, the more current it will take to run the vehicle.

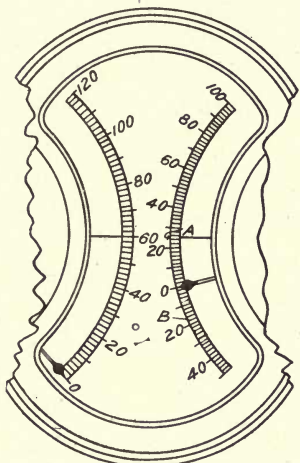

Fig. 137. Volt-Ammeter Face as Usually Graduated.

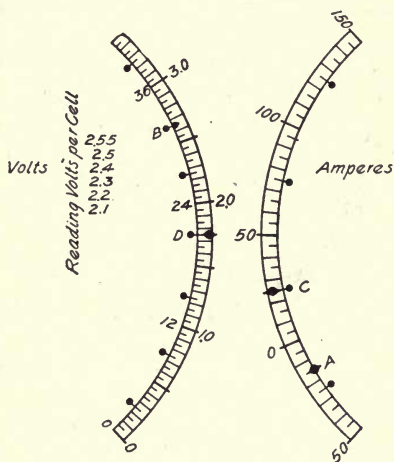

Fig. 138. Volt-Ammeter Face Graduated to Show Voltage per Cell.

If the driver watches his volt-ammeter, there is no reason for his ever being *stalled* without any means for recharging his batteries.

It should be remembered that the gauge of the condition of the batteries is the voltage per cell. This is obtained by dividing the voltmeter reading by the number of cells, the voltage reading being taken when the car is doing normal work. The voltage reading when no work is being done is no gauge.

Some makes of volt-ammeters have the calibrations numbered so as to indicate the total voltage not only of the battery, but also of the cell. This type of instrument is shown in Fig. 138. The smaller figures on the left side of the meter indicate total voltage of the battery. Thus, if we have 12 cells of battery, when the pointer indicates 24 volts, the reading is 2 volts per cell. With this type of instru-

ment, one can observe closer voltage reading than when the total voltage only is indicated. The point *B*, indicated by the small arrow, is at a point indicating 2.65 volts per cell, which indicates the highest point at which a 12-cell battery should be charged, when ammeter needle is at *A* on the ampere side of the instrument. The point *D* shows the point at which the battery will be discharged when the ampere needle is at *C*.

Controller. In starting a car, the first thing to do is to see that the controller handle is at the "Off" position. This is the first step, and should be noted before inserting the key which closes the circuit. It might happen that the controller handle had been moved to some running notch by some curious or mischievous person. In this event the car would start as soon as the key was inserted, and might cause an accident.

Pulling out the key also affords a means of stopping the car in case the controller handle should stick, although such an occurrence is rare.

In starting the car, do not advance the controller handle beyond the first notch. As soon as the vehicle has gained a little momentum, the handle may be advanced another notch. The handle should never be allowed to remain between notches, as this is likely to cause arcing in the controller.

In stopping or reversing, the lever should be thrown quickly back to the "off" position. To reverse, the reverse switch is thrown "On," and the controller handle advanced to the first notch. The beginner will find it a little difficult at first to steer on the reverse, and should have his foot on the brake and be ready to throw the controller handle to the "Off" position. Unless an unusual emergency demands it, never reverse a vehicle while it is moving forward. And under no circumstances change again while it is moving backward.

Driving an Electric Vehicle. First attempts at steering should not be made on a crowded street or at full speed. Turn the corners at slow speed, especially if the streets are wet and slippery. Do not grip steering or controlling levers tightly. A firm but relaxed hold is the correct one. The bell is operated by a push-button, sometimes located on the floor and operated by the foot, and sometimes in the handle of the steering lever.

The bell should be rung lightly when turning from one street

to another, when approaching a crossing, or when obliged to stop suddenly in a crowded street.

In great emergencies a motor may be reversed at first speed; but this method of stopping should not be used until all other means fail. Brakes should be used as rarely as possible, and current should be cut off before applying them. A good driver will always be economical with his power, and with care will be able to get from eight to twelve miles more with one charge of the battery than one who does not save at every opportunity.

Such little economies as turning on the motor light only when necessary, coasting whenever practicable, and using a second speed instead of the high speed, will all help in prolonging the amount of run to be had from one charge.

Care of Motor. The commutator should be kept clean, using an oily felt. If the felt will not clean, sandpaper may be used, but must always be followed by rubbing with the felt. Great care must be exercised not to leave particles of sand between the brush and the holder, as this will cause charring of the commutator. Brushes should be thoroughly cleaned, and no dirt or sand allowed to get between the brush and the holder, which prevents free movement of the brush, causing sparking and blackening. Tension on the brushes must be sufficient to give good contact with the commutator. In most automobile motors, brush-holders are stationary, being

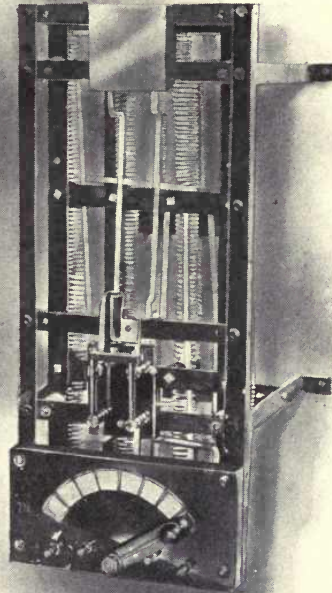

Fig. 139. Rheostat for Reducing Line Voltage of 220 or 110 Volts to Proper Voltage for Charging Batteries.

The Waverley Company, Indianapolis, Ind.

placed at the neutral points; and their position should not be changed.

Charging Stations. Storage batteries for electric automobiles must be charged with a direct current at a rate varying from 6 to 40 amperes. The voltage usually required varies from 65 to 110 volts, according to the number of cells in the battery. A town or locality supplying a 110-volt direct current affords the best facilities for charging

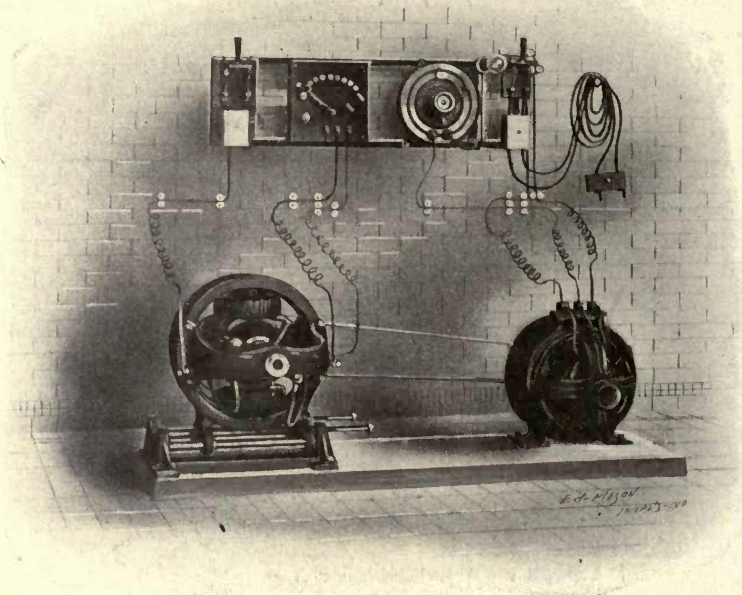

Fig. 140. A $2\frac{1}{2}$ -Horse-Power Motor-Generator Set for Reducing 500-Volt Line Current to Proper Voltage for Charging Batteries.
The Waverley Company, Indianapolis, Ind.

ing batteries. Under such conditions the only equipment necessary for charging is a rheostat introducing resistance to cut down the voltage from 110 volts to the required point (see Fig. 139). When 220-volt direct current is used, voltage may be reduced in this same manner; but with 500-volt or with alternating current, a motor-generator set is required for charging (see Figs. 140 and 141).

Where access can be had to a factory where it is practicable to drive from a shaft a small 2-horse-power generator, this arrangement will be found more economical than any other. The gasoline

engine has also been used for driving a dynamo to charge storage batteries (see Fig. 142).

The usual cost of keeping up batteries of an electric vehicle, when this care is assigned to a garage, is about \$25.00 a month for a 24-cell car, this charge including cost of charging current, care of batteries, oiling, and general up-keep. Where this work is done by

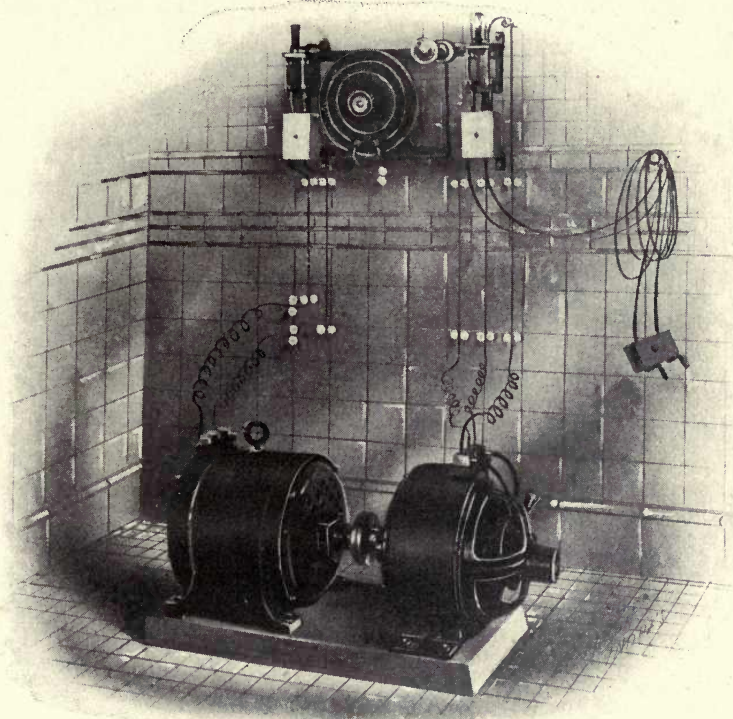

Fig. 141. A 3-Horse-Power Motor-Generator Set for Transforming Alternating Line Current to Direct Current of Proper Voltage for Charging Batteries. The Waverley Company, Indianapolis, Ind.

- the owner, cost of current alone should not exceed ten dollars per month; hence it is often more economical as well as more convenient for the owner to provide his own charging station.

Where a person desires to maintain an electric vehicle at a point remote from electric current, and where it is not convenient to obtain power for driving the charging generator from a factory line-shaft, the gasoline-engine-driven generator set for charging the storage battery is available.

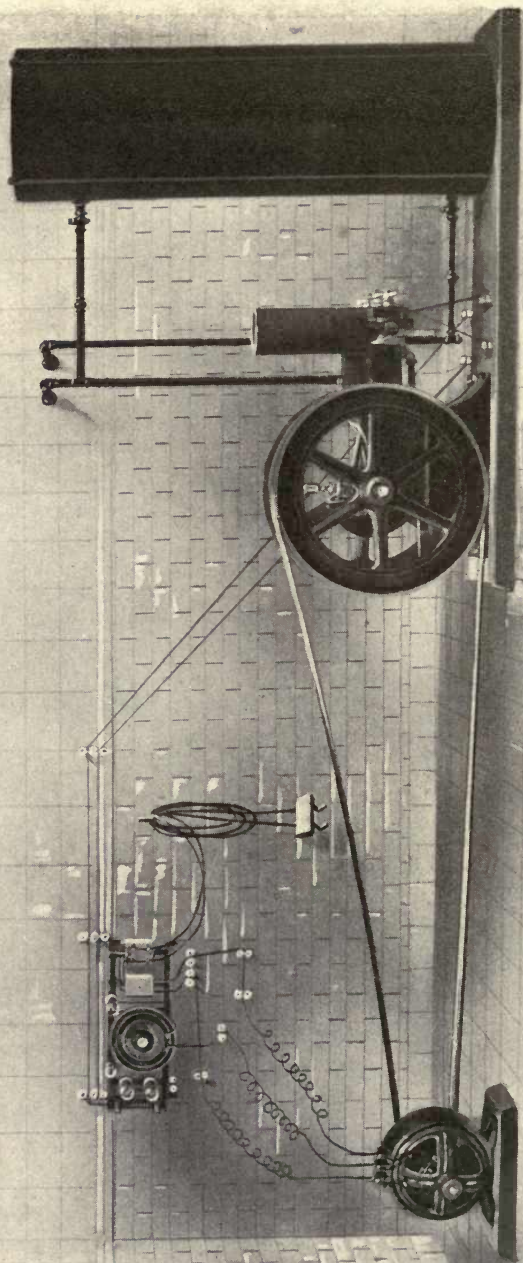

Fig. 142. Charging Generator Driven by 3-Horse-Power Gas or Gasoline Engine.

Storage Batteries for Electric Vehicles. Storage batteries usually suffer more from neglect than from any other cause, the reason being that they do not give any decidedly pronounced evidence of such neglect until it has been a matter of long standing.

The storage battery, strictly speaking, is not a device for storing electricity, but is a device in which the energy of an electric current provided from some outside source is caused to produce electrolytic decomposition to such an extent as to produce independently an electric current after the removal of the electrolyzing current. The charging current produces an electrolytic decomposition of the liquid between the plates. This liquid is usually a mixture of chemically pure sulphuric acid with distilled water, mixed until the specific gravity, when the mixture is cold, is 1.28. The mixture should always be made by adding the acid to the water, and allowing the mixture to cool thoroughly. *Never prepare the mixture by adding water to acid.* Water must be distilled and free from iron or other metallic ingredients.

On the cessation of the charging current, and the connection of the charged plates by a conductor outside the liquid, a current is produced which flows through the liquid from the plates about which the positive radicals are accumulated to the plates about which the negative radicals are accumulated, or in the opposite direction to that taken by the charging current.

When this reversal or discharging action is thoroughly effected, the cells become inactive, and will furnish no further current until again charged by the passage of a current from some external source.

Charging Storage Batteries. Before beginning to charge a battery, remove the starting plug from the car, and see that the controller handle is in the "Off" position. After making sure that the knife-switch between rheostat and outside current is open, and the rheostat handle at its extreme left, insert the charging plug into the socket for its reception (this socket is usually under one side of the vehicle body). Then close the knife-switch; and by turning the rheostat handle to the right, adjust the current to the ampere rate indicated by the battery manufacturer. This rate—to be maintained usually for about eight hours—varies from 9 amperes in a 5-plate cell having plates $4\frac{3}{4}$ by $8\frac{5}{8}$ inches, up to 26 amperes in a 13-plate cell with plates of same dimensions.

The bell must not be rung, nor the lamps turned on, while the battery is charging, as the increased voltage may cause them to burn out.

The normal charging current as required by the battery should be maintained until the battery gasses freely, and the voltage reads

2.5 to 2.6 volts per cell with charging circuit closed. When the voltage has reached 2.5 volts per cell with charging circuit closed, the charging current may be adjusted to one-half the normal charging rate, until the voltage rises to 2.6 volts per cell with charging circuit closed. It is well to charge occasionally at only one-half the normal charging rate, especially if the battery has been over-discharged.

Always remove the vent-plugs in the cells when charging the battery. Provide free circulation of air around the battery.

A battery *gases* as one approaches the end of the charge. The action is that of the electrolyte throwing off hydrogen.

Gasing is the symptom watched for in connection with the voltmeter reading when charging current is momentarily shut

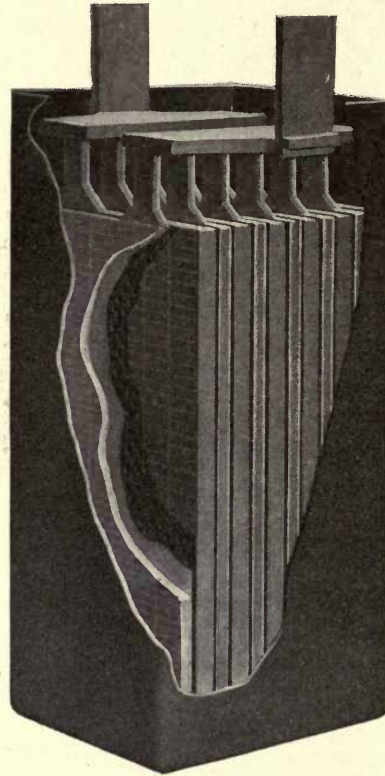

Fig. 143. Single Storage-Battery Cell. Universal Electric Storage Battery Company, Chicago, Ill.

off, to indicate that the batteries are recharged. Care should be exercised, when gasing occurs, that no flame or spark is near the batteries, as hydrogen gas is inflammable.

Be sure the electrolytic fluid is always maintained above the tops of the plates. Examine the cells frequently with this point in mind.

It is not economical to charge at a higher rate than specified as normal by the battery maker. A long-continued charge at a low

rate, $\frac{1}{2}$ to $\frac{1}{4}$ normal, is beneficial, and will increase the life of a battery.

Never allow the battery to stand discharged. Always charge immediately after using.

If it is necessary to remove the elements from the jars, do not let them stand where dust or dirt can get on them. Place them in a receptacle containing distilled water or dilute acid.

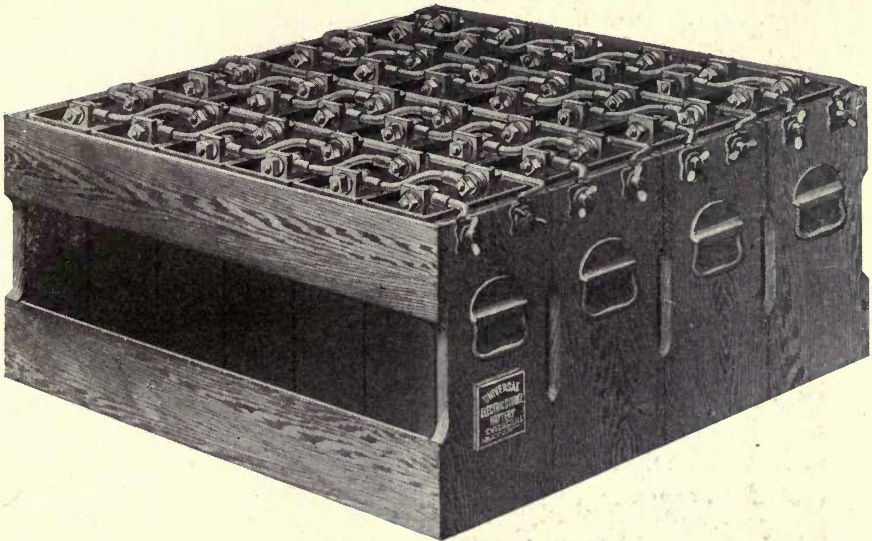

Fig. 144. Assembled Battery of 24 Cells, Bolt-Connected, Ready to Put into Car. Universal Electric Storage Battery Company, Chicago, Ill.

A battery that is not being used should be given a freshening every two weeks.

A battery that has stood unused for some time will lose a part of its charge, due to local losses in the cells. Under these circumstances the battery should be fully discharged and then recharged.

The best method of discharging when not running the vehicle, is to lay a piece of metal across the open rheostat switch, leaving the switch stand out in a horizontal position, thus discharging through the rheostat. The rate of discharge can then be adjusted as in charging.

Fig. 143 shows a single storage battery cell; and Fig. 144 a 24-cell battery set assembled and ready to put in car.

Care of Storage Batteries. The following is a list of cautions to be observed in connection with the care of storage batteries:

Keep the electrolyte at the proper height above the top of the plates.

A battery should not be excessively overcharged.

A battery should never stand completely discharged.

A battery should be kept free from deposits in the bottom of the jars.

The battery temperature should never exceed 100 degrees Fahrenheit.

Entirely discharge a battery, and then recharge it regularly once a month.

All battery connections must be kept clean and bright.

Any low cells in the battery must be located and repaired at once.

Battery compartments should be kept dry.

The electrolyte in the cells should stand from $\frac{1}{4}$ to $\frac{1}{2}$ inch above the top of the plates. All loss by evaporation should be replaced with distilled water only. Once a month the gravity of the acid in each cell should be tested, and if found to be low, electrolyte instead of water should be used to replace the loss. No information concerning the gravity of the acid can be obtained unless the battery is fully charged.

A battery may be overcharged in two ways: *First*, by charging too frequently; *second*, by charging too long at a high rate. If a battery that will run a vehicle forty miles is charged after every short trip of five or ten miles, it is charged four or five times as often as it should be. A battery should not be charged until over 50 per cent of its capacity has been exhausted. If excessively overcharged, a rapid deterioration of the plates will result.

However, keep in mind the fact that a legitimate overcharge, so called, may be given from one to three hours at a low rate about once a month, and will prove beneficial to the batteries.

An electric vehicle should never stand with the battery completely discharged. If permitted to do so, the plates of the battery are likely to sulphate, which will tend to destroy their efficiency. A low gravity of the acid, and whitish appearance of the plates, will indicate this condition. The battery may be put in good condition again by a long, low charge. A badly sulphated cell may require a charge of as much as 60 hours at low ampere rate, before being brought to proper condition. Do not be alarmed, however, if the voltage runs up higher than usual during this process. As soon as the sulphate is broken down, the battery will assume its normal condition as to voltage and the gravity of the acid.

The sediment which collects in the bottom of the jars as the battery is used, should not be allowed to reach the plates. If some of the cells show a low capacity or heat quickly in charging, cut out the low cells, remove their elements, and examine the jar to see if there is much sediment in the bottom. If so, the battery needs washing, and this should be done as soon as possible. Many batteries are completely ruined by continued use after they need washing.

The temperature of a battery must not be allowed to exceed 100 degrees Fahrenheit. If no thermometer is available, the hand forms a fairly accurate test. Never let the battery feel very warm to your hand. If the battery warms up quickly, examine for short circuit, especially if the voltage drops quickly in running and it is difficult to obtain full mileage.

It is a very good plan to discharge the battery entirely at least once a month. This can easily be done by continuing the discharge through a rheostat after coming in from a run. By going over the cells with a low reading voltmeter at this time, a fairly good idea as to their condition may be obtained. A considerable difference in the voltage of the various cells is an indication that they need attention. Always recharge a battery as soon as possible after a complete discharge.

All dirt and acids should be kept from the terminals, as well as from the outside of the cells, including straps and the battery trays.

If any low cells are found, look for the cause. There may be sulphated plates, a dry cell due to a leaking jar, or cells may need cleaning.

The battery compartment must be kept dry. If a bottom is put in to keep the acid from dripping on the gear, care should be taken to have it arranged so that the acid runs off immediately. If the battery trays are allowed to stand in the acid, it rots them and the charge flows away through the wet wood.

OPERATION OF STEAM-DRIVEN AUTOMOBILES

In the steam car there is usually a high-pressure steam boiler to develop the power, delivering steam to an engine of two or more cylinders. The steam boiler is usually of the *flash-generator* type—namely a water-tube boiler in which the whole boiler consists of one or more long coiled tubes with thick walls and a small bore,

through which water is constantly forced by a pump. In a generator of this sort, water enters relatively cold at one end of the tube, and is delivered in the form of superheated steam under very high pressure at the other end.

A generator of this type has but a small reserve capacity, because of the small amount of water it can contain. It is therefore necessary to provide means for securing an abundant supply of steam when a sudden increase of power is demanded. This is usually accomplished by having the liquid fuel increased in unison with the operation of the circulating water pump, so that when more water is being pumped more fuel is being fed at the same time.

In the steam-engine-driven automobile, there is no need for any variable speed-gear, and the troublesome electric ignition is done away with. The engine itself has a wide range of power or flexibility, and this can be controlled in the simplest manner by merely admitting more or less steam to the cylinders. In addition to its flexibility, the steam car has the advantage of being practically noiseless in running and of being free from vibration, which latter is a feature of all internal-combustion engines. Its mechanism is also of the simplest type; hence it can be built lighter throughout, for the same power, than can a gasoline-driven car. Its limitations are such, however, that in some respects it cannot compete with the gasoline car. For instance, it cannot travel the same distance as a gasoline-driven car on the same amount of fuel, since the gasoline engine is far more efficient than the steam plant using gasoline as boiler fuel.

More attention is required to start and maintain the steam vehicle while running, than is demanded by the gasoline car.

The high-pressure boiler may be easily damaged through want of careful attention.

The main parts in a steam car are: Engine, boiler, and heater, pumps, transmission gear, water and gasoline supply-tanks, and controlling gear.

Steam cars usually do not have fly-wheels. With two double-acting cylinders, four impulses are obtained for every revolution of the crank-shaft, thus securing much more uniform turning effort than in a gasoline vehicle.

One of the most important features of mechanism in the steam

car is the force-pumps worked by the engine for the purpose of feeding the water supply into the boiler under pressure to replace that evaporated.

In most steam vehicles, speed regulation is accomplished altogether by the throttle-valve, by simply altering the quantity of steam passing to the engine.

The drive is either by chain from the engine-shaft to a power-

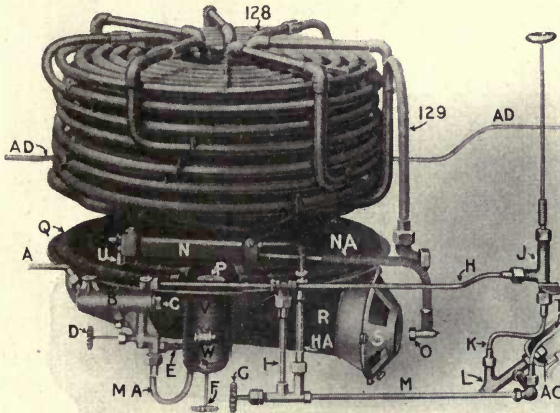

Fig. 145. Generator, Burner, and Fuel Connections of White Steam Car.

A—Supply-Pipe from Fuel Tank; B—Fuel Strainer Casting; C—Fuel Strainer Plug; D—Main Sub-Burner Valve; E—Sub-Burner Flush Valve; F—Sub-Burner Adjusting Valve; G—Warming-Up Valve; H—Pipe to Main Burner Valve; I—Pipe to Warming-Up Valve; J—Main Burner Valve; K—Pipe to Flow Motor; L—Flow-Motor Fuel Valve; M—Pipe from Flow-Motor Fuel Valve to Vaporizer; N—Vaporizer; O—Vaporizer Nozzle; P—Sub-Burner Cap; Q—Burner; R—Burner Induction Tube; S—Induction-Tube Shutter; T—Pipe to Vaporizer Gauge; U—Vaporizer Support Post; V—Sub-Burner Casing; W—Sub-Burner Casing Door; AC—Flow-Motor Stuffing-Box; AD—Pipe from Power Air-Pump; NA—Vaporizer Discharge Pipe; MA—Sub-Burner Supply Pipe; HA—Pipe Connecting Valve G with Vaporizer N; 119—Thermostat Cap; 129—Discharge to Engine.

ful sprocket on the rear axle, or direct drive as in the gasoline-driven automobile.

Care of Steam Cars. Water and gasoline tanks must be kept full. A supply of air must be pumped into the pressure reservoir for the gasoline-burner feed. The torch or sub-burner for starting the vaporizing process must be lighted, and shortly afterwards (in 3 to 5 minutes) the gasoline supply may be turned on in the main burner.

In a few minutes the steam pressure will have risen to a working point. Then the car is ready to run. The gauge needs to be watched

closely, as steam pressure rises very quickly, and too much fire at the burner will cause excessive steam pressure and open the safety blow-off valve.

To start, it is only necessary to push the throttle-lever forward slightly at first; and in order to stop, to shut off the steam supply and apply the brake.

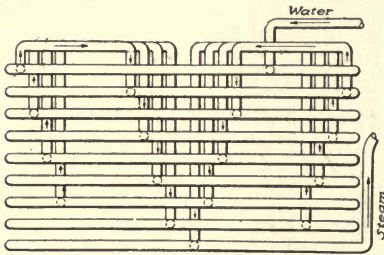

Fig. 146. Diagram Showing Circulation through Generator of White Steam Car.
The White Company, Cleveland, Ohio.

Since, in steam generators, scorching of boiler tubes results in serious damage, and even danger of explosion, the devices controlling water-supply to the boiler are features of construction requiring especial attention. In the White car, the water-supply is automatically regulated, obviating all need for the ordinary water-gauge, and removing all danger except from the grossest carelessness.

Injectors are but little used for feeding automobile boilers, because they would have to be made so small that they would be constantly clogged with dirt. Furthermore, an injector would fill

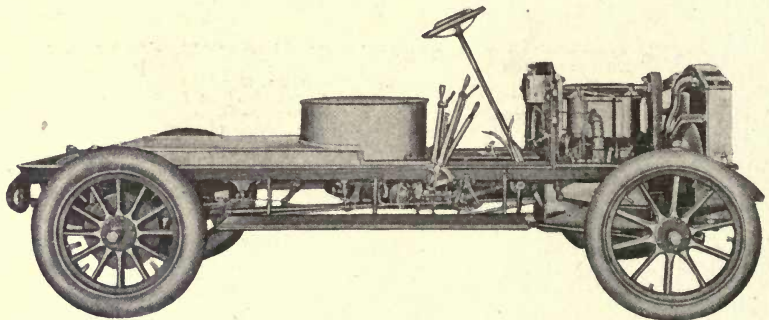

Fig. 147. Chassis of White Steamer, Showing Power Plant.
The White Company, Cleveland, Ohio.

the boiler too rapidly. Most usually plunger pumps are used, driven from the crosshead of the engine. Consequently, as long as the engine is in motion, water is being pumped into the boiler. When the water level is too high, the by-pass valve is opened, and the water is pumped over and back again to the tank. Automatic control of the by-pass is very desirable.

Pump troubles are usually due to loosened packings or clogged check-valves.

In inserting new packings, care must be taken not to pack the plunger too tight and cause breakage.

It is claimed as an advantage of the flash type of boilers, that,

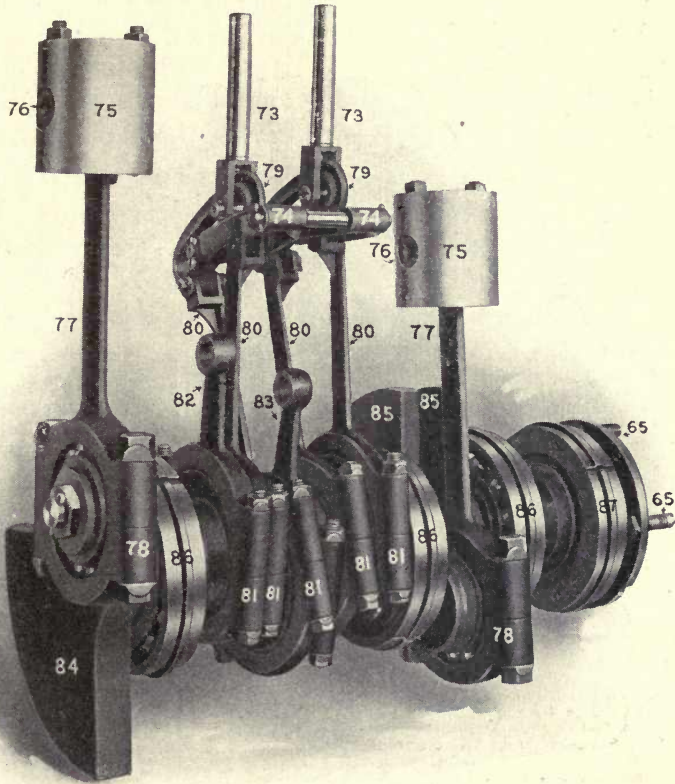

Fig. 147A. Crank-Shaft, Crank Eccentrics, and Link Motion in White Steam Car.

The White Company, Cleveland, Ohio.

65—Bolts Holding Universal Joint to Crank-Shaft; 73—Valve-Stem Bearings; 74—Link-Yoke; 75—Crosshead; 76—Crosshead Pins; 77—Connecting Rod; 78—Connecting-Rod Cap; 79—Valve Links; 80—Eccentric Rods; 81—Eccentric Rod Cap; 82—Air and Condenser Pump Eccentric Rod; 83—Water Pump Eccentric Rod; 84—Counterbalance Low Pressure; 85—Counterbalance High Pressure; 86—Main Bearing; 87—Main Thrust Bearing.

owing to the rapidity of steam generation, no incrustation is formed inside the tubes.

Fig. 145 shows the generator of the White steam car; and Fig. 146, the circulation system. Fig. 147 shows the chassis of this car. This car uses the Stephenson link valve-motion actuated by a set

of four eccentrics, instead of the cam-shaft valve-regulating system used in some other makes of steam cars. This is shown in Fig. 147A.

Water Regulation in Steam Cars. In the White steam car, when the engine is in operation, it operates the feed-water pumps. The *water-regulator* either by-passes all the water thrown by the

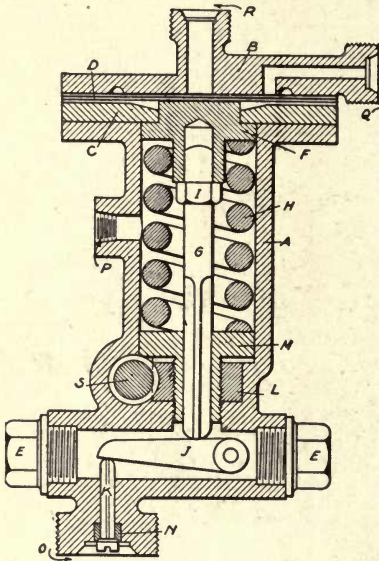

Fig. 147B. Water-Regulator of White Steam Car.

A—Main Casting; B—Water-Regulator Cover; C—Water-Regulator Washer; D—Four Diaphragms; E—Plug; F—Diaphragm Shifting Pad; G—Plunger; H—Spring; I—Lock Nut for Plunger Adjustment; J—Lever; K—Valve; L—Spring Adjusting Nut; M—Spring Adjusting Pad; N—Valve Seat; O—Connection to Pump Discharge; P—By-Pass; Q—Connection to Oiler and Steam Gauge; R—Steam Pressure Connection; S—Spring Adjusting Worm.

pumps, which is the case when the pressure is above 550 lbs., or it allows all the water to flow toward the generator when the pressure is less than 550 lbs. The water supply is either all on or entirely shut off, the required variation being automatically brought about by the action of the water-regulator shown in Fig. 147 B.

This water-regulator is a simple diaphragm valve actuated by the steam pressure in the generator. This valve is situated in the water-line, and acts either to permit all the water thrown by the two water pumps to be returned to the tank, or to permit none of it to be returned, the valve being open or closed, depending on the steam pressure. The steam pressure of the steam entering at the passage in the

upper center of the regulator, presses down against the four diaphragms, causing them to press down in turn on the diaphragm shifting pad located immediately under them, this action compressing the spring shown in section. The central spindle at the same time being impelled downward by the diaphragm shifting pad, moves the pawl-like lever shown at the bottom of the cut, this action causing the valve at the lower left hand of the cut to lift downward from its seat. The unseating of this valve permits water from the pumps to enter at the valve-seat just mentioned, this water being

forced up through the regulator, leaving it at the opening shown in the left center of the cut. When the steam pressure goes below the tension for which the spring in the regulator is adjusted (usually 550 lbs.), the diaphragms will return to their normal position, the water pressure closing the valve at the bottom of the cut.

Fuel Regulation in Steam Cars. Fuel is regulated in the White steam car by means of a device called a *flow motor*. This flow motor is a piece of mechanism in which the rate of flow of water through it is made to regulate the rate of flow of fuel to the vaporizing burner.

Fig. 147 C is a section of the White flow motor. Its action is as follows: Water enters the cylinder at 123 through a connection at the back not shown in the cut. It flows past the piston through a groove 195, and out through the branch pipe 124 to the steam generator. As the steam pressure drops and

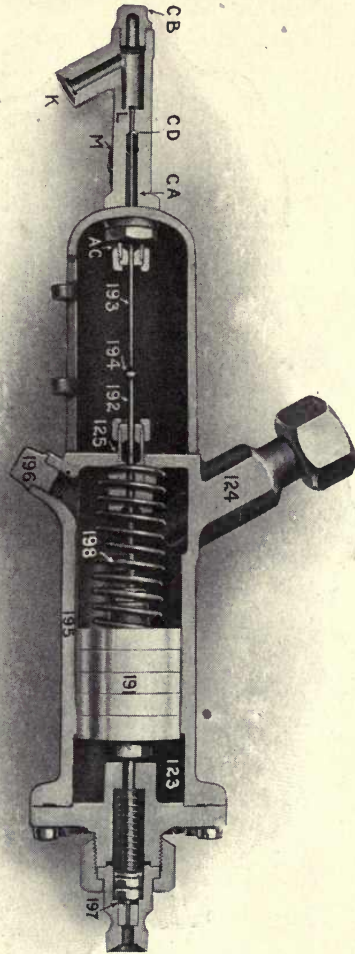

Fig. 147C. Flow Motor of White Steam Car.
 CB—Plug; K—Fuel Pipe to Flow Motor; L—Flow-Motor Fuel Valve; CA to CD—Graduation Valve Stem; M—Pipe to Vaporizer; AC—Stuffing-Box; 193—Valve Stem; 194—Valve-Stem Lock Nut; 192—Piston-Rod; 125—Stuffing-Box; 124—Outlet; 196—Plug for Draining; 198—Piston Spring; 191—Piston; 195—Groove; 123—Inlet; 197—By-Pass Valve.

operates the water-regulator described above so as to permit a greater flow of water, the increasing flow of water forces the piston down the cylinder, compressing spring 198 to a point where the

valve 197 at the bottom of the cut is drawn away from its seat, thus allowing part of the water to escape through the passage thus opened.

Attached to piston 191 is a small piston-rod passing upward through a stuffing-box 125 and through another stuffing-box *AC*, terminating in a fuel valve *L* in the upper part of the cut.

In the position shown in the cut, there is no water in the flow motor, and piston 191 is at the top of its stroke. Valve *L* is closed, and no fuel is passing from *K* through *L* and out at *M*. When the piston is compressed, however, the valve *L* is proportionally opened; thus permitting an increased flow of fuel to the vaporizing burner.

These valves, being of very small dimensions and very carefully proportioned, must be repaired or reground with the greatest caution, so as not to change the proportion between water and gasoline.

General Water System of a Steam Car. Fig. 147 D shows diagrammatically the various devices in the water system of a steam car, and how they are connected.

SELECTING A MOTOR-CAR

From Whom to Seek Advice. Probably the most disinterested as well as the most competent advice in regard to a car, would be such as is obtained from a mechanical engineer. While it is courteous to give heed to the experience of friends who own and recommend some particular make of machine, it must be borne in mind that their judgment is likely to be influenced by their own somewhat one-sided experience.

The automobile is a wholly technical aggregation of mechanisms, sold usually to a non-technical man. This condition is the reason for the common demand that the vehicle the purchaser wants shall possess all the fads and fancies of the year's fashion, whether the points in fashion have any real merit or not.

Character and Standing of Manufacturers. In purchasing a vehicle, it is well to study the character of the manufacturers, and is desirable to visit their manufacturing shop. It must be borne in mind that it is quite likely that the purchaser will have to have some repair work done on his car. Is the company you are considering

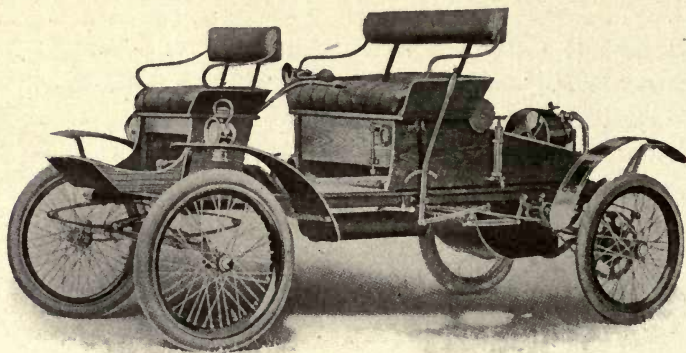

Fig. 148. Orient Buckboard.
Waltham Manufacturing Company, Waltham, Mass.

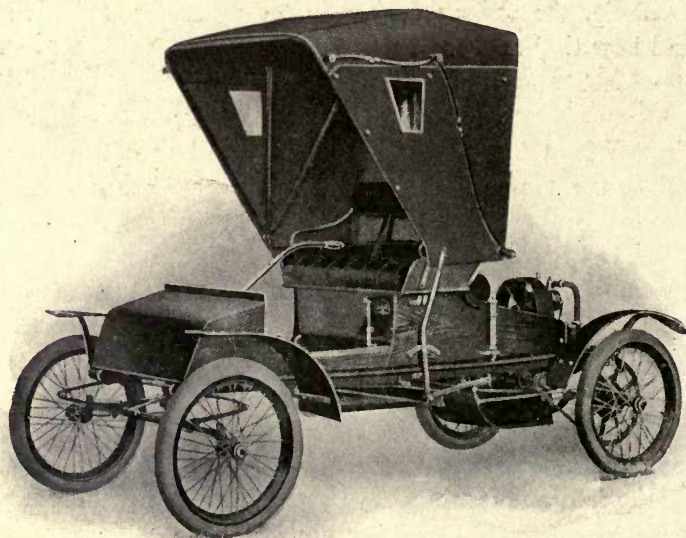

Fig. 149. Orient Buckboard, with Detachable Top.
Waltham Manufacturing Company, Waltham, Mass.

well enough organized so that they will give your repair order prompt attention? Is the company reliable enough to manufacture standard and interchangeable parts throughout a whole season, or is it a company whose individual cars vary with the whim of the shop proprietors and the carelessness and inaccuracy of the shop workmen? Is it a car whose cones, shafts, rods, bolts, and details in general are of all manner of varieties and sizes due to the enthusiasm of non-technical shop owners who are so anxious to keep up to date that they keep changing standards constantly? Are the managing heads

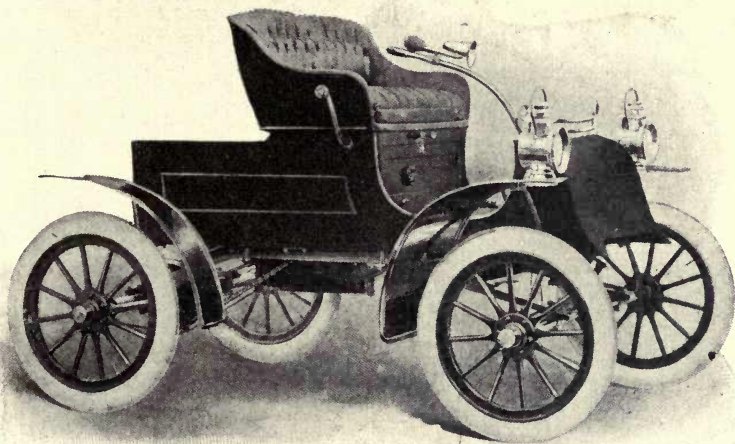

Fig. 150. Runabout.
Northern Automobile Company, Detroit, Mich.

of the company technical men, engineers capable of designing and manufacturing a high-grade engineering product?

Owing to the great demand for motor-cars, there has been a rush into the business, of manufacturers who are in no way qualified to build a high-grade mechanical product or to take care of the purchaser's repair troubles.

Men personally may be admirably qualified to build wheelbarrows, infant perambulators, farmers' buggies, and simple agricultural machinery; but these same men are not necessarily by any means qualified to build motor-cars. The qualifications required for the conduct of high-class automobile manufacturing enterprises are of a very special class. The following instance in connection

with non-technical ownership of an automobile shop, will serve as an example showing the dangers to which the purchaser exposes himself by buying from such a shop:

A motor-car company recently hired a first-class designer for a short time to work up engine designs, and then let him go—quite a usual procedure. As the fashion changed, larger cylinders were demanded. So the company had their drafting force, now without

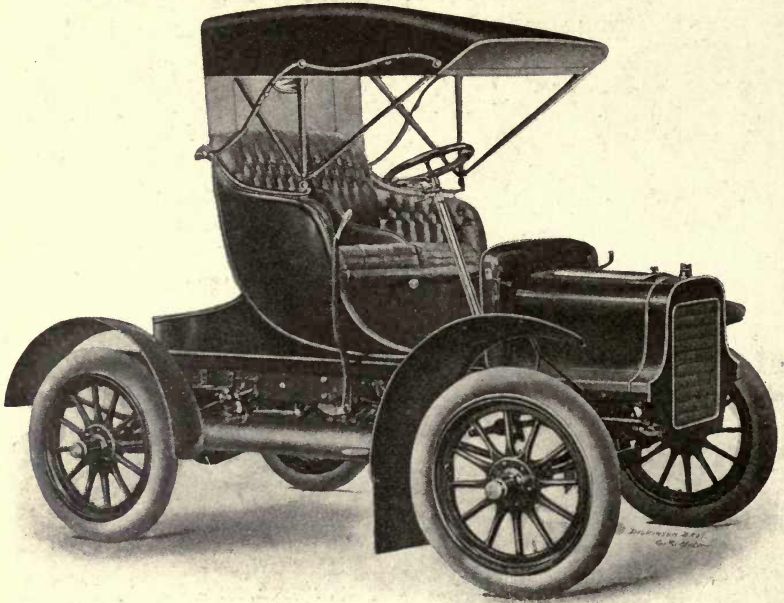

Fig. 151. Runabout, with Detachable Top.
Cadillac Motor Car Company, Detroit, Mich.

any competent designing head, put in the larger cylinders without making the proper alterations in design of bearings, shafts, and other parts. The result was that the following season's output of engines simply went to pieces.

Price. What price ought I to pay for my car? Can I get a good car for the price limit I have set? To a large extent these questions will confine themselves to certain limits after the question has been decided into which class your car will come by reason of the purposes for which it will be used the majority of the time.

There will unquestionably be a great market for fairly light cars

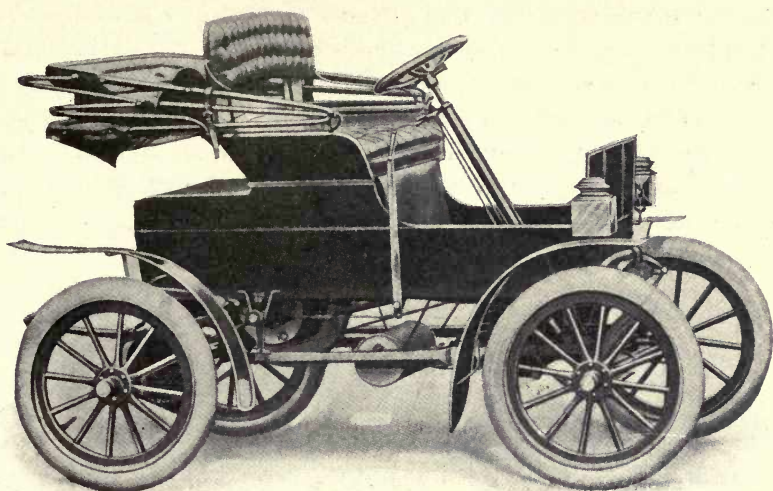

Fig. 152. Jewel Runabout.
Forest City Motor Car Company, Massillon, Ohio.

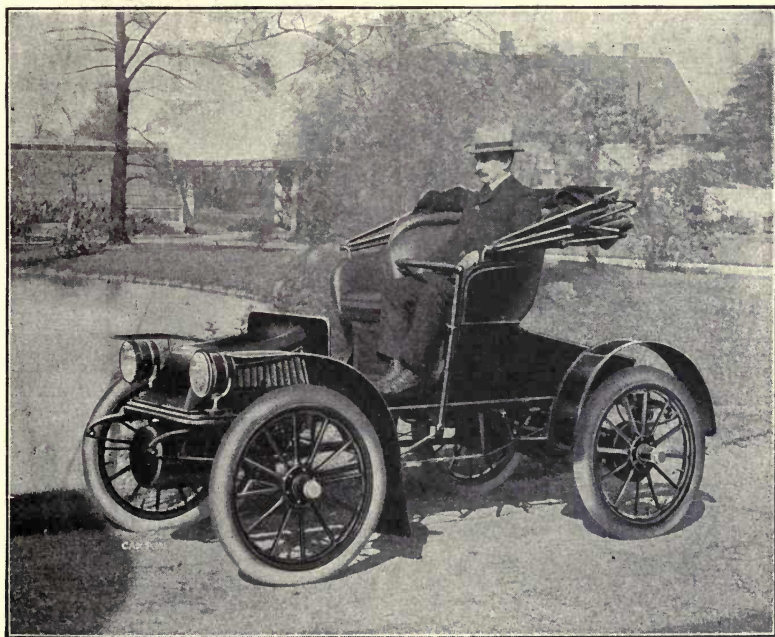

Fig. 153. Suburban Runabout.
Baker Motor Vehicle Company, Cleveland, Ohio.—Mr. W. C. Baker,
Designer of First Baker Electric, in Car.

to be run at moderate speeds and to be sold at prices between \$500 and \$1,500. A person needs to be particularly careful in selecting a car which is sold within this range of prices, especially if the manufacturing company is a new one.

In competition with such cars, it is worth while to consider a second-hand car of well-known high-grade make as a wholly qualified

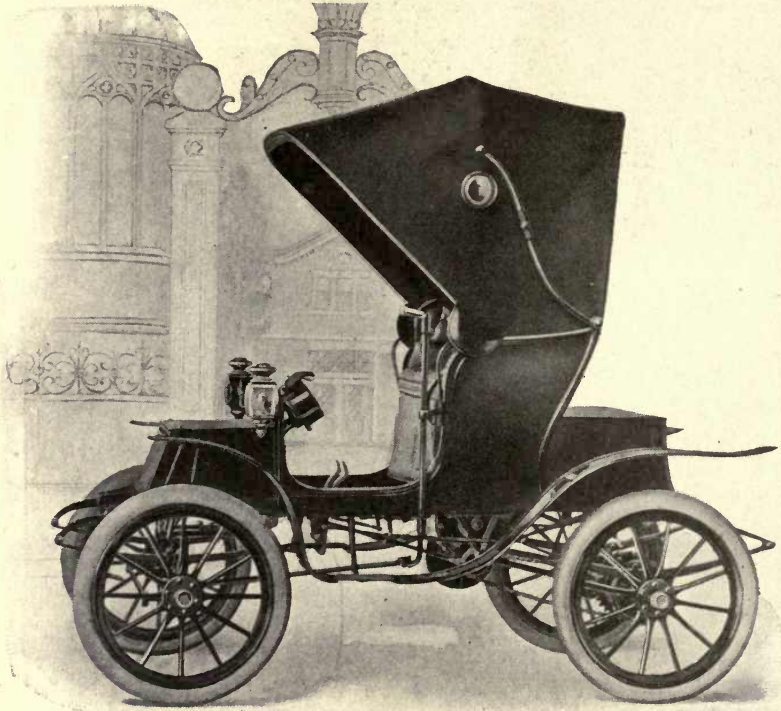

Fig. 154. Stanhope.
Sometimes equipped with detachable rumble seat.
Studebaker Bros. Mfg. Co., South Bend, Ind.

rival of the cheaper new car. In inspecting such a car, it is advisable to employ the services of an expert, or of an experienced driver or other thoroughly competent person who is as able to give advice on the merits of an automobile as is a piano expert or veterinarian in his own special line. In considering a second-hand car as compared with a new car of cheaper make, it is advisable to look up second-hand cars of the same general type and the same horse-power as the new



Fig. 155. Baker Electric Stanhope.
Especially adapted for driving by women.
Baker Motor Vehicle Company, Cleveland, Ohio.

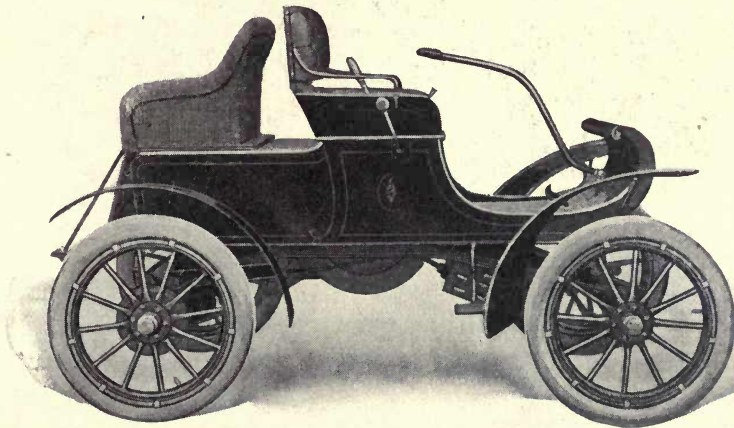

Fig. 156. Dos-à-Dos.
A type of seat arrangement (back to back) now no longer regularly manufactured.

car. The reason for this is that if a second-hand car of higher horse-power is purchased, it will cost more to maintain than the new car of smaller horse-power would. It will consume more gasoline, and the work on the tires and consequent wear will be much heavier. It must be borne in mind that the cost of operation and repairs is a higher percentage of first cost in high-power than in low-power cars. It is difficult to state in exact figures how much this cost of operation

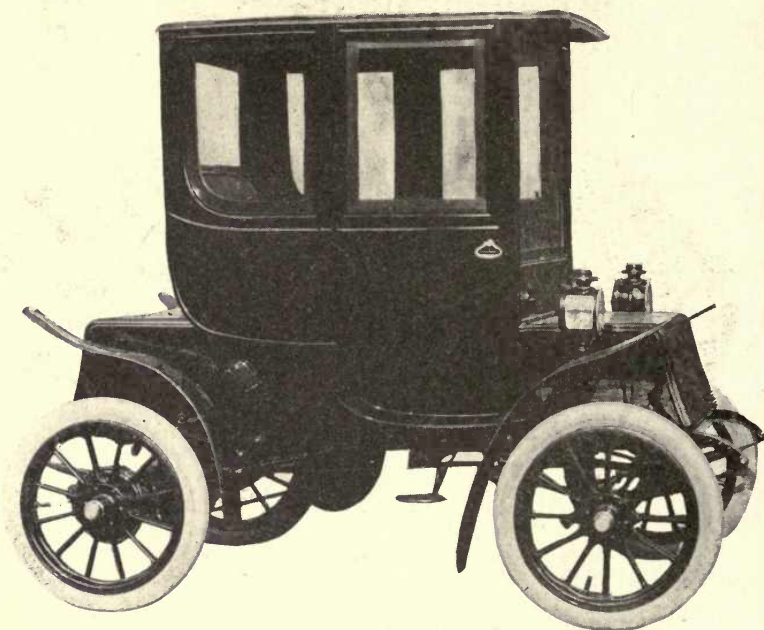

Fig. 157. Electric Brougham or Coupé, Inside-Driven.
Baker Motor Vehicle Company, Cleveland, Ohio.

and repairs will be; that depends on the amount of driving a man does. With a high-power fast car, the temptation is to drive hard, and thus run up the cost of fuel and tires.

In considering first cost and cost of maintenance of an automobile, it should be borne in mind that the motor-car is practically horses and carriage combined. Certainly its first cost, in order that it may be a good car, must be as high as that of an extra high-grade horse-propelled carriage, plus the cost of a well-built engine and necessary transmission apparatus. Its stable bill is little after it is at rest. The gasoline bill depends upon the mileage.

Tires. The largest item of expense is the tire bill. When we speak of tires, we naturally think only of pneumatic tires. Not sufficient attention has been given to the use of solid tires or of metal-shod pneumatic tires, each of which type has certain advantages in connection with commercial vehicles. Pneumatic tires are undoubtedly the most comfortable, but they are also by far the most costly.

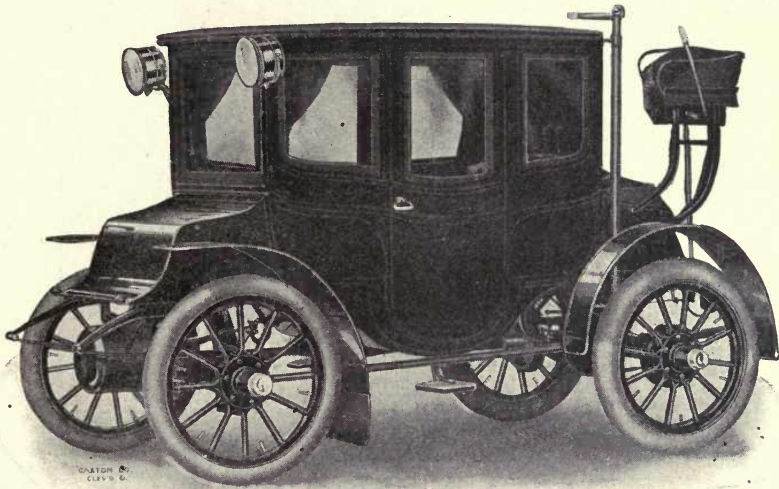

Fig. 158. Rear-Driven Brougham. A type now superseded by the front-driven Brougham. Baker Motor Vehicle Company, Cleveland, Ohio.

Second-Hand Cars. Frequently it is the custom for a novice to buy a second-hand car for his first season's experience.

The following rules should be observed in buying a second-hand car:

Pay no attention to paint, varnish, or upholstery.

Insist on a day's trial on hills and rough roads.

Dismantle engine, and examine condition of cylinders and bearings. If bearings are scored or cylinder manifests any crack when a candle or incandescent light is put inside the cylinder in the dark, the car should not be bought.

See that the axles are straight, and that all wheels run true and parallel.

Find number and type of engine as marked on it somewhere, and write to manufacturers of engine for date of manufacture. Many automobile manufacturers have the engines built at other shops, and the name of the manufacturer of the engine needs to be secured.

In the case of an electric car, have the batteries discharged through a recording voltmeter and ammeter; and see that the amperage of discharge is equal to the force required to run the car on a level road. See that the motor is in good condition and shows no evidence of overheated insulation.



Fig. 159. Baker Electric Surrey, with Cape Top.
Can be quickly converted into an inclosed vehicle in stormy weather.
Baker Motor Vehicle Company, Cleveland, Ohio.

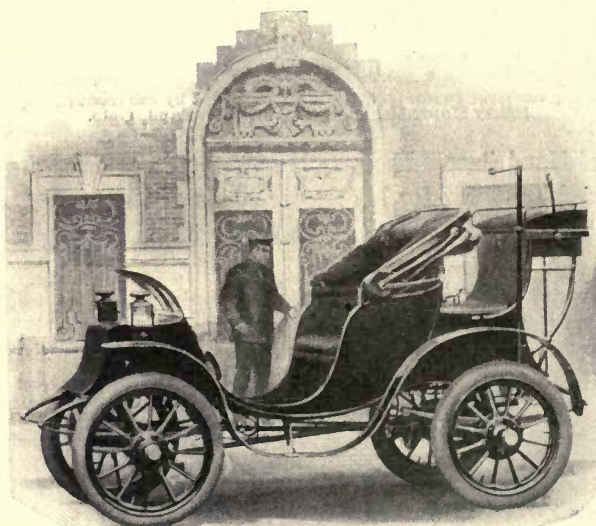

Fig. 160 Baker Electric Victoria.
Especially adapted as a private carriage for shopping or for park or avenue driving.
Baker Motor Vehicle Company, Cleveland, Ohio.

Demonstrations. In investigating the relative merits of different types of cars, one should not lay too much stress on a single demonstration. The conditions on the occasion of that demon-

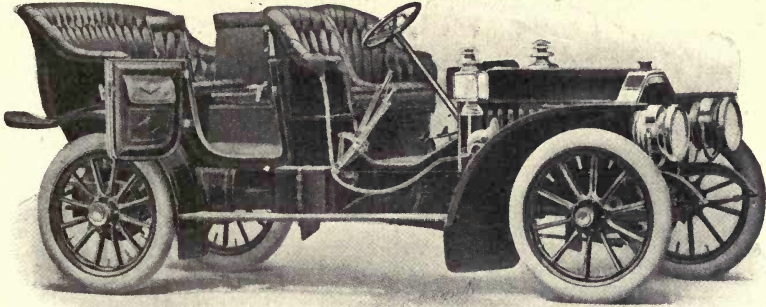

Fig. 161. Touring Car, Seven-Passenger, 30-Horse-Power.
Peerless Motor Car Company, Cleveland, Ohio.

stration may have been exceptionally good or exceptionally bad. The demonstration may have been tuned to the prospective buyer's fancies as indicated to an observant salesman who has carefully

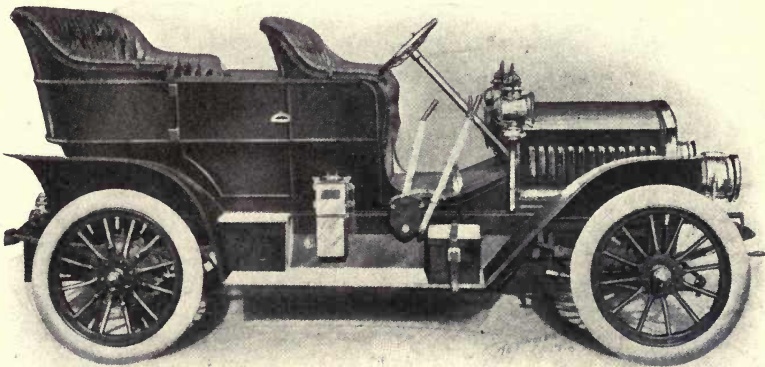

Fig. 162. Frayer-Miller Touring Car, 24-Horse-Power.
Oscar Lear Automobile Company, Springfield, Ohio.

noted them and has instructed the demonstrator accordingly.

Into whichever classification our car may come so far as regards the purpose for which it is to be used, it is certainly sure that it is always the wise course to demand of the car just a little less than its

limit of capacity, speed, or endurance. The cheaper the car, the more important is this caution.

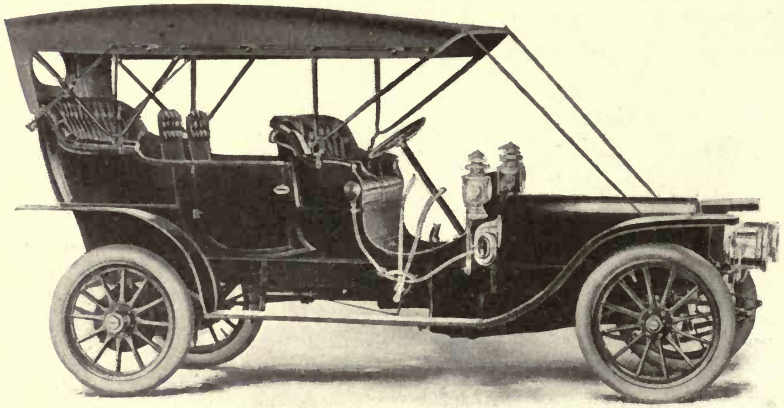

Fig. 163. Franklin Touring Car, with Detachable or Cape Top.
H. H. Franklin Manufacturing Company, Syracuse, N. Y.

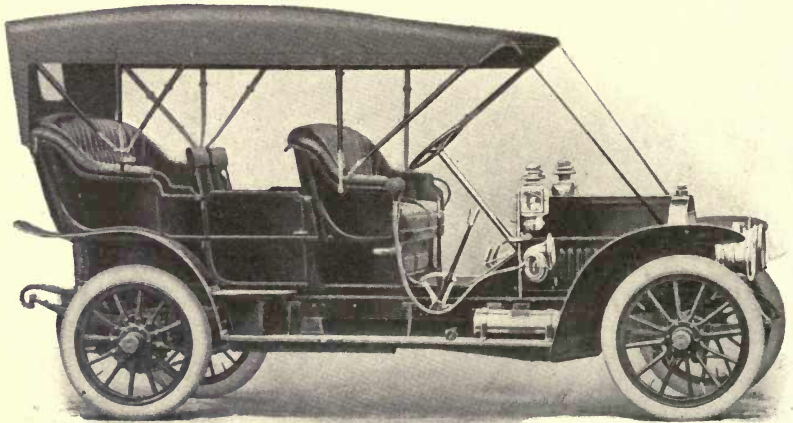

Fig. 164. Touring Car, with Detachable Top.
Four-Cylinder, 40-Horse-Power.
American Locomotive Automobile Company, New York, N. Y.

In watching a demonstration, one should note particularly whether there is difficulty, delay, or noise in changing gears; difficulty or delay in braking; overheating; or trouble in starting.

Relation between Horse-Power and Weight of Car. Formerly a car was considered as being powerful enough if it had one horse-power to 100 pounds. Popular demand at the present time is for a horse-power to every 50 or 75 pounds. The reason for this is that it eliminates the necessity of a change in gears, permitting running on the

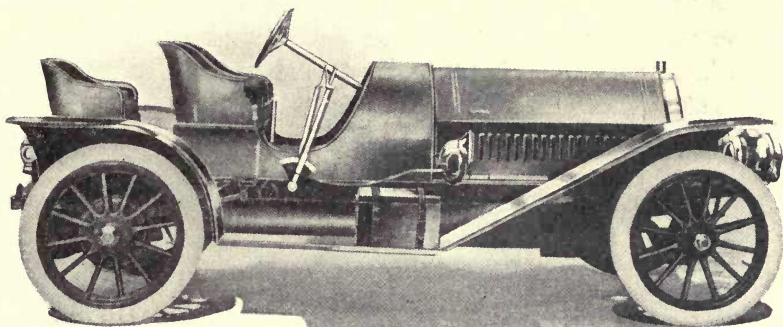

Fig. 165. Jewel Roadster.
Forest City Motor Car Company, Massillon, Ohio.

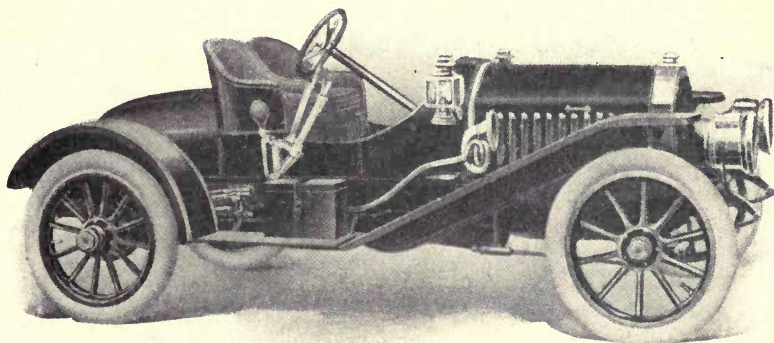

Fig. 166. Roadster, 30-Horse-Power.
Peerless Motor Car Company, Cleveland, Ohio.

high gear practically all the time, even when hill climbing. With abundant power in the engine, the disadvantage of running the engine at high speed is done away with a large part of the time. Continued running at high speed means the wearing-out of the different parts. The slower the engine is run without straining it, the longer it will last.

High speed and great weight always mean a great amount of wear and tear. Going at high speed is to most people far from a pleasing sensation, when kept up as a regular thing.

The power developed by gasoline motors or engines several years ago was not much more than one-half, for a given diameter of cylinder and stroke, of what it is to-day. A few years ago a good water-cooled motor averaged from 13 to 15 pounds weight of engine to the horse-power. This figure has been reduced to as low as 10 pounds of weight to the horse-power.

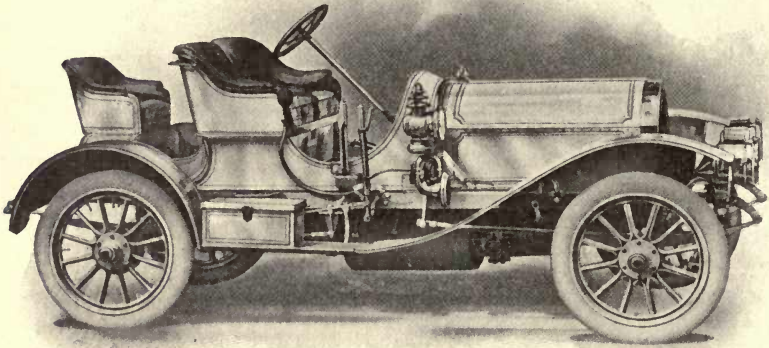

Fig. 167. Sportabout.
Knox Automobile Company, Springfield, Mass.

Easy Riding. A great aid to easy riding is to have the center of gravity of the car as near the ground as possible, with, however, plenty of clearance below the front and rear axles. Large wheels permit of this clearance and give easier riding, as they do not go into small ruts or bumps. A low center of gravity gives less bounding and less danger of turning the car over. With a low car, large wheels must be used.

Rear trucks should be located well back, as in this position easier riding is secured.

Long springs are conducive to easy riding. The American Berliet has a rear spring 43 inches long, and a front spring 36 inches long.

Springs built up of leaves of considerable width, and relatively thin—for example, not less than $1\frac{1}{4}$ inches wide and $\frac{1}{8}$ inch thick—have been found to wear better than those with narrower and thicker laminations.

The easy-riding qualities of a spring depend on its resilience and its ability to absorb shocks without undue recoil. As already stated, this action is facilitated by the use of a long spring. In this respect the three-quarter elliptic is better than the half- or full-elliptic, excepting where the half-elliptic is suspended to a cross-spring at

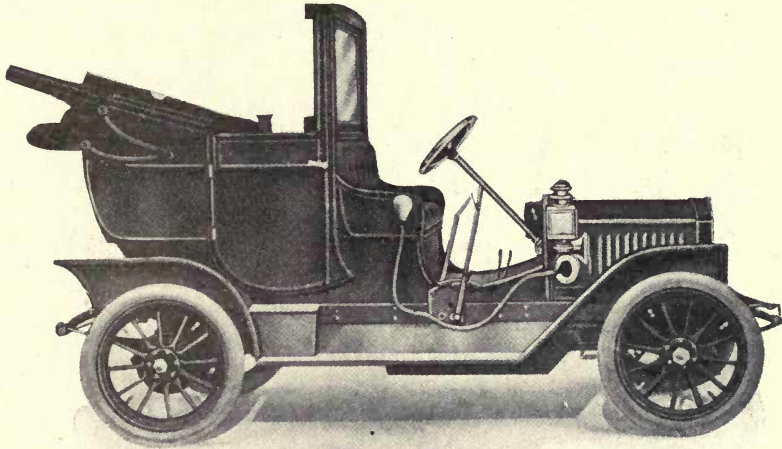

Fig. 168. Frayer-Miller Taxicab.
Partly a pleasure, partly a commercial vehicle. Extra seats for four passengers in rear. Equipped for public service and supplied with a taximeter.
Oscar Lear Automobile Company, Springfield, Ohio.

right angles to it. Various types of hinged or dashpot types of shock absorbers have also been used with success to lessen the recoil action of springs. It is claimed in behalf of the three-quarter elliptic, that it acts as a shock absorber. The three-quarter elliptic is simply a half-elliptic with a quarter-elliptic supporting one end of it; or it might also be defined as a full-elliptic with one upper quarter cut away.

Ease of Access. The parts liable to require adjustment at any time should be easy of access, without the need of dismantling or partially dismantling the car.

Among the parts which are likely to require adjustment, and

which should always be easy of access, are: Engine inlet and exhaust valves; commutators; pumps (oil and water); clutches; clutch springs; gears; brakes; throttle and spark rods.

Of late years, considerable attention has been paid by most makers to securing accessibility of engine parts; but the same is not true of the rest of the mechanism.

In the case of the engine as a whole, there is no question but that it is easier to lift off a hood than to lift out the floor. At the same time, in the case of clutch and clutch springs, it is easier to lift out the

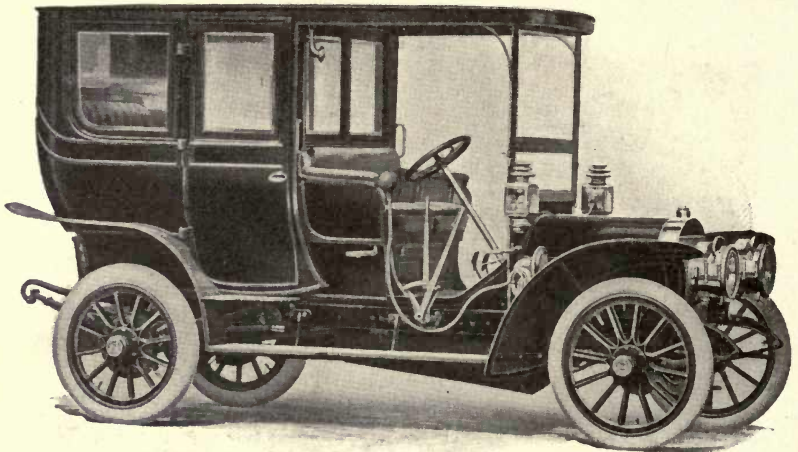

Fig. 169. Limousine, Four-Cylinder, 22-Horse-Power, Shaft Drive.
American Locomotive Automobile Company, New York, N. Y.

floor than to have to take off the whole body. Almost all vehicles are built so that the floor can be taken out; but in many the design is such that after that is done the parts are not sufficiently accessible.

INSTRUCTION IN DRIVING

It is not at all difficult to learn the function and method of operation of the parts which have to be handled in driving a car. These parts include the steering wheel, the throttle and ignition levers, and the brake and change-gear levers and pedals.

To become an expert driver, however, is a different matter. This requires alertness of mind; a refinement of the senses of sight, touch, hearing, and smelling; and an ability to anticipate conditions

which are to be met. A person whose mind and senses are sluggish will never make a good driver. Experience in bicycling or in sailing is of value, since it has brought into play the same mind and sense training that are required in automobiling. The first attempt at automobiling should be made in company with an experienced driver, who sits next to the novice, controlling everything at first except the steering wheel. The car should be run at its slowest speed. After the steering has been fairly mastered, instruction is given by the driver in one after the other of the parts; but plenty of time should be taken, and the points taken up only one at a time.

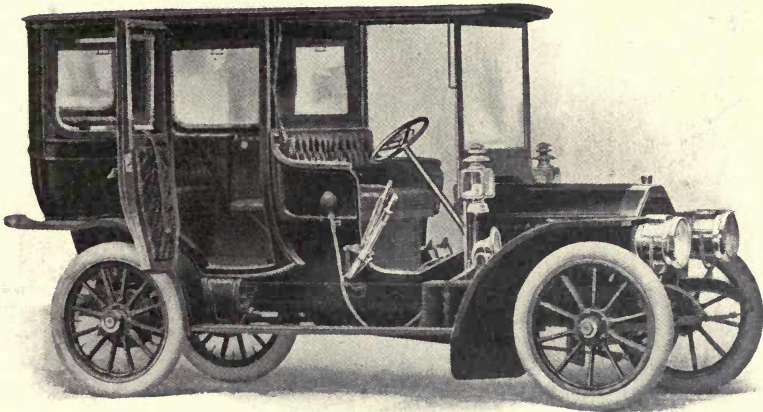

Fig. 170 Limousine, 30-Horse-Power.
Peerless Motor Car Company, Cleveland, Ohio.

When learning, one should practice making short turns, starting, stopping, changing speeds, driving backwards, and turning the car about.

From the very start, avoid using the brakes, so as not to get into the habit.

Gear Reduction. The usual range of reduction of drive-shaft speed to rear-axle is from 4 to 1 to $2\frac{1}{2}$ to 1, the most prevalent being about 3 to 1. Some of the lighter cars are equipped with a greater reduction, the Cadillac having used a 4.9 to 1 ratio for a considerable time. With a greater gear reduction, the fault of most drivers, of running too fast, is held in check; and there is less wear and tear on the car as a whole, although the engine will always be running at a

higher speed than with a lower gear reduction. The advantages of a low reduction consist in the fact that the engine and all intermediate moving parts between the engine and rear axle run at lower speed and are subject to less wear with a low reduction. For instance, with a ratio of 3 to 1, the engine shaft would be running three times as fast as the rear axle, and with the ratio 4.9 to 1, the engine would be running 4.9 times as fast. On the other hand, it must be borne in mind that with the latter arrangement one could run

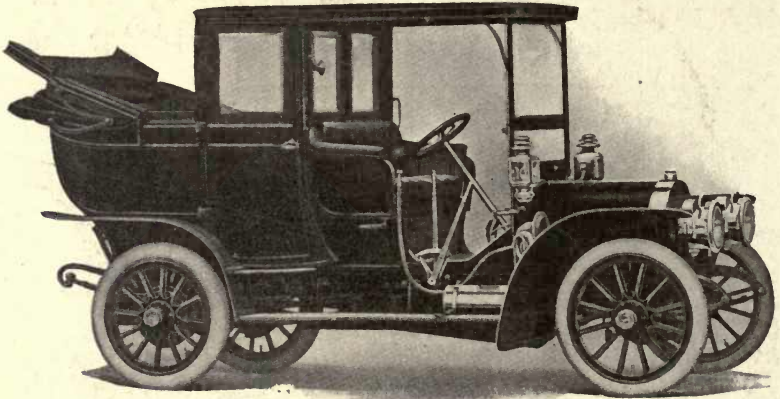

Fig. 171. Landaulet, Four-Cylinder, 22-Horse-Power, Shaft Drive.
American Locomotive Automobile Company, New York, N. Y.

his car as fast and would not wear out his tires as fast as with a low ratio.

Range of Speeds Obtainable through Gears. Most cars with gear reduction provide three changes of speed. If the engine power is liberal for the weight of the car, it is likely that the driver will seldom make use of more than two speeds; and a number of cars built at moderate price for family use are appreciating this fact by providing but two speeds.

The same is true of a heavy car provided with a liberal surplus of engine power. For instance, for motors having six or eight cylinders, two speeds would be amply sufficient.

Levers and Pedals. The positions of levers for varying speeds should be so distinct that there will be no likelihood of making mistakes through absent-mindedness, carelessness, or "getting rattled."

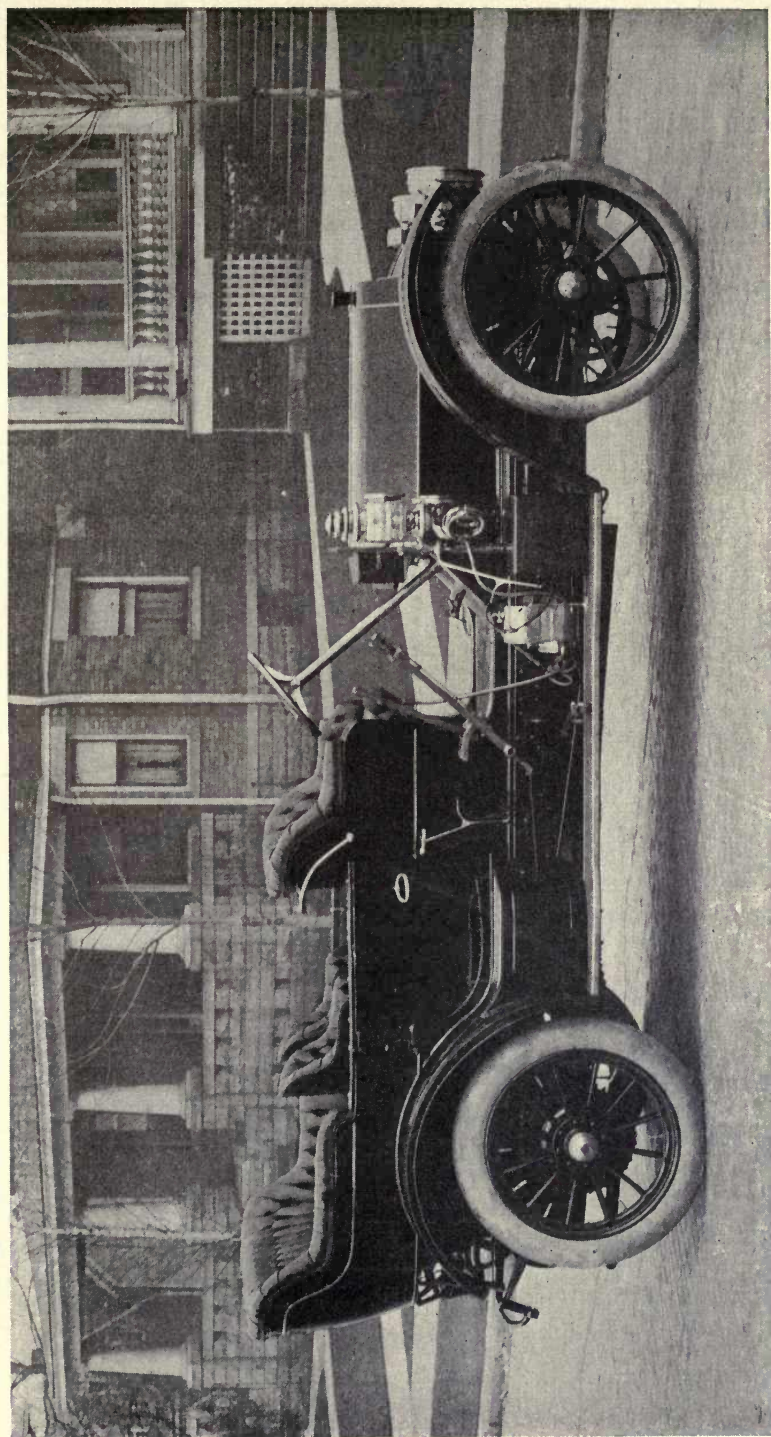

Fig. 172. Stearns Seven-Passenger "Pullman" Touring Car, 1908 Model.
The F. B. Stearns Company, Cleveland, Ohio.

For instance, in an arrangement in which throwing the lever forward means full speed, throwing it backward means slow speed, and the foot-pedal is used for reversing and braking, there is less liability to error than in arrangements where one lever has to do nearly all of these tasks, especially where the lever position itself is not suggestive of the result.

Any car should be made so that as much of its operation as possible can be done by foot-pedals.

Power. The test of power is hill-climbing. Whatever the

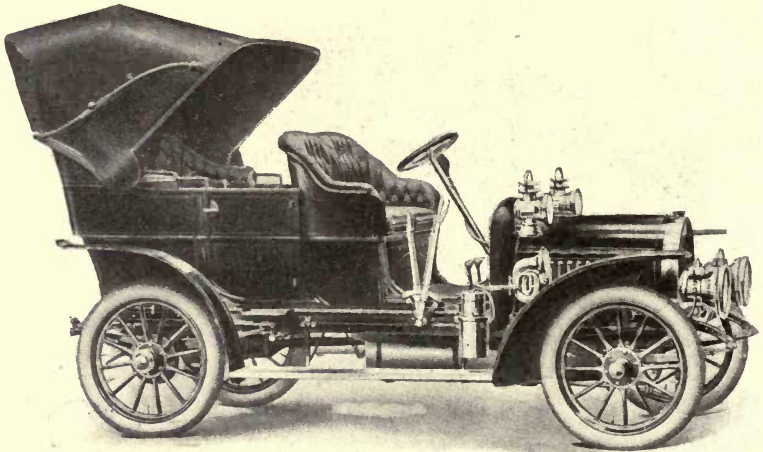

Fig. 173. Cabriolet.
Studebaker Bros. Mfg. Co., South Bend, Ind.

rated load of a car, it should take that load up a hill easily and without strain, and at a good speed. A car that can go thirty miles an hour down hill, and only four miles an hour up hill, would, if we had a hill a mile up and a mile down, take for the two miles 15 minutes up and two minutes down, or at the rate of $8\frac{1}{2}$ minutes per mile. A car going up the hill at ten miles an hour, and down it at twenty miles an hour, would take 6 minutes up and 3 minutes down, or 9 minutes altogether, making the average speed of $4\frac{1}{2}$ minutes per mile, just about twice the average speed of the light-power high-speed car; and this average would be maintained on a day's run over ordinary up and down, smooth and rough roads. With an under-powered car, there is always the temptation to scorch when

on the level or going down grade, wearing out tires and increasing the danger of accidents. With amply powered cars, this desire to scorch to make up time passes away, because the real running time is lessened.

Drivers. If one does not intend to drive his own car, he certainly needs a competent driver. It is as much of a mistake to put a man who has been a coachman in charge of a motor-car as to put him in charge of a power plant. A man qualified to take good care of animals may not be at all competent to operate intricate machinery.

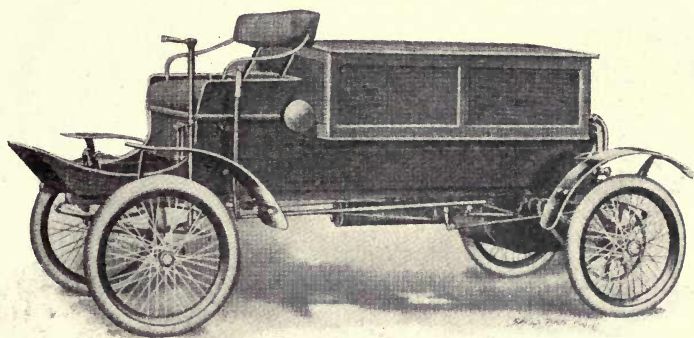

Fig. 174. Light Delivery Wagon.
Waltham Manufacturing Company, Waltham, Mass.

The chauffeur needs to be a combination of gentleman and engineer; and such a one can be secured only by paying at least the wages of a competent engineer.

Steering Gear. As the most serious and dangerous accidents are likely to occur as a result of a break in some part of the steering gear, it is highly important that all parts going to make up this feature of the vehicle be extraordinarily strong. The movement should be positive, with provisions for taking up wear. Back-lash in steering mechanisms is very undesirable.

Steel castings are the only class of castings that can be considered in connection with steering gear. Cast or malleable iron is unfit for use in this connection. Forgings should be of a high grade of metal, and forged in a manner that will guarantee that no overheating shall occur. A visit to the manufacturers' plant or to the plant of the concern from which one buys his parts for steering gear, is well worth while.

Breaking of levers or any rod or link or fastening in the steering mechanism, will almost always cause some kind of accident.

Clothing. When driving at twenty miles an hour, the air will actually pass through ordinary overcoats and cloth garments; hence it is necessary that clothing be air-proof, and so contrived that air will not get under the garments.

Leather clothing does not permit of the evaporation of the

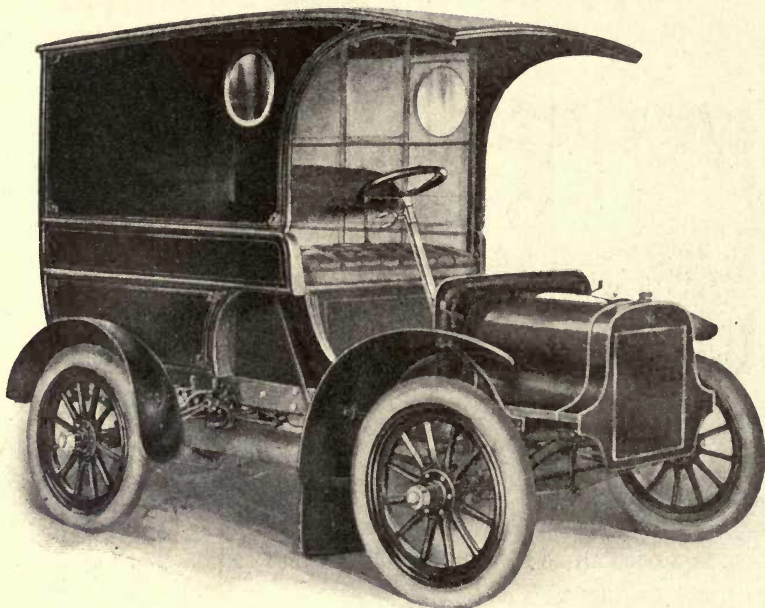

Fig. 175. Delivery Car.
Cadillac Motor Car Company, Detroit, Mich.

natural moisture of the body; hence, when it is used, it should be provided with small holes so placed as to provide for the evaporation of this moisture, and at the same time to prevent admission of wind and rain.

The coat should by all means be so made as to fit closely at the wrists. Goggles are indispensable if no front glass is used on the car.

It is worth remembering that if you are in a rain and have no top, the seat cushion should be put inside your coat and not outside.

Top. If the purchaser intends to maintain but one automobile, the body should by all means be provided with either a permanent or an easily attachable top. It is beginning to be appreciated that an automobile is not merely a fair-weather vehicle, but a carriage for all seasons. A modernly equipped automobile provides protection against bad weather, and does away with the necessity for wearing strange apparel making one resemble a diver.

A person who is desirous of traveling in comfort will provide his car with a suitable cover as a protection against wind, rain, dust,

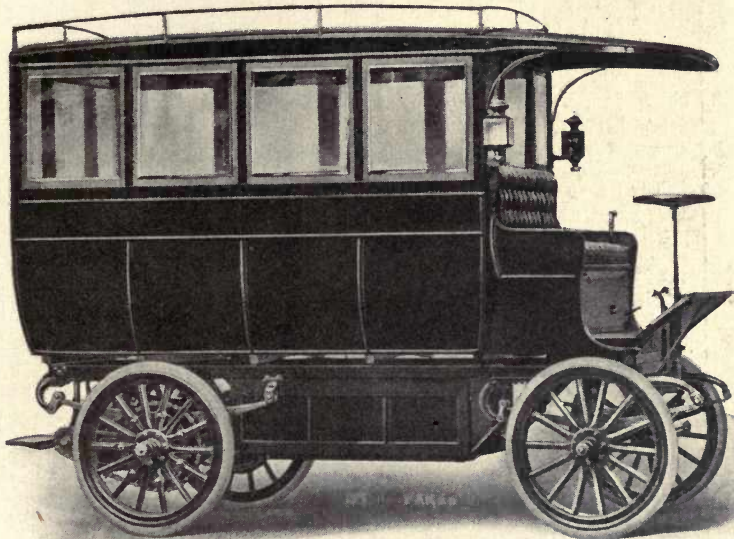
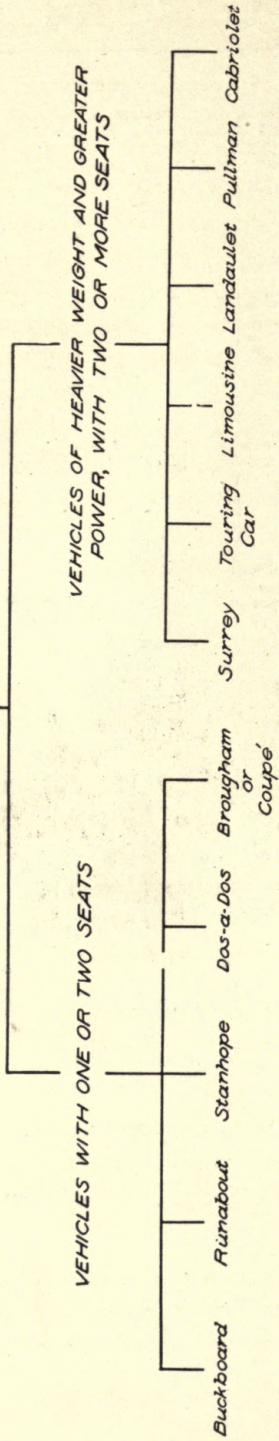

Fig. 176. Auto-Bus or Omnibus.
Studebaker Bros. Mfg. Co., South Bend, Ind.

and mud, without his having to wear any hideous garments. There are certain conditions, however, where a car must be driven stripped—for instance, in conducting mileage trials of cars in process of manufacture. Experienced road testers have all come to learn the need of a tight band about the neck and sleeves. Goggles, ugly as they are, are indispensable to anyone going faster than moderate speeds in a car not provided with glass front.

Accessories. The number of accessories is legion. Many of these are of doubtful utility, and are likely to become a source of annoyance after the wane of the first enthusiasm.

PASSENGER VEHICLES



COMMERCIAL VEHICLES

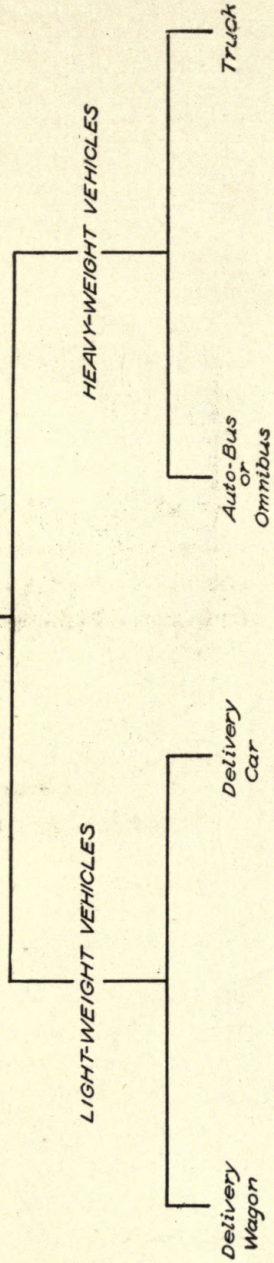

Fig. 177. Classification of Motor Vehicles.

Powerful *searchlights* are disagreeable; owing to the sharp contrast, everything not in their range is invisible.

Acetylene *lamps* are usually more troublesome than oil lamps if the gas is generated on the car. The use of compressed gas which is supplied in cylindrical tanks attached to the side of the car, has become almost universal.

Small *dynamos* for furnishing lights can be attached to the car as easily as a dynamo for sparking, and are likely to gain in popularity.

An article which perhaps is more of a tool than an accessory, and which should not be overlooked by any means, is the *jack*. This article should not be kept at home, but should be carried with the car.

CLASSIFICATION OF MOTOR-CARS

We have already classified cars on the basis of their power plants and methods of power transmission. They may also be classified according to the special uses to which they are put, and from this standpoint fall under two broad headings—(1) Passenger Vehicles; (2) Commercial Vehicles. These groups may be further classified as shown in the accompanying diagram, Fig. 177.

The various types of cars may be more fully described as follows:

Passenger Vehicles with One or Two Seats

1. *Buckboard*—Figs. 148, 149.
Has a skeleton frame with no body. Very light weight.
2. *Runabout*—Figs. 150, 151, 152, 153.
A vehicle with or without a top, having capacity for two passengers. Particularly adapted for business purposes or pleasure, because it is so compact, neat, and handy.
3. *Stanhope*—Figs. 154, 155.
A two-seated vehicle with a top. So named after Lord Stanhope. The top is usually open or of the Victoria style. This type of vehicle is of better finish and design than the runabout, and is in great favor with ladies and physicians.
4. *Dos-à-Dos*—Fig. 156.
Runabout style with two seats back to back. Bodies of this type are not now regularly on the market; they are made only on special order.
5. *Brougham* or *Coupé*—Figs. 157, 158.
A one- or two-seated car with the body entirely enclosed or with the

driver's seat left exposed. This vehicle is popular with physicians, as it affords such excellent protection against wind and storm.

Passenger Vehicles with Two or More Seats

1. *Surrey*—Fig. 159.

A car of very light weight, with two seats, one of which may be folded away when not in use. Sometimes made with a side entrance, in which case it resembles a touring car. The *Victoria* (Fig. 160) is with many a favorite type of private family carriage.

2. *Touring Car*—Figs. 161, 162, 163, 164.

So called because it is constructed to withstand long drives over country roads. Usually seen without a top. The top which may be used with this type of car is called a *canopy top*, and can be taken off and folded away when not in use. A folding glass front is also used; but, unless the car has a high power, it will set up a resistance to the wind. The *Roadster* or *Sportabout* (Figs. 165, 166, 167) is a

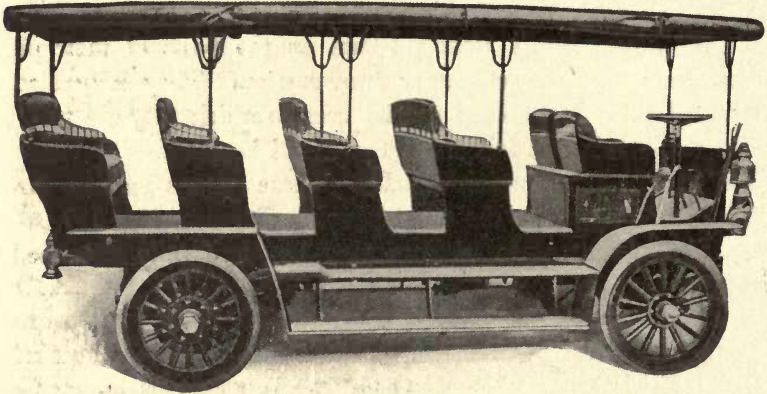

Fig. 178. Stage for Eighteen Passengers.
Oscar Lear Automobile Company, Springfield, Ohio.

type that may be said to be intermediate between the runabout and the touring car, combining the features of compactness, strength, durability, and speed. The *Taxicab* (Fig. 168) is partly a pleasure, partly a commercial vehicle, equipped for public service and supplied with a taximeter.

3. *Limousine*—Figs. 169, 170.

Similar to a canopy-topped touring car, except that this style of car has its sides more or less completely enclosed. A great objection to the limousine is its immense weight.

4. *Landaulet*—Fig. 171.

Similar to the limousine. Instead of its top and sides being of rigid construction, they may be folded down when not in use.

5. *Pullman*—Fig. 172.

This is a very large car, seating six persons. Often entirely enclosed except for driver's seat, and usually provided with tables, rotating chairs, and sometimes sleeping accommodations.

6. *Cabriolet*—Fig. 173.

Has a Royal Victoria top over rear seat. Otherwise, in style and shape, it resembles the touring car.

Commercial Light-Weight Vehicles

1. *Delivery Wagon*—Fig. 174.

Corresponds in weight and horse-power to the runabout, and is used as a parcel delivery or for laundry work.

2. *Delivery Car*—Fig. 175.

The weight and horse-power are similar to those of the touring car. Can be used for heavier work than the "wagon."

Commercial Heavy-Weight Vehicles

1. *Auto-Bus or Omnibus*
—Figs. 176, 178.

Used for commercial purposes, either for sight-seeing or to convey passengers to and from depots.

2. *Truck*—Figs. 179, 180.

Fig. 179. Packard Truck.
Packard Motor Car Company, Detroit, Mich.

This is in a class by itself because of its exceptionally great weight and power, and is geared for slow speed. The *Van* (Fig. 181) is an enclosed truck for heavy service.

Purposes for which the Automobile is Wanted. In selecting an automobile, the first question to consider is the purpose for which the vehicle is to be used the greater part of the time. The various purposes for which cars are used may be indicated as follows:

1. A business man's means of conveyance between his business office and his residence.
2. A conveyance used by ladies in making calls or in shopping.
3. A physician's vehicle.
4. A vehicle owned by a business establishment for purposes of transportation and entertainment of customers and guests.
5. A family vehicle for pleasure drives.
6. A vehicle for sport on land, corresponding to the power yacht in water.
7. A light delivery wagon.
8. A truck, a dray, or a van.
9. An omnibus.
10. A self-propelling railway car.

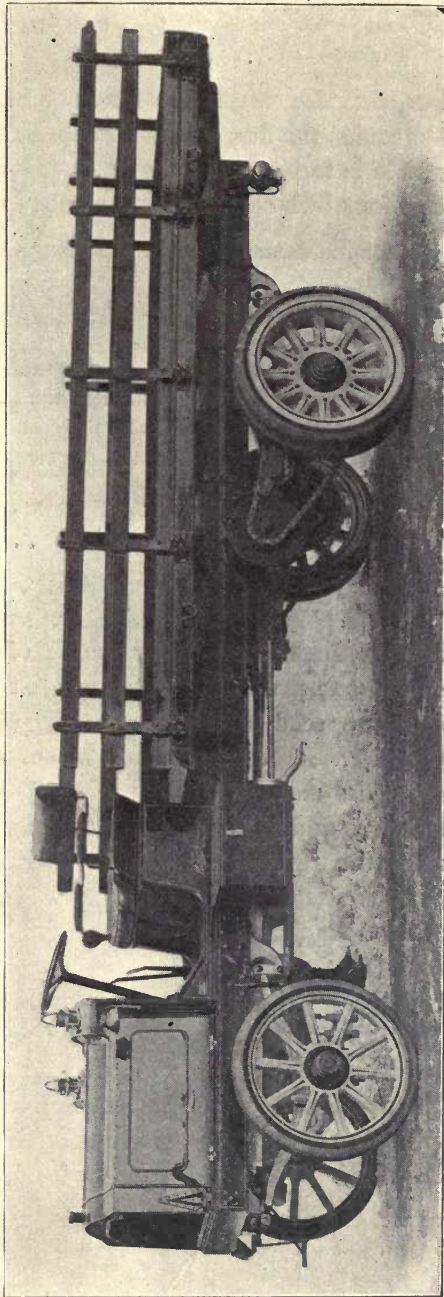
Having determined under which of the above headings our vehicle will come, we shall consider what type of vehicle is adapted to meet our special requirements.

CLASS 1. *A business man's means of conveyance between his business office and residence.*

In towns and smaller cities, and for a run of not to exceed five miles between residence and office, if roads are good, the electric vehicle is available for this purpose. In cities like Indianapolis, Ind., and Columbus, Ohio, a large number of electric vehicles are put to this use.

In larger cities, and where fine roads are not so abundant, however, the gasoline car is preferable on account of its greater speed and power. In the case of light cars for this purpose, the tendency is in the direction of two-cylinder runabouts. A decreasing number of single-cylinder makes is being marketed every year.

CLASS 2. *A conveyance for ladies.*

There is but little question that for this purpose the electric vehicle is the best. As between a motor-car and horses for this service, there is nothing but sentiment in favor of the horse, as one car

will take the place of several pairs of horses. The electric is pre-eminently a city and suburban car, and in this field it is permanent. It is by far the simplest to operate. More members of a family can use it than would be the case with any other form of motive power. It is silent and swift enough for safe driving. It requires less attention and care than any other type of car, and consequently its cost of maintenance is less. Its radius of operation is limited to some ten or twelve miles, however.



Fig. 180. Frayer-Miller Motor-Truck.
For delivery of furniture or other bulky and heavy goods.
Oscar Lear Automobile Company, Springfield, Ohio.

Among the advantages claimed for electrical vehicles are the following:

They are always ready—something which can hardly be said of any other type of automobile. They can be operated at less cost, day by day, than any other type of car. They can be used in all sorts of weather and at all seasons of the year, being the only satisfactory cars for winter use.

CLASS 3. *A physician's vehicle.*

A physician is likely to want to take a great number of relatively short trips in all sorts of weather. If his mileage does not exceed the limits of an electric vehicle, which at a conservative estimate may be put at 30 to 35 miles per day on

fair roads without steep hills, the electric car is by far the most convenient.

The noise of a gasoline car is likely to be objectionable, particularly in case the engine is left running while the car stands; and if the engine is shut off, the physician has to lose some time and do some work in starting.

The steam car would be freer from the objection of noise; but, like the gasoline car, it has the disadvantage of taking more time to start after a stop than does the electric.

Where a physician has to do much traveling over rough roads, or his mileage exceeds the limit of the electric vehicle, the gasoline run-about would be the next choice for him.

CLASS 4. *A vehicle owned by a business establishment for purposes of transportation and entertainment of customers and guests.*

Business concerns whose single sales amount to a considerable sum, and who need to entertain prospective customers at headquarters, have found the automobile a great aid to their sales departments. Whether a vehicle of this sort shall partake more of the characteristics of a high-class omnibus or coach, or whether it shall be a high-power, high-speed car, will depend on the number of passengers to be taken, and whether the car will be used primarily as a conveyance or for entertainment.

If the car is to be used primarily as a conveyance, and passes through city streets, it is well to bear in mind that a very long wheel-base is a disadvantage in turning corners and in driving through crowded streets.

If the car is to be used primarily for entertainment of a few people, it will come into Class 6, the pleasure vehicle.

CLASS 5. *A family vehicle for pleasure drives.*

In this class it is important that the car possess ability to stand considerable strain for a short time. The car is likely to be used Saturdays and Sundays for country tours. If the owner is not a man of mechanical experience, and is his own driver, it is important that he look to simplicity and accessibility of parts in his car. He will find abundant pleasure in tours of not over a hundred miles a day. With this mileage as a gauge, he will not need to buy a car of high horse-power. Twenty to twenty-five horse-power actually developed, will answer his requirements.

The gasoline car and the steam car are the only ones to be considered in this class. Good two-cylinder cars are built that come under this class.

Still lighter cars than above indicated have been used successfully for this service by people who take care in selecting the weather and the roads.

A comfortable, modest-looking vehicle with sufficient power to maintain a speed of twenty miles an hour, amply silenced, with side

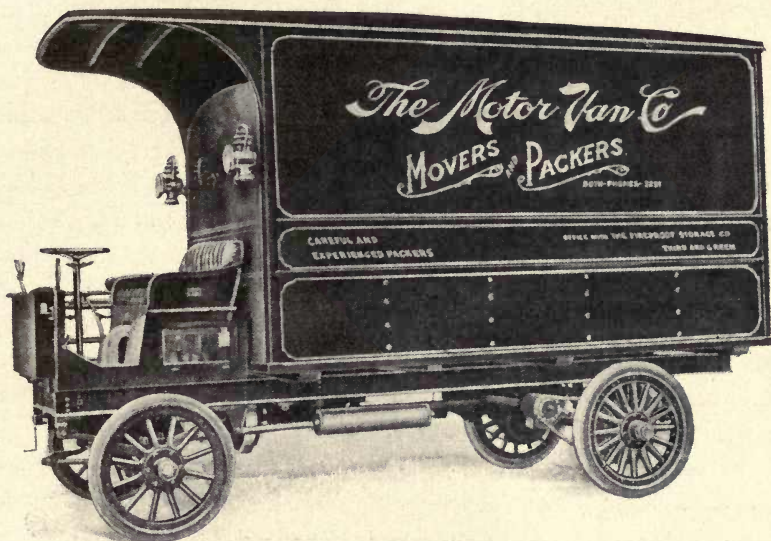

Fig. 181. Frayer-Miller Motor-Van.
Capacity 3 Tons; 24-Horse-Power.
Oscar Lear Automobile Company, Springfield, Ohio.

entrances, is the type of car that will answer this purpose. By all means, such a vehicle needs a top.

CLASS 6. *A vehicle for sport on land, corresponding to the power yacht in water.*

The purchaser of this class of vehicle will probably be in the market every year for the very latest and most improved vehicle to be obtained, which will probably without question be a gasoline car of at least 30-horse-power capacity. The purchaser of this type of car wants speed, endurance, and power. Hence he will study the chassis—namely, the frame with the driving mechanism, stripped

of all accessories and externals. The external features, although pleasing to the eye, are but coverings to the machine itself; and having once selected the machine wanted, he can have it fitted up in a way to suit the most fastidious, provided he places his order early enough.

CLASS 7. *Light delivery wagon.*

For delivery of light goods, the motor-car has by no means come into the general use which it is likely to have within a few years. The builders of electric vehicles have up to this time been the ones to exploit this market, but there is abundant opportunity in this field for gasoline cars of moderate horse-power.

CLASS 8. *Trucks; Drays; Vans.*

Low gear, long wheel-base, and chain drive (usually double-chain) characterize this class of car. Although the electric automobile manufacturers were the first to enter this field, gasoline-driven cars of this type are now appearing in large numbers.

CLASS 9. *Omnibuses; Stages.*

Both steam and gasoline cars are used for this purpose. Much dissatisfaction and agitation were caused in London by the large number of accidents due to this class of vehicle, mainly owing to their too high speed and poor control. These objections must be overcome in a successful auto-bus.

CLASS 10. *Motor-driven railway coaches.*

Chiefly electric or gasoline-driven. Are coming into use on short branch lines and for suburban traffic in railway service.

INDEX

A		Page
Accessories, automobile.....		177
Advancing spark		80
Air-cooled engine.....		37
Auto-Bus.....		177, 181
Axles.....		9
B		
Back-firing.....		127
Balance gears		104
Batteries, storage.....	140, 143,	146
Bearings.....		116
Body of motor-car.....		5
Brakes.....		114
Brougham.....		162, 179
Buckboard.....		156, 179
C		
Cabriolet.....		174, 180
Cadillac carbureter.....		57
Carbureters.....		55, 59
directions for connecting and adjusting to motor.....		61
Chain drive.....	10,	99
Changing gears.....		98
Charging storage batteries.....		140
Chauffeurs.....		175
Classification of motor-cars.....		179
Cleaning.....		131
Clothing of automobilist.....		176
Clutches		
disc.....		87
metallic constriction-band.....		85
Clutch drive.....		10
Clutch lever.....		86
Commercial vehicles.....		181
Compensating carbureters.....		59
Compression-relief levers.....		83
Cooling systems		
air-cooling.....		37
gasoline.....		51
water-cooling.....	43,	51
Copper-asbestos gaskets.....		48

	Page
Corrosion in cylinders.....	37
Coupé.....	162, 179
Crank-shaft.....	27
Cycle, gas-engine.....	18
Cylinders, engine.....	24
Cylindrical bronze bearings.....	116

D

Delivery car.....	176, 181
Delivery wagon.....	175, 181
Demonstrations of cars.....	165
Differentials.....	104
Direct-current shunt-wound dynamo system of ignition.....	68
Direct drive.....	10, 99
Disc clutches.....	87
Dos-à-Dos.....	161, 179
Drays, see Trucks	
Drive.....	10, 99
Driving a car, instruction in.....	170
Dry-cell and jump-spark system of ignition.....	63
Dynamos on motor-cars.....	68

E

Electric vehicles.....	136
care of motor.....	139
charging stations.....	140
driving.....	138
storage batteries for.....	143
Elliptical springs, full and half.....	8, 9
Emergency hand-brake.....	115
Engine	
cooling of.....	37
overheating of.....	50
principal parts of.....	25
single- and multiple-cylinder.....	24
starting.....	120
suggestions for operating.....	123
two-cycle.....	20
working parts of.....	21
Engine-controlling mechanism	
compression-relief levers.....	83
muffler cut-out.....	83
spark-lever.....	79
throttle-lever.....	80
Escaping water.....	127
Explosions.....	127

F

Family vehicles.....	184
----------------------	-----

	Page
Float-feed type of carbureter.....	57
Floating type of axle.....	10
Float valves, leaky.....	62
Flow motor in steam car.....	153
Frame of motor-car.....	5
Freezing, protection against.....	51
Fuel regulation in steam cars.....	153

G

Gas-engine cycle.....	18
Gaskets.....	47
Gasoline, grades of.....	55
Gasoline and air, proper mixture of.....	60
Gasoline system.....	51
Gasoline tank.....	53
Gears, changing.....	91, 98, 171
Generator sets.....	141

H

Heating, excessive.....	50
High-speed gear, running on.....	98
Hills, climbing and descending.....	130, 174
Horse-power and weight of cars.....	167
Hyatt roller bearing.....	118

I

Ignition systems	
dry-cell and jump-spark.....	63
dynamos for charging batteries.....	68
make-and-break system.....	75
spark-plugs.....	73
storage batteries.....	77
Inflation of tires.....	132

K

Knocking of engine.....	125
Knuckle, steering.....	12

L

Lack of speed in engine.....	125
Ladies' carriages.....	182
Lamps.....	179
Landaulet.....	172, 180
Leaky float-valves.....	62
Levers.....	85, 94, 172
Limousine.....	170, 171, 180
Loss of power in engine.....	123
Lubricating instructions	
daily oil and grease.....	111

	Page
Lubricating instructions	
differential gears	114
oil in crank-case	113
transmission	113
universal joints	114
wheels	114
Lubrication	106
Lubricators, mechanically operated	108
M	
Magneto	70
Make-and-break system of ignition	75
Mayo cellular radiator	46
Metallic constriction-band clutches	85
Mixture, explosive, of gasoline and air	60
Motor-cars	
body	5
classification of	179
power plant	4, 17
running gear	1
selecting	155
Motor-generator sets	141
Motor suspension	7
Muffler cut-out	83
N	
Neck, or vertical steering spindle	12
New car, what to do to	119
Noise	126
O	
Oil and oiling	106
Omnibus	177, 181
Overheating of engine	50
P	
Passenger vehicles	179
Pedals, see Levers	
Physician's car	183
Planetary gears	91
Planetary transmission	85
Power plant of motor-car	4, 17
gas-engine cycle	18
two-cycle engines	20
Power-transmission devices	
clutches	85
drive	99
speed-changing gears	91
Price of a car	158
Pullman	173, 180

R		Page
Racing of engine		125
Radiators		45, 51
Railway coaches, motor-driven		186
Reach rod		14
Rear axles		9
Reo tubular radiator		46
Retarding spark		80
Revolving-cylinder motor		43
Road inspection		131
Roadster		167, 180
Runabout		157, 158, 159, 179
Running gear of motor-car		1
Running on high-speed gear		98
S		
Second-hand cars		160, 163
Selecting a motor-car		155
Semi-elliptical springs		8
Shaft drive		10, 99
Single- and multiple-cylinder engines		24
Skidding		128
Sliding gears		92
Smoke		128
Spark-coil, adjustment of		66
Spark-lever		79
Spark-plugs		73
Speed-changing gears		
planetary		91
sliding		92
Speed-changing levers operating sliding gears		94
Sportabout		168, 180
Spring-hangers		7
Springs		8
Stage		180
Stanhope		160, 179
Steam-driven automobiles		147
Steaming radiators		51
Steering connections		13
Steering gear		14, 175
Steering knuckle		12
Steering yoke		12
Storage batteries for electric vehicles		140, 143
care of		146
charging		140, 143
Storage batteries for ignition purposes		77
Surrey		164, 180
T		
Taxicab		169, 180

	Page
Thermo-siphon method of cooling.....	46
Throttle-lever.....	80
Timing of valves.....	34
Timken roller bearing.....	117
Tire inflation.....	132
Tires, care of.....	131
inflation of.....	132
puncture of.....	135
to remove from rim and replace.....	134, 135
weights carried by.....	133
Tops for cars.....	177
Touring car.....	165, 166, 180
Trembler, see Vibrator	
Troubles of engine.....	123
Trucks.....	181, 183, 186
Two-cycle engines.....	20
Two-cylinder opposed engine.....	38
U	
Universal joints.....	101
Uses of cars.....	182
V	
Valve setting.....	34
Valves.....	30
care and operation of.....	32
Van.....	185, 186
Vertical steering spindle or neck.....	12
Vibrator, action of.....	65
Victoria.....	164
Volt-ammeter.....	136
W	
Washing.....	131
Water-cooled engines.....	43
care of.....	51
Water regulation in steam cars.....	152
Water system in steam car.....	155
Weak batteries.....	125
Weight and horse-power of cars.....	167
Working parts of engine.....	21



UNIVERSITY OF CALIFORNIA LIBRARY
BERKELEY

Return to desk from which borrowed.
This book is due on the last date stamped below.

DEC 17 1947
31 Dec '48 WM

7 Feb '49 JS

7 Oct '49 CS

7 Oct '49 CS

16 Feb '50 A

8 Aug DEAD

15 Apr '52 KU

1 Apr '52 LU

8 Jan '58 RWN

JAN 13 1958

LD 21-100m-9,'47 (A)

HOME USE
CIRCULATION DEPARTMENT
MAIN LIBRARY

This book is due on the last date stamped below.
1-month loans may be renewed by calling 642-3405.
6-month loans may be recharged by bringing books
to Circulation Desk.

Renewals and recharges may be made 4 days prior
to due date.

ALL BOOKS ARE SUBJECT TO RECALL 7 DAYS
AFTER DATE CHECKED OUT.

MAR 26 1976 APR 07 1989
REC. CIRC. APR 5 - 1987
MAY 3 1987

AUTO DISC APR 14 '87

APR 15 1988

MAY 01 1988

AUTO DISC MAR 17 1988

AUTO DISC APR 26 1988

APR 30 1989

LD21-A-40m-8,'75
(S7737L)

General Library
University of California
Berkeley

U.C. BERKELEY LIBRARIES



8003017524

TL 145

A 5

179721

UNIVERSITY OF CALIFORNIA LIBRARY

