

Digitized by the Internet Archive  
in 2007 with funding from  
Microsoft Corporation

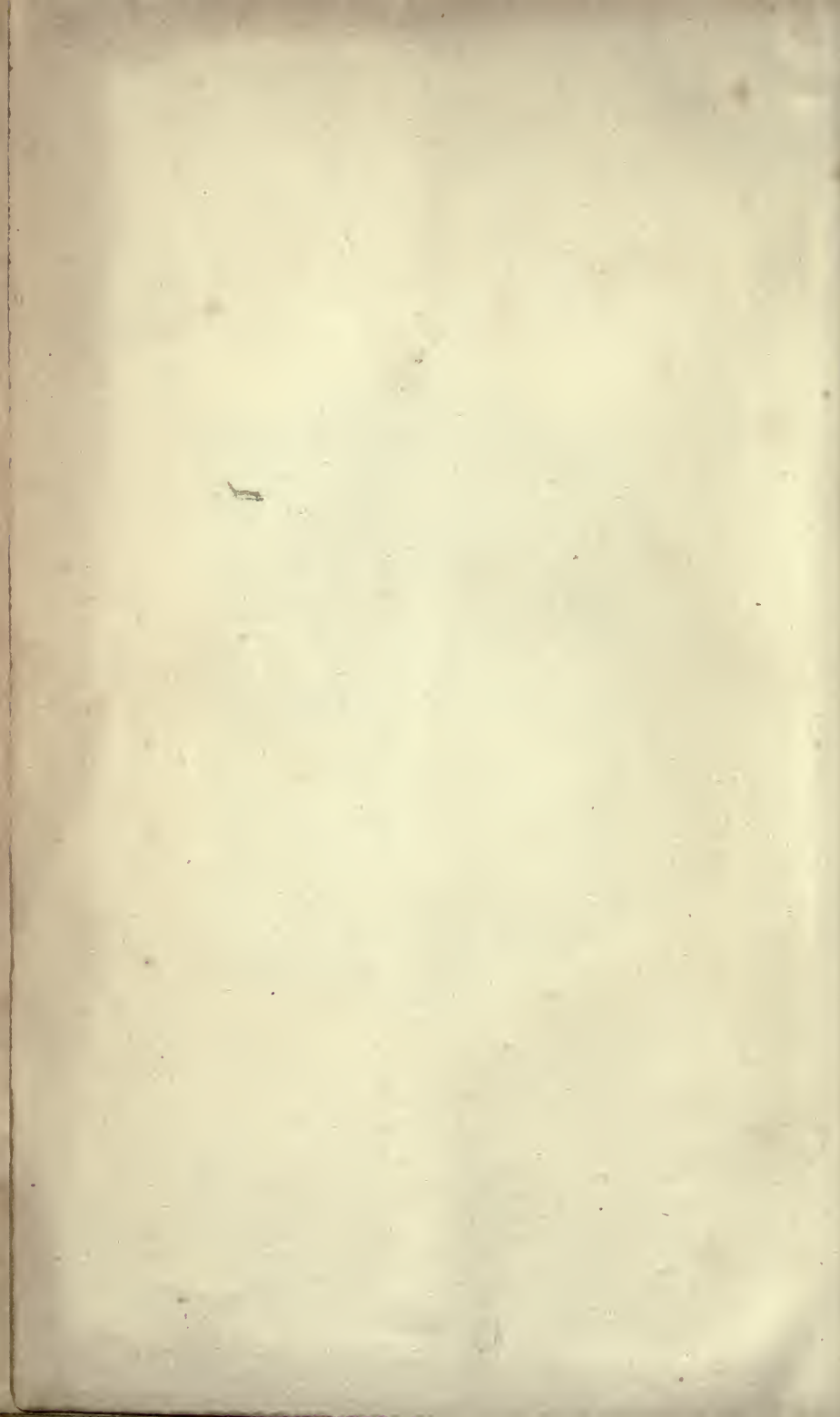





AN  
ENCYCLOPÆDIA  
OF  
AGRICULTURE;

COMPRISING THE  
*THEORY AND PRACTICE*  
OF THE VALUATION, TRANSFER, LAYING OUT, IMPROVEMENT, AND  
MANAGEMENT OF

LANDED PROPERTY;

AND THE CULTIVATION AND ECONOMY OF  
THE ANIMAL AND VEGETABLE PRODUCTIONS  
OF AGRICULTURE,

INCLUDING

*All the latest Improvements;*

A GENERAL HISTORY OF AGRICULTURE IN ALL COUNTRIES;

AND A STATISTICAL VIEW OF ITS PRESENT STATE,  
WITH SUGGESTIONS FOR ITS FUTURE PROGRESS IN THE  
BRITISH ISLES.

---

By J. C. LOUDON, F.L.S., H.S., &c.

AUTHOR OF THE ENCYCLOPEDIA OF GARDENING.

---

ILLUSTRATED WITH  
UPWARDS OF EIGHT HUNDRED ENGRAVINGS ON WOOD BY BRANSTON.

---

LONDON:

PRINTED FOR  
LONGMAN, HURST, REES, ORME, BROWN, AND GREEN,  
PATERNOSTER-BOW;

AND SOLD BY CAREY AND LEA, PHILADELPHIA.

1826.

*Bot*



5493  
L8  
1826

## PREFACE.

---

THOUGH the title of this work is sufficiently comprehensive, it may not be improper to state the grounds on which it lays claim to being the most complete body of Agriculture hitherto submitted to the public.

The subject of Agriculture admits of two grand divisions; the improvement and general management of landed property, which may be termed *Territorial Economy*; and the cultivation and treatment of its more useful animal and vegetable productions, which is called *Husbandry*, or *Agriculture* in a more limited sense of the term. Numerous as have been the publications on rural matters during the last twenty years, there are but two or three of them, whose titles might lead to a supposition that they embraced both of these departments. Of these, two may be cited: the *Complete Farmer*, as the most extensive, and the *Code of Agriculture*, as the most recent. The *Complete Farmer*, or *Dictionary of Husbandry*, in two thick quarto volumes, with numerous plates, was published in 1807; it is copious to an excess, containing an immense mass of matter, new and old, good and bad. As a dictionary of Husbandry, it was the best of its kind at the time of its publication: but the rapid progress of Agriculture since its date, renders it at the present time quite an obsolete work. The *Code of Agriculture*, in one volume octavo, published in 1817, professes to be "a general view of the principles of the art, and an account of its most approved practices." (*Pref.* p. xi.) By inspecting the contents of the work, however, it will be found limited to the Husbandry Department; and of that to contain little more than a general outline. That it never was intended as more than a book on Farming, its first chapter, "On the Preliminary Points which a Farmer ought to consider, &c.," and an observation of its author in his preface, sufficiently shews: "in addition," he states, "(to the Code) it would certainly be desirable to have a separate work on the *Minutiæ* of Farming," "which," he continues, "might be accomplished in another volume of a similar size." (*Pref.* p. xi.) The *Code of Agriculture*, therefore, has no other pretensions to being a complete view of the subject, than what the imagination may confer from the quaintness of its title. By this title it has been alleged, the author probably intended, "some allusion to the Code Napoleon, some mysterious reference to a body of laws, and some modest preten-

sions to the character of an Agricultural Lawgiver." (*Farmer's Mag.* vol. xviii. p. 78.) The Code, however, has great merit as a collection of useful precepts on Farming; but not being a complete view of its subject; and the Complete Farmer being obsolete, there remained ample room for a performance such as we have undertaken.

This work, which we have termed an *Encyclopædia of Agriculture*, on account of its comprehensiveness, professes to embrace every part of the subject; and what has never hitherto been attempted, a general History of Agriculture in all countries, and a condensed survey of its present state in every county of the British Isles. We have adopted a systematic arrangement as by far the best for instruction, and also as best admitting of compression; and we have at the same time supplied a copious General Index to render the whole of the easiest access as a book of reference. All this could only be accomplished by a very copious page, and the liberal use of engravings. By these means, much verbal description is avoided, ideas more forcibly expressed, and such a body of useful matter included in one volume as, by the system of detached copperplate engravings, and ordinary letter press, would have occupied half a dozen, and been high priced in proportion.

Throughout this work, we have kept in view the following objects: in PART I., to depict Agriculture in the most universal sense, by giving a view of that of all countries; in PART II., to depict the principles on which the operations and results of the Agriculture of all countries are founded; and in PARTS III. and IV., to apply these principles to that particular Agriculture which is practised in Britain, and similar climates. In pursuing these objects, we have aimed at language sufficiently free from provincial or obscure technology to be understood by all classes of readers. In depicting the Agriculture of Britain, we have held up to view that of the northern counties of Northumberland, Berwickshire, and East Lothian as examples, in most things, to the other parts of the empire. In addressing landlords, superior agents, valuers, and patrons, to point out the advantages of equitable and liberal conduct to their tenants and dependants; in discussing the duties of land stewards, bailiffs, and other serving agriculturists, to recommend habits of order, vigilance, and economy; and finally, submitting to all classes of readers, the advantages of enlightening the minds and ameliorating the condition of the operative classes, by facilitating the attainment of instruction: pointing out the evils of early marriages; increasing the comfort and improving the appearance of their cottages and gardens; and, especially, by repaying their labor to a certain extent in productions calculated for their chief support. (See § 3841. and 4496.) For in our opinion the peculiar comfort of all those engaged in agriculture as a profession, from the laborer to the gentleman farmer, will ever consist more in *the possession within themselves of the essential means of comfortable existence*, than of



the power of accumulating fortunes, such as manufacturers and commercial men frequently acquire.

As much of the value of a work of this kind will depend on the knowledge it conveys of the modern improvements in implements and buildings, particular attention has been paid to these subjects. Three-fourths of the implements and edifices of which engravings are given in Dr. Dickson's *Practical Agriculture*, and the *Complete Farmer*, may be considered as obsolete, or greatly altered by subsequent improvements. Many of these improvements have not found their way into any books, and for them we have had recourse to the originals, and to the most eminent Agricultural mechanics and manufacturers of implements: Our thanks in this respect are particularly due to the proprietors of Weir's Agricultural Repository, Oxford-Street, London, for permitting us to take sketches from their extensive collection, and more particularly of those implements and machines which the late Mr. Weir invented or greatly improved. Our best thanks are also due to Mr. Morton, Leith-walk, Edinburgh, who is equally eminent as an Agricultural mechanist in Scotland. There is no implement or machine mentioned in this work which will not be found on sale, or may not be made to order in the establishments alluded to, in the best manner, and at an equitable charge.

For important assistance in the Veterinary part of this work, our best thanks are due to an eminent professor. Through the kind assistance of this gentleman we have been enabled to bring together a body of popular information on the anatomy, physiology, pathology, breeding, rearing, and general treatment of the horse, the ox, the sheep, and other domestic animals, even to dogs and poultry, as we can safely assert is not to be found in any other Agricultural publication.

It remains only to mention as a key to this work, that such technical terms as are used in a more definite sense than usual, are explained at the end of this preface; such as are not common in general language, in the index; and the abridged titles of books, or of proper names, are there also given at length. The systematic nomenclature of plants adopted, is that of our *Encyclopædia of Plants* and *Hortus Britannicus*, now in great part through the press, with some exceptions which are noted where they occur. In the specific names of animals, we have followed Turton's edition of the *Systema Naturæ* of Linnæus: such chemical, mineralogical, and geological terms as occur, are those used by Sir H. Davy in his *Agricultural Chemistry*, and by Professor Brande in his *Geology*: and the weights and measures are always after the standard of England, unless otherwise expressed. More accuracy and consistency, it is hoped, has been attained in these particulars, than is usual in even the best Agricultural works; the dry rot is not here described as "a plant with leaves like the misletoe," as in

the *Complete Farmer*; clover is not called a grass, the Scotch pine a fir, or tubers roots, as in the *Code*; earth, soil, and mould are not confounded as in most farming books; and no cultivator is here told, as he is in Arthur Young's *Farmers' Kalendar* (*May*, art. *Hemp*, 1st edit. 1790, 12th edit. 1823.) to make the rent per acre a criterion in choosing a soil for any plant.

The recent changes, indeed, which have taken place in the market value of currency, render price a criterion of much too temporary a nature to be employed in any work which aims at general and permanent utility. For this reason we have in the Encyclopædia generally avoided money calculations, indicating the value of objects or operations by the quantity of materials and labor requisite to produce them; or by stating their cost relatively to the cost of other articles.

We have also avoided entering on the subject of state policy, as to the relative protection of Agriculture and manufactures, or of the protection of the home against the foreign grower of corn. Natural prices will always be safer for the farmer than artificial ones, and with low prices the farmer has the chance of deriving a greater benefit on an extraordinary rise, and sustaining less loss on an extraordinary fall. If the prices of corn were one half lower than they are, neither farmers nor proprietors would find their comforts diminished; for the value of manufactures and importations would fall in proportion to that of Agricultural produce. Price, it is true, is not always value; but they are never materially different for any length of time.

By referring to the Kalendarial Index, those parts of this work which treat of farm and forest culture, and management, may be consulted monthly as the operations require to be performed; and by recurring to the General Index, any particular subject may be traced alphabetically through all its ramifications of history, theory, practice, and statistics. Thus we have here combined an Agricultural Treatise, a Husbandman's Kalendar, and a Dictionary of Rural Affairs.

J. C. L.

*Bayswater, June 19, 1825.*

## THE FOLLOWING TERMS

Being frequently used in a vague and indefinite manner, it will be of advantage to the reader to know beforehand the sense in which they are applied in this work. Other terms of less frequent use, or of various meaning, are explained in an alphabetical order in the General Index.

*Agriculture* is used in its most extensive sense in the third line of the title page, and generally in the Historical part of the work (Part I.) as including territorial economy and husbandry.

In *most parts of this work*, for example, in the words of the title page, "animal and vegetable productions of Agriculture," as synonymous with husbandry.

In *several places* as synonymous with aration, that is, the culture of arable lands, as opposed to pasturage, or what may be called Agriculture proper. In every case the reader will be able to gather from the scope of the sentence or paragraph containing this term, in which of these three senses it is meant to be understood.

*Territorial economy*, what relates to the valuation, purchase, sale, exchange, arrangement, improvement by roads, canals, drainage, &c., of territorial surface, including interposing waters, as rivers, lakes, and also mines and minerals. Territorial improvements are mostly effected by the proprietors of lands or their agents and stewards, and not to any great extent by renters of land, or farmers.

*Husbandry*, the culture of arable grass and woodlands, the management of live stock, the dairy, poultry, &c., and, in general, what constitutes the business of the head of a family living by agricultural industry in the country.

*Rural economy*, rural affairs, geponics, agronomics, terms considered as synonymous with husbandry.

*Farming*, renting land and cultivating it, or employing it for the purposes of husbandry.

*Farmer* (from *fermier*, Fr.), farming agriculturist, farming cultivator, professional farmer, commercial farmer, rent-paying farmer, &c.; a proprietor cultivating his own estate, is not correctly speaking a farmer, to be such he must pay a rent. A proprietor who cultivates his own soil may be a gentleman or yeoman agriculturist or husbandman, a *proprietaire cultivateur*, but not a farmer.

*Husbandman*, one who farms generally; that is, who both produces corn and cattle, and attends to the dairy, the poultry, the woodlands, and the orchard. A farmer may confine himself to grazing, or to breeding or haymaking, or milking or raising green crops for the market, &c., but in none of these cases can he with propriety be called a husbandman. This term husbandman therefore is not exactly synonymous with farmer.

*Grasses*, all the natural order of Gramineæ, of Linnæus and Jussieu.

*Cereal grasses*, those grown for bread corn.

*Pasture grasses*, those grown chiefly for pasturage.

*Fœniculous grasses*, those grown chiefly for hay.

*Herbage plants*, clover and other plants cultivated chiefly for the herb, to be used either green or made into hay.

*Foliage crops*, plants cultivated for their leaves to be used green, and which will not make into hay, as the cabbage tribe.

*Root crops*, esculent plants cultivated for their tubers, bulbs, or other enlarged parts produced under or immediately on the ground, and chiefly connected with the root, as the potatoe, turnip, carrot, &c.

*Roots*, the fibres and other ramifications of a plant under ground, and by which it imbibes nourishment. Tubers, bulbs, and other fleshy protuberances under ground, are employed by nature for the purposes of propagation or continuation, and therefore

ought never to be confounded with common roots, which serve to nourish these tubers, bulbs, &c., in common with other parts of the plant.

*Earth*, as applied to the surface of the globe, one or more of the earths, as lime, clay, sand, &c., in a friable or divided state, and either alone or mixed; but without the addition of much organic matter.

*Soil*, earth, either of one, or of several sorts, mixed with decomposed organic matters.

*Mould*, organic matter in a finely divided and decomposed state, with a little earth mixed, as vegetable mould, leaf mould, peat mould, &c.

*Loam*, any soil in which clay and organic matter exist in considerable proportions, and so as to render it neither very adhesive or hard, or soft and loose.

*Land*; ground, earthy surface in opposition to water or rocks; the term ground is generally applied to a comparatively limited extent of surface, as garden grounds, hop grounds, &c. in opposition to arable lands, wood lands, &c.

# CONTENTS.

## PART I.

### AGRICULTURE CONSIDERED AS TO ITS ORIGIN, PROGRESS, AND PRESENT STATE, AMONG DIFFERENT NATIONS, GOVERNMENTS, AND CLIMATES.

#### BOOK I.

##### HISTORY OF AGRICULTURE AMONG ANCIENT AND MODERN NATIONS.

CHAP. I.	Page
Of the History of Agriculture in the Ages of Antiquity; or from the Deluge to the Establishment of the Roman Empire in the century preceding the vulgar æra	4
I. Of the Agriculture of Egypt	5
II. Of the Agriculture of the Greeks	7
III. Of the Agriculture of the Jews, and other Nations of Antiquity	9

##### CHAP. II.

History of Agriculture among the Romans, or from the Second Century B. C. to the Fifth Century of our æra	12
I. Of the Roman Agricultural Writers	<i>ib.</i>
II. Of the Proprietorship, Occupancy, and General Management of Landed Property among the Romans	13
III. Of the Surface, Soil, Climate, and other Agricultural Circumstances of Italy, during the time of the Romans	16
IV. Of the Culture and Farm Management of the Romans	17
1. Of the Choice of a Farm, and of the Villa or Farmery	<i>ib.</i>
2. Of the Servants employed in Roman Agriculture	19
3. Of the Beasts of Labor used by the Romans	21
4. Of the Agricultural Implements of the Romans	23
5. Of the Agricultural Operations of the Romans	25
6. Of the Crops cultivated, and Animals reared by the Romans	29
7. Of the General Maxims of Farm Management among the Romans	30
V. Of the Produce and Profit of Roman Agriculture	31
VI. Of the Roman Agriculturists, in respect to general Science, and the Advancement of the Art	32
VII. Of the Extent to which Agriculture was carried in the Roman Provinces, and of its Decline	33

##### CHAP. III.

History of Agriculture during the Middle Ages, or from the Fifth to the Seventeenth Century	<i>ib.</i>
I. History of Agriculture in Italy during the Middle Ages	34
II. History of Agriculture in France from the Fifth to the Seventeenth Century	35
III. Of the Agriculture of Germany and other Northern States from the Fifth to the Seventeenth Century	<i>ib.</i>
IV. History of Agriculture in Britain from the Fifth to the Seventeenth Century	36
1. History of Agriculture in Britain during the Anglo-Saxon Dynasty, or from the Fifth to the Eleventh Century	<i>ib.</i>

	Page
2. Of the State of Agriculture in Britain after the Norman Conquest, or from the Eleventh to the Thirteenth Century	37
3. History of Agriculture in Britain from the Thirteenth to the Seventeenth Century	40
4. History of Agriculture from the Death of Henry VIII. in 1547, to the Revolution in 1688	41
V. History of Agriculture in ultra European Countries during the Middle Ages	47

##### CHAP. IV.

Present State of Agriculture in Europe	48
I. Of the Present State of Agriculture in Italy	<i>ib.</i>
1. Of the Agriculture of Lombardy	<i>ib.</i>
2. Of the Agriculture of Tuscany	51
3. Of the Agriculture of the Maremmes, or the District of Pestilential Air	55
4. Farming in the Neapolitan Territory, or the Land of Ashes	57
II. Of the Present State of Agriculture in Switzerland	59
1. Of the Agriculture of the Swiss Cantons	<i>ib.</i>
2. Agriculture of the Duchy of Savoy	62
III. Of the present State of Agriculture in France	65
1. Progress of French Agriculture from the time of Louis XIV. to the present Time	<i>ib.</i>
2. Of the general Circumstances of France in respect to Agriculture	66
3. Of the common Farming of France	67
4. Farming in the warmer Climates of France	70
IV. Present State of Agriculture in Holland and the Netherlands	79
1. Present State of Agriculture in Holland	<i>ib.</i>
2. Present State of Agriculture in the Netherlands	73
V. Present State of Agriculture in Germany	87
1. General View of the Agricultural Circumstances of Germany	<i>ib.</i>
2. Agriculture of the Kingdom of Denmark, including Greenland and Iceland	89
3. Agriculture of the Kingdom of Prussia	90
4. Agriculture of the Kingdom of Hanover	93
5. Present State of the Agriculture of Saxony	95
6. Present State of the Agriculture of the Kingdom of Bavaria	96
7. Present State of the Agriculture of the Empire of Austria	<i>ib.</i>
VI. Of the present State of Agriculture in the Kingdom of Poland	100
VII. Present State of the Agriculture of Russia	104
VIII. Present State of the Agriculture of Sweden and Norway	108
IX. Present State of the Agriculture of Spain and Portugal	113
1. Present State of Agriculture in European Turkey	120

##### CHAP. V.

Modern History and present State of Agriculture in the British Isles	122
I. Political History of Agriculture in Britain from the Revolution in 1688, to the present Time	123

	Page		Page
1. Professional History of Agriculture, from the Revolution to the present Time	- 125	6. Present State of Agriculture on the Eastern Coast of Africa, and the African Islands	- 182
2. Of the Literature of British Agriculture from the Revolution to the present Time	130	III. Present State of Agriculture in North America	- 184
3. Of the Rise, Progress, and present State of Agriculture in Ireland	- 132	1. Present State of Agriculture in the United States	- <i>ib.</i>
CHAP. VI.			
Present State of Agriculture in Ultra European Countries	- 138	2. Present State of Agriculture in Mexico	- 189
I. Present State of Agriculture in Asia	- <i>ib.</i>	3. Present State of Agriculture in the British Possessions of North America	191
1. Present State of Agriculture in Asiatic Turkey	- 139	4. Present State of Agriculture in the West India Islands	- 192
2. Present State of Agriculture in Persia	- <i>ib.</i>	IV. Present State of Agriculture in South America	- 198
3. Present State of Agriculture in Independent Tatory	- 143		
4. Present State of Agriculture in Arabia	- <i>ib.</i>		
5. Present State of Agriculture in Hindustan	145		
6. Of the Agriculture of the Island of Ceylon	151		
7. Present State of Agriculture in the Birman Empire, in Java, Malacca, Siam, Cochinchina, Tonquin, Japan, &c.	- 152		
8. Present State of Agriculture in the Chinese Empire	- 157		
9. Present State of Agriculture in Chinese Tatory, Thibet, and Bootan	- 163		
10. Present State of Agriculture in the Asiatic Islands, including also those of Australasia and Polynesia	- 166		
II. Present State of Agriculture in Africa	170		
1. Present State of Agriculture in Abyssinia	- <i>ib.</i>		
2. Present State of Agriculture in Egypt	171		
3. Present State of Agriculture in the Mahometan States of the North of Africa	- 175		
4. Present State of Agriculture on the Western Coast of Africa	- 177		
5. Present State of Agriculture at the Cape of Good Hope	- 178		

BOOK II.

AGRICULTURE AS INFLUENCED BY GEOGRAPHICAL, PHYSICAL, CIVIL, AND POLITICAL CIRCUMSTANCES.

CHAP. I.	
Agriculture as influenced by Geographical Circumstances	- 202
CHAP. II.	
Agriculture as influenced by Physical Circumstances	- 203
CHAP. III.	
Agriculture as affected by Civil, Political, and Religious Circumstances	- 205
CHAP. IV.	
Of the Agriculture of Britain	- 207

PART II.

AGRICULTURE CONSIDERED AS A SCIENCE.

BOOK I.

OF THE STUDY OF THE VEGETABLE KINGDOM WITH A VIEW TO AGRICULTURE.

CHAP. I.	
Of the Study of Systematic Botany	- 208
CHAP. II.	
Vegetable Anatomy, or the Structure and Organization of Plants	- 210
I. Of the External Structure of Perfect Plants	- <i>ib.</i>
II. Of the External Structure of Imperfect Plants	- 211
III. Of the Internal Structure of Plants	- 213
1. Decomposite Organs	- <i>ib.</i>
2. Composite Organs	- 214
3. Elementary or Vascular Organs	- 215
CHAP. III.	
Vegetable Chemistry, or Primary Principles of Plants	- 216
I. Compound Products	- 217
II. Simple Products	- 226
CHAP. IV.	
Functions of Vegetables	- <i>ib.</i>
I. Germination of the Seed	- <i>ib.</i>
II. Food of the Vegetating Plant	- 228
III. Process of Vegetable Nutrition	- 233
IV. Process of Vegetable Development	- 240
V. Anomalies of Vegetable Development	- 244
VI. Of the Sexuality of Vegetables	- 248
VII. Impregnation of the Seed	- 249
VIII. Changes consequent upon Impregnation	- 250
IX. The Propagation of the Species	- 251
X. Causes limiting the Propagation of the Species	- 253
XI. Evidence and Character of Vegetable Vitality	- 254
CHAP. V.	
Vegetable Pathology, or the Diseases and Casualties of Vegetable Life	- 258
I. Wounds and Accidents	- <i>ib.</i>

II. Diseases	- 259
III. Natural Decay	- 262

CHAP. VI.

Vegetable Geography and History, or the Distribution of Vegetables relatively to the Earth and to Man	- 263
I. Geographical Distribution of Vegetables	- 264
II. Physical Distribution of Vegetables	- <i>ib.</i>
III. Civil Causes affecting the Distribution of Plants	- 269
IV. Characteristic or Picturesque Distribution of Vegetables	- 270
V. Systematic Distribution of Vegetables	- 271
VI. Economical Distribution of Vegetables	- 272
VII. Arithmetical Distribution of Vegetables	- 273
VIII. Distribution of the British Flora, indigenous and exotic	- <i>ib.</i>

CHAP. VII.

Origin and Principles of Culture as derived from the Study of Vegetables	- 277
--	-------

BOOK II.

OF THE STUDY OF THE ANIMAL KINGDOM WITH REFERENCE TO AGRICULTURE.

CHAP. I.	
Systematic Zoology, or the Language, Nomenclature, Description, and Classification of Animals	- 280
CHAP. II.	
Animal Anatomy	- 282
I. External Anatomy of Animals	- <i>ib.</i>
II. Internal Anatomy of Animals	- 284
1. Osseous Structure of Animals	- <i>ib.</i>
2. Muscular Structure of Animals	- 285
3. Structure of the Nervous System	- 287
CHAP. III.	
Animal Chemistry; or the Substances which enter into the Composition of the Bodies of Animals	- 288

CHAP. IV.	Page
Animal Physiology - - -	- 291
I. Of the Digestive System - - -	- <i>ib.</i>
II. Of the Circulating System - - -	- <i>ib.</i>
III. Of the reproductive System of Animals - - -	- 292

CHAP. V.	
Animal Pathology; or the Duration, Diseases, and Casualties of Animal Life - - -	- 293

CHAP. VI.	
Of the Distribution of Animals - - -	- 295

CHAP. VII.	
Of the Economical Uses of Animals - - -	- 298

CHAP. VIII.	
Principles of improving the Domestic Animals used in Agriculture - - -	- 299
I. Of improving the Breed of Animals - - -	- <i>ib.</i>
II. Of the general Principles of rearing, managing, and feeding Domestic Animals - - -	- 302
III. Of Feeding for Extraordinary Purposes - - -	- 305
IV. Of the Modes of killing Animals - - -	- 307

BOOK III.

OF THE STUDY OF THE MINERAL KINGDOM AND THE ATMOSPHERE, WITH REFERENCE TO AGRICULTURE.

CHAP. I.	
Of Earths and Soils - - -	- 308
I. Of the Geological Structure of the Globe and the Formation of Earths and Soils - - -	- <i>ib.</i>
II. Classification and Noemclature of Soils - - -	- 310
III. Of discovering the Qualities of Soils - - -	- 312
1. Of discovering the Qualities of Soils by means of the Plants which grow on them - - -	- <i>ib.</i>
2. Of discovering the Qualities of Soils by Chemical Analysis - - -	- 313
3. Of discovering the Qualities of a Soil mechanically and empirically - - -	- 314
IV. Of the Uses of the Soil to Vegetables - - -	- 315
V. Of the Improvement of Soils - - -	- 318
1. Pulverisation - - -	- <i>ib.</i>
2. Of the Improvement of Soils by Compression - - -	- 320
3. Of the Improvement of Soils by Aeration or Fallowing - - -	- <i>ib.</i>
4. Alteration of the constituent Parts of Soils - - -	- 321
5. Changing the Condition of Lands, in respect to Water - - -	- 323
6. Changing the Condition of Lands, in respect to Atmospherical Influence - - -	- 325
7. Rotation of Crops - - -	- 326

CHAP. II.	
Of Manures - - -	- 327
I. Of Manures of Animal and Vegetable Origin - - -	- 328
1. The Theory of the Operation of Manures of Animal and Vegetable Origin - - -	- <i>ib.</i>
2. Of the different Species of Manures of Animal and Vegetable Origin - - -	- 329
3. Of the fermenting, preserving, and applying of Manures of Animal and Vegetable Origin - - -	- 334
II. Of Manures of Mineral Origin - - -	- 336
1. Theory of the Operation of Mineral Manures - - -	- <i>ib.</i>
2. Of the different Species of Mineral Manures - - -	- 337

CHAP. III.	
Of the Agency of Heat, Light, Electricity, and Water, in Vegetable Culture - - -	- 342
I. Of Heat and Light - - -	- <i>ib.</i>
II. Of Electricity - - -	- 346
III. Of Water - - -	- <i>ib.</i>

CHAP. IV.	
Of the Agency of the Atmosphere in Vegetation - - -	- 347
I. Of the Elements of the Atmosphere - - -	- <i>ib.</i>
II. Of the Means of prognosticating the Weather - - -	- 357
III. Of the Climate of Britain - - -	- 360

BOOK IV.

OF THE MECHANICAL AGENTS EMPLOYED IN AGRICULTURE.

CHAP. I.	Page
Of the Implements of Manual Labor used in Agriculture - - -	- 361
I. Tools used in Agriculture - - -	- <i>ib.</i>
II. Instruments - - -	- 364
1. Instruments of Labor - - -	- <i>ib.</i>
2. Instruments of Science - - -	- 365
III. Utensils used in Agriculture - - -	- 368
IV. Hand Machines used in Agriculture - - -	- <i>ib.</i>

CHAP. II.	
Of Agricultural Implements and Machines drawn by Beasts of Labor - - -	- 372
I. Of Tillage Implements and Machines - - -	- 373
1. Of Swing Ploughs, or such as arc constructed without Wheels - - -	- <i>ib.</i>
2. Wheel Ploughs - - -	- 377
3. Of the Tillage Implements, known as Scarifiers, Scafflers, Cultivators, and Grubbers - - -	- 381
4. Of Tillage Implements of the Hoe Kind - - -	- 383
II. Of Machines for Sowing and Planting - - -	- 386
III. Of Harrows - - -	- 391
IV. Of Rollers - - -	- 393
V. Of Machines for laying Land even, and other occasional or anomalous Tillage Machines - - -	- 395
VI. Of Machines for reaping and gathering the Crop - - -	- 396
1. Of Horse Rakes and Haymaking Machines - - -	- <i>ib.</i>
2. Reaping Machines - - -	- 397
VII. Machines of Deportation - - -	- 398
1. Carts - - -	- <i>ib.</i>
2. Waggon - - -	- 401
VIII. Machines for threshing and otherwise preparing Corn for Market - - -	- 402
IX. Mechanical and other fixed Apparatus, for the Preparation of Food for Cattle, and grinding Manure - - -	- 406

CHAP. III.	
Edifices in use in Agriculture - - -	- 408
I. Buildings for Live Stock - - -	- <i>ib.</i>
II. Buildings as Repositories, and for performing in-door Operations - - -	- 414
III. Of the Farmer's Dwelling-House - - -	- 417
IV. Of Cottages for Farm Servants - - -	- 419
V. Of the Stack-yard, Dung-yard, and other Enclosures immediately connected with Farm Buildings - - -	- 422
VI. Of the Union of the different Farm Buildings and Enclosures in a Farmery - - -	- 425

CHAP. IV.	
Of the Fences used in Agriculture - - -	- 430
I. Of the Situation or Emplacement of Fences - - -	- 431
II. Of the different Kinds of Fences - - -	- 432
1. Ditch or Drain Fences - - -	- <i>ib.</i>
2. Of Hedge Fences - - -	- 433
3. Of Compound Hedge Fences - - -	- 438
4. Paling Fences - - -	- 439
5. Wall Fences - - -	- 443

CHAP. V.	
Of Gates appropriate to Agriculture - - -	- 445

BOOK V.

OF THE OPERATIONS OF AGRICULTURE.

CHAP. I.	
Manual Labors and Operations - - -	- 450
I. Mechanical Operations common to all Arts of Manual Labor - - -	- <i>ib.</i>
II. Agricultural Labors of the Simplest Kind - - -	- 451
III. Agricultural Operations with Plants - - -	- 453
IV. Mixed Operations performed by Manual Labor - - -	- 460

CHAP. II.	
Agricultural Operations requiring the Aid of Laboring Cattle - - -	- 468

	Page		Page
I. Operations for the Care of Live Stock	- 468	2. Of taking the Levels of Surfaces	- 479
II. Labors with Cattle on the Soil	- 470	3. Of the Division and Laying out of Lands	480
III. Labors and Operations with the Crop	- 474	4. Of estimating Weight, Power, and Quantities	- 482
CHAP. III.			
Scientific Operations, and Operations of Order and general Management	- 477	5. Of estimating the Value of Agricultural Labor and Materials	- 483
I. Scientific Operations required of the Agriculturist	- <i>ib.</i>	6. Of the Professional Etiquette of Land Surveyors, Appraisers, and Valuers, in making up their Plans and Reports	- 487
- 1. Of Measuring relatively to Agriculture	- 478	II. Operations of Order and Management	- 491

## PART III.

## AGRICULTURE AS PRACTISED IN BRITAIN.

## BOOK I.

## OF THE VALUATION, PURCHASE, AND TRANSFER OF LANDED PROPERTY.

	Page
CHAP. I.	
Of the different Kinds and Tenures of landed Property in the British Isles	- 494
I. Of the Kinds of landed Property, and its different Tenures in England	- <i>ib.</i>
II. Of the Kinds and Tenures of landed Property in Scotland	- 495
III. Of the Kinds and Tenures of landed Property in Ireland	- 496
CHAP. II.	
Of the Valuation of landed Property	- <i>ib.</i>
CHAP. III.	
Of the Purchase or Transfer of landed Property	500

## BOOK II.

## OF THE LAYING OUT, OR GENERAL ARRANGEMENT OF LANDED ESTATES.

	Page
CHAP. I.	
Of consolidating Detached Property	- 502
CHAP. II.	
Of appropriating Commonable Lands	- 503
I. Of the Origin and different Kinds of Commonable Lands	- <i>ib.</i>
II. Of the general Principles of appropriating and dividing Commonable Lands	- 505
CHAP. III.	
Of the Choice of the Demesne or Site for the Proprietor's Residence	- 508
CHAP. IV.	
On the Formation of Roads	- 510
I. Of the different Kinds of Roads	- 511
II. Of the Line of Direction or laying out of Roads	- 512
III. Of the Form and Materials of Roads	- 516
1. Of the Formation of Roads, and of their Wear or Injury	- <i>ib.</i>
2. Of M'Adam's Theory and Practice of Road-making	- 518
3. Road-making as treated of and practised by various eminent Engineers and Surveyors	- 520
IV. Of paved Roads	- 536
V. Of Railroads	- 539
VI. Of the Preservation and Repair of Roads	- 542
CHAP. V.	
Of the Formation of Canals	- 550
I. Utility of Navigable Canals	- <i>ib.</i>
II. Of discovering the most eligible Rout for a Line of Canal	- 551
III. Of the Powers granted to Canal Companies by Government	- 553

IV. Of the Execution of the Works	- 554
-----------------------------------	-------

## CHAP. VI.

Of the Improvement of Estates by the Establishment of Mills, Manufactories, Villages, Markets, &c.	556
--	-----

## CHAP. VII.

Of Mines, Quarries, Pits, and Metalliferous Bodies	- 560
--	-------

## CHAP. VIII.

Of the Establishment of Fisheries	- 563
I. Of Marine Fisheries	- <i>ib.</i>
II. Of River, Lake, and other Inland Fisheries	565

## CHAP. IX.

Of Plantations and Woodlands	- 568
I. Of the Soils and Situations which may be most profitably employed in Timber Plantation	- 569
II. Of the Trees suitable for different Soils, Situations and Climates	- <i>ib.</i>
III. Of forming Plantations	- 571
IV. Of the Mixture of Trees in Plantations	- 578
V. Of the Culture of Plantations.	- 580
1. Of the Culture of the Soil among Trees	- <i>ib.</i>
2. Of the Filling up of Blanks or Failures in Plantations	- <i>ib.</i>
3. Of Pruning and Heading Down Trees in Plantations	- 581
4. Of Thinning Young Plantations	- 584
VI. Of the Improvement of Neglected Plantations	- 586
VII. Of the Treatment of Injured and Diseased Trees	- 587
VIII. Of the Products of Trees and their Preparation for Use or Sale.	- 589
IX. Of estimating the Value of Plantations and their Products, and of exposing them to Sale	- 595

## CHAP. X.

Of the Formation and Management of Orchards	596
I. Of the Soils and Situations most suitable for Orchards	- 597
II. Of the Sorts of Trees and Manner of Planting	- <i>ib.</i>
III. Of the Cultivation of Farm Orchards	- 601
IV. Of the Gathering and Keeping of Orchard Fruits	- 602
V. Of the Manufacture of Cider	- 603
VI. Of the Machinery and Utensils necessary for Cider making	- 606

## CHAP. XI.

Of the laying out of Farm and other Culturable Lands	- 608
I. Of the Extent or Size of Farm and Cottage Lands	- <i>ib.</i>
II. Of laying out Farms and Farmeries	- 611
1. Of the Situation and Arrangement of the Farmery	- <i>ib.</i>
2. Of laying out Cottages	- 619
3. Of laying out the Farm Lands	- 621



BOOK III.

OF IMPROVING THE CULTURABLE LANDS OF AN ESTATE.

CHAP. I.	Page
Of Draining Watery Lands	625
I. Of the Natural Causes of Wetness in Lands and the general Theory of Draining	ib.
II. Of the Methods of Draining Boggy Land	628
III. Of the Methods of Draining Mixed Soils	634
IV. Of the Methods of Draining Retentive Soils	635
V. Methods of Draining Mines, Quarries, and Pits	637
VI. Of the Formation of Drains, and the Materials used in Filling them	638
VII. Of the Implements peculiar to Draining	643

CHAP. II.

Of Embanking and otherwise protecting Lands from the Overflowing or Encroachment of Rivers or the Sea	645
I. Of Embanking Lands from Rivers or the Sea	ib.
1. General Principles of designing Embankments	ib.
2. Of the different Descriptions of Banks in general Use for excluding Waters	647
II. Of guarding the Banks, and otherwise improving the Course of Rivers and Streams	650
1. On guarding River Banks	651
2. Of Changing the Course of Rivers	653

CHAP. III.

Of Irrigation, or the Improvement of Culturable Lands and Farmeries by the Means of Water	654
I. Of Irrigation or the Preparation of the Surface of Lands for the profitable Application of Water	ib.
1. Of the Soils and Situations suitable for the Purposes of Watering Lands	655
2. Of the Implements made Use of in Watering Lands; and of the Terms of Art peculiar to Works of that Kind	656
3. Of the Preparation of Surfaces for Irrigation	660
II. Of Warping, or the Improvement of Land by Muddy Water	665
1. Of the Irrigation of Arable Lands and of Subterraneous Irrigation	667
III. Of the Artificial Means of procuring Water for the Use of Live Stock	ib.

CHAP. IV.

Of the Improvement of Lands lying Waste, so as to fit them for Farm Culture	673
I. Of mountainous and hilly Grounds and their Improvement	ib.
II. Of rocky or stoney Surfaces	ib.
III. Of improving woody Wastes or Wealds	675
IV. Of Moors and their Improvements	676
V. Of Peat Mosses, Bogs, and Morasses, and their Improvements	677
VI. Of Marshes and their Improvement	679
VII. Of Downs and other Shore Lands.	680

CHAP. V.

Of the Improvement of Lands already in a State of Culture	681
I. Of the general Principles and Modes of Procedure in improving Estates already more or less improved	ib.
II. Of the Improvement of Farmeries and Farm Lands	ib.

CHAP. VI.

Of the Execution of Improvements	688
I. Of the different Modes of procuring the Execution of Improvements on Estates	ib.
II. General Cautions on the Subject of executing Improvements	690

BOOK IV.

OF THE MANAGEMENT OF LANDED PROPERTY.

CHAP. I.	Page
Of the Superintendants, or Executive Establishment of an Estate	692
I. Of the Steward or Manager of an Estate, and his Assistants	ib.
II. Of the Land Steward's Place of Business, and what belongs to it	694

CHAP. II.

Of the Duties of Managers of Estates	695
I. Of the general Principles of Business considered relatively to Land-Stewardship	ib.
II. Of the Management of Tenants	696
1. Of the proper Treatment of Tenants	ib.
2. On the Business of letting Farms	697
3. Of the different Species of Tenancy	ib.
4. Of the Rent and Covenants of a Lease	700
5. Of receiving Rents	702
III. Of Keeping and Auditing Accounts	703

BOOK V.

OF THE SELECTION, HIRING, AND STOCKING OF FARMS.

CHAP. I.

Of the Circumstances of a Farm necessary to be considered by a proposed Tenant	704
I. Of Climate in respect to Farming Lands	705
II. Of Soil in respect to Farming Lands	708
III. Of Subsoil relatively to the Choice of a Farm	710
IV. Of the Elevation of Lands relatively to Farming	711
V. Character of Surface in regard to Farming Lands	712
VI. Of Aspect in respect to Farming Lands	ib.
VII. Of the Situation of Farm Lands in regard to Markets	ib.
VIII. Of the Extent of Land suitable for a Farm	713
IX. Of the Tenure on which Lands are held for Farming	714
X. Of Rent	ib.
XI. Of Taxes and other Burdens which affect the Farmer	716
XII. Of other Particulars requiring a Farmer's Attention, with a view to renting of Land	717

CHAP. II.

Considerations respecting himself, which a Farmer ought to keep in view in selecting and hiring a Farm	718
I. Of the personal Character and Expectations of a professional Farmer	ib.
II. Of the Capital required by the Farmer	719

CHAP. III.

On the Choice of Stock for a Farm	720
I. Of the Choice of Live Stock	ib.
1. Live Stock for the Purposes of Labor	721
2. Of the Choice of Live Stock for the Purposes of breeding or feeding	722
II. Of the Choice of Agricultural Implements, Seeds, and Plants	725
III. Of the Choice of Servants	726

CHAP. IV.

Of the general Management of a Farm	728
I. Of keeping Accounts	ib.
II. Management of Servants	732
III. Of the Arrangement of Farm Labor	734
IV. Of domestic Management and personal Expenses	736

BOOK VI.

OF THE CULTURE OF FARM LANDS.

CHAP. I.

Of the general Processes common to Farm Lands	ib.
---	-----

	Page		Page
I. Of the Rotations of Crops suitable to different Descriptions of Soils	737	8. Of various Plants which have been proposed as Substitutes for the Thread, and dyeing Plants grown in Britain	857
II. Of the Working of Fallows	740	II. Plants cultivated for the Brewery and Distillery	868
III. Of the general Management of Manures	742	1. The Hop	ib.
1. On the Management of Farm-yard Dung	ib.	2. Of the Culture of the Coriander and Caraway	866
2. Of Lime and its Management as a Manure	744	3. Of Plants which may be substituted for Brewery and Distillery Plants	ib.
IV. Of Composts of Earth, Lime, and Dung	745	III. Of Oil Plants	867
CHAP. II.			
Of the Culture of the Cereal Grasses	746	IV. Plants used in Domestic Economy	869
I. Wheat	ib.	1. Mustard	870
II. Rye	756	2. The Canary Grass	ib.
III. Barley	ib.	3. Buck-Wheat	871
IV. The Oat	760	4. Of other Plants used in Domestic Economy; which are or may be cultivated the Fields	872
V. Cereal Grasses cultivated in Europe, some of which might be tried in Britain	763	V. Of Plants which are or may be grown in the Fields for Medicinal Purposes	874
CHAP. III.			
Of the Culture of Leguminous Field Plants	765	CHAP. IX.	
I. The Pea	ib.	Of Marine Plants used in Agriculture	876
II. The Bean	769	CHAP. X.	
III. The Tare	773	Of Weeds or Plants which are injurious to those cultivated in Agriculture	877
IV. Of other Leguminous Grains which might be cultivated in British Farming	775	BOOK VII.	
CHAP. IV.			
Of Plants cultivated for their Roots or Leaves	776	THE ECONOMY OF LIVE STOCK AND THE DAIRY.	
I. The Potatoe	777	CHAP. I.	
II. The Turnip	786	Of the Horse	880
III. The Carrot	793	I. Of the Varieties of the Horse	ib.
IV. The Parsnep	797	II. Organology or exterior Anatomy of the Horse	885
V. The Field-Beet	798	III. The Anatomy or Osseous Structure of the Horse	892
VI. The Cabbage Tribe	799	1. Anatomy of the Head	ib.
VII. Of some other Plants which might be cultivated in the Fields for their Roots or Leaves	800	2. The Anatomy of the Trunk	894
CHAP. V.			
Of the Culture of Herbage Plants	ib.	3. The Anatomy of the Extremities	895
I. The Clover Family	801	IV. Of the Physiology or Functions of the Horse	896
II. Lucern	806	1. General Functions of the Bony Skeleton	ib.
III. Saintfoin	809	2. The Blood Vessels of the Horse	898
IV. Of various Plants which are or may be cultivated as Herbage and for Hay	812	3. The Absorbents of the Horse	ib.
CHAP. VI.			
Of the cultivated Grasses	817	4. Nerves and Glands of the Horse	899
I. Of the tall growing or Hay Grasses	ib.	5. Integuments of the Horse's Body	ib.
1. Of tall or Hay Grasses of temporary Duration	818	6. The Head generally	900
2. Of tall or Hay Grasses of permanent Duration	820	7. The Ear	ib.
II. Grasses chiefly adapted for Pasturage	824	8. The Eye and its Appendages	ib.
III. General View of the Produce, Uses, Character, and Value of the principal British Grasses, according to the result of John Duke of Bedford's Experiments at Woburn	826	9. The Nose and Sense of Smelling	902
CHAP. VII.			
Of the Management of Lands permanently under Grass	832	10. The Cavity of the Mouth	ib.
I. Perennial Grass Lands fit for mowing, or Meadow Lands	ib.	11. The Neck	903
II. Of permanent Pastures	833	12. The Thorax or Chest	904
1. Of rich or feeding pastures	ib.	13. The Abdomen	ib.
2. Of hilly and mountainous Pastures	841	14. The Organs of Generation	907
III. Of the Improvement of Grass Lands, by a temporary Conversion to Tillage	842	15. The Foot	ib.
1. Of Grass Lands that ought not to be broken up by the Plough	843	V. Of the Diseases of the Horse	908
2. Of the Advantages and Disadvantages of breaking up Grass Lands	844	1. General Remarks on the healthy and diseased State of the Horse	ib.
3. Of breaking up Grass Lands, and afterwards restoring them to Grass	ib.	2. Inflammatory Diseases of the Horse	909
CHAP. VIII.			
Of Plants cultivated on a limited Scale for various Arts and Manufactures	846	3. Diseases of the Head	911
I. Of Plants grown chiefly for the Clothing Arts	ib.	4. Diseases of the Neck	912
1. The Flax	ib.	5. The Chest	ib.
2. Hemp	851	6. Diseases of the Skin	916
3. The Fuller's Thistle, or Teazle	852	7. Glanders and Farcy	ib.
4. Madder	854	8. Diseases of the Extremities	917
5. Woad	855	9. Diseases of the Feet	919
6. Weld or Dyer's Weed	856	VI. Veterinary Operations	920
7. The Bastard Saffron	857	1. Treatment of Wounds	ib.
		2. Balls and Drinks	921
		3. Fomentations and Poultices	ib.
		4. Setons and Rowels	ib.
		5. Blistering and Firing	922
		6. Clystering and Physicking	ib.
		7. Castration, Nicking, Docking, &c.	ib.
		8. Bleeding	923
		VII. The Veterinary Pharmacopeia	ib.
		VIII. The Shoeing of Horses	926
		IX. Criteria of the Qualities of Horses for various purposes	929
		X. Of Breeding Horses	932
		XI. Of Rearing Horses	935
		XII. Of Training Horses	937
		XIII. Of the Art of Horsemanship	940

	Page
XIV. Of the Feeding of Horses	- 941
XV. Of the Stabling and Grooming of Horses	943
XVI. Of the Management and Working of Horses	- 945
1. Management and Working of Race Horses	<i>ib.</i>
2. Of the Management and Working of the Hunter	- 946
3. Of the Working and Management of Riding Horses	- 947
4. Of Horses in Carriages and Coaches	- 948
5. Working of Cart, Waggon, and Farm Horses	- <i>ib.</i>
CHAP. II.	
The Ass	- 950
CHAP. III.	
Of the Mule and Hinny, Hybrids of the Horse and Ass	- 952
CHAP. IV.	
Of Neat or Horned Cattle	- 953
I. Of the Ox	- <i>ib.</i>
1. Of the Varieties and Breeds of the Bull	- <i>ib.</i>
2. Criteria of Cattle for various Objects and Purposes	- 959
3. Of the Breeding of Horned Cattle	- 961
4. Of rearing Horned Cattle	- 962
5. Of fattening Calves by Suckling	- 963
6. Of fattening Horned Cattle	- 965
7. Of the Management of Cows kept for the Dairy	- 966
8. Of Working Horned Cattle	- 970
9. Of the Anatomy and Physiology of the Bull and Cow	- 972
10. Of the Diseases of Horned Cattle	- 973
II. Of the Buffalo	- 977
CHAP. V.	
Of the Dairy and its Management	- <i>ib.</i>
I. Of the Chemical Principles of Milk, and the Properties of the Milk of different Animals	- 978
II. Of the Dairy House, its Furniture, and Utensils	- 979
III. Of Milking, and the general Management of Milk	- 983
IV. Of Making and Curing Butter	- 984
V. Of the Process of Cheese-making	- 985
VI. Catalogue of the different Sorts of Cheeses and other Preparations made from Milk	989
CHAP. VI.	
The Sheep	- 992
I. Of the Varieties of Sheep	- <i>ib.</i>
II. Criteria of Properties in Sheep	- 996
III. Of Breeding Sheep	- 997
IV. Of the rearing and general Management of Sheep	- 1000
1. Of the rearing and Management of Sheep on rich Grass and arable Lands	- 1001
2. Of the rearing and general Management of Sheep on Hilly and Mountainous	

	Page
Districts, or what is generally termed Store Sheep Husbandry	- 1003
V. Of the Folding of Sheep	- 1007
VI. Of Fattening Sheep and Lambs	- 1008
VII. On the probable Improvement which may be derived from Crosses of the Merino Breed of Sheep	- 1010
VIII. Of the Anatomy and Physiology of Sheep	- 1012
IX. The Diseases of Sheep	- <i>ib.</i>
CHAP. VII.	
The Swine	- 1014
I. Of the Varieties of the common Hog	- 1016
II. Of Breeding and Rearing of Swine	- 1018
III. Of Fattening Swine	- 1019
IV. Of curing Pork and Bacon	- 1020
V. Of the Diseases of Swine	- <i>ib.</i>

CHAP. VIII.	
Of the Goat, Rabbit, Hare, Dormouse, Deer, and various other Animals, that are or may be subjected to British Agriculture	- 1021

CHAP. IX.	
Of Animals of the Bird kind employed in Agriculture	- 1034
I. Of Poultry Houses, and their Furniture and Utensils	- <i>ib.</i>
II. Of Gallinaceous Fowls, their Kinds, Breeding, Rearing, and Management	- 1035
III. Anserine, or Aquatic Fowls	- 1043
IV. Diseases of Poultry	- 1048
V. Of Birds of Luxury, which are or may be cultivated by Farmers	- <i>ib.</i>

CHAP. X.	
Of Fish and Amphibious Animals subjected to Cultivation	- 1055

CHAP. XI.	
Of Insects and Worms which are or may be subjected to Culture	- 1058

CHAP. XII.	
Of Animals Noxious to Agriculture	- 1063
I. Of Noxious Mammalia	- <i>ib.</i>
II. Birds injurious to Agriculture	- 1065
III. Insects injurious to Agriculture	- 1066
1. Of the Physiology of the Insect Tribes	- <i>ib.</i>
2. Of Coleopterous Insects	- 1068
3. Of Hemipterous Insects	- 1069
4. Of Lepidopterous Insects	- 1071
5. Of Neuropterous, or Nerve-winged Insects	- 1072
6. Of Hymenopterous Insects	- 1073
7. Of Dipterous Insects	- <i>ib.</i>
8. Of Apterous Insects	- 1075
9. Operations for subduing Insects	- <i>ib.</i>
IV. Of the Worm Tribes injurious in Agriculture	- <i>ib.</i>

## PART IV.

### STATISTICS OF BRITISH AGRICULTURE.

#### BOOK I.

##### OF THE PRESENT STATE OF AGRICULTURE IN THE BRITISH ISLES.

	Page
Of the different Descriptions of Men engaged in the Practice or Pursuit of Agriculture	- 1076
I. Of Operators or serving Agriculturists	- 1077
II. Commercial Agriculturists	- 1078
III. Agricultural Counsellors, Artists, or Professors	- 1079
IV. Patrons of Agriculture	- 1080

	Page
Of the different Kinds of Farms in Britain relatively to the different Classes of Society who are the Occupiers	- 1081

CHAP. III.	
Topographical Survey of the British Isles in respect to Agriculture	- 1082
I. Agricultural Survey of England	- <i>ib.</i>
II. Agricultural Survey of Wales	- 1130
III. Agricultural Survey of Scotland	- 1134
IV. Agricultural Survey of Ireland	- 1154

CHAP. IV.		Page
Of the Literature and Bibliography of Agriculture	-	1162
I. The Bibliography of British Agriculture	-	<i>ib.</i>
II. Bibliography of Agriculture in Foreign Countries	-	1171
1. Bibliography of French Agriculture	-	<i>ib.</i>
2. Bibliography of German Agriculture	-	1175
3. Bibliography of Italian Agriculture	-	1177
4. Of the Bibliography of the Agriculture of the other Countries of Europe	-	1178
5. Agricultural Bibliography of North America	-	1179

CHAP. V.	
Of the Professional Police and Public Laws relative to Agriculturists and Agriculture	- <i>ib.</i>

KALENDARIAL INDEX	-	-	-
GENERAL INDEX	-	-	-

## BOOK II.

OF THE FUTURE PROGRESS OF AGRICULTURE  
IN BRITAIN.

CHAP. I.		Page
Of the Improvement of Agriculture by refining the Taste of the Purchasers of its Products, and increasing the Knowledge of Agricultural Patrons	-	1181
CHAP. II.		
On the Improvement of Agriculture by the better Education of those who are engaged in it as a Profession	-	1182
I. On the Degree of Knowledge which may be attained by Practical Men, and on the general Powers of the human Mind as to Attainments	-	<i>ib.</i>
II. Of the Professional Education of Agriculturists	-	1184
III. Of the Conduct and Economy of an Agriculturist's Life	-	1186

# ENCYCLOPÆDIA

OF

## AGRICULTURE.

---

**T**HE first want of man is food, and his first resource for it the ground. Whether herbs or fruits were resorted to, must have depended on their relative abundance in the country where man found himself; but the latter would probably be preferred, till the use of fire was discovered in the preparation of the former. The first care and labor of man would thus be bestowed on fruit-trees, and hence gardening may be said to be the art of earliest invention. But man is also a carnivorous animal, and this propensity of his nature would soon induce him to attempt domesticating such beasts of the earth as he found most useful in affording milk, clothing, or food; or in performing labor. Hence the origin of pasturage, and the management of live stock. The invention of tillage would be coeval with the discovery of the use of the cereal grasses, and may be considered as the last grand step in the invention of husbandry, and the most important, as leading to the establishment of property in territorial surface.

In the earlier stages of civilisation, these branches of economy, in common with all the arts of life, would be practised by every family for itself; but the advantages of separating occupations would soon present themselves, and the result of this principle in regard to rural culture and management;— the *res rustica* of the Romans and husbandry of old English authors,— is, that all their operations are now classed under the two designations of agriculture and gardening.

*Agriculture*, the art to which we here confine ourselves, as compared to gardening, is the culture and management of certain plants and animals for the food and service of man; but relative to the present improved state of the art, it may be defined, the cultivation and management of territorial surface on an extended scale, by manual and animal labor, for the production of objects and materials used for the food and service of man, and for various important purposes, in arts, manufactures, and civilised life.

The importance of agriculture is obvious, not only by its affording the direct supply of our greatest wants, but as the parent of manufactures and commerce. Without agriculture there can be neither civilisation nor population. Hence it is not only the most universal of arts, but that which requires the greatest number of operators: the main body of the population in every country is employed in the pursuit of agriculture; and the most powerful individuals in almost all nations, derive their wealth and consequence from their property in land.

In the earliest ages of mankind, before tillage was invented, the surface of the earth would be common to all the inhabitants, and every family would pasture their flock, and pitch their tent, or erect their hut, where they thought fit. But when tillage came in use, it became necessary to assign to each family a portion of territory, and of this portion that family became the proprietor, cultivator, and the consumer of the products. Hence the invention of property in land, and progressively of purchased cultivators,

or slaves; of hired cultivators, or laborers; of commercial agriculturists, or farmers; and of the various laws and customs in regard to the proprietorship and occupation of landed property.

The practice of agriculture, however rude in early times, or in countries still comparatively uncivilised, assumes a very different character among the most advanced nations. Not to mention the peculiarities of implements, machines, and domestic animals, and the different kinds of culture and management requisite for the different countries and climates of the world, the local variations requisite even in Britain, are so considerable that an agriculturist whose experience and observation had been confined to one district, may be comparatively unfit to exercise his profession in another. The sheep farming of the North Highlands, the dairy farming of Gloucestershire, the hop culture of Kent, the woodlands of Buckinghamshire, and the hay management of Middlesex, have given rise to commercial agriculturists of very distinct varieties from the common corn farmer. The previous preparation of land for culture, by enclosure, drainage, embanking, road-making, &c. demands considerable science; and has given rise to artist agriculturists, known as land-surveyors, and land-engineers. The relative changes as to rent and occupancy which take place between land-owners and farmers, and the valuation and transfer of landed property among monied men, have produced land-valuators and land-agents; from the direction of extensive estates, and the management of small concerns and farms, have originated the serving agriculturists, known as land-stewards and bailiffs; and the operators are shepherds, herdsmen, ploughmen, carters, spademen, and hands of all work.

The practice of agriculture, from having been chiefly confined to men of humble station, who pursued it as a matter of business or profit, has of late years been engaged in by men of rank, and other opulent or amateur practitioners, as matter of taste and recreation. The contrast between the simple and healthy pursuits of the country, and such as require intense application, and confine men chiefly to towns and cities, gives them a peculiar charm to the industrious and active citizen, while the idle and the opulent find relief in it from the *ennui* of inaction or a frivolous waste of time. Some magnificent displays of the art have thus been made by great landed proprietors on their demesne or home farms; and very neat and tasteful specimens of culture, by retired citizens and other possessors of villas, farms, and *fermes ornées*. These circumstances may be said to have raised the pursuit of agriculture to a comparatively dignified state to that in which it was formerly held; while the political advantages which are enjoyed by all classes in a free and commercial country, have improved the circumstances of agriculturists of every grade, and tended to raise them in the scale of society.

The recent discoveries in chemistry and physiology have led to the most important improvements in the culture of plants, and the breeding and rearing of animals; agriculture is in consequence no longer an art of labor, but of science; hence the advantage of scientific knowledge to agriculturists, and the susceptibility of the art of progressive advancement. "Agriculture," Marshal observes, "is a subject which, viewed in all its branches and to their fullest extent, is not only the most important and the most difficult in rural economies, but in the circle of human arts and sciences."

For the purpose of agricultural improvement, societies have been established in every country of Europe, and in almost every county of Britain. Most of these, as well as several eminent individuals, have stimulated cultivators and breeders to exertion, by the offer of premiums, and other honorary rewards. Professorships of rural economy have also been instituted in some colleges; and other independent geological institutions have been established for public instruction, especially on the continent: — to which we may add, the publication of numerous books on the subject of agriculture and territorial improvement.

Such is the origin, the extent, the importance, and the interest of the subject of agriculture; from which it cannot be surprising that a varied and voluminous mass of knowledge has been accumulated on the subject, and is consequently more or less necessary for every one who would practise the art with success himself, or understand when it is well practised for him by others. To combine as far as practicable the whole of this knowledge, and arrange it in a systematic form, adapted both for study and reference, is the object of the present work. The sources from which we have selected, are the modern British authors of decided reputation and merit; sometimes we have resorted to ancient and to Continental authors, and occasionally, though rarely, to our own observation and experience: — *observation* chiefly in Britain, but partly also on the Continent; and *experience* in Scotland, under the paternal roof, during our early years, — during some years' occupancy of two extensive farms in England, — and in the engineering and surveying departments during our practice for twenty years as a landscape-gardener.

With this purpose in view, agriculture is here considered, in

PART	Book
I. As to its origin, progress, and present state,	<ul style="list-style-type: none"> <li>1. Among ancient and modern nations.</li> <li>2. Under different geographical, physical, and political circumstances.</li> </ul>
II. As a science founded on	<ul style="list-style-type: none"> <li>1. The study of the vegetable kingdom.</li> <li>2. The study of the animal kingdom.</li> <li>3. The study of the mineral kingdom and the atmosphere.</li> <li>4. The study of the mechanical agents employed in agriculture.</li> <li>5. The study of the operations of agriculture.</li> </ul>
III. As an art comprehending	<ul style="list-style-type: none"> <li>1. The valuation, purchase, and transfer of landed property.</li> <li>2. The laying out, or general arrangement, of landed property.</li> <li>3. The improvement of culturable lands.</li> <li>4. The management of landed estates.</li> <li>5. The selection, hiring, and stocking of farms.</li> <li>6. The culture of farm lands.</li> <li>7. The economy of live stock, and the dairy.</li> </ul>
IV. Statistically in Britain,	<ul style="list-style-type: none"> <li>1. As to its present state.</li> <li>2. As to its future progress.</li> </ul>

A Kalendarial Index to those parts of the work which treat of culture and management, points out the operations as they are to be performed in the order of time and of the season : and

A General Index explains the technical terms of agriculture, the abbreviations here made use of, and presents an analysis of the whole work in alphabetical, as the Table of Contents does in systematic, order.

## PART I.

### AGRICULTURE CONSIDERED AS TO ITS ORIGIN, PROGRESS, AND PRESENT STATE, AMONG DIFFERENT NATIONS, GOVERNMENTS, AND CLIMATES.

1. *The history of Agriculture* may be considered chronologically, or in connection with that of the different nations who have successively flourished in the different parts of the world ; politically, as influenced by the different forms of government which have prevailed ; geographically, as affected by different climates ; and physically, as influenced by the characters of the earth's surface. The first kind of history is useful, by displaying the relative situation of different countries as to agriculture ; instructive, as enabling us to contrast our present situation with that of other nations and former times ; and curious, as discovering the route by which agriculture has passed from primitive ages and countries to our own. The political and geographical history of the art derives its value from pointing out causes, favorable and unfavorable to improvement ; and countries and climates favorable or unfavorable to particular kinds of cultivation and management.

## BOOK I.

### HISTORY OF AGRICULTURE AMONG ANCIENT AND MODERN NATIONS.

2. *Traditional history* traces man back to the time of the deluge. After that catastrophe, of which the greater part of the earth's surface bears evidence, man seems to have recovered himself (in our hemisphere at least) in the central parts of Asia, and to have first attained to eminence in arts and government, on the alluvial plains of the Nile. Egypt colonised Greece, Carthage, and some other places on the Mediterranean sea ; and thus the Greeks received their arts from the Egyptians, afterwards the Romans from the Greeks, and finally the rest of Europe from the Romans. Such is the route by which agriculture is traced to our part of the world ; how it may have reached the eastern countries of India and China, is less certain ; though from the great antiquity of their inhabitants and governments, it appears highly probable that arts and civilisation were either coeval there, or, if not, that they travelled to the east fully more rapidly than they did to the west.

3. *The early history of man in America* rests on very indistinct traditions : there arts and civilisation do not seem of equal antiquity as in Asia ; in North America they are

of very recent introduction ; but of the agriculture of either division of that continent, and of India and China, we shall attempt little more than some sketches of the modern history, and its present state.

4. *The history of agriculture among the nations of what may be called classic antiquity is involved in impenetrable obscurity.* Very few facts are recorded on the subject previously to the time of the Romans. That enterprising people considerably improved the art, and extended its practice with their conquests. After the fall of their empire, it declined throughout Europe ; and during the dark ages was chiefly preserved on the estates of the church. With the general revival of arts and letters, which took place during the sixteenth century, agriculture also revived ; first in Italy, and then in France and Germany ; but it flourished most in Switzerland and Holland ; and finally, in recent times, has attained its highest degree of perfection in Britain. The modern agriculture of America is copied from that of Europe ; and the same may be said of the agriculture of European colonies established in different parts of the world. The agriculture of China, and the native agriculture of India, seem to have undergone no change for many ages. — Such is the outline which we now proceed to fill up by details, and we shall adopt the usual division of time, into the ages of antiquity, the middle ages, and the modern times.

#### CHAP. I.

*Of the History of Agriculture in the Ages of Antiquity ; or from the Deluge to the Establishment of the Roman Empire in the century preceding the vulgar æra.*

5. *The world as known to the ancients consisted of not more than half of Asia, and of a small part of Africa and Europe.* During the inundation of the deluge, a remnant of man, and of other animals, is related to have been saved on the top of the high mountain of Ararat, near the Caspian sea, (*fig. 1.*) and when the waters sub-



sided, to have descended and multiplied in the plains of Assyria. As they increased in numbers they are related to have separated ; and after an unknown length of time to have formed several different nations and governments. Of these the principal are those of the Assyrian empire, known as Babylonians, Assyrians, Medes, and Persians, in Asia ; the Jews and the Egyptians, chiefly in Africa ; and the Grecians, chiefly in Europe. Least is known of the nations which composed the Assyrian empire ; of the Jews more is known of their gardening and domestic economy, than of their field culture ; the Egyptians may be considered the parent nation of arts and civilisation, and are supposed to have excelled in agriculture ; and something is known of that art among the Greeks.

6. *The authors whose writings relate to the period under consideration are few, and the relations of some of them very contradictory.* The earliest is Moses, who flourished B. C. 1600 ; Herodotus and Diodorus Siculus, who wrote more particularly on the history and geography of Egypt, lived, the former in the fifth, and the latter in the sixth century, B. C. ; and Hesiod, the ancient Greek writer on husbandry, in the tenth century preceding our æra.

7. *Estimating the value of the writers of antiquity on these principles, they may be considered as reaching back to a period 1600 years before our æra, or nearly 3500 years from the present time ; and it is truly remarkable, that in the Eastern countries, at that period, the state of agriculture and other arts, and even of machinery, does not appear to have been materially different to what they are in the same countries at the present day.*



Property in land was recognised, the same grains cultivated, and the same domestic animals reared or employed; some led a wandering life and dwelt in tents like the Arabs; and others dwelt in towns or cities, and pursued agriculture and commerce like the fixed nations. It is reasonable indeed, and consistent with received opinions, that this should be the case; for admitting the human race to have been nearly exterminated at the deluge, those who survived that catastrophe would possess the more useful arts, and general habits of life of the antediluvian world. Noah accordingly is styled a husbandman, and is said to have cultivated the vine and made wine. In little more than three centuries afterwards, Abraham is stated to have had extensive flocks and herds, slaves of both sexes, silver and gold, and to have purchased a family sepulchre with a portion of territory around it. Isaac his son, during his residence in Palestine, is said to have sown and reaped a hundred fold. Corn seems to have been grown in abundance in Egypt; for Abraham, and afterwards Jacob, had recourse to that country during times of famine. Irrigation was also extensively practised there, for it is said (*Gen. xiii. 10.*) that the plain of Jordan was watered everywhere, even as the garden of the Lord, the land of Egypt. Such is the amount of agricultural information contained in the writings of Moses, from which the general conclusion is, that agriculture, in the East, has been practised in all or most of its branches from time immemorial. The traditions of other countries, however, as recorded by various writers, ascribe its invention to certain fabulous personages; as the Egyptians to Osiris; the Greeks to Ceres and Triptolemus; the Latins to Janus; the Chinese to Chin-hong, successor of Fo-hi.

### SECT. I. *Of the Agriculture of Egypt.*

8. *The origin of agriculture* has been sought by modern philosophers in natural circumstances. Man in his rudest state, they consider, would first live on fruits or roots, afterwards by hunting or fishing, next by the pasturage of animals, and lastly, to all of these he would add the raising of corn. Tillage, or the culture of the soil for this purpose, is supposed to have been first practised in imitation of the effects produced by the sand and mud left by the inundations of rivers. These take place more or less in every country, and their effects on the herbage which spontaneously spring up among the deposited sand and mud must at a very early period have excited the attention of the countryman. This hypothesis seems supported by the traditions and natural circumstances of Egypt, a country overflowed by a river, civilised from time immemorial, and so abundant in corn as to be called the granary of the adjoining states. Sir Isaac Newton and Stillingfleet accordingly, considered that corn was first cultivated on the banks of the Nile. Sir Isaac fixes on Lower Egypt; but as Herodotus and other ancient Greek writers assert that that country was once a marsh, and as Major Rennel in his work on the geography of Herodotus is of the same opinion, Stillingfleet (*Works*, vol. ii. 524.) considers it more probable that the cultivation of land was invented in Upper Egypt, and proceeded downwards according to the course of the Nile.

9. *The situation and natural phenomena of Upper Egypt*, Stillingfleet considers, rendered it fitter for the invention of cultivation than the low country; "for while Lower Egypt was a marsh, formed by the depositions of the Nile, the principal part of Upper Egypt was a valley a few leagues broad, bounded by mountains, and on both sides declining to the river. Hence it was overflowed only for a certain time and season; the waters rapidly declined, and the ground, enriched by the mud, was soon dry, and in a state fit to receive seed. The process of cultivation in this country was also most obvious and natural; for the ground being every year covered with mud brought by the Nile, and plants springing up spontaneously after its recess, must have given the hint, that nothing more was necessary than to scatter the seeds, and they would vegetate. Secondly, the ground was prepared by nature for receiving the seed, and required only stirring sufficient to cover it. From this phenomenon the surrounding nations learned two things: first, that the ground before sowing should be prepared, and cleared from plants; and secondly, that the mixture of rich mould and sand would produce fertility. What is here stated may appear without foundation as to Upper Egypt; because at present, in the vicinity of Thebes, water is raised by art. But this objection is obviated by the testimony of Dr. Pococke, who is of opinion that formerly Upper Egypt was overflowed, in the same manner as Lower Egypt was afterwards, and is to this day." (*Stillingfleet's Life and Works*, &c. ii. 524.)

10. *The invention of agricultural implements*, must have been coeval with the invention of aration; and accordingly they are supposed to have originated in Egypt. Antiquarians are agreed, that the primeval implement used in cultivating the soil, must have been of the pick kind. (*fig. 2.*) A medal of the greatest antiquity, dug up at Syracuse, contained an impression of such an instrument (*Encyc. of Gard. fig. 77.*); and its pro-



gress till it became a plough has been recognised in a cameo, published by Menestrier, on which a pick-like plough is drawn by two serpents (*fig. 3. a*): it may be also seen on a medal from the village of Enna, in Sicily, published by Combe (*b*); in a figure given by Spon, as found on an antique tomb (*c*); in an Etruscan plough, copied from a fragment in the Roman college at Rome, by Lasteyrie (*d*); and as we still see in the instrument depicted by Niebuhr, as used for ploughing in Egypt and Arabia at the present day. (*e*) What seems to confirm these conjectures is, that the image of Osiris is sculptured with a similar plough in each hand (*fig. 4. a b c d*), and with a harrow (*e*) suspended by a cord (*f*) over the left shoulder. This plough there can be little doubt was used in war as well

as in agriculture, and seems to have been of that kind with which the Israelites fought against their enemies the Philistines (1 *Sam.* xiii. 19. 23.); it is thought by some to be the archetype of the letter alpha (the hieralpha of Kircher): and by others the sounds necessary to conduct the processes of culture are thought to have founded the origin of language. Thus it is that agriculture is considered by some antiquarians, as not only the parent of all other arts, but also of language and literature.

11. Whether the culture of corn was invented in Egypt or not, all testimonies concur that cultivation was carried to a higher degree of perfection there than in any other country of antiquity. The canals and banks which still remain in Lower Egypt, and especially in the Delta, are evidences of the extent to which embanking, irrigation, and drainage have been carried. These works are said to have been greatly increased by Sesostris, in the 17th or 18th century B. C. Many of the canals and drains have been long obliterated; but there are still reckoned eighty canals, like rivers, all excavated by manual labor, several of which are twenty, thirty, and forty leagues in length. These receive the inundations of the Nile, and circulate the waters through the country, which before was wholly overflowed by them. The large lakes of Mæris, Behire, and Mareotis, formed vast reservoirs for containing the superfluous waters, from which they were conducted by the canals over the adjacent plains. Upon the elevated ridges, and even on the sides of the hills which form the boundary to the flat alluvial grounds, the water was raised by wheels turned by oxen; and by a succession of wheels, and gradations of aqueducts, it is said some hills, and even mountains, were watered to their summits. All the towns at some distance from the Nile were surrounded with reservoirs for the supply of the inhabitants, and for watering the gardens. For this last purpose the water was raised in a very simple manner by a man walking on a plank with raised edges, or on a bamboo or other tube. This is the machine alluded to by Moses, when he speaks of sowing the seed and watering it "with the foot." (*Deut.* xi. 10.) They also raised it by swinging it up in baskets (*fig. 5.*); a mode which, like the others, remains in use at the present day. The water is lifted in a basket lined with leather. "Two men, holding the basket between them, by a cord in each end fastened to the edge of it, lower it into the Nile, and then swing it between

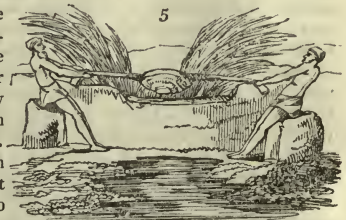
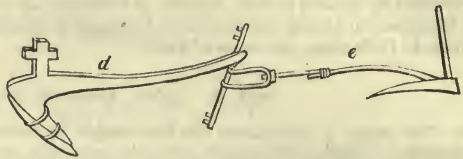

them, till it acquires a velocity sufficient to enable them to throw the water over a bank into a canal. They work stark naked, or if in summer only with a slight blue cotton shirt or belt." (*Clarke's Travels, &c.*)

12. *Of these immense embankments*, some of which served to keep in the river, and others to oppose the torrents of sand which occasionally were blown from the Great Desert, and which threatened to cover the country as effectually as the waters of the Nile, the ruins still remain. But in spite of these remains, the sand is accumulating, and the limits of cultivated Egypt have been annually decreasing for the last 1200 years; the barbarous nations to which the banks of the Nile have been subject during this period having paid no attention to cultivation, or the preservation of these noble works of antiquity.

13. *Landed property*, in ancient Egypt, it would appear, was the absolute right of the owners, till by the procurement of Joseph, in the eighteenth century B. C., the paramount or allodial property of the whole was transferred to the government. The king, however, made no other use of that right, than to place the former occupiers in the situation of tenants *in capite*; bound to pay a rent or land-tax of one fifth of the produce. This, Moses says, continued to be the law of Egypt down to his time; and the same thing is confirmed by the testimony of Herodotus and Strabo.

14. *The soil of Egypt* is compared by Pliny to that of the Leontines, formerly regarded as the most fertile in Sicily. There, he says, corn yields a hundred for one; but Cicero, as Gouguet observes, has proved this to be an exaggeration, and that the ordinary increase in that part of Sicily is eight for one. Granger (*Relat. du Voy. fait en Egypte, 1730.*), who paid much attention to this subject, says that the lands nearest to the Nile, which during the inundation were covered with water forty days, did not, in the most favorable seasons, yield more than ten for one; and that those lands which the water covered only five days, seldom gave more than four for one. This, however, is probably owing to their present neglected state.

15. *Of the animal or vegetable products of Egyptian agriculture*, very little is known. The ox seems to have been the chief animal of labor from the earliest period; and rice at all times the principal grain in cultivation. By a painting discovered in the ancient Elethia, (*fig. 6.*) it would appear the operation of reaping was performed much in the same way as at present, the ears being cropped by a hook, and the principal part of the straw left as stubble. Herodotus mentions, that, in his time, wheat was not cultivated, and that the bread made from it was despised, and reckoned not fit to be eaten. Beans were also held in abhorrence by the ancient inhabitants: but it is highly probable, that in latter times, when they began to have commerce with other nations, they would lay aside these and other prejudices, and cultivate what they found best suited to the foreign market.



16. *Agriculture was no doubt the chief occupation of the Egyptians*: and though they are said to have held the profession of shepherd in abhorrence, yet it appears Pharaoh not only had considerable flocks and herds in his own possession, but was desirous of introducing any improvement which might be made in their management: for when Jacob, in answer to his questions, told him, that he and his family had been brought up to the care of live stock from their youth, he expressed a wish to Moses to have a Jewish bailiff for the superintendence of his grazing farm: "if thou knowest any men of activity among them, then make them rulers over my cattle." (*Gen. xlvii. 6.*)

#### SECT. II. *Of the Agriculture of the Greeks.*

17. *The aboriginal Greeks or Pelasgi* were civilised by colonies from Egypt, and received from that country their agriculture, in common with other arts and customs. Some of the ancient Greeks pretend that the culture of corn was taught them by Ceres; but Herodotus and most of the ancients concur in considering this divinity as the same with the Egyptian Isis. There is no particular evidence that the Greeks were much attached to, or greatly improved agriculture; though Homer gives us a picture of old King Laertes, divested of wealth, power, and grandeur, and living happy on a little farm, the fields of which were well cultivated. (*Odyssey, lib. xxiv.*) On another occasion, he represents a king standing amongst the reapers, and giving them directions by pointing with his sceptre. (*Ibid. v. 550.*) Xenophon highly commends the art; but the practical instances he refers to, as examples, are of Persian kings.

18. *What we know of the agriculture of Greece*, is chiefly derived from the poem of Hesiod, entitled *Works and Days*. Some incidental remarks on the subject may be found in the writings of Herodotus, Xenophon, Theophrastus, and others. Varro, a Roman, writing in the century preceding the commencement of our æra, informs us, that there were more than fifty authors, who might at that time be consulted on the sub-

ject of agriculture, all of which were ancient Greeks, excepting Mago the Carthaginian. Among them he includes Democritus, Xenophon, Aristotle, Theophrastus, and Hesiod. The works of the other writers he enumerates, have been lost; and indeed all that remains of Democritus are only a few extracts preserved in the *Geoponika*, an agricultural treatise published at Constantinople by the Greeks of the fourth or fifth centuries of our æra. Xenophon, Aristotle, Homer, and others, touch on our subject but very slightly. Xenophon, after his banishment to Scillus, is said to have spent his time in literary pursuits, and in improving and decorating his estate; he wrote a treatise expressly on rural and domestic affairs, the third book of which is devoted to agriculture, entitled *Economics*, in the form of a dialogue, and is even said to have given lessons on the subject. Of his treatise, Harté (*Essays*, p. 201.) says, "I take it to be one of the plainest and most sensible performances amongst the writings of the ancients." Theophrastus, a disciple of Aristotle, wrote on natural history, and his history of plants possesses an astonishing degree of merit, for the age in which it was written. He is justly considered the father of botany, and his work contains some curious observations on soils and manures, and on various parts of agriculture and gardening.

19. *But the writings of Hesiod are the chief resource for details as to Grecian agriculture.* This author flourished in the tenth century B. C., and was therefore contemporary with Homer. He lived at Askra, a village at the foot of Mount Helicon, in Bœotia. There he kept a flock, and cultivated a soil, which he describes as "bad in winter, hard in summer, and never good," probably a stiff clay. As a poet who had written on various subjects, Hesiod was held in great veneration; and Aristotle states, that when the Thesprotians destroyed the village of Askra, and the Orchomenians received the fugitives who escaped, the oracle ordered them to send for the remains of the poet who had given celebrity to the place.

20. *The works of Hesiod, which constitute the first parts of his Poem, are not merely details of agricultural labors, but comprise directions for the whole business of family economy in the country.* The poem sets out by describing the state of the world, past and present, for the purpose of exemplifying the condition of human nature. This condition entails on man the necessity of exertion to preserve the goods of life, and leaves him no alternative but honest industry or unjust violence; of which the good and evil consequences are respectively illustrated. Dissension and emulation are represented as two principles actively at work: much is said of the corruption of judges, and the evils of litigation: contentment is apostrophised as the true secret of happiness; virtue and industry strongly recommended. The poet now proceeds to describe the prognostics of the seasons of agricultural labor, and gives directions for providing a house, wife, slaves, and two steers: how and when to cut down timber; to construct carts and ploughs, and make clothes and shoes; when to sow, reap, dress the vine, and make wine. He then treats of navigation, and gives cautions against risking every thing in one voyage: he describes the fit seasons for the coasting trade, and advises taking great care of the vessel at such time as she is not in use, and hanging up the rudder and other tackle in the smoke of the chimney. He concludes the "works" with some desultory precepts of religion, personal propriety, and decorum; and enjoins some curious superstitious observances relative to family matters. The *Days* contains a division of the lunar month into holy, auspicious, and inauspicious, mixed and intermediary days, the latter being such as are entitled to no particular observance.

21. *Property in land, among the Greeks, seems to have been absolute in the owner, or what we would term freehold.* The manner of inheritance seems to have been that of gavel-kind; the sons dividing the patrimony in equal portions. One of Solon's laws forbade that men should purchase as much land as they desired. An estate containing water, either in springs or otherwise, was highly valued, especially in Attica: and there a law existed relating to the depth of wells; the distance they were to be dug from other men's grounds; what was to be done when no water was found; and other matters to prevent contentions as to water. Lands were enclosed, probably with a ring-fence, or boundary-mark; or, most likely the enclosed lands were such as surrounded the villages, and were in constant cultivation; the great breadth of country being, it may be presumed, in common pasture. Solon decrees, that "he who digs a ditch, or makes a trench nigh another's land, shall leave so much distance from his neighbor, as the ditch or trench is deep. — If any one makes a hedge near his neighbor's ground, let him not pass his neighbor's land-mark; if he builds a wall, he is to leave one foot between him and his neighbor; if a house, two feet. A man building a house in his field must place it a bow-shot from his neighbor's." (*Potter's Antiq.*)

22. *The surface of Greece was, and is, irregular and hilly, with rich vales, and some rocky places and mountains; the soil is various; clayey in some places, but most generally light and sandy, on a calcareous subsoil.*

23. *The operations of culture, as appears by Hesiod, required to be adapted to the season: summer fallows were in use, and the ground received three ploughings, one in*

autumn, another in spring, and a third immediately before sowing the seed. Manures were applied: in Homer, an old king is found manuring his fields with his own hands; and the invention of manures is ascribed by Pliny to the Grecian king Augeas. Theophrastus enumerates six different species of manures; and adds, that a mixture of soils produces the same effects as manure. Clay, he says, should be mixed with sand, and sand with clay. The seed was sown by hand, and covered with a rake. Corn was reaped with a sickle; bound in sheaves; carted to a well-prepared threshing-floor, in an airy situation, where it might be threshed and fanned by the wind, as is still practised in modern Greece, Italy, and other countries of the continent. Afterwards it was laid up in bins, or chests, or granaries, and taken out as wanted by the family to be pounded in mortars, or quern-mills into meal. Thorns and other plants for hedges were procured from the woods, as we find from a passage in Homer, in which he represents Ulysses as finding Laertes digging and preparing to plant a row of quick-sets. (*Odys.* lib. xxiv.)

24. *The implements* enumerated by Hesiod, are a plough, of which he recommends two to be provided in case of accident; a cart with two low wheels, and ten spans (seven feet six inches) in width. The plough consisted of three parts; the share-beam, the draught-pole, and the plough-tail. The share-beam is to be made of oak, and the other parts of elm or bay: they are to be joined firm with nails. Antiquarians are not agreed as to the exact form of this implement. Gouguet conjectures it may not have been unlike one still in use in the same countries, and in the south of France: others, with greater probability, refer to the more simple plough still in use in Magna Grecia and Sicily (*fig. 7.*), originally Greek colonies. The rake, sickle, and oxen-goad, are mentioned; but nothing said of their construction, or of spades, or other manual implements.

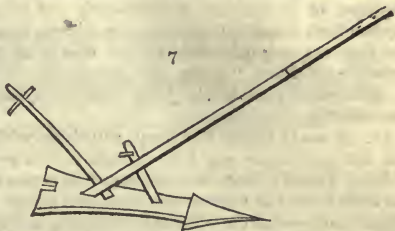

25. *The beasts of labor* mentioned, are oxen and mules: the former were most common; and it would appear, from a passage in Homer (*Il.* lib. xiii. v. 704.) were yoked by the horns. Four and a half years is recommended as the best age for purchasing oxen: in winter, both oxen and mules were fed under cover, on hay and straw, mast, and the leaves of vines and various trees.

26. *The most desirable age for a ploughman* is forty: he must be well fed, go naked in summer, rise and go to work very early, and have a sort of annual feast, proper rest, and good food and clothing:—coats of kid skins, worsted socks, and half boots of ox hides in winter. He must not let his eye wander about while at plough, but cut a straight furrow; nor be absent in mind when sowing the seed, lest he sow the same furrow twice. The vine is to be pruned and staked in due season; the vintage made in fine weather, and the grapes left a few days to dry, and then carried to the press.

27. *The products of Grecian agriculture*, were sheep, goats, swine, cattle, mules, asses, and horses: the grains and legumes at present in cultivation; and the vine, fig, olive, apple, date, and other fruits. It does not appear that artificial grasses or herbage plants were in use; but recourse was had, in times of scarcity, to the mistletoe and the cytissus: what plant is meant by the latter designation is not agreed on; some consider it the medicago arborea, Linn., and others the common lucerne. Hay was, in all probability, obtained from the meadows and pastures, which were used in common: flax, and probably hemp, was grown. Wood for fuel, and timber for construction, were obtained from the natural forests, which, in Solon's time, abounded with wolves. Nothing is said of the olive or fig by Hesiod; but they were cultivated in the fields for oil and food, as well as the vine for wine. One of Solon's laws directs, that olive and fig trees must be planted nine feet from a neighbour's ground, on account of their spreading roots: other trees might be planted within five feet.

28. *In Hesiod's time almost every citizen was a husbandman*, and had a portion of land which he cultivated himself, with the aid of his family, and perhaps one or two slaves; and the produce, whether for food or clothing, appears to have been manufactured at home. The progress of society would, no doubt, introduce the usual division of labor and of arts; and commercial cultivators, or such as raised produce for the purpose of exchange, would in consequence arise; but when, and to what extent this was carried, at the time Greece became a Roman province (B. C. 100), the ancient writers afford us no means of ascertaining.

### SECT. III. *Of the Agriculture of the Jews, and other nations of Antiquity.*

29. *Of the agriculture of the nations contemporary with the Egyptians and Greeks* nothing is distinctly known; but assuming it as most probable that agriculture was first brought into notice in Egypt, it may be concluded that most other countries, as well as Greece, would begin by imitating the practices of that country.

30. On the agriculture of the Jews, we find there are various incidental remarks in the books of the Old Testament. On the conquest of Canaan, it appears that the different tribes had their territory assigned them by lot; that it was equally divided among the heads of families, and by them and their posterity held by absolute right, and impartial succession. Thus every family had originally the same extent of territory; but as it became customary afterwards to borrow money on its security; and as some families became indolent and were obliged to sell, and others extinct by death without issue, landed estates soon varied in point of extent. In the time of Nehemiah a famine occurred, on which account many had "mortgaged their lands, their vineyards, and houses, that they might buy corn for their sons and daughters; and to enable them to pay the king's tribute." (*Nehem. v. 2.*) Some were unable to redeem their lands otherwise than by selling their children as slaves, and thereby "bringing the sons and daughters of God into bondage." Boaz came into three estates by inheritance, and also a wife, after much curious ceremony. (*Ruth i. 8. iv. 16.*) Large estates, however, were not approved of. Isaiah pronounces a curse on those "that join house to house, that lay field to field, till there be no place, that they may be placed alone in the midst." While some portions of land near the towns were enclosed, the greater part was in common, or in alternate proprietorship and occupation, as in our common fields. This appears both from the laws and regulations laid down by Moses as to herds and flocks; and from the story of widow Naomi, who in the progress of her manœuvres to ingratiate herself with Boaz, "came and gleaned in the field after the reapers, and her hap was to light on a part of the field, (that is, of the common field,) belonging unto Boaz." (*Ruth ii. 3.*)

31. It would appear that every proprietor cultivated his own lands, however extensive; and that agriculture was held in high esteem even by their princes. The crown-lands, in King David's time, were managed by seven officers: one was over the store-houses, and others over the work of the field, and tillage of the ground—over the vineyards and wine-cellar—over the olive and oil-stores, and sycamore (*Ficus sycamorus*, Linn.) plantations—over the herds—over the camels and asses—and over the flocks. (*1 Chron. xxvii. 25.*) King Uzziah "built towers in the desert, and digged many wells; for he had much cattle both in the low country and in the plains; husbandmen also and vine-dressers in the mountains, and in Carmel, for he loved husbandry." (*2 Chron. xxvi. 10.*) Even private individuals cultivated to a great extent, and attended to the practical part of the business themselves. Elijah found Elisha in the field with twelve yoke of oxen before him, and himself with the twelfth. Job had five hundred yoke of oxen, and five hundred she-asses, seven thousand sheep, and three thousand camels. Both asses and oxen were used in ploughing; for Moses forbade the Jews to yoke an ass with an ox, their step or progress being different, and of course their labors unequal.

32. Among the operations of agriculture are mentioned watering by machinery, ploughing, digging, reaping, threshing, &c. "The ploughman plougheth all day to sow; he openeth and breaketh the clods of his ground. When he hath made plain the face thereof, doth he not cast abroad the fitches, and scatter the cummin (*Cuminum cyminum*, Linn.), and cast in the principal wheat, and the appointed barley, and the rye, in their place?" (*Isaiah xxviii. 24, 25.*) The plough was probably a clumsy instrument, requiring the most vigilant attention from the ploughman, for Luke (ch. ix. 62.) uses the figure of a man at plough looking back as one of utter worthlessness. Covered threshing-floors were in use; and as appears from the case of Boaz and Naomi, it was no uncommon thing to sleep in them during harvest. Corn was threshed in different ways, "the fitches," says Isaiah, "are not threshed with a threshing-instrument, neither is a cart-wheel turned about upon the cummin; but the fitches are beaten out with a staff, and cummin with a rod (flail); bread-corn is bruised, because he will not be ever threshing it, nor break it with the wheel of his cart, nor bruise it with his horsemen." (Ch. xxviii. 27, 28.) The bread-corn here mentioned was probably the *far* of the Romans (maize, *Zea mays*, L.), which was commonly separated by hand-mills, or hand-picking, or beating, as is still the case in Italy and other countries where this corn is grown. Corn was "winnowed with the shovel and with the van." (*Id. xxx. 24.*) Sieves were also in use, for Amos says, "I will sift the house of Israel as corn is sifted in a sieve." (Ch. ix. 9.) And Christ is represented by St. Luke as saying, "Simon, Simon, Satan hath desired to have you, that he may sift you as wheat." Isaiah mentions (vii. 25.) the "digging of hills with the mattock:" to which implement the original pick (fig. 2.) would gradually arrive, first, by having the head put on at right angles, and pointed (fig. 8. a); next, by having it flattened, sharpened, and shod with iron (b, c); and lastly, by forming the head entirely of

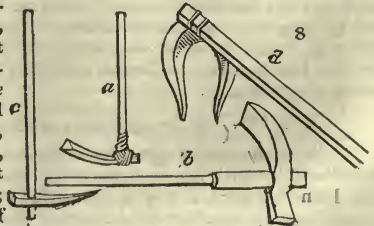

metal, and forked (*d*), such probably as we see it in use in Judea, and the land of Canaan, at the present day.

33. *Vineyards* were planted on rising grounds, fenced round, the soil well prepared, and a vintage-house and watch-tower built in a central situation (*Isaiah* v. 2.), as is still done in European Turkey and Italy. Moses gives directions to the Jews for cultivating the vine and other fruit-trees; the three first years after planting, the fruit is not to be eaten; the fourth, it is to be given to the Lord; and it is not till the fifth year that they are "to eat of the fruit thereof." (*Levit.* xix. 25.) The intention of these precepts was to prevent the trees from being exhausted by bearing before they had acquired sufficient strength and establishment in the soil.

34. *Of other agricultural operations and customs*, it may be observed with Dr. Brown, (*Antiq. of the Jews*, vol. ii. part xii. sect. 5, 6.), that they differed very little from the existing practices in the same countries as described by modern travellers.

35. *The agricultural produce of the Jews* was the same as among the Egyptians; corn, wine, oil, fruits, milk, honey, sheep, and cattle, but not swine. The camel then, as now, was the beast of burden, and long journeys (*fig. 9.*); and the horse, the animal of war and luxury. The fruit of the sycamore-fig was abundant, and in general use; and grapes



attained an astonishing size, both of berry and bunch; the melon and gourd tribes were common. The returns of corn were in general good; but as neither public stores, nor corn monopolisers, seem to have existed, dearths, and their attendant miseries, happened occasionally. A number of these are mentioned in Scripture, and some of extraordinary severity.

36. *Of the agriculture of the other civilized and stationary nations* of this period, scarcely any thing is known. According to Herodotus, the soil of *Babylon* was rich, well cultivated, and yielded two or three hundred for one. Xenophon, in his book of *Æconomics*, bestows due encomiums on a Persian king, who examined, with his own eyes, the state of agriculture throughout his dominions; and in all such excursions, according as occasion required, bountifully rewarded the industrious, and severely discountenanced the slothful. In another place he observes, that when Cyrus distributed premiums with his own hand to diligent cultivators, it was his custom to say, "My friends, I have a like title with yourselves to the same honors and remuneration from the public; I give you no more than I have deserved in my own person; having made the self-same attempts with equal diligence and success." (*Æconom.* c. iv. sect. 16.) The same author elsewhere remarks, that a truly great prince ought to hold the arts of war and agriculture in the highest esteem; for by such means he will be enabled to cultivate his territories effectually, and protect them when cultivated. (*Harte's Essays*, p. 19.)

37. *Phœnicia*, a country of Asia, at the east of the Mediterranean, has the reputation of having been cultivated at an early period, and of having colonised and introduced agriculture at Carthage, Marseilles, and other places. The Phœnicians are said to have been the original occupiers of the adjoining country of Canaan; and when driven out by the Jews, to have settled in Tyre and Sidon (now Sur and Saida), in the fifteenth century B. C. They were naturally industrious; and their manufactures acquired such a superiority over those of other nations, that among the ancients, whatever was elegant, great, or pleasing, either in apparel or domestic utensils, was called Sidonian; but of their agriculture it can only be conjectured that it was Egyptian, as far as local circumstances would permit.

38. *The republic of Carthage* included Spain, Sicily, and Sardinia, and flourished for upwards of seven centuries previous to the second century B. C. Agriculture was practised at an early period in Sicily; and, according to some, Greece received that art from this island. It must have been also considerably advanced in Spain, and in the Carthaginian territory, since they had books on the subject. In 147 B. C., when Carthage was destroyed by Scipio, and the contents of the libraries were given in presents to the princes, allies of the Romans, the senate only reserved the twenty-eight books on agriculture of the Carthaginian general Magon, which Decius Syllanus was directed to translate; and of which the Romans preserved, for a long time, the original and the translation. (*Encyc. Méthodique*, art. *Agriculture.*)

39. *Italy*, and a part of the south of *France*, would probably be partially cultivated from the influence of the Carthaginians in Sicily and Marseilles; but the north of France, and the rest of Europe, appear to have been chiefly, if not entirely, in a wild

state, and the scene of the pastoral and hunting employments of the nomadic nations, the Kelts or Celts, the Goths, and the Slaves.

40. *The Indian and Chinese nations* appear to be of equal antiquity with the Egyptians. Joseph de Guignes, an eminent French Oriental scholar, who died in the first year of the present century, has written a memoir (in 1759, 12mo.), to prove that the Chinese were a colony from Egypt: and M. de Guignes, a French resident in China, who published at Paris a Chinese dictionary in 1813, is of the same opinion. The histories of the Oriental nations, however, are not yet sufficiently developed from the original sources, to enable us to avail ourselves of the information they may contain as to the agriculture of so remote a period as that now under consideration.

41. With respect to *the American nations* during this period, there are no facts on record to prove either their existence or their civilisation, though Bishop Huet, and the Abbé Clavigero, think that they also are descendants of Noah, who, while in a nomadic state, arrived in the western, through the northern parts of the eastern continent.

## CHAP. II.

*History of Agriculture among the Romans, or from the Second Century B. C. to the Fifth Century of our æra.*

42. We have now arrived at a period of our history where *certainty supplies the place of conjecture*, and which may be considered as not only entertaining but instructive. The attention of the Romans to agriculture is well known. The greatest men amongst them applied themselves to the study and practice of it, not only in the first ages of the state, but after they had carried their arms into every country of Europe, and into many countries of Asia and Africa. Some of their most learned men, and one of their greatest poets wrote on it; and all were attached to the things of the country. Varro, speaking of the farms of C. Tremellius Scrofa, says, "they are to many, on account of their culture, a more agreeable spectacle than the royally ornamented edifices of others." (*Var. de R. R. lib. i. cap. 2.*) In ancient times, Pliny observes, the lands were cultivated by the hands, even of generals, and the earth delighted to be ploughed with a share adorned with laurels, and by a ploughman who had been honored with a triumph. (*Nat. Hist. lib. xviii. c. 3.*) The Romans spread their arts, with their conquests; and their agriculture became that of all Europe at an early period of our æra.

43. *The sources from which we have drawn our information* being first related, we shall review, in succession, the proprietorship, occupancy, soil, culture, and produce of Roman agriculture.

### SECT. I. *Of the Roman Agricultural Writers.*

44. *The Roman authors* on agriculture, whose works have reached the present age, are Cato, Varro, Virgil, Columella, Pliny, and Palladius. There were many more, whose writings are lost. The compilation of Constantine Poligonat, or, as others consider, of Cassius Bassus, entitled *Geoponica*, already mentioned (18.), is also to be considered as a Roman production, though published in the Greek language at Constantinople, after the removal thither of the seat of government.

45. M. Porcius Cato, called the Censor, and the father of the Roman rustic writers, lived in the seventh century of the republic, and died at an extreme old age, B. C. 150. He recommended himself, at the age of seventeen, by his valor in a battle against Annibal; and afterwards rose to all the honors of the state. He particularly distinguished himself as censor, by his impartiality and opposition to all luxury and dissipation; and was remarkably strict in his morals. He wrote several works, of which only some fragments remain, under the titles of *Origines* and *De Re Rustica*. The latter is the oldest Roman work on agriculture: it is much mutilated, and more curious for the account it contains of Roman customs and sacrifices, than valuable for its georgical information.

46. M. Terentius Varro died B. C. 28, in the 88th year of his age. He was a learned writer, a distinguished soldier both by sea and land, and a consul. He was a grammarian, a philosopher, a historian, and astronomer; and is thought to have written five hundred volumes on different subjects, all of which are lost, except his treatise *De Re Rustica*. This is a complete system of directions in three books, on the times proper for, and the different kinds of, rural labour; it treats also of live stock, and of the villa and offices. As Varro was for some time lieutenant-general in Spain and Africa, and afterwards retired and cultivated his own estate in Italy, his experience and observation must have been very considerable.



47. Publius *Virgilius* Maro, called the prince of the Latin poets, was born at a village near Mantua in Lombardy about 70 B. C., and died B. C. 19, aged 51. He cultivated his own estate till he was 30 years old, and spent the rest of his life chiefly at the court of Augustus. His works are the *Bucolics*, *Georgics*, and *Æneid*. The *Georgics* is to be considered as a poetical compendium of agriculture, taken from the Greek and Roman writers then extant, but especially from Varro.

48. Luc. Jun. Moderatus *Columella* was a native of Gades, now Cadiz, in Spain, but passed most of his time in Italy. The time of his birth and death are not known, but he is supposed to have lived under Claudius in the first century. His work *De Re Rustica*, lib. xii. is a complete treatise on rural affairs; including field operations, timber-trees, and gardens.

49. *C. Plinius Secundus*, surnamed the elder, was born at Verona in Lombardy, and suffocated at the destruction of Pompeii in his 56th year, A. D. 79. He was of a noble family; distinguished himself in the field and in the fleet; was governor of Spain; was a great naturalist, and an extensive writer. Of the works which he composed none are extant but his *Natural History* in thirty-seven books; a work full of the erudition of the time, accompanied with much erroneous, useless, and frivolous matter. It treats of the stars, the heavens, wind, rain, hail, minerals, trees, flowers, and plants; an account of all living animals, birds, fishes, and beasts; a geographical description of every place on the globe; a history of every art and science, commerce, and navigation, with their rise, progress, and several improvements. His work may be considered as a compendium of all preceding writers on these subjects, with considerable additions from his personal experience and observation.

50. Rutilius Taurus *Emilianus Palladius* is by some supposed to have lived under Antoninus Pius, in the second, and by others in the fourth century. His work *De Re Rustica* is a poem in fourteen books, and is little more than a compendium of those which preceded it on the same subject. The editor of the article Agriculture, in the *Encyclopédie Méthodique*, says it is too dull to be read as a poem, and too concise to be useful as a didactic work.

51. These works have been rendered accessible to all by translations; and a judicious and instructive treatise composed from them by Adam Dickson, a Scotch clergyman, was published in 1788, under the title of *The Husbandry of the Ancients*. To this last work we are indebted for the greater part of what we have to submit on Roman agriculture.

52. The Roman authors, as Rozier has observed (*Dict. de l'Agr. art. Hist.*), do not enable us to trace the rise and progress of agriculture, either in Italy or in any other country under their dominion. What they contain is a picture of their rural economy in its most perfect state: delivered in precepts, generally founded on experience, though sometimes on superstition; never, however, on theory or hypothesis. For, as the Rev. Adam Dickson states, "instead of schemes produced by a lively imagination, which we receive but too frequently from authors of genius unacquainted with the practice of agriculture, we have good reason to believe that they deliver in their writings, a genuine account of the most approved practices; practices, too, the goodness of which they had themselves experienced." (*Husb. of the Anc.* p. 16.) He adds, that if in the knowledge of the theory of agriculture, the Roman cultivators are inferior to our modern improvers; yet in attention to circumstances and exactness of execution, and in economical management, they are greatly superior.

## SECT. II. Of the Proprietorship, Occupancy, and General Management of Landed Property among the Romans.

53. The Roman nation originated from a company of robbers and runaway slaves, who placed themselves under their leader Romulus. This chief having conquered a small part of Italy divided the land among his followers, and by what is called the Agrarian Law, allowed 2 jugera or  $1\frac{1}{2}$  acre to every citizen. After the expulsion of the kings in the 6th century B. C., 7 yoke, or  $3\frac{1}{2}$  acres were allotted. The custom of distributing the conquered lands, by giving 7 jugera to every citizen, continued to be observed in latter times; but when each soldier had received his share, the remainder was sold in lots of various sizes, even to 50 jugera; and no person was prevented from acquiring as large a landed estate as he could, till a law passed by Stolo, the second plebeian consul, B. C. 377, that no one should possess more than 500 jugera. This law appears to have remained in force during the greater period of the Roman power. Whatever might be the size of the estate, it was held by the proprietor as an absolute right, without acknowledgment to any superior power; and passed to his successors, agreeably to testament, if he made one; or if not, by common law to his nearest relations.

54. In the first ages of the commonwealth, the lands were occupied and cultivated by the proprietors themselves; and as this state of things continued for four or five centuries, it was probably the chief cause of the agricultural eminence of the Romans. When a

person has only a small portion of land assigned to him, and the maintenance of his family depends entirely upon its productions, it is natural to suppose that the culture of it employs his whole attention. A person who has been accustomed to regular and systematic habits of action, such as those of a military life, will naturally carry those habits into whatever he undertakes. Hence, it is probable, a degree of industrious application, exactness, and order in performing operations, by a soldier-agriculturist, which would not be displayed by men who had never been trained to any regular habits of action. The observation of Pliny confirms this supposition: he asserts that the Roman citizens, in early times, "ploughed their fields with the same diligence that they pitched their camps, and sowed their corn with the same care that they formed their armies for battle." (*Nat. Hist.* lib. xviii. c. 3.) Corn, he says, was then both abundant and cheap.

55. *Afterwards, when Rome extended her conquests, and acquired large territories, rich individuals purchased large estates; the culture of these fell into different hands, and was carried on by bailiffs and farmers much in the same way as in modern times. Columella informs us that it was so in his time, stating, that "the men employed in agriculture are either farmers or servants; the last being divided into free servants and slaves."* (*Col.* lib. i. cap. 7.) It was a common practice to cultivate land by slaves during the time of the elder Pliny; but his nephew and successor let his estates to farmers.

56. *In the time of Cato the Censor, the author of The Husbandry of the Ancients observes, though the operations of agriculture were generally performed by servants, yet the great men among the Romans continued to give a particular attention to it, studied its improvement, and were very careful and exact in the management of all their country affairs. This appears from the directions given them by this most attentive farmer. Those great men had both houses in town, and villas in the country; and as they resided frequently in town, the management of their country affairs was committed to a bailiff or overseer. Now their attention to the culture of their lands and to every other branch of husbandry, appear from the directions given them how to behave upon their arrival from the city at their villas. "After the landlord," says Cato, "has come to the villa, and performed his devotions, he ought that very day, if possible, to go through his farm; if not that day, at least the next. When he has considered in what manner his fields should be cultivated, what work should be done, and what not; next day he ought to call the bailiff, and enquire what of the work is done, and what remains; whether the laboring is far enough advanced for the season, and whether the things that remain might have been finished; and what is done about the wine, corn, and all other things. When he has made himself acquainted with all these, he ought to take an account of the workmen and working days. If a sufficiency of work does not appear, the bailiff will say that he was very diligent, but that the servants were not well; that there were violent storms; that the slaves had run away; and that they were employed in some public work. When he has given these and many other excuses, call him again to the account of the work and the workmen. When there have been storms, enquire for how many days, and consider what work might be done in rain; casks ought to have been washed and mended, the villa cleaned, corn carried away, dung carried out, go through hill made, seed cleaned, old ropes mended, new ones made, and the servants' clothes mended. On holidays, old ditches may have been scoured, a highway repaired, briars cut, the garden digged, meadows cleared from weeds, twigs bound up, thorns pulled, far (bread-corn, maize) pounded, all things made clean. When the servants have been sick, the ordinary quantity of meat ought not to have been given them. When he is fully satisfied in all these things, and has given orders that the work that remains be finished, he should inspect the bailiff's accounts, his account of money, of corn, fodder, wine, oil, what has been sold, what exacted, what remains, what of this may be sold, whether there is good security for what is owing. He should inspect the things that remain, buy what is wanting for the year, and let out what is necessary to be employed in this manner. He should give orders concerning the works he would have executed, and the things he is inclined to let, and leave his orders in writing. He should inspect his flocks, make a sale, sell the superfluous oil, wine, and corn; if they are giving a proper price, sell the old oxen, the refuse of the cattle and sheep, wool, hides, the old carts, old iron tools, and old and diseased slaves. Whatever is superfluous he ought to sell; a farmer should be a seller, not a buyer."* (*Cat.* cap. ii.)

57. *The landlord is thus supposed by Cato to be perfectly acquainted with every kind of work proper on his farm, and the seasons of performing it, and also a perfect judge how much work both without and within doors ought to be performed by any number of servants and cattle, in a given time; the knowledge of which is highly useful to a farmer and what very few perfectly acquire. It may be observed likewise, that the landlord is here supposed to enquire into all circumstances, with a minuteness of which there is scarcely even an actual farmer in this age that has any conception.*

58. *Varro complains that, in his time, the same attention to agriculture was not given as in former times; that the great men resided too much within the walls of the city, and employed themselves more in the theatre and circus, than in the corn-fields and vineyards.* (*Var. de R. R.* lib. i. *Præf.*)

59. *Columella complains that, in his time, agriculture was almost entirely neglected. However, from the directions which he gives to the proprietors of land, it appears that there were still a few that continued to pay a regard to it; for, after mentioning some things, which he says, by the justice and care of the landlord, contribute much to improve his estate, he adds, "But he should likewise remember, when he returns from the city, immediately after paying his devotions, if he has time, if not, next day, to view his marches, inspect every part of his farm, and observe whether in his absence any part of discipline or watchfulness has been dispensed with; and whether any vine, any other tree, or any fruits are missing. Then likewise he ought to review the cattle and servants, all the instruments of husbandry, and household furniture. If he continues to do all these things for some years, he will find a habit of discipline established when he is old; and*

at no age will he be so much impaired with years as to be despised by his servants." (Col. lib. i. cap. 9.)

60. *The earliest farmers among the Romans* seem not to have been upon the same footing as in Britain. The stock on the farm belonged to the landlord, and the farmer received a certain proportion of the produce for his labor. The farmer, who possessed a farm upon these terms, was called *politor* or *polintor*, from his business, being the dresser of the land; and *partuarius*, from his being in a kind of co-partnership with his landlord, and his receiving a part of the produce of the farm for his labor. Cato takes notice of this kind of farmers only, and it is probable that there were no others in his time. "The terms," says he, "upon which land ought to be let to a *politor*; in the good land of Casinum and Venafrum, he receives the eighth basket; in the second kind of land he receives the seventh; in the third kind he receives the sixth. In this last kind, when the grain is divided by the *modius*, he receives the fifth part; in the very best kind of land about Venafrum, when divided by the basket, he receives only the ninth. If the landlord and *politor* husk the *far* in common, the *politor* receives the same proportion after as before; of barley and beans divided by the *modius*, he receives a fifth." (Ch. xl. xli.) The small proportion of the produce that the *politor* received, makes it evident that he was at no expence in cultivating the land, and that he received his proportion clear of all deductions.

61. *The coloni, or farmers mentioned by Columella*, seem to have paid rent for their farms in the same manner as is done by the farmers in Britain. The directions given by this author to landlords concerning the mode of treating them, are curious as well as important. A landlord, he says, ought to treat his tenants with gentleness, should show himself not difficult to please, and be more vigorous in exacting culture than rent, because this is less severe, and upon the whole more advantageous. For, where a field is carefully cultivated, it for the most part brings profit, never loss, except when assaulted by a storm or pillagers; and therefore the farmer cannot have the assurance to ask any ease of his rent. Neither should the landlord be very tenacious of his right in every thing to which the farmer is bound, particularly as to days of payment, and demanding the wood and other small things which he is obliged to, besides paying his rent, the care of which is a greater trouble than expense to the rustics. Nor is every penalty in our power to be exacted, for our ancestors were of opinion, that the rigor of the law is the greatest oppression. On the other, the landlord ought not to be entirely negligent in this matter; because it is certainly true, what Alpheus the usurer used to say, that good debts become bad ones, by being not called for. I remember to have heard it asserted by L. Volusius, an old rich man, who had been consul, that an estate was most advantageous to the landlord, which was cultivated by farmers, natives of the country, and born upon the lands, for these are attached to it by a strong habit from their cradles. So, indeed, it is my opinion, that the frequent letting of a farm is a bad thing; however, it is still worse to let one to a farmer who lives in town, and chooses rather to cultivate it by servants than by himself. Saserna used to say, that from such a farm a lawsuit was got in place of rent. For which reason, we ought to be careful to retain in our farms the same industrious farmers that have been bred in the country, when it is not in our power to cultivate them ourselves, or convenient to do it by domestics; which, however, cannot happen except in those countries that are laid waste by the severity of the climate, or barrenness of the soil. For wherever the climate is moderately healthful, and the soil moderately good, lands never produce so much under the care of a farmer, as under the care of a landlord, or even of a bailiff, unless his very great negligence or rapaciousness prevent it, both of which are, for the most part, owing to the fault of the landlord; for it is in his power to prevent such a person from having the management of his affairs, or to remove him if placed in that office. However, in farms that lie at a distance, to which the landlord has not easy access, as all kinds of them are better under the management of free farmers than under bailiffs, so particularly corn farms, which a farmer cannot destroy, as he can a vineyard and other plantations; for when such farms are cultivated by distant landlords, the oxen are greatly harassed, these and the other cattle ill fed, the land ill ploughed, and much more seed charged than sown. Besides these things, the produce of the land is not managed in such a manner as to turn out to any account; for, when the corn is brought to the threshing-floor, during the threshing it is daily lessened by fraud or negligence; the servants themselves carry it off, and they allow it to be carried off by thieves; nor even after it is laid up, is it faithfully accounted for; so that, when the manager and servants are in the fault, the land is rendered infamous. Wherefore a farm of this kind, if, as I have said, the landlord cannot be on the spot, in my opinion ought to be let. (Col. lib. i. cap. 7.)

62. *These directions are valuable even with reference to the present times*; and they instruct us respecting the general management of landed property among the Romans. It appears that the landlord was considered as understanding every thing respecting the usbandry of his estate himself; and that there was no agent, or intermediate person,

between him and the farmer. The farmers paid rent for the use of their farms, and were bound to a particular kind of culture, according to the conditions of their lease; but they were perfectly free and independent of their landlords; so much so, as sometimes to enter into lawsuits with them. On the whole they seem to have been upon the same footing as the farmers of Britain in modern times.

SECT. III. *Of the Surface, Soil, Climate, and other Agricultural Circumstances of Italy, during the time of the Romans.*

63. *The agriculture of any country must necessarily take its character from the nature of that country.* The extent and manner of cultivating the soil, and the kind of plants cultivated, or animals reared, must necessarily be regulated by the surface of the soil, the natural productions, the climate, the artificial state, and the habits of the people.

64. *The climate of Italy* is regular, dry, clear, and, as every body knows, considerably warmer than that of Britain. At the bottoms of the mountains, it is subject to severe storms of hail in summer, and snow in winter, which often do considerable damage; but these are but accidental disadvantages; and in the champaign lands and gentle declivities, the vine, the fig, and the olive, ripened anciently, as now, in open plantations from one extremity of Italy to the other.

65. *The surface of Italy*, as every reader knows, is very irregular. A ridge of hills and mountains passes through its whole length, forming numerous valleys of different degrees of extent; some elevated and narrow, others low and watered by a river, a stream, or by lakes. The immense plain of the Po constitutes a capital feature towards the north-east; the sandy plain of Calabria towards the south; the marshy plain of Ferracino, and the rocky coast of Genoa, towards the western shore. Columella and Palladius agree in stating, that the best situation of lands, is not so much on a level as to make the water stagnate, nor so steep as to make it run off with violence; nor so low as to be buried in the bottom of a valley; nor so exposed as to feel the violence of storms and heats; but that in all these a mediocrity is always best; champaign lands exposed, and whose declivity affords the rain a free passage, or a hill whose sides gently decline, or a valley not too much confined, and into which the air has easy access, or a mountain defended by a higher top, and thereby secured from the winds that are most pernicious, or if high and rugged, at the same time covered with trees and grass. (*Col. lib. ii. cap. 2.; Pal. lib. i. cap. 5.*) The situation of lands which Cato reckons the best, is at the foot of a mountain with a south exposure. Varro and Pliny concur in this opinion, and the latter states that the best lands in Italy are so situated.

66. *The soil of Italy is as varied as the surface.* About Genoa a yellow marly clay forms a base to schistous cliffs and hilly slopes; a blue clay containing sulphur and alum on the west coast, between Florence and Venice; volcanic earth about Rome and Naples; sand about Florence, and at the estuaries of most of the rivers; rich black loam in the central parts of Tuscany; rich, deep, soft, moist earth, and mild marly clay, in Lombardy. Columella divides the soils of Italy into six kinds; fat and lean, free and stiff, wet and dry: these mixed with one another, he says, make great varieties. In common with all the other writers, he prefers a free soil.

67. *The native productions of Italy*, in an agricultural point of view, are, timber on the mountains, pastures on the hill sides, and meadow or very luxuriant grass-lands in the alluvial plains. The rich, low, and yet dry lands do not produce a close pasture, but a rough herbage, unless they are covered with trees; the sandy soils produce little of any thing; and the fens and marshes reeds and other coarse aquatics. Such were the productions of Italy antecedent to culture.

68. *The artificial state of the country*, in respect to agriculture, during the time of the Romans, seems to have differed less from its present state than will be imagined. The cultivated lands were open, and enclosures only to be seen near the villas. These were of small size, and chiefly gardens and orchards, excepting in the case of parks for game, formed by the wealthy, which never were very numerous. With the exception of part of Tuscany and Lombardy, this is still the case; and the landscape, as Daniel Malthus has observed (*Introd. to Girardin's Essay*), which Pliny observes as seen from his villas, does not appear to have been different two thousand years ago, from what it is at this day. But the roads, canals, markets, and artificial water-courses for the irrigation both of arable and grass lands, are undoubtedly greatly increased since the time of the Romans: though they also practised irrigation.

69. *The habits of a people* take their rise, in a great degree, from the climate in which they live, and the native or cultivated productions with which the country abounds. As respects agriculture, it may be sufficient to mention, that the great heat of the climate, by relaxing the frame, naturally produces indolence in many, and leads to a life of plunder in some. Hence then, as now, the danger from thieves and robbers in that country; and hence, also, the custom of performing field labors early in the morning, and in the evening, and resting during the mid-day heat. The general use of oil and wine as

food and drink, and also of the fig as an article of nourishment, are habits which arise mediately from the circumstance of these articles being the artificial produce of the country; but are ultimately, like most other habits, to be referred to the climate.

70. *These hints respecting the natural and agricultural geography of Italy*, during the time of the Romans, are confessedly *too scanty* to be of more use than to recal to the reader's recollection the information on the same subject with which his mind is already stored; and by this means to enable him to form a due estimate of the nature and merits of the agriculture which we are about to describe.

#### SECT. IV. *Of the Culture and Farm Management of the Romans.*

71. *The Roman authors are much more copious in describing farm culture and economy*, than in relating the state of landed property as to extent and proprietorship. Their directions, being founded on experience, are in great part applicable at the present day: they are remarkable for their minuteness; but we can only give a very brief compendium, beginning with some account of the farm and the villa, or farmery, and taking in succession the servants, beasts of labor, implements, operations, crops cultivated, animals reared, and profit produced.

##### SUBSECT. 1. *Of the Choice of a Farm, and of the Villa or Farmery.*

72. *In the choice of a farm*, Cato recommends a situation where there are plenty of artificers, and good water; which has a fortified town in its neighbourhood; is near the sea, or a navigable river, or where the roads are easy and good. (*Cat. cap. 1.*) To these requisites Varro adds, a proper market for buying and selling, security from thieves and robbers, and the boundaries planted with useful trees. The interior of the farm was not subdivided by inclosures, which were seldom used but for their gardens, and in the villas of the wealthy, to form a park.

73. *The soil preferred by Columella and all the Roman authors*, is the fat and free, as producing the greatest crops, and requiring the least culture: next, fat, stiff soil; then, stiff and lean soil, that can be watered; and, last of all, lean, dry soil.

74. *The state of a farm preferred by Cato and some other writers* is that of pasture, meadow, and watered grass-lands, as yielding produce at least expence; and lands under vines and olives, as producing the greatest profit according to the expence. The opinions of the Roman agriculturists, however, seem to disagree on the subject of meadows, apparently from confounding a profitable way of management, with a capacity of yielding great profit with superior management, and none without.

75. *The word Villa originally denoted a farm-house and its appurtenances*. In the first age of the commonwealth, these were very plain and small, suitable to the plain manners of the people, and adapted to the small size of their farms: but, when the Romans had extended their empire, when they had become rich and luxurious, and particular persons were possessed of large landed estates, then the villas became large and magnificent. In the time of Valerius Maximus, there were villas that covered more ground than was in the estates of some of the ancient nobles. "Now," says he, "those think themselves very much confined whose houses are not more extensive than the fields of Cincinnatus." (*Val. Max. lib. iv. cap. 4. sect. 7.*) In the days of Cato, it is probable that they had begun to extend their villas considerably, which makes him give a caution to the proprietors of land not to be rash in building. He recommends to them to sow and plant in their youth, but not to build till somewhat advanced in years. His words are remarkable: "A landholder," says he, "should apply himself to the planting of his fields early in his youth; but he ought to think long before he builds. He ought not to think about planting; but he ought to do it. When he is about thirty-six years of age, he may build, provided his fields are planted." (*Cat. cap. 3.*)

76. *Men should plant in their youth, and not build till their fields are planted*; and even then ought "not to be in a hurry, but take time to consider. It is best, according to the proverb, to profit by the folly of others." (*Plin. Nat. Hist. lib. xviii. cap. 5.*) The reason why these authors recommend greater attention to planting than building is, that the labouring oxen in Italy, in the time of the Romans, were fed, for several months in the year, with leaves and mast; and the vine, the fig, the olive, and other trees, were cultivated for their fruit.

77. *Build in such a manner that your villa may not need a farm, nor your farm need a villa*. (*Cat. cap. 3.*) Varro assigns proper reasons for this. "In not attending," says he, "to the measure of the farm, many have gone wrong. Some have made the villa much smaller, and others much larger than the farm required. One of these is contrary to a man's interest, and the other hurtful to the produce of his lands. For we both build and repair the larger buildings at a greater expence than is necessary; and, when the buildings are less than what the farm requires, the fruits are in danger of being destroyed." (*Var. de R. R. lib. i. cap. 11.*) Columella expresses himself to the same purpose, and mentions two persons in particular who had fallen into

each of the extremes. "I remember," says he, "that many have erred in this point, as these most excellent men did, L. Lucullus and Q. Scævola, one of whom built a *villa* much larger, and the other much less than the farm required." (*Col. lib. i. cap. 4.*)

78. *Pliny, noticing this remark of Cato's*, observes that Lucullus had thereby rendered himself liable to the chastisement of the censors, having less occasion to plough his lands than to clean his house. "In this case," says he, "to plough less than to sweep, was a foundation for the chastisement of the censors." (*Plin. Nat. Hist. lib. xviii. cap. 6.*)

79. *Proportion the expence of the building to the rent, or the profits arising from the farm.* "An edifice should be built according to the value of the farm and fortune of the master, which, immoderately undertaken, it is commonly more difficult to support than to build. The largeness of it should be so estimated, that, if any thing shall happen to destroy it, it may be rebuilt by one, or at most by two years' rent or profits of the farm in which it is placed." (*Pal. lib. i. tit. 8.*)

80. *The position of the villa, and the situation of its different parts*, are also noticed by some of these authors. "Some art," says Pliny, "is required in this. C. Marius, of a very mean family, seven times consul, placed a *villa* in the lands of Misenum, with such skill in the contrivance, that Sylla Felix said, that all others in this respect were blind, when compared to him." (*Plin. Nat. Hist. lib. xviii. cap. 7.*) All of them advise that it shall not be placed near a marsh, nor fronting a river. Pliny cites the authority of Homer for this. Varro says, that such a situation is cold in winter and unhealthful in summer; that, in such a place, there are many small insects that, though invisible, enter the body at the mouth and nostrils, and occasion diseases. (*Var. de R. R. lib. i. tit. 12.*) Palladius gives reasons of the same kind. (*Pal. lib. i. tit. 7.*) Besides this, Varro directs, that, if possible, it shall be placed at the foot of a mountain covered with woods, in such a manner as to be exposed to the most healthful winds, and to enjoy the sun in winter and the shade in summer. An east exposure, he thinks, is the best for this purpose. (*Var. de R. R. lib. i. cap. 12.*) Palladius proposes, that for the same purpose, the *villa* shall front the south-east; that the *prætorium*, or master's house, shall be a little higher than the rest of the *villa*, both to secure the foundations, and to have a more agreeable prospect. (*Pal. lib. i. tit. 8.*) It is probable that both these authors have Italy particularly in view. But Pliny extends his views further; for he says, that the *villa* in warm climates ought to front the north, in cold climates the south, and in temperate climates the east. (*Plin. Nat. Hist. lib. xviii. cap. 7.*) Columella is more particular than any of the other authors, both in giving directions as to the situation of the *villa*, and giving reasons for the situation he recommends. (*Col. lib. i. cap. 5.*)

81. *The villa is divided into three parts, the urbana, the rustica, and the fructuaria*; all the particulars of these, Columella says, ought to be properly placed with respect to each other. The *urbana* contained the apartments of the landlord; the *rustica* contained the kitchen, the houses of the labouring servants, the stables, piggeries, and poultry houses, ponds for water, dunghills, on which, says Varro, some persons place necessary conveniences for the family. (§ xii.) Adjoining the *villa rustica*, in the residence of opulent Romans, was placed the aviary, apiary, a place for dormice, a warren for hares and rabbits, a place for snails, and a large enclosure or park of fifty acres or more for retaining live deer and wild beasts taken in the chase. The *fructuaria* contained the oil and wine cellars, the places for the oil and wine presses, the corn-yards, barns, granaries, store-houses, repositories for roots and fruits, &c.

82. Both Columella and Palladius give directions *how all these parts should be situated and constructed*; but though minute, they are not so explicit as to enable any one to delineate their ground plan. The same may be said as to the directions given by these authors, and by Pliny (*Nat. Hist. lib. xviii.*), respecting the laying out of the *villa urbana*; and the apartments for summer and winter. The subject of designing villas for the opulent belongs no doubt more to architecture than to agriculture; and therefore we shall refer for details to the plans given by Castel (*fig. 10.*), and other modern authors, who have attempted to embody the descriptions of the ancient writers.

83. *Castel's general Arrangement of a Grand Roman Villa and its Environs, is as follows* :

- |  |  |                            |
|--|--|----------------------------|
| (1) Prætorium.                                   | (11) Ornithon of Varro.  | (20) Mill driven by water. |
| (2) Farm-house and offices.                      | (12) Vivarium, or park for wild beasts.  | (21) Temple of Ceres.      |
| (3) Canal, parting the farm from the prætorium.  | (13) Small woody islands for peacocks.   | (22) Corn-fields.          |
| (4) Stone-banks to the canal.                    | (14) Place for turkeys (!), rather swans, and their keepers: turkeys being natives of America, and consequently unknown to the Romans. | (23) Vineyards.            |
| (5) Bridges.                                     | (15) Forge and their keeper.   | (24) Olive grounds.        |
| (6) Museum.                                      | (16) Cochlearium.  | (25) Meadows.              |
| (7) River Vinium.                                | (17) Dormice.  | (26) Orchard.              |
| (8) Part of the island surrounded by that river. | (18) Apiary.   | (27) Garden.               |
| (9) The other river.                             | (19) Threshing floor and barn.   | (28) Osier ground.         |
| (10) Walk on the bank of that river.             |  | (29) Woods, &c.            |
|  |  | (30) Coppices.             |

84. It is remarkable that *no directions are given as to the materials of which the villa should be built*. These would, in all probability, depend on local circumstances; rammed earth, timber, brick burned, or only dried in the sun, or stone, would be taken according

to convenience. The remains of villas which have reached modern times, are chiefly of brick stuccoed over. Pliny mentions walls in Africa and Spain, called *formacii*, the

10

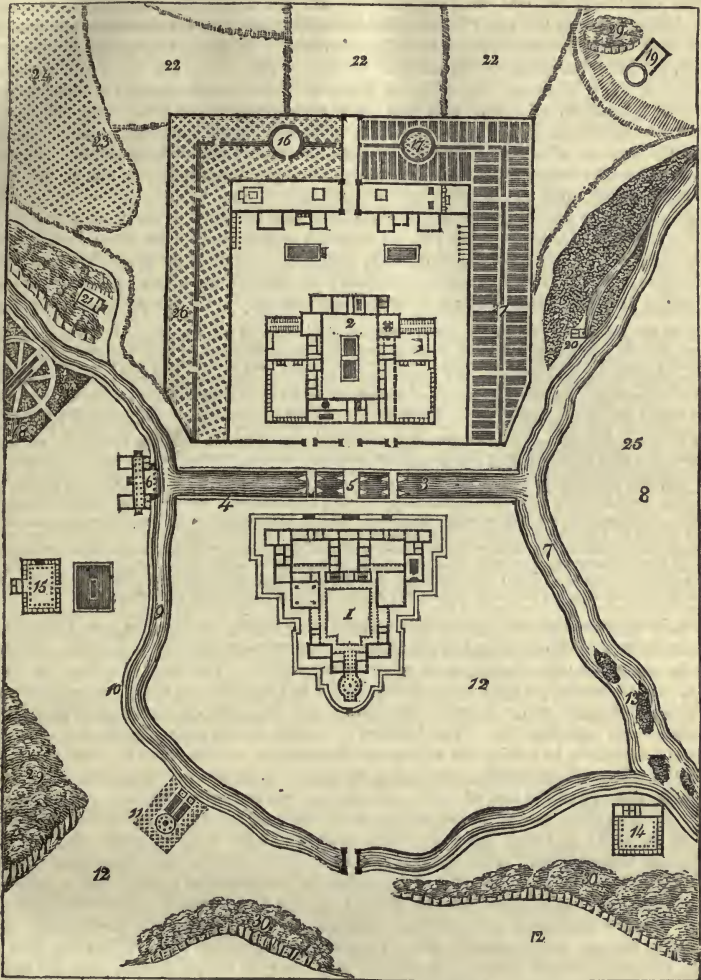

formation of which, by cramming the earth between two boards, exactly agrees with the French mode of building mud walls, called *en pise*. He also mentions walls of unburnt brick, of mud, of turf, and frames filled up with bricks and mud. (*Nat. Hist.* lib. xxxv. cap. 14.)

SUBSECT. 2. *Of the Servants employed in Roman Agriculture.*

85. *The servants employed in Roman agriculture* were of two sorts, freemen and slaves. When the proprietor or farmer lived on the farm and directed its culture, these were directly under his management; in other cases there was a bailiff or overseer, to whom all the other servants were subordinate. This was the case so early as Cato's time, who is very particular in his directions respecting the care a bailiff ought to take of the servants, the cattle, the laboring utensils, and in enacting his master's orders.

86. *The bailiff was generally a person who had received some education*, and could write and keep accounts; and it was expected that he should be careful, apt to learn, and capable to execute his master's orders with a proper attention to situations and circumstances. Columella, however, says, that "the bailiff may do his business very well, though he is illiterate." Cornelius Celsus says, that "such a bailiff will bring money to his master oftener than his book; because, being ignorant of letters, he is the less capable to

contrive accounts, and is afraid to trust another, being conscious of fraud." (*Col. lib. i. cap. 8.*) There are some other things mentioned by this author, with respect to the bailiff, that are very proper, and shew particularly the attention of the Romans. "He ought not," says he, "to trade upon his own account, nor employ his master's money in purchasing cattle or any other goods; for this trading takes off his attention, and prevents him from keeping square accounts with his master. But when he is required to settle them, he shows his goods in the place of money. This, above all, he should be careful of, not to think he knows any thing he does not know; and always be ready to learn what he is ignorant of. For as it is of great advantage to do a thing well, so it is most hurtful to have it ill done. This one thing holds true in all rustic work, to do but once what the manner of culture requires; because, when imprudence or negligence in working is to be set to rights, the time for the work is already wasted; nor are the effects of the amendment such as to make up the lost labour, and balance the advantages that might have been gained by improving the season that is past." (*Col. lib. i. cap. 8.*)

87. *The qualities of the other villa servants* are represented by the same author in this manner: "The careful and industrious," says he, "should be appointed masters of the works; these qualities are more necessary for this business than stature, or strength of body; for this service requires diligent care and art." Of the ploughman he says,

88. *In the ploughman*, though a degree of genius is necessary, yet it is not enough. "There should be joined to it a harshness of voice and manner, to terrify the cattle: but he should temper strength with clemency; because he ought to be more terrible than cruel, that so the oxen may obey his commands, and continue the longer at their work, not being spent, at the same time, both with the severity of labour and stripes. But what the offices of masters of works and of ploughmen are, I shall mention in their proper places. It is sufficient at present to observe, that tallness and strength are of great use in the one, and of very little in the other; for we should make, as I have said, the tallest man a ploughman, both for the reason I have already mentioned, and because there is no rustic work by which a tall man is less fatigued than by ploughing; because, when employed in this, walking almost upright, he may lean upon the handle of the plough." Of the common laborer he says, "The common laborer may be of any size, provided he is able to endure fatigue." And of the vine-dresser, "Vineyards do not require such tall men, provided they are thick and brawny; for this constitution of body is most proper for digging, pruning, and the other culture necessary for them. In this work diligence is less necessary than in the other works of husbandry; because the vine-dresser ought to perform his work in company and under the eye of a director. Commonly wicked men are of a quicker genius, which this kind of work requires; and, as it requires not only a stout servant, but one of an active contrivance, vineyards are commonly cultivated by slaves in chains." (*Col. lib. i. cap. 9.*) Thus we see, that, among the Romans, laborers were appointed to the different works of husbandry, according to their strength, size, and genius.

89. With respect to *the wages of agricultural labor among the Romans*, very little benefit can be derived from knowing the absolute sum of money paid for any article, unless it can be compared with the price of other commodities. The price of a slave in Cato's time, was about 50*l.*; in the time of Columella it had risen to 60*l.*; or to the price of eight acres of good land. A good vine-dresser cost 6*l.* 13*s.* 4*d.* and a good ploughman or laborer not less than 6*l.* The interest of money at this time was 6*l.* per cent. per annum; therefore, in stating the expence of farm labor, a slave must be rated at not less than 12*l.* per cent. as being a perishable commodity; so that one who cost 60*l.* would fall to be charged at the rate of 7*l.* 4*s.* per annum, besides his maintenance and clothing. This may give some idea of the wages that would be paid to a free servant who hired himself by the year; of which, however, there appears to have been no great number, their wages not being stated. Two reflections which arise from these statements may be mentioned incidentally: the first, that a much greater proportion of capital was required to carry on Roman agriculture, than in Britain or any free country where the capital of labor was not purchased, but only the interest paid as the labor is performed; and, secondly, that our farm servants, who in some places are paid from 15*l.* to 20*l.* per annum, besides food and lodging, would, if they were to be purchased, cost the farmer from 150*l.* to 200*l.* each. A farmer, therefore, who occupied three hundred acres, and employed a capital of 3000*l.* and six servants, would require an addition to his capital of at least one third, if he were obliged to purchase those servants.

90. *All the servants were maintained and clothed by the farmer or proprietor*; and as may be supposed, it was the interest of the latter that this should be done in a good and sufficient manner. Columella mentions what he calls an old maxim, concerning the bailiff: "That he should not eat but in the sight of all the servants, nor of any other thing but what was given for the rest." He mentions the reason of this: "For thus," says he, "shall he take care that both the bread be well baked, and the other things prepared in a wholesome manner." (*Col. lib. i. cap. 8.*) The same author mentions the treatment that masters ought to give their slaves: "So much the more attentive," says he, "ought the master to be in his inquiry concerning this kind of servants, that they may not be injured in their clothes and other things afforded them, inasmuch as they are subject to many, such as bailiffs, masters of works, and gaolers; and the more they are liable to receive injuries, and the more they are hurt through cruelty or avarice, the more they are to be feared. Therefore a diligent master ought to inquire, both at themselves, and likewise the free servants in whom he may put greater confidence, whether they receive the full of what is allowed them; he himself ought likewise to try, by tasting



the goodness of the bread and drink, and examining their clothes, mittens, and shoes." (*Col. lib. i. cap. 8.*) In another place, he says, "That the bailiff should have the family dressed and clothed rather usefully than nicely, and carefully fortified against the wind, cold, and rain; all which they will be secured from, by sleeved leathern coats, old *centones* (thick stuff used as bed-quilts) for defending their heads; or cloaks with hoods. If the laborers are clothed with these, no day is so stormy as to prevent them from working without doors." (*Col. lib. i. cap. 8.*) Cato likewise makes particular mention of the clothes of the slaves: "The vestments of the family," says he, "a coat and a gown three and a half feet long should be given once in two years; whenever you give a coat or a gown, first receive the old one; of these make *centones*. Good shoes should be given once in two years." (*Cat. cap. 59.*)

91. Cato informs us *what quality of bread and wine, and what other kinds of meat were given to laborers.* Of bread, he says, each laborer was allowed at the rate of three pounds avoirdupois, or of three pounds twelve ounces avoirdupois in the day, according to the severity of their labor. "During the winter," says he, "the bailiff should have four *modii* of wheat each month, and during the summer four *modii* and a half; and the housekeeper, or the bailiff's wife, and the shepherd, should have three. During the winter, the slaves should have four pounds of bread each in the day; from the time that they begin to dig the vineyard, to the ripening of the figs, they should have five pounds each; after which they should return again to four." (*Cat. cap. 56.*) To this bread, there was a daily allowance of wine; during the three months that immediately followed the vintage, the servants drank a weak kind of wine called *lora*. The manner in which this liquor was made, is described both by Pliny and Columella; and from the description given by them, it may well be supposed to be as good as the small beer given to servants in Britain. (*Plin. Nat. Hist. lib. xiv. cap. 10.*) It does not appear that the Roman slaves were much restricted in the quantity; Cato mentions no measure; he only says, that they have this to drink for three months after the vintage; he proceeds in this manner: "In the fourth month, each should get a *hemina* of wine in the day, which is at the rate of two and a half *congi* in the month; in the fifth, sixth, seventh, and eighth months, each a *sextary* in the day, which is five *congi* in the month; in the ninth, tenth, and eleventh, each three *heminae* in the day, which is an *amphora* in the month. More than this, at the *saturnalia* and *compitalia*, to each man was given a *congius*. The quantity of wine for each man in the year is eight quadrants; however, as addition must be made according to the work in which the slaves are employed, it is not too much for each of them to drink ten quadrants in the year." This allowance of wine, it must be acknowledged, was not inconsiderable, being at least seventy-four gallons in the year, or at an average 1.62 parts of a pint in the day.

92. Besides bread and wine, the slaves got what was called *pulmentarium*, which answers to what in some parts of the country is called kitchen dripping or fat. (*Plin. Nat. Hist. lib. xviii. cap. 8.*) For this purpose Cato recommends the laying up as many fallen olives as can be gathered; afterwards the early olives from which the smallest quantity of oil is expected; at the same time observing that these must be given sparingly, that they may last the longer. When the olives are finished, he desires salt fish and vinegar to be given, and besides, to each man a *sextarius* of oil in the month, and a *modius* of salt in the year. (*Cat. cap. 18.*) Columella, for this purpose, directs apples, pears, and figs, to be laid up: he adds, if there is a great quantity of these, the rustics are secured in no small part of their meat during the winter, for they serve for dripping or fat. (*Col. lib. xii. cap. 14.*)

### SUBJECT. 3. *Of the Beasts of Labor used by the Romans.*

93. The laboring cattle used by the Romans, as well as all the ancient nations, were chiefly the ox, the ass sometimes, the mule for burdens, and but very rarely the horse. The horse, however, was reared; but almost exclusively for the saddle, the chace, or for war. The respect for the ox which existed among the Egyptians, Jews, and Greeks, was continued among the Romans, so much so that Varro, and after him Columella and Pliny, adduces an instance of a man having been indicted and condemned for killing one to please a boy who longed for a dish of tripe.

94. The breeding, breaking, feeding, and working of the ox is very particularly treated of by the ancient authors.

95. Bulls, says Palladius, "should be tall, with huge members, of a middle age, rather young as old, of a stern countenance, small horns, a brawny and vast neck, and a confined belly." (*Pal. lib. iv. sect. 11.*)

96. The cows, Columella "most approves of, are of a tall make, long, with very large belly, very broad forehead, eyes black and open, horns graceful, smooth and black, hairy ears, strait jaws, very large dewlap and tail, and moderate hoofs and legs." (*Col. lib. vi. cap. 21.*)

97. Breeders both of horses and cows, Virgil observes, should attend principally to the make of the female. "If any one," says he, "fond of the prize at the olympic games, breeds horses; or if any one breeds stout bullocks for the plough, he chiefly attends to the make of the mother, who ought to be large in all her parts." (*Georg. iii. v. 49.*) The same maxim is attended to by the best breeders of the present day; and the reasons have been most satisfactorily and scientifically given by Cline. (*Commun. to Board of Ag. &c. vol. iv.*)

98. For breaking and training cattle to the yoke, Varro and Columella give very particular directions. "To break bullocks," says Varro, "put their necks between forked stakes; set up one for each bullock, and give them meat from the hand; they will become tractable in a few days: then in order that by degrees they may become accustomed to the yoke, let an unbroken one be joined with a veteran, whom he will imitate; then

let them go upon even ground without a plough; then yoked to a light plough in a sandy soil. That they may be trained for carriages, they should first be put to empty carts, and driven, if convenient, through a village or town; the habit of hearing frequent noise, and seeing a variety of objects, will soon make them fit for use." (*Var. lib. i. cap. 20.*)

99. *Training* commences with the calve state; and "calves," says Virgil, "which you intend for country labor, should be instructed while their youthful minds are tractable, and their age manageable: first bind round their necks wide wreaths of tender twigs; then, when their free necks have been accustomed to servitude, put real collars upon them; join bullocks of equal strength, and make them step together; at first let them frequently be employed in drawing along the ground wheels without any carriage upon them, so that they may print their steps only upon the top of the dust; afterwards let the beechen axle groan under the heavy load, and the pole draw the wheels joined to the weighty carriage." (*Georg. iii. v. 163.*)

100. *The food of laboring oxen* was the mast or nuts of the beech or sweet chestnut, grape stones, and husks after being pressed, hay, wheat and barley straw, bean, vetch, and lupine chaff, all parts of corn and pulse, grass, green forage, and leaves. The leaves used were those of the holm oak, ivy, elm (considered the best), the vine, the poplar, &c. The poplar leaves were mixed with the elm leaves to make them hold out, and when there was no elm leaves, then oak and fig leaves were used. (*Cat. cap. 54.*) The food preferred before all others by Columella, is good pasturage in summer, and hay and corn in winter, but he says the food and manner of feeding, differ in different countries.

101. *Oxen were worked in pairs abreast*, both in the cart and plough, and stood in the stables also in pairs, in *bubilia* or stalls formed on purpose. They were carefully matched, in order that the stronger might not wear out the weaker. They were yoked either by the horn or neck; but the latter mode was greatly preferred.

102. *Yoking by the horns*, Columella observes, "is condemned by almost all who have written on husbandry; because cattle can exert more strength from the neck and breast, than the horns; as in the one way, they press with the whole weight and bulk of their bodies; whereas in the other way, they are tormented with having their heads drawn back and turned up, and with difficulty stir the surface of the earth with a light plough." (*Col. lib. ii. cap. 11. 22.*)

103. *Oxen, when in the plough*, were not allowed to go a great way without turning; one hundred and twenty feet was the length fixed upon, and further than this, it was thought improper for them to pull hard without stopping. The Reverend A. Dickson thinks it probable, that "the breaks or plats for the different kinds of corn and pulse were laid out nearly of this length and breadth" (*Husb. of the Anc. ii. 452.*); and there appears grounds for concluding that the case was the same among the Jews and Greeks. It was thought proper that oxen in ploughing should be allowed to stop a little at the turning, and when they stopped, that the ploughman should put the yoke a little forward, that so their necks might cool. "Unless their necks are carefully and regularly cooled," says Columella, "they will soon become inflamed, and swellings and ulcers will arise." The same author directs, that "the ploughman when he has unyoked his oxen, must rub them after they are tied up, press their backs with his hands, pull up their hides, and not suffer them to stick to their bodies; for this is a disease that is very destructive to working cattle." No food must be given them till they have ceased from sweating and high breathing, and then by degrees, in portions as eaten; and afterwards they are to be led to the water, and encouraged by whistling." (*Col. lib. ii. cap. 3.*)

104. *In purchasing working oxen*, Varro directs to choose such as have "spacious horns, rather black than otherwise, a broad forehead, wide nostrils, a broad chest, and thick dewlap." (*Lib. i. cap. 20.*) All the Roman authors agree that the best color of the body is red or dark brown; that the black are hardier, but not so valuable: that the hair should be short and thick, and the whole skin very soft to the touch; the body in general very long and deep, or, as Columella and Palladius express it, compact and square. The particular parts they also describe at length in terms such as would for the most part be approved by experienced breeders of cattle; making due allowance for the difference between choice for working, and choice for fattening. They all concur in recommending farmers to rear at home what oxen they want; as those brought from a distance often disagree with the change of soil and climate.

105. *The ass was the animal next in general use.* Varro says, they were chiefly used to carry burdens, or for the mill; or for ploughing where the land is light, and that they were most common in the south of Italy, especially in Campania. (*Lib. ii. cap. 6.*) He gives directions for breeding and rearing of them: and states that the female should not be allowed to work when in an advanced state of impregnation; but that the male does not improve by indulgence in labor. The foal is removed from the dam a year after being foaled, and broke for labor in the third year.

106. *Mules*, Columella says, "are very proper both for the road and the plough, provided they are not too dear, and the stiff lands do not require the strength of the ox." "Mules and hinnis," Varro observes, "are of two kinds; the first being the offspring of a mare and an ass, and the second of a horse and an ass. A hinnus is less than an ass in the body, com-

monly of a brighter color; his ears, main, and tail like those of the horse. The mule is larger than the ass, but has more of the character of that animal in its parts than the hinnus. To breed mules, a young jack ass is put under a mare when he is foaled, and being reared with her is admitted to her the third year; nor does he despise the mare on account of former habits. If you admit him younger he soon gets old, and his offspring is less valuable. Persons who have not an ass which they have brought up under a mare, and who wish to have an ass for admission, choose the largest and the handsomest they can find, from a good breed." (*Varro*, lib. ii. cap. 8.) Mules are fed like the ass, on spray, leaves, herbage, hay, chaff, and corn.

107. *The horse was scarcely, if at all, used in Roman agriculture*, but was reared for the saddle, and the army, by some farmers. *Varro* and *Columella* are particular in their directions as to the choice of mares, and breeding and rearing their young; but as these contain nothing very remarkable, we shall pass over most of them. "When a horse," says *Varro*, "is admitted to a mare and is fastidious, they pound a squill with water to the consistence of honey, they rub the mare with it; they then apply it to the nostrils of the horse." (*Lib. ii. cap. 7.*) The same author relates a case after *Aristotle*, and which is also noticed by *Pliny*, of "a horse which could not be induced to cover his dam, and when the groom had brought him with his head covered, and compelled him to do it, when he uncovered the horse's eyes, he attacked and killed him." (*Id.*) He recommends large horses for admission, which is contrary to modern practice. The signs of future merit in a colt are a small head, well formed limbs, and contending with other colts or horses for superiority in running, or any other thing.

108. *The dog is a valuable animal in every unenclosed country*, and was kept by the Roman farmers for its use in assisting the shepherd, and also for watching. *Varro* mentions two kinds; one for hunting, which belongs to fierce and savage beasts; and one for the shepherd, and the watch box. The latter are not to be bought from hunters or butchers, because these are either lazy, or will follow a stag rather than a sheep. The best color is white, because it is most discernible in the dark. They must be fed in the kitchen with bread and milk; or broth with bruised bones, but never with animal food, and never allowed to suffer from hunger, lest they attack the flock. That they may not be wounded by other beasts, they wear a collar made of strong leather set with nails, the inward extremity of which is covered with soft leather, and that the hardness of the iron may not hurt their necks. If a wolf or any other beast is wounded by these, it makes other dogs that have not the collar remain secure. (*Var. lib. ii. cap. 9.*)

SUBJECT. 4. *Of the Agricultural Implements of the Romans.*

109. *The Romans used a great many instruments* in their culture and farm management; but their particular forms and uses are so imperfectly described, that very little is known concerning them.

110. *The plough*, the most important instrument in agriculture, is mentioned by *Cato* as of two kinds, one for strong, and the other for light soils. *Varro* mentions one with two mould boards, with which, he says, "when they plough after sowing the seed, they are said to ridge." *Pliny* mentions a plough with one mould board for the same purpose, and others with a coulter, of which, he says, there are many kinds. It is probable indeed, as the Rev. A. Dickson has remarked, that the ancients had many different kinds of ploughs, though, perhaps, not so scientifically constructed as those of modern times. "They had ploughs," he says, "with mould boards, and without mould boards; with and without coulters; with and without wheels; with broad and narrow pointed shares; and with shares not only with sharp sides and points, but also with high raised cutting tops." (*Husb. of the An. ii. 388.*) But amidst all this variety of ploughs, no one has been able to depict the simplest form of that implement in use among the Romans. Professor *John Martyn*, in his notes to *Virgil's Georgics*, gives a figure of a modern Italian plough to illustrate *Virgil's* description. *Rosier* says, the Roman plough was the same as is still used in the south of France (*fig. 11.*). Some authors have made fanciful representations of it of the

11

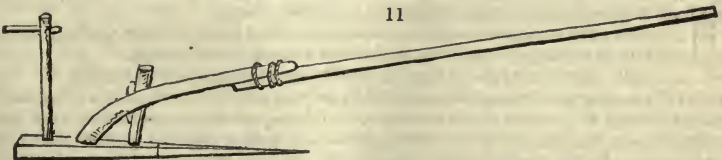

rudest construction; others have exhibited more refined pieces of mechanism, but most improbable as portraits.

111. *From the different parts of the plough* mentioned by the Roman authors, a figure has been imagined and described by the author of the *Husbandry of the*

*Ancients*, which from his practical knowledge of agriculture, and considerable classical learning, it is to be regretted he did not live to see delineated. A plough in use from time immemorial in Valentia, (*fig. 12.*) is supposed to come the nearest to the common Roman implement.

In it we have the buris or head (*a*); the temo, or beam (*b*); the stiva, or handle (*c*); the dentales, or share head (*d*); and the romer or share (*e*). The other parts, the aura or mould board, and the culler or coulter, composed no part of the simplest form of Roman plough; the plough-staff, or paddle, was a detached part; and the manicula, or part which the ploughman took hold of, was a short bar fixed across, or into the handle, and the draught pole (*f*) was that part to which the oxen were attached.

112. *The plough described by Virgil*, had a mould board, and was used for covering seed and ridging; but that which we have depicted, was the common form used in stirring the soil. To supply the place of our mould boards, this plough required either a sort of diverging stick (*g*), inserted in the share head, or to be held obliquely and sloping towards the side to which the earth was to be turned. The Romans did not plough their fields in beds, by circumvolving furrows, as we do; but the cattle returned always in the same furrow.

113. *Wheel ploughs*, Lasteyrie thinks, were invented in or not long before the time of Pliny, who attributes the invention to the inhabitants of Cisalpine Gaul. Virgil seems to have known such ploughs and refers to them in his *Georgics*. In the Greek monuments of antiquity are only four or five examples of these. Lasteyrie has given figures of three wheel ploughs from Caylus's *Collection of Antiquities* (*fig. 13. a and b*), and from a Sicilian medal (*c*).

114. *The urpex or irpex*, seems to have been a plank with several teeth used as our brake or cultivator, to break rough ground, and tear out roots and weeds.

115. *The crates* seems to have been a kind of harrow.

116. *The rastrum*, a rake used in manual labour: and

117. *The sarculum*, a hand hoe, similar to our draw hoe.

118. *The marra*, a hand hoe of smaller size.

119. *The bidens* (*bi dens*) seems to have been a two-pronged hoe of large size, and with a hammer at the other end used to break clods. These were used chiefly in cultivating vineyards.

120. *The ligo* seems to have been a spade (*fig. 14.*), and the *pala* a shovel or sort of spade, or probably a synonyme. The *ligo* and *pala* were made of wood only, of oak shod with iron, or with the blade entirely of iron.

121. *The securis* seems to have been an axe, and the same term was applied to the blade of the pruning knife, which was formed like a crescent.

122. *The dolabre* was a kind of adze for cutting roots in tree culture.

123. *The reaping hook* seems to have been the same as that in modern use: some were used for cutting off the ears of far or maize, and these, it may be presumed, were not serrated like our sickles; others for cutting wheat and barley near the ground, like our reaping hook. In the south of Gaul, Pliny informs us, they had invented a reaping machine: from his description this machine must have borne a considerable resemblance to that used in Suffolk, for cropping the heads off clover left for seed, and not unlike other modern attempts at an engine of this description. (*See fig. 16.*) This may seem truly remarkable: but man is every where, and at all times, the same animal; and the

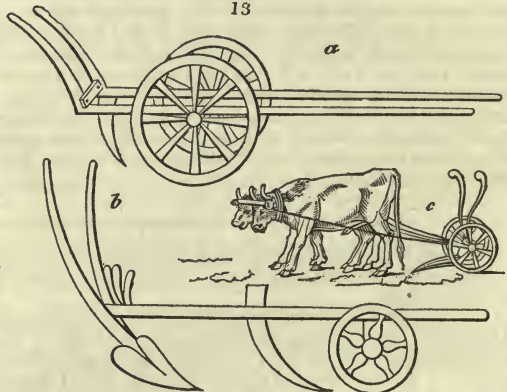
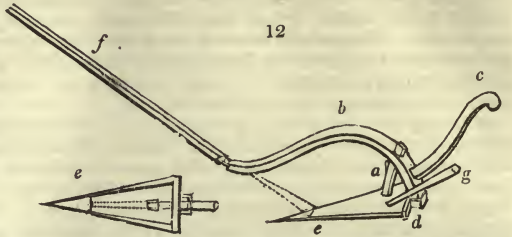

operation of similar circumstances produces in him similar results, however distant in time or place.

124. *There were threshing implements* for manual labor, and for being drawn by horses; and some for striking off the ears of corn (*fig. 15.*), like what are called rippling combs, for combing off the capsules of newly pulled flax.

125. *A variety of other instruments* for cleaning corn, and for the wine and oil press, are mentioned; but too obscurely to admit of exact description.

15

SUBJECT. 5. *Of the Agricultural Operations of the Romans.*

126. *Of simple agricultural operations*, the most important are ploughing, sowing, and reaping; and of such as are compound, or involve various simple operations, are fallowing, manuring, weeding, and field watering.

127. *Ploughing* is universally allowed to be the most important operation of agriculture. "What," says Cato, "is the best culture of land? Good ploughing. What is the second? Ploughing in the ordinary way. What is the third? Laying on manure." (*Cap. lxi.*) The season for ploughing was any time when land was not wet; in the performance, the furrow is directed to be kept equal in breadth throughout, one furrow equal to another; and straight furrows. The usual depth is not mentioned, but it was probably considerable, as Cato says corn-land should be of good quality for two feet in depth. No scamni or balks (hard unmoved soil) were to be left, and to ascertain that this was properly attended to, the farmer is directed, when inspecting the work done, to push a pole into the ploughed land in a variety of places. The plough was generally drawn by one pair of oxen, which were guided by the ploughman without the aid of a driver. In breaking up stiff land, he was expected to plough half an acre; and in free lands, an acre; and light lands, one and a half acre each day. Land, as already noticed (103.), was ploughed in square plots of 120 feet to the side, two of which made a jugerum or acre. A similar practice seems to have existed among the eastern nations, and is probably alluded to in the book of Samuel (*chap. xiv. 5. 14.*), where Jonathan and his armour-bearer are said to have slain about twenty men within half an acre, or literally "half a furrow of an acre of land."



128. *Fallowing was a universal practice among the Romans.* In most cases, a crop and a year's fallow succeeded each other; though, when manure could be got, two crops or more were taken in succession; and on certain rich soils, which Pliny describes as favorable for barley, a crop was taken every year. In fallowing, the lands were first ploughed after the crop was removed, generally in August; they were again cross-ploughed in spring, and at least a third time before sowing, whether spring corn or winter corn was the crop. There was, however, no limit to the number of ploughings and sarclings, and when occasion required manual operations; the object being, as Theophrastus observes, "to let the earth feel the cold of winter, and the sun of summer, to invert the soil, and render it free, light, and clear of weeds, so that it can most easily afford nourishment." (*Theo. de Caus. Plant. lib. iii. cap. 25.*)

129. *Manuring* was held in such high esteem by the Romans, that immortality was given to Stercutius for the invention. They collected it from every source which has been thought of by the moderns, vegetable, animal, and mineral, territorial, aquatic, and marine. Animal dung was divided into three kinds, that which is produced by birds, by men, and by cattle. Pigeon-dung was preferred to all, and next human ordure and urine. Pigeon-dung was used as a top-dressing; and human dung, mixed with cleanings of the villa, and with urine, was applied to the roots of the vine and the olive. "M. Varro," says Pliny, "extols the dung of thrushes from the avaries, as food for swine and oxen, and asserts that there is no food that fattens them more quickly." Varro prefers it also as a manure; on which Pliny observes, "we may have a good opinion of the manners of our times, if our ancestors had such large aviaries, as to procure from them dung to their fields." (*Nat. Hist. lib. xvii. cap. 9.*) Dung-hills were directed to be placed near the villa, their bottoms hollowed out to retain the moisture, and their sides and top defended from the sun by twigs and leaves. Dung usually remained in the heap a year, and was laid on in autumn and spring, the two sowing seasons. No more was to be spread than could be ploughed in the same day. Crops that were sickly were revived by sowing over them the dust of dung, especially that of birds, that is, by what is now called a top-dressing. Frequent and moderate dunnings are recommended as preferable to occasional and very abundant supplies. Green crops, especially lupines, were sown, and before they came into pod ploughed in as manures: they were also cut and buried at the roots of fruit-trees for the same purpose. Trees, twigs, stubble, &c. were burned for manure. Cato says, "If you cannot sell wood and twigs, and have no

stone that will burn into lime, make charcoal of the wood, and burn in the corn-fields the twigs and small branches that remain." Palladius says, "that lands which have been manured by ashes of trees will not require manure for five years." (Lib. i. 6.) Stubble was very generally burned, as it was also among the Jews. Lime was used as a manure, especially for vines and olives. Cato gives particular directions how to form the kiln and burn it. He prefers a truncated cone, ten feet diameter at the bottom, twenty feet high, and three feet diameter at the top. The grate covers the whole bottom; there is a pit below for the ashes, and two furnace-doors, one for drawing out the burnt stone, and the other for admitting air to the fire. The fuel used was wood or charcoal. (Cap. 38.)

130. *Marl* was known to the earlier Roman authors, but not used in Italy. It is mentioned by Pliny as having been "found out in Britain and Gaul." "It is a certain richness of earth," he says, "like the kernels in animal bodies that are increased by fatness." Marl, he says, was known to the Greeks, "for is there any thing," he adds, "that has not been tried by them? They call the marl like white clay *leucargillon*, which they use in the lands of Megara, but only where they are moist and cold." (Nat. Hist. lib. xvii. cap. 5—8.) But though the Romans did not use marl, because they had not discovered it in Italy, they were aware, as Varro and others inform us, of its use. "When I marched an army," says Varro, "to the Rhine, in transalpine Gaul, I passed through some countries where I saw the fields manured with white fossil clay." (Lib. i. cap. 7.) This must have been either marl or chalk.

131. *Sowing* was performed by hand from a basket, as in modern times; the hand, as Pliny observes, moving with the step, and always with the right foot. The corns and leguminous seeds were covered with the plough, and sometimes so as to rise in drills; the smaller seeds with the hoe and rake.

132. *In reaping corn*, it was a maxim, that it is "better to reap two days too soon than two days too late." Varro mentions three modes of performing the operation; cutting close to the ground with hooks, a handful at a time; cutting off their ears with a curved stick, and a saw attached; and cutting the stalks in the middle, leaving the lower part or stubble to be cut afterwards. Columella says, "Many cut the stalks by the middle, with drag-hooks, and these either beaked or toothed: many gather the ears with *mergas*, and others with combs. This method does very well where the crop is thin; but it is very troublesome where the corn is thick. If, in reaping with hooks, a part of the straw is cut off with the ears, it is immediately gathered into a heap, or into the nubilarium, and after being dried, by being exposed to the sun, is threshed. But if the ears only are cut off, they are carried directly to the granary, and threshed during the winter." (Col. lib. ii. cap. 21.) To these modes, Pliny adds, that of pulling up by the roots, and remarks generally that "where they cover their houses with stubble, they cut high, to preserve this of as great a length as possible; when there is a scarcity of hay, they cut low, that straw may be added to the chaff." (Nat. Hist. lib. xviii. cap. 30.)

16

133. *A reaping-machine* is mentioned both by Pliny and Palladius, used in the plains of Gaul, which is thus described by the latter. "In the plains of Gaul, they use this quick way of reaping, and, without reapers, cut large fields with an ox in one day. For this purpose a machine is made, carried upon two wheels; the square surface has boards erected at the sides, which, sloping outwards, make a wider space above; the board on the fore part is lower than the others; upon it there are a great many small teeth, wide set in a row, answering to the height of the ears of the corn, and turned upwards at the ends; on the back part of this machine, two short shafts are fixed, like the poles of a litter; to these an ox is yoked, with his head to the machine, and the yoke and traces likewise turned the contrary way: he is well trained, and does not go faster than he is driven. When this machine is pushed through the standing corn, all the ears are comprehended by the teeth, and heaped up in the hollow part of it, being cut off from the straw, which is left behind; the driver setting it higher or lower, as he finds it necessary; and thus, by a few goings and returnings, the whole field is reaped. This machine does very well in plain and smooth fields, and in places where there is no necessity for feeding with straw." (Pal. lib. vii. tit. 2.) A conjectural delineation of this machine (fig. 16.) is given by Lesteyrie, in his *Collection des Machines*, &c.



134. *The Romans did not bind their corn into sheaves*, as is customary in northern climates. When cut it was in general sent directly to the area to be threshed; or if the ears only were cropped, sent in baskets to the barn. Among the Jews, Egyptians, and Greeks, the corn was bound in sheaves; or at least some kinds were so treated, as appears from the story of Ruth "gleaning among the sheaves;" of Joseph's dream, in which his "sheaf arose;" and from the harvest represented by Homer, on one of the

compartments of Achilles's shield. (*Il. lib. xviii. 550.*) Reapers were set in bands on the opposite side of the field or plat, and worked towards the centre. As the land was ploughed in the same manner from the sides to the middle, there was an open furrow left there, to which the reapers hastened in the way of competition. A reaper was expected to cut down a jugerum of wheat in a day and a half; barley, legumes, and medica or clover, in one day, and flax in three days.

135. *Threshing was performed in the area or threshing floor*, a circular space of 40 to 60 feet in diameter, in the open air, with a smooth hard surface. The floor was generally made of well wrought clay mixed with *amurca* or the lees of oil; sometimes it was paved. It was generally placed near the *nubilarium* or barn, in order that when a sudden shower happened, during the process of threshing, the ears might be carried in there out of the rain. Sometimes also the ears or unthreshed corn of the whole farm were first put in this barn and carried out to the area afterwards. Varro and Columella recommended that the situation of the area should be high and airy, and within sight of the farmer or bailiff's house, to prevent fraud; distant from gardens and orchards, because, though dung and straw are beneficial to the roots of vegetables, they are destructive when they fall on their leaves." (*Var. lib. i. cap. 51.*)

136. *The corn being spread over the area a foot or two in thickness, was threshed or beaten out by the hoofs of cattle, or horses driven round it, by their dragging a machine.* The machine, Varro informs us, was "made of a board, rough with stones or iron, with a driver or great weight placed on it." A machine composed of rollers studded with iron knobs, and furnished with a seat for the driver, (*fig. 17.*) was used in the Carthaginian territory. Sometimes also they threshed with rods or flails: far or Indian corn, (*Zea Mays, L.*) was generally hand picked, or passed through a handmill.

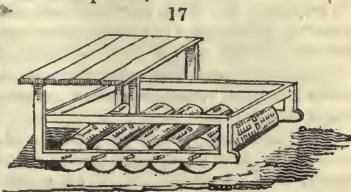

137. *Corn was cleansed or winnowed by throwing it from one part of the floor to another, (in the wind when there was any,) with a kind of shovel called ventilarium; another implement, called a van, probably a kind of sieve, was used when there was no wind.* After being dressed, the corn was laid in the granary, and the straw either laid aside for litter, or, what is not a little remarkable, "sprinkled with brine; then, when dried, rolled up in bundles, and so given to the oxen for hay." (*Plin. Nat. Hist. lib. xviii. cap. 30.*)

138. *Hay-making among the Romans was performed much in the same way as in modern times.* The meadows were mown when the flowers of the grass began to fade; "as it dries," says Varro, "it is turned with forks; it is then tied up in bundles of four pounds each, and carried home, and what is left strewed upon the meadow is raked together, and added to the crop." "A good mower," Columella informs us, "cuts a jugerum of meadow, and binds twelve hundred bundles of hay." It is probable that this quantity, which is nearly two tons, was the produce per acre of a good crop. A second crop was cut, called *cordum*, and was chiefly used for feeding sheep in winter. Hay was also made of leafy twigs for the same purpose. Cato directs the bailiff to "cut down poplar, elm, and oak spray, and put them up in time, not over dry, for fodder to the sheep." (*Cap. 5.*)

139. *Weeding and stirring the soil were performed, the first by cutting with a hook, or pulling the weeds up with the hand; and the second by sarcling or hoeing.* Beans were hoed three times, and corn twice; the first time they were earthed up, but not the second or third; "for," says Columella, "when the corn ceases to tiller, it rots if covered with earth." Lupines were not sarclad at all, "because so far from being infested with weeds, they destroy them." Horse hoeing was also practised, the origin of which is thus given by Pliny. "We must not omit," says he, "a particular method of ploughing, at this time practised in Italy beyond the Po, and introduced by the injuries of war. The Salassi, when they ravaged the lands lying under the Alps, tried likewise to destroy the panic and millet that had just come above ground: finding that the situation of the crop prevented them from destroying it in the ordinary way, they ploughed the fields; but the crop at harvest being double of what it used to be, taught the farmer to plough amongst the corn." This operation, he informs us, was performed, either when the stalk was beginning to appear, or when the plant had put forth two or three leaves. The corn being generally sown in drills, or covered with the plough, so as to come up in rows, readily admitted this practice.

140. *Pasturing and harrowing corn, when too luxuriant, were practised.* Virgil says, "What commendation shall I give to him, who, lest his corn should lodge, pastures it while young, as soon as the blade equals the furrow." (*Geor. i. l. 111.*) Pliny directs to comb the corn with a harrow before it is pastured, and sarclad it afterwards.

141. *Watering on a large scale was applied both to arable and grass lands.* Virgil advises to "bring down the waters of a river upon the sown corn, and when the field is parched, and the plants drying, convey it from the brow of a hill in channels." (*Geor. i. l. 106.*) Pliny mentions the practice, and observes that the water destroys the weeds, nourishes

the corn, and serves in place of sarcling. Watering grass lands was practised wherever an opportunity offered. "As much as in your power," says Cato, "make watered meadows." Land that is naturally rich and in good heart, says Columella, "does not need to have water set over it, because the hay produced in a juicy soil is better than that excited by water; when the poverty of the soil requires it, however, water may be set over it. The same author likewise describes very particularly the position of the land most proper for water meadows. "Neither a low field," says he, "with hollows, nor a field broken with steep rising grounds, are proper. The first because it contains too long the water collected in the hollows; the last, because it makes the water to run too quickly over it. A field, however, that has a moderate descent, may be made a meadow, whether it is rich or poor, if so situated as to be watered. But the best situation is, where the surface is smooth, and the descent so gentle, as to prevent either showers, or the rivers that overflow it, from remaining long; and, on the other hand, to allow the water that comes over it gently to glide off. Therefore, if in any part of a field intended for a meadow, a pool of water should stand, it must be let off by drains; for the loss is equal, either from too much water or too little grass." (*Col. lib. ii. cap. 17.*)

142. *Old water meadows were renewed by breaking up and sowing them with corn for three years; the third year they were laid down with vetches and grass seeds, and then watered again, but "not with a great force of water, till the ground had become firm and bound together with turf."* (*Col. lib. ii. cap. 18.*) Watering, Pliny informs us, was commenced immediately after the equinox, and restrained when the grass sent up flower stalks; it was recommenced in mowing grounds, after the hay season, and in pasture lands at intervals.

143. *Draining*, though an operation of an opposite nature to watering, is yet essential to its success. It was particularly attended to by the Romans, both to remove surface water, and to intercept and carry off under the surface the water of springs. Cato gives directions for opening the furrows of sown fields, and clearing them so as the water might find its way readily to the ditches; and for wet-bottomed lands he directs to make drains three feet broad at top, four feet deep, and one and a quarter feet wide at the bottom; to lay them with stones; or if these cannot be got, with willow rods, placed contrary ways, or twigs tied together. (*Cap. 43.*) Columella directs both open and covered drains to be made sloping at the sides, and in addition to what Cato says respecting the water way of covered drains, directs to make the bottom narrow, and fit a rope made of twigs to it, pressing the rope firmly down, and putting some leaves or pine branches over it before throwing in the earth. Pliny says, the ropes may be made of straw, and that flint or gravel may be used to form the water-way, filling the excavation half full, or to within eighteen inches of the top.

144. *Fencing* was performed by the Romans, but only to a limited extent. Varro says, "the limits of a farm should be fenced (rendered obvious) by planting trees, that families may not quarrel with their neighbours, and that the limits may not want the decision of a judge." (*Lib. i. 15.*) Palladius directs to enclose meadows, and gardens, and orchards. Columella mentions folds for enclosing the cattle in the night-time; but the chief fences of his time were the enclosures called parks for reserving wild beasts, and forming agreeable prospects from the villas of the wealthy. Pliny mentions these, and says they were the invention of Fulvius Lupinus. (*Nat. Hist. lib. viii.*) Varro describes fences raised by planting briars or thorns, and training them into a hedge, and these, he says, have the advantage of not being in danger from the burning torch of the wanton passenger; fences of stalks interwoven with twigs, ditches with earthen dykes and walls of stone or brick, or rammed earth and gravel. (*Lib. i. cap. 14.*)

145. *Trees* were pruned and felled at different times according to the object in view. The olive was little cut; the vine had a winter dressing and one or two summer dressings. Green branches or spray, of which the leaves were used as food for oxen and sheep, were cut at the end of summer. Copse wood for fuel in winter, and timber trees generally in that season. Cato, however, directs that trees which are to be felled for timber should be cut down at different times according to their natures; such as ripen seeds, when the seed is ripe; such as do not produce seeds, when the leaves drop; such as produce both flowers and seeds at the same time, also when the leaves drop, but if they are evergreens, such as the cypress and pine, they may be felled at any time.

146. *Fruits were gathered by hand.* The ripest grapes were cut first; such as were selected for eating were carried home and hung up; and those for the press were put in baskets and carried to the wine-press to be picked and then pressed. Olives were plucked by hand, and some selected for eating; and the rest laid up in lofts for future bruising, or they were immediately pressed. Such as could not be reached by ladders, Varro directs to be "struck with a reed rather than with a rod, for a deep wound requires a physician." It does not appear that green olives were pickled and used as food as in modern times.

147. *Such are the chief agricultural operations of the Romans, of which it cannot fail to be observed as most remarkable, that they differ little from what we know of the rural*



operations of the Jews and Greeks on the one hand, and from the practices of modern times on the other.

SUBJECT. 6. *Of the Crops cultivated, and Animals reared by the Romans.*

148. *The cereal grasses* cultivated by the Romans were chiefly the *triticum* or wheat, the *far*, or Indian corn (*Zea*), and the *hordeum* or barley: but they sowed also the *siligo* or rye, the *holcus* or millet, the panic grass (*Panicum miliaceum*), and the *avena* or oat.

149. *Of legumes* they cultivated the *fabia* or bean, the *pisum* or pea, the *lupinus* or lupin, the *erum* or tare, the *lens* or flat-tare (*Lathyrus cicera*); the chickling vetch (*Lathyrus sativus*); the chick or mouse pea (*Cicer arietinum*); and the kidney bean (*Phaseolus*). The bean was used as food for the servants or slaves; the others were grown principally for food to the laboring cattle.

150. *The sesamum*, or oily grain (*Sesamum Orientale*, L.) (fig. 18.) was cultivated for the seeds from which an oil was expressed, and used as a substitute for that of olives, as it still is in India and China; and as the oil of the poppy is in Holland, that of the walnut in Savoy, and of the hemp in Russia.



18

151. *The herbage plants* were chiefly the *trifolium* or clover, the medic or lucern, and the *cytissus*. What the latter plant is, has not been distinctly ascertained. They cultivated also the *ocymum* and *faenum græcum*, with several others, which from the descriptions left of them cannot now be identified. The *napus* or turnip, and *rapa* or rape, were much esteemed and carefully cultivated. Pliny says, "they require a dry soil; that the rapa will grow almost any where; that it is nourished by mists, hoar-frosts and cold, and that he has seen some of them upwards of forty pounds weight. The napus," he says, "delights equally in colds, which make it both sweeter and larger, while by heat they grow to leaves." He adds, "the more diligent husbandmen plough five times for the napus, four times for the rapa, and apply dung to both." (*Nat. Hist.* xviii. cap. 13.) Palladius recommends soot and oil as a remedy against flies and snails, in the culture of the napus and rapa. While the turnips were growing, it appears persons were not much restricted from pulling them. Columella observes, that in his time, the more religious husbandmen still observed an ancient custom, mentioned by Varro as being recorded by Demetrius, a Greek. This was, that while sowing them they prayed they might grow both for themselves and neighbours. Pliny says the sower was naked.

152. *Of crops used in the arts* may be mentioned the flax, the sesamum, already mentioned, and the poppy; the two latter were grown for their seeds, which were bruised for oil.

153. *The ligneous crops* were willows, both for basketmaking, and as ties and poles for olives and vines. Cope wood was grown in some places for fuel; but chiefly in natural woods, which were periodically cut. Timber was also procured from the natural forests, which were abundant both of oak, elm, beech, pine, and larix.

154. *The fruit trees* cultivated extensively, were the vine and the olive. The fig was grown in gardens and orchards, and also the pear; and in the gardens of the wealthy were found most fruits in present use, with the exception of the pine apple, the gooseberry, and perhaps the orange, though the lemon seems to have been known in Palladius' time. The vine was supported by elms or poplars (fig. 19.), or tied to different sorts of trellises (fig. 20.), as in Italy at the present day.



19

155. *Such are the principal field crops of Roman agriculture* from which, and from the list of cultivated vegetables given by Pliny, it appears they had most plants and trees now in use, with the exception of the potatoe, and one or two others of less consequence.

156. *Of animals reared*, the quadrupeds were of the same kinds now in use; and to the common sorts of poultry they added thrushes, larks, peacocks, and turtle doves; they also reared snails, dormice, bees, and fish. The care of the poultry was chiefly committed to the wife of the farmer or bailiff; and it was chiefly near Rome and Naples where the more delicate birds were extensively reared.

When Rome was at her greatest height in the time of the Cesars, the minor articles of farm produce bore a very high price. Varro informs us, that "fat birds, such as thrushes, black-birds, &c., were sold at two shillings, and sometimes 5000 of them were sold in a year from one farm. (*Var. lib. iii. cap. 2.*) Pea-fowls were sold at 1l. 13s. 4d.; an egg was sold at 3s. 4d. A farm sometimes produced as many of these



20

fowls as to sell at 500*l.* (*Var. lib. iii. cap. 6.*) A pair of fine doves were commonly of the same price with a peacock, 1*l.* 13*s.* 4*d.* If very pretty, they were much higher in the price, no less than 8*l.* 6*s.* 8*d.* L. Anius, a Roman knight, refused to sell a pair under 13*l.* 6*s.* 8*d.*" (*Var. lib. iii. cap. 7.*) Some kinds of fishes were very highly valued among the Romans in the time of Varro. Hortensius, whom Varro used frequently to visit, would sooner have parted with a pair of his best coach-mules, than with a bearded mullet. (*Var. lib. iii. cap. 17.*) Herrius's fish-ponds, on account of the quantity of fish, were sold for 33,333*l.* 6*s.* 8*d.* (*Plin. Nat. Hist. lib. ix. cap. 55.*) Lucullus's likewise at the same price. (*Id. lib. ix. cap. 54.*)

SUBJECT. 7. *Of the General Maxims of Farm Management among the Romans.*

157. *In every art that has been long practised, there are maxims of management which have been handed down from one generation to another; and in no art are there more of these than in agriculture.* Maxims of this sort were held among the Romans in the greatest estimation, and their writers have recorded a number derived from the lost Greek writers, and from their own traditional or experimental knowledge. A few of these shall be noticed, as characteristic of Roman economy, and not without their use in modern times.

158. *To sow less and plough better* was a maxim indicating that the extent of farms ought to be kept in their proper bounds. Pliny and Virgil consider large farms as prejudicial, and Columella says, one of the seven wise men has pronounced that there should be limits and measures in all things. "You may admire a large farm, but cultivate a small one;" and the Carthaginian saying, "that the land ought to be weaker than the husbandman," were maxims to the same effect.

159. *The importance of the master's presence* in every operation of farming was inculcated by many maxims: "Whoever would buy a field ought to sell his house, lest he delight more in the town than in the country," was a saying of Mago. "Wherever the eyes of the master most frequently approach," says Columella, "there is the greatest increase." It is justly remarked by the Rev. A. Dickson, that though "every person knows that the presence and attention of the master is of great importance in every business; yet every person does not know, that in no business are they so important as in farming." (*Hist. of the An. i. 206.*)

160. *That more is to be gained by cultivating a small spot well than a large space indifferently,* is illustrated by many sayings and stories. "A vine-dresser had two daughters and a vineyard; when his eldest daughter was married, he gave her a third of his vineyard for a portion; notwithstanding which, he had the same quantity of fruit as formerly. When his younger daughter was married he gave her the half of what remained, and still the produce of his vineyard was not diminished." (*Col. lib. iv. cap. 3.*) Pliny mentions a freedman, who having much larger crops than his neighbours, was accused of witchcraft and brought to trial. He produced in the forum a stout daughter, and his excellently constructed iron spades, shears, and other tools, with his oxen, and said, "These, Romans, are my charms." He was acquitted. (*Nat. Hist. xviii. 6.*)

161. *Ostentatious or profuse culture* is not less condemned than imperfect culture. "The ancients," says Pliny, "assert that nothing turns to less account than to give land a great deal of culture." "To cultivate well is necessary, to cultivate in an extraordinary manner is hurtful." "In what manner then," he asks, "are lands to be cultivated to the best advantage?" To this he answers, "In the cheapest manner if it is good;" or "by good bad things," which, he says, were the words the ancients used to express this maxim.

162. *Industry* is recommended by numerous maxims. "The ancients," says Pliny, "considered him a bad husbandman who buys what his farm can produce to him: a bad master of a family, who does in the day-time what he may do at night, except in the time of a storm: a worse, who does on common days what is lawful on holidays: the worst of all, who on a good day is employed more within doors than in the fields." (*Nat. Hist. xviii. 6.*)

163. *Kindness and humanity to servants and slaves* is strongly recommended. "Slaves," says Varro, "must not be timid nor petulant. They who preside must have some degree of learning and education; they must be frugal, older than the workmen, for the latter are more attentive to the directions of these, than they are to those of younger men. Besides, it must be most eligible that they should preside, who are experienced in agriculture; for they ought not only to give orders, but to work, that they may imitate him, and that they may consider that he presides over them with reason, because he is superior in knowledge and experience: nor is he to be suffered to be so imperious to use coercion with stripes, rather than words, if this can be done. Nor are many to be procured of the same country, for domestic animosities very often arise from this source. You must encourage them who preside, by rewarding them, and you must endeavour to let them have some privilege, and maid servants wedded to them, by whom they may have a family;

for by these means they become more steady and more attached to the farm. On account of these connections, the epirotic families are so distinguished and attached. To give the persons who preside, some degree of pleasure, you must hold them in some estimation; and you must consult with some of the superior workmen concerning the work that is to be done: when you behave thus, they think that they are less despicable, and that they are held in some degree of esteem by their master. They become more eager for work by liberal treatment, by giving them victuals, or a large garment, or by granting them some recreation or favor, as the privilege of feeding something on the farm, or some such thing. In relation to them, who are commanded to do work of greater drudgery, or who are punished, let somebody restore their good will and affection to their master by affording them the benefit of consolation.

164. *Knowledge in matters relative to agriculture* is inculcated by all the rustic authors. "Whoever," says Columella, "would be perfect in this science, must be well acquainted with the qualities of soils and plants; must not be ignorant of the various climates, that so he may know what is agreeable, and what is repugnant to each; he must know exactly the succession of the seasons, and the nature of each, lest, beginning his work when showers and wind are just at hand, his labor shall be lost. He must be capable to observe exactly the present temper of the sky and seasons; for these are not always regular, nor in every year does the summer and winter bring the same kind of weather, nor is the spring always rainy, and the autumn wet. To know these things before they happen, without a very good capacity, and the greatest care to acquire knowledge, is, in my opinion, in the power of no man." (*Col. lib. i. præf.*) To these things mentioned by Columella, Virgil adds several others. "Before we plough a field to which we are strangers," says he, "we must be careful to attain a knowledge of the winds, from what points they blow at the particular seasons, and when and from whence they are most violent; the nature of the climate, which in different places is very different; the customs of our forefathers; the customs of the country; the qualities of the different soils; and what are the crops that each country and climate produces and rejects." (*Virg. Georg. i. l. 1.*)

165. *The making experiments* is a thing very strongly recommended to the farmer by some of our authors. "Nature," says Varro, "has pointed out to us two paths, which lead to the knowledge of agriculture, viz. experience and imitation. The ancient husbandmen, by making experiments, have established many maxims. Their posterity, for the most part, imitate them; we ought to do both, imitate others and make experiments ourselves, not directed by chance, but reason." (*Var. lib. i. cap. 18.*)

#### SECT. V. *Of the Produce and Profit of Roman Agriculture.*

166. *The topics of produce and profits in agriculture, are very difficult to be discussed satisfactorily.* In manufactures the raw material is purchased for a sum certain, and the manipulation given by the manufacturer can be accurately calculated; but in farming, though the rent of the land and price of seed-corn, which may be considered the raw materials, is known; yet the quantity of labor required to bring forth the produce, depends so much on seasons, accidents, and other circumstances, to which agriculture is more liable than any other art, that its value or cost price cannot easily be determined. It is a common mode to estimate the profits of farming by the numerical returns of the seed sown. But this is a most fallacious ground of judgment, since the quantity of seed given to lands of different qualities, and of different conditions, is very different; and the acre, which, being highly cultivated and sown with only a bushel of seed, returns forty for one, may yield no more profit than that which being in middling condition requires four bushels of seed, and yields only ten for one.

167. *The returns of seed sown* mentioned by the ancients, are very remarkable. We have noticed Isaac's sowing and reaping at Gerar, (7.) where he received a hundred for one. In Mark's gospel, "good seed sown upon good ground, is said to bring forth in some places thirty, in others forty, in others sixty, and in others even a hundred fold." (Mark iv. 8.) A hundred fold, Varro informs us, was reaped about Garada in Syria, and Byzacium in Africa. Pliny adds, that from the last place, there were sent to Augustus by his factor nearly 400 stalks, all from one grain; and to Nero, 340 stalks. He says, he has seen the soil of this field, "which when dry the stoutest oxen cannot plough; but after rain I have seen it opened up by a share, drawn by a wretched ass on the one side, and an old woman on the other." (*Nat. Hist. xviii. cap. 5.*) The returns in Italy were much less extraordinary. Varro says, there are sown on a jugerum, four modii (pecks) of beans, five of wheat, six of barley, and ten of far (maize); more or less as the soil is rich or poor. The produce is in some places ten after one, but in others, as in Tuscany, fifteen after one." (*Lib. i. cap. 44.*) This, in round numbers, is at the rate of twenty-one and thirty-two bushels an English acre. On the excellent lands of Leontinum in Sicily, the produce, according to Cicero, was no more than from eight to ten for one. In Columella's time, when agriculture had declined, it was still less.

168. *The farmer's profit* cannot be correctly ascertained; but, according to a calculation made by the Rev. A. Dickson, the surplus produce of good land in the time of Varro, was about fifteen pecks of wheat per acre; and in the time of Columella, lands being worse cultivated, it did not exceed three and one-third pecks per acre. What proportion of this went to the landlord cannot be ascertained. Corn, in Varro's time, was from 4*d.* to 5½*d.* per peck: seventy years afterwards, in the time of Columella, it had risen to 1*s.* 9*d.* per peck. Vineyards were so neglected in the time of this author, that they did not yield more to the landlord as rent, than 14*s.* or 15*s.* per acre.

169. *The price of land*, in the time of Columella and Pliny, was twenty-five years' purchase. It was common, both these writers inform us, to receive 4 per cent. for capital so invested. The interest of money was then 6 per cent.; but this 6 per cent. was not what we would call legal interest; money among the Romans being left to find its value, like other commodities, of course the interest was always fluctuating.—Such is the essence of what is known as to the produce, rent, and price of lands among the Romans.

SECT. VI. *Of the Roman Agriculturists, in respect to general Science, and the Advancement of the Art.*

170. *The sciences cultivated by the Greeks and Romans were chiefly of the mental and mathematical kind.* They knew nothing of chemistry or physiology, and very little of other branches of natural philosophy; and hence their progress in the practical arts was entirely the result of observation, experience, or accident. In none of their agricultural writers is there any attempt made to give the *rationale* of the practices described; absolute directions are either given, as is frequently the case in Virgil and Columella; or the historical relation is adopted, and the reader is informed what is done by certain persons, or in certain places; as is generally the case with Varro and Pliny.

171. *Wherever the phenomena of nature are not accounted for scientifically, recourse is had to supernatural causes;* and the idea of this kind of agency once admitted, there is no limit that can be set to its influence over the mind. In the early and ignorant ages good and evil spirits were supposed to take a concern in every thing; and hence the endless and absurd superstitions of the Egyptians, some of which have been already noticed, and the equally numerous though perhaps less absurd rites and ceremonies of the Greeks, to procure their favor, or avert their evil influence. Hesiod considered it of not less importance to describe what works were to be done, than to describe the lucky and unlucky days for their performance. Homer, Aristotle, Theophrastus, and all the Greek authors, are more or less tinctured with this religion, or superstition as we are pleased to call it, of their age.

172. *As the Romans made few advances in science, consequently they made equally few in divesting themselves of the superstitions of their ancestors.* These, as most readers know, entered into every action and art of that people, and into none more than agriculture. In some cases it is of importance for the general reader to be aware of this, before perusing their rustic authors; as in the case of heterogeneous grafting, and the spontaneous generation and transmutation of plants, which, though stated by Virgil and Pliny, and others, as facts, are known to every physiologist to be impossible; but other relations are too gross to be entertained as truths by any one. Of these we may mention the lunar days, the impregnation of animals by particular winds, &c. It is impossible not heartily to concur with Lord Kaimes in congratulating the present age in the delivery from such "heavy fetters." It is curious to observe the religious economy of Cato: after recommending the master of the family to be regular in performing his devotions, he expressly forbids the rest of the family to perform any, either by themselves or others, telling them that they were to consider that the master performed sufficient devotions for the family. (*Cat. cap. 43.*) This was probably intended not only to save time, but also to prevent such slaves as had naturally more susceptible imaginations than the others, from becoming religious enthusiasts.

173. *What degree of improvement agriculture received from the Romans, is a question we have no means of answering.* Agriculture appears obviously to have declined from the time of Cato and Varro to Pliny; and therefore any improvement it received must have taken place antecedently to their era. As these authors, however, generally refer to the Greeks as their masters in this art, it appears very doubtful whether they did any thing more than imitate their practice. As a more luxurious people, they introduced new fruits, and probably improved the treatment of birds, and other minor products; but these belong more to gardening and domestic economy, than to field cultivation. In the culture of corn, herbage, plants, and fruit-trees, and in the breeding and rearing of cattle, Noah and his sons, the Jews, the Babylonians, Egyptians, and Greeks, may have been as far advanced as the Romans, for any thing that appears to the contrary. The great agricultural advantages which mankind have derived from the Romans, is the diffusion of the art by their almost universal conquests.

SECT. VII. *Of the Extent to which Agriculture was carried in the Roman Provinces, and of its Decline.*

174. *The art of agriculture was not only familiar to, but held in estimation by every Roman soldier.* It was practised by him in every foreign country where he was stationary; and taught to the inhabitants of such as were uncultivated. In some countries, as in Carthagina, great part of Spain, and a part of the south-east of France, agriculture was as far advanced as in Italy; because at Carthage and Marseilles, the Greeks had planted colonies, who flourished anterior to the Romans, or at least long before they extended their conquests to these countries: but in Helvetia, Germany, and Britain, it was in a very rude state or unknown.

175. *In Germany,* excepting on the borders of the Rhine, agriculture was never generally practised. The greater part of the country was covered with forests; and hunting and pasturage were the chief occupations of the people when not engaged in war. The decline of the Roman power in that country, therefore, could make very little difference as to its agriculture.

176. *In Britain,* according to Cæsar, agriculture was introduced by colonies from Belgium, which took shelter there from the encroachments of the Belgæ from Germany, about B. C. 150. These colonies began to cultivate the sea coasts; but the natives of the inland parts lived on roots, berries, flesh, and milk. It appears from Dio Niceus, that they never tasted fish, though, in Ossian's time, they were acquainted with catching birds with hawks trained for that purpose. Pliny mentions the use of marl as being known to the Britons; and Diodorus Siculus describes their method of preserving corn, by laying it up in the ear in caves or granaries.

177. *But the general spread of agriculture in Britain was no doubt effected by the Romans.* The tribute of a certain quantity of corn, which they imposed on every part of the country, as it fell under their dominion, obliged the inhabitants to practise tillage; and from the example of the conquerors, and the richness of the soil, they soon not only produced a sufficient quantity of corn for their own use and that of the Roman troops, but afforded every year a very great surplus for exportation. The emperor Julian, in the fourth century, built granaries to receive this corn, and on one occasion sent a fleet of eight hundred ships, "larger than common barks," to convey it to the mouth of the Rhine, where it was sent up the country for the support of the plundered inhabitants.

178. *Agriculture among the Romans themselves had begun to decline in Varro's time,* and was at a low ebb in the days of Pliny. Many of the great men of Rome, trusting to their revenues from the provinces, neglected the culture of their estates in Italy; others, in want of money to answer the demands of luxury, raised all they could upon credit or mortgage, and raised the rents of their tenants to an oppressive height to enable them to pay the interest. The farmer was in this manner deprived of his capital; his spirits were broken, and he ceased to exert himself, or became idle and rapacious like his landlord. The civil wars in the end of the second century; the tyrannic conduct of the emperors in the third; the removal of the seat of empire to Constantinople in the middle of that which followed; prepared the way for the entrance of the Goths in the beginning of the fifth century, which completed the downfall of agriculture and every peaceful art. It declined at the same time in all the western provinces: in Africa, and Spain, by the incursions of the Moors; in France, from the inroads of the Germans; in Germany and Helvetia, from the inhabitants leaving their country and preferring a predatory life in other states; and in Britain, from the invasion of the Saxons, and the inroads of the Scots and Picts.

---

CHAP. III.

*History of Agriculture during the Middle Ages, or from the Fifth to the Seventeenth Century.*

179. *In the ages of anarchy and barbarism which succeeded the fall of the Roman power in Europe,* agriculture appears to have been abandoned, or at least extremely neglected. Pasturage, in troublesome times, is always preferred to tillage, because sheep or cattle may be concealed from, or driven away on the approach of an enemy; but who would sow without a certainty of being able to reap? Happily, the weaknesses of mankind sometimes serve to mitigate the effects of their vices. Thus, the credulity of the barbarians of these times led them to respect the religious establishments, and in these were preserved such remains of letters and of arts as had escaped from utter destruction. These institutions were at first very limited, both in their buildings and possessions, and the inhabitants frugal and virtuous in their habits; but in a very few years, by the grants of the rich warriors, they acquired extensive possessions; erected the most magnificent

buildings, and lived in abundance and luxury. Their lands were cultivated by servants, under the direction of the priests, who would have recourse for information to the Roman agricultural writers, which, in common with such other books as then existed, were almost exclusively to be found in their libraries. We know little of the progress of agriculture under these circumstances for nearly ten centuries, when it began to revive throughout Europe among the lay proprietors. We shall notice some particulars relative to this revival, first in Italy, and next in Germany, France, and England. So little is known of the husbandry of Spain and the Netherlands during this period, that we shall defer what we have to say of those countries till we treat of their modern state.

SECT. I. *History of Agriculture in Italy during the Middle Ages.*

180. *Little is known of the agriculture of Italy from the time of Pliny till that of Crescenzio, a senator of Bologna, whose work In Commodium Ruralium, written in 1300, was first printed at Florence in 1478. He was soon followed by several of his countrymen, among whom Tatti, Stefano, Augustino Gallo, Sansovino, Lauro, and Torello deserve to be mentioned with honor. From some records, however, it appears that irrigation had been practised in Italy previously to 1037. The monks of Chiarevalle had formed extensive works of this kind, and had become so celebrated as to be consulted and employed as hydraulic engineers by the Emperor Frederic I. in the thirteenth century. Silk worms were imported from Greece into Sicily by Roger, the first king of that island, in 1146; but they did not extend to the continental states for many years afterwards.*

181. *In the early part of the fourteenth century, the inhabitants of the south of Italy were strangers to many of the conveniences of life; they were ignorant of the proper cultivation of the vine, and the common people were just beginning to wear shirts. The Florentines at that time were the only people of Italy who traded with England and France. The work of Crescenzio is obviously a compilation from the Roman authors, and therefore cannot be considered as giving an account of the agriculture of his time; but an edition published at Basil in 1548, and illustrated with figures, may probably be considered as indicating the implements then in use. The plough is drawn by only one ox: but different kinds to be drawn by two and four oxen are described in the text. A driver is also mentioned, which shows that the ploughmen of those days were less expert than during the time of the Romans, who used none. A waggon is described with a wooden axle and low wooden wheels; each wheel formed either out of one piece or of four pieces joined together. Knives, scythes (fig. 21.), and other grafting tools, as well as the mode of performing the operation, are figured. Sowing was then performed exactly as it was among the Romans, and is still in most parts of Europe, where a sowing machine is not employed. The various hand tools for stirring and turning the soil are described and exhibited; and the Roman bidens shown as in use for cultivating the vine. All the agricultural and horticultural plants described by Pliny are treated of, but no others.*



182. *Towards the end of the sixteenth century, Tarello's Ricordo d'Agricoltura was published. In 1584, Pope Sixtus, according to Harte (Essay, i.), forced his subjects to work, that they might pay the heavy taxes imposed on them; and by this means rendered them happy and contented, and himself rich and powerful. He found them sunk in sloth, overrun with pride and poverty, and lost to all sense of civil duties; but he recovered them from that despicable state, first to industry, and next to plenty and regularity. He effected this by a plain maxim, the practice of which however none but a great genius could have enforced, which was that "a people not pressed by taxes are apt to grow indolent, and that industry is the only source of riches and plenty to a state."*

183. *Naples being at this period a Spanish province, the wars in which Spain was engaged obliged her to put a tax upon fruit; and as fruits were not only the chief delicacies but articles of subsistence among the Neapolitans, this imposition is said to have rendered them industrious. But though some agricultural books were published at Naples during the sixteenth century, there is no evidence that they ever made much progress in culture. Their best lands are in Sicily; and on them a corn crop and a fallow was and is the rotation, and the produce seldom exceeded eight or ten for one, as in the time of the Romans. This is the case in Sicily at present; and it is not likely to have been different or at least not better from the fifth to the seventeenth centuries.*

184. *The greatest agricultural improvements in Italy which took place during the period in question, were in Tuscany and Lombardy. In the former country the culture of the vine and the olive were brought to greater perfection than any where else in Europe. The oil of Lucca and the wines of Florence became celebrated in other countries, and*

the commerce in these articles enriched the inhabitants, and enabled the proprietors to bestow increased attention to the cultivation of their estates. Lombardy excelled in the culture of corn and cattle as well as of the vine. The butter, cheese, and beef of the country, were esteemed the best in Italy. The pastures were at that time, and still are, more productive than any in Europe, or perhaps the world, having the three advantages of a climate so temperate in winter that the grass grows all the year; a soil naturally rich; and an abundant supply of river water for irrigation. The irrigation of Lombardy forms the chief feature of its culture. It was begun and carried to a considerable extent under the Romans, and in the period of which we speak extended and increased under the Lombard kings and wealthy religious establishments. Some idea may be formed of the comfort of the farmers in Lombardy in the thirteenth century, by the picture of a farm-house given by Crescenzo, who lived on its borders, which, as a French antiquarian (Paulinag) has observed, differ little from the best modern ones of Italy, but in being covered with thatch.

## SECT. II. *History of Agriculture in France from the Fifth to the Seventeenth Century.*

185. *The nations who conquered France in the fifth century* were the Goths, Vandals, and Franks. The two former nations claimed two-thirds of the conquered lands (*Leges Burgundiorum*, tit. 54.), and must of course have very much altered both the state of property, and the management of the affairs of husbandry. The claim of the Franks is more uncertain; they were so much a warlike people, that they probably dealt more favorably with those whom they subjected to their dominion.

186. *All that is known of the agriculture of these nations and of France till the ninth century* is derived from a perusal of their laws. These appear to have been favorable to cultivation, especially the laws of the Franks. Horses are frequently mentioned, and a distinction made between the war horse and farm horse, which shews that this animal was at that period more common in France than in Italy. Horses, cattle, and sheep, were pastured in the forests and commons, with bells about the necks of several of them, for their more ready discovery. The culture of vines and orchards was greatly encouraged by Charlemagne in the ninth century. He planted many vineyards on the crown lands which were situated in every part of the country, and left in his capitularies particular instructions for their culture. One of his injunctions prohibits an ox and an ass from being yoked together in the same plough.

187. *During great part of the ninth and tenth centuries*, France was harassed by civil wars, and agriculture declined; but to what extent, scarcely any facts are left us to ascertain. A law, passed in that period respecting a farmer's tilling the lands of his superior, enacts that if the cattle are so weak that four could not go a whole day in the plough, he was to join these to the cattle of another and work two days instead of one. He who kept no cattle of his own was obliged to work for his superior three days as a laborer.

188. *In the eleventh and twelfth centuries*, the country enjoyed more tranquillity, and agriculture was improved. Judging from the Abbé Suger's account of the abbey lands of St. Dennis, better farm-houses were built, waste lands cultivated, and rents more than doubled. The church published several canons for the security of agriculture during this period, which must have had a beneficial effect, as the greatest proportion of the best lands in every country were then in the hands of the clergy.

189. *In the thirteenth century* little alteration took place; but the number of holidays were diminished, and mills for grinding corn driven by wind introduced.

190. *In the fourteenth and fifteenth centuries* agriculture suffered greatly by the English wars and conquests, and by political regulations relatively to the export and market price of corn.

191. *About the middle of the sixteenth century* the first agricultural work produced in France made its appearance. It was entitled, *Les Moyens de devenir riche*, and was written by Bernard de Pallisy, a potter, who had written on various subjects. It is a very short tract, composed of economical remarks on husbandry, or rural and domestic economy. Towards the end of this century, under Henry IV., and his virtuous minister Sully, considerable enterprise was displayed. Canals were projected and one begun, and according to Sully, France in his time abounded with corn, grain, pulse, wine, cider, flax, hemp, salt, wool, oil, dyeing drugs, cattle great and small, and every thing else, whether necessary or convenient for life, both for home consumption and exportation. (*Mem. b. xvi. 225. Ranken's Hist. of France, i. 433.*)

## SECT. III. *Of the Agriculture of Germany and other Northern States from the Fifth to the Seventeenth Century.*

192. *The nations north of the Rhine and the Danube*, during the first half of these centuries, were chiefly employed in making inroads or conquests on their southern neigh-

bors; and during the whole period they were more or less engaged in attacking one another. Under such circumstances, agriculture must either have remained in the state which we have already described (178.), or it must have declined. In some states or kingdoms it may have been less neglected than in others, or may even have improved; but during the whole of this period, nothing was effected which demands particular attention.

193. *The earliest German author on husbandry* is Conradus Heresbachius, who was born in 1508, and died in 1576. His work, *De Re Rustica*, was published after his death. It is an avowed compilation from all the authors who had preceded him, and contains no information as to the state of agriculture around him. It is a dialogue in four books, and includes also gardening. The persons are Cono, a gentleman retired to the country; Rigo, a courtier; Metelea, wife of Cono; and Hermes, a servant. The conversation is carried on in Cono's house, and on his farm, and the different speakers are made to deliver all that has been said by all the Greek and Roman writers, from Hesiod to Pliny, by Crescenzo and other Italians, and by various writers on general subjects: they converse on the advantages of agriculture as a pursuit; on its general maxims and practices; on the culture of particular plants, and the economy of the house and garden.

194. *No other books on agriculture of any note appeared in Germany during the period under review.* About the middle of the sixteenth century, the Elector of Saxony, Augustus II., is said to have encouraged agriculture, and to have planted the first vineyard in Saxony; but from the implements with which he worked in person, which are still preserved in the arsenal of Dresden, he appears to have been more a gardener than a farmer. It is to be regretted that the histories of the arts in the northern countries during the middle ages are very few, and so little known or accessible, that we cannot derive much advantage from them.

#### SECT. IV. *History of Agriculture in Britain from the Fifth to the Seventeenth Century.*

195. *Britain, on being quitted by the Romans, was invaded by the Saxons, a ferocious and ignorant people, by whom agriculture, and all other civilized arts, were neglected.* In the eleventh century, when the Saxons had amalgamated with the natives, and constituted the main body of the English nation, the country was again invaded by the Normans, a much more civilized race, who introduced considerable improvement. These two events form two distinct periods in the history of British agriculture, and two others will bring it down to the seventeenth century.

##### SUBJECT. 1. *History of Agriculture in Britain during the Anglo-Saxon Dynasty, or from the Fifth to the Eleventh Century.*

196. *At the arrival of the Anglo-Saxons this island, according to Fleury, (History, vol. iv. p. 97.) abounded in numerous flocks and herds, which these conquerors seized, and pastured for their own use; and after their settlement they still continued to follow pasturage as one of the chief means of their subsistence.* This is evident from the great number of laws that were made in the Anglo-Saxon times, for regulating the prices of all kinds of tame cattle, directing the manner in which they were to be pastured, and for preserving them from thieves, robbers, and beasts of prey. (*Wilkins, Leges Saxon, passim.*)

197. *The Welsh in this period, from the nature of their country, and other circumstances, depended still more on their flocks and herds for their support; hence their laws respecting pasturage were more numerous and minute than those of the Saxons. (Leges Wallicæ, passim.)* From these laws we learn, among many other particulars, which need not be mentioned, that all the cattle of a village, though belonging to different owners, were pastured together in one herd, under the direction of one person (with proper assistants); whose oath, in all disputes about the cattle under his care, was decisive.

198. *By one of these laws, they were prohibited to plough with horses, mares, or cows, but only with oxen. (Leges Wallicæ, p. 288.)* Their ploughs seem to have been very slight and inartificial; for it was enacted, that no man should undertake to guide a plough who could not make one; and that the driver should make the ropes of twisted willows, with which it was drawn. (*Id.* p. 283.) But slight as these ploughs were, it was usual for six or eight persons to form themselves into a society for fitting out one of them, and providing it with oxen, and every thing necessary for ploughing; and many minute and curious laws were made for the regulation of such societies. This is a sufficient proof both of the poverty of the husbandmen, and of the imperfect state of agriculture among the ancient Britons in this period.

199. *Certain privileges were allowed to any person who laid dung on a field, cut down a wood, or folded his cattle on another's land for a year.* Such was the state of agriculture during this period in Wales; it was probably in a still more imperfect state among the Scots and Picts, but of this we have no means of ascertaining.



200. *Our Anglo-Saxon ancestors derived their origin and manners from the ancient Germans, who were not much addicted to agriculture, but depended chiefly on their flocks and herds for their subsistence. (Strabo, l. vii. Cæsar de Bel. Gal. l. vi.)* These restless and haughty warriors esteemed the cultivation of their lands too ignoble and laborious an employment for themselves, and therefore committed it wholly to their women and slaves. (*Tacit. de Morib. German. c. 15.*) They were even at pains to contrive laws to prevent their contracting a taste for agriculture, lest it should render them less fond of arms and warlike expeditions. (*Id. c. 26.*)

201. *The division of landed estates into what are called inlands and outlands, originated with the Saxon princes and great men, who, in the division of the conquered lands, obtained the largest shares, and are said to have subdivided their territory into two parts, which were so named. The inlands were those which lay most contiguous to the mansion-house of their owner, which he kept in his own immediate possession, and cultivated by his slaves, under the direction of a bailiff, for the purpose of raising provisions for his family. The outlands were those which lay at a greater distance from the mansion-house, and were let to the ceorls or farmers of those times at a certain rent, which was very moderate, and generally paid in kind. (Reliquæ Spelmanianæ, p. 12.)*

202. *The rent of land in these times was established by law, and not by the owners of the land. By the laws of Ina, king of the West Saxons, who flourished in the end of the seventh and beginning of the eighth century, a farm consisting of ten hides or plough lands was to pay the following rent, viz. ten casks of honey, three hundred loaves of bread, twelve casks of strong ale, thirty casks of small ale, two oxen, ten wethers, ten geese, twenty hens, ten cheeses, one cask of butter, five salmon, twenty pounds of forage, and one hundred eels. (Wilkins, Leges Saxon, p. 25.)* The greatest part of the crown lands in every county was farmed in this manner by ceorls or farmers, who in general appear to have been freemen and soldiers.

203. *Very little is known of the implements or operations of husbandry during this period. In one of Strutt's plates of ancient dresses, entitled, Saxon Rarities of the Eighth Century, may be seen a picture of a plough and ploughman. (fig. 22.)* This is sufficiently rude, though it has evidently undergone some improvement by the art of the delineator. The laborers were no doubt slaves, and the animals of draught, oxen. The lands belonging to the monasteries were by much the best cultivated; because the secular canons who possessed them, spent some part of their time in cultivating their own lands. The venerable Bede, in his life of Easterwin Abbot of Weremouth, tells us, "That this abbot, being a strong man, and of a humble disposition, used to assist his monks in their rural labors, sometimes guiding the plough by its stilt or handle, sometimes winnowing corn, and sometimes forging instruments of husbandry with a hammer upon an anvil." (*Beda, Hist. Abbat. Weremath. p. 296.*) For in those times the husbandmen were under a necessity of making many implements of husbandry with their own hands.



SUBJECT. 2. *Of the State of Agriculture in Britain after the Norman Conquest, or from the Eleventh to the Thirteenth Centuries.*

204. *That the conquest of England by the Normans contributed to the improvement of agriculture in Britain is undeniable. "For by that event many thousands of husbandmen, from the fertile and well cultivated plains of Flanders, France, and Normandy, settled in this island, obtained estates or farms, and employed the same methods in the cultivation of them that they had used in their native countries. Some of the Norman barons were great improvers of their lands, and are celebrated in history for their skill in agriculture." "Richard de Rulos, lord of Brunne and Deeping," says Ingulphus, "was much addicted to agriculture, and delighted in breeding horses and cattle. Besides inclosing and draining a great extent of country, he imbanked the river Wielland (which used every year to overflow the neighboring fields) in a most substantial manner, building many houses and cottages upon the bank; which increased so much, that in a little time they formed a large town called Deeping, from its low situation. Here he planted orchards, cultivated commons, converted deep lakes and impassable quagmires into fertile fields, rich meadows, and pastures; and, in a word, rendered the whole country about it a garden of delights." (Hist. Ingulphi. Oxon. edit. 1684, tom. i. p. 77, 78.)* From the above description, it appears that this nobleman (who was chamberlain to William the Conqueror) was not only fond of agriculture, but also that he conducted his improvements with skill and success.

205. *The Norman clergy, and particularly the monks, were still greater improvers than the nobility; and the lands of the church, especially of the convents, were conspicuous for their superior cultivation. For the monks of every monastery retained such of their lands as lay most convenient in their own possession, which they cultivated with great care, under their own inspection, and frequently with their own hands. It was so much the custom of the monks of this period to assist in the cultivation of their lands, especially in seed-time, hay-time, and harvest, that the famous Thomas Becket, after he was Archbishop of Canterbury, used to go out to the field, with the monks of the monasteries where he happened to reside, and join with them in reaping their corn and making their hay. (Chron. Gervas. col. 1400.) This is indeed mentioned by the historian as an act of uncommon condescension in a person of his high station in the church; but it is sufficient proof that the monks of those times used to work with their own hands, at some seasons, in the labors of the field: and as many of them were men of genius and invention, they no doubt made various improvements in the art of agriculture. The twenty-sixth canon of the general council of Lateran, held A.D. 1179, affords a further proof that the protection and encouragement of all who were concerned in agriculture, was an object of attention to the church. For by that canon, it is decreed, "That all presbyters, clerks, monks, converts, pilgrims, and peasants, when they are engaged in the labors of husbandry, together with the*

23



*cattle in their ploughs, and the seed which they carry into the field, shall enjoy perfect security; and that all who molest or interrupt them, if they do not desist when they have been admonished, shall be excommunicated." (Id. col. 1456.)*

206. *The implements of husbandry, in this period, were of the same kind with those that are employed at present; but some of them were less perfect in their construction. One sort of plough, for example, had but one stilt or handle, which the ploughman guided with one hand, having in his other hand an instrument which served both for cleaning and mending his plough, (fig. 23.) and breaking the clods. This implement was probably intended for breaking up strong lands; for such a purpose the wheels would contribute much to its steadiness, which would render two handles unnecessary, and thus leave the holder with one hand at liberty to use his axe-like instrument in clearing away roots and clods, or otherwise aiding the operation of the plough. Another plough (fig. 24.) seems to have been without wheels, and was probably intended for light soil. (See Strutt's Complete View of the Manners, &c. of England, vol. ii. p. 12.) The Norman plough had two*

24



25

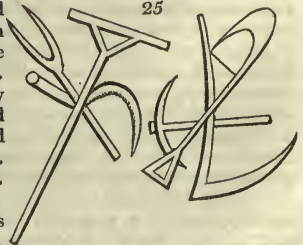

*remaining, appear to have been nearly of the same construction with those that are now used. (Strutt's View, vol. i. plate 26. 32. 33. and our fig. 25.) In Wales, they did not use a sickle in reaping their corn, but an instrument like the blade of a knife, with a wooden handle at each end. (Girald. Cam., ibid.) Water-mills for grinding corn were very common, but they had also a kind of mills turned by horses, which were chiefly used in their armies, and at sieges, or in places where running water was scarce. (Gaufrid Vinisarf. iter Hierosolymit. l. i. c. 33. M. Paris. Vit. Abbot. p. 94. col. 2.)*

207. *The various operations of husbandry, as manuring, ploughing, sowing, harrowing, reaping, threshing, winnowing, &c. are incidentally mentioned by the writers of this period; but it is impossible to collect from them a distinct account of the manner in which*

these operations were performed. Marl seems to have been the chief manure next to dung, employed by the Anglo-Norman, as it had been by the Anglo-Saxon and British husbandmen. (*M. Paris. Hist.* p. 181. *In Vit. Abbot.* p. 101. col. 1.) Summer-fallowing of lands designed for wheat, and ploughing them several times, appears to have been a common practice of the English farmers of this period. For Giraldus Cambrensis, in his description of Wales, takes notice of it as a great singularity in the husbandmen of that country, "that they ploughed their lands only once a-year, in March or April, in order to sow them with oats; but did not, like other farmers, plough them twice in summer, and once in winter, in order to prepare them for wheat." (*Giral. Cambrens. Descript. Cambriae*, c. viii. p. 887.) On the border of one of the compartments in the famous tapestry of Bayeux, we see the figure of one man sowing with a sheet about his neck, containing the seed under his left arm, and scattering it with his right hand; and of another man harrowing with one harrow, drawn by one horse. (*Montfaucon, Monumens de Monarchie Francois*, tom. i. plate 47.) In two plates of Strutt's very curious and valuable work (*figs. 26, 27.*), we perceive the figures of several persons en-



gaged in mowing, reaping, threshing, and winnowing; in all which operations there appear to be little singular or different from modern practice. (*Strutt's Complete View of the Manners, Customs, &c. of England*, vol. i. plates 11, 12.)

208. *Agriculture in Scotland* seems to have been in a very imperfect state towards the end of this period. For in a parliament held at Scone, by king Alexander II. A. D.



1214, it was enacted, that such farmers as had four oxen or cows, or upwards, should labor their lands, by tilling them with a plough, and should begin to till fifteen days before Candlemas; and that such farmers as had not so many as four oxen, though they could not labor their lands by tilling, should delve as much with hand and foot as would produce a sufficient quantity of corn to support themselves and their families. (*Regiam Majestatum*, p. 307.) But this law was probably designed for the highlands, and most uncultivated parts of the kingdom. For in the same parliament a very severe law was made against those farmers who did not extirpate a pernicious weed called *gilde* (*Chrysanthemum segetum*, L.)

out of their lands, which seems to indicate a more advanced state of cultivation. (*Id.* p. 335.) Their agricultural operations, as far as can be gathered from old tapestries and illuminated missals, were similar to those of England. Threshing appears to have been performed by women (*fig. 28.*), and reaping by the men (*fig. 29.*), which is the reverse of the modern practice in that and in most countries. Such is the account of Henry. (*History of Britain*, vol. vi. p. 173.)



209. *The field culture of the vine*, which had been commenced by the monks for their own use, was more extensively spread by the Normans. William of Malmsbury, who flourished in the early part of the twelfth century, says, there were a greater number of vineyards in the vale of Gloucester than

any where else, and that from the grapes was produced a wine very little inferior to that of France. Orchards and cyder were also abundant, and the apple trees, it is said, lined the roads in some parts of the country, as they still do in Normandy, whence in all probability the plants or at least the grafts would be imported.

SUBJECT. 3. *History of Agriculture in Britain from the Thirteenth to the Seventeenth Century.*

210. *Agriculture in the thirteenth and fourteenth centuries*, it appears, was still carried on with vigor. Sir John Fortescue, in a work in praise of the English laws, mentions the progress that had been made in planting hedges and hedge-row trees before the end of the fourteenth century. Judge Fortescue wrote his *Legum Angliæ* in the fifteenth century, but it was not published till the reign of Henry VIII. In the law book called *Fleta* (supposed to have been written by some lawyers, prisoners in the Fleet in 1340), very particular directions are given as to the most proper times and best manner of ploughing and dressing fallows. (*Fleta*, lib. ii. chap. 73. p. 163.) The farmer is there directed to plough no deeper in summer than is necessary for destroying the weeds; nor to lay on his manure till a little before the last ploughing, which is to be with a deep and narrow furrow. Rules are also given for the changing and choosing seed;—for proportioning the quantity of different kinds of seed to be sown on an acre, according to the nature of the soil, and the degree of richness;—for collecting and compounding manures, and accommodating them to the grounds on which they are to be laid;—for the best seasons for sowing seeds of different kinds on all the variety of soils;—and in a word, for performing every operation in husbandry, at the best time, and in the best manner. (*Fleta*, lib. ii. chap. 72, 73. 76.) In the same work, the duties and business of the steward, bailiff, and overseer, of a manor, and of all the other persons concerned in the cultivation of it, are explained at full length, and with so much good sense, that if they were well performed the manor could not be ill cultivated. (*Ibid.* ch. 72. 88. *Henry*, viii. 267.) This work as well as others of the kind is written in Latin, and even the farming accounts were those days kept in that language, as they still are in the greater part of Hungary.

211. *During the greater part of the fifteenth century* England was engaged in civil wars, and agriculture as well as other arts declined. The laborers, called from the plough by royal proclamation or the mandates of their lords, perished in battle or by accident and fatigue, in immense numbers. Labor rose in price notwithstanding various laws for its limitation, and this at last produced a memorable revolution in the state of agriculture, which made a mighty noise for many years. The prelates, barons, and other great proprietors of land, kept extensive tracts around their castles, which were called their demesne lands, in their own immediate possession, and cultivated them by their villains, and by hired servants, under the direction of their bailiffs. But these great landholders having often led their followers into the fields of war, their numbers were gradually diminished, and hired servants could not be procured on reasonable terms. This obliged the prelates, lords, and gentlemen to enclose the lands around their castles, and to convert them into pasture grounds. This practice of enclosing became very general in England about the middle of this period, and occasioned prodigious clamors from those who mistook the effect of depopulation for its cause.

212. *The habit of enclosing lands and converting them to pasture* continued after the cause had ceased, and an act was passed to stop its progress in the beginning of the reign of Henry VII. The dearths of this period are another proof of the low state of agriculture. Wheat in 1437 and 1438, rose from 4s. or 4s. 6d., the ordinary price per quarter, to 1l. 6s. 8d., equivalent to 13l. 6s. 8d. of our money. Stow observes that in these extremities the common people endeavored to preserve their wretched lives by drying the roots of herbs and converting them into a kind of bread. Land in those days were sold for ten years' purchase, so great was the insecurity of possession.

213. *Agriculture in Scotland* was at a low ebb during the thirteenth, fourteenth, and fifteenth centuries, on account of the long and ruinous wars in which the country was engaged. A law passed in 1424 enacts, that every laborer of "simple estate" dig a piece of ground daily, of seven feet square. Another in 1457, that farmers who had eight oxen should sow every year one firloft (bushel) of wheat, half a firloft of pease, and forty of beans, under the pain of ten shillings to be paid to the baron; and if the baron did not do the same thing to the lands in his possession, he should pay the same penalty to the king.

214. *From the accession of Henry VII. in 1485, to nearly the middle of the seventeenth century*, England enjoyed peace. The effects of former wars, however, required a considerable time to remove. The high price of labor, and the conversion of so much land to tillage, gave rise to different impolitic statutes, prohibiting the exportation of corn; while a great demand was created for wool by the manufacturers of the Netherlands, which tended to enhance the value of pasture lands, and depopulate the country. The flocks of individuals, in these times, sometimes exceeded twenty thousand; and an act was passed by Henry VIII., restricting them to a tenth of that number, ap-

parently eluded by the partial exception of hereditary opulence. Had the restraints imposed on the exportation of corn been transferred to wool, the internal consumption would have soon regulated the respective prices of those articles; the proportion between arable and pasture lands would soon have been adjusted, and the declining cultivation of the country prevented. An improved cultivation was reserved, however, for a future period, when persecutions extirpated manufactures from the Netherlands; when the exportation of English wool had subsided, and its price diminished, the farmer or landholder, disappointed of his former exuberant profits, discovered the necessity of resuming the plough, and again restoring his pastures to culture. (*Henry*, xii. 261.)

215. *The first English treatise on husbandry* appeared during Henry VIII.'s reign, by Sir A. Fitzherbert, judge of the common pleas. It is entitled *The Book of Husbandry*, and contains directions for draining, clearing, and enclosing a farm; and for enriching and reducing the soil to tillage. Lime, marl, and fallowing are strongly recommended. The landlords are advised to grant leases to farmers who will surround their farms, and divide them by hedges into proper enclosures; by which operation, he says, "if an acre of land be worth six pens (folds of sheep), before it be enclosed, it will be worth eight pens when it is enclosed, by reason of the compost and dunging of the cattle." Another reason is, that it will preserve the corn without the expence of a herdsman. From the time of the appearance of this work, in 1534, Harte dates the revival of husbandry in England.

216. *The culture of hops* in the present period was either introduced or revived in England; and flax was attempted, but without success, though enforced by law. (*Holinshead*, p. 110, 111. 24 *Hen.* 8. c. 4.) Legislature at that time endeavored to execute, by means of penalties, those rational improvements which have since been fostered and cherished by bounties; or what is better pursued from the common motive of self-interest.

217. *The breeding of horses* was now much encouraged. To the passion of the age, and the predilection of the monarch for splendid tournaments, may be attributed the attention bestowed on a breed of horses of a strength and stature adapted to the weight of the complicated panoply with which the knight and his courser were both invested. Statutes of a singular nature were enacted, allotting for deer parks a certain proportion of breeding mares, and enjoining, not the prelates and nobles only, but those whose wives wore velvet bonnets, to have stallions of a certain size for their saddle. The legal standard was, fifteen hands in horses, thirteen in mares, and "unlikely tits" were, without distinction, consigned to execution. (27 *Hen.* 8. cap. 6. 36 *Hen.* 8. cap. 13. Vide *Barrington's Observations on the Statutes*, p. 443.) James the Fourth, with more propriety, imported horses from foreign countries to improve the degenerate breed of his own. (*Pitcottie*, p. 153.) Artificial grasses for their winter provender were still unknown; nor were asses propagated in England till a subsequent period. (*Holinshead*, p. 220. *Polydore, Virgil*, p. 15. *Henry*, xii. 268.)

218. *Of the state of agriculture in Scotland* during the fifteenth and sixteenth centuries little can be stated. According to Major (*Historia Britannicæ*, Paris, 1526.), a native of Berwick, "the peasants neither enclosed nor planted, nor endeavored to ameliorate the sterility of the soil." Such wheat as was required, must have been supplied from other countries; for, according to Fynnys Moryson, the produce of the country consisted chiefly of oats and barley. Different laws were enacted for planting groves and hedges, and pruning orchards, gardens, and parks for deer: but it is not the barren injunctions of statutes that will excite a spirit of improvement in a country.

#### SUBJECT. 4. *History of Agriculture from the Death of Henry VIII. in 1547, to the Revolution in 1688.*

219. *Agriculture, soon after the beginning of the sixteenth century*, partook of the general improvement which followed the invention of the art of printing, the revival of literature, and the more settled authority of government; and, instead of the occasional notices of historians, we can now refer to regular treatises, written by men who engaged eagerly in this neglected, and hitherto degraded, occupation.

220. *The first and best of early agricultural works* is, *The Book of Husbandry*, already mentioned (215.), printed in 1534. This was followed, in 1539, by *The Book of Surveying and Improvements*, by the same author. In the former treatise we have a clear and minute description of the rural practices of that period; and from the latter may be learned a good deal of the economy of the feudal system in its decline. The author of *The Book of Husbandry* writes from his own experience of more than forty years; and, if we except his biblical allusions, and some vestiges of the superstition of the Roman writers about the influence of the moon, there is very little of his work that should be omitted, and not a great deal that need be added, in so far as regards the culture of corn, in a manual of husbandry adapted to the present time. It may surprise some of the agriculturists of the present day, an eminent agricultural writer remarks, to be told, that, after the lapse of almost three centuries, Fitzherbert's practice,

in some material branches, has not been improved upon; and that in several districts abuses still exist, which were as clearly pointed out by him at that early period as by any writer of the present age. His remarks on sheep are so accurate that one might imagine they came from a storemaster of the present day. Those on horses, cattle, &c. are not less interesting; and there is a very good account of the diseases of each species, and some just observations on the advantage of mixing different kinds in the same pasture. Swine and bees conclude this branch of the work. He then points out the great advantages of enclosures; recommends "quycksettyng, dychyng, and hedgyng;" and gives particular directions about the *settes*, and the method of training a hedge, as well as concerning the planting and management of trees. We have then a short information "for a yonge gentylman that intendeth to thryve," and a "proulge for the wives' occupation," in some instances, rather too homely for the present time. Among other things, she is to "make her husband and herself some clothes;" and "she may have the lockes of the shepe, either to make blankettes and coverlettes, or both." This is not so much amiss; but what follows will bring our learned judge into disrepute, even with our most industrious housewives. "It is a wive's occupation to wyne all manner of cornes, to make malte, to washe and wryng, to make heye, shere corne, and, in time of nede, to helpe her husbände to fyll the muckewayne or dounge carte, drive the ploughe, to loade heye, corne, and suche other. And to go or ride to the market, to sel butter, chese, mylke, egges, chekyns, capons, hennes, pygges, gese, and all manner of cornes." The rest of the book contains some useful advices about diligence and economy; and concludes, after the manner of the age, with many pious exhortations. (*Encyc. Brit. art. Agr.*)

221. *The state of agriculture in England in the early part of the sixteenth century, and probably for a long time before, is thus ascertained; for Fitzherbert no where speaks of the practices which he describes or recommends as of recent introduction. The Book of Surveyinge adds considerably to our knowledge of the rural economy of that age. "Four maner of commens" are described; several kinds of mills for corn, and other purposes, and also "quernes that goo with hand;" different orders of tenants, down to the "boundmen," who, "in some places contynue as yet;"—"and many tymes, by color thereof, there be many freemen taken as boundmen, and their lands and goods is taken from them." Lime and marl are mentioned as common manures; and the former was sometimes spread on the surface to destroy heath. Both draining and irrigation are noticed; though the latter but slightly. And the work concludes with an inquiry "How to make a township that is worth XX marke a yere worth XX li. a-year:" this is to be done by enclosing, by which, he says, live stock may be better kept and without herds; and the closes or fields alternately cropped with corn, and "let lye" for a time.*

222. *Agriculture had attained a considerable degree of respectability during the reign of Elizabeth. According to Tusser, who wrote in that age, and whose work will be afterwards noticed, agriculture was best understood in Essex and Suffolk; at least enclosures were more common in these counties than in any other, which is always a proof of advancement. A farmer, according to Harrison the geographer, "will thinke his gaines very small towards the end of his terme if he have not six or seven years rent lieing by him, therewith to purchase a new lease; beside a fair garnish of pewter on his cupboard, with as much more in odd vessels going about the house; three or four featherbeds; so many coverlets, and carpets of tapestrie; a silver salt; a bowle for wine, if not a whole neast; and a dozen of spoones to furnish owte the sute." (Harrison's Description of England, p. 188.)*

223. *The condition of a yeoman before or about Elizabeth's time, is exemplified in the case of Bishop Latimer's father. "My father," says Hugh Latimer, "was a yeoman, and had no land of his own; only he had a farm of three or four pounds by the year at the utmost; and hereupon he tilled so much as kept half a dozen men. He had a walk for a hundred sheep; and my mother milked thirty kine, &c. He kept his son at school till he went to the university, and maintained him there; he married his daughters with five pounds, or twenty nobles a-piece; he kept hospitality with his neighbours, and some alms he gave to the poor; and all this he did out of the said farm." (Gulpin's Life of Latimer.)*

224. *Cattle were not plentiful in England at the beginning of Elizabeth's reign. In 1563 it was enacted, that no one should eat flesh on Wednesdays or Fridays, on forfeiture of three pounds, unless in case of sickness, or of a special licence, neither of which was to extend to beef or veal. (Stat. 5 Eliz. cap. 4.) Great pains were taken in the act to prove that it was a political, not a religious measure.*

225. *The vast number of parks in the kingdom are complained of by Harrison. "There are not less," he says, "than an hundred in Essex alone, where almost nothing is kept but a sorte of wilde and savage beasts, cherished for pleasure and delight." And pursuing the same subject, he says, "that if the world last a while after this rate, wheate and risse will be no graine for poore men to feed on." (Description of Britaine, p. 168.)*

226. *In Scotland* the civil dissensions, and even anarchy, which prevailed until a late period in the sixteenth century, operated as a harsh check on every improvement in agriculture. Even the total expulsion of ecclesiastical landholders increased this evil; as the monks were easy landlords, and frequently not uninstruced in georgical knowledge. The tillers of the earth in Scotland had at least their full share of their country's misfortunes, when private vengeance for private wrongs superseded the regular but timid proceedings of public justice. A statute was then formed for their particular benefit, whereby (*Stat. 110. Parl. 7 Jac. 6.*) "the slayers and houchers (houghers) of horses and uther cattel," with their employers and maintainers, are declared "to have incurred the paine of death, and confiscation of all their gudes movvabil." A second act passed in 1587 for the further protection of husbandmen, declaring all such as destroyed or maimed horses, oxen, &c., cut or destroyed ploughs or plough-geers (in time of tilling), or trees and corn, should suffer death. (*Stat. 83. Parl. 2 Jac. 6.*) Several acts of parliament were made to protect the farmers from petulant tithe-gatherers; the proper times of notice were herein pointed out, and liberty given to the tiller of the land to proceed in his work if this notice was neglected. The last (*Stat. 84. Parl. 2 Jac. 6.*) confirmed and explained the others. (*Andrew's Continuation of Henry's Hist. ii. 124.*)

227. *Great attention was still paid to the breed of horses in England*; but during the reign of Elizabeth it was found necessary to lower the standard appointed by Henry VIII. for stallions, from fourteen hands to thirteen. This modification, however, was only to take place in the counties of Cambridge, Huntingdon, Northampton, Lincoln, Norfolk, and Suffolk. (*8 Eliz. cap. 8.*) No stallion of less height could be turned out on commons, forests, &c. for fear of diminishing the breed. Harrison extols the height and strength of the English draught-horses; five or six of them, he says, will with ease draw three thousand weight of the greatest tale for a long journey. As to the number of horses in the realm, some judgment may be formed from the quota which Elizabeth, when she moved her place of residence, demanded from the country in the neighborhood of her palace. This was 24,000; "a far less traine," says the reverend writer, "than those of the kings of other nations." (*Description of Britaine, p. 220.*)

228. *An English traveller, who visited Scotland in 1598, observed a great abundance of all kind of cattle, and many horses*; not large, but high-spirited and patient of labor. (*Moryson's Itin. part iii. p. 154.*) Great care, indeed, was taken by the English, while the kingdoms were separate, to prevent the Scots from improving their breed by southern stallions; it was even made felony to export horses thither from England. (*1 Eliz. cap. 7.*) This unneighborly prohibition was answered by a reciprocal restriction in 1567, as to the exportation of Scottish horses (*Stat. 22. Parl. 1 Jac. 6.*); but France, rather than England, seems to be pointed out by that statute. One circumstance pointed out by a curious antiquary (*Paper apud Transactions of Sc. Aut. Soc. vol. i. p. 171.*), is a convincing proof of the modern improvement in the breed. For many years past eight nails have been used to each horse's shoe in the north; six used to be the number.

229. *The proper season for turning horses to grass* was thought a consideration worthy the attention of the Scottish government, avowedly to prevent the waste of corn. All horses were, therefore, ordered to be put to grass from May 15 to Oct. 15, on pain of forfeiting each horse, or its value, to the king. Gentlemen of 1000 marks, yearly rent, and all upwards, are excepted. (*Stat. 122. Parl. 7 Jac. 6.*) The 1st of June was substituted in a subsequent act (*Stat. 56. Parl. 2 Jac. 6.*) for the 15th of May.

230. *The vine in England continued to be cultivated for wine*; but not generally, for the vineyards of the Lords Cobham and Williams of Thames, are pointed out by Barnaby Gooch as eminently productive. It is probable this branch of culture declined with the suppression of the monasteries, and the more general culture of barley; as farmers and others would soon find that good beer was a cheaper and better drink than any wine that could be made in this country. Though the potatoe was introduced in this reign by Capt. Hawkins from Santa Fé in 1565, yet it did not come into general use, even in gardens, for nearly two centuries afterwards.

231. *The principal agricultural authors of Elizabeth's reign* are, Tusser, Googe, and Sir Hugh Platt. Thomas Tusser was born at Rivenhall in Essex, in 1527. Having a fine voice, he was impressed for the royal chapel, and sang in St. Paul's, under a celebrated musician. "Afterwards he was a scholar at Eton, and next a student at Cambridge. He next became, by turns, musician, farmer, grazier, and poet; but always unsuccessfully, although guilty neither of vice nor extravagance." His *Five Hundred Points of Husbandry* was published in 1562, and has been recommended by Lord Molesworth to be taught in schools. (*Some Considerations for the promoting of Agriculture and employing the Poor, Dublin, 1723.*) It is written in hobbling verse, and contains some useful notices concerning the state of agriculture in different parts of England. Hops, which had been introduced in the early part of the sixteenth century, and on the culture of which a treatise was published, in 1574, by Reynolde Scott, are mentioned as a well-known crop. Buck-wheat was sown after barley. It seems to have been the practice then, in some places, to "geld fillies" as well as colts. Hemp and flax are mentioned as common crops. Enclosures must have been numerous in several counties;

and there is a very good "comparison between champion (open fields) country, and severall." There is nothing to be found in Tusser about *serfs*, or bondmen, as in Fitzherbert's works. (*Encyc. Brit. art. Agricul.*)

232. The next writer is Barnaby Googe, a Lincolnshire gentleman, whose *Whole Art of Husbandry* was printed in 1758. It is, for the most part, made up of gleanings from all the ancient writers of Greece and Rome, whose absurdities are faithfully retained; with here and there some description of the practices of the age, in which there is little novelty or importance. Googe mentions a number of English writers who lived about the time of Fitzherbert, whose works have not been preserved.

233. Sir Hugh Platt's *Jewel Houses* of art and nature was printed in 1594. It is chiefly a compilation from other writers. The author appears to have been a lawyer of Lincoln's Inn, but he had a seat in Essex, and another in Middlesex, where he spent great part of his time. The Rev. William Harrison, a contemporary of Platt, and chaplain to baron Cobham, wrote a description of Britain, and translated Boethius's History of Scotland. In the former work are many valuable hints on the progress of husbandry in the early part of the reign of Elizabeth. Among other curious things he asserts that the Spanish, or Merino sheep, was originally derived from England.

234. The seventeenth century is distinguished by some important improvements in agriculture, among which are the introduction of clovers and turnips in England; of hedges in Scotland and Ireland; and the execution of extensive embankments and drainages. Some useful writers also appeared, especially Norden, Gabriel Plattes, Sir Richard Weston, Hartlib, and Blythe, to which may be added Evelyn.

235. For the adoption of the clover and turnip as agricultural plants, we are indebted to Sir Richard Weston, who, in 1645, gives an account of their culture in Flanders, where, he says, he "saw it cutting near Antwerp on the 1st of June 1644, being then two feet long, and very thick; that he saw it cut again on the 29th of the same month, being twenty inches long; and a third time in August, being eighteen inches long." Blythe, in 1653, is copious in his directions for its cultivation; and Lisle (*Obs. on Husbandry*), in the beginning of the eighteenth century, speaks of it as commonly cultivated in Hampshire, Wiltshire, Gloucestershire, and other counties.

236. Turnips, the same patriotic author observes, "are cultivated for feeding kine in many parts of England; but there is as much difference between what growth in Flanders and here, as is between the same thing which growth in a garden and that which growth wild in the fields." It is probable the English turnips he alludes to, were rape, which is mentioned by Googe, in 1586: but though Gerarde, in 1597, and Parkinson, in 1629, mention the turnip as a garden vegetable, yet neither of these authors give the least hint of their field culture; be that as it may, Ray, in 1686, informs us, that they are sown every where in fields and gardens both in England and abroad for the sake of their roots. Lisle also, in 1707, mentions their being common in Norfolk, Hampshire, Berkshire, and various counties. The common story, therefore, that their culture was first introduced by Charles Lord Viscount Townsend, cannot be true; but their culture was probably greatly improved by him, when he retired from public business to Rainham in Norfolk, in 1730.

237. The first notices of sheep being fed on the ground with turnips, is given in Houghton's *Collections on Husbandry and Trade*, a periodical work begun in 1681. In 1684, Worlidge, one of Houghton's correspondents, observes, "sheep fatten very well on turnips, which prove an excellent nourishment for them in hard winters, when fodder is scarce; for they will not only eat the greens, but feed on the roots in the ground, and scoop them hollow even to the very skin." "Ten acres," he adds, "sown with clover, turnips, &c. will feed as many sheep as one hundred acres thereof would before have done." (*Houghton's Collections*, vol. iv. p. 142—144.)

238. Potatoes, first introduced in 1565, (230.) were at this time beginning to attract notice. "The potatoe," says Houghton, "is a *bacciferous* herb with *esculent* roots, bearing winged leaves, and a bell flower."—"This, I have been informed, was brought first out of Virginia by Sir Walter Raleigh; and he stopping at Ireland, some was planted there, where it thrived very well, and to good purpose; for in their succeeding wars, when all the corn above ground was destroyed, this supported them; for the soldiers, unless they had dug up all the ground where they grew, and almost sifted it, could not extirpate them. From thence they were brought to Lancashire, where they are very numerous, and now they began to spread all the kingdom over. They are a pleasant food, boiled or roasted, and eaten with butter and sugar. There is a sort brought from Spain that are of a longer form, (*Convolvulus batatas*), (fig. 30.), and are more luscious than ours; they are much set by, and sold for sixpence or eightpence the pound." (*Ib.* vol. ii. p. 468.)





239. *Embankments* were made on the eastward of England, in various places by the Romans, when in possession of the country, and afterwards by some wealthy religious houses, and the government. Considerable exertions were made at Boston during the reign of Henry VII., under the direction of Mayhew Hake, a Flemish engineer, and fourteen masons: but the principal effort, as far as respects gaining land for agricultural purposes, was made under Cromwell's reign, by Col. Vermuyden, a Fleming, who served in his army. Speaking of this engineer's exertions, Harte observes, "if my account stands right (and it comes from the best authority extant), our kingdom in the space of a few years, till the year 1651 only, had recovered, or was on the point of recovering, in Lincolnshire, Cambridgeshire, Huntingdonshire, and Kent, 425,000 acres of fens and morasses, which were advanced in general, from half-a-crown an acre to twenty and thirty shillings. So that, perhaps, few statesmen and generals have better deserved a statue or monument from this country than Vermuyden, the principal undertaker."

240. *The exportation of corn* was regulated by various laws, during the sixteenth century; and importation was not restrained even in plenty and cheapness. In 1663 was passed the first statute for levying tolls at turnpikes. Enclosures by consent and by act of parliament began also to be made during this century.

241. *The agriculture of Scotland during the fifteenth and sixteenth centuries* continued to languish, especially upon the estates of the barons, where the profession of a soldier was regarded as of greater importance than that of a cultivator of the ground; but the ecclesiastical lands were considerably improved, and the tenants of them were generally much more comfortably circumstanced than those upon the estates of laymen. The reformation of religion, beneficial as it was in other respects, rather checked than promoted agricultural improvement; because the change of property, which then occurred, occasioned a similar change of tenantry, and almost took husbandry out of the hands of the monks, the only class of people by whom it was practised upon correct principles. The dissolution of the monasteries and other religious houses was also attended by injurious consequences in the first instance; though latterly the greatest benefit has been derived from tithes and church lands having come into the hands of laymen. It is probable, had not these circumstances occurred, that the tithe system would have still remained in force, and Scottish husbandry have continued under a burthen, which sinks and oppresses the cultivator of England and Ireland. But tithes having got into the hands of lay titulars, or impropriators, were in general collected or farmed with such severity as to occasion the most grievous complaints, not only from the tenantry, but also from the numerous class of proprietors, who had not been so fortunate as to procure a share of the general spoil. This, added to the desire shown by the crown to resume the grants made when its power was comparatively feeble, occasioned the celebrated submission to Charles I., which ended in a settlement, that in modern times has proved highly beneficial, not only to the interest of proprietors, but likewise to general improvement. Tithes, in fact, are a burthen, which operate as a tax upon industry, though it was a long time before the beneficial consequences of withdrawing them were fully understood. (*Edin. Encyc. art. Agr.*)

242. *Of the state of agriculture in Scotland during the greater part of the seventeenth century very little is known*; no professed treatise on the subject appeared till after the revolution. The south-eastern counties were the earliest improved, and yet, in 1660, their condition seems to have been very wretched. Ray, who made a tour along the eastern coast in that year, says, "We observed little or no fallow grounds in Scotland; some ley ground we saw, which they manured with sea wreck. The men seemed to be very lazy, and may be frequently observed to plough in their cloaks. It is the fashion of them to wear cloaks when they go abroad, but especially on Sundays. They have neither good bread, cheese, nor drink. They cannot make them, nor will they learn. Their butter is very indifferent, and one would wonder how they could contrive to make it so bad. They use much pottage made of coalwort, which they call *kail*, sometimes broth of decorticated barley. The ordinary country houses are pitiful cots, built of stone, and covered with turfs, having in them but one room, many of them no chimneys, the windows very small holes, and not glazed. The ground in the valleys and plains bears very good corn, but especially bears barley or bigge and oats, but rarely wheat and rye." (*Select Remains of John Ray. Lond. 1760.*)

243. *It is probable that no great change had taken place in Scotland from the end of the fifteenth century except that tenants gradually became possessed of a little stock of their own, instead of having their farms stocked by the landlord.* "The minority of James V., the reign of Mary Stewart, the infancy of her son, and the civil wars of her grandson Charles I., were all periods of lasting waste. The very laws which were made during successive reigns for protecting the tillers of the soil from spoil, are the best proofs of the deplorable state of the husbandman." (*Chalmers's Caledonia, vol. ii. p. 732. Encyc. Brit. art. Agr.*)

244. *The accession of James V. to the crown of England* is understood to have been unfavorable to the agricultural interest of Scotland; inasmuch as the nobles and gentry

being by that event led into great expenses, raised the rents of the tenantry considerably, whilst the very circumstance which occasioned the rise, contributed to lessen the means of the tenant for fulfilling his engagements. Scotland, however, was much benefited by the soldiers of Cromwell, who were chiefly English yeomen, not only well acquainted with husbandry, but, like the Romans at a former period, studious also to improve and enlighten the nation which they had subdued. The soldiers of Cromwell's army were regularly paid at the rate of eightpence per day, a sum equal at least to the money value of two shillings of our currency; and as this army lay in Scotland for many years, there was a great circulation of money through the country. Perhaps the low country districts were at that time in a higher state of improvement than at any former period. In the counties of Lanark, Renfrew, Ayr, and Kircudbright, the rentals of various estates were greater in 1660 than they were seventy years afterwards; and the causes which brought about a declension in value are ascertained without difficulty. The large fines exacted from country gentlemen and tenants in these counties, during the reign of Charles II. and his brother James, were almost sufficient to impoverish both proprietors and cultivators, had they even been as wealthy as they are at the present day. In addition to those fines, the dreadful imprisonments, and other oppressive measures pursued by those in power, equally contrary to sound policy and to justice and humanity, desolated large tracts, drove the oppressed gentry and many of their wealthy tenants into foreign countries, and extinguished the spirit of industry and improvement in the breasts of those who were left behind.

245. *Yet in the seventeenth century were those laws made which paved the way for the present improved system of agriculture in Scotland.* By statute 1633, landholders were enabled to have their tithes valued, and to buy them either at nine or at six years purchase, according to the value of the property. The statute 1685, conferring on landlords a power to entail their estates, was indeed of a very different tendency, in regard to its effects on agriculture. But the two acts in 1695, for the division of commons, and separation of intermixed properties, have facilitated in an eminent degree the progress of improvement. (*Ency. Brit. art. Agr.*)

246. *The literary history of agriculture during the seventeenth century* is of no great interest till about the middle of that period. For more than fifty years after the appearance of Gooche's work, there are no systematic works on husbandry, though several treatises on particular departments of it. From these it is evident, that all the different operations of the farmer were performed with more care and correctness than formerly; that the fallows were better worked; the fields kept free of weeds, and much more attention paid to manures of every kind. A few of the writers of this period deserve to be shortly noticed.

247. Sir John Norden's *Surveyor's Dialogue*, printed in 1607, is a work of considerable merit. The first three books of it relate to the rights of the lord of the manor, and the various tenures by which landed property was then held, and the obligations which they imposed: among others, we find the singular custom, so humorously described in the *Spectator*, about the incontinent widow riding upon a ram. In the fifth book, there are a good many judicious observations on the "different natures of grounds, how they may be employed, how they may be bettered, reformed, and amended." The famous meadows near Salisbury are mentioned; and when cattle have fed their fill, hogs, it is pretended, "are made fat with the remnant, namely, with the knots and sappe of the grasse." So many extravagant assertions have been made about these meadows by several of our early writers, that we ought to receive their statements with some degree of scepticism, wherever they seem to approach the marvellous. "Clover grass, or the grass honeysuckle," (white clover), is directed to be sown with other hay-seeds. "Carrot-roots" were then raised in several parts of England, and sometimes by farmers." London street-dung, and stable-dung, was carried to a distance by water; though it appears from later writers to have been got almost for the trouble of removing. And leases of twenty-one years are recommended for persons of small capital, as better than employing it in purchasing land; — an opinion that prevails very generally among our present farmers.

248. *Bees* seem to have been great favorites with these early writers; and among others, there is a treatise by Butler, a gentleman of Oxford, called the *Feminine Monarchie*, or the *History of Bees*, printed in 1609, full of all manner of quaintness and pedantry.

249. *Markham, Mascal, Gabriel Plattes, Weston*, and other authors belonged to this period. In Sir Richard Weston's *Discourse on the Husbandry of Brabant and Flanders*, published by Hartlib, in 1645, we may mark the dawn of the vast improvements which have since been effected in Britain. This gentleman was ambassador from England to the Elector Palatine and King of Bohemia, in 1619, and had the merit of being the first who introduced the *great clover*, as it was then called, into English

agriculture, about 1655, and probably turnips also. In less than ten years after its introduction, that is, before 1645, the culture of clover, exactly according to the present method, seems to have been well known in England; and it had then made its way even to Ireland.

250. *A great many works on agriculture appeared during the time of the commonwealth*, of which Blythe's *Improver Improved*, and Hartlib's *Legacy*, are the most valuable. The first edition of the former was published in 1649, and of the latter in 1650; and both of them were enlarged in subsequent editions. In the first edition of the *Improver Improved*, no mention is made of clover, nor in the second of turnips; but, in the third, published in 1662, clover is treated of at some length; and turnips are recommended as an excellent cattle crop, the culture of which should be extended from the kitchen garden to the field. Sir Richard Weston must have cultivated turnips before this; for Blythe says, that "Sir Richard affirmed to himself, he did feed his swine with them; they were first given boiled, but afterwards the swine came to eat them raw," and, "would run after the carts and pull them forth as they gathered them;" an expression which conveys an idea of their being cultivated in the fields.

251. *Blythe's book is the first systematic work in which there are some traces of the convertible husbandry*, so beneficially established since, by interposing clover and turnip between culmiferous crops. He is a great enemy to commons and common fields; and to retaining land in old pasture, unless it be of the best quality. His description of different kinds of ploughs is interesting; and he justly recommends such as were drawn by two horses (some even by one horse), in preference to the weighty clumsy machines which required four horses or oxen, or more. Almost all the manures now used seem to have been then well known; and he brought lime himself from a distance of twenty miles. He speaks of an instrument which ploughed, sowed, and harrowed at the same time; and the *setting of corn* was then a subject of much discussion. "It was not many years," says Blythe, "since the famous city of London petitioned the parliament of England against two anusancies or offensive commodities, which were likely to come into great use and esteem; and that was Newcastle coal, in regard of their stench, &c.; and hops, in regard they would spoye the taste of drinck, and endanger the people!"

252. *Hartlib's Legacy* is a very heterogeneous performance, containing among some very judicious directions, a great deal of rash speculation. Several of the deficiencies which the writer (R. Child) complains of in English agriculture, must be placed to the account of our climate, and never have been nor can be supplied.

253. *Houghton's valuable collections of husbandry* have been already mentioned. (237.)

254. *Worlidge's Systema Agricultura* was published in 1668; it treats of improvements in general, of inclosing of meadows and pastures, and of watering and draining them. Of clovers, vetches, spurry Wiltshire long-grass, (probably that of the meadows of Salisbury-iorin), hemp, flax, rape, turnips, &c. A Persian wheel was made by his direction in Wiltshire, in 1665, that carried water in good quantity above twenty feet high, for watering meadows, and another near Godalming in Surrey. Sowing clover and other seeds, preserved the cattle in the fatal winter of 1673, in the southern parts of England; whereas in the western and northern, through defect of hay and pasture, the greater part of their cattle perished. Hops enough were not planted, but we imported them from the Netherlands of a quality not so good as our own. The authors he chiefly quotes are Weston, Hartlib, and Blythe.

255. *Among other writers of this century* may be mentioned Bacon, who, in his natural history, has some curious observations on agriculture; Ray, the botanist, whose works are rich in facts; and Evelyn, a great encourager of all manner of improvements, as well as a useful writer on planting.

256. *Some of the works of the sixteenth and seventeenth centuries* are now very scarce, and most of them little known to agriculturists of the present day. In almost all of them there is much that is now useless, and not a little trifling and foolish; yet the labor of perusal is not altogether fruitless. He who wishes to view the condition of the great body of the people during this period, as well as the cultivator who still obstinately resists every new practice, may, each of them, be gratified and instructed, in tracing the gradual progress of improvement, both in enjoyment and useful industry. (*Encyc. Brit. art. Agr.*)

#### SECT. V. *History of Agriculture in ultra European Countries during the Middle Ages.*

257. *The general history of the old ultra European countries* during this period, is not known with sufficient precision and detail to enable us to give a progressive account of their agriculture. There is no evidence of any improvement having been made in the agriculture of the Indian and Chinese nations from the earliest period of their known history to the present time. The agriculture of Persia, of the African shores of the Mediterranean sea, and of all the countries under the Turks, seems, if any change has taken place, rather to have declined than advanced during the latter centuries of the middle ages.

258. *The history of the new ultra European countries of America and Australasia* only dates its commencement (with the exception of part of America) from the latter end of the period under notice; and therefore cannot furnish sufficient materials for any useful account of their agriculture. Under these circumstances we think it better to defer an

account of the origin and progress of ultra European agriculture till the succeeding chapter, where it will precede some account of its present state. We have adopted the same plan with respect to the agriculture of some of the northern European nations, as Russia, Sweden, and Spain, and also of Ireland.

#### CHAP. IV.

##### *Present State of Agriculture in Europe.*

259. *Agriculture began to be studied as a science* in the principal countries of Europe about the middle of the 16th century. The works of Crescenzo in Italy, Liebhaut in France, Heresbach in Germany, Herera in Spain, and Fitzherbert in England, all published about that period, supplied the materials of study, and led to improved practices among the reading agriculturists. The art received a second impulse in the middle of the century following, after the general peace of Aix-la-Chapelle. Then, as Harte has observed (*Essays*, i. p. 62.), "almost all the European nations, by a sort of tacit consent, applied themselves to the study of agriculture, and continued to do so, more or less, even amidst the universal confusion that soon succeeded." During the 18th century, the march of agriculture has been progressive throughout Europe, with little exception; and it has attained to a very considerable degree of perfection in some districts of Italy, in the Netherlands, and in Great Britain. In Spain it has been least improved, and it is still in a very backward state in most parts of Hungary, Poland, and Russia. We shall, in the following sections, give such notices of the agriculture of these and the other countries of Europe as our limits permit, and refer our readers to original works containing more ample information.

##### SECT. I. *Of the present State of Agriculture in Italy.*

260. *Italy is the most interesting country of Europe in respect to its rural economy.* Its climate, soils, rivers, and surface are so various, as to have given rise to a greater variety of culture than is to be found throughout the rest of Europe; while the number of governments and petty states into which it is divided have occasioned an almost equally great variety in the tenure of land, and the political circumstances which affect the cultivator. The great advantage which Italy possesses over the rest of Europe, in an agricultural point of view, is its climate; for though, as professor Symonds has shewn (*Annals of Agric.* vol. i.), it is, in point of health and agreeableness, one of the worst in the world; yet, the cool temperature of some of the northern districts admits of the finest pastures; while, from the warmth of others, the rocky sides of hills are as productive of grapes and olives as the plains are in corn. It is the only country in Europe, with the exception of some parts of Spain, where corn, grass, butchers' meat, cheese, butter, rice, silk, cotton, wine, oil, and fruits are produced, all in the highest degree of perfection. Only a fifth of its surface is considered sterile; while only a fifth of the surface of France is considered fertile. The population of Italy is greater in proportion to the surface, than that of either France or Britain.

261. *The writers on the rural economy of Italy* are, Arthur Young, in 1788; Sigismondi, in 1801; and, Chateauxvieux, in 1812. From the works of these authors, from those of Forsyth, Wilson, and other recent tourists, and from our own observations in 1819, we shall select some of the most characteristic traits as to the agriculture of Italy, adopting the division of Chateauxvieux of the region of irrigation, and the rotation of crops, in Lombardy; the region of vines and olives exemplified in Tuscany; the region of insalubrious air, or the states of the church; and the region of volcanic ashes, or the Neapolitan culture.

##### SUBSECT. 1. *Of the Agriculture of Lombardy.*

262. *The climate of Lombardy* is less irregular than that of some other districts. It is temperate on the declivities of the mountains in Piedmont, where the richest sheep-pastures are produced; subject to great vicissitudes and to severe storms at the base of the Alps, and warm and humid in the plain of the Po. In some parts the olive and the orange endure the open air throughout the year, as in the islands of the lakes; in other places, at Milan for example, they require nearly as much protection in winter as in England.

263. *The soil of the plain of the Po* has evidently been formed by the recession or deposition of water, and is a rich black mould, deep, and every where perfectly level.

264. *These lands are every where enclosed*, either with hedges and ditches, or with open water-courses, for irrigation. The hedges, however, are not very well kept; they are a mixture of different plants; often chiefly of willows; occasionally of the mulberry for

feeding the silkworms, and sometimes of reeds. The hedge-plants of the country are the Christ's thorn (*saxifragus paliurus*, L. fig. 31.), common hawthorn, and pomegranate.

265. *The lands are generally farmed by metayers* (from *meta*, Lat. *one half*.) The landlord pays the taxes, and repairs the buildings. The tenant provides cattle, implements, and seed; and the produce is divided. In some cases the landlord's half is delivered to him in kind; in others it is valued annually at harvest, and paid in money, or partly in money, and partly in produce. There are some farmers who have leases, generally for short periods, not exceeding nine years, and pay fixed rents. The size of farms is from ten to sixty acres; but there are a few of two or three hundred acres. These, however, are chiefly cultivated by the proprietors. Farm-houses are of brick, sometimes stuccoed, and covered with tiles. They are not always detached; but two, three, or more farmeries are often grouped together, and their united buildings might be mistaken for those of one large farm. One side of a square contains the houses of the farmers, the stables, and cattle-sheds; and the three others are sheds, supported by columns, and open on all sides, for implements and produce. The metayers never get rich, and are seldom totally ruined; they are not often changed; the same farm passes from father to son, like a patrimonial estate.



31

266. *Landed property is generally managed by a steward or factor (fattore)*, whose business it is to inspect the cultivation of the lands, to direct repairs, pay taxes and tithes, and see that the landlord has his proper share of the produce. Tithes have been greatly lessened by the sale of a great part of the church lands at the revolution; but are still taken in kind, or commuted for, in order to support the parish clergy. There is no poor-rate here, nor indeed in any part of the world but in Britain.

267. *The irrigation of Lombardy is its most remarkable feature.* The antiquity of the practice has been already noticed (180.) In most states of Italy, the right and property of all rivers; and in some, as Venice, that even of springs and rain, are considered as vested in the king or government. All canals taken from rivers are, therefore, purchased from the state, and may be carried through any person's lands, provided they do not pass through a garden, or within a certain distance of a mansion, on paying the value of the ground occupied. Such canals, indeed, are generally considered as enhancing the value of the property they pass through, by enabling them to purchase water, which is sold by the hour, half-hour, or quarter; or, by so many days' run at certain fixed times, in the year. The right to water from such canals may even be purchased; and Arthur Young mentions that the fee-simple for an hour's run per week, through a sluice of a certain dimension, near Turin, was, in 1788, 1500 livres. The water is not only used for grass-lands, which, when fully watered, are mown four and sometimes five times a year, and in some cases (*e. g. Prato Marcita*) as early as March; but is conducted between the narrow ridges of corn-lands, in the hollows between drilled crops, among vines, or to flood lands, a foot or more in depth, which are sown with rice. It is also used for *combes*, or depositing a surface of mud, in some places where the water is charged with that material; and this is done somewhat in the manner of what we call warping. The details of watering, for these and other purposes, are given in various works; and collected in those of professor Re. In general, watered lands let at one-third higher than lands not irrigated.

268. *The implements and operations of agriculture in Lombardy are both very imperfect.* The plough is of very rude contrivance, with a handle thirteen or fourteen feet long. It is drawn by two oxen without a driver or reins, the ploughman using a long light rod or goad. The names given to the different parts of the plough are corruptions or variations of the Roman terms already mentioned (111.) Corn is generally beaten out by a wheel or large fluted cylinder (*fig. 32.*), which is turned in a circular tract somewhat in the manner of a bark-mill in England.

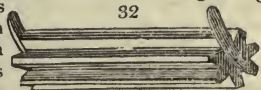

32

269. *The cattle of Piedmont are, in some cases, fed with extraordinary care.* They are tied up in stalls; then bled once or twice; cleaned and rubbed with oil; afterwards combed and brushed twice a day: their food in summer is clover, or other green herbage; in winter a mixture of elm-leaves, clover-hay, and pulverized walnut-cake, over which boiling water is poured, and bran and salt added. Where grains (*pouture*) can be procured, they are also given. In a short time, the cattle cast their hair, grow smooth, round, fat, and so improved as to double their value to the butcher. (*Mem. della Soc. Agr. vol. i. p. 73.*)

270. *The dairies on the plain of the Po, near Lodi, produce the Parmesan cheese. The peculiar qualities of this cheese depend more on the manner of making than on any thing else. The cows are a mixed breed, between the red Hungarian, or Swiss cow, and those of Lombardy. The chief peculiarity in their feeding is, that they are allowed to eat four or five hours in the twenty-four; all the rest of the time they are stalled, and get hay. Both their pasture and hay are chiefly from irrigated lands. The cheeses are made entirely of skimmed milk; half of that which has stood sixteen or seventeen hours, and half of which has stood only six hours. The milk is heated and coagulated in a cauldron (fig. 33.), placed in a very ingenious fire-place, being an inverted semicone in brick-work, well adapted for preserving heat and the use of wood as fuel. Without being taken out of the cauldron, the curd is broken very small by an implement, consisting of a stick with cross wires; it is again heated, or rather scalded, till the curd, now a deposition from the whey, has attained a considerable degree of firmness; it is then taken out, drained, salted, and pressed, and in forty days is fit to put in the cheese-loft. The peculiar properties of this cheese seem to depend on the mode of scalding the curd; though the dairymen pretend that it also depends on the mode of feeding the cows. Where one farmer has not enough of cows to carry on the process himself, it is common for two or more to join and keep a partnership account, as in Switzerland.*

33

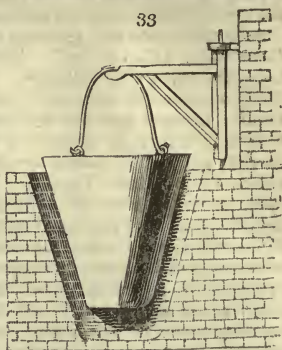

271. *Sheep are not common in Lombardy: there are flocks on the mountains, but in the plains only a few are kept in the manner pigs are in England, to eat refuse vegetables. The Merino breed was introduced, and found not to succeed.*

272. *The rotations of crops are not so remarkable for preserving fertility as for profitable produce, provided a great return is obtained. That, however, is not often the case. As examples, we may mention; 1. maize drilled; 2. 3. and 4. wheat; 5. maize drilled; 6. 7. and 8. wheat. Another is; 1. fallow; 2. 3. and 4. rice; 5. fallow; 6. wheat and clover, &c. Hemp, flax, lupins, rape, millet, panic, rye, and sometimes oats, with other crops, enter into the rotations. Rice is reckoned the most profitable crop; and next, wheat and millet. The rice-grounds receive but one ploughing, which is given in the middle of March, and the seed sown at the end of the same month, sometimes in water up to the seedsman's knees; but more frequently the water is not let on till the rice is come up. The water is then admitted, and left on the ground till the beginning of June, when the crop is weeded by hand, by women half naked, with their petticoats tucked to their waists, wading in the water; and they make so droll a figure, that parties are often made at that season to go and view the rice-grounds. When the weeding is finished, the water is drawn off for eight days, and it is again drawn off when the ear begins to form, till formed; after which it is let in again till the rice is nearly ripe, which is about the end of August or beginning of September. The produce is from ten to twenty fold.*

34



273. *Among the herbage crops cultivated, may be mentioned chicory (fig. 34.), very common in the watered meadows, rib-grass, also very common, oat-grass, and some other grasses; but not nearly the variety of grasses found in the English meadows and pastures; fenugreek (*Trigonella*, L.), clovers, lucerne, saintfoin, and in some places burnet and spurry.*

274. *Among the trees grown by the farmer, the mulberry predominates, and is pollarded once or oftener every year for the silkworm. The tree is common in the hedge-rows, and in rows along with vines parallel to broad ridges. The vine is generally cultivated; trained or rather hung on mulberry, maple, or flowering ash pollards, or climbing up tall elms, or in the hedges, or against willow-poles or rude espalier rails. (fig. 35.) The olive is not very common, but is planted in schistous declivities in warm situations; apple, pear, and greengage plums are common.*

275. *Though the agriculture of Lombardy appears to be practised more for subsistence than for the employment of capital, and the acquisition of riches; yet, from the effect of irrigation in producing large crops of grass, the profits of*



rearing silk, and the rigid economy of the farmers, it is thought by Chateauvieux that it sends more produce to market than any district of Italy. (*Italy, &c. Let. iv.*)

SUBJECT. 2. *Of the Agriculture of Tuscany.*

276. *The picture of the agriculture of Tuscany given by Sismondi, a distinguished literary character of Geneva, who resided five years as a cultivator in that country, is well known. Sismondi arranges the rural economy of this district into that of the plains, the slopes, and the mountains; and we shall here state the most interesting or characteristic circumstances which occur in his work, or that of Chateauvieux, under these heads. According to Forsyth, one half of Tuscany is mountains which produce nothing but timber; one-sixth olive and vine hills, and the remaining third plain. The whole is distributed into eighty thousand fattorie, or stewardships. Each fattorie includes, on an average, seven farms. This property is divided among forty thousand families or corporations. The Riccardi, the Strozzi, the Feroni, and the Benedictines rank first in the number. The clergy keep the farmers well disciplined in faith, and through the terror of bad crops, they begin to extort the abolished tithes. This was in 1802: tithes are again fully established under the Austrian power.*

277. *The climate of Tuscany is esteemed the best in Italy, with the exception of that of its maremme, or pestilential region on the sea-coast. The great heats commence at the end of June, and diminish in the middle of September; the rest of the year is a perpetual spring, and vegetation in the plains is only interrupted for two or three weeks in the middle of winter. On the mountains, there is snow all the year; and the hilly districts enjoy a temperate but irregular weather in summer, and a winter of from one to three months.*

278. *The soil of the plains is either sand or a mud of "inexpressible fertility;" some parts were marshy, but the surface is now comparatively elevated and enriched (as was that of the Delta) by combles, or warping, a process ably described by Sismondi. (*Agr. Tuscan. § ii.*)*

279. *Irrigation in the plains is practised in all the different modes as in Lombardy, but on a smaller scale correspondent with their extent.*

280. *The plain is every where enclosed; the fields are parallelograms, generally one hundred feet broad, and four or five hundred feet long, surrounded by a ditch planted with Lombardy poplars and vines, with rows lengthways, of mulberries, maple or the flowering or manna ash, also interspersed with vines; and often by the way-sides, hanging in festoons, from tall elms (fig. 36.). The poplars supply leaves for feeding heifers, rods which are sold for making espaliers for vines, and spray for fuel. Every now and then a few are cut down for timber, as at twenty years they are found to be too large for the situation. The top of the ash and maple is used for fuel; the timber for implements of husbandry. The mulberry is polarded every other year for the leaves, which are stripped off for the silkworms, and the spray used as fuel. The produce of raw silk is one of the most important in Tuscany, and is almost the only article the farmer of the plains has to exchange for money. He has wine also, it is true, but that, though produced in abundance, is of so wretched a quality, compared with that of the hills, that it brings but little. Hedges are only planted on the road sides to keep off beggars and thieves, who are very numerous, and who steal the grapes and the ears of maize. Sometimes the grapes next the road are sprinkled with mud or lime-water to deter them; at other times a temporary dead fence of thorns is used during the ripening season and taken down afterwards. The hedge plants are the hawthorn, sloe, bramble, briar, evergreen rose, ilex, service, myrtle, pomegranate, bay, laurel, &c.*

281. *In the arable lands of the plains the row and mostly the raised drill-culture is generally followed, or the land is ploughed into beds of three or four feet broad, between which water is introduced in the furrows. Every year a third of the farm is turned over with a spade to double the depth of the plough, so as to bring a new soil to the surface. The sort of trenching which effects this is performed differently from that of any other country; the spade being thrust in horizontally or obliquely, and the trench formed by taking off successive layers from the top of the firm side, and turning them regularly over in the trench. In this way the surface is completely reversed.*

282. *The rotation of crops in the plain includes a period of three or five years, and five or seven crops. There are, for a three-year's course; 1. wheat or other grain, and lupins in the autumn; 2. corn of some sort, and turnips or clover in the autumn; 3. maize, panic, or common millet, and Indian or black millet (*Holcus sorghum*). Corn is cut about the end of June close to the earth, left to dry a day or two, and then tied in bundles (*bottes*), and put in cocks for a week or two. At the end of this period the ears are cut off and beaten out on a smooth prepared piece of ground in the farm-yard. The straw*

36



is stacked, and the corn cleaned by throwing it with shovels, &c. The corn is laid up till wanted in oval excavations in dry ground, which are covered with tiled roofs. The excavations are lined with straw; one holds from twenty to an hundred sacks, and being covered with straw, is heaped over with earth. In this way it is kept in perfect preservation a year or longer, and untouched by insects. The lupins sown after wheat, are often ploughed-in for manure; sometimes French beans are substituted and the ripe seeds used as food, or turnips are sown for cattle. They have few sorts of turnips that are good; and Sismondi complains that half of them never bulb. Maize is sown in drills, and forms a superb crop in appearance, and no less important, constituting the principal food of the lower classes in every part of Italy where the chestnut does not abound. When the male flowers of the maize begin to fade, they are cut off by degrees, so as not to injure the swelling grain; the leaves are also cut off about that time, cattle being remarkably fond of them. In the plain of Bologna, hemp, flax, and beans, enter into the rotation.

283. *Cattle in the plains* are kept constantly in close warm houses, and fed with weeds, leaves, or whatever can be got. The oxen in Tuscany are all dove colored; even those which are imported from other states, are said to change their coat here. They are guided in the team by reins fixed to rings which are inserted in their nostrils; sometimes two hooks, jointed like pincers, are used for the same purpose. In general, only one crop in four is raised for the food of cattle, so that these are not numerous; it may thus appear that manure would be scarce, but the Tuscan farmers are as assiduous in preserving every particle both of human and animal manure as the Flemings.

284. *The farm-houses of the plain of Tuscany*, according to Lasteurie (*Coll. de Mach, &c.*), are constructed with more taste, solidity, and convenience than in any other country on the Continent. They are built of stones generally, in rubble work, with good lime and sand, which becomes as hard as stucco, and they are covered with red pantiles. The elevation (*fig. 37.*) presents two deep recesses, the one a porch or common hall to the ground floor, or husbandry part of the edifice (*a*); and the other above it to the dwelling family apartments. The ground floor consists of this porch, which is arched over (*a*), a work-shop (*b*), a harness and tool-room (*c*), pigstye (*d*), poultry house (*e*), a stove (*f*), staircase (*g*), stable (*h*), cow or ox house (*i*), and sheep house (*k*). The dwelling floor consists of the upper gallery or open hall (*l*), which serves as a sort of kitchen work-room or scullery, a kitchen (*m*), a master and mistress' room (*n*), a girls' room (*o*), and a boys' room (*p*), a store room (*q*), and silk worm room (*r*).

285. *The peasants, or farmers, of the plains* are for the most part metayers; their farms are from five to ten acres, each having a house and offices, like that just described, towards its centre. Some pay a fixed rent on short leases; and some hold farms on improving leases which extend to four generations. They are more than economical; never taste butcher meat but on Sunday. The three repasts of the other days are either of porridge of maize, and a salad; porridge of bread and French beans, seasoned with olive oil; or some sort of soup. In general the whole family remains at home, and aid their parents in performing the labors of the farm. Seldom any but the oldest son marries; and when the father dies he succeeds in his turn, and his brothers and sisters serve him as they did their father till they die off, and are replaced by their nephews and nieces. Such is the state of things which, as Châteaueux has observed, is the result of early civilization and excessive population.

37

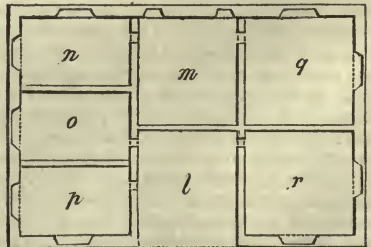
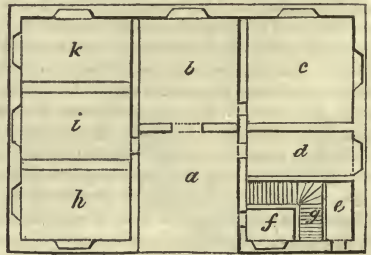



286. *The culture of the hills and declivities*, Chateauvieux supposes to have been introduced from Canaan at the time of the crusades. But though that culture, and also the irrigation system, have, no doubt, been originally copied from that country and Egypt; yet some think it more likely to have been imported by the Romans or the priests, than by the chivalric adventurers of the eleventh and twelfth centuries.

287. *The soil of the hills* is in general either schistous or calcareous on a pliable rocky or gravelly bottom. It is cut into horizontal terraces of different widths according to the steepness of the declivity, and each terrace is supported by a wall or sloping bank of turf or stones. Intercepting gutters are formed every sixty or seventy feet in the direction of the slope to carry off the waters which do not sink in the rainy season. Sismondi considers the turfed terraces of the hills of Nievole (*fig. 38.*) the most elegant. On the

38



terraces of the most rapid and least favorably exposed slopes, olives are planted; on the best exposure, vines. Where the terrace is broad, one or more rows of mulberries, and sometimes of fig trees, are planted, and between these, where the soil is not too dry, early crops of grain or legumes are taken. The walls of turf are mown.

288. *The olive* being an evergreen and in a state of growth all the year, requires a more equable climate than the vine; but it will grow on any dry soil, and in an inferior exposure, because the fruit never ripens till the hoarfrosts have commenced. The young plants are raised from cuttings or suckers in a nursery, and in the same manner in which it was during the time of the Romans. "An old tree is hewn down, and the 'ceppo' or stock (that is, the collar or neck between the root and the trunk, where in all plants the principle of life more eminently resides,) is cut into pieces of nearly the size and shape of a mushroom, and which from that circumstance are called 'novali;' care at the same time is taken that a small portion of bark shall belong to each 'novalo;' these, after having been dipped in manure, are put into the earth, soon throw up shoots, are transplanted at the end of one year, and in three years are fit to form an olive yard." (*Blunt's Vestiges, &c.* 216.) They are planted in rows generally fifteen feet apart, and the same distance between the rows.

289. *The olive is of very slow growth but of great duration.* Some plantations exist, which are supposed to be those mentioned by Pliny, and therefore must have existed nearly two thousand years, if not more. In one of these, which we have seen in the vale of Marmora near Terni, the trunks of many trees have rotted at the core, and the circumference split open and formed several distinct stems. Though in ruins, these trees still bear abundant crops. The olive requires little pruning, and is seldom otherwise manured than by sowing lupins under it, and digging them in. The fruit becomes black in November; is gathered in the course of that and the three following months; and ground in a stone trough by a stone turned by a water-wheel. The paste formed by the fruit, and its kernels, is then put in a hair cloth and pressed, and the oil drops in a tub of water somewhat warm, from which it is skimmed and put in glass bottles for sale, or glazed jars for home consumption. The paste is moistened and pressed a second and third time for oils of inferior quality. The crop of olives is very uncertain; sometimes one that yields a profit does not occur for six or eight years together, as in the culture of wine and cider: and these departments of culture on the Continent are considered as injurious to the peasant, because in the year of plenty he consumes his superfluous profits without laying any thing aside to meet the years of loss. Hence the remark common in France and Italy, that wine and oil farming is less beneficial than that of corn.

290. *The vine on the hills* is generally raised where it is to remain by planting cuttings; but it is also planted with roots procured by layering: in either case, it seldom bears fruit till the fifth year after planting. It is trained on trees, poles, and trellised roofs, over paths, and different kinds of espalier rails. The poles are of barked chestnut, and the lesser rods used are generally of reeds (*Arundo donax*, L.), the latter forms a profitable article of culture on the brink of water-courses for this purpose. These reeds last from one to four years, according to their size. The ties made use of both in the hills and plains are of willow, often the yellow or golden sort. The general maxim in pruning is to leave as much wood to a single root as possible, in order to prevent two shoots from proceeding from one eye, in which case both are generally barren. They give no summer pruning; but when the fruit is nearly ripe, they cut off the extremities of the shoots for the sake of the leaves as forage, and to admit the sun and air more directly to the fruit. The pruning hook they use (fig. 39.) is not unlike a hand-hedgebill. The fruit is gathered by women, and put into baskets and hampers; carried to a tub or cistern of masonry, where it lies and ferments, being frequently stirred, but not pressed, as in France and other parts of Italy. The management of the wine is not considered good; and there are but few sorts of Tuscan wine that will keep above a year.



291. *The potatoe*, little known in Lombardy, was introduced in the hills of Tuscany by Sismondi, but was little cultivated or esteemed. It is only known, he says, to the gardeners of Florence and Leghorn. If not taken up about the middle of July the tubers are either burned and rotted by the heat, or they germinate at every bud. An early sort, he thinks, might be introduced both in the plain and hill culture with great advantage.

292. *The hill farmers*, like those of the plains, are generally metayers, and rent their farms, which seldom exceed seven or eight acres; and the most general conditions of their lease (bail), according to Mr. Simonds, are the following: 1. The farmer engages to cultivate the lands, and find the requisite props for the vines. 2. To advance the half of the seed, and the half of the dung that is obliged to be purchased. 3. To deliver to the proprietor half the crop, or sell it for his account. 4. To divide with the proprietor the profit made on cattle, and to deliver a certain number of eggs, chickens, and capons in lieu of that on poultry. 5. To wash the whole or a part of the proprietor's linen, he finding soap. The proprietor on his part engages to advance the other half of the seed, and of the manure which must be purchased; to be at the expence of making up new grounds and other radical improvements, to effect repairs, &c., and to find the first props for newly planted vines. This contract goes on from year to year, and can only be dissolved by a year's notice; changes, however, very seldom take place. The conditions in some places are more severe for the farmer; and on oil and certain other articles he only recovers a third of the profits.

293. *The culture of the mountains of Tuscany* consists of the harvesting of chestnuts, the management of live stock, and of forests. The chestnut trees, Sismondi is of opinion, have been originally planted, but they now receive no other care than that of replacing a worn-out tree by a young one, and cutting out dead wood, which is done more for the sake of fuel than any thing else. The fruit is gathered in November, after it drops on the turf: it is eaten either in its natural state, or it is ground into meal and prepared as flour. Such as are to be ground, are first kiln dried; next, the chestnuts are put into small bags, which hold half a bushel each, and these are beat against the ground till the outer husk is removed; they are then taken out, the outer husks separated, and the chestnuts replaced, and beat as before till the inner husk comes off; they are then cleaned in the wind, and sent to a corn-mill to be ground. The flour they produce has no bran, and is mild and sweet, and keeps well. Lands covered with chestnuts are valued not by their extent, but by the number of sacks of fruit annually produced. Chestnut flour is chiefly used in the form of porridge or pudding. In the coffee houses of Lucca, Pescia, and Pistoia, patés, muffins, tarts, and other articles are made of it, and are considered delicate.

294. *The culture of sheep in the mountains* is rude and unprofitable, and so little is mutton esteemed in Tuscany that it always sells at two or three sous a pound under every other meat. The sheep are pastured all the summer under the chestnut trees; but in October, when the fruit begins to fall, they are then sent to the maremmes, where they remain till the May or June following, at the cost of not more than a penny a head. A wretched cheese is made from the milk; but bad as it is, it is better than what is made from the milk of goats or cows. The Tuscans, indeed, are so averse to believe that good cheese can be produced from the latter animals, that they consider the Dutch and other excellent foreign cheeses which they purchase at Leghorn, as all made from the milk of sheep.

295. *Forests of timber trees cover the highest parts of the mountains.* From these the peasants derive their sources of profit, independently of the sale of timber, which is very limited, owing to the difficulty of carriage. Hogs are pastured there, left to themselves

the whole year, and only sought for when wanted for the butcher. Their flesh is excellent, and being very abundant in the markets of most parts of Italy, is not dear. Acorns are collected in some places, and sold to the farmers of the plains for feeding swine. The cones of the *Pinus pinea* (fig. 40.) are collected, and the seeds taken out: these are much esteemed, and bear a high price. The same thing is, in some places, done with the cones of the wild pine, commonly but erroneously called the Scotch fir (*Pinus sylvestris*, L.), whose seeds are equally good, though smaller. Strawberries, bramble berries, gooseberries, currants, raspberries, and other wild fruits, are collected and either sold publicly in the markets of the plains, or privately to the confectioners for flavoring ices; an article in great demand throughout all Italy. Sismondi seems to have been the first who noticed that the black mulberry was grown in the mountains for its leaves, being considered as hardier than the white. The fruit was only eaten by children. In the plains and gardens of Italy the mulberry is scarcely known as a fruit tree, though the white species is every where grown for the silkworm.

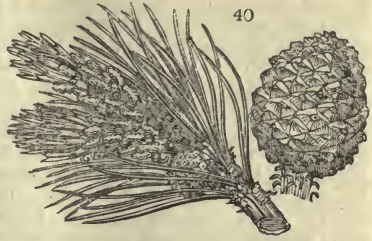

296. *The mountain farmers* are generally proprietors of their farms. They live together in villages, which are very numerous; many of them hire themselves to the farmers of the maremmes when there is a scarcity of population, to assist in their harvests; and with the money saved in this way, and by sending fruits, collected by their wives and children, to the towns in the plains, they are generally better off than the farmers of the hills, or of the low country.

297. *The agricultural establishment of Rossore* may be mentioned as belonging to Tuscany. It is situated at the gate of Pisa, and was founded by the family of Medici, in the time of the crusades, and now belongs to government. A league square of ground, which was so poor and sandy as to be unfit for culture, was surrounded by a fence, and having been left to itself, has now the appearance of a neglected park. A building was erected in its centre as a lodge, and interspersed in the grounds were built stables and sheep houses. The park was stocked with an Arabian stallion and a few mares, and some Asiatic camels; and these were left to breed and live in a state of nature. About the beginning of the present century a flock of Merino sheep was added. The horses have formed themselves into distinct tribes or troops, each of fifteen or twenty mares governed by a stallion. These tribes never mix together, each has its quarter of pasture which they divide among themselves without the interference of shepherds. The shape of these horses is wretched, and the spare or superfluous ones are sold only to fuel drivers (coalmen, *Carbonari*), and the post. There are more than two hundred camels which associate together, and multiply at pleasure. They are worked in the plough and cart, and the spare stock supplies all the mountebanks of Europe, who buy them at the low price of six or seven louis each. The next feature of this establishment is a herd of 1800 wild bulls and cows, fierce and dangerous: the superfluous stock of these is either hunted and killed for their hides and flesh, or sold alive to the farmers to be fed or worked. The flock of Merinos are but lately introduced. Such are the chief features of this establishment; which Chateaubvieux terms a specimen of Tatar culture: it is evident it has no other art or merit than that of allowing the powers and instincts of nature to operate in their own way: it forms a very singular contrast to the highly artificial state of rural economy in Tuscany.

SUBJECT. 3. *Of the Agriculture of the Maremmes, or the District of Pestilential Air.*

298. *The extent of this district* is from Leghorn to Terracina in length; and its widest part is in the states of the church; it includes Rome, and extends to the base of the Appennines.

299. *The climate of the maremmes* is so mild that vegetation goes on during the whole of the winter; but so pestilential that there are scarcely any fixed inhabitants in this immense tract of country, with the exception of those of the towns or cities on its borders.

300. *The surface* is flat or gently varied; and the soil in most places deep and rich. In the maremmes of Tuscany it is in some places a blue clay abounding in sulphur and alum, and produces almost nothing but coltsfoot (*tussilago*).

301. *The estates* are generally extensive, and let in large farms at fixed rents, to men of capital. The maremmes of Rome, forty leagues in extent, are divided only into a few hundred estates, and let to not more than eighty farmers. These farmers grow corn, and pasture oxen of their own; and in winter they graze the wandering flocks of the mountains of Tuscany and other states as so much a head. The corn grown is

chiefly wheat, which is reaped by peasants from the mountains, some of whom also stay and assist in sowing the succeeding crop; whence, the whole disappear; and the marmemes remain a desert with a few men, whom Chateauvieux designates as "half savages, who run over these solitudes like Tatars, armed with long lances, and covered with coarse woollens and untanned skins." The lance they use in hunting down the oxen when any are to be caught for the butcher, or to break-in for labor; and the clothing alluded to has been recommended by the medical men of Rome, as the most likely to resist the attacks of the malaria (bad air), or pestilence.

302. *The agricultural implements and operations* differ little from those of other parts of Italy. The plough, or araire, of Rome (fig. 41.), is a rude implement, with a broad flat share, on the hinder end of which the ploughman stands; and thus drawn along, his weight makes a deeper furrow. Two strips of wood (the *binæ auris* of Virgil), about eighteen inches long, are often attached to the share, diverging a little from each other, and these serve to lay open the furrow like our mould-board. In the operation of propagating the vine, cuttings are planted in trenches four feet deep, into which stones have been previously thrown, for the alleged purpose of encouraging moisture about the roots. The same mode was practised in

Virgil's time. (*Georg.* ii. 346.) The common Roman cart (fig. 42.), is supposed to have been originally designed by the celebrated

Michael Angelo, in his quality of engineer and wheeler. — *Bonarotti*. (See *Lasteyrie, Col. des Mah. &c.*)

303. *The farm of Campo Morto* (field of death) includes the whole property of St. Peter's church in Rome, which is supported from its sole revenue. This vast estate is situated in the Pontine marshes, and the following outline of its management is taken from a letter of Chateauvieux, written in July 1813: —

304. *The farmery*, the only building on an estate of many thousand acres, consists of a central building and two wings, the ground-floor of the central part consists of an immense kitchen and five large rooms, the latter without windows, and unfurnished. The first story consists of six rooms, used as corn-chambers, with the exception of one, which was furnished, and served to lodge the principal officers. The two wings contained large vaulted stables, with hay-lofts over. One female lived in the house, in order to cook for the officers or upper servants, whose wives and families live in the towns as do those of the shepherds. There was no garden, or any appearance of neatness or cleanliness, and not a fence or a hedge, and scarcely a tree on the whole farm.

305. *The fattore, or steward*, was an educated man, and a citizen of Rome, where his family lived; he and all the other officers, and even shepherds, always went out mounted and armed.

306. *The reapers* were at work in a distant part of the estate, when Chateauvieux went over it: they were an immense band, ranged as in the order of battle, and guarded by twelve chiefs or overseers on horseback, with lances in their hands. These reapers had lately arrived from the mountains; half were men and the rest women. "They were bathed in sweat; the sun was intolerable; the men were good figures, but the women were frightful. They had been some days from the mountains, and the foul air had begun to attack them. Two only had yet taken the fever; but they told me, from that time a great number would be seized every day, and that by the end of harvest the troop would be reduced at least one half. What then, I said, becomes of these unhappy creatures? They give them a morsel of bread, and send them back. But whither do they go? They take the way to the mountains; some remain on the road, some die, but others arrive, suffering under misery and inanition, to come again the following year."

307. *The corn is threshed* fifteen days after being cut: the grain is trodden out under the feet of horses, cleaned, and carried to Rome. The straw was formerly suffered to be dispersed by the wind; but it is now collected in heaps at regular distances over the country, and always on eminences; there it lies ready to be burned on the approach of "those" clouds of grasshoppers which often devastate the whole of this country."

308. *The live stock of the farm* consisted of a hundred working oxen; several hundreds of wild cows and bulls kept for breeding, and for the sale of their calves and heifers; two thousand swine, which are fattened by nuts and acorns in the forests belonging to the estate; a hundred horses for the use of the herdsmen. There were four thousand sheep on the low grounds, and six hundred and eighty thousand on the mountains belonging to the estate. Of the latter, eighty thousand were of the Negretti breed, whose wool it was intended to have manufactured into the dresses of all the mendicant monks in Italy, and into the great-coats of the shepherds: the rest were of the Pouille breed, which produces a white wool, but only on the upper part of the body. As mutton is not good, and but little eaten in Italy, they kill most of the tup-lambs as soon as they are born, and milk the ewes to make cheese. The temporary flocks had not arrived when Chateauvieux was at Campo Morto, the fields not being then cleared of their crops.

309. *The farmer of this extensive domain* is M. Trucci, who pays a rent for it of 22,000 piastres (4950*l.*). This, said M. Trucci to Chateauvieux, "supposes an extent of three thousand rubbi, or six thousand acres, of cultivable land. I have nearly as

41

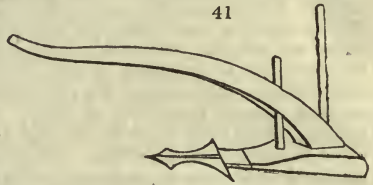

42

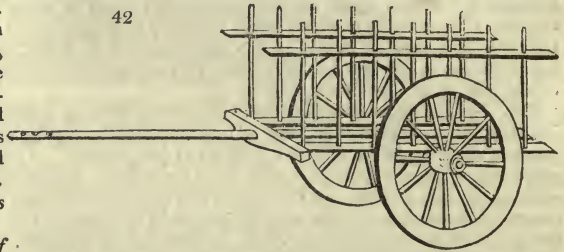

much that is not fit for the plough, and it is there my pigs and my cows principally feed. My three thousand rubbi are divided into nearly nine equal parts of three hundred and thirty rubbi each: one of these is in fallow, another in corn, and the seven others in pasture. On the two thousand three hundred rubbi, which remain in grass, I support four thousand sheep, four hundred horses, two hundred oxen, and I reserve a portion for hay. In the *macchie* (bushy places, woody wastes) I have seven hundred cows, and sometimes nearly two thousand pigs.

310. *My expenses* "are limited to paying the rent of the farm, to purchasing bread for the workmen, and to the entire maintenance of my army of shepherds, superintendants, and the fattore; to paying for the work of the day-laborers, of the harvest-men, &c.; and, in short, to the expense of moving the flocks, and to what, in large farms, is called the extra charges, the amount of which is always very high. There must also be deducted from the gross profits of the flock about one-tenth, which belongs, in different proportions, to my chiefs and to my shepherds, because I support this tenth at my expense. We have also, in this mode of culture, to sustain great losses on our cattle, notwithstanding which I must acknowledge that our farming is profitable.

311. *Of annual profit*, "I average about five thousand piastres, besides five per cent. on the capital of my flocks. You see, then, that the lands in the Campagna of Rome, so despised, and in such a state of wildness, let at the rate of eighteen francs (fifteen shillings) the Paris acre: there is an immense quantity in France, which does not let for so much. They would, doubtlessly, let for more if they were divided and peopled, but not in the proportion supposed, for the secret in large farms consists in their economy; and nothing on the subject of agricultural profit is so deceptive as the appearance they present to our view, for the profit depends solely on the amount of the economical combinations, and not on the richness of the productions displayed to the eye." (*Letters on Italy, &c.*)

#### SUBJECT. 4. *Farming in the Neapolitan Territory, or the Land of Ashes.*

312. *The farming on the volcanic soil*, in the neighborhood of Vesuvius, belongs to the valley farming of Tuscany; but as it varies a little, and as the farmers are much more wretched, we shall give the following relation, as received by Chateauvieux, from a Neapolitan metayer:—

313. *We, poor metayers*, he said, "occupy only so much land as we can cultivate by our own families, that is to say, four or five acres. Our condition is not a good one, since we get for our trouble only a third of the produce, two-thirds belonging to the owner, which we pay in kind into the hands of the steward. We have no ploughs, and the whole is cultivated by the spade. It is true that the soil, being mixed with ashes, is easily stirred; and even our children assist us in this work. At times the mountain, hence named Vesuvius, pours forth showers of ashes, which spread over our fields and fertilize them.

314. *The trees* which you see on the land, "are not without their use; they support the vine, and give us fruit; we also carefully gather their leaves: it is the last autumnal crop, and serves to feed our cattle in the winter. We cultivate, in succession, melons, between the rows of elms, which we carry to the city to sell; after which we sow wheat. When the wheat crop is taken off, we dig in the stubble, which is done by our families, to sow beans or purple clover. During six months, our children go every morning to cut a quantity of it with the sickle, to feed the cows. We prefer the females of the buffaloes, as they give most milk. We have also goats, and sometimes an ass, or a small horse, to go to the city and carry our burthens; but this advantage belongs only to the richer metayers.

315. *We plant the maize* "the following spring, after clover or beans. We manure the land at this time, because this plant is to support our families; this crop, therefore, interests us more than all the others, and the day in which it is harvested is a day of festivity in our country. All the villagers assemble together, the young women dance, and the rest of us walk slowly, being laden with our tools: arrived at our dwellings, each family goes into its own; but they are so near each other, that we can still converse together.

316. *We often gather seven ears from one stalk of maize*, "and many of them are three palms long. When the sun is high, the father of the family goes into the adjoining field to get some melons, while the children gather fruit from the surrounding fig-trees. The fruit is brought under an elm-tree, round which the whole family sits; after this repast the work begins again, and does not cease until the close of day. Each family then visits its neighbors, and tells of the rich crop the season has bestowed upon them.

317. *We have no sooner gotten in the maize than the earth is again dug, to be sown once more with wheat*; after this second crop, we grow in the fields only vegetables of different kinds. Our lands thus produce wine and fruit, corn and vegetables, leaves and grass for the cattle. We have no reason to complain of their fertility; but our conditions are hard, little being left for our pains; and if the season is not propitious, the metayer has much to complain of." (*Letters, &c.*)

318. *The cotton plant (Gossypium herbaceum) (fig. 43.)* is beginning to be cultivated in the neighborhood of Vesuvius, and in Sicily. It is sown in March, in lines at three feet distance, and the plants two feet apart in the lines. The earth is stirred by a one-horse plough, or by hoes, and carefully weeded. As soon as the flowering season is over, about the middle of September, the ends of the shoots are nipped off, to determine the sap to the fruit. The capsules are collected as they ripen; a tedious process, lasting two months: the cotton and the seeds are then separated; an operation still more tedious. The most extensive cotton farmers are in the vale of Sorrento. There the rotation is, 1. maize; 2. wheat, followed by beans, which ripen next March; 3. cotton; 4. wheat, followed by clover; 5. melons, followed by French or common beans. Thus, in five years, are produced eight crops. In this district, wherever water can be commanded, it is distributed, as in Tuscany and Lombardy, among every kind of crop.



319. *The tomato, or love apple (Solanum lycopersicum, L.),* so extensively used in Italian cookery, forms also an article of field-culture near Pompeii, and especially in Sicily, from whence they are sent to Naples, Rome, and several towns on the Mediterranean sea. It is treated much in the same way as the cotton plant.

320. *The orange, lemon, peach, fig, &c.,* with various other fruits, are grown in the Neapolitan territory, both for home use and exportation: but their culture we consider as belonging to gardening.

321. *The Neapolitan maremmes, near Salerno,* to the evils of those of Rome, add that of a wretched soil. They are pastured by a few herds of buffaloes and oxen; the herdsmen of which have no other shelter during the night than reed huts; these desert tracts being without either houses or ruins. The plough of this ancient Greek colony is thought to be the nearest to that of Greece, and has been already adverted to (24.)

322. *The manna, a concrete juice,* forms an article of cultivation in Calabria. This substance is nothing more than the exsiccated juice of the flowering ash-tree (*Ornus rotundifolia*), which grows there wild in abundance. In April or May, the peasants make one or two incisions in the trunk of the tree with a hatchet, a few inches deep; insert a reed, round which the sap trickles down, and after a month or two they return, and find this reed sheathed with manna. The use of manna, in medicine, is on the decline.

323. *The filberts and chestnuts* of the Calabrian Appennines are collected by the farmers, and sold in Naples for exportation or consumption.

324. *The culture of indigo and sugar* was attempted in the Neapolitan territory, under the reign of Murat. The indigo succeeded; and time had not elapsed to judge of the sugar culture when it was abandoned. The plants, however, grew vigorously, and their remains may still (1819) be seen in the fields near Terracina.

325. *Oysters have been bred and reared in the kingdom of Naples* from the time of the Romans. The subject is mentioned by Nonnius (*De Reb. Cib.* l. iii. c. 37.); and by Pliny, (*Nat. Hist.* b. xviii. c. 54.) Count Lasteyrie (*Machines, &c.*) describes the place mentioned by the latter author, as it now exists in the lake Facino, at Baia. This lake (*fig. 44.*) communicates with the sea by a narrow passage: on the water near its mar-

44

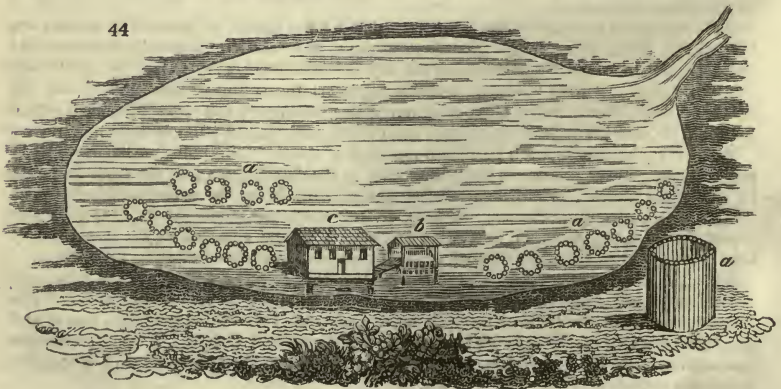

gin, a house (c) is constructed for those who take care of the oysters, and who sell them to the dealers in Naples, or to those who come and eat them on the spot. Adjoining the house is a covered enclosure (b), where the oysters are kept till wanted; and along the margin of the lake, and in most parts of it, are placed circles of reeds, with their summits above the water (a). The spawn of the oysters attaches itself to these reeds, and grows there till of an edible size: they are then removed to the reserve (b), and kept there till wanted. In removing them the reeds are pulled up one by one, examined, and the full-grown oysters removed and put in baskets, while the small sized and spawn are suffered to remain, and the reed is replaced as it was. The baskets are then placed in the reserve, and not emptied till sold. In two years from the spawn, Lasteyrie observes, the oyster is fully grown.

## SECT. II. *Of the present State of Agriculture in Switzerland.*

326. *The agriculture of Switzerland*, though of a very primitive kind, is not without interest from the nice attentions required in some parts of its operations. The surface, soil, and climate of the country, are so extraordinarily irregular and diversified, that in some places grapes ripen, and in many others corn will not arrive at maturity; on one side of a hill the inhabitants are often reaping, while they are sowing on the other; or they are obliged to feed the cattle on its summits with leaves of evergreens while they are making hay at its base. A season often happens in which rains during harvest prevent the corn from being dried, and it germinates, rots, and becomes useless; in others it is destroyed by frost. In some cases there is no corn to reap from the effect of summer storms. In no country is so much skill required in harvesting corn and hay as Switzerland; and no better school could be found for the study of that part of Scotch and Irish farming. After noticing some leading features of the culture of the cantons which form the republic, we shall cast our eye on the mountains of Savoy.

### SUBJECT. 1. *Of the Agriculture of the Swiss Cantons.*

327. *Agriculture began to attract public attention in Switzerland* about the middle of the eighteenth century. In 1759 a society for the promotion of rural economy established itself at Berne: they offered premiums and have published some useful papers in several volumes. Long before that period, however, the Swiss farmers were considered the most exact in Europe. (*Stanyan's Account of Switzerland in 1714.*) Chateavieux attributes the progress which agriculture has made, near Vevay, on the lake of Geneva, to the settlement of the protestants, who emigrated thither from France, at the end of the seventeenth century. They cut the hills into terraces, and planted vines, which has so much increased the value of the land, that what was before worth little, now sells at 10,000 francs per acre. (*Let. xxi.*) Improvement in Switzerland is not likely to be rapid; because agriculture there is limited almost entirely to procuring the means of subsistence, and not to the employment of capital for profit.

328. *Landed property in Switzerland* is minutely divided, and almost always farmed by the proprietors and their families: or it is in immense tracts of mountain belonging to the bailiwicks, and pastured in common: every proprietor and burgess having a right according to the extent of his property. These peasants are, perhaps, the most frugal cultivators in Europe: they rear numerous families, a part of which are obliged to emigrate, because there are few manufactures; and land is excessively dear, and seldom in the market.

329. *The vallies of the alpine regions of Switzerland* are subject to very peculiar injuries from the rivers, mountain-rocks, and glaciers. As the rivers are subject to vast and sudden inundations, from the thawing of the snow on the mountains, they bring down at such times an immense quantity of stones, and spread them over the bottoms of the vallies. Many a stream, which appears in ordinary times inconsiderable, has a stoney bed of half a mile in breadth, in various parts of its course; thus a portion of the finest land is rendered useless. The cultivated slopes at the base of the mountains are subject to be buried under *eboulements*, when the rocks above fall down, and sometimes cover many square miles with their ruins.

330. *Eboulement* (Fr.), denotes a falling down of a mountain or mass of rock, and consequent covering the lower grounds with its fragments; when an immense quantity of stones are suddenly brought down from the mountains by the breaking or thawing of a glacier, it is also called an *eboulement*. (*Bakewell, vol. i. p. 11.*) Vast *eboulements* are every year falling from the enormous precipices that overhang the valley of the Rhone: many of these are recorded which have destroyed entire villages.

331. *One of the most extraordinary eboulements ever known* was that of Mont Grenier, five miles south of Chamberry. A part of this mountain fell down in the year 1248, and entirely buried five parishes, and the town and church of St. André. The ruins spread over an extent of about nine square miles, and are called *les Abymes de Myans*. After a lapse of so many centuries, they still present a singular scene of desolation. The catastrophe must have been most awful when seen from the vicinity; for Mont Grenier is almost isolated, advancing into a broad plain, which extends to the valley of the Isere.

332. *Mont Grenier rises very abruptly upwards of 4000 feet above the plain*. Like the mountains of Les Echelles, with which it is connected, it is capped with an immense mass of limestone strata, not less than 600 feet in thickness, which presents on every side the appearance of a wall. The strata dip gently to the side which fell into the plain. This mass of limestone rests on a foundation of softer strata, pro-

bably molasse. Under this] molasse are distinctly seen thin strata, probably of limestone, alternating with soft strata. There can be little doubt that the catastrophe was caused by the gradual erosion of the soft strata which undermined the mass of limestone above, and projected it into the plain; it is also probable that the part which fell had for some time been nearly detached from the mountain by a shrinking of the southern side, as there is at present a rent at this end, upwards of two thousand feet deep, which seems to have cut off a large section from the eastern end, and that now "Hangs in doubtful ruins o'er its base," as if prepared to renew the catastrophe of 1248.

333. *Avalanches* (avalas, or *swallows*), or falls of immense masses of snow from the mountains, often occasion dreadful effects. Villages are overwhelmed by them; and rivers, stopped in their course, inundate narrow vallies to a ruinous extent. In February 1820, the village of Obergestelen, with eighty-eight of its inhabitants, were overwhelmed by an avalanche.

334. *The glaciers*, or ice-hills, or ice-heaps, slide down into the mountain vallies, and form dams across them, which produce large lakes; by the breaking up of the glacier, these lakes are sometimes suddenly poured into the lower vallies, and do immense mischief. Man, in such a country, as Bakewell has observed, is in a constant state of warfare with the elements, and compelled to be incessantly on his guard against the powers that threaten his destruction. This constant exposure to super-human dangers is supposed to have given the aged inhabitants, especially of the Vallais, an air of uncommon seriousness and melancholy.

335. *The Swiss cottages* are generally formed of wood, with projecting roofs, covered with slates, tiles, or shingles. A few small enclosures surround or are contiguous to them, some of which are watered meadows, others dry pasture; and one or more is always devoted to the raising of oats, some barley, and rye, or wheat, for the family consumption. In the garden, which is large in proportion to the farm, are grown hemp, flax, tobacco, potatoes, white beet to be used as spinach and asparagus, French beans, cabbages, and turnips. The whole has every appearance of neatness and comfort. There are however some farmers who hire lands from the corporate bodies and others at a fixed rent; or on the metayer system; and in some cases both land and stock are hired; and peasants are found who hire so many cows and their keep, during a certain number of months either for a third or more of the produce, or for a fixed sum.

336. *The villages of Switzerland* are often built in lofty situations, and some so high as 5000 feet above the level of the sea. "In a country where land is much divided, and small proprietors cultivate their own property on the mountains, it is absolutely necessary that they should reside near it, otherwise a great part of their time and strength would be exhausted in ascending and descending, as it would take a mountaineer four hours in each day, to ascend to many of these villages and return to the valley. In building their houses on the mountains, they place them together in villages, when it can be done, and at a moderate distance from their property, to have the comforts of society, and be more secure from the attack of wolves and other wild animals. Potatoes and barley can be cultivated at the height of 4500 feet in Savoy, and these, with cheese and milk, and a little maize for porridge, form the principal part of the food of the peasantry. The harvest is over in the plains by the end of June, and in the mountains by the end of September. Several of the mountain villages, with the white spires of their churches, form pleasing objects in the landscape, but on entering them the charm vanishes, and nothing can exceed the dirtiness and want of comfort which they present, except the cabins of the Irish." (*Bakewell's Travels*, vol. i. 270.) Yet habit, and a feeling of independence, which the mountain peasant enjoys, under almost every form of government, makes him disregard the inconveniences of his situation and abode. Damsels and their flocks form pleasing groups at a distance, but the former viewed near, bear no more resemblance to *les bergeres des Alpes* of the poets, than a female Hot-tentot to the *Venus de Medicis*.

337. *The vine* is cultivated in several of the Swiss cantons on a small scale; and either against trellises, or kept low and tied to short stakes as in France. The grapes seldom ripen well, and produce a very inferior wine. The best in Switzerland are grown in the Pays de Vaud round Vevy. They are white, and Bakewell says, "as large and fine-flavored as our best hot-house grapes." The physicians at Geneva send some of their patients here during the vintage, to take what is called a regular course of grapes; that is, to subsist for three weeks entirely on this fruit, without taking any other food or drink. In a few days a grape diet becomes agreeable, and weak persons, and also the insane, have found great relief from subsisting on it for three or four weeks. (*Bakewell's Travels*, &c. ii. 206.)

338. *Of fruit trees*, the apple, pear, cherry, plum, and walnut, surround the small field or fields of every peasant. The walnut tree also lines the public roads in many places, and its dropping fruit often is the only food of the mendicant traveller.

339. *The management of woods and forests* forms a part of Swiss agriculture. The herbage is pastured with sheep and swine as in Italy; the copse wood and lop are used for fuel, as in all countries; and when a mode of conveyance and a market can be found the timber is sold, but in many places neither is the case. A singular construction was erected for the purpose of bringing down to the lake of Lucerne the fine pine trees which grow upon Mount Pilatus, by the engineer Rupp. The wood was purchased by a company for 3000*l.*, and 9000*l.* were expended in constructing the slide. The length of the slide is about 44,000 English feet, or about eight miles and two furlongs; and the difference of level of its two extremities is about 2600 feet. It is a wooden trough,



about five feet broad and four deep, the bottom of which consists of three trees, the middle one being a little hollowed; and small rills of water are conducted into it, for the purpose of diminishing the friction. The declivity, at its commencement, is about  $22\frac{1}{2}^{\circ}$ . The large pines, with their branches and boughs cut off, are placed in the slide, and descending by their own gravity, they acquire such an impetus by their descent through the first part of the slide, that they perform their journey of eight miles and a quarter in the short space of six minutes; and, under favourable circumstances, that is, in wet weather, in three minutes. Only one tree descends at a time, but, by means of signals placed along the slide, another tree is launched as soon as its predecessor has plunged into the lake. Sometimes the moving trees spring or bolt out of the trough, and when this happens, they have been known to cut through trees in the neighborhood, as if it had been done by an axe. When the trees reach the lake they are formed into rafts, and floated down the Reuss into the Rhine.

340. *Timber is also floated down mountain torrents from a great height.* The trees are cut down during summer and laid in the then dry bed of the stream: with the first heavy rains in autumn they are set in motion, and go thundering down among the rocks to the valleys, where what arrives sound is laid aside for construction, and the rest is used as fuel.

341. *The chamois abound in some of the forests,* and are hunted for their fat, flesh, and for their skins, which are valuable as glove and breeches leather. They herd in flocks, led by a female; live on lichens and on the young shoots and bark of pines, are remarkably fond of salt, and require great caution in hunting. (*Simond's Switzerland*, vol. i. p. 245.) The common goat is frequently domesticated for the sake of its milk, and may be seen near cottages, curiously harnessed (*fig. 45.*) to prevent its breaking through, or jumping over fences.

45



342. *The Swiss dairy is famous for its Gruyère cheese,* so named after a valley, where the best of that kind is made. Its merit depends chiefly on the herbage of the mountain pastures, and partly on the custom of pressing the flowers or bruised seeds of *Melilotus officinalis* (*fig. 46.*), with the curd before it is pressed. The mountain pastures are rented at so much per cow's feed from the 15th of May to the 18th of October; and the cows are hired from the peasants at so much for the same period. On the precise day both land and cows return to their owners. It is estimated that 15,000 cows are so grazed, and 30,000 cwt. of cheese made fit for exportation, besides what is reserved for home use.

343. *The establishment at Hofwyl, near Berne,* may be considered as in great part belonging to agriculture, and deserves to be noticed in this outline. It was invented, and is conducted at the sole expense of M. Fellenberg, a proprietor and agriculturist. His object was to apply a sounder system of education for the great body of the people, in order to stop the progress of error and corruption. Upwards of twelve years ago he undertook to systematize domestic education, and to shew on a large scale how the children of the poor might be best taught, and their labor at the same time most profitably applied; in short, how the first twenty years of a poor man's life might be so employed as to provide both for his support and his education. The peasants in his neighborhood were at first rather shy of trusting their children for a new experiment; and being thus obliged to take his pupils where he could find them, many of the earliest were the sons of vagrants, and literally picked up on the highways: this is the case with one or two of the most distinguished pupils.

46



344. *Their treatment is nearly that of children under the paternal roof.* They go out every morning to their work soon after sun rise, having first breakfasted, and received a lesson of about half an hour: they return at noon. Dinner takes them half an hour, a lesson of one hour follows; then to work again till six in the evening. On Sunday the different lessons take six hours instead of two; and they have butcher meat on that day only. They are divided into three classes, according to age and strength; an entry is made in a book every night of the number of hours each class has worked, specifying the sort of labor done, in order that it may be charged to the proper account, each particular crop having an account opened for it, as well as every new building, the live stock, the machines, the schools themselves, &c. &c. In winter, and whenever there is not out-of-doors' work, the boys plait straw for chairs, make baskets, saw logs with the cross-saw and

split them, thrash and winnow corn, grind colors, knit stockings, or assist the wheelwright and other artificers, of whom there are many employed in the establishment. For all which different sorts of labor an adequate salary is credited to each boy's class.

345. *The boys never see a newspaper, and scarcely a book; they are taught, vivâ voce, a few matters of fact, and rules of practical application: the rest of their education consists chiefly in inculcating habits of industry, frugality, veracity, docility, and mutual kindness, by means of good example, rather than precepts; and, above all, by the absence of bad example. It has been said of the Bell and Lancaster schools, that the good they do is mostly negative: they take children out of the streets, employ them in a harmless sort of mental sport two or three hours in the day, exercise their understanding gently and pleasantly, and accustom them to order and rule, without compulsion. Now, what these schools undertake to do for a few hours of each week, during one or two years of a boy's life, the School of Industry at Hofwyl, does incessantly, during the whole course of his youth; providing, at the same time, for his whole physical maintenance, at a rate which must be deemed excessively cheap for any but the very lowest of people.*

346. *The practicability of this scheme for inculcating individual prudence and practical morality, not only in the agricultural, but in all the operative classes of society, M. Simond considers as demonstrated; and it only remains to ascertain the extent of its application. "Two only of the pupils have left Hofwyl, for a place, before the end of their time; and one, with M. de Fellenberg's leave, is become chief manager of the immense estates of Comte Abaffy, in Hungary, and has, it is said, doubled its proceeds by the improved method of husbandry he has introduced. This young man, whose name is Madorly, was originally a beggar boy, and not particularly distinguished at school. Another directs a school established near Zurich, and acquits himself to the entire satisfaction of his employers. M. Fellenberg has besides a number of pupils of the higher classes, some of whom belong to the first families of Germany, Russia, and Switzerland. They live *enfamille* with their master, and are instructed by the different tutors in the theory and practice of agriculture, and in the arts and sciences on which it is founded. (See *Simond's Account of Switzerland*, vol. i. *Ed. Rev.* 1819, No. 64. *Des Institutes de Hofwyl de par Cte. L. de V.* Paris, 1821.)*

#### SUBSECT. 2. *Agriculture of the Duchy of Savoy.*

347. *Of the agriculture of Savoy, which naturally belongs to Switzerland, a general view, with some interesting details, is given by Bakewell. (Travels in the Tarantaise, &c. 1820-22.) Landed property there is divided into three qualities, and rated for a land-tax accordingly. There is an office for registering estates, to which a per centage is paid on each transfer or additional registering. There is also an office for registering all mortgages, with the particulars; both are found of great benefit to the landed interest and the public, by the certainty which they give to titles, and the safety both to borrowers and lenders on land.*

348. *Land in Savoy is divided into very small farms, and is occupied by the proprietors or paysans, who live in an exceedingly frugal manner, and cultivate the ground with the assistance of their wives and children; for in Savoy, as in many other parts of Europe, the women do nearly as much field labor as the men.*

349. *The lands belonging to the monasteries were sold during the French revolution, when Savoy was annexed to France. The gradual abolition of the monasteries had been begun by the old government of Sardinia before the revolution, for the monks were prohibited from receiving any new brethren into their establishments, in order that the estates might devolve to the crown, on the extinction of the different fraternities. This measure, though wise in the abstract, was not unattended with inconvenience, and perhaps we may add, injustice. The poor, who had been accustomed to fly to the monasteries for relief in cases of distress, were left without any support, except the casual charity of their neighbors, who had little to spare from their own absolute necessities. The situation of the poor is therefore much worse in Savoy, than before the abolition of the monasteries. The poor in England suffered in the same manner on the abolition of the monasteries in the reigns of Henry VIII. and Elizabeth, before the poor's rates were enacted. The charity of the monks of Savoy lost much of its usefulness by the indiscriminate manner in which it was generally bestowed: certain days and hours were appointed at each monastery, for the distribution of provisions, and the indolent were thereby enabled to support themselves during the whole week, by walking to the different monasteries on the days of donation. This was offering a premium to idleness, and was the means of increasing the number of mendicants, which will, in every country, be proportionate to the facility of obtaining food without labor.*

350. *The peasantry in Savoy are very poor, but they cannot be called miserable. In the neighborhood of towns, their situation is worse than at a distance; and not far from Chamberry, may be seen a few families that might almost vie in squalid misery, rags, and filth, with the poor of Ireland; but the general appearance of the peasantry is respectable. Having learnt the price of labor in various parts of Savoy, Bakewell proposed the following question: Is it possible for a laborer, with a family, to procure a sufficient quantity of wholesome food for their consumption? One of the answers was, *Cela est tres-facile*, ("It is very easy;") the other was, "The laborer lives very frugally," (*tres-sobrement*.) "In general he eats very coarse, but wholesome, bread, and, except in the mountains, he eats very little meat, and rarely drinks wine, but he has a great resource in potatoes.*

351. *One day's labor of a farming man will purchase about twelve pounds avoirdupoise of wheat, or from four to five pounds of beef, veal, or mutton; but these are dainties which he rarely tastes; potatoes, rye-bread, chestnuts, and milk, form the principal part of the food of the poor. The day-laborer in Savoy has to deduct, from the amount of his labor, about seventy days in the year, including saint-days and Sundays, on which he receives no wages." (Bakewell's Travels, vol. i. 314.)*

352. *There are four modes of occupying land for cultivation in Savoy—by the proprietors; by farmers; by grangers; and by tacheurs.*

353. *Land very near to towns is generally cultivated by the proprietors, who either keep cattle, or take them in to graze at so much per head.*

354. *By farming land*, is understood, letting it at a fixed rent, to be paid according to the value of the produce, taken at an average of ten years.

355. *By grangers*, or renting land *à moitié fruit*, is understood, that the proprietor takes half of all the grain and fruit, half the produce or increase of the cows, half the eggs, and, in short, half of every thing which is productive.

356. *By tacheurs*, is another mode of cultivating land, in the immediate vicinity of towns. The proprietors, to avoid keeping too many servants in their own houses, place a father of a family in the house upon the farm. This man is called *le tacheur*: he takes care of the cows, for half their produce: he ploughs the ground, receiving for every pair of oxen employed, or for three horses, from seventy to eighty francs per annum: he has half the wine: the share he receives of the wheat and grain is in the proportion of two parts for every nine taken by the proprietor. The latter pays all the taxes, and keeps the accounts: the tacheur may be changed every year: when he is employed in repairing fences, &c. he is paid by the day; this is always undertaken when he enters the farm.

357. *The leases granted to the farmers and grangers*, are on terms of three, six, or nine years; but when the leases are for six or nine years, a reservation is always made, that at the expiration of every three years the proprietor may revoke the lease, by giving three months' notice, if he be not satisfied with the tenant. The proprietor always supplies the farmer or granger with a sum of money without interest, called *capital* (capital), to aid him in buying oxen; for a farm of two oxen it is generally about twenty louis; for a farm of four oxen, forty louis and so on. The proprietor, for this sum, has an exclusive right to seize the cattle of the farmer, should he sell them clandestinely.

358. *The mode of pasturage* in Chamouny will apply, with little variation, to all the Alpine communes in Savoy. "The rich peasants in the Alps possess meadows, and even habitations at different heights. In winter they live in the bottom of the valley, but they quit it in spring, and ascend gradually, as the heat pushes out vegetation. In autumn they descend by the same gradation. Those who are less rich have a resource in the common pastures, to which they send a number of cows, proportionate to their resources, and their means of keeping them during the winter. The poor, who have no meadows to supply fodder for the winter, cannot avail themselves of this advantage. Eight days after the cows have been driven up into the common pasture, all the owners assemble, and the quantity of milk from each cow is weighed. The same operation is repeated one day in the middle of the summer, and at the end of the season, the quantity of cheese and butter is divided, according to the quantity of milk each cow yielded on the days of trial.

359. *There are chalets, or public dairies*, near the mountain pastures in Savoy, as well as in Switzerland; persons reside in these chalets during the summer months, to make cheese and butter. In many situations it is the labor of a day to ascend to these chalets, and return to the valleys immediately below them. There are also public dairies in some of the villages, where the poorer peasants may bring all the milk they can spare, from the daily consumption of their families. The milk is measured, and an account kept of it; and at the end of the season the due portion of cheese is allotted to each, after a small deduction for the expense of making.

360. *Of sheep*. No large flocks are kept in Savoy, as it is necessary to house them during the winter, at which time they are principally fed with dried leaves of trees, collected during the autumn. Many poor families keep a few sheep to supply them with wool for their domestic use. These little flocks are driven home every evening, and are almost always accompanied by a goat, a cow, a pig, or an ass, and followed by a young girl spinning with a distaff. As they wind down the lower slopes of the mountains, they form the most picturesque groups for the pencil of the painter, and seen at a distance, carry back the imagination to the ages of pastoral simplicity, sung by Theocritus and Virgil.

361. *The vineyards in Savoy* are cultivated for half the produce of the wine. The cultivator pays the whole expense, except the taxes, which are paid by the proprietor.

362. *Walnut-trees*, of immense size and great beauty, enrich the scenery of Savoy, and supply sufficient oil for the consumption of the inhabitants, and for the adjoining canton of Geneva. Walnuts have been called the olive of the country. The trees belong principally to the larger proprietors. They are planted by nature, being scattered over the fields, and in the woods and hedge-rows, intermixed with chestnut and forest trees of various kinds. (*Bakewell.*)

363. *The walnut-harvest* at Chateau Duing commences in September: "they are beaten off the trees with long poles; the green husks are taken off as soon as they begin to decay; the walnuts are then laid in a chamber to dry, where they remain till November, when the process of making the oil commences. The first operation is to crack the nuts, and take out the kernel: for this purpose several of the neighboring peasants, with their wives and elder children, assembled at the chateau of an evening, after their work was done. The party generally consisted of about thirty persons, who were placed around a long table in the kitchen; one man sat at each end of the table, with a small mallet to crack the nuts by hitting them on the point: as fast as they are cracked, they are distributed to the other persons around the table, who take the kernels out of the shell, and remove the inner part; but they are not peeled. The peasants of Savoy are naturally lively and loquacious; and they enliven their labor with facetious stories, jokes, and noisy mirth. About ten o'clock the table is cleared to make room for the *gouté*, or supper, consisting of dried fruit, vegetables, and wine; and the remainder of the evening is spent in singing and dancing, which is sometimes continued till midnight. In a favorable season the number of walnuts from the Duing estate is so great, that the party assemble in this manner every evening for a fortnight, before all the walnuts are cracked;

and the poor people look forward to these meetings, from year to year, as a kind of festival. They do not receive any pay; but the *gouté* and the amusements of the evening are their only reward." (*Bakewell.*)

364. *The walnut kernels* are laid on cloths to dry, and in about a fortnight are carried to the crushing-mill, where they are ground into a paste; this is put into cloths, and undergoes the operation of pressing to extract the oil. The best oil, which is used for salads and cooking, is pressed cold; but an inferior oil for lamps is extracted by heating the paste. Thirty people in one evening will crack as many walnuts as will produce sixty pounds of paste; this yields about fifteen wine quarts of oil. The walnut-shells are not lost among so frugal a people as the Savoyards, but are burned for the ashes, which are used in washing. Two pounds of these ashes are equal in strength to three of wood-ashes; but the alkali is so caustic, that it frequently injures the linen. The paste, after it is pressed, is dried in cakes, called *pain amer*; this is eaten by children and poor people, and it is sold in the shops in Savoy and Geneva.

365. *The best walnut oil*, pressed cold, has but very little of the kernelly taste; but it may be easily distinguished from the best olive oil, which it resembles in color. If the peel were taken off the walnuts, the oil would probably be quite free from any peculiar flavor; but this operation would be too tedious. (*Id.*)

366. *Tobacco*, which is much used in Savoy, was cultivated with success in the neighborhood of Ramilly; but on the restoration of the old despotism, its culture was prohibited, and the implements of manufacture seized.

367. *The culture of artificial grasses* is spreading in Savoy, but is not yet very general. In the neighborhood of Aix, Ramilly, and Annecy, wheat is succeeded by rye. The rye-harvest being over in June, they immediately sow the land with buck-wheat (*Sarrasin*), which is cut in September; the following year the land is sown with spring-corn.

368. *The grass-lands* are always mown twice, and the latter mowing is sufficiently early to allow a good pasturage in the autumn. Water-meadows are occasionally found near towns: the water is generally let down from mountain-streams; but sometimes it is raised from rivers by a sort of bucket-wheel (*fig. 47.*), which is called the *Noria*

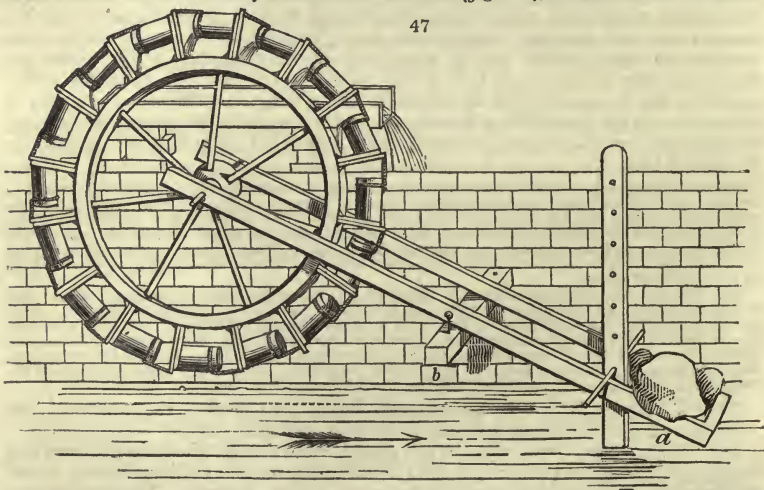

of the Alps. This wheel is raised or lowered by means of a loaded lever (*a*), which turns on a fulcrum (*b*), formed by a piece of wood, with its end inserted in the river's bank.

369. *Agricultural improvement in Savoy* must be in a very low state, if the answers Bakewell received respecting the average quantity of the produce be correct. One of the answers stated the average encrease of wheat to be from three to five on the quantity sown, and near the towns from five to seven. Another agriculturist stated the average encrease on the best lands to be nine, and in the neighborhood of Annecy thirteen fold. One part of Savoy is, perhaps, the finest corn-land in Europe; and the very heavy crops Bakewell saw in the neighborhood of Aix and Annecy, made him doubt the accuracy of the above statements. But on referring to Arthur Young's account of the agriculture of France before the revolution, it appears that four and a half was regarded as the average encrease in that country, which is very similar in climate to Savoy. (*Travels*, i. 328.)

370. *The salt-works of Moutiers*, in the valley of the Isere, in the Tarantaise, are particularly deserving attention, being perhaps the best conducted of any in Europe, with respect to economy. Nearly three million pounds of salt are extracted annually from a source of water which would scarcely be noticed, except for medical purposes, in any other country.

371. *The springs that supply the salt-works at Moutiers*, rise at the bottom of a nearly perpendicular rock of limestone situated on the south side of a deep valley or gorge. The temperature of the strongest

spring is ninety-nine Fahrenheit, it contains 1.83 per cent. of saline matter. It may seem extraordinary that the waters at Moutiers, which have only half the strength of sea-water, should repay the expense of evaporation; but the process by which it is effected is both simple and ingenious, and might be introduced with great advantage on many parts of our own coast, should the salt-duty be entirely removed. It is obvious that water, so weakly impregnated with salt as to contain only one pound and a half in every thirteen gallons, could not repay the expense of evaporating by fuel in any country. The water of the north-sea contains two and a quarter per cent. of salt, and yet it has never been attempted, to make salt from it by evaporation with coal-fires, even on the coast of Northumberland or Durham, where refuse coal, suited to the purpose, might be purchased for one shilling and sixpence per ton. In order to make salt from the saline water at Moutiers, it was necessary to concentrate it by natural evaporation; and to effect this speedily, it was required to spread the surface of the fluid over as large a space as possible, the ratio of evaporation being, *cæteris paribus*, in proportion to the extent of the surface exposed to the action of the atmosphere. The first attempt at Moutiers was made in 1550, by arranging pyramids of rye-straw in open galleries, and letting the water trickle through the straw gradually and repeatedly. This was abandoned, and faggots of thorns were substituted: these faggots are suspended on frames, the water is raised to their height, and spread by channels so as to trickle through them: it passes through three separate sets of frames of thorns, and has then become so concentrated as to contain nearly 22 per cent. of salt: it is then boiled in pans in the usual manner.

372. *Evaporating on vertical cords*, erected in a house open on all sides, is a third method, which succeeds even better than the mode by thorns. The water, by repeatedly passing over the cords, is found in forty-five days to deposit all its salt on them, and the saline cylinder is then broken off. The cords are renewed once in twenty or thirty years, and the faggots once in seven years. Minute details of these simple but very ingenious processes will be found in the very scientific *Travels of Bakewell*. (Vol. i. 230.)

### SECT. III. *Of the present State of Agriculture in France.*

373. *The first agricultural survey of France* was made in 1787, 8 and 9. by the celebrated Arthur Young. Since that period no similar account has been published either in France or England; but several French writers have given the statistics and culture of different districts, as the Baron de la Peyrouse; and others, general views of the whole kingdom, as the Abbe Rozier, and Professor Thouin. From such works, some recent tours of Englishmen, and our own observations in 1815 and 1819, we have drawn the following outline of its progress since the time of Louis XIV.; its general circumstances in respect to agriculture; its common agriculture; its culture of vines and maize; and its culture of olives and oranges.

#### SUBSECT. 1. *Progress of French Agriculture from the time of Louis XIV. to the present Time.*

374. *That France is the most favorable country in Europe for agriculture* is the opinion both of Professor Thouin and Arthur Young. Its climates are in great variety, and all excellent; and its soils are not less varied than its climates. It admits of the culture of most of the useful plants, and of the rearing of most of the profitable animals. It has a numerous population for home consumption, and rivers and sea-shores favorable for exportation.

375. *French agriculture began to flourish* in the beginning of the seventeenth century, under Henry IV., and its precepts at that time were published in the work of Olivier de Serres. In 1621, great quantities of corn were exported to England, in consequence of a wise ordinance of Sully, permitting a free commerce in corn. In 1641, the draining of fens and bogs was encouraged; and in 1756, the land-tax taken off newly broken-up lands for the space of twenty years. Colbert, during the minority of Louis XIV., prohibited the exportation of corn, and checked the progress of its culture. This circumstance, and the wars of that king, greatly discouraged agriculture, and produced several dearths. Fleury, under Louis XV., was not favorable to agriculture; but in 1754, an act was passed for a free corn trade, which effected its revival. The economists at this time, however mistaken in their views, inspired a taste for the art; and agricultural societies were first established in France under the patronage and at the expense of government. In 1761, there were thirteen of such societies in France, and nineteen co-operating societies. Those of Paris, Lyons, Amiens, and Bourdeaux, have distinguished themselves by their published memoirs. At Tours a georgical society was established, and directed by the Marquis of Tourbili, a patriot and agricultural writer. Du Hamel and Buffon gave éclat to the study of rural economy, and many other writers might be mentioned as having contributed to its improvement. M. de Trudaine introduced the Merino breed of sheep in 1776, and Comte Lasteyrie has studied that breed in Spain, and written a valuable work on the subject.

376. *Agriculture in France was not altogether neglected during the revolution.* Buonaparte established many new agricultural societies and professorships; botanic and economical gardens for the exhibition of different modes of culture, and the dissemination of plants; and he greatly enlarged and enriched that extensive institution, "the national garden," whose professor of culture, the Chevalier Thouin, is one of the most scientific agriculturists in Europe. But after all this exterior show, Chateauxvieux seems correct in stating that little was gained to the art either from these institutions, or political changes. The domains seized by the nation, he says, were sold at a low price, and a great many proprietors created, the greater number of whom do the labor of their farms for their own profit or subsistence. "It is probable, in time, these families may enjoy the state of prosperity which they expect to derive from their new situations,

but, at present, they have done nothing for the improvement of agriculture. The national property is not in sufficient estimation in public opinion to have attracted the manufacturing capital necessary to call forth its real value. This is every where perceptible in France: it is neglected, the buildings are badly kept up, the enclosures broken down, the young trees in the orchards destroyed, the dressed vines in ruins. We see, every where, the purchasers too much in haste to take possession, the natural consequence of the circumstances in which they were placed; in short, it appears uncontested, that within the last twenty years the lay purchasers have cultivated the land worse than when it was in the hands of the monks; even then, when time, which influences every thing, shall have given the purchasers a secure possession, I doubt whether the class of proprietor cultivators will effect any useful improvements in the land. Every thing requisite is wanting to accomplish it, — talent and capital. These little farmers seem placed in a country to check the progress of innovation, and to prevent all improvement in agriculture.

377. *That there has been considerable improvement in France*, he continues, “cannot, however, be doubted; but it is entirely produced by persons who have been thrown out of their situations by the revolution, and whose exertions and leisure have been directed to agriculture. They have spread a taste for it from one to another, in consequence of the success of their experiments; but still I cannot think it has been effected by throwing national domains into the capital of the nation.” (*Letters, &c.*)

378. *M. Chateauneux* is an agriculturist of great experience, and an able political economist. He has been in most parts of Europe at different times, and seems a very impartial writer: his opinion, therefore, as to French agriculture may be considered as the nearest the truth of any that has yet appeared.

SUBJECT. 2. *Of the general Circumstances of France in respect to Agriculture.*

379. *The surface of France* has been divided by geographers into what are called basins, or great plains, through which flow the principal rivers, and which basins are separated by original or secondary ridges of mountains. The chief basins are that of the Loire, (*fig. 48. a*); of the Seine, (*b*); of the Garonne, (*c*); and of the Rhone and Saone, (*d*). (*Journal de Physique*, tom. xxx.)

380. *The soil of France* has been divided by A. Young into the mountainous district of Languedoc and Provence (*e*); the loamy district of Lemosin (*f*); the chalky districts of Champagne and Poitiers (*g*); the gravelly district of Bourbonnois (*h*); the stony district of Lorraine and Franche Comte (*i*); the rich loam of Picardy and Guyenne (*k*); and the heathy surface on gravel, or gravelly sand of Bretagne and Gascoigne (*l*). (*Agr. France*, chap. ii.)

381. *The climate of France* has been most ingeniously divided by A. Young into that of corn and common British agriculture, (*fig. 48. l, b, k*); that of vines, mulberries, and common culture (*y, a, h, g, i*); that of vines, mulberries, maize, and common culture

48



(*c, f, d, i*); that of olives, vines, mulberries, maize, oranges, and common culture (*o e*). It is singular that these zones (*m m, n n*, and *o o*) do not run parallel to the degrees of latitude, but obliquely to them to such an extent that the climate for vines leaves off at 47 on the west coast (*y n*), but extends to 49½ on the east (*g m*). These zones, as may naturally be expected, extend into Germany, in which the vine is cultivated as far north as lat. 52°.

382. *The central climate*, that admits vines without being hot enough for maize, (*y, a, h, g, i*), Young considers as the finest in the world, and the most eligible part of France or of Europe as to soil. "Here," he says, "you are exempt from the extreme humidity which gives verdure to Normandy and England; and yet equally free from the burning heats which turn verdure itself into a russet brown; no ardent rays that oppress with their fervor in summer, nor pinching tedious frosts that chill with their severity in winter, but a light, pure, elastic air, admirable for every constitution except consumptive ones." This climate, however, has its drawbacks; and is so subject to violent storms of rain and hail, that "no year ever passes without whole parishes suffering to a degree of which we in Britain have no conception." It has been calculated, that in some provinces the damage from hail amounts, on an average of years, to one-tenth of the whole produce. Spring frosts are sometimes so severe as to kill the broom: few years pass that they do not blacken the first leaves of the walnut trees; the fig-trees are protected with straw.

383. *Of the vine and maize climates* (*c, f, d, i*), some account is given by M. Picot, baron de Peyrouse, an extensive and spirited cultivator. He kept an accurate account of the state of the crops and seasons in his district for twenty years from 1800; and the result is, that he has had twelve years of fair average crops; four years most abundant; and four years attended with a total loss.

384. *In the olive climate* (*o, e*) insects are incredibly numerous and troublesome, and the locust is injurious to corn crops; but both the olive and maize district have this advantage, that two crops a year, or at least three in two years, may be obtained. The orange is cultivated in so small a proportion of the olive climate as scarcely to deserve notice. The Caper (*Capparis spinosa*) (*fig. 49.*) is also an article of field culture, and the *Fig.*



385. *The climate of Picardy and Normandy is the nearest to that of England*, and is rather superior. The great advantage France possesses over Britain in regard to climate is, that by means of the vine and olive, as valuable produce may be raised on rocky wastes as on rich soils. (*Young's France*, ch. iii.)

386. *The lands of France are not generally enclosed and subdivided by hedges or other fences.* Some fences are to be seen near towns, and in the northern parts of the kingdom more especially, but in general the whole country is open; the boundaries of estates being marked by slight ditches or ridges, with occasional stones or heaps of earth, rows of trees, or occasional trees. Depredations from passengers on the highways are prevented by *gardes champêtre*, which are established throughout all France. Farms are sometimes compact and distinct, but generally scattered, and often alternating in the common field manner of England, or run-rig, of Scotland. From the operation of the present law of inheritance, estates and farms are continually breaking down into smaller divisions, so that the number of farms may be said to encrease every year. The farm-houses of large farms are generally placed on the farm; of smaller ones in villages often at some distance from the lands.

387. *The value of landed property* is in general lower than in England, being at present (1823) sold from twenty-two to twenty-six years' purchase.

388. *The farming of lands in France*, according to Professor Thouin, naturally divides itself into three kinds: 1. The grand culture, in which from two to twelve ploughs are employed, and corn chiefly cultivated. 2. The middle culture, including the metayers who also grow corn, but more frequently rear live stock, maintain a dairy, or produce silk, wine, cider, or oil, according to the climate in which they may be situated; and 3. The minor culture, or that which is done by manual labor, and into which live stock or corns do not enter. The middle culture is by far the most common. There are very few farms of six or eight ploughs in France, and equally few farmers who do not labor in person at all times of the year. It is acknowledged by Professor Thouin, that each of these divisions is susceptible of very great improvement.

#### SUBJECT 3. *Of the common Farming of France.*

389. *The corn farming in France* is carried on in the best manner in Picardy and Alsace. The first may be considered as equally well cultivated with Suffolk; and the

latter produces three crops in two years, or five in three years. Their crops are wheat, beans, turnips, maize, and buckwheat. The rotations are, generally, two corn crops and a fallow, or an alternation of corn and green or pulse crops, without a naked fallow. In the heath district, broom enters into the rotation for fuel, and is cut the fourth year; buckwheat is also extensively sown, and rye and oats. After lands have borne crops, it is usual to let them rest a year or two, during which they produce nothing but grass and weeds, and they are afterwards broken up with a naked fallow. Potatoes enter more or less into the field culture of the greater part of France, and especially of the northern districts; but in Provence and Languedoc they are still little known. Irrigation, both of arable and grass lands, is adopted wherever it is practicable. It is most common in the south, and remarkably well conducted in the lands round Avignon, formerly for many miles the property of the church.

390. *The meadows of France* contain nearly the same herbage, plants, and grasses as those of England; but though clovers and lucerne are cultivated in many places, yet rye-grass and other grasses, either for hay crops or temporary or permanent pasture, are but rarely resorted to.

391. *To sheep the French have paid considerable attention* from the time of Colbert; and there are now considerable flocks of short-wooled and Spanish breeds in some places, besides several national flocks. That of Rambouillet (established in 1786 by Louis XIV.) is managed by M. Tessier, a well known writer on agriculture, and when visited by Birkbeck, in 1814, was in excellent order. Sheep are housed, and kept in folds and little yards or enclosures, much more than in England. One-third of the sheep of France are black. Some curious attempts have lately been made to inoculate them for the claveau and the scab, but a definite result has not yet been ascertained, at least as to the latter disease. Birkbeck considers the practice of housing as the cause why the foot-rot is so common a disease among sheep in France. Where flocks remain out all night, the shepherd sleeps in a small thatched-hut or portable watchhouse, placed on wheels. He guides the flock by walking before them, and his dog guards the flock from the wolves, which still abound even in Picardy. During summer, and in the hottest districts, they are fed during the night, and housed during the heat of the day. Hay is the general winter food; and in some parts of the Picardy climate, turnips. In 1811, Buonaparte monopolized the breeding of Merinos; and from that time to the passing of an act for the exportation of wool and rams in 1814, they have declined.

392. *The beasts of labor* are chiefly the ox on small farms, and the horse on the larger. Both are kept under cover the greater part of the year. The breeds of oxen are very various; they are generally cream-coloured. The best oxen are in Normandy, which furnishes also the best breed of working horses; as Limousin does those for the saddle. In the south of France the ass and mule are of frequent use in husbandry. There, as in many parts of Italy, the poor people collect the stolones of agrostis, and creeping roots of couch, and sell them in little bundles to the carriers and others who keep road horses.

393. *A royal stud of Arabians* has been kept up at Aurillac in Limousin, for a century; and another has been lately formed near Nismes, from an extensive importation by an Englishman, purchased by government at great expense.

394. *The best dairies* are in Normandy; but in this department France does not excel. In the southern districts olive, almond, and poppy oil supply the place of butter; and goats' milk is that used in cookery.

395. *Poultry* is an important article of French husbandry, and well understood as far as breeding and feeding. Birkbeck thinks the consumption of poultry in towns may be equal to that of mutton. The smallest cottage owns a few hens, and a neat little roost (fig. 50.), in which they pass the night secure from dogs, wolves, and foxes.

396. *The breed of swine* is in general bad; but excellent hams are sent from Bretagne, from hogs reared on acorns, and fattened off with maize. Pigeon-houses are not uncommon.

397. *The management of fish-ponds* is well understood in France, owing to fish in all catholic countries being an article of necessity. In the internal district there are many large artificial ponds, as well as natural lakes, where the eel, carp, pike, and a few other species, are reared, separated, and fed, as in the Berkshire ponds in England.

398. *The implements and operations* of the common farms of France are in general rude. The ploughs of Normandy resemble the large wheel-ploughs of Kent. Those farther south are generally without wheels; often without coulters; and an iron mould-board is rare. In many parts of the south the ploughs have no mould-board, and turn the earth in the manner of the simplest form of Roman plough. (110.) Harrows are generally wholly of wood; and instead of a roller, a plank is generally used. Large farmers,





as in Normandy, plough with four or six oxen : small farmers with two, or even one ; or, when stiff soils are to be worked out of season, they join together, and form a team of four or six cattle. Their carts are narrow and long, with low wheels, seldom shod, in the remote parts of the country. The *guimbarde* of the Seine and Oise (*fig. 51.*) is a light and useful machine. Corn is reaped with sickles, hooks, the Brabant, and cradle scythe (*fig. 52.*).

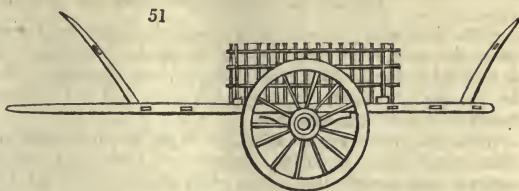

Threshing, in Normandy, is performed by the flail in houses, as in England ; in the other climates in the open air by flails, or the tread of horses. There are few permanent threshing-floors ; a piece of ground being smoothed in the most convenient part of the field is found sufficiently hard. Farmers, as we have already observed, perform most of their operations without extra laborers ; and their wives and daughters reap, thresh, plough, dig, and perform every part of the farm and garden work indifferently. Such farmers "prefer living in villages ; society and the evening dance being nearly as indispensable to them as their daily food. If the farm be distant, the farmer and his servants of all descriptions set off early in the morning in a light waggon, carrying with them their provisions for the day." (*Neill.*) Hence it is, that a traveller in France may pass through ten or twenty miles of corn-fields, without seeing a single farm-house.

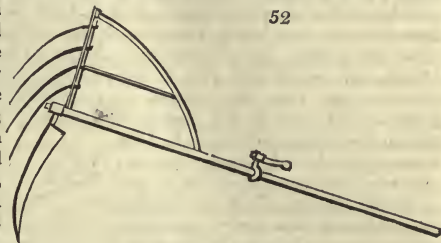

399. *Large farms* have generally farmeries on the lands ; and there the labor is in great part performed by laborers, who, as well as the tradesmen employed, are paid chiefly in kind.

400. *All the plants cultivated* in British farming are also grown in that of France ; the turnip not generally, and in the warm districts scarcely at all, as it does not bulb ; but it is questionable, as Birkbeck remarks, whether, if it did bulb, it would be so valuable in these districts as the lucerne, or clover, which grow all the winter. Of plants not usually cultivated in British farming may be mentioned, the chiccory for green food, fuller's thistle for its heads, furze and broom for green food, madder, tobacco, poppies for oil, rice in Dauphine, but now dropped as prejudicial to health, saffron about Angouleme, lathyrus sativus, the pois Breton or lentil of Spain, lathyrus setifolius, vicia lathyroides, vicia sativa, cicer arietinum, ervum lens, melilotis siberica, coronilla varia, hedsysarum coronarium, &c. They have a hardy red wheat, called *l'epautre* (spelt), said to be a distinct species found wild in Persia by Michaux and Olivier, which grows on the worst soil and climates, and is common in Alsace and Suabia. They grow the millet, the dura or douro of Egypt, (*Holcus sorghum*, L.) in the maize district. The flower-stalks and spike of this plant are sold at Marseilles and Leghorn, for making chamber-besoms and clothes brushes. The hop is cultivated ; the common fruit-trees ; and the chestnut is used as food in some places. An oil used as food, and also much esteemed by painters, is made from the walnut. The other fruits of field-culture, as the almond, fig, vine, caper, olive, and orange, belong to the culture of the southern districts.

401. *The forest culture* of France is scientifically conducted, both in the extensive national forests, and on private estates. The chief object is fuel, charcoal, bark ; and next, timber of construction ; but in some districts other products are collected, as acorns, mast, nuts, resin, &c. The French and Germans have written more on this department of rural economy than the English.

402. *A remarkable feature* in the agriculture of France, and of most warm countries, is the use of leaves of trees as food for cattle. Not only are mulberry, olive, poplar, vine, and other leaves gathered in autumn, when they begin to change color, and acquire a sweetness of taste ; but spray is cut green in July, dried in the sun or in the shade of trees in woods, faggoted, and stacked for winter use. During that season they are given to sheep and cattle like hay ; and sometimes, boiled with grains or bran, to cows. The astringency of some sorts of leaves, as the oak, is esteemed medicinal, especially for sheep. Such are the outlines of that description of agriculture which is practised more or less in all the districts of France.

SUBJECT. 4. *Farming in the warmer Climates of France.*

403. *The culture peculiar to the vine, maize, olive, and orange climates, we shall extract from the very interesting work of Baron La Peyrouse. The estate of this gentleman is situated in the maize district at Pepils, near Toulouse. Its extent is 800 acres; and he has, since the year 1788, been engaged, and not without success, in introducing a better system of agriculture.*

404. *The farm-houses and offices in the warm districts are generally built of brick; frame-work filled up with a mixture of straw and clay; or, en pisé; and they are covered with gutter-tiles. The vineyards are enclosed by hawthorn hedges, or mud-walls; and the boundaries of arable farms by wide ditches; and of grass-lands by fixed stones, or wild quince-trees. Implements are wretched, operations not well performed, and laborers, and even overseers, paid in kind, and allowed to sow flax, beans, haricots, &c. for themselves. The old plough (fig. 53.) resembles that used by the Arabs, and which the French antiquarian Gouguet (*Origine des Lois, &c.*) thinks very probably the same as that used by the ancient Egyptians. They have also a light one-handed araire (fig. 54.) A plough with coul-ters was first employed at Pepils; and a Scotch plough, with a cast-iron mould-board, was lately sent there, and excited the wonder of the whole district. In nothing is France so deficient as in agricultural imple-ments.*

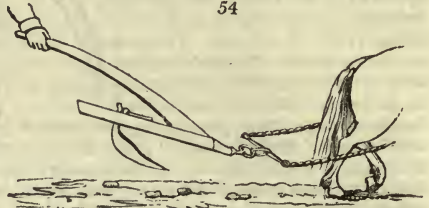
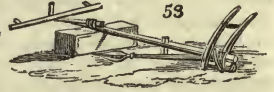

405. *Fallow, wheat, and maize is the common rotation of crops.*

406. *The live stock consists chiefly of oxen and mules; the latter are sold to the Spaniards. Some flocks of sheep are kept; but it is calculated that the rot destroys them once in three years. Beans are the grain of the poor, and are mixed with wheat for bread. The chick pea (*Cicer arietinum*,) (fig. 55.) is a favorite dish with the provincials, and much cultivated. Spelt is sown on newly broken-up lands. Potatoes were unknown till introduced at Pepils from the Pyrenees, where they had been cultivated fifty years. In the neighborhood they are beginning to be cultivated. Turnips and rutabaga were tried often at Pepils, but did not succeed once in ten years. Maize is reckoned a clearing crop, and its grain is the principal food of the people.*



407. *The vine is cultivated in France in fields, and on terraced hills, as in Italy, but managed in a different manner to what it is in that country. Here it is kept low, and treated more as a plantation of raspberries or currants are in England. It is either planted in large plats, in rows three or four feet apart, and the plants at two or three feet distance in the row; or it is planted in double or single rows alternating with ridges of arable land. In some cases also two close rows, and a space of six or seven feet alternate, to admit a sort of horse-hoeing culture in the wide interval. Most generally, plantations are made by dibbling in cuttings of two feet in length; pressing the earth firmly to their lower end, an essential part of the operation, noticed even by Xenophon. In pruning, a stem or stool of a foot or more is left above ground, and the young shoots are every year cut down within two buds of this stool. These stools get very unwieldy after sixty or a hundred years, and then it is customary, in some places, to lay down branches from them, and form new stools, leaving the old for a time, which, however, soon cease to produce any but weak shoots. The winter pruning of the vine generally takes place in February: a bill is used resembling that of Italy (fig. 37.); the women faggot the branches, and their value, as fuel, is expected to pay the expense of dressing. In summer, the ground is twice or thrice hoed, and the young shoots tied to short stakes with wheat or rye straw, or whatever else comes cheapest. The shoots are stopped, in some places, after the blossom has expanded, and the tops given to cows. In some places, also, great part of the young wood is cut off before vintage for feed to cows, and to let the sun directly to the fruit. The sorts cultivated are almost as numerous as the vineyards. Fourteen hundred sorts were collected from all parts of France, by order of the Comte Chaptal, and are now in the nursery*

of the Luxembourg; but little or no good will result from the collection, or from attempting to describe them; for it has been ascertained, that after a considerable time the fruit of the vine takes a particular character from the soil in which it was planted; so that fourteen hundred sorts, planted in one soil and garden, would in time, probably in less than half a century, be reduced to two or three sorts; and, on the contrary, two or three sorts planted in fourteen hundred different vineyards, would soon become as many distinct varieties. The *pineau* of Burgoyue, and the *auvernat* of Orleans, are esteemed varieties; and these, with several others grown for wine-making, have small berries and branches like our Burgundy grape. Small berries, and a harsh flavor, are universally preferred for wine-making, both in France and Italy. The oldest vines invariably give the best grapes, and produce the best wines. The Baron Peyrouse planted a vineyard twenty years ago, which, though in full bearing, he says, is still too vigorous to enable him to judge of the fineness and quality of the wine, which it may one day afford. "In the *Clos de Vogois vineyard*, in which the most celebrated Burgundy wine is produced, new vine plants have not been set for 300 years: the vines are renewed by laying the old trunks; but the root is never separated from the stock. This celebrated vineyard is never manured. The extent is 160 French arpents. It makes, in a good year, from 160 to 200 hogsheads, of 260 bottles each hogshead. The expense of labor and cooperage, in such a year, has arisen to 33,000 francs; and the wine sells on the spot at five francs a bottle. The vineyard is of the pineau grape. The soil, about three feet deep, is a limestone gravel on a limestone rock." (Peyrouse, 96.)

408. *The white mulberry* is very extensively cultivated in France for feeding the silkworm. It is not placed in regular plantations, but in corners, rows along roads, or round fields or farms. The trees are raised from seeds in nurseries, and sold generally at five years, when they have strong stems. They are planted, staked, and treated as pollards. Some strip the leaves from the young shoots, others cut these off twice one year and only once the next; others pollard the tree every second year.

409. *The eggs of the moth (Bombyx mori)*, (fig. 56.) are hatched in rooms heated by means of stoves to 18° of Reaumur. (72½° Fah.) One ounce of eggs requires one hundred weight of leaves, and will pro-

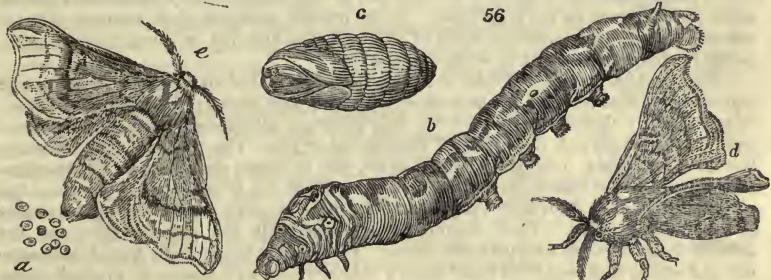

duce from seven to nine pounds of raw silk. The hatching commences about the end of April, and with the feeding is over in about a month. Second broods are procured in some places. The silk is wound off the cocoons or little balls by women and children. This operation is reserved for leisure days throughout the rest of the season, or given out to women in towns. The eggs (a) are small round objects; the caterpillar (b) attains a considerable size; the chrysalis (c) is ovate; and the male (d) and female (e) are readily distinguishable.

410. *The olive* is treated in France in the same way as in Italy. The most luxuriant plantations are between Aix and Nice. The fruit is pickled green, or when ripe, crushed for oil, as in that country.

411. *The fig* is cultivated in the olive district as a standard tree; and dried for winter use, and exportation. At Argenteuil it is cultivated in the gardening manner for eating green. (See *Encyc. of Gard.* art. Fig.)

412. *The almond* is cultivated about Lyons and in different parts in the department of the Rhone as standards in the vineyards. As it blossoms early, and the fruit is liable to injury from fogs and rains, it is a very precarious article of culture, and does not yield a good crop above once in ten years.

413. *The caper* (fig. 49.) is an article of field culture about Toulon; it has the habit of a bramble bush, and is planted in squares, ten or twelve feet plant from plant every way. Standard figs, peaches, and other fruit trees are intermixed with it.

414. The culture of the *orange* is very limited; it is conducted in large walled enclosures at Hieres and its neighborhood. The fruit, like that of Geneva and Naples, is very inferior to the St. Michel's and Maltese oranges, as imported to Britain, but the lemons are good.

415. *The winter melon* (fig. 57.) is cultivated in different parts of Provence and Languedoc, and especially in the orange orchards of Hieres. It forms an article of exportation.

416. *Various other fruits* are cultivated by the small proprietors in the southern and in all the districts of France, and sold in the adjoining markets; but this department of rural economy belongs rather to gardening than to agriculture.

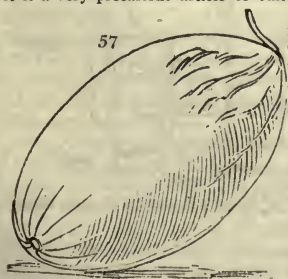

SECT. IV. *Present State of Agriculture in Holland and the Netherlands.*

417. *The agriculture of the low countries*, and especially of Flanders, has been celebrated by the rest of Europe for upwards of 600 years; that of Holland for its pasturage, and of the Netherlands for tillage. We shall notice a part of the agricultural circumstances of the two countries.

SUBJECT. 1. *Present State of Agriculture in Holland.*

418. *The climate of Holland* is cold and moist. The surface of the country towards the sea is low and marshy, and that of the interior sandy, and naturally barren. A considerable part of Holland, indeed the chief part of the seven provinces comprising the country, is lower than the sea, and is secured from inundation by immense embankments; while the internal water is delivered over these banks into the canals and drains leading to the sea, by mills, commonly impelled by wind. In the province of Guelderland and other internal parts, the waste grounds are extensive; being overrun with broom and heath; and the soil a black sand. The marshes, morasses, and heaths, which are characteristic of the different provinces, are, however, intermixed with cities, towns, villages, groves, gardens, and meadows to a degree only equalled in England. There are no hills; but only gentle elevations, and no extensive woods; but almost every where an intimate combination of land, water, and buildings. The soil in the low districts is a rich deep sandy mud; sometimes alluvial, but more frequently silicious, and mixed with rotten shells. In a few places there are beds of decayed trees; but no where rough gravel or rocks. The soil of the inland provinces is in general a brown or black sand, naturally poor, and wherever it is productive, indebted entirely to art.

419. *The landed property of Holland* is in moderate or rather small divisions, and in the richer parts, generally in farms of from twenty to one hundred and fifty or two hundred acres, often farmed by the proprietor. In the interior provinces, both estates and farms are much larger; and instances occur of farms of five hundred or seven hundred acres, partly in tillage, and partly in wood and pasture.

420. *The agriculture of Holland* is almost entirely confined to a system of pasturage and dairy management for the production of butter and cheese; the latter well known in every part of the world. Almost the only objects of tillage are some madder, tobacco, and herbage plants and roots for stall feeding the cattle. The pastures, and especially the lower meadows, produce a coarse grass, but in great abundance. The cows are allowed to graze at least a part of the day throughout the greater part of the year, but are generally fed in sheds once a day or oftener, with rape cake, grains, and a great variety of other preparations. Their manure is preserved with the greatest care, and the animals themselves are kept perfectly clean. The breed is large, small legged, generally red and white, with long, but small horns; they are very well known in England as the Dutch breed. The fuel used in Amsterdam and most of the towns is peat, and the ashes are collected and sold at high prices, chiefly to the Flemings, but also to other nations. A considerable quantity has been imported to England; they are found excellent as a top dressing for clovers and other green crops, and are strongly recommended by Sir John Sinclair and other writers. Other particulars of Dutch culture and economy correspond with the practice of the Netherlands.

421. *The field implements, buildings, and operations of Holland*, are more ingeniously contrived and better executed than those of any other country on the Continent. The best plough in the world (the Scotch plough) is derived from the Rotheram or Dutch implement. The farmeries, and especially the cow-houses and stables, are remarkable for arrangements which facilitate and economise manual labor, and ensure comfort to the animals and general cleanliness. Even the fences and gates are generally found in a better state than in most other countries. They have a simple field gate (fig. 58.) constructed with few rails, and balanced so as it may be opened and shut without straining the posts or hinges, and which deserves imitation. Their bridges, foot-planks, and other mechanical agents of culture, are in general indicative of more art and invention than is usual in continental agriculture.

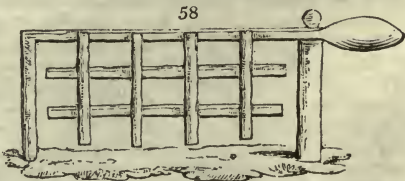

SUBJECT. 2. *Present State of Agriculture in the Netherlands.*

422. *The Netherlands and Holland*, from the tenth to the fifteenth century, were the great mart of manufactures and commerce in the west of Europe; and at the same time made distinguished progress in other arts. The particular causes which first contributed to the advancement of agriculture are not exactly known at this distance of time; but it is certain that even in the thirteenth century the art was in an advanced state, and ever since, the culture of the low countries, both agricultural and horticultural, has been looked up to by the rest of Europe.

423. *About the beginning of the seventeenth century*, according to Harte, the Flemings dealt more in the practice of husbandry, than in publishing books upon the subject: so that, questionless, their intention was to carry on a private lucrative trade without instructing their neighbors; and hence it happened, that whoever wanted to copy their agriculture, was obliged to travel into their country, and make his own remarks; as Plattes, Hartlib, and Sir R. Weston actually did.

424. *To make a farm resemble a garden as nearly as possible* was their principal idea of husbandry. Such an excellent principle, at first setting out, led them of course to undertake the culture of small estates only, which they kept free from weeds, continually turning the ground, and manuring it plentifully and judiciously. Having thus brought the soil to a just degree of cleanliness, health, and sweetness, they ventured chiefly upon the culture of the more delicate grasses, as the surest means of acquiring wealth in husbandry, upon a small scale, without the expense of keeping many draught horses or servants. After a few years experience, they soon found that ten acres of the best vegetables for feeding cattle, properly cultivated, would maintain a larger stock of grazing animals, than forty acres of common farm-grass: and the vegetables they chiefly cultivated for this purpose were lucerne, saintfoin, trefoils of most denominations, sweet fennugreek (*Trigonella*), buck and cow wheat (*Melampyrum pratense* fig. 59.), field turnips, and spurry (*Spergula*), by them called Marian-grass.

425. *The political secret of Flemish husbandry* was, the letting farms on improvement. Add to this, they discovered eight or ten new sorts of manures. They were the first among the moderns, who ploughed in living crops for the sake of fertilising the earth, and confined their sheep at night in large sheds built on purpose, whose floor was covered with sand, or earth, &c. which the shepherd carted away every morning to the compost-dunghill. Such was the chief mystery of the Flemish husbandry.

426. *The present state of agriculture in the Netherlands* corresponds entirely with the outline given by Harte, and it has probably been in this state for nearly a thousand years. The country has lately been visited with a view to its rural economy by Sir John Sinclair, and minutely examined and ably depicted by the Rev. Thomas Radcliff. To such British farmers as wish to receive a most valuable lecture on the importance of a proper frugality and economy in farming as well as judicious modes of culture, we would recommend the latter work; all that we can do here, is to select from it the leading features of Flemish farming.

427. *The climate of Flanders* may be considered as the same as that of Holland, and not materially different from that of the low parts of the opposite coast of England.

428. *The surface of the country* is every where flat, or very gently elevated, and some extensive tracts have been recovered from the sea. The soil is for the most part poor, generally sandy; but in various parts of a loamy or clayey nature. "Flanders," Radcliff observes, "was in general believed to be a soil of extreme natural richness; whereas with the exception of some few districts, it is precisely the reverse." He found the strongest and best soil near Ostend; and between Bruges and Ghent some of the worst, being little better than a pure sand.

429. *From confounding the Dutch Netherlands with the Flemish Netherlands*, a good deal of confusion in ideas has resulted. Radcliff, on arriving in Flanders, was informed that, "with respect to culture, not only the English, but the French, confounded under the general name of Brabant or Flanders, all the provinces of the low countries, however different might be their modes of cultivation; but that in Flanders itself, might best be seen, with what skill the farmer cultivates a bad soil (*un sol ingrat*), which he forces to return to him, with usury, a produce that the richest and strongest lands of the neighboring provinces of Holland refuse to yield." The districts described as East and West Flanders, are bounded on the east by Brabant and Hainault; on the west by the German ocean; on the north by the seas of Zealand, and the west Scheldt; and on the south by Picardy,



or French Flanders. It is about ninety miles long, and sixty broad, and abounds with towns and villages.

430. *The landed property of Flanders* is not in large estates: very few amount to 2000 acres. It is generally freehold, or the property of religious or civil corporations. When the proprietor does not cultivate his own lands, which, however, is most frequently the case, he lets it on leases; generally of seven, fourteen, or twenty-one years insurance, at a fixed money rent, and sometimes a corn and money rent combined. The occupier is bound to live on the premises, pay taxes, effect repairs, preserve timber, not to sublet without a written agreement; and to give the usual accommodations to an incoming tenant at the end of the lease. Leases of fourteen or twenty-one years are most common: there are scarcely any lands held from year to year, or on the metayer system. Estates are every where enclosed with hedges, and the fields generally small.

431. *Farmeries* are convenient, and generally more ample in proportion to the extent of the farm than in England. On the larger farms a distillery, oil mill, and sometimes a flour mill, are added to the usual accommodations. The buildings on a farm of 150 acres of strong soil, enumerated by Radcliff, are: 1. The farm house, with an arched cellar used as a dairy, an apartment for churning, with an adjoining one for a horse wheel to turn the churning machinery. 2. A small building for the use of extra laborers, with a fire-place for cooking. 3. The grange or great barn, 130 feet long, by 35 feet wide. The ground floor of this structure, besides accommodating by its divisions all the horses and cows of the farm in comfortable stables, and furnishing two threshing floors for the flail, is sufficient also for a considerable depôt of corn in the sheaf, in two extensive compartments to the height of twelve feet, at which elevation an open floor of joists, supported by wooden pillars, is extended over the entire area of the barn, and is repeated at every five feet in height, to the top. Each floor is braced from the pillars, and not only forms a connection of strength throughout the whole, but separates at the same time, without much loss of space, the different layers of corn, securing them from damage, by taking off the pressure of the great mass. 4. A house for farming implements, with granary over, and piggery behind. In the centre is the dunghill; the bottom of which is rendered impervious to moisture.

432. *A plan of a Flemish farmery*, is given by Sir John Sinclair, as suited to a farm of 300 acres: it is executed with great solidity and a due attention to salubrity, being vaulted and well aired. Sir John mentions, that he saw in some places, "a mode of making floors by small brick arches, from one beam to the other instead of using deals, and then making the floor of bricks," a mode now generally adopted in British manufactories; the beams which serve as abutments being of cast iron, tied together with transverse wrought iron rods.

433. *The accommodations of this farmery (fig. 60.) are,*

- |  |   |
|--|---|
| (1) The vestibule, or entrance of the farm-house.  | (24 and 25) Sheds for carts.  |
| (2) The hall.  | (26) Barn for the flax.   |
| (3, 4, and 5) Closets.   | (27) Area.  |
| (6) Sheds destined for different purposes, but more especially for elevating or letting down grain from the granaries, by machinery. | (28) Flax barn.   |
| (7) Kitchen.   | (29 and 30) Sheep-houses.   |
| (8) Washing-house.   | (31 and 32) Stables for the horses and foals.   |
| (9) Chamber for female servants.   | (33, 34, 35, and 36) Places for the hops  |
| (10) Hall.   | (37 and 38) Cisterns destined to receive the urine of the cattle.                                       |
| (11 and 12) Closets.   | (39) Well.  |
| (13) Necessaries.  | (40) Dung-pit, concave in the middle.   |
| (14) Room for the gardener.  | (41) Pool serving to receive the super-abundant waters of the dung-pit, the weedings of the garden, &c. |
| (15) Shed for fuel.  | (42) Reservoirs to receive the waters of the farm-yard.   |
| (16) Kitchen garden.   | (43) Entrance gateway, with dove-cote over.   |
| (17) Hoggery.  | (44) Small trenches, or gutters.  |
| (18) Poultry-yard.   | (45) Sheds destined for clover, cut green in summer, or dry in winter.                                  |
| (19 and 20) Stables for cows and calves.   | (46) Cistern for the wash-houses.   |
| (21) Necessaries for the servants, connected with the cisterns.  | (47) Situations of the corn stacks, in years of abundance.  |
| (22 and 23) Sheep folds.   |   |

60

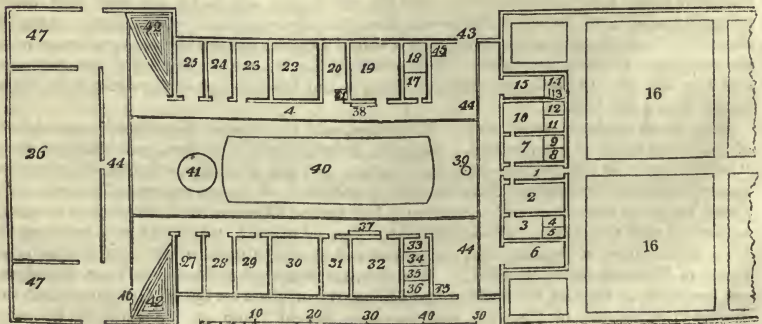

Four elevations (fig. 61. a, b, c, d,) represent the four internal sides of the quadrangle.

61

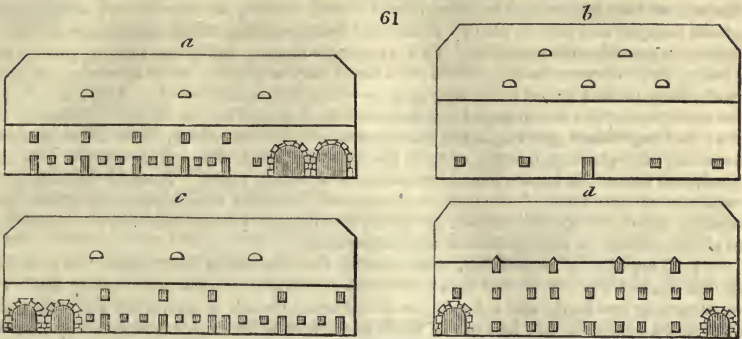

434. *Urine cisterns* are formed in the fields, to receive purchased liquid manure; but for that made in the farm-yard, generally in the yard, or under the stables. In the latter case, the urine is conducted from each stall to a common grating, through which it descends into the vault; from thence it is taken up by a pump: in the best regulated farmeries there is a partition in the cistern, with a valve to admit the contents of the first space into the second, to be preserved there free from the more recent acquisition, age adding considerably to its efficacy. This species of manure is relied on beyond any other, upon all the light soils throughout Flanders, and even upon the strong lands (originally so rich as to preclude the necessity of manure), is now coming into great esteem, being considered applicable to most crops, and to all the varieties of soil.

435. *The arable lands of Flanders* include by far the greater part of the surface of the country. The crops raised are the same as those in Britain; but from local circumstances flax, hemp, chiccory, rape, spurry, madder, woad, tobacco, and some others enter more generally into rotations.

436. *Fallows*, according to Sir John Sinclair, are in a great measure abolished, even on strong land; by means of which, produce is increased, and the expense of cultivation, on the crops raised in the course of a rotation, necessarily diminished; and by the great profit they derive from their flax and rape, or colsat, they can afford to sell all their crops of grain at a lower rate. Notwithstanding this assertion of Sir John, it will be found that a fallow enters into the rotation on all the clayey soils of Flanders.

437. *In regard to soil and culture*, Radcliff arranges Flanders into eleven agricultural divisions, and we shall notice the soil and rotations, and some other features of culture, in the first six of these divisions.

438. *The first division* extends along the north sea, and includes Ostend. This district consists of the strongest and heaviest soil which Flanders possesses, and a similarity of quality prevails generally throughout, with some occasional exceptions. It may be represented as a clay loam of a greyish colour, and yields the various produce to be expected from a strong soil; rich pasture, wheat, beans, barley, and rape, considered as primary crops; and as secondary (or such as are not so generally cultivated), oats, carrots, potatoes, flax, and tares. In this division, however, though the nature of the soil may be stated under the general description of a clay loam, yet there are of this three degrees of quality, not to be marked by regular limits, but to be found throughout the whole, in distinct situations. It becomes the more necessary to remark this, as the succession of crops depends on the quality of the soil; and as there are here three different degrees of quality, so are there three different systems of rotation.

439. *Upon the first quality of soil*, the succession is as follows: first year, barley; second, beans; third, wheat; fourth, oats; fifth, fallow. For the second quality of soil, the succession is as follows. first year, wheat; second, beans or tares; third, wheat or oats; fourth, fallow. For the third quality of soil, the succession is as follows: first year, wheat; second, fallow; third, wheat; fourth, fallow. Besides these three qualities of strong soil, another of still superior fertility prevails in this district in considerable extent, known by the denomination of Polders.

440. *The polders, or embanked lands of Flanders*, are certain areas of land reclaimed from the sea by embankment, whose surface, once secured from the influx of the tide, becomes the most productive soil, without requiring the assistance of any description of manure. They owe their origin partly to the collection of sand in the small branches of rivers, gradually increasing, so as naturally to embank a portion of land, and convert it into an arable and fertile soil. They also have proceeded from the contraction of the river itself, which, by the effect of the tides, is diminished in one place, whilst an alluvial soil is formed in another by its overflow. Hence it is, that within a century, entire polders in certain situations have been inundated, whilst, in others, new and fertile land has appeared, as if from the bosom of the water. These operations of nature pointed out facilities many centuries back, which excited the industry of the low countries, and has been rewarded by the acquisition of their richest soil. These newly formed lands, before

their embankment, are called *schorres*. They are flooded at every tide by the water of the sea, and are augmented by mire, bits of wood, rushes, sea-weeds, and other marine plants decayed and putrid, also by shells and fishy particles which the ebb always leaves behind in considerable quantity. This growing soil soon produces various plants and grasses, and improves daily. When such lands have acquired a crust or surface of black earth, three or four inches deep, they may be embanked and fallowed. Those are always the most productive which have been deepened in their soil by the augmentations of the sea; and experience proves, that in the corners and hollows where, from an obstructing boundary, the greatest quantity of mire has been deposited, the soil is doubly rich and good, and cannot be impoverished by the crops of many years. In some instances, the embankments are made on the part of government, in others, by companies or individuals, under a grant of a specific tenure, (generally twenty-one years), rent free, or according to circumstances, at some moderate annual payment.

441. *The polder of Snaerskirke*, near Ostend, contains about 1300 acres. It is of late formation, and was overflowed by a creek with its minor branches every spring tide. By constructing two banks and a flood-gate at the creek the sea is excluded, and the space subdivided by roads, and laid out in fields of thirteen acres each, surrounded by ditches. The bank is fifteen feet in height, thirty feet in the base, and ten feet across the top: the land which has been reclaimed by it, was let for a sheep pasturage at 600 francs (25*l.*) per annum, and was thrown up by the farmer as untenable. Upon being dried by this summary improvement, the lots of which are one hundred, of thirteen acres each, and were sold by auction at an average of 7000 francs (291*l.* 13*s.* 4*d.*) each, would now bring nearly double that rate. They are let to the occupying farmers at 36 guilders the *mésure*, or about 2*l.* 15*s.* the English acre, and are now producing superior crops of rape, of sucron, (winter barley), and beans, which constitute the usual rotation; this, however, is varied according to circumstances, as follows:—1. oats, or rape; 2. winter barley, or rape; 3. winter barley; 4. beans, pease, or tares.

442. *Other examples of reclaimed lands are given.* One called the *Great Moor*, recovered through the spirited exertions of M. Hyrwein, contains 2400 acres. Attempts had been made to recover it by the Spaniards, in 1610, but without success. This marsh was seven feet below the level of the surrounding land; therefore, to drain it, the following operations became necessary:

443. *To surround the whole with a bank* of eight feet in height, above the level of the enclosed ground, formed by the excavation of a *fossée*, fifteen feet wide and ten feet deep, which serves to conduct the water to the navigable canal.—*To construct mills* to throw the water over the bank into the *fossée*.—*To intersect the interior* by numerous drains from eight to twelve feet wide, with a fall to the respective mills, to which they conduct all the rain water, and all the seepage water which oozes through the banks.

444. *The mills in use* for raising the water, are of a simple but effectual construction, and are driven by wind. The horizontal shaft above works an upright shaft at the bottom, of which a screw bucket, twenty-four feet in length, is put in motion by a bevil wheel, at such an angle as to give a perpendicular height of eight feet from the level of the interior drain to the disgoring of the water, which is emptied with great force into the exterior canal. With full wind, each mill can discharge 150 *tonneaux* of water every minute. The height of the building from the foundation is about fifty feet, one half of it above the level of the bank. The whole is executed in brick-work, and the entire cost 36,000 francs, about 1500*l.* British. It is judiciously contrived that the drains, which conduct the water to the mills, constitute the divisions and subdivisions of the land, forming it into regular oblong fields of considerable extent, marked out by the lines of ozier which ornament their banks. Roads of thirty feet wide lead through the whole in parallel directions.

445. *The soil of this tract*, which has been formed by the alluvial deposit of ages, is a clay loam, strong and rich, but not of the extraordinary fertility of some polders, which are cropped independent of manure for many years. The first course of crops commencing with rape, is obtained without manure, and the return for six years is abundant; the second commences and proceeds as follows:

1st Year, fallow, with manure from farm-yard.  
2d Ditto, sucron (winter barley)  
3d Ditto, beans.  
4th Ditto, wheat.

5th Year, clover.  
6th Ditto, beans and pease mixed.  
7th Ditto, oats.

446. *The second division* adjoins Picardy, but does not extend to the sea. The soil may be described as a good loam of a yellowish colour, mixed with some sand; but is not in its nature as strong as that in the former division. Its chief produce is wheat, barley, oats, hops, tobacco, meadow, rape-seed and flax, as primary crops; and as secondary, buck-wheat, beans, turnips, potatoes, carrots, clover. This division, unlike the former in this respect, is richly wooded.

447. *The general course of crops in this division is as follows:*

1. Wheat upon manured fallow.  
2. Clover, top dressed with ashes.  
3. Oats, } same year, without manure,  
4. Turnips, }  
5. Flax, highly manured with urine and rape cake.  
6. Wheat.

7. Beans.  
Or in lieu of the last three crops, thus:  
5. Fallow manured.  
6. Rye.  
7. Wheat.  
8. Beans, manured.



- 9. Wheat.
- 10. Oats.
- 11. Turnips.
- 12. Rye.
- 13. Tobacco, three times ploughed, and richly manured.

- 14. Wheat.
  - 15. Hops, with abundant manure.
- This last crop remains generally five years, and the ground is afterwards fit for any kind of produce.

448. *In another part of this division*, where hops are not grown, the following rotation is observed :

- 1. Potatoes, with manure.
- 2. Wheat.
- 3. Beans, with manure.
- 4. Rye.
- 5. Wheat, with manure.
- 6. Clover, top-dressed with ashes.
- 7. Turnips, with manure.
- 8. Flax, highly manured with urine and rape cake.

- 9. Wheat.
- 10. Oats, } same year.
- 11. Turnips, }
- 12. Fallow, without manure.
- 13. Rye.
- 14. Tobacco, richly manured.
- 15. Wheat.

449. *In addition to those crops* in some part of the district, particularly in the line between Woomen and Ypres, magnificent crops of rape are cultivated, and are relied on as a sure and profitable return. Flax is also a crop upon which their best industry is bestowed, and their careful preparation of the soil is scarcely to be surpassed by that of the neatest garden.

450. *In the fourth division* the soil is a good sandy loam, of a light color, and is in a superior state of cultivation ; it yields a similar produce to the foregoing division, with the same quality of hay ; but plantations are here more numerous. The succession is as follows :

- 1. Wheat, with dung.
- 2. Clover, with ashes, seed sometimes saved.
- 3. Flax, with urine and rape cake.
- 4. Wheat, with compost of short dung and various sweepings.
- 5. Potatoes, with farm-yard dung or night soil.
- 6. Rye, with urine.
- 7. Rape seed, with rape cake and urine.
- 8. Potatoes, with dung.
- 9. Wheat, with manure of divers kinds.

- 10. Clover, with ashes, seed sometimes saved.
  - 11. Oats, without manure.
  - 12. Flax, with urine and rape cake.
  - 13. Wheat, with dung.
  - 14. Beans, with dung.
  - 15. Best root, with rape cake, or Tobacco, with rape cake in great quantities.
- Turnips are also grown, but are taken as a second crop after rape, flax, wheat, or rye.

451. *Passing over the other divisions to the eighth and ninth*, we find the reporter describes them as of considerable extent, and in the poverty of their soil and abundance of their produce, bearing ample testimony to the skill and perseverance of the Flemish farmers. The soil consists of a poor light sand, in the fifteenth century exhibiting barren gravel and heaths. The chief produce here is, rye, flax, potatoes, oats, buck-wheat, rape-seed, and wheat in a few favorable spots ; clover, carrots, and turnips generally.

452. *On the western side of these districts*, and where the soil is capable of yielding wheat, there are two modes of rotation : one comprising a nine years' course, in which wheat is but once introduced ; and the other a ten years' course, in which they contrive to produce that crop a second time ; but in neither instance without manure, which, indeed, is never omitted in these divisions, except for buck-wheat, and occasionally for rye. The first course alluded to above, is as follows :

- 1st Year, potatoes or carrots, with four ploughings, and twelve tons of farm-yard dung, per English acre.
- 2d Year, flax, with two ploughings, and 105 Winchester bushels of ashes, and 48 hogheads, beer measure, of urine, per English acre.
- 3d Year, wheat, with two ploughings, and ten tons and a half of farm-yard dung, per English acre.
- 4th Year, rye and turnips, with two ploughings, and ten tons and a half of farm-yard dung, per English acre.

- 5th Year, oats with clover, with two ploughings, and ten tons and a half of farm-yard dung, per English acre.
- 6th Year, clover, top-dressed, with 105 Winchester bushels of peat or Dutch ashes, per English acre.
- 7th Year, rye, with one ploughing, and 52 hogheads, beer measure, of night soil and urine.
- 8th Year, oats, with two ploughings, and 52 hogheads, beer measure, of night soil and urine.
- 9th Year, buck wheat, with four ploughings, and without any manure.

453. *Of the Flemish mode of cultivating some particular crops*, we shall give a few examples. The drill husbandry has never been generally introduced in the low countries. It has been tried in the neighbourhood of Ostend, forty acres of beans against forty acres of drilled crop, and the result was considered to be in favor of the system. But the row culture, as distinguished from the raised drill manner, has been long known in the case of tobacco, cabbages, and some other crops.

454. *Wheat* is not often diseased in Flanders. Most farmers change their seed, and others in several places steep it in salt water or urine, and coppers or verdigrise. The proportion of verdigrise is half a pound to every six bushels of seed ; and the time in which the latter remains in the mixture is three hours, or one hour if cows' urine be used, because of its ammonia, which is considered injurious. The ripest and plumpest seed is always preferred for seed.

455. *Rye* is grown both as a bread corn, and for the distillery. In Flanders frequently, and in Brabant very generally, the farmer, upon the scale of from one hundred to two hundred acres of light soil, is also a distiller, purely for the improvement of the land by the manure of the beasts, which he can feed upon the straw of the rye, and the grains of the distillery.

456. *Buck-wheat* enters into the rotations on the poorest soils, and is sown on lands not got ready in time for other grain. The chief application of buck-wheat is to the feeding of swine and poultry, for which it is pre-eminent ; it is also used in flour ; as a constituent in the liquid nourishment prepared for cattle and horses ; and bears no inconsiderable share in the diet of the peasant. Formed into a cake without yeast, it is a very wholesome, and not a disagreeable species of bread ; but it is necessary to use it while

fresh, as, if kept, it would turn sour sooner than bread made of barley, rye, or wheat flour. Its blossom is considered to afford the best food for bees. If cut green, it yields good forage, and if ploughed in when in flower, it is thought one of the best vegetable manures in use. It is also said to be used in distillation; but this is not generally admitted to be the case.

457. *Rape, colzá, colsat, or cole seed*, (not the *brassica napus* of Linnaeus, but the *B. campestris* of Decandolle, and which he thinks a distinct species,) is considered an important article of Flemish agriculture. It is sometimes sown broad-cast, but the general and approved method is, by transplanting, which they allege, and apparently with great justice, to have many advantages: one is, that the seed-bed occupies but a small space, whilst the land which is to carry the general crop is bearing corn. By having the plants growing, they have time to harvest their corn, to plough and manure the stubble intended for the rape, which they put in with the dibble, or the plough, from the latter end of September to the second week of November, without apprehending any miscarriage.

458. *The seed-bed* is sown in August, and even to the middle of September. In October, or sooner, the stubble is ploughed over, manured, and ploughed again. The plants are dibbled in the seams of the ploughing, (each furrow slice being twelve inches broad,) and are set out at twelve inches distance in the rows. Instead of dibbling upon the second ploughing, in many cases they lay the plants at the proper distances across the furrow, and as the plough goes forward, the roots are covered, and a woman follows to set them a little up, and to give them a firmness in the ground where necessary. Immediately after the frost, and again in the month of April, the intervals are weeded and hand-hoed, and the earth drawn up to the plants, which is the last operation till the harvest. It is pulled rather green, but ripens in the stack; it is threshed without any particular management; but the application of the haulm, or straw, is a matter of new and profitable discovery: it is burned for ashes, as manure, which are found to be so highly valuable beyond all other sorts which have been tried, that they bear a price as three to one above the other kinds, and it is considered, that upon clover, a dressing of one-third less of these is amply sufficient.

459. *The seed is sold for crushing*; or, as is frequently the case, crushed by the farmer himself; an oil mill being a very common appendage to a farmery.

460. *The oilette or poppy (Papaver somniferum)*, is cultivated in some parts, and yields a very fine oil; in many instances, of so good a quality, as to be used for salad oil. The seed requires a rich, and well manured soil. The crop is generally taken after rape, for which the ground has been plentifully manured; and for the oilettes it receives a dressing not less abundant. The seed is sown at the rate of one gallon to the English acre, and is lightly covered by shovelling the furrows. The average produce is about thirty Winchester bushels to the English acre. The seed is not so productive as rape, in point of quantity, but exceeds it in price, both as grain and as oil, by at least one-sixth. The measure of oil produced from rape, is as one to four of the seed; that produced from the seed of the oilettes, is as one to five.

461. *Poppy seed* is sown both in spring and autumn, but the latter is considered the best season; great attention is given to the pulverisation of the soil, by frequently harrowing, and (if the weather and state of the soil permit,) sufficient rolling to reduce all the clods.

462. *The harvesting of the poppy* is performed in a particular manner, and requires a great number of hands. The laborers work in a row, and sheets are laid along the line of the standing crop, upon which, bending the plants gently forward, they shake out the seed. When it ceases to fall from the capsules, that row of the plants is pulled up, and placed upright in small sheaves, in the same, or an adjoining field, in order to ripen such as refused to yield their seed at the first operation. The sheaves are then again drawn forward to the standing crop, and the same process is repeated, till all the plants be shaken, pulled up, and removed. In two or three days, if the weather has been fine, the sheets are placed before the rows of the sheaves, which are shaken upon them, as the plants were before; if any seed remain, it is extracted in the barn by the flail; and if the weather be unpromising, the plants are not left in the field after the first operation, but are placed at once under some cover to ripen, and yield the remainder of their seed, either by being threshed or shaken.

463. *The red clover* is an important and frequent article in the Flemish rotations. The quantity of seed sown does not exceed six pounds one quarter to the English acre. The soil is ploughed deep and well prepared, and the crop kept very clear of weeds. Their great attention to prevent weeds, is marked by the perseverance practised to get rid of one, which occasionally infests the clover crop, and is indeed most difficult to be exterminated. The *orobanche* or broom rape (*Orobanche major*) (fig. 62.) is a parasitical plant, attaching itself to the pea tribe, which, in land where clover has been too frequently sown, stations itself at its root, and if suffered to arrive at its wonted vigor, will spread and destroy an entire crop. The farmer considers the mischief half done, if this dangerous plant be permitted to appear above the surface; and he takes the precaution to inspect his clover in the early spring. The moment the *orobanche* establishes itself at the root, the stem and leaf of the clover, deprived of their circulating juices, faden to a sickly hue, which the farmer recognises, and, with true Flemish industry, roots up, and destroys the latent enemy. If this be done in time, and with great care, the crop is saved; if not, the infected soil refuses to yield clover again for many years.

62



464. *The turnip* is not generally cultivated as a main crop, but generally after rye, or rape, or some crop early removed. The turnip is sown broad-cast, thinned, and hoed with great care; but it affords a very scanty crop of green food, generally eat off with sheep in September or later. The Swedish turnip is unknown, and indeed the turnip husbandry, as practised in Britain, cannot be considered as known in Flanders.

465. *The potatoe* was introduced early in the seventeenth century, but attracted little notice till the beginning of the eighteenth. It is cultivated with great care. The ground is trenched to the depth of nearly two feet; and small square holes having been formed at about eighteen inches from each other, the set is deposited therein, the hole nearly filled with dung, and the earth thrown back over all. As the stalks rise they are earthed up from the intervals, and manured with liquid manure; and as they continue to rise, they receive a second earthing round each distinct plant, which, with a suitable weeding, terminates the labor. Notwithstanding the distance between the plants, the whole surface is closely covered by the luxuriance of the stems, and the return is abundant. If the seed be large, it is cut; if small, it is planted whole: in some parts of the Pays de Waes they drop the potatoe sets in the furrow as the plough works, and cross-hoe them as they rise; but the method first mentioned is the most usual, and the produce in many cases amounts to ten tons and one-sixth, by the English acre.

466. *Potatoes are the chief food of the lower classes.* They are prized in Flanders, as being both wholesome and economical, and are considered there so essential to the subsistence of a dense population, that at one time it was in serious contemplation to erect a statue, or some other monument of the country's gratitude, to the person who first introduced amongst them so valuable a production. They are also very much used in feeding cattle and swine; but for this purpose, a particular sort, much resembling our ox-noble, or cattle-potatoe, is made use of, and the produce is in Flanders, as with us, considerably greater than that of the other kinds intended for the table.

467. *The carrot* is a much valued crop in sandy loam. The culture is as follows: after harvest they give the land a moderate ploughing, which buries the stubble, and clearing up the furrows to drain off the waters, they let the field lie so for the winter; early in spring they give it a second ploughing very deep, (from eleven to twelve inches,) and shortly after they harrow the surface well, and spread on it ninety-six carts of manure to the bonnier, about twenty-one tons to the English acre. This manure is in general half from the dunghill, and half of what is termed *merde*, or a collection from the privies, which being ploughed in, and the surface made smooth, they sow the seed in the month of April, broad-cast, and cover it with a harrow. The quantity sown is estimated at eleven pounds to the bonnier, or about three pounds to the English acre. The average produce, about one hundred and sixty bushels to the English acre.

468. *The carrot, as nutritive food both for cattle and horses,* is a crop extremely valuable. In Flanders it is generally substituted in the room of hay, and a moderate quantity of oats is also given. To each horse, in twenty-four hours, a measure is allotted, which weighs about twenty-five pounds. This appears a great quantity, but it makes hay-feeding altogether unnecessary. To each of the milch cows, a similar measure is given, including the tops, and this is relied on for good butter, both as to quantity and quality.

469. *The white beet or mangold-würzel* is not in use in Flanders as food for cattle, but was once cultivated very extensively for the production of sugar. At the time the French government encouraged the manufacture of sugar from this root, experiments were made on a considerable scale, and with great success, in the town of Bruges. The machinery was unexpensive, and the remaining cost was merely that of the manual labor, and a moderate consumption of fuel. The material itself came at a very low rate, about ten shillings British by the ton; and to this circumstance may be chiefly attributed the cessation of the manufacture. Instead of encouraging the cultivator, the government leaned altogether to the manufacturer, and made it imperative on every farmer to give up a certain proportion of his land to this root, without securing to him a fair remuneration. The consequence was, that the manufacturers, thus supported, and taking advantage of the constrained supply, have in many instances been known to refuse payment even of the carriage of a parcel, in other respects sent in gratuitously; and a consequence still more natural was, that the farmers, wherever they had the opportunity of shaking off so profitless a crop, converted the space it occupied to better purposes.

470. *To the manufacturer of beet root sugar* the profit was ample: an equal quantity of sugar with that of the West Indies, which at that time sold for five shillings a pound, could be produced on the spot from mangold-würzel, at less than one shilling by the pound: and to such perfection had the sugar thus made arrived, that the prefect, mayor, and some of the chief persons of Bruges, who were invited by a manufacturer to witness the result of his experiments, allowed the specimens which he produced to exceed those of the foreign sugar.

471. *The process of manufacturing beet root sugar,* as then in use, was simple: a cylindrical grater of sheet-iron was made to work in a trough, prepared at one side in the hopper form, to receive the clean-washed roots of the beet, which, by the rotation of this rough cylinder, was reduced to a pulp. This pulp, when placed in bags of linen or hair-cloth, and submitted to a pressure resembling that of a cider-press, yielded its liquor in considerable quantity; which, being boiled and subjected to a proportion of lime, the saccharine matter was precipitated; the liquor being then got rid of, and a solution of sulphuric acid

being added, and boiled again, the lime was disengaged; the saccharine matter being then freed from the liquor, granulated, and was ready for the refiner. The pulp has been found to yield, upon distillation, a wholesome spirit, very inferior, but not very unlike to geneva. It has been proved excellent as a manure, but not valuable as food for cattle, beyond the first or second day from the press. The foregoing process required but a fortnight to complete it.

472. *Flax* is cultivated with the utmost care. The field intended for this crop, after two or three ploughings and harrowings, is again ploughed, commencing in the centre, and ploughed round and round to the circumference, so as to leave it without any furrow. The heavy roller is drawn across the ploughing by three horses; the liquid manure is then spread equally over the entire surface, and when well harrowed in by eight or nine strokes of the harrow, the seed is sown, which is also harrowed in by a light harrow, with wooden pins of less than three inches; and the surface, to conclude the operation, is again carefully rolled. Nothing can exceed the smoothness and cultivated appearance of fields thus accurately prepared.

473. *The manure universally used for the flax crop*, demands particular notice: it is termed liquid manure, and consists of the urine of cattle, in which rape-cake has been dissolved, and in which the *vidanges* conveyed from the privies of the adjoining towns and villages, have also been blended. This manure is gradually collected in subterranean vaults of brick-work, at the verge of the farm next to the main road. Those receptacles are generally forty feet long, by fourteen wide, and seven or eight feet deep, and in some cases are contrived with the crown of the arch so much below the surface of the ground, as to admit the plough to work over it. An aperture is left in the side, through which the manure is received from the cart by means of a shoot or trough, and at one end an opening is left to bring it up again, by means of a temporary pump, which delivers it either into carts or tonneaus.

474. *The liquid is carried to the field* in sheets or barrels, according to the distance. Where the cart plies, the manure is carried in a great sheet called a *voile*, closed at the corners by running strings, and secured to the four uprights of the carts: two men, standing one on each side of the cart, scatter it with hollow shovels upon the rolled ground; or where the tonneaus are made use of, each is carried by two men with poles, and set down at equal intervals across the field in the line of the rolling. There are two sets of vessels, which enable the men, who deposit the loaded ones, to bring back the others empty. One man to each vessel, with a scoop, or rather a kind of bowl with a long handle, spreads the manure, so as to cover a certain space; and thus, by preserving the intervals correctly, they can precisely gauge the quantity for a given extent of surface. For the flax crop they are profuse; and of this liquid mixture, in this part of the country, they usually allow at the rate of 2480 gallons, beer measure, to the English acre.

475. *Spurry* (*Spergula arvensis*) (fig. 63.) is cultivated on the poorest soils. It is so quick of growth and short of duration, that it is often made to take an intermediate place between the harvest and the spring sowing, without any strict adherence to the regularity of succession. It is sown sometimes in the spring, but in general in the autumn, immediately after harvesting the corn crops. One light ploughing is sufficient; and as the grain is very small, it is but very lightly covered. About twenty-four pounds of seed to the acre is the usual quantity. Its growth is so rapid that in five or six weeks it acquires its full height, which seldom exceeds twelve or fourteen inches. The crop is of course a light one, but is considered of great value, both as supplying a certain quantum of provender at very little cost, and as being the best food for milch cows, to improve the quality of the butter. It lasts till the frost sets in, and is usually fed off by milch cows tethered on it, but is sometimes cut and carried to the stalls.



476. *Where spurry is sown in spring* the crop is occasionally made into hay; but from the watery nature of the plant, it shrinks very much in bulk, and upon the whole, is much more advantageously consumed in the other manner. It is indigenous in Flanders; and, except when cultivated, is looked on as a weed, as in this country.

477. *The hop* is cultivated on good soils, and generally after wheat. The land being four times ploughed, the plants are put in in the month of May, in rows with intervals of six feet, and at six feet distance in the row. In the month of October they raise the earth round each plant, in little mounds about two feet and a half high, for the purpose of encouraging a number of shoots, and of preserving them from the frost. When all harsh weather has disappeared, about the beginning of April in the second year, they level those little heaps, and take away all superfluous shoots at the root, leaving but four or five of the strongest. They then spread over the entire surface, at the rate of twelve carts of 1500lbs. each, by the English acre, of dung, either of cows, or of cows

and swine mixed; but they avoid the heat and fermentation of horse-dung. This dressing is given when the shoots begin to appear; at which time also, they fix in the earth close to each hill, a pole of dry wood, about eighteen feet in length, for the vines to cling by. In the month of July, they give the surface another dressing with urine, at the rate of 1000 gallons the English acre. In the month of August, the crop has nearly arrived at its full growth, and flourishes in all its beauty.

478. *The crop is ready to gather in the month of September*, when they cut the runners at about three feet from the ground, and in November they cut them to the earth; they then heap up the soil about each plant as before, to the height of two feet and a half, and follow precisely the same course as above-mentioned, each year, during five, which is the usual time they suffer the plantation to continue, and at the expiration of which the land is in the highest condition, and suited to the reception of any other crop.

479. *Madder* is sometimes cultivated, but only on land of the best quality, and with plenty of manure. At the end of April or May; according as the young plants are large enough to be transplanted, the land must be ploughed in beds of two feet and two feet and a half wide; the beds are then to be harrowed and raked, and the young suckers of the roots or plants are to be put down in rows, at intervals of a foot or a foot and a half, and at six or eight inches distance in the row.

480. *During the entire summer* the land should be frequently stirred, and kept free from weeds. In the month of November, when the leaves are faded, the plants are covered with two inches of earth by a plough, having the point of the coulter a little raised or rounded, so as not to injure the young plants.

481. *In the following spring*, when the young shoots are four or five inches long, they are gathered or torn off, and planted in new beds, in the same manner as has been pointed out above; and then in the month of September or October, after the faded leaves have been removed, the old roots are taken up.

482. *The madder thus taken up* should be deposited under cover, to protect it from the rain; and after ten or twelve days, placed in an oven moderately heated. When dried sufficiently, it is gently beaten with a flail, to get rid of any clay that may adhere to the plants; and by means of a small windmill, is ground and sifted, to separate it from any remaining earth or dirt. It is then replaced in the oven for a short time, and when taken out is spread upon a hair-cloth to cool; after which it is ground and cleaned once more. It is then carried to a bruising-mill, and reduced to a fine powder, and is packed in casks or barrels for market.

483. *The culture of woad*, though not general, has been practised in Flanders. It was an object with the French government to spread the cultivation of it, and a considerable quantity of seed was sent gratis into the country for that purpose.

484. *Woad thrives only on gravelly and sandy soils*, which must be well pulverized, manured, and formed into beds, as in the case of madder culture. It is sown in March or April in rows, or broad-cast and harrowed or covered with a rake. All weeds are cleared away, and the plants thinned, if a careful culture is followed. The leaves are the part of the plant which is used by the indigo manufacturer. They should be gathered singly like those of spinach, as soon as they begin to shew signs of maturity, and the mature leaves taken off from time to time as they grow. This operation goes on from June to September in the first year, and from June to August in the second; when the plant being a biennial, shoots into flower stems. The leaves are fermented, and the dye precipitated from the liquor and dried, &c. in a manner analogous to what is practised in India with indigo; but with great improvements made at the instigation of the French government, which, in 1810, called forth the process described in a French work, and translated in the appendix to Radcliff's report. At present it is to be considered more as matter of curious historical information, or of local adoption than of general utility; because no mode of cultivating or preparing woad could bring it into competition, either in the European or American market, with indigo.

485. *With culinary vegetables the Flemish markets are abundantly supplied*. Most of these are grown by the small farmers, and are of excellent quality. To every cottage in Flanders a garden of some description is attached; and according to the means, the leisure, and the skill of the possessor, is rendered more or less productive. The general principles of management with all are, frequent digging, careful weeding, ample manuring, and immediate succession. The rotation depends on circumstances. The chief vegetables in common use are, parsnip, carrot, turnip, scorzonera, savoy, jettechou cabbage (Brussels sprouts), onions, leeks, pease, beans, and all kinds of salading, with another vegetable called *five haricot*, a large species of French bean, which has a place in the field or garden of almost every farmer, and being sliced down, pod and seed, is made a chief ingredient in all farm-house cookery.

486. *The treatment of asparagus* here, and generally in Flanders, differs considerably from our method: in forming their beds, they are not by any means particular as to very deep trenching, or a profusion of manure; nor, as they grow up, do they cover the beds with litter for the winter, nor fork and dress them in the spring: in the furrows they form a rich and mellow compost of earth and dung, with which, before winter sets in, they dress up the beds to the height of nearly eighteen inches from the level of the crowns, and without any further operation (except supplying the furrows again for the ensuing year), as soon as the buds appear, they cut them nine inches under the surface, by which means, having but just reached the light, the whole of the stock is blanched and tender.

487. *The frequent manurings given by the Flemish farmer astonish a stranger; the difficulty is the sources whence it is obtained in sufficient quantity, and this can only be resolved by referring to the practice of soiling;—to the numerous towns and villages; and to the care with which every particle of vegetable or animal refuse is saved for this purpose. Manure in Flanders as in China is an article of trade. The selling price of each description is easily ascertained: the towns let the cleaning of the streets and public retiring places at great rents. Chaptal says there are in every town sworn brokers, expressly for the purpose of valuing night soil; that these brokers know the exact degree of fermentation in that manure which suits every kind of vegetable, and at the different periods of their growth. (Chimie appliquée à l'agriculture, &c. l. 137.)*

488. *Every substance that constitutes, or is convertible to manure, is sought after with avidity, which accounts for the extreme cleanliness of the Flemish towns and pavements, hourly resorted to, with brooms and barrows, as a source of profit. Even the chips which accumulate in the formation of wooden shoes worn by the peasantry, are made to constitute a part of the compost dung-heap; and trees are frequently cultivated in barren lands, merely to remain till their deciduous leaves shall, in course of time, have formed an artificial surface for the purpose of cultivation. The manures in general use are,*

489. *The farm-yard dung, which is a mixture of every matter that the farm-yard produces, formed into a compost, which consists of dung and litter from the stables, chaff, sweepings, straw, sludge, and rubbish, all collected in a hollow part of the yard, so prepared as to prevent the juices from being wasted; and the value of this, by the cart-load of 1500 lbs. of Ghent, is estimated at five francs.*

490. *The dung of sheep, pigeons, or poultry.* By the same cart-load, five francs and a half.

491. *Sweepings of streets and roads.* Same quantity, three francs.

492. *Ashes of peat and wood mixed.* Same quantity, eight francs.

493. *Privy manure and urine.* Same quantity, seven francs.

494. *Lime.* Same quantity, twenty-four francs.

495. *Rape cake.* Per hundred cakes, fifteen francs.

496. *Gypsum, sea-mud, and the sediment of the canals,* have been all tried experimentally, and with fair results; but the two former have been merely tried; the latter is used successfully in the vicinity of Bruges.

497. *Bone manure* was altogether unknown in Flanders; but, at the suggestion of Radcliff, is now under experiment in that country.

498. *The agricultural implements of Flanders are by no means such as the excellence of the Flemish culture would lead us to suspect. They are in general of rude workmanship, but constructed with attention to strength, durability, and cheapness.*

499. *The plough has a rude appearance, but works easily and makes excellent work in loose friable soil; though it would not make a sharp angled furrow-slice in breaking up pastures. It is never drawn by more than two horses, and on light sands often by one, or by a single ass.*

500. *The binot or waloon plough used in Brabant, described by Sir John Sinclair, is a plough with a double or scuffler share, two mould-boards, but no coulter. It is chiefly used for breaking up lands. If the soil is foul, they employ it two or three times, for the purpose of cleaning it thoroughly. The land is not turned over, as by the plough, and the weeds buried, but the soil is elevated into small ridges, by means of which the couch and other root-weeds are not only cut, but they are exposed to the frost in winter, and to the drought of spring, and when the land becomes dry, which it does quickly when thus elevated, these weeds are collected by the harrow, by a trident (or large pitch-fork), by a rake, or by the hand. After the binot, the land is always ploughed for the seed furrow. This implement and its application are strongly recommended to the British farmer, by Sir J. Sinclair, as improvements; but as the editor of the *Farmer's Magazine* observes, the implement is nothing more than a double mould-board plough, and the operation of ridging with it is the justly exploded practice of "ribbing." The late machinist Weir informed us, that he had orders for several binots from Sir J. S. and others, and that he used exactly the same form, as when a double mould-board plough was ordered.*

501. *The mouldebaert (fig. 64.), is a curious and useful implement. It resembles a*

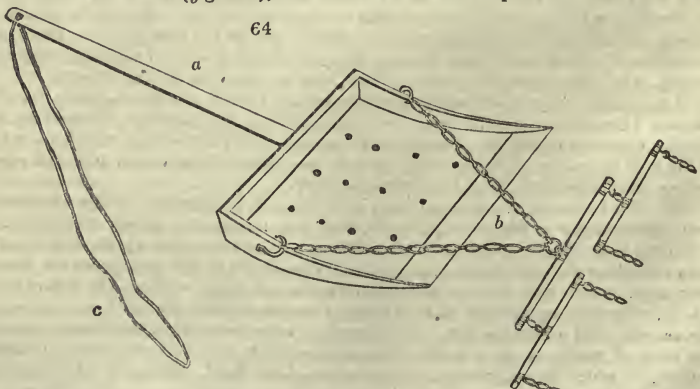

large square malt or cinder shovel, strongly prepared with iron on the cutting edge, and

is drawn by a pair of horses with swingle trees. It is used to lessen inequalities of surface, by removing a part of the soil from the heights to the hollows, which it does in an easy and expeditious manner. The person who drives with long reins, by pressing moderately on the handle (a) as the horses go forward, collects, and transports about five hundred weight of earth to the place where it is to be deposited; which is effected in the most summary manner by his letting go the handle: this causes the front, or edge of the machine, (b) to dip, and catch against the ground, whereby it is at once inverted and emptied of its load. The extremity of the handle, to which a rope (c) is affixed, by this inversion strikes against, and rests upon the swingle-tree bar, and in this manner the mouldebaert is drawn along towards the accumulated earth, when, by taking up the rope, the driver draws back the handle, collects his load as before, proceeds to the spot which is to receive it, and the horses are never for a moment delayed. The saving of time and labor, in filling and emptying, gives this implement a decided superiority over the cart; nor is the ground so much injured by this, as by wheels.

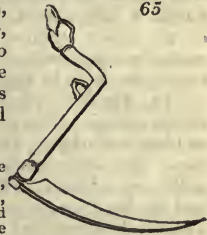

502. *The Hainault scythe* (fig. 65.) is the general reaping instrument. The handle is fourteen inches, with a shield for the hand of four and half inches, in all eighteen and a half inches: the blade is two feet three inches in length, the point a little raised, and the entire edge bevelled upwards so as to avoid the surface of the ground, and the frequent use of the sharpening stone. The handle of the crook being of hard wood, is used as a scythe board.

503. *The great Brabant scythe* (fig. 66.), differs little from the British implement, and is in general use for mowing clover.

504. *The kylanderie*, to which Radcliff seems to attach unmerited importance, is nothing more than a screen for freeing grain from vermin, dust, or small seeds. It resembles a gravel screen and is used in the same manner.

505. *The trenching spade* consists of a blade of iron fifteen inches long, and a handle of two feet. The laborer standing in the last formed trench, with his left hand at the bottom of the handle, and his right near the top, by the weight of his body, and without the assistance of his foot, sinks the spade about eighteen inches, and standing sideways, throws off the soil with a peculiar sleight and turn of the wrist, so as to lodge it in an oblique position in the trench, and against the preceding line of work, retiring as he casts it from the spade, and thereby effecting some little mixture of the two strata, though the upper surface is at the same time placed below the other.



506. *The pronged hoe* has a pronged blade on one side, and a common plate on the other; it is exceedingly useful; one side may be used for cutting weeds where they prevail, and the other for stirring a surface already clean.

507. *The chariot, or great cart*, (fig. 67.) is the only machine of the Flemish farmer which appears to transgress the bounds of a rigid economy. This, as it is not only to be used for the transport of grain, but of the farmer and his family occasionally, to the market-town, is more ornamentally finished than any other, and is painted in showy colours, chiefly green and red; an awning also is very ingeniously contrived as an occasional defence against the rain and sun. From the natural spring of so long a perch, the centre part of this machine

67

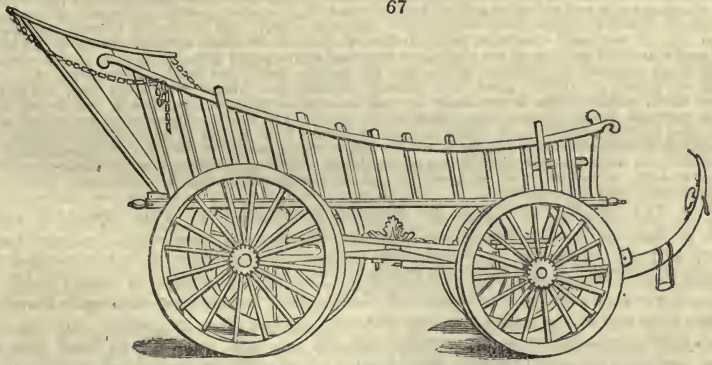

is by no means an uneasy conveyance; and there the farmer sits in all solemnity, whilst a well-appointed boor acts as a postillion, and his fine and spirited pair of well-trained horses bring him home from market at a rapid trot.

508. *Agricultural operations* of every kind are performed with particular care in Flanders. The most remarkable feature in the operations of culture is the frequent ploughings given on all soils; in strong soils, for the sake of pulverization as well as cleanliness; in the latter, chiefly for the destruction of weeds, and blending the manure with the soil. But considering that but one pair of horses is in general allowed to about thirty acres, it is surprising how (with the execution of all the other farming work) time can be found for the number of ploughings which are universally given. Very generally, the number, for the various crops respectively, is as follows:

For <i>Wheat</i> ,	Two	ploughings,	with two harrowings.	For <i>Oilseeds</i> ,	Two or three	ploughings,	with two harrowings,
<i>Rye</i> ,	Two or three	ditto,	ditto.	<i>Tobacco</i> ,	Four	ditto,	ditto.
<i>Oats</i> ,	Three	ditto,	ditto.	<i>Hemp</i> ,	Four	ditto,	ditto.
<i>Potatoes</i> ,	Four	ditto,	ditto.	<i>Turnip</i> ,	{ Three as a first crop,	ditto,	ditto.
<i>Carrots</i> ,	Four	ditto,	ditto.		{ One as a second crop,	ditto,	ditto.
<i>Flax</i> ,	Two	ditto,	ditto.		{ Three as a first crop,	ditto,	ditto.
<i>Buckwheat</i> ,	Four	ditto,	ditto.	<i>Spurry</i> ,	{ One as a second crop,	ditto,	ditto.
<i>Rape</i> ,	Three	ditto,	ditto.	<i>Beans</i> ,	Two,	ditto,	ditto.
<i>Barley</i> ,	Three	ditto,	ditto.	<i>Fallows</i> ,	Four or five	ditto,	ditto.

509. *Trenching* is a feature almost peculiar to Flemish farming, and that of Tuscany. This remarkable practice is confined to the lighter soils, and is unused where the strong clay prevails. In the districts in which it is adopted, the depth of the operation varies with that of the soil; but till this shall have arrived at nearly two feet of mellow surface, a little is added to it at each trenching, by bringing to the top a certain proportion of the under stratum, which, being exposed to the action of the atmosphere, and minutely mixed with a soil already fertilised, gradually augments the staple till the sought-for depth be required.

510. *The live stock of Flanders*, though good, is not so eminently exemplary as their tillage culture. The cattle are the short-horned Dutch breed; the color generally black, or black and white. Little attention is given to the improvement of the form by selection. The sheep are long wooled, long legged, and afford a coarse fleece, and very indifferent mutton. They are housed at night, and in the day-time follow the shepherd and his dog through pathways and along the verges of the fields and roads, picking up a mere subsistence, and never enjoying the range of a sweet and wholesome pasture. In winter they are let out but once a day, and are fed on rye in the sheep houses, and hay, &c. A cross with the Merino breed has been tried; but, as might have been predicted from the incongruous parentage, with no benefit. The swine are long legged, narrow backed, and flat ribbed; not easily fatted, but when well fed and long kept, making excellent pork and bacon.

511. *The horse* is the animal for which Flanders has long been noted for the excellence of its working breed; and that of England has been considerably improved by the frequent importation from thence, of stallions and mares, previous to the French revolution. The Suffolk punch horse comes nearest to the most prevalent variety in Flanders; the resemblance is strong not only in color, but in some of the essential points of form; and however, though the prevailing color is chestnut in all its shades, yet other colors are likewise to be met with; and, with very few exceptions, the Flemish horses are of superior strength, and of the true working character. The chief, indeed almost the only defects to be observed in any are, a want of depth in the girth, and a dip behind the withers; for symmetry, perhaps the shoulder also, at the top, should be a little finer; but in all other respects they possess the best shapes.

512. *Every farmer breeds his own work-horses*, and disposes of the redundancy. Even the total absence of pasture is not suffered to prevent it; and the foals are found to thrive remarkably well in a close house. For this purpose, as well as for the general keep of the stock, a regular dietary is observed. The manger is formed of well-cemented brick-work, and in summer, clover, and in winter, carrots, are usually given; hay in very small quantities, but in all cases chopped straw mixed with corn or beans, or both, and water aired by keeping in the stable, and whitened with a pretty strong proportion of barley-meal. With every symptom of sufficient spirit, they are docility itself; and besides being obedient to the word, are guided in intricate cases, in a manner surprising to a stranger, by a single cord; this rein is never thick, and, in some instances, is as small as a stout whipcord, and yet in the deeper soils three powerful horses abreast (the bridles of the middle and off-side horses being connected with that upon the near-side horse, to which this rein is affixed,) are guided by it at all the turnings, the ploughman holding the rein in one hand, and his single-handed plough in the other, and performing his work with the most accurate straightness and precision. Of corn to market, a pair of horses generally draw two tons; of manure to the field, one ton and half; and on the pavement in the towns, three tons, without appearing to be overloaded.

513. *The shoeing of horses in Flanders* is attended to with particular care, and in that country has long been practised the mode of preserving the bars of the hoof, and of letting the frog come in contact with the ground, recommended in England by Freeman and Professor Colman. The use of cockers, or turned heels, is, excepting in part, entirely abandoned. In two respects, however, the shoeing in Flanders differs from any of the methods in use with us. In *one*, that to prevent ripping, the hoofs of the fore-feet are pared away towards the toe, and the shoes so fitted, that the fore part shall not touch (within three-fourths of an inch) the same level surface, upon which the heel and middle of the shoe shall rest.

514. *This preparation of the foot* is in general use; the horses are not thereby in any degree injured, and are particularly surefooted. The other point of difference is, that the shoe is nailed on flat and close to the foot, which, in depriving the iron of all spring, and all unequal pressure against the nails, may be in part the cause of the durability of the shoeing.

515. *For shoeing vicious horses* every precaution is taken by the use of the forge machine, a common appendage to the smiths in Flanders. If the horse is not altogether unmanageable his hind foot is tied to a cross bar, or his fore leg to a still and bracket; but if he is extremely vicious indeed, he can be raised from the ground in a minute, by means of a cradle-sling of strong girth web, hooked to the upper side-rails, which, with a slight hand-spike, are turned in the blocks that support them (the extremities of the sling thereby coiling round them), till the horse is elevated to the proper height, and rendered wholly powerless.

516. *The Flemish and Dutch dairies* are more remarkable for the abundance than the excellence of their products; owing to the inferiority of their pastures, and the cows



being kept the greater part of the winter in the house. In summer the principal article of food in Flanders is clover, cut and carried to the stall. On a small scale when pasturage is to be had, they are left at liberty; when this is not the case, each cow is led by a rope, and permitted to feed round the grassy borders of the corn-fields, which are left about ten feet wide for this purpose.

517. *The food for one cow in winter* for twenty-four hours, is straw, eighteen pounds; turnips, sixty pounds. Some farmers boil the turnips for them; others give them raw, chopping them with the spade: one or other operation is necessary to obviate the risk of the animal being choked, where the turnips, which is usually the case in Flanders, are of too small a size. In lieu of turnips, potatoes, carrots, and grains, are occasionally given; bean-straw likewise, and uniformly a white drink, prepared both for cows and horses, and consisting of water in which some oilcake has been dissolved, and whitened with rye-meal, oatmeal, or the flour of buckwheat.

518. *In the Dutch dairies* the summer feed is pasturage day and night; in winter, hay, turnips, carrots, grains from the breweries, cakes of linseed, rapeseed, bean and other meals, and the white drink before mentioned. For the sake of cleanliness, the tails of the cows are tied to the roof of the cow-house with a cord during the time of milking. The cow-houses both in Flanders and Holland are kept remarkably clean and warm; so much so that a gentleman "spoke" to Radcliff "of having drank coffee with a cowkeeper in the general stable in winter, without the annoyance of cold, of dirt, or any offensive smell." The Dutch are particularly averse to unfolding the secrets of their dairy management, and notwithstanding the pointed queries of Sir John Sinclair on the subject, no satisfactory idea was given him of their mode of manufacturing butter or cheese.

519. *The woodlands of Flanders* are of considerable extent; but more remarkable for the care bestowed on them than for the bulk of timber grown. For the latter purpose, indeed, the soil is too poor; most of these woods having been planted or sown on land considered too poor for tillage.

520. *In forming artificial plantations*, the general mode is to plough the ground three or four times, and take a crop of huckwheat; afterwards the plants or seeds are inserted and hoed for a year or two, till they cover the surface. For the Scotch pine, which is sometimes sown alone on the poorest soils, the most common and simplest mode, is that of burning the surface, to which process its heathy quality gives great facility. The ashes being spread, the ground is formed into beds from six to fifteen feet wide, according to circumstances; the seed sown at the rate of six pounds to the English acre, and covered by a light shovelling from the furrows, which are sunk about two feet, not only to supply covering to the beds, but as drains to carry off the surface water.

521. *Extensive artificial woods* have been created in this manner, converting a barren soil into a state of production, the least expensive, very profitable, and highly ornamental. Of six years' growth, there exist flourishing plantations (treated in this manner), from five to nine feet in height. At about ten years from its formation, they begin to thin the wood, and continue to do so annually, with such profit by the sale, as at the end of thirty years to have it clear of every charge; a specific property being thus acquired, by industry and attention merely, without the loss of any capital.

522. *Pine woods are often sown*, and with great success, without the labor of burning the surface, as at Vladslø, in the neighborhood of Dixmude, where a luxuriant crop of but five years' growth, and seven feet in height, had been cultivated by Madame de Cleir, by merely ploughing the heathy surface into beds of fifteen feet, harrowing, sowing at the rate of six pounds to the English acre, raking in the seed, and covering the beds lightly from the furrows, which are sunk about eighteen inches deep.

523. *Another mode of sowing*, practised by the Baron de Serret, in the vicinity of Bruges, was productive of a growth not less luxuriant, merely by sowing the seed upon sand (taken from the excavation for a building) which was spread over the heathy surface, the seed raked in, and the furrows shovelled up.

524. *The sowing of pine seed* in many cases is adopted for the purpose of bringing waste land into an arable state, which, when the timber has been disposed of, is found to yield admirable crops, from a surface soil formed by the accumulation of the leaves which have fallen for so many years. For this purpose also, the broom is frequently sown upon waste lands of a similar description, and at the end of four or five years is pulled away, leaving the soil capable of yielding crops of corn.

525. *The preservation of trees* is attended to in the strictest manner, not only by proprietors, but the government. As an example of this, Radcliff mentions, that at a certain season of the year, when the caterpillars commence their attack upon the trees, every farmer is obliged to destroy those upon his own premises, to the satisfaction of the mayor of his particular commune, or to pay the cost of having it done for him. As a proof of the strictness with which this is enforced, the governor sends round a circular letter annually, reminding the sous intendants and mayors of the obligations and penalties for non-performance.

526. *There are a number of royal forests* in Flanders; and besides these, all the trees on the sides of the public roads belong to the government. In West Flanders there are five, amounting together to nearly 10,000 acres. They are superintended by eighteen persons, an inspector, resident at Bruges; a deputy inspector, resident at Ypres; two *gardes généraux*, and fourteen *particuliers*, or privates. The inspector is answerable for all: from him the *garde general* takes his instructions, and sees that they are enforced by the privates, to whom is committed the regulation of the necessary labor.

527. *The cuttings take place periodically* with respect to small trees and fire-wood, so as to secure an annual produce; but reserves are always left to become, eventually, large and valuable timber.

528. *The cutting of the taillis or coppice*, chiefly used as fire-wood, takes place every eleventh year; that of the high and grosser coppice, every twenty-fifth year; the felling of the half-grown forest trees every sixtieth year; and that of the full-grown forest trees, once in a hundred years.

529. *In the management of coppices*, it is considered essential to preserve the roots from stagnant water; the trenches originally formed for that purpose are from time to time cleared out; and the sediment and manure from the falling leaves, which have accumulated in them, is carefully spread upon the ridge, or rounded set, which the wood occupies. A second branch of regular attention is to remove all brambles and briars. A third, to replace the old and fading stocks by new plantations. A fourth, to thin the stems with regularity and care.

530. *The sorts of trees* are birch, oak, service, ash, maple, elm, beech, poplar, aspen, wild pine, Weymouth pine, plane, lime, larch, Spanish chestnut, alder. A variety of pine, called the *Pinus maritimum*, has been tried on the sea-coast, and found to resist the sea breeze. It is said extensive plantations have been made of this tree on the coast of France, at Bourdeaux, and that it produces excellent timber; but whether it is a distinct species, or a variety possessing any particular qualities, or merely the common wild or Scotch pine, in a favorable situation, does not appear. Most probably the latter circumstance is the case. The pine is liable to the attacks of the *Dermestes pini-perda*, L. (fig. 68.) on the wood of the old branches, and the larva of a species of moth, on the leading young shoots. The moth deposits its eggs among the buds at their extremities: the turpentine or resin which oozes from the buds, protects the eggs till the insect is brought out by the warmth of the atmosphere, when vegetation commences; it then inserts itself into one of the buds, which at this time begins to shoot, and lodging itself in the centre of it, perforates the young shoot up and down, till it either breaks off, or withers.



531. *The domestic circumstances* of the Flemish farmer and his servants are depicted by Radcliff in a favorable point of view. "Nothing," he says, "tends more to the uniform advancement of good farming, than a certain degree of ease and comfort in those who occupy the soil, and in the laboring classes whom they employ. Without it, an irregular, speculative, and anticipating extraction of produce, always followed by eventual loss, is resorted to, in order to meet the emergencies and difficulties of the moment; whereas, under different circumstances, the successive returns of a well-regulated course, become the farmer's object, rather than the forced profit of a single year; whilst he himself is thus intrinsically served, his landlord secured, and his ground ameliorated.

532. *The laborious industry of the Flemish farmer* is recruited by intervals of decent and comfortable refreshment; and the farm-servants are treated with kindness and respect. They uniformly dine with the farmer and his family, at a clean table-cloth, well supplied with spoons, with four-pronged forks, and every thing necessary for their convenience. In Flanders, the gentlemen are all farmers, but the farmers do not aspire to be gentlemen; and their servants feel the benefit. They partake with them of a plentiful and orderly meal, which varies according to circumstances. One standing dish, however, is universal, a soup, composed of buttermilk, boiled and thickened with flour, or rye-bread, potatoes, salt pork, salt fish, various vegetables, and eggs: fresh meat and fresh fish occur occasionally, though not for daily consumption; add to these, a plentiful supply of butter, or rendered lard, which is sometimes substituted; and when it is recollected that those articles of provision are always made palatable by very tolerable cookery, it will be allowed that the farmer's table is comfortably supplied. The potatoes are always peeled, and are generally stewed in milk; a particular kind of kidneybean, as mentioned before, the *feve haricot*, sliced and stewed in milk also, is a frequent dish. No farmer is without a well-cultivated garden, full of the best vegetables, which all appear at his own table; and apples are also introduced into their cookery. The great fruit and vegetable markets of the towns are supplied by gardeners, who make that their subsistence; but the gardens of the farmers, unless in case of redundancy, are cultivated wholly for their own consumption."

533. *The farm-servants* partake of their master's fare, except in his refreshments of tea, coffee, and beer.

534. *The day-laborers* are not so well provided: they have, however, rye-bread, potatoes, buttermilk, and occasionally some salt pork. The laborer is, in general, very well able to support himself by his work: in a country where so much manual labor is required in weeding, the laborer's family is occupied pretty constantly in summer; and in winter they spin. Each day-laborer has, in most cases, a small quantity of land, from a rood to half an acre, for his own cultivation.

535. *Beggars* in common times are scarcely to be seen, except in the towns, and but few there. In the country, habits of industry are kept up till health fails; and to meet the infirmities of age, the poor possess a revenue from pious donations, regulated by the government, and vested by them in commissions, of which the mayors of the different communes are presidents, respectively, in right of their office.

536. *The clothing of the peasantry* is warm and comfortable, good shoes, stockings, and frequently gaiters of leather or strong linen, which are sold very cheap; their innate frugality leads them, however, to economise in those articles, substituting on many occasions coarse flannel socks and wooden *sabots*, both of which are supplied in all the public markets, at about eightpence cost. Their comfortable supply of linen is remarkable; there are few of the laboring classes without many changes. In riding with a landed proprietor through a part of the country in which his property was situated, a neat cottage presented itself: the clipped hedge which surrounded the garden, covered with lincn very white, suggested an enquiry, "whether it did not belong to a washer-woman?" The answer was, "That it was occupied by a laborer and his family, and that the lincn was all their own." It must, however, be observed, that universally in proportion to the supply, is the postponement of the washing, which causes the greater display, and particularly at the beginning of May, which is a chosen season for this purpose. Any circumstance connected with the cleanliness, health, and comfort of the lower classes, is interesting; and to

this of which we have been speaking, a peculiar degree of decency is attached. If the laborer is comfortable in point of apparel, the farmer is still more so. In home-work, the farmer generally protects his clothes by a smock-frock of blue linen: a great attention to cleanliness prevails throughout.

537. *With respect to the farm-house*, the exterior is for the most part ornamented by creepers, or fruit-trees trained against the walls; and within, the neatness which prevails is quite fascinating. Every article of furniture is polished; the service of pewter displays a peculiar brightness; and the tiled floor is purified by frequent ablutions.

538. *The cottage of the laborer*, though not so well furnished, is, however, as clean; a frequent and periodical use of water, and the broom, pervades every house, great and small, in the country and in towns; originating, perhaps, in the necessity of cleanliness, and the public enforcement of it, when Flanders was visited by the plague.

539. *The Flemish farmer seldom amasses riches*, but is rarely afflicted by poverty; industry and frugality are his characteristics; he never looks beyond the enjoyment of moderate comforts; abstains from spirituous liquors, however easily to be procured; never exceeds his means; pays his rent punctually; and, in case of emergency, has always somewhat to command, beyond his necessary disbursements.

540. *From this outline of Flemish rural economy*, confessedly the best in the climate to which it belongs with the exception of Britain, what are the general conclusions to be drawn by a British farmer? Sir John Sinclair, who visited the country with the avowed purpose of "ascertaining whether it was not in our power to put an end to that extraordinary difference between the prices of grain in Britain and Flanders (p. 1. and 83.) which exists at present (1815), or at any rate to bring it nearer its former standard, thus concludes: "that this may be accomplished, there is every reason to hope will be the case, provided proper attention is paid to the various particulars enumerated in the preceding pages, and more especially to the following: To a change of seed from the Continent;—the importation of Dutch ashes for our clover, and other crops;—the use of salt for agricultural purposes;—a diminution of fallows;—more attention to weeding and to manures;—a more general culture of flax and rape;—and, above all, to the means by which the diseases of wheat, and the mildew in particular, can be most effectually prevented." (*Tract on Flemish Agriculture*, p. 85.)

541. *Our opinion on this subject* is different: to us, the means to which, according to Sir John Sinclair, proper attention must be paid, appear most inadequate for the end proposed, and more especially "the use of salt, Dutch ashes, diminution of fallows, and a more general culture of flax and rape." The doctrine of the diminution of fallows, so much insisted on, we consider to be one of the most ruinous ever held forth to practical farmers. Happily, the most intelligent of these know better than to adopt it in practice. Economy, industry, and cleanliness, are the words which indicate the gleanings to be made by the British farmer in Flanders:—but as to lowering the price of grain by adopting any of these Flemish practices, the idea is ridiculous.

542. *The improvements which might be adopted from Great Britain, by Flemish farmers*, enumerated by Sir John Sinclair, entirely coincide with our views, and we shall therefore barely enumerate them. They are the adoption of the drill-machine, and plough combined for beans and pease; the threshing machine; iron pillars for corn stacks; rye-grass to sow with the red clover; an improved breed of sheep; the same of hogs and cows; lime; salt (to a certain extent, and principally for seasoning the food of cattle); the Swedish turnip, the improved sorts of potatoe, drilled turnips, and temporary pastures.

#### SECT. V. *Present State of Agriculture in Germany.*

543. *The agriculture of Germany* is, in many respects, less different from that of Britain than is the agriculture of France or Italy. It is, however, but very imperfectly known in this country; partly from the numerous petty states into which the German empire is divided, which greatly increases the variety of political circumstances affecting agriculture; but principally from the German language being less generally cultivated by Britons, than that of France or of Italy. The outline which we submit, is drawn chiefly from the published journals of recent travellers, especially Jacob, Hodgson, and Bright, and from our own observations made in 1813 and 1814. We might have rendered it much more copious by availing ourselves of some knowledge of the German language, and consulting original works; but the very contracted statements which we must have given, in order not to exceed our limits, would not have compensated either the writer or the reader. We have, therefore, only noticed the general circumstances of the country as to agriculture; its common or corn and cattle culture; and the culture of the warmer climates.

#### SUBSECT. I. *General View of the Agricultural Circumstances of Germany.*

544. *A great variety of soil, surface, climate, and culture*, must necessarily exist in a country so extensive as Germany. From the south of Hungary to the north of Denmark, are included upwards of twelve degrees of latitude, which alone is calculated to pro-

duce a difference of temperature of twenty degrees: and the effect of this difference of geographical position is greatly increased by the variations of surface; the immense ridges of mountains; inlets of the sea, lakes, and rivers, and extensive plains. The winters in Denmark and Prussia are very severe, and last from six to eight months; the winters in the south of Hungary are from one to three months. The south and south-east of Germany, comprising part of Bohemia, Silesia, and Hungary, are the most mountainous; and the north-east, including Prussia and part of Holstein and Hanover, presents the most level surface. The richest soil is included in the interior and south-western parts; in the immense plain of the Danube, from Presburg to Belgrade, an extent of three hundred miles; and great part of Swabia, Franconia, and Westphalia. The most barren parts are the mountains and sandy plains and heaths of the north, and especially of Prussia; and that country, and part of Denmark and Holstein, abounds also in swamps, marshes, and stagnant lakes.

545. *Landed property* throughout Germany is almost universally held on feudal tenure, and strictly entailed on the eldest son. It is generally in estates from one hundred acres upwards, which cannot be divided or encreased. Most of the sovereigns have large domains, and also the religious and civil corporations.

546. *The farmers of Germany* are almost every where metayers; but the variety of this mode of holding is much greater there than in France and Italy. In many cases the farmer does not even find stock; and in others, as in Hungary and part of Prussia, he and his family are little better off than the slave cultivators of Russia. In Brandenburg, Saxony, and part of Hanover, the farmers hold on the meyer tenure, or that of paying a fixed rent of corn or money, unalterable either by landlord or tenant. In Mecklenburg, Friesland, and Holstein, most of the property is free, as in Britain, and there agriculture is carried to great perfection. Tithes are almost universal in Germany; but are not felt as any great grievance. Poor-rates are unknown.

547. *The consequence of these arrangements* of landed property in Germany is a comparatively fixed state of society. The regulations which have forbid an augmentation of rent, or a union of farms, and which have secured to the owner the full enjoyment of the use of the land, have prevented any person, except the sovereign, from amassing an enormous quantity, and have preserved among the inhabitants a species of equality as to property. There are, comparatively, few absolutely destitute laborers. The mass of the people do not live in such affluence as Englishmen; but this is more than compensated to them by all being in some measure alike. In civilised society, it is not destitution, but the craving wants which the splendor of other persons excites, which are the true evils of poverty. The meyer regulations have hindered improvement; but they have also hindered absolute destitution and enormous accumulation.

548. *From the regulations concerning landed property in Germany*, it has resulted that fewer paupers are found there than in our country. Some other regulations are known, which have probably assisted in protecting Germany from the evil of pauperism to the same extent in which it exists with us. There is no legal provision for paupers. A law of the guilds, which extended to most trades, forbid, and still forbids, where guilds are not abolished, journeying mechanics from marrying; and, in most countries of Germany, people are obliged to have the permission of the civil magistrate before it is legal for the clergyman to celebrate a marriage. The permission seems to be given or withheld as the parties soliciting it are thought by the magistrates to be capable of maintaining a family. At least, it is to prevent the land from being overrun with paupers that the law on this subject has been made.

549. *The agricultural produce of Germany* is for the greater part consumed there; but excellent wines are exported from Hungary and the Rhine; and also wool, flax, timber, bark, hams, salted and smoked, geese, goose quills, the canary, goldfinch, and other singing birds, silk, &c.

550. *The culture of the mulberry and rearing of the silkworm in Germany*, is carried on as far north as Berlin; that of the vine, to Dresden; and that of the peach, as a standard in the fields, to Vienna. The maize is little cultivated in Germany; but patches of it are to be found as far north as Augsburg, in Swabia. Rice is cultivated in a few places in Westphalia. The olive is not planted, because to it, even in the warmest part of Germany, the winters would prove fatal.

551. *The common cultivation* includes all the different corns; and many or most of the legumes, roots, herbage, and grasses, grown in Britain. They grow excellent hemp, flax, and oats; and rye is the bread-corn of all Germany. They also cultivate turnips, rapeseed, madder, woad, tobacco, hops, saffron, teasle, carroway; many garden vegetables, such as white beet, French beans, cabbage, carrot, parsnip, &c.; and some medicinal plants, as rhubarb, lavender, mint, &c., independently of their garden culture of fruits, culinary vegetables, and herbs for apothecaries. The most common rotation in Germany is two corn crops and a fallow; or, in poor lands, one or two corn crops, and two

or three years' rest; but in rich lands, in the south-western districts, green crops or legumes intervene with those of corn.

552. *The best pastures and meadows* are in Holstein, and along the margin of the German Ocean; and for the same reasons as in Holland and Britain; viz. the mildness and moisture of the winters. There are also good pastures and meadows on the Danube, in Hungary; but the great heats of summer stimulate the plants too much to send up flowers; and the culture there is not so perfected as to regulate this tendency by irrigation. Irrigation, however, is very scientifically conducted in some parts of Holstein, and on the Rhine and Oder.

553. *The operations and implements* of German agriculture vary exceedingly. They are wretched in Hungary, and some parts of Bohemia, where six or more oxen may be seen drawing a clumsy plough, entirely of wood, and without a mould-board. In Denmark, Hanover, and in Prussia, they use much better ploughs, some of which have iron mould-boards; and in many places they are drawn by a pair of oxen or horses. The plough, in the more improved districts, has a straight beam, two low wheels, a share, which cuts nearly horizontal, and a wooden mould-board, sometimes partially shod with iron: it is drawn by two horses. In Friesland, and some parts of Holstein, the Dutch swing-plough is used. The common waggon is a heavy clumsy machine on low wheels (fig. 69.) The theoretical agriculturists are well acquainted with all the improved implements of Britain, and some of them have been introduced, especially in Holstein, Hanover, and Westphalia; but these are nothing in a general view. Horses are the most common animals of labor in the north and west of Germany, and oxen in the south. Fallows are rarely well cultivated; and nothing can be worse than the mode of resting lands, and leaving them to be covered with weeds during two or three years in succession.

69



554. *Of the live stock of Germany*, the best breeds of working horses and of oxen are in Holstein, and some districts between Hamburg and Hanover. The best saddle-horses are reared in Hungary. There are also excellent oxen and cows reared in that country, and exported to Italy and Turkey. The best sheep are in Saxony and Prussia, where the Spanish breed has been naturalised. Swine are common; but the breed is every where very indifferent. Goats are reared in the mountains; and also asses and mules. The forests are stocked with wild deer, boars, stags, hares, and other game. Fish are carefully bred and fattened in some places, especially in Prussia; and poultry is every where attended to and carried to a high degree of luxury at Vienna. Bees are attended to in the neighborhood of the forests; and silkworms in the southern districts, as far as Presburg. Canary and other singing birds are reared in Westphalia, and exported to most parts of Europe.

555. *The culture of forests* is particularly attended to in Germany, for the same reasons as in France, and the details in both countries are nearly the same. The number of German books on *Forst-Wissenschaft* is astonishing, and most of the writers seem to consider woodlands in that country as a more eligible source of income than any other.

556. *The common agriculture of Germany* may be considered as every where in a state of gradual improvement. Both governments and individuals have formed institutions for its promotion by the instruction of youth in its principles and most enlightened practices; or for the union of men of talent. The Imperial Society of Vienna; the Georgical Institution of Presburg, and that of Professor Thaer, in Prussia, may be mentioned as recent efforts. The farmers in Germany are particularly deficient in breeding and rearing of horses, cattle, sheep, and swine. Of the two latter, they require new breeds from judicious crosses; and the former require also selection, and much more care in rearing. The implements of husbandry require also to be improved, and the importance of working fallows in a very different manner from what is now done inculcated. If peace continues, there can be no doubt that these, and every other amelioration, will go rapidly forward, for the spirit of agricultural improvement is at present, perhaps, more alive in Germany than in any other country of Europe.

557. *In noticing some traits of agriculture in the different states* of Germany, we shall begin with Denmark at the most northerly extremity, and proceed in the order of geographical position, to Hungary in the south.

SUBSECT. 2. *Agriculture of the Kingdom of Denmark, including Greenland and Iceland.*

558. *The improvement of the agriculture of Denmark* may be dated from 1660, when the king became deposite, and was enabled to carry measures of national benefit into execution without the jarring interference of councils. The slaves of the crown were

immediately made free, and the example followed by several wealthy proprietors. Acts were passed for uniting and consolidating landed property by equitable exchanges; and for preventing the right of free way: both which led to enclosures, draining, and irrigation. There are now better meadows, and more hedges and walls in Denmark than in any country of Germany of the same extent. Various institutions for instruction and reward were formed, and among others, in 1686, the first veterinary school founded in Germany. Artificial grasses and herbage plants enter into most rotations, and rye-grass is perhaps more sown in Holstein than any where, excepting in England. In a word, considering the disadvantages of climate, the agriculture of Denmark is in a more advanced state than that of any other kingdom of Germany.

559. *The Danish farm-houses* are described by Dr. Neale, in 1805, as "generally built upon the same plan, having externally the appearance of large barns, with folding doors at each end, and of sufficient size to admit loaded waggons; on one hand are the apartments occupied by the farmer and his family; on the other, the stable, cow-house, dairy, and piggery; in the centre, a large space, set apart for the waggons, ploughs, harrows, and other implements of husbandry; and over head, the granary and hay-loft." As the postmasters are generally farmers, it is customary to drive in at one end; change horses, and then drive out at the other, which is the case in the north of Germany and in Poland, and more or less so in every part of the north of Europe.

560. *Of the farmer's family*, the same accomplished traveller observes, "we were often agreeably surprised at finding the living apartments furnished with a degree of comfort and neatness bordering upon luxury; every article was substantially good in itself, and was preserved in the greatest order and cleanliness. Thus, white muslin curtains, with fringes and draperies, covered the windows; looking glasses and chests of drawers were placed around; excellent large feather beds, and a profusion of the best well bleached linen displayed the industry of the good housewives, while their dinner tables were equally well supplied with damask cloths, and snowy white napkins; and near the doors of the dairies were ranged quantities of large, singularly shaped, brass and copper vessels, bright as mirrors.

561. *The dimensions of some of their buildings*, he says, is surprising; one measured 110 yards long, resembling in extent the area of Westminster Hall. On the tops of their roofs are generally displayed a set of antlers, and a weathercock; on others, two horses' heads are carved out in wood, and announce the rank of the inhabitants; the antlers, or rather bulls' horns, denoting the house of a tenant; and the horses' heads, that of a landed proprietor. This form of building (*fig. 70*) seems to have been adopted from the earliest ages amongst the inhabitants of Northern Germany," as similar ones are described by Joannes Lasicius in the middle of the sixteenth century. (*Travels through Germany, Poland, &c. 13.*)



562. *The rural economy of Greenland and Iceland* has been given, the former by Crantz, and the latter by Sir G. Mackenzie. Only a small part of Greenland produces pasture, and a still smaller part grain. The culture of the last, however, is now given up. Cabbages and turnips grow well in the gardens, and there are some oak trees, brambles, and junipers between the 60° and 65° N. lat. Sir G. Mackenzie thinks potatoes and barley might succeed in some places. There are considerable pasture farms, a good and hardy breed of horses, and herds and flocks of cattle and sheep. Farmers have no leases, but pay rent in kind, and cannot be removed from the land unless it can be proved that they have neglected its culture: that is, they hold on the meyer system. The stock of cattle and sheep are considered as belonging to the soil of the landlord. A tenant may quit his farm whenever he chooses, but must leave the proper amount of stock to be taken by his successor.

### SUBJECT. 3. *Agriculture of the Kingdom of Prussia.*

563. *The agriculture of Prussia* was considerably advanced by its second king, Frederick William, who is said to have imported 16,000 men from Salzburg, and expended 25 millions of francs in building villages and distributing lands among them. His successor, Frederick the Great, after having conquered a peace, made exertions in agriculture as extraordinary as in war and architecture. He drained and brought into cultivation the borders of the lakes of the Netz and the Wasta, and established 3500 families on what was before a marsh. He drained the marsh of Fridburg, and established on it 400 families. He made extensive drainages, enclosures, and other improvements in the mark Brandenburg, and in Pomerania, and built the extensive embankments of Dallast, in Friesland, by which, by degrees, a large tract of land was recovered, which the sea submerged in 1724. He formed a council of woods and waters for managing the national forests, and regulating rivers and lakes. He established the Royal Economical Society of Potsdam, and other societies, and cultivated a farm. He created a market for agricultural produce, by the establishment of manufactures; and, in short, he left nothing unattempted that might benefit his kingdom.

564. *The successors of the great Frederick* have not distinguished themselves as encouragers of agriculture, with the exception of the present king Frederick William I. who about fifteen years ago established the agricultural institution of Moegelin on the Oder, conducted by Von Thaer, justly celebrated in Germany as an agricultural writer. This institution was visited by Jacob in 1819; and from his work we shall give a short account of it.

565. *The agricultural institution of Moegelin* is situated in the country or march of Brandenburg, about forty-five miles from Berlin. The chief professor, Von Thaer, was formerly a medical practitioner at Celle, near Luneburg, in the kingdom of Hanover; and had distinguished himself by the translation of various agricultural works from the French and English, and by editing a *Magazine of Rural Economy*. About 1804, the King of Prussia invited him to settle in his dominions, and gave him the estate of Moegelin to improve and manage as a pattern farm.

566. *This estate consists of 1200 acres.* Thaer began by erecting extensive buildings for himself, three professors, a variety of tradesmen, the requisite agricultural buildings, and a distillery. The three professors are, one for mathematics, chemistry, and geology; one for veterinary knowledge; and a third for botany, and the use of the different vegetable productions in the *Materia Medica*, as well as for entomology. Besides these, an experienced agriculturist is engaged, whose office it is to point out to the pupils the mode of applying the sciences to the practical business of husbandry. The course commences in September. During the winter months, the time is occupied in mathematics, and the first six books of Euclid are studied; and in the summer, the geometrical knowledge is practically applied to the measurement of land, timber, buildings, and other objects. The first principles of chemistry are unfolded. By a good but economical apparatus, various experiments are made, both on a large and small scale. For the larger experiments, the brew-house and still-house, with their respective fixtures, are found highly useful.

567. *Much attention is paid to the analysis of various soils*, and the different kinds, with the relative quantity of their component parts, are arranged with great order and regularity. The classification is made with neatness, by having the specimens of soil arranged in order, and distinguished by different colors. Thus, for instance, if the basis of the soil be sandy, the glass has a cover of yellow paper; if the next predominating earth be calcareous, the glass has a white ticket on its side; if it be red clay, it has a red ticket; if blue clay, a brown one. Over these tickets, others, of a smaller size, indicate by their color the third greatest quantity of the particular substance contained in the soil. This matter may appear to many more ingenious than useful, and savoring too much of the German habit of generalising. The classification of Von Thaer is, however, as much adopted, and as commonly used on the large estates in Germany, where exact statistical accounts are kept, as the classification of Linnæus in natural history, is throughout the civilised world.

568. *There is a large botanical garden*, arranged on the system of the Swedish naturalist, kept in excellent order, with all the plants labelled, and the Latin as well as German names. An herbarium, with a good collection of dried plants, which is constantly increasing, is open to the examination of the pupils, as well as skeletons of the different animals, and casts of their several parts, which must be of great use in veterinary pursuits. Models of agricultural implements, especially of ploughs, are preserved in a museum, which is stored as well with such as are common in Germany, as with those used in England, or other countries.

569. *The various implements used on the farm* are all made by smiths, wheelers, and carpenters, residing round the institution; the workshops are open to the pupils, and they are encouraged by attentive inspection, to become masters of the more minute branches of the economy of an estate.

570. *The sum paid by each pupil* is four hundred rix dollars annually, besides which they provide their own beds and breakfasts. In this country, such an expense precludes the admission of all but youths of good fortune. Each has a separate apartment. They are very well behaved young men, and their conduct to each other, and to the professors, was polite, even to punctilio.

571. *Jacob's opinion of this institution* is, that an attempt is made to crowd too much instruction into too short a compass, for many of the pupils spend but one year in the institution; and thus only the foundation, and that a very slight one, can be laid in so short a space of time. It is, however, to be presumed, that the young men come here prepared with a considerable previous knowledge, as they are mostly between the ages of twenty and twenty-four, and some few appeared to be still older.

572. *The farm at Moegelin* was examined by Jacob in the autumn. The soil is light and sandy, and the climate cold. The wheat was put in the ground with a drill of Thaer's invention, which sows and covers nine rows at once, and is drawn by two horses. The sowing of seed Thaer considers the only circumstance which makes drilling preferable to sowing broad-cast, as far as respects wheat, rye, barley, and oats. The average produce of wheat is sixteen bushels per acre: not much is sown in Prussia, as rye is the bread corn of that country; it produces, with Thaer, twenty-two bushels and a half to the acre. The usual rotation of crops is, potatoes or peas, rye, clover, and wheat. Winter tares are killed by the frost, and the summer species come to nothing, owing to the dry soil and drought. The spurry (*Spergula*) is therefore grown for the winter

food of sheep: it is sown on the stubbles immediately after harvest, and in six weeks furnishes a herbage of which the sheep are very fond, and which is said to be very nutritious. Potatoes are a favorite crop; and the small tubered and rather glutinous ill-flavored sort, common in France and Germany, is preferred, as containing more starch in proportion to bulk, than the large kinds. Thær maintains, that beyond a certain size, the increase of the potatoe is only water and not nutriment. The produce per acre is 300 bushels or five tons, which Thær contends contains more nutriment than twenty tons of turnips, because the proportion of starch in potatoes to that in turnips is more than four to one. The soil is excellent for turnips, but the long series of dry weather, common on the Continent in the beginning of summer, renders them one of the most uncertain of crops.

573. *A brewery and distillery* are the necessary accompaniments of every large farming establishment in Germany. The result of many experiments in the latter, proved that the same quantity of alcohol is produced from 100 bushels of potatoes as from twenty-four bushels of wheat, or thirty-three of barley. As the products of grain, or of potatoes, are relatively greater, the distillery is regulated by that proportion. During the enforcement of the continental system, many experiments were tried in making sugar from native plants. Von Thær found, after many trials, that the most profitable vegetable from which sugar could be made, was the common garden turnip, (of which variety Jacob did not ascertain,) and that whilst sugar was sold at a rix dollar the pound, it was very profitable to extract it from that root. The samples of sugar made during that period from different roots, the processes, and their results, are carefully preserved in the museum, but would now be tedious to describe. They are certainly equal in strength of sweetness, and those refined, in color and hardness, to any produced from the sugar-cane of the tropics.

574. *The improvement of the breed of sheep*, which has been an important object of this establishment, as far as regards the fineness of the wool, has admirably succeeded. By various crosses from select Merinos; by sedulously excluding from the flock every ewe that had coarse wool, and, still more, by keeping them in a warm house during the winter, Von Thær has brought the wool of his sheep to great fineness, far greater than any that is clipped in Spain; but the improvement of the carcase has been neglected; so that his, like all other German mutton, is very indifferent.

575. *The various kinds of wool* have been arranged by Von Thær, with the assistance of the professors of the institution, on cards; and the fineness of that produced from different races of sheep, is discriminated with geometrical exactness. The finest, are some specimens from Saxony, his own are the next. The fine Spanish wool from Leon is inferior to his, in the proportion of eleven to sixteen. The wool from Botany Bay, of which he had specimens, is inferior to the Spanish. He had arranged, by a similar mode, the relative fineness of the wools produced on the different parts of the body of the sheep, so as to bring under the eye, at one view, the comparative value of the different parts of the fleeces; and he had, also, ascertained the proportionate weight of those different parts. The application of optics and geometry, by which the scales that accompany the specimens are constructed, is such as to leave no doubts on any mind of the accuracy of the results. The scales, indeed, show only the fineness, and not the length of the fibre; which is, I believe, of considerable importance in the process of spinning. The celebrity of the Moegelin sheep is so widely diffused, that the ewes and rams are sold at enormous prices to the agriculturists in East Prussia, Poland, and as far as Russia.

576. *The breeding of cows and the management of a dairy* are secondary objects, as far as regards the mere farming; but it is attended to with care, for the sake of the pupils, who thus have before their eyes that branch of agricultural practice, which may be beneficial on some soils, though not adapted to this. The cows are in good order, of an excellent breed; and, considering that they are, like the sheep, fed only on potatoes and chopped straw, are in good condition. They yield when in full milk, from five to six pounds of butter weekly. The custom of killing the calves, when only a fortnight or three weeks old, prevails here as well as elsewhere in Germany. There is no disputing about taste; but though veal is a favorite food in Germany at the tables of the rich, it always seems very unpleasant to an Englishman.

577. *The ploughs* at Moegelin are better constructed than in most parts of Germany. They resemble our common swing-plough, but with a broader fin at the point of the share. The mould-board is constructed on a very good principle, and with great skill; the convexity of its fore-part so gradually changing into concavity at the hinder-part, as to turn the soil completely upside down. The land is cleanly and straightly ploughed to the depth of six and a half or seven inches, with a pair of oxen, whose usual work is about an acre and a quarter each day.

578. *A threshing-machine* is rarely used, and only to show the pupils the principle on which it is constructed, and the effect it produces; but having neither wind nor water machinery to work it, the flail is almost exclusively used, the threshers receive the sixteenth bushel for their labor. The rate of wages to the laborers is four groschen a day, winter and summer, besides which, they are provided with habitations and fuel. The women receive from two to three groschen, according to their strength and



skill. They live on rye-bread or potatoes, thin soup, and scarcely any animal food but bacon, and a very small portion even of that; yet they look strong and healthy, and tolerably clean.

579. *The culture of the vine, and the rearing of the silkworm*, is carried on in the more southerly of the recent territorial accessions which has been made by Prussia. The culture of culinary vegetables is carried on round Erfurth, and other towns furnished with them whose neighborhoods are less favorable for their growth. Garden seeds are also raised at Erfurth, and most of the seedsmen of Germany supplied with them. Anise, canary, coriander, mustard, and poppy seeds, are grown for distillers and others, and woad, madder, teasle, saffron, rhubarb, &c., for dyers and druggists.

580. *The present king of Prussia* has done much for agriculture, and is said to design more, by lessening the feudal claims of the lords; by permitting estates even of knightly tenure to be purchased by burghers and non-nobles; by simplifying the modes of conveyance and investiture; by setting an example of renouncing most of the feudal dues on his vast patrimonial estates; and by making good communications by roads, rivers, and canals, through his extensive territories. (*Jacob's Travels*, &c. 189.)

#### SUBJECT. 4. *Agriculture of the Kingdom of Hanover.*

581. *The agriculture of the kingdom of Hanover* has been depicted by Hodgson as it appeared in 1817. The territory attached to the free town of Hanover previously to its elector being made king of Britain, was very trifling; but so many dukedoms and other provinces have been since added, that it now contains upwards of 11,045 square geographical miles, and 1,314,104 inhabitants.

582. *An agricultural society* was founded in Hanover in 1751, by Geo. II., and about the same time one at Celle in Luneburg. The principal business of the latter was to superintend and conduct a general enclosure of all the common lands; it was conducted by Meyer, who wrote a large work on the subject. The present Hanoverian ministry are following up the plans of Meyer, and, according to Hodgson, are "extremely solicitous to promote agriculture."

583. *The landed property of Hanover* may be thus arranged: One-sixth belongs to the sovereign, possibly three-sixths to the nobles, one-sixth to the corporations of towns and religious bodies, and less than one-sixth to persons not noble. The crown lands are let to noblemen, or rather favored persons, at very moderate rents, who either farm them or sub-let them to farmers. There are six hundred and forty-four noble properties, but few of them with mansions; the proprietors living in towns. For a nobleman to live in the country without being a magistrate, or without holding some office, is looked on as degrading. Hodgson met with only three instances of nobles cultivating their own estates, and then they lived in towns. The farmers of these estates are bauers or peasants, who hold from ten to eighty acres each, at old fixed rents and services long since established, and which the landlord has no power to alter. "It may be from this cause that so few nobles reside in the country. They have in truth no land but what is occupied by other people. The use of these small portions of land on certain conditions, is the property of the occupier, which he can sell, as the stipulated rent and services are the property of the landlord. The bauer has an hereditary right to the use; the landlord an hereditary right to be paid for that use.

584. *The land of religious corporations* is let in the same manner as the crown lands. That of towns is generally divided into very small lots of twelve or ten acres, and let to the townsmen as gardens, or for growing potatoes and corn for their own consumption. Almost every family of the middling and poorer classes in towns as well as in the country has a small portion of land. Most of the towns and villages have large commons, and the inhabitants have certain rights of grazing cows, &c.

585. *The occupiers of land* may be divided into two classes, meyers and leibeigeners. The first occupy from eighty to twenty acres, and pay a fixed corn or money rent, which the landlord cannot alter, nor can he refuse to renew the lease on the death of the occupier. The money rent paid by such farmers varies from seven to twelve shillings per acre. The term leibeigener, signifies a slave, or a person who owns his own body and no more. He also holds his land on fixed terms, independently of the will of his lord. His conditions are a certain number of days' labor at the different seasons of sowing, reaping, &c., bringing home his lord's fuel; supplying coach or cart horses when wanted, and various other feudal services. The stock of the leibeigener is generally the property of the landlord, who is obliged to make good all accidents or deaths in cattle, and to supply the family with food when the crops fail. This wretched tenure the governments of Hanover, Prussia, and Bavaria are endeavoring to mitigate, or do away altogether; and so much has already been done that the condition of the peasants is said to be greatly superior to what it was a century back.

586. *The free landed property* of the kingdom of Hanover lies principally in Friesland and the marsh lands. There it is cultivated in large, middling, and small farms as in England, and the agriculture is evidently superior to that of the other provinces.

587. *The large farmers of Hanover* have in general extensive rights of pasturage; keep large flocks of sheep, grow artificial grasses, turnips, and even flurin; and have permanent pastures or meadows. Sometimes a brewery, distillery, or public house, is united with the farm.

588. *The farm of Coldingen*, within eight miles of Hanover, was visited by Hodgson. It contained two thousand six hundred acres, with extensive rights of pasturage; it belonged to the crown, and was rented by an amptman or magistrate. The soil was a free brown loam, and partly in meadow, liable to be overflowed by a river. The rotation on one part of the arable lands was, 1. drilled green crop; 2. wheat or rye; 3. clover; 4. wheat or rye; 5. barley or pease, and 6. oats or rye. On another portion, fallow, rape, beans, and the cabbage turnip or *kohl-rübe*; flax and oats were introduced. Seven pair of horses and eight pair of oxen were kept as working cattle. No cattle were fattened; but a portion of the land was sub-let for feeding cows.

589. *Of sheep* there were two thousand two hundred, of a cross between the Rhenish or Saxon breed and the Merino. No attention was paid to the carcase, but only to the wool. The "shepherds were all dressed in long white linen coats, and white linen smallclothes, and wore large hats cocked up behind, and ornamented by a large steel buckle. They all looked respectable and clean. They were paid in proportion to the success of the flock, and had thus a considerable interest in watching over its improvement. They received a ninth of the profits, but also contributed on extraordinary occasions; such as buying oil-cake for winter-food, when it was necessary, and on buying new stock, a ninth of the expenses. The head-shepherd had two-ninths of the profits.

590. *Of the workmen* on this farm, some were paid in proportion to their labor. The threshers, for example, were paid with the sixteenth part of what they threshed. Other laborers were hired by the day, and they received about sevenpence. In harvest-time they may make eightpence. Some are paid by the piece, and then receive at the rate of two shillings for cutting and binding an acre of corn.

591. *The farming of the cultivators of free lands* resembles that of England, and is best exemplified on the Elbe, in the neighborhood of Hamburg. A distinguishing characteristic is, that the farm-houses are not collected in villages; but each is built on the ground its owner cultivates. "This," Hodgson observes, "is a most reasonable plan, and marks a state of society which, in its early stages, was different from that of the rest of Germany, when all the vassals crowded round the castle of their lord. It is an emblem of security, and is of itself almost a proof of a different origin in the people, and of an origin the same as our own. So far as I am acquainted, this mode is followed only in Britain, in Holland, on the sea-coast, from the Ems to the Elb, to which Holstein may be added, and the vale of Arno in Italy. It is now followed in America; and we may judge that this reasonable practice is the result of men thinking for themselves, and following their individual interest." (*Travels*, &c. vol. i. p. 247.) We may add that it is also followed in great part of the mountainous regions of Norway, Sweden, and Switzerland. (See *Clarke's Scandinavia and Bakewell's Tarentaise*, &c.)

592. *Many proprietors of free lands near Hamburg* also farm them. Speaking of these farmers, Hodgson observes, "compared with the other farmers of Germany, they live in affluence and splendor. They eat meat three or four times a-day, and instead of being clad in coarse woollen, which has been made by their wives, they wear fine English clothes, and look like gentlemen. Their sons go for soldier officers, and the daughters are said to study the *Journal des Modes*. The proprietors ride into town to take their coffee and play at billiards, and hear and tell the news, and at home they drink their wine out of cut glass, or tea out of china. Their houses are all surrounded by lofty trees and handsomely laid-out gardens; the floors are carpeted, and the windows of plate glass. The dwelling apartments, the barns, and the places for the cattle, are all covered with one immense roof, and every house looks something like a palace surrounded with a little park. The proprietors direct the agriculture, without working a great deal themselves, and resemble much in their hearty manners English farmers.

593. *In Friesland* they use a swing-plough, known in England as the Dutch plough, the mediate origin of the Rotherham plough, and remotely of Small's Scotch plough. Even the cottagers who rent free lands are totally different from the bauers. Their cottages are white-washed; and they have gardens neatly enclosed, planted with fruit-trees, and carefully cultivated. Such is the influence of liberty and security.

594. *The farming of the bauers*, like that of the meyers, is prescribed by the lease, and consists of two crops of corn and a fallow. "Sometimes," Hodgson observes, "they may sow a little clover, lucerne, or spergel (spurry); but they seldom have meadows, and keep no more cattle than is necessary for their work, and those the common lands can feed: sheep are only kept where there are extensive heaths; one or two long-legged swine are common; and poultry. The large farmers sometimes plough with two oxen; but the bauers, except in the sandy districts, invariably use horses. When they are very poor, and have no horses, they employ their cows. Two or more join their stock, and, with a team of four cows, they plough very well. Sometimes they work their land with the spade. The houses of the bauers in Hanover, as in most parts of Germany, are built of whatever materials are most readily come at, put together in the coarsest manner. They are seldom either painted or white-washed, and are unaccompanied by

either yards, rails, gates, gardens, or other enclosures. They seem to be so much employed in providing the mere necessities of life, that they have no time to attend to its luxuries. A savage curiously carves the head of his war-spear, or the handle of his hatchet, or he cuts his own face and head into pretty devices; but no German bauer ever paints his carts or his ploughs, or ornaments his agricultural implements." (Vol. i. 246.)

595. *To improve the agriculture of Hanover*, Hodgson justly observes, "the simplest and most effectual way would be for government to sell all the domains by auction in good-sized farms, as the Prussian government has done in its newly-acquired dominions. This would end in introducing the Northumberland husbandry, to which, according both to Jacobs and Hodgson, the soil and climate are well adapted, and double the present produce would be produced." To these improvements we may suggest another, that of limiting the rank of noble to the eldest son, so as the rest might, without disgrace, engage in agriculture or commerce. This last improvement is equally wanted for the whole of Germany.

#### SUBJECT. 5. *Present State of the Agriculture of Saxony.*

596. *The husbandry and state of landed property in Saxony* has so much in common with that of Hanover and Prussia, that it will only be requisite to notice the few features in which they differ.

597. *The culture of the vine and the silkworm* are carried on in Saxony, and the latter to some extent. The vine is chiefly cultivated in the margravate, or county of Theissen, and entirely in the French manner. (407.) The mulberry is more generally planted and chiefly to separate properties, or fields, or fill up odd corners, or along roads, as in the southern provinces of Prussia and Hanover, and in France.

598. *The wool of Saxony* is reckoned the finest in Germany. There are three sorts, that from the native short-woolled Saxon sheep; that from the produce of a cross between this breed and the Merino; and that from the pure Merino. In 1819, Jacob inspected a flock of pure Merinos, which produced wool that he was told was surpassed by none in fineness, and the price it brought at market. It was the property of the lord of the soil, and managed by the amptman, or farmer of the manorial and other rights. Till the year 1813, it consisted of 1000 sheep; but so many were consumed in that year, first by the French, and next by the Swedes, that they have not been able to replace them further than to 650. The land over which they range is extensive and dry; not good enough to grow flax, but a course of 1. fallow, 2. potatoes, 3. rye or barley, was followed, and the show of the rye and barley with the potatoes, constituted the winter food of the sheep. (*Travels, &c.* p. 265.)

599. *The general rotation of crops in Saxony*, according to Jacob, is two corn crops, and a fallow, or two corn crops and pease. There are some exceptions; and cabbages, turnips, and *kohl rübe* are occasionally to be seen. The plough has two wheels, and is drawn by two oxen; "and sometimes, notwithstanding the Mosaic prohibition, with a horse and a cow." There are some fine meadows on the borders of the brooks near the villages; but they are in general much neglected, and for want of draining yield but coarse and rushy grass. The houses of the farmers are in villages, the largest for the amptman, and the next for the meyers and leibeigeners. "The whole tract of land, from Meissen to within two English miles of Leipsic, is a sandy loam, admirably calculated for our Norfolk four-course system, by which it would be enabled to maintain a great quantity of live-stock, and produce double or treble the quantity of corn it now yields. In the whole distance from Wurzen, about fifteen miles, I saw but three flocks of sheep; two were small, the other, which I examined, consisting of about one thousand ewes, wedders, and tags, belonged to a count, whose name I did not ascertain. As he is lord of a considerable tract of country, the flock has the range of many thousand acres in the summer, and in the winter are fed with chopped straw and potatoes. Upon our system, which might be advantageously introduced, the same quantity of land would maintain ten times as many sheep, and still produce much more corn than it does at present." (*Jacob's Travels*, 301.)

600. *The cows near the villages*, between Meissen and Leipsic, were numerous compared with the sheep, but generally looked poor. "As I saw," continues Jacob, "no hay or corn-stacks in the whole distance, I had been puzzled to conceive in what manner their cows could be supported through the winter. Upon inquiring, I learnt a mode of keeping them, which was quite new to me, but which I cannot condemn. The land is favorable to the growth of cabbages, and abundant quantities are raised, and form a material article of human sustenance; the surplus, which this year is considerable, is made into sour-kraut, with a less portion of salt than is applied when it is prepared as food for man. This is found to be very good for cows, and favorable to the increase of their milk, when no green food, or any thing but straw can be obtained." (*Travels, &c.* 303.)

601. *The land within two miles of Leipsic* is almost wholly in garden-culture, and is vastly productive of every kind of culinary vegetable. The fruit-trees and orchards, notwithstanding many of them showed vestiges of the war, surprised Jacob by their abundance. The inhabitants subsist much less on animal than we do, but a larger quantity of fruit and vegetables is consumed; and hence they have greater inducements to improve their quality, and to increase their quantity, than exist in those rural districts of Great Britain which are removed from the great towns.

602. *Jacob's opinion of the agriculture of Saxony* is, that it is equal to that of Prussia. In one respect he thinks it superior, as no portion of the soil is wholly without some cultivation; but that cultivation is far below what the land requires, and the produce much less than the inhabitants must need for their subsistence.

SUBJECT. 6. *Present State of the Agriculture of the Kingdom of Bavaria.*

603. *Bavaria is one of the most backward countries* of Germany, in regard to every kind of improvement. A bigotted and ignorant priesthood, not content with possessing a valuable portion of the lands of the country, have insisted on the expulsion of the protestants, and on the strict observance of the endless holidays and absurd usages which impede the progress of industry among their followers. "Hence a general habit of indolence and miserable backwardness in all arts, and especially in agriculture; and in point of learning, a complete contrast to the north of Germany." During the electorate of Bavaria, one of its electors, contemporary with Joseph II. of Austria, desirous of introducing improvements, abolished monastic orders in some parts of his dominions; but the people were by no means ripe for such a change, notwithstanding the existence of masonic societies, supposed (but ignorantly) to have rendered them ripe for any sort of revolution.

604. *The surface of Bavaria* is mountainous toward the south; the ground rising in the direction of the Alps, and containing a number of lakes and marshes, with little that has as yet been brought under tillage. To the northward are extensive plains, and also wooded mountains. Indeed, the greater part of the country is either in mountain or underwood.

605. *The crops cultivated* are the usual corns, legumes, and roots; but potatoes and turnips are not very common. Excellent wine is produced on the hills; but little silk or maize even in the warmest parts.

606. *Improvements*, we are told, are now taking place even in Bavaria.

SUBJECT. 7. *Present State of the Agriculture of the Empire of Austria.*

607. *Agriculture is in a very backward state throughout the whole of the Austrian dominions.* The soil, surface, and climate are almost every where favorable for husbandry; but the political circumstances of the country, and the ignorance of its inhabitants, which is greater than in most other parts of Germany, have kept it in nearly a fixed state for several centuries. Various attempts have been made during the eighteenth century to improve the condition of the peasantry, and simplify the laws relating to landed property, especially by Joseph II.; but they have produced no effect, chiefly, as it appears, because too much was attempted at once. There are agricultural societies at Vienna, Pesth, Prague, and other places; and a very complete agricultural school or georgicon has been established at Kesztheley in Hungary, by a highly patriotic individual, Graf Festetits. A copious account of it has been given by Dr. Bright (*Travels in Hungary*, in 1814. 361. et seq.), by which it appears considerably more extensive than those of Hofwyl or Moegelin.

608. *The landed property of Austria* is under similar circumstances of division and occupation with that of the rest of Germany. Perhaps the number of large estates is greater in proportion to the small properties. In Hungary they are of immense extent, and cultivated almost entirely by their proprietors. "In considering a Hungarian property," Dr. Bright observes, "we must figure to ourselves a landed proprietor possessing ten, twenty, or forty estates, distributed in different parts of the kingdom, reckoning his acres by hundreds of thousands, and the peasants upon his estates by numbers almost as great; and remember, that all this extent of land is cultivated, not by farmers, but by his own stewards and officers, who have not only to take care of the agricultural management of the land, but to direct, to a certain extent, the administration of justice amongst the people: and we must further bear in mind, that perhaps one-third of this extensive territory consists of the deepest forests, affording a retreat and shelter, not only to beasts of prey, but to many lawless and desperate characters, who often defy, for a great length of time, the vigilance of the police. We shall then have some faint conception of the situation and duties of a Hungarian magnat."

609. *To conduct the business of such extensive domains*, a system of officers is formed, and governed by a court of directors; and on well-regulated estates, this band of managers exhibit, in their operations, all the subordination of military, and the accuracy of mercantile concerns. For this purpose an office is established at or near the estate on which the magnat resides, in which a court of directors is held at stated periods, usually once a week. This court consists of a president or plenipotentiary, a director or solicitor, a prefect, auditor, engineer or architect, a fiscal for law affairs, the keeper of the archives, besides a secretary, clerks, &c. Its business is to review all that has taken place on the different estates, whether of an economical or judicial nature, to examine accounts, and regulate future proceedings. The steward of each separate estate

has also a weekly court. It consists of the fiscal or lawyer, the bailiff, the forest master, the engineer, the treasurer, foremen and sub-foremen, police officers to guard prisoners and keep them at work, forest keeper, rangers, and a gaoler. The estates of Prince Esterhazy, which are the largest in Europe; of Graf Festetics, and Prince Balhyani, are examples of this mode of government and culture; of which it may be observed, that, like many German plans, it is very accurate and systematic, but very unproductive of profit.

610. *The crown has immense tracts of lands*, especially in Galicia; and, independently of these, the personal estates of the reigning family amount to upwards of 100,000*l.* sterling a year, all of which are farmed by stewards. In the Moravian, Bohemian, and Austrian districts, however, where the estates are not so large as in Hungary, and the people rather in better circumstances as to property and knowledge, they are frequently farmed on the meyer system.

611. *The Austrian dominions*, like the rest of Germany, are unenclosed, with the usual exceptions; the farm-houses and cottages are usually built of wood, and thickly covered with thatch or with shingles. The cottages are remarkably uniform in Hungary, and village scenery there, according to Dr. Bright, must be the dullest in Europe. Not less so is their cultivated plains: speaking of a plain near Presburg, he says,

“The peasants were employed in ploughing the land, and my driver (*fig. 71.*) cheered the way by a Slavonian song. But let no one be induced, by these expressions, to figure to his imagination a scene of rural delight. The plain is unenlivened by trees, unintersected by hedges, and thinly inhabited by human beings; a waste of arable land, badly cultivated, and yielding imperfect crops to proprietors, who are scarcely conscious of the extent of territory they possess. It is for some branch of the families of Esterhazy or Palfy, known to them only by name, that the Slavonian peasants who inhabit these regions are employed. Their appearance bespeaks no fostering care from the superior,—no independent respect, yielded with free satisfaction from the inferior. It is easy to perceive that all stimulus to invention, all incitement to extraordinary exertion, is wanting. No one peasant has proceeded in the arts of life and civilisation a step farther than his neighbor. When you have seen one, you have seen all. From the same little hat, covered with oil, falls the same matted long black hair, negligently plaited, or tied in knots; and over the same dirty jacket and trowsers is wrapped on each a cloak of coarse woollen cloth, or sheepskin still retaining its wool. Whether it be winter or summer, week-day or sabbath, the Slavonian of this district never lays aside his cloak, or is seen but in heavy boots.

612. *Their instruments of agriculture* (*fig. 72.*) are throughout the same; and in all their habitations is observed a perfect uniformity of design. A wide, muddy road separates two rows of cottages, which constitute a village. From amongst them, there is no possibility of selecting the best or the worst; they are absolutely uniform. In some villages the cottages present their ends; in others, their sides to the road; but there is seldom this variety in the same village. The interior of the cottage is in general divided into three small rooms on the ground floor, and a little space in the roof destined for lumber. The roof is commonly covered with a very thick thatch; the walls are white-washed, and pierced towards the road by two small windows. The cottages are usually placed a few yards distant from each other. The intervening space, defended by a rail and gate, or a hedge of wicker-work towards the road, forms the farm-yard, which runs back some way, and contains a shed or outhouse for the cattle. Such is the outward appearance of the peasant and his habitation. The door opens in the side of the house into the middle room, or kitchen, in which is an oven, constructed of clay, well calculated for baking bread, and various implements for household purposes, which generally occupy this apartment fully. On each side of the room is a door, communicating on one hand with the family dormitory, in which are the two windows that look into the road. This chamber is usually small, but well arranged; the beds in good order, piled upon each other, to be spread out on the floor at night; and the walls covered with a multiplicity of pictures and images of our Saviour, together with dishes, plates, and vessels of coarse earthenware. The other door from the kitchen leads to the store-room, the repository of the greater part of the peasant's riches, consisting of bags of grain of various kinds, both

71



72

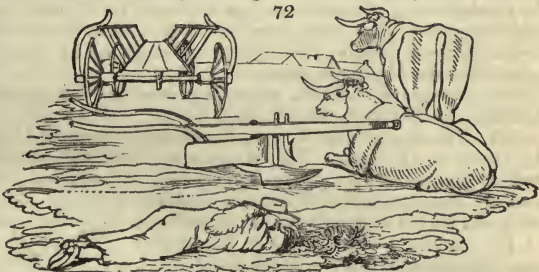

for consumption and for seed, bladders of tallow, sausages, and other articles of provision, in quantities which it would astonish us to find in an English cottage. We must, however, keep in mind, that the harvest of the Hungarian peasant anticipates the income of the whole year; and, from the circumstances in which he is placed, he should rather be compared with our farmer than our laborer. The yards or folds between the houses are usually much neglected, and are the dirty receptacles of a thousand uncleanly objects. Light carts and ploughs (fig. 72.), with which the owner performs his stated labor, — his meagre cattle, — a loose rudely formed heap of hay, — and half a dozen ragged children, — stand there in mixed confusion; over which three or four noble dogs, of a peculiar breed, resembling in some degree the Newfoundland dog, keep faithful watch." (*Trav. in Hung. &c.* 19.)

613. *The agricultural produce of Austria* is the most varied of any part of Germany. Excellent wheat is cultivated in Galicia, where the soil is chiefly on limestone, and in the adjoining province of Buckowine; and from both immense quantities are sent down the Vistula to Dantzic. Wheat, rye, and all the other corns, are grown alike in every district, and the quantity might be greatly increased if there were a sufficient demand. Maize is cultivated in Hungary and Transylvania; millet in Hungary, Sclavonia, and Carinthia; and rice in the marshy districts of Temeswar. Tobacco is extensively cultivated in Hungary, and excellent hops are produced in Moravia and Bohemia. It is estimated that about a sixth part of the Austrian dominions is under tillage. The most common rotation is two corn crops, and fallow or rest.

614. *The vine* is cultivated to the greatest extent in Hungary. The well known Tokay is raised on the last chain of the Carpathian hills in the neighborhood of the town of Tokay. The district extends over a space of about twenty English miles. "Throughout the whole of this country it is the custom to collect the grapes which have become dry and sweet, like raisins, whilst hanging on the trees. They are gathered one by one; and it is from them alone that the prime Tokay, or, as it is termed, Tokay Ausbruch, is prepared, which, in 1807, sold for 100 florins the cask of 180 halbes on the spot. They are first put together in a cask, in the bottom of which holes are bored to let that portion of the juice escape which will run from them without any pressure. This, which is called Tokay essence, is generally in very small quantity, and very highly prized. The grapes are then put into a vat, and trampled with the bare feet, no greater pressure being permitted. To the squeezed mass is next added an equal quantity of good wine, which is allowed to stand for twenty-four hours, and is then strained. This juice, without further preparation, becomes the far-famed wine of Tokay, which is difficult to be obtained, and sells in Vienna at the rate of 12*l.* sterling per dozen. The greater part of these vineyards is the property of the emperor; several, however, are in the hands of nobles." (*Bright's Travels.*)

615. *Another species of Hungarian wine*, called Mèneser, is said to equal Tokay; next to that in value comes the wines of Edenburg, Rusth, St. Gyorgy, and Ofen, followed by a great variety, whose names are as various as the hills which produce them. The grape which is preferred for making the Tokay and other Hungarian wines of that character, is a small black or blue grape, figured and described by Sickler in his *Garten Magazine* of 1804, as the Hungarian blue.

616. *Plums* are cultivated, or rather planted and left to themselves; and an excellent brandy is distilled from the fermented fruit.

617. *The culture of silk* is in the least flourishing state in Hungary; but succeeds well in Austria and Moravia. That of cotton was tried, but left off chiefly on account of the unfavorableness of the autumns for ripening the capsules. The mountain rice (*Oryza mutica*), from the north of China, was cultivated with success, but neglected during the late wars. "The greatest advantages which it promised arose from the situations in which it would flourish, and the fact of its not requiring marshy lands, which are so destructive to the health of those who are engaged in the cultivation of common rice." The rhus cotinus is extensively collected from the wastes, and used as a tanning plant, especially in the preparation of morocco leather. Woad is cultivated as a substitute for indigo; the cyperus esculentus (fig. 73 a.), and the astragalus bœticus, (b), as substitutes for coffee; the seeds of the latter, and the tubers of the former, being the parts used. The acer campestre, platanoides, and pseudo-platanus, have been tapped for sugar, and the *A. saccharinum* extensively cultivated for the same purpose, but without any useful result. It was found cheaper to make sugar from the grape. The culture of coffee, olives, indigo, and other exotics, has been tried, but failed.



618. *The rearing and care of bees* was much attended to during the latter part of the eighteenth century. A public school was opened at Vienna, and some in the provinces; and great encouragement was given to such as kept hives. Some proprietors in Hungary possessed 300 stock-hives. It is customary there to transport them from place to place, preferring sites where buckwheat or the lime-tree abounds. The honey, when procured, is greatly increased in value by exposure to the open air for some weeks during winter; it then becomes hard, and as white as snow, and is sold to the manufacturers of liquors at a high price. The noted Italian liqueur, *rosoglio*, made also in Dantzic, is nothing more than this honey blanched by frost, and spirit: though the honey used is said to be that of the lime-tree, which is produced only in the forests of that tree near Kowno on the Nicmen, and sells at more than three times the price of common honey.

619. *The live stock of Austria* consists of sheep, cattle, horses, pigs, and poultry. Considerable attention has lately been paid to the breeding of sheep, and the Merino

breed has been introduced on the government estates, and those of the great proprietors. The original Hungarian sheep (*Ovis strepsiceros*) (fig. 74.) bears upright spiral horns, and is covered with a very coarse wool. "Improvement on this stock by crosses," Dr. Bright informs us, "is become so general, that a flock of the native race is seldom to be met with, excepting on the estates of religious establishments." Baron Giesler has long cultivated the Merino breed in Moravia. In Hungary, Graf Hunyadi has



paid great and successful attention to them for upwards of twenty years. His flock, when Dr. Bright saw it in 1814, amounted to 17,000, not one of which whose family he could not trace back for several generations, by reference to his registers.

620. *The horned cattle of the Austrian dominions* are of various breeds, chiefly Danish and Swiss. The native Hungarian breed are of a dirty white color, large, vigorous, and active, with horns of a prodigious length. The cow is deficient in milk; but where dairies are established, as in some places near Vienna, the Swiss breed is adopted.

621. *The Hungarian horses* have long been celebrated, and considerable attempts made from time to time to improve them by crosses with Arabian, English, and Spanish breeds; and, lately, races have been established for this purpose. The imperial breeding shed, or huras of Mezöhegyes, established in 1783, upon four commons, is the most extensive thing of the kind in Europe. It extends over nearly 50,000 acres; employs 500 persons; and contains nearly 1000 breeding mares of Besarabian, Moldavian, Spanish, or English extraction.

622. *The breed of swine* in some parts of Hungary is excellent.

623. *Poultry* are extensively reared near Vienna, and also frogs and snails. Townson has described at length the method of treating these reptiles, and of feeding geese for their livers. (*Travels in Hungary in 1796.*)

624. *The land tortoise* likewise occurs in great numbers in various parts of Hungary, more particularly about Fuzes-Gyarmath, and the marshes of the river Theiss; and being deemed a delicacy for the table, is caught and kept in preserves. The preserve of Kesztheley encloses about an acre of land, intersected by trenches and ponds, in which the animals feed and enjoy themselves. In one corner was a space separated from the rest by boards two feet high, forming a pen for snails. The upper edge of the boards was spiked with nails an inch in height, and at intervals of half an inch, over which these animals never attempt to make their way. This snail (*Helix pomatia*) (fig. 75 a.) is in

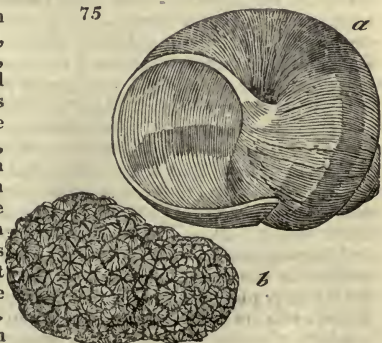

great demand in Vienna, where sacks of them are regularly exposed to sale in the market, alternating with sacks of beans, lentils, kidneybeans, and truffles. (*fig. 75 b.*)

625. *The implements and operations* of the agriculture of Austria differ little from those of Saxony. Dr. Bright has given a figure of the Hungarian plough and cart, (*fig. 72.*), and blames their mode of depositing their corn in holes in the ground, lined with straw, by which it acquires a strong mouldy smell. Vineyards are carefully dug and hoed, and the shoots of the vines, in places where the winter is severe, laid down and covered with earth to protect them from the frost. Many of the great proprietors are introducing the most improved British implements on their estates, and some have taken ploughmen from this country to instruct the natives in their use. Prince Esterhazy has English gardeners, bailiffs, grooms, and other servants.

626. *The forests of the Austrian dominions* are chiefly in Hungary, and on the borders of Galicia on the Carpathian mountains. They contain all the varieties of needle or pine-leaved, and broad leaved-trees, which are indigenous north of the Rhine. The oaks of Hungary are perhaps the finest in Europe. The forest of Belevar on the Drave, was visited by Dr. Bright. It consists chiefly of different species of oak, the most luxuriant he ever beheld. Thousands measured at several feet above the root, more than seven feet in diameter; continue almost of the same size without throwing out a branch, to the height of thirty, forty, and fifty feet, and are still in the most flourishing and healthy condition. Timber there is of little value, excepting for the buildings wanted on the estate, or for hoops and wine barrels. In some cases the bark is not even taken from oak-trees; but in others the leaf galls, and the Knopperrn, or smaller galls, which grow on the calyx of the acorn, are collected and exported for being used in tanneries.

627. *The improvement of the agriculture* of Austria seems anxiously desired both by the government and the great proprietors. Various legislative measures are accordingly adopted from time to time, societies formed and premiums offered. These will no doubt have a certain quantum of effect; but the radical want, in our opinion, is information and taste for comfortable living among the lower classes; and this can only be brought about by the general diffusion of village schools; and by establishing easy rates, at which every peasant might purchase his personal liberty or freedom from the whole, or a certain part of the services he is now bound to render his lord.

#### SECT. VI. *Of the present State of Agriculture in the Kingdom of Poland.*

628. *Poland was formerly called the granary of Europe*; but this was when its boundaries extended from the Baltic to the Black Sea; and when the Ukraine and Lithuania were included. At present its limits are so circumscribed, and its arable surface so indifferently cultivated, or naturally so infertile, that the kingdom of Poland, strictly speaking, furnishes little more corn than supplies its own population. The immense supplies of wheat sent to Dantzic are chiefly from the detached provinces of Galicia, united to Austria, and from Volhynia and Podolia, now belonging to Russia.

629. *The landed estates* of Poland are almost every where large, and either belong to the crown, to the nobles, or to religious corporations. They are farmed by the proprietors, by means of stewards; or let out in small portions on the meyer or leibeigener tenure. There are scarcely any free farmers or cottagers. Buonaparte passed an edict, while Poland was under his protection as a duchy, to annul the leibeigener tenure; but it is said the peasants were too much afraid to trust to their own industry to take advantage of it; and it was never carried into effect. The nobles have generally houses on their estates, which they occupy, at least, part of the year; at other periods it is taken care of by the steward, who is always admitted at the table of his lord, being himself what is called of noble descent. The estates of religious houses are of great extent: they are sometimes let to nobles or others on a corn rent, who generally sublet them; and in a few cases they are farmed by the corporation. The postmasters on the different main roads invariably rent a considerable portion of land for the support of their horses. Most of these are meteyers, but some are free men, and pay a money rent; and there are one or two instances of nobles farming the post.

630. *The houses and offices of these noble postmasters* (*fig. 76.*) afford the only distant resemblance to a British farm-yard, that is to be met with in Poland. The farmhouse and farmery of the peasant postmaster are both included in an immense shed or barn, with a small apartment at one end for the master's dwelling, the remaining space divided for live stock and implements of every description, and for the cattle, carriages, and lodging place of travellers who may stop during night. Most of these places are sufficiently wretched as inns, but in the present state of things they answer very well for the other purposes to which they are applied, and are superior to the hovels of the farmers who are not postmasters, and who are clustered together in villages, or in the outskirts of towns. Some villages, however, in the south of Poland are almost entirely



76

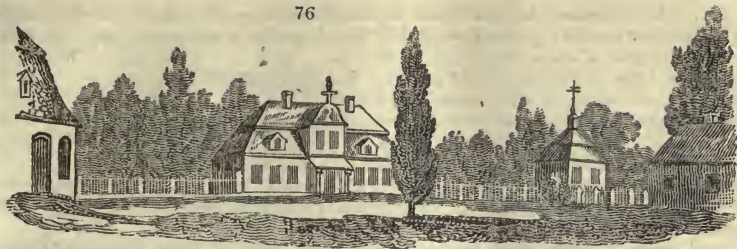

composed of Jews ; there the houses are generally of a superior construction, (fig. 77.),

77



but still on the same general plan of a living room at one end of a large barn, the main area of which serves for all the purposes of a complete farmery. The buildings in Poland, excepting those of the principal towns, are constructed of timber and covered with shingles. The sheds and other agricultural buildings are boarded on the sides ; but the cottages are formed of logs joined by moss or clay ; of frames filled up with wicker work and clay ; or of other modes and materials still more rude. The commonest kind have no chimnies or glass windows.

631. *The climate of Poland*, though severe, is much less precarious than that of the south of Germany or of France. A winter of from five to seven months, during the greater part of which time the soil is covered with snow, is succeeded by a rapid spring and warm summer ; and these are followed by a short cold wet autumn. Under such a climate good meadows and pastures cannot be expected ; but arable culture is singularly easy on free soils, which the frost has rendered at once clear from most sorts of weeds, and soft and mouldy on the surface.

632. *The surface of Poland* is remarkably even, and *the soil* almost every where sandy to a great depth. In many places this sand is calcareous, and produces abundance of white clover naturally ; in others it is sterile, and only produces heath or stunted shrubs. On the borders of some of the rivers, as the Bog and the Narew, it is marshy, and abounds in acorus, iris, typha, and other aquatics or marsh plants. In no part of the present kingdom of Poland can it be called either hilly or stony, unless we except some parts on the borders of Silesia and Gallicia. It is almost needless to observe, that enclosures are rarely seen in Poland. To the traveller, passing through the country, it appears an interminable forest, with here and there glades of coarse pasture, or small tracts of ploughed ground.

633. *The arable culture of Poland* is abundantly simple : the course of crops is, in most places, 1st, wheat, barley, or rye ; 2d, oats ; 3d, fallow, or several years rest to commence with fallow. In a very few places clover is sown, and also beans or pease, but only in small quantities. The *digitaria sanguinalis* is sown as a plant of luxury in a few places, and the seeds used as rice : the buckwheat is also sown, and the seeds ground and used as meal. Almost every farmer sows linseed or hemp, to the extent required for home use, and some for sale. Rye is the bread corn of the country. Potatoes are now becoming general ; and succeed well in every part of the country. The mangold, or white beet, was cultivated in many places in 1811 and 1812, by order of Buonaparte, in order that the natives might grow their own sugar ; but that is now left off, and the peasants have not even learned its value as a garden plant, producing chard and spinnage. Turnips or cabbages are rarely seen even in gardens ; few of the cottagers, indeed, have any garden ; those who have, cultivate chiefly potatoes, and kohl rübe. Many species of mushrooms grow wild in the woods and wastes, and most of these are carefully gathered, and cooked in a variety of ways as in Russia. The wastes or common pastures are left entirely to nature. There are some tracts of indifferent meadow on the Vistula, at Warsaw, Thorn, and Cracovie, and some on the tributary streams, which afford a tolerable hay in summer, and would be greatly improved by draining.

634. *The implements and operations* are incredibly rude. We have seen lands ploughed (after their manner) by one cow, tied by the horns to a sharpened pole; in other instances a pair of oxen drag a wretched implement (*fig. 78.*) formed by the peasant, who is in all cases his own plough and wheel-wright, as well as house carpenter and builder. Their best or usual plough has no mould-board; and the crop is in many cases more indebted to the excellence of the soil, and the preceding winter's frost, than to the farmer. Horses are their general beasts of labor; their harness is very rude, often of straw ropes, and twisted willow shoots. The body of their best market carts, in which even the lesser nobles visit each other, are of wicker-work (*fig. 79.*), and the axle and wheels are made without any iron.

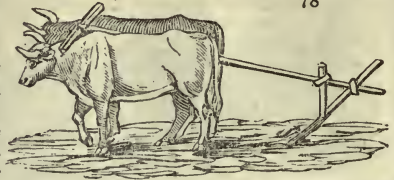

79



635. *The live stock* consists chiefly of horses: there are few oxen; not many cows, and very few sheep. Poultry are abundant, and swine; but the latter of the yellow long-legged breed. The horses are very hardy animals, and of better shapes than might be expected from their treatment. Warsaw and Cracow are supplied with beef and veal, chiefly from the Ukraine. Mutton is little used.

636. *The extensive forests of Poland* are little attended to, excepting on the banks of the principal rivers, and where oak abounds, from which bark and wheel spokes may be procured. These are cut over regularly at intervals, and standards left in the usual way. The wild or Scotch pine forests, are the most extensive; these perpetuate themselves by semination; and the trees are often so crowded as to be of little use but as fuel. The chief proprietor of these forests is the crown, and the religious corporations, who, whenever they can find purchasers, are glad to let them thin out the best trees at a certain rate, and float them down the nearest stream, to the Vistula Pregel or Niemen. A good deal has been said about the importance of felling timber at particular seasons. In Poland, the operation generally takes place in summer, but not, as far as we could learn, from any regard to the effect on the timber. The trees are often notched half through a year or two before, in order to obtain rosin. The other products of forests, as fuel, charcoal, ashes, hoops, poles, &c. are obtained in the usual manner. Game is abundant in them, and bears, polecats, &c. are to be seen in some places.

637. *The management of bees* is a material article in the forest culture of Poland. The honey is divided into three classes, namely lipiec, leszny, and stepowey prasznyrd, thus described by How. (*Gen. Rep. Scot. app.*)

638. *Lipiec* is gathered by the bees from the lime-tree alone, and is considered on the Continent most valuable, not only for the superiority of its flavor, but also for the estimation in which it is held as an arcumum, in pulmonary complaints, containing very little wax, and being consequently less heating in its nature; it is as white as milk, and is only to be met with in the lime-forests, in the neighborhood of the town of Kowno, in Lithuania. The great demand for this honey occasions it to bear a high price, inasmuch, that a small barrel, containing hardly one pound weight, has been known to sell for two ducats on the spot. This species of the lime-tree is peculiar to the province of Lithuania; and is quite different from all the rest of the genus *tilia*, and is called *Kamienna lipsa*, or stone-lime. The inhabitants have no regular bee-hives about Kowno; every peasant who is desirous of rearing bees, goes into the forest and distinct belonging to his master, without even his leave, makes a longitudinal hollow, aperture or apertures in the trunk of a tree, or in the collateral branches, about three feet in length, one foot broad, and about a foot deep, where he deposits his bees, leaves them some food, but pays very little further attention to them, until late in the autumn; when, after cutting out some of their honey, and leaving some for their maintenance, he secures the aperture properly with clay and straw against the frost and inclemency of the approaching season; these tenements (if they may be so called), with their inhabitants, and the produce of their labor, are then become his indisputable property; he may sell them, transfer them; in short, he may do whatever he pleases with them; and never is it heard that any depredation is committed on them, (those of the bear excepted). In Poland, the laws are particularly severe against robbers or destroyers of this property, punishing the offender, when detected, by cutting out the navel, and drawing out his intestines round and round the very tree which he has robbed.

639. *When spring arrives*, the proprietor goes again to the forest, examines the bees, and ascertains whether there is sufficient food left, till they are able to maintain themselves; should there not be a sufficient quantity, he deposits with them as much as he judges necessary till the spring blossom appears. If he observes that his stock has not decreased by mortality, he makes more of these apertures in the collateral branches, or in the trunk of the tree, that in case the bees should swarm in his absence, they may have a ready asylum. In the autumn he visits them again, carries the June and July work away with him, which is the lipiec, and leaves only that part for their food which was gathered by them before the commencement, and after the decay of the flowering of the lime-tree.

640. *The leszny, the next class of honey*, which is inferior in a great degree to the lipiec, being only for the common mead, is that of the pine forests; the inhabitants of which make apertures in the pine-trees, similar to those near Kowno, and pay the same attention, in regard to the security of the bees, and their maintenance. The wax is also much inferior in quality; it requires more trouble in the bleaching, and is only made use of in the churches.

641. *The third class of honey is the stepowey prasznyrd*, or the honey from meadows or places where there is an abundance of perennial plants, and hardly any wood. The province of Ukraine produces the very best, and also the very best wax. In that province the peasants pay particular attention to this branch of

economy, as it is the only resource they have to enable them to defray the taxes levied by Russia; and they consider the produce of bees equal to ready money; wheat, and other species of corn, being so very fluctuating in price, some years it being of so little value, that it is not worth the peasant's trouble to gather it in: this has happened in the Ukraine, four times in twelve years: but honey and wax having always a great demand all over Europe, and even Turkey, some of the peasants have from four to five hundred uler, or logs of wood in their bee-gardens, which are called *pasteka*, or bee-hives; these logs are about six feet high, commonly of birch wood, (the bees prefer the birch to any other wood,) hollowed out in the middle for about five feet; several lamina of thin boards are nailed before the aperture, and but a small hole left in the middle of one of them, for the entrance of the bees. As the bees are often capricious at the beginning of their work, frequently commencing it at the front rather than the back, the peasants cover the aperture with a number of these thin boards, instead of one entire board, for fear of disturbing them, should they have begun their work at the front. It may appear extraordinary, but it is nevertheless true, that in some favorable seasons, this aperture of five feet in length, and a foot wide, is full before August; and the peasants are obliged to take the produce long before the usual time, with the view of giving room to the bees to continue their work, so favorable is the harvest some summers.

642. *The process of brewing mead in Poland* is very simple: the proportion is three parts of water to one of honey, and 50 lb. of mild hops to 163 gallons, which is called a *waar*, or a brewing. When the water is boiling, both the honey and hops are thrown into it, and it is kept stirring until it becomes milk warm; it is then put into a large cask, and allowed to ferment for a few days; it is then drawn off into another cask, wherein there has been aqua-vitæ, or whisky, bunged quite close, and afterwards taken to the cellars, which in this country are excellent and cool. This mead becomes good in three years time; and by keeping, it improves like many sorts of wine. The mead for immediate drink is made from malt, hops, and honey, in the same proportion, and undergoes a similar process. In Hungary, it is usual to put ginger in mead. There are other sorts of mead in Poland, as *wisniak*, *dereniak*, *maliniak*; they are made of honey, wild cherries, berries of the *cornus mascula*, and raspberries; they all undergo the same process, and are most excellent and wholesome after a few years keeping. The *lipiec* is made in the same way; but it contains the honey and pure water only. The honey gathered by the bees from the *azalea pontica*, at *Oczakow*, and in *Potesia* in Poland, is of an intoxicating nature; it produces nausea, and is used only for medical purposes, chiefly in rheumatism, scrophula, and eruption of the skin, in which complaints it has been attended with great success. In a disease among the hogs called *wengry*, (a sort of plague among these animals,) a decoction of the leaves and buds of *azalea* is given with the greatest effect, and produces almost instantaneous relief. The disease attacks the hogs with a swelling of their throat, and terminates in large hard knots, not unlike the plague, on which the decoction acts as a digestive, abates the fever directly in the first stage, and suppurates the knots. It is used in Turkey, with the same view, the cure of the plague.

643. *Such is the present state of agriculture in Poland*, as it appeared to us in 1813; but it must always be recollected, that it does not include either that of Lithuania, or of Galicia, which is of a much superior description. Since the middle of the 18th century some of the principal Polish nobles have occasionally made efforts for the improvement of the agriculture of their country; but they have not been designed and directed in the best manner, and what is much worse, not steadily pursued. Splendid wooden houses and villages have been built, and foreign farmers induced to settle and cultivate the lands. In the first heat of the business, all went on well; but the proprietors soon began to cool, to neglect their new tenants, and leave them to the mercy of their stewards, who, in Italy and Poland, are known to be the most corrupt set of men that can be met with. The oppression of these stewards, and the total disregard of their masters to their promises and agreements made to and with these strangers, have either forced the latter to return home, or reduced them to the necessity of becoming servants in the towns, or in Germany; and we know of instances where it has ruined men of some property. There are one or two exceptions; but we could produce names and dates in proof of the general truth of what we have asserted. The failure of a dairy establishment, and of a brewery, both established before the commencement of the French revolution, is attributable to this sort of conduct in the proprietors.

644. *The efforts to introduce a better culture into Poland since the peace*, have been more general, and conducted on more moderate and rational principles. British implements have been imported in considerable numbers, and even six or more threshing machines. Improved breeds of cattle and sheep have been procured from Prussia and Saxony; scientific managers are obtained from the German agricultural schools, and what will contribute essentially to improvement, encouragement is given to foreigners to settle by letting or selling the crown lands, at moderate rates, and not only free from all feudal services for ever, but for a certain period exempted from government taxes. Add to this, that the *leibeigenen* and *meyers* of every description may buy up the services which they now render their lords, at very easy rates established by law; and thus, according to their ambition and means, render themselves partially or wholly free-men. In short, the most judicious measures have been taken by the new government of Poland, for the improvement of the country; and they have been followed up with considerable vigor by the proprietors. These proprietors are now a different and very superior class of men, to what they were fifty or sixty years ago. They have mostly been officers in the French army, and with it traversed the

greater part of Europe; better educated than many of the French, and more engaging in their manners than the Germans, they may be considered among the first gentlemen of the Continent. The Polish peasantry are naturally a much more lively and ingenious race than those of Russia, with whom they are generally compared; and they will gradually participate in the improvement of their masters.

SECT. VII. *Present State of the Agriculture of Russia.*

645. *The rural economy of the Russian empire* was first described by Professor Pallas in his travels to explore that country, made by order of the Empress Catherine. It has also been incidentally noticed by various travellers, as Tooke, Coxe, Clarke, and several French and German authors. From these and other works, and a personal residence which occupied nearly a year, in 1813 and 1814, we shall present a very concise statement of the agricultural circumstances of that semi-barbarous country.

646. *The territory of Russia which may be subjected to aration*, commences at the 43° and ends at the 65° of north latitude. Farther north, the summers are too short for ripening even barley, and the climate too severe for the growth of pasture or trees. It is a black waste, productive of little more than lichens, and supporting a few reindeer. The southern extremity of Asiatic Russia, on the other hand, admits the culture of Italy, and even the southern parts in Europe, that of the maize district of France.

647. *The climate of Russia* has been divided into four regions, the very cold, cold, temperate, and hot. The very cold extends from 60° to 78° of N. latitude, and includes Archangel. In many of its districts there is scarcely any summer; the spring has in general much frost, snow, and rain, and the winter is always severe. In this region there is no agriculture.

648. *The cold climate* extends from 55° to 60° N. latitude, and includes Casan, Moscow, Petersburg, and Riga; the summer is short, yet in many districts so warm, and the days so long, that agricultural crops usually come to perfect maturity, in a much shorter space of time than elsewhere. The winters are long and severe, even in the southern parts of the region. The ground round Moscow is generally covered with snow for six months in the year, and we have seen it covered to the depth of several inches in the first week of June.

649. *The moderate region* extends from 50° to 55° and includes Kioff, Saratoff, Wilna, and Smolensko. The Siberia part of this region being very mountainous, the winters are long and cold; but in the European part the winter is short and tolerably temperate, and the summer warm and agreeable. The snow, however, generally lies from one to three months, even at Kioff and Saratoff.

650. *The hot region* reaches from 43° to 50°, and includes the Taurida, Odessa, Astracan, and the greater part of Caucasus and the district of Kioff. Here the winter is short and the summer warm, hot and very dry. The atmosphere in all the different climates is in general salubrious, both during the intense colds of the north and the excessive heats of the southerly regions. The most remarkable circumstance is the shortness of the seasons of spring and autumn, even in the southern regions; while in the very cold and cold regions they can hardly be said to exist. About Moscow the termination of winter and the commencement of summer generally take place about the end of April. There the rivers, covered a yard in thickness with ice, break up at once and overflow their banks to a great extent; in a fortnight the snow has disappeared, the rotten-like blocks of ice dissolved, and the rivers are confined to their limits. A crackling from the bursting of buds is heard in the birch forests; in two days afterwards, they are in leaf; corn which was sown as soon as the lands were sufficiently dry to plough, is now sprung up, and wheat and rye luxuriant. Reaping commences in the government of Moscow in September, and finishes by the middle of October. Heavy rains and sleet then come on, and by the beginning of November the ground is covered with snow, which accumulates generally to two or three feet in thickness before the middle of January; and remains with little addition till it dissolves in the following April and May. The climate of Russia therefore, though severe, is not so uncertain as that of some other countries. From the middle of November till April it scarcely ever snows or rains; and if the cold is severe it is dry, enlivening, and at least foreseen and provided for. Its greatest evils are violent summer rains, boisterous winds, and continued autumnal fogs. Late frosts are more injurious than long droughts; though there are instances of such hot and dry summers, that fields of standing corn and forests take fire and fill whole provinces with smoke. (*Tooke's View of the Russian Empire.*)

651. *The surface of Russia* is almost every where flat, like that of Poland, with the exception of certain ridges of mountains which separate Siberia from the other provinces, and which also occur in Siberian Russia. In travelling from Riga, Petersburg, Wilna, or Brody, to Odessa, the traveller scarcely meets with an inequality sufficiently great to be termed a hill; but he will meet with a greater proportion of forests, steppes or immense plains of pasture, sandy wastes, marshy surfaces, and gulleys or temporary water courses, than in any other country of Europe.

652. *The soil of Russia* is almost every where a soft black mould of great depth, and generally on a sandy bottom. In some places it inclines to sand or gravel; in many it is peaty or boggy from not being drained; but only in Livonia and some parts of Lithuania was it inclined to clay, and no where to chalk. The most fertile provinces are those of Vladimir and Riazane east of Moscow, and the whole country of the Ukraine on the Black Sea, and of the Cossacks on the Don. In Vladimir thirty fold is often produced, and still more in Riazane. In many parts of the Ukraine no manure is used; the straw is burned; successive crops of wheat are taken from the same soil, and after a single ploughing each time, the stalks are so tall and thick that they resemble reeds, and the leaves are like those of Indian corn.

653. *Landed property in Russia* is almost every where in large tracts, and is either the property of the emperor, the religious or civil corporations, or the nobles. There are a few free natives who have purchased their liberty, and some foreigners, especially Germans, who have landed estates, but these are comparatively of no account. In the Ukraine, within the last thirty years, have been introduced on the government estates a number of foreigners from most countries of Europe, who may be considered as proprietors. These occupy the lands on leases of a hundred years or upwards, at little or no rent, on condition of peopling and cultivating them and residing there. In the country parts of Russia, there is no middle class between the nobles, including the priests, and the slaves. Estates are therefore either cultivated directly by the proprietors acting as their own stewards; indirectly by letting them to agents or factors, as in Poland and Ireland, or by dividing them in small portions among the peasantry. In general the proprietor is his own agent and farmer for a great part of his estate; and the rest he lets to his slaves at certain rates of labor, corn, personal services, and sometimes a little money. These slaves, it is to be observed, are as much his property as the soil; and in seasons of scarcity or in the event of any disaster, the lord is bound to provide them, and indeed deeply interested in doing so, in order at least to maintain the population, and if possible to obtain a surplus for sale, or for letting out to the towns. As in Poland the lands are every where unenclosed.

654. *The farmeries* attached to the houses of noblemen and the cottages of the paysants resemble those of Poland. They are almost every where constructed of timber; the stove and its chimney being the only part built of brick or of mud and stones. The noblemen generally reside on their estates, and their houses are surrounded by the village which contains their peasants. These villages (*fig. 80.*) are in general dull and miserable

80



assemblages of log-houses all of one size and shape, with a small wooden church. The mansions of the poorer kind are merely cottages on a larger scale, with two apartments; one used for all the purposes of the kitchen and other domestic offices, and the other for all the purposes of the family living rooms. The more wealthy nobles have wooden or brick houses stuccoed, or mudded and white washed. One nobleman in the neighborhood of Moscow has a British steward, who has drained, enclosed, and greatly improved his estate, and has built some farmeries (*fig. 81.*), which might be mistaken for those of another country.

81



655. *The agricultural products of Russia* may be known from its climates. The vegetables of the most northerly region are limited to lichens, some coarse grass, and some birch, abele, and wild pine forests. The animals are the reindeer, bear, fox, and other animals of the chase, or valued for their furs or skins. Some cows and sheep are also pastured in the northern parts of that region during the summer months.

656. *The farming crops of the more southern regions* are the same as in similar climates and countries. Winter and summer rye and oats are cultivated in every part of the empire, south of latitude 60°; winter wheat only in Russia as far as the Kama; summer wheat both in Russia and Siberia; barley and spelt plentifully in Russia. Pease, vetches, and beans are not cultivated in great quantities; but buckwheat is extensively grown, and there is a large variety, called the tartarian millet; panicum germanicum, and maize are grown in Taurida. Rice is cultivated in some parts of Taurida, and what is called manna (*Festuca fluitans*) grows wild in most places that are occasionally overflowed with water, particularly in the governments of Novogorod, Twer, Polotsk, and Smolensk. But the grain the most universally cultivated in Russia is rye, which is the bread corn of the country; next oats, which furnishes the spirit in common use, and then wheat and barley.

657. *The culture of herbage plants*, of grasses, clover, turnips, &c., is rare in Russia. Hay is made from the banks of rivers or lakes; and pasture obtained from the steppes, forests, grass lands in common, or arable lands at rest.

658. *The clothing and other economical plants in cultivation*, are flax, which is cultivated to a great extent on the Volga; hemp is indigenous, and is cultivated both for its fibre and its seed. From the latter an oil is expressed much used as food during the time of the fasts. Woad is abundantly grown, madder and cotton has been tried in Astracan and Taurida. Hops grow wild in abundance in some parts of Siberia, and are cultivated in some European districts. Tobacco is planted in great abundance, and the produce in the Ukraine is of excellent quality. The potatoe is not yet in general cultivation, but has been introduced in different districts. Water melons, cabbages, turnips, and a variety of garden vegetables, are cultivated in the Ukraine and Taurida. Asparagus is extensively cultivated in the government of Moscow for the Petersburg market, and also turnips, onions, and carrots. Mushrooms are found in great plenty in the steppes and forests. About thirty species are eaten by the peasants, exclusive of our garden mushroom, which is neglected. Their names and habitats are given by Dr. Lyall. (*History of Moscow*, 1824.) The common, and Siberian nettle, are found wild on the Ural mountains, and their fibres are prepared and wove into linen by the Baschkirs and Tatars. The rearing of silkworms has been tried in the Ukraine, and found to answer, as has the culture of the caper, and various other plants.

659. *Of fruits grown on a large scale*, or plentiful in a wild state in Russia, may be mentioned the raspberry, currant, strawberry, and bilberry. The hazle is so plentiful in Kazan, that an oil used as food is made from the nuts. Sugar, musk, and water melons thrive in the open air as far north as lat. 52°. Pears are wild almost every where, and cherries found in most forests. On the Oka and Volga are extensive orchards, principally of these fruits and apples. The apricot, almond, and peach succeed as standards in Taurida and Caucasus, and other southern districts. The quince is wild in forests on the Terek. Chestnuts are found singly in Taurida and districts adjacent. The walnut abounds in most southern districts. Figs and orange trees grow singly in Kitzliar and in Taurida, planted no doubt by the Tatars before they were driven out of that country. Lemons, oranges, and olives, according to Pallas, would bear the winter in Taurida; and have been tried by Stevens, the director of a government nursery at Nikitka, in that country. The vine is cultivated in the governments of Caucasus, Taurida, Ekatorinoslaf, and other places, and it is calculated that nearly one fourth part of the empire is fit for the culture of this fruit for wine. An account of the products of the Crimea is given by Mary Holderness, (*Notes, &c.*, 1821.) from which it appears that all the fruits of France may be grown in the open air there, and that many of our culinary vegetables are found in a wild state. The Tatar inhabitants, who were driven out by the ambitious wars of Catherine, had formed gardens and orchards round their villages which still exist, and present a singular combination of beauty, luxuriance, and ruin. The gardens of the village of Karagoss form a wilderness of upwards of three hundred and sixty English acres, full of scenes of the greatest beauty, and through which, she says, it requires a little experience to be able to find one's way. (*Notes, &c.*, 125—135.)

660. *The live stock of the Russian farmer* consists of the reindeer, horse, ox, ass, mule, and camel as beasts of labor; the ox, sheep, and swine, and in some places the goat and rabbit, as beasts of clothing and nourishment. Poultry are common, and housed with the family to promote early laying, in order to have eggs by Easter, a great object with a view to certain ceremonies in the Russian religion. Bees are much attended to in the Ural, in some parts of Lithuania, and in the southern provinces. The Russian working horses are remarkably strong and hardy; rather small, with large heads, long flabby ears, not handsome, but not without spirit. The best saddle horses are those of the

Cossacks and Tatars in the Crimea. The horned cattle of the native breeds are small and brisk; the cows give but little milk, which is poor and thin. A Dutch breed was introduced by Peter the Great, near Archangel, and do not degenerate. Oxen are much less used than horses as beasts of labor. The original Russian sheep is distinguished by a short tail about seven inches in length. The Merinos and other breeds from Germany have been introduced in a few places and promise success. The great graziers and breeders of horses, cattle, and sheep in Russia, are the Cossacks of the Don, the Kalmucks, and other Nomadic tribes. These supply the greater part of the towns both of Russia and Poland with butcher's meat; and it is their hides and tallow that form so material an article of export. In the northern districts of Russia and Siberia, the chase is pursued as an occupation for a livelihood or gain. The chief object is to entrap by dogs and snares those animals whose skins are used as furs, and especially the sable. Next to the latter animal, the grey squirrel is the most valuable; but the skins of foxes, martins, fish, otters, bears, wolves, lynxes, gluttons, ferrets, polecats, and a variety of others, are taken. The hunters pay a rent or tribute to government in sable skins, or in other furs regulated by the value of those.

661. *The forests of Russia* are least abundant in the southern districts; but the cold region may, like Poland, be described as one entire forest, with extensive glades. Forests of pine leaved trees (or needle leaved trees, as the German expression is,) are chiefly indigenous in the very cold, and cold regions. These include the spruce fir, the wild, and black pine, and the Siberian cedar or stone pine (*Pinus cembra*). The larch grows on most of the Siberian mountains. Among the leafy trees, the birch is the most common, next the trembling poplar, willow, lime, and ash. The oak is not indigenous in Siberia; the beech, elm, maple, and poplar, are found chiefly in the southern districts. Timber of construction, fuel, charcoal, bark, potashes, barilla, rosin, tar, pitch, &c., are obtained from these forests, which can hardly be said to have any sort of culture applied to them.

662. *The implements and operations of Russian husbandry* are the most simple and artless that can well be imagined. Pallas has given figures of ploughs and other articles; the former mere crooked sticks pointed, and drawn by horses, attached by ropes of bark or straw. Speaking of the operations, he says, "the cultivator sows his oats, his rye, or his millet, in wastes which have never been dunned; he throws down the seed as if he meant it for the birds to pick up; he then takes a plough and scratches the earth, and a second horse following with a harrow terminates the work; the bounty of nature supplies the want of skill, and an abundant crop is produced." This applies to the greater part of ancient Russia and Siberia; but in Livonia and other Baltic provinces, and also in some parts of the Polish provinces of the Ukraine, the culture is performed in a superior manner with implements equal to the best of those used in Germany. In the Crimea, Mary Holderness informs us that the men dig in a sitting posture, and also that smiths work in the same manner, both smoking all the time; they never grease the axles of their carts, which, in consequence, make a disagreeable creaking noise, heard at a great distance: when asked the reason, they answer, "we are not thieves and are therefore not ashamed that the world should hear of our movements." 82

The most improved form of their carts (*fig. 82.*) in use round Petersburg, is evidently copied from those of the Dutch, and was probably introduced by Peter the Great. In the Ukraine they thresh out their corn by dragging boards studded with flints over it, and preserve it in pits in dry soil. In the northern provinces it is often dried on roofed frames of different sorts (*fig. 83.*) as in Sweden; and about Riga and Mittau it is even kiln dried in the sheaf, before it can be stacked or threshed. The manner of performing the operation of kiln drying in the sheaf, as it may sometimes be applicable in North Britain or Ireland in very late and wet seasons, we shall afterwards describe. (Part III. Book V. Ch. II.)

663. *In no part of Europe are the field operations performed with such facility as in Russia*, not only from the light nature of the soil, but from the severity and long continuance of the winters, which both pulverizes the surface and destroys weeds. The same reasons prevent grass lands, or lands neglected or left to rest, from ever acquiring a close sward, or tough rooty surface, so that even these are broken up with a very rude plough and very little labor. In short, there is no country in Europe where corn crops may be raised at so little expense of labor as in Russia, and as no more than one corn crop can be got in the year in almost any country, so Russia may be said to be, and actually is, even with her imperfect cultivation, better able to raise im-

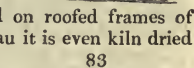

mense quantities of corn than any part of the world, excepting perhaps similar parts of North America.

664. *The improvement of Russian agriculture* was commenced by Peter the Great, and continued by Catherine, and the present emperor. The peasants, on many of the government estates, were made free; some of these estates were let or sold to freemen, and foreign agriculturists encouraged to settle on them. Rewards and premiums were given, and professorships of rural economy established in different parts of the empire. Some of the principal nobles have also made great efforts for the improvement of agriculture. Count Romansow, about the end of the last century, procured a British farmer (Rogers), and established him on his estate near Moscow, where he has introduced the improved Scotch husbandry, drained extensively, established a dairy, and introduced the potatoe there, and on other estates belonging to his master. Others have made similar efforts, and several British farm bailiffs are now settled in Russia. The foreigners, merchants in Petersburg, or Riga, or in the employ of government, have also contributed to the improvement of agriculture. Many of these intending to establish their families in Russia, purchase estates, and some receive presents in land from the emperor. On these they in general introduce the culture of their native country, which, if only in the superiority of the live stock and implements, is certain of being better than that of the natives. In short, from these circumstances, and from the comparatively rational views of the present emperor, there can be no doubt of the rapid encrease of agriculture and population in Russia.

#### SECT. VIII. *Present State of the Agriculture of Sweden and Norway.*

665. *Sweden and Norway are not agricultural countries*; but still great attention has been paid to perfect such culture as they admit of, both by the government and individuals. From the time of Charles XI., in the end of the seventeenth century, various laws for the encouragement of agriculture have been passed, professorships founded, rewards distributed, and the state of the kingdom, in respect to its agricultural resources, examined by Linnæus and other eminent men. Norway, till lately under the dominion of Denmark, is chiefly a pastoral country; but its live stock and arable culture have been much improved during the end of the last, and beginning of the present century, by the exertions of the Patriotic Society established in that country, which gives premiums for the best improvements and instructions in every part of farming. Our notice of the rural economy of these countries are drawn from Clarke, Thomson, James, and our own memoranda, made there in 1813.

666. *The climate of Sweden and Norway* is similar to that of the cold and very cold regions of Russia, but rather milder in its southern districts, on account of the numerous inlets of the sea. The lands on the sea-coast of Norway are not on this account so cold as their latitude would lead us to expect; still the winters are long, cold, and dreary; and the summers short and hot, owing to the length of the day and the reflection of the mountains. So great is the difference of temperature, that at Sideborg, in the latitude of Upsal, in June or July, it is frequently eighty or eighty-eight degrees, and in January at forty or fifty below the freezing point. The transition from sterility to luxuriant vegetation is in this, as it is in similar climates, sudden and rapid. In the climate of Upsal, the snow disappears in the open fields from the 6th to the 10th of May; barley is sown from the 13th to the 15th of that month, and reaped about the middle of August. In some parts of Norway corn is sown and cut within the short period of six or seven weeks. According to a statement published in the *Aman. Acad.* vol. iv., a Lapland summer, including also what, in other countries, is called spring and autumn, consists of fifty-six days, as follows:—

June 23, snow melts.

July 1, snow gone.

— 9, fields quite green.

— 17, plants at full growth.

— 25, plants in full blow.

Aug. 2, fruits ripe.

— 10, plants shed their seeds.

— 18, snow.

From this time to June 23, the ground is every where covered with snow, and the waters with ice.

In such a climate, no department of agriculture can be expected to flourish. The culture of corn is only prevalent in two districts, East Gothland, and the eastern shores of the Gulph of Bothnia, now belonging to Russia.

667. *The surface of Sweden* every body knows to be exceedingly rocky and hilly, and to abound in fir and pine forests, and in narrow green vallies, often containing lakes or streams. "Sweden," Dr. Clarke observes, "is a hilly, but not a mountainous country, excepting in its boundary from the Norwegian provinces. It has been remarked, that in all countries, the abutment of the broken strata, which constitute the earth's surface every where, causes a gradual elevation to take place towards the north-west; hence, in all countries, the more level districts will be found upon the eastern, and the mountainous or metalliferous region upon the western side; either placed as a natural boundary against the territory occurring next in succession; or terminating in rocks of primary



formation opposed as cliffs towards the sea." (*Clarke's Scandinavia.*) This is precisely the case with Sweden: the south-eastern provinces are level and cultivated; a ridge of mountains on the west separate it from Norway, and the intermediate space, from Gothenberg to Tornea, may be considered as one continued forest, varied by hills, rocks, lakes, streams, glades of pasture, and spots of corn culture. Norway may be considered as a continuation of the central country of Sweden, terminated by cliffs opposed to the ocean. "The tops and sloping sides of the mountains," Dr. Clarke observes, "are covered with a verdure; farms are stationed on a series of tabular eminences, and grazing around them the herds of cattle all the way from the top to the bottom, and sometimes in places so steep, that we wonder how they could find a footing. In some places the elevation of these farms is so extraordinary, that the houses and flocks appear above the clouds, and bordering on perpetual snow, and the actual sight of them is hardly to be credited. Every hanging-meadow is pastured by cows and goats; the latter often brousing upon jutties, so fearfully placed, that their destruction seems to be inevitable; below is seen the village-church with its spire, the whole built of plank (*fig. 84.*); the cheerful bleatings of the sheep, mingled at intervals with the deep tones of the cow-herds' lures (*fig. 85.*), resounding from the woods. The lure is a long trumpet made of splinters of wood, bound together by withy.

84



The lure is a long trumpet made of splinters

85



668. *Of Finland*, which we have included with Sweden and Norway, a considerable part is under corn culture; the forests cleared, the lands enclosed, and population increased. The whole country appears decked with farm-houses, and village churches, rising to the view or falling from it, over an undulating district, amidst woods and water, and rocks, and large loose masses of granite: it may be called Norway in miniature. Farther up the country, towards the north, there are scenes which were described to Dr. Clarke as unrivalled in the world. Every charm which the effect of cultivation can give to the aspect of a region where Nature's wildest features—headlong cataracts, lakes, majestic rivers, and forests — are combined, may there be seen." (*Scandinavia*, sect. ii. p. 459.)

669. *The soil of the vallies is*, in general, good friable loam, but so mixed with stones as to render it very troublesome to plough or harrow; and in many places so much so, that where the vallies are cultivated it is chiefly with the spade. The only exception to these remarks is a considerable tract of comparatively even surface in South and East Gothland, where the soil inclines to clay and is well cultivated, and as prolific in corn crops as any in Europe.

670. *The landed property of Sweden is generally in estates of a moderate size; in many cases their extent in acres is unknown; their value being estimated by the number of stock grazed in summer. The proprietors almost constantly farm their own estates, or let them out at fixed rents, in money or grain, to cottagers or farmers. The largest arable farms not occupied by the proprietors are in Gothland; but few of these exceed two hundred acres. The farm-buildings and cottages are there almost always built of timber and thatched, on account of the warmth of these materials, though stone is abundant in most places. There are a few small enclosures near the farm-yard; but to enclose generally could be of no use in a country where the snow, during six or eight months of the year, renders them nugatory both as shelters and fences. The fence in universal use is made of splinters of deal, set up in a sloping position, and fastened by withys to upright poles (*fig. 86.*) This is the only fence used in Sweden, Norway, Lapland, and Finland; and it is very common in Poland, Russia, and the northern parts of Germany.*

86



671. *The Swedish cottages* are built of logs, like those of Poland (fig. 87.), but they are roofed in a different manner. Above the usual covering of boards is laid birch bark, in the manner of tiles, and on that a layer of turf, so thick that the grass grows as vigorously as on a natural meadow. The walls are often painted red: they are very small, and generally very close and dirty within, at least in winter. There are various exceptions, however, as to cleanliness, especially among the post-masters, who are all farmers. The post-house at Yfre, north of Stockholm, was found by Dr. Clarke and his party so "neat and comfortable, and every thing belonging to it in such order," that they resolved to dine there. "The women were spinning wool, weaving, heating the oven, and teaching children to read, all at the same time. The dairy was so clean and cool, that we preferred having our dinner there, rather than in the parlor. For our fare they readily set before us a service consisting of bacon, eggs, cream, curd, and milk, sugar, bread, butter, &c.; and our bill of fare for the whole amounted only to twenty pence; receiving which they were very thankful. Cleanliness in this farmer's family was quite as conspicuous as in any part of Switzerland. The tables, chairs, and the tubs in which they kept their provisions, were as white as washing could make them; and the most extraordinary industry had been exerted in clearing the land, and in rendering it productive. They were at this time employed in removing rocks, and in burning them for lævigation, to lay the earth again upon the soil." (*Scandinavia*, sect. i. p. 179.)



672. *The cottages in Norway* are formed as in Sweden, covered with birch bark, and turf. On some of the roofs, after the hay was taken, Dr. Clarke found lambs pasturing; and on one house he found an excellent crop of turnips. The galleries about their houses remind the traveller of Switzerland.

673. *The cottages of the Laplanders* are round huts of the rudest description (fig. 88.)

674. *The agricultural produce of Sweden* are the common corns. Wheat and rye are chiefly grown in South and East Gothland; oats are the bread-corn of the country; and big or Scotch barley is the chief corn of Lapland and the north of Norway. The bean and pea are grown in Gothland, and the potatoe, flax, and enough of tobacco for



home consumption, by every farmer and cottager. Only a few districts grow sufficient corn for their own consumption, and annual importations are regular.

675. *The Lichen rangiferinus*, or reindeer moss, (fig. 89.), is not only used by the reindeer, but also as fodder for cows and other horned cattle. It adds a superior richness to the milk and butter. It is sometimes eaten by the inhabitants; and Dr. Clarke having tasted it, found it crisp and agreeable.

676. *The Lichen roccella*, which abounds near Gottenburg and other parts of Sweden, was in considerable demand in the early part of last war as a scarlet dye.

677. *The Lycopodium complanatum* (fig. 90.) is employed in dyeing their woollen. Even the leaves, as they fall from the trees, are carefully raked together and preserved, to increase the stock of fodder. (*Scandinavia*, chap. xviii.)

678. *Tar* in Sweden is chiefly extracted from the roots of the spruce fir, and the more marshy

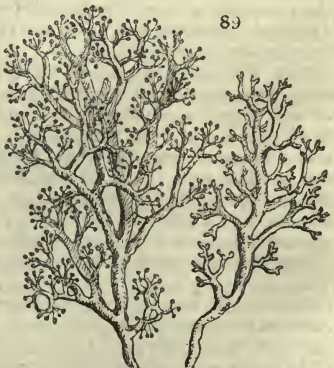

the forest the more the roots are said to yield. Roots or billets of any kind are packed close in a kiln, made like our lime-kilns in the face of a bank. They are covered with turf and earth, as in burning charcoal; at the bottom of the kiln is an iron pan into which the tar runs during the smothered combustion of the wood. A spout from the iron pan conveys the tar at once into the barrels, in which it arrives in this country.

679. *The native trees and plants* afford important products for the farmer. "The industry of the Norwegians," Dr. Clarke observes, "induces them to appropriate almost every thing to some useful purpose. Their *summum bonum* seems to consist in the produce of the fir (*i. e.* the wild pine, not the spruce fir). This tree affords materials for building their houses, churches, and bridges; for every article of their household furniture; for constructing sledges, carts, and boats; besides fuel for their hearths. With its leaves (here the spruce fir is alluded to) they strew their floors, and afterwards burn them and collect the ashes for manure. The birch affords in its leaves and tender twigs a grateful fodder for their cattle, and bark for covering their houses. The bark of the elm in powder, is boiled up with other food, to fatten hogs; sometimes, but rarely, it is mixed in the composition of their bread. The flowers of the hæg-ber (*Cornus mascula*) flavor their distilled spirits. The moss, as a substitute for mortar, is used in caulking the interstices between their under walls. The turf covers their roofs.



680. *The berries of the Cloud-berry (Rubus chamaemorus)* (fig. 91.) are used in Lapland and the north of Sweden and Norway like the strawberry, and are esteemed as wholesome as they are agreeable.

91



Dr. Clarke was cured of a bilious fever chiefly from eating freely of this fruit. They are used as a sauce to meat, and put into soup even, in Stockholm.

681. *The live-stock* of the Swedish farmer consists chiefly of cows. These are treated in the same manner as in Switzerland. About the middle of May they are turned into meadows; towards the middle of June driven to the heights, or to the forests, where they continue till autumn. They are usually attended by a woman, who

inhabits a small hut, milks them twice a-day, and makes butter and cheese on the spot. On their return, the cattle are again pastured in the meadows, until the snow sets in about the middle of October, when they are removed to the cow-houses, and fed during winter with four-fifths of straw and one of hay. In some places, portions of salted fish are given with the straw. The horses are the chief animals of labor; they are a small, hardy, spirited race, fed with hay and oat-straw the greater part of the year, and not littered, which is thought to preserve them from diseases. Sheep are not numerous, requiring to be kept under cover so great a portion of the year. Pigs and poultry are common.

682. *The implements and operations* of Swedish agriculture are simple, and in many places of an improved description. The swing plough, with an iron mould-board, is general throughout Gothland, and is drawn by two horses. The plough of Österothnia (fig. 92.) is drawn by a single horse, and sometimes by a peasant, and called to Dr. Clarke's mind "the old Samnite plough, as it is still used in the neighborhood of Beneventum, in Italy; where a peasant, by means of a cord passed over his shoulder, draws the plough, which his companion guides. It only differs from the most ancient plough of Egypt, as we see it represented upon images of Osiris (fig. 93.), in having a double instead of a single coulter." (Scandinavia, ch. xiii.)

92

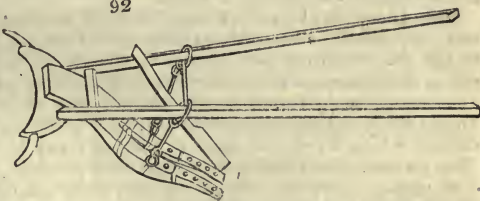

93

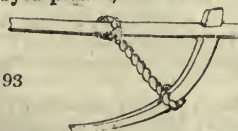

They have a very convenient cradle-scythe for mowing oats and barley, which we shall afterwards describe, a smaller scythe, not unlike that of Hainault, for cutting grass and clovers; and among other planting instruments, a frame of dibbers (fig. 94.) for planting beans and pease at equal distances.

683. *Farming operations* are, in general, as neatly performed as any where in Britain. The humidity of the climate has given

94

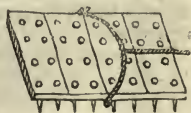

rise to various tedious but ingenious processes for making hay and drying corn. The latter often remains in the fields in shocks, or in small ricks, after the ground is covered with snow, till the clear frosts set in, when it becomes dry, and may be taken home. Besides the common mode of placing the sheaves astride with the ears downwards on horizontal fir poles (*fig. 95.*), there are a variety of others. In some places young fir trees, with the stumps of the branches left on, are fixed in the ground, and the sheaves hung on them, like flowers on a maypole, the topmost sheaf serving as a cap or finish to all the rest. Sometimes covered rails or racks are resorted to (*fig. 83.*): at other times skeleton roofs or racks are formed, and the sheaves distributed over them (*fig. 96.*) Often in Norway the corn is obliged to be cut green, from the sudden arrival of winter. Dr. Clarke found it in this state in October; and near Christiania it was suspended on poles and racks to dry, above fields covered with ice and snow. Corn is threshed in the north of Sweden by passing over it a threshing-



95

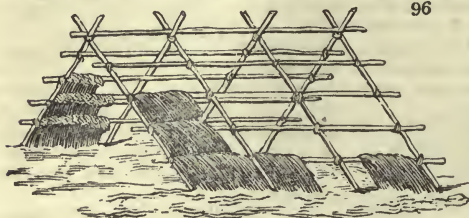

96

carriage, which is sometimes made of cast-iron, and has twenty wheels, and sometimes more. The sheaves are spread on a floor of boards, and a week's labor of one cart, horse, and man, will not thresh more than a ton of corn, the crop being always cut before it is fully ripened, and then dried on racks. The hay is sometimes dried in the same manner.

After all, they are in some seasons obliged to dry both, especially the corn, in sheds or barns heated by stoves, as in Russia (662.). In mowing hay in Lapland the scythe, the blade of which is not larger than a sickle, is swung by the mower to the right and left, turning it in his hands with great dexterity.

684. *The forests of Sweden are chiefly of the wild pine and spruce fir; the latter supplies the spars, and the former the masts and building timber so extensively exported. The roads in Norway, as in some parts of Russia, are formed of young trees laid across and covered with earth, or left bare. Turpentine is extracted: the outer bark of the beech is used for covering houses, and the inner for tanning. The birch is also tapped for wine; and the spray of this tree, the elm, the alder, and willow, are dried with their leaves on in summer, faggotted and stacked for winter fodder. The young wood and inner bark of the pine, fir, and elm, are powdered and mixed with meal for feeding swine. It is remarkable, that neither the inhabitants of Russia nor of Sweden have learned to eat the seeds of the pine and fir tribe, which are both wholesome and agreeable, and esteemed a delicacy in Italy.*

685. *The chase is pursued as a profitable occupation in the northern parts of Sweden, and for the same animals as in Russia.*

686. If any one, says Dr. Clarke, wishes to see *what English farmers once were*, and how they fared, he should visit Norway. Immense families, all sitting down together at one table, from the highest to the lowest. If but a bit of butter be called for in one of these houses, a mass is brought forth weighing six or eight pounds; and so highly ornamented, being turned out of moulds, with the shape of cathedrals, set off with Gothic spires and various other devices, that, according to the language of our English farmers' wives, we should deem it "almost a pity to cut it." (*Scandinavia*, ch. xvi.) They do not live in villages, as in most other countries, but every one on his farm, however small. They have in consequence little intercourse with strangers, excepting during winter, when they attend fairs at immense distances for the purpose of disposing of produce, and purchasing articles of dress. "What would be thought in England," Dr. Clarke asks, "of a laboring peasant, or the occupier of a small farm, making a journey of nearly 700 miles to a fair for the articles of their home consumption?" Yet he found Finns at the fair at Abo, who had come from Torneo, a distance of 679 miles, for this purpose.

687. *With respect to improvement the agriculture of Sweden is perhaps susceptible of less than that of any of the countries we have hitherto examined; but what it wants will be duly and steadily applied, by the intelligence and industry of all ranks in that country. It must not be forgotten, however, that it is a country of forests and mines, and not of agriculture.*

SECT. IX. *Present State of the Agriculture of Spain and Portugal.*

688. *Spain, when a Roman province*, was undoubtedly as far advanced in agriculture as any part of the empire. It was overrun by the Vandals and Visigoths in the beginning of the fifth century, under whom it continued till conquered by the Moors in the beginning of the eighth century. The Moors continued the chief possessors of Spain until the middle of the thirteenth century. They are said, during this period, to have materially improved agriculture; to have introduced various new plants from Africa, and also bucket-wheels for irrigation. Professor Thouin mentions an ancient work by Ebn-al-Awam of Seville, of which a translation into Spanish was made by Banquieri of Madrid, in 1802, which contains some curious particulars of the culture of the Moors in Spain. The Moors and Arabs were always celebrated for their knowledge of plants; and, according to Harte, one fourth of the names of the useful plants of Spain are of Arabian extraction.

689. *Agriculture formed the principal and most honorable occupation among the Moors*, and more especially in Granada. So great was their attention to manure, that it was preserved in pits, walled round with rammed earth to retain moisture: irrigation was employed in every practicable situation. The Moorish or Mahomedan religion forbade them to sell their superfluous corn to the surrounding nations; but in years of plenty it was deposited in the caverns of rocks, and in other excavations, some of which, as Jacob informs us (*Travels*, let. xiii.), are still to be seen on the hills of Granada. These excavations were lined with straw, and are said (erroneously, we believe,) to have preserved the corn for such a length of time that when a child was born a cavern was filled with corn, which was destined to be his portion when arrived at maturity. The Moors were particularly attentive to the culture of fruits, of which they introduced all the best kinds now found in Spain, besides the sugar and cotton. Though wine was forbidden, vines were cultivated to a great extent; for forbidden pleasures form a main source of enjoyment in every country. An Arabian author, who wrote on agriculture about the year 1140, and who quotes another author of his nation, who wrote in 1073, gives the following directions for the cultivation of the sugar-cane:—

690. *The canes* “should be planted in the month of March, in a plain, sheltered from the east wind, and near to water; they should be well manured with cow-dung, and watered every fourth day, till the shoots are one palm in height, when they should be dug round, manured with the dung of sheep, and watered every night and day till the month of October. In January, when the canes are ripe, they should be cut into short pieces and crushed in the mill. The juice should be boiled in iron cauldrons, and left to cool till it becomes clarified; it should then be boiled again, till the fourth part only remain, when it should be put into vases of clay, of a conical form, and placed in the shade to thicken; afterwards the sugar must be drawn from the canes and left to cool. The canes, after the juice is expressed, are preserved for the horses, who eat them greedily, and become fat by feeding on them.” (*Ebn-al-Awam*, by Banquieri, Madrid, 1801, fol.) From the above extract it is evident sugar has been cultivated in Spain upwards of 700 years, and probably two or three centuries before.

691. *About the end of the fifteenth century* the Moors were driven out of Spain, and the kingdom united under one monarchy. Under Charles V., in the first half of the sixteenth century, South America was discovered; and the prospect of making fortunes by working the mines of that country is said to have depressed the agriculture of Spain to a degree that it has never been able to surmount. (*Heylin's Cosmographia*, Lond. 1657.) Albyterio, a Spanish author of the seventeenth century, observes, “that the people who sailed to America in order to return laden with wealth, would have done their country much better service to have staid at home and guided the plough; for more persons were employed in opening mines and bringing home money, than the money in effect proved worth.” This author thinking with Montesquieu, that those riches were of a bad kind which depend on accidental circumstances, and not on industry and application.

692. *The earliest Spanish work on agriculture* appeared in 1569, by Herrera: it is a treatise in many books, and, like other works of its age, is made up of extracts from the Roman authors.

693. *The agriculture of Spain in the middle of the eighteenth century* was in a very neglected state. According to Harte, “the inhabitants of Spain were then too lazy and proud to work. Such pride and indolence are death to agriculture in every country. Want of good roads and navigable rivers (or, to speak more properly, the want of making rivers navigable), have helped to ruin the Spanish husbandry. To which we may add another discouraging circumstance, namely, ‘that the sale of an estate vacates the lease: *Venta deschaze renta*.’ Nor can corn be transported from one province to another. The Spaniards plant no timber, and make few or no enclosures. With abundance of excellent cows, they are strangers to butter, and deal so little in cows’ milk, that, at Madrid, those who drink milk with their chocolate, can only purchase goats’ milk. What would Columella say, (having written so largely on the Andalusian dairies,) if it were possible for him to revisit this country? For certain it is, that every branch of

rural economics, in the time of him and his uncle, was carried to as high perfection in Spain as in any part of the Roman empire. Though they have no idea of destroying weeds, and scratch the ground instead of ploughing it, yet nature has been so bountiful to them, that they raise the brightest and firmest wheat of any in Christendom." (*Essays, &c. i.*)

694. *A general spirit for improvement* seems to have sprung up in Spain with the nineteenth century, though checked for a while by the wars against Buonaparte; subsequently retarded by internal discords; and again by the cruel interference of the French in 1823. In the midst of these troubles, economical societies have been established at Madrid, Valencia, and Saragossa. That of the latter place is connected with a charitable bank in favor of distressed farmers. Money is advanced to defray the expenses of harvest, and two years allowed for returning it. It commenced its operations in June 1801, and then distributed 458*l.* 2*s.* to one hundred and ten husbandmen. In the August following it had furnished sixty-two horses to as many indigent farmers. The Patriotic Society of Madrid has distinguished itself by a memoir on the advancement of agriculture, and on Agrarian laws, addressed to the supreme council of Castile in 1812. It was drawn up by a distinguished member, Don G. M. Jovellanos, who recommends the enclosure of lands, the enactment of laws favorable to agriculturists, the prevention of the accumulation of landed property in mortmain tenure; exposes the noxious state of the estates of the clergy, of various taxes on agricultural productions, and of restrictions on trade and the export of corn. His whole work breathes the most liberal, enlightened, and benevolent spirit, and was in consequence so offensive to the clergy, that they procured his condemnation by the inquisition. (*Ed. Rev. Jacob's Travels, &c.*)

695. *The climate of Spain* is considered by many as superior to that of any country in Europe. It is every where dry, and though the heat in some provinces is very great in the day, it is tempered during the night by breezes from the sea, or from the ridges of high mountains which intersect the country in various directions. In some provinces the heat has been considered insalubrious, but this is owing to the undrained marshes, from which malignant effluvia are exhaled. The mean temperature of the elevated plains of Spain is 59°; that of the coasts from 41° to 36° of latitude, is between 63½° and 68°; and is therefore suitable for the sugar-cane, coffee, banana, and all plants of the West India agriculture, not even excepting the pine-apple. The latter is cultivated in the open air in some gardens in Valencia and at Malaga.

696. *The surface of Spain* is more irregular and varied by mountains than that either of France or Germany. These intersect the country at various distances from east to west, and are separated by valleys or plains. The strata of the mountains is chiefly granitic or calcareous; but many are argillaceous, some silicious, and Montserrat, near Cardova, is a mass of rock salt. A remarkable feature in the surface of Spain, is the height of some of its plains above the level of the sea. According to Humboldt, the plain of Madrid is the highest plain in Europe that occupies any extent of country. It is 309¾ fathoms above the level of the ocean, which is fifteen times higher than Paris. This circumstance both affects the climate of that part of the country, and its susceptibility of being improved by canal or river navigation. The rivers and streams of Spain are numerous, and the marshes not very common. Forests, or rather forest-wastes, downs, and Merino sheep-walks, are numerous, and, with other uncultivated tracts and heaths, are said to amount to two-thirds of the surface of the country. Some tracts are well cultivated in the vine districts, as about Malaga; and others in the corn countries, as about Oviedo. The resemblance between the Asturias and many parts of England is very striking. The same is the aspect of the country, as to verdure, inclosures, live hedges, hedge-rows, and woods; the same mixture of woodlands, arable and rich pasture, the same kind of trees, and crops, and fruit, and cattle. Both suffer by humidity in winter, yet, from the same source, find an ample recompence in summer; and both enjoy a temperate climate, yet, with this difference, that as to humidity and heat, the scale preponderates on the side of the Asturias. In sheltered spots, and not far distant from the sea, they have olives, vines, and oranges. (*Townsend's Spain, i. 318.*)

697. *The soil of Spain* is in general light, and either sandy or calcareous, reposing on beds of gypsum or granite. The poorest soil is a ferruginous sand on sandstone rock, only to be rendered of any value by irrigation. The marshes, and also the best meadow soils, are along the rivers.

698. *The landed property of Spain* till the late revolution was similarly circumstanced to that of France and Germany; that is, in the possession of the crown, great nobles, and religious and civil corporations. Tithes were more rigidly exacted by the clergy of Spain than by those of any other country of Europe, (*Jacob's Travels, 99.*), and a composition in lieu of tithes was unknown in most provinces. Great part of the lands of the religious corporations are now sold, and a new class of proprietors are originating, as in France. Some of these estates are of immense extent. The monks of

Saint Hieronymo told Jacob that they could travel twenty-four miles from Seville on their own property, which is rich in corn, oil, and wine. Such was the corruption of this convent, that notwithstanding all their riches, they were deeply in debt. Lands were, and are cultivated in great part by their proprietors; and even the monasteries held large tracts in hand before their dissolution. What is farmed, is let out in small portions of arable land, with large tracts of pasture or waste, and a fixed rent is generally paid, chiefly in kind. The lands are open every where, excepting immediately round towns and villages. Many persons in Granada are so remote from the farmeries; that during harvest the farmers and their laborers live in tents on the spot both when they are sowing the corn, and cutting and threshing it. The hedges about Cadiz are formed of the soccotrine aloe and prickly pear; the latter producing at the same time an agreeable fruit, and supporting the cochineal insect. Farm-houses and cottages are generally built of stone or brick, and often of rammed earth, and are covered with tiles or thatch.

699. *A bad feature in the policy of the ancient regime*, considered highly injurious to agriculture and the improvement of landed property, deserves to be mentioned. This is, the right which the corporation of the mesta or Merino proprietors possess, to drive their sheep over all the estates which lie in their route, from their summer pasture in the north to their winter pasture in the south of the kingdom. This must of course prevent or retard enclosing and aration. In Catalonia, as in many parts of the continent, there exists what is called the emfiteutic contract. By the *emfiteutic contract* the great proprietor, inheriting more land than he can cultivate to profit, has power to grant any given quantity for a term of years; either absolute or conditional; either for lives, or in perpetuity; always reserving a quit rent, like our copyhold, with a relief on every succession, a fine on the alienation of the land, and other seigniorial rights dependant on the custom of the district; such as tithes, mills, public-houses, the obligation to plough his land, to furnish him with teams, and to pay hearth-money, with other contributions, by way of commutation for ancient stipulated services. One species of grant for uncultivated land, to be planted with vines, admitted formerly of much dispute. The tenant holding his land as long as the first planted vines should continue to bear fruit; in order to prolong this term, he was accustomed to train layers from the original stocks, and by metaphysical distinctions between identity and diversity, to plead, that the first planted vines were not exhausted, claiming thus the inheritance in perpetuity. After various litigations and inconsistent decisions of the judges, it was finally determined, that this species of grant should convey a right to the possession for fifty years, unless the plantation itself should previously fail.

700. *The agricultural products of Spain* include all those of the rest of Europe, and most of those of the West Indies; besides all the grains, for the production of which some provinces are more celebrated than others, and most of them are known to produce the best wheat in Europe. Flax hemp, esparto, palmetto (*Chamerops humilis*), madder, saffron, aloe, cork-tree (*Quercus suber*). The kermes grana, a species of coccus, whose body, in the grub state, yields a beautiful scarlet color, and which forms its nidus on the shrub quercus coccifera. Soda from the salicornea and other plants of the salt marshes; honey from the forests; dates (*Phoenix dactylifera*), coffee, almonds, filberds, figs, olives, grapes, peaches, prickly pears, carob beans, (the locust trees of scripture, *Ceratonia siliqua*), oranges, lemons, pomegranates, and other fruits.

701. *The esparto rush* (*Stipa tenacissimo*, L.) grows wild on the plain, and is made into a variety of articles for common use. It is employed for making ropes and cables, and is particularly calculated for the latter purpose, as it swims on the water, and the cables formed of it, are consequently not so liable to rub against the rocks as those which are made of hemp. It is also woven into floorcloths and carpets, and made into baskets or panniers, for carrying produce to market, or manure to the fields. In Pliny's time this plant was used by the poor for beds, by the shepherds for garments, and by the fishermen for nets; but is it now superseded for these and various other ends by the hemp and flax.

702. *The pita, or aloe*, (*Aloe soccotrina*, fig. 97 a.) is an important plant in the husbandry of Spain. It grows by the leaf, which it is only necessary to slip off and lay on the ground with the broad end inserted a little way in the soil: it makes excellent fences; and the fibres, separated from the mucilage, have been twisted into ropes, and woven into cloth.



Bowles, the best Spanish writer on natural history, says, the mucilage might easily be made into brandy. The same plant is used as the boundary fence for villages in the East Indies, and is found a powerful obstacle to cavalry.

703. *The hina*, or Indian fig, (*Cactus opuntia*, fig. 97 b.) is cultivated in the plains of Seville for its fruit, and also for raising the cochineal insect. It is either grown on rocky places or as hedges.

704. *The palmetto*, or fan palm (*Chamærops humilis*), is grown near Seville. From the foot-stalks of the leaves, brushes and brooms of various kinds are formed both for home use and exportation.

705. *The potatoe* is grown, but not in large quantities; nor so good as in England. The Irish merchants of the seaports import them for themselves and friends. The batatas, or sweet potatoe (*Convolvulus batatas*), turnips, carrots, cabbages, carrots, broccoli, celery, onions, garlic, melons, pumpkins, cucumbers, &c., are grown in large quantities.

706. *Though the olive* is grown to greater perfection in Spain than in Italy, yet the oil is the worst in Europe; because the growers are thirled, that is, obliged to grind their fruit at certain mills. To such mills (fig. 98.), all the olives of a district are obliged to be carried, and as they cannot all be ground alone, they are put into heaps to wait their turn: these heaps heat and spoil, and when crushed, produce only an acrid rancid oil.

98

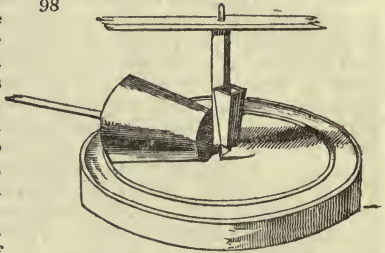

707. *The vine* is cultivated in every province of Spain, and chiefly in those of the east and south. The old sherry wine, *xeres seco*, the sherry sac of Shakspeare, is produced in Valencia and Granada, and especially near Malaga. On the hills surrounding this city are upwards of seven thousand vineyards, cultivated by the proprietors, or by petty tenants, who pay their rent monthly when in money; or during harvest when in kind. The first gathering of grapes commences in the month of June, and these are dried in the sun, and form what are known in Europe as Malaga raisins. A second crop is gathered in September, and a wine made from it resembling sherry; and a third in October and November, which furnishes the wine known on the continent as Malaga, and in England as mountain. In Valentia the grapes for raisins are steeped in boiling water, sharpened with a ley made from vine stems, and then exposed in the air, and suspended in the sun till they are sufficiently dry.

708. *The sugar-cane* (*Saccharum officinarum*) is cultivated to a considerable extent in Malaga and other places, and the ground is irrigated with the greatest care. The sugar produced resembles that of Cuba, and comes somewhat cheaper than it can be procured from the West India islands. Sugar has been cultivated in Spain upwards of seven hundred years; and Jacob is of opinion that capital only is wanted, to push this branch of culture to a considerable extent.

709. *The white mulberry* is extensively grown for rearing the silkworm, especially in Murcia, Valentia, and Granada. The silk is organised into stuffs and ribbons in Malaga.

710. *Of other fruits cultivated* may be mentioned the fig, which is grown in most parts of Spain, and the fruit used as food, and dried for exportation. The gum cistus (*Cistus ladaniferus*, fig. 99.) grows wild, and the gum which exudes from it is eaten by the common people. The caper shrub grows wild, and is cultivated in some places. The orange and lemon are abundant, and also the pomegranate.

99

711. *Other productions*, such as coffee, cotton, cocoa, indigo, pimento, pepper, banana, plantain, &c., were cultivated in Granada for many ages before the West Indies or America was discovered, and might be carried to such an extent as to supply the whole or greater part of Europe.

712. *The rotations of common crops* varies according to the soil and climate. In some parts of the fertile plains of Malaga, wheat and barley are grown alternately without either fallow or manure. The common course of crops about Barcelona, according to Townsend, is, 1. wheat, which, being ripe in June, is immediately succeeded by 2. Indian corn, hemp, millet, cabbage, kidneybeans, or lettuce. In the second year the same crops are repeated; and in the third, barley, beans, or vetches takes place of the wheat. In this way six valuable crops are obtained





in three years. Wheat produces ten fold ; in rainy seasons fifteen ; and in some places as much as fifty for one. Near Carthagera the course is wheat, barley, and fallow. For wheat they plough thrice, and sow from the middle of November to the beginning of December ; and in July they reap from ten to one hundred for one as the season happens to be dry or humid. The Huerta, or rich vale, of Alicant, yields a perpetual succession of crops. Barley is sown in September, and reaped in April ; succeeded by maize, reaped in September, and that by a mixed crop of esculents. Wheat is sown in November, and reaped in June ; flax sown in September is pulled in May. In the vale of Valentia, wheat yields from twenty to forty ; barley from eighteen to twenty four fold ; oats from twenty to thirty fold ; maize, one hundred fold ; rice, forty fold.

713. *The live stock of the Spanish agriculturist* consists of oxen, asses, and mules, as beasts of labour ; sometimes, also, horses are used on the farm, but those are chiefly reared for the saddle and the army. During the reign of Philip II. an act was passed forbidding their use even in coaches. The horses of Andalusia are celebrated : they are deep-chested, somewhat short-backed ; rather heavy about the legs, but with a good shoulder. In general their appearance is magnificent when accoutred for the field. But for the last half century their numbers have been diminishing. The mules and asses are large, and carry heavy loads. The Spanish cows are an esteemed breed, resembling those of Devonshire. They are used chiefly for breeding, there being little use made of cows' milk in most parts of Spain : they are sometimes also put into the plough and cart. Goats are common about most towns, and furnish the milk used in cookery.

714. *The sheep of Spain* have long been celebrated. Pliny relates, that in his time Spanish clothes were of an excellent texture, and much used in Rome. For many centuries the wool has been transported to Flanders, for the supply of the Flemish manufactories, and afterwards to England, when the same manufacture was introduced there. By far the greater part of Spanish sheep are migratory, and belong to what is called the mesta or Merino corporation ; but there are also stationary flocks belonging to private individuals in Andalusia, whose wool is of equal fineness and value. The carcase of the sheep in Spain is held in no estimation, and only used by the shepherds and poor.

715. The term *mesta*, (*meslin*, Eng.) in general signifies a mixture of grain ; but in a restricted sense an union of flocks. This collection is formed by an association of proprietors of lands, and originated in the time of the plague in 1350. The few persons who survived that destructive outrage, took possession of the lands which had been vacated by the death of their former occupiers ; united them with their own ; converted nearly the whole to pasturage ; and confined their attention principally to the care and increase of their flocks. Hence, the immense pastures of Estramadura, Leon, and other provinces ; and the prodigious quantity of uncultivated lands throughout the kingdom. Hence, also, the singular circumstance of many proprietors possessing extensive estate without any titles to them.

716. *The flocks which form the mesta* usually consist of about 10,000 sheep. Each flock is under the care of a directing officer, fifty shepherds, and fifty dogs. The whole flocks composing the mesta, consist of about five millions of sheep, and employ about 45 or 50,000 persons, and nearly as many dogs. The flocks are put in motion the latter end of April, or beginning of May, leaving the plains of Estramadura, Andalusia, Leon, Old and New Castile, where they usually winter ; they repair to the mountains of the two latter provinces, and those of Biscay, Navarre, and Arragon. The sheep, while feeding on the mountains, have occasionally administered to them small quantities of salt. It is laid upon flat stones, to which the flocks are driven, and permitted to eat what quantity they please. During the days the salt is administered the sheep are not allowed to depasture on a calcareous soil, but are moved to argillaceous lands, where they feed voraciously.

717. *At the end of July* the ewes are put to the rams, after separation has been made of those already with lamb. Six or seven rams are considered sufficient for one hundred ewes.

718. *In September* the sheep are ochred, their backs and loins being rubbed with red ochre, or ruddle, dissolved in water. This practice is founded upon an ancient custom, the reason of which is not clearly ascertained. Some suppose, that the ochre uniting with the oleaginous matter of the fleece, forms a kind of varnish, which defends the animal from the inclemency of the weather. Others think the ponderosity of this earth prevents the wool growing too thick and long in the staple. But the more eligible opinion is, that the earth absorbs the superabundant perspiration, which would otherwise render the wool both harsh and coarse.

719. *Towards the end of September* the flocks recommence their march. Descending from the mountains, they travel towards the warmer parts of the country, and again repair to the plains of Leon, Estramadura, and Andalusia. The sheep are generally conducted to the same pastures they had grazed the preceding year, and where most of them had been yeaned : there they are kept during the winter.

720. *Sheep-shearing* commences the beginning of May, and it is performed while the sheep are on their summer journey, in large buildings called *esquileos*. Those, which are placed upon the road, are capable of containing forty, fifty, and some sixty thousand sheep. They are erected in various places ; but the principal are in the environs of Segovia, and the most celebrated is that of *Iturviaca*. The shearing is preceded by a pompous prepa-

ration, conducted in due form, and the interval is considered a time of feasting and recreation. One hundred and twenty-five men are usually employed for shearing a thousand ewes, and two hundred for a thousand wethers. Each sheep affords four kinds of wool, more or less fine according to the parts of the animal whence it is taken. The ewes produce the finest fleeces, and the wethers the heaviest: three wether fleeces ordinarily weigh on the average twenty-five pounds; but it will take five ewe fleeces to amount to the same weight.

721. *The journey which the flocks make in their peregrination is regulated by particular laws, and immemorial customs.* The sheep pass unmolested over the pastures belonging to the villages and the commons which lie in their road, and have a right to feed on them. They are not, however, allowed to pass over cultivated lands; but the proprietors of such lands are obliged to leave for them a path ninety varas, or about forty toises (eighty-four yards), in breadth. When they traverse the commonable pastures, they seldom travel more than two leagues, or five and a half miles a day; but when they walk in close order over the cultivated fields, often more than six varas, or near seventeen miles. The whole of their journey is usually an extent of one hundred and twenty, thirty or forty leagues, which they perform in thirty or thirty-five days. The price paid for depasturing the lands, where they winter, is equally regulated by usage, and is very low; but it is not in the power of the landed proprietors to make the smallest advance.

722. *The mesta has its particular laws, and a tribunal before which are cited all persons who have any suit or difference with the proprietors.* The public opinion in Spain has long been against the mesta, on account of the number of people it employs, the extent of land it keeps uncultivated, the injury done to the pasture and cultivated lands of individuals, and the tyranny of the directors and shepherds. These have been grievances for time immemorial. Government yielding to the pressing solicitations of the people, instituted a committee to enquire into them about the middle of the eighteenth century; but it did no good, and it was not till the revolution of 1810, that the powers and privileges of the mesta were greatly reduced.

723. *The implements of Spanish agriculture are very simple.* The common plough of Castile, and most of the provinces, (fig. 100.) is supposed to be as old as the time of the Romans. It is thus described by Townsend: "The beam is about three feet long, curved, and tapered at one end, to receive an additional beam of about five feet, fastened to it by three iron collars; the other end of the three-foot beam touches the ground, and has a mortise to receive the share, the handle, and a wedge." From this description it is evident that the beam itself supplies the place of the sheath; the share has no fin, and instead of a mould-board, there are two wooden pins fastened near the heel of the share. As in this plough, the share, from the point to its insertion in the beam, is two feet six inches long, it is strengthened by a retch. That used near Malaga, is described by Jacob, as "a cross, with the end of the perpendicular part shod with iron. It penetrates about six inches into the soil, and is drawn by two oxen with ropes fastened to the horns. The plough of Valentia, on the eastern coast, we have already given (fig. 12.), as coming the nearest to that described by Virgil. There are many wheels and other contrivances used for raising water; the most general, as well as the most primitive, is the noria (fig. 101.), or bucket-wheel, introduced by the Moors,

100

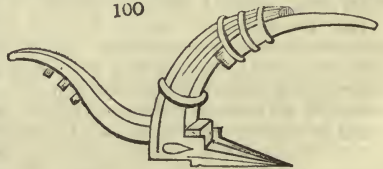

and from which our chain pump is evidently derived. A vertical wheel over a well has a series of earthen jeers, fastened together by cords of esparto, which descend into the water, and fill themselves by the motion of the wheel, they rise to the surface, and then by the same motion empty themselves into a trough, from which the water is conveyed by trenches into the different parts of the garden or field. The

101

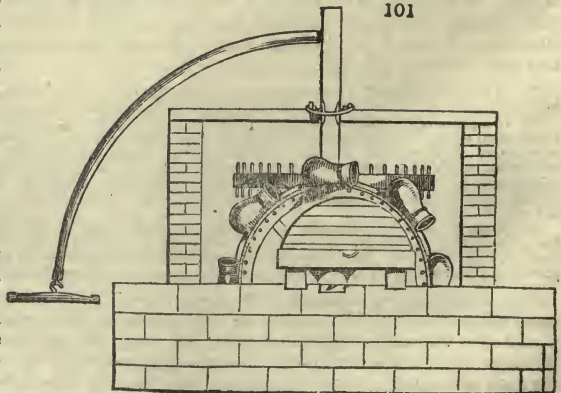

vertical wheel is put in motion by a horizontal one, which is turned by a cow." (*Jacob's Travels*, 152.) The construction of dung-pits has already been mentioned, (689.) as introduced by the Moors, and the practice of preserving the dung in that manner is still continued in Granada and Valentia. Threshing-floors are made in the fields, and paved with pebbles or other stones.

724. Few of the operations of Spanish agriculture afford any thing characteristic. No hay is made in Spain; but so dry and brittle is the straw, that in the process of treading out, which is generally done by mares and colts, it is broken to pieces and the grain separated, the straw put in stacks, and preserved for litter, or mixed with barley as food for cattle. Irrigation is carefully performed, and is the only effectual mode of insuring a crop of grain, or any sort of herbaceous vegetable. On some farms on the Vega in Malaga, scarcely any attention is paid to stirring the soil, but by the very complete irrigation which can be there given, the lands yield fifty bushels per acre. Where the soil is naturally light, situated in a warm climate, and not irrigated, it is remarkably free from weeds; because from the latter end of May, or the beginning of June, when the crop is harvested till October or November, they have no rain; and the heat of the sun during that period destroys every plant, and leaves the soil like a fallow which only requires the seed furrow. In effect it gets no more; and thus under such circumstances, one crop a year after only one ploughing, may be raised for an endless period. — In the Asturias, after the women milk the sheep, they carry it home in leather bags, shaking it all the way till by the time of their arrival butter is formed. (*Townsend's Travels*, i. 273.)

725. The laboring man of Spain adopts a custom which might be useful to the reapers and haymakers of Britain, in many situations. The labor and heat of haytime and harvest excite great perspiration and consequent thirst, which is often obliged to be quenched with sun-warmed water. To cool such water, the Spanish reaper puts it in a porous earthen pitcher (*alcarazas*), the surface of which being constantly moist with the transudation of the fluid, its evaporation cools the water within. The frequent application of wet cloths to a bottle or earthen vessel, and exposure to the sun and wind, effects the same object, but with more trouble.

726. The culture of forests is very little attended to in Spain. The best charcoal is made from heath, chiefly the *Erica mediterranea*, which grows to the size of a small tree, and of which there are immense tracts like forests. The cork-tree (*Quercus suber*, fig. 102.) affords the most valuable products. The bark is taken off for the first time when the tree is about fifteen years old; it soon grows again, and may be re-barked three times, the bark improving every time till the tree attains the age of thirty years. It is taken off in sheets or tables, much in the same way as oak or larch bark is taken from the standing trees in this country. After being detached, it is flattened by presenting the convex side to heat, or by pressure. In either case it is charred on both surfaces to close the transverse pores previously to its being sold. This charring may be seen in bungs and taps; but not in corks, which, being cut in the length way of the wood, the charring is taken off in the rounding.



727. The exertions that have been made for the improvement of the agriculture of Spain, we have already noticed, and need only add, that if the late government had maintained its power, and continued in the same spirit, perhaps every thing would have been effected that could be desired. Time, indeed, would have been requisite; but improvement once heartily commenced, the ratio of its increase is astonishing. But the French invasion of Spain has spoiled every thing, and for the present almost annihilated hope.

728. The agricultural circumstances of Portugal have so much in common with those of Spain, that they do not require separate consideration. The two countries differ in the latter, having a more limited cultivation. The sugar-cane, and most of the West India plants grown in Spain, requiring a warmer climate than that of Portugal. The vine and orange are cultivated to great perfection; but common agriculture is neglected. The breed of horses are inferior, and there are few cows or sheep. Swine is the most abundant live-stock, and fatten, in a half wild state, on the acorns of the numerous oak-forests which cover the mountains.

SUBSECT. 1. *Present State of Agriculture in European Turkey.*

729. *The Turkish empire includes a variety of climates and countries, of most of which so little is correctly known, that we can give so satisfactory account of their agriculture. Asiatic Turkey is nearly three times the extent of the European part; but the latter is better cultivated and more populous. European Turkey, Thornton observes, depends upon no foreign country for its subsistence. The labor of its inhabitants produces in an abundance unequalled in the other countries of Europe, all the alimentary productions, animal and vegetable, whether for use or enjoyment. The corn countries, in spite of the impolitic restrictions of the government, besides pouring plenty over the empire, secretly export their superfluities to foreign countries. Their agriculture, therefore, though neglected and discouraged, is still above their wants.*" (*Present State of Turkey*, vol. i. 66.)

730. *The climate and seasons of European Turkey vary with the latitude and local circumstances of the different provinces from the Morea, in lat. 37°, and surrounded by the Mediterranean sea, to Moldavia, between Hungary and Russia, in lat. 48°. The surface is generally mountainous, with plains and vales; and some rivers, as the Danube in Wallachia, and numerous gulfs, bays, estuaries, and inlets of the Adriatic, the Archipelago, Mediterranean, and Black Seas. The soil is in general fertile, alluvial in some of the richest plains of Greece, as Thessaly; and calcareous in many parts of Wallachia and Moldavia. These provinces produce excellent wheat and rich pasture; while those of the south produce maize, wheat, and rice. The vine is cultivated in most provinces; and there are extensive forests, especially in the north. The live stock is the horse, ox, camel, sheep, and swine.*

731. *Some traits of the agriculture of the Morea, the southernmost province of European Turkey, has been given by Dr. Pouqueville. The climate holds the exact medium between the scorching heat of Egypt and the cold of more northern countries. The winter is short, but stormy; and the summer is hot, but tempered by breezes from the mountains or the sea. The soil of the mountains is argillaceous; in some places inclining to marl, and in others to peat or vegetable earth: the richest parts are Arcadia and Argos. The plough consists of a share, a beam, and a handle, (fig. 103.); the share is shaped somewhat like the claw of an anchor, and the edges armed with iron. In some cases it has two wheels. It is drawn by one horse, two asses, or by oxen or buffaloes, according to the nature of the soil. The corn grown is of excellent quality, though no attention is paid to selecting the seed. The rice of Argolis is held at Constantinople the next in excellence to that of Damietta. The vine is successfully cultivated; but at Corinth, "situated in a most unwholesome atmosphere," the culture of that sort which produces the raisins of Corinth is less attended to than formerly. The olive-trees (*Olea Europæa*, fig. 104.) are the finest in the world; the oil of Maina is the best, and held in esteem at all the principal markets of Europe. The white mulberry is extensively cultivated for the support of the silk-worm. Ellis yields the best silk. The cotton is cultivated in fields, which are commonly divided by hedges of Nepal or Indian fig, which is eaten, but is here more vapid than in Egypt.*

732. *The figs of the Morea "are perhaps the most exquisite that can be eaten." The tree is cultivated with particular care, and the practice of caprifigging adopted. They collect the little figs which have fallen from the trees while very young, and which contain numbers of the eggs of the gnat insect, (*Cynips*). Of these they make chaplets, which are suspended to the branches of the trees. The gnats are soon hatched, and spread themselves over the whole tree. The females, in order to provide a nidus for their eggs, pierce the fruit with their sting, and then deposit them. From this puncture a gummy liquor oozes; and after this the figs are not only not liable to fall, but grow larger and finer than if they had not undergone this operation. It is doubted by some modern physiologists whether this process is of any real use, it being now neglected in most fig countries where it was formerly performed. Some allege that it is merely useful as fecundating the blossoms, which most people are aware are situated inside of the fruit, (fig. 105.); others that it promotes precocity, which the puncture of an insect will do in any fruit, and which any one may have observed in the gooseberry, apple, or pear.*

733. *The almond-tree is very productive. The orange tribe abound; and the pomegranates, peaches, apricots, grapes, &c. are of the finest flavor. The banana is cultivated in the gardens, as are melons, dates, and many other fruits. Carobs (*Ceratonia*),*

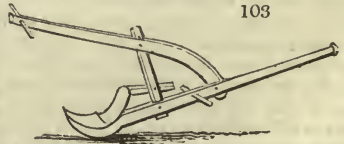

103

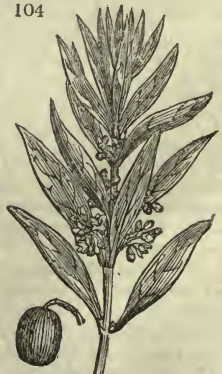

104

quinces, medlars, cherries, &c. are wild in abundance. Bees are found in the hollows of trees; and their excellent white honey is exported.

734. *The oxen of the Morea are low, and have long white hair. The most fleshy do not weigh more than from 3 to 400 pounds. The cows give little milk, and are much injured by the jackals, who tear away their teats; and by large serpents, which suck away all the milk. The sheep are small, and have large horns; wool is considered of the second quality of the wool of the East. Cheese is made from their milk, and that of goats. The horses of the Morea are of a breed between the Moravian and Thracian: their form is not admired; but they are full of fire and courage; and so vigorous, that they run with a firm and rapid step over the mountains without ever stumbling. The asses are miserable.*

105

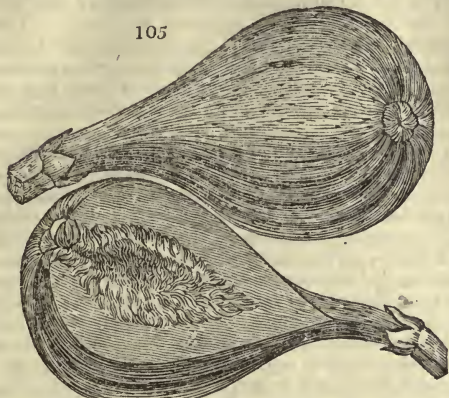

735. *The forests of the Morea produce the cork-tree; the Kermes oak, the quercus esculus or Vallony oak, the acorns of which are eaten, and their cups used as oak-galls, in preparing black dye. The azarole, plane, larch, wild olive, sweet chestnut, manna ash, grains d'Avignon, (rhamnus infectorius, L.), from the grains or seeds of which a fine yellow dye is prepared. Lawsonia inermis, which furnishes a fine aurora color, and with which the women of the East dye their nails, the turpentine tree, barren date trees, silk-tree, (mimosa julibrisia), with its beautiful tufts, pine, fir, and a variety of others. Chestnuts were at one period the temporary food of nearly the whole country. In mount Pholoë, where the peasants are half savages, they form their principal food for the whole year. A variety of plants used in the arts, and in pharmacy, grow wild in the wastes, and there are venison, game, and fishes, in the woods, rivers, lakes, and the surrounding ocean. The Morea, Dr. Pouqueville concludes, is "a fine country;" and though one does not find the golden age here renewed, yet, "under a better order of things it would produce abundantly every thing necessary to supply the wants of man." (Travels, &c. Transl. by A. Plumtree, p. 206.)*

736. *Some notices of the agriculture of Thessaly and Albania have been given by Dr. Holland. The plain of Thessaly (fig. 106.) is an immense tract of level country, with a fine alluvial soil; which tradition and external appearance concur in testifying, was once covered with water. "The capabilities," Dr. Holland observes, "are great throughout the whole of this fine province; and it would not be*

106



easy to fix a limit to the amount and variety of produce which might be raised from its surface. In their present state, the plains of Thessaly form one of the most productive districts of the Grecian peninsula, and their annual produce, in grain of different kinds, cotton, silk, wool, rice, and tobacco, allows a very large amount of regular export from the province. The cultivation is not deficient in skill or neatness. Their plough is of a primitive form; and their carts are small cars, some of them, as Dr. Clarke observes, simple enough (fig. 107.); both are drawn by oxen, or buffaloes. The wool of the sheep is moderately fine; the mulberry is grown in dwarf pollards; and the cotton in drills, well hoed. The men are a stern looking race

107

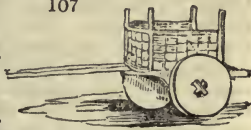

108



(fig. 108.), and the women (fig. 109.) well made, and not unlike the antique. "The circumstances by which the amount of produce might be increased, are chiefly, perhaps, of a more general nature—a better form of government; greater security to private property; a more uniform distribution of the inhabitants; and the prevention of those monopolies in the export of grain, which

109



have hitherto been exercised by the Turkish rulers of the country." (*Travels, &c.* 2d edit. p. 281.)

737. *The agriculture of Albania* differs in no essential particular from that of Thessaly. The common tenure on which land is let, is that of paying to the landlord half the produce. The vale of Deropuli is the most fertile and populous in Albania. The tillage, generally speaking, is remarkable for its neatness. The products are chiefly wheat, maize, tobacco, and rice. The returns afford a considerable surplus for exportation; and the tobacco is esteemed the best in Albania. Large flocks of sheep feed on the declivity of the mountains; and afford much coarse wool for the manufactures of the country.

738. *The agriculture of Moldavia and Wallachia*, two of the most northerly provinces of European Turkey, has been given by various authors, as Carra, Bauer, and Thornton. The climate of those provinces is very severe in winter. Spring begins in April; summer in June; and in July and August the days are excessively hot, and the nights cold. Heavy rains begin in September, and snows in November. The surface is generally mountainous; but the vallies dry and rich. The usual grains are cultivated, and also maize. They plough deep with six oxen, and never employ manure. They take a crop, and leave the land to rest alternately. The corn is trodden out by horses, and then laid up in pits. Flax and hemp are sown for local manufacture. Newly broken-up lands are planted with cabbages, which grow to a great size. The vine is cultivated on the southern declivities of hills, and the wine is said to equal that of Hungary. The mulberry is cultivated for the silkworm; and forests are extensive on the mountains. The common fruit trees are abundant, and an excellent variety of apple, called the doiniasca, grows wild. The olive and fig are too delicate for the climate.

739. *But the pasture lands* are the most valuable parts of these provinces. The oxen are large and fleshy, and so numerous, that they form a principal article of export to Russia, Poland, and Germany. The buffalo thrives better here than in most parts of Europe; and is valued for its strength and milk. The sheep winter on the Danube, and pass the summer on the Carpathian mountains; their mutton is excellent, and the annual exportation of the wool into Germany is very considerable. There are various breeds of horses; they are brought up in great numbers, for the Austrian and Prussian cavalry. They are well formed, spirited, docile, and remarkable for the soundness of their hoofs. The carriage and draught horses are small but active, and capable of resisting fatigue. They live in the open air in all seasons, though in winter they are often attacked by wolves. Domestic fowls and game abound, especially hares. The honey and wine are of the finest quality. One author (Curra) mentions a kind of green wax, which, when made into tapers, diffuses an excellent perfume when lighted. Many of the cottages partake of the Swiss character, and are more picturesque than those of Hungary or Russia (*fig. 110.*)

740. *The poorest agriculture in European Turkey* is that of Romelia, including the country round Constantinople. The surface is hilly, and the soil dry and stony, chiefly in pasture or waste. "The capital of the empire," Thornton observes, "as the soil in its immediate vicinity is barren and ungrateful, receives from the neighbouring villages, and from the surrounding coasts of both the seas which it commands, all the culinary herbs and fruits of excellent flavor, which the most fastidious appetites can require; and from the Asiatic coasts of the Black Sea, all materials necessary for fuel, or for the construction of ships and houses."



## CHAP. V.

### *Modern History and present State of Agriculture in the British Isles.*

741. Having, in the preceding chapter, brought down the history of British agriculture to the revolution, we shall resume it at that period, and continue our view to the present time. As this period may be considered the most interesting of the whole series, we shall, for the sake of distinctness, arrange the matter under the separate sec-

tions of the political, professional, and literary history of agriculture in Britain, and submit a separate view of the progress and present state of agriculture in Ireland.

SECT. I. *Political History of Agriculture in Britain from the Revolution in 1668, to the present Time.*

742. *That the agriculture and general prosperity of this country were greatly benefited by the revolution is an indisputed point.* That prosperity, as far as respects agriculture, is chiefly to be ascribed to the judicious corn-laws then promulgated. "In 1670," a masterly writer on the subject remarks, "exportation was permitted, whatever the price might be; and importation was virtually prohibited, by a duty of 16s. per quarter, when wheat did not exceed 53s. 4d.; of 8s. when above that, and not exceeding 80s.; and when above 80s. the duty of 5s. 4d., imposed by the act 1663, continued to be payable. Still, however, as there was a duty payable on exportation; and as importation, from some defect in the law respecting the mode of ascertaining the prices at which the different duties were exigible, still continued at the low duty, the system by which exportation was encouraged, and importation in ordinary cases prohibited, was not completely established till 1688 and 1700. In the former of these years, a bounty of 5s. a quarter was given on exportation, when the price of wheat did not exceed 48s., and in the latter the duties on exportation were wholly repealed. Under these laws, not only was the excess of exports very considerable, but the prices of grain, down to 1765, were much lower than during an equal number of years preceding 1688. This is not the place to inquire how far these laws had an influence in producing this phenomenon; but the facts themselves are indisputable. Yet the mere circumstance of large exportations of grain does by no means prove the prosperity of agriculture; far less is its cheapness in the home markets any evidence of the comfortable subsistence of the lower orders. Corn seems to have been raised in such abundance, not merely because the market was extended by means of the bounty, but because there was little demand for other products of the soil, which have, since that time, withdrawn a large portion of the best arable land from the growth of corn. And the price was low, because neither the number nor wealth of the consumers had increased in a proportion corresponding to the supply. Before the accession of his present majesty, the number of acts for inclosure was only two hundred and forty-four;—a clear proof that agricultural improvements proceeded much more slowly than they have done since. And it cannot be disputed, that, owing to the imperfect culture of that period, when ameliorating crops did not enter largely into the courses of management, any given extent of land did not produce so much corn as under the improved rotations of modern husbandry."

743. *The exportation of wool was prohibited in 1647, in 1660, and in 1688; and the prohibition strictly enforced by subsequent statutes.* The effect of this on its price, and the state of the wool trade, from the earliest period to the middle of last century, are distinctly exhibited by the learned and laborious author of *Memoirs on Wool*, printed in 1747.

744. *In 1765, the corn-laws established in the end of the seventeenth century began to be repealed, and exportation was prohibited, and importation permitted, without payment of duties, by annual acts, during the seven subsequent years.* "A new system was established in 1773, allowing importation when the price of wheat was at or above 48s. per quarter, at the low duty of 6d. Exportation was prohibited when the price was 44s.; and below that, the former bounty of 5s. per quarter continued to be payable."

745. *By an act passed in 1791, the bounty on exportation, when the price was under 44s. per quarter, remained unaltered; but "exportation was permitted till the price was 46s. Importation was virtually prohibited by high duties when the price was below 50s.; and permitted, on payment of a duty of 6d., when at or above 54s."*

746. *In 1804, "the corn-laws were altered for the third time, and the bounty on exportation was paid till the price of wheat was 48s. per quarter; and at 54s. exportation was prohibited. The high duty of 24s. 3d. was payable on importation till the price was 63s.; above 63s. and under 66s., a duty of 2s. 6d.; and above 66s. the low duty of 6d. By an act in 1805, importation into any part of Britain is to be regulated by the aggregate average price of the twelve maritime districts of England. Importation was never stopt under the law of 1804, till February 1815.*

747. *During the twenty-two years preceding 1821, about sixty millions of pounds sterling have been paid for foreign grain. "In bad seasons the prices have been enhanced to a most alarming degree, notwithstanding large bounties have been paid on importation. The average price of every successive period of ten years since 1765, has risen considerably; and since 1795, the price has been seldom less than double the average of the first sixty years of the last century."*

748. *The corn-laws have recently undergone another change, after much discussion in parliament, and a very general opposition on the part of the manufacturing and commercial classes, with a great number of publications on both sides, which will probably be not more lasting than those that have preceded it.* By the 54th of the king, c. 69., (17th June, 1814,) the exportation of corn, meal, malt, and flour, from any part of the united kingdom, is permitted at all times, without payment of any duty, or receiving any bounty; and by the 55th, c. 26., (23d March, 1815,) importation is prohibited, (except for the warehouse, from whence it may be taken out for sale, when the prices are such as would permit importation,) till the price of wheat is 80s.; rye, pease, and beans, 53s.; barley, bear, or bigg, 40s.; and oats 27s. per quarter. Above these prices, these different kinds of corn are admitted, without payment of any duty whatever.

From the British colonies in America, corn may be imported for home-consumption, without payment of any duty, when the prices are at or above, wheat, 67s.; rye, pease, and beans, 44s.; barley, bear, or bigg, 33s.; and oats, 22s. per quarter. Almost all the restrictions on the inland corn trade were removed by the act, 1772; and the more just views of the present age have given freedom to the trade, in point of fact, though some of the old laws against forestalling, &c., are still unrepealed. Yet it is not many years since punishments were inflicted for these imaginary crimes. (*Ency. Brit. art. Agr.*)

749. *Agriculture in Scotland* was at a low ebb at the period of the revolution. "The calamity of that evil had so oppressed the tenantry of Scotland, that many farms remained unoccupied. Proprietors were then as eager in searching after tenants who were able to stock and cultivate the ground, as farmers are now assiduous in seeking after farms. Improvements began to be made soon after the union, especially by some gentlemen of East Lothian, and by the efforts of the agricultural society of Scotland, established in 1723. It was now found beneficial to grant long leases, which were found greatly to increase the skill and industry of the tenants, by rendering them secure of enjoying the benefit of their improvements. A great stimulus was also given to farmers by the money circulated during the rebellion of 1745, which raised prices, and increased the tenants' capital stock.

750. *A desire to improve the roads of Scotland* now began to manifest itself among the proprietors. The first act of parliament for collecting tolls on the highways in Scotland, was passed in 1750, for repairing the road from Dunglass bridge to Haddington. In ten years after, several acts followed for the counties of Edinburgh and Lanark, and for making the roads between Edinburgh and Glasgow. The benefit which agriculture has derived from good roads it would not be easy to estimate. The want of them was one great cause of the slow progress of the art in former times. At present, all the improvements introduced by M'Adam in the construction and preservation of the roads of England, are spreading with equal rapidity and good effect in Scotland.

751. *The relaxing of the rigor of entails, and abrogating the feudal system* greatly benefited the agriculture of Scotland. The first was effected by an act in 1770, which relaxed the rigor of strict entails, and extended the powers of proprietors, in so far as regards the improvement of their estates, and the granting of leases. The legal abrogation of the feudal system, by passing the jurisdiction act, was of material advantage, in so far as the security of cultivators was thus increased, and their situation rendered infinitely more independent than in former times.

752. *But the general progress of agriculture in Britain* from the revolution to the middle of the eighteenth century, was by no means so considerable as from the great exportation of corn we should be led to imagine. The gradual advance in the price of land produce, soon after the year 1760, occasioned by the increase of population, and of wealth derived from manufactures and commerce, has given a more powerful stimulus to rural industry, augmented agricultural capital in a greater degree, and called forth a more skilful and enterprising race of cultivators, than all the laws for regulating the corn trade could ever have effected. Most of the inventions for increasing produce and economising labor have either been introduced, or improved and greatly extended since that time; and by means of both, the free surplus has been vastly increased for the supply of the general consumption. The passing of more than three thousand bills of inclosure, in the late reign, is a proof how much more rapidly the cultivation of new land has proceeded than in the former period; and the garden-like appearance of the country, as well as the striking improvement in the condition of all classes of the rural population, display, in the most decided manner, the skill and the success with which this great branch of national industry is now followed throughout the greater part of Britain."

753. *Since the conclusion of the American war in 1782*, "improvement has proceeded with singular rapidity in every district; and while the rental rolls of proprietors have been doubled, tripled, and quadrupled, the condition of the tenantry, and of the lower ranks, has been ameliorated almost in a proportional degree." (*Ed. Ency. art. Agr.*)

754. *Since the peace of 1815, agriculture has sustained a severe shock* from the fall of prices, occasioned by the lessened circulation of currency, the necessary preliminary to a return to a currency of the precious metals. In this shock many hundreds of farmers lost all their capital, and were obliged to become operatives to others; while some, more fortunate, contrived to retain as much of the wreck of their property as enabled them to emigrate to other countries. Cleghorn, whose pamphlet on the depressed state of agriculture was honored with the prize of the Highland Society of Scotland, thinks this loss cannot have been less than one year's rental of the whole island. "The replies sent to the circular letter of the Board of Agriculture, regarding the agricultural state of the kingdom, in February, March, and April, 1819, furnish a body of evidence which cannot be controverted, and exhibit a picture of widely spread ruin among the agricultural classes, and of



distress among all that immediately depend upon them, to which there is probably no parallel." (See *Cleghorn on the Depressed State of Agriculture*, 1822.) After seven or eight years of severe suffering, both by landlords and tenants, things have now assumed a more stationary condition. Rents have been greatly lowered every where, in proportion to the fall of prices and the rise of parochial burdens, and both farmers and landlords are beginning gradually to recover themselves.

SUBJECT. 1. *Professional History of Agriculture, from the Revolution to the present Time.*

755. From the restoration down to the middle of the eighteenth century, very little improvement had taken place, either in the cultivation of the soil, or in the management of live stock. Even clover and turnips (the great support of the present improved system of agriculture,) were confined to a few districts, and at the latter period were scarcely cultivated at all by common farmers in the northern parts of the island. From the *Whole Art of Husbandry*, published by Mortimer in 1706, a work of considerable merit, it does not appear that any improvement was made on his practices till near the end of last century. In those districts where clover and rye-grass were cultivated, they were cut green and used for soiling as at present. Turnips were sown broadcast, hand-hoed, and used for feeding sheep and cattle, as they were used in Houghton's time, and are still in most districts of England.

756. In the beginning of the eighteenth century, a considerable improvement in the process of culture was introduced by Jethro Tull, a gentleman of Berkshire, who began to drill wheat and other crops, about the year 1701, and whose *Horse-hoeing Husbandry* was published in 1731. "In giving a short account of the innovations of this eccentric writer, it is not meant to enter into any discussion of their merits. It will not detract much from his reputation to admit, that, like most other men who leave the beaten path, he was sometimes misled by inexperience, and sometimes deceived by a too sanguine imagination. Had Tull confined his recommendation of the drill husbandry to leguminous and bulbous-rooted plants generally, and to the cereal gramina only in particular circumstances; and had he, without puzzling himself about the food of plants, been contented with pointing out the great advantage of pulverizing the soil in most cases, and extirpating weeds in every case, he would certainly have deserved a high rank among the benefactors of his country. A knowledge of his doctrines and practice, however, will serve as a necessary introduction to the present approved modes of culture."

757. Tull's theory is promulgated with great confidence; and in the controversy which he thought proper to maintain in support of it, he scrupled not to employ ridicule as well as reasoning. Besides the Roman writers *de Re Rustica*, Virgil in particular, whom he treats with high disdain; he is almost equally severe on Dr. Woodward, Bradley, and other writers of his own time.

758. Tull begins by showing that the roots of plants extended much farther than is commonly believed; and then proceeds to inquire into the nature of their food. After examining several hypotheses, he decides this to be fine particles of earth. The chief, and almost the only use of dung, he thinks, is to divide the earth; to dissolve the "terrestrial matter which affords nutriment to the mouths of vegetable roots;" and this can be done more completely by tillage. It is therefore necessary, not only to pulverize the soil by repeated ploughings before it be seeded; but as it becomes gradually more and more compressed afterwards, recourse must be had to tillage while the plants are growing, or *horse-hoeing*; which also destroys the weeds that would deprive the plants of their nourishment.

759. The leading features of Tull's husbandry, are his practice of laying the land into narrow ridges of five or six feet, and upon the middle of these, drilling one, two, or three rows; distant from one another about seven inches, when there were three; and ten inches, when only two. The distance of the plants on one ridge from those on the contiguous one, he called an *interval*; the distance between the rows on the same ridge a *space*, or partition: the former was stirred repeatedly by the horse-hoe, and the latter by the hand-hoe.

760. The extraordinary attention Tull gave to his mode of culture is, perhaps, without a parallel. "I formerly was at much pains," he says, "and at some charge, in improving my drills, for planting the rows at very near distances; and had brought them to such perfection, that one horse would draw a drill with eleven shares, making the rows at three inches and a half distance from one another; and, at the same time, sow in them three very different sorts of seeds, which did not mix; and these two at different depths. As the barley-rows were seven inches asunder, the barley lay four inches deep. A little more than three inches above that, in the same channels, was clover; betwixt every two of these rows, was a row of saintfoin, covered half an inch deep. I had a good crop of barley the first year; the next year two crops of broad clover, where that was sown; and where hop clover was sown, a mixed crop of that and saintfoin; but I am since, by experience, so fully convinced of the folly of these, or any other mixed crops, and more especially of narrow spaces, that I have demolished these instruments (in their full perfection) as a vain curiosity, the drift and use of them being contrary to the true principles and practice of horse-hoeing." (*Horse-hoeing Husbandry*, p. 62. London, 1762.)

761. In the culture of wheat he began with ridges six feet broad, or eleven on a breadth of sixty-six feet; but on this he afterwards had fourteen ridges. After trying different numbers of rows on a ridge, he at last preferred two, with an intervening space of about ten inches. He allowed only three pecks of seed for an acre. The first hoeing was performed by turning a furrow from the row, as soon as the plant had put forth four or five leaves; so that it was done before, or at the beginning of winter. The next hoeing was in spring, by which the earth was returned to the plants. The subsequent operations depended upon the circumstances and condition of the land, and the state of the weather. The next year's crop of wheat was sown upon the intervals which had been unoccupied the former year; but this he does not seem to think was a matter of much consequence. "My field," he observes, "whereon is now the thirteenth crop of wheat, has shown that the rows may successfully stand upon any part of the ground. The ridges of this field were, for the twelfth crop, changed from six feet to four feet six inches. In order for this alteration, the ridges were ploughed down, and then the next ridges were laid out the same way as the former, but one foot six inches narrower, and the double rows drilled on their tops; whereby, of consequence, there must be some rows standing on every part of the ground, both on the former partitions, and on

every part of the intervals. Notwithstanding this, there was no manner of difference in the goodness of the rows; and the whole field was in every part of it equal, and the best, I believe, that ever grew on it. It is now the thirteenth crop, likely to be good, though the land was not ploughed cross ways." (*Ibid.* p. 424.)

762. According to Tull, a rotation of crops of different species was altogether unnecessary; and he labors hard to prove against Dr. Woodward, that the advantages of such a change, under his plan of tillage, were quite chimerical; though he seems to admit the benefit of a change of the seed itself. But the best method of determining the question would have been, to have stated the amount of his crops per acre, and the quality of the grain, instead of resting the superiority of his management on the alleged saving of expence, when compared with the common broadcast husbandry.

763. On the culture of the turnip, both his principles and his practice are much more correct. The ridges were of the same breadth as for wheat; but only one row was drilled on each. His management, while the crop was growing, differs very little from the present practice. When drilled on the level, it is impossible, he observes, to hoe-plough them so well as when they are planted upon ridges. But the seed was deposited, at different depths, the half about four inches deep, and the other half exactly over that, at the depth of half an inch. "Thus planted, let the weather be never so dry, the deepest seed will come up; but if it raineth immediately after planting, the shallow will come up first. We also make it come up at four times, by mixing our seed, half new and half old, the new coming up a day quicker than the old. These four comings up give it so many chances for escaping the fly; it being often seen, that the seed sown over night will be destroyed by the fly, when that sown the next morning will escape, and *vice versâ*; or you may hoe-plough them when the fly is like to devour them: this will bury the greatest part of those enemies: or else you may drill in another row without new ploughing the land."

764. Drilling, and horse and hand-hoeing, seem to have been in use before the publication of Tull's book. "Hoeing," he says, "may be divided into deep, which is one horse-hoeing; and shallow, which is the English hand-hoeing; and also the shallow horse-hoeing used in some places betwixt rows, where the intervals are very narrow, as sixteen or eighteen inches. This is but an imitation of the hand-hoe, or a succedaneum to it, and can neither supply the use of dung, nor of fallow, and may be properly called scratch-hoeing." But in his mode of forming ridges, his practice seems to have been original; his implements display much ingenuity; and his claim to the title of father of the present horse-hoeing husbandry of Great Britain seems indisputable. A translation of Tull's book was undertaken at one and the same time in France, by three different persons of consideration, without the privity of each other. Two of them afterwards put their papers into the hands of the third, *M. Du Hamel du Monceau*, of the Royal Academy of Sciences, at Paris, who published a treatise on husbandry, on the principles of Tull, a few years after. But Tull seems to have had very few followers in England for more than thirty years. The present method of drilling and horse-hoeing turnips was not introduced into Northumberland till about the year 1780, (*Northumberland Survey*, p. 100.) and it was then borrowed from Scotland, the farmers of which had the merit of first adopting Tull's management in the culture of this root about 1760, and from whom it has since made its way, but slowly, in the southern part of the island.

765. In the live stock of British agriculture, very little improvement had been made previously to the middle of the eighteenth century, or later. About this time, the best breed of cattle and sheep were about Doncaster, in Yorkshire, and in Leicestershire, and the first grand and successful effort to improve them was made by Robert Bakewell, of Dishley in the latter county. Bakewell was born about 1730; and soon after arriving at the years of maturity, took an interest in improving the breed of sheep. His father was a farmer, and died in 1772; but the son had taken an active management of the farm for many years before that period, for we find him letting out rams in 1762. (*Hunt's Agricultural Memoirs*, 35.)

766. By Bakewell's skillful selection at first, and constant care afterwards to breed from the best animals, without any regard to their consanguinity, he at last obtained a variety of sheep, which, for early maturity, and the property of returning a great produce of mutton for the food they consume, as well as for the small proportion which the weight of the offal bears to that of the four quarters, are altogether unequalled either in this or any other country. The Dishley or New Leicester sheep, and their crosses, are now spread over the principal corn districts of Britain; and, from their quiet domesticated habits, are probably still the most profitable of all the varieties of sheep, on farms where the rearing and fattening of live stock are combined with the best courses of tillage crops.

767. The practice of Bakewell and his followers furnishes an instance of the benefits of a division of labor, in a department of business, where it was little to be expected. Their male stock was let out every year to breeders from all parts of England; and thus, by judiciously crossing the old races, all the valuable properties of the Dishley variety descended, after three or four generations, to their posterity. By no other means could this new breed have spread so rapidly, nor have been made to accommodate itself so easily to a change of climate and pasture. Another recommendation of this plan was, that the ram-hirer had a choice among a number of males, of somewhat different properties, and in a more or less advanced stage of improvement; from which it was his business to select

such as suited his particular object. These were reared by experienced men, who gave their principal attention to this branch alone; and having the best females as well as males, they were able to furnish the necessary supply of young males in the greatest variety, to those farmers whose time was occupied with other pursuits. The prices at which Bakewell's rams were hired, appear enormous. In 1789, he received twelve hundred guineas for the hire of three brought at one birth; two thousand for seven; and, for his whole letting, at least three thousand guineas. (*Encyc. Brit. art. Agr.*)

768. *Bakewell died in the beginning of the present century*: his chief coadjutors in the improvement of stock were Cully, and Bailey of Northumberland, whose valuable works on live stock, and other subjects, with some notices of their lives, will be found in the proper place in Part IV. of this work.

769. *Merino sheep* were first brought into England in 1788, when his majesty procured a small flock by way of Portugal. In 1791, another flock was imported from Spain. In 1804, when his majesty's annual sales commenced, this race began to attract much notice. Dr. Parry, of Bath, has crossed the Ryeland or Herefordshire sheep, with the merinos, and brought the wool of the fourth generation to a degree of fineness not excelled by that of the pure merino itself; while the carcase, in which is the great defect of the merinos, has been much improved. Lord Somerville, and many other gentlemen, have done themselves much honor by establishing this race, so necessary to the prosperity of our woollen manufactures, and in removing its defects by their judicious management. (*Encyc. Brit. art. Agr.*)

770. *The other advances made in agriculture subsequently to the middle of the eighteenth century*, are the general improvement of implements, especially of the swing plough, (*fig. 111.*)

111

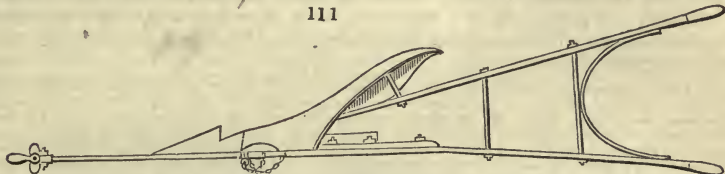

by Small, about 1790; the invention of the best description of threshing machine, (*fig. 112.*) by Meikle, soon afterwards; the improvement of the one horse cart (*fig. 113.*) the invention of several reaping machines, by various artists; the improved method of draining, by Elkington, in 1760; the introduction of the ruta buga, or Swedish turnip, in 1790; of the potatoe tuber into field culture, in 1788; of the rotation of crops, gradually from 1700; the use of summer wheat, in 1800; and the sowing of winter wheat in spring, from 1795. Of these, and a variety of other topics, the historical details will be found where they are respectively treated of, in the course of this work.

112

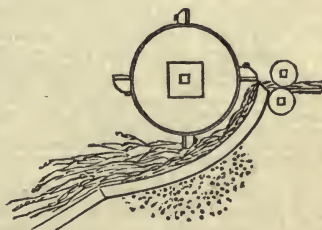

771. *The agriculture of Scotland*, as we have seen (749.), was in a very depressed state at the revolution, from political circumstances. It was not less so in point of professional knowledge. Lord Kaimes, that excellent judge of mankind, and sound agriculturist, declares, in strong terms, that the tenantry of Scot-

113

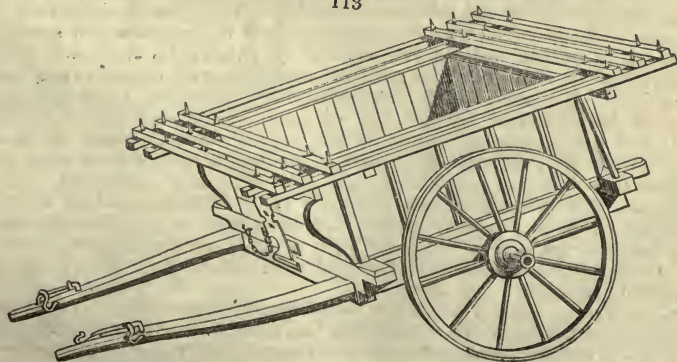

land, at the end of the seventeenth and beginning of the eighteenth century, were so benumbed with oppression or poverty, that the most able instructor in husbandry would have made nothing of them. Fletcher of Salton, who lived in the best part of Scotland, and in the end of the seventeenth century, describes their situation as truly deplorable. In fact, many farms remained unoccupied; even tenants rarely accepted of leases, at least they were shy, unwilling to accept them for any considerable number of years; hence improvement of every kind was totally neglected, and the general poverty of the tenantry necessarily occasioned landed property to be of little value; because, while rents were trifling, they were also ill paid, which of course placed many proprietors in something like a state of mendicacy.

772. *John Cockburn, of Ormiston, East Lothian, a spirited individual*, who arose at this time, and to whom the agriculture of Scotland is much indebted, deserves to be mentioned. He was born in 1685, and succeeded to the family estate of Ormiston in 1714. Cockburn, at an early period of his life, saw the evils of the feudal system; and justly considered the qualities supposed to compose the character of a feudal chieftain as badly calculated to promote internal improvement. He saw that this was only to be done by forming and extending a middle rank of society, and increasing their prosperity. In fact, as an able writer, Brown, the founder of the *Farmer's Magazine*, has remarked, "the middling ranks are the strength and support of every nation. In former times, what we now call middling classes were not known, or at least little known in Scotland, where the feudal system reigned longer than in England. After trade was introduced, and agriculture improved, the feudal system was necessarily overturned; and proprietors, like other men, began to be estimated according to their respective merits, without receiving support from the adventitious circumstances under which they were placed.

773. *When Cockburn succeeded to the estate of Ormiston, in 1714, the art of agriculture was imperfectly understood*, and the condition of the tenantry was so reduced, that it could not be expected to see improvements undertaken, unless the strongest encouragement was previously held out. This was done by Cockburn, even in his father's lifetime. As Robert Wight, one of the Ormiston tenants, had early shown an uncommon spirit to enter into Cockburn's views, being one of the first farmers in Scotland who inclosed by ditch and hedge, and planted hedgerow trees at his own proper charge, he was singled out for favour, and in 1718 received a lease of the Murrays, or Muir-house farm, of an uncommon long endurance. The lease was for thirty-eight years, and the rent 75*l.* Scottish money; but upon paying a fine or grassum of 1200*l.* Scots, at the expiration of that term, a renewal of the lease was to be granted for nineteen years more, and so on from nineteen to nineteen years in all time coming. The two subscribing witnesses to the deed were Sir John Inglis of Cramond, Bart., and John Hepburn, Esq. of Humber, gentlemen invited on the occasion by Cockburn, in order that his example might animate them with the like liberal and patriotic desire to improve the agriculture of their respective properties. Alexander Wight, eldest son of Robert above named, possessed the house of Muir farm by tacit reversion till 1725, at which period, agreeable to the plan adopted for encouraging substantial improvements, a lease was granted to him for thirty-eight years, and three lives therein named. This tenant, like his father, having entered warmly into Cockburn's measures, got that lease cancelled in 1734, when a new one was granted for nineteen years, renewable for every nineteen years in all time coming, upon payment of a fine equal to one year's rent of the premises. These were leading examples to Scottish landlords, and held out to other tenants of the Cockburn estate a noble encouragement to undertake improvements, seeing that their benevolent landlord was so ready to reward them.

774. *Thus the foundation of Scottish improvement was laid by granting long leases*. Many people at this time may think, that such a length of lease was unnecessary, and that the distinguished personage of whom we are speaking might have accomplished his object by granting leases of a more limited endurance. We would request such persons to reflect upon the state of the country, and the actual condition of the tenantry at the period under consideration. We ought not to judge of the prosperity of measures then employed, to introduce and encourage improvement, according to the rules of the present day, when tenants possess knowledge and capital sufficient for carrying through the most difficult and arduous undertakings. Let it also be remembered, that both knowledge and capital were the undoubted result of the ameliorated system then introduced. Cockburn laid the first stone of the system; his brethren in different quarters assisted in rearing the fabric, though, perhaps, their aid was not in one instance so munificent. The success which accompanied it served, however, to convince almost the whole landholders of Scotland, that the surest way of extending improvements was to give the tenantry an interest in their accomplishment. Hence the bond of connection betwixt proprietors and tenants in Scotland is formed upon more liberal principles than prevail in any other country with which we are acquainted. No man in Scotland, at least very few men, will enter to the possession of land unless the security of a lease is previously granted; and proprietors in general are so sensible of the benefit of that tenure, that few of them refuse to grant it for such a number of years as both parties may consider best adapted to the system of management meant to be exercised. (*Ed. Encyc. art. Agr.*)

775. *In 1723, a number of landholders formed themselves into a Society of Improvers in the Knowledge of Agriculture in Scotland*. The Earl of Stair, one of their most active members, is said to have been the first who cultivated turnips in that country. This society had exerted itself in a very laudable manner, and apparently with considerable success, in intro-

ducing cultivated herbage and turnips, as well as in improving on the former methods of culture. But there is reason to believe, that the influence of the example of its members did not extend to the common tenantry, who are always unwilling to adopt the practices of those who are placed in a higher rank, and supposed to cultivate land for pleasure, rather than profit. Though this society, the earliest in the united kingdom, soon counted upwards of three hundred members, it existed little more than twenty years. Maxwell delivered lectures on agriculture for one or two sessions at Edinburgh, which, from the specimens he has left, ought to have been encouraged.

776. *Draining, enclosing, summer-fallowing, sowing flax, hemp, rape, turnip, and grass seeds, planting cabbages after, and potatoes with the plough, in fields of great extent, are practices which were already introduced; and, according to the general opinion, more corn was now grown where it was never known to grow before, than perhaps a sixth of all that the kingdom was in use to produce at any former period.*

777. *The first notice of a threshing machine is given by Maxwell in his Transactions of the Society of Improvers, &c.; it was invented by Michael Menzies, advocate, and he obtained a patent for it. Upon a representation made to the society, that it was to be seen at work in several places, they appointed two of their number to inspect it: and in their report they say, that one man would be sufficient to manage a machine which would do the work of six. One of the machines was "moved by a great water wheel and treddles;" and another, "by a little wheel of three feet in diameter, moved by a small quantity of water." This machine the society recommended to all gentlemen and farmers. (Encyc. Brit. and Ed. Encyc. art. Agr. Brown's Treatise on Rural Affairs, Introduction, &c.)*

778. *Hope, of Rankeillor, was an active and indefatigable member of the Society of Improvers. He had studied agriculture both in England and foreign countries. Among other patriotic and skilful exertions of this gentleman, he drained the morass in the neighborhood of Edinburgh, then known as Straiton's loch;*

114

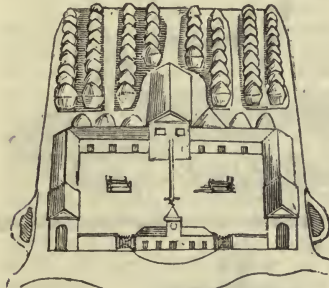

- (1. Barn
- 2. Show-room
- 3. Mill-shed
- 4. Common stable
- 5. Riding horse do.
- 6. Ox feeding-house
- 7. Cow-house
- 8. Hospital stable
- 9. Root and steam-
- ing-house
- 10. Cattle-sheds
- 11. Cart-shed
- 12. Carpenter's shed
- 13. Smith's forge
- 14. Tool-house
- 15. Piggeries
- 16. Poultry
- 17. Well and cis-
- tern
- 18. Farmer's kit-
- chen;
- 19. Common par-
- lor
- 20. Business room
- 21. Entrance)

115

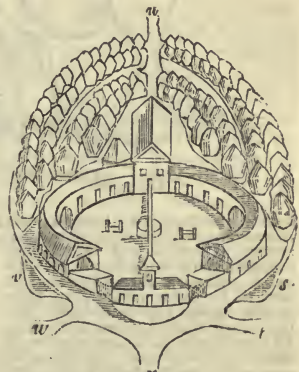

- (a. Corn-barn
- b. Straw end
- c. Mill-shed
- d. Common stable
- e. Riding horse do.
- f. Hospital
- g. Cattle-shed
- h. Cart-shed
- i. Piggeries
- j. Poultry
- k. Piggeries
- l. Tool-house
- m. Carpenter
- n. Smith
- o. Cattle-sheds
- p. Root-house
- q. Cow-house
- r. Ox feeding-house
- s. Washing-pond
- t. Side road
- u. Entrance to rick-
- yard
- v. Pond
- w. Side road
- x. Main entranc

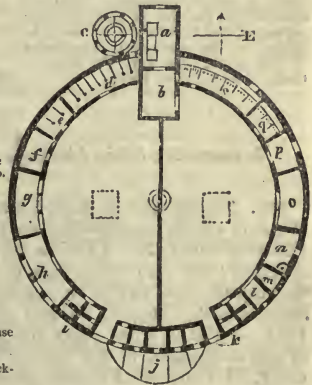
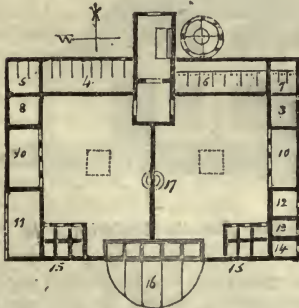

and he projected the walks over the grounds now known as the meadow walks, which were long the most fashionable place of resort for the citizens.

779. *The Dukes of Hamilton and Alhol, Lords Stair, Hopeton, and Islay*, were active members of this society, and especially Cockburn of Ormiston, already mentioned (772.), who was one of its principal promoters and founder.

780. *Dawson, of Frogden in Roxburghshire*, is a man to whom modern agriculture is more indebted than perhaps any other. Dawson studied the Norfolk agriculture for several years, and conceived the happy idea of combining it with the system of Tull, and improving on both. The result was his invention of the culture of turnips on raised drills, with the dung buried directly under the plants. He also extended the use of lime, and of artificial grasses and clovers, and on better principles; and was the first to introduce the practice of ploughing with two horses without a driver. On these improvements depend the superior excellence of what is known as the convertible or Berwickshire husbandry. It is this husbandry which has thrown capital into the hands of the farmers of Scotland, and rendered the profession of farming there more respectable than in England. Scotland also has set the example, not only in improved modes of culture, and in implements and machines; but in the more expensive department of the farm house and offices, numerous examples of which may be there found, both commodious in plan and disposition (figs. 114. and 115.), and elegant in elevation, (fig. 116.) The laying out of the fields of farms, the roads,

116



fences, and water-courses, and especially the management of hedges, has been greatly improved; and the breed of working horses (fig. 117.) cannot be equalled in any other country for strength, activity,

117

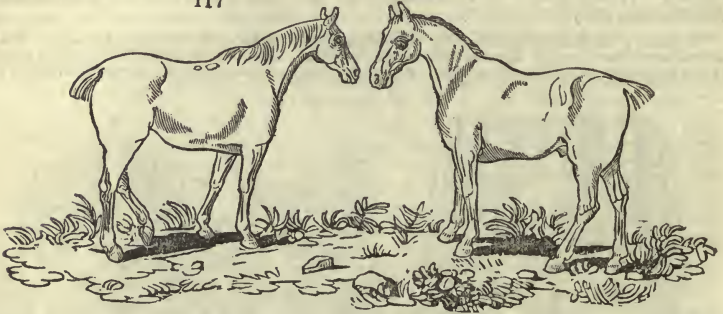

docility, and hardiness. While we state these particulars, we freely admit that the improvement of fattening animals has made incomparably greater progress in England, and also that the cottages of the laboring classes (fig. 118.) are in general more comfortable and neat in the latter country, and their gardens are also better cultivated. But the system of paying farm servants in kind, or chiefly so, almost peculiar to Scotland, far more than counterbalances every advantage which the English cottager at present possesses. We shall describe the practice at length in our survey of the agriculture of East Lothian, in the statistical department of this work. (See Part IV. Book I. Chap. 3. Sect. 3., and Index.

118



SUBJECT. 2. *Of the Literature of British Agriculture from the Revolution to the present time.*

781. *The literature of English agriculture from the revolution* is rich in excellent works. We have already, in detailing the professional improvements, noticed the writings of Mortimer and Tull. To these we now add the numerous works of Bradley, which appeared from 1717 to his death in 1732. They are all compilations, but have been of very considerable service in spreading a knowledge of culture, and a taste for rural improvement. Stephen Switzer, a seedsman in London, in 1729; Dr. Blackwell, in 1741; and Hitt, a few years afterwards, published tracts recommending the burning of clay as manure, in the manner recently done by Governor Beaton, of Suffolk; Craig, of Cally in Kircudbrightshire, and some others. Lisle's useful *Observations on Husbandry*, were published in 1757; Stillingfleet's *Tracts*, in which he shows the importance of a selection of grasses for laying down lands, in 1759; and the excellent

*Essays of Harte*, canon of Windsor, in 1764. The celebrated Arthur Young's first publication on agriculture, entitled, *The Farmer's Letters to the People of England*, &c. appeared in 1767; and was followed by a great variety of excellent works, including the *Tour in France*, and the *Annals of Agriculture*, till his pamphlet on the utility of the Board of Agriculture, in 1810. Marshall's numerous and most superior agricultural works commenced with his *Minutes of Agriculture*, published in 1787, and ended with his *Review of the Agricultural Reports*, in 1816. The last works we shall mention are those of Dr. R. W. Dickson, whose *Practical Agriculture* appeared in two quarto volumes, in 1806, and may be considered as giving a complete view of the present state of agriculture at the time. Other works have appeared subsequently. In this sketch a great number of useful and ingenious authors are necessarily omitted; but they will all be found in their places in the *Literature of British Agriculture*, given in the Fourth Part of this work.

782. *The Scottish writers on agriculture* in that country confirm our view of the low state of the art in the beginning of the eighteenth century. The first work, written by James Donaldson, was printed in 1697, under the title of *Husbandry Anatomised; or, an Enquiry into the present Manner of Teiling and Manuring the Ground in Scotland*. It appears from this treatise that the state of the art was not more advanced at that time in North Britain, than it had been in England in the time of Fitzherbert. Farms were divided into *infield* and *outfield*; corn crops followed one another, without the intervention of fallow, cultivated herbage, or turnips, though something is said about fallowing the outfield; enclosures were very rare; the tenantry had not begun to emerge from a state of great poverty and depression; and the wages of labor, compared with the price of corn, were much lower than at present; though that price, at least in ordinary years, must appear extremely moderate in our times. Leases for a term of years, however, were not uncommon; but the want of capital rendered it impossible for the tenantry to attempt any spirited improvements.

783. *The Countryman's Rudiments; or, an Advice to the Farmers in East Lothian, how to labor and improve their grounds*, said to have been written by Lord Belhaven, about the time of the union, and reprinted in 1723, is the next work on the husbandry of Scotland. In this we have a deplorable picture of the state of agriculture, in what is now the most highly improved county in Scotland. His lordship begins with a very high encomium on his own performance. "I dare be bold to say, there never was such a good, easy method of husbandry as this, so succinct, extensive, and methodical in all its parts, published before." And he bespeaks the favor of those to whom he addresses himself, by adding, "neither shall I affright you with hedging, ditching, marling, chalking, paring and burning, draining, watering, and such like, which are all very good improvements indeed, and very agreeable with the soil and situation of East Lothian; but I know ye cannot bear as yet such a crowd of improvements, this being only intended to initiate you in the true method and principles of husbandry." The farm lands in East Lothian, as in other districts, were divided into *infield* and *outfield*, the former of which got all the dung. "The *infield*, where wheat is sown, is generally divided by the tenant into four divisions or breaks, as they call them, viz. one of wheat, one of barley, one of peas, and one of oats; so that the wheat is sowed after the pease, the barley after the wheat, and the oats after the barley. The *outfield* land is ordinarily made use of promiscuously for feeding their cows, horses, sheep, and oxen: it is also dunged by their sheep, who lay in earthen folds; and sometimes, when they have much of it, they fauch or fallow part of it yearly." Under this management, the produce seems to have been three times the seed; "and yet," says his lordship, "if in East Lothian they did not get a higher stubble than in other places of the kingdom, their grounds would be in a much worse condition than at present they are, though bad enough. A good crop of corn makes a good stubble, and a good stubble is the equalled mucking that is." Among the advantages of enclosures, he observes, "you will gain much more labor from your servants, a great part of whose time was taken up in gathering thistles, and other garbage, for their horses to feed upon in their stables; and thereby the great trampling and pulling up, and other destruction of the corns, while they are yet tender, will be prevented." Potatoes and turnips are recommended to be sown in the yard (kitchen-garden). Clover does not seem to have been known. Rents were paid in corn; and, for the largest farm, which he thinks should employ no more than two ploughs, the rent was "about six chalders of victual, when the ground is very good, and four in that which is not so good. But I am most fully convinced, they should take long leases or tacks, that they may not be straitened with time in the improvement of their rooms (farms); and this is profitable both for master and tenant."

784. Maxwell's *Select Transactions of the Society of Improvers of the knowledge of Agriculture in Scotland*, was published in 1743, (see 775.) and his *Practical Husbandman*, in 1757, including an *Essay on the Husbandry of Scotland*. In the latter he lays it down as a rule, that it is bad husbandry to take two crops of grain successively, which marks a considerable progress in the knowledge of modern culture;

though he adds, that in Scotland, the best husbandmen after a fallow take a crop of wheat; after the wheat, pease, then barley, and then oats; and after that they fallow again. The want of enclosures was still a matter of complaint. The ground continued to be cropped so long as it produced two seeds for one; the best farmers were contented with four seeds for one, which was more than the general produce.

785. In 1765, a treatise on agriculture was published by the Rev. Adam Dickson, minister of Dunse, in Berwickshire, which is decidedly the best work on tillage which has appeared in the English language, and was and still is held in universal esteem among the practical farmers of Scotland.

786. In 1777, Lord Kaimes published *The Gentleman Farmer*, being an attempt to improve agriculture by subjecting it to the test of rational principles. His lordship was a native of Berwickshire; and had been accustomed to farm in that country for several years, and afterwards at Blair Drummond, near Stirling. This work was in part a compilation and in part the result of his observation; and was of essential service to the cause of agriculture in Scotland.

787. In 1778, appeared *Wight's Present State of Husbandry in Scotland*. This is a valuable work; but the volumes not appearing but at intervals of some years, it was of less benefit than might have been expected.

788. In 1783, Dr. Anderson published his *Essays relating to agriculture and rural affairs*: a work of science and ingenuity, which did much good both in Scotland and England.

789. In 1800 appeared *The Farmer's Magazine*; a quarterly work, exclusively devoted to agriculture and rural affairs; and which has done more to enlighten both the proprietary and tenantry of Scotland than any other book which has appeared. It was at first conducted jointly by Robert Brown, farmer of Markle; and Robert Somerville, M. D. of Haddington. Afterwards, on Dr. Somerville's death, by Brown alone; and subsequently, on the latter gentleman's declining it, by Cleghorn, W. S., one of the most scientific agriculturists of Scotland. The frequent recurrence that will be made to *The Farmer's Magazine* in the course of this work, will shew the high value which we set on it. *The Husbandry of Scotland* is the next work deserving of notice in this sketch of Scottish authors, published by Sir John Sinclair in 1810; and which may very properly complete the series, as it fulfils in an able and complete manner what the title possesses.

790. *The rapid progress of agriculture in Britain* is shown by nothing more clearly than the great number of societies that have been lately formed; one or more in almost every county, for the diffusion of knowledge, and the encouragement of correct operations, and beneficial discoveries. Among these, the *Bath and West of England Society*, established in 1777, and the *Highland Society of Scotland*, in 1784, hold a conspicuous rank, and the establishment of the Board of Agriculture, in 1793, ought to form a new era in the history of the agriculture and rural economy of Britain.

791. A professorship of agriculture was established in the university of Edinburgh, in 1790, and the professor, Dr. Andrew Coventry, is well known as a man of superior qualifications for fulfilling its duties.

792. Professorships of agriculture, and even of horticulture, or rather of culture in general, are said to be partly provided for, and partly in contemplation, both in Oxford and Cambridge.

793. *The reports of the different counties*, many of them surveyed a second time, and now reprinted, according to an uniform plan, have been followed by the *General Report of the Agricultural State and Political Circumstances of Scotland*; and a similar work for England was understood to be in the contemplation of the board. But the continuation of that institution was deemed unnecessary by parliament; and its annual vote for its support being withdrawn, it ceased to exist in 1819.

794. *The Code of Agriculture*, published in 1819, by Sir John Sinclair, may be considered as giving a succinct view of the most improved practices of British husbandry as actually practised by professional farmers. It is a work which has already been translated into several foreign languages, and passed through more than one edition in this country.

### SUBJECT. 3. *Of the Rise, Progress, and present State of Agriculture in Ireland.*

795. *Of the agriculture of Ireland* very little is known up to a recent period. With a soil singularly prolific in pasture, and rather humid for the easy management of grain, it is probable that sheep and cattle would be the chief rural products for many centuries. In the twelfth century and earlier, various religious establishments were founded, and then it is most probable tillage on something like the Roman mode of culture would be introduced. The monks, says O'Connor, fixed their habitations in deserts which they cultivated with their own hands, and rendered them the most delightful spots in the kingdom.

796. *During the thirteenth, fourteenth, and fifteenth centuries*, the English were obliged to suppress the numerous rebellions of their Irish subjects by war, and the forfeited estates



of the rebels would in part be divided among the troops. This might end in introducing some agricultural improvements; but there is no evidence that such was effected before the time of Elizabeth, when the enormous demesnes of the Earl of Desmond were forfeited, and divided amongst a number of English undertakers, as they were called, who entered into a stipulation to plant a certain number of English families on their estates, in proportion to the number of acres. Among others who received portions were, Sir Walter Raleigh, and Spenser, the poet. The former is said to have then introduced the potatoe.

797. *The reign of James I.* was one of comparative tranquillity for Ireland: the power of the judges, and of the English government, was extensively fixed; the Irish laws and customs were abolished, and the English laws were established in all cases without exception, through the whole island. Numerous colonies were also sent from England and Scotland, especially the latter, to occupy the forfeited estates; and seven northern counties were wholly allotted to undertakers. This was called the "plantation of Ulster," and was attended by the introduction of an improved agriculture, and by the linen manufacture, which is still carried on by the descendants of the first colonists in the same counties.

798. *The city of London participated in this distribution of land*, the corporation having accepted of large grants in the county of Derry. They engaged to expend 20,000*l.* on the plantation; to build the cities of Derry and Colerain, and at the same time stipulated for such privileges as might make their settlement convenient and respectable. Under a pretence of protecting this infant settlement, or perhaps with a view of raising money, the king instituted the order of Irish baronets, or knights of Ulster; from each of whom, as was done in Scotland with respect to the knights of Nova Scotia, he exacted a certain sum, as the price of the dignity conferred. (*Wakefield.*)

799. *Of the husbandry of Londonderry*, a curious account was published about a century ago, by the archbishop of Dublin. He states that there was little wheat grown, and that of very inferior quality; the soil being considered as unsuitable to its production. Potatoes remained three or four years in the ground, reproducing a crop, which at the best was a very deficient one. Lime was procured by burning sea shells. The application of them in an unburnt state arose from accident. A poor curate, destitute of the means for burning the sea shells which he had collected, more with a view to remove an evidence of his poverty, than in any hope of benefit, spread them on his ground. The success which attended the experiment occasioned surprise, and ensured a rapid and general adoption of the practice. (*Wakefield.*) The improvements made since the period of which the Archbishop treats, Curwen remarks, are undoubtedly very considerable: and whilst we smile at the very subordinate state of agriculture at that time, may we not on reasonable ground expect that equal progress will at least be made in this century as in the last? (*Letters on Ireland*, vol. ii. p. 246.)

800. *A considerable impulse was given to the agriculture of Ireland after the rebellion of 1641*, which was quelled by Cromwell, as commander of the parliamentary army in 1652. Most of the officers of this army were yeomen, or the sons of English country gentlemen; and they took pleasure in instructing the natives in the agricultural practices to which they were accustomed at home. Afterwards, when Cromwell assumed the protectorship, he made numerous grants to his soldiers, many of whom settled in Ireland; and their descendants have become men of consideration in the country. Happily these grants were confirmed at the restoration. Some account of the state of culture in that country at this time, and of the improvements which it was deemed desirable to introduce, will be found in Blythe's *Improver Improved*. Blythe was a colonel in the parliamentary army.

801. *The establishment of the Dublin Society in 1749*, gave the next stimulus to agriculture and general industry in Ireland. The origin of the Dublin Society may be dated from 1731, when a number of gentlemen, at the head of whom was Prior of Rathdowney, Queen's county, associated themselves together for the purpose of improving the agriculture and husbandry of their country. In 1749, Prior, through the interest of the then lord lieutenant, procured a grant of 10,000*l.* per annum, for the better promotion of its views. Miss Plumtree considers this the first association ever formed in the British dominions expressly for such purposes; but the Edinburgh Agricultural Society, as we have seen (775.), was founded in 1723.

802. *Arthur Young's Tour in Ireland* was published in 1780, and probably did more good than even the Dublin Society. In this work he pointed out the folly of the bounty on the inland carriage of corn. His recommendation on this subject was adopted; and according to Wakefield, "from that hour may be dated the commencement of extended tillage in Ireland." (*Wakefield's Statistical Account, and Curwen's Letters.*)

803. *The present state of the agriculture of Ireland* is given with great clearness and ability in the supplement to the *Encyclopedia Britannica*; and from that source we have selected the following condensed account:—

804. *The climate of Ireland* is considerably more mild than that of England, and the southern and western part of the island greatly more so than the northern. The difference in this respect, indeed, is greater than can be explained by the difference of latitude; and is probably owing to the immediate vicinity of the Western ocean. On the mountains of Kerry, and in Bantry Bay, the arbutus and some other shrubs grow in great luxuriance, which are not to be met with again till the traveller reaches the Alps of Italy. The snow in these parts of the island seldom lies for any time, and frost hardly ever continues beyond a few days, and while it lasts it is by no means intense. The mildness and humidity of the atmosphere produce a luxuriance and rapidity of growth in vegetation, to which no other part of the empire can afford any parallel; and this appears in the most remarkable manner in the ivy and other evergreens, with which the kingdom abounds. These are not only much more plentiful, but far more luxuriant, and of much quicker growth, than in the most favored parts of Great Britain. To those who are accustomed to the dry weather of this island, the continued rains of the south and west of Ireland are extremely disagreeable: but it is to this peculiarity in their climate, that the Irish have to attribute the richness of their pasturage, an advantage which, coupled with the remarkable dryness and friability of the soil, points, in an unequivocal manner, to a rotation of crops, in which grazing should occupy a principal place.

805. *The territorial surface of Ireland* affords a pleasing variety, consisting in some parts of rich and fertile plains, in others of little hills and acclivities which succeed one another in frequent succession. The most elevated ground is to be found in the bog of Allan. Its height above the sea does not exceed 270 feet, yet, from this ridge, the waters of the river run to the different seas. This elevated ground is connected with the principal mountains of Ireland, diverging in the north from the hills of Tyrone, and leading in the south to those of Sleeve Bloom and the Galtees. The chains of mountains are neither numerous nor considerable; the most remarkable are, the Kerry mountains, those of Wicklow, the Sleeve Bloom chain between the King's and Queen's county, and the mountains of Mourne, in the south of the province of Ulster.

806. *The soil of Ireland* is, generally speaking, a fertile loam, with a rocky substratum; although there are many exceptions to this description, and many varieties. Generally speaking, it is rather shallow; to which cause the frequent appearance of rocks near the surface, or at no considerable depth, is to be attributed. It possesses a much greater proportion of fertile land, in proportion to its extent, than either England or Scotland. Not only is the island blessed with this extent of cultivatable ground, but it is almost all of such a quality as to yield luxuriant crops, with little or no cultivation. Sand does not exist except on the sea shore. Tenacious clay is unknown, at least near the surface. Great part of the land of Ireland throws up a luxuriant herbage, without any depth of soil, or any skill on the part of the husbandman. The county of Meath, in particular, is distinguished by the richness and fertility of its soil; and, in Limerick and Tipperary, there is a dark, friable sandy loam, which, if preserved in a clean state, will yield crops of corn several years in succession. It is equally well adapted for grazing as for arable crops, and seldom experiences either a winter too wet, or a summer too dry. The vales in many of the bleakest parts of the kingdom, as Donegal and Tyrone, are remarkable for their richness of soil and luxuriance of vegetation, which may be often accounted for by the deposition of the calcareous soil, washed down by the rains of winter, which spreads the richest manure over the soil below, without subjecting the farmer to any labor. (*Wakefield*, i. 79, 80.)

807. *The bogs, or peat mosses, of Ireland*, form a remarkable feature of the country, and have been proved by the parliamentary commissioners to be of great extent. They estimate the whole bogs of the kingdom at 2,330,000 acres, English. These bogs, for the most part, lie together. In form, they resemble a great broad belt, drawn across the centre of Ireland, with its narrowest end nearest to the capital, and gradually extending in breadth as it approaches the Western Ocean. The bog of Allan is not one contiguous morass, but this name is indiscriminately applied to a great number of bogs, detached from each other, and often divided by ridges of dry country. These bogs are not, in general, level, but most commonly of an uneven surface, swelling into hills, and divided by vallies, which afford the greatest facility to their being drained and improved. In many places, particularly in the district of Allan, the rivulets which these inequalities of surface produce, have worn their channels through the substance of the bog down to the clay, or limestone gravel beneath; dividing the bog into distinct masses, and presenting, in themselves, the most proper situations for the main drains, and which, with the assistance of art, may be rendered effectual for that purpose.

808. *The commissioners employed by government to report on the bogs of Ireland*, found three distinct growths of timber immersed below three distinct strata of bog. The timber was perfectly sound, though deprived of its bark, which has communicated its antiputrescent quality to the water, and of course has preserved every thing imbedded in the mass; though, as Miss Plumtree remarks, without "any thing like a process of tanning ever taking place." The bogs of Ireland are never on low ground, and have therefore evidently originated from the decay of woody tracts. (*Plumtree's Residence in Ireland*.)

809. *Landed property in Ireland* is more generally in large estates of some thousands of acres, than in small ones; but in its occupation it is subdivided in a degree far beyond any thing which occurs in any other part of the empire. In some counties, as Mayo for example, there are upwards of 15,000 freeholders on properties of not more than 40s. value, and who are perhaps not worth 10*l.* each. These are, for the most part, tenants of the great proprietors possessing a life interest in their little farm.

810. *In Ireland there are no manorial rights* separable from the right to the soil, as in England, nor legal poor rates, which are circumstances materially in favor of the former country. (*Wakefield*, i. 242.)

811. *Leases are generally of long endurance*; and three lives, or thirty-one years, is a common rate. The price of land varies in different parts of Ireland. In the neighborhood of Belfast, and thence to Armagh, it brings thirty years purchase; in the greatest part of the island, it does not exceed twenty; and, in the richest districts, it may often be bought for sixteen or eighteen. The exposure of landed estates to public sale takes place very seldom, which is, perhaps, one cause of their not bringing so high a price as they would otherwise do. (*Wakefield*.)

812. *Farming in Ireland* is, generally speaking, in a very backward state. With a few exceptions, such as the county of Meath, and some other well-cultivated districts, the farmers are destitute of capital, and labor small crofts, which they hold of middlemen, interposed between them and the landlord. The fact that the landlord never, in Ireland, lays out any thing upon repairs or buildings, coupled with the general inability of the farmer to do either in a substantial manner, is very significant as to the state of agriculture. (*Tighe's Survey of Kilkenny*, 412.; *Wakefield*, i. 244.) But the worst features of the rural economy of this land are the entire want of capital in the farmers, and the complete indifference of the landlord to the character, wealth, or industry of his tenant. "Capital," says Wakefield, "is considered of so little importance in Ireland, that advertisements constantly appear in the newspapers, in which it is stated, that the preference will certainly be given to the highest bidder. Bargains are constantly made with a beggar, as a new tenant, who, offering more rent, invariably turns out the old one, however industrious. Even if the unfortunate wretch has a little ready cash to begin with, it only serves, in ninety nine cases out of one hundred, as a temptation to the landlord, who, when the fact becomes known to him, finds means to obtain it under the name of a fine for possession." (*Vol. i. p. 587.*) Regard to present gain, without the least attention to the future, constitutes the principal object of the Irish landlord. (*Ibid.* i. 304.)

813. *The rent of land in Ireland* from these causes, coupled with the excessive competition of the peasantry for small farms, as their only means of subsistence, has risen to a great height. (*Townsend's Cork*, 218.; *Wakefield*, i. 582.)

814. *Ireland is divided, by Wakefield, into nine agricultural districts*, in each of which the mode of culture is somewhat different from what it is in the others.

815. *The first district* comprehends the flat parts of Antrim; the eastern side of Tyrone, Down, Armagh, Monaghan, and Cavan. Throughout this district, the farms are extremely small, and the land is generally dug with the spade. Potatoes, flax, and oats, are the crops usually cultivated, and these are grown till the land is exhausted, and suffered to "lie at rest," as they term it, till its strength is recruited by the cow, the goat, two or three sheep, and the poultry lying upon it, for some years. The ploughs used in this district are of the rudest structure, and perform their work in the most slovenly manner. Three or four neighbors unite their strength to each plough, every one bringing his horse, his bullock, or his cow. All the other operations of agriculture are performed in an equally slovenly manner. The little wheat that is raised is "lashed," as they call it; that is, the grain is knocked out by striking the sheaf across a beam placed above a cloth: it is, however, afterwards threshed with a flail. This operation

119



of threshing usually takes place in the highway, and it is dressed by letting it fall from a kind of sieve, which, during a pretty strong wind, is held breast-high by a woman. Many cottars in this district have a cabin (*fig. 119.*) with no land attached to it. They hire an acre or two, for grass or potatoe land, from some cottar in their vicinity. The custom of hiring labourers is unknown. The neighbours all assist each other in their more considerable occupations, such as sowing, and reaping. The dwellings here are miserably small; often too small to contain the numerous families that issue from their doors. Land is every where divided into the 'most minute portions. (*Wakefield*, i. 363.; *Dubourdieu's Down*, 39.)

816. *Under the second district* may be comprised the northern part of Antrim, Londonderry, the north and west of Tyrone, and the whole of Donegal. Agriculture here is in a worse state than in the pre-

ceding district. There is no clover, and hardly any wheat. Clover is unknown, and the only mill for the preparation of grain is in Derry. (*Ibid.* i. 372.)

817. *The third district* comprehends the northern parts of Fermanagh. Here the farms are much larger than in the former, and the agricultural system pursued far superior. They plant potatoes on a lea, twice reversing the lands; and the course is flax, oats, and weeds. Some wheat is grown, but oats is still the prevalent crop. In the neighborhood of Enniskillen, the farmers are so rich as to be able to eat butcher meat daily, and drink smuggled wine. (*Wakefield*, i. 379.)

818. *The fourth district* comprehends Sligo, Mayo, Galway, Clare, and parts of Roscommon, and Longford. In some parts of this district the spade culture is pursued; but, in general, the land is cultivated by a plough drawn by four horses abreast. In Roscommon, the old custom of yoking the horses by the tail is still continued, although, so early as 1634, an act of parliament was passed against this absurd practice. (*Life of the Duke of Ormond*, i. 79.) Oats are chiefly raised in this district, and, along the coast, barley is cultivated. A large portion of the rent depends on the illegal distilleries, and much of the district is let on lease to several persons jointly, according to the village system. (*Ibid.* i. 381.)

819. *In the fifth district*, which comprehends Limerick, Kerry, the south side and northern part of Cork, and the county of Waterford, cultivation is in a very rude state; little corn is grown here, with the exception of the southern part of Cork. Land is extremely divided, and the farms very small. The greater part is a grazing country. (*Ibid.* i. 387.)

820. *The sixth district* includes the southern parts of Cork. The spade culture is here almost universal, and the farms unusually small. Hogs constitute the main support of the poor. (*Townsend's Cork*, 194.)

821. *The seventh district* includes part of Tipperary, with Queen's county and King's county. The best farming in Ireland is observable in this district; a systematic course of husbandry being pursued, by which the land is kept in good heart. Oxen and horses are used in the plough, and hedgerows and good wheat fallows are to be seen. Near Roseria the cultivation of turnips is followed, and they succeed well. Ninety acres is considered a large farm. Leases are generally for three lives. (*Wakefield*, i. 398.)

822. *The eighth district* comprises Wexford and a part of Wicklow. Beans are here sometimes introduced into cultivation, but they are sown broadcast, and never hoed. The mode of ploughing is very awkward; one man holds the plough, another leads the horse, and a third sits on it to keep it down. Notwithstanding this rude culture, however, the rents are enormous, owing to the demand for land created by an excessive population, who if they had not a portion of land to grow potatoes (getting no employment) could not live. (*Ibid.* i. 407.)

823. *The ninth district* comprehends the northern part of Kilkenny, Kildare, the cultivated parts of Westmeath, Meath, and Louth. Wheat here enters into the system of culture, but the preparatory fallows are very bad. Clover has been introduced into the district, but under the bad system of sowing it upon land exhausted, and covered by weeds. Farms are large, and the mode of culture similar to what is pursued in England, though the details are executed in a much more slovenly manner. (*Ibid.* i. 413.)

824. *The agricultural implements and operations* used in Ireland are all of the rudest construction. The plough, the spade, the flail, the car, all equally partake of imperfections and defects. The fallows are not well attended to; three ploughings are usually deemed sufficient, and, from the imperfection of the plough, the ground at the end is generally full of weeds. Trenching land is very general; they form it into beds, and shovel out a deep trench between them, throwing up the earth. The expense of this operation is about eight shillings an acre. Wheat, as will be seen from the preceding details, is not by any means generally cultivated. It is unknown in Monaghan, Tyrone, Derry, Donegal, Sligo, Mayo, Leitrim, and Cavan, though it is grown to a considerable extent in Kilkenny, Carlow, Dublin, Meath, Louth, and parts of Limerick, Tipperary, Clare, and Cork. It is generally sown after potatoes or fallow. The Irish wheat is, for the most part, coarse and of inferior quality, and does not yield so much saccharine matter by twenty per cent. as the English. (*Wakefield*, i. 429. 442.)

825. *Barley is more generally cultivated in Ireland than wheat*, and it is generally sown after potatoes. Oats, however, constitute the species of grain most extensively raised; it is calculated, that throughout the whole kingdom there are ten acres of oats sown for one of any other species of corn. The Irish oats, however, are decidedly inferior to the English.

826. *The potatoes of Ireland* have long been celebrated, both on account of their quantity and excellent qualities: they are cultivated on every species of soil, either in drills or lazy beds. Potatoe land lets from six pounds six shillings to ten pounds ten shillings per acre; and the expense of culture, including rent, varies from thirteen pounds to sixteen pounds per acre. The produce is from eight hundred stone to one thousand stone the acre, at twenty-one pounds to the stone; that is, from sixteen thousand eight hundred to twenty-one thousand pounds. (*Ibid.* i. 450.)

827. *The indigenous grasses of Ireland* are not of any peculiar excellence. Notwithstanding all that has been said of the forin grass, its excellence and utility may be called in question. Their hay is seldom from sown grasses, generally consisting of the spontaneous produce of the soil. Clover is almost unknown. Newenham calculates that there are not five thousand acres under this crop in the whole island. (*Newenham*, 314.; *Wakefield*, i. 467.)

828. *There are few live hedges in Ireland*; in the level stone districts, stone walls, and in other places turf banks, are the usual fences.

829. *The dairy is the most extensive and the best managed part of Irish husbandry.* Kerry, Cork, Waterford, Carlow, Meath, West Meath, Longford, and Fermanagh, as well as the mountains of Leitrim and Sligo, are principally occupied by dairy farms. Butter is the chief produce. The average number of cows on a dairy farm is thirty or forty; three acres of land, of middling quality, are deemed necessary for the subsistence of each cow. The average produce of a cow is eight quarts in twenty-four hours in summer, and five in winter; four good milkers will yield half a cwt. of butter in a

week. The best butter is made in Carlow; the worst in Limerick and Meath. Generally speaking, the Irish are very clean in making this article; and it is exported to England, the East and West Indies, and Portugal. (*Wakefield*, i. 325., et seq.) The art of salting butter, Chaptal observes, is better known in Ireland than in any other country. (*Chimie appliqué à l'agriculture*.) The grazing of Ireland is not, as in England, a part of the regular rotation of crops, but is carried on in a country exclusively devoted to the breeding of cattle, like the highlands of Scotland. Great tracts of the country also are devoted to the grazing of sheep. Roscommon, Galway, Clare, Limerick, and Tipperary are the chief breeding counties for sheep; and Galway, Clare, Roscommon, Tipperary, and Meath, are the places where they are fattened. The sheep are of the long-wooled kind, and very large: they are never kept in sheep-folds, and hardly ever fed on turnips; which is chiefly owing to the very limited demand for mutton among the labouring people. (*Ibid.* i. 341.)

830. *The depressed state of the agriculture of Ireland* is considered as proceeding from the depressed state of the people. The main cause of their sufferings is traced by most writers (*Young*, *Dewar*, *Newenham*, *Wakefield*, *Curwen*, &c.) to the redundancy of population. In 1791, the population of the whole kingdom amounted to 4,200,000 persons, and it increases at the rate of one forty-sixth part per annum; or, in other words, it doubles itself every forty-six years. As might be expected in a country where the increase in the number of mankind has so far outstripped the progress of its wealth, and the increase of its industry, the condition of the people is in every department marked by extreme indigence. (*Dewar*, 91; *Young*, ii. 123.) The houses in which they dwell, the furniture in their interior, their clothing, food, and general way of life, all equally indicate the poverty of the country. The dress of the people is so wretched, that, to a person who has not visited the country, it is almost inconceivable. The Irish poor, indeed, have no conception of the comforts of life; and if they felt their full value, they could not afford them, for though necessaries are cheap, conveniences of all sorts are very dear.

831. *But while the Irish poor are in general destitute of all the accommodations, they hardly ever, except in years of extraordinary distress, know what it is to want the absolute necessaries of life.* The unsparing meal of potatoes, at which the beggar, the pig, the dog, the poultry, and the children, seem equally welcome; seldom fails the Irish laborer.

832. *Hence the laziness of the lower Irish.* Limited as their wants are to the mere support of animal life, they do not engage in labor with that persevering industry which artificial desires inspire; and the mode in which they are often paid, that is, the giving them a piece of potatoe land by the year, at once furnishes the means of subsistence, and takes away every stimulus to farther exertion. The farm-servants of the English or Scotch farmers, who carry on agriculture upon the improved system, are constantly employed in some species of labor; but after the potatoes of the Irish cottar are planted, there is hardly any thing to be done about his little croft till the season of digging arrives. During a great portion of the year he is doomed to idleness, and the habits he acquires during the long periods of almost total inaction, are too strong to be overcome when he is transferred to a more regular occupation. Such is the condition of the laboring classes.

833. *Ireland exhibits an assemblage of the most contradictory circumstances.* It is a country in which, under the most distressing circumstances, population has advanced with the most rapid pace, in which cultivation has advanced without wealth, and education without diffusing knowledge; where the peasantry are more depressed, and yet can obtain subsistence with greater facility, than in any other country of Europe. Their miserable condition will not appear surprising when the numerous oppressions to which they are subject are taken into consideration.

834. *In the foremost rank of their many grievances, the general prevalence of middlemen must be placed.* It is difficult to estimate the extent of the misery which the system of letting and subletting land has brought upon the Irish cultivators. Middlemen have, in every country, been the inseparable attendants of *absent* proprietors: and in such a country as Ireland, where there are numbers of disaffected persons in every quarter, the vigilant eye of a superior inspector is more particularly required.

835. *The system of under-letting lands often proves a great evil in Ireland.* By the law of England, the landlord is entitled to distrain for payment of rent, not only the stocking which belongs to his immediate tenant, but the crop or stocking of a subtenant; on the principle, that whatever grows on the soil ought to be a security to the landlord for his rent; and in Scotland the same rule holds where the landlord has not authorized the subtenant; but if he has, the subtenant is free when he has paid to the principal tenant. There is little hardship in such a rule in England, where the practice of subletting is, generally speaking, rare; but when applied to Ireland, where middlemen are universal, it becomes the source of infinite injustice; for the cultivator being liable to have his crop and stocking distrained on account of the tenant from whom he holds, and there being often many tenants interposed between him and the landlord, he is thus perpetually liable to be distrained for arrears not his own. The tenant, in a word, can never be secure, though he has faithfully paid his rent to his immediate superior; because he is still liable to have every thing which he has in the world swept off by an execution for arrears due by any of the many lease-

holders who may be interposed between him and the landlord. It is obvious that such a system must prevent the growth of agricultural capital: this, joined to the exertions of the middlemen, has been the true cause of the universal prevalence of the cottage system, and the minute subdivision of farms.

836. *The tithes in Ireland* have long been collected with a severity of which hardly any European state furnishes an example. This has arisen from the wealth and influence of the clergy, joined to the destitute situation of their parishioners. They fall, by the law of that country, only on the tillage of land; the greater part of which is held by cottar tenants; and thus the rich are exempted from bearing their share of the burden.

837. *Another grievance*, though not so extensive, is the fine imposed upon a township, for having had the misfortune to have a seizure for illicit distillation made within its bounds.

838. *These evils have been attended with the usual depressing effects* of oppression. They have prevented the growth of any artificial wants, or any desire of bettering their condition among the mass of the people. Despised by their superiors, and oppressed by all to whom they might naturally have looked for protection, the Irish have felt only the natural instincts of their being. Among the presbyterians of the north, and in the vicinity of manufacturing towns, higher notions of comfort may have imposed some restraint on the principle of population; but the poor humiliated catholics, enjoying no respectability or consideration in society, have sought only the means of subsistence; and finding, without difficulty, potatoes, milk, and a hovel, have overspread the land with a wretched offspring.

839. *To these causes* of a redundant population, of which the government of the country is, directly or indirectly, the source, are to be added others of a different kind.

840. *The first, is the influence of the parish priests*, who encourage marriage, in order to increase their own emoluments, and the superstition of the people, who regard it as a religious duty.

841. *The second cause*, is the general ignorance of the people.

842. *On the influence of education* in restraining the tendency to early and imprudent marriage, it would be superfluous in this place to enlarge.

843. *Various other circumstances* have combined to multiply to a great degree the facilities of population, and to expand, in this country, beyond almost any other, the means of subsistence.

844. *The fertility of the country* may be mentioned as one of the most obvious of these circumstances. The soil of Ireland is in general so rich, that it will yield an alternate crop of wheat and potatoes for ever, without any very great labor, and with little manure. The introduction of the potatoe, and its singular adaptation to the soil and climate of Ireland, is another concurring cause. An acre of potatoes, according to Newenham, will yield four times as much nourishment as one of wheat. By thus expanding the means of human subsistence, the potatoe has greatly promoted the population of Ireland; but as the able writer, from whom we have selected the above remarks, observes, "unless the people are predisposed, from other causes, to press upon the means of subsistence, it has no tendency to augment their redundancy. Under the government and political institutions of the Irish, the population of the country would have been equally *redundant*, though much *smaller* than it now is, if they had lived on oats or wheaten bread. The introduction of the potatoe may be the cause why the population is now six in place of three millions: but it is not the cause why, during the whole period of this increase, the numbers of the people have been greater than, under existing circumstances, could be comfortably maintained." (*Sup. Encyc. Brit. art. Ireland.*)

## CHAP. VI.

### *Present State of Agriculture in Ultra European Countries.*

845. *In this department of our history* the reader will not expect more than a very slight outline; not only from our limited space and the comparative scarcity of materials, but because the subject is less interesting to general readers. We shall notice in succession the principal countries of Asia, Africa, Australasia, and America.

#### SECT. I. *Present State of Agriculture in Asia.*

846. *The agriculture of Asia* is of a very different character from that of Europe, owing chiefly to the great difference of climate, and partly to the difference in civilization. The culture of this division of the globe is chiefly of two kinds, water culture and pasturage. Very little can be done without artificial watering, excepting in the northern and mountainous parts, where the climate resembles that of Europe. Even the palm and other fruit trees are watered in some parts of Persia and Arabia, and

several fruit-trees are regularly irrigated in India. The grand bread corn of Asia is rice, a watered grain; and the most valuable fruits, those of the palm family; the most useful agricultural laborer is the ox, and his family are also the most valuable as pasturage animals.

SUBJECT. 1. *Present State of Agriculture in Asiatic Turkey.*

847. *Asiatic Turkey* extends from the Archipelago 1050 miles to Ararat in Persia on the east, and from the Euphrates 1100 miles to the Caucasian mountains on the north. It contains a number of provinces differing materially from each other in natural circumstances, and artificial culture; but, unfortunately for us, very little is known of their agriculture. In general, the Asiatic Turks are to be considered as a wandering and pastoral people, cultivating no more corn than what is sufficient for their own maintenance; and scarcely half civilized.

848. *The climate of Asia Minor* has been always considered as excellent. The heat of the summer is tempered by numerous chains of high mountains, some of which are covered constantly with snow. The aspect of Asiatic Turkey is mountainous, intermingled with spacious and beautiful plains, which afford pasture to the numerous flocks and herds of the Turkomans. The soil is various; but the chief agricultural products are wheat, barley, and doura (millet). It abounds also with grapes, olives, and dates. In Syria, the agriculture is deplorable, and the peasants are in a wretched condition, being sold, as in Poland, with the soil, and their constant fare being barley bread, onions, and water.

849. *The numerous mountains of Asiatic Turkey* are frequently clothed with immense forests of pines, oaks, beeches, elms, and other trees; and the southern shores of the Black Sea present many gloomy forests of great extent. The inhabitants are hence supplied with abundance of fuel, in defect of pit-coal, which has not been explored in any part of Asiatic Turkey. Sudden conflagrations arise from the heedless waste of the caravans, which, instead of cutting off a few branches, often set fire to a standing tree. The extensive provinces of Natolia, Syria, and Mesopotamia, have been little accessible to European curiosity, since their reduction under the Turkish yoke. In Pinkerton's *Geography* we have a catalogue of those plants and trees that have been found wild in the Asiatic part of the Ottoman territory. Several dyeing drugs and articles of the materia medica are imported from the Levant, among which are madder, and a variety called alizan, which grows about Smyrna, and affords a much finer red dye than the European kind; jalap, scammony, sebesten, the ricinus (*Ricinus communis*, fig. 120.), yielding by expression castor-oil, squirting cucumber, coloquintida, opium poppy, and spikenard. The best horses in Asiatic Turkey are of Arabian extract; but mules and asses are more generally used. The beef is scarce and bad, the mutton superior, and the kid a favorite repast. Other animals are the bear, tiger, hyæna, wild-boar, jackal, and dogs in great abundance. On the summits of Caucasus is found the ibex, or rock-goat; at Angora, singular goats and cats; the gazel, deer, and hares in great abundance are found in Asia Minor. The partridges are generally of the red-legged kind, larger than the European; fish is plentiful and excellent.

120



SUBJECT. 2. *Present State of Agriculture in Persia.*

850. *The climate of Persia* is various in different parts; depending less on difference of latitude than on the nature and elevation of the country, so that it is said to be the country of three climates. The northern provinces on the Caspian are comparatively cold and moist: in the centre of the kingdom, as Chardin observes, the winter begins in November, and continues till March, commonly severe, with ice and snow, the latter falling chiefly on the mountains, and remaining on those three days' journey west of Ispahan for eight months in the year. From March to May high winds are frequent; but from May to September the air is serene, refreshed by breezes in the night. The heat, however, is during this period excessive in the low countries, bordering on the India ocean and Persian gulf, in Chusistan, the deserts of Kerman, and also in some parts of the interior, particularly at Tehraun, the capital. From September to November the winds again prevail. In the centre and south the air is generally dry; thunder and lightning are uncommon, and a rainbow is seldom seen; earthquakes are almost unknown; but heat is often destructive in the spring. Near the Persian gulf the hot wind, called "samiel," sometimes suffocates the unwary traveller. The summers are, in general, very mild, after ascending the mountains. To the north of Shiraz the winters are severe, inasmuch, that in the vicinity of Tehraun and Tabreez, all communication is cut off for

several successive weeks between these cities and the adjoining villages. The climate, notwithstanding this sudden transition from heat to cold, is singularly healthy, with the exception of the provinces of Ghilan, and Mazanderam. The air is dry; the dews not insubrious. The atmosphere is always clear, and at night the planets shine with a degree of lustre unknown in Europe; and as it seldom rains, here are none of those damps or pestiferous exhalations so common in the woody parts of Hindustan.

851. *The surface of Persia* is distinguished by a deficiency of rivers and a multitude of mountains; its plains, where they occur, are generally desert. So that Persia may be divided into two parts by deserts and mountains; and this division, it is said, has generally influenced its history and destinies in all ages. It is every where open, and no where presents a thriving populous appearance. Even the cities and their environs have something of desolation and decay in their aspect, and many of them are actually ruined or neglected, of which Buschire and its territory (*fig. 121.*) is an example. The most fertile and thriving provinces are those on the north.

121



852. *The soil* may be regarded as unfertile, and, according to Chardin, not more than one-tenth part was cultivated in his time. The mountains of this country, which are for the most part rocky, without wood or plants, are interspersed with vallies, some of which are stony and sandy, and some consisting of a hard dry clay, which requires continual watering; and hence the Persian cultivator is much employed in irrigation. In general the soil of Persia is light and sandy in the south and east; hard and gravelly in the west, and rich and loamy on the borders of the Caspian sea.

853. *The landed property of Persia*, like that of other despotic countries, is considered as wholly the property of the sovereign; and held by the proprietors and occupiers on certain conditions of military service, and supplies of men and provisions in time of war.

854. *The agricultural products of Persia* are as various as the climate and soils. The wheat is excellent, and is the common grain used in bread making. Rice, which is in more universal use, is produced in great perfection in the northern provinces, which are well watered. Barley and millet are sown, but oats are little cultivated: in Armenia there is some rye. The vine is generally cultivated; but in the north-west countries they are obliged to bury the shoots to protect them from the frost. The silkworm is cultivated in most parts of the country; cotton and indigo are also grown, and no country in the world equals Persia in the number and excellence of its fruits.

855. *The date tree* is grown in plantations in the proportion of fifty females to two males. The natives begin to impregnate the females with the blossoms of the male in March and April, alleging, that their proximity is not sufficient to ensure the produce of fruit: this practice has been carried on among them from the earliest ages. (*Scot Waring's Persia*, chap. xxix.)

856. *The most esteemed of the cultivated fruits of Europe* are indigenous in Persia, and have probably been diffused from hence over the western world. These are the fig, the pomegranate, the mulberry, the almond, peach, and apricot. Orange-trees (*fig. 122.*) of an enormous size, are found in the sheltered recesses of the mountains and the deep, warm sand on the shore of the Caspian is peculiarly favorable to the culture of the citron (*fig. 123.*), and the leguminous

122





fruits. Apples, pears, cherries, walnuts, melons, besides the fruits already mentioned, are everywhere to be procured at very low prices; the quinces of Ispahan are the finest in the East; and no grape is more delicious than that of Shiraz. In the provinces bordering on the Caspian sea, and mount Caucasus, the air is perfumed with roses and other sweet-scented flowers. Among the vegetable productions we may enumerate cabbages, cucumbers, turnips, carrots, pease, and beans; and the potato, which has been lately introduced, thrives remarkably well. Poppies, from which an excellent opium is extracted, senna, rhubarb, saffron, and assafetida are produced in many parts of the kingdom. The vine grows here luxuriantly, and further to the south cotton and sugar are articles of common cultivation. Poplars, large and beautiful, and the weeping-willow, border the course of the streams, and the marshy tracts abound with the kind of rush that serves for the Persian matting.

Ornamental shrubs or herbaceous plants are little known; but the jasmine, the blue and scarlet anemone in the thickets, and the tulip and ranunculus in the pastures, are abundant and beautiful, and give an air of elegance to the country.

857. *The saline deserts of Persia* are for the most part destitute of trees, and support hardly any plants except those that are also found on the sea-shore. On the high mountains they are much the same as those observed on the alps of Switzerland and Italy. The plants on the hills and plains adjoining the Caspian are better known.

858. *The live stock of Persia* are the same as in European countries with some additions. According to Chardin, the Persian horses are the most beautiful in the East; but they yield in speed, and, as some say, in beauty also, to the Arabian; however, they are larger, more powerful, and all things considered, better calculated for cavalry than those of Arabia. There are several breeds of horses, but the most valuable is that called the Turkoram, which are so hardy that they have been known to travel nine hundred miles in eleven successive days. The Arabian blood has also been introduced into this country. Their usual food is chopped straw and barley; their bed is made of dung, dried and pulverised, and every morning regularly exposed to the sun. They are clothed with the greatest attention, according to the climate and season of the year; and during the warm weather kept in the stable during the day, and taken out at night.

859. *Mules* are also here in considerable request; and the ass resembles the European; but a breed of this animal has been brought from Arabia, of an excellent kind, the hair being smooth, the head high, and the motion spirited and agile. Although the mules are small, they are fairly proportioned, carry a great weight, and those that are intended for the saddle are taught a fine amble, which carries the rider at the rate of five or six miles an hour. The camel (*fig. 124.*) is also common; and the animals which are exported from Persia

124



to Turkey, have, as Chardin says, only one hunch, while those of India and Arabia have two. The Persian cattle in general resemble the European. Swine are scarce, except in the north-west provinces. The flocks of sheep, among which are those with large tails, are most numerous in the northern provinces of Erivan, or the Persian part of Armenia, and Balk. The few forests abound with deer and antelopes; and the mountains supply wild-goats, and probably the ibex, or rock goat. Hares are common. The ferocious animals are chiefly concealed in the forests, such as the bear and boar, the lion in the western parts, the leopard, and, as some say, the small or common tiger. Seals occur on the rocks of the Caspian. The hyæna and jackal belong to the southern provinces. The seas abound with fish of various descriptions; the Caspian affords sturgeon, and delicious carp. The most common river fish is the barbel. The same sorts of wild and tame fowl are common in Persia and in Europe, with the exception of the turkey, whose nature does not seem to be congenial to this climate. Pi-



geons are numerous, and partridges are large and excellent. The bool-beell, or oriental nightingale, enlivens the spring with his varied song. The Persians have been long accustomed to tame beasts of prey and even to hunt with lions, tigers, leopards, panthers, and ounces.

860. *The Persians hunt the quail in a curious manner (fig. 125);* they stick two poles in their girdle, upon which they place either their outer coat or a pair of trowsers, and these at a distance are intended to look like the horns of an animal; they then with a hand-net prowls about the fields, and the quail seeing a form more like a beast than a man, permits it to approach so near as to allow the hunter to throw his net over it: in this manner they catch these birds with astonishing rapidity.

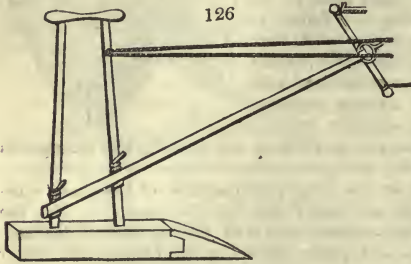

861. *Of the implements and operations of Persian agriculture little is known with precision.* The plough is said to be small, and drawn by lean cattle, so that it merely scratches the ground. The plough of Erzerum (fig. 126.), is a clumsy implement, on the share of which the driver stands, both for the sake of being carried along and of pressing down the wedge. After the plough and harrow the spade is used for forming the ground into squares, with ledges or little banks to retain the water. The

dung used is chiefly human, and that of pigeons, mingled with earth and preserved for two years, to diminish its heat.

862. *The dung of pigeons* is so highly prized in Persia that many pigeon-houses (fig. 127.) are erected at a distance from habitations for the sole purpose of collecting their manure. They are large round towers, rather broader at the bottom than at the top, and crowned by conical spiracles through which the pigeons descend.

Their interior resembles a honeycomb, forming thousands of holes for nests; and the outsides are painted and ornamented. The dung is applied almost entirely to the rearing of melons, a fruit indispensable to the natives of warm countries during the great heats of summer, and also the most rapidly raised in seasons of scarcity; and hence the reason that during the famine of Samaria a cab of dove's dung was sold for five pieces of silver. (2 Kings, vi. 25.) The Persians do not eat pigeons. (Morier's Second Journey, &c. 141.)

863. *No arable culture* is carried on in Persia without artificial watering; and various modes are adopted for raising the element from wells and rivers for this purpose. The Persian wheel is well known. The deficiency of rivers in Persia has obliged the natives to turn all their ingenuity to the discovery of springs, and to the bringing of their streams to the surface of the earth. To effect this, when a spring has been discovered, they dig a well until they meet with the water; and if they find that its quantity is sufficient to repay them for proceeding with the work, they dig a second well, so distant from the other as to allow a subterranean communication between both. They then ascertain the nearest line of communication with the level of the plain upon which the water is to be brought into use, and dig a succession of wells, with subterranean communications between the whole suite of them, until the water at length comes to the surface, when it is conducted by banked-up channels into the fields to be irrigated. The extent of country through which such fields are sometimes conducted is quite extraordinary. In making the wells (fig. 128.) a shaft is first dug, then a wooden handle is placed over it, from which is suspended a leathern bucket, which is filled with the excavated matter by a man below, and wound up by another above. Where the soil is against the mouth of the wells, they are secured by

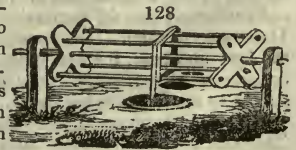

masonry. This mode of procuring water is common to the whole of Persia, and has the great defect of being easily destroyed by an enemy. (*Morier's Second Journey*, 164.)

864. *The forests of Persia are few, and chiefly in the mountains of Mazanderam and Ghilan, and those towards Kurdistan. The trees are several kinds of pines, the cedar and cypress, limes, oaks, acacias, and chestnuts; the sumach is also abundant, and used for tanning; manna is also procured from the fraxinus ornus. Very little fuel, and not much timber is used in Persia; in the castles and principal houses, arches are employed instead of timber floors.*

SUBJECT. 3. *Present State of Agriculture in Independent Tatar.*

865. *The extent of Independent Tatar* can hardly be considered as well defined; but Pinkerton measures it from the Caspian sea on the west to the mountains of Belus on the east, a space of 870 miles; and from th mountains of Gaur to the Russian boundaries on the north of the desert of Issim, a distance of 1500 miles. It is occupied by the Bucharian, Tungusian, Kirgusian, and other Tatar hordes, and is a celebrated and interesting country, as being the probable seat of the most ancient Persian kingdoms, and as having given birth to Zoroaster and other names eminent in oriental literature. Modern travellers represent the more civilized of this nation as indolent, but good-natured. They are easily recognised among other varieties of man (*fig. 129.*)

866. *The climate of this extensive country appears to be excellent, the heat even of the southern provinces being tempered by the high mountains capped with perpetual snow; and though situated in the parallel of Spain, Greece, and Asiatic Turkey, the proximity of the Siberian deserts and the lofty alps render the summer more temperate.*

867. *The surface of the country presents a great variety; and there are numerous rivers, hills, and mountains.*

868. *The soil near the rivers is very productive, so that the grass exceeds the height of a mau. In any other hands but those of the Tatars, this country might rival any European region.*

869. *All that is known of the tillage of the Tatars, is, that rice and other grains are cultivated near the towns; but that the great dependence of the people is upon their flocks and herds. Bucharia is the richest country, both in corn and cattle. There they have horses, camels, oxen, sheep, and goats, which some individuals reckon by thousands, and make large sales, especially of horses, to the Persians and Turks. They have also dromedaries, which furnish a considerable quantity of woolly hair, which they clip off periodically and sell to the Russians. The lambskins are celebrated, being damasked as it were by clothing the little animal in coarse linen; but the wool of the sheep is coarse, and only used in domestic consumption for felts and thick cloths. The steppes, which are of immense extent, supply them with objects of the chase, wolves, foxes, badgers, antelopes, ermines, weasels, marmots, &c. In the southern and eastern mountains are found wild sheep (*Ovis nussimon*), the ox of Thibet (*Bos grunniens*, *fig. 130.*), which seems to delight in snowy alps; with chamois, tigers, and wild asses. There seems throughout the whole of Tatar to be a deficiency of wood; and the botany of this immense region is as little known as its agriculture.*

129



130



SUBJECT. 4. *Present State of Agriculture in Arabia.*

870. *The extent of Arabia is somewhat greater than that of Independent Tatar. The climate is hot, but there is a regular rainy season, from the middle of June to the end of September, in some mountainous districts, and from November till February in others. The remaining months are perfectly dry; so that the year in Arabia consists only of two seasons, the dry and the rainy. In the plains, rain is sometimes unknown for a whole year. It sometimes freezes in the mountains, while the thermometer is at 86° in the plains, and hence at a small distance are found fruits and animals which might indicate remote countries.*

871. *The general surface presents a central desert of great extent, with a few fertile oases or isles, and some ridges of mountains, chiefly barren and unwooded. The flourishing provinces, are those situated on the shores of the Red and Persian seas, the interior of the country being sterile for want of rivers, lakes, and perennial streams. The soil is in general sandy, and in the deserts is blown about by the winds.*

872. *The agricultural products are wheat, maize, doura, or millet, barley, beans, lentiles,*

and rape, with the sugar-cane, tobacco, and cotton. Rice seems unknown in Yemen, and oats throughout Arabia: the horses being fed with barley, and the asses with beans. They also cultivate "uars," a plant which dyes yellow, and is exported in great quantities from Mocha to Oman; and "fua," used in dyeing red; likewise indigo. The wheat, in the environs of Maskat, yields little more than ten for one; and in the best cultivated districts of Yemen, fifty to one; but the durra sometimes much exceeds this ratio, yielding in the highlands 140, and in the Tehama, or plain, from 200 to 400. By their mode of sowing, and watering this grain, the inhabitants of Tehama reap three successive crops from the same field in the same year. The plough (*fig. 131.*) is simple, and the pick is used instead of the spade.

131

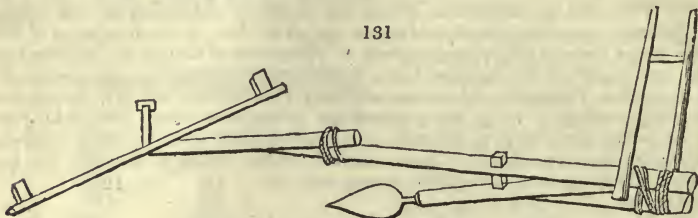

873. *The indigenous, or partially cultivated plants and trees* of Arabia are numerous, and several of them furnish important articles of commerce. The vegetables of the dry barren districts, exposed to the vertical sun, and refreshed merely by nightly dews, belong for the most part to the genera of aloe, mesembryanthemum, euphorbia, stapelia, and salsola. On the western side of the Arabian desert, numerous rivulets, descending into the Red Sea, diffuse verdure; and on the mountains from which they run vegetation is more abundant. Hither many Indian and Persian plants, distinguished for their beauty or use, have been transported in former ages, and are now found in a truly indigenous state: such is the case probably with the tamarind, the cotton tree (inferior to the Indian), the pomegranate, the banyan tree, or Indian fig, the sugar-cane, and many species of melons and gourds. Arabia Felix may peculiarly boast of two valuable trees, namely, the coffee (*Coffea Arabica*), found both cultivated and wild; and the amyris opobalsamum, which yields the balm of Mecca. Of the palms, Arabia possesses the date, the cocoa-nut, and the great fan-palm. It has also the sycamore fig, the plantain, the almond, apricot, peach, the papaw, the bead tree, the mimosa nilotica, and sensitiva, and the orange. Among its shrubs and herbaceous plants may be enumerated the ricinus, the liquorice, and the senna, used in medicine; and the balsam, globe, amaranth, the white lily, and the greater pancratium, distinguished for their beauty and fragrance.

874. *The live stock* of Arabia is what constitutes its principal riches, and the most valuable are those species of animals that require only succulent herbs for their nourishment. The cow here yields but little milk; and the flesh of the ox is insipid and juiceless. The wool and mutton of the sheep are coarse. The bezoar goat is found in the

132

mountains. The buffalo is unknown; but the camel and dromedary (*fig. 132.*) are both in use as beasts of burden. The civet cat, musk rat, and other mountain animals, are valuable in commerce. Pheasants, partridges, and common poultry, abound in Yemen; and there are numerous ferocious animals, birds of prey, and pestiferous insects.

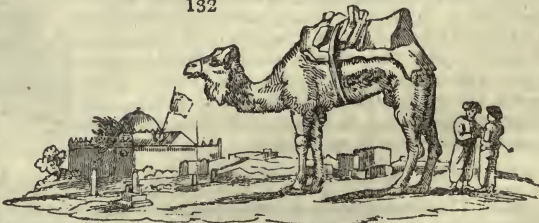

875. *But the horse* is of all the animals of Arabia the most valuable. This animal is said to be found wild in the extensive deserts on the north of Hadramant: this might have been the case in ancient times, unless it should be thought more probable, that the wild horse of Tatory has passed through Persia, and has been only perfected in Arabia. The horses here are distributed into two classes, viz. the *kadischi*, or common kind, whose genealogy has not been preserved, and the *kochlani*, or noble horses, whose breed has been ascertained for 2000 years, proceeding, as their fables assert, from the stud of Solomon. They are reared by the Bedouins, in the northern deserts between Bassora, Merdin, and the frontiers of Syria; and though they are neither large nor beautiful, their race and hereditary qualities being the only objects of estimation, the preservation of their breed is carefully and authentically witnessed; and the offspring of a Kochlain stallion with an

ignoble race is reputed *kadischi*. These will bear the greatest fatigues, and pass whole days without food, living, according to the Arabian metaphor, on air. They are said to rush on a foe with impetuosity; and it is asserted that some of them, when wounded in battle, will withdraw to a spot where their master may be secure; and if he fall, they will neigh for assistance; accordingly, their value is derived from their singular agility, an extreme docility, and an uncommon attachment to their master. The Arabian steeds are sometimes bought at excessive rates by the English at Mocha. The duke of Newcastle asserts, that the ordinary price of an Arabian horse is 1000*l.*, 2000*l.*, or even 3000*l.*; and that the Arabs are as careful in preserving the genealogy of their horses, as princes in recording that of their families: the grooms are very exact in registering the names of the sires and dams of these animals; and some of them are of very ancient date in this species of pedigree. It is affirmed that Arabian colts are brought up with camels' milk.

876. *Of the agricultural implements and operations of Arabia almost nothing is known.* Their plough, as we have seen (872.), is a poor implement, and instead of a spade they use the pick. The principal exertion of the husbandman's industry is to water the lands from the rivulets and wells, or by conducting the rains. Barley is reaped near Sana in the middle of July; but the season depends on the situation. At Maskat, wheat and barley are sown in December, and reaped in March; but doura is sown in August, and reaped in the end of November. The Arabians pull up their ripe corn by the roots; but the green corn and grass, as forage for their cattle, are cut with the sickle. In threshing their corn, they lay the sheaves down in a certain order, and then lead over them two oxen dragging a large stone.

#### SUBJECT. 5. *Present State of Agriculture in Hindustan.*

877. *The climate and seasons of this extensive region are considerably diversified by difference of latitude and local situation; nevertheless, through the wide regions of Hindustan there is some similarity of climate.* Although in Thibet the winter nearly corresponds with that of Switzerland and other parts of Europe, in the whole extent of Hindustan, except in Cashmere, there can hardly be said to be a vestige of winter, except the thick fogs of our November; and excessive rains, or excessive heats, form the chief varieties of the year.

878. *The surface of the country is much diversified; but there are no mountains of any very great height; the ghauts not being estimated at above three thousand feet.* The vast extent of Hindustan consists chiefly of large plains, fertilized by numerous rivers and streams, and interspersed with a few ranges of hills. The periodical rains and intense heats produce a luxuriance of vegetation almost unknown to any other country in the globe; and the variety and richness of the vegetable creation delight the eye of every spectator. Bengal is a low, flat country, like Lower Egypt, watered and fertilized by the Ganges, as the former country is by the Nile; and which, like the latter river, forms an immense delta, before it falls into the sea. The interior of the country is so flat, that water runs only at the rate of three miles an hour; and the ground rises from the sea towards the interior, at not more than four inches in a mile.

879. *The soil varies, but is in most places light and rich: that of Bengal is a stratum of black vegetable mould, rich and loamy; extending to the depth of six feet, and in some places fourteen, and even twenty feet; lying on a deep sand, and interspersed with shells and rotten wood, which indicate the land to have been overflowed, and to have been formed by materials deposited by the rivers. It is easily cultivated without manure, and bad harvests seldom occur. In this country they have two harvests; one in April, called the "little harvest," which consists of the smaller grains, as millet; and the second, called the "grand harvest," is only of rice.*

880. *Landed property in Hindustan, as in all the countries of Asia, is held to be the absolute right of the king. The Hindû laws declare the king to be the lord and proprietor of the soil. All proprietors, therefore, paid a quitrent, or military services to the king or rajah, excepting some few, to whom it would appear absolute grants were made. In general, the tenure was military; but some lands were appropriated to the church and to charitable purposes, and in many places commons are attached to villages as in Europe. Lands in Hindustan, and in Bengal more especially, are very much divided, and cultivated in small portions by the ryots, or peasants, who pay rent to subordinate proprietors, who hold of others who hold of the rajah. The actual cultivators have hardly any secure leases; they are allowed a certain portion of the crop for the maintenance of their families and their cattle; but they are not intrusted with the seed, which is furnished by the proprietor or superior holder. The ryot, or cultivator, is universally poor; his house, clothing, and implements of every kind, do not amount to the value of a pound sterling; and he is considered as a sort of appendage to the land, and sold along with it, like his cattle. So little attention is paid to any agreement made with him, that in a good season, Dr. Tennant informs us, the zemindar, or superior holder, raises his demands to a fourth more than the rent agreed on. Custom has rendered this evil so common that the miserable ryot has no more idea of obtaining redress from it*

than from the ravages of the elements. Since Bengal was conquered by the British, the government is, properly speaking, the proprietor of all the lands; and Tennant accordingly observes, that "nine tenths of all the rent of Bengal and the provinces constitute the revenue of the company; who are, in room of the Mogul emperor, the true proprietors of the soil." (*Recreations*, ii. 184.)

881. *The agricultural products of Hindustan are very various.* Rice, wheat, and maize are the common grains; but barley, pease, a species of tare or cytissus, called dohl, and millet, are also cultivated. Next to them the cotton plant and the sugar-cane are most extensively grown. To these may be added indigo, silk, hemp, poppy for opium, palma christi, sesamum, mustard, the cocoa-nut, which supplies a manufacture of cordage, and also a liquor called toddy; guavas, plantains, bananas, pomelos, limes, oranges, and a great variety of other fruits besides what are cultivated in gardens, where the settlers have all the vegetables of European horticulture. The potatoe has been introduced, and though it does not attain the same size as in Europe, is yet of good quality. It is not disliked by the natives, but cannot be brought to market at so low a price as rice.

882. *The sugar-cane* (*Saccharum officinarum*, fig. 133.) is cultivated in low grounds that may be flooded. The ground being cleaned and pulverized by one or two years fallow, is planted with cuttings of two or three buds, in rows of four feet apart and eighteen inches wide in the row: as they grow, each stool, consisting of three or more shoots, is tied to a bamboo reed, eight or ten feet long, the lower leaves of each cane being first carefully wrapt round it so as to cover every part, and prevent the sun from cracking it, or side shoots from breaking out. Watering and flooding in the dry season, and keeping open the surface drains during the periodical rains, are carefully attended to. Nine months from the time of planting the canes are ten feet high, and ready to cut. The process of sugar making, like all others in this country, is exceedingly simple: a stone mortar and wooden pestle turned by two small bullocks, expresses the juice, which is boiled in pots of earthenware, sunk in the ground, and heated by a flue which passes beneath and around them, and by which no heat is lost. The whole expense of growing and bringing to market does not require above a third of the time, and a tenth of the money, which it does in the West Indies.

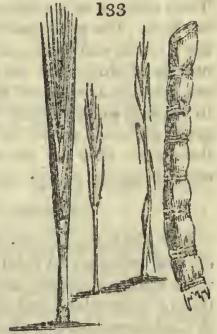

883. *The indigo* (*Indigofera tinctoria*, fig. 134.) is one of the most profitable articles of culture in Hindustan; because an immense extent of land is required to produce but a moderate bulk of the dye; because labor and land here are cheaper than any where else; and because the raising of the plant and its manufacture may be carried on without even the aid of a house. The first step in the culture of the plant is to render the ground, which should be friable and rich, perfectly free from weeds, and dry if naturally moist. The seeds are then sown in shallow drills about a foot apart. The rainy season must be chosen for sowing, otherwise if the seed is deposited in dry soil, it heats, corrupts, and is lost. The crop being kept clear of weeds, is fit for cutting in two or three months, and this may be repeated in rainy seasons every six weeks. The plants must not be allowed to come into flower, as the leaves in that case become dry and hard, and the indigo produced is of less value; nor must they be cut in dry weather, as they would not spring again. A crop generally lasts two years. Being cut, the herb is first steeped in a vat till it has become macerated and parted with its coloring matter; then the liquor is let off into another, in which it undergoes the peculiar process of beating to cause the fecula to separate from the water. This fecula is let off into a third vat, where it remains some time, and is then strained through cloth bags, and evaporated in shallow wooden boxes placed in the shade. Before it is perfectly dry it is cut in small pieces of an inch square; it is then packed in barrels, or sowed up in sacks for sale. Indigo was not extensively cultivated in India before the British settlements were formed there; its profits were at first so considerable, that as in similar cases its culture was carried too far, and the market glutted with the commodity. The indigo is one of the most precarious of oriental crops; being liable to be destroyed by hail storms, which do comparatively little injury to the sugar-cane and other plants.



884. *The mulberry* is cultivated in a different manner from what it is in Europe. It is raised from cuttings, eight or ten of which are planted together in one pit, and the pits are distributed over the field at the distance of two or three feet every way. These cuttings being well firmed at the lower ends, soon form stools about the height of a raspberry bush, and from these the leaves are gathered. The stools are cut over once a year to encourage the production of vigorous shoots from the roots.

885. *The poppy* (*Papaver somniferum*) is cultivated on the best soil, well manured. The land sometimes receives as many as fifteen stirrings, and the seed is then dropped into shallow drills about two feet apart. During the growth of the plants the soil is stirred, well watered, and sometimes top-dressed. In two months from the time of sowing, the capsules are ready for incision, which process goes on for two or three weeks, several horizontal cuts being made in the capsule one day, and the next the milky juice

which had oozed out, being congealed, is scraped off. This operation is generally repeated three times on each capsule; and then the capsules are collected for their seed. The raw juice is kneaded with water evaporated in the sun, mixed with a little poppy oil, and lastly, formed into cakes, and covered with leaves of poppy, and packed in chests with poppy husks and leaves.

886. *Tobacco* in Hindustan is cultivated in the same manner as in Europe; the soil must be rich and well pulverized; the plants transplanted, and the earth stirred during their growth; the main stems are broke off, and the leaves are dried by being suspended on beds of withered grass by means of ropes, and shaded from the sun and protected from nightly dews. The leaves afford a much weaker odour than those of the tobacco of Europe or America.

887. *The mustard, sesamum orientalis, flax, palma christi,* and some other plants are grown for their seeds, which are crushed for oil. The use of the flax as a clothing plant is not understood in India, hemp supplying its place. The mustard and sesamum are sown on the sand left by the overflowings of the rivers without any other preparation or culture than that of drawing a bush over the seeds to cover them. The palma christi is sown in patches three or four feet apart, grows to the size of a little tree, and is cut down with an axe when the seeds are to be gathered. The mill for bruising the seeds of these plants is simply a thick trunk of a tree hollowed into a mortar, in which is placed the pestle, turned by one or two oxen.

888. *Palm trees* of several species are in general cultivation in Hindustan. The most useful is the cocoa-nut tree (*Cocos nucifera*, fig. 135.) which grows almost perfectly straight to the height of forty or fifty feet; and is nearly one in diameter. It has no branches, but about a dozen leaves spring immediately from the top: these are about ten feet long, and nearly a yard in breadth towards the bottom. The leaves are employed to cover the houses of the natives; and to make mats either for sitting or lying upon. The leaf when reduced to fine fibres, is the material of which a beautiful and costly carpeting is fabricated, for those in the higher ranks; the coarser fibres are made into brooms. After these useful materials are taken from this leaf, the stem still remains, which is about the thickness of the ancle, and furnishes firewood.

889. *The wood of this palm,* when fresh cut, is spongy; but becomes hard, after being seasoned, and assumes a dark-brown color. On the top of the tree a large shoot is produced, which when boiled resembles brocoli, but is said to be of a more delicate taste; and though much liked, is seldom used by the natives; because on cutting it off the pith is exposed, and the tree dies. Between this cabbage-like shoot and the leaves, there spring several buds, from which, on making an incision, there distils a juice differing little from water, either in color or consistence. It is the employment of a certain class of men to climb to the top of the trees in the evening, with earthen pots tied to their waists, which they fix there to receive the juice, which is regularly carried away before the sun has had any influence upon it. This liquor is sold at the bazars by the natives, under the name of toddy. It is used for yeast, and forms an excellent substitute. In this state it is drank with avidity, both by the low Europeans and the natives; and it is reckoned a cooling and agreeable beverage. After being kept a few hours, it begins to ferment, acquires a sharp taste, and a slight intoxicating quality. By boiling it, a coarse kind of sugar is obtained; and by distillation, it yields a strong ardent spirit, which being every where sold, and at a low price, constitutes one of the most destructive annoyances to our soldiers. The name given to this pernicious drink by Europeans, is pariah attack, from the supposition that it is only drank by the pariahs, or out-casts, that have no rank.

890. *The trees from which the toddy is drawn* do not bear any fruit, on account of the destruction of the buds; but if the buds be left entire, they produce clusters of the cocoa-nut. This nut, in the husk, is as large as a man's head; and when ripe falls with the least wind. If gathered fresh, it is green on the outside; the husk and the shell are tender. The shell, when divested of the husk, may be about the size of an ostrich's egg, and is lined with a white pulpy substance, which contains about a pint and a half of liquor like water; and though the taste be sweet and agreeable, it is different to that of the toddy.

891. *In proportion as the fruit grows old,* the shell hardens, and the liquor diminishes, till it is at last entirely absorbed by the white milky substance; which gradually acquires the hardness of the kernel of the almond, and is almost as easily detached from the shell. The natives use this nut in their vintages; and from it they also express a considerable quantity of the purest and best lamp oil. The substance which remains after this operation supplies an excellent food for poultry and hogs. Cups and a variety of excellent utensils are made of the shell.

892. *The husk of the cocoa-nut* is nearly an inch thick, and is, perhaps, the most valuable part of the tree; for it consists of a number of strong fibres, easily separable, which furnishes the material for the greatest part of the Indian cordage; but is by no means the only substitute which the country affords for hemp. This the natives work up with much skill.

893. *The palmyra,* a species of corypha, is taller than the cocoa tree; and affords still greater supplies of toddy; because its fruit is of little request from the smallness of its size; the produce of the tree is therefore generally drawn off in the liquid state. This tree, like the cocoa, has no branches; and, like it too, sends forth from the top a number of large leaves, which are employed in thatching houses, and in the manufacture of mats and umbrellas. The timber of the tree is much used in building.

894. *The date tree (Phoenix dactylifera),* being smaller, makes not so conspicuous a figure in the Indian forest as the two last described. Its fruit never arrives at maturity in India owing to the heat: toddy is drawn from it, but not in such quantity, nor of so good a quality, as that which is produced by the other species of the same genus.



895. *The bamboo* (*Arundo bambos*) is, perhaps, one of the most universally useful trees in the world; at all events it is so in the tropical regions. There are above fifty varieties, all of which are of the most rapid growth, rising from fifty to eighty feet the first year, and the second perfecting its timber in hardness and elasticity. It grows in stools, which are cut over every two years, and thus the quantity of timber furnished by an acre of bamboos is immense. Its uses are almost without end. In building it forms entire houses for the lower orders, and enters both into the construction and furniture of those of the higher classes. Bridges, boats, masts, rigging, agricultural and other implements, and machinery, carts, baskets, ropes, nets, sailcloth, cups, pitchers, troughs, pipes for conveying water, pumps, fences for gardens and fields, &c., are made of it. Macerated in water it forms paper; the leaves are generally put round the tea sent to Europe; the thick inspissated juice is a favorite medicine, is said to be indestructible by fire, to resist acids, and by fusion with alkali to form a transparent permanent glass.

896. *The fruits of Hindustan* may be said to include all those in cultivation; since the hardier fruits of Europe, as the strawberry, gooseberry, apple, &c. are not only grown by the European settlers in cool situations, but even by the native shahs. The indigenous sorts include the mango, the mangostan (*fig. 136.*), and the durion (*fig. 137.*), the noblest of known fruits next to the pine apple.



897. *The natural pastures of Hindustan* are every where bad, thin and coarse, and there is no such thing as artificial herbage plants. In Bengal, where the soil is deep and loamy to the depth of nine and ten feet, a coarse bent, or species of juncus, springs up both in the pasture and arable lands, which greatly deteriorates the former as food for cattle, and unfits the latter for being ploughed. This juncus, Tennant observes, pushes up a single seed stem, which is as hard as a reed, and is never touched by cattle so long as any other vegetable can be had. Other grasses of a better quality are sometimes intermixed with this unpalatable food; but during the rain their growth is so rapid that their juices must be ill fitted for nutrition. In Upper Hindustan, during the dry season, and more particularly the prevailing of the hot winds, every thing like verdure disappears; so that on examining a herd of cattle, and their pasture, you are not so much surprised at their leanness, as that they are alive. The grass cutters, a class of servants kept by Europeans for procuring food for their horses, will bring provender from a field where grass is hardly visible. They use a sharp instrument, like a trowel, with which they cut the roots below the surface. These roots, when cleared of earth by washing, afford the only green food which it is here possible to procure.

898. *The live stock of Hindustan* consists chiefly of beasts of labor; as the natives are by their religion prohibited the use of animal food. The horses are chiefly of Persian or Arabian extraction. The Bengal native horse is thin and ill-shaped, and never equals the Welsh or Highland poney, either in figure or usefulness. The buffalo is common, both tame and wild, and generally jet black, with semicircular horns, laid backwards upon the neck. They are preferred to the ox for carrying goods, and kept in herds for the sake of their milk, from which ghee, an universal article of Hindoo diet, is made.

899. *The common ox of Hindustan* is white, and distinguished by a protuberance on the shoulder, on which the yoke rests. Those kept for travelling-coaches are capable of performing long journies nearly in the same time with horses; those kept by the poor ryots work patiently in the yoke beneath the vertical sun, for many hours, and upon the most wretched food, chaff or dried straw. The cow is held sacred, and worshipped; and paintings are made on the walls with her dung, which are objects of superstition.



900. *The sheep* is small, lank, and thin; and the wool chiefly black or dark grey. The fleece is harsh, thin, and hairy, and only used for a kind of coarse wrappers or blanket-ing. A somewhat better breed are found in the province of Bengal; but the mutton of neither is good till the animals are improved by a year's good keeping.

901. *The goat* is kept for its milk, which is commonly used at the breakfast table; and also for the flesh of the kids, which is more tolerable than mutton.

902. *Swine* are not very common, though herds may be seen in Bengal. They might be reared in abundance; but the natives are strictly forbidden the use of pork; and it is only eaten by the Europeans, and some of the out-casts. Wild hogs are abundant, and do so much injury to the rice fields, that it is a material part of the ryot's business to watch them, which he does night and day, on a raised platform of bamboos (fig. 138.)

903. *The elephant* is chiefly used in war, but is also kept by a few European gentlemen, for hunting or show. He is taken by stratagem, and by feeding and gentle usage soon becomes tame, docile, and even attached to his keeper; but does not breed in a domesticated state. His food is the leaves and smaller branches of trees, and an allowance of grain. It is a singular deviation from general nature, that an old elephant is easier tamed than one taken young.

904. *The camel* is used chiefly as a beast of burden, and is valued for its uncommon power of abstinence from drink. He is also patient of fatigue, hunger, and watching to an incredible degree. These qualities have recommended the camel, as an auxiliary to British officers for carrying their baggage; and from time immemorial, he has been used by merchants for conveying goods over extensive tracts of country.

905. *The predatory animals* are numerous. Of these the jackal (fig. 139.) is the most remarkable. He enters at night every farm-yard, village, and town, and traverses even the whole of Calcutta. His voracity is indiscriminate, and he acts as a scavenger in the towns; but, in the farm-yards he is destructive to poultry, if he can get at their roosts; and in the fields the hare and the wild pig sometimes become his prey. The numerous parish dogs, which in general are mangy, are almost as troublesome as the jackal. Apes of different kinds haunt houses, and pilfer food and fruits. The crow, kite, mino, and sparrow hop about the dwellings of man with a familiarity unknown in Europe, and pilfer from the dishes of meat, even as they are carried from the kitchen to the eating room. The stork is common; and toads, serpents, lizards, and other reptiles and insects, are greatly kept under by him and other birds.

906. *The implements and operations of Hindustanee agriculture* are as simple as can well be imagined. The

plough, of which Major Beatson has given several forms (fig. 140.), is little better than a pointed stick, and is carried to the field on the shoulder like the spade. It scratches the sandy uplands, or the mud left by the rivers in a tolerable manner; but the strong lands of Bengal, that send up the juncus already mentioned (897.),

appear as green after one ploughing as before; "only a few scratches are perceptible here and there, more resembling the digging of a mole than the work of the plough." To accomplish the work of pulverization, the ploughman repeats the operation from five to fifteen times, and at last succeeds in raising mould enough to cover the seed: one plough and pair is allowed to five acres. From this mode of repeatedly going over the same surface, and effecting a little each time, governor Beatson has drawn some ingenious arguments in favor of the use of the cultivator in this country, which will be afterwards noticed.

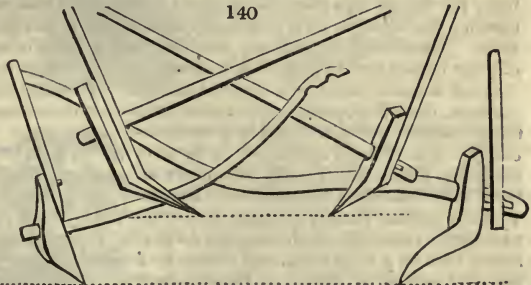

907. *The cart, or hackery, has two wheels, and is drawn by two bullocks. The wheels are under three feet in diameter, and the body of the carriage consists of two bamboos, united by a few cross bars, also of bamboo, and approaching each other the whole length of the machine, till they meet at a point between the necks of the cattle, where they are supported by a bar projecting sideways over the shoulders of both. By this the oxen or buffalos are often galled in a shocking manner, and the suppuration which takes place in consequence is, perhaps, not perfectly cured during the whole life of the animal; the evil being aggravated by the crows, which set upon him as soon as he is relieved from the yoke. Reaping is often performed by pulling by the roots instead of cutting or mowing, and the grain or seed is separated from the straw or stalks, by treading with oxen on a smooth part of the field.*

908. *As no department of aration can be carried on without artificial watering, that operation becomes very expensive, and troublesome in elevated districts. In the Mongheer district of Bengal, a deep well is dug in the highest part of the field. The fields, after being ploughed, are divided into little square plots, resembling the chequers of a backgammon table. Each square is surrounded with a shelving border, about four inches high, capable of containing water. Between the square chequers thus constructed, small dykes are formed for conveying a rivulet over the whole field. As soon as the water has stood a sufficient time in one square for it to imbibe moisture, it is let off into the adjoining one, by opening a small outlet through the surrounding dyke. Thus one square after another is saturated, till the whole field, of whatever extent, is gone over.*

909. *The water is raised in large leathern bags, pulled up by two bullocks, yoked to a rope. The cattle are not driven in a gin as ours, but retire away from the well, and return to its mouth, according as the bag is meant to be raised, or to descend. The rope is kept perpendicularly in the pit, by a pulley, over which it runs. From the mouth of the well thus placed, the rivulets are formed to every part of a field.*

910. *In the district of Patna the wells are not so deep. Here the leathern bags are raised by long bamboo levers, as buckets are in several parts of this country. In a few places rice is transplanted, which is done with pointed sticks, and the crop is found to be better than what is sown broadcast.*

911. *In the hilly districts they neither plough nor sow; what grain they raise is introduced into small holes, made with a peg and mallet, in a soil untouched by the plough. The only preparation given it is turning away the jungle, and thus depositing the seed. In the vicinity of Rajamah there are many tribes of peasants, who subsist partly by digging roots, and by killing birds and noisome reptiles. In these savage districts ninety villages have been taxed for two hundred rupees; and yet this paltry sum could only be made up by fruits peculiar to the situation. The wretched state of these peasants, Dr. Tennant observes, outdoes every thing which an European can imagine.*

912. *Harvests are made at different seasons of the year; and as often as a particular crop is collected, the ryot sends for the brahmin, or parish priest, who burns ghee, and says prayers over the collected heap, and receives one measure of grain for his trouble.*

913. *The selections we have now submitted will give some idea of the aboriginal agriculture of Hindustan; not in its details, but as to its peculiar features. It is evidently wretched, and calculated for little more than the bare sustenance of an extensive population; for though the revenue of the state is in fact the land rent; that revenue, notwithstanding the immense tract of country from which it is collected, is known to be very little. The state of agriculture, however, both politically and professionally, is capable of great improvement; and it is believed, the present government has already effected material benefits, both to the natives and itself. Wherever the British influence is pre-eminent, there Europeans settle, and introduce improvements; and even the more industrious Asiatics find themselves in greater security. The Chinese are known to be a remarkably industrious people, and many of them have established themselves in British-Indian seaports. Wathen (*Voyage, &c.* 1814.) mentions, a corn-mill, combining also a bake-house, both on a large scale, and driven by a powerful stream of water, at Penang, near Madras, as having been established by Amee, a Chinese miller. The building is in the Chinese taste, and forms a very picturesque group in a romantic spot (*fig. 141.*) About sixty people are employed; though great part of the labor is done by machinery, and among other things the kneading of the dough. The shipping is the chief source of consumption.*



SUBJECT. 6. *Of the Agriculture of the Island of Ceylon.*

914. *The agriculture of Ceylon* is noticed at some length by Dr. Davy, who says the art is much respected by the Singalese. The climate of that country is without seasons, and differs little throughout the year in any thing but in the direction of the wind, or the presence or absence of rain. Sowing and reaping go on in every month of the year.

915. *The soil of Ceylon* is generally silicious, seldom with more than from one to three per cent. of vegetable matter. Dr. Davy (*Account, &c.*) found the cinnamon tree in a state of successful culture in quartz sand, as white as snow on the surface, somewhat grey below, containing one part in one hundred of vegetable matter; five-tenths of water, and the remainder silicious sand. He supposes the growth of the trees may be owing in a considerable degree to the situation being low and moist.

916. *The cultivation in the interior of Ceylon* is almost exclusively of two kinds; the dry and wet. The former consists of grubbing up woods on the sides of hills, and sowing a particular variety of rice and Indian corn; the latter is carried on in low flat surfaces, which may be flooded with water. Rice is the only grain sown; the ground is flooded previously to commencing the operation of ploughing, and is kept under water while two furrows are given; the water is then let off, and the rice being previously steeped in water, till it begins to germinate, is sown broadcast. When the seed has taken root, and before the mud has had time to dry, the water is re-admitted: when the plants are two or three inches high the ground is weeded, and any thin parts made good by transplanting from such as are too thick. The water remains on the field till the rice begins to ripen, which is commonly in seven months: it is then let off and the crop cut down with reaping hooks, and carried to the threshing floor, where it is trod out by buffaloes.

917. *The agricultural implements of the Singalese* are few and simple; they consist of jungle hooks, (*fig. 142 a.*), for cutting down trees and underwood; an axe (*b*); a sort of

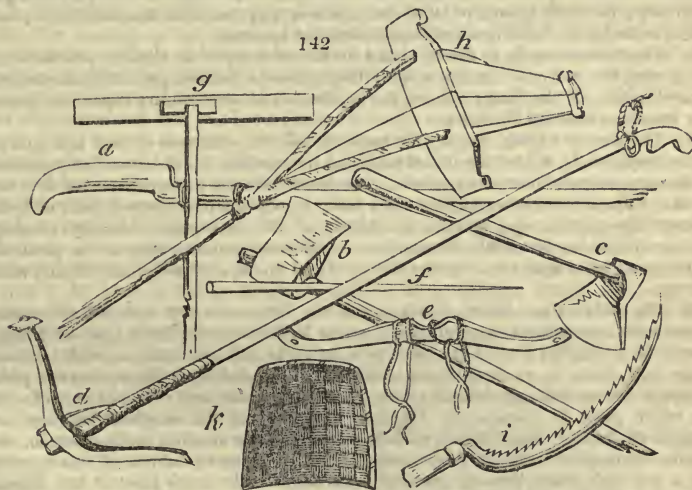

French spade or *bêche* (*c*); a plough of the lightest kind (*d*), which the ploughman holds with one hand, the beam being attached to a pair of buffaloes, by a yoke (*e*), and with the other, he carries a long goad (*f*), with which, and his voice, he directs and stimulates the animals. A sort of level (*g*) is used for levelling the ground after ploughing, which, like the plough, is drawn by a pair of buffaloes, the driver sitting on it to give it momentum. For smoothing the surface of the mud preparatory to sowing, a sort of light scraper (*h*) is employed. The reaping hook (*i*) is similar to ours; their winnow (*k*) is composed of strong matting, and a frame of rough twigs. The threshing floor is made of beat clay; and previous to commencing the operation of treading out, a charm (*fig. 143 l.*) is drawn on the middle of the floor. A forked stick (*m*) is used to gather and stir up the straw under the buffaloes' feet. (*Davy's Ceylon, 278.*)



918. *A Singalese farm-yard* bears some resemblance to one of this country (fig. 144.): but fewer buildings, and no barn is required.

144



919. *An embankment*, or retaining mound, by which an artificial lake of three or four miles in circumference is dammed up, is described by Dr. Davy. It is nearly a straight line across the valley, twenty feet high, and 150 or 200 feet wide; the side next the water forming an angle of  $45^{\circ}$ , and faced with large stones, in the manner of steps. This must have been a work of great labor to so rude and simple a people.

**SUBJECT. 7.** *Present State of Agriculture in the Birman Empire, in Java, Malacca, Siam, Cochin China, Tonquin, Japan, &c.*

920. *The agriculture of these countries* and others of minor note adjoining them, differs little as far as it is known from that of Hindustan. In all of them the sovereign is the lord of the soil; the operative occupier is wretchedly poor and oppressed. The chief product is rice; the chief animal of labor the buffalo or ox; the chief manure, water; and the chief material for buildings and implements, the bamboo.

921. *The Birman empire* is distinguished for the salubrity of its climate, and the health and vigor of the natives. In this respect they possess a decided pre-eminence over the enervated natives of the East; nor are the inhabitants of any country capable of greater bodily exertions than the Birmans.

922. *The seasons* of this country are regular, and the extremes of heat and cold are seldom experienced; at least the duration of that intense heat which immediately precedes the commencement of the rainy season, is so short that the inconvenience of it is very little felt. The forests, however, like some other woody and uncultivated parts of India, are extremely pestiferous; and an inhabitant of the champaign country considers a journey thither as inevitable destruction. The wood-cutters, who are a particular class of men, born and bred in the hills, are said to be unhealthy, and seldom attain longevity.

923. *The soil* of the southern provinces of the Birman empire is remarkably fertile, and produces as luxuriant crops of rice as are to be found in the finest parts of Bengal. Towards the north, the face of the country is irregular and mountainous, with headlong torrents and rivers in yawning chasms, crossed by astonishing bridges; but the plains and valleys are exceedingly fruitful; they yield good wheat and various kinds of small grain which grow in Hindustan, together with most of the esculent legumes and vegetables of India. Sugar-canes, tobacco of a superior quality, indigo, cotton, and the different tropical fruits in perfection, are all indigenous products of this country. Besides the teak tree (*Tectoria grandis*), which grows in many parts of the Birman empire, as well to the north of Ummerapoora, as in the southern country, there is almost every description of timber that is known in India.

924. *The cattle* used in some parts of the country for tillage and draught, are remarkably good; they put only a pair of them to the plough, which is little different from the plough of India, and turns up the soil very superficially. In their large carts they yoke four stout oxen, which proceed with the speed of a hand-gallop, and are driven by a country girl, standing up in her vehicle, who manages the reins and a long whip with ease and dexterity. Many of the rising grounds are planted with indigo; but the natives suffer the hills for the most part to remain uncultivated, and only plough the rich levels. They every where burn the rank grass once a year to improve the pasture. The Birmans will not take much pains; they leave half the work to nature, which has been very bountiful to them. In the neighbourhood of Loonghe many fields are planted with cotton, which thrives well; sesamum is also cultivated in this soil, and is found to answer better than rice, which is most productive in low and moist grounds. In the suburbs of Pagahm, there are at least two hundred mills employed in expressing oil from the sesamum seed. In this operation the grain is put into a deep wooden trough, and pressed by an upright timber fixed in a frame; the force is increased by a long

lever, on the extremity of which a man sits and guides a bullock that moves in a circle ; thus turning and pressing the seed at the same time. The machine is simple, and yet effectually answers the purpose.

925. *Among the vegetable productions of this country*, we may enumerate the white sandal-tree, and the alæxylum verum, producing the true jet black ebony wood ; the sycamore fig, Indian fig, and banyan tree ; the bignonia indica, nauclea orientalis, corypha scribus, one of the loftiest of the palm trees, and excoecaria cochinchinensis, remarkable for the crimson under surface of its leaves. To the class of plants used in medicine and the arts, we may refer the ginger and cardamum, found wild on the sides of rivers, and cultivated in great abundance ; the turmeric, used by the natives of the coast to tinge and flavor their rice, and other food ; the betel pepper, fagara piperitæ, and three or four kinds of capsicum ; the justicia tinctoria, yielding a beautiful green tinge ; morinda umbellata, gamboge, and carthamus, furnishing yellow dyes ; the red wood of the lawsonia spinosa, and cisalpina sapan, and the indigo. The bark of the nerium antidysentericum, called codagapala, and that of the laurus culilavan, the fruit of the strychnos nux vomica, the cassia fistula, the tamarind, and the croton tiglium, the inspissated juice of the aloe, the resin of the camphor tree, and the oil of the ricinus, are occasionally imported from this country for the European dispensaries. The cinnamon laurel, sometimes accompanied by the nutmeg, the sugar-cane, bamboo, and spikenard, are found throughout the whole country ; the last on dry hills ; and the bamboo and sugar cane in rich swamps. The sweet potatoe, ipomœa tuberosa, mad-apple, and love-apple (solanum melongena, and lycopersicon), nymphæa, nelumbo, gourds, melons, water-melons, and various other esculent plants, enrich, by cultivation, this country ; and the plantain, cocoa-nut, and sago palm, are produced spontaneously. The vine grows wild in the forests, but its fruit is indifferent for want of cultivation, and through excess of heat, to that of the south of Europe ; but this country is amply supplied with the mango, pine-apple, sapindus edulis, mangostan plum, avertroa, carambola, custard-apple, papaw-fig, orange, lemon, and lime, and many other exquisite fruits.

926. *The animals of the Birman empire* correspond with those of Hindustan. The wild elephants of Pegu are very numerous ; and, allured by the early crops of rice, commit great devastation among the plantations that are exposed to their ravages. The king is the proprietor of these animals ; and one of his Birman majesty's titles is "lord of the white elephants and of all the elephants in the world." The forests abound with tigers. Their horses are small, but handsome and spirited, hardy and active ; and are frequently exported in timber-ships bound for Madras and other parts of the coast, where they are disposed of to considerable advantage. Their cows are diminutive, resembling the breed on the coast of Coromandel ; but their buffaloes are noble animals, much superior to those of India, and are used for draught and agriculture ; some of them are of a light cream colour, and are almost as fierce as tigers, who dare not molest them. The ichneumon, or rat of Pharaoh, called by the natives ounbaï, is found in this country : but there is no such animal as the jackal in the Ava dominions, though they are very numerous in the adjoining country. Among the birds, which are the same with those of other parts of India, is one called the henza, the symbol of the Birman nation, as the eagle was of the Roman empire. It is a species of wild fowl, called in India the Bramin goose ; but the natives of Ava do not deify this bird.

927. *The agriculture of Java* has been noticed by Thunberg, and more fully described by Sir Stamford Raffles.

928. *The climate of Java*, like that of other countries situated within about ten degrees of the equator, presents a perpetual spring, summer, and harvest. The distinction of weather is into wet and dry, never hot and cold, and rain depends on the winds.

929. *The surface of the country* is low towards the coast, but hilly in the interior ; unhealthy about Batavia, but in most other parts as salubrious as any other tropical country.

930. *The soil* is for the most part rich, and remarkable for its depth ; probably, as Governor Raffles conjectures, owing to its volcanic origin.

931. *Landed property in Java* is almost exclusively vested in the king, between whom and the cultivator there are no intermediate holders ; and the cultivator is without lease or right beyond the will of the sovereign. The manner in which the king draws his income from the whole surface of the country is by burdening certain "villages or estates with the salaries of particular officers, allotting others for the support of his relatives or favorites, or granting them for the use of particular charitable institutions ; in the same manner as before the consolidation act in Britain, the interest of particular loans was paid upon the produce of specific imports." Tradesmen, government officers, priests, and the government, are all alike paid in kind.

932. *The crops raised by the farmer for home consumption* are chiefly rice and maize, some wheat is also grown ; but the staple article is rice, of which one pound and a half per day is considered sufficient nourishment for an adult.

933. *The crops raised by the colonists* are coffee, sugar, cotton, tobacco, and a variety of other productions of the East. One of the principal articles is coffee, which is first raised in seed-beds, then transplanted under an open shed for the sake of shade, and then in about eighteen months removed into the garden or plantation where they are destined to yield their fruit. A plantation is laid out in squares, the distance of plant from plant being commonly about six feet, and in the centre of each four trees, is placed a *dadap tree*, for the purpose of affording shade, which in Java seems necessary to the health of the coffee plant. It is never pruned, grows to the height of sixteen feet; will bear for twenty years: but a plantation in Java is seldom continued more than ten years. In general three crops of berries are produced in a season.

934. *The live stock* of the Java farmer, is the ox and buffalo, used in ploughing; and the horse for burden: they have a few sheep, and goats, and poultry.

935. *The implements* are the plough, of which they have a common, or rice-ground, sort; a dry-soil plough, and a garden or plantation plough, all of which are yoked to a pair of buffaloes, or oxen, in the same manner. The harrow (fig. 145 a), on which the

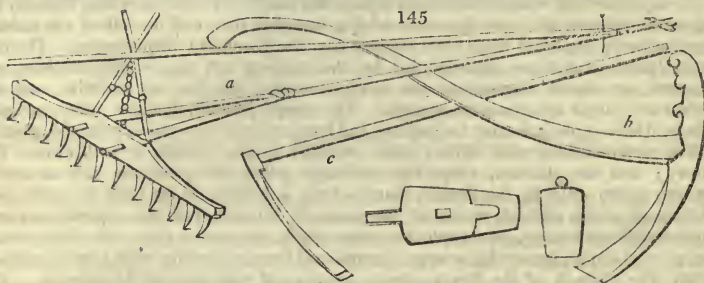

driver sits, is a sort of rake; and they have a sort of strong hoe, which they use as a substitute for a spade (b), and a lighter one, used as a draw hoe (c). Their knives for weeding, pruning, and reaping (fig. 146 a to f), are very curious; one of them (g), is used both as an axe and bill, and another (h), as a thrust hoe and pruning hook. It is observed by Governor Raffles, that in reaping they crop off "each separate ear along with a few inches of the straw;" an "operose process" which he was informed had its origin in some religious notions. Crops are generally dibbled or transplanted: no manure is even required or given in Java excepting water. In ploughing for rice, the land is converted into a semifluid mire, in which the plants are inserted. A curious mode is made use of to scare the birds from ripening crops. An elevated shed is raised in the middle of the plantation or field, within which a child on the watch touches from time to time a series of cords extending from the shed to the extremities of the field like the radii of a circle, and thus prevents the ravages of birds. The native cart of Java is a clumsy conjunction of boards, running on two solid wheels from five to six feet in diameter, and only from one to two inches broad on a revolving axle. It is drawn by two buffaloes.

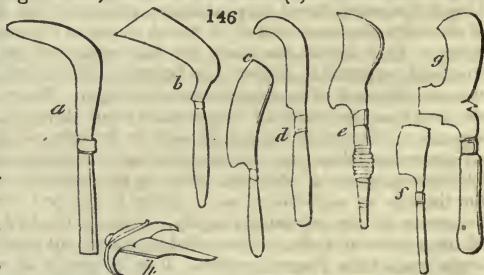

936. *The uyas or poison tree*, (*Rhus*, sp.?) has been said to be a native of and peculiar to Java; but Dr. Horsfield and other botanists have ascertained that there is no tree in the island answering its description: there are two trees used for poisoning warlike instruments, but neither are so powerful as to be used alone; and, indeed, they are in no way remarkable either as poison plants or trees. The *rafflesia arnoldii*, the most extraordinary parasitic plant known to botanists, is believed to be a native of this island as well as of Sumatra, where it was originally found.

937. *The roads of Java*, Sir Stamford Raffles observes, are of a greater extent and of a better description than in most countries. A high road, passable for carriages at all seasons of the year, runs from the western to the eastern extremity of the island, a distance of not less than eight hundred English miles, with post stations and relays of horses every five miles. The greater part of it is so level that a canal might be cut along its side. There is another high road which crosses the island from north to south, and many intersecting cross roads. The main roads were chiefly formed by the Dutch.

as military roads, and "so far," Governor Raffles continues, "from contributing to the assistance of the agriculture or trade of Java, their construction has, on the contrary, in many instances been destructive to whole districts. The peasant who completed them by his own labor, or the sacrifice of the lives of his cattle, was debarred from their use, and not permitted to drive his cattle along them, while he saw the advantages they were capable of yielding reserved for his European masters, who thus became enabled to hold a more secure possession of his country." (*History of Java, &c.* i. 198.)

938. *Of the peninsula of Malacca* very little is known. Agriculture is carried on in the marginal districts of the country; but the central parts are covered with unexplored forests, which swarm with wild men and women, (*fig. 147.*) monkeys, tigers, wild boars, elephants, and other animals. The chief grain cultivated is rice; and the chief exports are, pepper, ginger, gum, and other spices, raisins, and woods. Game and fruits abound. "The lands (*Le Pouvre* observes) are of a superior quality; and covered with odoriferous woods; but the culture of the soil abandoned to slaves, is fallen into contempt. These wretched laborers, dragged incessantly from their rustic employments by their restless masters, who delight in war and maritime enterprises, have rarely time, and never resolution, to give the necessary attention to the laboring of their grounds."



147

939. *The kingdom of Siam* may be described as a wide vale between two high ridges of mountains; but compared with the Birman empire, the cultivated land is not above half the extent either in breadth or length.

940. *The agriculture of the Siamese* does not extend far from the banks of the river, or its branches; so that towards the mountains there are vast aboriginal forests filled with wild animals, whence they obtain the skins which are exported. The rocky and variegated shores of the noble gulf of Siam, and the size and inundations of the Meinam, conspire with the rich and picturesque vegetation of the forests, illumined at night by crowds of brilliant fire-flies, to impress strangers with admiration and delight.

941. *The soil* towards the mountains is parched and infertile; but on the shores of the river consists, like that of Egypt, of a very rich and pure mould, in which a pebble can scarcely be found; and the country would be a terrestrial paradise if its government were not so despotic as to be justly reckoned far inferior to that of their neighbors the Birmans. Rice of excellent quality is the chief product of their agriculture; wheat is not unknown; pease and other vegetables abound; and maize is confined to their gardens. The fertility of Siam depends in a great degree, like that of Egypt or the Nile, on their grand river Meinam and its contributory streams.

942. *The kingdom of Laos* borders on China, and is surrounded by forests and deserts, so as to be of difficult access to strangers. The climate is so temperate, and the air so pure, that men are said to retain their health and vigor, in some instances, to the age of one hundred years. The flat part of the country resembles Siam, (*fig. 148.*) The soil

148



on the east bank of the river is more fertile than that on the west. The rice is preferred

to that of other oriental countries. Excellent wax and honey are produced in abundance, and the poppy, ginger, pepper, and other plants are cultivated, and their products exchanged with the Chinese for their cloths.

943. *Cambodia*, like Siam, is enclosed by mountains on the east and west; and fertilised by an overflowing river. The climate is so hot that the inhabitants are under the necessity of residing on the banks of the rivers and lakes, where they are tormented by musquitos. The soil is fertile, and produces abundance of corn, rice, excellent legumes, sugar, indigo, opium, camphor, and various medicinal drugs. The most peculiar product is the gamboge-gum (*Stalagmitis cambogioides*), which yields a fine yellow tint. Ivory, also, and silk, are very plentiful, and of little value. Cattle, particularly of the cow kind, are numerous, and cheap. Elephants, lions, tigers, and almost all the animals of the deserts of Africa, are found in Cambodia. It has several precious woods, among which are the sandal and eagle-wood, and a particular tree, in the juice of which they dip their arrows; and it is said, that though a wound from one of the arrows proves fatal, the juice itself may be drank without danger. The country, though fertile, is very thinly peopled.

944. *Cochin China* presents an extensive range of coast, but few marks of tillage. Besides rice and other grains, sugar, silk, cotton, tobacco, yams, sweet potatoes, pumpkins (fig. 149.), melons, and other culinary vegetables, are cultivated; and cinnamon, pepper, ginger, cardamoms, silk, cotton, sugar, aila wood, japan wood, Columba and other woods and spice plants abound in the woods and copses. The horses are small, but active; and they have the ox, buffalo, mules, asses, sheep, swine, and goats. Tigers, elephants, and monkeys abound in the forests, and on the shores are found the edible swallows' nests, esteemed a luxury in the East, and especially in China. These nests are ascertained to be formed of a species of sea-weed, the *fucus lichnoides* of botanists. Almost every kind of domestic animal, except sheep, appears to be very plentiful. In Cochin China they have bullocks, goats, swine, buffaloes, elephants, camels, and horses. In the woods are found the wild boar, tiger, rhinoceros, with plenty of deer: they account the flesh of the elephant a great dainty, and their poultry is excellent. They pay little attention to the breeding of bullocks, as the tillage of their land is performed by buffaloes, and their flesh is not esteemed as food. The sea, as well as the land, is a never-failing source of sustenance to those who dwell on the coast. Most of the marine worms distinguished by the name of molusca, are used as articles of food by the Cochin Chinese. All the gelatinous substances derived from the sea, whether animal or vegetable, are considered by them the most nutritious of all aliments; and on this principle various kinds of sea-weeds, particularly the *fuci* and *algæ*, are included in their list of edible plants. The Cochin Chinese collect likewise many of the small succulent, or fleshy plants, which are usually produced on salt and sandy marshes, which they either boil in their soups, or eat in a raw state, to give sapidity to their rice, which with them is the grand support of existence. In Cochin China they are almost certain of two plentiful crops of rice every year, one of which is reaped in April, the other in October. Fruits of various kinds, as oranges, bananas, figs, pine apples, pomegranates, and others of inferior note, are abundantly produced in all parts of the country. They have very fine yams, and plenty of sweet potatoes. Their small breed of cattle does not appear to furnish them with much milk; but of this article they make a sparing use, even with regard to their young children.

945. *Tonquin*, in regard to surface, may be divided into two portions, the mountainous and the plain. The mountains are neither rocky nor precipitous, and are partly covered with forests. The plain is flat like Holland, being intersected by canals and dykes, and varied by lakes and rivers. The chief agricultural product is rice, of which there are two harvests annually in the low country, but in the high lands only one. Wheat and wine are unknown. The mulberry-tree is common; and the sugar-cane is indigenous; but the art of refining the juice is unknown. The live stock are chiefly oxen, buffaloes, and horses; swine abound, and there are a few goats; but asses and sheep are unknown. Dogs, cats, and rats are eaten. Poultry, ducks, and geese abound, and are found wild in the forests. The eggs of ducks are heated in ovens, and produce young, which swarm on the canals and ponds. The forests contain deer, boars, peacocks, a peculiar kind of partridge, and quails. (fig. 150.) The tigers are large and destructive; one of which is said to have entered a town, and to have destroyed eighty-five people. The wild

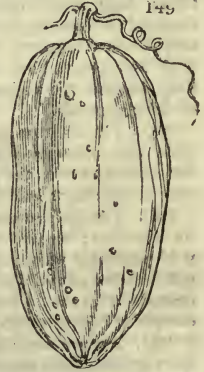



elephants are also very dangerous; apes are found in these forests, and some of them of large size: these and the parrots are not a little destructive to the rice and fruits. The Tonquin plough consists of three pieces of wood, a pole, a handle, and a third piece, almost at right angles with the last, for opening the ground; and they are simply fixed with straps of leather: this plough is drawn by oxen or buffaloes.

946. *The agriculture of Japan* is superior to that of most eastern countries.

947. *The climate of Japan* is variable. In summer the heat is violent; and, if it were not moderated by sea breezes, would be intolerable. The cold in winter is severe. The falls of rain commence at midsummer, and to these Japan owes its fertility, and also its high state of population. Thunder is not infrequent: tempests, hurricanes, and earthquakes are very common. From Thunberg's thermometrical observations it appears that the greatest degree of heat at Negasaki was 98° in August, and the severest cold in January, 35°. The face of the country presents some extensive plains, but more generally mountains, hills, and valleys; the coast being mostly rocky and precipitous, and invested with a turbulent sea. It is also diversified with rivers and rivulets, and many species of vegetables.

948. *The soil of Japan*, though barren, is rendered productive by fertilizing showers and manure, and by the operation of agricultural industry.

949. *Agriculture, Thunberg informs us, is here well understood*, and the whole country, even to the tops of the hills, is cultivated. Free from all feudal and ecclesiastical impediments, the farmer applies himself to the culture of the soil with diligence and vigour. Here are no commons; and it is a singular circumstance, that if any portion be left uncultivated, it may be seized by a more industrious neighbor. The Japanese mode of manuring is to form a mixture of all kinds of excrements, with kitchen refuse, which is carried in pails into the field, and poured with a ladle upon the plants, when they have attained the height of about six inches; so that they thus instantly receive the whole benefit. They are also very attentive to weeding. The sides of the hills are cultivated by means of stone walls, supporting broad plats, sown with rice or esculent roots. Rice is the chief grain; buckwheat, rye, barley, and wheat being little used. A kind of root, used as the potatoe (*Convolvulus edulis*), is abundant, with several sorts of beans, pease, turnips, cabbages, &c. From the seed of a kind of cabbage, lamp oil is expressed; and several plants are cultivated for dyeing; with the cotton shrubs and mulberry-trees for the food of silkworms. The varnish and camphor trees, the vine, the cedar, the tea tree, and the bamboo reed, not only grow wild, but are planted for numerous uses.

950. *In respect to live stock*, there are neither sheep nor goats in the whole empire of Japan; and, in general, there are but few quadrupeds. The food of the Japanese consists almost entirely of fish and fowl, with vegetables. Some few dogs are kept from motives of superstition; and cats are favorites of the ladies. Hens and common ducks are domesticated for the sake of their eggs.

#### SUBJECT. 8. *Present State of Agriculture in the Chinese Empire.*

951. *Agricultural improvement in China* has, in all ages, been encouraged and honored. The husbandman is considered an honorable as well as a useful member of society; he ranks next to men of letters or officers of state, of whom he is frequently the progenitor. The soldier, in China, cultivates the ground. The priests also are agriculturists, whenever their convents are endowed with land. Notwithstanding all these advantages, however, the Chinese empire is by no means so generally cultivated as Du Halde and other early travellers asserted. Some districts are almost entirely under cultivation; but in many there are extensive wastes.

952. *Dr. Abel is of opinion* that that part of China passed through by Lord Amherst's embassy, the land "very feebly productive in food for man, fully equalled that which afforded it in abundant quantity." He never found extensive tracts of land in general cultivation, but often great industry and ingenuity on small spots; and concludes that "as horticulturists the Chinese may perhaps be allowed a considerable share of merit; but on the great scale of agriculture, they are not to be mentioned with any European nations." (*Narrative, &c.* 127.)

953. *Barrow says*, few families cultivate more than is sufficient for their own use; that there are no teams, or dairies; that they are ignorant of the art of fattening cattle; and of the art of forming rotations of crops; that their implements are barbarous; and in short, that their agriculture, much as it has been vaunted by the Jesuits and some French philosophers, would be despised in Europe.

954. *Livingstone*, an intelligent resident in China, observes, "The statement in the *Encyclopædia Britannica*, that 'Chinese agriculture is distinguished and encouraged by the court beyond all other sciences,' is incorrect, since it is unquestionably subordinate to literature; and it may be well doubted whether it ought to be considered as holding among the Chinese the rank of a science; for, independently of that routine

which has been followed, with little variation, from a very high antiquity, they seem to be entirely ignorant of all the principles by which it could have been placed on a scientific foundation." (*Hort. Trans.* V. 49.)

955. *The climate of China is in general reckoned moderate, though it extends from the 50th to the 21st degree of south latitude, and includes three climates. The northern parts are liable to all the rigors of an European winter. Even at Pekin, at that season, the average of the thermometer is under 20° during the night, and in the day considerably below the freezing point. The heat of those parts which lie under the tropics is moderated by the winds from the mountains of Tatory. In the southern parts there is neither frost nor snow, but they are very subject to storms, especially about the time of the equinoxes; all the rest of the year the sky is serene, and the earth covered with verdure.*

956. *The surface of the country, though in general flat, is much diversified by chains of granite mountains, hills, rivers, canals, and savage and uncultivated districts, towns innumerable, villages, and cottages covered with thatch, reed, or palm leaves, and in some places with their gardens, or forecourts, fenced with rude pales, as in England. (fig. 151.) China, Dr. Abel observes, from the great extent of latitude contained in its*



boundaries, and from its extensive plains and lofty mountains, partakes of the advantages and defects of many climates, and displays a country of features infinitely varied by nature. Every thing artificial, however, has nearly the same characters in every province.

957. *The soil varies exceedingly: it is in many parts not naturally fertile; but has almost every where been rendered so by the application of culture and manure for successive ages.*

958. *The landed property of China is considered as the absolute right of the emperor: but the sub-proprietor, or first holder, is never turned out of possession as long as he continues to pay about the tenth part of what his farm is supposed capable of yielding. And, though the holder of lands is only considered as a tenant at will; it is his own fault if he is dispossessed. If any one happens to hold more than his family can conveniently cultivate, he lets it to another, on condition of receiving half the produce, out of which he pays the whole of the emperor's taxes. The greater part of the poor peasantry cultivate land on these terms. In China there are no immense estates, no monopolizing farmers, nor dealers in grain. Every one can bring his produce to a free and open market; no fisheries are here let out to farm. Every subject is equally intitled to the free and uninterrupted enjoyment of the sea, of the coasts, of the estuaries, of the lakes and rivers. There are no manor lords with exclusive privileges, nor any game laws.*

959. *The agricultural products of China extend to every useful vegetable. There is scarcely a grain, a fruit, a tree, or a culinary vegetable of Europe, or the rest of the world, that they do not cultivate; and they have a number peculiar to themselves. Fowl and fish are not extensively reared, as the chief articles of diet are vegetables; and they are ignorant of the use of milk, butter, or cheese. Rice is the common grain of the country; a species of cabbage, the universal culinary vegetable; swine, the most abundant live stock; and tea, the chief plant of export.*

960. *The tea districts of China extend from the 27th to the 31st degree of latitude.*

According to the missionaries, it thrives in the more northern provinces; and from Kämpfer it appears to be cultivated in Japan as far north as lat. 45°. It seems, according to Dr. Abel's observation, to succeed best on the sides of mountains, where there can be but little accumulation of vegetable mould. The soils from which he collected the best specimens consisted chiefly of sandstone, schistus, or granite. The land forming the Cape of Good Hope consisting of the same rocks, and its geographical position corresponding to that of the tea districts of China, Dr. Abel considers it might be grown there, if desirable, to such an extent as to supersede the necessity of procuring it from China. It grows well in St. Helena and Rio Janeiro, and will grow anywhere in a meagre soil and moderate temperature.

961. *The culture of the tea plant* in China has been given by various authors. It is raised from seeds sown where the plants are to remain. Three or more are dropped into a hole four or five inches deep; these come up without further trouble, and require little culture, except that of removing weeds, till the plants are three years old. The more careful stir the soil, and some manure it; but the latter practice is seldom adopted. The third year the leaves are gathered, at three successive gatherings, in February, April, and June, and so on till the bushes become stunted or tardy in their growth, which generally happens in from six to ten years. They are then *cut-in* to encourage the production of fresh shoots.

962. *The gathering of the leaves* is performed with care and selection. The leaves are plucked off one by one: at the first gathering only the unexpanded and tender are taken; at the second those that are full grown; and at the third the coarsest. The first forms what is called in Europe imperial tea; but as to the other names by which tea is known, the Chinese know nothing; and the compounds and names are supposed to be made and given by the merchants at Canton, who, from the great number of varieties brought to them, have an ample opportunity of doing so. These varieties, though numerous, and some of them very different, are yet not more so than the different varieties of the grape; they are now generally considered as belonging to one species; the *thea bohea*, now *camellia bohea* (fig. 152 a.) of botanists. Formerly it was thought that green tea was gathered exclusively from *thea viridis*; but that is now doubtful, though it is certain there is what is called the green tea district, and the black tea district; and the varieties grown in the one district differ from those grown in the other. Dr. Abel was unable to satisfy himself as to there being two species or one; but thinks there are two species. He was told by competent persons that either of the two plants will afford the black or green tea of the shops, but that the broad thin-leaved plant (*C. viridis*) is preferred for making the green tea.

963. *The tea leaves* being gathered, are cured in houses which contain from five to ten or twenty small furnaces, about three feet high, each having at the top a large flat iron pan. There is also a long low table covered with mats, on which the leaves are laid, and rolled by workmen, who sit round it: the iron pan being heated to a certain degree by a little fire made in the furnace underneath, a few pounds of the fresh-gathered leaves are put upon the pan; the fresh and juicy leaves crack when they touch the pan, and it is the business of the operator to shift them as quick as possible with his bare hands, till they become too hot to be easily endured. At this instant he takes off the leaves with a kind of shovel resembling a fan, and pours them on the mats before the rollers, who, taking small quantities at a time, roll them in the palm of their hands in one direction, while others are fanning them, that they may cool the more speedily, and retain their curl the longer. This process is repeated two or three times, or oftener, before the tea is put into the stores, in order that all the moisture of the leaves may be thoroughly dissipated, and their curl more completely preserved. On every repetition the pan is less heated, and the operation performed more slowly and cautiously. The tea is then separated into the different kinds, and deposited in the store for domestic use or exportation.

964. *The different sorts of black and green* are not merely from soil, situation, and age of the leaf; but after winnowing the tea, they are taken up in succession as the leaves fall; those nearest the machine, being the heaviest, is the gunpowder tea; the light dust the worst, being chiefly used by the lower classes. That which is brought down to Canton undergoes there a second roasting, winnowing, packing, &c., and many hundred women are employed for these purposes.



965. *As more select sorts of tea*, the blossoms of the *camellia sasangua* (fig. 152, b.) appear to be collected; as they are brought over land to Russia, and sold by Chinese and Armenians in Moscow at a great price. The buds also appear to be gathered in some cases. By far the strongest tea which Dr. Abel tasted in China, was that called Yu-tien, used on occasions of ceremony. It scarcely coloured the water, and on examination was found to consist of the half expanded leaves of the plant.

966. *As substitutes for tea* used by the Chinese may be mentioned a species of moss common to the mountains of Shan-tung; an infusion of ferns of different sorts, and Dr. Abel thinks the leaves of the common camellia and oil camellia may be added. Du Halde observes, that all the plants called tea by the Chinese, are not to be considered as the true tea plant; and Kämpfer asserts that in Japan a species of camellia as well as the *olea fragrans*, is used to give it a high flavor.

967. *The oil bearing tea plant* (*Camellia oleifera*) is cultivated for its seeds, from which an oil is expressed, in very general use in the domestic economy of China. It grows best in a red sandy soil, attaining the height of six or eight feet, and producing a profusion of white blossoms and seeds. These seeds are reduced to a coarse powder, either in a mortar by a pestle acted on by the cogs of a water-wheel (fig. 153.), or by a horizontal wheel, having small perpendicular wheels, shod with iron, fixed to its circumference, and acting in a groove lined with the same metal. The seeds when ground, are stewed or boiled in bags, and then pressed, when the oil is yielded. The press is a hollow cylinder, with a piston pressed against one end, by driving wedges at the side; it is very simple and yet powerful. (Dr. Abel's *Nar.* 176.) An oil used as a varnish is extracted from another variety of the camellia, or tea plant (the *Dryandria cordata* of Thunb.) which is used as a varnish for their boats, and coarser articles of furniture.

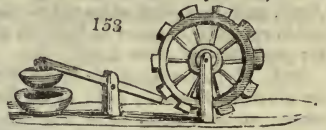

968. *The tallow-tree* (*Croton sebiferum*) resembles the oak in the height of its stem and the spread of its branches, and its foliage has the green and lustre of the laurel; its flowers are small and yellow, and its seeds white. The latter are crushed either as the camellia seeds, or in a hollow trunk of a tree, lined with iron, by means of a wheel laden with a heavy weight, (fig. 154.), and suspended from a beam. The bruised matter next undergoes nearly the same process as the camellia seeds, and the oily matter is found to have all the properties of animal tallow. It is mixed with vegetable oil and wax, to give it consistence, and then made into candles, which burn with great flame, emit much smoke, and quickly consume.



969. *The wax-tree*, or *Pe-la*, is a term which is not applicable to any one species of tree, but to such as are fastened on by a small worm, which runs up, and fastens to its leaves, covering them with combs. When these worms are once used to the trees of any district, they never leave them, unless something extraordinary drives them away. The wax produced is hard, shining, and considerably dearer than that of bees.

970. *The Sesamum orientale* and the *Ricinus communis*, or castor oil plant, are cultivated for the essential oils extracted from their seeds. They appear to have some method of depriving the castor oil of its purgative qualities, but Dr. Abel thinks not completely.

971. *The camphire tree* (*Laurus camphora*) grows to the size of our elms or oaks. The camphire is procured by boiling the fresh-gathered branches of the tree, and stirring the whole with a stick, till the gum begins to adhere to it in the form of a white jelly. The fluid is then poured off into a glazed vessel, and left to concrete. "The crude camphire is then purified in the following manner: a quantity of the finely-powdered materials of some old wall, built of earth, is put as a first layer at the bottom of a copper basin; on this is placed a layer of camphire, and then another of earth, and so on till the vessel is nearly filled; the series being terminated with a layer of earth: over this is laid a covering of the leaves of the plant *Po-tio*, perhaps a species of mentha. A second basin is now inverted over the first, and luted on. The whole thus prepared, is put over a regulated fire, and submitted to its action for a certain length of time; it is then removed and suffered to cool. The camphire is found to have sublimed, and to be attached to the upper basin, and is further refined by repetitions of the same process." (*Narrative*, &c. 179.)

972. *The oak* is as much prized in China as in other countries, and is styled the tree of inheritance. There are several species in general use for building, dyeing, and fuel; and the acorns are ground into a paste, which mixed with the flour of corn is made into cakes.

973. *The maidenhair tree (Salisburia adiantifolia)* is grown for its fruit, which Dr. Abel saw exposed in quantities; but whether as a fruit, a culinary vegetable, or a medicine, he could not ascertain. Kämpfer says, the fruit assists digestion.

974. *The cordage plant (Sida tiliaefolia)* is extensively cultivated for the manufacture of cordage from its fibres. The common hemp is used for the same purpose, but the sida is preferred. A species of musa is also grown in some places, and its fibres used for rope and other purposes.

975. *The common cotton*, and also a variety bearing a yellow down, and from which, without any dyeing process, the nankeen cloths are formed, is also grown in different places. The mulberry is grown in a dwarf state, as in Hindustan.

976. *The ground nut (Arachis hypogæa)*; the arum esculentum, or eatable arum; the trapa bicornis; the scirpus tuberosus, and nelumbium, all producing edible tubers, are cultivated in lakes, tanks, or marshy places.

977. *The Nelumbium*, Dr. Abel observes, with its pink and yellow blossoms, and broad green leaves, gives a charm and productiveness to marshes, otherwise unsightly and barren. The leaves of the plant are watered in the summer, and cut down close to the roots on the approach of winter. The seeds are in size and form like a small acorn without its cup; are eaten green, or dried as nuts, and are often preserved in sweetmeats; they have a nut-like flavor. Its roots are sometimes as thick as the arm, of a pale-green without, and whitish within; in a raw state they are eaten as fruit, being juicy and of a sweetish and refreshing flavor; and when boiled are served as vegetables.

978. *The Scirpus tuberosus*, or water chestnut, (fig. 155.) is a stoloniferous rush, almost without leaves, and the tubers are produced on the stolons. It grows in tanks, which are manured for its reception about the end of March. A tank being drained of its water, small pits are dug in its bottom; they are filled with human manure, and exposed to the sun for a fortnight; their contents are next intimately blended with the slimy bottom of the tank, and slips of the plant inserted. The water is now returned to the tank, and the first crop of tubers comes to perfection in six months. (Rox. Coromandel.)

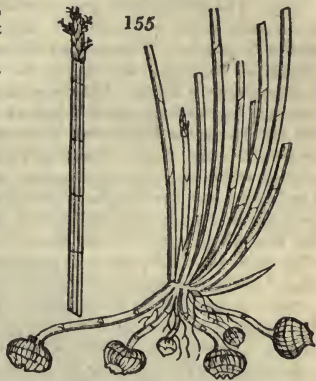

979. *The millet (Holcus)* is grown on the banks of rivers, and attains the height of sixteen feet. It is sown in rows, and after it comes up, panicum is sown between, which comes to perfection after the other is cut down.

980. Among the many esculent vegetables cultivated in China, the petsai, a species of white cabbage, is in most general use. The quantity consumed of it over the whole empire, is, according to all authors, immense; and Dr. Abel thinks it may be considered to the Chinese, what the potatoe is to the Irish. It is cultivated with great care, and requires abundant manuring, like its congeners of the brassica tribe. Boiled, it has the flavor of asparagus; and raw, it eats like lettuce, and is not inferior. It often weighs from fifteen to twenty pounds, and reaches the height of two or three feet. It is preserved fresh during winter by burying in the earth; and it is pickled with salt and vinegar.

981. Almost every vegetable of use, as food, in the arts, or as medicine, known to the rest of the world, is cultivated in China, with perhaps a very few exceptions of equatorial plants. The bamboo and cocoa-nut tree, as in Hindustan, are in universal use; indigo is extensively cultivated; sugar also in the southern provinces; but it is rather a luxury than an article of common consumption. It is used mostly in a coarse granulated form; but for exportation, and for the upper classes, it is reduced to its crystallized state. Tobacco is every where cultivated, and in universal use, by all ages, and both sexes. Fruits of every kind abound, but mostly bad, except the orange and the lee-tchee, Dimocarpus litchi, both of which are probably indigenous. The art of grafting is well known, having been introduced by the missionaries; but they do not appear to have taken advantage of this knowledge to the improvement of their fruits. They have also an art which enables them to take off bearing branches of fruit, particularly of the orange and peach, and transfer them, in a growing state, to pots, for their artificial rocks and grottos, and summer-houses. It is simply by removing a ring of the bark, plastering round it a ball of earth, and suspending a vessel of water to drop upon it, until the upper edge of the incision has thrown out roots into the earth.

982. *The live stock of Chinese agriculture* is neither abundant nor various. The greater part of their culture being on a small scale, and performed by manual operations, does not require many beasts of labor: their canals and boats supply the place of beasts of burden: and their general abstemiousness renders animals for the butcher less neces-

sary. They rear, however, though in comparatively small number, all the domestic animals of Europe; the horse, the ass, the ox, the buffalo, the dog, the cat, the pig; but their horses are small and ill-formed. The camels of China are often no larger than our horses; the other breeds are good, and particularly that of pigs. The kind of dog most common in the south from Canton to Tong-chin-tcheu, is the spaniel with straight ears. More to the north, as far as Peking, the dogs have generally hanging ears and slender tails.

983. *The Chinese are exceedingly sparing in the use of animal food.* Those important articles of milk, butter, and cheese, are wholly unknown to them. The broad-tailed sheep are kept in the hilly parts of the country, and brought down to the plains; but the two animals most esteemed, because they contribute most to their own subsistence, and are kept at the cheapest rate, are the hog and the duck. Whole swarms of the latter are bred in large barges, surrounded with projecting stages covered with coops, for the reception of these birds, which are taught, by the sound of the whistle, to jump into the rivers and canals in search of food, and by another call to return to their lodgings. They are usually hatched by placing their eggs, as the ancient Egyptians were wont to do, in small ovens, or sandbaths, in order that the same female may continue to lay eggs throughout the year, which would not be the case if she had a young brood to attend. The ducks, when killed, are usually split open, salted, and dried in the sun; in which state they afford an excellent relish to rice or other vegetables.

984. *The wild animals are numerous.* Elephants are common in the south of China, and extend as far as the thirtieth degree of north latitude in the provinces of Kiangnan and of Yun-nau. The unicorn rhinoceros lives on the sides of the marshes in the provinces of Yun-nau and Quan-si. The lion, according to Du Halde and Trigault, is a stranger to China; but the animal figured by Neuhoff, under the name of the tiger, seems to be the maneless lion known to the ancients, described by Oppian, and seen by M. Olivier on the Euphrates. Marco Polo saw lions in Fo-kien: there were some at the court of Kublai Khan. The true tiger probably shows himself in the most southerly provinces, where there are also various kinds of monkeys, the long-armed gibbou or *Simia longimana*; the *Simia influens*, or ugly baboon, and the *Simia silvana*, which mimics the gestures and even the laughter of men. The musk animal, which seems peculiar to the central plateau of Asia, sometimes goes down into the western provinces of China. The deer, the boar, the fox, and other animals, some of which are little known, are found in the forests.

985. *Several of the birds of the country are distinguished for beauty of form and brilliancy of colour;* such as the gold and silver pheasants, which we see often painted on the Chinese papers, and which have been brought to this country to adorn our aviaries; also the Chinese teal, remarkable for its two beautiful orange crests. The insects and butterflies are equally distinguished for their uncommon beauty. Silkworms are common, and seem to be indigenous in the country. From drawings made in China, it appears to possess almost all the common fishes of Europe; and M. Bloch, and M. de Lacepede had made us acquainted with several species peculiar to it. The Chinese gold-fish (*Cyprinus auratus*), which, in that country, as with us, is kept in basins as an ornament, is a native of a lake at the foot of the high mountain of Tien-king, near the city of Tchang-hoo, in the province of Tché-kiang. From that place it has been taken to all the other provinces of the empire, and to Japan. It was in 1611 that it was first brought to England.

986. *The fisheries of China, as already noticed, are free to all; there are no restrictions on any of the great lakes, the rivers, or canals.* The subject is not once mentioned in the *Leu-lee*; but the heavy duties on salt render the use of salt-fish in China almost unknown. Besides the net, the line, and the spear, the Chinese have several ingenious methods of catching fish. In the middle parts of the empire, the fishing corviant (*Pelicanus piscator*) is almost universally in use; in other parts, they catch them by torch light; and a very common practice is, to place a board painted white along the edge of the boat, which, reflecting the moon's rays into the water, induces the fish to spring towards it, supposing it to be a moving sheet of water, when they fall into the boat.

987. *The implements of Chinese agriculture are few and simple.* The plough has one handle, but no coulter; there are different forms: some may be drawn by women, (fig. 156 a), others are for stirring the soil under water, (b), and the largest is drawn by a single buffalo or ox (c). Horses are never employed for that purpose. The carts are low, narrow, and the wheels so diminutive as often to be made without spokes. A large cylinder is sometimes used to separate the grain from the ear, and they have a winnowing machine similar to that which was invented in Europe about a century ago. The most ingenious machines are those for raising water for the purposes of irrigation; a very ingenious wheel for this purpose has been figured by Sir George Staunton; but

the most universally used engine is the chain-pump, worked in various ways by oxen, walking in a wheel, or by the hand; and next to it buckets worked by long levers, (*fig. 157.*), as in the gardens round London, Paris, Constantinople, and most large cities of Europe. For pounding oleiferous seeds they have also very simple and economical machines, in which pestles on the ends of levers are worked by a horizontal shaft put in motion by a water-wheel. (*fig. 158.*) The chief thing to admire in the implements and machines of India and China is their simplicity, and the ease and little expence with which they may be constructed.

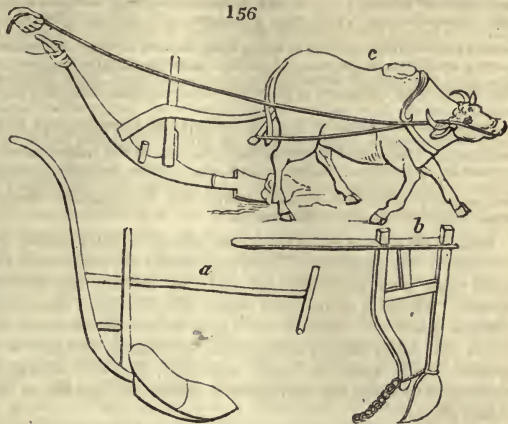

156

157

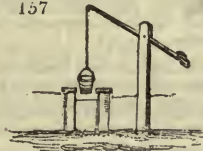

988. *The operations of Chinese agriculture are numerous, and some of them curious. Two great objects to be procured are water and manure. The former is raised from rivers or wells by the machines already mentioned, and distributed over the cultivated surface in the usual manner, and the latter from every conceivable source.*

allowed to remain till it is

989. *The object of their tillage, Livingstone observes, "appears to be, in the first instance, to expose the soil as extensively as possible; and this is best effected by throwing it up in large masses, in which state it is finally prepared for planting. When sufficient rain has fallen to*

158

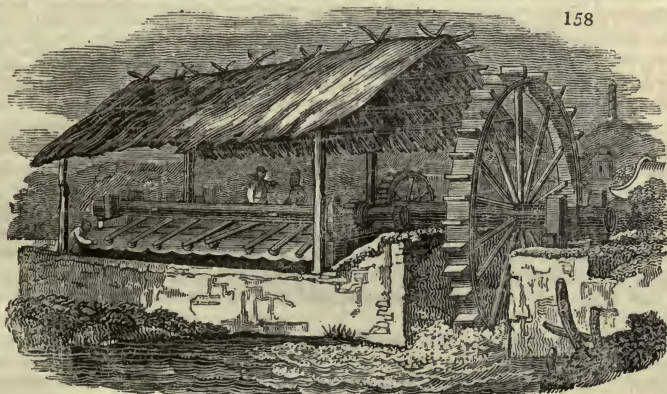

allow the husbandman to flood his fields, they are laid under water, in which state they are commonly ploughed again, in the same manner as for fallow, and then a rake, or rather a sort of harrow, about three feet deep and four feet wide, with a single row of teeth, is drawn, by the same animal that draws their plough, perpendicularly through the soil, to break the lumps, and to convert it into a kind of ooze; and as the teeth of this rake or harrow are not set more than from two to three inches apart, it serves at the same time, very effectually to remove roots, and otherwise to clean the ground. For some purposes, the ground thus prepared is allowed to dry; it is then formed into beds or trenches; the beds are made of a convenient size for watering and laying on manure. The intermediate trenches are commonly about nine inches deep, and of the necessary breadth to give to the beds the required elevation; but when the trenches are wanted for the cultivation of water plants, some part of the soil is removed, so that a trench may be formed of the proper dimensions.

990. *For these operations they use a hoe, commonly ten inches deep, and five inches broad, made of iron, or of wood with an iron border, and for some purposes it is divided into four or five prongs. By constant practice the Chinese have acquired such dexterous use of this simple instrument, that they form their beds and trenches with astonishing neatness and regularity. With it they raise the ground which has not been ploughed, from the beds and trenches, by only changing it from a vertical to a horizontal direction, or employing its edge. It is also used for digging, planting, and in general for every purpose which a Chinese husbandman has to accomplish.*

991. *The collection of manure is an object of so much attention with the Chinese, that a prodigious number of old men, women, and children, incapable of much other labor, are constantly employed about the streets, public roads, and banks of canals and rivers, with baskets tied before them, and holding in*

their hands small wooden rakes to pick up the dung of animals, and offals of any kind, that may answer the purpose of manure: this is mixed sparingly with a portion of stiff loamy earth, and formed into cakes, dried afterwards in the sun. It sometimes becomes an object of commerce, and is sold to farmers, who never employ it in a compact state. Their first care is to construct very large cisterns for containing, besides those cakes, and dung of every kind, all sorts of vegetable matter, as leaves, or roots, or stems of plants; mud from the canals, and offals of animals, even to the shavings collected by barbers. With all these they mix as much animal water as can be collected, or of common water, as can dilute the whole; and, in this state, generally in the act of putrid fermentation, they apply it to the ploughed earth. In various parts of a farm, and near the paths and roads, large earthen vessels are buried to the edge in the ground for the accommodation of the labourer or passenger who may have occasion to use them. In small retiring-houses, built also upon the brink of the roads, and in the neighborhood of villages, reservoirs are constructed of compact materials, to prevent the absorption of whatever they receive, and straw is carefully thrown over the surface from time to time, to prevent evaporation. Such a value is set upon the principal ingredient, called ta-feu, for manure, that the oldest and most helpless persons are not deemed wholly useless to the family by which they are supported. The quantity of manure collected by all means is still inadequate to the demand.

992. *Vegetable or wood ashes*, according to Livingstone, are esteemed the very best manure by the Chinese. The weeds which were separated from the land by the harrow, with what they otherwise are able to collect, are carefully burnt, and the ashes spread. The part of the field where this has been done is easily perceived by the most careless observer. Indeed the vigor of the productions of those parts of their land where the ashes have been applied is evident, as long as the crop continues on the ground. The ashes of burnt vegetables are also mixed with a great variety of other matters in forming the compositions which are spread on the fields, or applied to individual plants.

993. *The plaster of old kitchens* is much esteemed as a manure; so that a farmer will replaster a cook-house for the old plaster, that he may employ it to fertilize his fields.

994. *Of night-soil* (ta-feu), the Chinese have a high notion: and its collection and formation into cakes, by means of a little clay, clay and lime, or similar substances, gives employment to a great number of individuals. They transport these cakes to a great distance. This manure in its recent state is applied to the roots of cauliflowers, cabbages, and similar plants, with the greatest advantage.

995. *The dung and urine of all animals* is collected with great care; they are used both mixed and separately. The mixture is less valuable than the dung, and this for general purposes is the better, the older it is. Horns and bones reduced to powder, the cakes left after expressing several oils, such as of the ground-nut, hemp-seed, and the like, rank also as manures. Small crabs, the feathers of fowls and ducks, soot, the sweepings of streets, and the stagnant contents of common sewers, are often thought sufficiently valuable to be taken to a great distance, especially when water carriage can be obtained.

996. *Lime* is employed chiefly for the purpose of destroying insects; but the Chinese are also aware of its fertilizing properties.

997. *The Chinese often manure the plant rather than the soil.* The nature of the climate in the southern part of the empire seems to justify fully this very laborious but economical practice. Rain commonly falls in such quantities and force as to wash away all the soluble part of the soil, and the manure on which its fertility is supposed to depend; and this often appears to be so effectually done, that nothing meets the eye but sand and small stones. It is therefore proper that the Chinese husbandman should reserve the necessary nourishment of the plant to be applied at the proper time. For this purpose reservoirs of the requisite dimensions are constructed at the corner of every field, or other convenient places.

998. *With the seed or young plant its proper manure is invariably applied.* It is then carefully watered in dry weather night and morning, very often with the black stagnant contents of the common sewer; as the plants advance in growth the manure is changed in some instances more than once, till their advance towards maturity makes any further application unnecessary.

999. *The public retiring-houses* are described by Dr. Abel, as rather constructed for exposure than concealment, being merely open sheds with a railway, over the reservoir.

1000. *The mixture of soils* is said to be a common practice as a substitute for manure: "they are constantly changing earth from one piece of ground to another; mixing sand with that which appears to be too adhesive, and loam where the soil appears to be too loose, &c."

1001. *The terrace cultivation* is mentioned by Du Halde and others, as carried to great perfection in China; but the observations of subsequent travellers seem to render this doubtful. Lord Amherst's embassy passed through a hilly and mountainous country for many weeks together; but Dr. Abel, who looked eagerly for examples of that system of cultivation, saw none that answered to the description given by authors. Du Halde's description, he says, may apply to some particular cases; but the instances which he observed lead him to conclude that terrace cultivation is in a great measure confined to their ravines, undulations, and gentlest declivities.

1002. *Rows, or drills, are almost always adopted* in planting or sowing; and for this purpose the lands are laid flat, and not raised into ridges with intervening furrows. They are said to be particular in having the direction of their rows from north to south, which other circumstances being suitable is certainly a desirable practice. Before sowing, seeds are generally kept in liquid manure till they germinate. Barrow frequently saw in the province of Keang-see a woman drawing a light plough with a single handle (*fig. 156 a*), through ground previously prepared; while a man held the plough with one hand, and with the other cast the seed into the drills.

1003. *Forests of immense extent* exist on the mountains of the western districts of China, and abound in almost every species of tree known in Europe, and many others unknown. Besides timber and fuel, these forests supply many valuable products as



barks, gums, oils, and resins, used in the arts. Rosewood, ebony, sandalwood, ironwood, and a great variety of others are sent to Europe for cabinet work. The Chinese aloe has the height and figure of an olive tree. It contains within the bark three sorts of wood; the first, black, compact, and heavy, is called eagle-wood; it is scarce; the second, called calambooc, is light like rotten wood; the third, near the centre, is called calamba wood, and sells in India for its weight in gold; its smell is exquisite; it is an excellent cordial in cases of fainting, or of palsy.

1004. *The national agricultural fête* of the Chinese deserves to be noticed. Every year on the fifteenth day of the first moon, which generally corresponds to some day in the beginning of our March, the emperor in person goes through the ceremony of opening the ground; he repairs in great state to the field appointed for this ceremony. The princes of the imperial family, the presidents of the five great tribunals, and an immense number of mandarins attend him. Two sides of the field are lined with the officers of the emperor's house, the third is occupied by different mandarins; the fourth is reserved for all the laborers of the province, who repair thither to see their art honored, and practised by the head of the empire. The emperor enters the field alone, prostrates himself, and touches the ground nine times with his head in adoration of *Tien*, the God of heaven. He pronounces with a loud voice a prayer prepared by the court of ceremonies, in which he invokes the blessing of the Great Being on his labor, and on that of his whole people. Then, in the capacity of chief priest of the empire, he sacrifices an ox, in homage to heaven as the fountain of all good. While the victim is offered on the altar, a plough is brought to the emperor, to which is yoked a pair of oxen, ornamented in a most magnificent style. The prince lays aside his imperial robes, lays hold of the handle of the plough with the right hand, and opens several furrows in the direction of north and south; then gives the plough into the hands of the chief mandarins, who, laboring in succession, display their comparative dexterity. The ceremony concludes with a distribution of money, and pieces of cloth as presents, among the laborers; the ablest of whom execute the rest of the work in presence of the emperor. After the field has received all the necessary work and manure, the emperor returns to commence the sowing with similar ceremony, and in presence of the laborers. These ceremonies are performed on the same day by the viceroys of all the provinces.

SUBJECT. 9. *Present State of Agriculture in Chinese Tatar, Thibet, and Bootan.*

1005. *Chinese Tatar* is an extensive region, diversified with all the grand features of nature, and remarkable for its vast elevated plain, supported like a table, by the mountains of Thibet in the south, and Allusian chain in the north. This prodigious plain is little known; its climate is supposed to be colder than that of France; its deserts to consist chiefly of a black sand; and its agriculture to be very limited and imperfect. Wheat, however, is said to be grown among the southern Mandshurs.

1006. *Thibet or Tibet* is an immense tract of country little known. It consists of two divisions, *Thibet* and *Bootan*. The climate of Thibet is extremely cold and bleak towards the south, for though on the confines of the torrid zone it vies in this respect with the Alps of Italy. That of Bootan is more temperate; and the seasons of both divisions are severe to those of Bengal.

1007. *With respect to surface*, Bootan and Thibet exhibit a very remarkable contrast. Bootan presents to the view nothing but the most misshapen irregularities; mountains covered with eternal verdure, and rich with abundant forests of large and lofty trees. Almost every favorable aspect of them, coated with the smallest quantity of soil, is cleared and adapted to cultivation, by being shelved into horizontal beds: not a slope or narrow slip of land between the ridges lies unimproved. There is scarcely a mountain whose base is not washed by some rapid torrent, and many of the loftiest bear populous villages, amidst orchards and other plantations, on their summits and on their sides. It combines in its extent the most extravagant traits of rude nature and laborious art.

1008. *Thibet*, on the other hand, strikes a traveller, at first sight, as one of the least favored countries under heaven, and appears to be in a great measure incapable of culture. It exhibits only low rocky hills, without any visible vegetation, or extensive arid plains, both of the most stern and stubborn aspect, promising full as little as they produce.

1009. *The agriculture of Thibet* has many obstacles to contend with. Its common products are wheat, pease, and barley. Rice grows only in the southern parts. Turnips, pumpkins, and cucumbers are abundant. The greater part of the plants which travellers have noticed are such as are met with also in Europe and in Bengal. At the foot of the mountains are forests of bamboos, bananas, aspens, birches, cypresses, and yew-trees. The ash is remarkably large and beautiful, but the firs small and stunted. On the snow-clad mountains grows the rheum undulatum, which the natives use for medicinal purposes. The country contains, both in a wild and cultivated state, peaches and apricots, apples, pears, oranges, and pomegranates. The *caclia saracenic* serves for the manufacture of *chong*, a spirituous and slightly acid liquor.

1010. *Thibet abounds in animals, partly in herds and flocks; but chiefly in a wild state. The tame horses are small, but full of spirit and restive. The cattle are only of middling height. There are numerous flocks of sheep, generally of a small breed; their head and legs are black, their wool fine and soft, and their mutton excellent; it is eaten in a raw state, after having been dried in the cold air, and seasoned with garlic and spices. The goats are numerous, and celebrated for their fine hair, which is used in the manufacture of shawls; this grows under the coarser hair. The yak, or grunting ox, furnished with long and thick hair, and a tail singular for its silky lustre and undulating form, furnishes an article of luxury common in all the countries of the East. The musk ox, the ounce, a species of tiger, the wild horse, and the lion, are among the animals of the country.*

1011. *That elegant specimens of civil architecture, both in the construction of mansions (fig. 159.), or palaces, and in bridges and other public works, should be found in such a country is rather singular. In Turner's journey through this mountainous region, he found bridges of various descriptions generally of timber. Over broad streams, a triple or quadruple row of timbers project one over the other, their ends inserted into the rock. Piers are almost totally excluded, on account of the extreme rapidity of the rivers. The widest river has an iron bridge, consisting of a number of iron chains which support a matted platform (fig. 160.), and two chains are stretched*

159

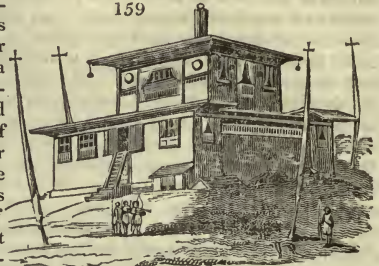

160

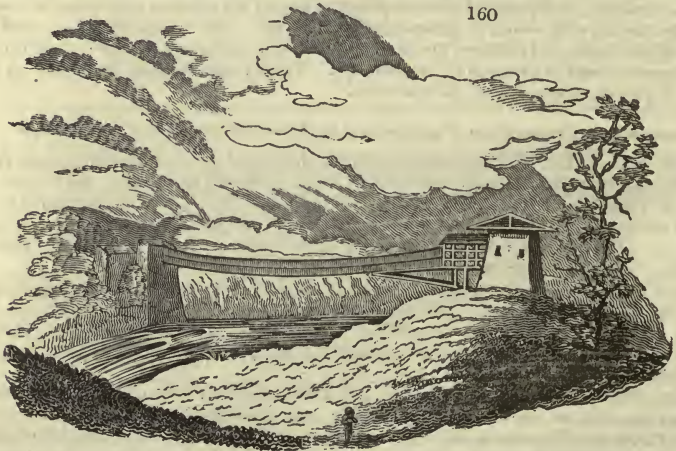

above parallel with the sides, to allow of a matted border for the safety of the passenger. Horses are permitted to go over this bridge, one at a time. There is another bridge of a more simple construction, formed of two parallel chains, round which creepers are loosely twisted, sinking very much in the middle, where suitable planks are placed for a path. Another mode of passing rivers is by two ropes, of rattan, or stout osier, stretched from one mountain to another, and encircled by a hoop of the same. The passenger places himself between them, sitting in the hoop, and seizing a rope in each hand, slides himself along with facility and speed over an abyss tremendous to behold. Chain and wire bridges, constructed like those of Thibet, are now becoming common in Britain; and it is singular, that one is described in Hutchinson's *Durham* (Newcast. 1785.) as having been erected over the Tees.

SUBJECT. 10. *Present State of Agriculture in the Asiatic Islands, including also those of Australasia and Polynesia.*

1012. *The islands of Asia and Australasia form a great and important part of our globe; and seem well adapted by nature for the support of civilized man, though at present they are mostly peopled by savages. Some European colonies have been made, especially in New Holland and Van Diemens Land, which will probably after a long and indefinite period, civilize the whole. The immense population, agriculture, commerce, power, and refinement, which may then exist in these scarcely known regions, are too vast and various*

for contemplation. We shall notice these islands in the order of Sumatra, Borneo, the Manillas, the Celebeian isles, New Holland, New Guinea, New Britain, New Zealand, Van Diemens Land, the Pelew isles, the Landrone isles, Caroline isles, Sandwich isles, the Marquesas, the Society isles, including Otaheite, and the Friendly isles.

1013. *Sumatra* is an island of great extent, with a climate more temperate than that of Bengal, a surface of mountains and plains, one-third of which is covered with impervious forests, and a soil consisting of a stratum of red clay, covered with a layer of black mould. The most important agricultural product is rice, which is grown both for home consumption and export. Next may be mentioned the cocoa-nut, the areca-palm, or betel nut tree, and the pepper. Cotton and coffee are also cultivated; and the native trees afford the resin benzoin, cassia or wild cinnamon, rattans or small canes (*Arundo rotang*), canes for walkingsticks, turpentine, and gums; besides ebony, pine, sandal, teak, manchineel, iron wood, banyan, aloe, and other woods.

1014. *The pepper plant* (*Piper nigrum*, fig. 161 a.) is a slender climbing shrub, which also roots at the joints. It is extensively cultivated at Sumatra, and the berries exported to every part of the world. According to Marsden (*Hist. of Sumatra*), the ground chosen by the Sumatrans for a pepper-garden, is marked out into regular squares of six feet, the intended distance of the plants, of which there are usually a thousand in each garden. The next business is to plant the chinkareens, which serve as props to the pepper-vines, and are cuttings of a tree of that name, which is of quick growth. When the chinkareen has been some months planted, the most promising perpendicular shoot is reserved for growth, and the others lopped off: this shoot, after it has acquired two fathoms in height, is deemed sufficiently high, and its top is cut off. Two pepper-vines are usually planted to one chinkareen, round which the vines twist for support; and after being suffered to grow three years (by which time they acquire eight or twelve feet in height), they are cut off about three feet from the ground, and being loosened from the prop, are bent into the earth in such a manner that the upper end is returned to the root. This operation gives fresh vigor to the plants, and they bear fruit plentifully the ensuing season. The fruit, which is produced in long spikes, is four or five months in coming to maturity: the berries are at first green, turn to a bright red when ripe and in perfection, and soon fall off if not gathered in proper time. As the whole cluster does not ripen at the same time, part of the berries would be lost in waiting for the latter ones; the Sumatrans, therefore, pluck the bunches as soon as any of the berries ripen, and spread them to dry upon mats, or upon the ground; by drying they become black, and more or less shrivelled, according to their degree of maturity. These are imported here under the name of *black pepper*.



1015. *White pepper* is the ripe and perfect berries of the same species stripped of their outer coats. For this purpose the berries are steeped for about a fortnight in water, till by swelling their outer coverings burst; after which they are easily separated, and the pepper is carefully dried by exposure to the sun; or the berries are freed from their outer coats by means of a preparation of lime and mustard-oil, called "chinam," applied before it is dried. Pepper, which has fallen to the ground over-ripe, loses its outer coat, and is sold as an inferior sort of white pepper.

1016. *The betel leaf* (*Piper betle*, fig. 161 b.) is also cultivated to a considerable extent. It is a slender-stemmed climbing or trailing plant, like the black pepper, with smooth-pointed leaves. These leaves serve to enclose a few slices of the nut of the areca palm (erroneously called the *betel nut*). The areca being wrapped up in the leaf, the whole is covered with a little chunam or shell-lime to retain the flavor. The preparation has the name of betel, and is chewed by the better sort of southern Asiatics to sweeten the breath and strengthen the stomach; and by the lower classes, as ours do tobacco, to keep off the calls of hunger. The consumption is very extensive.

1017. *The areca palm* (*Areca catechu*) grows to the height of forty or fifty feet with a straight trunk, and is cultivated in the margins of fields for its nut or fruit, which is sold to prepare betel.

1018. *Three sorts of cotton are cultivated*, including the silk cotton (*Bombax ceiba*), a handsome tree, which has been compared by some to a dumb waiter, from the regularity of its branches.

1019. *The live stock of Sumatra* are horses, cows, buffaloes, sheep, and swine. They are all diminutive. The horse is chiefly used for the saddle, and the buffalo for labor. The wild animals are numerous, and include the civet cat, monkey, argus pheasant, the jungle or wild fowl, and the small breed found also at Bantom on the west of Java, and well known in Britain by that name.

1020. *Borneo* is the largest island in the world next to *New Holland*. It is low and marshy towards the shore, and in this respect and in its climate, is similar to *Java*. The soil is naturally fertile; but agriculture is neglected, the inhabitants occupying themselves in searching for gold, which they exchange with the Japanese for the necessaries of life.

1021. *The ava*, or *intoxicating pepper* (*Piper methysticum*), is cultivated here. It is a shrub with a forked stem and oblong leaves, bearing a spike of berries, and having thick roots. The root of this plant, bruised or chewed in the mouth, and mixed with the saliva, yields that nauseous, hot, intoxicating juice, which is so acceptable to the natives of the South Sea islands, and which is spoken of with so much just detestation by voyagers. A similar drink is made in *Peru* from the meal of the maize. They pour the liquor of the cocoa-nut, or a little water, on the bruised or masticated matter, and then a small quantity produces intoxication and sleep. After the use of it for some time, it produces inflammation, leprous ulcers, and consumption. It is cultivated in all the South Sea islands, excepting the *New Hebrides* and *New Caledonia*. (*Spix's Travels*.)

1022. *The Manillas*, or *Philippine Islands*, are a numerous group, generally fruitful in rice, cotton, the sugar-cane, and cocoa. The bread-fruit also begins to be cultivated here.

1023. *The Celebezan Islands* are little known. They are said to abound in poisonous plants; and the inhabitants cultivate great quantities of rice.

1024. *The Moluccas*, or *Spice Islands*, are small, but fertile in agricultural products. In none the bread-fruit is cultivated, also the sago palm, with cloves and nutmegs. The nutmeg-tree (*Myristica moschata*) grows to the size of a pear-tree, with laurel-like leaves; it bears fruit from the age of ten to one hundred years. The fruit is about the size of an apricot, and when ripe nearly of a similar color. It opens and discovers the mace of a deep red, growing over and in part covering the thin shell of the nutmeg, which is black. The tree yields three crops annually; the first in April, which is the best; the second in August; and the third in December; yet the fruit requires nine months to ripen it. When it is gathered, the outer coriaceous covering is first stripped off, and then the inner carefully separated and dried in the sun. The nutmegs in the shell are exposed to heat and smoke for three months, then broken, and the kernels thrown into a strong mixture of lime and water, which is supposed to be necessary for their preservation, after which they are cleaned and packed up; and with the same intention the mace is sprinkled with salt water.

1025. *New Holland*, or what may be called the continent of *Australasia*, has a fine and salubrious climate; and being on the southern side of the equator, the seasons are the reverse of those in *Europe*. The surface is in general low and level, and little occupied by mountains. The country is naturally rather barren than fertile; the soil is sandy, and many of the lawns or savannahs are rocky and barren. Woods occur frequently, but there appear to be few or none of those extensive forests which cover such immense tracts in most new countries. The inhabitants being savages of the lowest grade, have no kind of agriculture or cultivation. That art, however, is making rapid progress round the *British colony of Botany Bay*.

1026. *Papua*, or *New Guinea*, partakes of the opulence of the *Moluccas*, and their singular varieties of plants and animals. The coasts are lofty, and abound with cocoa-trees; in the interior, mountain rises above mountain, richly clothed with woods of great variety of species, and abounding in wild swine (fig. 162.) Birds of paradise and elegant parrots abound: they are shot with blunt arrows, or caught with bird-lime or nooses. The bowels and breast being extracted, they are dried with smoke and sulphur, and sold for nails or bits of iron to such navigators as touch at the island.

1027. *New Britain*, *New Ireland*, the *Solomon Isles*, *New Caledonia*, and the *New Hebrides*, are little known. They are mountainous and woody, with fertile vales and beautiful streams. The nutmeg, cocoa, yam, ginger, pepper, plantains (fig. 163.) sugar-canes, and other fruits and spice-trees abound.

1028. *New Zealand* has scarcely any agriculture; but plantations of yam, cocoa, and sweet potatoe. There is only one shrub or tree in this country which produces fruit, and that is a kind of a berry almost tasteless; but they have a plant (*Phormium tenax*), which answers all the uses of hemp and flax. There are two kinds of this plant; the leaves of one of which are yellow, and the other deep red; and both of them resemble the leaves of flax; of these leaves they make



lines and cordage, and much stronger than any thing of the kind in Europe. These leaves they likewise split into breadths, and tying the slips together, form their fishing-nets. Their common apparel, by a simple process, is made from these leaves; and their finer, by another preparation, is made from the fibres. This plant is found both on high and low ground, in dry mould and deep bogs; but as it grows largest in the latter, that seems to be its proper soil. It has lately been planted, and found to prosper, in the south of Ireland.

1029. *Van Diemens Land* is without indigenous agriculture; but its climate being similar to that of England, its surface and soil favorable for culture, and there being few natives, it is rapidly colonizing with British farmers. As a country to emigrate to, it appears the most desirable in Australasia, and superior to any in Asia.

1030. *The Pellow Isles* are covered with wood, and encircled by a coral reef. None of these islands have any sort of grain or quadruped; but they are rich in the most valuable fruit and spice trees, including the cabbage-tree (*Areca oleracea*, fig. 164.), cocoa, plantain, and orange; and abound with wild cocks and hens, and many other birds. The culture of the natives only extends to yams and cocoa-nuts.

1031. *The Ladrones* are a numerous collection of rocky fragments, little adapted to agriculture. The isles of Guam and Tinian are exceptions. The latter abounds in cattle and fruits, the bread-fruit, and orange; but is without agriculture.

1032. *The Carolines* are a large group, inhabited by savages, and without agriculture.

1033. *The Marquesas* are in general rocky and mountainous, and but very few spots are fit for cultivation. The inhabitants are savages, but cultivate rudely the yam in some places. They have, however, the ava, or intoxicating pepper (1021.); and procure also a strong liquor from the root of ginger for the same general purpose of accumulating enjoyment, forgetting care, and sinking into profound sleep.

1034. *The Sandwich Isles* resemble those of the West Indies in climate, and the rest of the South Sea islands in vegetable productions. The bread-fruit tree attains great perfection. Sugar-canes grow to an unusual size, one being brought to Captain Cook eleven and a quarter inches in circumference, and having fourteen feet eatable. Dogs, hogs, and rats, are the only native quadrupeds of these islands, in common with all others that have been discovered in the South Sea. The king is a civilized being, and in the time of Geo. II., and again in 1824, visited England.

1035. *The island of Otaheite* is surrounded by a reef of coral rocks. The surface of the country, except that part of it which borders upon the sea, is very uneven; it rises in ridges, that run up into the middle of the island, and there form mountains, which may be seen at the distance of sixty miles: between the foot of these ridges and the sea is a border of low land, surrounding the whole island, except in a few places where the ridges rise directly from the sea: the border of low land is in different parts of different breadths, but no where more than a mile and a half.

1036. *The soil of Otaheite*, except on the very tops of the ridges, is extremely rich and fertile, watered by a great number of rivulets of excellent water, and covered with fruit-trees of various kinds. The low land that lies between the foot of the ridges and the sea, and some of the valleys, are the only parts of the island that are inhabited, and here it is populous: the houses do not form villages or towns, but are ranged along the whole border, at the distance of about fifty yards from each other, with little plantations of plantains, the tree which furnishes them with cloth.

1037. *The produce of Otaheite* is the bread-fruit, (*Artocarpus integrifolia*, fig. 165.) cocoa-nuts, bananas of thirteen sorts, plantains, a fruit not unlike an apple, which, when ripe, is very pleasant; sweet potatoes, yams, cocoas (*Arum colocassia*, and *Caladium esculentum*, both propagated by the leaves); a fruit known here by the name of jambu, and reckoned most delicious; sugar-cane, which the inhabitants eat raw; a root of



the saloop kind, which the inhabitants call pea; a plant called ethee, of which the root only is eaten; a fruit that grows in a pod, like that of a large kidney bean, which, when it is roasted, eats very much like a chestnut, by the natives called whee; a tree called wharra, called in the East Indies pandanes, which produces fruit something like the pine apple; a shrub called nono; the morinda, which also produces fruit; a species of fern, of which the root is eaten, and sometimes the leaves: and a plant called theve, of which the root also is eaten: but the fruits of the nono, the fern, and the theve, are eaten only by the inferior people, and in times of scarcity: all these, which serve the inhabitants for food, the earth produces spontaneously, or with little culture. They had no European fruit, gardenstuff, pulse, or legumes, or grain of any kind, till some seeds of melons and other vegetables were given them by Captain Cook.

1038. *Of tame animals*, the Otaheitans have only hogs, dogs, and poultry; neither is there a wild animal in the island, except ducks, pigeons, parrots, with a few other birds, and rats, there being no other quadruped, nor any serpent. But the sea supplies them with great variety of most excellent fish, to eat which is their chief luxury, and to catch it their principal labor.

1039. *The Friendly Islands* are in most respects similar to Otaheite. Tongataboo appears to be a flat country, with a fine climate, and universally cultivated. The whole of this island is said to consist of enclosures, with reed fences about six feet high, intersected with innumerable roads. The articles cultivated are bread fruit, plantains, cocoa-nuts, and yams. In the other islands, plantains and yams engage most of their attention; the cocoa-nut and bread fruit-trees are dispersed about in less order than the former, and seem to give them no trouble. Their implements of culture consist of pointed sticks of different lengths and degrees of strength.

## SECT. II. *Present State of Agriculture in Africa.*

1040. *The continent of Africa* in point of agricultural, as of political and ethical estimation, is the meanest of the great divisions of the earth; though in one corner of it (Egypt) agriculture is supposed to have originated. The climate is every where hot, and intensely so in the northern parts. The central parts, as far as known, consist of ridges of mountains and immense deserts of red sand. There are very few rivers, inland lakes, or seas, and indeed fully one half of the whole of this continent may be considered as either desert, or unknown. Some of the African islands are fertile and important, especially Madagascar, Bourbon, Mauritias, &c. We shall take the countries of Africa in the order of Abyssinia, Egypt, Mahometan states of the north, western coast, Cape of Good Hope, eastern coast, Madagascar, and other isles.

### SUBSECT. 1. *Present State of Agriculture in Abyssinia.*

1041. *The climate of Abyssinia*, though exceedingly various in different parts, is in general temperate and healthy. The surface of the country is generally rugged and mountainous; it abounds with forests and morasses; and it is also interspersed with many fertile valleys and plains, that are adapted both to pasture and tillage. The rivers are numerous and large, and contribute much to general fertility. The soil is not naturally good, being in general thin and sandy; but it is rendered fertile and productive by irrigation and the periodical rains.

1042. *The agricultural products* are wheat, barley, millet, and other grains. They cultivate the vine, peach, pomegranate, sugar-cane, almonds, lemons (fig. 166.), citrons, and oranges; and they have many roots and herbs which grow spontaneously, and their soil, if properly managed, would produce many more. However, they make little wine, but content themselves with the liquor which they draw from the sugar-cane, and their honey, which is excellent and abundant. They have the coffee-tree, and a plant called ensete, which produces an eatable nou-

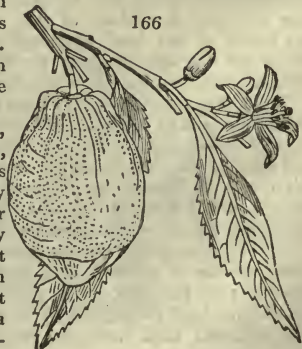

rishing fruit. The country also produces many other plants and fruits, that are adapted both for domestic and medicinal uses. Here is plenty of cotton, which grows on shrubs, like the Indian. Their forests abound with trees of various descriptions, particularly the rock, baobab, cedar, sycamore, &c.

1043. *The live stock* of Abyssinia includes horses, some of which are of a very fine breed; mules, asses, camels, dromedaries, oxen of different kinds, (fig. 167.) cows, sheep, and goats; and these constitute the principal wealth of the inhabitants. Amongst the wild animals, we may reckon the antelope, the buffalo, the wild boar, the jackal, the elephant, the rhinoceros, the lion, the leopard, the hyæna, the lynx, ape, and baboon, which are very destructive to the fields of millet, as well as the common rat; the zecora, or wild mule, and the wild ass; the jërboa, the fennic, ashkoko, hare, &c. The hare, as well as the wild boar, is deemed unclean, and not used as food. Bruce saw no sparrows, magpies, nor bats; nor many water-fowl, nor any geese, except the golden goose, or goose of the Nile, which is common in every part of Africa; but there are snipes in the marshes. The locusts of this country are very destructive; they have also a species of ants, that are injurious; but from their bees they derive a rich supply.



1044. *The agriculture of Abyssinia* is of far less use to the inhabitants than it might be for want of application and exertion. There are two, and often three harvests in the year; and where they have a supply of water, they may sow in all seasons; many of their trees and plants retain their verdure, and yield fruit or flowers throughout the year; the west side of a tree blossoms first, and bears fruit, then the south side, next the north side, and last of all the east side goes through the same process towards the beginning of the rainy seasons. Their pastures are covered with flocks and herds. They have grass in abundance, but they neglect to make hay of it; and therefore they are obliged to supply this defect by feeding their cattle with barley, or some other grain. Notwithstanding the plenty, and frequent return of their crops, they are sometimes reduced almost to famine, either by the devastations of the locusts or grasshoppers which infest the country, or by the more destructive ravages of their own armies, and those of their enemies.

#### SUBJECT. 2. *Present State of Agriculture in Egypt.*

1045. *The climate of Egypt* has a peculiar character from the circumstance of rain being very uncommon. The heat is also extreme, particularly from March to November; while the cool season, or a kind of spring, extends through the other months.

1046. *The surface of the country* is varied in some regions, but is otherwise flat and uniform. Far the greater part presents a narrow fertile vale, pervaded by the Nile, and bounded on either side by barren rocks and mountains. The soil of Egypt has been variously described by different travellers, some representing it as barren sand, only rendered fertile by watering, and others as "a pure black mould, free from stones, of a very tenacious and unctuous nature, and so rich as to require no manure." The latter appears to prevail only in the Delta.

1047. *The fertility of Egypt* has been generally ascribed to the inundations of the Nile, but this is applicable in a strict sense only to parts of the Delta; whereas, in other districts there are canals, and the adjacent lands are generally watered by machines. Gray's description of Egypt, as immersed under the influx of the Nile, though exquisitely poetical, is far from being just. In Upper Egypt the river is confined by high banks, which prevent any inundation into the adjacent country. This is also the case in Lower Egypt, except at the extremities of the Delta, where the Nile is never more than a few feet below the surface of the ground, and where of course inundation takes place. But the country, as we may imagine, is without habitations. The fertility of Egypt, according to Browne, an intelligent traveller, arises from human art. The lands near the river are watered by machines; and if they extend to any width, canals have been cut. The soil in general is so rich as to require no manure. It is a pure black mould, free from stones, and of a very tenacious unctuous nature. When left uncultivated, fissures have been observed, arising from extreme heat, of such depth that a spear of six feet could not reach the bottom.

1048. *The limits of cultivated Egypt* are encroached upon annually, and barren sand is accumulating from all parts. In 1517, the era of the Turkish conquest, lake Marcotis was at no distance from the walls of Alexandria, and the canal which conveyed the waters into the city was still navigable. At this day the lake has disappeared, and the lands

watered by it, which, according to historians, produced abundance of corn, wine, and various fruits, are changed into deserts, in which are found neither shrub, nor plant, nor verdure. The canal itself, the work of Alexander, necessary to the subsistence of the inhabitants of the city, which he built, is nearly choked up, and preserves the waters only when the inundation is at its greatest height, and for a short time. About half a century ago, part of the mud deposited by the river was cleared out of it, and it retained the water three months longer. Schemes have lately been adopted for opening and perfecting this canal. The Pelusiatic branch, which discharges itself into the eastern part of the lake of Tanais, or Menzalé, is utterly destroyed. With it perished the beautiful province which it fertilized, and the famous canal begun by Necos, and finished by Ptolemy Philadelphus. The famous works executed by kings, who sought their glory and happiness in the prosperity of the people, have not been able to resist the ravages of conquerors, and that despotism, which destroys every thing, till it buries itself under the wreck of the kingdoms whose foundation it has sapped. The canal of Amrou, the last of the great works of Egypt, and which formed a communication between Fostat and Colzoum, reaches at present no farther than about four leagues beyond Cairo, and loses itself in the lake of Pilgrims. Upon the whole, it may be confidently affirmed that upwards of one-third of the lands formerly in cultivation is metamorphosed into dreary deserts.

1049. *Landed property in Egypt* is for the most part to be considered as divided between the government and the religious bodies, who perform the service of the mosques, and have obtained possession of what they hold by the munificence of princes and rich men, or by the measures taken by individuals for the benefit of their posterity. Hence, a large proportion of the tenants and cultivators hold either of the government, or the procurators of the mosques. But there is one circumstance common to both, viz. that their lands, becoming unoccupied, are never let but upon terms ruinous to the tenants. Besides the property and influence of the beys, the mamelukes and the professors of the law are so extensive, and so absolute, as to engross into their own hands a very considerable part: the number of the other proprietors is extremely small, and their property liable to a thousand impositions. Every moment some contribution is to be paid, or some damage repaired; there is no right of succession or inheritance for real property, except for that called "wakf," which is the property of the mosques; every thing returns to government, from which every thing must be repurchased. According to Volney, the peasants are hired laborers, to whom no more is left than what is barely sufficient to sustain life; but Browne says, that these terms can be properly applied to very few of them.

1050. *The occupier of the land*, assisted by his family, is the cultivator; and in the operations of husbandry scarcely requires any other aid. And the tenant of land commonly holds no more than he and his family can cultivate, and gather the produce of. When, indeed, the Nile rises, those who are employed to water the fields are commonly hired laborers. The rice and corn they gather are carried to their masters, and nothing is reserved for them but dourra, or Indian millet, of which they make a coarse and tasteless bread without leaven; this, with water and raw onions, is their only food throughout the year; and they think themselves happy if they can sometimes procure a little honey, cheese, sour milk, and dates. Their whole clothing consists in a shirt of coarse blue linnen, and in a black cloak. Their head-dress is a sort of cloth bonnet, over which they roll a long handkerchief of red woollen. Their arms, legs, and breasts are naked, and some of them do not even wear drawers. Their habitations (fig. 168.) are mud-walled huts, in which they are suffocated with heat and smoke, and in which, besides the experience of other inconveniences, they are perpetually distressed with the dread of the robberies of the Arabs, and the extortions of the mamelukes, family feuds, and all the calamities of a perpetual civil war.

1051. *The agricultural products of Egypt* are grain of most sorts, and particularly rice. Barley is grown for the horses, but no oats are seen. In the Delta a crop of rice and a crop of barley are obtained within the year on the same ground. Sometimes instead of barley a fine variety of the soil (*Trifolium Alexandrinum* of Forskal) is sown without ploughing or harrowing. The seed sinks to a sufficient depth in the moist soil, and produces three cuttings before the time for again sowing the rice.

1052. *Rice* is sown from the month of March to that of May; and is generally six months in coming to maturity. In reaping, it is most commonly pulled up by the roots; and as the use of the flail is unknown in Egypt, the rice plants are spread in thick layers on floors, formed of earth and pigeon's dung, which are well beaten, and very clean; and then, in order to separate the grain from the straw, they make use of a sort of carts, constructed like our sledges, with two pieces of wood joined together by two cross bars; between the longer sides of this sledge are fixed transversely three rows of small wheels, made of solid iron, and narrowed off towards their circumference. On the fore part is fixed a high seat, on which a man sits, for the purpose of driving two oxen that are harnessed to the machine, and thus moving it in a





circular direction over every part of the heap of rice, till the grain is completely separated from the straw; the grain is then spread in the air to be dried. The dried rice is carried to the mill, where it is stripped of its chaff or husk. This mill consists of a wheel turned by oxen, which sets several levers in motion; and at their extremity is an iron cylinder, about a foot long, and hollow underneath; these cylinders bent in troughs, which contain the grain; and at the side of each trough there stands a man, whose business it is to place the rice under the cylinders. The next operation is to sift the rice in the open air, by filling a small sieve, which a man lifts over his head, and thus lets fall, with his face turned to the wind, which blows away the small chaff or dust. This cleaned rice is put a second time into the mill, in order to bleach it; it is afterwards mixed up in troughs with some salt, which contributes very much to its whiteness, and also to its preservation; and in this state it is sold. Rice is furnished in great quantities in the Delta; and that which is grown in the environs of Rosalta is more esteemed on account of its preparation, than that which is produced in the vicinity of Damietta. The produce of the one and the other is equally wonderful. In a good season, that is, when the rise of the Nile occasions a great expansion of its waters, the profit of the proprietors of rice fields is estimated at fifty per cent. clear of all expenses. Savary says, that it produces eighty bushels for one.

1053. *Wheat* is sown as soon as the waters of the Nile have retired from the lands appropriated to it; the seed-time varies with the latitude, and also the harvest, which is earlier in Upper than in Lower Egypt. Near to Syene they sow the barley and the corn in October, and reap it in January. Towards Girge they cut in February, and in the month of March in the vicinity of Cairo. This is the usual progress of the harvest in the Said. There is also a number of partial harvests, as the lands are nearer or at a greater distance from the river, lower or more elevated. In the Lower Egypt they are sowing and reaping all the year. Where the waters of the river can be procured, the earth is never idle, and furnishes three crops annually. In descending from the cataracts in January, the corn is seen almost ripe; lower down it is in ear, and advancing further, the plains are covered with verdure. The cultivator, in general, merely casts the seed upon the moistened earth; the corn soon springs up from the mud; its vegetation is rapid, and four months after it is sown it is fit to be reaped. In performing this operation, the sickle not being used, the stalks are pulled up by the roots, and carried to large floors, like those which are used for treading out rice; and by a similar operation the corn is separated from the ear. Unripe ears of corn are dried and slacked baked in an oven, and being afterwards bruised and boiled with meat, form a common dish in Lower Egypt, called "ferik."

1054. *Flax* has been cultivated in Egypt from the most remote period, and is still grown in considerable quantities. Indigo is also grown for dyeing it, the color of the shirt in this country being universally blue.

1055. *Of the hemp*, which is abundantly cultivated in this country, the inhabitants prepare intoxicating liquors; and also by pounding the fruits into thin membranous capsules, they form a paste, which answers a similar purpose; and they also mix the capsules with tobacco for smoking.

1056. *The sugar-cane* is also one of the valuable productions of Egypt. The common people do not wait for the extraction of the sugar, but cut the canes green, which are sold in bundles in all the towns. They begin to ripen in October, but are not in general fit to be cut till November or December. The sugar-refiners are in a very imperfect state.

1057. *Fruit trees of various species* abound in this country. Among these we may reckon the olive-tree, fig-trees which yield figs of an exquisite flavor, and the date-tree, which is to be found every where in the Thebais and in the Delta, in the sands as well as in the cultivated districts, requiring little or no culture, and yielding a very considerable profit, on account of the immense consumption of its fruit. The species of palm-tree that furnishes dates produces also a bark; which, together with its leaves and the rind of its fruit, afford filaments from which are manufactured ropes and sails for boats. The leaves are also used for making baskets and other articles. The very long rib of the branches is employed, on account of its lightness and solidity, by the mamelukes, in their military exercises, as javelins, which they throw at each other from their horses when at full speed. A species of cyperus, which produces a fruit resembling the earth-nut, but of a much more agreeable flavor, is cultivated in the environs of Rosetta; and the small tubercles are sent to Constantinople and other towns of the Levant, where they are much valued. The Egyptians press from them a milky juice, which they deem pectoral and emollient; and give them to nurses; in order to increase the quantity of their milk. The banana trees, though not natives of the soil of Egypt, are nevertheless cultivated in the northern parts of that country. The papaw, or custard apple-tree, (*Anona*), is also transplanted into the gardens of Egypt, and yields a fruit equally gratifying to the taste and smell. In the shade of the orchards are cultivated various plants, the roots of which are refreshed by the water that is conveyed to them by little trenches; each enclosure having its well or reservoir, from which the water is distributed by a wheel, turned by oxen. The mallow (*Malva rotundifolia*) grows here in abundance: it is dressed with meat, and is one of those herbs that are most generally consumed in the kitchens of Lower Egypt. Two other plants used as food, are the garden jew's mallow, and the esculent hibiscus. Another tree, which appears to be indigenous in this country, is the "ate," a species of larger tamarisk (*Tamarix orientalis*, Forskal.) The wood of this tree serves for various purposes; and among others, for charcoal. It is the only wood that is common in Egypt, either for fuel or for manufactures. Fenu-greek is cultivated for fodder, though for this use a plant called barsim, is preferred. The plant called "helbe," is cried about for sale in November in the streets of the towns; and it is purchased and eaten with incredible avidity, without any kind of seasoning. It is pretended, that it is an excellent stomachic, a specific against worms and the dysentery, and, inshort, a preservation against a great number of disorders. Lentils form a considerable article of food to the inhabitants of Upper Egypt, who rarely enjoy the luxury of rice. The Egyptian onions are remarkably mild, more so than the Spanish, but not so large. They are of the purest white, and the lamina are of a softer and looser texture than that of any other species. They deteriorate by transplantation; so that much must depend on the soil and climate. They remain a favorite article of food with all classes; and it is usual to put a layer or two of them, and of meat, on a spit or skewer, and thus roast them over a charcoal fire. We need not wonder at the desire of the Israelites for the onions of Egypt. Leeks are also cultivated and eaten in this country; and almost all the species of European vegetables abound in the gardens of Rosetta. Millet and Turkey corn, the vine, the henné or Egyptian pivet, the water-melon (fig. 169.) are cultivated in Egypt;



and the country furnishes a variety of medicinal plants, as carthamus, tinctorius (fig. 170.), senna, coloquintida, &c., and that curious rooted plant the mandrake (fig. 171.) must at least be a native of the island of Canaan.

1058. *The live-stock of Egyptian agriculture is principally the ox, the buffalo, the horse, ass, mule, and camel. The oxen of Egypt are employed in tillage, and in giving motion to a variety of hydraulic machines; and as they are harnessed so as to draw from the pitch of the shoulder, their withers are higher than those of our country; and, indeed, they have naturally some resemblance to the bison (*Bos ferus*), or hunched ox. It has been said that the cows of Egypt bring forth two calves at a time; an instance of fecundity which sometimes happens; but is not reckoned very common. Their calves are reared to maturity, as veal, which is forbidden by the law of the Mahometans, and the Copts also abstain from the use of it, is not eaten in Egypt.*

1059. *The buffalo is more abundant than the ox, and is equally domestic. It is easily distinguishable by the constantly uniform colour of the hair, and still more by a remnant of ferocity and intractability of disposition, and a wild lower-*

*ing aspect, the characteristics of all half-tamed animals. The females are reared for the sake of the milk, and the males to be slaughtered and eaten. The flesh is somewhat red, hard, and dry; and has also a musky smell, which is rather unpleasant.*

1060. *The horses of Egypt rank next to those of the Arabians, and are remarkable for their valuable qualities. Here, as in most countries of the East, they are not castrated either for domestic use or the cavalry.*

1061. *The asses of Egypt have no less a claim to distinction than the horses; and these, as well as those of Arabia, are esteemed for their vigor and beauty the finest in the world. They are sometimes sold for a higher price than even the horses. They are more hardy than horses, less difficult as to the quality and quantity of their food, and are therefore preferred in traversing the deserts. The handsomest asses seen at Cairo are brought from Upper Egypt and Nubia. On ascending the Nile, the influence of climate is perceptible in these animals, which are most beautiful in the Said, but are in every respect inferior towards the Delta. With the most distinguished race of horses and asses, Egypt possesses also the finest mules; some of which, at Cairo, exceed in value the price of the most beautiful horses.*

1062. *The camel and dromedary, as every body knows, are the beasts of burden in Egypt, and not only answer all the purposes of our waggons and public conveyances, but bear the conveyances of luxury (fig. 172.), in which the females of the higher classes pay their visits on extraordinary occasions.*



171



172



1063. *The agricultural implements of Egypt* are simple; but some of them, particularly the contrivances for raising water, very ingenious. The plough is of the rudest kind, as are the cart and spade.

1064. *The operations of threshing and sowing* have been already described (1052-3.). That of irrigation is performed as in other countries. At present there are reckoned eighty canals in use for this purpose, some of them twenty, thirty, and forty leagues in length. The lands near the river, as the Delta, are watered directly from it; the water is raised by wheels in the dry season; and when the inundation takes place, it is retained on the fields for a certain time by small embankments made round them.

1065. *Nubia, the Ethiopia of the ancients*, is a miserable country or desert, thinly inhabited by a wretched people, who live chiefly on millet, and dwell in groups of mud huts, (fig. 173.)



SUBJECT. 3. *Present State of Agriculture in the Mahometan States of the North of Africa.*

1066. *These are Tripoli, Tunis, Algiers, and Morocco*; territories chiefly on the southern shore of the Mediterranean, rich, and celebrated in the ages of antiquity, but at present depressed by the barbarism and fanaticism of their rulers, who are in general tributary to the Porte.

1067. *Tripoli* is generally distinguished into maritime and inland. In neither is there much agriculture, for the inhabitants of countries on the coast live chiefly by commerce and piracy; and those of the inland parts on plunder and robbery. There are a few fields of grain, chiefly rice, round the capital, date palms, olives, and what is called the lotus-tree (*Zizyphus lotus*), whose fruit is reckoned superior to the date, and makes excellent wine.

1068. *The kingdom of Tunis* was formerly the chief seat of Carthaginian power. The soil is in general impregnated with marine salt and nitre, and springs of fresh water are more rare than of salt. But the Tunisians are much more agriculturists than their neighbors either of Tripoli or Algiers. The southern parts of the country are sandy, barren, and parched by a burning sun: the northern parts enjoy a better soil and temperature, and are more under cultivation: near the sea, the country is rich in olive-trees. The western part abounds in mountains and hills, and is watered by numerous rivulets; it is extremely fertile, and produces the finest and most abundant crops. The first rains commonly fall in September, and then the farmers break up the ground, sow their grain, and plant beans, lentils, and garvancos. By May following, harvest commences; and we may judge of its productiveness by what the Carthaginians experienced of old (38.) The ox and the buffalo are the principal beasts of labor, and next the ass, mule, and horse. Both the first and the last have here degenerated in size. They have a curiously-shaped cow (fig. 174.), which some consider a distinct species from the *bos taurus*, fœm. or common cow.

1069. *The territory of Algiers*, in an agricultural point of view, is chiefly distinguished by the fertile plain of Mettjiah, a vast country, which stretches fifty miles in length, and twenty in breadth, to the foot of one of the branches of Mount Atlas. This plain is watered by several streams; the soil is light and fertile, and it is better cultivated than any other district of the kingdom. The country-seats and masharcas, as they call the farms of the principal inhabitants of Algiers, are found in these plains; and it is chiefly from them that the metropolis is supplied with provisions. Flax, alhenna, roots, potherbs, rice, fruit, and grain of all kinds are produced here to such perfection, that the garden of the whole kingdom.

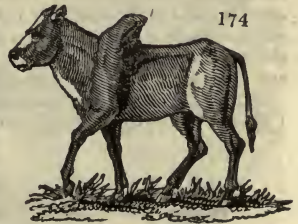

1070. *In the inland provinces* are immense tracts of country wholly uninhabited and uncultivated. There are also extensive tracts of brushwood, and some timber-forests. The fertility of the soil decreases in approaching Sahara or the Desert, although in its borders, and even in the desert itself there are some districts which are capable of cultivation, and which produce corn, figs, and dates. These regions are inhabited by nomadical tribes, who, valuing themselves on their independence, endure with fortitude and resignation the inconveniences attending their condition, and scarce regret the want of those advantages and comforts that pertain to a civilised state of society.

1071. *The seed-time* here, as in Tunis, is during the months of October and November, when wheat, barley, rice, Indian corn, millet, and various kinds of pulse, are sown. In six months, the crops are harvested, trod out by oxen or horses, winnowed by throwing with a shovel against the wind, and then lodged in subterraneous magazines.

1072. *The empire of Morocco* is an extensive territory of mountains and plains, and chiefly an agricultural country. The mountains consist of limestone or clay, or a mixture of both, and no vestiges appear of granite, on which they are supposed to rest. The climate is temperate and salubrious, and not so hot as its situation would lead us to suppose. The rains are regular in November, though the atmosphere is not loaded with clouds: January is summer; and in March barley-harvest commences. The soil consists either of pure sand, often passing into quicksand, or of pure clay; often so abundantly mixed with iron ochre, that agricultural productions, such as wax, gum, wool, &c. are distinguished by a reddish tint, which, in the wool, cannot be removed by washing or bleaching. Cultivation, in this country, requires little labor, and, in general, no manure; all other weeds and herbaceous plants, not irrigated, are, at a certain season, burnt up by the sun, as in some parts of Spain (696.); the ground being then perfectly clean and dry, is rendered friable, and easily pulverised by the rains; and one rude stirring suffices both for preparing the soil and covering the seed. The produce in wheat, rice, millet, maize, barley, chick-peas (*Cicer arietinum*), is often sixty fold; thirty fold is held to be an indifferent harvest.

1073. *In general* they make use of no manure, except that which is left on the fields by their flocks and herds. But those people who inhabit places near forests and woods, avail themselves of another method to render the soil productive. A month or two before the rains commence, the farmer sets fire to the underwood, and by this conflagration clears as much land as he intends to cultivate. The soil, immediately after this treatment, if carefully ploughed, acquires considerable fertility, but is liable soon to become barren, unless annually assisted by proper manure. This system of burning down the woods for the sake of obtaining arable land, though not generally permitted in states differently regulated from this, is allowable in a country, the population of which bears so small a proportion to the fertility of the soil, and in which the most beautiful tracts are suffered to remain unproductive for want of hands to cultivate them. In this manner the nomadic Arab proceeds in his conflagrations, till the whole neighborhood around him is exhausted; he then packs up his tents and travels in search of another fertile place where to fix his abode, till hunger again obliges him to continue his migration. Thus it is computed, that at one and the same time no more than a third part of the whole country is in a state of cultivation.

1074. *The live stock of Morocco* consists of numerous flocks and herds. Oxen of a small breed are plentiful, and also camels; the latter animal being used both in agriculture, for travelling, and its flesh as food. The horses are formed for fleetness and activity, and taught to endure fatigue, heat, cold, hunger, and thirst. Mules are much used, and the breed is encouraged. Poultry is abundant in Morocco; pigeons are excellent; partridges are plentiful; woodcocks are scarce; but snipes are numerous in the season; the ostrich is hunted both for sport and for profit, as its feathers are a considerable article of traffic; hares are good; but rabbits are confined to the northern part of the empire, from Saracha to Tetuan. Fallow deer, the roebuck, the antelope, foxes, and other animals of Europe, are not very abundant in Morocco; lions and tigers are not uncommon in some parts of the empire: of all the species of ferocious animals found in this empire, the wild boar is the most common: the sow has several litters in the year, and her young, which are numerous, serve as food for the lion.

1075. *The nomadic agriculturists* form themselves into incampments, called douhars, (fig. 175.) and composed of numerous tents, which form a circle or crescent, and their



flocks and herds returning from pasture occupy the centre. Each douhar has a chief, who is invested with authority for superintending and governing a number of these encampments; and many of the lesser subdivisions are again reunited under the government of a "bashaw;" some of whom have 1000 douhars under their command. Their

tents, of a conical form, and about eight or ten feet high in the centre, and from twenty to twenty five in length, are made of twine, composed of goat's hair, camel's wool, and the leaves of the wild palm, so that they keep out water; but being black, their appearance at a distance is not agreeable. In camp the Moors live in the utmost simplicity, and present a faithful picture of the earth's inhabitants in the first ages. In the milk and wool of their flocks, they find every thing necessary for their food and clothing. It is their custom to have several wives, who are employed in all domestic affairs. Beneath their ill-secured tents they milk their cows and make butter; they sort and sift their wheat and barley, gather vegetables, grind flour with a mill composed of two round stones, eighteen inches in diameter; in the upper one of which is fixed a handle by which it is made to turn upon an axle. They daily make bread, which they bake between two earthen plates, and very often on the ground heated by fire.

1076. *No alteration in the agriculture of Morocco* seems to have taken place for several centuries, owing to the insecurity of its government; every thing being despotic; and property in land, as well as the person and life, being subject to the caprice of the sovereign, and the laws of the moment.

SUBJECT. 4. *Present State of Agriculture on the Western Coast of Africa.*

1077. *Of the innumerable tribes which occupy the west coast of Africa*, the principal are the Jalefs and Foulahs, and of the former little is known. The remaining part of the country consists of the territories of Benin, Loango, and Congo.

1078. *The soil of the Foulah country* is fertile. The inhabitants are said to be diligent as farmers and graziers, and to raise millet, rice, tobacco, cotton, pease, carob beans (*Ceratonia siliqua*, fig. 176.), roots, and fruits in abundance. Their live stock, however, constitutes their chief wealth, and accordingly they roam, pursuing a kind of wandering life, from field to field, and from country to country, with large droves of cows, sheep, goats, and horses; removing, as the wet and dry seasons require, from the low to the high lands, and continue no longer in one place than the pasture for their cattle will allow. The inconvenience and labor of this roving life are augmented by the defence they are obliged to provide against the depredations of the fierce animals with which the country abounds; as they are molested by lions, tigers, and elephants, from the land, and crocodiles from the rivers. At night they collect their herds and flocks within a circle of huts and tents in which they live, and where they light fires in order to deter these animals from approaching them. During the day they often place their children on elevated platforms of reeds (fig. 177.) for security from wild beasts, while they are hunting or pursuing other labors. The elephants are so numerous, that they appear in droves of 200 together, plucking up the small trees, and destroying whole fields of corn; so that they have recourse to hunting, not merely as a pastime, but as the means of self-preservation.

1079. *The English settlement of Sierra-leone* is situated to the west of the country of the Foulahs, on the river Senegal. It was formed in 1787, for the benevolent purpose of promoting African civilisation. A tract of land was purchased from the prince of the country, and a plantation established, in which is cultivated rice, cotton, sugar, pepper, tobacco, and other products; and gum arabic (*Mimosa nilotica*, fig. 178.), and

176



177



178



other valuable articles are procured from the native woods. In these woods the pine apple grows wild in the greatest abundance and luxuriance. The fruit is large and highly flavored, and, when in season, may be purchased by strangers at less than a halfpenny each. A meal in common use by the natives is made from the pounded roots of the manioca (*Jatropha manihot*). This meal, after being first ground from the root, is made into a pulp and pressed to get rid of a poisonous juice. It is then re-dried and constitutes a wholesome farina, which forms almost the entire food of the slaves.

1080. *Benin* is an extensive country; very productive of fruits, trees, and plants; including the orange, cocoa, cotton, &c. and abounding in animals, among which is enumerated civet cats, and a sort of hairy sheep. Agriculture, however, is little attended to, the chief object being the commerce of slaves.

1081. *The inhabitants of Loango*, instead of cultivating the land, content themselves with bread and fish, and such fruits, greens, and pulse, as the soil naturally produces. Coconuts, oranges, and lemons, are not much cultivated; but sugar-canes, cassia, and tobacco, as well as the palm, banana, cotton, and pimento-trees, grow here plentifully. They have also a great variety of roots, herbs, fruits, grain, and other vegetables, of which they make bread, and which they use for food. They have few quadrupeds for domestic use, except goats and hogs, but poultry and various sorts of game are abundant: among the wild beasts they have the zebra, and a great number of elephants, whose teeth they exchange with the Europeans for iron.

1082. *Congo* is an extensive and very fertile country; but the inhabitants are indolent, and neglect its culture. The operations of digging, sowing, reaping, cutting wood, grinding corn, and fetching water, they leave to their wives and slaves. Under their management, several sorts of grain and pulse is cultivated, especially maize, of which they have two crops in a year; but such is the heat of the climate, that wheat will not produce plump seeds; it shoots rapidly up into the straw and ear; the former high enough to hide a man on horseback, and the latter unfilled. Grass grows to a great height, and affords sheltering places for a number of wild animals and noisome reptiles and insects. The Portuguese have introduced a variety of palm and other fruit trees, which are better adapted for producing human food in such a climate.

1083. *The babab (Adansonia digitata)* is a native of Congo. This tree, discovered by the celebrated French botanist, Adanson, is considered the largest in the world: several, measured by this gentleman, were from sixty-five to seventy-eight feet in circumference, but not extraordinarily high. The trunks were from twelve to fifteen feet high, before they divided into many horizontal branches, which touched the ground at their extremities; these were from forty-five to fifty-five feet long, and were so large, that each branch was equal to a monstrous tree; and where the water of a neighboring river had washed away the earth so as to leave the roots of one of these trees bare and open to the sight, they had measured one hundred and ten feet long, without including those parts of the roots which remained covered.

It yields a fruit which resembles a gourd, and which serves for vessels of various uses; the bark of which furnishes them with a coarse thread, which they form into ropes and into a cloth, with which the natives cover their middle from the girdle to the knees; and the small leaves of which supply them with food in a time of scarcity, while the large ones are used for covering their houses, or by burning for the manufacture of good soap. At Sierra-leone, this tree does not grow larger than an orchard apple tree.

1084. *Of the bark of the infanda tree*, and also of the mulemba, resembling in many respects our laurel, they form a kind of stuff or cloth, which is fine, and used for cloaks and girdles by persons of the highest rank. The oil of their palm-trees is used instead of butter; with the moss that grows about the trunk, the rich commonly stuff their pillows; and the *Giagas* apply it to their wounds with good effect: with the leaves the Moors cover their houses, and they draw from these trees, by incision, a pleasant liquor like wine, which, however, turns sour in five or six days.

1085. *Among other fruits and roots*, they have the vine, which was brought thither from Candia, and yields grapes twice a year.

1086. *The live stock* common to other agricultural countries, are here much neglected; but the Portuguese settlers have directed their attention to cows, sheep, and goats, chiefly on account of their milk. Like most parts of Africa, this country swarms with wild animals. Among these, the zebra, buffalo, and wild ass, are hunted, and made useful as food or in commerce. The dante, a kind of ox, whose skins are sent into Germany to be tanned and made into targets, called "dantes," abounds, and also the cameleon, a great variety of monkeys, (fig. 179.), and all the sorts of domestic poultry and game.



179

#### SUBJECT. 5. *Present State of Agriculture at the Cape of Good Hope.*

1087. *The Dutch colonized the Cape of Good Hope* in 1660, and the English obtained possession of it in 1795.

1088. *The climate of this cape* is not unfriendly to vegetation; but it is so situated, within the influence of periodical winds, that the rains are very unequal, descending in torrents during the cold season, though hardly a shower falls to refresh the earth in the hot summer months, when the dry south-east winds prevail. These winds blast the foliage, blossom, and fruit, of all those trees that are not well sheltered; nor is the human constitution secure against their injurious influence. As a protection from these winds, the colonists who inhabit the nearest side of the first chain of mountains, beyond which their effect does not very sensibly extend; divide that portion of their ground which is appropriated to fruit groves, vineyards, and gardens, by oak screens; but they leave their corn lands altogether open. The temperature of the climate at the Cape is remarkably affected by local circumstances. In summer the thermometer is generally between  $70^{\circ}$  and  $80^{\circ}$ , and sometimes between  $80^{\circ}$  and  $90^{\circ}$ , but scarcely ever exceeds  $95^{\circ}$ .

1089. *The surface of the country* consists of some mountains and extensive barren-like plains. The upper regions of all the chains of mountains are naked masses of sandstone; the vallies beneath them are clothed with grass, with thickets, and in some cases with impenetrable forests. The inferior hills or knolls, whose surfaces are generally composed of loose fragments of sandstone, as well as the wide sandy plains that connect them, are thinly strewed over with heaths and other shrubby plants, exhibiting to the eye an uniform and dreary appearance. In the lowest part of these plains, where the

waters subside, and, filtering through the sand, break out in springs upon the surface, vegetation is somewhat more luxuriant. In such situations the farm-houses are generally placed; and the patches of cultivated ground contiguous to them, like the "oases" in the sandy deserts, may be considered as so many verdant islands in the midst of a boundless waste.

1090. *Soils*, in this tract of country, are generally either a stiff clay, impenetrable by the plough till they are soaked by much rain; or light and sandy, tinged with red, and abounding with small round quartzose pebbles. A black vegetable mould seldom appears, except in patches of garden-ground, vineyards, and orchards, that surround the habitations, where, by long culture, manure, and the fertilizing influence of springs or rills of water, the soil is so far mellowed as to admit the spade at all seasons of the year. The extensive plains, known in the colony by the Hottentot name of "Karoo," which are interspersed between the great chains of mountains, exhibit a more dismal appearance than the lower plains, which are chequered with patches of cultivated ground; and their hard surfaces of clay, glistening with small crystals of quartz, and condemned to perpetual drought and aridity, are ill adapted to vegetation. The hills that break these barren plains, are chiefly composed of fragments of blue slate, or masses of felspar, and argillaceous limestone. However, in those Karoo plains that are tinged with iron, and that are capable of being watered, the soil is extremely productive. In such situations, more especially in the vicinity of the Cape, they have the best grapes, and the best fruit of every sort. The great scarcity of water in summer is much more unfavorable to an extended cultivation than either the soil or the climate.

1091. *Landed property* was held by the original Dutch from the government of the Cape on four different tenures. The first tenure was that of a yearly lease, renewable for ever on condition of payment of a certain rent, not in general exceeding eight-tenths of a farthing per acre: the second tenure a sort of perpetual holding, subject to a small rent: the third a holding on fifteen years leases at a quit-rent, renewable: and the last was that of "real estate" or freehold, the settler having purchased his farm at once for a certain sum. The second tenure is the most common in the colony. The lands were originally measured out and allotted in the following manner: a stake was stuck as near the centre of the future estate as could be guessed, and a man, starting from thence, walked for half an hour in a straight line, to each of the four points of the compass; giving thus the radii of a circle that comprised a space of about 6000 acres.

1092. *Of these extensive farms*, the greater part is, of course, mere sheep and cattle walks. They break up for tillage, patches here and there, where the plough can be directed with the least difficulty, or the soil is most inviting for the purpose. A slight scattering of manure is sometimes used, but more frequently none at all; and it is astonishing to see the crops this soil, and even the lightest sands, will produce, with so little artificial stimulus. Seventeen successive crops of wheat without any manure have been taken. When the land is somewhat exhausted by a succession of crops, they break up fresh ground, and the old is suffered to lie fallow, as they term it, for many years; that is, it is permitted to throw up plentiful crops of huge bushes and heath till its turn comes round again, which may be in about seven years, when there is the trouble of breaking it up anew. The sheep and cattle are permitted to stray at pleasure, or are, perhaps, intrusted to the care of a hottentot.

1093. *The agricultural products* of the Cape farmers are chiefly wheat and other grains, pulse, wine, and brandy, wool, hides, and skins, dried fruits, aloes, and tobacco. The returns of grain and pulse are from ten to seventy, according to the nature of the soil and the supply of water. Barley, *i. e.* bear or bigg, is very productive, and is used only for feeding horses. Rye and oats run much to straw, and are chiefly used as green fodder. Indian corn thrives well, and is very productive; and various kinds of millet, kidneybeans, and other pulse are extensively cultivated. The wheat is generally heavier, and yields a finer flour than that of England. It is all spring-wheat, being sown from the month of April to June. The returns are very various in the different soils: some farmers declare that they have reaped sixty and eighty for one; the average may be from twenty to thirty; but it is impossible to come to a true estimate upon this point, as no farmers can tell you the exact quantity sown upon a given quantity of acres.

1094. *The vine*, however, is the most profitable, and what may be considered the staple article of culture. Better grapes are not produced in any part of the world; but the art of making wine and brandy from them admits of much improvement. Ten or twelve different kinds of wine are at present manufactured, having a distinct flavor and quality, according to the farms on which they are produced.

1095. *The celebrated Constantia wine* is made on two farms of that name, close under the mountains between Table bay and False bay. The white wine of that name is made on the farm called Little Constantia, and the other produces the red. The grape is the muscadel, and the rich quality of the wine is owing partly to the situation and soil of the vineyards, and partly to the care taken in manufacturing the wine. No stalks and no fruit but such as is fully ripe, are suffered to go under the press; precautions rarely taken by the other farmers of the Cape. The muscadel grape grows at every farm, and at some farms in Drakenstein, the wine pressed from it is equally good, if not superior, to the Constantia, though sold, on account of the name of the latter, at one sixth-part of the price. When they find that the wine is to be sent abroad, they adulterate it with some other wine: for, according to their own returns, the

quantity exported and consumed in Cape Town, as in the case of Madeira wine, greatly exceeds the quantity manufactured.

1096. *The almond* is a very productive tree at the Cape; the tree thrives in the driest and worst soil, and the fruit, though small, is of excellent quality. Dried peaches, apricots, pears, and apples, are not only plentiful, but good of their kind; dried grapes, or raisins, are not so well managed. Potash is procured from a species of salsola which grows on the deserts; and with this and the fat of sheeps' tails, the farmers make their soap. The berries of the candleberry myrtle (*Myrica cecrifera*) supply a vegetable wax sold at Cape Town in large green cakes, from which odoriferous candles are made.

1097. *The aloe soccotrina, and perfoliata*, cover large tracts of ground, and these afford the inspissated juice or resin of the apothecaries. The leaves of the plant are cut off one by one, and as they are cut, thrown into tubs. In a day or two after they are thrown in, the juice will have run out of itself, when the leaves are taken out and used as manure. The juice is then either clarified in the sun or by boiling, and when dry, cut into cakes and packed up for sale.

1098. *The tobacco* grown at the Cape is said to be as good as that of Virginia. Enough is grown for home consumption, which is considerable; but none for exportation.

1099. *The live stock* of the Cape farmers is chiefly oxen, horses, sheep, swine, and poultry. There are only some districts adapted to grazing; and the farmers who follow this department are in a much less civilized state than the others. The flocks and herds wander over immense tracts, for the use of which a rent or tax according to the number of beasts is paid. At night they are brought home to folds or kraals, which are close to the huts of the farmers, and are represented as places of intolerable filth and stench.

1100. *The native cattle of the Cape* are a hardy, long-legged, bony animal, more in the coach-horse line than fitted for the shambles. They are bad milkers, probably from the bad quality and scanty supplies of forage.

1101. *The sheep* are wretched beasts, more resembling goats, with wool that might be taken for frisky hair, and is in fact only used for stuffing chairs, or such like purposes; the other parts of the body seem drained to supply the accumulation of fat upon the tail, which weighs from six to twelve pounds.

1102. *The Merinos*, of which there are a few flocks, do very well: they are much degenerated for want of changing, and a proper selection of rams.

1103. *The Ryeland, or Southdown sheep*, would be a great acquisition here; for the Cape mutton forms a detestable food.

1104. *The Cape horse*, which is not indigenous, but was introduced originally from Java, is a small, active, spirited animal; a mixture of the Spanish and Arabian, capable of undergoing great fatigue; and, as a saddle-horse, excellently adapted to the country. As a draught-horse for the farmer, he is too small; and the introduction of a few of the Suffolk-punch breed, would be a real benefit to the colony, as well as a source of profit to the importer.

1105. *Pigs* are scarce in the colony amongst the farmers. It is difficult to say why, excepting that there is more trouble in feeding them; and they cannot be turned to graze like sheep. Poultry is, for the same reason, neglected. Indeed, bad mutton may be said to be the only food of the colonists.

1106. *The agricultural implements and operations* of the Cape farmers are said to be performed in the rudest manner, and their crops are thought to depend principally on the goodness of the soil and climate. The plough of the Dutch farmers is a couple of heavy boards nailed together, and armed with a clumsy share, which it requires a dozen oxen to work. Their harrow, if they use any at all, is a few brambles. Their waggons (which will carry about thirty Winchester bushels, or a ton weight, and are generally drawn by sixteen and sometimes twenty oxen) are well constructed to go tilting up and down the precipitous passes of the kloofs with safety; but they have no variety for the different roads. Burchell has given a portrait of one of these imposing machines (*fig. 180.*). Their method of beating out the corn is well known; the



sheaves are spread on a circular floor, surrounded by a low wall, with which every farm is supplied. The farmer's whole stock of brood mares and colts are then turned in, and a black man, standing in the centre, with a long whip to enforce his authority, the whole herd are compelled to frisk and canter round till the corn is trampled out of the ear. This is termed "tramping out." The winnowing is performed by tossing the trampled grain and dung in the air with shovels, or by exposing it to the wind in a sieve.

1107. *The agriculture of the Cape* appears capable of much improvement, were the farmers less indolent, and more ambitious of enjoying the comforts and luxuries of existence. Barrow is of opinion there might be produced an abundance of corn, cattle, and wine, for exportation; but that to effect this, "it will be necessary to procure a new race of inhabitants, or to change the nature of the old ones." At the suggestion of this writer, an attempt was recently made by government to settle a number of British families at the Cape, as cultivators; but after they had gone out and remained there



above a year, they either died or returned completely ruined and disappointed. Neither the climate or mode of culture, indeed, are at all calculated for Britons: for French, German, or Italian peasantry, they may do much better.

1108. *In the interior of the country* are many tribes of whom little or nothing is known; but some of which are every now and then brought into notice by modern travellers. Some have been visited, for the first time, by the missionary Campbell; and the account he gives of their agriculture, manufactures, and customs is often very



curious. It is astonishing how ingenious he found some tribes in cutlery and pottery; and the neatness and regularity of the houses of others is equally remarkable. In one place the houses were even tasteful; they were conical, and enclosed by large circular fences, (fig. 181.);

and he found them threshing out the corn on raised circular threshing-floors (a), with flails, much in the same manner as we do.

1109. *The unimproved Hottentots* form their huts (fig. 182.) of mats bound on a skeleton of poles or strong hoops (fig. 183.) Their form is hemispherical; they are entered by a low door, which has a mat shutter, and they are surrounded by a reed- or mat fence to exclude wild animals and retain fuel and cattle. Attempts to introduce European forms of cottages have been made by the missionaries, which, with a knowledge of the more useful arts, will no doubt in time humanize

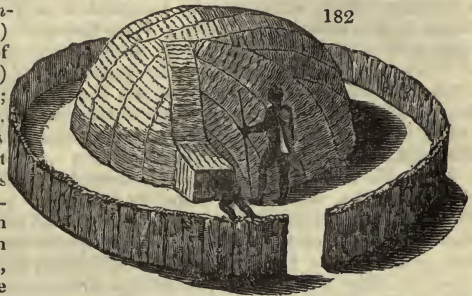

and refine them. The missionary Kùise conducted Burchell along the valley of Genadendal, to exhibit the progress which the Hottentots under his instruction had made in horticulture and domestic order. The valley is a continued maze of gardens and fruit trees. "The huts (fig. 184.),



like those of Hottentot construction, are a rude imitation of the quadrangular buildings of the colonist. They are generally

from ten to fifteen feet long, and from eight to ten wide, having an earthen floor and walls white-washed on their inside, composed of rough unhewn poles, filled up between with reeds and rushes plastered with mud, and the whole covered with a roof of thatch. The eaves being in general not higher



from the ground than four or six feet, the doors could not be entered without stooping. A small unglazed window admitted light, but there was neither chimney nor any other opening in the roof by which the smoke might escape." (Burchell's Travels, i. 112.)

1110. *The cattle of all the Hottentot and other tribes* are kept in circular folds during night; and it is remarkable that these folds are the only burial places known to be in use among that people. "Corn is preserved in what may be termed large jars, of various dimensions, but most commonly between four and five feet high and three wide. The shape of these corn jars is nearly that of an eggshell, having its upper end cut off: sometimes their mouth is contracted in a manner which gives them a great resemblance to an European oil jar. They are formed with stakes and branches fixed into the ground and interwoven with twigs; this frame-work being afterwards plastered within and without with loam and cow-dung. Frequently the bottoms of these jars are raised about six inches or a foot above the ground; and the lower part of the stakes being then uncovered gives them

the appearance of standing on short legs. Their contents are usually protected by a covering of skin or straw." This mode of keeping their corn and beans, Burchell observes, shows a degree of ingenuity equal to that which is displayed in the construction of their houses, and is to be admired for its simplicity and perfect adequateness to the purpose. In the dwellings of the richer inhabitants, the back part of the houses is completely filled with jars of this kind." (*Travels*, ii. 520.)

1111. *The natives of the south of Africa* live much on bulbous roots, of which their country is naturally more productive than any other. Burchell has enumerated a considerable number which he saw them use. One of the most remarkable grows on the mountains of Grafreynet, and is called Hottentot's bread (*Elephantopus*, Willd., *Testudeniaria*, Salisb., fig. 185.) Its bulb stands entirely above ground, and grows to an enormous size, frequently three feet in height and diameter. It is closely studded with angular ligneous protuberances, which give it some resemblance to the shell of a tortoise. The inside is a fleshy substance, which may be compared to a turnip, both in substance and color. From the top of this bulb arise several annual stems, the branches of which have a disposition to twine round any shrub within reach. The taste of this bulb is thought to resemble that of the yam of the East Indies, the plant being closely allied to the genus *Dioscorea*. (*Burchell's Travels*, ii. 147.)



1112. *The Bachapins* are a people of the interior of South Africa, which were visited by Burchell.

Their agriculture, he says, is "extremely simple and artless. It is performed entirely by women. To prepare the ground for sowing they pick it up to the depth of about four inches, with a kind of hoe or mattock, which differs in nothing from a carpenter's adze but in being two or three times larger. The corn they sow is the Caffre corn or Guinea corn, a variety of millet (*Holcus Sorghum Caffrorum*). They cultivate also a kind of kidneybean, and eat the ripe seeds, and also water-melons, pumpkins, and the calabash gourd for the use of its shell as a domestic vessel for drinking and various uses. They are inordinate smokers of tobacco, but they do not cultivate the plant. Burchell gave them some potatoes and peach stones to cultivate, with which they were exceedingly pleased and thankful." (*Travels*, ii. 518.)



1113. *The Bushman spade* (fig. 186.) is a pointed stick about three feet long, to which there is affixed about the middle a stone to increase its power in digging up bulbous roots. This stone is about five inches in diameter, and is cut or ground very regularly to a round form, and perforated with a hole large enough to receive the stick and a wedge by which it is fixed to its place. (*Burchell's Travels*, ii. 30.)

#### SUBJECT. 6. *Present State of Agriculture on the Eastern Coast of Africa, and the African Islands.*

1114. *Of the various countries on the east coast of Africa* the chief is Mocaranga, whose agriculture may be considered as a specimen of that of the savage tribes of the other states. The climate is temperate, though the mountains called Supata, or the spine of the world, forming a great chain from north to south, are perpetually covered with snow; the air clear and salubrious, and the soil fertile and well watered, so that its pastures feed a great number of cattle, more valued by the inhabitants than their gold. The inland parts of the country, however, are sandy, dry, and barren. The products of the country on the coast, are rice, millet, and maize, but no wheat; sugar canes and cotton are found both wild and cultivated. They are without the ox and horse, but elephants, ostriches, and a great variety of wild animals abound in the forests. According to the doubtful accounts of this country, the king on days of ceremony wears a little spade hanging by his side as an emblem of cultivation.

1115. *The island of Madagascar* is celebrated for its fertility, and the variety of its productions. Its climate is mild and agreeable; and the surface of the country is divided into the east and western provinces by a range of mountains. The summits of these mountains are crowned with lofty trees of long duration, and the low grounds are watered by torrents, rivers, and rivulets, which flow from them. The agricultural products are rice, cotton, indigo, sugar, pulse, the yam, banana, cocoa, pepper, ginger, turnerie, and a variety of other fruits and spices. There are a great number of raw fruits and esculent plants, and many curious woods. Oxen and flocks of sheep abound; but there are no horses, elephants, lions, or tigers. The culture is very imperfect, the soil and the excellence of the seasons supplying the place of labor and skill.

1116. *The Mauritius*, or Isle of France, is a productive island, chiefly indebted to the industry of the French, who have introduced there most of the grains, roots, and fruits of other parts of the world, all of which seem to thrive. The climate is excellent, and similar to that of the Bourbon and Canary islands. The surface is mountainous towards the sea coast, but within land there are many spots both level and fertile. The soil is, generally speaking, red and stony. The agricultural products are numerous. A crop of maize, succeeded by one of wheat, is procured in one season from the same field. The rice of Cochín-China is extensively cultivated; the manioc, or cassava (*Jatropha manihot*) of Brazil; sugar, which is the chief product of export; cinnamon, clove, and nutmeg trees, &c. Oranges, citrons, and guavas (fig. 187.) abound; and pine apples are said to grow spontaneously. Many valuable kinds of woods are found in the forests; and on the banks of the rivers are fed the flocks and herds of the country.

1117. *The Isle of Bourbon* differs little in its natural and agricultural circumstances from that of the Mauritius.

1118. *St. Helena* is a rugged, but beautiful island, occupied by a few farmers, chiefly English. Their chief productions are cattle, hogs, and poultry; and when the India ships arrive every house becomes a tavern.

1119. *The Cape Verd Islands* are, in general, hot and unhealthy as to climate, and stony and barren as to soil. Some, however, produce rice, maize, bananas, oranges, cotton, and sugar-canes, with abundance of poultry.

1120. *The Canary Islands* having been subject to Spain for many centuries, the agriculture of the parent country prevails throughout. The climate is temperate, and the soil generally rich. The stock of the farm belongs to the proprietor of the soil, who lends it to the cultivator, on condition of getting half of the produce. The products are, wheat, barley, rice, oats, flax, anise seeds, coriander, the mulberry, grape, cotton, sugar-cane, dragon's blood-tree (*Dracæna*), and a variety of other esculent plants and fruits. The celebrated Canary wine is made chiefly in the islands of Teneriffe and Canary. Potatoes have been introduced within the last fifty years, and now constitute the chief food of the inhabitants. The archil (*Lichen rocella*, Linn. fig. 188 a.), a moss used in dyeing, grows wild on all the rocks; and kali (*Salsola kali*, fig. 188 b.), from which soda is extracted, is found wild on the sea-shore. The roots of the male fern (*Pteris aquilina*) are, in times of scarcity, ground into flour, and used as food. The live-stock of the Canaries consists of cattle, sheep, horses, and asses; and the well-known Canary-bird, with a great variety of others abound in the woods.

1121. *The island of Madeira* is chiefly celebrated for its wine. It is the boast of the islanders, that their country produces the best wheat, the purest sugar, and the finest wines in the world, besides being blest with the clearest water, the most salubrious air, and a freedom from all noxious reptiles. The first view of the island is particularly magnificent; the country rising in lofty hills from every part of the coast so steep as to bring very distant objects into a foreground. The sides of these hills are clothed with vines as high as the temperature will admit; above this they are clothed with woods or verdure to their summits, as high as the sight can distinguish; excepting those columnar peaks, the soil of which has been washed away by the violent rains to which those latitudes, and especially such elevated parts, are liable. Deep ravines or valleys descend from the hills to the sea, and in the hollow of most of them flows a small river, which in general is rapid and shallow. The soil is clay on the surface, and large masses of it as hard as brick, are found underneath. The island, it is said, when discovered by the Portuguese, was covered with wood; and the first step taken by the new settlers was to set fire to the wood. This conflagration is said to have lasted seven years, and to have been the chief cause of the fertility of the soil; but whatever may have been the effect at first, this fertility could not have lasted for three centuries.

1122. *The lands of Madeira* are cultivated on the metayer system: in entailed estates leases cannot be granted for a longer period than nine years; but in no case can the tenant be dismissed till he is paid the full value of his improvements.



187

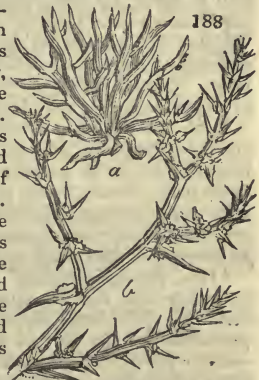

188

1123. *The vine* is cultivated chiefly in the French, but partly in the Italian manner. In the low grounds it is suffered to grow to a considerable height, and tied to trees, poles, or trellises; on the sides of the hills the terrace-culture is adopted, and there the plants are kept lower, and tied to single stakes or low trellises. The variety of grape cultivated is what in France is called the Rhenish; a sort of small black cluster; but its character is greatly altered since its transplantation to Madeira. The grape from which the Malmsey Madeira wine is made is the Ciotat of the French, or parsley-leaved muscadine with a white berry. The quantity of genuine malmsey produced annually is very small; and of that a good deal is supposed to be manufactured with refined sugar. The quality of the wine here as every where else depends more on the aspect and soil than on the kind of grape. The best is grown on the south side of the island, on the lower declivities which point towards the south-east; the west being always cooled by the sea breeze.

1124. *Wheat* is grown on lands previously prepared by the culture of common broom. This is cut for fuel, and after a time, grubbed up and burnt on the soil. By these means, a crop of wheat is insured for a succession of years, more or less, according to the soil; after which the same process is again resorted to. For this purpose, the seeds of the broom are collected, and generally bear the same price by measure as wheat.

1125. *The live-stock* are not numerous. Animals of all sorts, as in most mountainous countries, are small. The beef and mutton appears to a Briton lean and tasteless; common poultry are small; but ducks and turkeys equal those of England. Pork is rare, but excellent, when well fed.

1126. *The tropical fruits* are not readily produced here. In the villages are found guavas, bananas, oranges, and shaddocks, (fig. 189.) Pine apples are reared with great difficulty; but neither the granadilla nor the aligator pear, though they grow vigorously, produce fruit.



### SECT. III. *Present State of Agriculture in North America.*

1127. *The climate* of this region, which extends from the vicinity of the equator to the arctic circle, is necessarily extremely various. In general, the heat of summer, and the cold of winter, are more intense than in most parts of the ancient continent. The middle provinces are remarkable for the unsteadiness of the weather. Snow falls plentifully in Virginia, but seldom lies above a day or two. Carolina and Florida are subject to insufferable heat, furious whirlwinds, hurricanes, tremendous thunder, and fatal lightnings. The climate of the western parts is least known; that of California seems to be in general moderate and pleasant.

1128. *The surface of North America* is nobly diversified with rivers, lakes, mountains, and extensive plains, covered in many places with forests. Its shores are, in general, low, irregular, with many bays and creeks; and the central parts seem to present a vast fertile plain, watered by the Missouri and its auxiliary streams. New Mexico in surface is an alpine country, resembling Norway and Greenland; Labrador, and the countries round the Hudson sea, present irregular masses of mountain, covered with eternal snow. In general, all the natural features of America are on a larger scale than of the old world.

1129. *The agriculture of North America* is chiefly that of the north of Europe; but in the provinces near the equator the culture of the southern parts of Europe prevails; and in the West India islands, that of the warmest climates is followed; there being no production of any part of the world which may not be there brought to perfection. — After this general outline of the agricultural circumstances of North America, we shall select some notices of the agriculture of the United States, the Spanish dominions in North America, British possessions, unconquered countries, and North American islands or West Indies.

#### SUBJECT. 1. *Present State of Agriculture in the United States.*

1130. *The climate of the United States* must necessarily vary in its different parts. In the N.E. the winters are very cold, and the summers hot, changing as you proceed southward. In the S.E., and along the gulf of Mexico, the summers are very hot, and the winters mild and pleasant. Among the mountains it is cold towards the N., and temperate in the S. Beyond the mountains, in the rich valleys of Ohio, Mississippi, and Missouri, the climate is temperate and delightful, till we approach the rocky mountains, when it is subject to extremes, the winters being very cold. The climate must be chilled among mountains constantly covered with snow. West of these mountains, the climate changes, until we reach the shores of the Pacific Ocean, where it resembles that of the western parts of Europe. The prevailing winds are from the west, and as they pass over a wide expanse of water, they cool the air in summer, and in winter deluge the country with frequent rain.

1131. *The seasons* generally correspond with those in Europe, but not with the equality to be expected on a continent, as even during the summer heats single days will occur which require the warmth of a fire. The latitude of Labrador corresponds with that of

Stockholm, and that of Canada with France, but the temperature of those places is widely different.

1132. *The surface of the country in the United States presents every variety.* The north-eastern part on the coast is broken and hilly; and is remarkably indented with numerous bays and inlets. Towards the S., and along the gulf of Mexico, the land is level and sandy, interspersed with many swamps, and numerous islands and inlets. At the outlets of many of the rivers, there is a large portion of alluvial land, which is particularly the case along the Mississippi. Beyond the head of tide-waters, there is a tolerably rich and agreeably uneven country, which extends to the mountains. The mountainous district, on the Atlantic side of the country, is about 150 miles in breadth, and 1200 miles in length. It extends in large ridges, from N.E. to S.W., and is known as the Alleghany mountains. Beyond these the great valley of the Mississippi presents a surface of the finest land in the world. To the westward of this valley are the mountains of Louisiana, and beyond these the bold shores of the Pacific ocean.

1133. *The soil of the United States, though of various descriptions, is generally fertile;* often on the east of the Blue Mountains, in Virginia, a rich, brown, loamy earth; sometimes a yellowish clay, which becomes more and more sandy towards the sea. There are considerable marshes and salt meadows, sandy barrens producing only a few pines, and sometimes entirely destitute of wood. On the west of the Apalachian mountains, the soil is also generally excellent; and in Kentucky some spots are deemed too rich for wheat; but the product may amount to sixty bushels per acre. About six feet below the surface there is commonly a bed of limestone.

1134. *The landed property of the United States is almost universally freehold, having been purchased or conquered by the different states or the general government from the native savages; and these, either lotted out to the conquering army, or reserved and sold afterwards according to the demand.*

1135. *The mode of dividing and selling lands in the United States is thus described by Birkbeck.* "The tract of country, which is to be disposed of, is surveyed, and laid out in sections of a mile square, containing six hundred and forty acres, and these are subdivided into quarters, and, in particular situations, half quarters. The country is also laid out in counties of about twenty miles square, and townships of six miles square, in some instances, and in others eight. The townships are numbered in ranges, from north to south, and the ranges are numbered from west to east; and, lastly, the sections in each township are marked numerically. All these lines are well defined in the woods, by marks on the trees. This done, at a period of which public notice is given, the lands in question are put up to auction, excepting the sixteenth section, which is near the centre, in every township, which is reserved for the support of schools, and the maintenance of the poor. There are also sundry reserves of entire townships, as funds for the support of seminaries on a more extensive scale, and sometimes for other purposes of general interest. No government lands are sold under two dollars per acre; and I believe they are put up at this price in quarter sections, at the auction, and if there be no bidding they pass on. The best lands and most favorable situations are sometimes run up to ten or twelve dollars, and in some late instances much higher. The lots which remain unsold are from that time open to the public, at the price of two dollars per acre; one-fourth to be paid down, and the remaining three-fourths to be paid by instalments in five years; at which time, if the payments are not completed, the lands revert to the state, and the prior advances are forfeited. When a purchaser has made his election of one, or any number of vacant quarters, he repairs to the land-office, pays eighty dollars, or as many times that sum as he purchases quarters, and receives a certificate, which is the basis of the complete title, which will be given him when he pays all; this he may do immediately, and receive eight per cent. interest for prompt payment. The sections thus sold are marked immediately on the general plan, which is always open at the land-office to public inspection, with the letters A. P., *i. e.* advance paid. There is a receiver and a register at each land-office, who are checks on each other, and are remunerated by a per centage on the receipts."

1136. *The price of land, though low when not cleared, rises rapidly in value after a very slight occupation and improvement.* Instances are frequent of a rise of 1000 per cent. in about ten years. Cobbett, who resided in 1817, in Long Island, which may be considered the middle climate of the United States, gives the price of a cultivated farm in that part of the country. "A farm, on this island," he says, "any where not nearer than thirty miles off, and not more distant than sixty miles from New York, with a good farm-house, barn, stables, sheds, and styes; the land fenced into fields with posts and rails, the wood-land being in the proportion of one to ten of the arable land, and there being on the farm a pretty good orchard; such a farm, if the land be in a good state, and of an average quality, is worth *sixty dollars an acre, or thirteen pounds sterling;* of course, a farm of a hundred acres would cost 1300*l.* The rich lands on the necks and bays, where there are meadows, and surprisingly productive orchards, and where there is water carriage, are worth, in some cases, three times this price. But, what I have said will be sufficient to enable the reader to form a pretty correct judgment on the subject. In New Jersey, in Pennsylvania, every where the price differs with the circumstances of water-carriage, quality of land, and distance from market.—When I say a good farm-house, I mean a house a great deal better than the general run of farm-houses in England; more neatly furnished on the inside; more in a parlour sort of style; though round about the house, things do not look so neat and tight as in England."

1137. *The agriculture of the United States may be considered as entirely European, and chiefly British.* Not only is the climate better adapted for the British agriculture, but the great majority of the inhabitants are of British origin. To enter into details of the products and processes of North American agriculture would therefore be superfluous in a work principally devoted to British agriculture. All we shall attempt is, to

notice some of the leading peculiarities of North American agriculture, as resulting from national, political and civil circumstances.

1138. *The natural circumstances of lands not under culture*, chiefly affect the commencement of farming operations. In general, the lands purchased by settlers are underwood, which must be felled or burned, and the roots grubbed up; a laborious operation, which, however, leaves the soil in so rich a state, that it will bear heavy crops of grain, potatoes, and tobacco, with very little culture, and no manure for several years. Sometimes they are under grass, or partially covered with brushwood, in which the operation of clearing is easier. In either case, the occupier has to drain, where necessary; enclose with a ring fence, if he wishes to be compact, to lay out and make the farm road, and to build a house and farmery. The latter he constructs of timber, sometimes plastered with neatness and taste, as in England, (*fig. 190.*) but generally

190

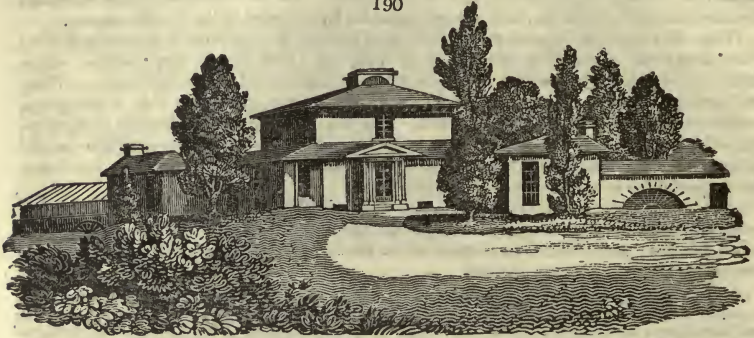

with logs and mud, as in Poland and Russia. (*fig. 191.*) With timber also, he generally forms his fences, though thorn and other live hedges are planted in some of the earlier cultivated districts.

191

1139. *The usual practice of settlers with capital*, may be very well exemplified in the case of Birkbeck. This gentleman having purchased an estate of 1440 acres, in the Illinois, and fixed on that part of it which he intended as his future residence and farm. "The first act was building a cabin, about two hundred yards from the spot where the house was to stand. This cabin is built of round straight logs, about a foot in diameter, lying upon each other, and notched in at the corners, forming a room eighteen feet long, by sixteen; the intervals between the logs 'chuncked,' that is, filled in with slips of wood; and 'mudded,' that is, daubed with a plaster of mud: a spacious chimney, built also of logs, stands like a bastion at one end: the roof is well covered with four hundred clap boards of cleft oak, very much like the pales used in England for fencing parks. A hole is cut through the side, called, very properly, the 'door, (the through)' for which there is a 'shutter,' made also of cleft oak, and hung on wooden hinges. All this has been executed by contract, and well executed, for twenty dollars. I have since added ten dollars to the cost, for the luxury of a floor and ceiling of sawn boards, and it is now a comfortable habitation."



1140. *An example of a settler who began with capital only sufficient to pay the first instalment of eighty dollars of the price of 160 acres of land* is given by the same author, who had the information from the settler himself. Fourteen years ago, he "unloaded his family under a tree," on his present estate; where he has now two hundred acres of excellent land, cleared and in good cultivation, capable of producing from eighty to one hundred bushels of Indian corn per acre. The poor emigrant, having collected the eighty dollars, repaired to the land-office, and entered his quarter section, then worked his way, without another 'cent' in his pocket, to the solitary spot, which was to be his future abode, in a two-horse wagon, containing his family and his little all, consisting of a few blankets, a skillet, his rifle, and his axe. Arrived in the spring: after putting up a little log cabin, he proceeded to clear, with intense labor, a plot of ground for Indian corn, which was to be their next year's support; but for the present, being without means of obtaining a supply of flour, he depended on his gun for subsistence. In pursuit of the game, he was compelled, after his day's work, to wade through the evening dews, up to the waist, in long grass or bushes, and returning, finds nothing to lie on but a bear's skin on the cold ground, exposed to every blast through the sides, and every shower through the open roof of his wretched dwelling, which he does not even attempt to close, till the approach of winter, and often not then. Under these distresses of extreme toil and exposure, debarred from every comfort, many valuable lives have sunk, which have been charged to the climate. The individual whose case is here included, had to carry the little grain he could procure twelve miles to be ground, and remembers once seeing at the mill, a man who had brought his corn sixty miles, and was compelled to wait three days for his turn. Such are the difficulties which these pioneers have to encounter; but they diminish as settlements approach each other, and are only heard of by their successors.

1141. *The political circumstances of the United States* affect the agriculturist both as to the cost of production and the value of produce. It is evident that the want of population must render the price of labor high, and the produce of land low. In this Parkinson, Birkbeck, Cobbett, and all who have written on the agriculture of America, agree. "The simple produce of the soil," Birkbeck observes, "that is to say, grain, is cheap in America; but every other article of necessity and convenience is dear in comparison. Every service performed for one man by another must be purchased at a high rate, much higher than in England." The cheapness of land affords the possession of independence and comfort at so easy a rate, that strong inducements of profit are required to detain men in the condition of servitude. Hence the high price of all

commodities, not simply agricultural; of the labor of mechanics of every description; and hence also the want of local markets for grain, because where three-fourths of the population raise their own grain, (which is the calculation,) the remaining fourth will use but a moderate proportion of the spare produce. The low rate of land and taxes, and this want of home markets, is the reason why the American farmer, notwithstanding the high price of labor, affords his grain so cheap for exportation. Notwithstanding the low rate of produce, the profits of the American farmers are high, on account of the small capital required. With 2000*l.*, Birkbeck calculates that a farm of 640 acres in the Illinois, may be purchased, stocked, and cultivated, so as to return, after deducting all expences, twenty-two per cent., besides the value of the improvements made on the land, that is, its increased value, which, as has already been stated, (1138.) is incredible in a very short time.

1142. *The agricultural products of the United States* include all those of Britain and France. The British grains, herbage, plants, and fruits grown in every district. What appears at first sight very remarkable, is, that in America the native pastures, (excepting on the banks of the rivers,) consist entirely of annuals; and that is the reason why the country is generally bare and black in winter; but perennial grasses when sown in the uplands, are found to thrive in many situations. The greatest quantity of wheat is grown in Pennsylvania and New England. Maize ripens in all the districts, excepting some of the most northerly. Rice is cultivated in Virginia, and on the Ohio; and the vine is indigenous in these and other provinces, though its culture has not yet been much attempted, and some French cultivators are of opinion, that the American soil and climate are unfavorable. This, however, is not likely to be the case, it being a native of the country. The government have established a Swiss colony for its culture, at Vevay, in Indiana, and another in Louisiana, for the culture of the olive. The mulberry, the cotton, and the sugar-cane, are cultivated in Virginia, but not extensively. Sugar is procured plentifully in the woody districts by tapping different species of acer, especially the *saccharinum* in spring; boiling the juice till it thickens, and then granulating it by letting it stand and drain in a tub, the bottom of which is pierced with small holes. The sugar obtained does little more than pay for the labor.

1143. *Of the live stock of the United States* the breed of horses of English extraction is, in general, good, as are the cows and hogs. In many cases there is no limit to the number of these that may be grazed in the unoccupied woods: all that the farmer has to do, is to keep them from bears and wolves, at particular seasons, and keep them tame, as in Russia and Switzerland, by giving them salt. Sheep are totally unfit for the climate, and state of the country, though a number of proprietors have been at great pains to attempt introducing the Merinos. "Mutton," Birkbeck observes, "is almost as abhorrent to an American palate, or fancy, as the flesh of swine to an Israelite; and the state of the manufactures does not give great encouragement to the growth of wool of any kind;—of Merino wool less, perhaps, than any other. Mutton is sold in the markets of Philadelphia at about half the price of beef; and the Kentuckian, who would have given a thousand dollars for a Merino ram, would dine upon dry bread rather than taste his own mutton. A few sheep on every farm, to supply coarse wool for domestic manufacture, seems to be all that ought at present to be attempted in any part of America that I have yet seen. Deep woods are not the proper abodes of sheep. When America shall have cleared away her forests, and opened her uplands to the breezes, they will soon be covered with fine turf, and flocks will be seen ranging over them here, as in other parts of the world.

1144. *Agricultural operations in America* are skilfully performed by the farmers of capital, who have all the best implements of Europe. By the poorest settlers this is not the case, for want of stock; and by the native American farmers, from indolence, which, according to all accounts, is their general defect. An American laborer is most expert at the use of the axe and the scythe; the spade he handles in a very awkward manner, and has no idea of banking, hedging, clipping, or cutting hedges, and many other operations known to every laborer in a highly cultivated and enclosed country like Britain. But the versatility of talent of an American laborer amply compensates for his inexperience in these operations, and is more useful in his circumstances. In handling the saw, the hammer, and even the trowel, the British laborer has no chance with him. Most of them can build a house, mend a plough or waggon, and even the harness, and kill and dress sheep and pigs.

1145. *Field labors in America* require to be performed with much greater expedition than in England. The winter is long and severe, and the transition to spring is sudden; this season in many provinces only lasts a few weeks, when summer commences, and the ground becomes too hard and dry for the operations of tillage. The operations of seed-time must therefore be performed with the greatest rapidity. The climate of New York may be reckoned one of the best in N. America. There the ground is covered with snow, or rendered black by frost in the beginning of December, and continues without

a speck of green till May. Ploughing generally begins in the last week of April; oats are sown in that month; and maize and potatoes about the middle of May. By the end of May the wheat and rye which has stood the winter, the spring-sown corn, the grass, and the fruit trees appear as forward as they are at the same period in England. There is very little rain during June, July, and August. Cherries ripen in the last week of June; by the middle of July the harvest of wheat, rye, oats, and barley, is half over; pears ripen in the beginning of August; maize, (fig. 192.) rye, and wheat, are sown during the whole of October; is cut in the first week of September; peaches and apples are ripe by the end of the month; the general crop of potatoes are dug up in the beginning of November; and also turnips and other roots taken up and housed; a good deal of rain falls in September, October, and November, and severe frosts commence in the first week of December, and as above stated continue till the last week of April. Such is the agricultural year in the country of New York. Live stock requires particular attention during the long winter; and unless a good stock of Swedish turnip, carrot, or other roots has been laid up for them, they will generally be found in a very wretched state in April and May.



1146. *The civil circumstances* of the United States are unfavorable to the domestic enjoyments of a British farmer emigrating thither. Many privations must be suffered at first, and some probably for one or two generations to come. The want of society seems an obvious drawback; but this Birkbeck has shewn is not so great as might be imagined. When an emigrant settles among American farmers, he will generally find them a lazy, ignorant people, priding themselves in their freedom, and making little use of their privileges; but when he settles among other emigrants, he meets at least with people who have seen a good deal of the world and of life; and who display often great energy of character. These cannot be considered as uninteresting, whatever may be their circumstances as to fortune; and when there is something like a parity in this respect and in intellectual circumstances, the social bond will be complete. It must be considered that one powerfully-operating circumstance must exist, whatever be the difference of circumstances or intellect; and that is, an agreement in politics both as to the country left and that adopted. For the rest, the want of society may be to a certain degree supplied by the press; there being a regular post in every part of the United States, and numerous American and European newspapers and periodical works circulated there. Birkbeck mentions that the Edinburgh and Quarterly Review, the Monthly and other magazines, and the London newspapers are as regularly read by him at the prairie in Illinois, as they were at his farm of Wanborough in Suffolk, and that all the difference is, that they arrive at the prairie three months later than they did at his British residence. We have seen sketches of the houses erected by this gentleman, and some others who have settled around him, and we consider them as by no means deficient either in apparent commodiousness or effect. They remind us of some of the best houses of Switzerland and Norway. (fig. 138.)

193



1147. *The want of domestic servants* is a considerable drawback in most parts of the United States; but especially in the new settlements. Families who remove into Western America, Birkbeck observes, should bring with them the power and the inclination to dispense, in a great degree, with servants. To be easy and comfortable there, a man should know how to wait upon himself, and practise it. In other respects, this gentleman and his friends hope to live on their estates at the prairie, "much as they were accustomed to live in England."

1148. *As a country for a British farmer to emigrate to*, we consider the United States superior to every other, in two respects. First on account of its form of government: by which property is secure, — personal liberty greater than any where else, consistently with public safety; and both maintained at less expence than under any government in



the world. Secondly, on account of the stock of people being generally British, and speaking the same language. The only objection we have to America is the climate, the long and severe winter, and the rapid and hot spring and summer. Equally good land, and nearly as cheap, may be had in the south of Russia and in Poland, as in America; but who that knows any thing of the governments of those countries, or even of Germany and France, would voluntarily put themselves in their power while the United States are accessible? Who would live in a country of tyrannic nobles, often very deficient of moral principle; and of a peasantry little better than hogs, and not so well fed and lodged as that animal is in England? Who would live in a country of passports, of spies, and swarming with beggarly gentry, wohlgeborne, hochwohlgeborne, edilgeborne, hochedelgeborne, &c.; and where exists that precious article hochjagt; being a description of game which no man may pursue under the rank of prince? Who would emigrate to Hanover if he could settle in France; and who would go there if he could accomplish the voyage to the United States?

1149. *Van Diemens Land and New Holland*, next to the United States, are perhaps the most desirable places to go to; and they are superior to America in climate; but no man is safe under a delegated and distant administration of government; and, besides, if a man is to leave his country, it seems preferable to emancipate himself at once from all the good and evil of the old world state of society and government, and plunge into a new and superior order of things. No person, however, should determine on so important a step without making himself, as far as practicable, master of all that has been said, written, or done on both sides of the question. For this purpose he may consult what has been published by Parkinson, England, Fearon, Wild, Birkbeck, Cobbett, Mellish, Helme, Dwight, Hodgson, and a variety of others.

SUBJECT. 2. *Present State of Agriculture in Mexico.*

1150. *The climate of this extensive and recently revolutionized country* is singularly diversified, between the tropical seasons and rains, and the temperature of the southern and even middle countries of Europe. The maritime districts of Mexico are hot and unhealthy, so as to occasion much perspiration even in January; the inland mountains, on the other hand, present snow and ice in the dog-days. In other inland provinces, however, the climate is mild and benign, with some snow of short duration in winter; but no artificial warmth is necessary, and animals sleep all the year under the open sky. From April to September there are plentiful rains, generally after noon; hail storms are not unknown; thunder is frequent; and earthquakes and volcanoes occasionally occur. The climate of the capital, in lat. 19° 25', differs much from that of the parts of Asia and Africa under the same parallel; which difference seems to arise chiefly from the superior height of the ground. Humboldt found, that the vale of Mexico is about 6960 feet above the level of the sea, and that even the inland plains are generally as high as Mount Vesuvius, or about 3600 feet. This superior elevation tempers the climate with a greater degree of cold; upon the whole, therefore, it cannot be regarded as unhealthy.

1151. *The surface* of the country is diversified by grand ridges of mountains, numerous volcanoes, some of which are covered with perpetual snow, cataracts worthy of the pencil of Rosa, delicious vales, fertile plains, picturesque lakes and rivers, romantic cities and villages, and an union of the trees and vegetables of Europe and America.

1152. *The soil* is often deep clay, surprisingly fertile and requiring no manure except irrigation. In some places it is boggy or composed of a soft black earth, and there are barren sands and stony soils in the elevated regions.

1153. *Of the agriculture of Mexico* some account is given by the abbe Clavigero and the baron de Humboldt. According to the first author, agriculture was from time immemorial exercised by the Mexicans, and almost all the people of Anahuac. The Toltec nation employed themselves diligently in it, and taught it to the Thechemecan hunters. With respect to the Mexicans, we know that during the whole of their peregrination, from their native country Atzlan, unto the lake where they founded Mexico, they cultivated the earth in all those places where they made any considerable stop, and lived upon the produce of their labor. When they were brought under subjection to the Colluan and Tepanecan nations, and confined to the miserable little islands on the lake, they ceased for some years to cultivate the land, because they had none, until necessity and industry together, taught them to form moveable fields and gardens, which floated on the waters of the lake.

1154. *The method of forming floating fields*, and which they still practise, is extremely simple. They plait and twist willows, and roots of marsh plants, or other materials, together, which are light, but capable of supporting the earth of the field firmly united. Upon this foundation they lay the light bushes which float on the lake, and over all, the mud and dirt which they draw up from the bottom of the same lake. Their regular figure is quadrangular; their length and breadth various; but in general, they are about eight perches long, and not more than three in breadth, and have less than a foot of elevation above the surface of the water. These were the first fields which the Mexicans owned

after the foundation of Mexico; there they first cultivated the maize, great pepper, and other plants, necessary for their support. In progress of time as those fields grew numerous from the industry of those people, there were among them gardens of flowers and odoriferous plants, which were employed in the worship of their gods, and served for the recreation of the nobles. At present they cultivate flowers, and every sort of garden herbs upon them. Every day of the year, at sun-rise, innumerable vessels loaded with various kinds of flowers and herbs, which are cultivated in those fields and gardens, are seen arriving by the canal, at the great market-place of that capital. All plants thrive there surprisingly; the mud of the lake is an extremely fertile soil, and requires no water from the clouds. In the largest islands there is commonly a little tree, and even a little hut to shelter the cultivator, and defend him from rain or the sun. When the owner of an island, or the *chinampa*, as he is usually called, wishes to change his situation, to remove from a disagreeable neighbor, or to come nearer to his own family, he gets into his little vessel, and by his own strength alone, if the garden is small, or with the assistance of others, if it is large, he tows it after him, and conducts it wherever he pleases with the little tree and hut upon it. That part of the lake where those floating fields are, is a place of infinite recreation, where the senses receive the highest possible gratification. These floating fields, Humboldt informs us, still exist: they are of two sorts; the one mobile and blown here and there by the winds, and the others fixed and united to the shore. The former alone merit the appellation of floating, and they are diminishing day by day. He assigns to them the same origin as the abbe Clavigero; but thinks it probable that nature also may have suggested the first idea, and gives instances of small pieces of the surface, netted with roots and covered with plants, being detached from the marshy shores of other American lakes, and floating about in the water. The bean, pea, apple, artichoke, cauliflowers, and a great variety of other culinary plants are cultivated on them.

1155. *A floating island, in a small lake in Haverhill, in New England, is mentioned by Dr. Dwight. It has, he was informed, immemorially floated from one shore to another, whenever it was impelled by a violent wind. Lately it has adhered for a considerable time to a single spot; and may perhaps be so firmly fixed on the shelving bottom, as to move no more hereafter. Several trees and shrubs grow on its surface, and it is covered by a fresh verdure. (Travels, &c. vol. i. p. 371.)*

1156. *Having neither ploughs nor oxen, nor any other animals proper to be employed in the culture of the earth, the Mexicans, when they had shaken off the Tepanecan yoke, supplied the want of them by labor, and other more simple instruments. To hoe and dig the ground they made use of the *coatl*, or *coa*, which is an instrument made of copper, with a wooden handle, but different from a spade or mattock. They made use of an axe to cut trees, which was also made of copper, and was of the same form with those of modern times, except that we put the handle in the eye of the axe, whereas they put the axe into an eye of the handle. They had several other instruments of agriculture; but the negligence of ancient writers on this subject has not left in our power to attempt their description.*

1157. *They irrigated their fields with the water of rivers and small torrents which came from the mountains, raising dams to collect them, and forming canals to conduct them. Lands which were high, or on the declivity of mountains, were not sown every year, but allowed to lie fallow until they were over-run with bushes, which they burned, to repair by their ashes the salt which rains had washed away. They surrounded their fields with stone enclosures, or hedges made of the penguin, which make an excellent fence; and in the month Panquetzaliztli, which began on the third of December, they were repaired if necessary.*

1158. *In sowing of maize, the method they observed, and which they still practise in some places, is this: the sower makes a small hole in the earth with a stick, or drill probably, the point of which is hardened by fire; into this hole he drops one or two grains of maize from a basket which hangs from his shoulder and covers them with a little earth by means of his foot; he then passes forward to a certain distance, which is greater or less according to the quality of the soil, opens another hole, and continues so in a straight line unto the end of the field; from thence he returns, forming another line parallel to the first. The rows of plants by these means are as straight as if a line was made use of, and at as equal distances from each other as if the spaces between were measured. This method of sowing, which is now used by a few of the Indians only, though more slow, is, however, of some advantage, as they can more exactly proportion the quantity of seed to the strength of the soil; besides that there is almost none of the seed lost which is sown: in consequence of this, the crops of the fields which are cultivated in that manner are usually more plentiful. When the maize springs up to a certain height, they cover the foot of the plant round with earth, that it may be better nourished, and more able to withstand sudden gusts of wind.*

1159. *In the labors of the field the men were assisted by the women. It was the business of the men to dig and hoe the ground, to sow, to heap the earth about the plants, and to reap; to the women it belonged to strip off the leaves from the ears, and to clear the grain; to weed and to shell it was the employment of both.*

1160. *They had places like farm-yards, where they stripped off the leaves from the ears, and shelled them, and granaries to preserve the grain. Their granaries were built in a square form, and generally of wood. They made use of the *ojameth* for this purpose, which is a very lofty tree, with but a few slender branches, and a thin smooth bark; the wood of it is extremely pliant, and difficult to break or rot. These granaries were formed by placing the round and equal trunks of the *ojameth* in a square, one upon the other, without any labor except that of a small notch towards their extremities, to adjust and unite them so perfectly as not to suffer any passage to the light. When the structure was raised to a sufficient height, they covered it with another set of cross-beams, and over these the roof was laid to defend the grain from rains. Those granaries had no other door or outlet than two windows, one below which was small, and another somewhat wider above. Some of them were so large as to contain five or six thousand, or sometimes more *fanegas* of maize. There are some of this sort of granaries to be met with in a few places at a distance from the capital, and amongst them some so very ancient, that they appear to have been built before the conquest; and, according to information had from persons of intelligence, they preserve the grain better than those which are constructed by the Europeans.*

1161. *A little tower of wood, branches and mats they commonly erected close to fields which were sown, in which a man defended from the sun and rain, kept watch, and drove away the birds which came in flocks to consume the young grain. Those little towers are still made use of even in the fields of the Spaniards on account of the excessive number of birds.*

1162. *The woods which supplied them with fuel to burn, timber to build, and game for the diversion of the king, were carefully preserved. The woods of king Montezuma were extensive, and the laws of king Nezahualcojotl concerning the cutting of them particular and severe in their penalties. It would be of advantage to that kingdom, says Clavigero, that those laws were still in force, or at least that there was not so much liberty granted in cutting without an obligation to plant a certain number of trees; as many people, preferring their private interest and convenience to the public welfare, destroy the wood in order to enlarge their possessions.*

1163. *The breeding of animals was not neglected by the Mexicans: though there were no sheep, they bred up innumerable species of animals unknown in Europe. Bullock (Travels, 1824) informs us, that they are very curious in rearing and feeding swine; and that an essential requisite in a Mexican swineherd is an agreeable voice; in order that he may sing or charm the animals into peace when they quarrel and fight, and lull them*

to sleep at proper times, to promote their fattening. Wind and sounds of every kind have been long known to have a powerful effect on this genus of animals. Private persons brought up *techichis*, quadrupeds, similar to little dogs; turkeys, quails, geese, ducks, and other kinds of fowl. In the territories of the lords were bred fish, deer, rabbits, and a variety of birds; and at the royal residences, almost all the species of quadrupeds, and winged animals of those countries, and a prodigious number of water animals and reptiles. We may say that in this kind of magnificence Montezuma II. surpassed all the kings of the world, and that there never has been a nation equal in skill to the Mexicans in the care of so many different species of animals, which had so much knowledge of their dispositions, of the food which was most proper for each, and of all the means necessary for their preservation and increase.

1164. *The Mexican cochineal*, so greatly valued in Europe on account of its dyes of scarlet and crimson, demands a great deal more care from the breeder than is necessary for the silkworm. Rain, cold, and strong winds destroy it. Birds, mice, and worms, persecute it furiously, and devour it; hence it is necessary to keep the rows of opuntia, or nopal, where those insects are bred, always clean; to attend constantly to drive away the birds, which are destructive to them; to make nests of hay for them among the opuntia, by the juice of which they are nourished; and when the season of rain approaches, to raise them with a part of the plants, and guard them in houses. Before the females are delivered they cast their skin, to obtain which spoil, the breeders make use of the tail of the rabbit, brushing most gently with it that they may not detach the insects from the plants, or do them any hurt. On every lobe they make three nests, and in every nest they lay about fifteen cochineals. Every year they make three gatherings, reserving, however, each time, a certain number for the future generation; but the last gathering is least valued, the cochineals being smaller then, and mixed with the prickles of the opuntia. They kill the cochineal most commonly with hot water. On the manner of drying it afterwards the quality of the colour which is obtained from it chiefly depends. The best is that which is dried in the sun. Some dry it in the *comalli*, or pan, in which they bake their bread, of maize, and others in the *temaxcalli*, a sort of oven. (*Clavigero*, vol. i. p. 357 to 381.)

1165. *The fruits of Mexico* are very numerous, the banana, (*fig. 194.*) and granadilla, (*fig. 195.*) are very common. The bread-fruit and cocoa are extensively cultivated;



and a number of sorts of anona, or custard apple, (*fig. 196.*), and especially the cherimoy (*A. tripetala*), which is much esteemed. In short, all the fruits of Europe and most of those of both Indies are to be found in the gardens of the nobles and the priests.

SUBJECT. 3. *Present State of Agriculture in the British Possessions of North America.*

1166. *The principal British provinces in America* are Canada, New Brunswick, Nova Scotia, Cape Breton, and the adjacent islands of Newfoundland and the Bermudas.

1167. *Canada* is an extensive country, and the only British province in which agriculture is generally pursued. The climate of this country is extremely irregular; in July and August, the heat is often 96°, while in winter the mercury freezes. The ground is covered with snow from November till May, when it thaws suddenly, and vegetation is instantaneous. The surface of the country is generally mountainous and woody; but there are savannas, and plains of great beauty towards Upper Canada.

1168. *The soil* consists principally of a loose dark-coloured earth, ten or twelve inches deep, lying on a bed of cold clay. This thin mould, however, is very fertile, and yields plentiful



crops, although it is worked every year by the French Canadians, without being ever manured. The manures chiefly used, since the practice of manuring has been introduced, by those who are the best farmers, are marle and gypsum, the former is found in great quantities in many places along the shores of the river St. Lawrence.

1169. *With respect to the products of Canada*, the low country is peculiarly adapted to the growth of small grain. Tobacco also thrives well in it, but the culture is neglected, except in private use; and more than half of what is used is imported. The snuff produced from the Canadian tobacco is held in great estimation. Culinary vegetables arrive at great perfection in Canada, which is also the case with most of the European fruits. The currants, gooseberries, and raspberries are very fine; the latter are indigenous, and are found very abundantly in the woods. A kind of vine is also indigenous; but the grapes produced by it in its uncultivated state are very poor and sour, and not much larger than fine currants. In the forest there is a great variety of trees; such as beech, oak, elm, ash, pine, sycamore, chestnut, and walnut; and the sugar maple-tree is found in almost every part of the country. Of this tree there are two kinds; the one called the swamp maple, being generally found on low lands, and the other, the mountain or curled maple, from its growing upon high dry ground, and from the grain of its wood being beautifully variegated with little stripes and curls. The former yields more sap than the latter, but its sap affords less sugar. A pound of sugar is frequently procured from two or three gallons of the sap of the curled maple, whereas no more than the same quantity can be had from six or seven gallons of that of the swamp tree. The maple sugar is the only sort of raw sugar used in the country parts of Canada, and it is also very generally used in the towns.

1170. *New Brunswick and Nova Scotia* are intensely cold countries, and only partially civilised. The vale of St. John's river is the principal scene of cultivation in New Brunswick. The upland parts of the country are chiefly covered with forests of pines, hemlock, and spruce fir, beech, birch, maple, and some oak. The pines on St. John's river are the largest in British America, and afford a considerable supply of masts for the royal navy. Nova Scotia produces little grain; supplies being sent from England. The soil is thin and barren, excepting on the banks of the river, where it produces grass, hemp, and flax.

1171. In the island of *Cape Breton* the soil is mere moss, and has been found unfit for agriculture. Newfoundland seems to be rather hilly than mountainous, with woods of birch, pine, and fir, numerous ponds and morasses with some dry barrens. The chief produce of these islands, as well as the other British possessions in America, is furs and skins; and the same remark will apply to the Bermudas and other unconquered countries, which need not be further noticed.

#### SUBJECT. 4. *Present State of Agriculture in the West India Islands.*

1172. *The principal West India islands* are Cuba, St. Domingo, Jamaica, and Porto Rico; and next the Windward islands, Trinidad, the Leeward islands of the Spanish, and the Bahamas.

1173. *Cuba* is an extensive and naturally fertile island, but from the indolence of the Spaniards not above a hundredth part of it is cleared and cultivated. Like most islands in the West Indies, it is subject to storms, but the climate is, upon the whole, healthy, and even temperate; for though in this latitude there is no winter, the air is refreshed with rains and cooling breezes. The rainy months are July and August; the rest of the year is hot. A chain of mountains extends the whole length of the island from east to west, and divides it into two parts; but the land near the sea is in general level, and flooded in the rainy season. The soil is equal in fertility to any in America, producing ginger, long pepper, and other spices; aloes, mastich, cassia fistula, manioc, maize, cocoa, &c. Tobacco is one of its principal productions, and it is supposed to have the most delicate flavor of any produced in the new world. The cultivation of sugar has lately been introduced; but the indolence of the inhabitants renders it in every respect much less productive than it otherwise might be. The quantity of coffee is inconsiderable. The chief plantations are in the plains, and are cultivated by about 25,000 slaves. Among the trees are oaks, firs, palms, cotton trees, ebony, and mahogany, (*Svietenia Mahogani*, fig. 197.) In 1763 bees were introduced by some emigrants from Florida, and they multiplied so much in the hollows of old trees, that they soon obtained honey enough for their annual consumption. In 1777 they exported honey to the amount of 715,000 pounds. The



island abounds with mules, horses, sheep, wild boars, hogs, and fine black cattle. The horned cattle have increased so much that the forests are filled with droves of them, which run wild, and are hunted and killed for their hides and tallow. The chief birds are paroquets, turtle doves, and partridges; water-fowl are numerous; and on the coast turtles are abundant; mullets and shads are the principal fish.

1174. *Jamaica* has been in possession of the English since the middle of the seventeenth century. The climate is extremely hot throughout the year, though mitigated by various causes. The surface of the country is very irregular: a ridge of mountains from east to west divides it into two parts. At a small distance from the shore it rises into hills with gentle acclivity, which are separated from each other by spacious vales and romantic inequalities. On the southern side of the island there are precipices and inaccessible cliffs, amidst which are vast plains, covered with extensive cane fields. To the inequalities of surface that distinguish this island it is owing, that, although the soil in many parts of the island is deep and very fertile, yet the productive land is but of small extent, in proportion to the whole. That which is actually cultivated is of a middling quality, and requires labor and manure to make it yield liberally.

1175. *Landed property in Jamaica* is in general freehold without manorial rights, and is chiefly in the enjoyment of individuals, though there is some government and corporation territory. Estates are generally small, few exceeding 1000 acres: formerly they were managed by resident proprietors; but at present, and for some time past, by far the greater number have been managed by agents or attorneys, who are represented by Roughley as a selfish, grasping, unprincipled set of men, "too ignorant to be planters, and too ostentatious, proud, and supine, to contribute to the good of their constituents." (*Planter's Guide*, p. 8.) They often contrive, by getting estates in debt and mortgaging them, ultimately to become the proprietors themselves. Some proprietors are so over-careful as to have what is called a planting attorney, and a mercantile attorney, the latter for the sale of produce, and the purchase of imported stores for the slaves. Besides these there are travelling agents who visit different estates, and make annual or biennial voyages to Europe to the proprietors; an overseer for each estate, who has both free white men and slaves under him; a head driver, a slave; the head cattle and mule man; the head boiler or manufacturer of sugar; head carpenters, coopers, masons, coppersmiths, and watchmen; a hot-house or hospital doctor or doctress midwife; the great gang of able men and women; the second gang of rather weakly habits; and the third, or weeding gang, composed of children; cattle and mule boys, watchmen, invalids, and superannuated, and young children and infants. The qualifications, duties, and treatment of all these classes are discussed at length by Roughley, who gives a picture of culture and management very different from any thing belonging to the management of landed property, or the culture of farm lands in Britain.

1176. *The overseer*, who is generally known by his hat and pipe (*fig. 198.*), should be a man of intelligence, tempered with experience, naturally humane, steadfast in well-devised pursuits, of settled sober habits, not given to keeping indiscriminate company, or suffering his subordinate white people to do so, thereby vitiating their manners; presenting a gentleman-like appearance, keeping a regular, well-supplied comfortable table, without profusion, not only for himself and the white people under him, but for the benefit of such sick and convalescent slaves as require salutary and restoring nourishment. His business hours will be fully occupied by the concerns of the estate, his leisure ones in the innocent enjoyment of some domestic amusement. He must be kind and courteous to the young men under him, but giving or allowing them no opportunity to treat him with disrespect; attentive and hospitable to respectable strangers, cautious and wary how he suffers strollers to tempt his benevolence. He must not capriciously or suddenly discharge his white people (as is very often the case), taking care that no envious or jealous sentiment or idea arises in his mind, if his young men have merit on their side, or are caressed by their superiors. He must keep the slaves strictly to their work, yet not imposing on them unusual hours, or inflicting punishment for every trifling offence; but when punishment for crimes is necessary, to temper it with prudent mercy. He must be attentive to their real wants, not suffering them to tease him with their trifling complaints, or tamper with him by their arts, but promptly satisfy them, by enquiring into their serious grievances. Above all things, he must not encourage the spirit of Obea in them (which is horrible), or dishearten them by cohabiting with their wives, annulling thereby their domestic felicities. He must not suffer their provision-grounds to be neglected, trespassed on, or ruined, or their houses to be out of repair or uncomfortable; for it very often happens, that well-disposed slaves, by such freedoms taken with their wives, their well-established grounds ruined by thieves or cattle, their domestic quiet and comfort intruded upon, or their houses rendered uninhabitable by storm or casualty, become runaways. Their conduct influences others, till at last the strength of the estate vanishes, the evil becomes notorious, and the plantation, of course, becomes neglected. The magistrates are then obliged to take this growing evil into serious consideration. Hunting parties are sent out (perhaps with little success) to bring in the fugitives; martial law is at last proclaimed throughout the diseased district; all sorts of people are harassed; public trials are instituted; some of the runaways are never caught; others who are brought in undergo trial, and are convicted and sentenced to death or transportation for life. (*Roughley*, 40, 43.)

1177. *The head driver* is seen carrying with him the emblems of his rank and dignity, a polished staff or wand, with prongy crooks on it to lean on, and a short-handled flexible whip; his office combining within itself a power, derived principally from the overseer, of directing all conditions of slaves, relative to the precise work he wishes each gang or mechanic to undergo or execute. The great gang is comprised of the most powerful field negroes, and is always under his charge. These are the strength with which principally to carry into effect the main work in the field, and manufacture the sugar and rum. There are so many points to turn to, so many occasions for his skill, vigilance, steadiness, and trust-worthiness, that the selection of such a man, fit for such a place, requires circumspection, and an intimate knowledge of his talents and capacity. A bad or indifferent head driver sets almost every thing at variance; injures the negroes, and the culture of the land. He is like a cruel blast that pervades every thing, and spares nothing; but when he is well-disposed, intelligent, clever, and active, he is the life and soul of an estate. He very often is an elderly or middle-aged negro, who has long been so employed. If it should be so ordered, that a new head driver is requisite to be put in commission, I must beg leave to lay before my readers my opinion of the proper choice of one. I may err, but hope not irretrievably. He should, in my judgment, be an athletic man; sound and hardy in constitution; of well-earned and reputed good character; of an age, and, if possible, an appearance to carry respect; perhaps about thirty-five years old; clean in his person and apparel; if possible a native or creole of the island, long used to field work, and marked for his sobriety, readiness, and putting his work well out of his hands. His civility should be predominant,



his patience apparent, his mode of inflicting punishment mild. He should be respectful to white people; suffering no freedoms from those under him, by conversation or trifling puerile conduct. It is rare, indeed, to find this mass of perfection in a negro; but you obtain a combination of most of these virtues; and, as to petty vices, always inherent in some measure in human nature, they must be looked over, when not too full of evil. The junior drivers likewise, if possible, should be men of this description; but having a good master over them in the head driver, they will be induced to behave tolerably. (*Roughley*, 79. 82.)

1178. *The laborers on a sugar Jamaica estate* consist almost entirely of slaves, creoles, natives, or Africans, with some free blacks and men of color or mixed progeny. The overseers are almost always whites, and sometimes also the head drivers.

1179. *The buildings required for a sugar plantation* are numerous and extensive. In a central situation by a stream or other supply of water, "an extensive set of works, including an overseer's house, hospital or hot-house, mill-house, large mill-yard, mule stable, trash or fuel house, cooper and carpenter's shops, boiling and curing houses, a distilling house, tanks, cisterns, &c. should be built and so arranged as all to be seen from the overseer's house.

1180. *The overseer's house*, it would appear, must be both a comfortable and elegant building. It should be built compact and convenient, not over roomy; and raised sufficiently high from the foundation, with good masonry work, to admit of suitable stores underneath, to keep all the plantation stores and supplies in. It should be placed so, that all the works can be seen from it, and not far from the boiling-house. The rooms should be all on the same floor, and closely boarded with seasoned stuff. Each white man should have a small bed-room to himself, with a glazed sash window on hinges, and a shutter to it. The bed-rooms should be eleven feet by nine each, of which five should be in every overseer's house on a sugar estate, leaving the overseer's room somewhat larger than the book-keeper's. A large well-covered piazza, with comfortable glazed windows, (to rise and fall occasionally,) will answer all the purpose of a dining and breakfast hall, and for walking in. Large centre halls in such houses are of very little use, take up a great deal of room, are very expensive, and make the house large, without any real convenience. A small back piazza, made comfortable by moving blinds with stops, would be proper for the servants. I think every dwelling-house on a plantation should have a small fire-place in it, with a well-raised chimney, for fire occasionally in damp weather to be made in; it will be wholesome and preservative. The fire-place should be in an extreme angle of the dining piazza, and the overseer's cooking-room, washing-room, &c., should be apart from the house, though not far off, conveniently fitted up, and of moderate size. The little appendages of a hog-stye, fowl-house, &c., to raise small stock in, are easily built at a small expense. (*Ib.* 184, 185.)

1181. *A lime kiln* is an essential building for a sugar estate, a considerable quantity of lime being wanted to neutralize the acid of the expressed juice of the cane. A fixed kiln at the works is best, as what lime is wanted can then be burnt at any time; but it often happens that temporary kilns, composed of layers of stones and wood, with a funnel in the centre, are made in the woods, lighted and burnt, and the produce carried home. Such a kiln, twenty feet in diameter, and ten or twelve feet high, will produce lime enough to make sixteen hogsheds of sugar. (*Ib.* 314.)

1182. *The houses of the slaves* are grouped together on some estates, and scattered in different places in others, generally on the outskirts of the estate. They are low cottages of one or two apartments, with open sheds, and pieces of garden ground of from one-eighth to one-quarter of an acre attached to each, and some of them are kept neat, and have a clean, not uncomfortable appearance; they are generally built with stone, and covered with shingles.

1183. *Every building composing the works of a sugar estate* should be composed of the most substantial materials, durable, hard, well-seasoned timber, well put together, and supported by the best mason work. They should be shingled instead of being thatched, and kept free from the hungry, destructive ant, who, by his mighty though diminutive efforts, will level a substantial building to the ground in a short time. Poisoning by arsenic is the most expedient mode of getting rid of them, as the living will feed on the dead, so that the whole nest, (by devouring one another,) are thus killed. (*Ib.* 194.)

1184. *The live stock of a sugar estate* are chiefly oxen, spayed heifers, and mules, as beasts of labor; the overseer generally keeps a riding horse, as does the resident agent or proprietor if there are such; and there are pigs and poultry, with some sheep for consumption. The cattle and mules are kept on the savannahs or open waste pastures, and on Guinea grass (*Panicum*) and Scotch grass (*Panicum hirtellum*, *fig.* 199 a.) on which they are folded, tethered, or soiled. Mares and Spanish or Maltese jackasses are kept for breeding the mules; and the cattle are in general reared on the estate. A jack should be from ten to twelve hands high, and either stabled or put into a close pasture, with high, firm walls and gates to it. He should be regularly corned once a day at least; should have pure water to drink, and not suffered to cover more than one mare daily. The mares should be put to him in season, and attended by an experienced groom. A proper covering pit should be made for the mare to stand in, with a surmounting stage for the jack to stand on. They should be daily taken and led out to exercise, kept well cleaned, and by no means allowed to stay out in bad weather, but comfortably stabled, foddered, and littered. (*Ib.* 141, 142.)

1185. *The agricultural operations of Jamaica* are for the most part performed by the manual labor of indigenous slaves, but natives are also imported from different parts of the coast of Africa. The soil is seldom either ploughed or dug, but generally worked with the hoe pick. The spade the negroes are awkward at using; and they are not less expert at the plough. White ploughmen have been imported by some cultivators; but the prejudices of the overseers, the awkwardness of the oxen and negro drivers, and the effects of the climate in wearing out the spirits of the ploughman, are said to have discouraged its use. Long in 1774, Dr. Stokes, (*Young's Annals of Agr.* xviii. 148.) and others, have tried the plough, and strongly recommend it as doing the work better and lessening the necessity of having so many slaves. Roughley, however, who was "nearly twenty years a sugar planter in Jamaica," (*Jamaica Planter's Guide*, 1823.) is decidedly against it, whether drawn by negroes or cattle; both because it does not do the work so well as the hoe, and because of the difficulty of getting ploughmen and properly trained beasts. It is probable, however, that necessity may ultimately lead to the use of the plough drawn by oxen, and that the operative man in the West India islands will in time assume the same attitude as in Europe.

1186. *The agricultural productions of Jamaica* of the greatest importance are sugar, indigo, coffee, and cotton. The several species of grain cultivated in this island are maize or Guinea corn, yielding from thirty to sixty bushels an acre; and various kinds of calavances, a species of pea; and rice, but in no great quantity. The island abounds also with different kinds of grass, of excellent quality: the artificial grass, called "Scots grass" (*Panicum hirtellum*, *fig.* 199 a.) grows spontaneously in most of the swamps and morasses of the West Indies; and it is so pro-

ductive, that a single acre of it will maintain five horses for a whole year. The "Guinea-grass" (*P. polygonum*, fig. 199 b.) is next in importance to the sugar-cane, as the grazing and breeding farms are chiefly supported by it. Hence arises the plenty of horned cattle, both for the butcher and planter; which is such, that few markets in Europe furnish beef of better quality, and at a cheaper rate than that of Jamaica. Mutton also is cheap and good. The seeds of the Guinea-grass were brought from the coast of Guinea, as food for some birds which were presented to Ellis, chief justice of the islands. The several kinds of kitchen-garden productions, that are known in Europe, thrive in the mountains of this island; and the markets of Kingston and Spanish Town are supplied with cabbages, lettuces, carrots, turnips, parsnips, artichokes, kidney-beans, green pease, asparagus, and various sorts of European herbs, in the greatest abundance. Other indigenous productions, that may be classed among the esculent vegetables, are plantains, bananas, yams of several varieties, calalaa (a species of spinach), eddoes (*Arum* and *Caladium*), cassavi, and sweet potatoes. Among the more elegant fruits of the island we may reckon the anana, or pine-apple, tamarind, papaw, guava, sweet-sop, cashew-apple, custard-apple, Akee tree (fig. 200.),



cocoa-nut, star-apple, grenadilla, avocado-pear, hog-plum, pindal-nut naesberry, mammee-sapota, Spanish gooseberry prickly-pear, anchovy-pear (fig. 201 a.), and some others, for which Jamaica is probably indebted to the bounty of nature. For the orange, the lemon, lime, shaddock, vine, melon, fig, and pomegranate, the West India islands are perhaps obliged to their Spanish invaders. The cinnamon has been lately introduced, and the mango (fig. 201 b.) is become almost as common as the orange. The mountains are generally covered with extensive woods, containing excellent timber; such as the lignum vitæ, log-wood, iron-wood, pigeon-wood, green-heart-braziletto, and bully-trees; all of which are to a great degree heavy, as well as compact and impenetrable. Of softer kinds, for boards and shingles, the species are innumerable; and there are many beautiful varieties for cabinet-work; and among these we may enumerate the bread-



nut, the wild lemon, and the well-known mahogany.

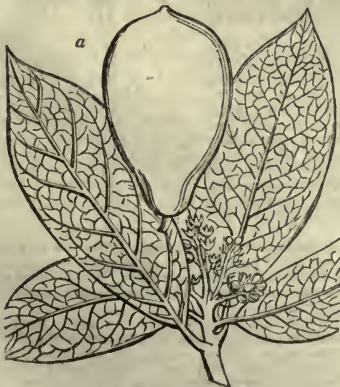

201



1187. *The culture of the sugar-cane in Jamaica* in some respects resembles that of the hop in this country. The ground being cleared and worked a foot or more in depth, the sets or cuttings of cane, which are the tops of the shoots cut off about a foot long, are planted in rows, generally five feet distant, and from two to five feet apart in the row, according to the quality of the soil; more plants being allowed for poor soil than rich. The ground is kept clear of weeds, frequently stirred, and some earth drawn up to the plants. From each hill a number of shoots are produced: in six or more months these will generally be from seven to ten feet high; the skin smooth, dry, and brittle, heavy with a gray or brown pith, and sweet glutinous juice. In this state the canes are cut, tied in bundles or sheaves, and taken to the mill to be divested of their leaves and decayed parts, and then passed through rollers to express their juice, &c. Cane plantations are made twice a-year, in May and June, or December and January, these being the rainy seasons. The first cutting of the canes often does not take place till a year after planting; but an established plantation is cut over every six months. In good soil, the plants will last twenty years: in inferior soils not more than half the time. (*Lett. to a Young Planter, &c. Lond. 1785. Martin's Essay on Plantership, in Young's Annals, xviii. p. 236. Roughley's Jamaica Planter's Guide, 1823.*)

1188. *The cotton plant cultivated in Jamaica* is a different species from that grown in Italy, Malta, and the Levant. It is the gossypium barbadense, Linn. a suffruticose biennial, growing from six to fifteen feet in height, with lobed leaves and yellow flowers. It is propagated by the seed, which is set in rows, about five feet asunder, at the end of September, or beginning of October; at first but slightly covered, but after it is grown up, the root is well moulded. The seed is subject to decay, when it is set too deep, especially in wet weather. The soil should not be stiff nor shallow, as this plant has a tap-root. The ground is hoed frequently, and kept very clean about the young plants, until they rise to a moderate height; otherwise they are apt to be destroyed by caterpillars. It grows from four to six feet high, and produces two crops annually; the first in eight months from the time of sowing the seed; the second, within four months after the first; and the produce of each plant is reckoned about one pound weight. The branches are pruned or trimmed after the first gathering; and if the growth is over-luxuriant, this should be done sooner. When great part of the pods are expanded, the wool is picked, and afterwards cleared from the seeds by a machine called a gin, composed of two or three smooth wooden rollers of about one inch diameter, ranged horizontally, close and parallel to each other, in a frame; at each extremity they are toothed or channelled longitudinally, corresponding one with the other; and the central roller, being moved with a tradel or foot-lath, resembling that of a knife-grinder, makes the other two revolve in contrary directions. The cotton is laid, in small quantities at a time, upon these rollers, whilst they are in motion, and, readily passing between them, drops into a sack placed underneath to receive it, leaving the seeds, which are too large to pass with it, behind. The cotton thus discharged from the seeds, is afterwards hand-picked, and cleansed thoroughly from any little particles of the pods or other substances which may be adhering to it. It is then stowed in large bags, where it is well trod down, that it may lie close and compact; and the better to answer this purpose, some water is every now and then sprinkled upon the outside of the bag, the marketable weight of which is usually three hundred pounds. An acre may be expected to produce from two hundred and forty pounds to that quantity, or two hundred and seventy pounds on an average. (*Long's Jam. vol. iii. p. 686, &c. and Browne.*)

1189. *The indigo cultivated in the West Indies* is the same species as that grown in the East Indies and other places (*Indigofera tinctoria*), though there are various species and varieties which afford a similar dye. Indigo thrives best in a free rich soil, and a warm situation, frequently refreshed with moisture. Having first chosen a proper piece of ground, and cleared it, hoe it into little trenches, not above two inches, or two inches and a half in depth, not more than fourteen or fifteen inches asunder. In the bottom of these, at any season of the year, strew the seeds pretty thick, and immediately cover them. As the plants shoot, they should be frequently weeded, and kept constantly clean, until they spread sufficiently to cover the ground. Those who cultivate great quantities, only strew the seeds pretty thick in little shallow pits, hoed up irregularly, but generally within four, five, or six inches of one another, and covered as before. Plants raised in this manner are observed to answer as well, or rather better, than the others; but they require more care in the weeding. They grow to full perfection in two or three months, and are observed to answer best when cut in full blossom. The plants are cut with reaping hooks, a few inches above the root, tied in loads, carried to the works, and laid by strata in the steeper. Seventeen negroes are sufficient to manage twenty acres of indigo; and one acre of rich land, well planted, will, with good seasons and proper management, yield five hundred pounds of indigo in twelve months, for the plant ratoons (stools, stoles, or tillers; *i. e.* it sends out stolones, or new growths), and gives four or five crops a-year; but must be replanted afterwards. (*Browne.*)

1900. *The coffee-tree* (*fig. 202*), is less cultivated in Jamaica than in Barbadoes, Domingo, and some other islands: the richness of the soil is found to lessen the flavor of the berry, when compared with those produced in the sandy, dry, hot soil, and arid climate of Arabia. In a rich soil and cool situation in Jamaica, Browne informs us that it produces so great a quantity of fruit, that the branches can hardly sustain the weight; the fruit large and succulent, and the berries lax and clammy. Some affirm, that by keeping these, and other West India berries, for ten or fourteen years, they will become equal to the best now brought from Turkey. Small-grained coffee, or that which is produced in a dry soil and warm situation, will in about three years be as good as that in general use in London.

1191. *In cultivating the coffee*, the berries are sown immediately after being gathered, as they are found to retain their vegetative quality only a few weeks. In three months they are fit to transplant, either to a nursery or to a final plantation. In the low lands they are planted five feet apart, and in the mountains ten feet or more. In three years the plants will produce a crop, and continue bearing a number of years. The berries are gathered when they are just about to drop; and are immediately carried to sheds, where they are dried upon cloths or mats, till the husk shrivels. They are then passed through between wooden rollers turned by a mule, which separates the husk, after which they are winnowed, sifted, cleaned, exposed to the sun for a few days, and then barrelled up for sale. The produce of a good tree is from one pound and a half to two pounds weight. (*Browne's Hist. of Jam. p. 161.*)

1192. *The cocoa-root or eddoe*, (*Arum esculentum*) and also a species of caladium, produce a root something like the Indian yam (*Dioscorea sativa*, *fig. 203.*), but differ from them in lasting for several years. Both the cocoa root and yam are cultivated much in the same way as our potatoe. They have what they call Bourbon cocoas and country cocoas, and Negro and white yams; the yams have a stake driven in at each hill for the vines to twine on after the manner of hops.

1193. *The plantain* (*Musa paradisiaca*) is cultivated in rows ten feet apart, and the plants seven feet asunder in the row. The following account of the manner of planting and managing will give some idea of the mode in which agricultural operations are carried on by a slave population, and how they are described by a writer who has been "nearly twenty years" at the business. "The ground being all cleared from grass, bushes, and weeds, and lined out and pegged every seven feet, the great gang should be put in with hoes to dig the plantain holes at every peg, a Negro to each row. The holes should

202





be dug deep, two feet long by sixteen inches broad, to give room for the large ponderous plantain sucker to be placed in them. The mould must be hauled up to the edge of the hole, and broke if too large. The plantain suckers being ready and trimmed, each negro should take some, and place one good sucker at every hole in the piece, and begin to plant them, by taking a sucker, and placing it with the butt, or rooty end, in the bottom of the hole; make the sucker lie in a leaning, reclining, or half horizontal position in the hole, with the small, or sucker end of the plant, a little above the ground; and when thus placed, draw the mould from the bank, and cover the plant well with it, leaving a little of the plant above the ground. In this manner the plantain walk should be formed. In a few weeks (if the weather is favorable) the young plantain-shoot will be seen rearing its perpendicular head, perhaps three or four growing from the same stock. They should then be carefully moulded, and cleared of grass and weeds when they are a few inches high. No cavities, or water-logging holes, should be near them. The banks must be levelled about them, the holes filled, and properly closed up, and some fine mould given them, to encourage their growth. There will be no occasion to give them more than two mouldings till they are established; but they must be carefully kept clear from weeds or grass; and when any dry trash happens to be hanging about them, it should be gently cut off with a knife, and placed about their roots, to keep them either free from too much sun or chill. A plantain-walk, well taken care of, will be in bearing twelve months after it is planted, amply repaying for the labor and trouble of planting it, and giving an almost inexhaustible supply of fine provisions, if the vicissitudes of hurricanes or storms (which this climate is unhappily subject to) does not destroy it, and which no human foresight or care can prevent. When a plantain-walk is made, there may be a row of coconuts (1192.) in the middle of the ten feet spaces, which will yield a crop by the time the plantain-walk bears fruit, but they must then be pulled up. A few banana (*Musa sapientum*) suckers can be planted in the plantain-row, instead of plantain-suckers; sometimes they are much in request, as a luscious, wholesome fruit, and for the strong, fine-flavored vinegar which is produced from them. After this piece of ground is thus planted, the whole of it may be sown with corn (maize), which will not injure the plantain-suckers, or trees, if it is not too close or thick. (*Roughley*, p. 413. 416.)



1194. *The Indian arrow-root* (*Maranta arundinacea*) is cultivated, and yields an annual supply of roots, which being washed, bruised, and compressed, yield a starch esteemed as a very light wholesome food for invalids.

1195. *Other plants*, in great variety, are cultivated both for culinary and medicinal purposes, and in the gardens of the overseers and agents almost every fruit in the world may be raised.

1196. *The penguin* (*Bromelia penguin*) is grown on the tops of ditches, and forms an impenetrable fence.

1197. *Maize* is grown among the canes, and in fields by itself in rows, four feet and a half apart, and the corn dibbled or set in patches of four seeds in a space six inches square.

1198. *Guinea grass* (*Panicum polygonum*, fig. 199 b.), and *Scotch grass* (fig. 199 a.), are the clovers or artificial herbage plants of Jamaica. They are perennial, and grow in small enclosures, which are either eaten down or mown. Cane tops, the leaves of maize, millet, and a variety of other herbage, is given to the mules or cattle.

1199. *Rats, ants, and other vermin*, greatly annoy the canes: ticks (æstrus?) of different kinds, and flies, greatly annoy the cattle, and a great variety of evil propensities and diseases assail the negroes and their children: among others *Obea*, and what *Roughley* calls "eating dirt," which he thus characterises: — "Too much tenderness gives the child a fretful longing for the mother, and her scanty milk engendering disease, and, what is worse than all, often (though secretly) giving it a growing liking for the hateful, fatal habit of eating dirt, than which nothing is more horribly disgusting, nothing more to be dreaded, nothing exhibiting a more heart-rending, ghastly spectacle, than a negro child possessed of this malady. Such is the craving appetite for this abominable custom, that few, either children or adults, can be broken of it, when once they begin to taste and swallow its insidious slow poison. For if by incessant care, watchfulness, or keeping them about the dwelling-house, giving them abundance of the best nourishing food, stomachic medicines, and kind treatment, it is possible to counteract the effects and habit of it for some time, the creature will be found wistfully and irresistibly to steal an opportunity of procuring and swallowing the deadly substance. The symptoms arising from it are a shortness of breathing, almost perpetual languor, irregular throbbing, weak pulse, a horrid cadaverous aspect, the lips and whites of the eyes a deadly pale (the sure signs of malady in the Negro), the tongue thickly covered with scurf, violent palpitation of the heart, inordinate swelled belly, the legs and arms reduced in size and muscle, the whole appearance of the body becomes a dirty yellow, the flesh a quivering pellucid jelly. The creature sinks into total indifference, insensible to every thing around him till death at last declares his victory in his dissolution. This is no exaggerated account of the effects and termination of this vile and hateful propensity. (*Ib.* 118. 120.)

1200. *The agriculture of the other West India islands* may be considered as similar to that of Jamaica. So many different kinds of East India fruits have not yet been introduced in them; but the great articles of sugar, coffee, cotton, indigo, pepper, &c. are every where cultivated. One of the richest of these islands is *St. Domingo*, now independent, and known by its original name of *Hayti*.

SECT. IV. *Present State of Agriculture in South America.*

1201. *The climate of South America* combines the most opposite extremes. The southern parts are subject to all the horrors of the antarctic frosts; Terra del Fuego being subject to the almost perpetual winter of Greenland. Even under the torrid zone the cold is extreme on the Andes, and the heat and moisture equally extraordinary in the plains. The surface of the country is remarkably irregular: there are immense chains of mountains which stretch along the western coast from the one extremity of the country to the other. Many parts of the interior are still obscure; wide regions on the great river of Amazons being covered with impenetrable forests, and others flooded by the inundations. In the south there are vast saline plains, and small sandy deserts and savannahs. This country being, or having been, almost entirely under the Spaniards and Portuguese, the cultivated parts display a slovenly agriculture, something like that of Spain; the varied and abundant products of the soil depending more on nature than on man. Indeed minerals have always been more the objects of European nations in South America than vegetables. — After this general outline we shall, without regard to the recent political changes, offer such slight notices of South American agriculture as we have been able to collect, under the divisions of Terra Firma, Peru, Chili, Paraguay, Brazil, Cayenne, Surinam, Amazonia, and Patagonia.

1202. *The climate of Terra Firma* is extremely hot throughout the year. From the month of May to the end of November, the season called winter by the inhabitants, is almost a continual succession of thunder, rain, and tempests; the clouds precipitating the rain with such impetuosity, that the low lands exhibit the appearance of an ocean. Great part of the country is of consequence almost continually flooded; and this, together with the excessive heat, so impregnates the air with vapors, that in many of the provinces, particularly about Papayan and Portobello, it is extremely unwholesome. The soil of this country is very different, the inland parts being exceedingly rich and fertile, while the coasts are sandy and barren. It is impossible to view, without admiration, the perpetual verdure of the woods, the luxuriancy of the plains, and the towering height of the mountains. This country produces corn, sugar, tobacco, and fruits of all kinds; the most remarkable is that of the manzanillo tree; it bears a fruit resembling an apple, but which, under this appearance, contains a most subtle poison. The bean of Carthagena is the fruit of a species of willow, about the bigness of a bean, and is an excellent remedy for the bite of the most venomous serpents, which are very frequent all over this country.

1203. *In Peru* the soil is dry, and has no rain, vegetation being supported by immense dews. The only spots capable of cultivation are the banks of the rivers, and other places susceptible of being artificially irrigated. The improvement of the mines is or ought to be the first object of attention in this singular country.

1204. *Chili* is an extensive, rich, and fertile country. The climate is the most delicious in the new world, and is hardly equalled by that of any region on the face of the earth. Though bordering on the torrid zone, it never feels extreme heat, being screened on the East by the Andes, and refreshed on the west by cooling sea-breezes. The temperature of the air is so mild and equable, that the Spaniards give it the preference to that of the southern provinces in their native country. The fertility of the soil corresponds with the benignity of the climate, and it is wonderfully accommodated to European productions. The most valuable of these, corn, wine, and oil, abound in Chili, as if they had been native to the country. The soil, even that part of it which has been long in tillage, is so little degenerated by producing successive crops, that no manure is necessary. The grain, as some say, yields from 100 to 150; but by a more moderate and just estimate, as it is stated both by Molina and in Peyrouse's *Voyage*, from 60 to 70 in the midland country, and in the maritime 40 or 50.

1205. *Many of the plants of Chili are the same with those of Europe*, and almost all the pot-herbs and fruits of our continent flourish there. The northern provinces produce the sugar-cane, the sweet potatoe, and other tropical plants. Maize is common and abundant; the magu is a kind of rice, and the tuca a species of barley, both of which were cultivated before the arrival of the Spaniards. Pease and potatoes were also well known to the Chilese. Of the latter they have thirty different kinds: and it is even conjectured that this valuable root was first brought into Europe from this country. The large white strawberry of Chili is well known in English gardens. Many of its plants are valuable as dyes, and others as medicinal. The vira-vira expels the ague; the payco is excellent for indigestion. Wild tobacco abounds in Chili, and also the annotto (*Bixa orellana*, fig. 204.) The beautiful flowers and shrubs are infinite. Incense, not inferior to that of Arabia, is produced by a shrub, distilling tears of a whitish yellow, and of a bitter aromatic taste. The trunk of the puví supplies excellent cork; the salsola kali is plentiful on the shores; and Chili produces seven kinds of beautiful myrtles, one of which yields an excellent stomachic wine preferred by strangers to any muscatel. The crelon furnishes



a tea, which is known as a verfruge. An acacia of the province of Quillota yields a balsam, that is used in the cure of wounds; and the palqui is esteemed as a febrifuge, superior to the Peruvian bark. The cassia senna grows on the banks of the rivers Maypo and Salvia. Of ninety-seven kinds of trees that diversify the beautiful forests of Chili, only thirteen lose their leaves in winter. Cypressess, pines, and red and white cedars grow in the valleys of the Andes; the red cedars, particularly in the isle of Chiloe, are of an enormous size, so that from 700 to 800 planks, twenty feet long, may be cut from one tree. The cinnamon-tree, that yields what is called winter's bark, is regarded as sacred by the Araucans, who present it as a token of peace. Beautiful woods of various colors are supplied by the Chilese forests. Vines, though none appear to be natives, flourish admirably well: they are found in the forests, arising from seeds deposited by the birds: on the confines of the river Mauli they are three or four feet high, and supported by stakes; but further to the south they are left loose on the sides of the hills. The best wine is that which is obtained from the banks of the river Itati, and is commonly called wine of Conception; it is red, generous, of an excellent flavor, and equal to the best in Europe. Muscatel wines are also excellent. The vintage is April and May. All the other European fruits attain the greatest perfection. Most of the European animals have improved in this delicious climate and fertile country. The celebrated Spanish sheep have not lost any of their distinguished qualities; the horned cattle are larger than those of Spain; and the breed of horses surpasses both in beauty and spirit the famous Andalusian race from which they spring.

1206. *Paraguay* is a fertile province, and singularly prolific in native vegetables. The climate is extremely hot: the surface of the country consists generally of extensive plains; but some tracts are very mountainous. The soil is every where rich and deep; and the native pastures so excellent, that the immense herds of wild oxen which feed on them are only valued for their skins; the flesh being left to be consumed by ravenous beasts and birds. Among the agricultural products may be mentioned the potatoe, of which they have several sorts of a large size, red, white, and yellow cotton, maize, wheat, and the vine. The latter is greatly injured by the ants; but where that insect is kept under, the wine of Paraguay is excellent. The bean, pea, melon, cucumber, lettuce, turnip, mustard, cress, leek, onion, asparagus, and other European vegetables are found wild in the plains. The forests abound in the most valuable trees, among which is the cinchona, or Jesuits' bark, so called because the society of Jesus settled there had originally the monopoly of this medicine: the sarsaparilla, sassafra, guaiacum, dragon's blood, nux vomica, vanilla, theobroma, or chocolate plant (*fig. 205.*), several species of the ceratonia, the seeds of which are ground and made into bread. Palms, figs, peaches, pomegranates, lemons, oranges, are cultivated; and the jujube, mulberry, granadilla, banana, pine-apple, and a great variety of other fruits, are found in a wild state. Of the live stock, the most abundant are the ox and the camel; but there are horses, asses, sheep, many wild swine (*fig. 206.*), and poultry. The bear, elk, deer, ostrich, and others, are in a wild state.

205



1207. *Brazil* is a country growing fast into opulence and importance. Its climate has been described by two eminent naturalists, Piso and Margrave, who observed it with philosophical accuracy, as temperate and mild, when compared with that of Africa. This they chiefly ascribe to the refreshing wind which blows

continually from the sea. The air is not only cool, but chilly through the night, insomuch that the natives kindle fires every evening in their huts. Nieuhoff, who resided long in Brazil, and Spix and Martius, recent travellers, confirm their description. The rivers in this country annually overflow their banks, and, like the Nile, leave a sort of slime upon the lands; so that the soil, especially in the vicinity of the rivers, is extremely rich. The northern provinces are subject to heavy rains and storms; but those of the south are more temperate and fertile.

206



1208. *Among the vegetable productions of Brazil,* we may reckon Indian corn, wheat, rice, manioc, sugar-canes, coffee, cocoa or chocolate, indigo, pepper, cactus, on which is bred the insect furnishing cochineal, and the noted Brazilian tobacco. The red, or Brazil wood, imported into this country, for the purpose of dyeing, is the property of the crown. To the class of esculent plants, we may refer those that are common to all the tropical regions of America, such as, besides the cocoa and chocolate nut, the plantain, the banana, palms, the yam, potatoe, casava, together with many species of melons and gourds. The principal fruits are the pine-apple, the mango, and the tamarind. The warm aromatic plants found here in a truly indigenous state, and much used by the inhabitants as condiments to their food, or as the basis of various drinks, are the oranges and limes (*fig. 207.*), the grapes, ginger, the turmeric, several species

207



of pepper, American coffee, capsicum or Guinea pepper, and the wild cinnamon (*Laurus canella*). Several medicinal plants of high estimation grow here spontaneously, and in great abundance, such as the contrayerva, the Indian pink, the mechoacan, the jalap, the amyris which yields the gum elemi, and the guaiacum. Besides the Brazil wood, this country furnishes for ornamental use, or for the purpose of dyeing, logwood, fustic, mahogany, ebony, rose-wood, satin-wood, and many others. Among its ornamental plants are the Brazilian myrtle, the scarlet fuchsia, and the amaryllis formosissima.

1209. *The genuine Ipecacuanha root (Cephaelis ipecacuana)* grows wild in groups on the woody mountains of Serra de Mar, north from Rio de Janeiro to Bahia. The roots are pulled up by the negroes in the rainy season, dried in the sun, tied in bundles, and sold to the dealers of roots in Rio. The savages use an infusion of these roots as a vomit, much in the same way as we do. (*Spix and Martius' Travels in Brazil*, ii. 221.)

1210. *The pot tree (Lecythis allaria)* is one of the greatest ornaments of the woods; its immense stem is above a hundred feet high, and spreads into a majestic and vaulted crown, which is extremely beautiful in the spring when the rose-coloured leaves shoot out, and in the flowering season, by the large white blossoms. The nuts, which have a thick shell, are of the size of a child's head, with a lid which is loose all round, and which at length, when the weight of the fruit turns it downwards, separates, and lets the seed fall out. In a high wind it is dangerous to remain in the woods on account of these heavy nuts falling from so great a height. The seeds are collected in great quantities by the Indians, who are extremely fond of them, and either eat them raw, or preserve them roasted and pounded, in pots, and the shells themselves are used as drinking cups. (*Spix*, vol. ii. p. 222.)

1211. *Several species of Bromelia*, or Paulinia, afford thread called gravata and imbé, which is prepared by maceration as in Sicily from the Agave Americana, and wove into cloth, or twisted into ropes and cordage.

1212. *Mandioca (Jatropha)* is cultivated for the flour made from its roots: the Mandubi bean, for its seeds: Paraguay tea, which is used as a substitute for that of China, and broad beans, tobacco, maize, and other plants of Europe.

1213. *The live stock of Brazil* are chiefly horned cattle, which are abundant, and hunted merely for their hides: of these hides 20,000, it is said, are annually sent to Europe. These cattle are taken and killed more for the sake of their hides and tallow than their flesh; though great quantities of the latter are applied to the use of such ships as sail from Pernambuco, Bahia, Todos os Santos, and Rio de Janeiro, to Guinea. The places which are chiefly frequented for procuring these cattle are Rio Grande and Rio Paraiba, lying to the northward of Pernambuco; and they are inhabited by Indians, called 'Iapuyes; many of whom send annually large droves of cattle through the Tupipue nation.

1214. *The musk, ox, deer, bear, hog, hare*, and other useful animals, abound in the forests; and there is some danger also from those of a noxious description, to guard against which the natives light fires, 208 and when they can afford it sleep in hammocks suspended from the trees. (*fig. 208.*)

1215. *Cayenne or French Guiana*, is a fertile country, and has been long well cultivated by the colonists. The climate is salubrious; the surface of the country is not mountainous, but abounds in hills and forests; the soil is in general uncommonly fertile; and the productions it yields are of excellent quality.

The Cayenne pepper (*Capsicum annum*, and other species) is a noted produce of this country, and with sugar, cocoa, coffee, indigo, maize, cassia, and vanilla, form the chief articles of its commerce. The interior parts, though much neglected, and remaining obstructed by thick forests and underwood, feed nevertheless a great number of horses, sheep, goats, and cattle, which roam at pleasure: the beef and mutton are reckoned excellent. (*Maison Rustique de Cayenne*, &c., Paris, 1763.)

1216. *Surinam* is a low moist country, which has been in part studded with wooden houses, (*fig. 209.*) and well cultivated by the Dutch. The climate is hot, but tempered by the sea breeze. The

surface of the country is little varied by inequalities. The uncultivated parts are covered with immense forests, rocks, and mountains; some of the latter enriched with a great variety of mineral substances; and the whole country is intersected by very deep marshes or swamps, and by extensive heaths or savannas. The soil is, in general,

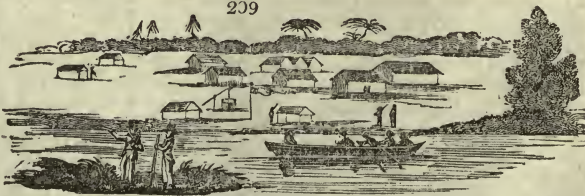

very fertile; and all the appearances of fertility may be ascribed, not only to the rains and warmth of this climate, but also to the low and marshy situation of the country, which prevents the intense heats from destroying vegetation, and to the extreme richness of the soil, particularly in those parts that are cultivated by European industry.

1217. *The principal products of Surinam* are tobacco, sugar, coffee, cocoa, cotton, and indigo. The Quasia tree, or bitter drug, used by the porter brewers, grows wild in the woods, and was first exposed for sale by a native called Quas, after whom the tree is named. The cabbage tree is abundant, and besides the tender leaves produces a beetle (fig. 210 a.) the larva of which (b) is eaten by the natives as a luxury.

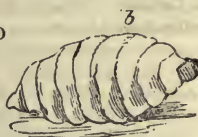

A very interesting account of this colony is given by captain Stedman, (*Journal, &c.* 2 vols. 4to. 1794.) who filled an important military situation there for several years. This gentleman, in the midst of the most arduous duties, contrived to make himself tolerably comfortable. He built a country house there (fig. 211.); kept a wife, pigs, bees, sheep, and cattle, and had children and slaves. He lived by turns with his family in a house, and with strange women in the woods, where he slept in hammocks (fig. 212.) and adopted many of the practices of the natives. He made many sketches, and kept a journal; and after many years full of

211

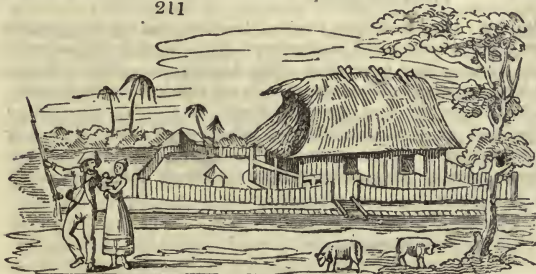

interesting adventures with the rebellious natives, and of endearing scenes with Joanna

212

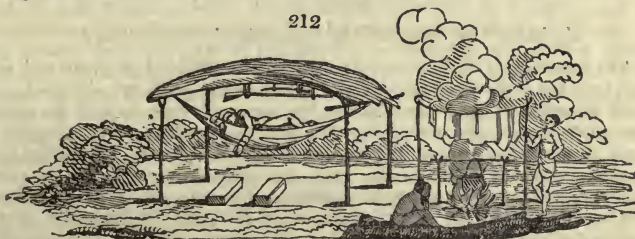

his local wife, he came home and wrote a very entertaining account of what he had seen and done. (See *Stedman's Surinam*, 2 vols. 4to. 1794.)

1218. *Amazonia* is an extensive, unconquered, or at least uncivilized country. In so far as it is known, its climate is more temperate than might be expected from its geographical position. The surface of the country is clothed in most places by interminable forests, and its immense river is well known. The soil of a small settlement formed by the Portuguese, is very fertile, and produces corn, grain, and all kinds of tropical fruits; besides a variety of timber, as cedar, brazil-wood, oak, ebony, iron-wood, log-wood, and other dyeing woods; and also cocoa, tobacco, sugar-canes, cotton, cassava root, potatoes, yams, sarsaparilla, gums, raisins, balsam of various sorts, pine-apples, guavas, bananas, &c. The forests abound with wild honey, and also with tigers, wild boars, buffaloes, deer, parrots, and other curious birds (fig. 213.), and game of various kinds. The rivers and lakes afford an ample supply of fish, sea-cows, and turtles; but the alligators and water serpents render fishing a dangerous employment. The trees, fields, and plants, are verdant throughout the year.

213



1219. *Patagonia* consists for the greatest part of open deserts and savannahs, with a few willow trees on the rivers. It seems to enjoy a temperate, but rather cool climate; but separated in the middle by the vast mountains of the Andes, one part of it differs widely from the other. To the northward of La Plata, this part of South America is covered with wood, and stored with an inexhaustible fund of large timber: but to the southward of that river, the eye can scarcely discover a single tree or shrub fit for any mechani-

cal purpose; but even this seemingly barren country has some good pastures, and numerous droves of wild horned cattle, and every district abounds with horses, which are supposed to have been brought hither by the Spaniards.

1220. *Of the south American islands*, that of Juan Fernandez abounds in pasture, cattle, and woods; and Terra del Fuego, amidst its horrible snows, exhibits a variety of plants. The Falkland islands contain a variety of fowls and plants, somewhat resembling those of Canada. Georgia is a field of ice, in which, or in any of the other islands, there is no cultivation whatever.

---

## BOOK II.

### AGRICULTURE AS INFLUENCED BY GEOGRAPHICAL, PHYSICAL, CIVIL, AND POLITICAL CIRCUMSTANCES.

1221. *Agriculture, considered in regard to climate, territorial surface, and society*, presents some features, which it may be instructive to recognize. Whoever has perused with attention the outline which we have now concluded of the field culture of the different nations of the world, must have a general and enlarged view of that art; and must necessarily have observed, that there are different species of territorial culture, founded on difference of geographical position or climate; difference of physical circumstances or surface, and differences of civilization or human wants. The object of the present Book is to characterize these different species, and to refer to them the proper districts throughout the world.

---

### CHAP. I.

#### *Agriculture as influenced by Geographical Circumstances.*

1222. *The influence of climate* extends not only to the kind of plant and animals to be cultivated, but to the mode of culture. A few useful plants are universal, and but a few. Of those belonging to agriculture, we may enumerate most of the pasture or hay grasses which are annuals, and of the cereal grasses, the wheat, rye, and barley. The oat, the pea, bean, turnip, potatoe, and the perennial pasture grasses, will neither thrive in very hot, nor in very cold climates; the maize, millet, and rice can only be grown in warm countries, and the oat in temperate regions. The roots and fruits of what are denominated hot climates, as the yam, plantain, bread-fruit, &c. are limited to them; and equally so the timber trees of temperate and torrid regions, as the oak and pine, the mahogany or teak-tree.

1223. *Animals as well as plants* are similarly affected by climate. Some animals are universal, as the ox and swine, which are found in every latitude; others are limited in their range, as the rein-deer, camel, elephant, and, considered as a cultured animal, the sheep. The horse and ass are nearly universal, but cannot be substituted for the rein-deer. The sheep will exist in India and also in Greenland, but lose their useful character in both countries; in Greenland they require protection during nine months of the year, and in India their wool is changed to hair, and the carcase is too lean for the butcher.

1224. *The culture* required for both plants and animals depends materially on climate. It is not easy for a person who has never been out of Britain to conceive a just idea of the aquatic culture even of Italy or Spain. In these countries though most crops, whether of grain or roots, require watering, yet some in the rainy season may be obtained in the usual way, as melons in Italy and onions in Spain. But in Arabia, Persia, and India no culture can be undertaken without water, excepting in the upper regions of mountains. The fundamental process of culture in these countries is to prepare the surface for the reception of water, and its circulation in trenches and gutters, and to procure the water by raising it from wells or rivers by machinery. Wherever the surface cannot be irrigated, no regular culture need be attempted or corn crop expected. Nature in such situations produces periodical crops of annual succulents or bulbous rooted plants; and man might, perhaps, to a certain extent, turn this circumstance of climate to account, by changing the sorts of annual bulbs, &c. from such as are useless, to such as are useful. The onion or edible crocus or cyperus might, perhaps, be substituted for the ixia of the Cape; and the sesamum, or some rapid annual, furnishing useful seeds or

herbage, for numerous annual weeds, and the cochineal cactus for the shewy but useless *Mesembryanthemums* and *Stapelias* of the African wastes. These, however, are only suggestions.

1225. *Culture in the north of Europe* depends for the most part more on draining lands of their superfluous water, than on artificial supplies of that element. When irrigation is applied it is limited entirely to grass lands; and that not for the purpose of supplying such lands with moisture, but for stimulating by manure held in solution by the water, and for increasing or maintaining heat. The greatest care is requisite to prevent this mode of watering from proving more injurious than useful; but little danger results from the application of water in hot countries, and there it is valuable by moderating rather than increasing the temperature of the soil. Water in the north of Europe is generally supplied in more than sufficient quantity by the atmosphere; and therefore one great object of the cultivator is to keep the soil thoroughly drained by surface gutters and subterraneous conductors; to keep it pulverized for the moisture to pass through; and the roots to extend themselves; well stocked with manure to supply nourishment; freed from weeds, to prevent any of this nourishment from being wasted; and to admit the light, air, and weather to the useful plants. In the hot countries keeping the soil free from weeds is generally a duty easily performed, and often rendered unnecessary; for whenever water is withheld even in the south of Spain (724.), every living thing is burned up with drought. It is remarkable that in the most northerly parts of Europe and America the same effect, especially as to fibrous rooted perennials, is produced by cold, and in Russia and New England, where there is scarcely any spring, the agriculturist has only to plough once, and sow in the same way as in the hot valleys of the south of Spain, and South America, where vegetation is equally rapid from the accession of moisture as it is in the cold plains of Russia from the influence of the sun during the long days of a northern summer. In hot countries putrescent manures are not altogether neglected, but they are much less necessary than in cold countries, and can be done without where there is abundance of water;—there water, intense heat, and light, a consequent moist atmosphere, and a well pulverised soil, supply every thing necessary for luxuriant vegetation.

1226. *Hence it is that agriculture considered geographically admits of two grand divisions*, that of the cold climates, which may be called agriculture by draining and manures; and that of the hot climates, which may be called agriculture by irrigation. To the former belongs the greater part of Europe, the north of Asia, the north of America, and part of the Australasian isles; to the latter, Egypt, Persia, India, China, Africa, and great part of the south of America, and part of Australasia. As intermediate between agriculture by watering, and agriculture by draining, may be mentioned that *mixed culture by watering and manuring* which prevails in the south of France, Spain, and Italy; and as opposed to the aquatic culture of the torrid zone may be placed the rural economy of the arctic circle, which, from the prevalence of cold and ice, precludes all culture of the soil, admits little else than the growth of mosses and lichens, and is therefore limited to fishery and the chase.

1227. *These leading divisions of culture are by no means so absolute as to be determinable by degrees of latitude*, so much depending on physical circumstances; as elevation, soil, aspect, island, or continent, &c.; but as an approximation which may impress some general ideas in the mind of the practical agriculturist, we submit the following:

1228. *The agriculture of irrigation* may be considered as extending thirty-five degrees on each side of the equator.

1229. *The agriculture of manures and irrigation* from the thirty-fifth to the forty-fifth degree north and south of the equator.

1230. *The agriculture of draining and manures* from the forty-fifth degree, north and south of the equator, to the sixty-seventh degree or arctic circle.

1231. *The arts of fishing and hunting*, as the only means of subsistence, from the sixty-seventh degree, or arctic circle, to the pole.

---

## CHAP. II.

### *Agriculture as influenced by Physical Circumstances.*

1232. *The physical circumstances which principally affect agriculture* are temperature and light, elevation, moisture, and soil.

1233. *Temperature and light* have the most powerful influence on the culture both of plants and animals. Elevation, when not considerable, admits of being rendered subservient to the processes of culture, and to the habits of different plants and animals;

moisture may be moderated or increased, soil improved; but temperature and light are in a great measure beyond human control. Hence it is that the plants and animals cultivated by the agricultor, do not altogether depend on his skill or choice, but on his local situation. Not only the maize, rice, and millet, which are such valuable crops in Asia and Africa, cannot be cultivated in the north of Europe, but even within the extent of the British isles, some kinds of grain, pulse, and roots, cannot be grown to such perfection in certain districts as in others. Thus the Angus variety of oat will not come to the same perfection, south of London, that it does north of York; and of different varieties the Dutch, Polish, and potatoe oat will succeed better in a warm climate, than the Angus, black, or moorland oat, which answer best for cold, moist, and elevated districts. The turnip arrives at a greater size in Lancashire, Berwickshire, and Ayrshire, than it does in Kent, Surrey, or Sussex, even admitting the best possible management in both countries. The pea requires a dry soil and climate, and more heat than the bean, and consequently thrives much better in the south of England, in Kent, and Hampshire, than in Scotland or Ireland. It is certain that the perennial grasses thrive best where the temperature and light is moderate throughout the year, as on the sea-coast in various countries, where mildness is obtained from the influence of the sea, and light from the absence of a covering of snow; and also in the south of England, where the snow seldom lies, and where the temperature is moderate, and the nights not so long as they are farther north. It is equally certain that in America and Russia, where the cold is intense during winter, and the plants on the surface of the ground are deprived of light for six or seven months together by a covering of snow, all herbaceous vegetation is destroyed. Contrasted with these facts, may be mentioned as equally well ascertained, that annual plants in general attain a greater size, and a higher degree of perfection, where the winters are long, and the summers hot and light; the reason of which seems to be that the alternate action of heat and cold, rain and ice, meliorates the soil and prepares it better for the nourishment of annuals than it can well be in countries where the soil is not only harder naturally, (for all countries that have long winters have soft soils,) but more or less occupied by perennial weeds, insects, and vermin. In cold countries the insects are generally of that kind whose eggs go through the processes of the larva and chrysalis state under water, and land reptiles are generally rare.

1234. *Elevation*, when considerable, has an absolute influence on agriculture. The most obvious effect is that of obliging the agriculturist to isolate his dwelling from those of other cultivators or villagers in the plains, and to reside on his farm. This is well exemplified in Switzerland and Norway. We have already noticed the judicious reflections of Bakewell on the subject as referable to the former country (336.), and have also referred to those of Dr. Clarke respecting Norway (591.). The latter author has depicted these alpine farms, both with his elegant pen and habile pencil (*fig.* 214.). The



farmeries are generally built with fir planks, and covered with birch bark, and turf. The inhabitants chiefly live by the dairy, and seldom see their neighbours or any human being beyond their own fire-side, excepting on the Sunday morning when they go to church, and on the Sunday afternoons in summer when they meet to dance (*fig.* 215.), and amuse themselves.



1235. *As elevation is known to lessen temperature* in regular gradation according to the altitude above the sea, its influence on plants and animals must correspond. Three hundred feet in height are considered nearly equal to half a degree of latitude, and occasion a difference of temperature of nearly twelve degrees of Fahrenheit. Hence it is that the agriculture of the temperate may sometimes be adopted in the torrid zone, and that some of the mountains of Jamaica will produce between their base and summit, almost all the plants of the world. Hence, also, that even in the limited extent of the island of Britain, a given elevation on mountains in Devonshire will be adapted for a different agriculture to the same elevation on the Cheviot, Grampian or Sutherland mountains; and while wheat ripens at six hundred feet above the level of the sea in Cornwall, oats will hardly ripen at that height in the Western isles.



1236. *Elevation exposes plants and animals to the powerful operation of wind*, and in this respect must influence the disposition of the fields, fences, plantations, and buildings of the agriculturist, as well as the plants and animals cultivated. It has some influence also on the density of the air and the supplies of water and vapour, and even in these respects must affect the character of the agriculture. In Switzerland and Norway the upper mountain farms are completely above the mere dense strata of clouds, and their occupiers are often for weeks together without getting a view of the plains or valleys below.

1237. *That soil* must influence the agriculture of a country appears at first sight very obvious; though if climate be favorable, time and art will render the soil fit for any species of culture. Naturally, however, soil has a powerful influence; and the period under ordinary management will be considerable, before strong deep clays on a flat surface, can be rendered equally fit for the turnip or potatoe, with friable loams, or more gravelly or sandy soils.

1238. *The influence of moisture* on the state of lands, is naturally very considerable, and though draining and irrigation can effectually remove excess or supply deficiency, yet fen lands and chalk hills, such as we find in Huntingdonshire, Surrey, and other counties, will ever have a peculiar character of agriculture; the marsh perennial hay grasses will be the characteristic plants of the former, and saintfoin of the latter.

1239. *As the general result* of this outline of the influence of physical circumstances on agriculture, we may form a classification of that of any particular country to whichever of the four universal divisions (1228. to 1231.) it belongs. We submit the following:—

1240. *The agriculture of water-fed lands*, including fens, marshes, and marsh meadows.

1241. *The agriculture of sun-burnt lands*, including chalk, gravel, and sandy hills, where vegetation is annually more or less burned up during two or more of the summer months.

1242. *The agriculture of mountains*, in which the farmery is placed on the farm, as distinguished from those cases in which the mountain lands or a part of them are appended to lands on the plain.

1243. *Common agriculture*, or that of the plains, valleys, and hills of a country in which all the crops and all the animals suitable to the climate may be profitably cultivated and reared.

### CHAP. III.

#### *Agriculture as affected by Civil, Political, and Religious Circumstances.*

1244. *The influence of the state of society and government on agriculture*, must obviously be very considerable, as well as climate and situation; for it will signify little what a country is capable of producing, if the inhabitants are too barbarous to desire, too ignorant to know, or too much oppressed to attain these products. Some of the finest lands in the world, capable of producing wheat, maize, rice, and the grape, are inhabited by savages, who live on game, wild fruits, or native roots; or by half civilized tribes who cultivate maize, and yams, or some other local root. Even in Ireland, where the soil is better than in Britain, and with very moderate culture will produce excellent wheat and other corns, with beef, mutton, and wool, the greater part of the inhabitants from ignorance, oppression, and in part as we have seen (840.) religious

slavery, content themselves with roots and rags, the latter often the cast off refuse of other countries (830).

1245. *The state of civilization and refinement of a people* not only influences agriculture by the nature of the products such a state requires, but also by the means it affords of producing these products. By the superiority of the means of information on every subject; by the existing state of knowledge, for example, in mechanics, chemistry, and physiology, by which the implements and machines are improved, the operations of soils and manures regulated, the influence of water, the atmosphere, and the functions of plants and animals understood. The difference in the means taken to effect the same end in a poor but yet ingenious country, and in one rich and enlightened, is exemplified in China and India, compared with Britain; and between a comparatively poor and intelligent country, and a rich ignorant country, in comparing Scotland and England, at least as far as agriculture is concerned. Wealth and ignorance, as contrasted with poverty and ingenuity, may also be exemplified in comparing the farmer of Hindustan with the English farmer. The latter to stir the soil, employs an unwieldy implement drawn by several oxen or horses; the former uses a small light implement drawn by one ox or buffalo, but effects his object by repeating the operation many times. The Englishman effects it at once, often in spite of the worst means, by main force. The processes of Chinese manufacture are exceedingly curious and ingenious, and form a remarkable contrast to the rapid and scientific processes of Britain. There are many curious practices in France and Germany, the result of poverty and ingenuity. In Brittany the whin is used as horse provender: to bruise the spines one man operates on a simple but ingenious machine (*fig. 216.*), and effects his purpose completely. Here the same thing is done by a couple of iron rollers turned by a horse or by water. But the farmer of Brittany, who would purchase a pair of whin bruising-rollers, must first sell the greater part of his stock and crop.

216

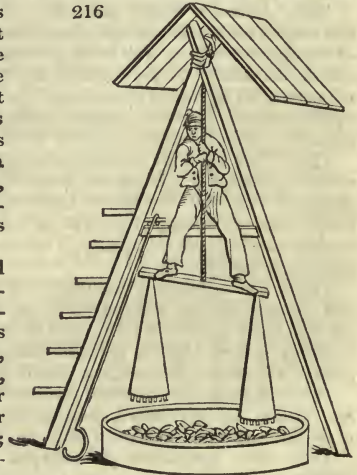

1246. *The political state of a country* will powerfully affect its agriculture. Where security, the greatest object of government, is procured at too high a rate, the taxes will depress the cultivator, and not only consume his profits, but infringe on his capital; where security, either relatively to external circumstances, or internal laws, is incomplete, there the farmer who has capital will be unwilling to risk it; few who have capital will engage in that profession; and if any finds it profitable, the fear of exposing himself to exactions from government or his landlord, will prevent him from making a proper use of his profits either in the way of employment or consumption. Many instances of this state of things are to be found in the foregoing history. Wherever the metayer system, or short leases prevail, whatever may be the nature or practice of the government, these remarks will apply. Security and liberty at a moderate price are essential to the prosperity of agriculture, even more so than to manufactures or commerce.

1247. *Religion* may be thought to have very little influence on agriculture: but in a Catholic or Mahomedan country where the religion enjoins a frequent abstinence from animal food, and long periodical fasts from even the produce of the cow, surely the rearing and feeding of stock for the shambles or the dairy cannot prosper to the same extent as in a country less enslaved by prejudice, or whose religious opinions do not interfere with their cookery. The number of holidays is also a great grievance.

1248. *The natural character of a people* may even have some influence on their agriculture, independently of all the other circumstances mentioned. The essential character of a people is formed by the climate and country in which they live, and their factitious or accidental character by their government and religion for the time being. The latter may alter, but the original or native character remains. Thus the French appear to be the same gay people which they were in the time of Julius Cæsar; and as far as history enables us to judge, the Greeks and Romans have only lost their accidental character. The love of society and social amusements inherent in every class of Frenchmen, will probably long prevent their agriculturists from isolating their farmeries, as in the vale of Arno and the Alpine regions of Europe, and indeed of every mountainous country. French and Italian farmers, in general, live together in villages, sometimes five or six miles distant from their farms: early in the morning the household set out with the cattle and

implements, and their food for the day; they work till near mid-day, and then refresh themselves, and repose under a tree, or in winter under a temporary shed; at night they return, meet their neighbours, make a protracted supper, and amuse themselves in fiddling and dancing, till they have exhausted their superfluous spirits.

1249. *The agriculture of the world in regard to the state of society* may perhaps admit of the following divisions. —

1250. *The agriculture of science*, or modern farming, in which the cultivator is secure in his property or possession, both relatively to the government and landlord under which he lives, as generally in Britain and North America.

1251. *The agriculture of habit*, or feudal culture, in which the cultivator is a metayer, or a tenant at will, or on a short lease, or has covenanted to pursue a certain fixed system of culture.

1252. *Barbarian agriculture*, or that of a semi-barbarous people who cultivate at random, and on land to which they have no defined right of possession, roots or grain without regard to rotation, order, or permanent advantage.

1253. *The economy of savages*, such as hunting, fishing, gathering fruits, or digging up roots.

---

#### CHAP. IV.

##### *Of the Agriculture of Britain.*

1254. To which of these *geographical, physical, and social divisions of agriculture* that of the British isles may be referred, is the next object to be determined, and we submit the following as its classification.

1255. *Geographically* it is the agriculture of draining and manures.

1256. *Physically*, those of water-fed and sun-burnt lands, mountains, and variable plains.

1257. *Socially* considered, it is the agriculture of science.

1258. *The following PARTS of this work*, therefore, are to be considered as treating of a kind of agriculture so characterized; that is, of the agriculture of our own country. Whoever has paid a due attention to what has preceded, can scarcely fail to have formed an idea of the agriculture of every other part of the world, sufficient to enable him to determine that very little in our art is to be learned any where else than among ourselves.

---

## PART II.

### AGRICULTURE CONSIDERED AS A SCIENCE.

1259. *All knowledge is founded on experience*; in the infancy of any art, experience is confined and knowledge limited to a few particulars; but as arts are improved and extended a great number of facts become known, and the generalization of these, or the arrangement of them according to some leading principle, constitutes the theory, science, or law of an art.

1260. *Agriculture, in common with other arts*, may be practised without any knowledge of its theory; that is, established practices may be imitated; but in this case it must ever remain stationary. The mere routine practitioner cannot advance beyond the limits of his own particular experience, and can neither derive instruction from such accidents as are favorable to his object, nor guard against the re-occurrence of such as are unfavorable. He can have no resource for unforeseen events but ordinary expedients; while the man of science resorts to general principles, refers events to their true causes, and adapts his measures to meet every case.

1261. *The object of the art of agriculture* is to increase the quantity and improve the quality of such vegetable and animal productions of the earth as are used by civilized man; and the object of the agriculturist is to do this with the least expenditure of means; or, in other words, with profit. The result of the experience of mankind as to other objects may be conveyed to an enquiring mind in two different ways: he may be instructed in the practical operations of the art, and their theory, or the reasons on which they are founded, laid down and explained to him as he goes along; or he may be first instructed in general principles, and then in the practices which flow from them. The former

mode is the natural or actual mode in which every art is acquired (in so far as acquirement is made) by such as have no recourse to books, and may be compared to the natural mode of acquiring a language without the study of its grammar. The latter mode is by much the most correct and effectual, and is calculated to enable an instructed agriculturist to proceed with the same kind of confidence and satisfaction in his practice that a grammarian does in the use of language.

1262. In adopting what we consider as *the preferable mode of agricultural instruction*, we shall, as its grammar or science, endeavour to convey a general idea of the nature of vegetables, of animals, of minerals, mixed bodies, and the atmosphere, as connected with agriculture; of agricultural implements and other mechanical agents; and of agricultural operations and processes.

1263. *The study of the science of agriculture* may be considered as implying a regular education in the student, who ought to be well acquainted with arithmetic and mensuration, have acquired the art of sketching objects, whether animal, vegetable, or general scenery, of taking off, and laying down geometrical plans; but especially he ought to have studied chemistry, hydraulics, and something of carpentry, smithery, and the other building arts: and as Professor Von Thaer observes, he ought to have some knowledge of all those manufactures to which his art furnishes the raw materials.

## BOOK I.

### OF THE STUDY OF THE VEGETABLE KINGDOM WITH A VIEW TO AGRICULTURE.

1264. *The various objects with which we are surrounded* are either organized, having several constituent parts which united form a whole capable of increase by nourishment; or they are inorganized, and only increased by additions to their external parts. To the first division belong the animal and vegetable kingdom, and their study is founded chiefly on observation; to the second belongs the mineral kingdom, the study of which in masses, or geology and mineralogy, is also founded chiefly on observation; and in regard to composition and elements, on experiment or chemistry.

1265. *Vegetables are distinguished from animals* as not being endowed with sentiment or a consciousness of existence. Their study has employed the attention of mankind from a very early period; and has been carried to a high degree of perfection within the last century; and more especially by the exertions of Linnæus, Jussieu, Mirbel, and some other French philosophers. This study comprehends systematic botany, vegetable anatomy, vegetable chemistry, physiology, pathology, the distribution of vegetables, and vegetable culture. The study of these branches is of the utmost importance to the agriculturist, especially that of vegetable physiology; and though the limits of this work do not permit us to enter into the subject at great length; yet we shall direct his attention to the leading points, and refer him to the best books.

## CHAP. I.

### *Of the Study of Systematic Botany.*

1266. *Glossology*, or the study of the names of the parts of plants, is the first step in this department.

1267. *All the arts and sciences require to express with brevity and perspicuity a crowd of ideas unused in common language*, and unknown to the greater part of men. Whence that multitude of terms, or technical turns, given to ordinary words which the public turn often into ridicule, because they do not feel the use of them, but which all those are obliged to make use of, who apply themselves to any study whatever. Botany having to describe an immense number of beings, and each of these beings having a great variety of organs, requires a great variety of terms. Nearly all botanists are agreed as to these terms, and in order that they may be universally understood and remain unchanged in meaning, they are taken from a dead or fixed language.

1268. *A plant in flower surveyed externally*, may be perceived to be composed of a variety of obvious parts, such as the root, the stem, the branch, the leaf, the flower, the fruit, and perhaps the seed; and other parts less obvious, as buds, prickles, tendrils, hairs, glands, &c. These, with their modifications, and all the relative circumstances which enter into the botanical description of a plant, constitute the subject of glossology, or the study of the language of botany. The reader may consult *Smith's Introduction to Botany*, or almost any recent work on the elements of botanical science.

1269. *Phytography, or the naming and describing of plants*, is the next part of the subject to be considered. Before botany became a regular science, plants were named as individual beings, without regard to any relation which they had to one another. But from the great number of names to be retained on the memory, and the obvious affinities existing among certain individuals or natural families, some method was soon found necessary, and it was then deemed requisite to give such composite names as might recall to mind something of the individuals to which they were applied. Thus we have *Anagalis flore cærulea*, *Mespilus aculeata pyrifolia*, &c. In the end, however, the length of these phrases became inconvenient, and Linnæus,

struck with this inconvenience, proposed that the names of plants should henceforth consist of two words only, the one the generic or family name, and the other the specific or individual name.

1270. *The names of classes and orders* were originally primitive, or without meaning, as the *Grasses* of Tragus, *Poppies* of Bauhin, &c.; and afterwards so compounded as to be long and complex, as the *Polloptostemonopetalæ*, *Eleutheromacrestemes*, &c. of Wachendorf. Linnæus decided, that the names of classes and orders should consist of a single word, and that word not simple or primitive, but expressive of a certain character or characters, found in all the plants which compose it.

1271. *In applying names to plants, three rules are laid down by botanists*: 1st. That the languages chosen should be fixed and universal, as the Greek and Latin. 2d. That these languages should be used according to the general laws of grammar, and compound words always composed from the same language, and not of entire words, &c. 3d. That the first who discovers a being, and enregisters it in the catalogue of nature, has the right of giving it a name; and that that name ought to be received and admitted by naturalists, unless it belong to a being already existing, or transgress the rules of nomenclature. Every one that discovers a new plant may not be able to enregister it according to these laws, and in that case has no right to give it his name; but the botanist who enregisters it, and who is in truth the discoverer, may give it the name of the finder, if he chooses.

1272. *The whole vegetable kingdom is divided into classes, orders, genera, species, and varieties.* A class is distinguished by some character which is common to many plants; an order is distinguished by having some character limited to a few plants belonging to a class; a still more limited coincidence constitutes a genus; and each individual of a genus, which continues unchanged when raised from seed, is called a species. A variety is formed by an accidental deviation from the specific character, and easily returns by seed to the particular species from which it arose.

1273. *For the purposes of recording and communicating botanical knowledge*, plants are described, and this is done either by the use of language alone, or by language and figures, models or dried plants, conjoined. The description of plants may be either abridged or complete. The shortest mode of abridgment is that employed in botanical catalogues, as in those of Donn or of Sweet. The most exact descriptions are deficient without *figures or an herbarium*. Hence the advantage of being able to see plants at pleasure, by forming dried collections of them. The greater part of plants dry with facility between the leaves of books, or other paper, the smoother the better. If there be plenty of paper, they often dry best without shifting; but if the specimens are crowded, they must be taken out frequently, and the paper dried before they are replaced.

1274. *The language of botany* may be acquired by two methods, analogous to those by which common languages are acquired. The first is the natural method, which begins with the great and obvious classes of vegetables, and distinguishes trees, grasses, &c.; next individuals among these, and afterwards their parts or organs. This knowledge is acquired insensibly, as we acquire our native tongue. The second is the artificial method, and begins with the parts of plants, as the leaves, roots, &c. ascending to nomenclature and classification, and is acquired by particular study, aided by books or instructors, as one acquires a dead or foreign language. This method is the fittest for such as wish to attain a thorough knowledge of plants, so as to be able to describe them; the other mode is easier, and the best suited for cultivators, whose object does not go beyond that of understanding their descriptions, and studying their physiology, history, and application. A very good method for a person at a distance from botanists, is to form a collection of dried specimens of all the plants which he wishes to know the names of, and to send them to the curator of the nearest botanic garden, requesting him to write the name below each specimen, and refer to some work easily procured, such as Withering or Gray's *Arrangement of British Plants*, in which is given its description, uses, history, &c. Smith's *Introduction*, and the *Elements* of Decandolle and Sprengel, may be referred to as the best works on phytagraphy and nomenclature.

1275. *Taxonomy, or the classification of plants*, is the last part of the study of technological botany. It is very evident, that, without some arrangement, the mind of man would be unequal to the task of acquiring even an imperfect knowledge of the various objects of nature. Accordingly, in every science, attempts have been made to classify the different objects that it embraces, and these attempts have been founded on various principles. Some have adopted artificial characters; others have endeavoured to detect the natural relations of the beings to be arranged, and thus to ascertain a connection by which the whole may be associated. In the progress of zoology and physiology, the fundamental organs on which to found a systematic arrangement have been finally agreed on. In both, those which are essential, and which discover the greatest variety, form the basis of classification. Animals are found to differ most from each other in the organs of nutrition, and plants in the organs of reproduction.

1276. *Two kinds of methods of arranging vegetables* have been distinguished by botanists, the natural and the artificial. A natural method is that, which, in its distribution, retains all the natural classes; that is, such into which no plants enter that are not connected by numerous relations, or that can be disjoined without doing a manifest violence to nature. An artificial method is that whose classes are not natural, because they collect together several genera of plants which are not connected by numerous relations, although they agree in the characteristic mark or marks, assigned to that particular class or assemblage to which they belong. An artificial method is easier than the natural, as in the latter it is nature, in the former the writer, who prescribes to plants the rules and order to be observed in their distribution. Hence, likewise, as nature is ever uniform, there can be only one natural method; whereas artificial methods may be multiplied almost *ad infinitum*, according to the several different relations under which bodies are viewed.

1277. *The object of the natural method* is to promote our knowledge of the vegetable kingdom by generalizing facts and ideas; the object of the artificial method is to facilitate the knowledge of plants as individual objects. The merits of the former method consist in the perfection with which plants are grouped together in natural families or orders, and these families grouped among themselves; the merits of the latter consist in the perfection with which they are arranged according to certain marks by which their names may be discovered. Plants arranged according to the natural method may be compared to words arranged according to their roots or derivations; arranged according to an artificial method they may be compared to words in a dictionary. The success attending attempts at botanical arrangement, both naturally and artificially, has been singularly striking. Linnæus has given the most beautiful artificial system that has ever been bestowed by genius on mankind; and Jussieu has, with unrivalled ability, exhibited the natural affinities of the vegetable kingdom. For the study of this department we refer to the works of Smith, Decandolle, and Gray, already mentioned.

## CHAP. II.

*Vegetable Anatomy, or the Structure and Organization of Plants.*

1278. *Vegetables may be classed for the study of their anatomy and physiology, according as they are distinguished by a structure or organization more complicated or more simple. The former will constitute what may be denominated perfect plants, and will form a class comprehending the principal mass of the vegetable kingdom. The latter will constitute what may be denominated imperfect plants, and will form a class comprehending all such vegetables as are not included in the foregoing class. We shall first consider their external, and next their internal organization.*

SECT. I. *Of the External Structure of Perfect Plants.*

1279. *The parts of perfect plants may be distributed into conservative and reproductive, as corresponding to their respective functions in the economy of vegetation.*

1280. *The conservative organs are such as, are absolutely necessary to the growth and preservation of the plant, and include the root, trunk, branch, leaf, and frond.*

1281. *The root is that part of the plant by which it attaches itself to the soil in which it grows, or to the substance on which it feeds, and is the principal organ of nutrition.*

1282. *The trunk is that part of the plant which, springing immediately from the root, ascends in a vertical position above the surface of the soil, and constitutes the principal bulk of the individual.*

1283. *The branches are the divisions of the trunk, originating generally in the upper extremity, but often also along the sides.*

1284. *The leaf, which is a temporary part of the plant, is a thin and flat substance of a green color, issuing generally from numerous points towards the extremities of the branches, but sometimes also immediately from the stem or root, and distinguishable by the sight or touch into an upper and under surface, a base and apex, with a midrib and lateral nerves.*

1285. *The frond, which is to be regarded as a compound of several of the parts already described, consists of an union or incorporation of the leaf, leaf-stalk, and branch or stem, forming as it were but one organ, of which the constituent parts do not separate spontaneously from one another by means of the fracture of any natural joint, as in the case of plants in general, but adhere together even in their decay. It is found in palms and ferns.*

1286. *The conservative appendages are such accessory or supernumerary parts as are found to accompany the conservative organs occasionally, but not invariably. They are permanent in whatever species they are found to exist; some being peculiar to one species, and some to another. But they are never found to be all united in the same species, and are not necessarily included in the general idea of the plant. They are denominated gems, glands, tendrils, stipulæ, armature, pubescence, and anomalies.*

1287. *Gems or bulbs are organized substances issuing from the surface of the plant, and containing the rudiments of new and additional parts which they protrude; or the rudiments of new individuals which they constitute by detaching themselves ultimately from the parent plant, and fixing themselves in the soil.*

1288. *Glands are small and minute substances of various different forms, found chiefly on the surface of the leaf and petiole, but often also on the other parts of the plant, and supposed to be organs of secretion.*

1289. *The tendril is a thread-shaped and generally spiral process issuing from the stem, branch, or petiole, and sometimes even from the expansion of the leaf itself, being an organ by which plants of weak and climbing stems attach themselves to other plants, or other substances for support; for which purpose it seems to be well fitted by nature, the tendril being much stronger than a branch of the same size.*

1290. *The stipulæ are small and foliaceous appendages accompanying the real leaves, and assuming the appearance of leaves in miniature.*

1291. *Ramenta are thin, oblong, and strap-shaped appendages of a brownish color, issuing from the surface of the plant, and somewhat resembling the stipulæ, but not necessarily accompanying the leaves.*

1292. *The armature consists of such accessory and auxiliary parts as seem to have been intended by nature to defend the plant against the attacks of animals.*

1293. *The pubescence is a general term, including under it all sorts of vegetable down or hairiness, with which the surface of the plant may be covered, finer or less formidable than the armature.*

1294. *Anomalies. There are several other appendages proper to conservative organs, which are so totally different from all the foregoing, that they cannot be classed with any of them; and so very circumscribed in their occurrence, that they do not yet seem to have been designated by any peculiar appellation. The first anomaly, as affects the conservative appendages, occurs in *dionæa muscipula* or *Venus's fly-trap* (fig. 217 a). A second is that which occurs in *sarracenia purpurea* or purple side-saddle-flower (b). A third, which is still more singular, occurs in *nepenthes distillatoria* (c). The last anomaly*



is that of a small globular and membranaceous bag, attached as an appendage to the roots and leaves of some of the aquatics. It is confined only to a few genera, but is to be seen in great abundance on the roots or leaves of the several species of utricularia inhabiting the ponds and ditches of this country; and on the leaves of *aldrovanda vesiculosa*, an inhabitant of the marshes of Italy. In *utricularia vulgaris* this appendage is pear-shaped, compressed with an open border at the small end, furnished with several slender fibres originating in the margin, and containing a transparent and watery fluid, and a small bubble of air, by means of which it seems to acquire a buoyancy that suspends it in the water.

1295. *The reproductive organs* are such parts of the plant as are essential to its propagation, whose object is the reproduction of the species, terminating the old individual, and beginning the new. It includes the flower, with its immediate accompaniments or peculiarities, the flower-stalk, receptacle, and inflorescence, together with the ovary or fruit.

1296. *The flower*, like the leaf, is a temporary part of the plant, issuing generally from the extremity of the branches, but sometimes also from the root, stem, and even leaf, being the apparatus destined by nature for the production of the fruit, and being also distinguishable, for the most part, by the brilliancy of its coloring or the sweetness of its smell.

1297. *The flower-stalk* is a partial trunk or stem, supporting one or more flowers, if the flowers are not sessile, and issuing from the root, stem, branch, or petiole, and sometimes even from the leaf.

1298. *The receptacle* is the seat of the flower, and point of union between the different parts of the flower, or between the flower and the plant, whether immediate and sessile, or mediate and supported upon a flower-stalk.

1299. *The inflorescence*, mode of flowering, is the peculiar mode of aggregation in which flowers are arranged or distributed upon the plant.

1300. *The fruit* is the ripened ovary, or seed-vessel which succeeds the flower. In popular language the term is confined chiefly to such fruits as are esculent, as the apple, the peach, and the cherry; but with the botanist the matured ovary of every flower, with the parts contained, constitutes the fruit.

1301. *Appendages*. The reproductive organs, like the conservative organs, are often found to be furnished with various additional and supernumerary parts, not at all essential to their constitution, because not always present, and hence denominated appendages. Many of them are precisely of the same character with that of the conservative appendages, except that they are of a finer and more delicate texture. Such are the glands, down, pubescence, hairs, thorns or prickles, with one or other of which the parts of the fructification are occasionally furnished. But others are altogether peculiar to the reproductive organs, and are to be regarded as constituting, in the strict acceptation of the term, true reproductive appendages. Some of them are found to be proper to the flower, as the involucre, spathe, bracte, &c., and others to the fruit as the persisting calyx, exemplified in the pomegranate.

## SECT. II. *Of the External Structure of Imperfect Plants.*

1302. *Plants apparently defective* in one or other of the more conspicuous parts or organs, whether conservative or reproductive, are denominated imperfect. The most generally adopted division of imperfect plants is that by which they are distributed into filices, equisetaceæ, lycopodinæ, musci, hepaticæ, algæ, lichenæ, and fungi.

1303. *The filices, equisetaceæ, and lycopodinæ*, are for the most part herbaceous, and die down to the ground in the winter, but they are furnished with a perennial root, from which there annually issues a frond bearing the fructification. The favorite habitations of many of them are heaths and uncultivated grounds, where they are found intermixed with furze and brambles; but the habitations of such as are the most luxuriant in their growth are moist and fertile spots, in shady and retired situations, as on mossy dripping rocks, or by fountains and rills of water. Some of them will thrive even on the dry and barren rock, or in the chinks and fissures of walls; and others only in wet and marshy situations where they are half immersed in water.

1304. *The mosses* (fig. 218.) are a tribe of imperfect plants of a small and diminutive size, consisting often



merely of a root, surmounted with a tuft of minute leaves, from the centre of which the fructification springs, but furnished for the most part with a stem and branches, on which the leaves are closely imbricated, and the fructification terminal or lateral. They are perennials and herbaceous, approaching to shrubby; or annuals, though rarely so, and wholly herbaceous, the perennials being also evergreens.

1305. *The hepaticæ* are a tribe of small and herbaceous plants resembling the mosses, but chiefly constituting fronds, and producing their fruit in a capsule that splits into longitudinal valves. In their habita-

tions, they affect for the most part the same sort of situations as the mosses, being found chiefly in wet and shady spots, by the sides of springs and ditches, or on the shelving brinks of rivulets, or on the trunks of trees. Like the mosses, they thrive best also in cold and damp weather, and recover their verdure though dried, if moistened again with water.

1306. *The algæ, or sea-weeds*, include not merely marine and many other immersed plants, but also a great variety of plants that are not even aquatic. All the algæ, agree in the common character of having their herbage frondose, or but rarely admitting of the distinction of root, stem, and leaf.

1307. *The utility of the algæ* is obviously very considerable, whether we regard them as furnishing an article of animal food, or as applicable to medicine and the arts. The fucus saccharinus (fig. 219 a.), palmatus (b), and edulis (c), and several other fuci, are eaten and much relished by many people, whether raw or dressed, and it is likely that some of them are fed upon by various species of fish. The fucus lichenoides (Turner, c. 118.) is now believed to be the chief material of the edible nests of the East India swallows, which are so much esteemed for soups, that they sell in China for their weight in gold. When disengaged from their place of growth and thrown upon the sea-shore, the European algæ are often collected by the farmer and used as manure. They are often also employed in the preparation of dyes, as well as in the lucrative manufacture of kelp, a commodity of the most indispensable utility in the important arts of making soap and glass.



1308. *The utility of the lichensæ* is also worthy of notice. The lichen rangiferinus forms the principal nourishment of the reindeer during the cold months of winter, when all other herbage fails. The lichen islandicus is eaten by the Icelanders instead of bread, or used in the preparation of broths, and, like the lichen pulmonarius, has been lately found to be beneficial in consumptive affections. Many of them are also employed in the preparation of some of our finest dyes, or pigments; and it is from the lichen parellus that the chemical analyst obtains his litmus. The lichens and the mosses seem instituted by nature to provide for the universal diffusion of vegetable life over the whole surface of the terrestrial globe. The powdery and tuberculous lichens attach themselves even to the bare and solid rock. Having reached the maturity of their species, they die and are converted into a fine earth, which forms a soil for the leathery lichens. These again decay and moulder into dust in their turn; and the depth of soil, which is thus augmented, is now capable of nourishing and supporting other tribes of vegetables. The seeds of the mosses lodge in it, and spring up into plants, augmenting also by their decay the quantity of soil, and preparing it for the support of plants of a more luxuriant growth, so that in the revolution of ages even the surface of the barren rock is covered with a soil capable of supporting the loftiest trees.

1309. *The fungi are a tribe of plants whose herbage is a frond of a fleshy or pulpy texture*, quick in its growth, and fugacious in its duration, and bearing seeds or gems in an appropriate and exposed membrane, or containing them interspersed throughout its mass. They are also a tribe of plants that may be regarded as the lowest in the vegetable scale, exhibiting a considerable resemblance to the tribe of zoophytes, and thus forming the connecting link between the vegetable and animal kingdoms. The habitations they affect are very various, many of them vegetating on the surface of the earth (fig. 220 a), and some of them even buried under it; others on stumps and trunks of rotten trees (b); others on decayed fruit; others on damp and wet walls; and others on animal ordure.



1310. *Uses of the fungi.* The powder of the lycoperdons is said to be an excellent optic; and is remarkable also for its property of strongly repelling moisture. If a basin filled with water, and a little of the powder strewed upon the surface so as to cover it only, the hand may be plunged into it and thrust down to the bottom without being wetted with a single drop of water. Several of the boleti, when dried, afford a very useful tinder; and several of the agarics and tubers are used as articles of food, or as ingredients in the preparation of seasoning. The truffle (fig. 221.) is much



esteemed for the rich and delicate flavor which it imparts to soups and sauces; and the mushroom (*fig. 222.*) and morcel (*fig. 223.*) for their esculent property, and utility in the preparation of ketchup.

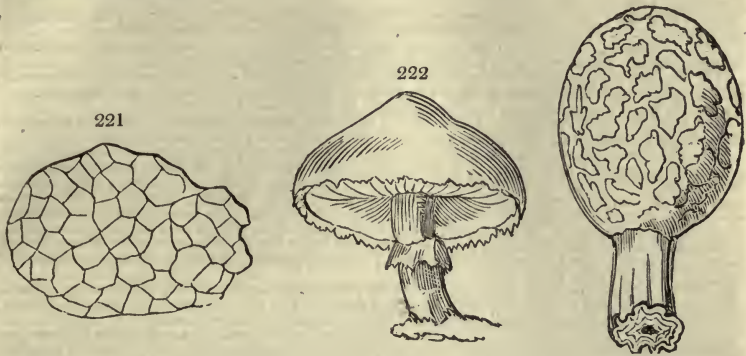

SECT. III. *Of the Internal Structure of Plants.*

1311. *The organs of plants discoverable by external examination, are themselves reducible in component organs, which are again resolvable into constituent and primary organs. These are called the decomposite, the composite, and the elementary.*

SUBSECT. I. *Decomposite Organs.*

1312. *The decomposite organs constitute the vegetable individual, and are distinguishable on external examination; to the dissection of which we will now proceed, in the order of the seed, pericarp, flower, leaf, gem, and caudex, or branch, stem, and root, with their decomposite appendages.*

1313. *The seed.* The mass of the seed consists of two principal parts, distinguishable without much difficulty; namely, the integuments and nucleus, or embryo and its envelopes.

1314. *The integuments proper to the seed are two in number, an exterior integument and an interior integument.*

1315. *The exterior integument, or testa, is the original cuticle of the nucleus, not detachable in the early stages of its growth, but detachable at the period of the maturity of the fruit, when it is generally of a membranaceous or leathery texture; though sometimes soft and fleshy, and sometimes crustaceous and bony. It may be very easily distinguished in the transverse or longitudinal section of the garden-bean or any other large seed.*

1316. *The interior integument, or sub-testa, lines the exterior integument, or testa, and immediately envelops the nucleus. Like the testa, to which indeed it adheres, it may be easily distinguished in the garden-bean (*fig. 224.*), or in a ripe walnut; in which last it is a fine transparent and net-like membrane.*

1317. *The nucleus is that part of the seed which is contained within the proper integuments, consisting of the albumen with the vitellus, when present, and embryo.*

1318. *The albumen is an organ resembling in its consistence the white of an egg, and forming, in most cases, the exterior portion of the nucleus, but always separable from the interior or remaining portion.*

1319. *The vitellus is an organ of a fleshy but firm contecture, situated, when present, between the albumen and embryo; to the former of which it is attached only by adhesion, but to the latter by incorporation of substance, so as to be inseparable from it, except by force.*

1320. *The embryo (a), which is the last and most essential part of the seed and final object of the fructification, as being the germ of the future plant, is a small and often very minute organ, enclosed within the albumen and occupying the centre of the seed.*

1321. *The cotyledon or seed-lobe (b), is that portion of the embryo that encloses and protects the plantlet, and springs up during the process of germination into what is usually denominated the seminal leaf, if the lobe is solitary; or seminal leaves, if there are more lobes than one. In the former case the seed is said to be monocotyledonous; in the latter case, it is said to be dicotyledonous. Dicotyledonous seeds, which constitute by far the majority of seeds, are well exemplified in the garden-bean. As there are some seeds whose cotyledon consists of one lobe only, falling short of the general number, so there are also a few whose cotyledon is divisible into several lobes, exceeding the general number. They have been denominated polycotyledonous seeds, and are exemplified in the case of *lepidium sativum* or common garden-cress, in which the lobes are six in number; as in that also of the different species of the genus *pinus*, in which they vary from three to twelve.*

1322. *The plantlet, or future plant in miniature, is the interior and essential portion of the embryo, and seat of vegetable life. In some seeds it is so minute as to be scarcely perceptible; while in others it is so large as to be divisible into distinct parts, as in the garden-bean.*

1323. *The pericarp, which in different species of fruit assumes so many varieties of contecture, acquires its several aspects, not so much from a diversity of substance as of modification.*

1324. *The valves of the capsule, but particularly the partitions by which it is divided into cells, are composed of a thin and skinny membrane, or of an epidermis covering a pulp more or less indurated, and in-*

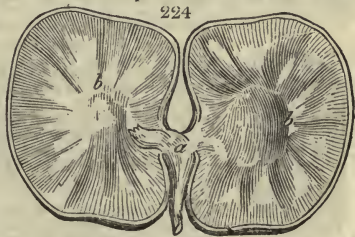

terspersion with longitudinal fibres. The capsule of the mosses is composed of a double and net-like membrane, enclosed within a fine epidermis.

1325. *The pome* is composed of a fine but double epidermis, or, according to Knight, of two skins, enclosing a soft and fleshy pulp, with bundles of longitudinal fibres passing through it, contiguous to, and in the direction of, its longitudinal axis.

1326. *The valves of the legume* are composed of an epidermis enclosing a firm but fleshy pulp, lined for the most part with a skinny membrane, and of bundles of longitudinal fibres, forming the seam.

1327. *The nutshell*, whether hard or bony, or flexible and leathery, is composed of a pulp more or less highly indurated, interspersed with longitudinal fibres, and covered with an epidermis.

1328. *The drupe* is composed of an epidermis enclosing a fleshy pulp, which is sometimes so interwoven with a multiplicity of longitudinal fibres as to seem to consist wholly of threads, as in the cocoa-nut.

1329. *The berry* is composed of a very fine epidermis enclosing a soft and juicy pulp.

1330. *The scales of the strobile* are composed of a tough and leathery epidermis, enclosing a spongy but often highly indurated pulp interspersed with longitudinal fibres that pervade also the axis.

1331. *The flower-stalk*, or peduncle supporting the flower, which is a prolongation of the stem or branch, or rather a partial stem attached to it, if carefully dissected with the assistance of a good glass, will be found to consist of the following several parts:—1st, An epidermis, or external envelope; 2dly, A parenchyma, or soft and pulpy mass; 3dly, Bundles of longitudinal threads or fibres, originating in the stem or branch, and passing throughout the whole extent of the parenchyma. The several organs of the flower are merely prolongations of the component parts of the flower-stalk, though each organ does not always contain the whole of such component parts, or at least not under the same modifications. The epidermis, however, and parenchyma are common to them all; but the longitudinal threads or fibres are seldom, if ever, to be found, except in the calyx or corolla.

1332. *The leaf-stalk*, or petiole supporting the leaf, which is a prolongation of the branch or stem, or rather a partial stem attached to it, exhibits upon dissection the same sort of structure as the peduncle, namely, an epidermis, a pulp or parenchyma, and bundles of longitudinal threads or fibres.

1333. *Gems*. There exists among the different tribes of vegetables four distinct species of gems, two peculiar to perfect plants, the bud and bulb, and two peculiar to imperfect plants, the propago and gongylus; the latter being denominated simple gems, because furnished with a single envelope only; and the former being denominated compound gems, because furnished with more than a single envelope.

1334. *Buds* are composed externally of a number of spoon-shaped scales overlapping one another, and converging towards a point in the apex, and often cemented together by means of a glutinous or mucilaginous substance exuding from their surface. If these scales are stripped off and dissected under the microscope, they will be found to consist, like the leaves or divisions of the calyx, of an epidermis enclosing a pulp interspersed with a network of fibres, but unaccompanied with longitudinal threads. If the scales of a leaf-bud are taken and stripped off, and the remaining part carefully opened up, it will be found to consist of the rudiments of a young branch terminated by a bunch of incipient leaves imbedded in a white and cottony down, being minute but complete in all their parts and proportions, and folded or rolled up in the bud in a peculiar and determinate manner.

1335. *Bulbs*, which are either radical or caulinary, exhibit in their external structure, or in a part of their internal structure that is easily detected, several distinct varieties, some being solid, some coated, and some scaly; but all protruding in the process of vegetation the stem, leaf, and flower, peculiar to their species.

1336. *The propago*, which is a simple gem, peculiar to some genera of imperfect plants, and exemplified by Gertner in the lichens, consists of a small and pulpy mass forming a granule of no regular shape, sometimes naked, and sometimes covered with an envelope, which is a fine epidermis.

1337. *The gongylus*, which is also a simple gem peculiar to some genera of imperfect plants, and exemplified by Gertner in the fuci, consists of a slightly indurated pulp moulded into a small and globular granule of a firm and solid contexture, and invested with an epidermis.

1338. *The caudex* includes the whole mass or body both of the trunk and root; its internal structure, like its external aspect or habit, is materially different in different tribes of plants.

1339. *The first general mode of the internal structure of the caudex* is that in which an epidermis encloses merely a *homogeneous mass* of pulp or slender fibre. This is the simplest mode of internal structure existing among vegetables; it is exemplified in the lower orders of imperfect plants, particularly the algae and fungi.

1340. *The second general mode of internal structure of the caudex* is that in which an epidermis encloses two or more substances, or assemblages of substances, totally *heterogeneous* in their character. A very common variety of this mode is that in which an epidermis or bark encloses a *soft and pulpy mass*, interspersed with a number of longitudinal nerves or fibres, or bundles of fibres, extending from the base to the apex, and disposed in a peculiarity of manner characteristic of a tribe or genus. This mode prevails chiefly in herbaceous and annual or biennial plants. (fig. 225.) A second variety of this mode is that in which a strong and often thick bark encloses a circular layer of longitudinal fibres, or several such circular and concentric layers, interwoven with thin transverse and divergent layers of pulp, so as to form a *firm and compact cylinder*, in the centre of which is lodged a pulp or pith. This mode is best exemplified in trees and shrubs (fig. 226.), though it is also applicable to many plants whose texture is chiefly or almost wholly herbaceous, forming as it were the connecting link between such plants as are purely herbaceous on the one hand, and such as are purely woody on the other. In the latter case the wood is perfect; in the former case it is imperfect. The wood being imperfect in the root of the beet, the common bramble, and burdock; and perfect in the oak or alder.

226



225

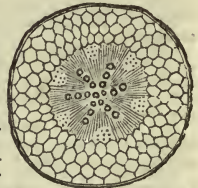

1341. *The appendages* of the plant, whether conservative or reproductive, exhibit nothing in their internal structure that is at all essentially different from that of the organs that have been already described.

## SUBJECT. 2. Composite Organs.

1342. *The composite organs* are the epidermis, pulp, pith, cortical layers, ligneous layers, and vegetable fibre, which may be further analysed, as being still compound, with a view to reach the ultimate and elementary organs of the vegetable subject.

1343. *Structure of the vegetable epidermis*. The epidermis of the vegetable, which, from its resemblance to that of the animal, has been designated by the same name, is the external envelope or integument of the plant, extending over the whole surface, and covering the root, stem, branches, leaves, flower, and fruit, with their appendages; the summit of the pistil only excepted. But although it is extended over the whole surface of the plant, it is not of equal consistence throughout. In the root and trunk it is a tough and leathery membrane, or it is a crust of considerable thickness, forming a notable portion of the bark, and assuming some peculiar shade of color; while in the leaves, flowers, and tender shoots, it is a fine, colorless, and transparent film, when detached; and when adherent, it is always tinged with some peculiar shade, which it borrows from the parts immediately beneath it.

1344. *The pulp* is a soft and juicy substance, constituting the principal mass of succulent plants, and a notable proportion of many parts even of woody plants. It constitutes the principal mass of many of the fungi and fuci, and of herbaceous plants in general. Mirbel compares it to clusters of small and

hexagonal cells or bladders, containing for the most part a colored juice, and formed apparently of the foldings and doublings of a fine and delicate membrane, in which no traces of organization are to be distinguished.

1345. *The pith* is a soft and spongy, but often succulent substance, occupying the centre of the root, stem, and branches, and extending in the direction of their longitudinal axis, in which it is enclosed as in a tube. The structure of the pith is precisely similar to that of the pulp, being composed of an assemblage of hexagonal cells containing a watery and colorless juice, or of cellular tissues and a parenchyma.

1346. *The cortical layers*, or interior and concentric layers, constituting the mass of the bark, are situated immediately under the cellular integument, where such integument exists, and where not, immediately under the epidermis; or they are themselves external. They are distinguishable chiefly in the bark of woody plants, but particularly in that of the lime-tree. They are composed of two elementary parts—bundles of longitudinal fibres constituting a network (fig. 227.), and a mass of pulp more or less indurated, filling up the meshes. The innermost of the layers is denominated the liber, and was used by the ancients to write on before the invention of paper. It is the finest and most delicate of them all, and often most beautifully reticulated (fig. 228 a), and varied by bundles of longitudinal fibre (b). But the liber of *daphne lagetto* is remarkable beyond that of all other plants for the beauty and delicacy of its network, which is not inferior to that of the finest lace, and at the same time so very soft and flexible that in countries of which the tree is a native the lace of the liber is often made to supply the place of a neckcloth. If the cortical layers are injured or destroyed by accident, the part destroyed is again regenerated, and the wound healed up without a scar; but if the wound penetrates beyond the liber, the part destroyed is no longer regenerated. Or if a tree is bent so as to break part of the cortical fibres, and then propped up in its former position, the fractured fibres will again unite. Or if a portion of the stem is entirely decorticated and covered with a piece of bark, even from another tree, the two different barks will unite. Hence the practicability of ascertaining how far the liber extends. And hence also the origin of grafting, which is always effected by a union of the liber of the graft and stock.

1347. *The ligneous layers*, or layers constituting the wood, occupy the intermediate portion of the stem between the bark and pith; and are distinguishable into two different sorts,—concentric layers and divergent layers. (Fig. 227.)

1348. *The concentric layers*, which constitute by far the greater part of the mass of the wood, are sufficiently conspicuous for the purpose of exemplification on the surface of a horizontal section of most trunks or branches, as on that of the oak and elm. But though they are generally described as being concentric, they are not always strictly so. For they are often found to extend more on the one side of the axis of the stem or branch, than on the other. Some authors say the excess is on the north side, but others say it is on the south side. The former account for it by telling us it is because the north side is sheltered from the sun; and the latter by telling us it is because the south side is sheltered from the cold; and thus from the operation of contrary causes alleging the same effect, which has been also thought to be sufficiently striking and uniform to serve as a sort of compass, by which the bewildered traveller might safely steer his course, even in the recesses of the most extensive forest. But Du Hamel has exposed the futility of this notion, by showing that the excess is sometimes on the one side of the axis, and sometimes on the other, according to the accidental situation of the great roots and branches; a thick root or branch producing a proportionally thick layer of wood on the side of the stem from which it issues. The layers are indeed sometimes more in number on the one side than on the other, as well as thicker. But this is the exception, and not the rule. They are thickest, however, on the side on which they are fewest, though not of the same thickness throughout. Du Hamel, after counting twenty layers on the one side of the transverse section of the trunk of an oak, found only fourteen on the other. But the fourteenth exceeded the twenty in thickness by one fourth part. But the layers thus discoverable on the horizontal section of the trunk are not all of an equal consistency throughout, there being an evident diminution in their degree of solidity from the centre, where they are hardest, to the circumference, where they are softest. The outermost layer, which is the softest of all, is denominated the albumen, perhaps from its being of a brighter white than any of the other layers, either of wood or bark; from which character, as well as from its softer texture, it is also easily distinguished. It does not acquire its utmost degree of solidity till after a number of years; but if a tree is barked a year before it is cut down, then the albumen is converted into wood in the course of that year.

1349. *The divergent layers* which intersect the concentric layers in a transverse direction, constitute also a considerable proportion of the wood, as may be seen in a horizontal section of the fir or birch, or of almost any woody plant, on the surface of which they present an appearance like that of the radii of a circle.

1350. *The structure of the concentric layers* will be found to consist of several smaller and component layers, which are themselves composed of layers smaller still, till at last they are incapable of farther division. The concentric layers are composed of longitudinal fibres, generally forming a network; and the divergent layers, of parallel threads or fibres of cellular tissue, extending in a transverse direction, and filling up the interstices of the network.

1351. *The structure of the stem in plants that are purely herbaceous*, and in the herbaceous parts of woody plants, is distinguished by a number of notable and often insulated fibres passing longitudinally throughout its whole extent, as in the stipe of *apsidium filix* mass, or leaf-stalk of the alder. These fibres, when viewed superficially, appear to be merely individuals, but when inspected minutely, and under the microscope, they prove to be groups or bundles of fibres smaller and minuter still, firmly cemented together, and forming in the aggregate a strong and elastic thread, but capable of being split into a number of component fibres, till at last you can divide them no longer. If the fibres of the bark are separated by the destruction of a part, the part is again regenerated, and the fibres are again united, without leaving behind them any traces of a wound. But if the fibres of the wood are separated by the destruction of a part, the part is never regenerated, and the fibres are never united.

### SUBSECT. 3. Elementary or Vascular Organs.

1352. *Fibre, cellular tissue with or without parenchyma, and reticulated membrane*, are the ultimate and elementary organs of which the whole mass of the plant is composed. If it is asked of what the elementary organs are themselves composed, the reply is, they are composed, as appears from the same analysis, of a fine, colorless, and transparent membrane, in which the eye, aided by the assistance even of the best glasses, can discover no traces whatever of organisation; which membrane we must also regard as constituting the ultimate and fundamental fabric of the elementary organs themselves, and, by consequence, of the whole of the vegetable body. It has been asked by some phytologists

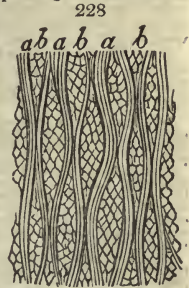
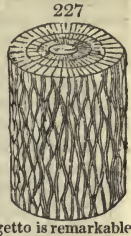

whether or not plants are furnished with vessels analogous to the blood-vessels of the animal system. But if it is admitted that plants contain fluids in motion, which cannot possibly be denied, it will follow, as an unavoidable consequence, that they are furnished with vessels conducting or containing such fluids. If the stem of a plant of marigold is divided by means of a transverse section, the divided extremities of the longitudinal fibres, arranged in a circular row immediately within the bark, will be distinctly perceived, and their tubular structure demonstrated by means of the orifices which they present, particularly when the stem has begun to wither. Regarding it, therefore, as certain that plants are furnished with longitudinal tubes, as well as with cells or utricles for the purpose of conveying or containing their alimentary juices, we proceed to the specific illustration of both, together with their peculiarities and appendages.

1353. *The utricles* are the fine and membranous vessels constituting the cellular tissue of the pith and pulp already described, whether of the plant, flower, or fruit. Individually they resemble oblong bladders inflated in the middle, as in the case of some plants; or circular or hexagonal cells, as in the case of others. Collectively they have been compared to an assemblage of threads of contiguous bladders, or vesicles, or to the bubbles that are found on the surface of liquor in a state of fermentation.

1354. *The tubes* are the vessels formed by the cavities of the longitudinal fibres, whether as occurring in the stem of herbaceous plants, or in the foot-stalk of the leaf and flower, or in the composition of the cortical and ligneous layers, or by longitudinal openings pervading the pulp itself, as in the case of the vine.

1355. *The large tubes* are tubes distinguishable by the superior width of the diameter which they present on the horizontal section of the several parts of the plant.

1356. *Simple tubes* (fig. 229.) are the largest of all the large tubes, and are formed of a thin and entire membrane, without any perceptible disruption of continuity, and are found chiefly in the bark, though not confined to it, as they are to be met with also in the album and matured wood, as well as in the fibres of herbaceous plants.

1357. *Porous tubes* resemble the simple tubes in their general aspect; but differ from them in being pierced with small holes or pores, which are often distributed in regular and parallel rows. They are found in most abundance in woody plants, and particularly in wood that is firm and compact, like that of the oak; but they do not, like the simple tubes, seem destined to contain any oily or resinous juice.

1358. *Spiral tubes* are fine, transparent, and thread-like substances, occasionally interspersed with the other tubes of the plant, but distinguished from them by being

229



twisted from right to left, or from left to right, in the form of a cork screw. They occur in most abundance in herbaceous plants, particularly in aquatics.

1359. *False spiral tubes* are tubes apparently spiral on a slight inspection, but which, upon minute examination, are found to derive their appearance merely from their being cut transversely by parallel fissures.

1360. *Mixed tubes* are tubes combining in one individual two or more of the foregoing varieties. Mirbel exemplifies them in the case of the *batomus umbellatus*, in which the porous tubes, spiral tubes, and false spiral tubes, are often to be met with united in one.

1361. *The small tubes* are tubes composed of a succession of elongated cells united, like those of the cellular tissue. Individually they may be compared to the stem of the grasses, which is formed of several internodia, separated by transverse diaphragms; and collectively to a united assemblage of parallel and collateral reeds.

1362. *Pores* are small and minute openings of various shapes and dimensions, that seem to be destined to the absorption, transmission, or exaltation of fluids. They are distinguishable into perceptible pores and imperceptible pores.

1363. *Gaps*, according to Mirbel, are empty, but often regular and symmetrical spaces formed in the interior of the plant by means of a partial disruption of the membrane constituting the tubes or utricles. In the leaves of herbaceous plants the gaps are often interrupted by transverse diaphragms formed of a portion of the cellular tissue which still remains entire, as may be seen in the transparent structure of the leaves of typha and many other plants. Transverse gaps are said to be observable also in the bark of some plants, though very rarely.

1364. *There are various appendages* connected with the elementary organs, such as internal glands, internal pubescence, &c. : the latter occurs in dissecting the leaf or flower-stalk of *nymphaea lutea*.

### CHAP. III.

#### *Vegetable Chemistry, or Primary Principles of Plants.*

1365. *As plants are not merely organized beings, but beings endowed with a species of life*, absorbing nourishment from the soil in which they grow, and assimilating it to their own substance by means of the functions and operations of their different organs, it is plain that no progress can be made in the explication of the phenomena of vegetable life, and no distinct conception formed of the rationale of vegetation, without some specific knowledge of the primary principles of vegetables, and of their mutual action upon one another. The latter requisite presupposes a competent acquaintance with the elements of chemistry; and the former points out the necessity of a strict and scrupulous analysis of the several compound ingredients constituting the fabric of the plant, or contained within it. If the object of the experimenter is merely that of extracting such compound ingredients as may be known to exist in the plant, the necessary apparatus is simple, and the process easy. But if it is that of ascertaining the primary and radical principles of which the compound ingredients are themselves composed, the apparatus is then complicated, and the process extremely difficult, requiring much time and labor, and much previous practice in analytical research. But whatever may be the object of analysis, or particular view of the experimenter, the processes which he employs are either mechanical or chemical.

1366. *The mechanical processes* are such as are affected by the agency of mechanical powers, and are often indeed the operation of natural causes; hence the origin of gums and other spontaneous exudations. But the substances thus obtained do not always flow sufficiently fast to satisfy the wants or necessities of man. And men have consequently contrived to accelerate the operations of nature by means of artificial aid in the application of the wimble or axe, widening the passages which the extravasated fluid has forced, or opening up new ones. But it more frequently happens that the process employed is wholly

artificial, and altogether effected without the operation of natural causes. When the juices are enclosed in vesicles lodged in parts that are isolated, or may easily be isolated, the vesicles may be opened by means of rasps or graters, and the juices expressed by the hand, or by some other fit instrument. Thus the volatile oil may be obtained that is lodged in the rind of the lemon. When the substance to be extracted lies more deeply concealed in the plant, or in parts which cannot be easily detached from the rest, it may then become necessary to pound or bruise the whole, or a great part of the plant, and to subject it, thus modified, to the action of the press. Thus seeds are sometimes treated to express their essential oils. And if by the action of bruising or pressing heterogeneous ingredients have been mixed together, they may generally be separated with considerable accuracy by means of decantation, when the substances held in suspension have been precipitated. Thus the acid of lemons, oranges, gooseberries, and other fruits, may be obtained in considerable purity, when the mucilage that was mixed with them has subsided.

1367. *The chemical processes* are such as are affected by the agency of chemical powers, and may be reduced to the following: distillation, combustion, the action of water, the action of acids and alkalies, the action of oils and alcohols, and lastly fermentation. They are much more intricate in their nature than the mechanical processes, as well as more difficult in their application.

1368. *Of the products of vegetable analysis*, as obtained by the foregoing processes, some consist of several heterogeneous substances, and are consequently *compound*, as being capable of further decomposition; and some consist of one individual substance only, and are consequently *simple*, as being incapable of further decomposition.

### SECT. I. Compound Products.

1369. *The compound products of analysis* are very numerous in themselves, and much diversified in their qualities. They are gum, sugar, starch, gluten, albumen, fibrina, extract, tannin, coloring matter, bitter principle, narcotic principle, acids, oils, wax, resins, gum resins, balsams, camphor, caoutchouc, cork, woody fibre, sap, proper juice, charcoal, ashes, alkalies, earths, metallic oxides.

1370. *Gum* is an exudation that issues spontaneously from the surface of a variety of plants in the state of a clear, viscid, and tasteless fluid, that gradually hardens upon being exposed to the action of the atmosphere, and condenses into a solid mass. It issues copiously from many fruit-trees, but especially from such as produce stone-fruit, as the plum and cherry-tree. From plants or parts of plants containing it, but not discharging it by spontaneous exudation, it may be obtained by the process of maceration in water.

1371. *The uses of gum* are considerable. In all its varieties it is capable of being used as an article of food, and is highly nutritive, though not very palatable. It is also employed in the arts, particularly in calico-printing, in which the printer makes choice of it to give consistency to his colors, and to prevent them from spreading. The botanist often uses it to fix his specimens upon paper, for which purpose it is very well adapted. It forms likewise an ingredient in ink; and in medicine it forms the basis of many mixtures, in which its influence is sedative and emollient.

1372. *Sugar* is the produce of the *saccharum officinarum*. The canes or stems of the plant, when ripe, are bruised between the rollers of a mill, and the expressed juice is collected and put into large boilers, in which it is mixed with a small quantity of quicklime, or strong ley of ashes, to neutralise its acid, and is then made to boil. The scum which gathers on the top during the process of boiling is carefully cleared away; and when the juice has been boiled down to the consistence of a syrup, it is drawn off and allowed to cool in vessels which are placed above a cistern, and perforated with small holes, through which the impure and liquid part, known by the name of molasses, escapes; while the remaining part is converted into a mass of small and hard granules of a brownish or whitish color, known by the designation of raw sugar, which when imported into Europe is further purified by an additional process, and converted by filtration or crystallization into what is called loaf sugar, or refined sugar, or candied sugar. The juice of the acer saccharinum, or American maple, yields sugar in such considerable abundance as to make it an object with the North American farmer to manufacture it for his own use. A hole is bored in the trunk of the vegetating tree early in the spring, for the purpose of extracting the sap; of which a tree of ordinary size, that is, of from two to three feet in diameter, will yield from one hundred and fifty to two hundred pints and upwards, in a good season. The sap, when thus obtained and neutralised by lime, deposits, by evaporation, crystals of sugar in the proportion of about a pound of sugar to forty pints of sap. It is not materially different in its properties from that of the sugar-cane. The juice of the grape, when ripe, yields also a sugar by evaporation and the action of pot-ashes, which is known by the appellation of the sugar of grapes, and has been lately employed in France as a substitute for colonial sugar, though it is not so sweet or agreeable to the taste. The root of beta vulgaris, or common beet, yields also, by boiling and evaporation, a sugar which is distinguished by a peculiar and slightly bitter taste, owing perhaps to the presence of a bitter extractive matter which has been found to be one of the constituents of the beet. Sugar has been extracted from the following vegetables also, or from their productions: from the sap of the birch, sycamore, bamboo, maize, parsnep, cow-parsnep, American aloe, dulse, walnut-tree, and cocoa-nut-tree; from the fruit of the common arbutus, and other sweet-tasted fruits; from the roots of the turnip, carrot, and parsley; from the flower of the euxine rhododendron; and from the nectary of most other flowers.

1373. *The utility of sugar*, as an aliment, is well known; and it is as much relished by many animals as by man. By bees it is sipped from the flowers of plants, under the modification of nectar, and converted into honey; and also seems to be relished by many insects, even in its concrete state; as it is also by many birds. By man it is now regarded as being altogether indispensable, and though used chiefly to give a relish or seasoning to food, is itself highly nutritive. It is also of much utility in medicine, and celebrated for its anodyne and antiseptic qualities, as well as thought to be peculiarly efficacious in preventing diseases by worms.

1374. *Starch*. If a quantity of wheaten flour is made into a paste with water, and kneaded and washed under the action of a jet, till the water runs off colorless, part of it will be found to have been taken up and to be still held in suspension by the water, which will, by-and-by, deposit a sediment that may be separated by decantation. This sediment is starch, which may be obtained also immediately from the grain itself, by means of a process well known to the manufacturer, who renders it finally fit for the market by washing and edulcorating it with water, and afterwards drying it by a moderate heat. Starch, when thrown upon red-hot iron, burns with a kind of explosion, and leaves scarcely any residuum behind. It has been found by the analysis of Gay Lussac and Thenard, to be composed of carbon 43.55; oxygen 49.68; hydrogen 6.77; total 100. This result is not very widely different from that of the analysis of sugar, into which, it seems, starch may be converted by diminishing the proportion of its carbon, and increasing that of its oxygen and hydrogen. This change is exemplified in the case of the malting of barley, which contains a great proportion of starch, and which absorbs during the process a quantity of oxygen, and evolves a quantity of carbonic acid; and accordingly part of it is converted into sugar. Perhaps it is exemplified also in the case of the freezing of potatoes, which acquire in consequence a sweet and sugary taste, and are known to contain a great deal of starch, which may be obtained as follows: let the potatoes be taken and grated down to a pulp, and the pulp placed upon a fine sieve, and water made to pass through it: the water will be found to have carried off with it an infinite number of particles,

which it will afterwards deposit in the form of a fine powder, separable by decantation; which powder is starch, possessing all the essential properties of wheaten starch. It may be obtained from the pith of several species of palms growing in the Moluccas and several other East India islands, by the following process: the stem, being first cut into pieces of five or six feet in length, is split longitudinally so as to expose the pith, which is now taken out and pounded, and mixed with cold water, which after being well stirred up, deposits at length a sediment that is separated by decantation, and is the starch which the pith contained, or the sago of the shops.

1375. *Salop* is also a species of starch that is prepared, in the countries of the East, from the root of the orchis morio, mascula, bifolio, and pyramidalis, and in the isle of Portland, from the arum maculatum. So also is cassava, which is prepared from the root of jatropha manihot, a native of America, the expressed juice of which is a deadly poison, used by the Indians to poison their arrows; but the sediment which it deposits is a starch that is manufactured into bread, retaining nothing of the deleterious property of the juice; and so also is sowans, which is prepared from the husk of oats, as obtained in the process of grinding.

1376. *Starch may be extracted from a number of plants*; as arctium lappa, atropa belladonna, polygonum bistorta, bryonia alba, colchicum autumnale, spiraea filipendula, ranunculus bulbosus, serophalaria nodosa, sambucus ebulus and nigra, orchis morio and mascula, imperatoria ostruthium, hyoseyamus niger, rumex obtusifolius, acutus, and aquaticus, arum maculatum, iris pseudacorus and fetidissima, orobus tuberosus, bunion bulbocastanum. It is found also in the following seeds: wheat, barley, oats, rice, maize, millet-seed, chestnut, horse-chestnut, peas, beans, acorns.

1377. *Starch is an extremely nutritive substance*, and forms one of the principal ingredients in almost all articles of vegetable food used, whether by man or the inferior animals. The latter feed upon it in the state in which nature presents it; but man prepares and purifies it so as to render it pleasing to his taste, and uses it under the various modifications of bread, pastry, or confectionery. Its utility is also considerable in medicine and in the arts; in the preparation of anodyne and strengthening medicaments, and in the composition of cements; in the clearing and stiffening of linen; and in the manufacture of hair-powder.

1378. *Gluten* is that part of the paste formed from the flour of wheat that remains unaffected by the water after all the starch contained in it has been washed off. It is a tough and elastic substance, of a dull white color, without taste, but of a very peculiar smell. It is soluble in the acids and alkalies, but insoluble in water and in alcohol. Gluten has been detected, under one modification or other, in a very considerable number of vegetables or vegetable substances, as well as in the flour of wheat.

1379. *Gluten is one of the most important of all vegetable substances*, as being the principle that renders the flour of wheat so fit for forming bread, by its occasioning the panary fermentation, and making the bread light and porous. It is used also as a cement, and capable of being used as a varnish, and a ground for paint.

1380. *Albumen*, which is a thick, gummy, and tasteless fluid, resembling the white of an unboiled egg, is a substance that has been but lately proved to exist in the vegetable kingdom. Its existence was first announced by Fourcroy, and finally demonstrated by the experiments of Vauquelin on the dried juice of the papaw-tree. It is nearly related to animal gluten.

1381. *Fibrina* is a peculiar substance which chemists extract from the blood and muscles of animals. This substance constitutes the fibrous parts of the muscles, and resembles gluten in its appearance and elasticity. A substance possessing the same properties has been detected by Vauquelin in the juice of the papaw-tree, which is called vegetable fibrina.

1382. *Extract*. When vegetable substances are macerated in water, a considerable portion of them is dissolved; and if the water is again evaporated, the substance held in solution may be obtained in a separate state. This substance is denominated extract. But it is evident that extract thus obtained will not be precisely the same principle in every different plant, but will vary in its character according to the species producing it, or the soil in which the plant has grown, or some other accidental cause. Its distinguishing properties are the following:—it is soluble in water as it is obtained from the vegetable, but becomes afterwards insoluble in consequence of the absorption of oxygen from the atmosphere. It is soluble in alcohol; and it unites with alkalies, and forms compounds which are soluble in water. When distilled it yields an acid fluid impregnated with ammonia, and seems to be composed principally of hydrogen, oxygen, carbon, and a little nitrogen. Extract, or the extractive principle, is found in a greater or less proportion in almost all plants whatever; and is very generally an ingredient of the sap and bark, particularly in barks of an astringent taste. But still it is not exactly the same in all individual plants, even when separated as much as possible from extraneous substances. It may therefore, be regarded as constituting several different species, of which the following are the most remarkable:

1385. *Extract of catechu*. This extract is obtained from an infusion of the wood or powder of catechu in cold water. Its color is pale brown; and its taste slightly astringent. It is precipitated from its solution by nitrate of lead, and yields by distillation carbonic and carburetted hydrogen gas, leaving a porous charcoal.

1384. *Extract of senna*. This extract is obtained from an infusion of the dried leaves of cassia senna in alcohol. The color of the infusion is brownish, the taste slightly bitter, and the smell aromatic. It is precipitated from its solution by the muriatic and oxy-muriatic acids; and when thrown on burning coals consumes, with a thick smoke and aromatic odor, leaving behind a spongy charcoal.

1385. *Extract of quinquina*. This extract was obtained by Fourcroy, by evaporating a decoction of the bark of the quinquina of St. Domingo in water, and again dissolving it in alcohol, which finally deposited by evaporation the peculiar extractive. It is insoluble in cold water, but very soluble in boiling water; its color is brown, and its taste bitter. It is precipitated from its solution by lime water, in the form of a red powder; and when dry it is black and brittle, breaking with a polished fracture.

1386. *Extract of saffron*. This extract is obtained in great abundance from the summits of the pistils of crocus sativus, which are almost wholly soluble in water.

1387. *Extracts were formerly much employed in medicine*; though their efficacy seems to have been overrated. But a circumstance of much more importance to society is that of their utility in the art of dyeing. By far the greater part of colors used in dyeing are obtained from vegetable extracts, which have a strong affinity to the fibres of cotton or linen, with which they enter into a combination that is rendered still stronger by the intervention of mordants.

1388. *Coloring matter*. The beauty and variety of the coloring of vegetables, chemists have ascribed to the modifications of a peculiar substance which they denominate the coloring principle, and which they have accordingly endeavored to isolate and extract; first, by means of maceration or boiling in water, and then by precipitating it from its solution. The chemical properties of coloring matter seem to be as yet but imperfectly known, though they have been considerably elucidated by the investigations of Bertholet, Chaptal, and others. Its affinities to oxygen, alkalies, earths, metallic oxides, and cloths fabricated, whether of animal or vegetable substances, such as wool or flax, seem to be among its most striking characteristics. But its affinity to animal substances is stronger than its affinity to vegetable substances; and hence wool and silk assume a deeper dye, and retain it longer than cotton or linen. Coloring matter exhibits a great variety of different tints, as it occurs in different species of plants; and as it combines with oxygen, which it absorbs from the atmosphere, it assumes a deeper shade; but it loses at the same time a portion of its hydrogen, and becomes insoluble in water; and thus it indicates its relation to extract. Fourcroy reduced colors to the four following sorts; extractive colors, oxygenated colors, carbonated colors, and hydrogenated colors; the first being soluble in water, and requiring the aid of saline or metallic mordants to fix them upon cloth; the second being insoluble in water, as altered by the absorption of oxygen, and requiring no mordant to fix them upon cloth; the third containing in their composition a great proportion of carbon, but soluble in alkalies; and the fourth containing a great proportion of resin, but soluble in oils and alcohol. But the simplest mode of arrangement is that by which the dif-

ferent species of coloring matter are classed according to their effect in the art of dyeing. The principal and fundamental colors in this art are the blue, the red, the yellow, and the brown.

1389. *The finest of all vegetable blues* is that which is known by the name of indigo. It is the produce of the *indigofera tinctoria*, Lin., a shrub which is cultivated for the sake of the dye it affords, in Mexico and the East Indies. The plant reaches maturity in about six months, when its leaves are gathered and immersed in vessels filled with water till fermentation takes place. The water then becomes opaque and green, exhaling an odor like that of volatile alkali, and evolving bubbles of carbonic acid gas. When the fermentation of the dye is continued long enough, the liquid is decanted and put into other vessels, where it is agitated till blue flakes begin to appear. Water is now poured in, and flakes are precipitated in the form of a blue powdery sediment, which is obtained by decantation; and which, after being made up into small lumps and dried in the shade, is the indigo of the shops. It is insoluble in water, though slightly soluble in alcohol. But its true solvent is sulphuric acid, with which it forms a fine blue dye, known by the name of liquid blue. It affords by distillation carbonic acid gas, water, ammonia, some oily and acid matter, and much charcoal; whence its constituent principles are most probably carbon, hydrogen, oxygen, and nitrogen. Indigo may be procured also from several other plants besides *indigofera tinctoria*, and particularly from *isatis tinctoria* or woad, a plant indigenous to Britain, and thought to be the plant with the juice of which the ancient Britons stained their naked bodies, to make them look terrible to their enemies. If this plant is digested in alcohol, and the solution evaporated, white crystalline grains, somewhat resembling starch, will be left behind; which grains are indigo, becoming gradually

blue by the action of the atmosphere. The blue color of indigo, therefore, is owing to its combination with oxygen.

1390. *The principal red colors* are such as are found to exist in the root, stem, or flower, of the five following plants: *rubia tinctorum*, *lichen*, *rocceola* and *parellus*, *carthamus tinctorius*, *cæsalspinia crista*, and *haematoylon campechianum*.

1391. *Yellow*, which is a color of very frequent occurrence among vegetables, and the most permanent among flowers, is extracted for the purpose of dyeing, from a variety of plants. It is extracted from the *reseda luteola*, Lin., by the decoction of its dried stems. The coloring matter is precipitated by means of alum, and is much used in dyeing wool, silk, and cotton. It is also obtained from the *morus tinctoria*, *bixa orellana* or *arnotta*, *serratula tinctoria*, *genista tinctoria*, *rhus cotinus*, *rhamnus infectorius*, and *quercus tinctoria*, or *quercitron*, the bark of which last affords a rich and permanent yellow that is at present much in use.

1392. *The brown coloring matter of vegetables* is very abundant, particularly in astringent plants. It is obtained from the root of the walnut-tree, and rind of the walnut; as also from the sumac and elder, but chiefly from nut-galls, which are excrescences formed upon the leaves of a species of *quercus*, indigenous to the south of Europe, in consequence of the puncture of insects. The best in quality are brought from the Levant. They are sharp and bitter to the taste, and extremely astringent; and soluble in water by decoction when ground or grated to a powder. The decoction strikes, with the solution of iron, a deep black, that forms the basis of ink, and of most dark colors used in dyeing cloths.

1393. *Tannin*. If a quantity of pounded nut-galls, or bruised seeds of the grape, is taken and dissolved in cold water, and the solution evaporated to dryness, there will be left behind a brittle and yellowish substance of a highly astringent taste, which substance is tannin, or the tanning principle. It is soluble both in water and alcohol, but insoluble in ether. With the salts of iron it strikes a black. And when a solution of gelatine is mixed with an aqueous solution of tannin, the tannin and gelatine fall down in combination, and form an insoluble precipitate. When tannin is subjected to the process of distillation, it yields charcoal, carbonic acid, and inflammable gases, with a minute quantity of volatile alkali, and seems accordingly to consist of the same elements with extract, from which, however, it is distinguished by the peculiar property of its action upon gelatine. Tannin may be obtained from a great variety of other vegetables also, as well as those already enumerated, but chiefly from their bark; and of barks, chiefly from those that are astringent to the taste. The following table exhibits a general view of the relative value of different species of bark, as ascertained by Sir Humphry Davy. It gives the average obtained from 450lb. of the entire bark of a middle-sized tree of the several different species, taken in the spring, when the quantity of tannin is the largest.

	lb.		lb.		lb.
Oak	29	Beech	10	Black thorn	16
Spanish chestnut	21	Horse-chestnut	9	Coppice oak	32
Leicester willow (large)	35	Sycamore	11	Inner rind of oak-bark	75
Elm	15	Lombardy poplar	15	Oak cut in autumn	21
Common willow (large)	11	Birch	8	Larch cut in autumn	8
Ash	16	Hazel	14		

1394. *Tannin is of the very first utility in its application to medicine and the arts*; being regarded by chemists as the general principle of astringency. The medical virtues of Peruvian bark, so celebrated as a febrifuge and antiseptic, are supposed to depend upon the quantity and quality of its tannin. In consequence of its peculiar property of forming an insoluble compound with gelatine, the hides of animals are converted into leather, by the important art of tanning. The bark of the oak-tree, which contains tannin in great abundance, is that which is most generally used by the tanner. The hides to be tanned are prepared for the process by steeping them in lime-water, and scraping off the hair and cuticle. They are then soaked, first in weaker and afterwards in stronger infusions of the bark, till at last they are completely impregnated. This process requires a period of from ten to eighteen months, if the hides are thick; and four or five pounds of bark are necessary on an average to form one pound of leather.

1395. *Bitter principle*. The taste of many vegetables, such as those employed in medicine, is extremely bitter. The quassia of the shops, the roots of the common gentian, the bark and wood of common broom, the calyx and floral leaves of the hop, and the leaves and flowers of chamomile, may be quoted as examples. This bitter taste has been thought to be owing to the presence of a peculiar substance, different from every other vegetable substance, and has been distinguished by the name of the bitter principle. When water has been digested for some time over quassia, its color becomes yellow, and its taste intensely bitter; and if it is evaporated to dryness, it leaves behind a substance of a brownish yellow, with a slight degree of transparency, that continues for a time ductile, but becomes afterwards brittle. This substance Dr. Thomson regards as the bitter principle in a state of purity. It is soluble in water and in alcohol; but the solution is not much affected by re-agents. Nitrate of silver and acetate of lead are the only two that occasion a precipitate. The bitter principle is of great importance, not only in the practice of medicine, but also in the art of brewing; its influence being that of checking fermentation, preserving the fermented liquor, and when the bitter of the hop is used, communicating a peculiar and agreeable flavor. The bitter principle appears to consist principally of carbon, hydrogen, and oxygen, with a little nitrogen.

1396. *Narcotic principle*. There is a species of medical preparations known by the name of narcotics, which have the property of inducing sleep; and if administered in large doses, of occasioning death. They are obtained from the milky and proper juices of some vegetables, and from the infusion of the leaves or stem of others, all which have been supposed to contain in their composition some common ingredient, which chemists have agreed to designate by the name of the narcotic principle. It exists in great abundance in opium, which is the concrete juice of *papaver album*, or the white poppy, from which it is obtained pure, in the form of white crystals. It is soluble in boiling water and in alcohol, as well as in all acid menstrua; and it appears that the action of opium on the animal subject depends on this principle. When distilled it emits white vapors, which are condensed into a yellow oil. Some water and carbonate of ammonia pass into a receiver; and at last carbonic acid gas, ammonia, and carburetted hydrogen, are disengaged, and a bulky charcoal left behind. Many other vegetable substances besides opium possess narcotic qualities though they have not yet been minutely analysed. The following are the most remarkable: — the inspissated juice of lettuce, which resembles opium much in its appearance, is obtained by the same means, and possesses the same medical virtues; the leaves of *atropa belladonna*, or deadly nightshade, and indeed the whole plant; the leaves of *digitalis purpurea*, or foxglove; and lastly, the following plants, *hyoscyamus niger*, *conium maculatum*, *datura stramonium*, and *sedum palustre*, with many others belonging to the Linnean natural order of *Luridae*.

1397. *Acids*. Acids are a class of substances that may be distinguished by their exciting on the palate the sensation of sourness. They exist, not only in the animal and mineral, but also in the vegetable kingdom; and such of them as are peculiar to vegetables have been denominated vegetable acids. Of acids peculiar to vegetables chemists enumerate the following: — the oxalic, acetic, citric, malic, gallic, tartaric, benzoic, and prussic, which exist ready formed in the juices or organs of the plant, and are ac-

cordingly denominated native acids; together with the mucous, pyromucous, pyrotartarous, pyrolignous, camphoric, and suberic, which do not exist ready formed in the plant, and are hence denominated artificial acids. They are consequently not within the scope of the object of the present work.

1398. *Oxalic acid.* If the expressed juice of the oxalis acetosella is left to evaporate slowly, it deposits small crystals of a yellowish color and saltish taste, which are known by the name of the elcer arictinum, of which it forms a certain part. It is obtained also by Scheele from the sap of the sambucus nigra; and is consequently to be regarded as a native vegetable acid. It is distinguished from other vegetable acids by its forming soluble salts with the alkalis and earths.

1399. *Acetic acid.* The acetic acid, or vinegar, which is generally manufactured from wine in a certain stage of fermentation, has been found also ready formed in the sap of several trees, as analysed by Vanquelin; and also in the acid juice of the elcer arictinum, of which it forms a certain part. It was obtained also by Scheele from the sap of the sambucus nigra; and is consequently to be regarded as a native vegetable acid. It is distinguished from other vegetable acids by its forming soluble salts with the alkalis and earths.

1400. *Citric acid.* Citric acid is the acid that exists in the juice of lemon. Its solution is very sour in a state of purity, but exceedingly pleasant when diluted with water. By a red heat it yields carbonic acid gas and carbonated hydrogen gas, and is reduced to a charcoal; nitric acid converts it into oxalic and acetic acid, and with lime it forms a salt insoluble in water. It has been found unmixed with other acids in the following vegetable substances: the juice of oranges and lemons, and in the berries of vaccinium oxycoccus, and vitis idæa, prunus padus, solanum dulcamara, and rosa canina. It has been found also in many other fruits, mixed with other acids.

1401. *Malic acid.* Malic acid is found chiefly in the juice of unripe apples, whence it derives its name. But it is found also in the juice of hawberries, alderberries, gooseberries, plums, and common house-leek.

1402. *Gallic acid.* Gallic acid, as it is obtained in the greatest abundance, so it derives its name from the nut-gall, from which it may be extracted by exposing a quantity of the powder of nut-galls to a moderate heat in a glass retort; and the acid will sublime and form crystals of an octahedral figure. Its taste is austere and astringent. It strongly reddens vegetable

1406. *All vegetable acids contain carbon, oxygen, and hydrogen, in one proportion or other; and the prussic acid contains also a portion of nitrogen.* The gallic acid contains more of carbon than any other vegetable acid, and the oxalic more of oxygen.

1407. *Vegetable oils* are of two kinds, the fixed and the volatile. The former are not suddenly affected by the application of heat; the latter are very inflammable.

1408. *Fixed oils.* Fixed oils are but seldom found, except in the seeds of plants, and chiefly in such as are dicotyledonous. They are found also, though rarely, in the pulp of fleshy fruits, as in that of the olive, which yields the most abundant and valuable species of all fixed oils. But dicotyledonous seeds, which contain oil, contain also at the same time a quantity of muclage and fecula, and form, when bruised in water, a mild and milky fluid, known by the name of emulsion. And on this account they are sometimes denominated emulsive seeds. Some seeds yield their oil merely by means of pressure, though it is often necessary to reduce them first of all to a sort of pulp, by means of pounding them in a mortar. Others require to be exposed to the action of heat, which is applied to them by means of pressure between warm plates of tin, or of the vapor of boiling water, or of roasting before they are subjected to the press. Fixed oil, when pure, is generally a thick and viscous fluid, of a mild or insipid taste, and without smell. But it is never entirely without some color, which is for the most part green or yellow. Its specific gravity is to water as 9:403 to 1:000. It is insoluble in water. It is decomposed in the acids, but with the alkalis it forms soap. When exposed to the atmosphere it becomes inspissated and opaque, and assumes a white color and a resemblance to fat. This is in consequence of the absorption of oxygen; but owing to the appearance of a quantity of water in oil that is exposed to the action of the air, it has been thought that the oxygen absorbed by it is not yet perhaps assimilated to its substance. When exposed to cold it congeals and crystallizes, or assumes a solid and granular form; but not till the thermometer has indicated a degree considerably below the freezing point. When exposed to the action of heat it is not volatilized till it begins to boil, which is at 600° of Fahrenheit. By distillation it is converted into water, carbonic acid, and carburetted hydrogen gas, and charcoal; the product of its combustion is nearly the same; and hence it is a compound of carbon, oxygen, and hydrogen. Fixed oils are generally divided into two sorts, fat oils and drying oils. The former are readily inspissated by the action of the air, and converted into a sort of fat. The latter are capable of being dried by the action of the air, and converted into a firm and transparent substance.

1409. *The principal species of fat oils are the following:—*

1410. *Olive-oil,* which is expressed from the pulpy part of the fruit of olea europea. The fruit is first broken in a mill, and reduced to a sort of paste. It is then subjected to the action of a press, and the oil is now easily separated, swims on the top of the water in the vessel beneath. It is manufactured chiefly in France and in Italy, and is much used throughout Europe instead of butter, and to give a seasoning to food.

1411. *Oil of almonds,* which is extracted from the fruit of the amygdalus communis or common almond. The almonds are first well rubbed or shook in a coarse bag or sack, to separate a bitter powder which covers their epidermis. They are then

1414. *The principal species of drying oils are linseed-oil, nut-oil, poppy-oil, and hempseed-oil.*

1415. *Linseed oil* is obtained from the seeds of flax, which are generally roasted before they are subjected to any other process, for the purpose of drying up their muclage and separating more oil.

1416. *Nut-oil* is extracted from the fruit of corylus avellana, or juglans regia. The kernel is first slightly roasted, and the oil then expressed. It is used in paintings of a coarser sort; and also in the seasoning of food by many of the inhabitants of the middle departments of France; but it is apt to become rancid.

1419. *Volatile oils.* Volatile oils, which are known also by the name of essential oils, are of very common occurrence in the vegetable kingdom, and are found in almost all the different organs of the plant. They are found in many roots, to which they communicate a fragrant and aromatic odor, with a taste somewhat acrid. The roots of inula helenium, genista canariensis, and a variety of other plants, contain essential oils. They are found also in the bark of laurus cinnamomum, of laurus sassafras, and pinus; in the leaves of labiate plants, such as mint, rosemary, marjoram; and of the odorous umbelliferae, such as chervil,

blies. It is soluble both in water and alcohol; and is distinguished by its property of communicating to solutions of iron a deep purple color. When exposed to a gentle heat it sublimes without alteration, but a strong heat decomposes it. Nitric acid converts it into the malic and oxalic acids. It is of great utility in the art of dyeing, and forms the basis of all black colors, and of colors with a dark ground. It forms also the basis of ink; and chemists use it as a test to detect the presence of iron.

1405. *Tartaric acid.* If wine is kept for a length of time in a cask or other close vessel, a sediment is precipitated which adheres to the sides or bottom, and forms a crust known by the name of tartar, which is a combination of potass and a peculiar acid in excess. The compound is tartarite of potass, and the acid, in its state of purity, is the tartaric acid. It is characterized by the property of its forming with potass a salt that is soluble with difficulty. It has been found in the following vegetable substances also: in the pulp of tamarinds, in the juice of the grape, and mulberries, sorrel, and sumac, and the roots of triticum repens, and leontodon taraxacum. It is not much used except among chemists. But the tartarite from which it is usually obtained is well known for its medical virtues under the name of cream of tartar.

1404. *Benzoin acid.* From the strax benzoin there exudes a resinous substance, known in the shops by the name of benzoin, and in which the benzoic acid is contained. It is distinguished from the other acids by the aromatic odor and extreme volatility. It has been obtained also from the balsams of tolu and storax; and is used in pharmacy, in the preparation of boluses and electuaries.

1405. *Prussic acid.* The prussic acid is generally classed among the animal acids, because it is obtained in the greatest abundance from animal substances. But it has been proved to exist in vegetable substances also, and it is procured by distilling laurel leaves, or the kernels of the peach and cherry, or bitter-almonds. When pure it exists in the form of colorless fluid, with an odor resembling that of peach-tree blossoms. It does not redden vegetable blues. But it is characterised by its property of forming a bluish-green precipitate, when it is poured, with a little alkali added to it, into solutions containing iron.

pounded to a paste in mortars of marble, which is afterwards subjected to the action of the press; and the oil is now obtained as in the olive.

1412. *Rapeseed-oil,* which is extracted from the brassica napus and campestris. It is less fixed and less liable to become rancid than the two former, and is manufactured chiefly in Flanders.

1413. *Oil of behen,* which is extracted from the fruit of the gullandina mohringa, common in Egypt and Africa. It is apt to become rancid; but it is without odor, and is on this account much used in perfumery.

1413. *Oil of behen,* which is extracted from the fruit of the gullandina mohringa, common in Egypt and Africa. It is apt to become rancid; but it is without odor, and is on this account much used in perfumery.

1417. *Poppy-oil* is extracted from the seeds of papaver somniferum, which is cultivated in France and Holland for this purpose. It is clear and transparent, and dries readily; and when pure it is without taste or odor. It is used for the same purposes as the olive-oil, for which it is often sold, and possesses nothing of the narcotic properties of the poppy.

1418. *Hempseed-oil* is extracted from the seed of the hemp. It has a harsh and disagreeable taste, and is used by painters in this country, and very extensively for food in Russia.



fennel, angelica; and of plants with compound flowers, such as wormwood. They are found also in the flower itself, as in the flowers of chamomile, and the rose; and in the fruit, as in that of pepper and ginger, and in the external integuments of many seeds, but never in the cotyledon. They are extracted by means of expression or distillation, and are extremely numerous; and perhaps every plant possessing a peculiar odor possesses also a peculiar and volatile oil. The aroma of plants, therefore, or the substance from which they derive their odor, and which is cognisable only by the sense of smell, is perhaps merely the more volatile and evaporable part of their volatile oil, disengaging itself from its combinations. Volatile oils are characterised by their strong and aromatic odor, and rather acrid taste. They are soluble in alcohol, but are not readily converted into soaps by alkalis. They are very inflammable, and are volatilised by a gentle heat. Like fixed oils, their specific gravity is generally less than that of water, on the surface of which they will float; though in some cases it is found to be greater than that of water, in which they consequently sink. They are much in request on account of their agreeable taste and odor, and are prepared and sold by apothecaries and perfumers, under the names of distilled waters or essences; as well as employed also in the manufacture of varnishes and pigments.

1420. *Wax.* On the upper surface of the leaves of many trees there may often be observed a sort of varnish, which, when separated by certain chemical processes, is found to possess all the properties of bees'-wax, and is consequently a vegetable wax. It exudes, however, from several other parts of the plant besides the leaf, and assumes a more waxy and concrete form, as from the catkins of the poplar, the alder, and the fir; from the fruit of the myrica cerifera and croton sebiferum; but particularly from the antheræ of the flowers, from which it is probable that the bees extract it unaltered. It was the opinion of Reaumur, however, that the pollen undergoes a digestive process in the stomach of the bee before it is converted into wax, though a late writer on the subject endeavours to prove that the wax is elaborated from the honey extracted by the bee, and not from the pollen. It is found also in the interior of many seeds, from which it is extracted, by means of pounding them and boiling them in water. The wax is melted and swims on the top. Wax, when pure, is of a whitish color, but without taste and without smell. The smell of bees'-wax is indeed somewhat aromatic, and its color yellow. But this is evidently owing to some foreign substance with which it is mixed, because it loses its smell and color by means of bleaching, and becomes perfectly white. This is done merely by drawing it out into thin stripes, and exposing it for some time to the atmosphere. Bleached wax is not affected by the air. Its specific gravity is 0.9600. It is insoluble in water, and in alcohol. It combines with the fixed oils, and forms with them a composition known by the name of cerate. It combines also with the fixed alkalis, and forms with them a compound possessing the properties of common soap. The acids have but little action on it, and for this reason it is useful as a lute to confine them, or to prevent them from injuring cork. When heat is applied to wax it becomes soft, and melts at the temperature of 142° if unbleached, and of 155° if bleached, into a colorless and transparent fluid, which, as the temperature diminishes, concretes again and resumes its former appearance. At a higher temperature it boils and evaporates, and the vapor may be set on fire by the application of red heat. Hence its utility in making candles. And hence an explication of the singular phenomenon observable in the diatamnus fraxinella. This plant is fragrant, and the odor which it diffuses around forms a partial and temporary atmosphere, which is inflammable; for if a lighted candle or other ignited body is brought near to the plant, especially in the time of drought, its atmosphere immediately takes fire. This phenomenon was first observed by the daughter of the celebrated Linnæus, and is explained by supposing the partial and temporary atmosphere to contain a proportion of wax exuded from the plant, and afterwards reduced to vapor by the action of the sun. The result of its combustion in oxygene gas was, according to Lavoisier, carbonic acid and water, in such proportion as to lead him to conclude that 100 parts of wax are composed of 82.23 of carbon and 17.72 of hydrogen. But owing to the little action of acids upon it, there seems reason to believe that it contains also oxygen as an ingredient.

1421. *Wax possesses all the essential properties of a fixed oil.* But fixed oils have the property of becoming concrete, and of assuming a waxy appearance when long exposed to the air, in consequence, as it seems, of the absorption of oxygen. Wax therefore may be considered as a fixed oil rendered concrete, perhaps by the absorption of oxygen during the progress of vegetation. But if this theory is just, the wax may be expected to occur in a considerable variety of states according to its degree of oxygenation; and this is accordingly the case. Sometimes it has the consistency of butter, and is denominated butter of wax, as butter of cocoa, butter of galam. Sometimes its consistency is greater, and then it is denominated tallow, as tallow of croton; and when it has assumed its last degree of consistency, it then takes the appellation of wax. The following are its principal species: butter of cacao, butter of cocoa, butter of nutmeg, tallow of croton, and wax of myrtle.

1422. *The butter of cacao* is extracted from the seeds of the theobroma cacao or chocolate plant, either by boiling them in water, or by subjecting them to the action of the press after having exposed them to the vapor of boiling water.

1423. *Butter of cocoa* is found in the fruit of cocus nucifera or cocoa-nut-tree. It is expressed from the pulp of the nut, and is even said to separate from it when in a fluid state, as cream separates from milk.

1427. *Resins.* Resins are volatile oils, rendered concrete by means of the absorption of oxygen, or rather perhaps by the abstraction of part of their hydrogen. They have a slight degree of transparency, and their color is generally yellowish. Their taste is somewhat acrid; but they are without smell when pure. Their specific gravity varies from 1.0180 to 1.2289. They are non-conductors of electricity, and when excited by friction their electricity is negative. The species of resins are numerous.

1428. *Rosin* is a species of resin, of which there are several varieties. — From different species of the pine, larch, and fir-tree, there exudes a juice which concretes in the form of tears. Its extraction is generally aided by means of incisions, and it receives different appellations, according to the species from which it is obtained. If it is obtained from the pinus sylvestris, it is denominated *common turpentine*; from pinus larix, *Venice turpentine*; from amyris balsamæ, *balsam of Canada*. It consists of two ingredients, oil of turpentine and rosin. The oil is extricated by distillation, and the rosin remains behind. If the distillation is continued to dryness, the residuum is *common rosin* or colophonium; but if water is mixed with it while yet fluid, and incorporated by violent agitation, the residuum is *yellow rosin*. The yellow rosin is the most ductile, and the most generally used in the arts.

1429. *Pitch and tar* are manufactured from the resinous juices of the fir. The trunk is cut or cleft into pieces of a convenient size, which are piled together in heaps, and covered with turf. They are then set on fire, and the resinous juice which is thus extricated, being prevented from escaping in a volatile state by means of the turf, is precipitated and collected in a vessel beneath. It is partly converted into an empyreumatic oil, and is now tar, which, by being further inspissated, is converted into pitch.

1430. *Mastic* is extracted from the pistacia lentiscus.

1431. *Sandarach* is obtained from the juniperis communis, by spontaneous exudation.

1432. *Elemi* is extracted from the amyris elemifera.

1433. *Tacamahac* is the produce of the fagara octandra and populus balsamifera.

1434. *Labdanum* is obtained from the cistus creticus.

1424. *Butter of nutmeg* is obtained from the seeds of the myristica officinalis, or nutmeg-tree.

1425. *Tallow of croton* is obtained from the fruit of the croton sebiferum.

1426. *The wax of myrtle* is obtained from the berry of the myrica cerifera.

1429. *Opobalsamum, or balm of Gilead*, which has been so much famed for its medical virtues, is the produce of the amyris gileadensis, a shrub which grows in Judæa and in Arabia; but it is so much valued by the Turks that its importation is prohibited. This is the balm of Gilead so much celebrated in Scripture. Pliny says it was first brought to Rome by the generals of Vespasian. It is obtained in a liquid state from incisions made in the bark, and is somewhat bitter to the taste.

1436. *Copaiva, or balsam of copaiva*, is obtained from the copalifera officinalis.

1437. *Dragon's blood* is obtained from the dracæna draco, pterocarpus draco, and calamus rotang.

1438. *Guaiac* is the produce of the guaiacum officinale.

1439. *Botany Bay resin*, the produce of the acarolis resinifera, a native of New Holland, and found in great abundance about Botany Bay.

1440. *Green resin* constitutes the coloring matter of the leaves of trees, and of almost all vegetables. It is insoluble in water, but soluble in alcohol. When treated with oxymuriatic acid, it assumes the color of a withered leaf, and exhibits the resinous properties more distinctly.

1441. *Copal* is the produce of the rhus copallinum, a tree which is found in North America.

1442. *Anise*, is obtained from the hymenæa coubaril, or locust-tree, a native of North America.

1443. *Lac* is the produce of the croton laciferum, a native of the East Indies.

1444. *Bloom.* Upon the epidermis of the leaves and fruit of certain species of plants, there is to be found a fine, soft, and glaucous powder. It is particularly observable upon cabbage-leaves, and upon plums, to which it communicates a pecu-

lar shade. It is known to gardeners by the name of bloom. It is easily rubbed off by the fingers; and when viewed under the microscope seems to be composed of small opaque and unpolished granules, somewhat similar to the powder of starch; but with a high magnifying power it appears transparent.

When rubbed off, it is again re-produced, though slowly. It resists the action of dew and rains, and is consequently insoluble in water. But it is soluble in spirits of wine; from which circumstance it has been suspected, with some probability, to be a resin.

1445. *The use of resins in the arts is very considerable; but their medical virtues are not quite so great as has been generally supposed. They are employed in the arts of painting, varnishing, embalming, and perfumery; and they furnish us with two of the most important of all materials to a naval power, pitch and tar.*

1446. *Gum-resins.* This term is employed to denote a class of vegetable substances, which have been regarded by chemists as consisting of gum and resin. They are generally contained in the proper vessels of the plant, whether in the root, stem, branches, leaves, flowers, or fruit. But there is this remarkable difference between resins and gum-resins, that the latter have never been known, like the former, to exude spontaneously from the plant. They are obtained by means of bruising the parts containing them, and expressing the juice, which is always in the state of an emulsion, generally white, but sometimes of a different color; or they are obtained by means of incisions from which the juice flows. This juice, which is the proper juice of the plant, is then exposed to the action of the sun, by which, in warm climates, it is condensed and inspissated, and converted into the gum-resin of commerce. Gum-resins, in their solid state, are brittle, and less transparent than resins. They have generally a strong smell, which is sometimes alliaceous, and a bitter and nauseous taste. They are partially soluble both in water and in alcohol. When heated, they do not melt like the resins, nor are they so combustible. But they swell and soften by heat, and at last burn away with a flame. By distillation they yield volatile oil, ammonia combined with an acid, and have a bulky charcoal. The principal species of gum-resins which have been hitherto applied to any useful purpose are:—

1447. *Galbanum*, obtained from the stem of the bubon galbanum.

1448. *Ammoniac*, brought from Africa in the form of small tears; the plant which yields it is thought to be a species of ferula.

1449. *Scammony*, the produce of the convolvulus scammonia.

1450. *Opoponax*, obtained from the pastinaca opopanax.

1451. *Euphorbium*, the produce of the euphorbia officinalis; its taste is caustic; it is considered as a poison, but is occasionally employed in medicine.

1452. *Olibanum* is obtained from the Juniperus lycia, which grows in Arabia, particularly by the borders of the Red Sea. It is the frankincense of the ancients. It exudes from incisions made in the tree, and concretes into masses about the size of a chestnut.

1453. *Sagapenum* is supposed to be obtained from the ferula persica.

1454. *Gamboge*, or gungutt, the produce of the mangostana cambogia.

1455. *Myrrh*, the plant yielding which grows in Abyssinia and Arabia. Bruce says, it belongs to the genus mimosa; but however this may be, myrrh is the juice of the plant concreted in the form of tears. Its color is yellow, its odor strong but agreeable, and its taste bitter; it is employed in medicine, and is esteemed an excellent stomachic.

1456. *Assafetida*, a substance which is well known for its strong and fetid smell, is obtained from the ferula assafetida. At four years old the plant is dug up by the root. The root is then cleaned, and the extremity cut off; a milky juice exudes, which is collected; and when it ceases to flow another part is cut off, and more juice extricated. The process is continued till the root is exhausted. The juice which has been collected soon concretes, and constitutes assafetida. It is brought to Europe in small agglutinated grains of different colors, white, red, yellow. It is hard, but brittle. Its taste is bitter, and its smell insufferably fetid; the Indians use it as a seasoning for their food, and call it the food of the gods. In Europe, it is used in medicine as an antispasmodic.

1457. *Balsams.* The substances known by the name of balsams are resins united to the benzoic acid. They are obtained by means of incisions made in the bark, from which a viscous juice exudes, which is afterwards inspissated by the action of the fire or air, or they are obtained by means of boiling the part that contains them. They are thick and viscid juices, but become readily concrete. Their color is brown or red; their smell aromatic when rubbed; their taste acrid; their specific gravity 1.090. They are unalterable in the air after becoming concrete. They are insoluble in water, but boiling water abstracts part of their acid; they are soluble in the alkalies and nitric acid. When heated they melt and swell, evolving a white and odorless smoke. The principal of the balsams are the following: benzoin, storax, styrax, balsam of tolu, balsam of Peru.

1458. *Benzoin* is the produce of the styrax benzoin.

1459. *Storax* is obtained from the styrax officinale.

1460. *Styrax* is a semi-fluid juice, the produce of a tree said to be cultivated in Arabia.

1461. *Balsam of tolu* is obtained from the toluifera balsamum.

1462. *Balsam of Peru* is obtained from the myroxylon peruvianum.

1463. *Camphor.* The substance known by the name of camphor is obtained from the root and stem of the laurus camphora, by distillation. When pure it is a white brittle substance, forming octagonal crystals or square plates. Its taste is hot and acrid; its odor strong but aromatic; its specific gravity 0.9887. When broke into small fragments and put into water, on the surface of which it swims, a singular phenomenon ensues. The water surrounding the fragments is immediately put into commotion, advancing and retiring in little waves, and attacking the fragments with violence. The minuter fragments are driven backwards and forwards upon the surface as if impelled by contrary winds. If a drop of oil is let fall on the surface of the water it produces an immediate calm. This phenomena has been attributed to electricity. Fourcroy thinks it is merely the effect of the affinities of the camphor, water, and air, entering into combination. Though camphor is obtained chiefly from the laurus camphora, yet it is known to exist in a great many other plants, particularly labiate plants, and has been extracted from the roots of zoadory, sassafras, thyme, rosemary, and lavender.

1464. *Caoutchouc.* The substance denominated caoutchouc was first introduced into Europe about the beginning of the eighteenth century. But from a use to which it is very generally applied of rubbing out the marks made upon paper by a black-lead pencil, it is better known to most people in this country by the name of Indian rubber. It is obtained chiefly from hævea caoutchouc and jatropa elastica, trees indigenous to South America; but it has been obtained also from several trees which grow in the East Indies, such as ficus indicus, artocarpus integrifolia, and urceola elastica. If an incision is made into the bark of any of these plants a milky juice exudes, which, when exposed to the air, concretes and forms caoutchouc. As the object of the natives in collecting it had been originally to form it into vessels for their own use, it is generally made to concrete in the form of bags or bottles. This is done by applying the juice, when fluid, in thin layers to a mould of dry clay, and then leaving it to concrete in the sun or by the fire. A second layer is added to the first, and others in succession, till the vessel acquires the thickness that is wanted. The mould is then broken and the vessel fit for use, and in this state it is generally brought into Europe. It has been brought, however, even in its milky state, by being confined from the action of the air. If the milky juice is exposed to the air, an elastic pellicle is formed on the surface. If it is confined in a vessel containing oxygen gas, the pellicle is formed sooner. If oxymuriatic acid is poured into the milky juice, the caoutchouc precipitates immediately. This renders it probable that the formation of the caoutchouc is owing to the absorption of oxygen. Caoutchouc, when pure, is of a white color, without taste and without smell. The black color of the caoutchouc of commerce is owing to the method of drying the different layers upon the moulds on which they are spread. They are dried by being exposed to smoke. The black color of the caoutchouc, therefore, is owing to the smoke or soot alternating with its different layers. It is soft and pliable like leather, and extremely elastic, so that it may be stretched to a very great length, and still recover its former size. Its specific gravity is 0.9335. Gough, of Manchester, has made some curious and important experiments on the connection between the temperature of caoutchouc and its elasticity, from which it results that ductility as well as fluidity is owing to latent heat. Caoutchouc is not altered by exposure to the air. It is perfectly insoluble in water; but if boiled in water for some time its edges become so soft that they will cement, if pressed and kept for a while closely together. It is insoluble in alcohol, but soluble in ether. It is soluble also in volatile oils and in alk-

lies. And from the action operated upon by acids it is thought to be composed of carbon, hydrogen, oxygen, and azote. It seems to exist in a great variety of plants combined with other ingredients. It may be separated from resins by alcohol. It may be separated from the berries of the missettoe by means of water, and from other vegetable substances by other processes. It is said to be contained both in opium and in mastic. But from these substances it cannot be extracted in sufficient quantities to make it worth the labor. It is applied to a great many useful purposes both in medicine and the arts, to which, from its great pliability and elasticity, it is uncommonly well adapted. In the countries where it is produced the natives make boots and shoes of it, and often use it by way of candle.

1465. *Cork.* The substance known by the name of cork is the outer and exfoliated bark of the quercus suber or cork-tree, a species of oak that grows in great abundance in France, Spain, and Italy. But to prevent its natural exfoliation, which is always irregular, and to disengage it in convenient portions, a longitudinal incision is made in the bark from the root to the top of the stem; and a transverse and circular incision at each extremity. The outer layer, which is cork, is then stripped off, and to flatten and reduce it to sheets it is put into water and loaded with weights. The tree continues to thrive, though it is thus stripped of its cork once in two or three years. Cork is a light, soft, and elastic substance, distinguished by the following properties:—Its color is a sort of light tan. It is very inflammable, and burns with a bright white flame, leaving a black and bulky charcoal behind. When distilled it yields a small quantity of ammonia. Nitric acid corrodes and dissolves it, changing its color to yellow, and finally decomposes it, converting it partly into an acid, and partly into a soft substance resembling wax or resin. The acid which is thus formed is denominated the suberic acid, and has been proved by the experiments of Lagrange to be an acid of a peculiar nature. It seems probable that cork exists in the bark of some other trees also, as well as the quercus suber. The bark of the ulmus suberosa assumes something of the external appearance of cork, which it resembles in its thickness, softness, and elasticity, and in its loose and porous texture, as well as also in its chemical properties. Fourcroy seems, indeed, to regard the epidermis of all trees whatever to be a sort of cork, but does not say on what grounds his opinion is founded.

1466. *Woody fibre.* The principal body of the root, stem, and branches of trees, is designated by the appellation of wood. But the term is too general for the purpose of analytical distinction, as the part designated by it often includes the greater part of the substances that have been already enumerated. It remains, therefore, to be ascertained whether there exists in the plant any individual substance different from those already described, and constituting more immediately the fabric of the wood. If a piece of wood is well dried and digested, first in water and then in alcohol, or such other solvent as shall produce no violent effects upon the insoluble parts; and if the digestion is continued till the liquid is no longer colored, and dissolves no more of the substance of the plant, there remains behind a sort of vegetable skeleton, which constitutes the basis of the wood, and which has been denominated woody fibre. It is composed of bundles of longitudinal threads, which are divisible into others still smaller. It is somewhat transparent. It is without taste and smell, and is not altered by exposure to the atmosphere. It is insoluble in water and alcohol; but the fixed alkalies decompose it with the assistance of heat. When heated in the open air it blackens without melting or frothing, and exhales a thick smoke and pungent odor, leaving a charcoal that retains the form of the original mass. When distilled in a retort it yields an empyreumatic oil, carburetted hydrogen gas, carbonic acid, and a portion of ammonia, according to Fourcroy, indicating the presence of nitrogen as constituting one of its elementary principles; and yet this ingredient does not appear in the result of the later analysis of Gay Lussac and Thenard, which is, carbon, 52.53; oxygen, 41.78; hydrogen, 5.69; total 100.

1467. *Charcoal.* When wood is burnt with a smothered flame, the volatile parts are driven off by the heat, and there remains behind a substance exhibiting the exact form, and even the several layers of the original mass. This process is denominated charring, and the substance obtained, charcoal. As it is the woody fibre alone which resists the action of heat, while the other parts of the plant are dissipated, it is plain that charcoal must be the residuum of woody fibre, and that the quantity of the one must depend upon the quantity of the other, if they are not rather to be considered as the same. Charcoal may be obtained from almost all parts of the plant, whether solid or fluid. It often escapes, however, during combustion, under the form of carbonic acid, of which it constitutes one of the elements. From a variety of experiments made on different plants and on their different parts, it appears that the green parts contain a greater proportion of charcoal than the rest. But this proportion is found to diminish in autumn, when the green parts begin to be deprived of their glutinous and extractive juice. The wood contains more charcoal than the albumen, the bark more than both. But this last result is not constant in all plants, because the bark is not a homogeneous substance, the outer parts being affected by the air and the inner parts not. The wood of the quercus robur, separated from the albumen, yielded from 100 parts of its dried substance 19.75 of charcoal; the albumen, 17.5; the bark, 26; leaves gathered in May, 80; in September, 26. But the quantity of charcoal differs also in different plants, as well as in different parts of the same. According to the experiments of Musset, 100 parts of the following trees afforded as follows:—

Lignum vitæ	26.8	Walnut	20.6	Norway fir	19.2
Mahogany	25.4	Holly	19.9	Sallow	18.4
Laburnum	24.5	Beech	19.9	Ash	17.9
Chestnut	23.2	American maple	19.9	Birch	17.4
Oak	22.6	Elm	19.5	Scotch pine	16.4
American black birch	21.4				

1468. *The properties of charcoal* are insolubility in water, of which, however, it absorbs a portion when newly made, as also of atmospheric air. It is incapable of putrefaction. It is not altered by the most violent heat that can be applied, if all air and moisture are excluded; but when heated to about 800 it burns in atmospheric air or oxygene gas, and if pure, without leaving any residuum. It is regarded by chemists as being a triple compound, of which the ingredients are carbon, hydrogen, and oxygene. Charcoal is of great utility both to the chemist and artist as a fuel for heating furnaces, as well as for a variety of other purposes. It is an excellent filter for purifying water. It is a very good tooth-powder; and is also an indispensable ingredient in the important manufacture of gunpowder.

1469. *The sap.* If the branch of a vine is cut asunder early in the spring, before the leaves have begun to expand, a clear and colorless fluid will issue from the wound, which gardeners denominate the tears of the vine. It is merely, however, the ascending sap, and may be procured from almost any other plant by the same or similar means, and at the same season; but particularly from the maple, birch, and walnut-tree, by means of boring a hole in the trunk. It issues chiefly from the porous and mixed tubes of the albumen; though sometimes it does not flow freely till the bore is carried to the centre. A small branch of a vine has been known to yield from twelve to sixteen ounces, in the space of twenty-four hours. A maple-tree of moderate size yields about 200 pints in a season, as has been already stated; and a birch-tree has been known to yield in the course of the bleeding-season, a quantity equal to its own weight. In the sap of fagus sylvatica, Vauquelin found the following ingredients:—Water, acetate of lime, with excess of acid, acetate of potass, gallic acid, tannin, mucous and extractive matter, and acetate of alumina. In 1039 parts of the sap of the ulmus campestris, he found 1027 parts of water and volatile matter, 9240 of acetate of potass, 1060 of vegetable matter, 0796 of carbonate of lime, besides some slight indications of the presence of sulphuric and muriatic acids; and at a later period of the season he found the vegetable matter increased, and the carbonate of lime and acetate of potass diminished. From the above experiments, therefore, as well as from those of other chemists, it is plain that the sap consists of a great variety of ingredients, differing in different species of plants; though there is too little known concerning it to warrant the deduction of any general conclusions, as the number of plants whose sap has been hither-

to analysed is yet but very limited. It is the grand and principal source of vegetable aliment, and may be regarded as being somewhat analogous to the blood of animals. It is not made use of by man, at least in its natural state. But there are trees, such as the birch, whose sap may be manufactured into a very pleasant wine; and it is well known that the sap of the American maple-tree yields a considerable quantity of sugar.

1470. *The proper juice.* When the sap has received its last degree of elaboration from the different organs through which it has to pass, it is converted into a peculiar fluid, called the proper juice. This fluid may be distinguished from the sap by means of its color, which is generally green, as in periwinkle; or red, as in logwood; or white, as in spurge; or yellow, as incelandine; from the two last of which it may readily be obtained by breaking the stem asunder, as it will then exude from the fracture. Its principal seat is in the bark, where it occupies the simple tubes; but sometimes it is situated between the bark and wood, as in the juniper-tree; or in the leaf, as in the greater part of herbs; or it is diffused throughout the whole plant, as in the fir and hemlock; in which case, either the proper juice mixes with the sap, or the vessels containing it have ramifications so fine as to be altogether imperceptible. It is not, however, the same in all plants, nor even in the different parts of the same plant. In the cherry-tree it is mucilaginous; in the pine it is resinous; in spurge andcelandine it is caustic, though resembling in appearance an emulsion. In many plants the proper juice of the bark is different from that of the flower; and the proper juice of the fruit different from both. Its appearance under the microscope, according to Sencbier, is that of an assemblage of small globules connected by small and prism-shaped substances placed between them. If this juice could be obtained in a state of purity, its analysis would throw a considerable degree of light upon the subject of vegetation. But it seems impracticable to extract it without a mixture of sap. Sencbier analysed the milky juice of euphorbia cyparissias, of which he had procured a small quantity considerably pure, though its pungency was so great as to occasion an inflammation of the eyes to the person employed to procure it. It mixed readily with water, to which it communicated its color. When left exposed to the air a slight precipitation ensued; and when allowed to evaporate a thin and opaque crust remained behind. Alcohol coagulated it into small globules. Ether dissolved it entirely, as did also oil of turpentine. Sulphuric acid changed its color to black; nitric acid to green. The most accurate experiments on the subject are those of Chaptal. When oxymuriatic acid was poured into the peculiar juice of euphorbia, a very copious white precipitate fell down, which, when washed and dried, had the appearance of starch, and was not altered by keeping. Alcohol, aided by heat, dissolved two thirds of it, which the addition of water again precipitated. They had all the properties of resin. The remaining third part possessed the properties of woody fibre. The same experiment was tried on the juice of a variety of other plants, and the result uniformly was that oxymuriatic acid precipitated from them woody fibre.

1471. *The virtues of plants have generally been thought to reside in their proper juices,* and the opinion seems indeed to be well founded. It is at least proved by experiment in the poppy, spurge, and fig. The juice of the first is narcotic, of the two last corrosive. The diuretic and balsamic virtues of the fir reside in its turpentine, and the purgative property of jalap in its resin. If sugar is obtained from the sap of the sugar-cane and maple, it is only because it has been mixed with a quantity of proper juice. The bark certainly contains it in greatest abundance, as may be exemplified in cinnamon and quinquina. But the peach-tree furnishes an exception to this rule: its flowers are purgative, and the whole plant aromatic; but its gum is without any distinguished virtues. Malpighi regarded the proper juice as the principle of nourishment, and compared it to the blood of animals; but this analogy does not hold very closely. The sap is, perhaps, more analogous to the blood, from which the proper juice is rather a secretion. In one respect, however, the analogy holds good, that is, with regard to extravasated blood and peculiar juices. If the blood escapes from the vessels it forms neither flesh nor bones, but tumors; and if the proper juices escape from the vessels containing them, they form neither wood nor bark, but a lump or deposit of inspissated fluid. To the sap or to the proper juice, or rather to a mixture of both, we must refer such substances as are obtained from plants under the name of expressed juices, because it is evident that they can come from no other source. In this state they are generally obtained in the first instance whether with a view to their use in medicine or their application to the arts. It is the business of the chemist or artist to separate and purify them afterwards according to the peculiar object he may happen to have in view, and the use to which he purposes to apply them. They contain, like the sap, acetate of potash or of lime, and assume a deeper shade of color when exposed to the fire or air. The oxymuriatic acid precipitates from them a colored and flaky substance as from the sap, and they yield by evaporation a quantity of extract. But they differ from the sap in exhibiting no traces of tannin or gallic acid, and but rarely of the saccharine principle.

1472. *Ashes.* When vegetables are burnt in the open air the greatest part of their substance is evaporated during the process of combustion; but ultimately there remains behind, a portion which is altogether incombustible, and incapable of being volatilised by the action of fire. This residuum is known by the name of ashes. Herbaceous plants, after being dried, yield more ashes than woody plants; the leaves more than the branches; and the branches more than the trunk. The albumum yields also more ashes than the wood; and putrid vegetables yield more ashes than the same vegetables in a fresh state, if the putrefaction has not taken place in a current of water. The result of Saussure's experiments on 1000 parts of different plants was as follows:—

<i>Gathered in May,</i>	dried leaves of the oak	- - - -	55	<i>parts of ashes.</i>
	green leaves of the oak	- - - -	13	
	dried leaves of the rhododendron	- - - -	50	
	dried leaves of the <i>ascalus hippocastanum</i>	- - - -	72	
	trunk and branches of <i>ascalus hippocastanum</i>	- - - -	35	
<i>Gathered in September,</i>	dried leaves of the <i>ascalus hippocastanum</i>	- - - -	86	
	dried leaves of the oak	- - - -	55	
	green leaves of the oak	- - - -	24	
<i>Gathered when in flower,</i>	leaves of <i>pisum sativum</i>	- - - -	95	
<i>Gathered when in fruit,</i>	leaves of <i>pisum sativum</i>	- - - -	81	
	leaves of <i>vicia juba</i>	- - - -	16	
<i>Gathered before coming into flower,</i>	leaves of the <i>vicia faba</i>	- - - -	16	
<i>Oak, the dried bark 60,</i>	the albumum 4, wood	- - - -	2	

1473. *The analysis of the ashes of plants,* with a view to the discovery of the ingredients of which they are composed, produces alkalis, earths, and metals, which must therefore be considered as ingredients in the composition of the vegetable. But vegetable ashes contain also a variety of other principles, occurring, however, in such small proportions as generally to escape observation. Perhaps they contain all substances not capable of being volatilised by the action of fire.

1474. *Alkalies.* The alkalies are a peculiar class of substances, distinguished by a caustic taste and the property of changing vegetable blues to green. They are generally regarded as being three in number, potash, soda, and ammonia, of which the two former only are found in the ashes of vegetables. Ammonia is, indeed, often obtained from vegetable substances by means of distillation, but then it is always formed during the process. If the ashes of land vegetables, burnt in the open air, are repeatedly washed in water, and the water filtered and evaporated to dryness, potash is left behind. The potash of commerce is manufactured in this manner, though it is not quite pure. But it may be purified by dissolving it in spirits of wine, and evaporating the solution to dryness in a silver vessel. When pure it is white and semi-transparent, and is extremely caustic and deliquescent. It dissolves all soft animal substances, and changes vegetable blues into green. It dissolves alumina, and also a small quantity of siliceous matter, with which it fuses into glass by the aid of fire. It had been long suspected by chemists to be a compound substance; and according to the notable discovery by Sir H. Davy, its component parts are at last ascertained to be a

highly inflammable metal, which he denominates potassium, and oxygen — one proportion of each. Soda is found chiefly in marine plants, from the ashes of which it is obtained by means of lixiviation. It exists in great abundance in *salsola* soda, *zostera maritima*, and in various species of fuci. It is generally obtained in the state of a carbonate, but is purified in the same manner as potass, to which it is similar in its properties; but from which it is easily distinguished by its forming a hard soap with oil, while potass forms a soft soap. It consists, according to Sir H. Davy, of one proportion of a metal which he denominates sodium, and two proportions of oxygen. Such are the only vegetable alkalies, and modes of obtaining them. They are found generally in the state of carbonates, sulphates, or muriates, salts that form beyond all comparison the most abundant ingredient in the ashes of green herbaceous plants whose parts are in a state of vegetation. The ashes of the golden rod, growing in an uncultivated soil, and of the bean, turn-sol, and wheat, were found by Saussure to contain at least three fourths of their weight of alkaline salts. This was nearly the case also with the leaves of trees just bursting from the bud. But the proportion of alkaline salts is found to diminish rather than to augment as the parts of the plant are developed. The ashes of the leaves of the oak, gathered in May, yielded 47 parts in the 100 of alkaline salts; and in September, only 17.

1475. *The utility of the alkalies*, as obtained from vegetables, is of the utmost importance in the arts, particularly in the formation of glass and of soaps. If a mixture of soda or potass, and siliceous sand, in certain proportions, is exposed to a violent heat, the ingredients are melted down into a fluid mass, which is glass in a state of fusion. In this state it may be moulded into almost any form at the pleasure of the artist. And accordingly we find that it is manufactured into a great variety of utensils and instruments, under the heads of flint-glass, crown-glass, bottle-glass. Bottle-glass is the coarsest; it is formed of soda and common sand, and is used in the manufacture of the coarser sort of bottles. Crown-glass is composed of soda and fine sand: it is moulded into large plates for the purpose of forming window-glasses and looking-glasses. Flint-glass is the finest and most transparent of all: that which is of the best quality is composed of 120 parts of white siliceous sand, 40 parts of pearl-ash, 35 of red oxide of lead, 13 of nitrate of potass, and 25 of black oxide of manganese. It is known also by the name of crystal, and may be cut and polished so as to serve for a variety of ornamental purposes, as well as for the more important and more useful purposes of forming optical instruments, of which the discoveries of the telescope and the microscope are the curious or sublime results. If a quantity of oil is mixed with half its weight of a strong solution of soda or potass, a combination takes place which is rendered more complete by means of boiling. The new compound is soap. The union of oil with potass forms soft soap, and with soda hard soap; substances of the greatest efficacy as detergents, and of the greatest utility in the washing and bleaching of linen. The alkalies are used also in medicine, and found to be peculiarly efficacious in the reduction of urinary calculi.

1476. *Earths*. The only earths which have hitherto been found in plants are the following: lime, silica, magnesia, alumina.

1477. *Lime* is by far the most abundant earth. It is generally combined with a portion of phosphoric, carbonic, or sulphuric acid, forming phosphates, or carbonates, or sulphates of lime. The phosphate of lime is, next to the alkaline salt, the most abundant ingredient in the ashes of green herbaceous plants, whose parts are all in a state of vegetation. The leaf of a tree, bursting from the bud, contains in its ashes a greater proportion of earthy phosphate than at any other period: 100 parts of the ashes of the leaves of the oak, gathered in May, furnished 24 parts of earthy phosphate; in September, only 18.25. In annual plants the proportion of earthy phosphate diminishes from the period of their germination to that of their flowering. Plants of the bean, before flowering, gave 14.5 parts of earthy phosphate; in flower, only 13.5. Carbonate of lime is, next to phosphate of lime, the most abundant of the earthy salts that are found in vegetables. But if the leaves of plants are washed in water the proportion of carbonate is augmented. This is owing to the subtraction of their alkaline salts and phosphates in a greater proportion than their lime. In green herbaceous plants, whose parts are in a state of increase, there is but little carbonate of lime; but the ashes of the bark of trees contain an enormous quantity of carbonate of lime, and much more than the albumen, as do also the ashes of the wood. The ashes of most seeds contain no carbonate of lime; but they abound in phosphate of potass. Hence the ashes of plants, at the period of the maturity of the fruit, yield less carbonate of lime than at any previous period.

1478. *Silica* is not found to exist in a great proportion in the ashes of vegetables, unless they have been previously deprived of their salts and phosphates by washing; but when the plants are washed in water, the proportion of their silica augments. The ashes of the leaves of the hazel, gathered in May, yielded 2.5 parts of silica in 100. The same leaves, washed, yielded four parts in 100. Young plants, and leaves bursting from the bud, contain but little of silica in their ashes; but the proportion of silica augments as the parts are developed. But perhaps this is owing to the diminution of the alkaline salts. The ashes of some stalks of wheat gathered a month before the time of flowering, and having some of the radicle leaves withered, contained 12 parts of silica and 65 of alkaline salts in 100. At the period of their flowering, and when more of their leaves were withered, the ashes contained 32 parts of silica and 54 of alkaline salts. Seeds divested of their external covering, contain less silica than the stem furnished with its leaves; and it is somewhat remarkable that there are trees of which the bark, albumen, and wood, contain scarcely any silica, and the leaves a great deal, particularly in autumn. This is a phenomenon that seems inexplicable. The greater part of the grasses contain a very considerable proportion of silica, as do also the plants of the genus *quisetum*. Sir H. Davy has discovered that it forms a part of the epidermis of these plants, and in some of them the principal part. From 100 parts of the epidermis of the following plants the proportions of silica were, in bonnet cane, 90; bamboo, 71.4; common reed, 48.1; stalks of corn, 66.5. Owing to the silica contained in the epidermis, the plants in which it is found, are sometimes used to give a polish to the surface of substances where smoothness is required. The Dutch rush, *quisetum hyemale*, a plant of this kind, is used to polish even brass.

1479. *Magnesia* does not exist so abundantly in the vegetable kingdom as the two preceding earths. It has been found, however, in several of the marine plants, particularly the fuci; but *salsola* soda contains more of magnesia than any other plant yet examined. According to Vauquelin, 100 parts of it contain 17.925 of magnesia.

1480. *Alumina* has been detected in several plants, but never except in very small quantities.

1481. *Metallic oxides*. Among the substances found in the ashes of vegetables, we must class also metals. They occur, however, only in small quantities, and are not to be detected except by the most delicate experiments. The metals hitherto discovered in plants are iron, manganese, and perhaps gold. Of these iron is by far the most common. It occurs in the state of an oxide, and the ashes of hard and woody plants, such as the oak, are said to contain nearly one twelfth of their own weight of this oxide. The ashes of *salsola* contain also a considerable quantity. The oxide of manganese was first detected in the ashes of vegetables by Scheele, and afterwards found by Proust in the ashes of the pine, calendula, vine, green oak, and fig-tree. Becher, Kunkel, and Sage, together with some other chemists, contend also for the existence of gold in the ashes of certain plants; but the very minute portion which they found, seems more likely to have proceeded from the lead employed in the process than from the ashes of the plant. It has been observed by Saussure, that the proportion of the oxides of iron and of manganese augments in the ashes of plants as their vegetation advances. The leaves of trees furnish more of these principles in autumn than in spring. It is so also with annual plants. Seeds contain metals in less abundance than the stem; and if plants are washed in water, the proportions of their metallic oxides is augmented.

1482. *Such are the principal ingredients* that enter into the vegetable composition. They are indeed numerous, though some of them, such as the metallic oxides, occur in such small proportions as to render

it doubtful whether they are in reality vegetable productions or no. The same thing may be said of some of the other ingredients that have been found in the ashes of plants, which it is probable they have absorbed ready formed by the root, and deposited unaltered, so that they can scarcely be at all regarded as being the genuine products of vegetation.

1483. *Other substances.* Besides the substances above enumerated, there are also several others that have been supposed to constitute distinct and peculiar genera of vegetable productions, and which might have been introduced under such a character; such as the mucus, jelly, sarcocol, asparagin, inulin, and ulmin, of Dr. Thomson, as described in his well known *System of Chemistry*; but as there seems to be some difference of opinion among chemists with regard to them, and a belief entertained that they are but varieties of one or other of the foregoing ingredients, it is sufficient for the purposes of this work to have merely mentioned their names. Several other substances of a distinct and peculiar character have been suspected to exist in vegetable productions: such as the febrifuge principle of Seguin, as discovering itself in Peruvian bark; the principle of causticity or acidity of Senebier, as discovering itself in the roots of ranunculus bulbosus, scilla maritima, bryonia alba, and arum maculatum, in the leaves of digitalis purpurea, in the bark of daphne mezereum, and in the juice of the sparges, to which may be added the fluid secreted from the sting of the common nettle, the poisons inherent in some plants, and the medical virtues inherent in others; together with such peculiar principles as may be presumed to exist in such regions of the vegetable kingdom as remain yet unexplored. The important discoveries which have already resulted from the chemical analysis of vegetable substances encourage the hope that further discoveries will be the result of further experiment; and from the zeal and ability of such chemists as are now directing their attention to the subject, every thing is to be expected.

## SECT. II. *Simple Products.*

1484. *A very few constituent and uncompound elements* include all the compound ingredients of vegetables. The most essential of such compounds consist of carbon, oxygen, and hydrogen; a small proportion of nitrogen is said to be found only in cruciform plants. The remaining elementary principles which plants have been found to contain, although they may be necessary in the vegetable economy, yet they are by no means principles of the first importance, as occurring only in small proportions, and being dependent in a great measure on soil and situation; whereas the elements of carbon, oxygen, and hydrogen, form as it were the very essence of the vegetable subject, and constitute by their modifications the peculiar character of the properties of the plant. This is conspicuously exemplified in the result of the investigations of Gay Lussac, and Thenard, who have deduced from a series of the most minute and delicate experiments the three following propositions, which they have dignified by the name of Laws of Vegetable Nature (*Traité de Chem. Element.* tom. iii. chap. iii.): — 1st, Vegetable substances are always acid when the oxygen they contain is to the hydrogen in a greater proportion than in water; 2dly, Vegetable substances are always resinous, or oily, or spirituous, when the oxygen they contain is to the hydrogen in a smaller proportion than in water; 3dly, Vegetable substances are neither acid nor resinous, but saccharine, or mucilaginous, or analogous to woody fibre or starch, when the oxygen and hydrogen they contain are in the same proportion as in water. (See *Dr. Thomson's System of Chemistry.*)

## CHAP. IV.

### *Functions of Vegetables.*

1485. *The life, growth, and propagation of plants* necessarily involves the several following topics: germination, nutriment, digestion, growth and development of parts, anomalies of vegetable development, sexuality of vegetables, impregnation of the vegetable germen, changes consequent upon impregnation, propagation and dispersion of the species, causes limiting the dispersion of the species, evidence and character of vegetable vitality.

### SECT. I. *Germination of the Seed.*

1486. *Germination* is that act or operation of the vegetative principle by which the embryo is extricated from its envelopes, and converted into a plant. This is universally the first part of the process of vegetation. For it may be regarded as an indubitable fact, that all plants spring originally from seed. The conditions necessary to germination relate either to the internal state of the seed itself, or to the circumstances in which it is placed, with regard to surrounding substances.

1487. *The first condition necessary to germination* is, that the seed must have reached maturity. Unripe seeds seldom germinate, because their parts are not yet prepared to form their chemical combinations on which germination depends. There are some seeds, however, whose germination is said to commence in the very seed-vessel, even before the fruit is ripe, and while it is yet attached to the parent plant. Such are those of the tanglekolly of Adanson, and agave vivipara of East Florida, as well as of the cymus nelumbo of Sir J. E. Smith, or sacred bean of India; to which may be added the seeds of the common garden-radish, pea, lemon, &c. But these are examples of rare occurrence; though it is sometimes necessary to sow or plant the seed almost as soon as it is fully ripe, as in the case of the coffee-bean; which will not germinate unless it is sown within five or six weeks after it has been gathered. But most seeds, if guarded from external injury, will retain their germinating faculty for a period of many years. This has been proved by the experiment of sowing seeds that have been long so kept; as well as by the deep ploughing up of fields that have been long left without cultivation. A field that was thus ploughed up near Dunkeld, in Scotland, after a period of forty years' rest, yielded a considerable blade of

black oats without sowing. It could have been only by the plough's bringing up to the surface, seeds that had been formerly too deeply lodged for germination.

1488. *The second condition* is, that the seeds sown must be *defended from the action of the rays of light*. This has no doubt been long known to be a necessary condition of germination, if we regard the practice of the harrowing or raking in of the grains or seeds sown by the farmer or gardener as being founded upon it.

1489. *A third condition* necessary to germination is the *access of heat*. No seed has ever been known to germinate at or below the freezing point. Hence seeds do not germinate in winter, even though lodged in their proper soil. But the vital principle is not necessarily destroyed in consequence of this exposure; for the seed will germinate still, on the return of spring, when the ground has been again thawed, and the temperature raised to the proper degree. But this degree varies considerably in different species of seeds, as is obvious from observing the times of their germination, whether in the same or in different climates. For if seeds which naturally sow themselves, germinate in different climates at the same period, or in the same climate at different periods, the temperature necessary to their germination must of consequence be different. Now these cases are constantly occurring and presenting themselves to our notice; and have also been made the subject of particular observation. Adanson found that seeds which will germinate in the space of twelve hours in an ordinary degree of heat may be made to germinate in the space of three hours by exposing them to a greater degree of heat; and that seeds transported from the climate of Paris to that of Senegal, have their periods of germination accelerated from one to three days. (*Familles des Plantes*, vol. i. p. 84.) Upon the same principle, seeds transported from a warmer to a colder climate, have their periods of germination protracted till the temperature of the latter is raised to that of the former. This is well exemplified in the case of green-house and hot-house plants, from which it is also obvious that the temperature must not be raised beyond a certain degree, otherwise the vital principle is totally destroyed.

1490. *A fourth condition* necessary to germination is the *access of moisture*. Seeds will not germinate if they are kept perfectly dry. Water, therefore, or some liquid equivalent to it, is essential to germination. Hence rain is always acceptable to the farmer or gardener, immediately after he has sown his seeds; and if no rain falls, recourse must be had, if possible, to artificial watering. But the quantity of water applied is not a matter of indifference. There may be too little, or there may be too much. If there is too little, the seed dies for want of moisture; if there is too much, it then rots. The case is not the same, however, with all seeds. Some can bear but little moisture, though others will germinate even when partially immersed; as was proved by an experiment of Du Hamel's, at least in the case of pease, which he placed merely upon a piece of wet sponge, so as to immerse them by nearly the one-half, and which germinated as if placed in the soil. But this was found to be the most they could bear; for when totally immersed in the water they rotted. There are some seeds, however, that will germinate even when wholly submersed. The seeds of aquatics must of necessity germinate under water; and pease have been also known to do so under certain conditions.

1491. *A fifth condition* necessary to germination is the *access of atmospheric air*. Seeds will not germinate if placed in a *vacuum*. Ray introduced some grains of lettuce-seed into the receiver of an air-pump, which he then exhausted. The seeds did not germinate. But they germinated upon the re-admission of the air, which is thus proved by consequence to be necessary to their germination. Achard proved that no seed will germinate in nitrogenous gas, or carbonic acid gas, or hydrogenous gas, except when mixed with a certain proportion of oxygenous gas; and hence concluded that oxygenous gas is necessary to the germination of all seeds, and the only constituent part of the atmospheric air which is absolutely necessary. Humboldt found that the process of germination is accelerated by means of previously steeping the seed in water impregnated with oxyuriatic acid. Cress-seed treated in this manner germinated in the space of three hours, though its ordinary period of germination is not less than thirty-two hours.

1492. *The period necessary to complete the process of germination* is not the same in all seeds, even when all the necessary conditions have been furnished. Some species require a shorter, and others a longer period. The grasses are among the number of those plants whose seeds are of the most rapid germination; then perhaps cruciform plants; then leguminous plants; then labiate plants; then umbelliferous plants; and in the last order rosaceous plants, whose seeds germinate the slowest. The following table indicates the periods of the germination of a considerable variety of seeds, as observed by Adanson:—

	Days.		Days.		Days.
Wheat, Millet-seed	1	Radish, Beet-root	6	Hyssop	30
Spinage, Beans, Mustard	3	Barley	7	Par-ley	40 or 50
Lettuce, Aniseed	4	Orache	8	Almond, Chestnut, Peach	1 year
Melon, Cucumber, Cress-seed	5	Purslain	9	Rose, Hawthorn, Filbert	2 years.
		Cabbage	10		

1493. *Physical phenomena*. When a seed is committed to the soil under the conditions that have been just specified, the first infallible symptom of germination is to be deduced

from the prolongation of the radicle (*fig. 230 a.*), bursting through its proper integuments, and directing its extremity downwards into the soil. The next step in the process of germination is the evolution of the cotyledon or cotyledons (*c*), unless the seed is altogether acotyledonous, or the cotyledons hypogean, as in the oak (*b*). The next step, in the case of seeds furnished with cotyledons, is that of the extrication of the plumet (*c*), or first real leaf, from within or from between the cotyledon or cotyledons, and its expansion in the open air. The last and concluding step is the development of the rudiments of a stem (*d*), if the species is furnished with a stem, and the plant is complete. Whatever way the seed may be deposited, the invincible tendency of the radicle is to descend and fix itself in the earth; and of the plumet to ascend into the air. Many conjectures have been offered to account for this. Knight accounts for it on the old but revived principle of gravitation. Keith conjectures that it takes place from a power

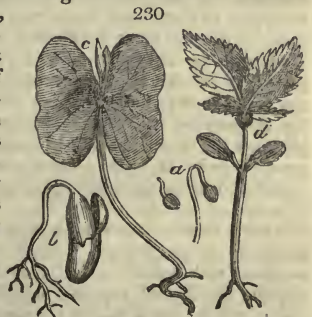

inherent in the vegetable subject, analogous to what we call instinct in the animal subject, infallibly directing it to the situation best suited to the acquisition of nutriment and consequent development of its parts.

1494. *The chemical phenomena* of germination consist chiefly in the changes that are effected in the nutriment destined for the support and development of the embryo till it is converted into a plant. This nutriment either passes through the cotyledons, or is contained in them; because the embryo dies when they are prematurely cut off. But the farinaceous substance of the cotyledons, at least in exalbuminous seeds, is a proof that they themselves contain the nutriment. They are to be regarded, therefore, as repositories of the food destined for the support of the embryo in its germinating state. And if the seed is furnished with a distinct and separate albumen, then is the albumen to be regarded as the repository of food, and the cotyledon or cotyledons as its channel of conveyance. But the food thus contained in the albumen or cotyledons is not yet fitted for the immediate nourishment of the embryo. Some previous preparation is necessary; some change must be effected in its properties. And this change is effected by the intervention of chemical agency. The moisture imbibed by a seed placed in the earth is immediately absorbed by the cotyledons or albumen, which it readily penetrates, and on which it immediately begins to operate a chemical change, dissolving part of their farina, or mixing with their oily particles, and forming a sort of emulsive juice. The consequence of this change is a slight degree of fermentation, induced, perhaps, by the mixture of the starch and gluten of the cotyledons in the water which they have absorbed, and indicated by the extraction of a quantity of carbonic acid gas, as well as by the smell and taste of the seed. This is the commencement of the process of germination, which takes place even though no oxygene gas is present. But if no oxygene gas is present, then the process stops; which shows that the agency of oxygene gas is indispensable to germination. Accordingly, when oxygene gas is present it is gradually inhaled by the seed; and the farina of the cotyledons is found to have changed its savor. Sometimes it becomes acid, but generally sweet, resembling the taste of sugar; and is consequently converted into sugar or some substance analogous to it. This is a further proof that a degree of fermentation has been induced; because the result is precisely the same in the process of the fermentation of barley when converted into malt, as known by the name of the saccharine fermentation; in which oxygene gas is absorbed, heat and carbonic acid evolved, and a tendency to germination indicated by the shooting of the radicle. The effect of oxygen, therefore, in the process, is that of converting the farina of the albumen or cotyledons into a mild and saccharine food, fit for the nourishment of the infant plant by diminishing the proportion of its carbon, and in augmenting, by consequence, that of its oxygen and hydrogen. The radicle gives the first indications of life, expanding and bursting its integuments, and at length fixing itself in the soil: the plumule next unfolds its parts, developing the rudiments of leaf, branch, and trunk: and, finally, the seminal leaves decay and drop off; and the embryo has been converted into a plant, capable of abstracting immediately from the soil or atmosphere the nourishment necessary to its future growth.

#### SECT. II. *Food of the vegetating Plant.*

1495. *The substances which plants abstract from the soil or atmosphere*, or the food of the vegetating plant, have long occupied the phytological enquirer. What then are the component principles of the soil and atmosphere? The investigations and discoveries of modern chemists have done much to elucidate this dark and intricate subject. Soil, in general, may be regarded as consisting of earths, water, vegetable mould, decayed animal substances, salts, ores, alkalies, gases, perhaps in a proportion corresponding to the order in which they are now enumerated; which is at any rate the fact with regard to the three first, though their relative proportions are by no means uniform. The atmosphere has been also found to consist of at least four species of elastic matter — nitrogen, oxygen, carbonic acid gas, and vapor; together with a multitude of minute particles detached from the solid bodies occupying the surface of the earth, and wafted upon the winds. The two former ingredients exist in the proportion of about four to one; carbonic acid gas in the proportion of about one part in 100; and vapor in proportion still less. Such then are the component principles of the soil and atmosphere, and sources of vegetable nourishment. But the whole of the ingredients of the soil and atmosphere are not taken up indiscriminately by the plant and converted into vegetable food, because plants do not thrive indiscriminately in all varieties of soil. Part only of the ingredients are selected, and in certain proportions: as is evident from the analysis of the vegetable substance given in the foregoing chapter, in which it was found that carbon, hydrogen, oxygen, and nitrogen, are the principal ingredients of plants; while the other ingredients contained in them occur but in very small proportions. It does not however follow, that these ingredients enter the plant in an uncombined and insulated state, because they do not always so exist in the soil and atmosphere; it follows only that they are inhaled or absorbed by the vegetating plant under one modification or another. The plant then does not select such principles as are the most abundant in the soil and atmosphere; nor in the proportions in which they exist; nor in an uncombined and insulated state. But what are the substances actually selected; in what state are they taken up; and in what proportions? In order to give arrangement and elucidation to the subject, it shall be considered under the following heads: Water, Gases, Vegetable Extracts, Salts, Earths, Manures.

1496. *Water.* As water is necessary to the commencement of vegetation, so also is it necessary to its progress. Plants will not continue to vegetate unless their roots are supplied with water; and if they are kept long without it, the leaves will droop and become flaccid, and assume a withered appearance. Now this is evidently owing to the loss of water; for if the roots are again well supplied with water, the weight of the plant is increased, and its freshness restored. But many plants will grow, and thrive, and effect the development of all their parts, if the root is merely immersed in water, though not fixed in the soil. Tulips, hyacinths, and a variety of plants with bulbous



roots, may be so reared, and are often to be met with so vegetating; and many plants will also vegetate though wholly immersed. Most of the marine plants are of this description. It can scarcely be doubted, therefore, that water serves for the purpose of a vegetable aliment. But if plants cannot be made to vegetate without water; and if they will vegetate, some when partly immersed without the assistance of soil; and some even when totally immersed, so as that no other food seems to have access to them; does it not follow that water is the sole food of plants, the soil being merely the basis on which they rest, and the receptacle of their food? This opinion has had many advocates; and the arguments and experiments adduced in support of it were, at one time, thought to have completely established its truth. It was indeed the prevailing opinion of the seventeenth century, and was embraced by several philosophers even of the eighteenth century; but its ablest and most zealous advocates were Van Helmont, Boyle, Du Hamel, and Bonnet, who contended that water, by virtue of the vital energy of the plant, was sufficient to form all the different substances contained in vegetables. Du Hamel reared in the above manner plants of the horse-chestnut and almond to some considerable size, and an oak till it was eight years old. And, though he informs us that they died at last only from neglect of watering: yet it seems extremely doubtful whether they would have continued to vegetate much longer, even if they had been watered ever so regularly; for he admits, in the first place, that they made less and less progress every year; and, in the second place, that their roots were found to be in a very bad state. The result of a great variety of experiments is, that water is not the sole food of plants, and is not convertible into the whole of the ingredients of the vegetable substance, even with the aid of the vital energy; though plants vegetating merely in water, do yet augment the quantity of their carbon.

1497. *Gases.* When it was found that water is insufficient to constitute the sole food of plants, recourse was next had to the assistance of the atmospheric air; and it was believed that the vital energy of the plant, is at least capable of furnishing all the different ingredients of the vegetable substance, by means of decomposing and combining, in different ways, atmospheric air and water. But as this extravagant conjecture is founded on no proof, it is consequently of no value. It must be confessed, however, that atmospheric air is indispensably necessary to the health and vigor of the plant, as may be seen by looking at the different aspects of plants exposed to a free circulation of air, and plants deprived of it: the former are vigorous and luxuriant; the latter weak and stunted. It may be seen also by means of experiment even upon a small scale. If a plant is placed under a glass to which no new supply of air has access, it soon begins to languish, and at length withers and dies; but particularly if it is placed under the exhausted receiver of an air-pump; as might indeed be expected from the failure of the germination of the seed in similar circumstances. The result of experiments on this subject is, that atmospheric air and water are not the only principles constituting the food of plants. But as in germination, so also in the progress of vegetation, it is part only of the component principles of the atmospheric air that are adapted to the purposes of vegetable nutrition, and selected by the plant as a food. Let us take them in the order of their reversed proportions.

1498. *The effect of the application of carbonic acid gas* was found to be altogether prejudicial in the process of the germination of the seed. But in the process of subsequent vegetation its application has been found, on the contrary, to be extremely beneficial. Plants will not indeed vegetate in an atmosphere of pure carbonic acid, as was first ascertained by Dr. Priestley, who found that sprigs of mint growing in water, and placed over wort in a state of fermentation, generally became quite dead in the space of a day, and did not even recover when put into an atmosphere of common air. Of a number of experiments the results are—1st, That carbonic acid gas is of great utility to the growth of plants vegetating in the sun, as applied to the leaves and branches; and whatever increases the proportion of this gas in their atmosphere, at least within a given degree, forwards vegetation; 2d, That, as applied to the leaves and branches of plants, it is prejudicial to their vegetation in the shade, if administered in a proportion beyond that in which it exists in atmospheric air; 3d, That carbonic acid gas, as applied to the roots of plants, is also beneficial to their growth, at least in the more advanced stages of vegetation.

1499. As *oxygen* is essential to the commencement and progress of germination, so also it is essential to the progress of vegetation. It is obvious, then, that the experiment proves that it is beneficial to the growth of the vegetable as applied to the root; necessary to the development of the leaves; and to the development of the flower and fruit. The flower-bud will not expand if confined in an atmosphere deprived of oxygen, nor will the fruit ripen. Flower-buds confined in an atmosphere of pure nitrogen faded without expanding. A bunch of unripe grapes introduced into a globe of glass which was luted by its orifice to the bough, and exposed to the sun, ripened without effecting any material alteration in its atmosphere. But when a bunch was placed in the same circumstances, with the addition of a quantity of lime, the atmosphere was contaminated, and the grapes did not ripen. Oxygen, therefore, is essential to the development of the vegetating plant, and is inhaled during the night.

1500. Though *nitrogen gas* constitutes by far the greater part of the mass of atmospheric air, it does not seem capable of affording nutriment to plants; for as seeds will not germinate, so neither will plants vegetate in it, but for a very limited time, such as the vinca minor, lythrum salicaria, inula dysenterica, epilobium hirsutum, and polygonum persicaria, that seem to succeed equally well in an atmosphere of nitrogen gas as in an atmosphere of common air. Nitrogen is found in almost all vegetables, particularly in the wood, in extract, and in their green parts, derived, no doubt, from the extractive principle of vegetable mould.

1501. *Hydrogene gas.* A plant of the epilobium hirsutum, which was confined by Priestley in a receiver filled with inflammable air or hydrogen, consumed one third of its atmosphere and was still green. Hence Priestley inferred, that it serves as a vegetable food, and constitutes even the true and proper pabulum of the plant. But the experiments of later phytologists do not at all countenance this opinion.

Our conclusion from various experiments is, that hydrogen is unfavorable to vegetation, and does not serve as the food of plants. But hydrogen is contained in plants as is evident from their analysis; and if they refuse it when presented to them in a gaseous state, in what state do they then acquire it? To this question it is sufficient for the present to reply, that if plants do not acquire their hydrogen in the state of gas, they may at least acquire it in the state of water, which is indisputably a vegetable food, and of which hydrogen constitutes one of the component parts.

1502. *Vegetable extract.* When it was found that atmospheric air and water are not, even conjointly, capable of furnishing the whole of the aliment necessary to the development of the plant, it was then alleged that, with the exception of water, all substances constituting a vegetable food must at least be administered to the plant in a gaseous state. But this also is a conjecture unsupported by proof; for even with regard to such plants as grow upon a barren rock, or in pure sand, it cannot be said that they receive no nourishment whatever besides water, except in a gaseous state. Many of the particles of decayed animal and vegetable substances, which float in the atmosphere and attach themselves to the leaves, must be supposed to enter the plant in solution with the moisture which the leaves imbibe; and so also similar substances contained in the soil must be supposed to enter it by the root: but these substances may certainly contain vegetable nourishment; and they will perhaps be found to be taken up by the plant in proportion to their degree of solubility in water, and to the quantity in which they exist in the soil. Now one of the most important of these substances is vegetable extract. When plants have attained to the maturity of their species, the principles of decay begin gradually to operate upon them, till they at length die and are converted into dust or vegetable mould, which, as might be expected, constitutes a considerable proportion of the soil. The chance then is, that it is again converted into vegetable nourishment, and again enters the plant. But it cannot wholly enter the plant, because it is not wholly soluble in water. Part of it, however, is soluble, and consequently capable of being absorbed by the root, and that is the substance which has been denominated extract.

1503. *Saussure* filled a large vessel with pure mould of turf, and moistened it with distilled or rain water, till it was saturated. At the end of five days, when it was subjected to the action of the press, 10,000 parts in weight of the expressed and filtered fluid yielded, by evaporation to dryness, 26 parts of extract. In a similar experiment upon the mould of a kitchen-garden which had been manured with dung, 10,000 parts of a fluid yielded 10 of extract. And in a similar experiment upon mould taken from a well-cultivated corn-field, 10,000 parts of fluid yielded four parts of extract. Such was the result in these particular cases. But the quantity of extract that may be separated from the common soil is not in general very considerable. After twelve decoctions, all that could be separated was about one eleventh of its weight; and yet this seems to be more than sufficient for the purposes of vegetation: for a soil containing this quantity was found by experiment to be less fertile, at least for peas and beans, than a soil that contained only one half or two thirds the quantity. But if the quantity of extract must not be too much, neither must it be too little. Plants that were put to vegetate in soil deprived of its extract, as far as repeated decoctions could deprive it, were found to be much less vigorous and luxuriant than plants vegetating in soil not deprived of its extract; and yet the only perceptible difference between them is, that the former can imbibe and retain a much greater quantity of water than the latter. From this last experiment, as well as from the great proportion in which it exists in the living plant, it evidently follows that extract constitutes a vegetable food. But extract contains nitrogen; for it yields by distillation a fluid impregnated with ammonia. The difficulty, therefore, of accounting for the introduction of nitrogen into the vegetating plant, as well as for its existence in the mature vegetable substance, is done away; for, although the plant refuses it when presented in a gaseous state, it is plain that it must admit it along with the extract. It seems also probable that a small quantity of carbonic acid gas enters the plant along with the extractive principle, as it is known to contain this gas also.

1504. *Salts*, in a certain proportion, are found in most plants, such as nitrate, muriate, and sulphate of potass or soda, as has been already shown. These salts are known to exist in the soil, and the root is supposed to absorb them in solution with the water by which the plant is nourished. It is at least certain that plants may be made to take up by the roots a considerable proportion of salts in a state of artificial solution. But if salts are thus taken up by the root of the vegetating plant, does it appear that they are taken up as a food? Some plants, it must be confessed, are injured by the application of salts, as is evident from the experiments of *Saussure*; but others are as evidently benefited by it. Trefoil and lucerne have their growth much accelerated by the application of sulphate of lime, though many other plants are not at all influenced by its action. The parietaria, nettle, and borage will not thrive, except in such soils as contain nitrate of lime, or nitrate of potass; and plants inhabiting the sea-coast, as was observed by *Du Hamel*, will not thrive in a soil that does not contain muriate of soda. It has been thought, however, that the salts are not actually taken up by the root, though converted to purposes of utility by acting as astringents or corrosives in stopping up the orifices of the vessels of the plant, and preventing the admission of too much water: but it is to be recollected that the salts in question are found by analysis in the very substance of the plant, and must consequently have entered in solution. It has been also thought that salts are favorable to vegetation only in proportion as they hasten the putrefaction of vegetable substances contained in the soil, or attract the humidity of the atmosphere. But sulphate of lime is not deliquescent; and if its action consist merely in accelerating putrefaction, why is its beneficial effect confined but to a small number of plants? *Grisenthwaite* (*New Theory of Agriculture*, 1819, p. 111.) answers this question by stating, that as in the principal grain-crops which interest the agriculturist, there exists a particular saline substance, pe-

cular to each, so, if we turn our attention to the clovers and turnips, we shall still find the same discrimination. Saintfoin, clover, and lucerne, have long been known to contain a notable quantity of gypsum (sulphate of lime); but such knowledge, very strange to relate, never led to the adoption of gypsum as a manure for those crops, any more than that of phosphate of lime for wheat, or nitrate of soda, or potassa for barley. It is true that gypsum has been long, and in various places, recommended as a manure, but its uses not being understood, it was recommended without any reference to crop, or indeed to the accomplishment of any fixed object. It is very well known that some particular ingredients may be essential to the composition of a body, and yet constitute but a very small proportion of its mass. Atmospheric air contains only about one part in the 100 of carbonic acid; and yet no one will venture to affirm that carbonic acid gas is merely an adventitious and accidental element existing by chance in the air of the atmosphere, and not an essential ingredient in its composition. Phosphate of lime constitutes but a very small proportion of animal bodies, perhaps not one part in 500; and yet no one doubts that it is essential to the composition of the bones. But the same salt is found in the ashes of all vegetables; and who will say that is not essential to their perfection?

1505. *Earths.* As most plants have been found by analysis to contain a portion of alkaline or earthy salts, so most plants have been found to contain also a portion of earths: and as the two substances are so nearly related, and so foreign in their character to vegetable substances in general, the same enquiry has consequently been made with regard to their origin. Whence are the earths derived that have been found to exist in plants? Chiefly from the soil. But in what peculiar state of combination do they enter the vessels of the plant? The state most likely to facilitate their absorption is that of their solution in water, in which all the earths hitherto found in plants are known to be in a slight degree soluble. If it be said that the proportion in which they are soluble is so very small that it scarcely deserves to be taken into the account, it is to be recollected that the quantity of water absorbed by the plant is great, while that of the earth necessary to its health is but little, so that it may easily be acquired in the progress of vegetation. Such is the manner in which their absorption seems practicable: and Woodward's experiments afford a presumption that they are actually absorbed by the root.

1506. *The proportion of earths contained in the ashes of vegetables* depends upon the nature of the soil in which they grow. The ashes of the leaves of the rhododendron ferrugineum, growing on Mount Jura, a calcareous mountain, yielded 43·25 parts of earthy carbonate, and only 0·75 of silica. But the ashes of leaves of the same plants, growing on Mount Breven, a granitic mountain, yielded two parts of silica, and only 16·75 of earthy carbonate. It is probable however, that plants are not indebted merely to the soil for the earthy particles which they may contain. They may acquire them partly from the atmosphere. Margray has shown that rain-water contains silica in the proportion of a grain to a pound; which, if it should not reach the root, may possibly be absorbed along with the water that adheres to the leaves. But although the earths are thus to be regarded as constituting a small proportion of vegetable food, they are not of themselves sufficient to support the plant, even with the assistance of water. Giobert mixed together lime, alumine, silica, and magnesia, in such proportions as are generally to be met with in fertile soils, and moistened them with water. Several different grains were then sown in this artificial soil, which germinated indeed, but did not thrive; and perished when the nourishment of the cotyledons was exhausted. It is plain, therefore, that the earths, though beneficial to the growth of some vegetables, and perhaps necessary to the health of others, are by no means capable of affording any considerable degree of nourishment to the plant.

1507. *Supply of food by manures and culture.* With regard to the food of plants derived from the atmosphere, the supply is pretty regular, at least, in as far as the gases are concerned; for they are not found to vary materially in their proportions on any part of the surface of the globe; but the quantity of moisture contained in the atmosphere is continually varying, so that in the same season you have not always the same quantity, though in the course of the year the deficiency is perhaps made up. From the atmosphere, therefore, there is a regular supply of vegetable food kept up by nature for the support of vegetable life, independent of the aid of man: and if human aid were even wanted, it does not appear that it could be of much avail. But this is by no means the case with regard to soils; for if soils are less regular in their composition, they are at least more within the reach of human management. The supply of food may be increased by altering the mechanical or chemical constitution of soils; and by the addition of food in the form of manures. The mechanical constitution of soils may be altered by pulverisation, consolidation, draining, and watering; their chemical properties by aeration and torrifaction; both mechanical and chemical properties, by the addition of earths or other substances; and manures, either liquid or solid, are supplied by irrigation and distribution of dungs and other nourishing matters, with or without their interment. (See Book III.)

1508. *Soils in a state of culture, though consisting originally of the due proportion of ingredients, may yet become exhausted of the principle of fertility by means of too frequent cropping;* whether by repetition or rotation of the same, or of different crops. In this case, it should be the object of the phytologist, as well as of the practical cultivator, to ascertain by what means fertility is to be restored to an exhausted soil, or communicated to a new one. In the breaking up of new soils, if the ground has been wet or

marshy, as is frequently the case, it is often sufficient to prepare it merely by means of draining off the superfluous and stagnant water, and of paring and burning the turf upon the surface. If the soil has been exhausted by too frequent a repetition of the same crop, it often happens that a change of crop will answer the purpose of the cultivator; for although a soil may be exhausted for one sort of grain, it does not necessarily follow that it is also exhausted for another. And accordingly, the practice of the farmer is to sow his crops in rotation, having in the same field a crop, perhaps, of wheat, barley, beans, and tares in succession; each species selecting in its turn some peculiar nutriment, or requiring, perhaps, a smaller supply than the crop that has preceded it. But even upon the plan of rotation, the soil becomes at length exhausted, and the cultivator obliged to have recourse to other means of restoring its fertility. In this case, an interval of repose is considerably efficacious, as may be seen from the increased fertility of fields that have not been ploughed up for many years, such as those used for pasture; or even from that of the walks and paths in gardens when they are again broken up. Hence also the practice of fallowing, and of trenching or deep ploughing, which in some cases has nearly the same effect.

1509. *The fertility of a soil is restored*, in the case of draining, by means of its carrying off all such superfluous moisture as may be lodged in the soil, which is well known to be prejudicial to plants not naturally aquatic, as well as by rendering the soil more firm and compact. In the case of burning, the amelioration is effected by means of the decomposition of the vegetable substances contained in the turf, and subjected to the action of the fire, which disperses part also of the superfluous moisture, but leaves a residue of ashes favorable to future vegetation. In the case of the rotation of crops, the fertility is not so much restored as more completely developed and brought into action; because the soil, though exhausted for one species of grain, is yet found to be sufficiently fertile for another, the food necessary to each being different, or required in less abundance. In the case of the repose of the soil, the restored fertility may be owing to the decay of vegetable substances that are not now carried off in the annual crop, but left to augment the proportion of vegetable mould; or to the accumulation of fertilising particles conveyed to the soil by rains; or to the continued abstraction of oxygen from the atmosphere. In the case of fallows, it is owing undoubtedly to the action of the atmospheric air upon the soil, whether in rendering it more friable, or in hastening the putrefaction of noxious plants; or it is owing to the abstraction and accumulation of oxygen. In the case of trenching, or deep ploughing, it is owing to the increased facility with which the roots can now penetrate to the proper depth, and thus their sphere of nourishment is increased. But it often happens that the soil can no longer be ameliorated by any of the foregoing means, or not at least with sufficient rapidity for the purposes of the cultivator; and in this case there must be a direct and actual application made to it of such substances as are fitted to restore its fertility. Hence the indispensable necessity of manures, which consists chiefly of animal and vegetable remains that are buried and finally decomposed in the soil, from which they are afterwards absorbed by the root of the plant, in a state of solution.

1510. But as *carbon is the principal ingredient furnished by manures*, as contributing to the nourishment of the plant, and is not itself soluble in water, nor even disengaged by fermentation in a state of purity; under what state of chemical combination is its solution effected? Is it effected in the state of charcoal? It has been thought, indeed, that carbon in the state of charcoal is soluble in water; because water from a dunghill, when evaporated, constantly leaves a residuum of charcoal, as was first ascertained by the experiments of Hassenfratz. But there seem to be reasons for doubting the legitimacy of the conclusion that has been drawn from it; for Senebier found that plants whose roots were immersed in water took up less of the fluid in proportion as it was mixed with water from a dunghill. Perhaps then the charcoal of water from a dunghill is held merely in suspension, and enters the plant under some other modification. But if carbon is not soluble in water in the state of charcoal, in what other state is it soluble? It is soluble in the state of carbonic acid gas. But is this the state in which it actually enters the root? On this subject phytologists have been somewhat divided in opinion. Senebier endeavors to prove that carbonic acid gas, dissolved in water, supplies the roots of plants with almost all their carbon, and founds his arguments upon the following facts:— In the first place, it is known that carbonic acid gas is soluble in water; in the second place, it is known to be contained in the soil, and generated by the fermentation of the materials composing manures; and, in the next place, it is known to be beneficial to vegetation when applied artificially to the roots, at least in a certain degree. This is evident from the following experiment of Ruckert, as well as from several experiments of Saussure's, previously related. Ruckert planted two beans in pots of equal dimensions, filled with garden-mould; the one was moistened with distilled water, and the other with water impregnated with carbonic acid gas. But the latter appeared above ground nine days sooner than the former, and produced twenty-five beans; while the former produced only

fifteen. Now the result of this experiment, as well as the preceding facts, is evidently favorable to the presumption of Senebier, and shows that if carbonic acid is not the state in which carbon enters the plant, it is at least a state preparatory to it; and there are other circumstances tending to corroborate the opinion, resulting from the analysis of the ascending sap of plants. The tears of the vine, when analysed by Senebier, yielded a portion of carbonic acid and earth; and as the ascending sap could not be supposed to have yet undergone much alteration, the carbonic acid, like the earth, was probably taken up from the soil. But this opinion, which seems to be so firmly established upon the basis of experiment, Hassenfratz strenuously controverts. According to experiments which he had instituted with an express view to the investigation of this subject, plants which were raised in water impregnated with carbonic acid differed in no respect from such as grew in pure water, and contained no carbon that did not previously exist in the seed. Now if this were the fact, it would be decisive of the point in question. But it is plain from the experiments of Saussure, as related in the preceding section, that Hassenfratz must have been mistaken both with regard to the utility of carbonic acid gas as furnishing a vegetable aliment, and with regard to the augmentation of carbon in the plant. The opinion of Senebier, therefore, may still be correct. It must be acknowledged, however, that the subject is not yet altogether satisfactorily cleared up; and that carbon may certainly enter the plant in some state different from that either of charcoal in solution, or of carbonic acid gas. Is not carbonic acid of the soil decomposed before entering the plant? This is a conjecture of Dr. Thomson's, founded upon the following facts:—the green oxide of iron is capable of decomposing carbonic acid; and many soils contain that oxide. Most soils, indeed, contain iron, either in the state of the brown or green oxide, and it has been found that oils convert the brown oxide into green. But dung and rich soils contain a quantity of oily substance. One effect of manures, therefore, may be that of reducing the brown oxide of iron to the green, thus rendering it capable of decomposing carbonic acid gas, so as to prepare it for some new combination, in which it may serve as an aliment for plants. All this, however, is but a conjecture; and it is more probable that the carbonic acid of the soil enters the root in combination with some other substance, and is afterwards decomposed within the plant itself.

### SECT. III. *Process of Vegetable Nutrition.*

1511. *Plants are nourished in a manner in some degree analogous to the animal economy.* The food of plants, whether lodged in the soil, or wafted through the atmosphere, is taken up by intro-susception in the form of gases or other fluids; it is then known as their sap; this sap ascends to the leaves, where it is elaborated as the blood of animals is in the lungs; it then enters into the general circulation of the plant, and promotes its growth.

1512. *Intro-susception.* As plants have no organ analogous to the mouth of animals, they are enabled to take up the nourishment necessary to their support only by absorption, or inhalation as the chyle into the animal lacteals, or the air into the lungs. The former term is applied to the intro-susception of non-elastic fluids; the latter to that of gaseous fluids. The absorption of non-elastic fluids by the epidermis of plants does not admit of a doubt. It is proved, indisputably, that the leaves not only contain air, but do actually inhale it. It was the opinion of Priestley that they inhale it chiefly by the upper surface. And it has been shown by Saussure, that their inhaling power depends entirely upon the organisation. It has been a question, however, among phytologists, whether it is not also effected by the epidermis of the other parts of the plant. We can scarcely suppose it to be effected by the dry and indurate epidermis of the bark and aged trunks, of which the original organisation is obliterated; nor by that of the larger and more aged branches. But it has been thought there are even some of the soft and succulent parts of the plant by which it cannot be effected, because no pores are visible in their epidermis. Decandolle found no pores in the epidermis of fleshy fruits, such as pears, peaches, and gooseberries; nor in that of roots, or scales of bulbs; nor in any part not exposed to the influence of air and light. It is known, however, that fruits will not ripen, and that roots will not thrive, if wholly deprived of air; and hence it is probable that they inhale it by their epidermis, though the pores by which it enters should not be visible. In the root, indeed, it may possibly enter in combination with the moisture of the soil: but in the other parts of the plant it enters no doubt in the state of gas. Herbs, therefore, and the soft parts of woody plants, absorb moisture and inhale gases from the soil or atmosphere by means of the pores of their epidermis, and thus the plant effects the intro-susception of its food.

1513. *Ascent of the sap.* The means by which the plant effects the intro susception of its food, is chiefly that of absorption by the root. But the fluids existing in the soil when absorbed by the root, are designated by the appellation of sap or lymph; which, before it can be rendered subservient to the purposes of vegetable nutrition, must either

be intermediately conveyed to some viscus proper to give it elaboration, or immediately distributed throughout the whole body of the plant. Our present object, therefore, is that of tracing out the progress of its distribution or ascent. The sap is in motion in one direction or other, if not all the year, at least at occasional periods, as the bleeding of plants in spring and autumn sufficiently illustrates. The plant always bleeds most freely about the time of the opening of the bud; for in proportion as the leaves expand the sap flows less copiously, and when they are fully expanded it entirely ceases. But this suspension is only temporary, for the plant may be made to bleed again in the end of the autumn, at least under certain conditions. If an incision is now made into the body of the tree, after the occurrence of a short but sharp frost, when the heat of the sun or mildness of the air begins to produce a thaw, the sap will again flow. It will flow even where the tree has been but partially thawed, which sometimes happens on the south side of a tree, when the heat of the sun is strong and the wind northerly. At the seasons now specified, therefore, the sap is evidently in motion; but the plant will not bleed at any other season of the year. It has been the opinion of some phytologists, that the motion of the sap is wholly suspended during the winter. But though the great cold of winter, as well as the great heat of summer, is by no means so favorable to vegetation as the milder though more changeable temperature of spring and autumn, yet it does not wholly suspend the movement of the sap. Palms may be made to bleed at any season of the year. And although this is not the case with plants in general, yet there is proof sufficient that the colds of winter do not, even in this climate, entirely prevent the sap from flowing. Buds exhibit a gradual development of parts throughout the whole of the winter, as may be seen by dissecting them at different periods. So also do roots. Evergreens retain their leaves; and many of them, such as the arbutus, laurustinus, and the beautiful tribe of the mosses, protrude also their blossoms, even in spite of the rigor of the season. But all this could not possibly be accomplished, if the motion of the sap were wholly suspended.

1514. *Thus the sap is in perpetual motion with a more accelerated or more diminished velocity throughout the whole of the year; but still there is no decided indication, exhibited in the mere circumstance of the plant's bleeding, of the direction in which the sap is moving at the time; for the result might be the same whether it was passing from the root to the branches, or from the branches to the root. But as the great influx of the sap is effected by means of the pores of the epidermis of the root, it follows that its motion must, at least in the first place, be that of ascent; and such is its direction at the season of the plant's bleeding, as may be proved by the following experiment:—If the bore or incision that has been made in the trunk is minutely inspected while the plant yet bleeds, the sap will be found to issue almost wholly from the inferior side. If several bores are made in the same trunk, one above another, the sap will begin to flow first from the lower bore, and then from those above it. If a branch of a vine be lopped, the sap will issue copiously from the section terminating the part that remains yet attached to the plant; but not from the section terminating the part that has been lopped off. This proves indubitably that the direction of the sap's motion, during the season of the plant's bleeding, is that of ascent. But if the sap flows so copiously during the season of bleeding, it follows that it must ascend with a very considerable force; which force has accordingly been made the subject of calculation. To the stem of a vine cut off about two feet and a half from the ground, Hales fixed a mercurial gauge which he luted with mastic; the gauge was in the form of a syphon, so contrived that the mercury might be made to rise in proportion to the pressure of the ascending sap. The mercury rose accordingly, and reached, at its maximum, to a height of thirty-eight inches. But this was equivalent to a column of water of the height of forty-three feet three and one-third inches; demonstrating a force in the motion of the sap that, without the evidence of experiment, would have seemed altogether incredible.*

1515. *Thus the sap in ascending from the lower to the upper extremity of the plant is propelled with a very considerable force, at least in the bleeding season. But is the ascending sap propelled indiscriminately throughout the whole of the tubular apparatus, or is it confined in its course, to any particular channel? Before the anatomy of plants had been studied with much accuracy, there was a considerable diversity of opinion on the subject. Some thought it ascended by the bark; others thought that it ascended by the bark, wood, and pith indiscriminately; and others thought it ascended between the bark and wood. The first opinion was maintained and supported by Malpighi; and Grew considers that the sap ascends by the bark, wood, and pith, indiscriminately. Du Hamel stript several trees of their bark entirely, which continued, notwithstanding, to live for many years, protruding new leaves and new branches as before. Knight stript the trunk of a number of young crab-trees of a ring of bark half an inch in breadth, but the leaves were protruded, and the branches elongated, as if the operation had not been performed. Du Petit Thouars removed the central wood and pith from the stems of several young sycamore trees, leaving the upper part to be supported only by four pillars of bark: in*

others he removed the bark, liber, and alburnum, leaving the upper part of the tree to be supported solely by the central wood. In both cases the trees lived, so that he concludes the bark and wood can alternately act as the sap's conductor. (*Hist. d'un Morceau de Bois. Hort. Tour. 481.*)

1516. That the sap does not ascend exclusively by the bark is thus rendered sufficiently evident. But it is equally evident that it does not ascend by the pith, at least after the first year; for then, even upon Grew's own supposition, it becomes either juiceless or wholly extinct: and even during the first year it is not absolutely necessary, if at all subservient to the ascent of the sap, as is proved by an experiment of Knight's. Having contrived to abstract from some annual shoots a portion of their pith, so as to interrupt its continuity, but not otherwise materially to injure the fabric of the shoot, Knight found that the growth of the shoots which had been made the subject of experiment was not at all affected by it.

1517. *The sap ascends neither by the bark nor pith, but by the wood only.* But the whole mass of the wood throughout is not equally well adapted for the purpose of conveying it. The interior and central part, or that part that has acquired its last degree of solidity, does not in general afford it a passage. This is proved by what is called the girdling of trees, which consists in making a circular gap or incision quite round the stem, and to the depth of two or three inches, so as to cut through both the bark and alburnum. An oak-tree on which Knight had performed this operation, with a view to ascertain the channel of the sap's ascent, exhibited not the slightest mark of vegetation in the spring following. The sap then does not ascend through the channel of the matured wood. But if the sap ascends neither through the channel of the bark, nor pith, nor matured wood, through what other channel does it actually ascend? The only remaining channel through which it can possibly ascend is that of the alburnum. In passing through the channel of the alburnum, does the sap ascend promiscuously by the whole of the tubes composing it, or is it confined in its passage to any peculiar set? The earliest conjectures recorded on this subject are those of Grew and Malpighi, who, though they maintained that the sap ascends chiefly by the bark, did not yet deny that it ascends also partly by the alburnum or wood. It occurred to succeeding phytologists that the progress of the sap, and the vessels through which it passes, might be traced or ascertained by means of making plants vegetate in colored infusions. Du Hamel steeped the extremities of branches of the fig, elder, honeysuckle, and filbert in common ink. In examining the two former, after being steeped for several days, the part immersed was found to be black throughout, but the upper part was tinged only in the wood, which was colored for the length of a foot, but more faintly and partially in proportion to the height. The pith, indeed, exhibited some traces of ink, but the bark and buds none. In some other examples the external layers of the wood only were tinged. In the honeysuckle the deepest shade was about the middle of the woody layers; and in the filbert there was also observed a colored circle surrounding the pith, but none in the pith itself, nor in the bark.

1518. *Thus it is proved that the sap ascends through the vessels of the longitudinal fibre composing the alburnum of woody plants, and through the vessels of the several bundles of longitudinal fibre constituting the woody part of herbaceous plants.* But it has been already shown that the vessels composing the woody fibre are not all of the same species. There are simple tubes, porous tubes, spiral tubes, mixed tubes, and interrupted tubes. Through which of these, therefore, does the sap pass in its ascent? The best reply to this enquiry has been furnished by Knight and Mirbel. Knight prepared some annual shoots of the apple and horse-chestnut, by means of circular incisions, so as to leave detached rings of bark with insulated leaves remaining on the stem. He then placed them in colored infusions obtained by macerating the skins of very black grapes in water; and, on examining the transverse section at the end of the experiment, it was found that the infusion had ascended by the wood beyond his incisions, and also into the insulated leaves, but had not colored the pith nor bark, nor the sap between the bark and wood. From the above experiment, Knight concludes that the sap ascends through what are called the common tubes of the wood and alburnum, at least till it reaches the leaves. Thus the sap is conveyed to the summit of the alburnum. But Knight's next object was to trace the vessels by which it is conveyed into the leaf. The apple-tree and horse-chestnut were still his subjects of experiment. In the former the leaves are attached to the plants by three strong fibres, or rather bundles of tubes, one in the middle of the leaf-stalk, and one on each side. In the latter they are attached by means of several such bundles. Now the colored fluid was found in each case to have passed through the centre of the several bundles, and through the centre only, tinging the tubes throughout almost the whole length of the leaf-stalk. In tracing their direction from the leaf-stalk upwards, they were found to extend to the extremity of the leaves; and in tracing their direction from the leaf-stalk downwards, they were found to penetrate the bark and alburnum, the tubes of which they join, descending obliquely till they

reach the pith which they surround. From their position Knight calls them central tubes, thus distinguishing them from the common tubes of the wood and albumnum, and from the spiral tubes with which they were every where accompanied as appendages, as well as from a set of other tubes which surrounded them, but were not colored, and which he designates by the appellation of external tubes. The experiment was now transferred to the flower-stalk, and fruit-stalk, which was done by placing branches of the apple, pear, and vine, furnished with flowers not yet expanded, in a decoction of logwood. The central vessels were rendered apparent as in the leaf-stalk. When the fruit of the two former was fully formed, the experiment was then made upon the fruit-stalk, in which the central vessels were detected as before; but the coloring matter was found to have penetrated into the fruit also, diverging round the core, approaching again in the eye of the fruit, and terminating at last in the stamens. It was by means of a prolongation of the central vessels, which did not however appear to be accompanied by the spiral tubes beyond the fruit-stalk. Such then are the parts of the plant through which the sap ascends, and the vessels by which it is conveyed. Entering by the pores of the epidermis, it is received into the longitudinal vessels of the root by which it is conducted to the collar. Thence it is conveyed by the longitudinal vessels of the albumnum, to the base of the leaf-stalk and peduncle; from which it is further transmitted to the extremity of the leaves, flower, and fruit. There remains a question to be asked intimately connected with the sap's ascent. Do the vessels conducting the sap communicate with one another by inoculation or otherwise, so as that a portion of their contents may be conveyed in a lateral direction, and consequently to any part of the plant; or do they form distinct channels throughout the whole of their extent, having no sort of communication with any other set of tubes, or with one another? Each of the two opinions implied in the question has had its advocates and defenders. But Du Hamel and Knight have shown that a branch will still continue to live though the tubes leading directly to it are cut in the trunk; from which it follows that the sap, though flowing the most copiously in the direct line of ascent, is at the same time also diffused in a transverse direction.

1519. *Causes of the sap's ascent.* By what power is the sap propelled? Grew states two hypothesis: its volatile nature and magnetic tendency, aided by the agency of fermentation. Malpighi was of opinion that the sap ascends by means of the contraction and dilatation of the air contained in the air-vessels. M. De la Hire attempted to account for the phenomenon by combining together the theories of Grew and Malpighi; and Borelli, who endeavoured to render their theory more perfect, by bringing to its aid the influence of the condensation and rarification of the air and juices of the plant.

1520. *Agency of heat.* Du Hamel directed his efforts to the solution of the difficulty, by endeavoring to account for the phenomena from the agency of heat, and chiefly on the following grounds:—because the sap begins to flow more copiously as the warmth of spring returns; because the sap is sometimes found to flow on the south side of a tree before it flows on the north side, that is, on the side exposed to the influence of the sun's heat sooner than on the side deprived of it; because plants may be made to vegetate even in the winter, by means of forcing them in a hot-house; and because plants raised in a hot-house produce their fruit earlier than such as vegetate in the open air. There can be no doubt of the great utility of heat in forwarding the progress of vegetation; but it will not therefore follow that the motion and ascent of the sap are to be attributed to its agency. On the contrary, it is very well known that if the temperature exceeds a certain degree, it becomes then prejudicial both to the ascent of the sap and also to the growth of the plant. Hales found that the sap flows less rapidly at mid-day than in the morning; and every body knows that vegetation is less luxuriant at midsummer than in the spring. So also, in the case of forcing, it happens but too often that the produce of the hot-house is totally destroyed by the unskilful application of heat; and if heat is actually the cause of the sap's ascent, how comes it that the degree necessary to produce the effect is so very variable even in the same climate? For there are many plants, such as the arbutus, laurustinus, and the mosses, that will continue not only to vegetate, but to protrude their blossoms and mature their fruit, even in the midst of winter, when the temperature is at the lowest. And in the case of submarine plants the temperature can never be very high; so that although heat does no doubt facilitate the ascent of the sap by its tendency to make the vessels expand, yet it cannot be regarded as the efficient cause, since the sap is proved to be in motion even throughout the whole of the winter. Du Hamel endeavours, however, to strengthen the operation of heat by means of the influence of humidity, as being also powerful in promoting the ascent of the sap, whether as relative to the season of the year or time of the day. The influence of the humidity of the atmosphere cannot be conceived to operate as a propelling cause, though it may easily be conceived to operate as affording a facility to the ascent of the sap in one way or other; which under certain circumstances is capable of most extraordinary acceleration, but particularly in that state of the atmosphere which forbodes or precedes a storm. In such a state a stalk of wheat was observed by Du Hamel to grow three inches in three days; a stalk of barley six inches, and a shoot of a vine almost two feet; but this is a state that occurs but seldom, and cannot be of much service in the general propulsion of the sap. On this intricate but important subject Linnæus appears to have embraced the opinion of Du Hamel, or an opinion very nearly allied to it; but does not seem to have strengthened it by any new accession of argument; so that none of the hitherto alleged causes can be regarded as adequate to the production of the effect.

1521. *Irritability.* Perhaps the only cause that has ever been suggested as appearing to be at all adequate to the production of the effect, is that alleged by Saussure. According to Saussure the cause of the sap's ascent is to be found in a peculiar species of irritability inherent in the sap-vessels themselves, and dependent upon vegetable life; in consequence of which they are rendered capable of a certain degree of contraction, according as the internal surface is affected by the application of stimuli, as well as of subsequent dilatation according as the action of the stimulus subsides; thus admitting and propelling the sap by alternate dilatation and contraction. In order to give elucidation to the subject, let the tube be supposed to consist of an indefinite number of hollow cylinders united one to another, and let the sap be supposed to enter the first cylinder by suction, or by capillary attraction, or by any other adequate means; then the first cylinder being excited by the stimulus of the sap, begins gradually to contract, and to propel the con-



tained fluid into the cylinder immediately above it. But the cylinder immediately above it, when acted on in the same manner, is affected in the same manner; and thus the fluid is propelled from cylinder to cylinder till it reaches the summit of the plant. So also when the first cylinder has discharged its contents into the second, and is no longer acted upon by the stimulus of the sap, it begins again to be dilated to its original capacity, and prepared for the intro-susception of a new portion of fluid. Thus a supply is constantly kept up, and the sap continues to flow. The above is by far the simplest as well as most satisfactory of all theories accounting for the ascent of the sap.

1522. *Contraction and dilatation.* Knight has presented us with a theory which, whatever may be its real value, merits at least our particular notice, as coming from an author who stands deservedly high in the list of phytological writers. This theory rests upon the principle of the contraction and dilatation, not of the sap-vessels themselves, as in the theory of Saussure, but of what Knight denominates the *silver grain*, assisted perhaps by heat and humidity expanding or condensing the fluids. (*Phil. Trans.* 1801.) Keith considers this theory of Knight as beset with many difficulties, and the agency of the alleged cause as totally inadequate to the production of the effect to be accomplished.

1523. *Elaboration of the sap.* The moisture of the soil is no sooner absorbed into the plant than it begins to undergo a change. This is proved by the experiment of making a bore or incision in the trunk of a tree during the season of bleeding; the sap that issues from the wound possesses properties very different from the mere moisture of the soil, as is indicated by means of chemical analysis, and sometimes also by means of a peculiar taste or flavor, as in the case of the birch tree. Hence the sap has already undergone a certain degree of elaboration; either in passing through the glands of the cellular tissue, which it reaches through the medium of a lateral communication, or in mingling with the juices contained in the cells, and thus carrying off a portion of them; in the same manner, we may suppose, that water by filtering through a mineral vein becomes impregnated with the mineral through which it passes. But this primary and incipient stage of the process of elaboration must always of necessity remain a mystery to the phytologist, as being wholly effected in the interior of the plant, and consequently beyond the reach of observation. All he can do, therefore, is to trace out its future progress, and to watch its succeeding changes, in which the *rationale* of the process of elaboration may be more evident.

1524. *The process of elaboration is chiefly operated in the leaf:* for the sap no sooner reaches the leaf, than part of it is immediately carried off by means of perspiration, perceptible or imperceptible; effecting a change in the proportion of its component parts, and by consequence a change in its properties.

1525. *Hales* reared a sun-flower in a pot of earth till it grew to the height of three feet and a half; he then covered the mouth of the pot with a plate of lead, which he cemented so as to prevent all evaporation from the earth contained in it. In this plate he fixed two tubes, the one nine inches in length and of but small diameter, left open to serve as a medium of communication with the external air; the other two inches in length and one in diameter, for the purpose of introducing a supply of water, but kept always shut except at the time of watering. The holes of the bottom of the pot were also shut, and the pot and plant weighed for fifteen successive days in the months of July and August; hence he ascertained not only the fact of transpiration by the leaves, from a comparison of the supply and waste; but also the quantity of moisture transpired in a given time, by subtracting from the total waste the amount of evaporation from the pot. The final result proved that the absorbing power of the root is greater than the transpiring power of the leaves, in the proportion of five to two. Similar experiments were also made upon some species of cabbage, whose mean transpiration was found to be 1 lb. 3oz. per day; and on some species of evergreens, which were found, however, to transpire less than other plants. The same is the case also with succulent plants, which transpire but little in proportion to their mass, and which as they become more firm transpire less. It is known, however, that they absorb a great deal of moisture, though they give it out thus sparingly; which seems intended by nature for the purpose of resisting the great droughts to which they are generally exposed, inhabiting, as they do for the most part, the sandy desert or the sunny rock. Along with his own experiments *Hales* relates also some others that were made by *Miller* of Chelsea; the result of which was that, other circumstances being the same, transpiration is in proportion to the transpiring surface; and is affected by the temperature of the air, sunshine, or drought, promoting it, and cold and wet diminishing or suppressing it entirely. It is also greatest from six o'clock in the morning till noon, and is least during the night. But when transpiration becomes too abundant, owing to excess of heat or drought, the plant immediately suffers and begins to languish; and hence the leaves droop during the day, though they are again revived during the night. For the same or for a similar reason, transpiration has been found also to increase as the heat of summer advances; being more abundant in July than in June, and still more in August than in either of the preceding months, from which last period it begins again to decrease.

1526. *A fluid little different from common water is exhaled* according to the experiments of *Hales* and *Guettard*; in some cases it had the odor of the plant; but *Du Hamel* found that it became sooner putrid than water. Such then are the facts that have been ascertained with regard to the imperceptible perspiration of plants, from which it unavoidably follows that the sap undergoes a very considerable modification in its passage through the leaf.

1527. *Perceptible perspiration*, which is an exudation of sap too gross or too abundant to be dissipated immediately, and which hence accumulates on the surface of the leaf, is the cause of its further modification. It is very generally to be met with in the course of the summer on the leaves of the maple, poplar, and lime-tree; but particularly on the surface exposed to the sun, which it sometimes wholly covers.

1528. *The physical as well as chemical qualities of perspired matter* are very different in different species of plants; so that it is not always merely an exudation of sap, but of sap in a high state of elaboration, or mingled with the peculiar juices or secretions of the plant. Sometimes it is a clear and watery fluid conglomering into large drops, such as are said to have been observed by *Miller*, exuding from the leaves of the musar arbor, or plantain-tree; and such as are sometimes to be seen in hot and calm weather exuding from the leaves of the poplar or willow, and trickling down in such abundance as to resemble a slight shower. This phenomenon was observed by *Sir J. E. Smith*, under a grove of willows in Italy, and

said to occur sometimes even in England. Sometimes it is glutinous, as on the leaf of the lime-tree; sometimes it is waxy, as on the leaves of rosemary; sometimes it is saccharine, as on the orange-leaf; or resinous, as on the leaves of the *cistus creticus*. The cause of this excess of perspiration has not yet been altogether satisfactorily ascertained; though it seems to be merely an effort and institution of nature to throw off all such redundant juices as may have been absorbed, or secretions as may have been formed beyond what are necessary to the due nourishment or composition of the plant, or beyond what the plant is capable of assimilating at the time. Hence the watery exudation is perhaps nothing more than a redundancy of the fluid thrown off by imperceptible perspiration, and the waxy and resinous exudations nothing more than a redundancy of secreted juices; all which may be still perfectly consistent with a healthy state of the plant. But there are cases in which the exudation is to be regarded as an indication of disease, particularly in that of the exudation known by the name of honey-dew, a sweet and viscid substance covering the leaves like a varnish, and sometimes occasioning their decay. Such at least seems to be the fact with regard to the honey-dew of the hop, which, according to the observations of Linnæus, is the consequence of the attacks of the caterpillar of the ghost-moth injuring the root. And such seems also to be the fact with regard to the honey-dew of the beech-tree, and perhaps also the honey-dew of the oak. The sap then in the progress of its ascent from the extremity of the root to the extremity of the leaf undergoes a considerable change, first in its mixing with the juices already contained in the plant, and then in its throwing off a portion at the leaf.

1529. *The sap is further affected by means of the gases entering into the root along with the moisture of the soil, but certainly, by means of the gases inhaled into the leaf; the action and elaboration of which shall now be elucidated.*

1530. *Elaboration of carbonic acid.* The utility of carbonic acid gas as a vegetable food has been already shown; plants being found not only to absorb it by the root along with the moisture of the soil, but also to inhale it by the leaves, at least when vegetating in the sun or during the day. But how is the elaboration of this gas effected? Is it assimilated to the vegetable substance immediately upon entering the plant, or is its assimilation effected by means of intermediate steps? The gas thus inhaled or absorbed is not assimilated immediately, or at least not wholly: for it is known that plants do also evolve carbonic acid gas when vegetating in the shade, or during the night. Priestley ascertained that plants vegetating in confined atmospheres evolve carbonic acid gas in the shade, or during the night, and that the vitiated state of their atmospheres after experiment is owing to that evolution; and Saussure that the elaboration of carbonic acid gas is essential to vegetation in the sun; and, finally, Senebier and Saussure proved that the carbonic acid gas contained in water is abstracted and inhaled by the leaf, and immediately decomposed; the carbon being assimilated to the substance of the plant, and the oxygen in part evolved, and in part also assimilated. The decomposition of carbonic acid gas takes place only during the light of day, though Saussure has made it also probable that plants decompose a part of the carbonic acid gas which they form with the surrounding oxygen even in the dark. But the effect is operated chiefly by means of the leaves and other green parts of vegetables, that is, chiefly by the parenchyma; the wood, roots, petals, and leaves that have lost their green color not being found to exhale oxygen gas. It may be observed, however, that the green color is not an absolutely essential character of the parts decomposing carbonic acid; because the leaves of a peculiar variety of the *atriplex hortensis*, in which all the green parts change to red, do still exhale oxygen gas.

1531. *Elaboration of oxygen.* It has been already shown that the leaves of plants abstract oxygen from confined atmospheres, at least when placed in the shade, though they do not inhale all the oxygen that disappears; and it has been further proved, from experiment, that the leaves of plants do also evolve a gas in the sun. From a great variety of experiments relative to the action and influence of oxygen on the plant, and the contrary, the following is the sum of the results. The green parts of plants, but especially the leaves, when exposed in atmospheric air to the successive influence of the light and shade, inhale and evolve alternately a portion of oxygen gas mixed with carbonic acid. But the oxygen is not immediately assimilated to the vegetable substance; it is first converted into carbonic acid by means of combining with the carbon of the plant, which withers if this process is prevented by the application of lime or potash. The leaves of aquatics, succulent plants, and evergreens consume, in equal circumstances, less oxygen than the leaves of other plants. The roots, wood, and petals, and in short all parts not green, with the exception of some colored leaves, do not effect the successive and alternate inhalation and extrication of oxygen; they inhale it indeed, though they do not again give it out, or assimilate it immediately, but convey it under the form of carbonic acid to the leaves, where it is decomposed. Oxygen is indeed assimilated to the plant, but not directly, and only by means of the decomposition of carbonic acid; when part of it, though in a very small proportion, is retained also and assimilated along with the carbon. Hence the most obvious influence of oxygen, as applied to the leaves, is that of forming carbonic acid gas, and thus presenting to the plants elements which it may assimilate; and perhaps the carbon of the extractive juices absorbed even by the root, is not assimilated to the plant till it is converted by means of oxygen into carbonic acid. But as an atmosphere composed of nitrogen and carbonic acid gas only is not favorable to vegetation, it is probable that oxygen performs also some other function beyond that of merely presenting to the plant, under the modification of carbonic acid, elements which it may assimilate. It may effect also the disengagement of caloric by its union with the carbon of the vegetable, which is the necessary result of such union. But oxygen is also beneficial to the plant from its action on the soil; for when the extractive juices contained in the soil have become exhausted, the oxygen of the atmosphere, by penetrating into the earth and abstracting from it a portion of its carbon, forms a new extract to replace the first. Hence we may account for a number of facts observed by the earlier phytologists, but not well explained. Du Hamel remarked that the lateral roots of plants are always the more vigorous the nearer they are to the surface; but it now appears that they are the most vigorous at the surface, because they have there the easiest access to the oxygen of the atmosphere, or to the extract which it may form. It was observed, also, by the same phytologist, that perpendicular roots do not thrive so well, other circumstances being the same, in a stiff and wet soil as in a friable and dry soil; while plants with slender and divided roots thrive equally well in both: but this is no doubt owing to the obstacles that present themselves to the passage of the oxygen in the former case, on account of the greater depth and smaller surface of the root. It was further observed, that roots which penetrate into dung or into pipes conducting water, divide into immense numbers of fibres, and form what is called the fox-tail root; but it is because they cannot continue to vegetate, except by increasing their points of contact, with the small quantity of oxygen found in such mediums. Lastly, it was observed that plants, whose roots are suddenly overflowed with water remaining afterwards stagnant, suffer sooner than if the accident had happened by means of a continued current. It is because in the former case the oxygen contained in the water is soon exhausted, while in the latter it is not exhausted at all. And hence also we may account for the phenomenon exhibited by plants vegetating in distilled water under a receiver filled with atmospheric air, which having no proper soil to supply the root with nourishment, effect the development of their parts only at the expense of their own proper substance; the interior of the stem, or a portion of the root, or the lower leaves decaying and giving up their extractive juices to the other parts.—Thus it appears that oxygen gas, or that constituent part of the atmospheric air which has been found to be indispensable to the life of animals, is also indispensable to the life of vegetables. But although the presence and action of oxygen is absolutely necessary to the process of vegetation, plants do not thrive so well in an atmosphere of pure oxygen, as in an atmosphere of pure or common air. This was proved by an experiment of Saussure's, who having introduced some plants of *pisum sativum*, that were but just issuing from the seed, into a receiver containing pure oxygen gas,

found that in the space of six days they had acquired only half the weight of such as were introduced at the same time into a receiver containing common air. From whence it follows that oxygen, though the principal agent in the process of vegetation, is not yet the only agent necessary to the health and growth of the plant, and that the proportion of the constituent parts of the atmospheric air is well adapted for the purposes both of vegetable and animal life.

1532. *Decomposition of water.* Although the opinion was proved to be groundless, by which water had been supposed to be convertible into all the different ingredients entering into the composition of the vegetable substance by means of the action of the vital energy of the plant; yet when water was ultimately proved to be a chemical compound, it was by no means absurd to suppose that plants may possess the power of decomposing part, at least, of what they absorb by the root, and thus acquire the hydrogen as well as a portion of the oxygen which, by analysis, they are found to contain. This opinion was accordingly pretty generally adopted, but was not yet proved by any direct experiment. Senebier pointed out several phenomena from which he thought it was to be inferred, but particularly that of the germination of some seeds moistened merely with water, and so situated as to have no apparent contact with oxygen. The decomposition of water was inferred also by Ingenhouz, from the amelioration of an atmosphere of common air into which he had introduced some succulent plants vegetating in pure water. Saussure having gathered a number of plants of the same species, as nearly alike as possible in all circumstances likely to be affected by the experiment, dried part of them to the temperature of the atmosphere, and ascertained their weight; the rest he made to vegetate in pure water, and in an atmosphere of pure oxygen for a given period of time, at the end of which he dried them as before, and ascertained their weight also, which it was thus only necessary to compare with the weight of the former, in order to know whether the plants had increased in solid vegetable substance or not. But after many experiments on a variety of plants, the result always was, that plants when made to vegetate in pure water only, and in an atmosphere of pure oxygen, or of common air deprived of its carbonic acid, scarcely added any thing at all to their weight in a dried state; or if they did, the quantity was too small to be appreciated. But from a subsequent experiment, in which carbonic acid gas was mixed with common air by the same experiment, the decomposition and fixation of water by the vegetating plant is legitimately inferred. It does not appear, however, that plants do in any case decompose water directly; that is, by appropriating its hydrogen and at the same time disengaging its oxygen in the form of gas, which is extricated only by the decomposition of carbonic acid.

1533. *Descent of the proper juice.* When the sap has been duly elaborated in the leaf by means of the several processes that have just been described, it assumes the appellation of the *cambium*, or proper juice of the plant. In this ultimate state of elaboration it is found chiefly in the bark, or rather between the bark and wood, and may very often be distinguished by a peculiar color, being sometimes white, as in the several species of spurge, and sometimes yellow, as in celandine. It is said to be the principal seat of the medical virtues of plants; and was regarded by Malpighi as being to the plant what the blood is to the animal body — the immediate principle of nourishment, and grand support of life; which opinions he endeavours to establish by the following analogies: if the blood escapes from the vessels of the animal body, it forms neither flesh nor bone, but tumors; if the proper juices of the plant are extravasated, they form neither bark nor wood, but a lump of gum, resin, or inspissated juice. The disruption of the blood-vessels and consequent loss of blood, injures and often proves fatal to the animal. The extravasation of the proper juice injures and often proves fatal to vegetables, unless the evil is prevented by the skill and management of the gardener. Whatever may be the value of these remarks as tending to establish the analogy in question, it cannot be doubted that the *cambium* or proper juice constitutes at least the grand principle of vegetable organisation; generating and developing in succession the several organs of the plant, or furnishing the vital principle with the immediate materials of assimilation.

1534. *The proper juice is conveyed to the several parts of the plant by an appropriate set of vessels.* One of the earliest and most satisfactory experiments on this subject, at least as far as regards the return of the proper juice through the leaf and leaf-stalk, is that of Dr. Darwin, which was conducted as follows: a stalk of the *euphorbia helioscopia*, furnished with its leaves and seed-vessels, was placed in a decoction of madder root, so as that the lower portion of the stem and two of the inferior leaves were immersed in it. After remaining so for several days the color of the decoction was distinctly discerned passing along the midrib of each leaf. On the upper side of the leaf many of the ramifications, going from the midrib towards the circumference, were observed to be tinged with red; but on the under side there was observed a system of branching vessels, originated in the extremities of the leaf and carrying not a red but a pale milky fluid, which, after uniting in two sets, one on each side the midrib, descended along with it into the leaf-stalk. These were the vessels returning the elaborated sap. The vessels observable on the upper surface Darwin calls arteries, and those on the under surface he calls veins. To this may be added the more recent discoveries of Knight, who in his experiments, instituted with a view to ascertain the course of the sap, detected in the leaf-stalk, not only the vessels which he calls central tubes, through which the colored infusion ascended, together with their appendages, the spiral tubes; but also another set of vessels surrounding the central tubes, which he distinguishes by the appellation of external tubes, and which appeared to be conveying in one direction or other a fluid that was not colored, but that proved, upon further investigation, to be the descending proper juice. In tracing them upwards they were found to extend to the summit of the leaf, and in tracing them downwards they were found to extend to the base of the leaf-stalk, and to penetrate even into the inner bark. According

to Knight, then, there are three sets of vessels in leaves, the central tubes, the spiral tubes, and the external tubes. But by what means is the proper juice conducted from the base of the leaf-stalk to the extremity of the root? This was the chief object of the enquiry of the earlier phytologists who had not yet begun to trace its progress in the leaf and leaf-stalk; but who were acquainted with facts indicating at least the descent of a fluid in the trunk. Du Hamel stript sixty trees of their bark in the course of the spring, laying them bare from the upper extremity of the sap and branches to the root; the experiment proved indeed fatal to them, as they all died in the course of three or four years. But many of them had made new productions both of wood and bark from the buds downwards, extending in some cases to the length of a foot; though very few of them had made any new productions from the root upwards. Hence it is that the proper juice not only descends from the extremity of the leaf to the extremity of the root, but generates also in its descent new and additional parts. The experiments of Knight on this subject are, if possible, more convincing than even those of Du Hamel. From the trunks of a number of young crab trees he detached a ring of bark of half an inch in breadth. The sap rose in them, and the portion of the trunk above the ring augmented as in other subjects that were not so treated, while the portion below the ring scarcely augmented at all. The upper lips of the wounds made considerable advances downwards, while the lower lips made scarcely any advances upwards; but if a bud was protruded under the ring, and the shoot arising from it allowed to remain, then the portion of the trunk below that bud began immediately to augment in size, while the portion between the bud and incision remained nearly as before. When two circular incisions were made in the trunk so as to leave a ring of bark between them with a leaf growing from it, the portion above the leaf died, while the portion below the leaf lived; and when the upper part of a branch was stripped of its leaves the bark withered as far as it was stript. Whence it is evident that the sap which has been elaborated in the leaves and converted into proper juice, descends through the channel of the bark, or rather between the bark and alburnum to the extremity of the root, effecting the development of new and additional parts. But not only is the bark thus ascertained to be the channel of the descent of the proper juice, after entering the trunk; the peculiar vessels through which it immediately passes, have been ascertained also. In the language of Knight they are merely a continuation of the external tubes already noticed, which after quitting the base of the foot-stalk he describes as not only penetrating the inner bark, but descending along with it and conducting the proper juice to the very extremity of the root. In the language of Mirbel they are the large or rather simple tubes so abundant in the bark of woody plants, though not altogether confined to it; and so well adapted by the width of their diameter to afford a passage to the proper juice.

1535. *Causes of descent.* The proper juice then, or sap elaborated in the leaf, descends by the returning vessels of the leaf stalk, and by the longitudinal vessels of the inner bark, the large tubes of Mirbel and external tubes of Knight, down to the extremity of the root.

1536. *The descent of the proper juice* was regarded by the earlier phytologists as resulting from the agency of gravitation, owing perhaps more to the readiness with which the conjecture suggests itself than to the satisfaction which it gives. But the insufficiency of this cause was clearly pointed out by Du Hamel, who observed in his experiments with ligatures that the tumor was always formed on the side next to the leaves, even when the branch was bent down, whether by nature or art, so as to point to the earth, in which case the power propelling the proper juice is acting not only in opposition to that of gravitation, but with such force as to overcome it. This is an unanswerable argument; and yet it seems to have been altogether overlooked, or at least undervalued in its importance by Knight, who endeavors to account for the effect by ascribing it to the joint operation of gravitation, capillary attraction, the waving motion of the tree, and the structure of the conducting vessels; but the greatest of these causes is gravitation. Certain it is that gravitation has considerable influence in preventing the descent of the sap in young shoots of trees which have grown upright, which, when bent down after being fully grown, form larger buds, and often blossom instead of leaf buds. This practice, with a view to the production of blossom-buds, is frequently adopted by gardeners (*Hort. Trans.* 237.) in training fruit-trees.—These causes are each perhaps of some efficacy; and yet even when taken altogether they are not adequate to the production of the effect. The greatest stress is laid upon gravitation; but its agency is obviously over-rated, as is evident from the case of the pendent shoots of the weeping willow; and if gravitation is so very efficacious in facilitating the descent of the proper juice, how comes its influence to be suspended in the case of the ascending sap? The action of the silver grain will scarcely be sufficient to overcome it; and if it should be said that the sap ascends through the tubes of the alburnum by means of the agency of the vital principle, why may not the same vital principle conduct also the proper juice through the returning vessels of the bark? In short, if, with Saussure, we admit the existence of a contracting power in the former case sufficient to propel the sap from ring to ring, it will be absolutely necessary to admit it also in the latter. Thus we assign a cause adequate to the production of the effect, and avoid at the same time the transgression of that most fundamental principle of all sound philosophy which forbids us to multiply causes without necessity.

#### SECT. IV. *Process of Vegetable Development.*

1537. *The production of the different parts and organs of plants* is effected by the assimilation of the proper juice. The next object of our enquiry, therefore, will be that of tracing out the order of the development of the several parts, together with the peculiar mode of operation adopted by the vital principle. But this mode of operation is not exactly the same in herbaceous and annual plants, as in woody and perennial plants. In the former, the process of development comprises as it were but one act of the vital principle, the parts being all unfolded in immediate succession and without any perceptible interruption till the plant is complete. In the latter, the process is carried on by gradual and definite stages easily cognisable to the senses, commencing with the approach of spring, and terminating with the approach of winter; during which, the functions of the vital principle seem to be altogether suspended, till it is aroused again into action by the warmth of the succeeding spring. The illustration of the latter, however, involves also that of the former; because the growth of the first year exemplifies at the same time the growth of annuals, while the growth of succeeding years exemplifies whatever is peculiar to perennials.

1538. *Elementary organs.* If the embryo, on its escape from the seed and conversion into a plant, is taken and minutely inspected, it will be found to consist of a root, plumule, and incipient stem, which have been developed in consecutive order; and if the plant is taken and dissected at this period of its growth it will be found to be composed

merely of an epidermis enveloping a soft and pulpy substance, that forms the mass of the individual; or it may be furnished also with a central and longitudinal fibre; or with bundles of longitudinal fibres giving tenacity to the whole. These parts have been developed no doubt by means of the agency of the vital principle operating on the proper juice; but what have been the several steps of operation?

1539. *No satisfactory explication of this phenomenon has yet been offered.* It is likely, however, that the rudiments of all the different parts of the plant do already exist in the embryo in such specific order of arrangement as shall best fit them for future development, by the intro-susception of new and additional particles. The pellicle constituting the vegetable epidermis has generally been regarded as a membrane essentially distinct from the parts which it covers, and as generated with a view to the discharge of some particular function. Some phytologists, however, have viewed it in a light altogether different, and have regarded it as being merely the effect of accident, and nothing more than a scurf formed on the exterior and pulpy surface of the parenchyma indurated by the action of the air. It is more probably, however, formed by the agency of the vital principle, even while the plant is yet in embryo, for the very purpose of protecting it from injury when it shall have been exposed to the air in the process of vegetation. There are several respects in which an analogy between the animal and vegetable epidermis is sufficiently striking; they are both capable of great expansion in the growth of the subject; they are both easily re-generated when injured (excepting in the case of induration), and seemingly in the same manner; they are both subject, in certain cases, to a constant decay and repair; and they both protect from injury the parts enclosed.

1540. *Composite organs.* The elucidation of the development of the composite organs involves the discussion of the two following topics:—the formation of the annual plant, and of the original shoot of the perennial; and the formation of the subsequent layers that are annually added to the perennial.

1541. *Annuals and annual shoots.* If a perennial of a year's growth is taken up in the beginning of winter when the leaves, which are only temporary organs, have fallen, it will be found to consist of a root and trunk, surmounted by one or more buds. The root is the radicle expanded into the form peculiar to the species, but the trunk and buds have been generated in the process of vegetation.

1542. *The root or trunk,* if taken and cut into two by means of a transverse section, will be found to consist already of bark, wood, and pith. Here then is the termination of the growth of the annual, and of the first stage of the growth of the perennial: how have their several parts or organs been formed?

1543. *The pith* seems only a modification of the original pulp, and the same hypothesis that accounts for the formation of the one will account also for the formation of the other; but the pith and pulp, or parenchyma, are ultimately converted into organs essentially distinct from one another; though phytologists have been much puzzled to assign to each its respective functions. In the ages in which phytological opinions were formed without enquiry, one of the vulgar errors of the time seems to have been an opinion by which the function of the pith was supposed to be that of generating the stone of fruit, and by which it was thought that a tree deprived of its pith would produce fruit without a stone. (*Phys. des Arb.* liv. i. chap. 3.) But this opinion is by much too absurd to merit a serious refutation. Another early opinion, exhibiting however indications of legitimate enquiry, is that by which the pith was regarded as being analogous to the heart and brain of animals, as related by Malpighi; who did not himself adopt it, but believed the pith to be like the cellular tissue, the viscera in which the sap is elaborated for the nourishment of the plant, and for the protrusion of future buds. Magnol thought that it produces the flower and fruit, but not the wood. Du Hamel regarded it as being merely an extension of the pulp or cellular tissue, without being destined to perform any important function in the process of vegetation. But Linnaeus was of opinion that it produces even the wood; regarding it not only as the source of vegetable nourishment, but as being also to the vegetable what the brain and spinal marrow are to animals, the source and seat of life. In these opinions there may be something of truth, but they have all the common fault of ascribing to the pith either too little or too much. M. Lindsay of Jamaica suggested a new opinion on the subject, regarding it as being the seat of the irritability of the leaves of the mimosa, and Sir J. E. Smith says he can see nothing to invalidate the arguments on which this opinion is founded. Plenck and Knight regard it as destined by nature to be a reservoir of moisture to supply the leaves when exhausted by excess of perspiration. Hence it appears that the peculiar function of the pith has not yet been altogether satisfactorily ascertained; and the difficulty of ascertaining it has been thought to be increased from the circumstance of its seeming to be only of a temporary use in the process of vegetation, by its disappearing altogether in the aged trunk. But although it is thus only temporary as relative to the body of the trunk, yet it is by no means temporary as relative to the process of vegetation; the central part of the aged trunk being now no longer in a vegetating state, and the pith being always present in one shape or other in the annual plant, or in the new additions that are annually made to perennials. The pith then is essential to vegetation in all its stages; and from the analogy of its structure to that of the pulp or parenchyma, which is known to be an organ of elaboration, as in the leaf, the function of the pith is most probably that of giving some peculiar elaboration to the sap.

1544. *The generation of the layer of wood in woody plants,* or of the parts analogous to wood in the case of herbaceous plants, has been hitherto but little attended to. If we suppose the rudiments of all the different parts to exist already in the embryo, then we have only to account for their development by means of the intro-susception and assimilation of sap and proper juice; but if we suppose them to be generated in the course of vegetation, then the difficulty of the case is augmented: and at the best we can only state the result of operations that have been so long continued as to present an effect cognizable to the sense of sight, though the detail of the process is often so very minute as to escape even the nicest observation. All, then, that can be said on the subject, is merely that the tubes, however formed, do, by virtue of the agency of the vital principle operating on the proper juice, always make their appearance at last in a uniform and determinate manner, according to the tribe or species to which the plant belongs, uniting and coalescing so as to form either a circular layer investing the pith, as in woody plants; or a number of divergent layers intersecting the pith, as in some herbaceous plants; or bundles of longitudinal and woody fibre interspersed throughout the pith, as in others. In the same manner we may account for the formation of the layer of bark.

1545. *Perennials and their annual layers.* If a perennial is taken at the end of the second year and dissected as in the example of the first year, it will be found to have increased in height by the addition of a perpendicular shoot consisting of bark, wood, and pith, as in the shoot of the former year; and in diameter by the addition of a new

layer of wood and of bark, generated between the wood and bark of the former year, and covering the original cone of wood, like the paper that covers a sugar-loaf: this is the fact of the mode of augmentation about which phytologists have not differed, though they have differed widely with regard to the origin of the additional layer by which the trunk is increased in diameter. Malpighi was of opinion that the new layer of wood is formed from the liber of the former year.

1546. *The new layer of wood* Linnæus considered as formed from the pith, which is absurd, because the opinion goes to the inversion of the very order in which the layer is formed, the new layer being always exterior to the old one. But according to the most general opinion, the layer was thought to be formed from a substance oozing out of the wood or bark — first, a limpid fluid, then a viscid pulp, and then a thin layer attaching itself to the former; the substance thus exuding from the wood or bark was generally regarded as being merely an extravasated mucilage, which was somehow or other converted into wood and bark: but Du Hamel regarded it as being already an organised substance, consisting of both cellular and tubular tissue, which he designated by the appellation of the *cambium*, or proper juice.

1547. *Knight has thrown the highest degree of elucidation on this, one of the most obscure and intricate processes of the vegetable economy*, in having shown that the sap is elaborated, so as to render it fit for the formation of new parts in the leaf only. If a leaf or branch of the vine is grafted even on the fruit-stalk or tendril, the graft will still succeed; but if the upper part of a branch is stripped of its leaves, the bark will wither as far as it is stripped; and if a portion of bark furnished with a leaf is insulated by means of detaching a ring of bark above and below it, the wood of the insulated portion that is above the leaf is not augmented: this shows evidently that the leaf gives the elaboration necessary to the formation of new parts, and that without the agency of the leaf no new part is generated: — Such then is the mode of the augmentation of the plant in the second year of its growth. It extends in width by a new layer of wood and of bark insinuated between the wood and bark of the former year; and in height by the addition of a perpendicular shoot, or of branches, generated as in the shoot of the first year. But if the plant is taken and dissected at the end of the third year, it will be found to have augmented in the same manner; and so also at the end of the succeeding year as long as it shall continue to live; so that the outermost layer of bark, and innermost layer of wood, must have been originally tangent in the first year of the plant's growth; the second layer of bark, and second layer of wood, in the second year; and so on in the order of succession till you come to the layer of the present year, which will in like manner divide into two portions, the outer forming one or more layers of bark, and the inner forming one or more layers of wood. And hence the origin of the concentric layers of wood and of bark of the trunk. But how are we to account for the formation of the divergent layers, which Du Hamel erroneously supposed to proceed from the pith? The true solution of the difficulty has been furnished by Knight, who, in tracing the result of the operation of budding, observed that the wood formed under the bark of the inserted bud unites indeed confusedly with the stock, though still possessing the character and properties of the wood from which it was taken, and exhibiting divergent layers of new formation which originate evidently in the bark, and terminate at the line of union between the graft and stock.

1548. But how is the formation of the wood that now occupies the place of the pith to be accounted for? It appears that the tubes of which the medullary is composed do, in the process of vegetation, deposit a *cambium*, which forms an interior layer that is afterwards converted into wood for the purpose of filling up the medullary canal.

1549. *Conversion of the albuminum into perfect wood.* In consequence of the increase of the trunk by means of the regular and gradual addition of an annual layer, the layers whether of wood or of bark are necessarily of different degrees of solidity in proportion to their age; the inner layer of bark, and the outer layer of wood, being the softest; and the other layers increasing in their degree of solidity till you reach the centre on the one hand, and the circumference on the other, where they are respectively the hardest, forming perfect wood or highly indurated bark, which sloughs or splits into chinks, and falls off in thick crusts, as in the plane-tree, fir, and birch. What length of time, then, is requisite to convert the albuminum into perfect wood, or the liber into indurated bark; and by what means are they so converted? There is no fixed and definite period of time that can be positively assigned as necessary to the complete induration of the wood or bark, though it seems to require a period of a good many years before any particular layer is converted from the state of albuminum to that of perfect wood; and perhaps no layer has received its final degree of induration till such time as the tree has arrived at its full growth. The induration of the albuminum, and its consequent durability, are attributed by many to the loss of sap which the layer sustains after the period of its complete development; when the supply from the root diminishes, and the waste by evaporation or otherwise is still kept up, inducing a contraction or condensation of its elementary principles that augments the solidity of the layer, in the first degree, and begins the process that future years finish. But Knight believes the induration of the albuminum as distinguishable in the winter to be owing rather to some substance deposited in it in the course of the preceding summer, which he regards as being the proper juice in a concrete or inspissated state, but which is carried off again by the sap as it ascends in the spring.

1550. *Circulation of vegetable juices.* After the discovery of the circulation of the blood of animals, phytologists, who were fond of tracing analogies between the animal and vegetable kingdoms, began to think that there perhaps existed in plants also a circulation of fluids. The sap was supposed to be elaborated in the root. The vessels in which it was propelled to the summit of the plant were denominated arteries; and the vessels in which it is again returned to the root were denominated veins. Du Hamel, while he admits the ascent of the sap, and descent of the proper juice, each in peculiar and appropriate vessels, does not however admit the doctrine of a circulation; which seems, about the middle of the last century, to have fallen into disrepute. For Hales, who contended for an alternate ascent and descent of fluids in the day and night, and in the same vessels, or for a sort of vibratory motion as he also describes it, gave no countenance whatever to the doctrine of a circulation of juices. But the doctrine, as it appears, has been again revived, and has met with the support of some of the most distinguished of modern phytologists. Hedwig is said to have declared himself to be of opinion, that plants have a circulation of fluids similar to that of animals. Corti is said to have discovered a species of circulation in the stem of the chara, but confined, it is believed, within the limits of the internodia. Willdenow has also introduced the subject, and defended the doctrine (*Principles of Botany*, p. 85.); but only by saying he believes a circulation to exist, and that it is impossible for the leafless tree to resist the cold if there be not a circulation of fluids. Knight has given his reasons somewhat in detail; and

though his doctrine of a circulation should be false, yet the account which he gives of the progress and agency of the sap and proper juice, short of circulation, may be true. The sum of the account is as follows:—When the seed is deposited in the ground under proper conditions, moisture is absorbed and modified by the cotyledons, and conducted directly to the radicle, which is by consequence first developed. But the fluid which has been thus conducted to the radicle, mingling no doubt with the fluid which is now also absorbed from the soil, ascends afterwards to the plumelet through the medium of the tubes of the albumen. The plumelet now expands and gives the due preparation to the ascending sap, returning it also in its elaborated state to the tubes of the bark, through which it again descends to the extremity of the root, forming in its progress new bark and new albumen; but mixing also, as he thinks, with the albumen of the former year, where such albumen exists, and so completing the circulation.

1551. *Decomposite organs.* To the above brief sketch of the agency of the vital principle in the generation or growth of the elementary and composite organs, there now remains to be added that of the progress and mode of the growth of the decomposite organs, or organs immediately constituting the plant, as finishing the process of the vegetable developement. This will include the phenomena of the ultimate developement of the root, stem, branch, bud, leaf, flower, and fruit.

1552. *The root.* From the foregoing observations and experiments, it appears that the roots of plants, or at least of woody plants, are augmented in their width by the addition of an annual layer, and in their length by the addition of an annual shoot, bursting from the terminating fibre. But how is the developement of the shoot effected? Is it by the intro-susception of additional particles throughout the whole of its extent; or only by additions deposited at the extremity? In order to ascertain the fact, with regard to the elongation of the root, Du Hamel instituted the following experiment:—Having passed several threads of silver transversely through the root of a plant, and noted the distances, he then immersed the root in water. The upper threads retained always their relative and original situation, and the lowest thread which was placed within a few lines of the end was the only one that was carried down. Hence he concluded that the root is elongated merely by the extremity. Knight, who from a similar experiment obtained the same result, deduced from it also the same conclusion. We may regard it then as certain, that the mode of the elongation of the root is such as is here represented, though in the progress of its development, it may affect a variety of directions. The original direction of the root is generally perpendicular, in which it descends to a considerable depth if not interrupted by some obstacle. In taking up some young oak-trees that had been planted in a poor soil, Du Hamel found that the root had descended almost four feet, while the height of the trunk was not more than six inches. If the root meets with an obstacle it then takes a horizontal direction, not by the bending of the original shoot, but by the sending out of lateral shoots. The same effect also follows if the extremity of the root is cut off, but not always so, for it is a common thing in nursery-gardens, to cut off the tap-roots of drills of seedling oaks without removing them, by a sharp spade, and these generally push out new tap-roots, though not so strong as the former. When a root ceases of its own accord to elongate, it sends out also lateral fibres which become branches, and are always the more vigorous the nearer they are to the trunk, but the lateral branches of horizontal roots are the less vigorous the nearer they are to the end next the trunk. In the former case, the increased luxuriance is perhaps owing to the easy access of oxygen in the upper divisions; but in the latter case, the increased luxuriance of the more distant divisions is not so easily accounted for, if it is not to be attributed to the more ample supply of nutriment which the fibres meet with as they recede from the trunk, particularly if you suppose a number of them lying horizontally and diverging like the radii of a circle. But the direction of roots is so liable to be affected by accidental causes, that there is often but little uniformity even in roots of the same species. If plants were to be sown in a soil of the same density throughout, perhaps there might be at least as much uniformity in the figure and direction of their roots, as of their branches; but this will seldom happen. For if the root is injured by the attacks of insects, or interrupted by stones, or earth of too dense a quality, it then sends out lateral branches, as in the above cases; sometimes extending also in length by following the direction of the obstacle, and sometimes ceasing to elongate, and forming a knot at the extremity. But where the soil has been loosened by digging or otherwise, the root generally extends itself to an unusual length, and where it is both loosened and enriched, it divides into a multiplicity of fibres. This is also the case with the roots of plants vegetating in pots, near a river, but especially in water. Where roots have some considerable obstacle to overcome they will often acquire a strength proportioned to the difficulty: sometimes they will penetrate through the hardest soil to get at a soil more nutritive, and sometimes they will insinuate their fibres into the crevices even of walls and rocks which they will burst or overturn. This of course requires much time, and does much injury to the plant. Roots consequently thrive best in a soil that is neither too loose nor too dense; but as the nourishment which the root absorbs is chiefly taken up by the extremity, so the soil is often more exhausted at some distance from the trunk than immediately around it. Du Hamel regards the small fibres of the root which absorb the moisture of the soil as being analogous to the lacteals of the animal system, which absorb the food digested by the stomach. But the root is rather to be regarded as the mouth of the plant, selecting what is useful to nourishment and rejecting what is yet in a crude and indigestible state; the larger portions of it serving also to fix the plant in the soil and to convey to the trunk the nourishment absorbed by the smaller fibres, which ascending by the tubes of the albumen, is thus conveyed to the leaves, the digestive organs of plants. Du Hamel thinks that the roots of plants are furnished with pre-organised germs by which they are enabled to send out lateral branches when cut, though the existence of such germs is not proved; and affirms that the extremities of the fibres of the root die annually like the leaves of the trunk and branches, and are again annually renewed; which last peculiarity Professor Wildenow affirms also to be the fact, but without adducing any evidence by which it appears to be satisfactorily substantiated. On the contrary, Knight, who has also made some observations on this subject, says, it does not appear that the terminating fibres of the roots of woody plants die annually, though those of bulbous roots are found to do so. But the fibres of creeping plants, as the common crow-foot and strawberry, certainly die annually, as do those of the vine.

1553. *The stem.* The stem, like the root, or at least the stem of woody plants, is also augmented in width by the addition of an annual layer, and in length by the addition of an annual shoot bursting from the terminating bud. Is the development of the shoot issuing from the stem effected in the same manner also? The development of the shoot from the stem is not effected in the same manner as that of the root—by additions to the extremity only, but by the intro-susception of additional particles throughout its whole extent, at least in its soft and succulent state: the longitudinal extension diminishing in proportion as the shoot requires solidity, and ceasing entirely when the wood is perfectly formed; though often continuing at the summit after it had ceased at the base. The extension of the shoot is inversely at its induration, rapid while it remains herbaceous, but slow in proportion as it is converted into wood. Hence moisture and shade are the most favorable to its elongation, because they prevent or retard its induration;

and hence the small cone of wood which is formed during the first year of the plant's growth increases no more after the approach of winter, neither in height nor thickness. Such is the mode of the growth and development of the trunk of perennial and woody plants, to which there exists a striking exception in the growth of the trunk of palms. Their internal structure has been already taken notice of as presenting no concentric or divergent layers, and no medullary canal, but merely an assemblage of large and woody fibres, interspersed without order in a pulp or parenchyma, softer at the centre and gradually becoming harder as it approaches the circumference. When the seed of the palm-tree germinates, it protrudes a circular row of leaves, or of fronds, which crowns the radicle, and is succeeded in the following year by a similar row issuing from the centre or bosom of the former leaves, which ultimately die down to the base. This process is continued for four or five years successively without exhibiting as yet any appearance of a stem, the remaining bases of the leaves or frond forming by their union merely a sort of knob or bulb. At last, however, they constitute by their union an incipient stem, as thick the first year as it ever is after; which in the following year is augmented in height as before, and so on in succession as long as the plant lives, the leaves always issuing from the summit and crowning the stem, which is a regular column, but decaying at the end of the year, and leaving circular marks at the points of insertion, which furrow the surface of the plant, and indicate the years of its growth.

1554. *The branches*, in their mode of growth and development, exhibit nearly the same appearances as the trunk from which they issue. They originate in a bud, and form also a cone that consists of pith, wood, and bark; or rather they form a double cone. For the insertion of the branch into the trunk resembles also a cone whose base is at the circumference, and whose apex is at the centre, at least if it is formed in the first year of the plant's growth, or on the shoot of the present year; but falling short of the centre in proportion to the lateness of its formation, and number of intervening layers. Branches in their development assume almost all varieties of position from the reflected to the horizontal and upright; but the lower branches of trees are said to be generally parallel to the surface of the soil on which they grow, even though that surface should be the sloping side of a hill—owing, as it has been thought, to the evolution of a greater number of buds on the side that forms the obtuse angle with the soil, in consequence of its being exposed to the action of a greater mass of air.

1555. *The bud*, which in the beginning of spring is so very conspicuous on the trees of this country as to be obvious to the most careless observer, is by no means common to all plants, nor to plants of all climates; shrubs in general, and annuals universally, are destitute of buds as well as all plants whatever growing within the tropics, the leaf being in them immediately protruded from the bark. It is only in the woody plants of cold climates, therefore, that we are to look for buds; and in them no new part is added, whether proper to the leaf or flower, without the intervention of a bud. For when the young shoot is produced, it is at the same time furnished with new buds, which are again extended into new shoots in the following spring; and thus the bud is to be regarded as forming, not only the cradle but also the winter quarters of the shoot, for which its coat of tiled and glutinous scales seems admirably well adapted. It is found chiefly in the extremity, or on the surface of the young shoot or branch, and but rarely on the stem, except it be at the collar where it produces suckers. It is also generated for the most part in the axil of the leaves, as may be seen by inspecting the annual shoot of almost any tree at random, though not universally so; for to this rule there exists a curious and singular exception in the bud of the platanus, which is generated in the very centre of the base of the foot-stalk, and is not discoverable till after the fall of the leaf. But how are the buds formed which are thus developed? Malpighi thought they were formed from the pith or cellular tissue, which the latter regarded as viscera destined for the elaboration of the sap and protrusion of future buds. Du Hamel thinks the exterior scales of the bud originate in the interior part of the bark, and Knight relates an experiment from which he thinks it follows that the buds are formed from the descending proper juice. But whatever may be the actual origin of the bud, it is evident that its development does not take place except through the medium of the proper juice, which has been elaborated in the leaves of preceding buds, and originally in those of the plumet; as the young bud does not make its appearance till the leaves of the preceding buds have expanded, and will not ultimately succeed if deprived of them too soon.

1556. *Bulbs* are so very similar to buds both in their origin and development as to require no specific investigation.

1557. *The leaf*. When the leaves burst from the expanding bud, and even long before that period, as may be seen by the dissection of the bud in the winter, they are complete in all their parts. Hence it is obvious that the leaf, like the young shoot, effects its final development by means of the intro-susception of new particles throughout the whole of its dimensions: and yet this law of development is not common to all leaves whatever, for the leaves of liliaceous plants extend chiefly at the point of their junction with the bulb. The effect perhaps of their peculiarity of structure, in being formed of parallel tubes which extend throughout their whole length, without those transverse and branching fibres that constitute what are called the nerves of the leaves of woody plants.

1558. *The flower and fruit*. When the flower bursts from the expanding bud, and even long before that period, it is already complete in all its parts, as may be seen also by the dissection of the bud in winter. Linnæus represents the pistil as originating in the pith, the stamens in the wood, and the corolla and calyx in the inner and outer bark respectively: but this account of their origin, though extremely plausible at first sight, will not bear the test of minute examination, being contradicted by the anatomy of the parts themselves; particularly in the case of compound flowers. Knight in investigating the organisation of the apple and pear, endeavored to ascertain the origin of the several parts by tracing the organs of the fruit-stalk to their termination. In the fruit-stalk he thought he could discover the pith, the central tubes, spiral tubes, and tubes of the bark, together with its epidermis: and in tracing them to their termination, he thought the pith seemed to end in the pistils; the central vessels in the stamens, after diverging round the core and approaching again in the eye of the fruit; and the bark and epidermis in the two external skins. Hence he infers that the flower is a prolongation of the pith, wood, and bark. A question of some considerable importance has arisen out of this subject: does the flower or fruit elaborate sap for its own development, or is it supplied with nourishment from the leaf? By placing small branches of the apple, pear, and vine, with blossoms not expanded, in a decoction of logwood, Knight found that the central vessels were colored by the decoction. By means of a similar experiment on the same subjects after the fruit was formed, the coloring matter was traced through the mass of the fruit to the base of the stamina. And hence it appears that the flower and fruit do possess the power of elaborating sap for their own development. Knight infers from the foregoing data, that the blossom is nourished from the albumen, by means of the mingling of the proper juice, which the albumen may be supposed to contain with the sap in its ascent.

#### SECT. V. *Anomalies of Vegetable Development.*

1559. *A deviation from the general laws of development* is occasioned by the intervention of some accidental cause; or of some cause operating permanently in certain subjects. Hence the anomaly may regard the development either of an individual or a species, and may occur either in the root, stem, branch, leaf, bud, flower, or fruit, according to the circumstances in which it is placed; or it may effect the habit, duration, or physical virtues of the plant.



1560. *The root.* According to the general laws of vegetable developement, plants of the same species are furnished with the same species of root — not producing at one time a woody or fibrous root, and at another time a bulbous root. And yet it is found that there are cases in which changes of this kind do occur. If part of the root of a tree planted by a pond or river, protrudes beyond the bank so as to be partially immersed, it divides at the extremity into innumerable ramifications, or sends out innumerable fibres from the surface, which become again subdivided into fibres still more minute, and give to the whole an appearance something resembling that of the tail of a fox; which has accordingly been denominated by Du Hamel the fox-tail-root. (fig. 231.)

231



1561. *The root of the Phileum pratense,* when growing in a moist soil, which it naturally affects, is uniformly fibrous; but when growing in a dry soil, where it is also often to be found, it is furnished with a bulbous root. The same is the case with the *alopecurus geniculatus*; which, when growing in its native marshes, protrudes a fibrous root, though, when growing in a very dry situation, as on the top of a dry wall, it is found to be furnished with an ovate and juicy bulb. This anomaly also seems to be merely the result of a provision of nature by which the plant is endowed with the capacity of collecting a supply of moisture suited to existing circumstances, and hence of adapting itself to the soil in which it grows.

1562. *The roots of Utricularia minor,* which consist of a number of slender and hair-like filaments, exhibit the singular anomaly of being furnished with a multitude of small and membranous bladders, each containing a transparent and watery fluid, and a small bubble of air, by means of which the plant is kept floating in the water.

1563. *The descending root,* an anomaly which attends some perennials, is at first spindle-shaped and perpendicular, sending out some lateral fibres: but dying at the lower extremity in the course of the succeeding winter, and protruding new fibres from the remaining portion, and even from the lower portion of the stem, in the course of the following spring, which by descending into the soil, draw down the plant with them, so that part of what was formerly stem is now converted into root. This process is repeated every year, and by consequence a portion of the stem is made to descend every year into the earth. The anomaly may be exemplified in the roots of *valeriana diolea*, *tanacetum vulgare*, and *oxalis acetosella*; and will also account for the bitten and truncated appearance of *scabiosa succisa*, or *devil's-bit*.

1564. *The beet-root,* if dissected when about a year old, presents the singular anomaly of being already furnished with from five to eight distinct and concentric circles of longitudinal tubes or sap-vessels, imbedded at regular intervals in its pulp; whereas other biennial roots form only an individual circle each year, and are, consequently, at no time furnished with more than two.

1565. *Migratory roots* depend on a principle similar to the foregoing. If the stem of a descending root happens to be creeping or procumbent instead of being erect, then the lateral shoots from above are carried forward in the direction of that procumbency, so that in the course of a few years the plant has actually changed its place by so much as the stem has been converted into a root. This is well exemplified in the genus *Iris*, which, as it enlarges in circumference, dies in the centre and presents a ring of plants instead of a solitary one. In the case of some aquatics, which float about on the surface of the water as they happen to be driven by the winds, the whole plant may be said to be migratory, as in the case of the genus *Lemna*, and some marine plants.

1566. *Roots changed to branches and branches to roots.* If the stem of a young plum or cherry tree, but particularly of a willow, is taken in the autumn and bent so as that one half of the top may be laid in the earth, one half of the root being at the same time taken carefully out, but sheltered at first from the cold and then gradually exposed to it, and the remaining part of the top and root subjected to the same process in the following year, the branches of the top will become roots, and the ramifications of the root will become branches, protruding leaves, flowers, and fruit in due season.

1567. If the stem of a tree planted by a pond or river is so bent in its growth as to come near to the surface of the water and to be occasionally immersed in it, it will sometimes send out from the under surface a multitude of shoots that will descend into the water, and develop themselves in the manner of the fox-tail-root. Sometimes it happens that a stem, instead of assuming the cylindrical form common to the species, assumes a compressed and flattened form similar to the herbage of the cactus as in the fir-tribe, ash, &c.

1568. *The anomaly of the flattened stem* (fig. 232.) is accounted for by Du Hamel by supposing that an unnatural graft must have taken place in the leaf-bud; and so united shoots that would otherwise have been distinct. Sometimes the stem is disfigured by accidental tumors or bunches projecting from the surface, and forming ultimately what are called knots in the wood. They are very common in the oak and elm, and are produced perhaps by means of some obstruction in the channel of the sap's motion, by which the vessels become convoluted and swell up into a bunch.

232

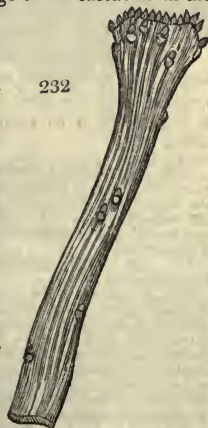

1569. But *bunches* are also to be met with on the stem of herbaceous plants, as on that of the *carduus pratensis*; of which you will often find a portion near the top swollen out into an egg-shaped or egg-oblong bunch, extending from an inch to two inches in length, and about an inch across. If this bunch is cut open in the month of August, it will be found to contain several large and white maggots. It has consequently been occasioned by the puncture of the parent insect depositing its eggs. It does not seem to affect the general health of a vigorous plant, though it might prove seriously injurious to a weak one.

1570. *Bundled stem.* Sometimes two or more contiguous stems, extending in the process of their growth till they meet and press against one another, become incorporated at length into one, and form a sort of bundle. This is what may be termed a natural graft, in opposition to an artificial graft, of which it is the model and prototype. The natural graft is always effected by means of the union of the liber of the respective stems composing it; so that the perfection of the art of grafting consists in applying the liber of the graft and stock together in such a manner as shall most facilitate their incorporation.

1571. If the branch of a tree is situated as in the foregoing case of the stem, so as to be partially or periodically immersed in water, it will send out also the same sort of brush-like shoots.

1572. *Bunches or knots, exhibiting a plexus of young shoots (fig. 233 a.)* issuing from nearly the same point, issuing in all directions, and finally incorporating together by means of a sort of graft, frequently

233

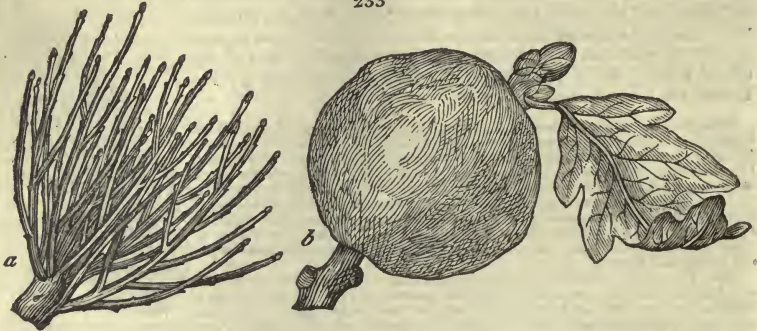

disfigure the branch. These bunches are frequently to be met with on the branches of the birch-tree, and are known among the peasantry of Scotland by the name of witches' knots. They are occasioned, like the bunches of the stem, by some obstruction in the channel of the sap or proper juice. A peculiar sort of knot or nucleus, which is generally from an inch to an inch and a half in diameter, is covered with a long and winged shag, first of a green and then of a purple color, presenting the appearance of a small bunch of moss. (fig. 233 a.) It has been occasioned like that of the stem of the thistle, by the puncture of an insect depositing its eggs in the tender shoot; for if it is cut open about the month of August, it contains maggots. These anomalies remind us always of that singular disease in the human species, the *Plica polonica*.

1573. *The bud.* The regular development of the bud is also often prevented by means of the puncture of insects, and converted into a large globular tumor.

1574. *The gall tumor* is very often effected by a species of *Cynips* that lances its piercer into the heart of the bud while yet tender, and penetrates with its saw into the very pith; injecting at the same time a drop of the corroding liquor contained in its bag, and then laying its eggs. The bud being thus wounded, and the juices corrupted by the injected poison, the circulation is not only impeded, but a fermentation is induced which burns the contiguous parts and changes their color. The extravasated juice flows round the egg, and is there accumulated and converted into a sort of spongy lump which vegetates and augments till it forms what is called a gall. The gall thus formed affords both shelter and nourishment to the young maggot, which, after being converted into a fly, pierces its enclosure and launches into the open air. The most remarkable of such galls are those produced on the oak-tree, and known in this country by the vulgar name of oak-apples. (fig. 233 b.) The bud of the willow, particularly *salix helix*, is apt always to be punctured by insects and converted into a gall. But the conversion is not always complete; and in this case the shoot remains dwarfish, and the leaves, which are now protruded from nearly the same point, assume something of the figure of a rose. Hence it has obtained the common name of the rose-willow. The galls of the *salvia pomifera*, formed in the above manner, are said to be of a very pleasant flavor, and are esteemed a great delicacy in eastern countries.

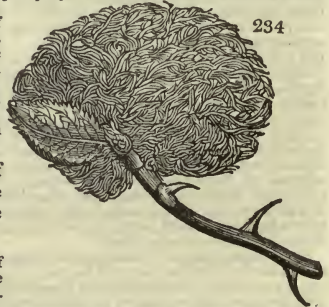

234

1575. *The leaves*, like the buds, are also frequently chosen for the nidus of insects, and disfigured with galls or excrescences. But the most remarkable gall produced on the leaf, and indeed the most remarkable and important of all galls, is that which is so extremely useful in the arts of dyeing and making ink, the nut-gall of the shops.

1576. *The nut-gall* is generated on the leaf of a species of oak that grows plentifully in the Levant, and is so well known in commerce as to require no particular description. It is occasioned by the puncture of the *Cynips quercifolia*, which deposits its egg in the substance of the leaf, by making a small perforation on the under surface. Galls and tumors are to be found on the leaves of many plants; and indeed almost all leaves are liable to deformities, giving them a blistered, wrinkled, or curled appearance; and often producing disease.

1577. *The excess or deficiency of leaves* protruded in a group sometimes constitutes the anomaly, as in the case of the trefoils.

1578. Sometimes in the natural figure of the leaf itself, as in *asparagus officinalis*, where they are bristle-shaped; *salsola kali*, awl-shaped; and *allium cepa*, in which they are tubular, tapering to a point. But one of the most remarkable anomalies of figure is that which occurs in the leaves of the genus *Sarracenia*, of which the lower portion is tubular, ascending, and approaching to funnel-shaped, or rather pitcher-shaped reversed, with a flattened and concave limb attached by the one side to the orifice of the tube, and constituting the upper portion of the leaf. Linnæus, who was acquainted with this singularity of structure, accounted for it by supposing that it was an institution of nature, meant for the purpose of furnishing the plant with a supply of water, which it could thus catch and retain in the leaf. But as some species of the genus do not readily admit water notwithstanding their capacity to retain it, this hypothesis is regarded by Sir J. E. Smith as being extremely doubtful, who accordingly offers a different solution,

founded upon the following facts. An insect of the *Sphex* or *Ichneumon* kind, had been observed by one of the gardeners of the botanic garden at Liverpool, to drag several large flies to a leaf of *sarracenia adunca*, and to force them into the tubular part of it. On examination the leaf was found to be about half filled with water, in which the flies were now struggling; the other leaves were also examined, and were found crammed with dead or drowning flies. The leaves of *sarracenia purpurea* are said to exhibit also the same phenomena, and seem peculiarly well adapted to entrap and confine flies, by having the margin beset with inverted hairs, rendering the escape of such insects as may have accidentally fallen into the watery tube, or are intentionally forced into it, impracticable; so that the putrid exhalation from the dead insects contained in the leaf often offends the nostrils, even in passing near the plant. Hence Sir J. E. Smith infers, that the growth of the plant is perhaps benefited by means of the air evolved by the dead flies, which the water has been intended to tempt, and the leaves to entrap and retain. This ingenious conjecture is, no doubt, sufficiently plausible as far as the plant may be affected; but cannot be regarded as quite satisfactory till such time as it shall have been shown that the health of the plant is injured when insects are prevented from approaching it.

1579. The *ncpenthes distillatoria* exhibits also an anomaly similar to that of *sarracenia*, holding an ounce or two of a fluid which appears to be secreted from the leaf, and to be intended as a lure to insects, which gain admission either by the spontaneous opening of the lid, or by forcibly raising it themselves. The consequence is that they fall into the fluid and are drowned, no insect being capable of living in it except a certain small quilla or shrimp, with a protuberant back, which, according to Linnæus, sometimes crawls into it and can live there. To this phenomenon Sir J. E. Smith applies the same explanation as above, which is of course liable to the same objection.

1580. The figure of the leaf, however singular, is generally the same throughout the same individual, except in the case of accidental deformity, and yet there are exceptions even to this rule. For sometimes the lower leaves of a plant are entire while the upper leaves are divided, as occurs in a variety of mountainous plants, such as burnet, saxifrage, anise, coriander; and sometimes the lower leaves are divided while the upper leaves are entire, as in the case of a variety of aquatics, particularly *ranunculus aquaticus*, in which the lower leaves are capillary and immersed, and the upper leaves flat and circular, floating on the surface of the water. But sometimes the dissimilitude of the leaves is still more remarkable. The Chinese mulberry, a Botany Bay tree, has not two leaves alike in form on the whole plant. And lastly, there are some plants, as in the case of the fungi, that are wholly destitute of leaves, and hence called aphyllous; while there are others, as in the case of the fuci, that seem to be wholly leaf.

1581. The principal anomaly of the flower, is that by which one of its parts is unduly augmented, to the exclusion or diminution of some of the rest. The flower is then said to be luxuriant, and comprises the three following varieties, the multiplicate, the full, and the proliferous flower.

1582. The multiplicate flower, is sometimes, though rarely, occasioned by an unusual multiplication of the divisions of the calyx, as in *dianthus caryophyllus*, and some of the Alpine grasses. But the anomaly most generally consists in the undue multiplication of the divisions of the corolla, by the conversion of part of the stamens into petals which is occasionally to be met with both in monopetalous and polypetalous flowers. It occurs but seldom, however, in flowers growing in their natural state and habit, though now and then a double flower is met with even in such circumstances.

1583. The full flower is generally described to be that in which the divisions of the corolla are so multiplied as to exclude the stamens and pistils wholly by means of their conversion into petals; which conversion is most readily effected in polypetalous flowers, such as the tulip, poppy, pink, and *ranunculus*; monopetalous flowers seldom being found full. This complete metamorphose is always either the effect of cultivation, or of some concurrence of natural circumstances analogous to it; and is indeed one of the principal objects of the art of the florist; the beauty of the flower, according to general estimation, being thus much augmented. In the full flower the stamens are almost always converted into petals, whence we should perhaps infer their identity of origin. But the pistil is often converted into a leaf, as may be seen by inspecting the flower of the double-blossomed cherry, which generally protrudes from the centre a leaf in miniature. But a flower may become full also by the multiplication of the parts of the nectary, as is sometimes the case in the genus *Aquilegia*, which produces full flowers in three different ways—by the multiplication of the petals to the exclusion of the nectaries, by the multiplication of the nectaries while the proper petals remain. There are also some peculiarities in the manner in which compound flowers become full. Radiated flowers become full sometimes by the multiplication of the floscules of the ray to the exclusion of the floscules of the disk, as in *helianthus*, *anthemis*, and *centaurea*; and sometimes by the multiplication of the floscules of the disk to the exclusion of those of the ray, as in *matricaria* and *bellis*.

1584. The proliferous flower (fig. 235.) is that out of which another flower or another shoot is produced. It is seldom found but in flowers already full; from the centre of which, that is, from the ovary or pistil, it sometimes happens that a new flower and foot-stalk is produced, if the flower is simple, as in the *ranunculus*, *anemone*, and pink; or several flowers and foot-stalks, issuing from the common calyx, if the flower is compound, as in the daisy, hawkweed, and marigold; or a new umbel issuing from the centre of the original umbel, if the flower is umbellate, as in *cornus*. Sometimes the proliferous issue of the full flower is not itself a flower, but a shoot furnished with leaves, as has been sometimes, though rarely, observed in the case of the *anemone* and *rose*. Such are the several varieties of luxuriant flowers, constituting anomalies of excess; but it sometimes happens that there is also in the flower an anomaly of defect in the absence of one of its parts. Examples of this sort are occasionally to be met with in the flowers of *cherianthus cheri*, *campanula pentagonæa*, and *tussilago andrandia*, in which the corolla is altogether wanting, though proper to the species; and in this case the flower is said to be mutilated. Sometimes the anomaly consists in the situation of the flower, which is generally protruded from the extremity or sides of the branches. But the flower of the *ruscus* is protruded from the surface of the leaf; or it may consist in the relative situation of the several parts of the flower. In simple flowers the pistil is invariably central with regard to the stamens; but in compound flowers the pistils are often situated in the circumference and the stamens in the centre. This seems to be the case also with some monœcious plants having their flowers on the same peduncle, as in the examples of the *carex* and *arum*, in which the stamens are more central than the pistils. Sometimes the anomaly consists in the color of the corolla, which will often deviate even in the same species. The general color of the common cowslip (*Primula veris*) is a bright yellow; but an individual is occasionally to be met with, though very rarely, in which the limb or expansion of the corolla is purple with a line of yellow around the border. Sometimes the anomaly consists in the time of flowering. The season proper for the flowering of the apple and pear tree is the month of May; but trees of that sort have



been known to protrude both buds and blossoms even in the month of November. Some plants, however, blow only in the winter, as in the case of the *laurustinus* and *arbutus unedo*; while others blow only in the night, and refuse to expand their petals to the light of the sun. Such is the case of the cactus *grandiflorus*, that produces one of the most magnificent of flowers; but blows only in the night; and is hence known also by the appellation of the night-blowing ceruus. Some plants, such as the ferns, algæ, and fungi, are altogether destitute of conspicuous flowers; and are hence called *Cryptogamous*; but in this respect the fig is perhaps the most singular. The flowers, which in other cases uniformly precede the fruit, are in this case concealed within what is generally denominated the fruit; as may be proved by cutting open a green fig (fig. 236.) by means of a longitudinal section passing through its axis. Great numbers of flowers are then discovered lining a sort of cavity in the axis of the fruit; and hence what is called the fruit or fig, in common language, is rather the receptacle of the flower than any thing else. Most plants have their flowers furnished both with stamens and pistils, and are hence hermaphrodites; but there are also many genera that have the stamens in one flower and the pistils in another, both on the same individual; these are denominated *Monœcious* plants, and are exemplified in the oak and hazel. Other genera have the flowers with stamens on one plant, and the flowers with pistils on another; these are denominated *Diœcious*, and are exemplified in the hop and willow. Others have flowers of all the previous kinds on one and the same plant; these are denominated *Polygamous*, and are exemplified in the genus *Atriplex*.

1585. *The fruit.* The anomalies of the fruit may affect either its number, figure, color, or appendages. The common hazel-nut produces in general but one kernel in one shell; but in the course of opening a considerable number, you will now and then meet with one containing two or three kernels in a shell. This is perhaps best accounted for by supposing, with Du Hamel, that it is the result of an unnatural graft effected in the bud; though some think that the shell does always contain the rudiments of two or more kernels, although it rarely happens that more than one is developed. But if two apples or pears are developed in an incorporated state, which is a case that now and then occurs, it is no doubt best accounted for by the graft of Du Hamel. Sometimes the anomaly consists in the figure of the fruit, which is deformed by tumors or excrescences, in consequence of the bite of insects, or injuries of weather producing warts, moles, or specks. Sometimes it consists in the color, producing green melons and white cucumbers. Sometimes it consists in an appendage of leaves. (fig. 237.)

1586. *Habit.* Some plants, which, when placed in a rich soil, grow to a great height, and affect the habit of a tree, are, when placed in a poor soil, converted into dwarfish shrubs. This may be exemplified in the case of the box-tree; and so also in the case of herbaceous plants; as in that of myosotis, which in dry situations is but short and dwarfish, while in moist situations it grows to such a size as to seem to be altogether a different plant. The habit of the plant is sometimes totally altered by means of cultivation; the *pyrus sativa*, when growing in a wild and uncultivated state, is furnished with strong thorns; but when transferred to a rich and cultivated soil the thorns disappear. This phenomenon, which was observed by Linnæus, was regarded as being equivalent to the taming of animals. But this explication is, like some others of the same great botanist, much more plausible than profound, in place of which Professor Wildenow substitutes the following. The thorns protruded in the uncultivated state of the plant, are buds rendered abortive from want of nourishment, which when supplied with a sufficiency of nourishment, are converted into leaves and branches.

1587. *Physical virtues.* When plants are removed from their native soil and taken into a state of culture, it alters not only their habit but their physical virtues. Thus the sour grape is rendered sweet, the bitter pear pleasant, the dry apricot pulpy, the prickly lettuce smooth, and the acrid celery wholesome. Pot-herbs are also rendered more tender by means of cultivation, and better fitted for the use of man; and so also are all our fine varieties of fruit.

1588. *Duration.* Plants are either annuals, biennials, or perennials, and the species is uniformly of the same class. But it has been found that some plants which are annuals in a cold climate, such as that of Sweden, will become perennials in a hot climate, such as that of the West Indies; this anomaly has been exemplified in *tropæolum*, beet-root, and *malva arborica*; and, on the contrary, some plants, which are perennials in hot climates, are reduced to annuals when transplanted into a cold climate; this has been exemplified in *mirabilis* and *ricinus*.

#### SECT. VI. *Of the Sexuality of Vegetables.*

1589. The doctrine that *plants are of different sexes*, and which constitutes the foundation of the Linnæan system, though but lately established upon the basis of logical induction, is by no means a novel doctrine. It appears to have been entertained even among the original Greeks, from the antiquity of their mode of cultivating figs and palms. Aristotle and Theophrastus maintained the doctrine of the sexuality of vegetables; and Pliny, Dioscorides, and Galen, adopted the division by which plants were then distributed into male and female; but chiefly upon the erroneous principle of habit or aspect, and without any reference to a distinction absolutely sexual. Pliny seems to admit the distinction of sex in all plants whatever, and quotes the case of a palm-tree as exhibiting the most striking example.

1590. *Linnæus*, reviewing with his usual sagacity the evidence on which the doctrine rested, and perceiving that it was supported by a multiplicity of the most incontrovertible facts, resolved to devote his labors peculiarly to the investigation of the subject, and to prosecute his inquiries throughout the whole extent of the vegetable kingdom; which great and arduous enterprise he not only undertook, but accomplished with a success equalled to the unexampled industry with which he pursued it. So that by collecting into one body all the evidence of former discovery or experiment, and by adding much that was original of his own, he found himself at length authorised to draw the important conclusion — that no seed is perfected



237



without the previous agency of the pollen; that the doctrine of the sexes of plants is consequently founded in fact.

1591. *Proofs from the economy of the aquatics.* Many plants of this class that vegetate for the most part wholly immersed in water, and often at a considerable depth, gradually begin to elevate their stems as the season of flowering advances, when they at last rear their heads above the surface of the water, and present their opening blossoms to the sun, till the petals have begun to fade, when they again gradually sink down to the bottom to ripen and to sow their seeds. This very peculiar economy may be exemplified in the case of *ruppia maritima*, and several species of *potamogeton*, common in our ponds and ditches; from which we may fairly infer, that the flowers rise thus to the surface merely to give the pollen an opportunity of reaching the stigma uninjured. But the most remarkable example of this kind is that of the *valisneria spiralis* (fig. 238.), a plant that grows in the ditches of Italy. The plant is of the class *Diccia*, producing its fertile flowers on the extremity of a long and slender stalk (*a*) twisted spirally like a corkscrew, which uncoiling of its own accord, about the time of the opening of the blossom, elevates the flowers to the surface of the water, and leaves them to expand in the open air. The barren flowers (*b*) are produced in great numbers upon short upright stalks issuing from a different root, from which they detach themselves about the time of the expansion of the female blossom, mounting up like little air-bubbles, and suddenly expanding when they reach the surface, where they float about in great numbers among the female blossoms, and often cling to them in clusters, so as to cover them entirely; thus bringing the stamens and pistils into immediate contact, and giving the anthers an opportunity of discharging their pollen immediately over the stigma. When this operation has been performed, the now uncoiled stalk of the female plant begins again to resume its original and spiral form, and gradually sinks down, as it gradually rose, to ripen its fruit at the bottom of the water. We have gathered (in 1819) these stalks, in the canals near Padua, upwards of ten feet long.



#### SECT. VII. Impregnation of the Seed.

1592. *The stamens and pistils are the male and female organs of vegetable generation, and the pollen is the substance by which the impregnation of the seed is effected; but how is the pollen conveyed to the ovary? And what is the amount of its action?*

1593. *Access of the pollen.* When the stamens and pistils are situated near each other, the elastic spring with which the anther flies open, will generally be sufficient to disperse the pollen, so as that part of it must infallibly reach the stigma in such flowers as do not perfect their stamens and pistils at the same time. The pollen is very generally conveyed from the anther to the stigma through the instrumentality of bees, and other insects peculiar to a species. The object of the insect in the discovery of honey, in quest of which, whilst it roves from flower to flower, and rummages the recesses of the corolla, it unintentionally covers its body with pollen, which it conveys to the next flower it visits, and brushes off as it acquired it by rummaging for honey; so that part of it is almost unavoidably deposited on the stigma, and impregnation thus effected. Nor is this altogether so much a work of random as it at first appears. For it has been observed that even insects, which do not upon the whole confine themselves to one species of flower, will yet very often remain during the whole day upon the species they happen first to alight on in the morning; hence the impregnation of the females of *Diacious* plants where no male is near. Hence also a sort of natural crossing of the breed of plants which might probably otherwise degenerate.

1594. *Fecundation of the ovary.* Admitting that the pollen is conducted to the ovary through the channel of the tubes of the style, how after all is the ovary fecundated; or the seed rendered fertile? On this subject naturalists have been much divided; and according to their several opinions have been classed under the respective appellations of ovarists, animalculists, and epigenesists.

1595. *Ovarist.* According to the opinion of the *Ovarist*, the embryo pre-exists in the ovary, and is fecundated by the agency of the pollen as transmitted to it through the style.

1596. *Animalculist.* But the theory of the ovarists is not without its difficulties; for as the embryo is never found to make its appearance till after fecundation, it has been thought that it must necessarily pre-exist in the pollen of the anther; from which it is conveyed to the ovary through the medium of the style, and afterwards matured. This theory was founded upon that of *Lewenhoeck*, with regard to animal generation; which supposes the pre-existence of animalcula in the seminal principle of the male; the animalcula being conveyed *in coitu* to the ovary of the female, where alone they are capable of development.

1597. *Epigenesist.* The difficulties inseparable from both theories, together with the phenomenon of hybrid productions, have given rise also to a third; this is the *Theory of the Epigenesists*, who maintain that the embryo pre-exists neither in the ovary nor pollen, but is generated by the union of the fecundating principles of the male and female organs; the former being the fluid issuing from the pollen when it explodes, and the latter, the fluid that exudes from the surface of the stigma when mature. But if the seed is generated from the union of two fecundating principles which form an intermediate offspring, then female plants of the class *Diccia* ought occasionally to produce seeds whose offspring shall be *Hermaphrodite*, or at least *Monacious*, which was never yet known to happen.

1598. *Hybrids.* Although the arguments of the epigenesists are by no means satisfactory, yet it cannot be denied, that hybrid productions partake of the properties both of the male and female from which they spring. This was long ago proved to be the fact by *Bradley*, and more recently confirmed by the experiments of *Knight*; as well as happily converted to the advantage of the cultivator.

1599. *Vegetable crossing.* Observing that farmers who rear cattle improve the progeny by means of crossing the breed, *Knight* argued from analogy, that the same improvement might be introduced into vegetables. His principal object was that of procuring new and improved varieties of the apple and pear to supply the place of such as had become diseased and unproductive. But as the necessary slowness of all experiments of the kind, with regard to the fruit in question, did not keep pace with the ardor of his desire to obtain information on the subject, he was induced to institute some tentative experiments upon the common pea, — a plant well suited to his purpose, both from its quickness of growth, and from the many varieties in form,

size, and color, which it afforded. In 1787, a degenerate sort of pea was growing in his garden, which had not recovered its former vigor even when removed to a better soil. Being thus a good subject of experiment, the male organs of a dozen of its immature blossoms were destroyed, and the female organs left entire. When the blossoms had attained their mature state, the pollen of a very large and luxuriant grey pea was introduced into the one-half of them, but not into the other. The pods of both grew equally; but the seeds of the half that were unimpregnated withered away without having augmented beyond the size to which they had attained before the blossoms expanded. The seeds of the other half were augmented and matured as in the ordinary process of impregnation; and exhibited no perceptible difference from those of other plants of the same variety; perhaps because the external covering of the seed was furnished entirely by the female. But when they were made to vegetate in the succeeding spring, the effect of the experiment was obvious. The plants rose with great luxuriance, indicating in their stem, leaves, and fruit, the influence of this artificial impregnation; the seeds produced were of a dark grey. By impregnating the flowers of this variety with the pollen of others, the color was again changed, and new varieties obtained, superior in every respect to the original on which the experiment was first made, and attaining in some cases, to a height of more than twelve feet. (*Phil. Trans.* 1789.) Knight thinks his experiments on this subject afford examples of superfetation, a phenomenon, the existence of which has been admitted amongst animals, but of which the proof amongst vegetables is not yet quite satisfactory. Of one species of superfetation he has certainly produced examples; that is, when, by impregnating a white pea-blossom with the pollen both of a white and grey pea, white and grey seeds were obtained. But of the other species of superfetation, in which one seed is supposed to be the joint issue of two males, the example is not quite satisfactory. Such a production is perhaps possible, and further experiments may probably ascertain the fact; but it seems to be a matter of mere curiosity, and not apparently connected with any views of utility.

1600. *The practicability of improving the species*, is rendered strikingly obvious by these experiments; and the ameliorating effect is the same, whether by the male or female; as was ascertained by impregnating the largest and most luxuriant plants with the pollen of the most diminutive and dwarfish, or the contrary. By such means any number of varieties may be obtained, according to the will of the experimenter, amongst which some will no doubt be suited to all soils and situations. Knight's experiments of this kind were extended also to wheat; but not with equal success. For though some very good varieties were obtained, yet they were found not to be permanent. But the success of his experiments on the apple-tree were equal to his hopes. This was, indeed, his principal object, and no means of obtaining a successful issue were left untried. The plants which were obtained in this case were found to possess the good qualities of both of the varieties employed, uniting the greatest health and luxuriance with the finest and best-flavored fruit.

1601. *Improved varieties of every fruit and esculent plant may be obtained by means of artificial impregnation, or crossing*, as they were obtained in the cases already stated. Whence Knight thinks, that this promiscuous impregnation of species has been intended by nature to take place, and that it does in fact often take place, for the purpose of correcting such accidental varieties as arise from seed, and of confining them within narrower limits. All which is thought to be countenanced from the consideration of the variety of methods which nature employs to disperse the pollen, either by the elastic spring of the anthers, the aid of the winds, or the instrumentality of insects. But although he admits the existence of vegetable hybrids, that is, of varieties obtained from the intermixture of different species of the same genus, yet he does not admit the existence of vegetable mules, that is, of varieties obtained from the intermixture of the species of different genera; in attempting to obtain which he could never succeed, in spite of all his efforts. Hence he suspects that where such varieties have been supposed to take place, the former must have been mistaken for the latter. It may be said, indeed, that if the case exists in the animal kingdom, why not in the vegetable kingdom? to which it is, perhaps, difficult to give a satisfactory reply. But from the narrow limits within which this intercourse is in all cases circumscribed, it scarcely seems to have been the intention of nature that it should succeed even among animals. Salisbury is of a different opinion, and considers (*Hort. Trans.* i. 364.) that new species may be created both by bees and the agency of man; and the recent experiments of Herbert, Sweet, and others, seem to confirm this opinion. Sweet's experience leads him to conclude that the plants of all orders strictly natural may be reciprocally impregnated with success, and he has already, in the nursery-gardens of Messrs. Colville, produced many new gerania and rhoderaea.

1602. *A singular or anomalous effect of crossing, or extraneous impregnation*, is the change sometimes undergone by the seed or fruit which is produced by the blossom impregnated. These effects are not uniform results, but they are of frequent occurrence, and have attracted notice from a very early period. John Turner observes (*Hort. Trans.* v. 63.) that Theophrastus and Pliny (*Theophrast. Hist. Plant.* l. ii. c. 4.; *Plinii Hist. Nat.* l. xvii. c. 25.) seem to allude to it, and that the notion was entertained by Bradley, who, in his *New Improvements in Planting and Gardening*, after giving directions for fertilising the female flowers of the hazel with the pollen of the male, says, "By this knowledge we may alter the property and taste of any fruit, by impregnating the one with the farina of another of the same class, as, for example, a codlin with a pearmain, which will occasion the codlin so impregnated to last a longer time [than usual], and be of a sharper taste; or if the winter fruit should be fecundated with the dust of the summer kinds, they will decay before their usual time; and it is from this accidental coupling of the farina of one kind with the other, that in an orchard, where there is a variety of apples, even the fruit gathered from the same tree differs in its flavor and times of ripening; and, moreover, the seeds of those apples so generated, being changed by that means from their natural qualities, will produce different kinds of fruit, if they are sown. Turner, after quoting several instances, and, among others, one from the *Philosophical Transactions* "concerning the effect which the farina of the blossoms of different sorts of apples had on the fruit of a neighboring tree," states upwards of six cases of hybridised apples, that had come within his own observation, and concludes with the remark, that if there does exist in fruits such a liability to change, it will at once be evident to the intelligent cultivator how much care is requisite in growing melons, cucumbers, &c. to secure their true characters, even without reference to saving seed for a future crop. In the same volume of the *Horticultural Transactions* (p. 234.), an account is given of different-colored peas being produced in the same pod by crossing the parent blossom. All these facts seem to contradict the generally received opinion, that crossing only affects the next generation; here it appears to affect the embryo offspring; and a gardener who had no keeping apples in his orchard, might communicate that quality in part to his summer fruit by borrowing the use of a neighbour's blossoms from a late variety. It is probable, however, that such counter-impregnations do not take place readily; otherwise the produce of a common orchard would be an ever-varying round of monstrosities.

#### SECT. VIII. Changes consequent upon Impregnation.

1603. *The peculiar changes consequent upon impregnation*, whether in the flowers or fruit, may be considered as external and internal.

1604. *External changes.* At the period of the impregnation of the ovary the flower has attained to its ultimate state of perfection, and displayed its utmost beauty of coloring and richness of perfume. But as it is now no longer wanted, so it is no longer provided for in the economy of vegetation. Its period of decline has commenced; as is indicated, first by the decay of the stamens, then of the petals, and then of the calyx, which wither and shrink up, and finally detach themselves from the fruit altogether, except in some particular cases in which one or other of them becomes permanent and falls only with the fruit. The

stigma exhibits also similar symptoms of decay, and the style itself often perishes. The parts contiguous to the flower, such as the bracts and floral leaves, are sometimes also affected; and finally the whole plant, at least in the case of annuals, begins to exhibit indications of decay. But while the flower withers and falls, the ovary is advancing to perfection, swelling and augmenting in size, and receiving now all the nutriment by which the decayed parts were formerly supported. Its color begins to assume a deeper and richer tinge; its figure is also often altered, and new parts are even occasionally added — wings, crests, prickles, hooks, bloom, down. The common receptacle of the fruit undergoes also similar changes, becoming sometimes large and succulent, as in the fig and strawberry; and sometimes juiceless and indurated, as in compound flowers.

1605. *Internal changes.* If the ovary is cut open as soon as it is first discoverable in the flower, it presents to the eye merely a pulpy and homogeneous mass. But if it is allowed to remain till immediately before the period of its impregnation, it will now be found to be divisible into several distinct parts, exhibiting an apparatus of cells, valves, and membranes, constituting the pericarp, and sometimes the external coats of the seed. In this case the umbilical cord is also to be distinguished; but the embryo is not yet visible. These changes, therefore, are to be attributed merely to the operation of the ordinary laws of vegetable development, and are not at all dependent upon impregnation. But impregnation has no sooner taken place than its influence begins to be visible; the umbilical cord, which was formerly short and distended, is now generally converted into a long and slender thread. Sometimes the position of the seed is altered. Before impregnation the seeds of *caryophyllus aromaticus* and *netrosideros gumifera*, are horizontal; after impregnation they become vertical. Before impregnation the magnolia seeds are erect; after impregnation they become inverted and pendulous. The figure of the seed is often also altered in passing from its young to its mature state; changing from smooth to angular, from tapering to oval, from oval to round, and from round to kidney-shaped. But all seeds are not brought to maturity, of which the rudiments may exist in the ovary. *Lagœcia* and *hasselquistia*, produce uniformly the rudiments of two seeds, of which they mature but one. But the principal changes resulting from impregnation are operated in the seed itself, which, though previously a homogeneous and gelatinous mass, is now converted into an organised body, or embryo. Such are the phenomena, according to the description of Gärtner, accompanying or following the impregnation of all flowers producing seeds; exceptions occur where the fecundation is spurious and incomplete; where the ovary swells, but exhibits no traces of perfect seed within, as often happens in the vine and tamus; or when barren and fertile seeds are intermingled together in the same ovary. This proceeds from some defect either in the quantity or quality of the pollen; but rather in the quality, as it is not always plants having the most pollen that produce the most seeds. The two stamens of the orchidæ fecundate 8000 seeds, and the five stamens of tobacco fecundate 900: while the 50 stamens of *barringtonia*, the 230 of *tea*, and the 80 of the *caryophylli*, fecundate only two or three ovaries.

### SECT. IX. *The Propagation of the Species.*

1606. *As the life of the vegetable, like that of the animal, is limited to a definite period, and as a continued supply of vegetables is always wanted for the support of animals, what we call art, or nature operating by means of the animal man, has taken care to institute such means as shall secure the multiplying and perpetuating of the species in all possible cases.*

1607. *Equivocal generation.* It was long a vulgar error, countenanced even by the philosophy of the times, that vegetables do often spring up from the accidental mixture of putrid water and earth, or other putrid substances, in the manner of what was called the equivocal generation of animals; or at the very least, that the earth contains the principle of vegetable life in itself, which, in order to develop, it is only necessary to expose to the action of the air. The former alternative of the error has been long ago refuted; the latter has lost its hold, having been also refuted by Malpighi, who proved that the earth produces no plant without the intervention of a seed, or of some other species of vegetable germ deposited in it by nature or by art.

1608. *Propagation by seeds.* When the seed has reached maturity in the due and regular course of the development of its several parts, it detaches itself sooner or later from the parent plant, either singly or along with its pericarp, and drops into the soil, where it again germinates and takes root, and springs up into a new individual. Such is the grand means instituted by nature for the replenishing and perpetuating of the vegetable kingdom.

1609. *Dispersion of seed.* If seeds were to fall into the soil merely by dropping down from the plant, then the great mass of them, instead of germinating and springing up into distinct plants, would grow up only to putrefy and decay; to prevent which consequence nature has adopted a variety of the most efficacious contrivances, all tending to the dispersion of the seed. The first means to be mentioned, is that of the elasticity of the pericarp of many fruits, by which it opens when ripe, with a sort of sudden spring, ejecting the seed with violence, and throwing it some considerable distance from the plant. This may be exemplified in a variety of cases; the seeds of oats when ripe are projected from the calyx with such violence, that in a fine and dry day you may even hear them thrown out with a slight and sudden snap in passing through a field that is ripe. The pericarp of the *Dorsiferous Ferns* (fig. 239 a.) is furnished with a sort of peculiar elastic ring (b), intended, as it would appear, for the very purpose of projecting the seeds. The capsules of the cucumber, geranium geum, and fraxinella, discharge their seeds also when ripe with an elastic jerk. But the pericarp of *impatiens*, which consists of one cell with five valves, exhibits perhaps one of the best examples of this mode of dispersion. If it is accidentally touched when ripe it will immediately burst open, while the valves, coiling themselves up in a spiral form, and springing from the stem, discharge the contained seeds, and scatter them all around. The bursting of the pericarp of some species of pines is also worthy of notice. The pericarp, which is a cone, remains on the tree till the summer succeeding that on which it was produced, the scales being still closed. But when the hot weather has commenced and continued for some time, so as to dry the cone thoroughly, the scales open of their own

239



accord with a sudden jerk, ejecting the contained seeds: and if a number of them happen to burst together, which is often the case, the noise is such as to be heard at some considerable distance. The twisted awn of *avena fatua* (fig. 240.), or wild oat, as well as that of *geranium cicutarium*, and some others, seems to have been intended particularly for the purpose of aiding the further dispersion of the seed, after being discharged from the plant or pericarp. This spiral awn or spring, which is beset with a multitude of fine and minute hairs, possesses the property of contracting by means of drought, and of expanding by means of moisture. Hence it remains of necessity in a perpetual state of contraction or dilatation, dependent upon change of weather; from which, as well as from the additional aid of the fine hairs, which act as so many fulcra, and cling to whatever object they meet, the seed to which it is attached is kept in continual motion till it either germinates or is destroyed. The awn of barley, which is beset with a multitude of little teeth all pointing to its upper extremity, presents also similar phenomena. For when the seed with its awn falls from the ear and lies flat upon the ground, it is necessarily extended in its dimensions by the moisture of the night, and contracted by the drought of the day. But as the teeth prevent it from receding in the direction of the point, it is consequently made to advance in the direction of the base of the seed, which is thus often carried to the distance of many feet from the stalk on which it grew. If any one is yet sceptical with regard to the travelling capacity of the awn, let him only introduce an awn of barley with the seed uppermost between his coat and shirt sleeve at the wrist, when he walks out in the morning, and by the time he returns to breakfast, if he has walked to any great distance, he will find it up at his armpit. This journey has been effected by means of the continued motion of the arm, and consequently of the teeth of the awn acting as feet to carry it forward.

1610. *Where distance of dispersion is required, nature is also furnished with a resource.* One of the most common modes by which seeds are conveyed to a distance from their place of growth is that of the instrumentality of animals. Many seeds are thus carried to a distance from their place of growth merely by their attaching themselves to the bodies of such animals as may happen accidentally to come in contact with the plant in their search after food; the hooks or hairs with which one part or other of the fructification is often furnished serving as the medium of attachment, and the seed being thus carried about with the animal till it is again detached by some accidental cause, and at last committed to the soil. This may be exemplified in the case of the bidens and myosotis, in which the hooks or prickles are attached to the seed itself; or in the case of *galium aparine* and others, in which they are attached to the pericarp; or in the case of the thistle and the burdock, in which they are attached to the general calyx. Many seeds are dispersed by animals in consequence of their pericarps being used as food. This is often the case with the seeds of the drupe, as cherries, sloes, and haws, which birds often carry away till they meet with some convenient place for devouring the pulpy pericarp, and then drop the stone into the soil. And so also fruit is dispersed that has been hoarded for the winter, though even with the view of feeding on the seed itself, as in the case of nuts hoarded up by squirrels, which are often dispossessed by some other animal, that not caring for the hoard scatters and disperses it. Sometimes the hoard is deposited in the ground itself, in which case part of it is generally found to take root and to spring up into plants. Though it has been observed that the ground-squirrel never deprives the kernel of its germ before it deposits the fruit it collects. Crows have been also observed to lay up acorns and other seeds in the holes of fence-posts, which being either forgot or accidentally thrust out, fall ultimately into the earth and germinate. But sometimes the seed is even taken into the stomach of the animal, and afterwards deposited in the soil, having passed through it unhurt. This is often the case with the seed of many species of berry, such as the mistletoe, which the thrush swallows and afterwards deposits upon the boughs of such trees as it may happen to alight upon. The seeds of the *loranthus americanus*, another parasitical plant, are said to be deposited in like manner on the branches of the *cocoloba grandiflora*, and other lofty trees; as also the seeds of *phytolacca decandra*, the berries of which are eaten by the robin, thrush, and wild pigeon. And so also the seeds of currants or roans are sometimes deposited, after having been swallowed by blackbirds or other birds, as may be seen by observing a currant-bush or young roan-tree growing out of the cleft of another tree, where the seed has been left, and where there may happen to have been a little dust collected by way of soil; or where a natural graft may have been effected by the insinuation of the radicle into some chink or cleft. It seems indeed surprising that any seeds should be able to resist the heat and digestive action of the stomach of animals; but it is undoubtedly the fact. Some seeds seem even to require it. The seeds of *magnolia glauca*, which have been brought to this country, are said to have generally refused to vegetate till after undergoing this process, and it is known that some seeds will bear a still greater degree of heat without any injury. Spallanzani mentions some seeds that germinated after having been boiled in water: and Du Hamel gives an account of some others that germinated even after having been exposed to a degree of heat measuring 255° of Fahrenheit. In addition to the instrumentality of brute animals in the dispersion of the seed might be added also that of man, who, for purposes of utility or of ornament, not only transfers to his native soil seeds indigenous to the most distant regions, but sows and cultivates them with care.

1611. *The agency of winds is one of the most effective modes of dispersion instituted by nature.* Some seeds are fitted for this mode of dispersion from their extreme minuteness, such as those of the mosses, lichens, and fungi, which float invisibly on the air, and vegetate wherever they happen to meet with a suitable soil. Others are fitted for it by means of an attached wing, as in the case of the fir-tree and *lirodendron tulipifera*, so that the seed, in falling from the cone or capsule, is immediately caught by the wind, and carried to a distance. Others are peculiarly fitted for it by means of their being furnished with an aigrette or down, as in the case of the dandelion, goat's-beard, and thistle, as well as most plants of the class *Syngenesia*; the down of which is so large and light in proportion to the seed it supports, that it is wafted on the most gentle breeze, and often seen floating through the atmosphere in great abundance at the time the seed is ripe. Some have a tail, as in *clematis vitalba*. Others are fitted for this mode of dispersion by means of the structure of the pericarp, which is also wafted along with them, as in the case of *staphylea trifolia*, the inflated capsule of which seems as if obviously intended thus to aid the dispersion of the contained seed by its exposing to the wind a large and distended surface with but little weight. And so also in the case of the maple, elm, and ash, the capsules of which are furnished, like some seeds, with a membranous wing, which when they separate from the plant the wind immediately lays hold of and drives before it.

1612. *The instrumentality of streams, rivers, and currents of the ocean, is a further means adopted by nature for the dispersion of the seeds of vegetables.* The mountain-stream or torrent washes down to the valley the seeds which may accidentally fall into it, or which it may happen to sweep from its banks when it suddenly overflows them. The broad and majestic river, winding along the extensive plain, and traversing the continents of the world, conveys to the distance of many hundreds of miles the seeds that may have vegetated at its source. Thus the southern shores of the Baltic are visited by seeds which grow





in the interior of Germany, and the western shores of the Atlantic by seeds that have been generated in the interior of America. But fruits indigenous to America and the West Indies have sometimes been found to be swept along by the currents of the ocean to the western shores of Europe. The fruit of *mimosa scandens*, *dolichos pruriens*, *guilandina bonduc*, and *anacardium occidentale*, or cashew-nut, have been thus known to be driven across the Atlantic to a distance of upwards of 2000 miles; and although the fruits now adduced as examples are not such as could vegetate on the coast on which they were thrown, owing to soil or climate, yet it is to be believed that fruits may have been often thus transported to climates or countries favorable to their vegetation.

1613. *Propagation by gems.* Though plants are for the most part propagated by means of seeds, yet many of them are propagated also by means of gems; that is, bulbs and buds.

1614. *The caulinary bulb* is often the means of the propagation of the species: it generally appears in the axil of the leaves, as in *dentaria bulbifera* and *litum bulbiferum*; or between the spokes of their umbels, as in *allium canadense*; in the midst of the spike of flowers, as in *polygonum viviparum* and *poa alpina*. As plants of this last kind are mostly alpine, it has been thought to be an institution or resource of nature to secure the propagation of the species in situations where the seed may fail to ripen.

1615. *The bud*, though it does not spontaneously detach itself from the plant and form a new individual, will yet sometimes strike root and develop its parts if carefully separated by art and planted in the earth; but this is to be understood of the leaf-bud only, for the flower-bud, according to Mirbel, if so treated, always perishes.

1616. *Propagation by the leaves.* The species may sometimes be propagated even by means of the leaves; as in the aloe, sea-onion, and some species of arum, which if carefully deposited in the soil will grow up into new plants, by virtue, no doubt, of some latent gem contained in them. The fungi and lichens, according to Gärtner, are all gemmiferous, having no sexual organs, and no pollen impregnating a germ. In the genus *Lycoperdon*, the gelatinous substance that pervades the cellular tissue is converted into a prolific powder; and in *clavaria*, the fluid contained in the cavities of the plant is converted into a prolific powder also; and in the agarics, hypnum, and polctus, vesicles containing sobiliferous granules are found within the lamina, pores, or tubes. Hedwig, on the contrary, ascribes to the fungi a sexual apparatus, and maintains that the pollen is lodged in the volva. But here it is to be recollected, as in the cases of the scutellæ of the lichens, that all fungi are not furnished with a volva, and consequently not furnished with pollen. The *confervæ* and *ulvæ*, together with the genera *Blasia* and *Riccia*, are also, according to Gärtner, propagated only by gems; while *marchantia*, *anthoceros*, *jungermannia*, and *lycoperdon*, are said to be propagated both by gems and seeds.

1617. *Runners* are young shoots issuing from the collar or summit of the root, and creeping along the surface of the soil; but producing a new root and leaves at the extremity, and forming a new individual, by the decay of the connecting link, as in the strawberry.

1618. *Slips.* The process of raising perennials by slips is well known to gardeners, and should perhaps be regarded as an extension of the old plant, rather than as the generation of a new one; though it serves the purpose of the cultivator equally well as a plant raised from seed, with the additional advantage of bearing fruit much sooner. But how is the root generated which the slip thus produces? If the trunk of a tree is lopped, and all its existing buds destroyed, then there will be protruded from between the wood and bark a sort of protuberant lip or ring formed from the proper juice, and from which there will spring a number of young shoots. The formation of the root in the case of the slip is effected in the same manner, the moisture of the soil encouraging the protrusion of buds at and near the section; and the bud that would have been converted into a branch above ground is converted into a root below.

1619. *Layers.* The mode of propagation by layers is practised upon trees that are delicate, and which cannot readily be propagated by means of slips; in which case the root is generated nearly as in the former case, the soil stimulating the protrusion of buds which are converted into roots. In many plants, such as the currant and laurel, this is altogether a natural process, effected by the spontaneous bending down of a branch to the surface of the soil.

1620. *Suckers or off-sets.* Many plants protrude annually from the collar a number of young shoots, encircling the principal stem and depriving it of a portion of its nourishment, as in the case of most fruit-trees. Others send out a horizontal root, from which there at last issues a bud that ascends above the soil and is converted into a little stem, as in the case of the elm-tree and syringa. Others send out a horizontal shoot from the collar or its neighborhood; or a shoot that ultimately bends down by its own weight till it reaches the ground, in which it strikes root and again sends up a stem as in the currant-bush and laurel. The two former are called *suckers* or *off-sets*, though the term off-set should perhaps be restricted to the young bulbs that issue and detach themselves annually from bulbous roots. The latter is not designated by any particular name, but may be regarded as a sort of natural layer, resembling also, in some respects, the runner; from which, however, it is distinguished in that it never detaches itself spontaneously from the parent plant, as is the case also with the two former. But if either of them is artificially detached, together with a portion of root or a slice of the collar adhering to it, it will now bear transplanting, and will constitute a distinct plant.

1621. *Grafting and budding.* The species is also often propagated, or at least the variety is multiplied, by means of *grafting*, which is an artificial application of a portion of the shoot or root of one tree or plant to the stem, shoot, branch, or root of another, so that the two shall coalesce together and form but one plant. The shoot which is to form the summit of the new individual is called the scion; the stem to which it is affixed is called the stock; and the operation, when effected, the graft. As the graft is merely an extension of the parent plant from which the scion came, and not properly speaking a new individual, so it is found to be the best method of propagating approved varieties of fruit-trees without any danger of altering the quality of the fruit, which is always apt to be incurred in propagation from seed, but never in propagating from the scion. The scion will also bear fruit much sooner than the tree that is raised from seed; and, if effected on a proper stock, will be much more hardy and vigorous than if left on the parent plant. And hence the great utility of grafting in the practice of gardening. Till lately, grafting was confined to the ligneous plants, but it is now successfully practised on the roots and shoots of herbaceous vegetables; and the dahlia is grafted by the root; the melon on the gourd; and the love-apple on the potatoe; the cauliflower on the cabbage, &c. by the shoot. A very ingenious tract has been published on this subject, entitled, *Essai sur la Greffe de l'herbe des plantes et des arbres*, par Monsr. Le Baron de Tschoudy, *Bourgeois de Glaris*. Paris, 1819.

#### SECT. X. Causes limiting the Propagation of the Species.

1622. *Though plants are controlled chiefly by animals*, yet they also control one another. From the various sources of vegetable reproduction, but particularly from the fertility and dispersion of the seed, the earth would soon be overrun with plants of the most prolific species, and converted again into a desert, if it were not that nature has set bounds to their propagation by subjecting them to the controul of man, and to the depredations of the great mass of animals; as well as in confining the germination of their seeds to certain and peculiar habitations arising from soil, climate, altitude, and other circumstances. In order to form an idea of the manner in which these act upon vegetation; imagine that every year an enormous quantity of seeds, produced by the existing

vegetables, are spread over the surface of the globe, by the winds and other causes already mentioned, all of these seeds which fall in places suitable for their vegetation, and are not destroyed by animals, germinate and produce plants; then among these plants, the strongest, and largest, and those to which the soil is best suited, develop themselves in number and magnitude so as to choke the others. Such is the general progress of nature, and among plants, as among animals, the strong flourish at the expense of the weak. These causes have operated for such a length of time, that the greater number of species are now fixed and considered as belonging to certain soils, situations, and climates, beyond which they seldom propagate themselves otherwise than by the hands of man.

#### SECT. XI. *Evidence and Character of Vegetable Vitality.*

1623. *The power of counteracting the laws of chemical affinity* is reckoned the best and most satisfactory evidence of the presence and agency of a vital principle as inherent in any subject. This principle, which seems first to have been instituted by Humboldt, is obviously applicable to the case of animals, as is proved by the process of the digestion of the food, and its conversion into chyle and blood; as well as from the various secretions and excretions effected by the several organs, and effecting the growth and development of the individual, in direct opposition to the acknowledged laws of chemical affinity, which, as soon as the vital principle is extinct, begin immediately to give indication of their action in the incipient symptoms of the putrefaction of the dead body. But the rule is also applicable to the case of vegetables, as is proved by the intro-susception, digestion, and assimilation of the food necessary to their development; all indicating the agency of a principle capable of counteracting the laws of chemical affinity; which, at the period of what is usually called the death of the plant, begin also immediately to act, and to give evidence of their action in the incipient symptoms of the putrefaction of the vegetable. Vegetables are therefore obviously endowed with a species of vitality. But admitting the presence and agency of a vital principle inherent in the vegetable subject, what are the peculiar properties by which this principle is characterised?

1624. *Excitability.* One of the most distinguishable properties of the vital principle of vegetables is that of its excitability or capacity of being acted upon by the application of natural stimuli, impelling it to the exertion of its vegetative powers; the natural stimuli thus impelling it being light and heat.

1625. *The stimulating influence of light* upon the vital principle of the plant is discoverable, whether in the stem, leaf, or flower. The direction of the stem is influenced by the action of light, as well as the color of its leaves. Distance from direct rays of light or weak light produces etiolation, and its absence blanching. The luxuriance of branches depends on the presence and action of light, as is particularly observable in the case of hot-house plants, the branches of which are not so conspicuously directed, either to the flue in quest of heat, or to the door or open sash in quest of air, as to the sun in quest of light. Hence also the branches of plants are often more luxuriant on the south than on the north side; or at least on the side that is best exposed to light. The position of the leaf is also strongly affected by the action of light, to which it uniformly turns its upper surface. This may be readily perceived in the case of trees trained to a wall, from which the upper surface of the leaf is by consequence always turned; being on a south wall turned to the south, and on a north wall turned to the north. And if the upper surface of the leaf is forcibly turned towards the wall and confined in that position for a length of time, it will soon resume its primitive position upon regaining its liberty, but particularly if the atmosphere is clear. The leaves of the mallow are said to exhibit but slight indications of this susceptibility, as also sword-shaped leaves; and also those of the mistletoe are equally susceptible on both sides. It had been conjectured that these effects are partly attributable to the agency of heat; and to try the value of the conjecture, Bonnet placed some plants of the atriplex in a stove heated to 25° of Reaumur. Yet the stems were not inclined to the side from which the greatest degree of heat came; but to a small opening in the stoves. Heat then does not seem to exert any perceptible influence in the production of the above effects. Does moisture? Bonnet found that the leaves of the vine exhibited the same phenomenon when immersed in water, as when left in the open air. Whence it seems probable that light is the sole agent in the production of the effects in question. But as light produces such effects upon the leaves, so darkness or the absence of light produces an effect quite the contrary; for it is known that the leaves of many plants assume a very different position in the night from what they have in the day. This is particularly the case with winged leaves, which, though fully expanded during the day, begin to droop and bend down about sunset and during the fall of the evening dew, till they meet together on the inferior side of the leaf-stalk, the terminal lobe, if the leaf is furnished with one, folding itself back till it reaches the first pair; or the two side lobes, if the leaf is trifoliate, as in the case of common clover. So also the leaflets of the false acacia and liquorice hang down during the night, and those of *mimosa pudica* fold themselves up along the common foot-stalk so as to overlap one another. Linnæus has designated the above phenomenon by the appellation of *The Sleep of Plants*. The expansion of the flower is also effected by the action of light. Many plants do not fully expand their petals except when the sun shines; and hence alternately open them during the day and shut them up during the night. This may be exemplified in the case of papilionaceous flowers in general, which spread out their wings in fine weather to admit the rays of the sun, and again fold them up as the night approaches. It may be exemplified also in the case of compound flowers, as in that of the dandelion and hawkweed. But the most singular case of this kind is perhaps that of the lotus of the Euphrates, as described by Theophrastus, which he represents as rearing and expanding its blossoms by day, closing and sinking down beneath the surface of the water by night so as to be beyond the grasp of the hand, and again rising up in the morning to present its expanded blossom to the sun. The same phenomenon is related also by Pliny. But although many plants open their flowers in the morning and shut them again in the evening, yet all flowers do not open and shut at the same time. Plants of the same species are tolerably regular as to time, other circumstances being the same; and hence the daily opening and shutting of the flower has been denominated by botanists *The Horologium Floræ*. Flowers requiring but a slight application of stimulus open early in the morning, while others requiring more open somewhat later. Some do not open till noon, and some, whose extreme delicacy cannot bear the action of light at all, open only at night, such as the cactus grandiflora, or night-blowing cereus. But it seems somewhat doubtful whether or not light is the sole agent in the present case; for

it has been observed that equatorial flowers open always at the same hour, and that tropical flowers change their hour of opening according to the length of the day. It has been observed also, that the flowers of plants that are removed from a warmer to a colder climate expand at a later hour in the latter. A flower that opens at six o'clock in the morning at Senegal, will not open in France or England till eight or nine, nor in Sweden till ten. A flower that opens at ten o'clock at Senegal, will not open in France or England till noon or later, and in Sweden it will not open at all. And a flower that does not open till noon or later at Senegal, will not open at all in France or England. This seems as if heat or its absence were also an agent in the opening or shutting of flowers; though the opening of such as blow only in the night cannot be attributed either to light or heat. But the opening or shutting of some flowers depends not so much on the action of the stimulus of light as on the existing state of the atmosphere, and hence their opening or shutting betokens change. If the Siberian sow-thistle shuts at night, the ensuing day will be fine; and if it opens, it will be cloudy and rainy. If the African marigold continues shut after seven o'clock in the morning, rain is near at hand. And if the convolvulus arvensis, calendula fluvialis, or anagallis arvensis, are even already open they will shut upon the approach of rain, the last of which, from its peculiar susceptibility, has obtained the name of the poor man's weatherglass. But some flowers not only expand during the light of day; they incline also towards the sun, and follow his course, looking towards the east in the morning, towards the south at noon, and towards the west in the evening; and again returning in the night to their former position in the morning. Such flowers are designated by the appellation of *Heliotropes*, on account of their following the course of the sun; and the movement they thus exhibit is denominated their *rotation*. This phenomenon had been observed by the ancients long before they had made any considerable progress in botany, and had even been interwoven into their mythology, having originated, according to the records of fabulous history, in one of the metamorphoses of early times. Clytie, inconsolable for the loss of the affections of Sol, by whom she had been formerly beloved, and of whom she was still enamoured, is represented as brooding over her griefs in silence and solitude; where, refusing all sustenance, and seated upon the cold ground, with her eyes invariably fixed on the sun during the day, and watching for his return during the night, she is at length transformed into a flower, retaining, as much as a flower can retain it, the same unaltered attachment to the sun. This is the flower which is denominated heliotropium by the ancients, and described by Ovid as *Flos qui ad solem vertitur*. But it is to be observed, that the flower alluded to by Ovid cannot be the heliotropium of the moderns, because Ovid describes it as resembling the violet: much less can it be the sun-flower of the moderns, which is a native of America, and could not consequently have been known to Ovid; so that the true heliotropium of the ancients is perhaps not yet ascertained. Bonnet has further remarked that the ripe ears of corn, which bend down with weight of grain, scarcely ever incline to the north, but always lean more to the south; of the accuracy of which remark any one may easily satisfy himself by looking at a field of wheat ready for the sickle; he will find the whole mass of ears nodding, as if with one consent to the south. The cause of the phenomenon has been supposed to be a contraction of the fibres of the stem or flower-stalk on the side exposed to the sun; and this contraction has been thought by De la Hire and Dr. Hales to be occasioned by an excess of transpiration on the sunny side; which is probably the fact, though there seems upon this principle to be some difficulty in accounting for its returning at night; because if you say that the contracted side expands and relaxes by moisture, what is it that contracts the side that was relaxed in the day? The moisture, of which it is no doubt still full, would counteract the contraction of its fibres, and prevent it from resuming its former position in the morning.

1626. *Heat* as well as light acts also as a powerful stimulus to the exertions of the vital principle. This has been already shown in treating of the process of germination; but the same thing is observable with regard to the development and maturation of the leaves, flower, and fruit; for although all plants produce their leaves, flower, and fruit, annually, yet they do not all produce them at the same period or season. This forms the foundation of what Linnæus has called the *Calendarium Floræ*, including a view of the several periods of the frondescence and efflorescence of plants, together with that of the maturation of the fruit.

1627. *Frondescence*. It must be plain to every observer, that all plants do not protrude their leaves at the same season, and that even of such as do protrude them in the same season, some are earlier and some later. The honeysuckle protrudes them in the month of January; the gooseberry, currant, and elder, in the end of February, or the beginning of March; the willow, elm, and lime-tree, in April; and the oak and ash, which are always the latest among trees, in the beginning or towards the middle of May. Many annuals do not come up till after the summer solstice; and many mosses not till after the commencement of winter. This gradual and successive unfolding of the leaves of different plants seems to arise from the peculiar susceptibility of the species to the action of heat, as requiring a greater or less degree of it to give the proper stimulus to the vital principle. But a great many circumstances will always concur to render the time of the unfolding of the leaves somewhat irregular; because the mildness of the season is by no means uniform at the same period of advancement; and because the leafing of the plant depends upon the peculiar degree of temperature, and not upon the return of a particular day of the year. Hence it has been thought, that no rule could be so good for directing the husbandman in the sowing of his several sorts of grain as the leafing of such species of trees as might be found by observation to correspond best to each sort of grain respectively, in the degree of temperature required. Linnæus (Stillingfleet informs us) instituted some observations on the subject about the year 1750, with a view chiefly to ascertain the time proper for the sowing of barley in Sweden; he regarded the leafing of the birch-tree as being the best indication for that grain, and recommended the institution of similar observations with regard to other sorts of grain, upon the grounds of its great importance to the husbandman, who may be said to attend to it in a manner instinctively; but as all the trees of the same species do not come into leaf precisely at the same time, and as the weather may alter even after the most promising indications, no guide natural or artificial can be absolutely depended on with a view to future results.

1628. *Efflorescence*. The flowering of the plant, like the leafing, seems to depend upon the degree of temperature induced by the returning spring, as the flowers are also protruded pretty regularly at the same successive periods of the season. The nezereon and snowdrop protrude their flowers in February; the primrose in the month of March; the cowslip in April; the great mass of plants in May and June; many in July, August, and September; some not till the month of October, as the meadow saffron; and some not till the approach or middle of winter, as the laurustinus and arbutus. Such at least is the period of their flowering in this country; but in warmer climates they are earlier, and in colder climates they are later. Between the tropics, where the degree of heat is always high, it often happens that plants will flower more than once in the year; because they do not there require to wait till the temperature is raised to a certain height, but merely till the development of their parts can be effected in the regular operation of nature, under a temperature already sufficient. For the greater part, however, they flower during our summer, though plants in opposite hemispheres flower in opposite seasons. But in all climates the time of flowering depends also much on the altitude of the place as well as on other causes affecting the degree of heat. Hence plants occupying the polar regions, and plants occupying the tops of the high mountains of southern latitudes, are in flower at the same season; and hence the same flowers are later in opening in North America than in the same latitudes in Europe, because the surface of the earth is higher, or the winters more severe.

1629. *Maturation of the fruit.* Plants exhibit as much diversity in the warmth and length of time necessary to mature their fruit as in their frondescence and flowering; but the plant that flowers the soonest does not always ripen its fruit the soonest. The hazel-tree, which blows in February, does not ripen its fruit till autumn; while the cherry, that does not blow till May, ripens its fruit in June. It may be regarded, however, as the general rule, that if a plant blows in spring it ripens its fruit in summer, as in the case of the currant and gooseberry; if it blows in summer it ripens its fruit in autumn, as in the case of the vine; and if it blows in autumn it ripens its fruit in the winter. But the meadow-saffron, which blows in the autumn, does not ripen its fruit till the succeeding spring.

1630. Such are the primary facts on which a *Calendarium Floræ*, should be founded. They have not hitherto been minutely attended to by botanists; and perhaps their importance is not quite so much as has been generally supposed; but they are at any rate sufficiently striking to have attracted the notice even of savages. Some tribes of American Indians act upon the very principle suggested by Linnaeus, and plant their corn when the wild plum blooms, or when the leaves of the oak are about as large as a squirrel's ears. The names of some of their months are also designated from the state of vegetation. One is called the budding month, and another the flowering month; one the strawberry month, and another the mulberry month; and the autumn is designated by a term signifying the fall of the leaf. Thus the proposed nomenclature of the French for the months and seasons is founded in nature as well as in reason.

1631. *Cold.* As the elevation of temperature induced by the heat of summer is essential to the full exertion of the energies of the vital principle, so the depression of temperature consequent upon the colds of winter has been thought to suspend the exertion of the vital energies altogether. But this opinion is evidently founded on a mistake, as is proved by the example of such plants as protrude their leaves and flowers in the winter season only, such as many of the mosses; as well as by the dissection of the yet unfolded buds at different periods of the winter, even in the case of such plants as protrude their leaves and blossoms in the spring and summer, and in which, it has been already shown, there is a regular, gradual, and incipient development of parts, from the time of the bud's first appearance till its ultimate opening in the spring. The sap, it is true, flows much less freely, but is not wholly stopped. Du Hamel planted some young trees in the autumn, cutting off all the smaller fibres of the root, with a view to watch the progress of the formation of new ones. At the end of every fortnight he had the plants taken up and examined with all possible care to prevent injuring them, and found that, when it did not actually freeze, new roots were always uniformly developed.

1632. *Energies of life in plants like the process of respiration in animals.* Hence it follows, that even during the period of winter, when vegetation seems totally at a stand, the tree being stripped of its foliage, and the herb apparently withering in the frozen blast, still the energies of vital life are exerted; and still the vital principle is at work, carrying on in the interior of the plant, concealed from human view, and sheltered from the piercing frosts, operations necessary to the preservation of vegetable life, or protrusion of future parts; though it requires the returning warmth of spring to give that degree of velocity to the juices which shall render their motion cognizable to man, as well as that expression to the whole plant which is the most evident token of life: in the same manner as the processes of respiration, digestion, and the circulation of the blood are carried on in the animal subject even while asleep; though the most obvious indications of animal life are the motions of the animal when awake. Heat then acts as a powerful stimulus to the operations of the vital principle, accelerating the motion of the sap, and consequent development of parts; as is evident from the sap's beginning to flow much more copiously as the warmth of spring advances, as well as from the possibility of anticipating the natural period of their development by forcing them in a hot-house. But it is known that excessive heat impedes the progress of vegetation as well as excessive cold; both extremes being equally prejudicial. And hence the sap flows more copiously in the spring and autumn, than in either the summer or winter; as may readily be seen by watching the progress of the growth of the annual shoot, which, after having been rapidly protruded in the spring, remains for a while stationary during the great heat of the summer, but is again elongated during the more moderate temperature of autumn.

1633. *Artificial stimulants.* There are also several substances which have been found to operate as stimulants to the agency of the vital principle when artificially dissolved in water, and applied to the root or branch. Oxygenated muriatic acid has been already mentioned: and the vegetation of the bulbs of the hyacinth and narcissus is accelerated by means of the application of a solution of nitre. Dr. Barton, of Philadelphia, found that a decaying branch of *liriodendron tulipifera*, and a faded flower of the yellow iris, recovered and continued long fresh when put into water impregnated with camphor; though flowers and branches, in all respects similar, did not recover when put into common water.

1634. *Irritability.* Plants are not only susceptible of the action of the natural stimuli of light and heat, exciting them gradually to the exercise of the functions of their dif-

ferent organs in the regular progress of vegetation ; they are susceptible also of the action of a variety of accidental or artificial stimuli, from the application of which they are found to give indications of being endowed also with a property similar to what we call irritability in the animal system. This property is well exemplified in the genus *Mimosa* ; but particularly in that species known by the name of the *Sensitive Plant* ; and the *dionæa muscipula* and *drosera*. But sometimes the irritability resides in the flower, and has its seat either in the stamens or style. The former case is exemplified in the flower of the berberry, and cactus tuna, and the latter in *stylidium glandulosum*.

1635. *Sensation*. From the facts adduced in the preceding sections, it is evident that plants are endowed with a capacity of being acted upon by the application of stimuli, whether natural or artificial, indicating the existence of a vital principle, and forming one of the most prominent features of its character. But besides this obvious and acknowledged property, it has been thought by some phytologists that plants are endowed also with a species of *sensation*. Sir J. E. Smith seems rather to hope that the doctrine may be true, than to think it so.

1636. *Instinct*. There is also a variety of phenomena exhibited throughout the extent of the vegetable kingdom, some of which are common to plants in general, and some peculiar to certain species, that have been thought by several botanical writers to exhibit indications, not merely of sensation, but of *instinct*. The tendency of plants to incline their stem and to turn the upper surface of the leaves to the light, the direction which the extreme fibres of the root will often take to reach the best nourishment, the folding up of the flower on the approach of rain, the rising and falling of the water-lily, and the peculiar and invariable direction assumed by the twining stem in ascending its prop, are among the phenomena that have been attributed to instinct. Keith has endeavoured (*Lin. Trans. xi. p. 11.*) to establish the doctrine of the existence and agency of an instinctive principle in the plant, upon the ground of the direction invariably assumed by the radicle and plumulet respectively, in the germination of the seed.

1637. *Definition of the plant*. But if vegetables are living beings endowed with sensation and instinct, or any thing approaching to it, so as to give them a resemblance to animals, how are we certainly to distinguish the plant from the animal? At the extremes of the two kingdoms the distinction is easy ; the more perfect animals can never be mistaken for plants, nor the more perfect plants for animals, but at the mean, where the two kingdoms may be supposed to unite, the shades of discrimination are so very faint or evanescent that of some individual productions it is almost impossible to say to which of the kingdoms they belong. Hence it is that substances which have at one time been classed among plants, have at another time been classed among animals ; and there are substances to be met with whose place has not yet been satisfactorily determined. Of these I may exemplify the genus *Corallina* (*fig. 241.*), which Linnæus placed among

241

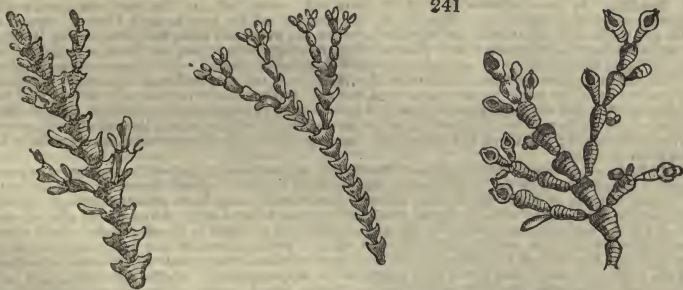

animals, but which Gærtner places among plants. Linnæus, Bonnet, Hedwig, and Mirbel, have each given particular definitions. According to Keith, a vegetable is an organised and living substance springing from a seed or gem, which it again produces ; and effecting the developement of its parts by means of the intro-susception and assimilation of unorganised substances, which it derives from the atmosphere or the soil in which it grows. The definition of the animal is the counterpart : an animal is an organised and living being proceeding from an egg or embryo, which it again produces ; and effecting the development of its parts by means of the intro-susception of organised substances or their products. For all practical purposes, perhaps plants may be distinguished from animals with sufficient accuracy by means of the trial of burning ; as animal substances in a state of ignition exhale a strong and phosphoric odor, which vegetable substances do not.

## CHAP. V.

*Vegetable Pathology, or the Diseases and Casualties of Vegetable Life.*

1638. As plants are, like animals, organised and living beings, they are, like animals also, liable to such *accidental injuries and disorders* as may affect the health and vigor, or occasion the death of the individual. These are wounds, accidents, diseases, and natural decay.

SECT. I. *Wounds and Accidents.*

1639. *A wound* is a forcible separation of the solid parts of the plant effected by means of some external cause, intentional or accidental.

1640. *Incisions* are sometimes necessary to the health of the tree, in the same manner perhaps as bleeding is necessary to the health of the animal. The trunk of the plum and cherry-tree seldom expand freely till a longitudinal incision has been made in the bark; and hence this operation is often practised by gardeners. If the incision affects the epidermis only, it heals up without leaving any scar; if it penetrates into the interior of the bark, it heals up only by means of leaving a scar; if it penetrates into the wood, the wound in the wood itself never heals up completely, but new wood and bark are formed above it as before.

1641. *Boring* is an operation by which trees are often wounded for the purpose of making them part with their sap in the season of their bleeding, particularly the birch tree and American maple. A horizontal or rather slanting hole is bored in them with a wimble, so as to penetrate an inch or two into the wood, from this the sap flows copiously; and though a number of holes is often bored in the same trunk, the health of the tree is not very materially affected. For trees will continue to thrive though subjected to this operation for many successive years; and the hole, if not very large, will close up again like the deep incision, not by the union of the broken fibres of the wood, but by the formation of new bark and wood projecting beyond the edge of the orifice, and finally shutting it up altogether.

1642. *Girdling* is an operation to which trees in North America are often subjected when the farmer wishes to clear his land of timber. It consists in making parallel and horizontal incisions with an axe into the trunk of a tree, and carrying them quite round the stem so as to penetrate through the *albumum*, and then to scoop out the intervening portion. If this operation is performed early in the spring, and before the commencement of the bleeding season, the tree rarely survives it; though some trees that are peculiarly tenacious of life, such as *acer saccharinum* and *nyssa integrifolia*, have been known to survive it a considerable length of time.

1643. *Fracture*. If a tree is bent so as to fracture part only of the cortical and woody fibres, and the stem or branch but small, the parts will again unite by being put back into their natural position, and well propped up. Especially cure may be expected to succeed if the fracture happens in the spring; but it will not succeed if the fracture is accompanied with contusion, or if the stem or branch is large; and even where it succeeds the woody fibres do not contribute to the union, but the granular and herbaceous substance only which exudes from between the wood and liber, insinuating itself into all interstices and finally becoming indurated into wood.

1644. *Pruning*. Wounds are necessarily inflicted by the gardener or forester in the pruning or lopping off the superfluous branches, but this is seldom attended with any bad effects to the health of the tree, if done by a skillful practitioner: indeed no further art is required merely for the protection of the tree beyond that of cutting the branch through in a sloping direction so as to prevent the rain from lodging. In this case the wound soon closes up by the induration of the exposed surface of the section, and by the protrusion of a granular substance, forming a sort of circular lip between the wood and bark; and hence the branch is never elongated by the growth of the same vessels that have been cut, but by the protrusion of new buds near the point of section.

1645. *Grafting*. In the operation of grafting there is a wound both of the stock and graft; which are united, not by the immediate adhesion of the surfaces of the two sections, but by means of a granular and herbaceous substance exuding from between the wood and bark, and insinuating itself as a sort of cement into all open spaces: new wood is finally formed within it, and the union is complete.

1646. *Felling* is the operation of cutting down trees close to the ground, which certain species will survive, if the stump is protected from the injuries of animals, and the root fresh and vigorous. In this case the fibres of the wood are never again regenerated, but a lip is formed as in the case of pruning; and buds, that spring up into new shoots, are protruded near the section; so that from the old shoot, ten, twelve, or even twenty new stems may issue according to its size and vigor. The stools of the oak and ash-tree will furnish good examples; but there are some trees, such as the fir, that never send out any shoots after the operation of felling.

1647. If *buds are destroyed* in the course of the winter, or in the early part of the spring, many plants will again generate new buds that will develop their parts as the others would have done, except that they never contain blossom or fruit. Du Hamel thought these buds sprang from pre-organised germs, which he conceived to be dispersed throughout the whole of the plant; but Knight thinks he has discovered the true source of the regeneration of buds, in the proper juice that is lodged in the albumum. Buds thus regenerated never contain or produce either flower or fruit. Perhaps because the fruit-bud requires more time to develop its parts, or a peculiar and higher degree of elaboration; and that this hasty production is only the effect of a great effort of the vital principle for the preservation of the individual, and one of those wonderful resources to which nature always knows how to resort when the vital principle is in danger. But though such buds do not produce flowers directly, as in the case of plants that bear their blossoms on last year's wood; yet they often produce young shoots which produce blossoms and fruit the same season, as in the case of cutting down an old vine, or pruning the rose.

1648. Sometimes the *leaves of a tree are destroyed* partially or totally as soon as they are protruded from the bud, whether by the depredations of caterpillars or other insects, or by the browsing of cattle. But if the injury is done early in the spring, new leaves will be again protruded without subsequent shoots. Some trees will bear to be stripped even more than once in a season, as is the case with the mulberry-tree, which they cultivate in the south of France and Italy for the purpose of feeding the silkworm. But if it is stripped more than once in the season it requires now and then a year's rest.

1649. *The decortication* of a tree, or the stripping of its bark, may be either intentional or accidental, partial or total. If it is partial, and effects the epidermis only, then it is again regenerated, as in the case of slight incision, without leaving any scar. But if the epidermis of the petal, leaf, or fruit, is destroyed, it is not again regenerated, nor is the wound healed up, except by means of a scar. Such is the case also with all decortications that penetrate deeper than the epidermis, particularly if the wound is not protected from the action of the air: if the decortication reaches to the wood, then new bark issues from between the bark and wood, and spreads till it covers the wound. But the result is not the same when the wound is covered from the air. In the season of the flowing of the sap Du Hamel detached a ring of bark, of three or four inches in breadth, from the trunks of several young elm-trees,

taking care to defend the decorticated part from the action of the air, by surrounding it with a tube of glass cemented above and below to the trunk. After a few days the tubes became cloudy within, particularly when it was hot; but when the air became cool, the cloud condensed and fell in drops to the bottom. At last there began to appear, as if exuding from between the bark and wood of the upper part of the wound, a sort of rough scurfy substance; and on the surface of the wood, as if exuding from between the longitudinal fibres of the albumen, a number of gelatinous drops. They were not connected with the scurfy substance at the top, but seemed to arise from small slips of the liber that had not been completely detached. Their first appearance was that of small reddish spots changing by degrees into white, and finally into a sort of grey, and extending in size till they at last united and formed a cicatrice, which was a new bark.

1650. *Abortion or failure in the produce of flowers, fruits, or of perfect seeds,* is generally the effect of accidental injuries, either directly to the flower or fruit, by which they are rubbed off or devoured by insects; or to the leaves by insects; or to the roots by exposure to the air or cutting off so much of them as essentially to lessen their power of drawing up nourishment. Other causes will readily suggest themselves; and one of the commonest, as to seeds and fruits, is want of sufficient impregnation.

1651. *Premature inflorescence or fruiting* is sometimes brought on by insects, but more generally by checks produced by cold or injuries from excessive heat, or long continued drought. Fruit is often ripened prematurely by the puncture of insects; and a pine-apple plant of almost any age may be thrown into fruit by an hour or two's exposure to a frosty atmosphere in winter, or by scorching the roots in an over-hot tan-bed at any season.

## SECT. II. Diseases.

1652. *Diseases* are corrupt affections of the vegetable body, arising from a vitiated state of its juices, and tending to injure the habitual health either of the whole or part of the plant. The diseases that occur the most frequently among vegetables are the following: Blight, smut, mildew, honey-dew, dropsy, flux of juices, gangrene, etiolation, suffocation, contortion, consumption.

1653. *Blight.* Much has been written on the nature of blight; and in proportion as words have been multiplied on the subject, the difficulties attending its elucidation have increased.

1654. *The blight, or blast,* was well known to the ancient Greeks, who were however totally ignorant of its cause, regarding it merely as a blast from heaven, indicating the wrath of their offended deities, and utterly incapable of prevention or cure. It was known also to the Romans under the denomination of *rubigo*, who regarded it in the same light as the Greeks, and even believed it to be under the direction of a particular deity, Rubigus, whom they solemnly invoked that blight might be kept from corn and trees. It is still well known from its effects to every one having the least knowledge of husbandry or gardening; but it has been very differently accounted for. And, perhaps, there is no one cause that will account for all the different cases of blight, or disease going by the name of blight; though they have been supposed to have all the same origin. If we take the term in its most general acceptation I think it will include at least three distinct species—blight originating in cold and frosty winds, blight originating in a sort of sultry and pestilential vapor, and blight originating in the immoderate propagation of a sort of small and parasitical fungus.

1655. *Blight, originating in cold and frosty winds,* is often occasioned by the cold and easterly winds of spring, which nip and destroy the tender shoots of the plant, by stopping the current of the juices. The leaves which are thus deprived of their due nourishment wither and fall, and the juices that are now stopped in their passage swell and burst the vessels, and become the food of innumerable little insects that soon after make their appearance. Hence they are often mistaken for the cause of the disease itself; the farmer supposing they are wafted to him on the east wind, while they are only generated in the extravasated juices, as forming a proper nidus for their eggs. Their multiplication will no doubt contribute to the spreading of the disorder, as they always breed fast where they find plenty of food. But a similar disease is often occasioned by the early frost of spring. If the weather is prematurely mild, the blossom is prematurely protruded, which, though it is viewed by the unexperienced with delight, yet it is viewed by the judicious with fear. For it very often happens that this premature blossom is totally destroyed by subsequent frosts, as well as both the leaves and shoots, which consequently wither and fall, and injure if they do not actually kill the plant. This evil is also often augmented by the unskillful gardener, even in attempting to prevent it; that is, by matting up his trees too closely, or by keeping them covered in the course of the day, and thus rendering the shoots so tender that they can scarcely fail to be destroyed by the next frost.

1656. *Blight, originating in sultry and pestilential vapor,* generally happens in the summer when the grain has attained to its full growth, and when there are no cold winds or frosts to occasion it. Such was the blight that used to damage the vineyards of ancient Italy, and which is yet found to damage our hop-plantations and wheat-crops. The Romans had observed that it generally happened after short but heavy showers occurring about noon, and followed by clear sunshine, about the season of the ripening of the grapes, and that the middle of the vineyard suffered the most. This corresponds pretty nearly to what is in this country called the fire-blast among hops, which has been observed to take place, most commonly about the end of July, when there has been rain with a hot gleam of sunshine immediately after; the middle of the hop-ground is also the most affected whether the blight is general or partial, and is almost always the point in which it originates. In a particular case that was minutely observed, the damage happened a little before noon, and the blight ran in a line forming a right angle with the sunbeams at that time of the day. There was but little wind, which was however in the line of the blight. (*Hale's Body of Husbandry.*) Wheat is also affected with a similar sort of blight, and about the same season of the year, which totally destroys the crop. In the summer of 1809, a field of wheat, on rather a light and sandy soil, came up with every appearance of health, and also into ear with a fair prospect of ripening well. About the beginning of July it was considered as exceeding any thing expected from such a soil. A week afterwards a portion of the crop, on the east side of the field, to the extent of several acres, was totally destroyed; being shrunk and shrivelled up to less than one half the size of what it had formerly been, and so withered and blasted as not to appear to belong to the same field. The rest of the field produced a fair crop.

1657. *Blight, originating in fungi,* attacks the leaves or stem both of herbaceous and woody plants, such as euphorbia cyparissias, berberis vulgaris and rhamnus catharticus, but more generally grasses; and particularly our most useful grains, wheat, barley, and oats. It generally assumes the appearance of a rusty-looking powder that soils the finger when touched. In March 1807, some blades of wheat were examined by Keith that were attacked with this species of blight; the appearance was that of a number of dorsiferous spots or patches dispersed over the surface of the leaf, exactly like that of the seeds of dorsiferous ferns bursting their indusium. Upon more minute inspection these patches were found to consist of thousands of small globules collected into groups beneath the epidermis, which they raised up in a sort of blister and at last burst. Some of the globules seemed as if imbedded even in the longitudinal vessels of the blade. They were of a yellowish or rusty brown, and somewhat transparent. But these groups of globules have been ascertained by Sir J. Banks to be patches of a minute fungus, the seeds of

which, as they float in the air, enter the pores of the epidermis of the leaf, particularly if the plant is sickly; or they exist in the manure or soil, and enter by the pores of the root. (*Sir J. Banks on Blight*, 1805.) This fungus has been figured by Sowerby, and by F. Bauer, and Grew. It is known among farmers by the name of reel rust, and as it affects the stalks and leaves only it does not materially which the crop. But there is another species of fungus known to the farmer by the name of red gum, injure attacks the ear only, and is extremely prejudicial. In the aggregate it consists of groups of minute globules interspersed with transparent fibres. The globules are filled with a fine powder, which explodes when they are put into water. It is very generally accompanied with a maggot of a yellow colour, that preys also upon the grain, and increases the amount of injury. The only means of preventing or lessening the effect of any of the different varieties of blight mentioned is proper culture. Palliatives are to be found in topical applications, such as flower of sulphur, and where the disease proceeds from, or consists of, innumerable minute insects, it may occasionally be removed. Grisenthwaite conjectures that in many cases in which the blight and mildew attack corn-crops, it may be for want of the peculiar food requisite for perfecting the grain; it being known that the fruit or seeds of many plants contain primitive principles not found in the rest of the plant. Thus the grain of wheat contains gluten and phosphate of lime, and where these are wanting in the soil, that is, in the manured earths in which the plant grows, it will be unable to perfect its fruit, which of consequence becomes more liable to disease. (*New Theory of Agr. &c.*)

1658. *Smut* is a disease incidental to cultivated corn, by which the farina of the grain, together with its proper integuments and even part of the husk, is converted into a black soot-like powder. If the injured ear is struck with the finger, the powder will be dispersed like a cloud of black smoke; and if a portion of the powder is wetted by a drop of water and put under the microscope, it will be found to consist of millions of minute and transparent globules, which seem to be composed of a clear and glary fluid encompassed by a thin and skinny membrane. This disease does not affect the whole body of the crop, but the smutted ears are sometimes very numerous dispersed throughout it. Some have attributed it to the soil in which the grain is sown, and others have attributed it to the seed itself, alleging that smutted seed will produce a smutted crop. But in all this there seems to be a great deal of doubt. Willdenow regards it as originating in a small fungus, which multiplies and extends till it occupies the whole ear. (*Princip. of Bot.* p. 356.) But F. Bauer of Kew, seems to have ascertained it to be merely a morbid swelling of the ear, and not at all connected with the growth of a fungus. (*Smith's Introd.* p. 348.) It is said to be prevented by steeping the grain before sowing in a weak solution of arsenic. But besides the disease called smut there is also a disease analogous to it, or a different stage of the same disease, known to the farmer by the name of bags or smut-balls, in which the nucleus of the seed only is converted into a black powder, whilst the ovary, as well as the husk, remains sound. The ear is not much altered in its external appearance, and the diseased grain contained in it will even bear the operation of threshing, and consequently mingle with the bulk. But it is always readily detected by the experienced buyer, and fatal to the character of the sample. It is said to be prevented as in the case of smut.

1659. *Mildew* is a thin and whitish coating with which the leaves of vegetables are sometimes covered, occasioning their decay and death, and injuring the health of the plant. It is frequently found on the leaves of tussilago farfara, humulus lupulus, corylus avellana, and the white and yellow dead-nettle. It is found also on wheat in the shape of a glutinous exudation, particularly when the days are hot and the nights without dew. Willdenow says it is occasioned by the growth of a fungus of great minuteness, the mucor erisyphe of Linnæus; or by a sort of whitish slime which some species of aphides deposit upon the leaves. J. Robertson (*Hort. Trans.* v. 178.) considers it as a minute fungus of which different species attack different plants. Sulphur he has found the only specific cure. In cultivated crops mildew is said to be prevented by manuring with soot.

1660. *Honey-dew* is a sweet and clammy substance which coagulates on the surface of the leaves during hot weather, particularly on the leaves of the oak-tree and beech, and is regarded by Curtis, as being merely the dung of some species of aphides. This seems to be the opinion of Willdenow also, and it is no doubt possible that it may be the case in some instances or species of the disease. But Sir J. E. Smith contends that it is not always so, or that there are more species of honey-dew than one, regarding it particularly as being an exudation, at least in the case of the beech, whose leaves are, in consequence of an unfavorable wind, apt to become covered with a sweet sort of glutinous coating, similar in flavor to the fluid obtained from the trunk.

1661. It is certain, however, that *saccharine exudations are found on the leaves of many plants*, though not always distinguished by the name of honey-dew; which should not perhaps be applied except when the exudation occasions disease. But if it is to be applied to all saccharine exudations whatever, then we must include under the appellation of honey-dew, the saccharine exudations observed on the orange-tree by De la Hire, together with that of the lime-tree which is more glutinous, and of the poplar which is more resinous; as also that of the cistus creticus, and of the manna which exudes from the ash-tree of Italy and larch of France. It is also possible that the exudation or excrement constituting honey-dew may occasionally occur without producing disease; for if it should happen to be washed off soon after by rains or heavy dews, then the leaves will not suffer. Washing is therefore the palliative: judicious culture the preventive.

1662. *Dropsy*. Plants are also liable to a disease which affects them in a manner similar to that of the dropsy in animals, arising from long continued rain or too abundant watering.



Willdenow describes it as occasioning a preternatural swelling of particular parts, and inducing putrefaction. It is said to take place chiefly in bulbous and tuberous roots; which are often found much swelled after rain. It affects fruits also, which it renders watery and insipid. It prevents the ripening of seeds, and occasions an immoderate production of roots from the stem.

1633. *Succulent plants.* This disease generally appears in consequence of excessive waterings, and is generally incurable. The leaves drop, even though plump and green; and the fruit rots before reaching maturity. In this case the absorption seems to be too great in proportion to the transpiration; but the soil when too much manured produces similar effects. Du Hamel planted some elms in a soil that was particularly well manured, and accordingly they pushed with great vigor for some time; but at the end of five or six years they all died suddenly. The bark was found to be detached from the wood, and the cavity filled up with a reddish-colored water. The symptoms of this disease suggest the palliatives; and the preventive is ever the same — judicious culture.

1664. *Flux of juices.* Some trees, but particularly the oak and birch, are liable to a great loss of sap either bursting out spontaneously, owing to a superabundance of sap, or issuing from accidental wounds; sometimes it is injurious to the health of the plant, and sometimes not.

1665. There is a *spontaneous extravasation* of the sap of the vine, known by the name of the tears of the vine, which is not always injurious. As it often happens that the root imbibes sap, which the leaves are not yet prepared to throw off, because not yet sufficiently expanded, owing to an inclement season, the sap which is first carried up, being propelled by that which follows, ultimately forces its way through all obstructions, and exudes from the bud. But this is observed only in cold climates; for in hot climates where the development of the leaves is not obstructed by cold, they are ready to elaborate the sap as soon as it reaches them. There is also a spontaneous extravasation of proper juice in some trees, which does not seem in general to be injurious to the individual. Thus the gum which exudes from cherry, plum, peach, and almond trees, is seldom detrimental to their health, except when it insinuates itself into the other vessels of the plant and occasions obstructions.

1666. But the *exudation of gum* is sometimes a disease, and one for which there is seldom any remedy. It is generally the consequence of an unsuitable soil, situation, or climate. Cold raw summers will produce it in the peach, apricot, and more under-sorts of plum and cherry; or grafting these fruits on diseased stocks. Cutting out the part and applying a covering of loam or tar and charcoal to exclude the air are palliatives; but the only effectual method, where it can be practised, is to take up the tree and place it in a suitable soil and situation.

1667. *The extravasation and corruption* of the ascending or descending juices, has been known to occasion a fissure of the solid parts. Sometimes the fissure is occasioned by means of frost, forming what is called a double albumen; that is, first a layer that has been injured by the frost, and then a layer that passes into wood. Sometimes a layer is partially affected, and that is generally owing to a sudden and partial thaw on the south side of the trunk, which may be followed again by a sudden frost. In this case the albumen is split into clefts or chinks, by means of the expansion of the frozen sap.

1668. *Chilblains.* But clefts thus occasioned often degenerate into chilblains that discharge a blackish and acrid fluid to the great detriment of the plant, particularly if the sores are so situated that rain or snow will readily lodge in them, and become putrid. The same injury may be occasioned by the bite or puncture of insects while the shoot is yet tender; and as no vegetable ulcer heals up of its own accord, the sooner a cure is attempted the better, as it will, if left to itself, ultimately corrode and destroy the whole plant, bark, wood, and pith. The only palliative is the excision of the part affected, and the application of a coat of grafting wax. (*Willdenow*, p. 354.)

1669. *Gangrene.* Of this disorder there are two varieties, the dry and the wet. The former is occasioned by means of excessive heat or excessive cold. If by means of cold, it attacks the leaves of young shoots and causes them to shrink up, converting them from green to black; as also the inner bark, which it blackens in the same manner, so that it is impossible to save the plant except by cutting it to the ground. If by means of heat, the effects are nearly similar, as may oftentimes be seen in gardens, or even in forests, where the foresters are allowed to clear away the moss and withered leaves from the roots. Sometimes the disease is occasioned by the too rapid growth of a particular branch, depriving the one that is next it of its due nourishment, and hence inducing its decay. Sometimes it is occasioned by means of parasitical plants, as in the case of the bulbs of the saffron, which a species of lycoperdon often attaches itself to and totally corrupts.

1670. *Dry gangrene.* The harmattan winds of the coast of Africa kill many plants, by means of inducing a sort of gangrene that withers and blackens the leaves, and finally destroys the whole plant. The nopal of Mexico is also subject to a sort of gangrene that begins with a black spot, and extends till the whole leaf or branch rots off, or the plant dies. But plants are sometimes affected with a gangrene by which a part becomes first soft and moist, and then dissolves into foul ichor. This is confined chiefly to the leaves, flowers, and fruit. Sometimes it attacks the roots also, but rarely the stem. It seems to be owing, in many cases, to too wet or too rich a soil; but it may originate in contusion, and may be caught by infection. But the nopal is subject also to a disease called by Thiery, *la dissolution*, considered by Sir J. E. Smith as distinct from gangrene, and which appears to be Willdenow's dry gangrene. A joint of the nopal, or a whole branch, and sometimes an entire plant, changes in the space of a single hour, from a state of apparent health to a state of putrefaction or dissolution. Now its surface is verdant and shining, and in an instant it changes to a yellow, and its brilliancy is gone. If the substance is cut into, the parts are found to have lost all cohesion, and are quite rotten; the attempt at a cure is by speedy amputation below the diseased part. Sometimes the vital principle collecting and exerting all its energies, makes a stand as it were against the encroaching disease, and throws off the infected part. (*Smith's Introduction*, p. 340.)

1671. *Etiolation.* Plants are sometimes affected by a disease which entirely destroys their verdure, and renders them pale and sickly. This is called *etiolation*, and may arise merely from want of the agency of light, by which the extrication of oxygen is effected, and the leaf rendered green. And hence it is that plants placed in dark rooms, or between great masses of stone, or in the clefts of rocks, or under the shade of other trees,

look always peculiarly pale. But if they are removed from such situations, and exposed to the action of light, they will again recover their green color. Etiolation may also ensue from the depredation of insects nesting in the radicle, and consuming the food of the plant, and thus debilitating the vessels of the leaf so as to render them insusceptible of the action of light. This is said to be often the case with the radicles of *secale cereale*; and the same result may also arise from poverty of soil.

1672. *Suffocation*. Sometimes it happens that the pores of the epidermis are closed up, and transpiration consequently obstructed, by means of some extraneous substance that attaches itself to and covers the bark. This obstruction induces disease, and the disease is called *suffocation*.

1673. Sometimes it is occasioned by the immoderate growth of lichens upon the bark covering the whole of the plant, as may be often seen in fruit-trees, which it is necessary to keep clean by means of scraping off the lichens, at least from the smaller branches. For if the young branches are thus coated, so as that the bark cannot perform its proper functions, the tree will soon begin to languish, and will finally become covered with fungi, inducing or resulting from decay, till it is at last wholly choked up.

1674. But a similar effect is also occasionally produced by insects, in feeding upon the sap or shoot. This may be exemplified in the case of the aphids, which sometimes breed or settle upon the tender shoot in such multitudes as to cover it from the action of the external air altogether. It may be exemplified also in the case of *Coccus Hesperidum* and *Acarus telarius*, insects that infest hot-house plants, the latter by spinning a fine and delicate web over the leaf, and thus preventing the access of atmospheric air. Insects are to be removed either by the hand or other mechanical means, or destroyed by excess of some of the elements of their nutrition, as heat, or cold, or moisture, where such excess does not prove injurious to the plant; or by a composition either fluid or otherwise, which shall have the same effects. Prevention is to be attempted by general culture, and particular attention to prevent the propagation of the insects or vermin, by destroying their embryo progeny, whether oviparous or otherwise.

1675. Sometimes the disease is occasioned by an extravasation of juices which coagulate on the surface of the stalk so as to form a sort of crust, investing it as a sheath, and preventing its further expansion.

1676. Sometimes the disease is occasioned from want of an adequate supply of nourishment as derived from the soil, in which the lower part of the plant is the best supplied, while the upper part of it is starved. Hence the top shoots decrease in size every succeeding year, because sufficient supply of sap cannot be obtained to give them their proper development. This is analogous to the phenomena of animal life, when the action of the heart is too feeble to propel the blood through the whole of the system: for then the extremities are always the first to suffer. And perhaps it may account also for the fact, that in bad soils and unfavorable seasons, when the ear of barley is not wholly perfected, yet a few of the lower grains are always completely developed. (*Smith's Introduction*, p. 344.)

1677. *Contortion*. The leaves of plants are often injured by means of the puncture of insects, so as to induce a sort of disease that discovers itself in the contortion or convolution of the margin, or wrinkled appearance of the surface. The leaves of the apricot, peach, and nectarine, are extremely liable to be thus affected in the months of June and July.

1678. *The leaf* that has been punctured soon begins to assume a rough and wrinkled figure, and a reddish and scrofulous appearance, particularly on the upper surface. The margins roll inwards on the under side, and enclose the eggs which are scattered irregularly on the surface, giving it a blackish and granular appearance, but without materially injuring its health. In the vine, the substance deposited on the leaf is whitish, giving the under surface a sort of a frosted appearance, but not occasioning the red and scrofulous aspect of the upper surface of the leaf of the nectarine. In the poplar, the eggs when first deposited resemble a number of small and hoary vesicles containing a sort of clear and colorless fluid. The leaf then becomes reflected and conduplicated, enclosing the eggs, with a few reddish protuberances on the upper surface. The embryo is nourished by this fluid; and the hoariness is converted into a fine cottony down, which for some time envelopes the young fly. The leaf of the lime-tree in particular is liable to attacks from insects when fully expanded; and hence the gnawed appearance it so often exhibits. The injury seems to be occasioned by some species of puceron depositing its eggs in the parenchyma, generally about the angles that branch off from the midrib. A sort of down is produced, at first green, and afterwards hoary; sometimes in patches, and sometimes pervading the whole leaf; as in the case of the vine. Under this covering the egg is hatched; and then the young insect gnaws and injures the leaf, leaving a hole, or scar of a burnt or singed appearance. Sometimes the upper surface of the leaf is covered with clusters of wart-like substances somewhat subulate and acute. They seem to be occasioned by means of a puncture made on the under surface, on which a number of openings are discoverable, penetrating into the warts, which are hollow and villous within. The disease admits of palliation by watering frequently over the leaves; and by removing such as are the most contorted and covered by larvæ.

1679. *Consumption*. From barren or improper soil, unfavorable climes, careless planting, or too frequent flowering exhausting the strength of the plant, it often happens that disease is induced which terminates in a gradual decline and wasting away of the plant, till at length it is wholly dried up. Sometimes it is also occasioned by excessive drought, or by dust lodging on the leaves, or by fumes issuing from manufactories which may happen to be situated in the neighborhood, or by the attacks of insects.

1680. There is a *consumptive affection* that frequently attacks the pine-tree, called *Teredo Pinorum* (*Willdenow, Princ. Bot.* p. 351.), which affects the alburnum and inner bark chiefly, and seems to proceed from long continued drought, or from frost suddenly succeeding mild or warm weather, or heavy winds. The leaves assume a tinge of yellow, bordering upon red. A great number of small drops of resin exude from the middle of the boughs, of a putrid odor. The bark exfoliates, and the alburnum presents a livid appearance. The tree swarms with insects, and the disease is incurable, inducing inevitably the total decay and death of the individual. The preventive is obviously good culture, so as to maintain vigorous health: palliatives may be employed according to the apparent cause of the disease.

### SECT. III. *Natural Decay.*

1681. Although a plant should not suffer from the influence of accidental injury, or from disease, still there will come a time when its several organs will begin to experience the approaches of a *natural decline* insensibly stealing upon it, and at last inducing death. The duration of vegetable existence is very different in different species. Yet in the vegetable, as well as in the animal kingdom, there is a term or limit set, beyond which

the individual cannot pass. Some plants are annuals and last for one season only, springing up suddenly from seed, attaining rapidly to maturity, producing and again sowing their seeds, and afterwards immediately perishing. Such is the character of the various species of corn, as exemplified in oats, wheat, and barley. Some plants continue to live for a period of two years, and are therefore called biennials, springing up the first year from seed, and producing roots and leaves, but no fruit; and in the second year producing both flower and fruit, as exemplified in the carrot, parsnep, and caraway. Other plants are perennials, that is, lasting for many years; of which some are called under-shrubs, and die down to the root every year; others are called shrubs, and are permanent both by the root and stem, but do not attain to a great height or great age; others are called trees, and are not only permanent by both root and stem, but attain to a great size, and live to a great age. But even of plants that are woody and perennial, there are parts which perish annually, or which are at least annually separated from the individual; namely, the leaves, flowers, and fruit, leaving nothing behind but the bare caudex, which submits in its turn to the ravages of time, and ultimately to death.

1682. *The decay of the temporary organs*, which takes place annually, is a phenomenon familiar to every body, and comprehends the fall of the leaf, the fall of the flower, and the fall of the fruit.

1683. *The fall of the leaf*, or annual defoliation of the plant, commences for the most part with the colds of autumn, and is accelerated by the frosts of winter, that strip the forest of its foliage, and the landscape of its verdure. But there are some trees that retain their leaves throughout the whole of the winter, though changed to a dull and dusky brown, and may be called *ever-clothed* trees, as the beech: and there are others that retain their verdure throughout the year, and are denominated evergreens, as the holly. The leaves of both sorts ultimately fall in the spring. Sir J. E. Smith considers that leaves are thrown off by a process similar to that of the sloughing of diseased parts in the animal economy; and Keith observes, that if it is necessary to illustrate the fall of the leaf by any analogous process in the animal economy, it may be compared to that of the shedding of the antlers of the stag, or of the hair or feathers of other beasts or birds, which being, like the leaves of plants, distinct and peculiar organs, fall off, and are regenerated annually, but do not slough.

1684. *The flowers*, which, like the leaves, are only temporary organs, are for the most part very short-lived; for as the object of their production is merely that of effecting the impregnation of the germs, that object is no sooner obtained than they begin again to give indications of decay, and speedily fall from the plant; so that the most beautiful part of the vegetable is also the most transient.

1685. *The fruit*, which begins to appear conspicuous when the flower falls, expands and increases in volume, and, assuming a peculiar hue as it ripens, ultimately detaches itself from the parent plant, and drops into the soil. But it does not in all cases detach itself in the same manner: thus, in the bean and pea the seed-vessel opens and lets the seeds fall out, while in the apple, pear, and cherry, the fruit falls entire, enclosing the seed, which escapes when the pericarp decays. Most fruits fall soon after ripening, as the cherry and apricot, if not gathered; but some remain long attached to the parent plant after being fully ripe, as in the case of the fruit of *eunymus*, and *mespilus*. But these, though tenacious of their hold, detach themselves at last, as well as all others, and bury themselves in the soil, about to give birth to a new individual in the germination of the seed. The fall of the flower and fruit is accounted for in the same manner as that of the leaf.

1686. *Decay of the permanent organs*. Such then is the process and presumptive rationale of the decay and detachment of the temporary organs of the plant. But there is also a period beyond which even the permanent organs themselves can no longer carry on the process of vegetation. Plants are affected by the infirmities of old age as well as animals, and are found to exhibit also similar symptoms of approaching dissolution. The root refuses to imbibe the nourishment afforded by the soil, or if it does imbibe a portion, it is but feebly propelled, and partially distributed, through the tubes of the albumum; the elaboration of the sap is now effected with difficulty as well as the assimilation of the proper juice, the descent of which is almost totally obstructed; the bark becomes thick and woody, and covered with moss or lichens; the shoot becomes stunted and diminutive; and the fruits palpably degenerate, both in quantity and quality. The smaller or terminal branches fade and decay the first, and then the larger branches also, together with the trunk and root; the vital principle gradually declines without any chance of recovery, and is at last totally extinguished. "When life is extinguished, nature hastens the decomposition; the surface of the tree is overrun with lichens and mosses, which attract and retain the moisture; the empty pores imbibe it, and putrefaction speedily follows. Then come the tribes of fungi, which flourish on decaying wood, and accelerate its corruption; beetles and caterpillars take up their abode under the bark, and bore innumerable holes in the timber; and woodpeckers in search of insects pierce it more deeply, and excavate large hollows, in which they place their nests. Frost, rain, and heat assist, and the whole mass crumbles away, and dissolves into a rich mould." (*Dial. on Bot.* p. 365.)

## CHAP. VI.

*Vegetable Geography and History, or the Distribution of Vegetables relatively to the Earth and to Man.*

1687. *The science of the distribution of plants*, Humboldt observes (*Essai sur la Geographic des Plantes*, &c. 1807), considers vegetables in relation to their local associations in

different climates. It points out the grand features of the immense extent which plants occupy, from the regions of perpetual snow to the bottom of the ocean, and to the interior of the globe, where, in obscure grottoes, cryptogamous plants vegetate, as unknown as the insects which they nourish. The superior limits of vegetation are known, but not the inferior; for every where in the bowels of the earth are germs which develop themselves when they find a space and nourishment suitable for vegetation. On taking a general view of the disposition of vegetables on the surface of the globe, independently of the influence of man, that disposition appears to be determined by two sorts of causes, *geographical* and *physical*. The influence of man, or of cultivation, has introduced a third cause, which may be called *civil*. The different aspects of plants, in different regions, has given rise to what may be called their *characteristic* or *picturesque distribution*; and the subject of distribution may be also considered relatively to the *systematic* divisions of vegetables, their *arithmetical* proportions, and economical applications.

#### SECT. I. *Geographical Distribution of Vegetables.*

1688. *The territorial limits to vegetation* are determined in general by three different causes:—1. By sandy deserts, which seeds cannot pass over either by means of winds or birds, as that of Sahara, in Africa; 2. By seas too vast for the seeds of plants to be drifted from one shore to the other, as in the ocean; while the Mediterranean sea, on the contrary, exhibits the same vegetation on both shores; and, 3. By long and lofty chains of mountains. To these causes are to be attributed the fact, that similar climates and soils do not always produce similar plants. Thus in certain parts of North America, which altogether resemble Europe in respect to soil, climate, and elevation, not a single European plant is to be found. The same remark will apply to New Holland, the Cape of Good Hope, Senegal, and other countries, as compared with countries in similar physical circumstances, but geographically different. The separation of Africa and South America, Humboldt considers, must have taken place before the development of organised beings, since scarcely a single plant of the one country is to be found in a wild state in the other.

#### SECT. II. *Physical Distribution of Vegetables.*

1689. *The natural circumstances* affecting the distribution of plants, may be considered in respect to temperature, elevation, moisture, soil, and light.

1690. *Temperature* has the most obvious influence on vegetation. Every one knows that the plants of hot countries cannot in general live in such as are cold, and the contrary. The wheat and barley of Europe will not grow within the tropics; the same remark applies to plants of still higher latitudes, such as those within the polar circles, which cannot be made to vegetate in more southern latitudes; nor can the plants of more southern latitudes be made to vegetate there. In this respect, not only the medium temperature of a country ought to be studied, but the temperature of different seasons, and especially of winter. Countries where it never freezes; those where it never freezes so strong as to stagnate the sap in the stems of plants; and those where it freezes sufficiently strong to penetrate into the cellular tissue; form three classes of regions in which vegetation ought to differ. But this difference is somewhat modified by the effect of vegetable structure, which resists, in different degrees, the action of frost; thus, in general, trees which lose their leaves during winter resist the cold better than such as retain them; resinous trees more easily than such as are not so; herbs of which the shoots are annual and the root perennial, better than those where the stems and leaves are persisting; annuals which flower early, and whose seeds drop and germinate before winter, resist cold less easily than such as flower late, and whose seeds lie dormant in the soil till spring. Monocotyledonous trees, which have generally persisting leaves and a trunk without bark, as in palms, are less adapted to resist cold than dicotyledonous trees, which are more favorably organised for this purpose, not only by the nature of their proper juice, but by the disposition of the cortical and alburnous layers, and the habitual carbonisation of the outer bark. Plants of a dry nature resist cold better than such as are watery; all plants resist cold better in dry winters than in moist winters; and an attack of frost always does most injury in a moist country, in a humid season, or when the plant is too copiously supplied with water.

1691. Some plants of firm texture, but natives of warm climates, will endure a frost of a few hours' continuance, as the orange at Genoa, (*Humboldt, De Distributione Plantarum*); and the same thing is said of the palm and pine-apple, facts most important for the gardener. Plants of delicate texture, and natives of warm climates, are destroyed by the slightest attack of frost, as the phaseolus, nasturtium, &c.

1692. *The temperature of spring* has a material influence on the life of vegetables; the injurious effects of late frosts are known to every cultivator. In general, vegetation is favored in cold countries by exposing plants to the direct influence of the sun; but this excitement is injurious in a country subject to frosts late in the season; in such cases, it is better to retard than to accelerate vegetation.

1693. *The temperature of summer*, as it varies only by the intensity of heat, is not productive of so many injurious accidents as that of spring. Very hot dry summers, however, destroy many delicate plants, and especially those of cold climates. A very early summer is injurious to the germination and progress of seeds; a short summer to their ripening, and the contrary.

1694. *Autumn* is an important season for vegetation, as it respects the ripening of seeds; hence where that season is cold and humid, annual plants, which naturally flower late, are never abundant, as in the polar regions; the effect is less injurious to perennial plants, which generally flower earlier. Frosts early in autumn are as injurious as those which happen late in spring. The conclusion, from these considerations, obviously is, that temperate climates are more favorable to vegetation than such as are either extremely cold or extremely hot. But the warmer climates, as Keith observes, are more favorable upon the whole to vegetation than the colder, and that nearly in proportion to their distance from the equator. The same plants, however, will grow in the same degree of latitude, throughout all degrees of longitude, and also in correspondent latitudes on different sides of the equator; the same species of plants, as some of the palms and others, being found in Japan, India, Arabia, the West Indies, and part of South America, which are all in nearly the same latitudes; and the same species being also found in Kamschatka, Germany, Great Britain, and the coast of Labrador, which are all also in nearly the same latitudes. (*Willdenow*, p. 374.)

1695. *The most remarkable circumstances respecting the temperature in the three zones*, is exhibited in the following Table by Humboldt. The temperature is taken according to the centigrade thermometer. The fathom is 6 French feet, or 6,39453 English feet.

	Torrid zone.		Temperate zone.			Frigid zone.
	Andes of Quito, Lat. 0°.	Mountains of Mexico, Lat. 20°.	Caucasus, Lat. 42½°.	Pyrenees, Lat. 42½°.	Alps, Lat. 45¼° to 46°.	Lapland, Lat. 67° to 70°.
Inferior limit of perpetual snow - - }	2460 fa.	2350 fa.	1650 fa.	1400 fa.	1370 fa.	550 fa.
Mean annual heat at that height - - }	1½°.	—	—	3½°.	4°.	6°.
Mean heat of winter, do.	1½°.	—	—	—	10°.	20½°.
Mean heat of Aug. do.	1¾°.	—	—	—	6°.	9½°.
Distance between trees and snow - - }	600 fa.	350 fa.	650 fa.	230 fa.	450 fa.	300 fa.
Upper limit of trees -	1800 fa.	2000 fa.	1000 fa.	1170 fa.	920 fa.	250 fa.
Last species of trees towards the snow }	Escalonia alstonia.	Pinus occident.	Betula alba.	Pin. rubra P. uncin.	Pinus abies.	Betula alba.
Upper limit of the Ericineæ - - }	Befariae, 1600 fa)	—	Rhodod. Caucas. 1380 fa.	—	Rhodod. ferrug. 1170 fa.	Rhodod. laponic. 480 fa.
Distance between the snow and corn - }	800 fa.	—	630 fa.	—	700 fa.	450 fa.

1696. *Elevation*, or the height of the soil above the level of the sea, determines, in a very marked manner, the habitation of plants. The temperature lessens in regular gradation, in the same manner as it does in receding from the equator, and six hundred feet of elevation, De Candolle states, are deemed equal to one degree of latitude, and occasion a diminution of temperature equal to 23° of Fahrenheit; 300 feet being nearly equal to half a degree. Mountains 1000 fathoms in height, at 46° of latitude, have the mean temperature of Lapland; mountains of the same height between the tropics enjoy the temperature of Sicily; and the summits of the lofty mountains of the Andes, even where situated almost directly under the equator, are covered with snow as eternal as that of the north pole.

1697. Hence it is that *plants of high latitudes live on the mountains of such as are much lower*, and thus the plants of Greenland and Lapland are found on the Alps and Pyrenees. At the foot of Mount Ararat, Tournefort met with plants peculiar to Armenia; above these he met with plants which are found also in France; at a still greater height he found himself surrounded with such as grow in Sweden; and at the summit with such as vegetate in the polar regions. This accounts for the great variety of plants which are often found in a Flora of no great extent; and it may be laid down as a botanical axiom, that the more diversified the surface of the country, the richer will its Flora be, at least in the same latitudes. It accounts also, in some cases, for the want of correspondence between plants of different countries though placed in the same latitudes; because the mountains or ridges of mountains, which may be found in the one and not in the other, will produce the greatest possible difference in the character of their Floras. And to this cause may generally be ascribed the diversity that often actually exists between plants growing in the same latitudes, as between those of the north-west and north-east coasts of North America, as also of the south-west and south-east coasts; the former being more mountainous, the latter more flat. Sometimes the same sort of difference takes place between the plants of an island and those of the neighboring continent; that is, if the one is mountainous and the other flat; but if they are alike in their geographical delineation, then they are generally alike in their vegetable productions.

1698. *Cold and lofty situations are the favorite habitations of most cryptogamic plants of the terrestrial class, especially the fungi, algæ, and mosses*; as also of plants of the class *Tetradynamia*, and of the *Umbellatæ* and *Syngenesian* tribes; whereas trees and shrubs, ferns, parasitic plants, lilies, and aromatic plants, are most abundant in warm climates; only this is not to be understood merely of geographical climates, because, as we have seen, the physical climate depends upon altitude. In consequence of which, combined with the ridges and directions of the mountains, America and Asia are much colder in the same degrees of northern latitude than Europe. American plants, vegetating at forty-two degrees of northern latitude, will vegetate very well at fifty-two degrees in Europe; the same, or nearly so, may be said of Asia; which, in the former case, is perhaps owing to the immense tracts of woods and marshes covering the surface, and in the latter, to the more elevated and mountainous situation of the country affecting the degree of temperature. So also Africa is much hotter under the tropics than America; because in the latter the temperature is lowered by immense chains of mountains traversing the equatorial regions, while in the former it is increased by means of the hot and burning sands that cover the greater part of its surface.

1699. *Elevation influences the habits of plants in various ways*;—by exposing them to the wind; to be watered by a very fresh and pure water from the melting of adjoining snow; and to be covered in winter by a thick layer of snow, which protects them from severe frosts. Hence many alpine plants become frozen during winter in the plains, and in gardens which are naturally warmer than their natural stations. In great elevations, the diminution of the density of the air may also have some influence on vegetation. The rarity of the atmosphere admits a more free passage for the rays of light, which, being in consequence more active, ought to produce a more active vegetation. Experience seems to prove this in high mountains; and the same effect is produced in high latitudes by the length of the day. On the other hand, vegetables require to absorb a certain quantity of oxygen gas from the air during the night; and as they find less of that in the rarified air of the mountains, they ought to be proportionably feeble and languishing. According to experiments made by Theodore de Saussure, plants which grow best in the high Alps are those which require to absorb least oxygen during the night; and, in this point of view, the shortness of the nights near the poles correspond. These causes, however, are obviously very weak, compared to the powerful action of temperature.

1700. *Great anomalies are found in the comparative height in which the same plant will grow in different circumstances*. In countries situated under the equator, the two sides of the mountain are of the same temperature, which is solely determined by elevation; but in countries distant from it, the warmest side is that towards the south, and the zones of plants, instead of forming lines parallel to the horizon, incline towards the north. The reason, in both cases, is sufficiently obvious. In the temperate zone we find the same plants frequently on low and elevated situations, but this is never the case between the tropics.

1701. *Altitude influences the habits of aquatics*; thus some aquatics float always on the surface of the water, as lemna, while others are either partially or wholly immersed. Such aquatics as grow in the depths of the sea are not influenced by climate; but such as are near the surface are influenced by climate, and have their habitations affected by it.

1702. *The moisture, or mode of watering natural to vegetables, is a circumstance which has a powerful influence on the facility with which plants grow in any given soil*. The quantity of water absolutely necessary for the nourishment of plants, varies according to their tissue; some are immersed, others float on its surface; some grow on the margin

of waters, with their roots always moistened or soaked in it, others again live in soil slightly humid or almost dry. Vegetables which resist extreme drought most easily are, 1. Trees and herbs with deep roots, because they penetrate to, and derive sufficient moisture from, some distance below the surface; 2. Plants, which, being furnished with few pores on the epidermis, evaporate but little moisture from their surface, as the succulent tribe.

1703. *The qualities of water*, or the nature of the substances dissolved in it, must necessarily influence powerfully the possibility of certain plants growing in certain places. But the difference in this respect is much less than would be imagined, because the food of one species of plant differs very little from that of another. The most remarkable case is that of salt-marshes, in which a great many vegetables will not live, whilst a number of others thrive there better than any where else. Plants which grow in marine marshes, and those which grow in similar grounds situated in the interior of a country, are the same. Other substances naturally dissolved in water appear to have much less influence on vegetation, though the causes of the habitations of some plants, such as those which grow best on walls, as peltaria, and in lime-rubbish, as thlaspi, and other crucifera, may doubtless be traced to some salt (nitrate of lime, &c.) or other substance peculiar to such situations.

1704. *The nature of the earth's surface* affects the habitations of vegetables in different points of view: 1. As consisting of primitive earths, or the *débris* of rocks or mineral bodies; and, 2. As consisting of a mixture of mineral, animal, and vegetable matter.

1705. *Primitive surfaces* affect vegetables mechanically according to their different degrees of moveability or tenacity. In coarse sandy surfaces plants spring up easily, but many of them, which have large leaves or tall stems, are as easily blown about and destroyed. In fine, dry, sandy surfaces, plants with very delicate roots, as protea and erica, prosper; a similar earth, but moist in the growing season, is suited to bulbs. On clayey surfaces plants are more difficult to establish, but when established are more permanent: they are generally coarse, vigorous, and perennial in their duration.

1706. With respect to the *relative proportions of the primitive earths* in these surfaces, it does not appear that their influence on the distribution of plants is so great as might at first sight be imagined. Doubtless different earths are endowed with different degrees of absorbing, retaining, and parting with moisture and heat; and these circumstances have a material effect in a state of culture, where they are comminuted and exposed to the air: but not much in a wild or natural state, where they remain hard, firm, and covered with vegetation. The difference, with a few exceptions, is never so great but that the seeds of a plant which has been found to prosper well in one description of earth, will germinate and thrive as well in another composed of totally different earths, provided they are in a nearly similar state of mechanical division and moisture. Thus De Candolle observes, though the box is very common on calcareous surfaces, it is found in as great quantities in such as are schistous or granitic. The chestnut grows equally well in calcareous and clayey earths, in volcanic ashes, and in sand. The plants of Aira, a mountain entirely calcareous, grow equally well on the Vosges or the granitic Alps. But though the kind or mixture of earths seems of no great consequence, yet the presence of metallic oxides and salts, as sulphates of iron or copper, or sulphur alone, or alum, or other similar substances in a state to be soluble in water, are found to be injurious to all vegetation, of which some parts of Derbyshire and the *maremme* of Tuscany (*Chateauvieux*, let. 8.) are striking proofs. But excepting in these rare cases, plants grow nearly indifferently on all primitive surfaces, in the sense in which we here take these terms; the result of which is, that earths strictly or chemically so termed, have much less influence on the distribution of plants, than temperature, elevation, and moisture. Another result is, as De Candolle has well remarked, that it is often a very bad method of culture to imitate too exactly the nature of the earth in which a plant grows in its wild state.

1707. *Mixed or secondary soils* include not only primitive earths, or the *débris* of rocks, but vegetable matters — not only the medium through which perfect plants obtain their food, but that food itself. In this view of the subject the term soil is used in a very extensive acceptation, as signifying, not only the various sorts of earths which constitute the surface of the globe, but every substance whatever on which plants are found to vegetate, or from which they derive their nourishment. The obvious division of soils in this acceptation of the term is that of aquatic, terrestrial, and vegetable soils; corresponding to the division of aquatic, terrestrial, and parasitical plants.

1708. *Aquatic soils* are such as are either wholly or partially inundated with water, and are fitted to produce such plants only as are denominated aquatics. Of aquatics there are several subdivisions according to the particular situations they affect, or the degree of immersion they require.

1709. One of the principal subdivisions of aquatics is that of *marine plants*, such as the fuci and many of the *algæ*, which are very plentiful in the seas that wash the coasts of Great Britain, and are generally

attached to the stones and rocks near the shore. Some of them are always immersed; and others, which are situated above low water mark, are immersed and exposed to the action of the atmosphere alternately. But none of them can be made to vegetate except in the waters of the sea. Another subdivision of aquatics is that of *river plants*, such as chara, potamogeton, and nymphæa, which occupy the bed of fresh water rivers, and vegetate in the midst of the running stream; being for the most part wholly immersed, as well as found only in such situations.

1710. A third subdivision of aquatics is that of *paludal or fen plants*, being such as are peculiar to lakes, marshes, and stagnant or nearly stagnant waters, but of which the bottom is often tolerably clear. In such situations you find the *isœtis lacustris*, flowering rush, water ranunculus, water violet, and a variety of others which uniformly affect such situations; some of them being wholly immersed, and others immersed only in part.

1711. *Earthy soils* are such as emerge above the water and constitute the surface of the habitable globe, that is every where covered with vegetable productions. Plants affecting such soils, which comprise by far the greater part of the vegetable kingdom, are denominated *terrestrial*, being such as vegetate upon the surface of the earth, without having any portion immersed in water, or requiring any further moisture for their support beyond that which they derive from the earth and atmosphere. This division is, like the aquatics, distributed into several subdivisions according to the peculiar situations which different tribes affect.

1712. Some of them are *maritime*, that is, growing only on the sea-coast, or at no great distance from it, such as *statice*, *flaux*, *samolus*, *samphire*, *sea-pea*.

1713. Some are *fluvial*, that is, affecting the banks of rivers, such as *lythrum*, *lycopus*, *eupatorium*.

1714. Some are *champaign*, that is, affecting chiefly the plains, meadows, and cultivated fields, such as *cardamine*, *tragopogon*, *agrostemma*.

1715. Some are *dumose*, that is, growing in hedges and thickets, such as the *bramble*.

1716. Some are *ruderate*, that is, growing on rubbish, such as *senecio viscosus*.

1717. Some are *sylvatic*, that is, growing in woods or forests, such as *stachys sylvatica*, *angelica sylvestris*.

1718. And, finally, some are *alpine*, that is, growing on the summits of mountains, such as *poa alpina*, *epilobium alpinum*, and many of the mosses and lichens.

1719. *Vegetable soils* are such as are formed of vegetating or decayed plants themselves, to some of which the seeds of certain other plants are found to adhere, as being the only soil fitted to their germination and development. The plants springing from them are denominated *Parasitical*, as being plants that will vegetate neither in the water nor earth, but on certain other plants, to which they attach themselves by means of roots that penetrate the bark, and from the juices of which they do often, though not always, derive their support. This last circumstance constitutes the ground of a subdivision of parasitical plants, into such as adhere to the dead or inert parts of other plants, and such as adhere to living plants, and feed on their juices.

1720. In the first subdivision we may place *parasitical mosses*, *lichens*, and *fungi*, which are found as often, and in as great perfection on the stumps of rotten trees, and on rotten pales and stakes, as on trees that are yet vegetating; whence it is also plain that they do not derive their nourishment from the juices of the plants on which they grow, but from their decayed parts, and the atmosphere by which they are surrounded; the plant to which they cling serving as a basis of support.

1721. In the second subdivision we may place all *plants strictly parasitical*, that is, all such as do actually abstract from the juices of the plant to which they cling the nourishment necessary to the development of their parts; and of which the most common, at least as being indigenous to Britain, are the *mistletoe*, *dodder*, *broom-rape*, and a sort of tuber that grows on the root of saffron, and destroys it if allowed to spread.

1722. *The mistletoe (Viscum album)* is found for the most part on the apple-tree; but sometimes also on the oak. If its berry is made to adhere to the trunk or branch of either of the foregoing trees, which from its glutinous nature it may readily be made to do, it germinates by sending out a small globular body attached to a pedicle, which after it acquires a certain length bends towards the bark, whether above it or below it, into which it insinuates itself by means of a number of small fibres which it now protrudes, and by which it abstracts from the plant the nourishment necessary to its future development. When the root has thus fixed itself in the bark of the supporting tree, the stem of the parasite begins to ascend, at first smooth and tapering, and of a pale green colour, but finally protruding a multiplicity of branches and leaves. It seems to have been thought by some botanists that the roots of the mistletoe penetrate even into the wood, as well as through the bark. But the observations of Du Hamel show that this opinion is not well founded. The roots are, indeed, often found within the wood, which they thus seem to have penetrated by their own vegetating power. But the fact is, that they are merely covered by the additional layers of wood that have been formed since the fibres first insinuated themselves into the bark.

1723. *The Cuscuta europæa*, or *dodder* (fig. 242.), though it is to be accounted a truly parasitical plant in the issue, is yet not originally so. For the seed of this plant when it has fallen to the ground takes root originally by sending down its radicle into the soil and elevating its stem into the air. It is not yet, therefore, a parasitical plant. But the stem which is now elevated above the surface lays hold of the first plant it meets with, though it is particularly partial to hops and nettles, and twines itself around it, attaching itself by means of little parasitical roots at the points of contact, and finally detaching itself from the soil altogether by the decay of the original root, and becoming a truly parasitical plant. Withering describes the plant in his arrangement as being originally parasitical; but this is certainly not the fact.

1724. *The Orobanche*, or *broom-rape*, which attaches itself by the root to the roots of other plants, is also to be regarded as being truly parasitical, though it sometimes sends out fibres which seem to draw nourishment from the earth. It is found most frequently on the roots of clover and common broom.





1725. *The Epidendron flos acris* is regarded also by botanists as a parasitical plant, because it is generally found growing on other trees. But as it is found to grow in old tan, it probably derives only support from the bark of trees, and not nourishment.

1726. *Light* is a body which has very considerable influence on the structure of vegetables, and some also on their habitation. The fungi do not require the usual interludes of day, in order to decompose carbonic acid gas, and can live and thrive with little or no light. In green plants, which require the action of light, the intensity required is very different in different species; some require shady places, and hence the vegetable inhabitants of caves, and the plants which grow in the shades of forests; others, and the greater number, require the direct action of the sun, and grow in exposed elevated sites. De Candolle considers that the great difficulty of cultivating Alpine plants in the gardens of plains, arises from the impossibility of giving them at once the fresh temperature and intense light which they find on high mountains.

### SECT. III. *Civil Causes affecting the Distribution of Plants.*

1727. *By the art of man plants may be inured to circumstances foreign to their usual habits.* Though plants in general are limited to certain habitations destined for them by nature, yet some are, and probably the greater number may be, inured to climates, soils, and situations, of which they are not indigenous. The means used are acclimating and culture.

1728. *Acclimating* seems to be most easily effected in going from a hot to a cold climate particularly with herbaceous plants. Because it often happens that the frosts of winter are accompanied with snow, which shelters the plant from the inclemency of the atmosphere till the return of spring. Trees and shrubs, on the contrary, are acclimated with more difficulty, because they cannot be so easily sheltered from the colds, owing to the greater length of their stems and branches. The acclimating or naturalisation of vegetables is to be attempted by two modes: by sowing the seeds of successive generations, and by the difference of temperature produced by different aspects. The former is well exemplified in the case of the rice-plant which is grown in Germany, from seeds raised there, while if seeds from its native country, India, are used they will not vegetate (*Sir J. Banks, in Hort. Trans.* vol. i.); and the latter in the sloping banks of Professor Thouin of Paris, as described by Girardin. (*Physiologie Vegetale*, vol. i.) Some plants seem to have the capacity of vegetating in almost all climes, or of naturalising themselves in almost any. This is particularly the case with the domestic esculents, such as cabbages, potatoes, and carrots. (*Dialogues on Botany*, p. 411.)

1729. *Domesticated plants.* "Some plants," Humboldt observes "which constitute the object of gardening and of agriculture, have time out of mind accompanied man from one end of the globe to the other. In Europe, the vine followed the Greeks; the wheat, the Romans; and the cotton, the Arabs. In America the Tultiques carried with them the maize; and the potatoe and quinoa (*Chenopodium quinoa*, of which the seeds are used,) are found wherever have migrated the ancient Condinamarea. The migration of these plants is evident; but their first country is as little known as that of the different races of men, which have been found in all parts of the globe from the earliest traditions." (*Geographie des Plantes*, p. 25.)

1730. *The general effect of culture on plants* is that of enlarging all their parts; but it often also alters the qualities, forms, and colors: it never, however, alters their primitive structure. "The potatoe," as Humboldt observes, "cultivated in Chili, at nearly twelve thousand feet above the level of the sea, carries the same flower as in Siberia."

1731. *The culinary vegetables of our gardens*, compared with the same species in their wild state, afford striking proofs of the influence of culture on both the magnitude and qualities of plants. Nothing in regard to magnitude is more remarkable than in the case of the Brassica tribe; and nothing, in respect to quality, exceeds the change effected on the celery and carrot.

1732. *The influence of culture on fruits* is not less remarkable. The peach, in its wild state in Media, is poisonous, but cultivated in the plains of Ispahan and Egypt, it becomes one of the most delicious of fruits. The effect of culture on the apple, pear, cherry, plum, and other fruits, is nearly as remarkable; for not only the fruit and leaves, but the general habits of the tree, are altered in these and other species. The history of the migration of fruit-trees has been commenced by Sickler, in a work (*Geschichte, &c.*) which Humboldt has praised as equally curious and philosophical.

1733. *The influence of culture on plants of ornament* is great in most species. The parts of all plants are enlarged, some are numerically increased, as in the case of double flowers; and what is most remarkable, even the colors are frequently changed, both in the leaf, flower, and fruit.

1734. *The influence of civilisation and culture, in increasing the number of plants in a country*, is very considerable, and operates directly, by introducing new species for cul-

ture in gardens, fields, or timber-plantations; and indirectly by acclimating and final naturalisation of many species, by the influence of winds and birds in scattering their seeds. The vine and the fig are not indigenous to France, but are now naturalised there by birds. In like manner the orange is naturalised in the south of Italy. Many herbaceous plants of the Levant are naturalised both in France and Britain; some, as the cabbage, cherry, and apple, were probably naturalised during the subjection of England to the Romans. The narrow-leaved elm was brought from the Holy Land during the crusades. *Phaseolus vulgaris*, and *impatiens balsamina* were brought originally from India; and *datura stramonium*, which is now naturalised in Europe, was brought originally from India or Abyssinia. Buckwheat and most species of corn and peas came also from the East, and along with them several plants found among corn only, such as *centaurea cyanus*, *agrostemma githago*, *raphanus raphanistrum*, and *myagrum sativum*. The country from whence the most valuable grasses migrated is not known. Bruce says he found the oat wild in Abyssinia, and wheat and millet have been found in a wild state in hilly situations in the East Indies. Rye and the potatoe were not known to the Romans. The country of the former Humboldt declares to be totally unknown.

1735. *The greatest refinement in culture consists in the successful formation of artificial climates for the culture of tropical plants in cold regions.* Many vegetables, natives of the torrid zone, as the pine apple, the palm, &c. cannot be acclimated in temperate countries. But by means of hot-houses of different kinds they are grown even on the borders of the frozen zone to the highest degree of perfection; and in Britain some of the tropical fruits, as the pine and melon, are brought to a greater size and better flavor than in their native habitations. Casting our eyes on man, and the effects of his industry, we see him spread on the plains and sides of mountains, from the frozen ocean to the equator, and every where he wishes to assemble around him whatever is useful and agreeable of his own or of other countries. The more difficulties to surmount, the more rapidly are developed the moral faculties; and thus the civilisation of a people is almost always in an inverse ratio with the fertility of the soil which they inhabit. What is the reason of this? Humboldt asks. Habit and the love of the *site natal*.

#### SECT. IV. Characteristic or Picturesque Distribution of Vegetables.

1736. *The social and antisocial habits of plants is one of their most remarkable characteristics.* Like animals they live in two classes: the one class grows alone and scattered, as *solanum dulcamara*, *lychnis dioica*, *polygonum bistorta*, *anthericum liliago*, &c. The other class unites in society, like ants or bees, covers immense surfaces, and excludes other species, such as *fragaria vesca*, *vaccinium myrtillus*, *polygonum aviculare*, *aira canescens*, *pinus sylvestris*, &c. Barton states that the *mitchella repens* is the plant most extensively spread in North America, occupying all the ground between the 28° and 69° of north latitude. The *arbutus uva ursi*, extends from New Jersey to the 72° of latitude. On the contrary, *gordonia*, *franklinia*, and *dionæa muscipula* are found isolated in small spots. Associated plants are more common in the temperate zones than in the tropics, where vegetation is less uniform and more picturesque. In the temperate zones, the frequency of social plants, and the culture of man, has rendered the aspect of the country comparatively monotonous. Under the tropics, on the contrary, all sorts of forms are united; thus cypresses and pines are found in the forests of the Andes of Quindiu, and of Mexico; and bananas, palms, and bamboos in the valleys. (*fig. 243.*) But green meadows



243

and the season of spring are wanting in the south, for nature has reserved gifts for every region. "The valleys of the Andes," Humboldt observes, "are ornamented with bananas

and palms; on the mountains are found oaks, firs, barberries, alders, brambles, and a crowd of genera believed to belong only to countries of the north. Thus the inhabitant of the equinoctial regions views all the vegetable forms which nature has bestowed around him on the globe. Earth develops to his eyes a spectacle as varied as the azure vault of heaven, which conceals none of her constellations." The people of Europe do not enjoy the same advantage. The languishing plants, which the love of science or luxury cultivates in our hot-houses, present only the shadow of the majesty of equinoctial vegetation; but by the richness of our language, we paint these countries to the imagination, and individual man feels a happiness peculiar to civilization.

1737. *The features of many plants are so obvious and characteristic, as to strike every general observer. The scitamineæ, tree-heaths, firs, and pines, mimosæ, climbers, cacti, grasses, lichens, mosses, palms, equiseticæ, arums, pothos, dracontium, &c. the chaffy-leaved plants, malvaceæ, orchideæ, liliaceæ, &c. form remarkable groups distinguishable at first sight. Of these groups, the most beautiful are the palms, scitamineæ, and liliaceæ, which include the bamboos and plantains, the most splendid of umbrageous plants.*

1738. *The native countries of plants may often be discovered by their features in the same manner as the national distinctions which are observable in the looks and color of mankind, and which are effected chiefly by climate. Asiatic plants are remarkable for their superior beauty; African plants for their thick and succulent leaves, as in the case of the cacti; and American plants for the length and smoothness of their leaves, and for a sort of singularity in the shape of the flower and fruit. The flowers of European plants are but rarely beautiful, a great portion of them being amentaceous. Plants indigenous to polar and mountainous regions are generally low, with small compressed leaves; but with flowers large in proportion. Plants indigenous to New Holland are distinguishable for small and dry leaves, that have often a shrivelled appearance. In Arabia they are low and dwarfish; in the Archipelago they are generally shrubby and furnished with prickles; while in the Canary Islands many plants, which in other countries are merely herbs, assume the port of shrubs and trees. The shrubby plants of the Cape of Good Hope and New Holland exhibit a striking similarity, as also the shrubs and trees of the northern parts of Asia and America, which may be exemplified in the platanus orientalis of the former, and in platanus occidentalis of the latter, as well as in fagus sylvatica and fagus latifolia, or acer cappadocium and acer saccharinum; and yet the herbs and undershrubs of the two countries do not in the least correspond. "A tissue of fibres," Humboldt observes, "more or less loose — vegetable colors more or less vivid, according to the chemical mixture of their elements, and the force of the solar rays, are some of the causes which impress on the vegetables of each zone their characteristic features."*

1739. *The influence of the general aspect of vegetation on the taste and imagination of a people — the difference in this respect between the monotonous oak and pine forests of the temperate zones, and the picturesque assemblages of palms, mimosas, plantains, and bamboos of the tropics — the influence of the nourishment, more or less stimulant, peculiar to different zones, on the character and energy of the passions: — these, Humboldt observes, unite the history of plants with the moral and political history of man.*

#### SECT. V. *Systematic Distribution of Vegetables.*

1740. *The distribution of plants, considered in respect to their systematic classifications, is worthy of notice. The three grand systematic divisions of plants are acotyledoneæ, dicotyledoneæ, and monocotyledoneæ. A simplification of this division considers plants as agamous, or phanerogamous, that is, without or with visible sexes.*

1741. *Plants of visible sexes. Taking the globe in zones, the temperate contain  $\frac{1}{2}$  part of all the phanerogamous or visible sexual species of plants. The equinoctial countries contain nearly  $\frac{1}{30}$ , and Lapland only  $\frac{1}{30}$  part.*

1742. *Plants with the sexual parts invisible or indistinct. Taking the whole surface of the globe, the agamous plants, that is, mosses, fungi, fuci, &c. are to the phanerogamæ or perfect plants, nearly as 1 to 7; in the equinoctial countries as 1 to 5; in the temperate zones as 2 to 5; in New Holland as 2 to 11; in France as 1 to 2; in Lapland, Greenland, Iceland, and Scotland, they are as 1 to 1, or even more numerous than the phanerogamous plants. Within the tropics, agamous plants grow only on the summits of the highest mountains. In several of the islands of the Gulf of Carpentaria, having a Flora of phanerogamous plants exceeding 200 species, R. Brown did not observe a single moss.*

1743. *In the whole globe, the monocotyledoneæ, including the grasses, liliaceæ, scitamineæ, &c. are to the whole of the perfect plants as 1 to 6; in the temperate zones (between 36° and 52°) as 1 to 4; and in the polar regions as 1 to 20. In Germany, the monocotyledoneæ are to the total number of species as 1 to 4 $\frac{1}{2}$ ; in France as 1 to*

$\frac{4}{3}$ ; in New Holland the three grand divisions of plants, beginning with the acotyledonæ, are nearly as 1,  $2\frac{1}{2}$ , and  $7\frac{1}{4}$ .

1744. *Dicotyledonæ*. In the whole globe, the monocotyledonæ are estimated, by R. Brown, from Persoon's Synopsis, (*Gen. Rem. on the Bot. of Terr. Aust. 1814.*) to be to the dicotyledonæ as 2 to 11; or with the addition of undescribed plants, as 2 to 9. From the equator to  $30^\circ$  of north latitude, they are as 1 to 5. In the higher latitudes a gradual diminution of dicotyledonæ takes place, until in about  $60^\circ$  north latitude and  $50^\circ$  south latitude they scarcely equal half their intertropical proportions. The ferns in the temperate regions are to the whole number of species as 1, 2, and 5; that is, in the polar regions as 1, in the temperate countries as 2, and in the intertropical regions as 5. In France, ferns form  $\frac{1}{3}$  part of the phanerogamous plants; in Germany  $\frac{1}{43}$ ; in Lapland  $\frac{1}{26}$ .

1745. *The natural orders of perfect or phanerogamous plants are variously distributed in different countries.* The following Table gives a general view of the relative proportions of several natural orders of perfect plants in France, Germany, and Lapland.

Names of Natural Orders.	Number of Species in different Countries.			Ratio of each Family to the whole of the Phanerogamous plants in these Countries.		
	Fran.	Germ.	Lapl.	Fran.	Germ.	Lapl.
Cyperoideæ - - -	134	102	55	$\frac{1}{27}$	$\frac{1}{18}$	$\frac{1}{9}$
Gramineæ - - -	284	143	49	$\frac{1}{13}$	$\frac{1}{15}$	$\frac{1}{10}$
Junceæ - - -	42	20	20	$\frac{1}{88}$	$\frac{1}{94}$	$\frac{1}{25}$
These three Families together - -	460	265	124	$\frac{1}{8}$	$\frac{1}{7}$	$\frac{1}{4}$
Orchideæ - - -	54	44	11	$\frac{1}{87}$	$\frac{1}{43}$	$\frac{1}{45}$
Labiatae - - -	149	72	7	$\frac{1}{24}$	$\frac{1}{28}$	$\frac{1}{71}$
Rhinantheæ et Scrophuleæ - -	147	76	17	$\frac{1}{24}$	$\frac{1}{24}$	$\frac{1}{39}$
Boraginæ - - -	49	26	6	$\frac{1}{74}$	$\frac{1}{72}$	$\frac{1}{83}$
Ericæ et Rhododendreæ - -	29	21	20	$\frac{1}{125}$	$\frac{1}{90}$	$\frac{1}{35}$
Compositæ - - -	490	238	38	$\frac{1}{7}$	$\frac{1}{8}$	$\frac{1}{13}$
Umbelliferae - - -	170	86	9	$\frac{1}{34}$	$\frac{1}{23}$	$\frac{1}{35}$
Cruciferae - - -	190	106	22	$\frac{1}{19}$	$\frac{1}{18}$	$\frac{1}{23}$
Malvaceæ - - -	25	8	—	$\frac{1}{143}$	$\frac{1}{233}$	—
Caryophylleæ - - -	165	71	29	$\frac{1}{23}$	$\frac{1}{27}$	$\frac{1}{17}$
Leguminosæ - - -	230	96	14	$\frac{1}{18}$	$\frac{1}{18}$	$\frac{1}{35}$
Euphorbeæ - - -	51	18	1	$\frac{1}{11}$	$\frac{1}{104}$	$\frac{1}{487}$
Amentaceæ - - -	69	48	23	$\frac{1}{52}$	$\frac{1}{39}$	$\frac{1}{11}$
Coniferae - - -	19	7	3	$\frac{1}{192}$	$\frac{1}{269}$	$\frac{1}{185}$
	3645	1884	497			

1746. *The most universal plants are the agamous families.* Their germs are the only ones which nature develops spontaneously in all climates. The polytrichum commune (*fig. 244.*) grows in all latitudes; in Europe and under the equator; on high mountains and on a level with the sea; in short, wherever there is shade and humidity. No phanerogamous plants have organs sufficiently flexible to accommodate themselves in this manner to every zone. The alsine media, fragaria vesca, and solanum nigrum, have been supposed to enjoy this advantage; but all that can be said is, that these plants are very much spread, like the people of the race of Caucasus, in the northern part of the ancient continent. (*Humboldt.*)



244

#### SECT. VI. Economical Distribution of Vegetables.

1747. *The plants chiefly employed in human economy differ in different climates and countries;* but some, as the cereal grasses, are in universal use; and others, as the banana and plantain, only in the countries which produce them.

1748. *The bread-corn* of the temperate climates is chiefly wheat and maize; of the hot climates rice, and of the coldest climates barley.

1749. *The edible roots* of the old world are chiefly the yam, sweet potatoe, onion, carrot, and turnip; of the new the potatoe.

1750. *The oleraceous herbs* of temperate climates are chiefly the brassica family, and other cruciferæ. In hot climates pot-herbs are little used. Legumes, as the pea, bean, and kidney-bean, are in general use in most parts of the old world.

1751. *The fruits of the northern hemisphere* belong chiefly to the orders of Pomaceæ, Amygdalineæ, Grossulareæ, Rosaceæ, Viticææ, and Amentaceæ.

1752. *The fruits of the East Indies* belong chiefly to Myrtaceæ, Guttifereæ, Auranteæ, Musaceæ, Palmæ, Cucurbitaceæ, Myristicææ, &c.

1753. *The fruits of China* are chiefly of the orders of Auranteæ, Myrtaceæ, Rhamneæ, Pomaceæ, Amygdalineæ, Palmæ, &c.

1754. *The fruits of Africa* belong to Sapoteæ, Palmæ, Chrysobalanææ, Guttifereæ, Apocineæ, Papilionaceæ, Musaceæ, and Cucurbitaceæ.

1755. *The fruits of South America* belong to Annonaceæ, Myrtaceæ, Terebintaceæ, Myristicææ, Palmæ, Bromeliaceæ, Sapoteæ, Laurinææ, Chrysobalanææ, Musaceæ, Papilionaceæ, and Passifloreæ.

1756. *The most showy herbaceous flowers* of the temperate zone belong to Rosaceæ, Liliaceæ, Irideæ, Ericinææ, Ranunculaceæ, Primulaceæ, Caryophylleæ, Gentianeæ, &c. Those of the torrid zone belong to the Scitamineæ, Amaryllideæ, Bignoniaceæ, Melastomaceæ, Magnoliaceæ, Papilionaceæ, Apocineæ, &c.

1757. The most useful *timber-trees* of temperate climates are of the pine or fir kind; of warm climates the palm and bamboo. *The universal agricultural order is the Gramineæ.*

#### SECT. VII. *Arithmetical Distribution of Vegetables.*

1758. *The total number of species* of plants known, amounted in 1820 to about 44,000, of which 38,000 have been described. According to Humboldt and R. Brown, they are thus distributed: in Europe 7000; in temperate Asia 1500; in equinoctial Asia and the adjacent islands 4500; in Africa 3000; in temperate America, in both hemispheres, 4000; in equinoctial America 13,000; in New Holland and the islands of the Pacific Ocean 5000; — in all 38,000. In Spitzbergen there are 30 species of perfect plants; in Lapland 534; in Iceland 533; in Sweden 1299; in Scotland 900; in Britain 1400; in Brandenburg 2000; in Piedmont 2800; in Jamaica, Madagascar, and the coast of Coromandel, from 4000 to 5000. It is now (anno 1824) believed that there may be from 100,000 to 200,000 species of plants. Such is the progress of ideas.

#### SECT. VIII. *Distribution of the British Flora, indigenous and exotic.*

1759. *About thirteen thousand plants* compose the Hortus Britannicus, or such species as admit of cultivation. Mosses, Fungi, Fuci, Algæ, and Lichens are, with a few exceptions, excluded.

1760. *The natives of Britain* which enter into this Hortus are upwards of 1400 species; but the native British Flora contains in all above 3300 species. Of these there are about 1437 cotyledonous plants, and nearly 1893 of imperfect, or of what are termed, in the Jussicean system, acotyledoneæ.

1761. *Of the cotyledonous or perfect plants*, 182 are trees or shrubs; 855 are perennials; 60 are biennials; and 340 annuals. Of the trees and shrubs, 47 are trees; 25 above thirty feet high, and the remainder under thirty, but above 10 feet high. Of the perennials 83 are grasses; the next greatest number belong to the two first orders of the class Pentandria; the next to the Syngenesia; and the third to Monœcia Triandria, or the Cyperaceæ of Jussieu, comprehending chiefly the genus *Carex*. Most of the biennials belong to the first order of the 19th class, and the two first orders of Pentandria. There are 41 annual grasses; 52 annuals belong to the two first orders of Pentandria; and the next greatest number of annuals to Diadelphia Decandria, which includes the trefoils and vetches.

1762. *Of the Cryptogameæ, or imperfect plants*, 800 are fungi; 18 algæ, 373 lichens; 85 hepaticæ; 460 musci; and 130 ferns; according to an estimate (in *Rees's Cyclop. art. Plant.*) understood to be made by Sir J. E. Smith.

1763. In regard to the *distribution of the perfect plants* as to elevation, little or nothing has been yet generalised on the subject. In regard to soils, 276 are found in bogs, and marshy or moist places; 140 on the sea-shores; 128 in cultivated grounds; 121 in meadows and pastures; 78 in sandy grounds; 76 in hedges and on hedge-banks; 70 on chalky and other calcareous soils; 64 on heaths; 60 in woods; 30 on walls; 29 on rocks; and 19 on salt-marshes; — reckoning from Galpine's *Compend. Fl. Brit.*

1764. In the *distribution of the Cryptogameæ*, the ferns prevail in rocky places and wastes; most of the musci, hepatici, and lichens, on rocks and trees; most of the fuci and algæ in the sea; and of the fungi, on decaying vegetable bodies, especially trunks of trees, manures, &c.

1765. In respect to *geographical distribution*, the mountainous and hilly districts of England and South Wales are most prolific; the greatest number, according to extent of surface, are found in England and Wales, and the smallest number in Ireland.

1766. *The genera of the native British Flora* enter into 23 classes and 71 orders of the former, and 8 classes and 121 orders of the latter system.

1767. With respect to *the uses or application of the native Flora*, there are about 18 sorts of wild fruits which *may be eaten*, exclusive of the wild apple and pear; but only the pear, apple, plum, currant, raspberry, strawberry, and cranberry, are gathered wild, or cultivated in gardens. There are about 20 boiling culinary plants natives, including the cabbage, sea-kale, asparagus, turnip, carrot, and parsnep. There are about the same number of spinaceous plants, salading, and pot and sweet herbs, which may be used, but of which but a few only enter into the dietetics of modern cooks. There are three fungi, in general use, the mushroom, truffle, and morel; and various others, as well as about eight species of sea-weeds, are occasionally eaten. There are about six native plants cultivated as florists' flowers, including the primula elatior, crocus, narcissus, dianthus, &c. Nearly 100 grasses, clovers, and leguminous plants are used in agriculture, or serve in their native places of growth as pasturage for cattle. Two native plants, the oat and the big, or wild barley, are cultivated as farinaceous grains. Most of the trees are used in the mechanical arts, for fuel, or for tanning: one plant, the flax, not an aboriginal native, but now naturalised, affords fibre for the manufacture of linen cloth. Various plants yield colored juices, which may be, and in part are, used in dyeing; and some hundred species have been, and a few are still used in medicine. About 20 cotyledonous plants, and above 50 cryptogameæ, chiefly fungi, are, or are reputed to be, poisonous, both to men and cattle.

1768. By *the artificial Flora of Britain*, we understand such of the native plants as admit of preservation or culture in gardens; and such exotics as are grown there, whether in the open ground, or in different descriptions of plant habitations. The total number of species which compose this Flora, or *Hortus Britannicus*, as taken from Sweet's catalogue, is about 13,000, including botanists' varieties, and excluding agamous plants. This is nearly a fourth part of the estimated Flora of our globe, and may be considered in regard to the countries from whence the plants were introduced; the periods of their introduction; their obvious divisions; their systematic classification; their garden habitations; their application; and their native habitations.

1769. With respect to *the native countries of the artificial Flora or Hortus Britannicus*, of 970 species the native countries are unknown; the remaining 12,000 species were first introduced from the following countries:—

EUROPE.		ASIA.		AFRICA.		AMERICA.			
<i>Continent.</i>		<i>Continent.</i>		<i>Continent.</i>		<i>S. Continent.</i>		<i>N. Continent.</i>	
S. of Europe	659	East Indies	826	Cape of Good Hope	2280	Mexico	102	United States	1222
Spain	266	Siberia	364	Barbary	77	Peru	77	Carolina	129
Italy	202	Levant	213	Egypt	69	Brazil	74	Virginia	49
Hungary	173	China	205	Morocco	13	Guinea	33	Canada	28
Austria	171	Caucasus	67	Sierra Leone	12	Vera Cruz	22	Missouri	24
Germany	134	Persia	37	Guinea	11	Caraccas	21	Louisiana	18
Switzerland	117	Japan	36	Abyssinia	8	Chili	29	Georgia	16
France	103	Syria	19	Algiers	8	Buenos Ayres	8	Florida	9
Various other Parts	446	Various other Parts	82	Various other Parts	51	Various other Places	275	Other parts of British America and the United States	111
<i>Islands.</i>		<i>Islands.</i>		<i>Islands.</i>		<i>S. Islands.</i>		<i>N. Islands.</i>	
Madeira	75	New So. Wales	239	Canaries	82	Cayenne	9	West Indies	435
Candia	66	New Holland	152	Teneriffe	21	Falkland Islands	3	Jamaica	248
Other Islands	352	Ceylon	31	St. Helena	6	Terra del Fuego	1	Bahamas	9
Britain	1400	Van Dieman's Land	21	Cape Verde Islands	1			Other Islands	55
European plants in the artificial Flora of Britain								4169	
Asiatic								2365	
African								2639	
South America								644	
North America								2353	
Native countries unknown								970	
								13,140	

1770. With respect to *the dates of the introduction of the exotics* from those different countries, the dates of the introduction of none are known before the time of Gerard, in Henry VIII.'s reign. From this author and Trew, it appears that 47 species were introduced on or before 1548, including the apricot, fig, pomegranate, &c. Those previously introduced, of which the dates are unknown, may be considered as left here by the Romans, or afterwards brought over from France, Italy, and Spain, by the ecclesiastics.

and preserved in the gardens of the religious houses. Henry died in 1547; but the plants introduced in the year after his death, may be considered as properly belonging to his reign.

*Edw. VI.* 1547 to 1553. During this troublous reign, only seven exotic species were added to the British garden, chiefly by Dr. Turner, director of the Duke of Somerset's (then Lord Protector) garden at Zion House.

*Mary.* 1553 to 1558. No plants introduced.  
*Elizabeth.* 1558 to 1605. 533 species were introduced during this reign. Of these, 288 are enumerated in the first edition of Gerard's *Herbal*, published 1557. Drake's voyage round the world, Raleigh's discoveries in North America, and the consequent introduction of the tobacco and potatoe, took place during this reign.

*James I.* 1605 to 1625. Only 20 plants introduced during this period.

*Charles I.* 1625 to 1649. 331 plants introduced, which are chiefly mentioned by Parkinson, the first edition of whose work was published in 1629. Parkinson was the king's herbalist, and Tradescant his kitchen-gardener. A taste for plants began to appear among the higher classes during this reign; various private gentlemen had botanic gardens; and several London merchants procured seeds and plants for Lobel, Johnston, and Parkinson, through their foreign correspondents.

*O. and R. Cromwell.* 1649 to 1658. 95 plants introduced by the same means as before. Cromwell encouraged agriculture; but the part he acted left no leisure for any description of elegant or refined enjoyment.

*Charles II.* 1660 to 1685. 152 plants introduced, chiefly mentioned by Ray, Morrison, and different writers in the Transactions of the Royal Society, founded in 1663. The Oxford and Chelsea gardens were founded, or enlarged, during this reign. Sir Hans Sloane and Evelyn flourished. Many native plants were now brought into notice by Ray and Willoughby.

*James II.* 1685 to 1688. 44 plants introduced.

*William & Mary.* 1688 to 1702. 298 species introduced, chiefly from the West Indies, and through Sir Hans Sloane and the Chelsea garden. Plunket succeeded Parkinson as royal herbalist during this reign; and botanists were sent from England, for the first time, to explore foreign countries. As in the two former reigns great additions were now made to the indigenous Flora, by Ray, Sibbald, Johnson, and others. Many of the 65 species annually presented to the Royal Society were natives.

*Anne.* 1702 to 1714. 250 plants in great part from the East and West Indies, and through the Chelsea garden.

1771. With respect to the *obvious character of the artificial Flora*, 350 species are hardy trees or shrubs; of these 270 are trees above 10, and 100 trees above 30 feet high. Of these, the larch, spruce fir, silver fir, and Lombardy poplar, sometimes attain the height of 100 feet. Above 400 species are hardy grasses. Of the tender exotics, the greater number are trees or shrubs, and the next greatest number annuals and bulbs. The colors of the blossoms are generally rich and vivid in proportion to the warmth of the climate of which the plants are natives.

1772. *Purchasable British Flora.* The whole of the plants enumerated as forming the British Flora, are probably not at any one time all in existence in Britain. Many of them, especially the exotic species, which were introduced at Kew, have been lost there through accidents or diseases, and are wanting for a time till new seeds or plants are obtained from abroad. Had they been distributed among the nurserymen they would have been abundantly multiplied and spread over the country. Casualties happen even to hardy plants, and a species which at one time is to be found in moderate quantities in the nurseries is at another period comparatively scarce. Thus, if we reduce the actual number of species to be found in cultivation at one time to from 9000 to 10,000, it will be found nearer the truth. In the public nurseries, varieties are very much cultivated, in order, as it were, to place the beauties of esteemed species in different points of view; or to produce in vegetables something analogous to what are called variations in musical compositions. The following may be considered as a popular or horticultural distribution of the species and varieties obtainable from British nurseries. It is taken from a catalogue entitled *Prodromus, &c.*; or Forerunner of the collection in Page's Southampton nursery-garden, drawn up by L. Kennedy, (late of the Hammersmith nursery,) and published in 1818. It is a work of great practical utility, and with Sweet's *Hortus*, should be in the hands of every gardener, who has a collection of plants under his care.

1773. *Hardy Plants.*

Trees above 30 feet high	Sp. & Var.	100	Hardy climbing shrubs	Sp. & Var.	150	Marsh plants	Sp. & Var.	300
Trees under 30 and above 10 feet high	200	Herbaceous plants	2500	Biennials	300			
Deciduous shrubs	500	Grasses introduced in botanic collections	150					
Roses, double and single	350	Bulbous-rooted plants	250					
Evergreen shrubs	400	Aquatics	50					Total 4580

1774. *Green-house and Dry-stove Plants.*

Trees and shrubs	Sp. & Var.	1450	Climbers	Sp. & Var.	90	Herbaceous and stemless plants	Sp. & Var.	240
Heaths	400	Succulents	170					
Geraniums	150	Mezembryanthemums	160					Total 3180
Proteas	120	Bulbous-rooted plants	500					

*George I.* 1714 to 1727. 182 plants, chiefly through the Chelsea garden.

*George II.* 1727 to 1760. 1770 plants, almost entirely through the Chelsea garden, now in its zenith of fame under Miller. 375 of these plants are stated as introduced in 1730 and 1731, the latter being the year in which the first folio edition of the *Gardener's and Botanist's Dictionary* appeared. 239 in 1739, in which year the 4th edition of the same work appeared. 196 in 1752, and above 400 in 1758 and 1759, when subsequent editions were published. In the last, in 1763, the number of plants cultivated in England is stated to be more than double the number contained in the edition of 1731.

*George III.* 1760 to 1817. 6756 plants introduced, or considerably above half the whole number of exotics now in the gardens of this country. This is to be accounted for from the general progress of civilisation, and the great extension of British power and influence in every quarter of the world; especially in the East Indies, at the Cape of Good Hope, and New South Wales. The increasing liberality of intercourse which now obtained among the learned of all countries, must also be taken into account, by which, notwithstanding the existence of political differences, peace reigned and commerce flourished in the world of science. *George III.* may also be said to have encouraged botany, aided by the advice, assistance, and unwearied efforts of that distinguished patron of science, Sir Joseph Banks, and the garden of Kew, and its late curator, Aiton, became the Chelsea garden, and the Miller of this reign. Most of the new plants were sent there, and first described in the *Hortus Kewensis*. The next greatest numbers were procured by the activity of the London nurserymen, especially Lee, and Loddiges, and described in the *Botanical Magazine*; Andrew's *Heathery*; the *Botanical Register*; Loddiges' *Cabinet*, and other works. The greatest number of plants introduced in any one year, during this period, is 536 in 1800, chiefly heaths and proteas from the Cape of Good Hope, taken from the Dutch in 1795. The following are the numbers annually introduced since that period:—

1801.	- 116	1805.	- 169	1809.	- 48	1813.	- 42
1802.	- 169	1806.	- 224	1810.	- 68	1814.	- 44
1803.	- 267	1807.	- 61	1811.	- 149	1815.	- 192
1804.	- 299	1808.	- 52	1812.	- 316	1816.	- 301

Annual Average of 17 years, ending 1816, 156 species.

1775. *Hot-house Plants.*

	Sp. & Var.		Sp. & Var.
Trees and shrubs	850	Aquatics	25
Climbers	150	Reedy or scitaminous	55
Succulent plants	130		
Bulbous-rooted plants	80		
Herbaceous	170		
		Total	1463

1776. *Annuals, native and exotic.*

	Sp. & Var.		Sp. & Var.
Hardy	300	Used in agriculture exclusive of grasses	80
Half hardy	140		
Tender	100		
Esculent	200		
		Total	820

Total. Hardy, 4580; green-house and dry-stove, 3180; hot-house, 1463; annuals, 820; total, 10,043; of these, above 3000 may be considered as varieties, so that the actual hortus procurable in British nurseries, may be estimated, as to the British hortus of books, as 7 to 12, or including the cryptogamous plants, as 8 to 12.

1777. With respect to the application of the purchasable *Flora of Britain*, including species and varieties, we submit the following as only a rude outline, the subject not admitting of perfect accuracy from the ever-varying number of varieties.

1778. *Varieties of Fruit-trees, and Fruit-bearing Plants, for Sale in British Nurseries.*

	Sp. & Var.		Sp. & Var.		Sp. & Var.
Apples	300	Apricots	30	Cranberry	1
Pears	300	Plums	150	Mulberries	2
Medlars	2	Cherries	100	Filberts	6
Quinces	2	Grapes	50	Walnuts	3
Services	5	Figs	50	Chestnuts	5
Oranges and Lemons	60	Gooseberries	200	Melons	15
Peaches	100	Currants	4	Pine-apples	20
Nectarines	50	Raspberries	10		
Almonds	6	Strawberries	20		
				Total	1417

1779. *Esculent Herbaceous Plants, annuals and perennials, used in Horticulture.*

	Sp. & Var.		Sp. & Var.		Sp. & Var.
Cabbage tribe	1	Pot herbs and garnishings	16	Edible wild plants which may be used	31
Leguminous plants	35	Sweet herbs	20	Edible fungi	5
Esculent roots	10	Plants used in confectionary and domestic medicine	18	Edible fuci	8
Spinaceous plants	6	Plants used as preserves and pickles	26		
Alliaceae plants	7			Total	154
Asparaginous plants	11				
Acetaceae plants	25				

1780. *Florists' Flowers, used in Floriculture.*

	Sp. & Var.		Sp. & Var.		Sp. & Var.
<i>Bulbous-rooted Plants.</i>		Colchicums	10	<i>Tuberous rooted Plants.</i>	
Hyacinths	200	Other sorts	100	Dahlias	400
Tulips	300			Paeonies	20
Crocuses	100	<i>Fibrous rooted Plants.</i>		Ranunculuses	500
Narcissi	200	Auriculars	200	Anemonies	200
Iris	60	Polyanthi	100		
Fritillaries	20	Primroses	20		
Crown-imperials	20	Cowslips	10		
Dens canis	6	Pinks	200		
		Carnations	500		
				Total	2666

1781. *Hardy Timber-trees and Shrubs, used in Arboriculture, Floriculture, and Landscape-gardening.*

	Sp. & Var.		Sp. & Var.
Trees planted for timber	100	Shrubs planted for various uses, as fuel, charcoal, bark, firewood, &c.	20
other useful purposes	20		
Trees planted for ornament	180		
Hedge-plants	10		
		Total	330

1782. *Agricultural Herbaceous Plants, grown for Food for Men and Cattle, and for use in various Arts.*

	Sp. & Var.		Sp. & Var.
Grains for human food	4	Plants used for dyeing	2
Leguminous seeds	10	Plants used for the clothing arts	2
Roots	6	Sea plants used	6
Herbage plants, not grasses	9	Mosses used in dyeing	1
grasses, and grasses for grains for the inferior animals	20	for various purposes in the arts	6
Plants used for furnishing oils and essences	5		
		Total	65

1783. *Miscellaneous applications of Hardy Perennials, native and exotic.*

	Sp. & Var.		Sp. & Var.
Border-flowers, or such as are used in flower-gar-	300	Used for distillation and perfumery	20
dens and shrubberies, in ordinary cases about	50		
Used in the modern pharmacopias	50		
Sold by herbalists, and used by quacks and irregular practitioners	20		
		Total	870

1784. *Application of curious hot-house exotics, or such plants of ornament as require the protection of glass.* Of these there are in ordinary green-houses seldom more than 100 species and varieties, and not more than half that number in most of our plant-stoves. The remainder of this class are confined to the public and private botanic gardens, and to eminent public nurseries. Many of this division are of great importance in their native countries, as the indigo, sugar-cane, tea-tree, cinnamon, &c.; the mango, durion, and other excellent fruits, the palms, bamboos, &c. Even some, here treated as entirely ornamental, afford useful products in their own countries, as the camellia, sun-flower, &c. from the seeds of which oils are expressed in China and America. The cultivation



or preservation of living specimens of these plants, therefore, in our green-houses and stoves, is a rational entertainment, and also useful, as many species become in time acclimated, and some even naturalised; and uses may in time also be discovered for such as are now merely looked on as objects of curiosity. But it is quite enough to justify much more than all the care that is taken to obtain and preserve them, that they contribute to elegant enjoyment; for what is life when it does not exceed mere obedience to the animal instincts?

1785. With respect to the *native habitations of the exotic part of the British Hortus*, little can be advanced with certainty. In general it seems to appear that moist and moderately warm climates, and irregular surfaces, are most prolific in species; and judging of the whole world from Europe, we should venture to consider half the species of plants in existence as growing in soft and rather moist grounds, whether low or elevated. The soil of surfaces constantly moist, or inclining to be moist, whether watered from the atmosphere or from subterraneous sources, is almost always found to be minutely divided, and generally of a black vegetable or peaty nature. Immense tracts in Russia and America are of this description, and even when dry, resist evaporation better than any other. In such soils, the roots of plants are generally small and finely divided, as in the heaths, most bog plants, and nearly all the American shrubs. The next sort of habitation most prolific in species, appears to us to be arenarious soils in temperate climates, and in proportion to their moisture. Here the roots of plants are also small, but less so than in soil of the former description. On rocky and calcareous soils the roots of plants are generally strong and woody, or at least long and penetrating. In clayey habitations, exclusive of the alluvial depositions of rivers, few plants are found, and these generally grasses, or strong fibrous-rooted herbaceous plants, or tap-rooted trees. Such at least is the amount of our generalisations; but as our observation has been limited to Europe, and does not even extend to the whole of it, those who have visited Africa and Asia are much more capable of illustrating the subject. One conclusion we think the cultivator is fully entitled to draw, that the greater number of plants, native or foreign, will thrive best in light soil, such as a mixture of soft black vegetable mould or peat and fine sand kept moderately moist; and that on receiving unknown plants or seeds, of the native sites of which he is ignorant, he will err on the safe side by placing them in such soils rather than in any other; avoiding, most of all, clayey and highly manured soils, as only fit for certain kinds of plants constitutionally robust, or suited to become monstrous by culture.

---

## CHAP. VII.

### *Origin and Principles of Culture as derived from the Study of Vegetables.*

1786. The final object of all the sciences is their *application to purposes subservient to the wants and desires of men*. The study of the vegetable kingdom is one of the most important in this point of view, as directly subservient to the arts which supply food, clothing, and medicine; and indirectly to those which supply houses, machines for conveying us by land, or by water, and in short almost every comfort and luxury. Without the aid of the vegetable kingdom, few mineral bodies would be employed in the arts, and the great majority of animals, whether used by man as laborers, or as food, could not live.

1787. *Agriculture and gardening* are the two arts which embrace the whole business of cultivating vegetables, for whatever purpose they are applied by civilized man. Their fundamental principles as arts of culture are the same; they are for the most part suggested by nature, and explained by vegetable chemistry and physiology (Chap. III. and IV.); and most of them have been put in practice by man for an unknown length of time, without much reference to principles. All that is necessary, therefore, for effecting this branch of culture, is to imitate the habitation, and to propagate. This is, or ought to be the case, wherever plants are grown for medical or botanical purposes, as in herb and botanic gardens. Nature is here imitated as exactly as possible, and the result is, productions resembling, as near as possible, those of nature.

1788. *To increase the number and improve the qualities of plants*, it is necessary to facilitate their mode of nutrition by removing all obstacles to the progress of the plant. These obstacles may either exist under or above the surface; and hence the origin of draining, clearing from surface-incumbrances, and the various operations, as digging, ploughing, &c. for pulverising the soil. Nature suggests this in accidental ruptures of the surface, broken banks, the alluvial depositions from overflowing rivers, and the earth thrown up by underground animals. Many of the vegetables within the

influence of such accidents are destroyed, but such as remain are ameliorated in quality, and the reason is, their food is increased, because their roots, being enabled to take a more extensive range, more is brought within their reach.

1789. *It is necessary, or at least advantageous, to supply food artificially; and hence the origin of manuring.* All organised matters are capable of being converted into the food of plants; but the best manure for ameliorating the quality, and yet retaining the peculiar chemical properties of plants, must necessarily be decayed plants of their own species. It is true that plants do not differ greatly in their primary principles, and that a supply of any description of putrescent manure will cause all plants to thrive; but some plants, as wheat, contain peculiar substances, (as gluten and phosphate of lime,) and some manures, as those of animals, or decayed wheat, containing the same substances, must necessarily be a better food or manure for such plants. Manuring is an obvious imitation of nature, every where observable by the decaying herbage of herbaceous plants, or the fallen leaves of trees, rotting into dust or vegetable mould about their roots; and by the effect of the dung left by pasturing or other animals.

1790. *Amelioration of climate is farther advantageous, in improving the qualities of vegetables, by increasing or diminishing its temperature according to the nature of the plant; unless, indeed, it is situated in a climate which experience and observation show to be exactly suited to its nature.* Hence the origin of shelter and shade, by means of walls, hedges, or strips of plantation; of sloping surfaces or banks, to receive more directly or indirectly the rays of the sun; of rows, drills, and ridges, placed north and south in preference to east and west, in order that the sun may shine on both sides of the row, drill, or ridge, or on the soil between rows and drills every day in the year; of soils better calculated to absorb and retain heat; walls fully exposed to the south, or to the north; of training or spreading out the branches of trees on these walls; of hot-walls; of hot-beds; and finally of all the variety of hot-houses. Nature suggests this part of culture, by presenting, in every country, different degrees of shelter, shade, and surface, and in every zone different climates.

1791. *The regulation of moisture is the next point demanding attention; for when the soil is pulverised, it is more easily dried by the penetration of the air; when an increase of food is supplied, the medium through which that food is taken up by the plant should be increased; and when the temperature is increased, evaporation becomes greater.* Hence the origin of watering by surface or subterraneous irrigation, manual supplies to the root, showering over the leaves, steaming the surrounding atmosphere, &c. This is only to imitate the dews and showers, streams and floods of nature; and it is to be regretted that the imitation is in most countries attended with so much labor, and requires so much nicety in the arrangement of the means, and judgment in the application of the water, that it is but very partially applied by man in every part of the world, excepting perhaps a small district of Italy. But moisture may be excessive; and on certain soils at certain seasons, and on certain productions at particular periods of their progress; it may be necessary to carry off a great part of the natural moisture, rather than let it sink into the earth, or draw it off where it has sunk in and injuriously accumulated, or prevent its falling on the crop at all; and hence the origin of surface-drainage by ridges, and of under-draining by covered conduits, or gutters; and of awnings and other covers to keep off the rain or dews from ripe fruits, seeds, or rare flowers.

1792. *The regulation of light is the remaining point.* Light sometimes requires to be excluded and sometimes to be increased, in order to improve the qualities of vegetables; and hence the origin of thinning the leaves which overshadow fruits and flowers, the practice of shading cuttings, seeds, &c., and the practice of blanching. The latter practice is derived from accidents observable among vegetables in a wild state, and its influence on their quality is physiologically accounted for by the obstruction of perspiration, and the prevention of the chemical changes effected by light on the epidermis.

1793. *Increasing the magnitude of vegetables, without reference to their quality, is to be obtained by an increased supply of all the ingredients of food, distributed in such a body of well pulverised soil as the roots can reach to; of heat and moisture; of a partial exclusion of the direct rays of the sun, so as to moderate perspiration; and of wind, so as to prevent sudden desiccation.* But experience alone can determine what plants are best suited for this, and to what extent the practice can be carried. Nature gives the hint in the occasional luxuriance of plants accidentally placed in favorable circumstances, and man adopts it, and improving on it, produces cabbages and turnips of half a cwt.; apples of one pound and a half; and cabbage-roses of four inches in diameter; productions which may in some respects be considered as diseased.

1794. *To increase the number, improve the quality, and increase the magnitude of particular parts of vegetables.* It is necessary, in this case, to remove such parts of the vegetable as are not wanted, as the blooms of bulbous or tuberous rooted plants, when

the bulbs are to be increased, and the contrary; the water-shoots and leaf-buds of fruit-trees; the flower-stems of tobacco; the male flowers and barren runners of the cucumis tribe, &c. Hence the important operations of pruning, ringing, cutting off large roots, and other practices for improving fruits and throwing trees into a bearing state. At first sight these practices do not appear to be copied from nature; but, independently of accidents by fire, already mentioned, which both prune and manure, and of fruit-bearing trees, say thorns or oaks, partially blown out by the roots, or washed out of the soil by torrents, which always bear better afterwards, why may not the necessity that man was under, in a primitive state of society, of cutting or breaking off branches of trees, to form huts, fences, or fires, and the consequent vigorous shoots produced from the parts where the amputation took place, or the larger fruit on that part of the tree which remained, have given the first idea of pruning, cutting off roots, &c. It may be said that this is not nature but art; but man, though an improving animal, is still in a state of nature, and all his practices, in every stage of civilisation, are as natural to him as those of the other animals are to them. Cottages and palaces are as much natural objects as the nests of birds, or the burrows of quadrupeds; and all the laws and institutions by which social man is guided in his morals and politics, are no more artificial than the instinct which congregates sheep and cattle in flocks and herds, and guides them in their choice of pasturage and shelter.

1795. *To form new varieties of vegetables*, as well as of flowers and useful plants of every description, it is necessary to take advantage of their sexual differences, and to operate in a manner analogous to crossing the breed in animals. Hence the origin of new sorts of fruits, grains, legumes, and roots. Even this practice is but an imitation of what takes place in nature by the agency of bees and other insects, and the wind; all the difference is, that man operates with a particular end in view, and selects individuals possessing the particular properties which he wishes to perpetuate or improve. New varieties, or rather subvarieties, are formed by altering the habits of plants; by dwarfing through want of nourishment: variegating by arenacious soils; giving or rather continuing peculiar habits when formed by nature, as in propagating from monstrosities — fasciculi of shoots, weeping shoots, shoots with peculiar leaves, flowers, fruit, &c.

1796. *To propagate and preserve from degeneracy approved varieties of vegetables*, it is in general necessary to have recourse to the different modes of propagating by extension. Thus choice apples and tree fruits could not be perpetuated by sowing their seeds, which experience has shewn would produce progeny more or less different from the parent, but they are preserved and multiplied by grafting; others, as the pine-apple, by cuttings or suckers; choice carnations by layers, potatoes by cuttings of the tubers, &c. But approved varieties of annuals are in general multiplied and preserved by selecting seeds from the finest specimens and paying particular attention to supply suitable culture. Approved varieties of corns and legumes, no less than of other annual plants, such as garden flowers, can only be with certainty preserved by propagating by cuttings or layers, which is an absolute prolongation of the individual; but as this would be too tedious and laborious for the general purposes both of agriculture and gardening, all that can be done is to select seeds from the best specimens. This part of culture is the farthest removed from nature; yet there are notwithstanding examples of the fortuitous graft; of accidental layers; and of natural cuttings, as when leaves, or detached portions of plants (as of the *cardamine hirsuta*) drop and take root.

1797. *The preservation of vegetables for future use* is effected by destroying or rendering dormant the principle of life, and by warding off, as far as practicable, the progress of chemical decomposition. When vegetables or fruits are gathered for use or preservation, the air of the atmosphere which surrounds them is continually depriving them of carbon, and forming the carbonic acid gas. The water they contain, by its softening qualities, weakens the affinity of their elements; and heat produces the same effect by dilating their parts, and promoting the decomposing effect both of air and water. Hence, drying in the sun or in ovens, is one of the most obvious modes of preserving vegetables for use, as food, or for other purposes; but not for growth, if the drying processes is carried so far as to destroy the principle of life in seeds, roots, or sections of the shoots of ligneous plants. Potatoes, turnips, and other esculent roots, may be preserved from autumn till the following summer, by drying them in the sun, and burying them in perfectly dry soil, which shall be at the same time at a temperature but a few degrees above the freezing point. Corn may be preserved for many years by first drying it thoroughly in the sun, and then burying it in dry cool pits, and closing these so as effectually to exclude the atmospheric air. In a short time the air within is changed to carbonic acid gas, in which no animal will live, and in which, without an addition of oxygen or atmospheric air, no plant or seed will vegetate. The corn is thus preserved from decomposition, from insects, vermin, and from vegetation in a far more effectual manner than it can be in a granary. In this way the Romans preserved their corn

in chambers hewn out of dry rock, the Moors in the sides of hills, the Chinese, at the present time, in deep pits, in dry soil, and the aboriginal nations of Africa, as we have seen (1110.), in earthen vessels hermetically sealed. (*Lasteyrie des fosses propres à la Conservation des Grains. Chaptal Chimie appliquée à l'Agriculture*, tom. ii. ch. 10.) The origin of these practices are all obvious imitations of what accidentally takes place in nature, from the withered grassy tressock to the hedgehog's winter store; and hence the origin of herb, seed, fruit, and root rooms and cellars, and packing plants and seeds for sending to a distance.

1798. *The whole of the arts of vegetable culture*, is but a varied developement of the above fundamental practices, all founded in nature, and for the most part rationally and satisfactorily explained on chemical and physiological principles. Hence the great necessity of the study of botany to the cultivator, not in the limited sense in which the term is often taken as including mere nomenclature and classification, but in that extended signification in which we have here endeavored, proportionately to our limited space, to present the study of the vegetable kingdom. Those who would enter more minutely into the subject will have recourse to the excellent work of Keith, from whom we have quoted at such length; to Sir J. E. Smith's *Introduction*; and to the elementary works of Willdenow and De Candolle.

## BOOK II.

### OF THE STUDY OF THE ANIMAL KINGDOM WITH REFERENCE TO AGRICULTURE.

1799. *Animals are distinguished from vegetables by being endowed with sentiment or reason, and locomotive powers.* A general knowledge of their nature is of obvious utility to whoever is engaged in the rearing or management of any department of them; but, as they differ much more extensively in their natures than vegetables, that knowledge is necessarily very extensive. Few, indeed, can be supposed to attain to any degree of eminence in every branch; man is found sufficient for the physician, and the horse for the veterinary professor; a slight general knowledge of the whole subject, and a more particular acquaintance with the names and physiology of the quadrupeds, birds, and insects of Britain, are what the agriculturist should chiefly aspire to.

1800. The subject of *zoology* has not been cultivated with so much success as that of *botany*; the systematic part, indeed, was attended to by Linnæus, in common with the two other kingdoms of nature; but his arrangement of animals is much less satisfactory than his classification of plants; and scarcely any thing was done in comparative anatomy and physiology till within the last half century. The greatest improvers of this science are Hunter and Cuvier; but the most valuable works for the study of the agriculturist are Dr. Fleming's *Philosophy of Zoology*, and his *British Fauna*. It is from the first of these works that we have extracted the principal part of the following chapters, which we have arranged as Systematic Zoology, Animal Anatomy, Chemistry, Physiology, Pathology, Distribution, Uses, and Artificial Improvement, or Animal Culture.

### CHAP. I.

#### *Systematic Zoology, or the Language, Nomenclature, Description, and Classification of Animals.*

1801. *The technical terms introduced in zoology* are much more numerous than those of botany, because animals differ more among themselves than plants; and because the anatomy of animals is greatly more complicated than that of vegetables. The technical terms most important for the agriculturist are those made use of in the veterinary art, and which he ought to study in works on that subject, and in scientific treatises on the domestic quadrupeds. As the terms of zoology are much less fixed, and have not engaged the attention of naturalists so much as those of botany, the chief dependence of the student must be on a knowledge of the Latin language, in which they are generally composed.

1802. *In describing animals*, naturalists follow the same rules in zoology as in botany; but much more attention is requisite to the internal characters than in the latter science. In all cases the male is considered as the representative of the species. While the female, in some species, differs remarkably from the male in external characters, there is still an

agreement in structure, with the exception of the organs of the reproductive system, and the modifications of some parts subservient to their functions. When a female individual comes under notice, it is frequently very difficult, if not impossible, to determine the species to which she belongs, while external characters alone are employed. This difficulty, in the case of birds, meets the student at every step; but it in a great measure disappears, when the internal characters are chiefly relied on. In Great Britain, during the latter half of the last century, descriptions of animals were chiefly drawn up in a very superficial manner. The internal structure was in a great manner overlooked, and the more obvious varieties of color were selected, rather than the more characteristic appearances of the shape. Such, generally, are the descriptions of Pennant, Shaw, Donovan, and even Montagu. This is the more surprising, as the eminent naturalists who flourished towards the end of the seventeenth and beginning of the eighteenth centuries (the golden age of British zoology), excelled in the minute details with which their descriptions abounded. The writings of Willoughby, Ray, and Ellis, furnish very striking examples. But descriptions are daily becoming more labored in their details, from the increase of species, and the necessity of determining the characters on which their claim depends. This will contribute greatly to the progress of zoology.

1803. *The best descriptions are often insufficient, without the aid of drawings or specimens.* Many relations of parts, and many gradations of form, may be perceived by the eye, which words are unable to express. Drawings therefore have largely contributed to the progress of zoology. Specimens can only be obtained generally of the smaller animals, though examples of the largest sorts are to be found in the public museums. They are generally exhibited in a dried state; but sometimes immersed in spirits of wine. Marine objects are prepared by maceration in fresh water. Dried subjects are commonly anointed with some poisonous liquid, to preserve them from the attacks of insects. In a small tract entitled *Taxidermy*, will be found plain instructions for collecting and preserving zoological specimens.

1804. *In naming animals*, the same principles are followed as in naming plants; but it is remarkable, as Dr. Fleming has observed, that while in botany and mineralogy, generic titles are frequently the names of those naturalists who have contributed to the advancement of these sciences, yet the generic titles of animals are never derived from the same source, nor similar honors bestowed on zoological observers. Specific names are, as in botany, adjectives in concord with the generic name as a substantive; and should express some circumstance connected with color, form, habit, station, or distribution. In some cases the specific name is a substantive, and occurs either in the nominative or genitive case, and without reference to the gender of the name of the genus. This want of concord happens, when a species has been long known by a distinct appellation, and when this is employed in science as its specific name. Thus, in the genus *Turdus*, while one species is distinguished in the ordinary manner, viz. *T. torquatus*, another, *T. merula*, furnishes an example of the exception here referred to. When the specific name is in the genitive case, it is always derived from the proper name of the zoologist who discovered it, or who contributed to illustrate its characters. Thus *Liparis Montagui* was so named by Donovan (*British Fishes*, tab. lxxviii.) in honor of the late George Montagu, Esq. who first detected it on the Devonshire coast. The application of the proper names of zoologists, to the construction of the specific names of animals, ought to be restricted to those who have illustrated the species. Of late years, however, this honor has been bestowed on observers to whom the species has even been unknown; and not contented with using the names of zoologists, those of wives, friends, or patrons, have been extensively employed. To bestow zoological honors on those who are not interested in the progress of science is ridiculous; and to neglect the original discoverer, in order to do this, is base. It were better, perhaps, to proscribe the practice.

1805. *The classification of animals is by no means established on so firm and philosophical a basis as that of plants.* Two different methods have been employed; the one founded on a particular system of organs which constitutes the artificial system of Linnaeus, and the other founded on the joint consideration of all the systems of organs, external and internal, from which has been established various natural methods, of which the most generally esteemed at present is that of Cuvier. A mixed method has been adopted by many naturalists, and is preferred by Dr. Fleming, who suggests some useful improvements, and has exhibited their application in the general arrangement of animals to be given in his *Fauna*. (*Phil. Zool.* ii. 160.)

## CHAP. II.

*Animal Anatomy.*

1806. *The leading organs of animal structure, may be conveniently arranged as external and internal.*

SECT. I. *External Anatomy of Animals.*

1807. *All animals agree in possessing an exterior covering, or skin, to modify their surface, regulate their form, and protect them from the action of surrounding elements. In the more perfect animals, this organ consists of the following parts: the cuticle, — the corpus mucosum, — the corium, — the panniculus, — and the cellular web.*

1808. *The cuticle is destitute of blood vessels, nerves, and fibres, and usually consists of a thin transparent membrane possessing little tenacity. In those animals which live on the land, it is more rigid in its texture, and scaly and dry on its surface, than in those which reside in the water. In aquatic animals, it is in general smooth, often pliable; and, in many cases its texture is so soft and delicate, that it appears like mucus. It assumes, likewise, other appearances, such as scales, nails, shells and plates, which deserve the attentive consideration of the naturalist, as furnishing him with important characters for the arrangement of animals.*

1809. *The mucus web occurs immediately underneath the cuticle, from which, in general, it may be easily disjoined; but it is often so closely attached to the true skin below, as not to be separated even by maceration in water.*

1810. *The corium (Cutis vera), or true skin, lies immediately underneath the cuticle or mucus web. It is usually destitute of color. It consists in some animals, as quadrupeds, of solid fibres, which cross one another in every possible direction, and form a substance capable of considerable extensibility and elasticity. It is more obviously organized than the two members by which it is covered. Blood vessels and nerves penetrate its substance, and may be observed forming a very delicate net work on its surface.*

1811. *The muscular web varies greatly in its appearance according to the motions which the skin and its appendices are destined to perform. It consists of a layer of muscles, the extremities of whose fibres are inserted into the corium externally, and adhere to the body internally in various directions. This layer is very obvious in the hedgehog and the porcupine, to assist in rolling up the body and moving the spines, and in birds, in the erection of their feathers. In man it can scarcely be said to exist, unless in the upper parts, where cutaneous muscles may be observed, destined for moving the skin of the face, cheeks, and head. In the skin of the frog, the only cutaneous muscles which can be observed, are seated under the throat; the skin on the other parts of the body being loose and unconnected with the parts beneath. The use of this layer of the integument, is to corrugate the skin, and elevate the hairs, feathers or spines with which it is furnished.*

1812. *The cellular web forms the innermost layer of the common integuments, and rests immediately on the flesh of the body. It consists of plates crossing one another in different directions, and forming a cellular membrane, varying in its thickness, tenacity, and contents, according to the species. In frogs it does not exist. The cells of this membrane are filled with various substances, according to the nature of the animal. In general they contain fat, as in quadrupeds and birds. In some of these the layer is interrupted, as in the ruminating animals, while it is continuous in others, as the boar and the whale. In birds, while a part of this web is destined for the reception of fat, other portions are receptacles for air. In the moon-fish the contained matter resembles albumen in its chemical characters.*

1813. *The appendices of the skin are hairs, feathers, horns, scales, shells, and crusts.*

1814. *Hairs differ remarkably not only in their structure, but likewise in their situation. In some cases they appear to be merely filamentous prolongations of the cuticle, and subject to all its changes. This is obviously the case with the hair which covers the bodies of many caterpillars, and which separates along with the cuticle, when the animal is said to cast its skin. In true hair the root is in the form of a bulb, taking its rise in the cellular web. Each bulb consists of two parts, an external, which is vascular, and from which the hair probably derives its nourishment; and an internal, which is membranous, and forms a tube or sheath to the hair during its passage through the other layers of the skin. From this bulb, and enveloped by this membrane, the hair passes through the corium, mucus web, and cuticle. It usually raises up small scales of this last layer, which soon become dry and fall off, but do not form the external covering of the hair as some have supposed. The hair itself consists of an external horny covering, and a central vascular part, termed *medulla* or *pith*. This horny covering consists of numerous filaments placed laterally, to which different kinds of hair owe their striated appearance. These filaments appear of unequal lengths, those nearest the centre being longest; and, consequently, the hair assumes the form of an elongated cone, with its base seated in the skin. This form gives to the hair that peculiar property on which the operation of *felting* depends. In consequence of this structure of the surface, if a hair is seized at the middle between two fingers, and rubbed by them, the root will gradually recede, while the point of the hair will approach the fingers; in other words, the hair will exhibit a progressive motion in the direction of the root, the imbricated surface preventing all motion in the opposite direction. It is owing to this state of the surface of hairs, that woollen cloth, however soft and pliable, excites a disagreeable sensation of the skin in those not accustomed to wear it. It likewise irritates sores by these asperities, and excites inflammation. The surface of linen cloth, on the other hand, feels smooth, because the fibres of which it consists possess none of those inequalities of surface by which hairs are characterised.*

1815. *If a quantity of wool be spread upon a table, covered with a woollen cloth, and pressed down in different directions, it is obvious that each hair will begin to move in the direction of its root, as if it had been rubbed between the fingers. The different hairs thus moving in every direction become interwoven with each other, and unite in a continuous mass. This is the felt with which hats are made. Curled hairs entwine themselves with one another more closely than those which are straight, though flexible, as they do not, like these, recede from the point of pressure in a straight line; and hence hatters employ various methods to produce curl in the short fur of rabbits, hares, and moles, which they employ. This is accomplished chiefly by applying the solution of certain metallic salts to the fur by a brush; so that, when the hairs are dry, the surface which was moistened, contracts more than the other, and produces the requisite curve.*

1816. *It is owing to the asperities of the surface of hair that the spinning of wool is so difficult. This is in a great measure removed, by besmearing it with oil, by which the inequalities are filled up, or, at least,*

the asperities become less sensible. When the wool is made into cloth, it is necessary to remove the oil, which is done by the process of fulling. The cloth is placed in a trough, with water and clay, and agitated for some time. The oil is removed by the clay and water, while the agitation, acting like pressure, brings the hairs into closer union, and the cloth is taken out, not only cleansed, but felted. The hairs of every thread entwine themselves with those which are contiguous; so that the cloth may be cut without being subject to ravel. It is to this tendency to felt that woollen cloth and stockings increase in density, and contract in dimensions, by being washed. In many places woollen stuffs are felted, on a small scale, by placing them in running water, or under cascades; and the Zetlanders expose them to the motions of the tides, in narrow inlets of the sea.

1817. *In general there is a close connection between the color of the hair and that of the mucus web.* This is displayed in those animals which are spotted, in which the color of the skin is generally variegated like that of the hair.

1818. *Hairs differ remarkably in form.* In general they are round. Frequently on the body they are thickest in the middle. Sometimes they are flat, or two-edged; and, in the whiskers of seals, they are waved on the margins. In many animals they are long and straight; while, in others, they are crisped, and are then termed *wool*. When stiff, they are termed *bristles*; and, when inflexible, *spines*.

1819. *Hair grows by the roots.* In some species they are renewed annually; and in all they are readily reproduced.

1820. *Hair is the most permanent* of all the substances consisting of animal matter, resisting putrefaction for a great length of time.

1821. *Feathers* are nearly related to hairs; they consist of the quill, shaft, and web. The quill, like the hair, takes its rise in the cellular membrane: the central portion of the shaft has a texture like cork, and the web which usually occupies both sides of it is composed of what are called barbes, and the sides of these with barbules. Feathers exhibit great difference as to color: in some birds it varies with the seasons, in others with food, and in others with the extinction of life. Like hairs, feathers are not only renewed periodically, but they are readily reproduced, if accidentally destroyed.

1822. *Horns* take their rise in the same situation as hairs or feathers. They may be regarded as hairs agglutinated, and forming a hollow cone. The fibrous structure of horn may be perceived in many animals at the base, where it unites with the skin. At this part it receives the additions to its growth, the apex of the cone being pushed out in proportion as the increase takes place at the root, and on the inner surface. But horns differ remarkably from hair, in having their central cavity filled by a projection of bone or other solid substance from the body beneath.

1823. *The different markings of the horns,* particularly the transverse ridges, are indications of the different layers of growth; and in many cases the number of these ridges corresponds with the years of life.

1824. *The color of the horn* is, in general, distributed through the mass; sometimes, however, it is collected into bands or threads. It seldom experiences much change during the life of the animal. It is permanent, or does not experience those periodical renovations which we have stated to take place with hair and feathers. The deciduous horns of the stag are different in their nature from true horns, and will be afterwards taken notice of. The term horn is usually restricted to the coverings of the projections of the frontal bones of oxen, sheep, and similar quadrupeds; but various appendices of the skin, composed of the same materials, and equally permanent, although seated on other parts of the body, may with propriety be included under the same appellation; among these may be enumerated beaks, hoofs, claws, nails, and spurs.

1825. *Beaks.* The substance of these covers the external surface of the maxillary bones of birds, and is composed of horn.

1826. *Hoofs* resemble horns in their manner of growth, and in containing a central support, formed by the termination of the extreme bones of the feet. They grow from the inner surface and base, and are thus fitted to supply the place of those parts which are worn away by being exposed to friction against hard bodies. Hoofs are peculiar to certain herbivorous quadrupeds.

1827. *Claws* resemble hoofs in structure and situation, deriving their origin from the skin, having a bony centre, and occurring at the extremities of the fingers and toes.

1828. *Nails* differ from horns and claws, in the circumstance of not being tubular, but consisting of a plate generally convex on the outer surface, and concave beneath.

1829. *Spurs* occur chiefly on what is termed the leg (*tarsus*) of gallinaceous birds. They are found, likewise, on the ornithorynchus. Like horns, they are supported in the centre by bone.

1830. *Horns, hoofs, and similar parts,* bear a close resemblance to one another in chemical composition. When heated they soften, and may be easily bent or squeezed into particular shapes. They consist of coagulated albumen, with a little gelatine; and, when incinerated, yield a little phosphate of lime.

1831. *Their use,* in animal economy, is to protect the soft parts from being injured by pressure against hard bodies. They are in general wanting, where the parts are in no danger of suffering from the influence of such agents. When torn off from the base, they are seldom completely renewed, although very remarkable exertions are frequently made by the system to repair the loss.

1832. *Scales* vary remarkably in their form, structure, mode of adhesion, and situation in different animals. In general they are flat plates, variously marked. In some cases each scale consists of several plates, the lowest of which are largest; so that the upper surface becomes somewhat imbricated. Some scales adhere by the whole of their central surface; while others resemble the human nail, in having the distal extremity free.

1833. *Shells* consist of layers of an earthy salt, with interposed membranes of animal matter, resembling coagulated albumen. They grow by the addition of layers of new matter to the edges and internal surface. When broken, the animal can cement the edges and fill up the crack, or supply the deficiency when a portion is abstracted.

1834. *The earthy matter of shells* is lime, in union with carbonic acid. Phosphate of lime has likewise been detected, but in small quantity. The color is secreted from the animal, along with the matter of the shell.

1835. *Crusts* are, in general, more brittle in their texture than shell. They exhibit remarkable differences as to thickness and composition. They differ from shells chiefly in containing a considerable portion of phosphate of lime, and in a greater subdivision of parts. In some cases, however, as the crusts of the bodies of insects, the earthy matter is almost absent, and they may be regarded as formed of cuticle alone. When they contain much earthy matter, as in the crusts of lobsters, the epidermis may be detected as a cover, and the corium beneath may be perceived as a very thin film. In many cases, these crusts are renewed periodically; and, in all, they are readily repaired. Crusts occur in insects, the crustacea, and the echinodermata, or sea-urchins, and star-fish.

1836. *These different appendices of the skin* pass, by insensible degrees, into one another, as hair into spines, horns into nails, scales into shells, and crusts into membranes. They have all one common origin, namely, the skin; and independent of secondary purposes, they all serve for protection.

1837. *The secretions of the skin* are of three kinds, one class performing the office of lubricating the skin; another of regulating the temperature of the body; and a third of carrying off the superfluous carbon.

1838. *Unctuous secretions* are confined to animals which have warm blood, and the cells of the cellular web filled with fat, mammalia and birds.

1839. *Viscous secretions.* In the animals with cold blood, secretions are produced, by the skin, of substances differing in quality from those of warm-blooded animals; but destined to serve the same purposes, namely, to protect the skin from the action of the surrounding element.

1840. *Sweat*, in ordinary cases, exudes from the skin in a state of vapor; and when condensed consists of water with a small portion of acetic acid and common salt. This secretion is considered as intended to regulate the degree of animal heat, and prevent its accumulation beyond certain limits.

1841. *Carbon* is also emitted by the skin, and appears to be in effect a secondary kind of respiration, but the discovery is but recent. (See Ellis on the Germination of Seeds and Respiration of Animals, 1807 and 1811.)

1842. *Absorption.* There are several circumstances which prove, that the skin of the human body, in particular states, is capable of exerting an absorbing power. Whether the absorption takes place by peculiar vessels, or by the exhaling vessels having their motions reversed, or whether absorption ever takes place in the state of health, are questions to which no satisfactory answer has been given.

## SECT. II. Internal Anatomy of Animals.

1843. *Animal anatomy* admits of three divisions, the osseous, the muscular, and the nervous structure of animals.

### SUBSECT. 1. Osseous Structure of Animals.

1844. *The organs of external anatomy* are generally considered as destined for protection; while those of the interior of the animal, or the bones, give stability to the power, support the muscles, and afford levers for the execution of locomotion. Bones may be considered in regard to their composition, articulations, and arrangement. All bones are composed of the periosteum, cartilaginous basis, earthy matter and fat.

1845. *The periosteum* bears the same relation to the bone as the skin to the body, serving as a covering for its surface, and a sheath for the different cavities which enter it. It varies in thickness, according to the nature of the bone. Its texture is obviously fibrous; and it possesses blood vessels. Its sensibility indicates the existence of the nerves.

1846. *The cartilaginous basis* consists of gelatine and coagulated albumen. The earthy matter is chiefly phosphate of lime, and the fat resembles that of the fixed oils.

1847. *Bones increase in size*, not as in shells, scales, or horns, by the addition of layers to the internal surface, but by the expansion of the cartilaginous basis; which, when it becomes saturated with earthy matter, is incapable of farther enlargement. This is the reason why the bones of young animals are soft and flexible, while those of old animals are hard and brittle.

1848. *The proportion* between the cartilaginous basis, and the earthy matter differs, not only in every animal according to age, the earthy matter being smallest in youth, but, likewise, according to the nature of the bone itself, and the purposes which it is destined to serve. The teeth contain the largest portion of earthy matter. Remarkable differences are likewise observable, according to the class or species.



1849. *Bone is readily reproduced*, in small quantities, especially in youth. In the case of fracture, the periosteum inflames and swells, the crevice is filled up by a cartilaginous basis, abounding in vessels, and the earthy matter is at length deposited, giving to the fractured part, in many cases, a greater degree of strength than it originally possessed. In animals of the deer kind, the horns, which are true bone, are annually cast off; a natural joint forming at their base, between them and the bones of the cranium, with which they are connected. They are afterwards reproduced under a skin or periosteum, which the animal rubs off when the new horns have attained their proper size. In some cases of disease, the earthy matter is again absorbed into the system, the cartilaginous basis predominates, and the bones become soft and tender. This takes place in the disease of young termed *rickets*, and in a similar complaint of advanced life, known under the name of *mollities ossium*. In other instances, bone is formed as a monstrous production, in organs which do not produce it in a state of health, as the brain, the heart, and the placenta. (*Monro's Outlines of Anatomy*, p. 63.)

1850. *Cartilage* can scarcely be said to differ in its nature, from the cartilaginous basis of the bone. It is of a fine fibrous structure, smooth on the surface, and remarkably elastic. It covers those parts of bones which are exposed to friction, as the joints, and is thickest at the point of greatest pressure. By its smoothness, it facilitates the motion of the joints, and its elasticity prevents the bad effects of any violent concussion. It is intimately united with the bone, and can scarcely be regarded as different from an elongation of the cartilaginous basis. Where it occurs at a joint with considerable motion, it is termed *articular* or *obducent* cartilage. In other cases, it occurs as a connecting medium between bones which have no articular surfaces, but where a variable degree of motion is requisite. The ribs are united to the breast bone in this manner. Between the different vertebræ, there are interposed layers of cartilage, by which the motions of the spine are greatly facilitated. As these connecting cartilages are compressible and elastic, the spine is shortened when the body remains long in a vertical position, owing to the superincumbent pressure. Hence it is that the height of man is always less in the evening than in the morning. All these cartilages are more or less prone to ossification, in consequence of the deposition of earthy matter in the interstices. To this circumstance may be referred, in a great measure, the stiffness of age, the elasticity of the cartilages decreasing with the progress of ossification.

1851. *The articulations of bones*, exhibit such remarkable differences, in respect to surface, connection, and motion, that anatomists have found it difficult to give to each manner of union an appropriate name and character. We shall only notice the most obvious kinds and motions, and these admit of two divisions, the *true joints* and the *motionless junctions*.

1852. *In the motionless junctions*, the connecting surfaces come into close and permanent contact, as in the serrated edges of the bones of the human skull, or the even edges of the bones of the heads of quadrupeds and birds. Sometimes a pit in one bone receives the extremity of another like a wedge; as in the case of the human teeth: in other cases the one bone has a cavity with a protuberance at its centre, which receives another bone, as in the claws of cats, seals, &c. The human ribs are united with the breast-bone by the intervention of cartilage, as are the two sides of the lower jaw with such other in vertebral animals.

1853. *In true joints* the articular surfaces are enveloped with cartilage, remarkable for the smoothness of its free surface, and its intimate union with the bone, of which it forms a protecting covering. The periosteum is not continued over the surface of the cartilage, but is prolonged like a sheath over the joint, until it joins that of the opposite bone. It thus forms a close bag at the joint, in which nothing from without can enter, and from which nothing can escape. Into this bag the lubricating liquor termed *synovra* is conveyed. It is secreted by a mucous membrane on the interior, on which account, as it in some cases appears like little bags, the term *cursa mucosa* has been bestowed upon it.

1854. *Ligaments*. Besides the sheath formed by the continuation of the periosteum, and which is too slender to retain the bones in their proper place, the joints are furnished with *ligaments*. These are membranes of a dense fibrous texture, flexible, elastic, and possessed of great tenacity. They have their insertion in the periosteum and bone with which they are intimately united. The motions which joints of this kind are capable of performing, may be reduced to three kinds—flexion, twisting, and sliding. In *flexion*, the free extremity of the bone which is moved, approaches the bone which is fixed, describing the segment of a circle, whose centre is in the joint. In *twisting*, the bone which is moved turns round its own axis, passing through the articulation. In *sliding*, the free extremity of the bone moved, approaches the bone which is fixed, in a straight line.

#### SUBJECT. 2. Muscular Structure of Animals.

1855. *The muscles are the organs by which motion is executed*: they unfold the most singular mechanism of parts, and an infinite variety of movements. The muscles appear in the form of large bundles, consisting of cords. These, again, are formed of smaller threads, which are capable of division into the primary filaments. Each muscle, and all its component cords and filaments, is enveloped by a covering of cellular membrane, liberally supplied by blood-vessels and nerves.—At the extremities of the muscular fibres, where they are attached to the more solid parts, there are usually threads of a substance, differing in its appearance from the muscle, and denominated *tendon* or *sineu*. The tendons are, in general, of a silvery-white colour, a close, firm fibrous

texture, and possess great tenacity. The threads of which they consist, are attached on the one extremity to the surface of a bone, or other hard part; and on the other, they are variously interspersed among the fibres or bundles of the muscle. — They are considered as destitute of sensibility and irritability, and form a passive link between the muscle and the bone, or other point of support.

1856. *Muscles are the most active members of the animal frame.* They alone possess the power of irritability, and execute all the motions of the body. The causes which excite them to action, may be reduced to two kinds. In the first the will, through the medium of the nerves, excites the irritability of the fibres; and in the second, the action is produced by the application of external objects, either directly or by the medium of the nerves. The changes which take place in the tenacity of muscles after death, are very remarkable. The same force which they could resist with ease, in a living state, is sufficient to tear them to pieces after the vital principle has departed.

1857. *The functions of the muscles* are either those of rest or motion. Many animals protect themselves against the disturbing movements of the air and water, by placing their bodies in a *prone position*. To give still greater efficacy to this protecting attitude, they retire to valleys, woods or dens, on the earth, or to the deepest places in the waters; and are thus able, by the weight of their own bodies, and the advantage of their position, to outlive the elemental war. — But there are other animals, which, while they are equally cautious to make choice of proper situations for their safety, employ in addition, peculiar organs with which they are provided, to connect themselves more securely with the basis on which they rest.

1858. *Grasping.* — The most simple of these expedients, grasping, is displayed by bats, birds and insects, in the employment of their toes, with their claws, in seizing the objects of their support. In birds, the assumption and continuance of this attitude is accomplished by a mechanical process; so that there is no expenditure of muscular energy. In every case of this kind, the claws are so admirably adapted to the station of the animal, that the detention of the body in the same spot during this state of rest, is accompanied with little exertion.

1859. *Suction.* — The third method of fixing themselves employed by animals, is *suction*. The sucker varies greatly in its form, and even structure. In the limpet, and other gasteropodous mollusca, its surface is smooth and uniform; and the adhesion appears to depend on its close application to every part of the opposing surface. In other animals, as the leech and the sea-urchin, the sucker is formed at the extremity of a tube; the muscular motions of which may serve to pump out any air which may remain, after the organ has been applied to the surface of the body.

1860. *Cementation.* — The fourth method, termed *cementation*, employed by animals to preserve themselves stationary, consists in a part of their own bodies being cemented to the substance on which they rest. This takes place in the common mussel, by means of strong cartilaginous filaments, termed the *byssus*, united in the body to a secreting gland, furnished with powerful muscles, and, at the other extremity, glued to the rock or other body to which it connects itself. In other cases, as in the oyster, the shell itself is cemented to the rock.

1861. *The muscular motions of animals* are standing, walking, leaping, flying, and swimming.

1862. *In standing* it is necessary that the parts of the body be so disposed, as that the centre of gravity of the whole body fall within the space which they occupy, and that the muscles have sufficient power to counteract those movements which might displace the body from that position. It is obvious that the more numerous the limbs, and the more equally they are distributed on the inferior side of the body, the more securely will the centre of gravity be retained within the space which these feet include.

1863. *Walking* is defined by Cuvier, to be a motion on a fixed surface, in which the centre of gravity is alternately moved by one part of the extremities, and sustained by the other, the body never being at any time completely suspended over the ground. It is produced by the alternate flexion and extension of the limbs, aided by the motions of the trunk, advancing the position of the centre of gravity in the intended direction.

1864. *In animals with many feet*, as the *myriapoda*, walking is performed by so uniform a motion, that the body may be said to glide along the surface.

1865. *In animals with four feet*, "each step is executed by two legs only; one belonging to the fore pair, and the other to the hind pair; but sometimes they are those of the same side, and sometimes those of the opposite side." (*Cuvier's Comparative Anatomy*, Lect. vii. a. 1.) The latter is that kind of motion in horses, which grooms term a *pace*. The right fore-leg is advanced so as to sustain the body, which is thrown upon it by the left hind-foot, and at the same time, the latter bends in order to its being moved forward. While they are off the ground, the right-hind foot begins to extend itself, and the moment they touch the ground, the left fore-foot moves forward to support the impulse of the right foot, which likewise moves forward. The body is thus supported alternately by two legs placed in a diagonal manner. When the right fore-foot moves, in order to sustain the body, pushed forward by the right hind-foot, the motion is then called an *amble*. The body, being alternately supported by two legs on the same side, is obliged to balance itself to the right and left, in order to avoid falling; and it is this balancing movement which renders the gait so soft and agreeable to women and persons in a weak state of body. (*Cuvier's Comp. Anat.* Lect. vii.)

1866. *The serpentine motion* consists in bringing up the tail towards the head by bending the body into one or more curves, then resting upon the tail, and extending the body, thus moving forward, at each step, nearly the whole length of the body, or one or more of the curves into which it was formed. Among the mollusca, and many of the annulose animals, the same kind of motion is performed by alternate contractions and expansions, laterally and longitudinally of the whole body, or of those parts which are appropriated to progressive motion.

1867. *A mode of moving analogous to walking*, is performed by animals who have suckers, and is exemplified in the leech, which at every step advances nearly the whole length of its body.

1868. *In the action of leaping*, the whole body rises from the ground; and for a short period is suspended in the air. It is produced by the sudden extension of the limbs, after they have undergone an unusual degree of flexion. The extent of the leap depends on the form and size of the body, the length and strength of the limbs. The *myriapoda* are not observed to leap. Many of the spiders and insects leap with ease both

forwards, backwards, and laterally. In those, which are remarkable for this faculty, the thighs of the hind-legs are in general of uncommon size and strength. Among reptiles the leaping frog is well known, in opposition to the crawling toad. Among quadrupeds, those are observed to leap best, which have the hind legs longer and thicker than the fore legs, as the kangaroo and the hare. These walk with difficulty, but leap with ease.

1869. *Scorpents* are said to leap, by folding their bodies into several undulations, which they unbend all at once, according as they wish to give more or less velocity to their motion. The jumping maggot, found in cheese, erects itself upon its anus, then forms its body into a circle, bringing its head to the tail; and, having contracted every part as much as possible, unbends with a sudden jerk, and darts forward to a surprising distance. Many crabs and poduræ bend their tail, or hairs which supply its place, under their belly, and then suddenly unbending, give to the body a considerable degree of progressive motion.

1870. *Flying*.—Flying is the continued suspension and progress of the whole body in the air, by the action of the wings. In leaping, the body is equally suspended in the air, but the suspension is only momentary. In flying, on the contrary, the body remains in the air, and acquires a progressive motion by repeated strokes of the wings on the surrounding fluid. The centre of gravity of the bodies of flying animals, is always below the insertion of the wings, to prevent them falling on their backs, but near that point on which the body is, during flight, as it were suspended. The action of flying is performed by animals belonging to different classes. Among the Mammalia, bats display this faculty, by means of wings, formed of a thin membrane extending between the toes, which are long and spreading, the fore and hind legs, and between the hind legs and the tail. In birds, the wings, which occupy the place of the anterior extremities in the mammalia, and are the organs of flight, consist of feathers, which are stronger than those on the body, and of greater length. Among reptiles, the flying lizard may be mentioned, whose membranaceous wings, projecting from each side of the body, without being connected with the legs, enable it to fly from one tree to another in search of food. A few fishes are likewise capable of sustaining themselves for a short time by means of their fins; these are termed flying fish. Spiders are able to move in the air by means of their threads.

1871. *Swimming* is the same kind of action in water, as flying is in air. The organs which are employed for this purpose, resemble the oars of a boat in their mode of action, and in general possess a considerable extent of surface and freedom of motion. Swimming, however, is not confined to those animals which are furnished with oars or swimmers. Many animals move with ease in the water by means of repeated undulations of the body, as serpents, eels, and leeches; or by varying the form of the body by alternate contractile and expansive movements, as the medusæ.

1872. In these *different displays of voluntary motion*, the muscles are only able to continue in exercise for a limited period, during which their irritability diminishes, and the further exertion of their powers becomes painful. When thus fatigued, animals endeavor to place themselves in a condition for resting, and fall into that state of temporary lethargy, denominated *sleep*.

1873. *The positions assumed by animals during sleep*, are extremely various. In the horse, they even differ according to circumstances. In the field he lies down, in the stable he stands. Dogs and cats form their bodies into a circle, while birds place their heads under their wings.

1874. *The ordinary shape of sleep* is likewise exceedingly various in different animals, and in the same animal is greatly influenced by habit. It in general depends on circumstances connected with food. It is probable, that all animals, however low in the scale, have their stated intervals of repose, although we are as yet unacquainted either with the position which many of them assume, or the periods during which they repose.

### SUBJECT. 3. *Structure of the Nervous System.*

1875. *The nervous system*, by containing the organs of sensation and volition, is that which distinguishes animal from vegetable beings. It consists in the vertebral animals, of the brain, the spinal marrow, and the nerves.

1876. *The brain*, exclusive of its integuments, appears in the form of a soft, compressible, slightly viscous mass. The spinal marrow originates with the brain, and consists of four cords united in one body. The nerves, also, originate in the brain or spinal marrow. Some of them appear to have a simple origin; but in general, several filaments, from different parts of the brain or spinal marrow, unite to form the trunk of a nerve. This trunk again subdivides in various ways; but the ramifications do not always exhibit a proportional decrease of size. It frequently happens, that the branches of the same or of different nerves unite and separate repeatedly within a small space, forming a kind of net-work, to which the name *plexus* has been applied. Sometimes filaments pass from one nerve to another; and, at the junction, there is usually an enlargement of medullary matter termed a *ganglion*. Numerous filaments, from different nerves, often

unite to form a ganglion, from which proceed trunks frequently of greater magnitude than the filaments which entered. Thus nerves, very different in their origin, form communications with one another; so that the whole nervous system may be considered as a kind of net-work, between the different parts of which an intimate connection subsists. In consequence of this arrangement, it is often matter of very great difficulty to ascertain the *origin* of those filaments, which unite to constitute the trunk of a nerve. In some instances, they appear to arise from the surface of the brain or spinal marrow; in other cases, from the more central parts.

1877. *The brain in the animals without vertebræ*, is destitute of the protecting bony covering, which forms the head and back bone in the vertebral animals. The brain itself is much more simple in its structure. Independent of very remarkable differences in the structure of the nervous system in the different genera of invertebral animals, there may still be perceived two models, according to which, the organs belonging to it are arranged. In the first, the brain is situated upon the œsophagus. It presents different forms, according to the species. It appears more like a ganglion, than the brain of the vertebral animals. It sends off several nerves to the mouth, eyes, and feelers. One on each side passes round the œsophagus; these uniting below, form a ganglion; in some cases, larger than what is considered the true brain. From this ganglion, nerves are likewise sent off to different parts of the body. The animals in which this nervous system prevails, belonged to the great division termed Mollusca. In the second, the brain is situated as in the mollusca, sends out nerves to the surrounding parts, and likewise one nerve on each side, which, by their union, form a ganglion, from which other nerves issue. This ganglion produces likewise a nervous cord, which proceeds towards the extremity of the body, forming throughout its length ganglia, from which small nerves proceed; this cord, at its commencement, is, in some cases, double for a short distance. It has been compared to the medulla oblongata, and spinal marrow of the vertebral animals. This kind of nervous system is peculiar to the annulose animals. There are usually ganglia on the nervous cord, corresponding with the number of rings of which the body consists.

1878. *The functions of the brain and nervous system*; the organs of perception, as of touch, of heat, of light, of hearing, of smell, and of taste; and also the faculties of the mind, we pass over as belonging chiefly to the anatomy and physiology of the human frame, and therefore less immediately connected with the animals used in agriculture. The reader will find these subjects ably treated by Dr. Fleming.

### CHAP. III.

#### *Animal Chemistry; or the Substances which enter into the Composition of the Bodies of Animals.*

1879. *The elementary principles of the animal kingdom* have been ascertained with considerable precision; but the binary, ternary, or other compounds which these form, have not been investigated with so much success. As these various ingredients are brought into union in the animal system by the agency of the vital principle, their state of combination may be expected to differ widely from the ordinary results of electric attraction. When such compounds of organization are submitted to analysis, the influence of the vital principle having ceased, the products obtained may be regarded, in many cases, as modifications of the elements of the substance, occasioned by the processes employed, rather than the display of the number or nature of the ingredients, as they existed previous to the analytical operations. Hence the great caution requisite in drawing conclusions regarding the composition of animal bodies.

1880. *The elementary substances which are considered as entering into the parts of animals*, are carbon, hydrogen, oxygen, azote, phosphorus, sulphur, fluoric acid, muriatic acid, iodine, potash, soda, ammonia, lime, magnesia, silica, iron, and manganese.

1881. *Carbon* exists in various states of combination in the fluids as well as the solids of every animal, and has been detected in the form of charcoal in the lungs. When animal substances are exposed to a high temperature in closed vessels, the charcoal which is produced differs considerably from that which is obtained by the same means from vegetables. It is more glossy in appearance, and is incinerated with much greater difficulty.

1882. *Hydrogen* is universally distributed in the animal kingdom; it occurs as a constituent ingredient of all the fluids, and of many of the solids. It is invariably in a state of combination with charcoal; for, as far as we know, it has never been detected in an uncombined or separate state. It has been found in the human intestines, in the form of carburetted hydrogen.

1883. *Oxygen* is equally widely distributed with the preceding, in the fluids and solids of all animals. A constant supply of it from the atmosphere is indispensably necessary to the continuation of animal life. It occurs, not only in combination with other bodies, but probably, likewise in a separate state, in the air-bag of fishes, in which it is found, varying in quantity, according to the species, and the depth at which the fishes have been caught. It is common, in union with charcoal, forming *carbonic acid*.

1884. *Azotic gas* is very widely distributed as a component part of animal substances. It occurs in almost all the fluids, and in those solid parts which have carbon as a base. The almost universal prevalence of this principle in animal substances, constitutes one of the most certain marks by which they may be distin-

guished from vegetables. Azote likewise occurs, in an uncombined state, in the air-bag of some fishes.

1885. *Phosphorus*. This inflammable body exists, in union with oxygen, in the state of phosphoric acid, in many of the solids and fluids of animals. Its existence, however, in an uncombined state, has not been satisfactorily determined, although there appears a tendency to refer the luminousness of several animals to the slow combustion of this substance. Even phosphoric acid can scarcely be said to exist in a separate state, being found in combination with potash, soda, ammonia, lime, or magnesia.

1886. *Sulphur*, in combination, exists in considerable abundance in animal substances. It can scarcely be said to occur in a separate state in animals; at least the experiments which may be quoted as encouraging such a supposition, are by no means decisive. United with oxygen, in the form of sulphuric acid, it exists in combination with potash, soda, and lime.

1887. *Fluoric acid* has been detected in bones and urine, in a state of combination with lime.

1888. *Muriatic acid* exists in a great number of the animal fluids, in combination with an alkali, as in the ammonia and soda of urine.

1889. *Iodine* has been detected in sponge.

1890. *Potash* exists in combination with the sulphuric, muriatic, or phosphoric acids; but it is far from abundant in animal fluids.

1891. *Soda* is present in all the fluids in various states of combination, and is more abundant than the preceding. It gives to many of the secretions the alkaline property of changing vegetable blues into green. It is found in union with the carbonic, phosphoric, sulphuric, and muriatic acids.

1892. *Ammonia* exists in its elements in all the fluids, and many of the solids of animals, and is frequently produced during putrefaction. These elements are likewise found united in the system, and the alkali then appears in union with the various acids, as the phosphoric, muriatic, and lactic.

1893. *Lime*, of which the hard parts of animals, such as bones and shells, are chiefly composed, is of universal occurrence. It is always in a state of combination, and chiefly with the carbonic or phosphoric acids.

1894. *Magnesia* occurs sparingly. It has been detected in the bones, blood, and some other substances, but always in small quantity, and chiefly in union with phosphoric acid.

1895. *Silica* occurs more sparingly than the preceding. It is found in the hair, urine, and urinary calculi.

1896. *Iron* has hitherto only been detected in the coloring matter of the blood, in bile, and in milk. Its peculiar state of combination in the blood has given rise to various conjectures; but a satisfactory solution of the question has not yet been obtained. In milk, it appears to be in the state of phosphate.

1897. *Manganese*, in oxide, has been observed, along with iron, in the ashes of hair.

1898. Such are the simple substances which have been detected by chemists in the solids and fluids of animals; but seldom in a free state, and often in such various proportions of combination as renders it extremely difficult to determine their true condition.

1899. The compounds of organization are gelatine, albumen, fibrin, mucus, urea, sugar, oils, and acids.

1900. *Gelatine* occurs in nearly a pure state in the air-bags of different kinds of fishes, as, for example, isinglass, dissolved in hot water and allowed to cool, forms jelly. When a solution of tannin is dropped into a solution of gelatine, an union takes place, and an insoluble precipitate of a whitish color falls to the bottom. It is on the union of the tannin of the oak bark with the gelatine of the hides, that the process of tanning leather depends. Gelatine exists in abundance in different parts of animals, as bones, muscles, skin, ligaments, membranes, and blood. It is obtained from these substances, by boiling them in warm water; removing the impurities, by skimming, as they rise to the surface; or by subsequent straining and clarifying. It is then boiled to a proper consistency. It is the characteristic ingredient of the softest and most flexible parts of animals.

1901. *Gelatine is extensively used in the arts*, under the names of glue and size, on account of its adhesive quality, and to give the requisite stiffness to certain articles of manufacture. In domestic economy, it is likewise employed in the form of jelly, and in the formation of various kinds of soup. What is termed *Portable Soup* is merely jelly which has been dried, having been previously seasoned, according to the taste, with different spices.

1902. *Albumen*, the white of an egg, exists in great abundance, both in a coagulated and liquid state, in the different parts of animals. Hair, nails, and horn, are composed of it. It appears likewise as a constituent of bone and shells; and there are few of the fluid or soft part of animals, in which it does not exist in abundance; what has hitherto been termed the *Resin of Bile*, is, according to Berzelius, analogous to albumen.

1903. *Albumen is extensively used in the arts*. When spread thin on any body, it soon dries, and forms a coating of varnish. Its adhesive power is likewise considerable. When rubbed on leather, it increases its suppleness. But its chief use is in clarifying liquors. For this purpose, any substance abounding in albumen, as the white of eggs, or the serum of blood, is mixed with the liquid, and the whole heated to near the boiling point. The albumen coagulates, and falls to the bottom, carrying along with it the impurities which were suspended in the fluid, and which rendered it muddy. If the liquor contains alcohol, the application of heat is unnecessary.

1904. *Fibrin* exists in the blood, and was formerly called the fibrous part of the blood. It likewise exists in all muscles, forming the essential part or basis of these organs. It exhibits many remarkable varieties, as it appears in the flesh of quadrupeds, birds, and fishes; but has not hitherto been turned to any particular use.

1905. *Extractive* exists in the muscles of animals, in the blood and in the brain. It communicates the peculiar flavor of meat to soups. In the opinion of Fourcroy, the brown crust of roasted meat consists of it.

1906. The soft parts of animals are constituted of these four substances, which also enter into the composition of the hard parts and of the fluids. They are readily distinguishable from one another. Extractive alone is soluble in alcohol; gelatine is insoluble in cold, but soluble in hot water; albumen is soluble in cold, and insoluble in hot water; the fibrin is equally insoluble in hot and cold water. They are variously mixed or united; and as they consist of some elementary principles, chiefly carbon,

hydrogen, oxygen, and azote, it is probable that they are changed, the one into the other, in many cases by the living principle, — a transmutation which the chemist has succeeded in accomplishing, and which may soon be of advantage in the arts. The proportion of carbon appears to be least in gelatine and greatest in fibrin.

1907. *Mucus* occurs in a liquid state in the animal economy, as a protecting covering to different organs. It necessarily differs in its qualities, according to the purposes it is destined to serve. In the nose it defends the organ of smell from the drying influence of the air, — in the bladder, it protects the interior from the contact of the acid urine, — while it preserves the gall-bladder from the action of alkaline bile. It does not contain any suspended particles like the blood, but is homogeneous. (*Dr. Young, Annals of Phil.* ii. p. 117.) When inspissated, it constitutes, in the opinion of some, the basis of the epidermis, horns, nails, feathers. But the difficulty of obtaining it in a pure state, and the discordant characters assigned to it by different chemists, prevent us from reposing confidence in the accuracy of the analysis of those substances, of which it is considered as forming an essential ingredient.

1908. *Urea* is a substance obtained by evaporation and trituration from the urine of the mammalia when in a state of health. In the human subject it is less abundant after a meal, and nearly disappears in the disease called diabetes, and in affections of the liver.

1909. *Sugar* exists in considerable abundance in milk, and in the urine of persons laboring under diabetes. In the latter fluid, it is to be considered as a morbid secretion of the kidneys, occupying the natural situation of the urea. In milk, however, it exists as a constituent principle, and may readily be obtained by the following process: evaporate fresh whey to the consistence of honey, dissolve it in water, clarify with the whites of eggs, and again evaporate to the consistence of syrup. On cooling, white cubical crystals will be obtained, but less sweet than vegetable sugar.

1910. *Oils* vary greatly as to colour, consistence, smell and other characters. They possess, however, in common, the properties of the fixed oils, in being liquid, either naturally or when exposed to a gentle heat, insoluble in water and alcohol, leaving a greasy stain upon paper, and being highly combustible. They are distinguished as spermaceti, ambergrease, fat, and common oils.

1911. *Spermaceti* constitutes the principal part of the brain of the whale, and is freed from the oil which accompanies it, by draining and squeezing, and afterwards, by the employment of an alkaline lie, which saponifies the remainder. It is then washed in water, cut into thin pieces with a wooden knife, and exposed to the air to dry. It is used in medicine and candlemaking.

1912. *Amergrease* is found in the intestines of the spermaceti whale, and in those only which are in a sickly state. It appears to be the excrement, altered by a long retention in the intestines, and therefore scarcely merits a place among the natural ingredients of the animal system. Upon being voided by the animal, it floats on the surface of the sea, and has been found in various quarters of the globe. It usually contains the beaks of cuttle fish adhering to it. It is employed in small quantities by druggists and perfumers.

1913. *Fat* consists of two substances, suet and oil. It is usually purified by separating the vessels and membranes which adhere to it, by repeatedly washing with cold water, and afterwards melting it, along with boiling water.

1914. *Tallow* is the fat of ruminating animals, and is hard and brittle, while the fat of the hog, called *lard*, is soft and semifluid. Its uses as an article of food, in the making of candles, hard soap, and ointments, and to diminish friction, are well known.

1915. *The properties of oils* depends in a great degree on the mode of preparation, with the exception of the odor, which arises from the kind of animal from which the oil has been derived. *Spermaceti oil* is considered as the thinnest of the animal oils, and the fittest for burning in lamps. It is obtained from the spermaceti, by draining and pressure. *Train oil* is procured by melting the blubber, or external layer of fat, found underneath the skin of different kinds of whales and seals. From the process employed, it contains, besides the oil, gelatine, albumen, and other animal matters, which render it thick, dark-colored, and disposed to become rancid. *Fish oil* is sometimes extracted from the entire fish, (as the sprat, pilchard, and herring, when they occur in too great quantities to be salted) by boiling in water, and skimming off the oil, as it appears on the surface. In general, however, the oil is obtained from the livers of fish, in which it is lodged in cells.

1916. The *acids* found in animals consist of various proportions of carbon, hydrogen, oxygen, and azote. Some of them are peculiar to the animal kingdom, and others exist in equal abundance in plants.

1917. *The uric or lithic acid*, abounds in urine, and appears to be a production of the kidneys. The *lactic acid* is common in the animal fluids. The *amniotic acid* has been found in the uterus of a cow. The *formic acid*, by distilling ants. The *benzoic, oxalic, acetic, and malic acids*, are common both to plants and animals, but occur but seldom in the latter.

1918. These *elementary substances*, by combining in different proportions, exhibit a great variety of separate substances. The earthy salts are likewise abundant; and when they occur in a separate state, they strengthen the albuminous framework, and form the skeleton, giving stability to the body, and acting as levers to the muscles. The alkaline salts occur in the greatest abundance in the secreted fluids.

1919. The *fluids* consist of those juices which are obtained from our food and drink, such as the chyle, and are termed *crude of the blood*; or prepared from the crude fluids, and destined to communicate to every part of the body, the nourishment which it requires, and of those fluids which are separated from the blood, in the course of circulation, such

as the bile, and termed secreted fluids. These are all contained in appropriate vessels, and are subject to motion and change.

1920. The *solids* are derived from the fluids, and are usually divided into the soft and hard. The soft solids consist chiefly of what is termed animal matter, of combinations of carbon, hydrogen, oxygen, and azote. They consist of fibres, which are usually grouped into faggots; of plates, which, crossing one another in various directions, give rise to cellular structure, or of a uniform pulpy mass.

1921. *The fibrous texture* may be observed in all the muscles, tendons, and ligaments, and in the bones of many animals, especially before birth. These fibres, however minutely divided, do not appear to be hollow, like those of the vegetable kingdom.

1922. *The cellular texture* is universally distributed in the form of membranes, which invest every organ, the bundles of fibres in every muscle, and, by forming tubes with the addition of the fibrous texture, constitute the containing vessels. The substance gives form to all the different parts, and is that particular portion which is first formed, and which constitutes the frame on and within which the other materials of the system are deposited. It readily expands by the increase of its contents; and, with equal ease, contracts when the distending cause is removed.

1923. *The pulpy texture* is confined to the brain and nerves, the liver, kidneys, and other secreting organs of the system. Its composition appears to the eye homogeneous, and its form is regulated by its cellular envelope.

1924. *These soft solids* are alone capable of possessing the faculty of sensation. By their aid, the nervous energy is exerted on the different parts of the body; and, through them, the impressions of external objects are received.

1925. *The hard solids* consist either of cartilage, which resembles, in its qualities, coagulated albumen; or of bone, formed by various combinations of earthy salts. They are destitute of sensation, and are chiefly employed in defending the system from injury, giving it the requisite stability, and assisting the muscles in the execution of their movements.

1926. *The proportion between the solids and fluids* is not only remarkably different in different species, but in the same species, in the various stages of growth.

## CHAP. IV.

### *Animal Physiology.*

1927. *The digestive circulation and reproductive functions of animals* come next in order.

#### SECT. I. *Of the Digestive System.*

1928. *The instinct of animals for food*, presides over the organs of the stomach. Hunger is felt when the stomach is empty; it is promoted by exercise, cold air applied to the skin, and cold, acid, or astringent fluids introduced into the stomach. Inactivity, warm covering, the attention diverted, and warm fluids, have a tendency to allay the sensation.

1929. *Thirst* is accompanied with a sensation of dryness in the mouth. This dryness may be occasioned by excessive expenditure of the fluids, in consequence of the dryness or saltiness of the food which has been swallowed; or to their deficiency, from the state of the organs.

1930. *Both hunger and thirst*, besides being greatly influenced by habit, exhibit very remarkable peculiarities according to the species and tribes of animals.

1931. Those which live on the spoils of the animal kingdom are said to be carnivorous, when they feed on flesh; piscivorous, when they subsist on fishes; and insectivorous, when they prey on insects. Again those animals which are phytivorous, or subsist on the products of the vegetable kingdom, are either granivorous and feed on seeds; graminivorous, pasturing on grass; or herbivorous, browsing on twigs and shrubs.

1932. *Besides those substances which animals make use of as food, water is likewise employed as drink*, and as the vehicle of nutritious matter. Salt is necessarily mixed with the drink of the inhabitants of the ocean, and is relished by man and many other animals. Other inorganic substances are likewise employed for a variety of purposes. Many savages make use of steatite and clay along with their food: The common earthworm swallows the soil, from which, in its passage through the intestines, it extracts its nourishment.

1933. *In some cases, substances are swallowed for other purposes than nourishment.* Stones are retained in the stomach of birds to assist in triturating the grain. The wolf is said to satisfy his hunger, by filling his stomach with mud.

#### SECT. II. *Of the Circulating System.*

1934. *The food being reduced to a pulvaceous mass*, and mixed with a variety of secreted fluids, by means of the digestive organs, is in this state denominated chyme. This mixture exhibits a chemical constitution nearly approaching that of blood, into which it is destined to be converted, by the separation of the useless from the useful part. This is effected by certain vessels called lacteals, which absorb the nutritious part of the chyme, and convey it to a particular receptacle. Another set of absorbents, the lymphatics, take up all the substances which have been ejected from the circulation, and which are no longer necessary in the particular organs, and communicate their contents to the store already provided by the lacteals. The veins receive the altered blood from the extremities of the arteries or the glands, in which they terminate, and proceed with it towards

the lungs, to be again aerated. In their progress, they obtain the collected fluid of the other absorbents, and, in the lungs, again prepare the whole for the use of the system. Thus, during the continuance of life, the arteries supply the materials by which the system is invigorated and enlarged, and oppose that tendency to decay, produced by the influence of external objects. The process continues during the whole of life, new matter is daily added, while part of the old and useless is abstracted. The addition is greatest in early life, the abstraction is greatest in old age.

1935. This *continued system of addition and subtraction* has led some to conclude, that a change in the corporeal identity of the body takes place repeatedly during the continuance of life, that none of the particles of which it consisted in youth, remain in its composition in old age. Some have considered the change effected every three, others every seven years. This opinion, however, is rendered doubtful by many well known facts. Letters marked on the skin by a variety of substances, frequently last for life. There are some diseases, such as small-pox and measles, of which the constitution is only *once* susceptible; but it is observed to be liable to the attack of these diseases, at every period of human life.

### SECT. III. *Of the reproductive System of Animals.*

1936. *Animals are reproduced in consequence of the functions of certain organs*, with the exception of some of the very lowest in the scale. In those animals which possess peculiar organs for the preparation of the germ or ovum, some are androgynous, (man-woman) and either have the sexual organs incorporated, and capable of generating without assistance, or the sexual organs are distinct, and the union of two individuals is necessary for mutual impregnation: others have the sexual organs separate, and on different individuals. The young of such animals are either nourished at first by the store of food in the egg, or by the circulating juices of the mother. Those species in which the former arrangement prevails, are termed oviparous, while the term viviparous is restricted to the latter.

1937. *In all animals it is the business of the female to prepare the ovum or germ*, and bring it to maturity. For this purpose, the germ is produced in the ovarium, farther perfected in the uterus or matrix, and finally expelled from the system through the vagina. The office of the male is to impregnate the germ by means of the spermatic fluid. This fluid is secreted in the testicles, transmitted by the spermatic ducts, and finally conveyed by the external organ to its ultimate destination.

1938. Among the *viviparous animals*, the reproductive organs present many points of resemblance, and appear to be constructed according to a common model. It is otherwise with the sexual organs of the oviparous tribes. They exhibit such remarkable differences in the form and structure of all their organs, that it is impossible to collect them into natural groups, or assign to them characters which they have in common.

1939. *The manner in which the eggs of birds are impregnated* by the male, has not been satisfactorily determined. With the exception of the cicatricula, a female bird, in the absence of the male, can produce an egg. The conjunction of the sexes, however, is necessary for the impregnation of the egg, and the effect is produced previous to the exclusion.

1940. In *many kinds of fishes and reptiles*, the yolks, after being furnished with their glaire, are ejected from the body of the female, and the impregnating fluid in the male is afterwards poured over them. Impregnation can be effected readily in such cases, by the artificial application of the spermatic fluid.

1941. *Impregnation in insects* appears to take place while the eggs pass a reservoir containing the sperm, situated near the termination of the oviduct in the volva.

1942. *The most simple mode of hatching* is effected by the situation in which the eggs are placed by the mother, after or during their exclusion. In this mode, a place is usually selected where the eggs will be exposed to a suitable and uniform temperature, and where a convenient supply of food may be easily obtained for the young animals. Such arrangements prevail in the insect tribe.

1943. In the *second mode*, the mother, aided in some cases by the sire, forms a nest, in which she deposits her eggs, and, sitting upon them, aids their hatching by the heat of her body. Birds in general hatch their young in this manner.

1944. In the *last mode*, the eggs are retained in the uterus, without any connexion, however, by circulating vessels, until the period when they are ready to be hatched, when egg and young are expelled at the same time. This takes place in some sharks and mollusca. The animals which exercise this last kind of incubation, are termed ovoviviparous. In the rana pipa, the eggs are deposited in a bag on the back, where they are hatched, and where the young animals reside for some time after birth. Some animals, as the aphid, are oviparous at one season, and ovoviviparous at another.

1945. *The young after being hatched*, are, in many cases, independent of their parent, and do not stand in need of any assistance: they are born in the midst of plenty, and have organs adapted to the supply of their wants. Thus, many insects are hatched on, or within the very leaves which they are afterwards to devour. In other cases, the young are able to follow their parents, and receive from them a supply of appropriate food; or if unable to follow, their parents bring their food to the nests.

1946. *The changes which the young of oviparous animals undergo in passing from infancy to maturity*, have long attracted the notice of the inquisitive observer. The egg of the frog is hatched in the water, and the young animal spends in that element a part of its youth. While there it is furnished with a tail and external bronchiae: both of which are absorbed, and disappear, when it becomes an inhabitant of the land. The infancy of the butterfly is spent in the caterpillar-state, with organs of motion and mastication which are peculiar to that period. It is destined to endure a second hatching, by becoming enveloped in a covering, and suffering a transformation of parts previous to appearing in its state of maturity. These metamorphoses of oviparous animals present an almost infinite variety of degrees of change, differing in character according to the tribes or genera.

1947. In *birds*, it is well known that one sexual union suffices for the production of impregnated eggs during the period of laying. This is a case somewhat analogous to those quadrupeds which produce several young at a birth with one impregnation, differing, however, in the circumstance that the eggs are



not all produced at the same time, although they are afterwards hatched by the same incubation. In the *aphides*, or plant-lice, as they are called, one impregnation not only renders fertile the eggs of the individual, but the animals produced from these, and the eggs of those again, unto the ninth generation.

1948. *Androgynous animals* are of two kinds; those where impregnation takes place by the mutual application of the sexual organs of two individuals; and those where the hermaphroditism is complete. The mollusca exhibit examples of both kinds.

1949. *Gemmparous animals* are exemplified in the hydra or fresh water polypus, and other zoophytes.

1950. *Hybridous animals*. In the accomplishment of the important purpose of generation, it is observed, that in the season of love, individuals of a particular species are drawn together by mutual sympathy, and excited to action by a common propensity. The produce of a conjunction between individuals of the same species partakes of the characters common to the species, and exhibits in due time the characteristic marks of puberty and fertility. In a natural state, the selective attribute of the procreative instinct unerringly guides the individuals of a species towards each other, and a preventive aversion turns them with disgust from those of another kind. In a domesticated state, where numerous instincts are suppressed, and where others are fostered to excess, individuals belonging to different species are sometimes known to lay aside their natural aversion, and to unite in the business of propagation. Instances of this kind occur among quadrupeds, birds, and fishes, among viviparous and oviparous animals, where impregnation takes place within, as well as when it is affected without the body. The product of such an unnatural union is termed a hybridous animal. The following circumstances appear to be connected with hybridous productions.

1951. *The parents must belong to the same natural genus or family*. There are no exceptions to this law. Where the species differ greatly in manners and structure, no constraints or habits of domestication will force the unnatural union. On the other hand, sexual union sometimes takes place among individuals of nearly related species. Thus, among quadrupeds, the mule is the produce of the union of the horse and the ass. The jackall and the wolf both breed with the dog. Among birds, the canary and goldfinch breed together, the Muscovy and common duck, and the pheasant and hen. Among fishes, the carp has been known to breed with the tench, the crusian, and even the trout. (*Phil. Trans.* 1771. p. 318.)

1952. *The parents must be in a confined or domesticated state*. In all those hybridous productions which have yet been obtained, there is no example of individuals of one species giving a sexual preference to those of another. Among quadrupeds and birds, those individuals of different species which have united, have been confined and excluded from all intercourse with those of their own kind. In the case of hybridous fishes, the ponds in which they have been produced have been small and overstocked, and no natural proportion observed between the males and females of the different kind. As the impregnating fluid, in such situations, is spread over the eggs after exclusion, a portion of it belonging to one species may have come in contact with the impregnated eggs of another species, by the accidental movements of the water, and not in consequence of any unnatural effort. In all cases of this unnatural union among birds or quadrupeds, a considerable degree of aversion is always exhibited, a circumstance which never occurs among individuals of the same species.

1953. *The hybridous products are barren*. The peculiar circumstances which are required to bring about a sexual union between individuals of different species, sufficiently account for the total absence of hybridous productions in a wild state. And, as if to preserve even in a domesticated state the introduction and extension of spurious breeds, such hybridous animals, though in many cases disposed to sexual union, are incapable of breeding. There are, indeed, some statements which render it probable that hybrid animals have procreated with perfect ones; at the same time there are few which are above suspicion.

---

## CHAP. V.

### *Animal Pathology; or the Duration, Diseases, and Casualties of Animal Life.*

1954. *Each species of animal is destined, in the absence of disease and accidents, to enjoy existence during a particular period*. In no species, however, is this term absolutely limited, as we find some individuals outliving others, by a considerable fraction of their whole lifetime. In order to find the ordinary duration of life of any species, therefore, we must take the average of the lives of a number of individuals, and rest satisfied with the approximation to truth which can thus be obtained. There is little resemblance in respect of longevity between the different classes, or even species of animals. There is no peculiar structure, by which long-lived species may be distinguished from those that are short-lived. Many species whose structure is complicated, live but for a few years, as the rabbit, while some of the testaceous mollusca, with more simple organization, have a more extended existence. If longevity is not influenced by structure, neither is it modified by the size of the species. While the horse, greatly larger than the dog, lives to twice its age, man enjoys an existence three times longer than the former.

1955. *The circumstances which regulate the term of existence in different species, exhibit so many peculiarities, corresponding to each, that it is difficult to offer any general observations on the subject*. Health is precarious, and the origin of diseases generally involved in obscurity. The condition of the organs of respiration and digestion, however, appears so intimately connected with the comfortable continuance of life, and

the attainment of old age, that existence may be said to depend on the due exercise of the functions which they perform. Whether animals have their blood aerated by means of lungs or gills, they require a regular supply of oxygen gas. But as this gas is extensively consumed in the process of combustion, putrefaction, vegetation, and respiration, there is occasionally a deficiency in particular places for the supply of animal life. But, in general, where there is a deficiency of oxygen, there is also a quantity of carbonic acid, or carburetted hydrogen present. These gases not only injure the system by occupying the place of the oxygen which is required, but exercise on many species a deleterious influence. To these circumstances may be referred the difficulty of preserving many fishes and aquatic mollusca in glass jars or small ponds; as a great deal of the oxygen in the air contained in the water, is necessarily consumed by the germination and growth of the aquatic cryptogamia, and the respiration of the infusory animalcula. In all cases, when the air of the atmosphere, or that which the water contains, is impregnated with noxious particles, many individuals of a particular species, living in the same district, suffer at the same time. The disease which is thus at first endemic or local, may, by being contagious, extend its ravages to other districts.

1956. *The endemic and epidemical diseases* which attack horses, sheep, and cows, obtain in this country the name of *murrain*, sometimes also the *distemper*. The general term, however, for the pestilential diseases with which these and other animals are infected, is Epizooty.

1957. *The ravages, which have been committed among the domestic animals, at various times, in Europe, by epizooties*, have been detailed by a variety of authors. Horses, sheep, cows, swine, poultry, fish, have all been subject to such attacks; and it has frequently happened, that the circumstances which have produced the disease in one species, have likewise exercised a similar influence over others. That these diseases arise from the deranged functions of the respiratory organs, is rendered probable by the circumstance, that numerous individuals, and even species, are affected at the same time, and this opinion is strengthened, when the rapidity with which they spread is taken into consideration.

1958. *Many diseases, which greatly contribute to shorten life, take their rise from circumstances connected with the organs of digestion.* Noxious food is frequently consumed by mistake, particularly by domesticated animals. When cows, which have been confined to the house, during the winter season, and fed with straw, are turned out to the pastures in the spring, they eat indiscriminately every plant presented to them, and frequently fall victims to their imprudence. It is otherwise with animals in a wild state, whose instincts guard them from the common noxious substances of their ordinary situation. The shortening of life, in consequence of the derangement of the digestive organs, is chiefly produced by a scarcity of food. When the supply is not sufficient to nourish the body, it becomes lean, the fat being absorbed to supply the deficiency; feebleness is speedily exhibited, the cutaneous and intestinal animals rapidly multiply, and, in conjunction, accelerate the downfall of the system.

1959. *The power of fasting, or of surviving without food, possessed by some animals, is astonishingly great.* An eagle has been known to live without food five weeks; a badger a month; a dog thirty-six days; a toad fourteen months, and a beetle three years. This power of outliving scarcity for time, is of signal use to many animals, whose food cannot be readily obtained; as is the case of beasts of prey and rapacious birds. But this faculty does not belong to such exclusively: wild pigeons have survived twelve days, an antelope twenty days, and a land tortoise eighteen months. Such fasting, however, is detrimental to the system, and can only be considered as one of those singular resources which may be employed in cases where, without it, life would speedily be extinguished. In situations where animals are deprived of their accustomed food, they frequently avoid the effects of starvation, by devouring substances to which their digestive organs are not adapted. Pigeons can be brought to feed on flesh, and hawks on bread. Sheep, when covered with snow, have been known to eat the wool off each other's backs.

1960. *The various diseases to which animals are subject, tend greatly to shorten the period of their existence.* With the methods of cure employed by different species, we are but little acquainted. Few accurate observations appear to have been made on the subject. Dogs frequently effect a cure of their sores by licking them. They eat grass to excite vomiting, and probably to cleanse their intestines from obstructions or worms, by its mechanical effects. Many land animals promote their health by bathing, others by rolling themselves in the dust. By the last operation, they probably get rid of the parasitical insects with which they are infected.

1961. *But independent of scarcity, or disease, comparatively few animals live to the ordinary term of natural death.* There is a wasteful war every where raging in the animal kingdom. Tribe is divided against tribe, and species against species, and neutrality is no where respected. Those which are preyed upon have certain means which they employ to avoid the foe; but the rapacious are likewise qualified for the pursuit. The exercise of the feelings of benevolence may induce us to confine our attention to the former, and adore that goodness which gives shelter to the defenceless, and protection to the weak, while we may be disposed to turn precipitately, from viewing the latter, lest we discover marks of cruelty, where we wished to contemplate nothing but kindness.

## CHAP. VI.

*Of the Distribution of Animals.*

1962. *The geographical distribution of each species of animal*, Dr. Fleming observes, may be represented by a circle, towards the centre of which, existence may be comfortably maintained; but as we approach the circumference, restraints multiply, and life at last becomes impracticable. Each species has a range peculiar to itself, so that the circle of different species intersect one another in every possible relation. Hitherto the geographical limits of but few species have been satisfactorily determined. These chiefly belong to the larger species of quadrupeds, as the African and Asiatic elephants, the ass and the quagga, the lion, hippopotamus, and polar bear. In the tribes of the less perfect animals, the species of which have been investigated by few, the extent of their geographical distribution has been very imperfectly determined. They appear to be limited to circumstances connected with temperature, food, situation, and foes.

1963. *The degree of heat* at the equatorial regions appears to be most favorable for the increase of living beings, and they diminish in numbers as we approach the poles. There is no latitude, however, which the perseverance of man has yet reached, where living beings have not been observed. The icy shores of the arctic regions are peopled as well as the arid plains or shaded forests of tropical climates. When, however, an inhabitant of the colder regions is transported to a warmer district, the increased temperature is painful, the functions become deranged, and disease and death ensue. The inhabitants of the warmer regions, when transported to the colder districts, experience inconvenience from the change of temperature, equally hurtful to the system, and fatal to its continuance. The polar bear appears to be accommodated to live in a region, whose mean annual temperature is below the freezing point. In those districts where the individuals of a species are most vigorous and prolific, the temperature most suitable for existence prevails. The native country for the horse is probably Arabia. There he exists in a wild state in the greatest numbers. In the Zetland Islands, where he is nearly in a state of nature, he is approaching the polar limits of his distribution. He has become a dwarf. He does not reach maturity until his fourth year, seldom continues in vigor beyond his twelfth, and the female is never pregnant above once in two years. At the line, where the energies of the horse terminate, however, the reindeer becomes a useful substitute. Its equatorial limits do not reach the shores of the Baltic.

1964. *To compensate the variations of the seasons* a variety of changes take place in the circumstances of animals. The clothing of animals, living in cold countries, is not only different from that of the animals of warm regions in its quantity; but in its arrangement. If we examine the covering of swine of warm countries, we find it consisting of bristles or hair of the same form and texture; while the same animals which live in colder districts, possess not only common bristles or strong hair, but a fine frizzled wool next the skin, over which the long hairs project. Between the swine of the south of England, and Scottish Highlands, such differences may be observed. Similar appearances present themselves among the sheep of warm and cold countries. The fleece of those of England consists entirely of wool; while the sheep of Zetland and Iceland possess a fleece, containing, besides the wool, a number of long hairs, which give to it, when on the back of the animal, the appearance of being very coarse. By means of this arrangement, in reference to the quantity of clothing, individuals of the same species can maintain life comfortably in climates which differ considerably in their average annual temperature.

1965. *The process of casting the hair* takes place at different seasons, according to the constitution of the animal with respect to heat. The mole has, in general, finished this operation before the end of May. The fleece of the sheep, when suffered to fall, is seldom cast before the end of June. In the northern islands of Scotland, where the shears are never used, the inhabitants watch the time when the fleece is ready to fall, and pull it off with their fingers. The long hairs, which likewise form a part of the covering, remain for several weeks, as they are not ripe for casting at the same time with the fine wool.

1966. *The moulting of birds* is another preparation for winter, which is analogous to the casting of the hair in quadrupeds.

1967. *The distribution of color* in the animal kingdom, appears to be connected with the latitude as correlative with temperature. In the warmer districts of the earth, the colors of man, quadrupeds, and birds, exhibit greater variety, and are deeper and brighter, than in the natives of colder countries. Among the inhabitants of the temperate and cold regions there are many species which, in reference to the color of their dress, do not appear to be influenced by the vicissitudes of the seasons. In others, a very marked difference prevails between the color of their summer and winter garb. A few

of the more obvious instances of these changes, in British species, may be here produced.

1968. *The alpine hare* is a very remarkable example. Its summer dress on the Grampian mountains is a tawney grey; but in winter it is a snowy white. The hair of the ermine is of a pale reddish brown during summer; in harvest it becomes clouded with pale yellow; and in November is of a snow-white color. There are many examples of changes in the color of the clothing in the feathered tribe. The white grouse or ptarmigan is of an ash color in summer, and fine white in winter. The black guillemot (*Uria grylle*) is of a sooty black during summer; during winter its plumage is clouded with ash colored spots on a white ground. This change of color in the dress of animals seems intended to regulate their temperature by the radiation or absorption of caloric: a black animal will give out its heat by radiation much slower than one in a white clothing.

1969. *The migration of animals* is another circumstance affecting their distribution. Quadrupeds make only partial migrations; as the stag and the roe from the mountains to the plains. The winged and finned quadrupeds migrate more extensively, as the great bat which inhabits England during summer, and spends its winters in a torpid state in Italy: and the Greenland seal, which migrates southwards to Ireland in winter.

1970. *The migrations of the feathered tribe* are the most numerous; but the same species which is migratory in one country, is in some cases stationary in another; as the linnet, which is migratory in Greenland, but stationary in Britain. Migrating birds are either summer birds of passage, which arrive in this country in spring; or winter birds of passage, which arrive in autumn and depart in spring.

1971. *The summer birds of passage* are, among water birds, the terns and gulls; among land birds, the swallow, quail, turtle dove, &c. *The winter birds of passage* chiefly belong to the tribe of water fowls. The swallow, about whose migrations so many idle stories have been propagated and believed, departs from Scotland about the end of September, and from England about the middle of October. In the latter month M. Adanson observed them on the shores of Africa after their migrations from Europe. He informs us, however, that they do not build their nests in that country, but only come to spend the winter. M. Prelong has not only confirmed the observations of Adanson, in reference to swallows, but has stated, at the same time, that the yellow and grey wag-tails visit Senegal at the beginning of winter. The former (*Motacilla flava*) is well known as one of our summer visitants. The nightingale departs from England about the beginning of October, and from the other parts of Europe about the same period. During the winter season it is found in abundance in Lower Egypt, among the thickest coverts, in different parts of the Delta. Those birds do not breed in that country, and to the inhabitants are merely winter birds of passage. They arrive in autumn and depart in spring, and at the time of migration are plentiful in the islands of the Archipelago. The quail is another of our summer guests, which has been traced in Africa. A few, indeed, brave the winters of England, and in Portugal they appear to be stationary. But in general they leave this country in autumn, and return in spring. They migrate about the same time from the eastern parts of the continent of Europe, and visit and re-visit in their migrations the shores of the Mediterranean, Sicily, and the islands of the Archipelago. While these birds perform those extensive migrations which we have here mentioned, others are contented with shorter journeys. Thus the razor-billed auk (*Alca torda*), and the puffin (*Alca arctica*), frequent the coast of Andalusia during the winter season, and return to us in the spring.

1972. *Our summer birds of passage*, thus appear to come to us from southern countries, and, after remaining during the warm season, return again to milder regions. A few of our summer visitants may winter in Spain or Portugal; but it appears that in general they migrate to Africa, that unexplored country possessing every variety of surface, and consequently great diversity of climate. It is true that we are unacquainted with the winter retreats of many of our summer birds of passage, particularly of small birds; but as these arrive and depart under similar circumstances with those whose migrations are ascertained, and as the operations which they perform during their residence with us are also similar, we have a right to conclude that they are subject to the same laws, and execute the same movements. What gives weight to this opinion, is the absence of all proof of a summer bird of passage retiring to the north during the winter season.

1973. *In proof of the accuracy of the preceding conclusion*, we may observe that it is a fact generally acknowledged, that the summer birds of passage visit the southern parts of the country a few days, or even weeks, before they make their appearance in the northern districts. Thus, the common swallow (*Hirundo rustica*), appears in Sussex about the beginning of the third week of April; while in the neighborhood of Edinburgh it is seldom seen before the first of May. The cuckoo appears in the same district about the last week of April; in Edinburgh seldom before the second week of May. The reverse of this holds true with these summer visitants at their departure. Thus dotterells (*Charadrius morinellus*) forsake the Grampians about the beginning of August, and Scotland by the end of that month; while they return to England in September, and remain there even until November. A difference of nearly a month takes place between the departure of the goatsucker (*Caprimulgus Europæus*) from Scotland and from the south of England.

1974. *The torpidity or hibernation of animals*, is evidently designed to afford protection against the cold of winter. There are several quadrupeds which become torpid, as the bat, hedgehog, marmot, hamster, dormouse, &c. The torpid animals of Britain usually retire in October, and re-appear in April. Previous to their entrance into this state of lethargy, these animals select a proper place, in general assume a particular position, and even in some cases provide a small stock of food.

1975. *All the torpid animals retire to a place of safety*, where, at a distance from their enemies, and protected as much as possible from the vicissitudes of temperatures, they may sleep out, undisturbed, the destined period of their slumbers. The bat retires to the roof of gloomy caves, or to the old chimneys of uninhabited castles. The hedgehog wraps itself up in those leaves of which it composes its nest, and remains at the bottom of the hedge, or under the covert of the furze, which screened it, during summer, from the scorching sun or the passing storm. The marmot and the hamster retire to their subterranean retreats, and when they feel the first approach of the torpid state, shut the passages to their habitations in such a manner, that it is more easy to dig up the earth any where else, than in such

parts which they have thus fortified. Having thus made choice of situations where they are protected from sudden alterations of temperature, and having assumed a position similar to that of their ordinary repose, these hibernating animals fall into a state of insensibility to external objects. In this torpid state they suffer a diminution of temperature; their respiration and circulation become languid; their irritability decreases in energy; and they suffer a loss of weight.

1776. *The abundance or scarcity of food* has a powerful influence on the geographical distribution of animals. Many species of insects are restricted in their eating to one kind of plants, or are parasitical on one species of animal. The distribution of such animals is thus dependent on their food. The same remark is generally applicable to carnivorous and phytivorous animals. But, in many species, though the restriction is absolute as to the nature of the food, it admits of a considerable range with regard to the variety or kind. Thus, though the lion is restricted to flesh, his cravings are equally satisfied with the carcase of a horse, a cow, or even of man. The hog in general feeds on roots, but it is not confined to those of one kind of plant; hence it can subsist wherever the earth is clothed with verdure.

1777. *The seasons exercise a powerful influence on animals*, directly, in reference to their temperature, and, indirectly, with regard to the production of their food. Thus, the insect that feeds on the leaves of a particular tree, can only enjoy its repast during that part of the season when this tree is in leaf. How, then, is life preserved during the remaining portion of the year? The resources are numerous. It either exists in the form of an unhatched egg, an inactive pupa, in the imago state, requiring little food, or actually becoming torpid.

1778. *The birds which feed on insects in summer*, in this climate, are, from the absence of this kind of sustenance in winter, obliged to have recourse to various kinds of vegetable food during that season. Should this change of diet be unsuitable, migration to other districts, where a proper supply can be obtained, becomes indispensably requisite. In compliance with these regulations, we observe numerous mammalia, birds, and fishes, accompany the shoals of herrings in their journeys; and the grampus and seal enter the mouths of rivers in pursuit of the salmon. The bats, which feed on insects in summer, could not in this country obtain a suitable supply of food. Yet the race is preserved, since the fall of temperature, which is destructive to insect life, brings on the winter torpor. With many quadrupeds, however, and even insects, especially the bee, where migration to more fertile districts is impracticable, and where torpidity is not congenial to the constitution, there is an instinctive disposition to be provident of futurity. Of quadrupeds which possess this disposition, the beaver and the squirrel may be considered as among the most remarkable.

1779. *The influence of situation on the distribution of animals*, is considerable. Some animals reside wholly in water; others are amphibious. Among terrestrial animals, there are many which execute all the operations of life in one particular situation, influenced, however by its various conditions. Such animals are necessarily limited to those countries where such situations occur. There are others, however, which shift their situations at particular seasons, without reference either to temperature or food. The curlew, which can at all times procure a subsistence on the sea-shore, and resist or counteract the changes of the seasons, retires during the period of breeding, to the inland marshes. The heron, which is equally successful in procuring food on the shore, is destined to build its nest on trees, and consequently must betake itself to wooded districts for the purposes of incubation. Its haunts in Britain are termed heronries or heronshaws. Many terrestrial animals, especially of the insect kind, pass the first period of their existence in the water. The old animals in consequence seek after that element in which to deposit their eggs, however independent they may be of its presence for their ordinary personal wants.

1780. *The rapacity of some animals* considerably affects the distribution and extension of others. Of all the foes of the animal tribe none is so powerful as man. Against many species, hostile to his interests, he carries on a war of extermination. Others he pursues for pleasure, or for the necessities or luxuries of life which they yield. In these conquests, the superiority of his mental powers is conspicuously displayed, and his claim to dominion established. Unable to contend with many species in physical strength, he has devised the pit-fall and the snare, — the lance, the arrow, and fire arms. Aided by these, every animal on the globe must yield to his attempts to capture. The lion, the elephant, and the whale, fall the victims of his skill, as well as the mouse or the sparrow. Since the use of gunpowder, indeed, the contest is so unequal, that it is in the power of man to control the limits of almost every species whose stations are accessible. The havoc which man thus commits in the animal kingdom has occasioned the extirpation of many species from those countries of which they were formerly the natural possessors. In this island, since the Roman invasion, some species of quadrupeds and birds have disappeared; and others are becoming every year less numerous. Of those which have been extirpated, the bear and the beaver, the crane and the capercaillie, may be quoted as well known examples. The same changes are taking place in every cultivated region of the earth, each having within the very limited period of history or tradition, lost many of the original inhabitants.

1781. *An acquaintance with the laws which regulate the geographical distribution of animals is indispensably necessary in our attempts to naturalise exotic species.* The temperature most suited to their health, — the food most congenial to their taste, and best fitted to their digestive organs, — the situation to which their locomotive powers are best adapted, — and the foes against which it is most necessary to

guard them, are circumstances on which we ought to bestow the most scrupulous attention, in order to insure success. There are many animals which can call forth but few counteracting energies, and, consequently, cease to thrive, upon the slightest alteration taking place in their physical condition. With others, the case is very different, and these we can easily naturalise. They can accommodate themselves to a variety of new conditions, and successfully resist the destructive tendency of the changes to which we subject them.

1982. *The change in the condition of the animals we wish to naturalise, should, in all cases, be brought about as slowly as circumstances may permit.* In this manner, the first counteracting effects of the system grow into organic habits, before all the evils of the situation are experienced, in which they are destined ultimately to reside. In this gradual manner, man has become fitted to reside in every climate, as well as many of the animals which he has reclaimed.

1983. *The total number of species of animals hitherto described exceeds fifty thousand; but of these, upwards of forty thousand are insects or reptiles.*

1984. *The British Fauna, or number of species of animals, native or naturalised in Great Britain, might be arranged as residents, periodical visitants, irregular visitants extirpated, extinct and naturalised animals.* But, as Dr. Fleming has observed, British zoologists have paid little or no attention to the geographical distribution of the native animals. Species which really live in the country are associated with such as visit it periodically, and with those which have been extirpated, have become extinct, or have been naturalised. The consequence is, that it is difficult to form a correct view of either the number or characters of our native animals.

---

## CHAP. VII.

### *Of the Economical Uses of Animals.*

1985. *On the importance of animals in the arts as laborers, as furnishing food, clothing, medicine, and materials for various manufactures, it is needless to enlarge.*

1986. *As laborers the quadrupeds are almost solely employed; and of these the most universally useful is the horse, and next the ox and the ass.* Without the constant use of these animals, the general economy of civilised life in the temperate climates, and more or less in every climate, would be entirely altered; as would be the economy of Arabia, and many parts of Africa without the use of the camel. The dog is valuable as a messenger and watching animal, and has been and is employed in that capacity in all ages and countries.

1987. *As articles of food man employs animals belonging to every class, from the quadruped to the zoophyte.* In some cases, he makes choice of a part only of an animal, in other cases, he devours the whole. He kills and dresses some animals, while he swallows others in a live state. The taste of man exhibits still more remarkable differences of a rational kind. The animals which are eagerly sought after by one tribe, are neglected or despised by another. Even those which are prized by the same tribe in one age, are rejected by their descendants in another. Thus the seals and porpoises, which, a few centuries ago, were eaten in Britain, and were presented at the feasts of kings, are now rejected by the poorest of the people.

1988. *Those quadrupeds and birds which feed on grass or grain, are generally preferred by man to those which subsist on flesh or fish.* Even in the same animal, the flesh is not always of the same color and flavor, when compelled to subsist on different kinds of food. The feeding of black cattle with barley straw, has always the effect of giving to their fat a yellow color. Ducks fed on grain have flesh very different in flavor from those which feed on fish. The particular odor of the fat of some animals seems to pass into the system unchanged, and, by its presence, furnishes us with an indication of the food which has been used.

1989. *While many kinds of animals are rejected as useless, there are others which are carefully avoided as poisonous.* Among quadrupeds and birds, none of these are to be found, while, among fishes and mollusca, several species are to be met with, some of which are always deleterious to the human constitution, while others are hurtful only at particular seasons.

1990. *The use of skins as articles of dress, is nearly coeval with our race.* With the progress of civilisation, the fur itself is used, or the feathers, after having been subjected to a variety of tedious and frequently complicated processes. Besides the hair of quadrupeds, and the feathers of birds used as clothing, a variety of products of the animal kingdom, as bone, shells, pearls, and corals, are employed as ornaments of dress, in all countries, however different in their degree of civilisation.

1991. *Medicine.* The more efficient products of the mineral kingdom have in the progress of the medical art in a great measure superseded the milder remedies furnished by animals and vegetables. The blister-fly, however, still remains without a rival; and the leech is often resorted to, when the lancet can be of no avail.

1992. *The arts.* The increase of the wants of civilised life calls for fresh exertions to supply them, and the animal kingdom still continues to furnish a copious source of materials for the arts. Each class presents its own peculiar offering, and the stores which yet remain to be investigated, appear inexhaustible.

## CHAP. VIII.

*Principles of improving the Domestic Animals used in Agriculture.*

1993. *The animals in use in British agriculture* are few, and chiefly the horse, ox, sheep, swine, and domestic fowls. The first is used solely as a laboring animal, and the rest chiefly as furnishing food. In applying the general principles of physiology to these animals with a view to their improvement for the use of man, we shall consider in succession the principles of breeding, rearing, and feeding.

SECT. I. *Of improving the Breed of Animals.*

1994. By *improvement of a breed* is to be understood the producing such an alteration in shape or description, as shall render the animal better fitted for the labors he has to perform; better fitted for becoming fat; or for producing milk, wool, eggs, feathers, or particular qualities of these. The fundamental principle of this amelioration is the proper selection of parents. Two theories have obtained notice on this subject, the one in favor of breeding from individuals of the same parentage, called the *in-and-in* system, and the other in favor of breeding from individuals of two different offsprings, called the system of *cross breeding*. As is usual in such cases, neither theory is exclusively correct, at least as far as respects agricultural improvement; for, as will afterwards appear, the principles on which a selection for breeding so as to improve the carcase of the animal depends, will lead occasionally to either mode.

1995. That *the breed of animals is improved by the largest males*, is a very general opinion; but this opinion is the reverse of the truth, and has done considerable mischief. The great object of breeding, by whatever mode, is the improvement of form, and experience has proved that crossing has only succeeded in an eminent degree, in those instances in which the females were larger than in the usual proportion of females to males; and that it has generally failed where the males were disproportionately large. (*Culley's Introduction, &c.*) The following epitome of the science of breeding, is by the late eminent surgeon, Henry Cline, who practised it extensively on his own farm at Southgate.

1996. *The external form* of domestic animals has been much studied, and the proportions are well ascertained. But the external form is an indication only of internal structure. The principles of improving it must, therefore, be founded on a knowledge of the structure and use of internal parts.

1997. *The lungs* are of the first importance. It is on their size and soundness that the strength and health of animals principally depends. The power of converting food into nourishment, is in proportion to their size. An animal with large lungs is capable of converting a given quantity of food into more nourishment than one with smaller lungs; and therefore has a greater aptitude to fatten.

1998. *The chest*, according to its external form and size, indicates the size of the lungs. The form of the chest should approach to the figure of a cone, having its apex situated between the shoulders, and its base towards the loins. Its capacity depends on its form more than on the extent of its circumference; for where the girth is equal in two animals, one may have much larger lungs than the other. A circle contains more than an ellipsis of equal circumference; and in proportion as the ellipsis deviates from the circle it contains less. A deep chest, therefore, is not capacious; unless it is proportionably broad.

1999. *The pelvis* is the cavity formed by the junction of the haunch bones with the bone of the rump. It is essential that this cavity should be large in the female, that she may be enabled to bring forth her young with less difficulty. When this cavity is small, the life of the mother and her offspring is endangered. The size of the pelvis is chiefly indicated by the width of the hips, and the breadth of the waist, which is the space between the thighs. The breadth of the loins is always in proportion to that of the chest and pelvis.

2000. *The head* should be small, by which the birth is facilitated. Its smallness affords other advantages, and generally indicates that the animal is of a good breed. Horns are useless to domestic animals, and they are often a cause of accidents. It is not difficult to breed animals without them. The breeders of horned cattle and horned sheep, sustain a loss more extensive than they may conceive; for it is not the horns alone, but also much bone in the skulls of such animals to support their horns, for which the butcher pays nothing; and besides this there is an additional quantity of ligament and muscle in the neck, which is of small value. The skull of a ram with its horns, weighed five times more than a skull which was hornless. Both these skulls were taken from sheep of the same age, each being four years old. The great difference in weight depended chiefly on the horns, for the lower jaws were nearly equal; one weighing seven ounces, and the other six ounces and three quarters, which proves that the natural size of the head was the same in both, independent of the horns and the thickness of bone which supports them. In horned animals the skull is extremely thick. In a hornless animal it is much thinner, especially in that part where the horns usually grow. To those who have reflected on the subject, it may appear of little consequence whether sheep and cattle have horns; but on a moderate calculation it will be found, that the loss in farming stock, and also in the diminution of animal food, is very considerable, from the productions of horns and their appendages. A mode of breeding which would prevent the production of these, would afford a considerable profit in an increase of meat, wool, and other valuable parts.

2001. *The length of the neck* should be proportioned to the height of the animal, that it may collect its food with ease.

2002. *The muscles*, and the tendons which are their appendages, should be large; by which an animal is enabled to travel with greater facility.

2003. *The bones*, when large, are commonly considered an indication of strength; but strength does not depend on the size of the bones, but on that of the muscles. Many animals with large bones are weak, their muscles being small. Animals that have been imperfectly nourished during growth, have their bones disproportionately large. If such deficiency of nourishment originated from a constitutional defect, which

is the most frequent cause, they remain weak during life. Large bones, therefore, generally indicate an imperfection in the organs of nutrition.

2004. *To obtain the most improved form*, the two modes of breeding described as the in-and-in and crossing modes, have been practised. The first mode may be the better practice, when a particular variety approaches perfection in form; especially for those who may not be acquainted with the principles on which improvement depends. When the male is much larger than the female, the offspring is generally of an imperfect form. If the female be proportionately larger than the male, the offspring is of an improved form. For instance, if a well formed large ram be put to ewes proportionately smaller, the lambs will not be so well shaped as their parents; but if a small ram be put to larger ewes, the lambs will be of an improved form. The proper method of improving the form of animals consists in selecting a well formed female, proportionately larger than the male. The improvement depends on this principle, that the power of the female to supply her offspring with nourishment, is in proportion to her size, and to the power of nourishing herself from the excellence of her constitution. The size of the fœtus is generally in proportion to that of the male parent; and therefore, when the female parent is disproportionately small, the quantity of nourishment is deficient, and her offspring has all the disproportions of a starveling. But when the female, from her size and good constitution, is more than adequate to the nourishment of a fœtus of a smaller male than herself, the growth must be proportionately greater. The larger female has also a larger quantity of milk, and her offspring is more abundantly supplied with nourishment after birth.

2005. *Abundant nourishment* is necessary to produce the most perfect formed animal, from the earliest period of its existence until its growth is complete. As already observed, the power to prepare the greatest quantity of nourishment from a given quantity of food, depends principally on the magnitude of the lungs, to which the organs of digestion are subservient. To obtain animals with large lungs, crossing is the most expeditious method; because well formed females may be selected from a variety of large size, to be put to a well formed male of a variety; that is, rather smaller. By such a mode of crossing, the lungs and heart become proportionately larger, in consequence of a peculiarity in the circulation of the fœtus, which causes a larger proportion of the blood, under such circumstances, to be distributed to the lungs than to the other parts of the body; and as the shape and size of the chest depend upon that of the lungs, hence arises that remarkably large chest, which is produced by crossing with females that are larger than the males. The practice, according to this principle of improvement, however, ought to be limited; for it may be carried to such an extent, that the bulk of the body might be so disproportioned to the size of the limbs as to prevent the animal from moving with sufficient facility. In animals, where activity is required, this practice should not be extended so far as in those which are intended for the food of man.

2006. *The characters of animals*, or the external appearances by which the varieties of the same species are distinguished, are observed in the offspring; but those of the male parent more frequently predominate. Thus in the breeding of horned animals there are many varieties of sheep, and some of cattle, which are hornless. If a hornless ram be put to horned ewes, almost all the lambs will be hornless; partaking of the character of the male more than of the female parent. In some countries, as Norfolk, Wiltshire, and Dorsetshire, most of the sheep have horns. In Norfolk the horns may be got rid of, by crossing with Ryeland rams; which would also improve the form of the chest, and the quality of wool. In Wiltshire and Dorsetshire, the same improvements might be made, by crossing the sheep with South Down rams. An offspring without horns, or rarely producing horns, might be obtained from the Devonshire cattle, by crossing with hornless bulls of the Galloway breed; which would also improve the form of the chest; in which the Devonshire cattle are often deficient.

2007. *Examples of the good effects of crossing* may be found in the improved breeds of horses and swine in England. The great improvement of the breed of horses arose from crossing with the diminutive stallions, Barbs and Arabians; and the introduction of Flanders mares into this country was the source of improvement in the breed of cart horses. The form of the swine has been greatly improved, by crossing with the small Chinese boar.

2008. *Examples of the bad effects of crossing the breed are more numerous*. When it became the fashion in London to drive large bay-horses, the farmers in Yorkshire put their mares to much larger stallions than usual, and thus did infinite mischief to their breed, by producing a race of small chested, long legged, large boned, worthless animals. A similar project was adopted in Normandy, to enlarge the breed of horses there, by the use of stallions from Holstein; and in consequence, the best breed of horses in France would have been spoiled had not the farmers discovered their mistake in time, by observing the offspring much inferior in form to that of the native stallions. Some graziers in the Isle of Sheppy conceived, that they could improve their sheep by large Lincolnshire rams; the produce of which, however, was much inferior to the shape of the carcase, and the quality of the wool; and the flocks were greatly impaired by this attempt to improve them. Attempts to improve the animals of a country by any plan of crossing, should be made with the greatest caution; for by a mistaken practice, extensively pursued, irreparable mischief may be done. In any country where a particular race of animals has continued for centuries, it may be presumed that their constitution is adapted to the food and climate.

2009. *The pliancy of the animal economy* is such, that an animal will gradually accommodate itself to great vicissitudes in climate, and alterations in food; and by degrees undergo great changes in constitution; but these changes can be effected only by degrees, and may often require a great number of successive generations for their accomplishment. It may be proper to improve the form of a native race, but at the same time it may be very injudicious to attempt to enlarge their size; for the size of animals is commonly adapted to the soil and climate which they inhabit. Where produce is nutritive and abundant, the animals are large, having grown proportionally to the quantity of food which, for generations, they have been accustomed to obtain. Where the produce is



scanty, the animals are small, being proportioned to the quantity of food which they were able to procure. Of these contrasts, the sheep of Lincolnshire and of Wales are examples. The sheep of Lincolnshire would starve on the mountains of Wales.

2010. *Crossing the breed of animals may be attended with bad effects* in various ways; and that even when adopted in the beginning on a good principle; for instance, suppose some larger ewes than those of the native breed were taken to the mountains of Wales, and put to the rams of that country, if these foreign ewes were fed in proportion to their size, their lambs would be of an improved form, and larger in size than the native animals; but the males produced by this cross, though of a good form, would be disproportionate in size to the native ewes; and, therefore, if permitted to mix with them, would be productive of a starveling, ill-formed progeny. Thus a cross, which, at first was an improvement, would, by giving occasion to a contrary cross, ultimately prejudice the breed. The general mistake in crossing has arisen from an attempt to increase the size of a native race of animals; being a fruitless effort to counteract the laws of nature.

2011. *The Arabian horses* are, in general, the most perfect in the world; which probably has arisen from great care in selection, and also from being unmixed with any variety of the same species; the males, therefore, have never been disproportioned in size to the females.

2012. *The native horses of India* are small, but well proportioned, and good of their kind. With the intention of increasing their size, the India company have adopted a plan of sending large stallions to India. If these stallions should be extensively used, a disproportioned race must be the result, and a valuable breed of horses may be irretrievably spoiled.

2013. *From theory, from practice, and from extensive observation*, the last more to be depended on than either, "it is reasonable," Cline continues, "to form this conclusion: it is wrong to enlarge a native breed of animals, for in proportion to their increase of size, they become worse in form, less hardy, and more liable to disease." (*Communications to the B. of Ag.* vol. iv. p. 446.)

2014. *The above opinions* may be considered as supported by the most eminent practical breeders, as Bakewell, Culley, Somerville, Parry, and others, and by most theorists, as Coventry, Darwin, Hunt, Young, &c. T. A. Knight writes in the *Communications to the Board of Agriculture* in favor of cross breeding, as do Pitt and others in the *County Surveys*, but mostly from very limited experience. Sir J. S. Sebright, in a letter addressed to Sir Joseph Banks, on *improving the breed of domestic animals*, 1809, has taken the opposite side of the question, but the meaning he attaches to the term breeding *in-and-in* is so limited, as to render it a very different sort of breeding from that practised by Messrs. Bakewell and Culley, which has been generally so named and recommended by Cline and others, who favor, rather than otherwise, the *in-and-in* system. He says, "Magnell's fox-hounds are quoted as an instance of the success of breeding *in-and-in*; but upon speaking to that gentleman upon the subject, I found that he did not attach the meaning that I do, to the term *in-and-in*. He said that he frequently bred from the father and the daughter, and the mother and the son. This is not what I consider as breeding *in-and-in*; for the daughter is only half of the same blood as the father, and will probably partake, in a great degree, of the properties of the mother. Magnell sometimes bred from brother and sister; this is certainly what may be called a *little close*: but should they both be very good, and, particularly, should the same defects not predominate in both, but the perfections of the one promise to correct in the produce the imperfections of the other, I do not think it objectionable: much farther than this the system of breeding from the same family, cannot, in my opinion, be pursued with safety." (p. 10.) John Hunt, surgeon at Loughborough, a friend of Bakewell and Darwin, in a reply to Sir J. S. Sebright's pamphlet, entitled *Agricultural Memoirs, &c.* 1812, justly observes, that as Sir John has given no definition of the term *in-and-in*, from what may be gathered from the above extract he seems to have been as near as possible of the same mind as Bakewell, whose practice it is on all sides allowed, was "to put together those animals which were most perfect in shape without regard to affinity in blood." This, in fact, is the general practice in all the best breeding districts, and especially in Leicestershire and Northumberland.

2015. *George Culley*, a Northumberland farmer of great practice in breeding and feeding, in his *Observations on Live Stock*, not only concurs in this principle as far as respects quadrupeds, but considers it to hold good in the feathered tribe, and, in short, in animals of every kind. His conclusion is, "That of all animals, of whatever kind, those which have the smallest, cleanest, finest bones, are in general the best proportioned, and covered with the best and finest grained meat." "I believe," he adds, "they are also the hardest, healthiest, and most inclinable to feed; able to bear the most fatigue while living, and worth the most per lb. when dead." (*Observations, &c.* 222.)

2016. *Cross breeding, under judicious management*, might probably be often employed to correct the faults of particular breeds, or to impart to them new qualities. "Were I," says Sir J. S. Sebright, "to define what is called the art of breeding, I should say, that it consisted in the selection of males and females, intended to breed together, in reference to each other's merits and defects. It is not always by putting the best male

to the best female, that the best produce will be obtained; for should they both have a tendency to the same defect, although in ever so slight a degree, it will in general preponderate so much in the produce, as to render it of little value. A breed of animals may be said to be improved, when any desired quality has been increased by art, beyond what that quality was in the same breed, in a state of nature; the swiftness of the race horse, the propensity to fatten in cattle, and the fine wool in sheep, are improvements which have been made in particular varieties of the species to which those animals belong. What has been produced by art must be produced by the same means, for the most improved breeds will soon return to a state of nature, or perhaps defects will arise, which did not exist when the breed was in its natural state, unless the greatest attention is paid to the selection of the individuals who are to breed together.

2017. *We must observe the smallest tendency to imperfection* in our stock, the moment it appears, so as to be able to counteract it, before it becomes a defect; as a rope dancer, to preserve his equilibrium, must correct the balance, before it is gone too far, and then not by such a motion, as will incline it too much to the opposite side. The breeder's success will depend entirely upon the degree in which he may happen to possess this particular talent.

2018. *Regard should not only be paid to the qualities apparent in animals* selected for breeding, but to those which have prevailed in the race from which they are descended, as they will always show themselves, sooner or later, in the progeny: it is for this reason that we should not breed from an animal, however excellent, unless we can ascertain it to be what is called *well bred*; that is, descended from a race of ancestors, who have, through several generations, possessed in a high degree the properties which it is our object to obtain. The offspring of some animals is very unlike themselves; it is, therefore, a good precaution, to try the young males with a few females, the quality of whose produce has been already ascertained; by this means we shall know the sort of stock they get, and the description of females to which they are the best adapted. If a breed cannot be improved, or even continued in the degree of perfection at which it has already arrived, but by breeding from individuals so selected as to correct each other's defects, and by a judicious combination of their different properties (a position that will not be denied), it follows that animals must degenerate, by being long bred from the same family, without the intermixture of any other blood, or from being what is technically called, *bred in-and-in*."

2019. *Bakewell and Culley* say, "like begets like," therefore breed from the best. Of this, says Sir J. S. Sebright, there can be no doubt "but it is to be proved how long the same family, *bred in-and-in*, will continue to be the best." Cross breeding appears no doubt more consonant to what takes place in nature than breeding from very near relationship; and arguing from analogy, the result of certain experiments made by T. A. Knight, on the vegetable kingdom, seems to justify us in concluding that occasional crossing may become not only advantageous, but even necessary for the purpose of correcting defects. Nevertheless, as the last mentioned writer and Cline observe, it can only be safely resorted to by skilful and experienced breeders.

## SECT. II. *Of the general Principles of rearing, managing, and feeding domestic Animals.*

2020. *Immediately after the birth of every animal*, even of such as are domesticated, the rudiments of its education, as well as its bodily nourishment, are necessarily given by the mother. For this purpose the latter should, during her pregnancy, have been daily protected against all extremes of temperature, well provided with shade and shelter, and abundantly supplied with food and water. When the period of gestation arrives, she should, in general, also be separated from the rest of the flock or herd, and by whatever means the case may demand, kept comfortable and tranquil.

2021. *After the birth*, the first interference on the part of man should be that of supplying the mother with food of a light and delicate quality, compared to that which she had been in the habit of using, and also of administering the same description of food to the offspring, so far as it may by its nature be able to use it. The gentlest treatment should accompany these operations; and the opportunity taken of familiarizing both parent and offspring with man, by gently caressing them, or at least, by familiar treatment on the part of the attendant.

2022. *As the animals increase in size and strength*, they should have abundance of air, exercise, and food, according to their natures; and whatever is attempted by man in the way of taming or teaching should be conducted on mild and conciliating principles, rather than on those of harshness and compulsion. Caresses, or familiar treatment, should generally be accompanied by small supplies of food, at least at first, as an inducement to render the animal submissive to them; afterwards habit will, even in the inferior creation, render the familiarities of man agreeable to them for their own sake; but even then, to keep up this feeling, small portions of select food should frequently be employed as a reward. By contrasting this method with that of taming or teaching animals by fear or compulsion, the advantages of the former mode will be evident.

2023. *Interest is the grand mover of animals, as well as of man.* In taming by fear, all the interest which the animal has is the avoiding an evil; in taming by caresses and food, it is the attainment of enjoyment. The most extraordinary results are recorded as having been obtained by the mild mode with almost every species of animal on which it has been tried: to this may be advantageously joined, in the more powerful animals, hunger and fatigue. "The breeder Bakewell, surgeon Hunt informs us, at an advanced period of life, not only conquered a vicious restive horse, but, without the assistance of either grooms or jockies, taught this horse to obey his verbal orders with as great attention as the most accomplished animal that was ever educated at Astley's school. Bakewell was accustomed to say, that his horse could do every thing but speak. The method which he took to conquer this vicious animal was never told, even to his own domestics. He ordered his own saddle and bridle to be put on this horse, which at that time was thought to be ungovernable, when he was prepared for a journey of two or three hundred miles; and, that no one might be witness to the contest, he led the horse till he was beyond the reach of observation; how far he walked, or in what manner this great business was accomplished, was never known; but, when he returned from his journey, the horse was as gentle as a lamb, and would obey his master's verbal orders on all occasions. When what are called irrational animals are taught such strict obedience to the command of a superior order, it is in general supposed to be the effect of fear; but Bakewell never made use of either whip or spur. When on horseback he had a strong walking-stick in his hand, which he made the most use of when on foot; he always rode with a slack rein, which he frequently let lie upon the horse's neck, and so great was his objection to spurs, that he never wore them. It was his opinion that all such animals might be conquered by gentle means; and such was his knowledge of animal nature, that he seldom failed in his opinion, whether his attention was directed to the body or the mind." (*Agri. Mem.* p. 127.)

2024. *The purposes for which animals are fed or nourished,* are for promoting their enlargement or growth; for fitting them for labor; for the increase of certain animal products; or for fattening them for slaughter as human food. We shall confine our remarks to the last purpose as being the most important, and as necessarily including much of what belongs to the three others. In doing this, the following points require to be attended to: abundance of proper food, a proper degree of heat, and protection against extremes of weather; good air, water, moderate exercise, tranquillity, cleanliness, comfort, and health.

2025. *Food,* though it must be supplied in abundance, ought not to be given to satiety. Intervals of resting and exercise must be allowed according to circumstances. Even animals grazing on a rich pasture have been found to feed faster when removed from it once a day, and either folded or put in an inferior pasture for two or three hours. Stall-fed cattle and swine will have their flesh improved in flavor by being turned out into a yard or field once a day; and many find that they feed better, and produce better flavored meat when kept loose under warm sheds or hammels, one or two in a division, a practice now very general in Berwickshire. (See *Hammel.*) Coarser food may be first given to feeding animals; and as they acquire flesh, that which is of more solid and substantial quality. In general it may be observed, that if the digestive powers of the animal are in a sound state, the more food he eats, the sooner will the desired result be obtained; a very moderate quantity beyond sufficiency constitutes abundance; but by withholding this additional quantity, an animal, especially if young, may go on eating for several years, without ever attaining to fatness. Properly treated, a well fed ox, of moderate size, will feed on a rich pasture in from four to six months, and in stalls or covered pens, with green or steamed food in a shorter period.

2026. *In young growing animals,* the powers of digestion are so great, that they require less rich food than such as are of mature age; for the same reason also they require more exercise. If rich food is supplied in liberal quantities, and exercise withheld, diseases are generated, the first of which may be excessive fatness; growth is impeded by very rich food, for experience shows, that the coarsest fed animals have uniformly the largest bones. Common sense will suggest the propriety of preferring a medium course between very rich and very poor nutriment.

2027. *Mastication and cooking.* Unless food be thoroughly deprived of its vegetative powers before it enters the stomach, the whole nourishment which it is capable of affording cannot be derived from it. In the case of the leaves and stalks of vegetables, this is in general effected by mastication; but it requires some care to accomplish it in the case of grains. Hence the advantage of mixing corn given to horses or cattle with chaff or chopped straw; and hence, it is supposed by some, the intention of nature, in the instinct which fowls have to swallow small stones, is intended for the same object. But the most effectual mode of destroying the living principle, is by the application of heat; and if vegetable food of every kind could be steamed or boiled before it was given to animals (at least in winter, and for fattening to slaughter, or feeding for edible products), it is rendered probable by analogy and experiment, that much more nourishment would be derived from it.

2028. *Salt,* it appears, from various experiments, may be advantageously given to most animals, in very small quantities; it acts as a whet to the appetite, promotes the secretion of bile, and, in general, is favorable to health and activity. In this way only can it be considered as preventing or curing diseases; unless perhaps in the case of worms, to which all saline and bitter substances are known to be injurious.

2029. *That degree of heat* which is aborigine, or has by habit, and the breeding from successive generations in a cold climate, become natural to animals, is necessary to their

well being; and a somewhat increased degree in the cold months, or diminished degree in such as are oppressively warm, is advantageous in the fattening process. Where a sufficient degree of warmth to promote the ordinary circulation of the blood is not produced by the natural climate, or by exercise, it must be supplied by an artificial climate. Houses and sheds are the obvious resources both for this purpose, and for protection from *extremes of weather*. Cold rains and northerly winds are highly injurious, by depriving the external surface of the body of caloric more rapidly than it can be supplied from within by respiration, and the action of the stomach; and also by contracting the pores of the skin, so as to impede circulation. When an animal happens to shed its covering, whether of hair, wool, or feathers, at such inclement seasons, the effects on its general health are highly injurious. The excessive heats of summer, by expanding all the parts of the animal frame, occasions a degree of lassitude, and want of energy even in the stomach and intestines; and while the animal eats and digests less food than usual, a greater waste than usual takes place by perspiration. Nature has provided trees, rocks, caverns, hills and waters, to moderate these extremes of heat and weather, and man imitates them by hovels, sheds, and other buildings, according to particular circumstances.

2030. *Good air and water* it may seem unnecessary to insist on; but cattle and horses, and even poultry pent up in close buildings, where there are no facilities for a change of the atmosphere, often suffer on this account. A slight degree of fever is produced at first, and after a time, when the habit of the animal becomes reconciled to such a state, a retarded circulation, and general decay or diminution of the vital energies takes place.

2031. *Water ought to be soft and pure*, as being a better solvent than such as is *hard* and charged with earthy particles. It ought to be of a moderate temperature, under that of the open air in hot weather, and exceeding it in winter. Deep wells afford this difference. In particular cases, as in those animals in a suckling state, or milked by man, warmed water has been found advantageous. Meals, or other light rich matters, are sometimes mixed with it; but it does not clearly appear, excepting in the last case, that liquid food is so generally advantageous for fattening animals, as that which being equally rich is solid. Some judgment is requisite as to the time most proper for giving water to animals. In general, it does not appear necessary to supply it immediately after eating, for animals in a natural state, or pasturing in a field, generally lie down after filling themselves, and after the process of digestion seems to have gone on some time, they go in quest of water. Perhaps the immediate dilution of food, after being taken into the stomach with water, may, at the same time, weaken the digestive powers, by diluting the gastric juice. At all events the free use of water at any time, but especially during meals, is found to weaken digestion in the human species. As animals of every kind become reconciled to any habit, not ultimately injurious to health, perhaps for housed animals a stated quantity of water, given an hour, or an hour and a half after what may be called their meals, may be the best mode.

2032. *Moderate exercise* ought not to be dispensed with, where the flavor of animal produce is any object; it is known to promote circulation, perspiration, and digestion, and by consequence to invigorate the appetite. Care must be taken, however, not to carry exercise to that point where it becomes a labor instead of a recreation. In some cases, as in feeding swine and poultry, fatness is hastened by promoting sleep and preventing motion, rather than encouraging it; but such animals cannot be considered healthy fed; in fact their fatness is most commonly the result of disease.

2033. *Tranquillity* is an obvious requisite, for where the passions of brutes are called into action, by whatever means, their influence on their bodies is often as great as in the human species. Hence the use of castration, complete or partial separation, shading from too much light, protection from insects, dogs, and other annoying animals, and from the too frequent intrusion of man.

2034. *Cleanliness* is favorable to health, by promoting perspiration and circulation. Animals in a wild state attend to this part of their economy themselves; but in proportion as they are cultivated, or brought under the control of man, this becomes out of their power; and to ensure their subserviency to his wishes, man must supply by art this as well as other parts of culture. Combing and brushing stall-fed cattle and cows is known to contribute materially to health; though washing sheep with a view to cleaning the wool often has a contrary effect from the length of time the wool requires to dry. This often brings on colds, and aggravates the liver complaint, so incident to these animals. Bathing or steeping the feet of stalled animals occasionally in warm water would no doubt contribute to their health; bathing swine two or three times a week in hot water, as in that used for boiling or steaming food, has been found a real advantage.

2035. *Comfort*. An animal may be well fed, lodged, and cleaned, without being comfortable in every respect; and in brutes, as well as men, want of comfort operates on the digestive powers. If the surface of a stall in which an ox, or a horse stands, deviates much from a level, he will be continually uneasy; and he will be uneasy during night, if its surface is rough, or if a proper bed of litter is not prepared every evening for it to repose on. The form of racks and mangers is often less commodious than it might be. A hay rack which projects forward is bad; because the animal in drawing out the hay is teased with the hay seeds falling in its eyes or ears; and this form, it may be added, is apt to cause the breath of the animal to ascend through its food, which

must after a time render it nauseous. For this reason hay should lie as short a time as possible in lofts, but when practicable be given direct from the rick. Poultry of different kinds are often crowded together without any regard to the comfort of the particular kinds by attending to their peculiarities, such as the web feet of the duck tribe, the proper size of roosting sticks for the toed feet of the other tribes. Even the crowing of the cock must cause some degree of irritation, and consequently impede health and fattening by disturbing the repose of quiet fowls, such as the turkey or goose. Various other instances will occur to a reflecting mind; and surely it must be a duty as agreeable as it is conducive to our own interest to promote as much as possible the comfort of those animals whose lives are shortly to be sacrificed for ours.

2036. *Health.* A good state of health will, in general, be the result of the mode of feeding and treatment which we have described; but in proportion as our treatment, either of ourselves or other animals, is refined and artificial, in the same proportion are the functions of nature liable to derangement or interruption from atmospherical changes, and various accidental causes. When this takes place recourse must be had to art for relief. This is an obvious, natural, and reasonable practice; though some contend that as every disease is only an effort of nature to relieve the being from some evil, it ought to be left to itself. To treat animals when in health artificially, and the moment when they become diseased to abandon them to nature, is a proposition so incongruous and absurd, that one would suppose it would be rejected by the common sense of mankind. There are, however, some solitary instances of medical men having adopted this opinion; but the melancholy result of their acting on it in the human species, as well as its utter rejection by all rational professors, and men in general, has reduced it to its intrinsic value. There may be much of quackery in medicine; and unquestionably there is a great deal in the art as applied to the brute creation by common practitioners; but to reject the medical art altogether, becomes on the other hand a species of quackery just as despicable as the other, and not less dangerous; for it cannot be much better for a patient to be left to die through neglect, than to be killed by over-much care.

2037. *Ferriery, as applied to cattle and sheep,* is a department of medicine in which perhaps greater ignorance prevails than in any other. The subject as applied to horses has, since the establishment of veterinary schools in this country, and in France, become better understood; but the pupils from these establishments are so thinly scattered, that as Laurence (veterinary surgeon, and author of a *Treatise on Horses*) observes, it were desirable that country surgeons should in their different localities give instructions to the empirical local practitioners in the country, and to intelligent bailiffs; and that gentlemen of property might have such a sense of their own interest as to call in a surgeon in all cases of the least difficulty. All that we can here do is to repeat our advice of studying the art of prevention rather than of cure; to suggest that, in general, an analogy subsists between the constitution and diseases of the human and brute creation; to avoid recipes and specific cures, rarely to bleed animals, unless by regular advice; and to confine as much as possible the operations of cow doctors and smiths to giving warm drinks, gentle purges, and glisters, which can seldom do any harm. Proprietors who can afford to employ intelligent bailiffs, or rather who give such men considerable salaries, should ascertain previously to hiring them, by means of general questions, or by reference to a professor, whether they know any thing of the subject. By thus creating a demand for this species of knowledge, it would soon be produced in abundance.

### SECT. III. Of Feeding for Extraordinary Purposes.

2038. *The extraordinary purposes of feeding* may comprehend, promoting the growth, nativity, or obesity of particular parts of the body; promoting the produce of milk or eggs; or, for fitting an animal for hard labor or long journeys, fasting, and other privations.

2039. *Feeding for extraordinary purposes,* such as promoting the growth of the liver in geese; the heart in turkeys; producing excessively fat poultry, &c. seems to us utterly unjustifiable on principles of humanity, and unworthy of enlightened men. The practice of pulling out the animal's eyes, nailing them to the spot, and cramming or forcing the food down their throats, is surely as repugnant to good taste and feeling, as the food so produced must be tasteless and unwholesome. Putting out the eyes of certain singing birds to improve their voice; and some practices in the rearing of game cocks, and fancy pigeons, (at least the two first) seem equally reprehensible.

2040. *The fattening of fowls for the London market* is a considerable branch of rural economy in some convenient situations. "They are put up in a dark place, and crammed with a paste made of barley meal, mutton suet, and some treacle or coarse sugar, mixed with milk, and are found to be completely ripe in a fortnight. If kept longer, the fever that is induced by this continued state of repletion renders them red and unsaleable, and frequently kills them." (*Agricultural Report of Berkshire, by William Mavor, L.L.D.* 8vo. London, 1813.) But fowls brought to this state of artificial obesity are never so well flavored in

the flesh, and probably not so salubrious as those of the same species, fattened in a more natural way. The great secret of having fine pullets is cleanliness, and high keeping with the best corn.

2041. *The process followed in different parts of France to enlarge the liver, is described at length by Sonnini (Nouveau Dictionnaire d'Histoire Naturelle, art. Oie.); "The object is to cause the whole vital forces to be determined towards this part of the animal, by giving it a kind of hepatic cachexy. In Alsace, the individual buys a lean goose, which he shuts up in a small box, so tight that it cannot turn in it. The bottom is furnished with a wide grating of rods, for the passage of the dung. In the fore part there is a hole for the head, and below it a small trough is kept always full of water, in which some pieces of wood charcoal are left to steep. A bushel of maize is sufficient to feed it during a month, at the end of which time the goose is sufficiently fattened. A thirtieth part is soaked in water each night, and crammed down its throat next day, morning and evening. The rest of the time it drinks and guzzles in the water. Towards the 22d day, they mix with the maize some poppy oil, and, at the end of the month, it is known by a lump of fat under each wing, or rather by the difficulty of breathing, that it is time to kill it, otherwise it will die of fat. The liver is then found weighing one or two pounds, and, besides, the animal is excellent for the table, and furnishes, during its roasting, from three to five pounds of fat, which is used in the cooking of vegetables. Of six geese, there are commonly only four (and these are the youngest) which answer the expectation of the fatterer. They are kept in a cellar, or place with little light.*

2042. *The Roman epicures, who prized the livers of geese, had already observed, that darkness was favorable to this kind of education, no doubt, because it prevents all distraction, and directs the whole powers towards the digestive organs. The want of motion, and the difficulty of respiration, may be also taken into consideration; the first by diminishing the waste of the system, and both by retarding the circulation in the vena portarum, of which the blood ought to become hydrogenated, in proportion as its carbon unites itself to the oxygen, which that liquid absorbs. This favors the formation of the oily juice, which, after having filled the cellular system of the body, enters into the biliary system and substance of the liver, and gives it that fatness and size which is so delightful to the palates of true gourmands. The liver thus only becomes enlarged consecutively, and the difficulty of respiration does not appear till the end, when its size prevents the action of the diaphragm. The leanness of geese subjected to this treatment is often mentioned; but it can only occur in those whose eyes are put out, and feet nailed down to a board, as the consequence of this barbarous treatment. Among a hundred fatteners, there are scarcely two who adopt this practice, and even these do not put out their eyes till a day or two before they are killed. And, therefore, the geese of Alsace, which are free from these cruel operations, acquire a prodigious fatness, which may be called an oleaginous dropsy, the effect of a general atony of the absorbents, caused by want of exercise, combined with succulent food, crammed down their throats, and in an under oxygenated atmosphere." (Encyc. Brit. Sup. art. Food.)*

2043. *Early lamb.* As an instance of both breeding and feeding for extraordinary purposes, we may mention the practice of those farmers who furnish the tables of the wealthy with lamb, at almost every season of the year, by selecting certain breeds of sheep, such as the Dorsetshire, which lamb very early, or by treating them in such a way as to cause the female to come in heat at an unnatural time. In this way, lamb is procured as an article of luxury, as early as November and December; and, on the contrary, by keeping the ewe on a cold and poor hilly pasture, the lambing season is retarded, and lamb furnished in September and October.

2044. *Feeding for promoting the produce of milk or eggs.* That which in plants or animals is produced for particular purposes in nature, may, by certain modes of treatment, be rendered, for a time, a habit in the plant or animal, without reference to its natural end. Thus in many cases annual plants may be rendered perennial by continually pinching off their flowers as they appear; and animals which give milk or lay eggs, may be made to produce both for a much longer time than is natural to them, by creating a demand in their constitutions for these articles by frequent and regular milkings, and by taking away every egg as soon as produced; and then furnishing the constitution with the means of supplying this demand by appropriate food,—by rich liquid food, in the case of milking animals—, and by dry, stimulating, and nourishing food, in the case of poultry.

2045. *Feeding to fit animals for hard labor, or long journeys.* It seems agreed on, that dry rich food is the best for this purpose; and that very much depends on rubbing, cleaning, and warmth, in the intervals between labor and rest, in order to maintain something of the increased circulation; and, in short, to lessen the influence of the transition from the one to the other. The quantity of water given should never be considerable; at least in cold countries and seasons. (See *Horse*.)

SECT. IV. *Of the Modes of killing Animals.*

2046. *The mode of killing animals has considerable effect on the flesh of the animal.* Most of those slaughtered for food are either bled to death or are bled profusely immediately after being deprived of life in some other way. The common mode of killing cattle in this kingdom is, by striking them on the forehead with a pole-axe, and then cutting their throats to bleed them. But this method is cruel and not free from danger. The animal is not always brought down by the first blow, and the repetition is difficult and uncertain, and if the animal be not very well secured, accidents may happen. Lord Somerville (*General Survey of the Agriculture of Shropshire, by Joseph Plymley, M. A.* 8vo. London, 1803, p. 243.), therefore, endeavored to introduce the method of pithing or laying cattle, by dividing the spinal marrow above the origin of the phrenic nerves, as is commonly practised in Barbary, Spain, Portugal, Jamaica, and in some parts of England; and Jackson says, that the "best method of killing a bullock, is by thrusting a sharp-pointed knife into the spinal marrow, when the bullock will immediately fall without any struggle, then cut the arteries about the heart." (*Reflections on the Commerce of the Mediterranean, by John Jackson, Esq. F.S.A.* 8vo. London, 1804, p. 91.) Although the operation of pithing is not so difficult but it may, with some practice, be performed with tolerable certainty; and although Lord Somerville took a man with him to Portugal to be instructed in the method, and made it a condition that the prize cattle at his exhibitions should be pithed instead of being knocked down, still pithing is not becoming general in Britain. This may be partly owing to prejudice; but we have been told that the flesh of the cattle killed in this way in Portugal is very dark, and becomes soon putrid, probably from the animal not bleeding well, in consequence of the action of the heart being interrupted before the vessels of the neck are divided. It therefore seems preferable to bleed the animal to death directly, as is practised by the Jew butchers.

2047. *Du Gard's observations on pithing, deserve attention.* This gentleman, a surgeon of the Shrewsbury Infirmary, after mature consideration, is against the practice, as causing more pain than it is intended to avoid. He says, "Pain and action are so generally joined, that we measure the degree of pain by the loudness of the cries, and violence of the consequent exertion; and therefore conclude, on seeing two animals killed, that the one which makes scarcely a struggle, though it may continue to breathe, suffers less than that which is more violently convulsed, and struggles till life is exhausted. It appears, however, that there may be acute pain without exertion, perhaps as certainly as there is action without pain; even distortions that at the first glance would seem to proceed from pain, are not always really accompanied with sensation. To constitute pain there must be a communication between the injured organ and the brain."

2048. *In the old method of slaughtering, a concussion of the brain takes place, and therefore the power of feeling is destroyed.* The animal drops, and although convulsions take place generally longer and more violent than when the spinal marrow is divided, yet there is, I think, reason to believe that the animal suffers less pain. The immediate consequence of the blow is the dilatation of the pupil of the eye, without any expression of consciousness or fear on the approach of the hand.

2049. From all these circumstances, Du Gard concludes that *the new method of slaughtering cattle is more painful than the old.* The puncture of the medulla spinalis does not destroy feeling, though it renders the body quiescent, and in this state the animal both endures pain at the punctured part, and suffers, as it were, a second death, from the pain and faintness from loss of blood in cutting the throat, which is practised in both methods. Everard Home, in a valuable paper (*Shrew. Rep.* p. 250.) has suggested a mode of performing the operation, which would answer completely, could we be sure of having operators sufficiently skillful; but we may the less regret the difficulty of getting new modes established when we thus see the superiority of an old custom under very improbable circumstances; and if well meant reformers wanted any additional motives to care and circumspection, a very forcible one is furnished in the instance of the time and trouble taken to introduce this operation, and which, as it has been hitherto practised, is the very reverse of what was intended.

2050. *Jewish modes.* The Mosaic law so strictly prohibits the eating of blood, that the Talmud contains a body of regulations concerning the killing of animals; and the Jews, as a point of religion, will not eat the flesh of any animal not killed by a butcher of their own persuasion. Their method is to tie all the four feet of the animal together, bring it to the ground, and, turning its head back, to cut the throat at once down to the bone, with a long, very sharp, but not pointed knife, dividing all the large vessels of the neck. In this way the blood is discharged quickly and completely. The effect is indeed said to be so obvious, that some Christians will eat no meat but what has been killed by a Jew butcher. Calves, pigs, sheep, and lambs, are all killed by dividing at once the large vessels of the neck.

2051. *Animals which are killed by accident, as by being drowned, hanged, or frozen, or by a fall, or ravenous animal, are not absolutely unwholesome.* Indeed, they only differ from those killed methodically in not being bled, which is also the case with animals that are snared, and in those killed by hounds. Animals which die a natural death should never be eaten, as those are undeniable instances of disease, and even death being the consequence.

2052. *Animals frequently undergo some preparation before they are killed.* They are

commonly kept without food for some time, as if killed with full stomachs their flesh is considered not to keep well. Oxen are commonly fasted two or three days, smaller animals a day, but it is evident that the practice must not be carried too far, as the opposite effect will be produced by the animal falling off or getting feverish. Dr. Lister has stated that nothing contributes more to the whiteness and tenderness of the flesh of calves than often bleeding them, by which the coloring matter of the blood is exhausted, and nothing but colorless serum remains. A much more cruel method of preparation for slaughter used to be practised, though now much less frequently, in regard to the bull. By some ancient municipal laws, no butcher was allowed to expose any bull beef for sale unless it had been previously bated. The reason of this regulation probably was, that baiting had the effect of rendering the flesh or muscular fibre much more tender; for it is a universal law of the animal economy that, when animals have undergone excessive fatigue immediately before death, or have suffered from a lingering death, their flesh, though it becomes sooner ridged, also becomes sooner tender than when suddenly deprived of life in a state of health. The flesh of bunted animals also is soon tender and soon spoils (*Recherches de Physiologie et de Chimie Pathologique, par. P. N. Nysten. 8vo. Paris, 1811.*); and it is upon this principle only, that the quality of pig's flesh could be improved by the horrid cruelty, said to be practised by the Germans, of whipping the animal to death.

---

### BOOK III.

#### OF THE STUDY OF THE MINERAL KINGDOM AND THE ATMOSPHERE, WITH REFERENCE TO AGRICULTURE.

2053. The nature of the vegetable and animal kingdom having undergone discussion, the next step in the study of the science of agriculture is to enquire into the *composition and nature of material bodies, and the laws of their changes*. The earthy matters which compose the surface of the earth, the air and light of the atmosphere, the water precipitated from it, the heat or cold produced by the alternation of day and night, and by chemical composition and resolution, include all the elements concerned in vegetation. These elements have all been casually brought into notice in the study of the vegetable kingdom; but we shall now examine more minutely their properties, in so far as they are connected with cultivation. To study them completely, reference must be had to systems of chemistry and natural philosophy, of which those of Dr. Thomson (*System of Chemistry*), and Dr. Young, (*Lectures on Natural Philosophy*), may be especially recommended.

---

#### CHAP. I.

##### *Of Earths and Soils.*

2054. *Earths are the productions of the rocks which are exposed on the surface of the globe, and soils are earths mixed with more or less of the decomposed organised matter afforded by dead plants and animals.* Earths and soils, therefore, must be as various as the rocks which produce them, and hence to understand their nature and formation it is necessary to begin by considering the geological structure of the territorial surface, and the manner in which earths and soils are produced. We shall next consider in succession the Nomenclature, Quality, Use, and Improvement of Soils.

##### SECT. I. *Of the Geological Structure of the Globe and the Formation of Earths and Soils.*

2055. The crust, or *under surface of the earth*, is considered by geologists as presenting four distinct series of rocky substances; the first, supposed to be coeval with the world, are called primitive, and consist chiefly of granite and marble, below which man has not yet penetrated. The second series, called by the Wernerians transition-rocks, are of more recent formation, and seem to have resulted from some great catastrophe, (probably that to which history gives the name of deluge,) tearing up and modifying the former order of things. Clay-slate is one of the principal rocks of this class, and next limestone, sandstone, and trap or whinstone. The third series are called secondary rocks, and seem to owe their formation to partial or local revolutions, as indicated by their comparatively soft or fragile structure, superincumbent situation, and nearly horizontal position. They are chiefly limestones, sandstones, and conglomerations of fragments of other rocks, as plum-pudding-stone, &c. and appear rather as mechanical deposits from water than as chemical compounds from fusion or solution. A fourth stratum consists of alluvial or earthy depositions from water, in the form chiefly of immense beds of clays, marls, or sands. These strata are far from being regular in any one circumstance; sometimes one



or more of the strata are wanting, at other times the order of their disposition seems partially inverted; their continuity of surface is continually interrupted, so that a section of the earth almost every where exhibits only confusion and disorder to persons who have not made geology more or less their study.

2056. *The situation of the mineral productions of England*, is thus given by Bakewell. From the western side of the county of Dorset, a waving line to Scarborough (fig. 244. \* a, a) will part off, towards the

244 \*



a			b			c		
1. York.	7. Northampton	1. Durham	6. Leicester	11. Lancaster	16. Worcester	1. Richmond		
2. Doncaster	8. Oxford	2. Whitby	7. Warwick	12. Liverpool	17. Shrewsbury	2. Skipton		
3. Lincoln	9. London	3. Scarborough	8. Stow	13. Chester	18. Leominster	3. Aberconwy		
4. Yarmouth	10. Winchester	4. Nottingham	9. Bath	14. Nantwich	19. Monmouth	4. Caernarvon		
5. Norwich	11. Brighton	5. Derby	10. Exeter	15. Stafford	20. Caermerthen	5. Bala		
6. Huntingdon						6. Bodmin		

German ocean, the chalk, calcareous sandstone, and other secondary strata or alluvial earths, in which no beds of workable coal or metallic veins occur. On the coast of Lincolnshire, and part of Yorkshire, there is a subterraneous forest (b) about seventeen feet under the present high water mark, and which seems to have extended eastward in the sea to a considerable distance. West of the line between Scarborough and Hull, the county is composed of secondary strata of different kinds, in many parts of which are beds of ironstone and coal. This district is bounded on the north by mountains of metalliferous limestone, which terminate in Derbyshire, and extend in the west to the mountains of Wales and Devonshire (c, c, c, c). No metallic veins are found east of this line (c, c, c, c) in any part of England. Along the western side of the island the primary and transition mountains are situated, in which metallic ores occur. They constitute the highest parts of England, extending from Cornwall and Devonshire, through Wales, into the north-west parts of Yorkshire and Lancashire, and through Westmoreland and Cumberland, and from thence to the northern part of Scotland. All the rock salt and brine springs are situated in a line extending from the neighborhood of Nantwich nearly to Stow-on-the-Wold (e e). See Bakewell's *Geology*, page 13; and, for more particular details, Smith's, or Greenough's *Map of England*; and also Smith's very valuable *County Geological Maps*.

2057. *The succession of alluvial, secondary, transition, and primary strata, in England*, has been illustrated by Professor Brande (*Outlines of Geology*) by two sections, supposed to be taken through them. The first section (fig. 245.) commences with the blue clay of London (1), and proceeding westward through the counties of Berkshire, Hampshire, Wiltshire, Dorsetshire, and Devonshire, terminates at the Land's

End, in Cornwall. The rocks and earths presented in this line are, the Windsor alluvion (2), Hampshire and Salisbury-chalk (3), alluvion (4), sandstone (5), alluvion (6), Sherborne freestone (7), sandstone (8),

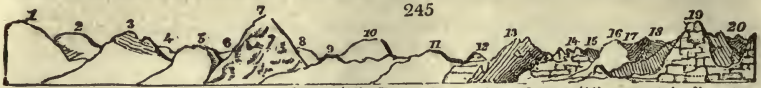

blue lias limestone (9), Blackdown sandstone (10), Devonshire red sandstone (11), mountain limestone (12), Dartmoor slate (13), granite (14), slate again (15), greenstone (16), Cornwall serpentine (17), slate killas (18), Cornwall granite (19), slate killas (20), and finally Cornwall granite.

2058. The second section (fig. 246), commences with the coal strata, and limestone resting upon slate



and granite in Cumberland, and thence proceeds towards the metropolis by Yorkshire, Derbyshire, Leicestershire, Northamptonshire, Bedfordshire, and Hertfordshire. The passage is here exhibited from the primary rocks of Cumberland to the secondary hills of the southern counties. It shows the Cumberland coal (a), limestone and slate (b), the Mossdale granite (c), slate (d), grauwacke (e), Ribblesdale limestone (f), gritstone (g), Ashton coal (h), Derby limestone (i), Derby toadstone (k), gritstone (l), gypsum (m), sandstone (n), limestone (o), Charnwood slate (p), Mountsorrel granite (q), red sandstone (r), lias limestone (s), Northampton oolite or freestone (t), Woburn sand (u), Dunstable chalk (v), and terminates in the London clay (w), with which the first section sets out.

2059. The surface earth, or that which forms the outer coating of the dry parts of the globe, is formed by the detritus, or worn off parts of rocks and rocky substances. For in some places, as in chasms and vacancies between rocky layers or masses, earth occupies many feet in depth, and in others, as on the summits of chalk hills or granite mountains, it hardly covers the surface.

2060. Earths are therefore variously composed, according to the rocks or strata which have supplied their particles. Sometimes they are chiefly formed from slate-rocks, as in blue clays; at other times from sandstone, as in siliceous soils; and mostly of a mixture of clayey, slaty, and limestone rocks, blended in proportions as various as their situations. Such we may suppose to have been the state of the surface of the dry part of the globe immediately after the last disruption of its crust; but in process of time the decay of vegetables and animals form additions to the outer surface of the earths, and constitute what are called soils; the difference between which and earths is, that the former always contain a portion of vegetable or animal matter.

2061. The manner in which rocks are converted into soils, Sir H. Davy observes (*Elem. of Agric. Chem.* 188.), may be easily conceived by referring to the instance of soft granite, or porcelain granite. This substance consists of three ingredients, quartz, feldspar, and mica. The quartz is almost pure siliceous earth in a crystalline form. The feldspar and mica are very compounded substances; both contain silica, alumina, and oxide of iron; in the feldspar there is usually lime and potassa; in the mica, lime and magnesia. When a granite rock of this kind has been long exposed to the influence of air and water, the lime and the potassa contained in its constituent parts are acted upon by water or carbonic acid; and the oxide of iron, which is almost always in its least oxidised state, tends to combine with more oxygen; and the consequence is, that the feldspar decomposes, and likewise the mica; but the first the most rapidly. The feldspar, which is as it were the cement of the stone, forms a fine clay: the mica, partially decomposed, mixes with it as sand; and the undecomposed quartz appears as gravel, or sand of different degrees of fineness. As soon as the smallest layer of earth is formed on the surface of a rock, the seeds of lichens, mosses, and other imperfect vegetables which are constantly floating in the atmosphere, and which have made it their resting-place, begin to vegetate; their death, decomposition, and decay afford a certain quantity of organisable matter, which mixes with the earthy materials of the rock; in this improved soil more perfect plants are capable of subsisting; these in their turn absorb nourishment from water and the atmosphere; and, after perishing, afford new materials to those already provided: the decomposition of the rock still continues; and at length, by such slow and gradual processes, a soil is formed in which even forest-trees can fix their roots, and which is fitted to reward the labors of the cultivator.

2062. The formation of peaty soils is produced from very opposite causes, and it is interesting to contemplate how the same effect may be produced by different means, and the earth which supplies almost all our wants may become barren alike from the excessive application of art, or the utter neglect of it. Continual pulverisation and cropping, without manuring, will certainly produce a hungry barren soil; and the total neglect of fertile tracts will, from their accumulated vegetable products, produce peat soils and bogs. Where successive generations of vegetables have grown upon a soil, Sir H. Davy observes, unless part of their produce has been carried off by man, or consumed by animals, the vegetable matter increases in such a proportion, that the soil approaches to a peat in its nature: and if in a situation where it can receive water from a higher district, it becomes spongy and permeated with that fluid, and is generally rendered incapable of supporting the nobler classes of vegetables.

2063. Spurious peaty soil. Lakes and pools of water are sometimes filled up by the accumulation of the remains of aquatic plants; and in this case a sort of spurious peat is formed. The fermentation in these cases, however, seems to be of a different kind. Much more gaseous matter is evolved; and the neighborhood of morasses, in which aquatic vegetables decompose, is usually aguish and unhealthy; whilst that of the true peat, or peat formed on soils originally dry, is always salubrious.

2064. Soils may generally be distinguished from mere masses of earth by their friable texture, dark color, and by the presence of some vegetable fibre or carbonaceous matter. In uncultivated grounds, soils occupy only a few inches in depth on the surface, unless in crevices, where they have been washed in by rains; and in cultivated soils their depth is generally the same as that to which the implements used in cultivation have penetrated.

2065. Much has been written on soils, and till lately, to very little purpose. All the Roman authors on husbandry treated the subject at length; and in modern times, in this country, copious philosophical discourses on soils were published by Bacon, Evelyn, Bradley, and others; but it may be truly said, that in no department of cultivation was ever so much written of which so little use could be made by practical men.

## SECT. II. Classification and Nomenclature of Soils.

2066. Systematic order and an agreed nomenclature are as necessary in the study of soils as of plants or animals. The number of provincial terms for soils which have found their way into the books on cultivation, is one reason why so little use can be made of their directions.

2067. A correct classification of soils may be founded on the presence or absence of organic and inorganic matter in their basis. This will form two grand classes, viz. primitive soils, or those composed entirely of inorganic matter, and secondary soils, or those composed of organic and inorganic matter in mixtures. These classes may be

subdivided into orders founded on the presence or absence of saline, metallic, and carbonic matter. The orders may be subdivided into genera founded on the prevailing earths, salts, metals, or carbon; the genera into species founded on their different mixtures; the species into varieties founded on color, or texture; and sub-varieties founded on moisture, dryness, richness, lightness, &c.

2068. *In naming the genera of soils*, the first thing is to discover the prevailing earth or earths; either the simple earths, as clay, lime, sand, or the particular rocks from which the soil has been produced, as granite, basalt, &c. When one earth prevails, the generic name should be taken from that earth, as clayey soil, calcareous soil, &c.; when two prevail to all appearance equally, then their names must be conjoined in naming the genus, as clay and sand, lime and clay, basalt and sand, &c. The great thing is precision in applying the terms. Thus, as Sir H. Davy has observed, the term sandy soil should never be applied to any soil that does not contain at least seven eighths of sand; sandy soils that effervesce with acids should be distinguished by the name of calcareous sandy soil, to distinguish them from those that are siliceous. The term clayey soil should not be applied to any land which contains less than one sixth of impalpable earthy matter, not considerably effervescing with acids; the word loam should be limited to soils, containing at least one third of impalpable earthy matter, copiously effervescing with acids. A soil to be considered as peaty, ought to contain at least one half of vegetable matter. In cases where the earthy part of a soil evidently consists of the decomposed matter of one particular rock, a name derived from the rock may with propriety be applied to it. Thus, if a fine red earth be found immediately above decomposing basalt, it may be denominated basaltic soil. If fragments of quartz and mica be found abundant in the materials of the soil, which is often the case, it may be denominated granitic soil; and the same principles may be applied to other like instances. In general, the soils, the materials of which are the most various and heterogeneous, are those called alluvial, or which have been formed from the depositions of rivers; and these deposits may be designated as siliceous, calcareous, or argillaceous; and in some cases the term saline may be added as a specific distinction, applicable, for example, at the embouchure of rivers, where their alluvial remains are overflown by the sea.

2069. *In naming the species of soils*, greater nicety is required to determine distinctions than in naming the genera; and there is also some difficulty in applying or devising proper terms. The species are always determined by the mixture of matters, and never by the color or texture of that mixture which belongs to the nomenclature of varieties. Thus a clayey soil with sand is a sandy clay, this is the name of the species; if the mass is yellow, and it is thought worth while to notice that circumstance, then it is a yellow sandy clay, which express at once the genus, species, and variety. A soil containing equal parts of clay, lime, and sand, would, as a generic term, be called clay, lime, and sand; if it contained no other mixture in considerable quantity, the term entire, might be added as a specific distinction; and if notice was to be taken of its color or degree of comminution, it might be termed a brown, a fine, a coarse, a stiff, or a free entire clay, lime, and sand.

2070. The following *Table enumerates the more common genera, species, and varieties of soils*. The application of the terms will be understood by every cultivator, though to attempt to describe the soils either chemically, or empirically (as by sight, smell, or touch), would be a useless waste of time. From a very little experience in the field or garden, more may be gained in the study of soils, than from a volume of such descriptions. This table corresponds with the nomenclature adopted in the agricultural establishments of Fellenberg at Hofwyl in Switzerland, of Professor Thaer at Mœgeln in Prussia, of Professor Thouin in his lectures at Paris, and in general with that of all the continental professors. It is therefore very desirable that it should become as generally adopted as that of the Linnæan system in botany. The principle of the table may be extended so as to include any other soil whatever.

Class.	Order.	Genus.	Species.	Variety.	Sub-Variety.		
Primitive Soils.	Earths alone	Clay	Entire	Black	Moist		
				Dry.			
				Rich.			
				Poor.			
				Sterile.			
	Earths and Salts or Metals.	Lime	Entire	Entire	Red	Moist, dry, &c.	
					Yellow	Moist, dry, &c.	
					Coarse	Moist, dry, &c.	
					Fine	Moist, dry, &c.	
					Black, red, yellow, coarse, fine, &c.	Moist, dry, rich, &c.	
		Clay	Ferruginous	Cupreous	Saline	Black, red, yellow, coarse, fine, &c.	Moist, dry, &c.
						Black, red, &c.	Moist, dry, &c.
						Black, red, &c.	Moist, dry, &c.
						Black, red	Moist, dry, &c.
						Black, red	Moist, dry, &c.
		Lime	Ferruginous	Cupreous	Saline	Black, red, yellow, coarse, fine, &c.	Moist, dry, rich, &c.
						Black, red, yellow, coarse, fine, &c.	Moist, dry, rich, &c.
						Black	Moist, dry, &c.
						Black	Moist, dry, &c.
						Black	Moist, dry, &c.
	Sand	Loamy	Peaty	Mouldy	Black, red, yellow, &c.	Moist, dry, &c.	
					Black	Moist, dry, &c.	
					Black	Moist, dry, &c.	
					Black	Moist, dry, &c.	
					Black	Moist, dry, &c.	
Earths and organic remains alone.	Clay	Limy	Sandy	Black	Moist.		
				Black	Moist.		
				Black	Moist.		
				Black, red, yellow, &c.	Moist, dry.		
				Black	Moist.		
	Lime	Loamy	Peaty	Mouldy	Black	Moist.	
					Black	Moist.	
					Black	Moist.	
					Black	Moist.	
					Black	Moist.	
	Sand	Loamy	Peaty	Mouldy	Black	Moist.	
					Black	Moist.	
					Black	Moist.	
					Black	Moist.	
					Black	Moist.	
Secondary Soils.	Clay	Ferruginous, loamy, &c.	Ferruginous, limy, &c.	Black	Moist.		
				Black	Moist.		
				Black	Moist.		
				Black	Moist.		
				Black	Moist.		
	Lime	Ferruginous, peaty, &c.	Ferruginous, mouldy, &c.	Cupreous, loamy, &c.	Black	Moist.	
					Black	Moist.	
					Black	Moist.	
					Black	Moist.	
					Black	Moist.	
	Sand	Saline, loamy, &c.	Cinereous, loamy, &c.	Ferruginous, loamy, &c.	Black	Moist.	
					Black	Moist.	
					Black	Moist.	
					Black	Moist.	
					Black	Moist.	
Earths with organic remains, metals, salts, and rocks.	Granite	Cinereous, loamy, &c.	Ferruginous, &c.	Black	Moist.		
				Black, red, yellow, &c.	Moist, dry, &c.		
				Black	Moist.		
	Basalt	Quartzose, &c.	Ferruginous, &c.	Columnar, &c.	Black, red, yellow, &c.	Moist, dry, &c.	
					Black	Moist.	
					Black	Moist.	
	Schist	Whinstone, &c.	Ferruginous, &c.	Fragile, &c.	Black, red, yellow, &c.	Moist, &c.	
					Black	Moist.	
					Black	Moist.	
	Sandstone	Micaeous, &c.	Chlorite, &c.	Ferruginous, &c.	Black, &c.	Moist, &c.	
					Black	Moist.	
					Black	Moist.	
	Limestone	Calcareous, &c.	Argillaceous, &c.	Cupreous, &c.	Black	Moist.	
					Black	Moist.	
					Black	Moist.	
Coal	Chalky, &c.	Marble, &c.	Shelly, &c.	Black, red, &c.	Moist, dry, &c.		
				Black	Moist.		
				Black	Moist.		

SECT. III. Of discovering the Qualities of Soils.

2071. The value of soils to the cultivator, is discoverable botanically, chemically, and mechanically; that is, by the plants that grow on them naturally; by chemical analysis; and by exterior and interior inspection of handling.

SUBJECT. 1. Of discovering the Qualities of Soils by means of the Plants which grow on them.

2072. Plants are the most certain indicators of the nature of a soil; for while no practical cultivator would engage with land of which he knew only the results of a chemical analysis, or examined by the sight and touch a few bushels which were brought to him, yet every gardener or farmer, who knew the sort of plants it produced, would be at once able to decide as to its value for cultivation.

2073. The leading soils for the cultivator are the clayey, calcareous, sandy, ferruginous, peaty, saline, moist or aquatic, and dry. The following are the plants by which such soils are distinguished in most parts of Europe: —

2074. Argillaceous. Tussilago farfara, Potentilla anserina, argentea, and reptans. Thalictrum flavum, Carex, many species. Juncus, various species. Orobus tuberosus,

*Lotus major*, and *corniculatus*. *Saponaria officinalis*. But the *Tussilago farfara* is a certain and universal sign of an argillaceous soil, and is the chief plant found on the alluvial grounds of Britain, France, and Italy.

2075. *Calcareous*. *Veronica spicata*, *Gallium pusillum*, *Lithospermum officinale*, and *purpureo-cæruleum*. *Campanula glomerata*, and *hybrida*. *Phyteuma orbicularis*, *Verbascum lychnitis*, *Viburnum lantana*, *Berberis vulgaris*, *Cistus helianthemum*, *Anemone pulsatilla*, *Clematis vitalba*, *Hedysarum onobrychis*.

2076. *Siliceous*. *Veronica triphyllus*, and *verna*. *Echium italicum*, *Hernaria glabra*, and *hirsuta*. *Silene anglica* and other species. *Arenaria rubra*, &c. *Spergula arvensis*, *Papaver hybridum*, *Argemone*, &c.

2077. *Ferrugineous*. *Rumex acetosa*, and *acetosella*.

2078. *Peaty*. *Vaccinium myrtillus*, *uliginosum*, and *oxycoccus*. *Erica* 4 sp. *Spergula subulata*. *Tormentilla officinalis*.

2079. *Saline*. *Salicornia* 4 species. *Zostera marina*, *Ruppia maritima*, *Pulmonaria maritima*, *Convolvulus soldanella*, *Illecebrum verticillatum*, *Chenopodium maritimum*, *Salsola kali*, and *fruticosa*. *Sium verticillatum*. *Arenaria maritima*, &c. *Atriplex laciniata*.

2080. *Aquatic*. *Caltha palustris*, *Hippuris vulgaris*. *Pinguicula vulgaris*, *Lycopus europeus*, *Valeriana dioica*, *Viola palustris*, *Samolus valerandi*, *Silenum palustre*, *Epilobium tetragonum*, *Lythrum salicaria*, *Ranunculus lingua*, and *flamula*.

2081. *Very dry*. *Arenaria rubra*, *Rumex acetosella*, *Thymus Serpyllum*, *Acinos vulgaris*, *Trifolium arvense*.

2082. *These plants are not absolutely to be depended on, however, even in Britain; and in other countries they are sometimes found in soils directly opposite. Still, the saintfoin is almost always an indication of a calcareous soil; the common coltsfoot (Tussilago farfara), of blue clay; the arenaria rubra, of poor sand; the small wood-sorrel of the presence of iron, or of peat. The common reed-grass (Arundo phragmites), and the common pond weed (Polygonum amphibium), grow on alluvial soils, which yield excellent crops if properly drained; but where the field horse-tail (Equisetum arvense) grows freely, it indicates a cold and retentive subsoil. The field pimpernell (Anagallis arvensis), the field madder (Sherardia arvensis), the corn gromwell (Lithospermum arvense), and the lamb's lettuce (Fedia olitoria), grow on cultivated lands, where the soil is a strong black loam on a dry bottom; when such a soil is wet, the clown's all-heal (Stachys palustris) makes its appearance. A light sandy soil is known by the presence of the red dead nettle (Lamium purpureum); the shepherd's purse (Thlaspi bursa pastoris). If the parsley piert (Aphanes arvensis) is found, the soil is rather unproductive; if the corn spurry (Spergula arvensis) grows very thick, the ground has likely been rendered too fine by the harrow; the common ragwort (Senecio Jacobæa), and the corn thistle (Serratula arvensis); grow indiscriminately on light and strong loams, but always indicate a fertile soil. The whitlow grass (Draba muralis), and the common knawel (Scleranthus annuus), grow on soils that are dry, sandy, and poor in the extreme. The common rest harrow (Ononis hircina) is often found, on dry pasture, and where the soil is incumbent on rotten rock. The aquatic, peaty, and saline soils are almost every where indicated by their appropriate plants; a proof, as we have before stated, that the climate and natural irrigation of plants have much more influence on their habits than mere soil. (See the Stations of Plantarum of Lin. and the Flora Française of De Candolle; Galpin's Compendium, Flora Brit.; Smith's Flora Brit.; Kent's Hints; and Farmers' Mag. Feb. 1819.)*

#### SUBJECT. 2. *Of discovering the Qualities of Soils by Chemical Analysis.*

2083. *Chemical analysis is much too nice an operation for general purposes. It is not likely that many practical cultivators will ever be able to conduct the analytic process with sufficient accuracy, to enable them to depend on the result. But still such a knowledge of chemistry as shall enable the cultivator to understand the nature of the process and its results, when made and presented to him by others, is calculated to be highly useful, and ought to be acquired by every man whose object is to join theoretical to practical knowledge. If it so happens that he can perform the operations of analysis himself, so much the better, as far as that point is concerned; but on the whole, such knowledge and adroitness is not to be expected from men who have so many other points demanding their attention, and who will, therefore, effect their purpose much better by collecting proper specimens of the soils to be studied, and sending them for analysis to a respectable operative chemist.*

2084. *In selecting specimens, where the general nature of the soil of a field is to be ascertained, portions of it should be taken from different places, two or three inches below the surface, and examined as to the similarity of their properties. It sometimes happens, that upon plains, the whole of the upper stratum of the land is of the same kind, and in this case, one analysis will be sufficient; but in valleys, and near the beds of rivers, there are very great differences, and it now and then occurs that one part of a field is calcareous,*

and another part siliceous; and in this case, and in analogous cases, the portions different from each other should be separately submitted to experiment. Soils, when collected, if they cannot be immediately examined, should be preserved in phials quite filled with them, and closed with ground glass stoppers. The quantity of soil most convenient for a perfect analysis is from two to four hundred grains. It should be collected in dry weather, and exposed to the atmosphere till it becomes dry to the touch.

2085. *The soil best suited for culture*, according to the analysis of Bergman, contains four parts of clay, three of sand, two of calcareous earth, and one of magnesia; and, according to the analysis of Fourcroy and Hassenfratz, 9216 parts of fertile soil contained 305 parts of carbon, together with 279 parts of oil; of which, according to the calculations of Lavoisier, 220 parts may be regarded as carbon: so that the whole of the carbon contained in the soil in question may be estimated at about 525 parts, exclusive of the roots of vegetables, or to about one sixteenth of its weight. Young observed that equal weights of different soils, when dried and reduced to powder, yielded by distillation quantities of air somewhat corresponding to the ratio of their values. The air was a mixture of fixed and inflammable airs, proceeding probably from decomposition of the water; but, partly, it may be presumed, from its capacity of abstracting a portion of air from the atmosphere, which the soil at least is capable of doing. The following is the analysis of a fertile soil, as occurring in the neighborhood of Bristol:—In 400 grains, there were of water, 52; siliceous sand, 240; vegetable fibre, 5; vegetable extract, 3; alumine, 48; magnesia, 2; oxide of iron, 14; calcareous earth, 30; loss, 6. But Kirwan has shown in his *Geological Essays*, that the fertility of a soil depends in a great measure upon its capacity for retaining water; and if so, soils containing the same ingredients must be also equally fertile, all other circumstances being the same; though it is plain that their actual fertility will depend ultimately upon the quantity of rain that falls, because the quantity suited to a wet soil cannot be the same that is suited to a dry soil. And hence it often happens that the ingredients of the soil do not correspond to the character of the climate. Silica exists in the soil under the modification of sand, and alumine under the modification of clay. But the one or the other is often to be met with in excess or defect. Soils in which the sand preponderates retain the least moisture; and soils in which the clay preponderates retain the most: the former are dry soils, the latter are wet soils. But it may happen that neither of them is sufficiently favorable to culture; in which case, their peculiar defect or excess must be supplied or retrenched before they can be brought to a state of fertility.

2086. *Use of the result of analysis.* In the present state of chemical science, Dr. Ure observes, no certain system can be devised for the improvement of lands, independently of experiment; but there are few cases in which the labor of analytical trials will not be amply repaid by the certainty with which they denote the best methods of melioration; and this will particularly happen, when the defect of composition is found in the proportions of the primitive earths. In supplying organic matter, a temporary food only is provided for plants, which is in all cases exhausted by means of a certain number of crops; but when a soil is rendered of the best possible constitution and texture, with regard to its earthy parts, its fertility may be considered as permanently established. It becomes capable of attracting a very large portion of vegetable nourishment from the atmosphere, and of producing its crops with comparatively little labor and expense. (*Dict. of Chem. art. Soil.*)

### SUBJECT. 3. *Of discovering the Qualities of a Soil mechanically and empirically.*

2087. *The physical properties* of soils, and some of their most important constituents relatively to the cultivator, may be ascertained to a certain extent by various and very simple means.

2088. *The specific gravity of a soil*, or the relation of its weight to that of water, may be ascertained by introducing into a phial, which will contain a known quantity of water, equal volumes of water and of soil, and this may be easily done by pouring in water till it is half full, and then adding the soil till the fluid rises to the mouth; the difference between the weight of the soil and that of the water will give the result. Thus if the bottle contains four hundred grains of water, and gains two hundred grains when half filled with water and half with soil, the specific gravity of the soil will be 2, that is, it will be twice as heavy as water, and if it gained one hundred and sixty-five grains, its specific gravity would be 1825, water being 1000.

2089. *The presence of clay and sand* in any soil is known, the first by its tenacity, the other by its roughness to the touch, and by scratching glass when rubbed on it.

2090. *The presence of calcareous matter* in soil may be ascertained by simply pouring any acid on it, and observing if it effervesces freely. Calcareous soils are also softer to the touch than any other.

2091. *The presence of organised matter in any soil may be ascertained very satisfactorily by weighing it after being thoroughly dried; then subjecting it to a red heat, and weighing it again, the weight last found will be the proportion of organic matter. The same object may also be attained by ascertaining the specific gravity of the soil, but with less accuracy.*

2092. *The presence of metallic oxides in a soil may generally be known by their color. Ferruginous soils are red or yellow; cupreous soils, interspersed with greenish streaks, &c.*

2093. *The presence of salt, sulphur, coal, &c. may be known by the absence or peculiarity of vegetation, as well as by color, and the appearance of the water of such soils.*

2094. *The capacity of a soil for retaining water may be thus ascertained. An equal portion of two soils, perfectly dry, may be introduced into two tall glass cylindrical vessels (fig. 247.), in the middle of each of which a glass tube is previously placed. The soils should be put into each in the same manner, but so as to receive a solidity approaching to that which they possessed when first obtained for trial. If, after this preparation, a quantity of water be poured into the glass tubes, it will subside; and the capillary attraction of the soils will conduct it up the cylinders towards the tops of the vessels. That which conducts it most rapidly, provided it does not rise from the weight of the incumbent column of water in the tube, may be pronounced to be the better soil. (Grisenthwaite.)*



#### SECT. IV. *Of the Uses of the Soil to Vegetables.*

2095. *Soils afford to plants a fixed abode and medium of nourishment. Earths, exclusively of organised matter and water, are allowed by most physiologists to be of no other use to plants than that of supporting them, or furnishing a medium by which they may fix themselves to the globe. But earths and organic matter, that is, soils, afford at once support and food.*

2096. *The pure earths merely act as mechanical and indirect chemical agents in the soil. The earths consist of metals united to oxygen, and these metals have not been decomposed; there is consequently no reason to suppose that the earths are convertible into the elements of organised compounds, that is, into carbon, hydrogen, and azote. Plants have been made to grow in given quantities of earth. They consume very small portions only; and what is lost may be accounted for by the quantities found in their ashes; that is to say, it has not been converted into any new products. The carbonic acid united to lime or magnesia, if any stronger acid happens to be formed in the soil during the fermentation of vegetable matter, which will disengage it from the earths, may be decomposed; but the earths themselves cannot be supposed convertible into other substances, by any process taking place in the soil. In all cases the ashes of plants contain some of the earths of the soil in which they grow; but these earths, as has been ascertained from the ashes afforded by different plants, never equal more than one fiftieth of the weight of the plant consumed. If they be considered as necessary to the vegetable, it is as giving hardness and firmness to its organisation. Thus, it has been mentioned that wheat, oats, and many of the hollow-stalked grasses, have an epidermis principally of siliceous earth; the use of which seems to be to strengthen them, and defend them from the attacks of insects and parasitical plants.*

2097. *The true nourishment of plants is water, and decomposing organic matter; both these exist only in soils, not in pure earths; but the earthy parts of the soils are useful in retaining water, so as to supply it in the proper proportions to the roots of the vegetables, and they are likewise efficacious in producing the proper distribution of the animal or vegetable matter. When equally mixed with it they prevent it from decomposing too rapidly; and by their means the soluble parts are supplied in proper proportions.*

2098. *The soil is necessary to the existence of plants, both as affording them nourishment, and enabling them to fix themselves in such a manner as to obey those laws by which their radicles are kept below the surface, and their leaves exposed to the free atmosphere. As the system of roots, branches, and leaves, are very different in different vegetables, so they flourish most in different soils; the plants that have bulbous roots require a looser and a lighter soil than such as have fibrous roots; and the plants possessing only short fibrous radicles demand a firmer soil than such as have tap-roots or extensive lateral roots.*

2099. *The constituent parts of the soil which give tenacity and coherence are the finely divided matters; and they possess the power of giving those qualities in the highest degree when they contain much alumina. A small quantity of finely divided matter is sufficient to fit a soil for the production of turnips and barley; and a tolerable crop of*

turnips has been produced on a soil containing 11 parts out of 12 sand. A much greater proportion of sand, however, always produces absolute sterility. The soil of Bagshot heath, which is entirely devoid of vegetable covering, contains less than one twentieth of finely divided matter: 400 parts of it, which had been heated red, afforded 380 parts of coarse siliceous sand; 9 parts of fine siliceous sand, and 11 parts of impalpable matter, which was a mixture of ferruginous clay with carbonate of lime. Vegetable or animal matters, when finely divided, not only give coherence, but likewise softness and penetrability; but neither they nor any other part of the soil must be in too great proportion; and a soil is unproductive if it consist entirely of impalpable matters. Pure alumina or silica, pure carbonate of lime, or carbonate of magnesia, are incapable of supporting healthy vegetation; and no soil is fertile that contains as much as 19 parts out of 20 of any of these constituents.

2100. *A certain degree of friability or looseness of texture* is also required in soils, in order that the operations of culture may be easily conducted; that moisture may have free access to the fibres of the roots, that heat may be readily conveyed to them, and that evaporation may proceed without obstruction. These are commonly attained by the presence of sand. As alumina possesses all the properties of adhesiveness in an eminent degree, and silex those of friability, it is obvious that a mixture of those two earths, in suitable proportions, would furnish every thing wanted to form the most perfect soil as to water and the operations of culture. In a soil so compounded, water will be presented to the roots by capillary attraction. It will be suspended in it, in the same manner as it is suspended in a sponge, not in a state of aggregation, but minute division, so that every part may be said to be moist, but not wet. (*Grisenthwaite.*)

2101. *The water chemically combined* amongst the elements of soils, unless in the case of the decomposition of animal or vegetable substances, cannot be absorbed by the roots of plants; but that adhering to the parts of the soil is in constant use in vegetation. Indeed there are few mixtures of the earths found in soils that contain any chemically combined water; water is expelled from the earth by most substances that combine with them. Thus, if a combination of lime and water be exposed to carbonic acid, the carbonic acid takes the place of water; and compounds of alumina and silica, or other compounds of the earths, do not chemically unite with water; and soils, at it has been stated, are formed either by earthy carbonates, or compounds of the pure earths and metallic oxides. When saline substances exist in soils, they may be united with water both chemically and mechanically; but they are always in too small a quantity to influence materially the relations of the soil to water.

2102. *The power of the soil to absorb water by cohesive attraction* depends in great measure upon the state of division of its parts; the more divided they are, the greater is their absorbent power. The different constituent parts of soils likewise appear to act, even by cohesive attraction, with different degrees of energy. Thus vegetable substances seem to be more absorbent than animal substances; animal substances more so than compounds of alumina and silica; and compounds of alumina and silica more absorbent than carbonates of lime and magnesia: these differences may, however, possibly depend upon the differences in their state of division, and upon the surface exposed.

2103. *The power of soil to absorb water from air* is much connected with fertility. When this power is great, the plant is supplied with moisture in dry seasons; and the effect of evaporation in the day is counteracted by the absorption of aqueous vapor from the atmosphere, by the interior parts of the soil during the day, and by both the exterior and interior during the night. The stiff clays approaching to pipe-clays in their nature, which take up the greatest quantity of water when it is poured upon them in a fluid form, are not the soils which absorb most moisture from the atmosphere in dry weather. They cake, and present only a small surface to the air; and the vegetation on them is generally burnt up almost as readily as on sands. The soils that are most efficient in supplying the plant with water by atmospheric absorption, are those in which there is a due mixture of sand, finely divided clay, and carbonate of lime, with some animal or vegetable matter, and which are so loose and light as to be freely permeable to the atmosphere. With respect to this quality, carbonate of lime, and animal and vegetable matter, are of great use in soils; they give absorbent power to the soil without giving it likewise tenacity; sand, which also destroys tenacity, on the contrary, gives little absorbent power. The absorbent powers of soils, with respect to atmospheric moisture, is always greatest in the most fertile soils; so that it affords one method of judging of the productiveness of land.

2104. *As examples of the absorbent powers of soils*: 1000 parts of a celebrated soil from Ormiston, in East Lothian, which contained more than half its weight of finely divided matter, of which 11 parts were carbonate of lime, and 9 parts vegetable matter, when dried at 212°, gained in an hour by exposure to air saturated with moisture, at a temperature of 62°, 18 grains. 1000 parts of a very fertile soil from the banks of the river Parret, in Somersetshire, under the same circumstances, gained 16 grains. 1000



parts of a soil from Mersea, in Essex, gained 13 grains. 1000 grains of a fine sand, from Essex, gained 11 grains. 1000 of a coarse sand gained only 8 grains. 1000 of a soil of Bagshot Heath gained only 3 grains.

2105. *The absorbent powers of soils ought to vary with the climate* in which they are situated. The absorption of moisture ought to be much greater in warm or dry countries, than in cold and moist ones; and the quantity of clay, or vegetable, or animal matter in soils greater. Soils also on declivities ought to be more absorbent than in plains or in the bottom of valleys. Their productiveness likewise is influenced by the nature of the sub-soil, or the stratum on which they rest. When soils are immediately situated upon a bed of rock or stone, they are much sooner rendered dry by evaporation than where the sub-soil is of clay or marl; and a prime cause of the great fertility of the land in the moist climate of Ireland, is the proximity of the rocky strata to the soil. A clayey sub-soil will sometimes be of material advantage to a sandy soil; and in this case it will retain moisture in such a manner as to be capable of supplying that lost by the earth above, in consequence of evaporation or the consumption of it by plants. A sandy or gravelly sub-soil often corrects the imperfections of too great a degree of absorbent power in the true soil. In calcareous countries, where the surface is a species of marl, the soil is often found only a few inches above the limestone; and its fertility is not impaired by the proximity of the rock; though in a less absorbent soil, this situation would occasion barrenness; and the sandstone and limestone hills in Derbyshire and North Wales may be easily distinguished at a distance, in summer, by the different tints of the vegetation. The grass on the sandstone-hills usually appears brown and burnt up; that on the limestone-hills flourishing and green.

2106. *In a moist climate*, where the quantity of rain that falls annually equals from 40 to 60 inches, as in Lancashire, Cornwall, and some parts of Ireland, a siliceous sandy soil is much more productive than in dry districts; and in such situations wheat and beans will require a less coherent and absorbent soil than in drier situations; and plants having bulbous roots will flourish in a soil containing as much as 14 parts out of 15 of sand. Even the exhausting powers of crops will be influenced by like circumstances. In cases where plants cannot absorb sufficient moisture, they must take up more manure. And in Ireland, Cornwall, and the western Highlands of Scotland, corn will exhaust less than in dry inland situations. Oats, particularly in dry climates, are impoverishing in a much higher degree than in moist ones.

2107. *Many soils are popularly distinguished as cold or hot*; and the distinction, though at first view it may appear to be founded on prejudice, is really just. Some soils are much more heated by the rays of the sun, all other circumstances being equal, than others; and soils brought to the same degree of heat, cool in different times, *i. e.* some cool much faster than others. This property has been very little attended to in a philosophical point of view; yet it is of the highest importance in culture. In general, soils that consist principally of a stiff white clay are difficultly heated; and being usually very moist, they retain their heat only for a short time. Chalks are similar in one respect, that they are difficultly heated; but being drier they retain their heat longer, less being consumed in causing the evaporation of their moisture. A black soil, containing much soft vegetable matter, is most heated by the sun and air; and the colored soils, and the soils containing much carbonaceous matter, or ferruginous matter, exposed under equal circumstances to the sun, acquire a much higher temperature than pale-colored soils.

2108. *When soils are perfectly dry, those that most readily become heated by the solar rays, likewise cool most rapidly*; but the darkest-colored dry soil, (that which contains abundance of animal or vegetable matter; substances which most facilitate the diminution of temperature,) when heated to the same degree, provided it be within the common limits of the effect of solar heat, will cool more slowly than a wet, pale soil, entirely composed of earthy matter. Sir H. Davy "found that a rich black mould, which contained nearly one fourth of vegetable matter, had its temperature increased in an hour from 65° to 88° by exposure to sunshine; whilst a chalk soil was heated only to 69° under the same circumstances. But the mould removed into the shade, where the temperature was 62°, lost, in half an hour, 15°; whereas the chalk, under the same circumstances, had lost only 4°. We may also refer to the influence of black earth in melting snow, as practised empirically on the Alps, and tried philosophically by Franklin and Saussure. The latter placed on the top of the high Alpine mountain Cramont, a box lined with black cloth with the side next the sun, closed by three panes of glass at a little distance apart the one from the other, and found the thermometer rise thirty degrees in two hours from the concentration of the sun's rays. (*Agriculture appliquee, &c.* tom. i. 82.) A brown fertile soil and a cold barren clay were each artificially heated to 88°, having been previously dried; they were then exposed in a temperature of 57°; in half an hour the dark soil was found to have lost 9° of heat; the clay had lost only 6°. An equal portion of the clay containing moisture, after being heated to 88°, was exposed in a temperature

of 55°; in less than a quarter of an hour it was found to have gained the temperature of the room. The soils in all these experiments were placed in small tin-plate trays two inches square, and half an inch in depth; and the temperature ascertained by a delicate thermometer. Thus the temperature of the surface, when bare and exposed to the rays of the sun, affords at least one indication of the degrees of its fertility; and the thermometer may be sometimes a useful instrument to the purchaser or improver of lands."

2109. *The moisture in the soil and sub-soil materially affects its temperature*, and prevents, as in the case of constantly saturated aquatic soils, their ever attaining to any great degree either of heat or cold. The same observation will apply to moist peaty soils, or peat-bogs.

2110. *Chemical agency of soils.* Besides these uses of soils, which may be considered mechanical, there is, Sir H. Davy observes, another agency between soils and organisable matters, which may be regarded as chemical in its nature. The earths, and even the earthy carbonates, have a certain degree of chemical attraction for many of the principles of vegetable and animal substances. This is easily exemplified in the instance of alumina and oil; if an acid solution of alumina be mixed with a solution of soap, which consists of oily matter and potassa, the oil and the alumina will unite and form a white powder, which will sink to the bottom of the fluid. The extract from decomposing vegetable matter, when boiled with pipe-clay or chalk, forms a combination by which the vegetable matter is rendered more difficult of decomposition and of solution. Pure silicia and siliceous sands have little action of this kind; and the soils which contain the most alumina and carbonate of lime, are those which act with the greatest chemical energy in preserving manures. Such soils merit the appellation, which is commonly given to them, of rich soils; for the vegetable nourishment is long preserved in them, unless taken up by the organs of plants. Siliceous sands, on the contrary, deserve the term hungry, which is commonly applied to them; for the vegetable and animal matters they contain, not being attracted by the earthy constituent parts of the soil, are more liable to be decomposed by the action of the atmosphere, or carried off from them by water. In most of the black and brown rich vegetable moulds, the earths seem to be in combination with a peculiar extractive matter, afforded during the decomposition of vegetables; this is slowly taken up or attracted from the earths by water, and appears to constitute a prime cause of the fertility of the soil.

2111. *Thus all soils are useful to plants*, as affording them a fixed abode and a range for their roots to spread in search of food; but some are much more so than others, as better adapted by their constituent parts, climate, inclination of surface and sub-soil attracting and supplying food.

#### SECT. V. *Of the Improvement of Soils.*

2112. *Soils may be rendered more fit for answering the purposes of vegetation* by pulverisation, by consolidation, by exposure to the atmosphere, by an alteration of their constituent parts, by changing their condition in respect to water, by changing their position in respect to atmospherical influence, and by a change in the kinds of plants cultivated. All these improvements are independently of the application of manures.

##### SUBJECT. 1. *Pulverisation.*

2113. *The mechanical division of the parts of soils* is a very obvious improvement, and applicable to all in proportion to their adhesive texture. Even a free siliceous soil will, if left untouched, become too compact for the proper admission of air, rain, and heat, and for the free growth of the fibres; and strong upland clays, not submitted to the plough or the spade, will, in a few years, be found in the possession of fibrous-rooted perennial grasses, which form a clothing on their surface, or strong tap-rooted trees, as the oak, which force their way through the interior of the mass. Annuals and rametaceous-rooted herbaceous plants cannot penetrate into such soils.

2114. *The first object of pulverisation is to give scope to the roots of vegetables*, for without abundance of roots no plant will become vigorous, whatever may be the richness of the soil in which it is placed. The fibres of the roots, as we have seen (1512.), take up the extract of the soil by intro-susception; the quantity taken up, therefore, will not depend alone on the quantity in the soil, but on the number of absorbing fibres. The more the soil is pulverised, the more these fibres are increased, the more extract is absorbed, and the more vigorous does the plant become. Pulverisation, therefore, is not only advantageous previous to planting or sowing, but also during the progress of vegetation, when applied in the intervals between the plants. In this last case it operates also in the way of pruning, and by cutting off or shortening the extending fibres, causes them to branch out numerous others, by which the mouths or pores of the plants are greatly increased, and such food as is in the soil has the better chance of being sought after, and taken up by them. Tull and Du Hamel relate various experiments which decidedly prove that, *ceteris paribus*, the multiplication of the fibres is as the inter-pulverisation;

but the strength of the vegetable, in consequence of this multiplication of fibres, must depend a good deal on the quantity of food or of extract within their reach. The root of a willow tree, as we have seen (1560.), has the fibres prodigiously increased by coming in contact with the water in a river, and so have various other aquatic trees and plants, as alder, mint, *lysimachia thyriflora*, *calla palustris*, *œnanthe fistulosa*, &c. ; but their herbs or trunks are not proportionally increased unless the water be impregnated with organised remains.

2115. *Pulverisation increases the capillary attraction*, or sponge-like property of soils, by which their humidity is rendered more uniform. It is evident this capillary attraction must be greatest where the particles of the earth are finely divided; for gravels and sands hardly retain water at all, while clays, not opened by pulverisation or other means, either do not absorb water, or when, by long action it is absorbed, they retain too much. Water is not only necessary to the growth of plants as such, but it is essential to the production of extract from the vegetable matters which they contain; and unless the soil, by pulverisation or otherwise, is so constituted as to retain the quantity of water requisite to produce this extract, the addition of manures will be in vain. Manure is useless to vegetation till it becomes soluble in water, and it would remain useless in a state of solution, if it so abounded as wholly to exclude air, for then the fibres or mouths, unable to perform their functions, would soon decay and rot off. Pulverisation in a warm season is of great advantage in admitting the nightly dews to the roots of plants: Chaptal, in his *Agriculture appliqué à Chimie*, relates the great benefit he found from the practice in this respect to his corn crops; and shows of what importance it is in the culture of vineyards in France.

2116. *The temperature of a soil is greatly promoted by pulverisation*. Earths, Grisenthwaite observes, are also among the worst conductors of heat with which we are acquainted, and consequently, it would be a considerable time before the gradually increasing temperature of spring could communicate its genial warmth to the roots of vegetables, if their lower strata were not heated by some other means. To remove this defect, which always belongs to a close compact soil, it is necessary to have the land open, that there may be a free ingress of the warm air and tepid rains of spring.

2117. *Pulverisation contributes to the increase of vegetable food*. Water is known to be a condenser and solvent of carbonic acid gas, which, when the land is open, can be immediately carried to the roots of vegetables, and contribute to their growth; but if the land be close, and the water lie on or near its surface, then the carbonic acid gas, which always exists in the atmosphere and is carried down by rains, will soon be dissipated. An open soil is also almost suitable for affecting those changes in the manure itself, which are equally necessary to the preparation of such food. Animal and vegetable substances, exposed to the alternate action of heat, moisture, light, and air, undergo spontaneous decompositions, which would not otherwise take place.

2118. *By means of pulverisation a portion of atmospheric air is buried in the soil*. This air, so confined, is decomposed by the moisture retained in the earthy matters. Ammonia is formed by the union of the hydrogen of the water with the nitrogen of the atmosphere; and nitre, by the union of oxygen and nitrogen; the oxygen may also unite with the carbon contained in the soil, and form carbonic acid gas, and carburetted hydrogen. Heat is given out during these processes, and "hence," as Dr. Darwin remarks (*Phytologia*, sect. xii. 1.), "the great propriety of cropping lands immediately after they had been comminuted and turned over; and this the more especially, if manure has been added at the same time, as the process of fermentation will go on faster when the soil is loose, and the interstices filled with air, than afterwards, when it becomes compressed with its own gravity, the relaxing influence of rains, and the repletion of the partial vacuums formed by the decomposition of the enclosed air. The advantage of the heat thus obtained in exciting vegetation, whether in a seed or root, especially in spring, when the soil is cold, must be very considerable."

2119. *The great advantages of pulverisation deceived Tull*, who fancied that no other assistances were required in the well-management of the business of husbandry. A knowledge of chemistry, in its present improved state, would have enabled him to discover that the pulverisation of the soil was of no other benefit to the plants that grow in it than as it "increased the number of their fibrous roots or mouths by which they imbibe their food, facilitated the more speedy and perfect preparation of this food, and conducted the food so prepared more regularly to their roots." Of this food itself it did not produce one particle.

2120. *The depth of pulverisation*, Sir H. Davy observes, "must depend upon the nature of the soil, and of the subsoil. In rich clayey soils it can scarcely be too deep; and even in sands, unless the subsoil contains some principles noxious to vegetables, deep comminution should be practised. When the roots are deep, they are less liable to be injured either by excessive rain or drought; the radicles are shot forth into every part of the soil;

and the space from which the nourishment is derived is more considerable than when the seed is superficially inserted in the soil."

2121. *Pulverisation should, in all cases, be accompanied with the admixture of the parts of soils by turning them over.* It is difficult, indeed, to pulverise without effecting this end, at least by the implements in common use; but if it could be effected, it would be injurious, because the difference of gravity between the organised matters and the earths has a constant tendency to separate them, and stirring a soil only by forks or pronged implements, such as cultivators, would, in a short time, leave the surface of the soil too light and spongy, and the lower part too compact and earthy.

SUBJECT. 2. *Of the Improvement of Soils by Compression.*

2122. *Mechanical consolidation* will improve some soils, such as spongy peats and light dusty sands. It is but a limited source of improvement, but still it deserves to be noticed.

2123. *The proper degree of adhesiveness* is best given to loose soils by the addition of earthy matters; but mere rolling and treading are not to be altogether rejected. To be benefited by rolling a soil must be dry, and the operation must not be carried too far. A peat-bog drained and rolled, will sooner become covered with grasses than one equally well drained and left alone. Drifting sands may be well rolled when wet, and by repeating the process after rains they will in time acquire a surface of grass or herbage. Every agriculturist knows the advantages of rolling light soils after sowing, or even treading them with sheep. Gardeners also tread in seeds on certain soils.

SUBJECT. 3. *Of the Improvement of Soils by Aeration or Fallowing.*

2124. *Soils are benefited by the free admission of the weather to their interior parts.* This is generally considered as one of the advantages of fallowing, and its use in gardening is experienced in compost heaps, and in winter and summer ridging. The precise advantages, however, of exposure to the air, independently of the concurrent influence of water, heat, and the other effects mentioned as attendant on pulverisation, do not seem at present to be correctly ascertained. It is allowed that carbonic acid gas may be absorbed by calcareous earths, and Dr. Thomson considers that the earths alone may thus probably administer food to plants; but Sir H. Davy seems to consider mere exposure to the atmosphere of no benefit to soils whatever. "It has been supposed by some writers," he says, "that certain principles necessary to fertility are derived from the atmosphere, which are exhausted by a succession of crops, and that these are again supplied during the repose of the land, and the exposure of the pulverised soil to the influence of the air; but this in truth is not the case. The earths commonly found in soils cannot be combined with more oxygen; none of them unite to azote; and such of them as are capable of attracting carbonic acid, are always saturated with it in those soils on which the practice of fallowing is adopted."

2125. *Aeration and repose, or summer fallow.* "The vague ancient opinion of the use of nitre, and of nitrous salts in vegetation," Sir H. Davy says, "seems to have been one of the principal speculative reasons for the defence of summer fallows. Nitrous salts are produced during the exposure of soils containing vegetable and animal remains, and in greatest abundance in hot weather; but it is probably by the combination of the azote from these remains with oxygen in the atmosphere that the acid is formed; and at the expense of an element, which otherwise would have formed ammonia; the compounds of which are much more efficacious than the nitrous compounds in assisting vegetation." It is proper to observe that this reason is more speculative than experimental, and seems influenced, in some degree, by the opinion adopted by the author, that fallows are of little use in husbandry. One obvious advantage of aeration in summer, or a summer fallow, is, that the soil may thus be heated by the sun to a degree which it never could be, if partially covered with the foliage of even the widest drilled crops. For this purpose, if the soil is laid up in large lumps, it is evident it will receive more heat by exposing a greater surface to the atmosphere, and it will retain this heat longer than can be expected, from the circumstance of the lumps reflecting back the rays of heat radiated by each other. A clayey soil, in this way, it is said (*Farmer's Magazine*, 1815), may be heated to 120°, which may in some degree alter its absorbent powers as to water, and contribute materially to the destruction of vegetable fibre, insects, and their eggs. By the aeration of lands in winter, minute mechanical division is obtained by the freezing of the water in the soil; for, as water in the solid state occupies more space than when fluid, the particles of earthy matters and of decomposing stones are thus rent asunder, and crumble down in a fine mould. Rough stony soils will thus receive an accession to their finer soil every winter.

2126. *Agricultural experience* has fully proved that fallows are the only means by which stiff clays in moist climates can be effectually cleared of weeds. Supposing therefore that no other advantage whatever was obtained, that no nutritive matter was imbibed from the atmosphere, and the soil was neither chemically nor mechanically

benefited by aeration, this benefit alone—the effectual eradication of weeds—is sufficient to justify the use of fallows on such soils.

2127. *Many of the objections to fallows* have arisen in consequence of the parties not previously agreeing as to what a summer fallow is. In England generally, or at least formerly, a fallow was a portion of land, left a year without culture or cropping, unless being once or twice ploughed can be denominated the former, and an abundant growth of coarse grasses and weeds can constitute the latter. The *jachères* of the French are the same thing. In Scotland and the best cultivated districts a summer fallow is a portion of land which is begun to be cultivated after the crop is removed in autumn, and is frequently, as need requires, ploughed, harrowed, and otherwise comminuted, and freed from stones, weeds, inequalities, &c., till the autumnal seed-time of the following year: it is thus for twelve months in a state of constant tillage and movement. The result is that the land is thoroughly freed from roots of weeds; from many seeds of weeds, which are thus made to germinate, and are then destroyed; and from many eggs of insects which are thus hatched, but being without plants to nourish them in their larva state, speedily die. The land is also thoroughly pulverised, and the top, bottom, and middle, mixed together; stones are picked out, inequalities unfavorable to surface drainage removed or lessened, and various other useful objects attained. Such a fallow can no more be compared with what usually passes under that name, than the plough of Virgil (112.) with that of Small.

2128. *That fallows of the common kind* are much more universal than is necessary, there can be little doubt; but there can be as little doubt that fallows such as we have described, are much less frequent than they should be; and that wherever they are practised, the agriculturist's produce and profits will be found far superior to where they are omitted; turnip soils are of course to be excepted, because the preparation for that crop on light soils effects the same purpose in eight months, that the other does in twelve.

2129. *The origin of fallows* is commonly traced to the idea, that land naturally requires rest as well as animals: but a want of hands first, and afterwards a want of manure, is a much more likely cause. Men must very early have observed, from what took place in the spots they cultivated as gardens, that pulverisation and manure would ensure perpetual crops on the same soil; but they must at the same time have felt, that they had neither the requisite laborers to bestow the cultivation, nor cattle to produce the manure. Hence they would find it easier to break up one piece of fresh ground after another, and after they had gone a round in this way, as extensive as their limits or other circumstances permitted, they would return to where they began. As their limits became circumscribed by the increase of population, or other causes, they would return the oftener, till at last, when property became more rigidly defined, and more valuable, they would return at short intervals regularly. Then it was that the necessity and advantage of working fallows would be felt, and the practice become systematised as at the present day, and from the earliest records in civilized countries. The practice of fallowing in Italy, during the time of the Romans (128.) differed in nothing from that of the same country, and throughout the rest of Europe at the present day: and if we trace field culture among savage and semibarbarous nations, and gradually through such as are more wealthy and refined, we shall find the fallow in all its gradations, from breaking up at random, to the septennial operations of the best British farmers.

SUBJECT. 4. *Alteration of the constituent Parts of Soils.*

2130. *The constituent parts of soils may be altered by the addition or subtraction of ingredients* in which they are deficient, or superabound, and by the chemical changes of some constituent part or parts by the action of fire.

2131. *In ascertaining the composition of faulty soils with a view to their improvement by adding to their constituent parts*, any particular ingredient which is the cause of their unproductiveness should be particularly attended to; if possible, they should be compared with fertile soils in the same neighborhood, and in similar situations, as the difference of the composition may, in many cases, indicate the most proper methods of improvement. If, on washing a sterile soil, it is found to contain the salts of iron, or any acid matter, it may be ameliorated by the application of quick lime. A soil of good apparent texture, containing sulphate of iron, will be sterile; but the obvious remedy is a top-dressing with lime, which converts the sulphate into manure. If there be an excess of calcareous matter in the soil, it may be improved by the application of sand or clay. Soils too abundant in sand are benefited by the use of clay, or marl, or vegetable matter. Light sands are often benefited by a dressing of peat, and peats by a dressing of sand; though the former is in its nature but a temporary improvement. When peats are acid, or contain ferruginous salts, calcareous matter is absolutely necessary in bringing them into cultivation. The best natural soils are those of which the materials have been derived from different strata, which have been minutely divided by air and water, and are intimately blended together; and in improving soils artificially, the cultivator cannot do better than imitate the processes of nature. The materials necessary for the purpose are seldom far distant; coarse sand is often found immediately on chalk, and beds of sand and gravel are common below clay. The labor of improving the texture or constitution of the soil is repaid by a great permanent advantage,—less manure is required, and its fertility insured; and capital laid out in this way secures for ever the productiveness, and consequently the value of the land.

2132. *The removal of superabundant ingredients in soils* may sometimes be one of the

simplest and most effectual means of their improvement. It occasionally happens that the surface of a well proportioned soil is thickly covered with peat, with drifted sand, with gravel, or with small stones. Extensive examples of the former occur in Stirlingshire, and of the latter in Norfolk. In such cases, a simple and effectual mode of improvement consists in removing the superincumbent strata, and cultivating that below. This can seldom be put in practice on a large scale, with such heavy materials as gravel or stones; but some hundreds of acres of rich alluvial soil, deeply covered by peat, have been bared and cultivated in Flanders moss in Stirlingshire; an operation commenced by the celebrated Lord Kaimes, (*Gen. Rep. of Scot. App. v. 5.*) copied by his neighbors, and continued by his and their successors. The moss is floated off by streams of water, which empty themselves in the Frith of Forth. In this river, by the winds and tides, it is cast on shore in the bays and recesses, impregnated with salt; and here it ingenders vegetation on the encroaching surfaces of sand and gravel. Coatings of sand or gravel can seldom be removed on a scale of sufficient extent for agriculture, but have, in some instances, for the purposes of gardening. Sometimes this improvement may be effected by trenching down the surface, and raising up a stratum of better earth.

2133. *Incineration.* The chemical changes which can be effected in soils by incineration are considerable. This practice was known to the Romans, is more or less in use in most parts of Europe, is mentioned as an approved practice by our oldest agricultural writers, and has lately excited some degree of attention from the successful experiments of different cultivators. (*Farmer's Magazine*, 1810 to 1815, and *Farmer's Journal*, 1814 to 1821.)

2134. *The theory of burning soils* is thus given by Sir H. Davy. It rests, he says, entirely on chemical doctrines. The bases of all common soils are mixtures of the primitive earths and oxide of iron; and these earths have a certain degree of attraction for each other. To regard this attraction in its proper point of view, it is only necessary to consider the composition of any common siliceous stone. Feldspar, for instance, contains siliceous, aluminous, calcareous earths, fixed alkali, and oxide of iron, which exists in one compound, in consequence of their chemical attractions for each other. Let this stone be ground into impalpable powder, it then becomes a substance like clay; if the powder be heated very strongly, it fuses, and on cooling forms a coherent mass similar to the original stone; the parts separated by mechanical division adhere again in consequence of chemical attraction. If the powder is heated less strongly, the particles only superficially combine with each other, and form a gritty mass, which, when broken into pieces, has the characters of sand. If the power of the powdered feldspar to absorb water from the atmosphere before, and after the application of the heat, be compared, it is found much less in the last case. The same effect takes place when the powder of other siliceous or aluminous stones is made the subject of experiment, and two equal portions of basalt ground into impalpable powder, of which one half had been strongly ignited, and the other exposed only to a temperature equal to that of boiling water, gained very different weights in the same time when exposed to air. In four hours the one had gained only two grains, whilst the other had gained seven grains. When clay or tenacious soils are burnt, the effect is of the same kind; they are brought nearer to a state analogous to that of sands. In the manufacture of bricks the general principle is well illustrated; if a piece of dried brick earth be applied to the tongue, it will adhere to it very strongly, in consequence of its power to absorb water; but after it has been burnt, there will be scarcely a sensible adhesion.

2135. *The advantages of burning* are that it renders the soil less compact, less tenacious and retentive of moisture; and when properly applied, may convert a matter that was stiff, damp, and in consequence cold, into one powdery, dry, and warm, and much more proper as a bed for vegetable life.

2136. *The great objection* made by speculative chemists to paring and burning, is, that it destroys vegetable and animal matter, or the manure in soil; but in cases in which the texture of its earthly ingredients is permanently improved, there is more than a compensation for this temporary disadvantage. And in some soils where there is an excess of inert vegetable matter, the destruction of it must be beneficial; and the carbonaceous matter remaining in the ashes may be more useful to the crop than the vegetable fibre from which it was produced.

2137. *Three specimens of ashes* from different lands that had undergone paring and burning were examined by chemical analysis. The first was from a chalk soil, and 200 grains contained 80 of carbonate of lime, 11 gypsum, 9 charcoal, 15 oxide of iron, 3 saline matter, sulphate of potash, muriate of magnesia, with a minute quantity of vegetable alkali. The remainder alumina and silica. Suppose 2660 bushels to be the common produce of an acre of ground, then, according to this calculation, they would give 172,900 lbs., containing carbonate of lime 691,60 lbs., gypsum 9509·5, oxide of iron 12,967·5, saline matter 2593·5, charcoal 7780·5. In this instance there was undoubtedly a very considerable quantity of matter capable of being active as manure pro-

duced in the operation of burning. The charcoal very finely divided, and exposed on a large surface, must be gradually converted into carbonic acid. And gypsum and oxide of iron seem to produce the very best effects when applied to lands containing an excess of carbonate of lime. The second specimen was from a soil near Colcoorton, in Leicestershire, containing only four per cent. of carbonate of lime, and consisting of three fourths light siliceous sand, and about one fourth clay. This had been turf before burning, and 100 parts of the ashes gave 6 parts charcoal, 3 muriate of soda and sulphate of potash, with a trace of vegetable alkali, 9 oxide of iron, and the remainder the earths. In this instance, as in the other, finely divided charcoal was found, the solubility of which would be increased by the presence of the alkali. The third instance was that of a stiff clay, from Mount's Bay, Cornwall. This land has been brought into cultivation from a heath, by burning, about ten years before : but having been neglected, furze was springing up in different parts of it, which gave rise to the second paring and burning, 100 parts of the ashes contained 8 parts of charcoal, 2 of saline matter, principally common salt, with a little vegetable alkali, 7 oxide of iron, 2 carbonate of lime, the remainder alumina and silica. Here the quantity of charcoal was greater than in the other instances. The salt was probably owing to the vicinity of the sea, it being but two miles off. In this land there was certainly an excess of dead vegetable fibre, as well as unprofitable living vegetable matter.

2138. *Causes of the effects of burning soil.* Many obscure causes have been referred to for the purpose of explaining the effects of paring and burning ; but they may be referred entirely to the diminution of the coherence and tenacity of clays, and to the destruction of inert and useless vegetable matter, and its conversion into a manure. Dr. Darwin, in his *Phytologia*, has supposed that clay, during torrefaction, may absorb some nutritive principles from the atmosphere that afterwards may be supplied to plants ; but the earths are pure metallic oxides, saturated with oxygen ; and the tendency of burning is to expel any other volatile principles that they may contain in combination. If the oxide of iron in soils is not saturated with oxygen, torrefaction tends to produce its further union with this principle ; and hence, in burning, the color of clay changes to red. The oxide of iron, containing its full proportion of oxygen, has less attraction for acids than the other oxide, and is consequently less likely to be dissolved by any fluid acids in the soil ; and it appears in this state to act in the same manner as the earths. A very ingenious author, Naismith (*Elements of Agr.*), supposes that the oxide of iron, when combined with carbonic acid, is poisonous to plants ; and that one use of torrefaction is to expel the carbonic acid from it ; but the carbonate of iron is not soluble in water, and is a very inert substance ; and a luxuriant crop of cresses has been raised in a soil composed of one fifth carbonate of iron, and four fifths carbonate of lime. Carbonate of iron abounds in some of the most fertile soils in England, particularly the red hop soil. And there is no theoretical ground for supposing that carbonic acid, which is an essential food of plants, should, in any of its combinations, be poisonous to them ; and it is known that lime and magnesia are both noxious to vegetation, unless combined with this principle.

2139. *The soils improved by burning* are all such as contain too much dead vegetable fibre, and which consequently lose from one third to one half their weight by incineration ; and all such as contain their earthy constituents in an impalpable state of division, *i. e.* the stiff clays and marls, are improved by burning : but in coarse sands, or rich soils containing a just mixture of the earths, and in all cases in which the texture is sufficiently loose, or the organisable matter sufficiently soluble, the process of torrefaction cannot be useful.

2140. *All poor siliceous sands are injured by burning.* Young in his *Essay on Manures*, states, "that he found burning injure sand ; and the operation is never performed by good cultivators upon siliceous sandy soils, after they have once been brought into cultivation."

#### SUBJECT. 5. *Changing the Condition of Lands, in respect to Water.*

2141. *The water of the soil where superabundant may be withdrawn, and when deficient supplied :* these operations with water are independent of its supply as a manure, or as affording the stimulus of heat or cold.

2142. *Stagnant water* may be considered as injurious to all the useful classes of plants, by obstructing perspiration and intro-susception, and thus diseasing their roots and submerged parts. Where the surface-soil is properly constituted, and rests on a subsoil moderately porous, both will hold water by capillary attraction, and what is not so retained will sink into the interior strata by its gravity ; but where the subsoil is retentive it will resist, or not admit with sufficient rapidity, the percolation of water to the strata below, which accumulating in the surface-soil, till its proportion becomes excessive as a component part, not only carries off the extractive matter, but diseases the

plants. Hence the origin of surface-draining, that is, laying land in ridges or beds, or intersecting it with small open gutters.

2143. *Springs.* Where the upper stratum is porous in some places, and retentive in others, and on a retentive base, the water, in its progress along the porous bed or layer, will be interrupted by the retentive places in a great variety of ways, and there accumulating will burst through the upper surface in the form of springs, which are more injurious than surface-water, as being colder, and generally permanent in their operation. Hence the origin of under-draining in all its varieties of collecting, extracting, and conveying water.

2144. *The water of rivers* may become injurious to lands on their banks, by too frequently overflowing their surface. In this case the stream may be included by mounds of earth or other materials impervious to water: and thus aquatic soils rendered dry and fit for useful herbage and aration. The same may be said of lands occasionally overflowed by the sea. Hence the origin of embanking, an art carried to a great extent in Holland and Italy. (See *Smeaton's Posthumous Works*; *Sigismondi, Agr. Tosc.*; and our article *Embankment*, in *Supp. Encyc. Brit.* 1819.)

2145. *Irrigation.* Plants cannot live without water, any more than they can prosper in soils where it is superabundant; and it is therefore supplied by art on a large scale, either by surface or subterraneous irrigation. In both practices the important points are to imitate nature in producing motion, and in applying the water in the mornings or evenings, or under a clouded sky, and also at moderate intervals. The effects of water constantly employed, would, in most cases, be such as attend stagnated water, aquatic soils, or land-springs; and employed in hot sunshine, or after violent heats, it may check evaporation and destroy life, exactly as happens to those who may have bathed in cold spring water after long and violent exercise in a hot day. (*Phytologia*, xv. 3. 5.)

2146. *In surface irrigation* the water is conveyed in a system of open channels, which require to be most numerous in such grounds as are under drilled annual crops, and least so in such as are sown in breadths, beds, or ridges, under perennial crops. This mode of watering has existed from time immemorial. The children of Israel are represented as sowing their seed and "watering it with their foot;" that is, as Calmet explains it, raising the water from the Nile by a machine worked by the feet, from which it was conducted in such channels as we have been describing. It is general in the south of France and Italy; but less required in Britain.

2147. *Subterraneous irrigation* may be effected by a system of drains or covered gutters in the subsoil, which, proceeding from a main conduit, or other supply, can be charged with water at pleasure. For grounds under the culture of annual plants, this mode would be more convenient, and for all others more economical as to the use of water, than surface irrigation. Where the under-stratum is gravelly, and rests on a retentive stratum, this mode of watering may take place without drains, as it may also on perfectly flat lands, by filling to the brim, and keeping full for several days, surrounding trenches; but the beds or fields between the trenches must not be of great extent. This practice is used in Lombardy on the alluvial lands near the embouchures of the Po. In Lincolnshire the same mode is practised by shutting up the flood gates of the mouths of the great drains in the dry seasons, and thus damming up the water through all the ramifications of the drainage from the sea to their source. This was first suggested by G. Rennie and Sir Joseph Banks, after the drainage round Boston, completed about 1810. A similar plan, on a smaller scale, had been practised in Scotland, where deep mosses had been drained and cultivated on the surface, but where, in summer, vegetation failed from deficiency of moisture. It was first adopted by J. Smith, (See *Essay on the Improvement of Peat-Moss*, 1795,) on a farm in Ayrshire, and has subsequently been brought into notice by J. Johnston, the first delineator and professor of Elkinson's system of draining.

2148. *Mamuring by irrigation.* Irrigation with a view to conveying additions to the soil has long been practised, and is an evident imitation of the overflowing of alluvial lands, whether in meadow or aration. In the former case it is called irrigation or flooding, and in the latter, warping. Warping is used chiefly as a mode of enriching the soil by an increase of the alluvial depositions, or warp of rivers, during winter, where the surface is not under crop, and is common on the banks of the Ouse.

2149. *The rationale of irrigation* is thus given by Sir H. Davy. "In general in nature the operation of water is to bring earthy substances into an extreme state of division. But in the artificial watering of meadows, the beneficial effects depend upon many different causes, some chemical, some mechanical. Water is absolutely essential to vegetation; and when land has been covered by water in the winter, or in the beginning of spring, the moisture that has penetrated deep into the soil, and even the subsoil, becomes a source of nourishment to the roots of the plants in the summer, and prevents those bad effects that often happen in lands in their natural state, from a long continuance of dry weather. When the water used in irrigation has flowed over a calcareous



country, it is generally found impregnated with carbonate of lime; and in this state it tends, in many instances, to ameliorate the soil. Common river water also generally contains a certain portion of organisable matter, which is much greater after rains than at other times; or which exists in the largest quantity when the stream rises in a cultivated country. Even in cases when the water used for flooding is pure, and free from animal or vegetable substances, it acts by causing a more equable diffusion of nutritive matter existing in the land; and in very cold seasons it preserves the tender roots and leaves of the grass from being affected by frost. Water is of greater specific gravity at 42° Fahrenheit, than at 32°, the freezing point; and hence, in a meadow irrigated in winter, the water immediately in contact with the grass is rarely below 40°, a degree of temperature not at all prejudicial to the living organs of plants. In 1804, in the month of March, the temperature in a water meadow near Hungerford was examined by a very delicate thermometer. The temperature of the air at seven in the morning was 29°. The water was frozen above the grass. The temperature of the soil below the water in which the roots of the grass were fixed, was 43°." Water may also operate usefully in warm seasons by moderating temperature, and thus retarding the over-rapid progress of vegetation. The consequence of this retardation will be greater magnitude and improved texture of the grosser parts of plants, a more perfect and ample development of their finer parts, and, above all, an increase in the size of their fruits and seeds. We apprehend this to be one of the principal uses of flooding rice-grounds in the East; for it is ascertained that the rice-plant will perfect its seeds in Europe, and even in this country, without any water beyond what is furnished by the weather, and the natural moisture of a well constituted soil. "In general, those waters which breed the best fish are the best fitted for watering meadows; but most of the benefits of irrigation may be derived from any kind of water. It is, however, a general principle, that waters containing ferruginous impregnation, though possessed of fertilising effects when applied to a calcareous soil, are injurious on soils that do not effervesce with acids; and that calcareous waters, which are known by the earthy deposit they afford when boiled, are of most use on siliceous soils, or other soils containing no remarkable quantity of carbonate of lime."

SUBJECT. 6. *Changing the Condition of Lands, in respect to Atmospherical Influence.*

2150. *The influence of the weather on soils* may be affected by changing the position of their surface and by sheltering or shading.

2151. *Changing the condition of lands, as to solar influence*, is but a limited means of improvement; but is capable of being turned to some account in gardening. It is effected by altering the position of their surface, so as that surface may be more or less at right angles to the plane of the sun's rays, according as heat or cold is to be increased or diminished. The influence of the sun's rays upon any plane are demonstrated to be as their number and perpendicularity to that plane, neglecting the effects of the atmosphere. Hence one advantage of ridging lands, provided the ridges run north and south; for on such surfaces the rays of the morning sun will take effect sooner on the east side, and those of the afternoon will remain longer in operation on the west side; whilst at mid-day his elevation will compensate, in some degree, for the obliquity of his rays to both sides of the ridge. In culture, on a small scale, ridges or sloping beds for winter-crops may be made south-east and north-west, with their slope to the south, at an angle of forty degrees, and as steep on the north side as the mass can be got to stand; and on the south slope of such ridge, *ceteris paribus*, it is evident much earlier crops may be produced than on level ground. The north side, however, will be lost during this early cropping; but as early crops are soon gathered, the whole can be laid level in time for a main crop. Hence all the advantage of grounds sloping to the south south-east, or south-west, in point of precocity, and of those sloping to the north for lateness and diminished evaporation. Another advantage of such surfaces is, that they dry sooner after rains, whether by the operation of natural or artificial drainage; or in the case of sloping to the south, by evaporation.

2152. *Shelter*, whether by walls, hedges, strips of plantation, or trees scattered over the surface, may be considered generally, as increasing or preserving heat, and lessening evaporation from the soil. But if the current of air should be of a higher temperature than that of the earth, screens against wind will prevent the earth from being so soon heated; and from the increased evaporation arising from so great a multiplication of vegetable surface by the trees, more cold will be produced after rains, and the atmosphere kept in a more moist state, than in grounds perfectly naked. When the temperature of a current of air is lower than that of the earth, screens will prevent its carrying off so much heat; but more especially scattered trees, the tops of which will be chiefly cooled whilst the under surfaces of their lower branches reflect back the rays of heat as they radiate from the surface of the soil. Heat in its transmission from one body to another, follows the same laws as light; and, therefore, the temperature of the surface in a forest

will, in winter, be considerably higher than that of a similarly constituted soil exposed to the full influence of the weather. The early flowering of plants, in woods and hedges, is a proof of this: but as such soils cannot be so easily heated in summer, and are cooled like others after the sinking in of rains, or the melting of snows, the effect of the reflection as to the whole year is nearly neutralised, and the average temperature of the year of such soils and situations will probably be found not greater than that of open lands.

2153. *Shading* the ground, whether by umbrageous trees, spreading plants, or covering it with tiles, slates, moss, litter, &c. has a tendency to exclude atmospherical heat and retain moisture. Shading dry loose soils, by covering them with litter, or slates, or tiles, laid round the roots of plants, is found very beneficial.

#### SUBJECT. 7. *Rotation of Crops.*

2154. *Growing different crops in succession* is a practice which every cultivator knows to be highly advantageous, though its beneficial influence has not yet been fully accounted for by chemists. The most general theory is, that though all plants will live on the same food, as the chemical constituents of their roots and leaves are nearly the same, yet that many species require particular substances to bring their seeds or fruits to perfection, as the analysis of these seeds or fruits often afford substances different from those which constitute the body of the plant. A sort of rotation may be said to take place in nature, for perennial herbaceous plants have a tendency to extend their circumference, and rot and decay at their centre, where others of a different kind spring up and succeed them. This is more especially the case with travelling roots, as in mint, strawberry, creeping crowfoot, &c.

2155. *The rationale of rotation*, is thus given by Sir H. Davy. "It is a great advantage in the convertible system of cultivation, that the whole of the manure is employed; and that those parts of it which are not fitted for one crop, remain as nourishment for another. Thus, if the turnip is the first in the order of succession, this crop, manured with recent dung, immediately finds sufficient soluble matter for its nourishment; and the heat produced in fermentation assists the germination of the seed and the growth of the plant. If, after turnips, barley with grass-seeds is sown, then the land, having been little exhausted by the turnip crop, affords the soluble parts of the decomposing manure to the grain. The grasses, rye-grass, and clover remain, which derive a small part only of their organised matter from the soil, and probably consume the gypsum in the manure which would be useless to other crops: these plants, likewise, by their large systems of leaves, absorb a considerable quantity of nourishment from the atmosphere; and when ploughed in at the end of two years, the decay of their roots and leaves affords manure for the wheat crop; and at this period of the course, the woody fibre of the farm-yard manure, which contains the phosphate of lime and the other difficultly soluble parts, is broken down: and as soon as the most exhausting crop is taken, recent manure is again applied. Peas and beans, in all instances, seem well adapted to prepare ground for wheat; and in some rich lands they are raised in alternate crops for years together. Peas and beans contain a small quantity of a matter analogous to albumen; but it seems that the azote, which forms a constituent part of this matter, is derived from the atmosphere. The dry bean-leaf, when burnt, yields a smell approaching to that of decomposing animal matter; and in its decay in the soil, may furnish principles capable of becoming a part of the gluten in wheat. Though the general composition of plants is very analogous, yet the specific difference in the products of many of them, prove that they must derive different materials from the soil; and though the vegetables having the smallest system of leaves will proportionably most exhaust the soil of common nutritive matter, yet particular vegetables, when their produce is carried off, will require peculiar principles to be supplied to the land in which they grow. Strawberries and potatoes at first produce luxuriantly in virgin mould, recently turned up from pasture; but in a few years they degenerate, and require a fresh soil. Lands, in a course of years, often cease to afford good cultivated grasses; they become (as it is popularly said) tired of them; and one of the probable reasons for this is, the exhaustion of the gypsum contained in the soil."

2156. *The powers of vegetables to exhaust the soil of the principles necessary to their growth*, is remarkably exemplified in certain *funguses*. Mushrooms are said never to rise in two successive seasons on the same spot; and the production of the phenomena called fairy rings has been ascribed by Dr. Wollaston to the power of the peculiar fungus which forms it, to exhaust the soil of the nutriment necessary for the growth of the species. The consequence is, that the ring annually extends; for no seeds will grow where their parents grew before them, and the interior part of the circle has been exhausted by preceding crops; but where the fungus has died, nourishment is supplied for grass, which usually rises within the circle, coarse, and of a dark green color.

2157. *A rotation is unnecessary, according to Grisenthwaite*; and, in a strict chemical sense, what he asserts cannot be denied. His theory is a refinement on the common

idea of the uses of a rotation stated above; but by giving some details of the constituent parts of certain grains and certain manures, he has presented it in a more clear and striking point of view than has hitherto been done. To apply the theory in every case, the constituent parts of all manures and of all plants (1st, their roots and leaves, and 2dly, their seeds, fruits, or grains,) must be known. In respect to manures this is the case, and it may be said to be in a great degree the case as to the most useful agricultural plants; but, unfortunately for our purpose, the same cannot be said of garden productions in general, though no branch of culture can show the advantage of a rotation of crops more than horticulture, in the practice of which it is found that grounds become tired of particular crops, notwithstanding that manures are applied at pleasure. If the precise effects of a rotation were ascertained, and the ingredients peculiarly necessary to every species pointed out, nothing could be more interesting than the results of experimental trials; and whoever shall point out a simple and economical mode by which the potatoe may be grown successively in the same soil, and produce annually, neglecting the effects of climate, as dry and well-flavored tubers, or nearly so, as they generally produce the first and second years on a new soil, will confer a real benefit on society. That wheat may be grown many years on the same soil by the use of animal manures, or such as contain gluten, Grisenthwaite's theory would justify us in believing chemically; and it ought to be fairly tried by such cultivators as Coke and Curwen. Till this is done in the face of the whole agricultural world, and the produce of every crop, and all the particulars of its culture, accurately reported on annually, the possibility of the thing may be assented to from the premises, but will not be acted on; and, in fact, even the best agricultural chemists do not consider that we are sufficiently advanced in that branch of the science to draw any conclusion, *à priori*, very much at variance with general opinion and experience. It should always be kept in mind, that it is one thing to produce a crop, and a different thing to grow crops with profit.

2158. *The principles of rotations of crops*, are thus laid down by Yvart and Ch. Pictet (*Cours complet d'Agriculture*, articles *Assolement*, and *Succession de Culture*; and *Traité des Assolemens*. Paris, 8vo.

The first principle, or fundamental point is, that every plant exhausts the soil.

The second, that all plants do not exhaust the soil equally.

The third, that plants of different kinds do not exhaust the soil in the same manner.

The fourth, that all plants do not restore to the soil the same quantity, nor the same quality of manure.

The fifth, that all plants are not equally favorable to the growth of weeds.

2159. *The following consequences* are drawn, from these fundamental principles:

*First.* However well a soil may be prepared, it cannot long nourish crops of the same kind in succession, without becoming exhausted.

*Second.* Every crop impoverishes a soil more or less, according as more or less is restored to the soil by the plant cultivated.

*Third.* Perpendicular rooting plants, and such as root horizontally, ought to succeed each other.

*Fourth.* Plants of the same kind should not return too frequently in a rotation.

*Fifth.* Two plants favorable to the growth of weeds, ought not to succeed each other.

*Sixth.* Such plants as eminently exhaust the soil, as the grains and oil plants, should only be sown when the land is in good heart.

*Seventh.* In proportion as a soil is found to exhaust itself by successive crops, plants which are least exhausting ought to be cultivated.

2160. *Influence of rotations in destroying insects.* Olivier, member of the Institute of France, has described all the insects, chiefly tipulæ and muscæ, which live upon the collar or crown of the roots of the cereal grasses, and he has shewn that they multiply themselves without end, when the same soil presents the same crop for several years in succession, or even crops of analogous species. But when a crop intervenes on which these insects cannot live, as beans or turnips, after wheat or oats, then the whole race of these insects perish from the field, for want of proper nourishment for their larva. (*Mem. de la Société Royale et Centrale d'Agr. de Paris*, vol. vii.)

---

## CHAP. II.

### *Of Manures.*

2161. *Every species of matter capable of promoting the growth of vegetables* may be considered as manure. On examining the constituents of vegetables, we shall find that they are composed of oxygen, hydrogen, carbon, and nitrogen, or azote, with a small proportion of saline bodies. It is evident, therefore, that the substances employed as manure should also be composed of these elements, for unless they are, there will be a deficiency in some of the elements in the vegetable itself; and it is probable that such deficiency may prevent the formation of those substances within it, for which its

peculiar organisation is contrived, and upon which its healthy existence depends. The elementary bodies above enumerated are all contained in animal, and the three first in vegetable matters. Sometimes vegetables, though very seldom, contain a small quantity of nitrogen. As certain salts are also constantly found to be present in healthy living vegetables, manures or vegetable food may, consequently, be distinguished into animal, vegetable, and saline. The authors whom we have already mentioned (2065.) as producing the first chemical treatises on soils, were also the first to treat chemically of manures. Of these, the latest in the order of time is Sir H. Davy, from whose highly satisfactory work we shall extract the greater part of this chapter.

SECT. I. *Of Manures of Animal and Vegetable Origin.*

2162. *Decaying animal and vegetable substances* constitute by far the most important class of manures, or vegetable food, and may be considered as to the theory of their operation, their specific kinds, and their preservation and application in practice.

SUBJECT. 1. *The Theory of the Operation of Manures of Animal and Vegetable Origin.*

2163. *The rationale of organic manures* is very satisfactorily given by Sir H. Davy, who, after having proved that no solid substances can enter in that state into the plant, explains the manner in which nourishment is derived from vegetable and animal substances.

2164. *Vegetable and animal substances deposited in the soil*, as is shown by universal experience, are consumed during the process of vegetation; and they can only nourish the plant by affording solid matters capable of being dissolved by water, or gaseous substances capable of being absorbed by the fluids in the leaves of vegetables; but such parts of them as are rendered gaseous, and pass into the atmosphere, must produce a comparatively small effect, for gases soon become diffused through the mass of the surrounding air. The great object, therefore, in the application of manure should be to make it afford as much soluble matter as possible to the roots of the plant; and that in a slow and gradual manner, so that it may be entirely consumed in forming its sap and organised parts.

2165. *Mucilaginous, gelatinous, saccharine, oily, and extractive fluids, carbonic acid, and water*, are substances that in their unchanged states contain almost all the principles necessary for the life of plants; but there are few cases in which they can be applied as manures in their pure forms; and vegetable manures, in general, contain a great excess of fibrous and insoluble matter, which must undergo chemical changes before they can become the food of plants.

2166. *The nature of the changes on these substances; of the causes which occasion them, and which accelerate or retard them; and of the products they afford*, have been scientifically stated and explained by our great agricultural chemist. If any fresh vegetable matter which contains sugar, mucilage, starch, or other of the vegetable compounds soluble in water, be moistened, and exposed to air, at a temperature from 55° to 80°, oxygen will soon be absorbed, and carbonic acid formed; heat will be produced, and elastic fluids, principally carbonic acid, gaseous oxide of carbon, and hydro-carbonate will be evolved; a dark-colored liquid, of a slightly sour or bitter taste, will likewise be formed; and if the process be suffered to continue for a time sufficiently long, nothing solid will remain, except earthy and saline matter, colored black by charcoal. The dark-colored fluid formed in the fermentation always contains acetic acid; and when albumen or gluten exists in the vegetable substance, it likewise contains volatile alkali. In proportion as there is more gluten, albumen, or matters soluble in water, in the vegetable substances exposed to fermentation, so in proportion, all other circumstances being equal, will the process be more rapid. Pure woody fibre alone undergoes a change very slowly; but its texture is broken down, and it is easily resolved into new aliments, when mixed with substances more liable to change, containing more oxygen and hydrogen. Volatile and fixed oils, resins, and wax, are more susceptible of change than woody fibre, when exposed to air and water; but much less liable than the other vegetable compounds; and even the most inflammable substances, by the absorption of oxygen, become gradually soluble in water. Animal matters in general are more liable to decompose than vegetable substances; oxygen is absorbed and carbonic acid and ammonia formed in the process of their putrefaction. They produce fetid, compound, elastic fluids and likewise azote: they afford dark-colored acid and oily fluids, and leave a residuum of salts and earths mixed with carbonaceous matter.

2167. *The principal animal substances which constitute their different parts, or which are found in their blood, their secretions, or their excrements*, are gelatine, fibrine, mucus, fatty, or oily matter, albumen, urea, uric acid, and different other acid, saline, and earthy matters.

2168. *General treatment of organic manures.* Whenever manures consist principally of matter soluble in water, it is evident that their fermentation or putrefaction should be

prevented as much as possible; and the only cases in which these processes can be useful, are when the manure consists principally of vegetable or animal fibre. The circumstances necessary for the putrefaction of animal substances are similar to those required for the fermentation of vegetable substances; a temperature above the freezing point, the presence of water, and the presence of oxygen, at least in the first stage of the process. To prevent manures from decomposing, they should be preserved dry, defended from the contact of air, and kept as cool as possible. Salt and alcohol appear to owe their powers of preserving animal and vegetable substances to their attraction for water, by which they prevent its decomposing action, and likewise to their excluding air.

SUBJECT. 2. *Of the different Species of Manures of Animal and Vegetable Origin.*

2169. *The properties and nature of the manures in common use* should be known to every cultivator: for as different manures contain different proportions of the elements necessary to vegetation, so they require a different treatment to enable them to produce their full effects in culture.

2170. *All green succulent plants* contain saccharine or mucilaginous matter, with woody fibre, and readily ferment. They cannot, therefore, if intended for manure, be used too soon after their death. Hence the advantage of digging or ploughing in green crops, whether natural, of weeds, or sown on purpose; they must not, however, be turned in too deep, otherwise, as Mrs. Ibbetson has shown (*Philos. Mag.* 1816), fermentation will be prevented by compression and exclusion of air. Green crops should be ploughed in, if it be possible, when in flower, or at the time the flower is beginning to appear, for it is at this period that they contain the largest quantity of easily soluble matter, and that their leaves are most active in forming nutritive matter. Green crops, pond-weeds, the paring of hedges or ditches, or any kind of fresh vegetable matter, require no preparation to fit them for manure. The decomposition slowly proceeds beneath the soil; the soluble matters are gradually dissolved, and the slight fermentation that goes on, checked by the want of a free communication of air, tends to render the woody fibre soluble without occasioning the rapid dissipation of elastic matter. When old pastures are broken up and made arable, not only has the soil been enriched by the death and slow decay of the plants which have left soluble matters in the soil, but the leaves and roots of the grasses, living at the time, and occupying so large a part of the surface, afford saccharine, mucilaginous, and extractive matters, which become immediately the food of the crop, and the gradual decomposition affords a supply for successive years.

2171. *Rape-cake*, which is used with great success as manure, contains a large quantity of mucilage, some albuminous matter, and a small quantity of oil. This manure should be used recent, and kept as dry as possible before it is applied. It forms an excellent dressing for turnip crops; and is most economically applied by being thrown into the soil at the same time with the seed.

2172. *Malt-dust* consists chiefly of the infant radicle separated from the grain. Sir H. Davy never made any experiment upon this manure; but has great reason to suppose it must contain saccharine matter, and this will account for its powerful effects. Like rape-cake, it should be used as dry as possible, and its fermentation prevented.

2173. *Linseed-cake* is too valuable as a food for cattle to be much employed as a manure. The water in which flax and hemp are steeped, for the purpose of obtaining the pure vegetable fibre, has considerable fertilising powers. It appears to contain a substance analogous to albumen, and likewise much vegetable extractive matter. It putrefies very readily. By the watering process, a certain degree of fermentation is absolutely necessary to obtain the flax and hemp in a proper state; the water to which they have been exposed should therefore be used as a manure as soon as the vegetable fibre is removed from it. Washing with soap has been successfully substituted for watering by lie.

2174. *Sea-weeds*, consisting of different species of fuci, algæ, and confervæ, are much used as a manure on the sea-coasts of Britain and Ireland. By digesting the common fucus, which is the sea-weed usually most abundant on the coast, in boiling water, one-eighth of a gelatinous substance will be obtained, with characters similar to mucilage. A quantity distilled gave nearly four fifths of its weight of water, but no ammonia; the water had an empyreumatic and slightly sour taste; the ashes contained sea-salt, carbonate of soda, and carbonaceous matter. The gaseous matter afforded was small in quantity, principally carbonic acid, and gaseous oxide of carbon, with a little hydro-carbonate. This manure is transient in its effects, and does not last for more than a single crop; which is easily accounted for from the large quantity of water, or the elements of water, it contains. It decays without producing heat when exposed to the atmosphere, and seems, as it were, to melt down and dissolve away. A large heap has been entirely destroyed in less than two years, nothing remaining but a little black fibrous matter. Some of the firmest part of a fucus were suffered to remain in a close jar, containing atmospheric air for a fortnight: in this time it had become very much shrivelled; the sides

of the jar were lined with dew. The air examined was found to have lost oxygen, and contained carbonic acid gas. Sea-weed is sometimes suffered to cement before it is used; but this process seems wholly unnecessary, for there is no fibrous matter rendered soluble in the process, and a part of the manure is lost. The best cultivators use it as fresh as it can be procured; and the practical results of this mode of applying it are exactly conformable to the theory of its operation. The carbonic acid formed by its incipient fermentation must be partly dissolved by the water set free in the same process; and thus become capable of absorption by the roots of plants. The effects of the seaweed, as manure, must principally depend upon this carbonic acid, and upon the soluble mucilage the weed contains; some fucus which had fermented so as to have lost about half its weight, afforded less than one-twelfth of mucilaginous matter; from which it may be fairly concluded that some of this substance is destroyed in fermentation.

2175. *Dry straw* of wheat, oats, barley, beans, and peas, and spoiled hay, or any other similar kind of dry vegetable matter, is, in all cases, useful manure. In general, such substances are made to ferment before they are employed, though it may be doubted whether the practice should be indiscriminately adopted. From 400 grains of dry barley-straw eight grains of matter soluble in water were obtained, which had a brown color, and tasted like mucilage. From 400 grains of wheat straw, were obtained five grains of a similar substance. There can be no doubt that the straw of different crops, immediately ploughed into the ground, affords nourishment to plants; but there is an objection to this method of using straw, from the difficulty of burying long straw, and from its rendering the husbandry foul. When straw is made to ferment, it becomes a more manageable manure; but there is likewise, on the whole, a great loss of nutritive matter. More manure is perhaps supplied for a single crop; but the land is less improved than it would be, supposing the whole of the vegetable matter could be finally divided and mixed with the soil. It is usual to carry straw that can be employed for no other purpose to the dunghill, to ferment, and decompose; but it is worth experiment, whether it may not be more economically applied when chopped small by a proper machine, and kept dry till it is ploughed in for the use of a crop. In this case, though it would decompose much more slowly, and produce less effect at first, yet its influence would be much more lasting.

2176. *Mere woody fibre* seems to be the only vegetable matter that requires fermentation to render it nutritive to plants. Tanners' spent bark is a substance of this kind. A. Young, in his excellent *Essay on Manure*, states, "that spent bark seemed rather to injure than assist vegetation;" which he attributes to the astringent matter that it contains. But, in fact, it is freed from all soluble substances, by the operation of water in the tanpit; and if injurious to vegetation, the effect is probably owing to its agency upon water, or to its mechanical effects. It is a substance very absorbent and retentive of moisture, and yet not penetrable by the roots of plants.

2177. *Inert peaty matter* is a substance of the same kind. It remains for years exposed to water and air without undergoing change, and in this state yields little or no nourishment to plants. Woody fibre will not ferment, unless some substances are mixed with it, which act the same part as the mucilage, sugar, and extractive or albuminous matters, with which it is usually associated in herbs and succulent vegetables. Lord Meadowbank has judiciously recommended a mixture of common farm-yard dung for the purpose of bringing peat into fermentation: any putrescible or fermentable substance will answer the end; and the more a substance heats, and the more readily it ferments, the better will it be fitted for the purpose. Lord Meadowbank states, that one part of dung is sufficient to bring three or four parts of peat into a state in which it is fitted to be applied to land; but of course the quantity must vary according to the nature of the dung and of the peat. In cases in which some living vegetables are mixed with the peat, the fermentation will be more readily effected.

2178. *Tanners' spent bark*, shavings of wood, and saw-dust will probably require as much dung to bring them into fermentation as the worst kind of peat. Woody fibre may be likewise prepared, so as to become a manure, by the action of life. It is evident, from the analysis of woody fibre by Gay Lussac and Thenard (which shows that it consists principally of the elements of water and carbon, the carbon being in larger quantities than in the other vegetable compounds), that any process which tends to abstract carbonaceous matter from it, must bring it nearer in composition to the soluble principles; and this is done in fermentation by the absorption of oxygen and production of carbonic acid; and a similar effect, it will be shown, is produced by lime.

2179. *Wood-ashes*, imperfectly formed, that is, wood-ashes containing much charcoal, are said to have been used with success as a manure. A part of their effects may be owing to the slow and gradual consumption of the charcoal, which seems capable, under other circumstances than those of actual combustion, of absorbing oxygen so as to become carbonic acid. In April 1803, some well-burnt charcoal was enclosed by Sir H. Davy, in a tube, half filled with pure water, and half with common air; the tube was hermetically sealed. The tube was opened under pure water, in the spring of 1804, at a time when

the atmospheric temperature and pressure were nearly the same as at the commencement of the experiment. Some water rushed in; and on expelling a little air by heat from the tube, and analysing it, it was found to contain only seven per cent. of oxygen. The water in the tube, when mixed with lime-water, produced a copious precipitate; so that carbonic acid had evidently been formed and dissolved by the water.

2180. *Manures from animal substances*, in general, require no chemical preparation to fit them for the soil. The great object of the farmer is to blend them with the earthy constituents in a proper state of division, and to prevent their too rapid decomposition.

2181. *The entire parts of the muscles of land animals* are not commonly used as manure, though there are many cases in which such an application might be easily made. Horses, dogs, sheep, deer, and other quadrupeds that have died accidentally, or of disease, after their skins are separated, are often suffered to remain exposed to the air, or immersed in water, till they are destroyed by birds or beasts of prey, or entirely decomposed; and in this case, most of their organised matter is lost for the land in which they lie, and a considerable portion of it employed in giving off noxious gases to the atmosphere. By covering dead animals with five or six times their bulk of soil, mixed with one part of lime, and suffering them to remain for a few months; their decomposition would impregnate the soil with soluble matters, so as to render it an excellent manure; and by mixing a little fresh quick-lime with it at the time of its removal, the disagreeable effluvia would be in a great measure destroyed; and it might be applied in the same way as any other manure to crops.

2182. *Fish* forms a powerful manure, in whatever state it is applied; but it cannot be ploughed in too fresh, though the quantity should be limited. A. Young records an experiment, in which herrings spread over a field, and ploughed in for wheat, produced so rank a crop, that it was entirely laid before harvest. The refuse pilchards in Cornwall are used throughout the county as a manure, with excellent effects. They are usually mixed with sand or soil, and sometimes with sea-weed, to prevent them from raising too luxuriant a crop. The effects are perceived for several years. In the fens of Lincolnshire, Cambridgeshire, and Norfolk, the little fishes called sticklebacks, are caught in the shallow waters in such quantities, that they form a great article of manure in the land bordering on the fens. It is easy to explain the operation of fish as a manure. The skin is principally gelatine; which, from its slight state of cohesion, is readily soluble in water: fat or oil is always found in fishes, either under the skin or in some of the viscera; and their fibrous matter contains all the essential elements of vegetable substances.

2183. Amongst *oily substances*, blubber has been employed as a manure. It is most useful when mixed with clay, sand, or any common soil, so as to expose a large surface to the air, the oxygen of which produces soluble matter from it. Lord Somerville used blubber with great success at his farm in Surrey. It was made into a heap with soil, and retained its powers of fertilising for several successive years. The carbon and hydrogen abounding in oily substances, fully account for their effects; and their durability is easily explained from the gradual manner in which they change by the action of air and water.

2184. *Bones* are much used as a manure in the neighborhood of London. After being broken, and boiled for grease, they are sold to the farmer. The more divided they are, the more powerful are their effects. The expense of grinding them in a mill would probably be repaid by the increase of their fertilising powers; and in the state of powder they might be used in the drill husbandry, and delivered with the seed, in the same manner as rape-cake. Bone-dust and bone-shavings, the refuse of the turning manufacture, may be advantageously employed in the same way. The basis of bone is constituted by earthy salts, principally phosphate of lime, with some carbonate of lime and phosphate of magnesia; the easily decomposable substances in bone, are fat, gelatine, and cartilage, which seems of the same nature as coagulated albumen. According to the analysis of Fourcroy and Vauquelin, ox-bones are composed of decomposable animal matter 51; phosphate of lime 37·7, carbonate of lime 10, phosphate of magnesia 1·3; — total 100.

2185. *Horn* is a still more powerful manure than bone, as it contains a larger quantity of decomposable animal matter. From 500 grains of ox-horn, Hatchett obtained only 1·5 grains of earthy residuum, and not quite half of this was phosphate of lime. The shavings or turnings of horn form an excellent manure, though they are not sufficiently abundant to be in common use. The animal matter in them seems to be of the nature of coagulated albumen, and it is slowly rendered soluble by the action of water. The earthy matter in horn, and still more that in bones, prevents the too rapid decomposition of the animal matter, and renders it very durable in its effects.

2186. *Hair, woollen rags, and feathers*, are all analogous in composition, and principally consist of a substance similar to albumen united to gelatine. This is shown by the

ingenious researches of Hatchett. The theory of their operation is similar to that of bone and horn shavings.

2187. *The refuse of the different manufactures of skin and leather* form very useful manures; such as the shavings of the currier, furriers' clippings, and the offals of the tan-yard and of the glue-maker. The gelatine contained in every kind of skin is in a state fitted for its gradual solution or decomposition; and when buried in the soil, it lasts for a considerable time, and constantly affords a supply of nutritive matter to the plants in its neighborhood.

2188. *Blood* contains certain quantities of all the principles found in other animal substances, and is consequently a very good manure. It has been already stated that it contains fibrine; it likewise contains albumen; the red particles in it, which have been supposed by many foreign chemists to be coloured by iron in a particular state of combination with oxygen and acid matter, Brande considers as formed of a peculiar animal substance containing very little iron. The scum taken from the boilers of the sugar-bakers, and which is used as manure, principally consists of bullocks' blood, which has been employed for the purpose of separating the impurities of common brown sugar, by means of the coagulation of its albuminous matter by the heat of the boiler.

2189. *The different species of corals, corallines, and sponges*, must be considered as substances of animal origin. From the analysis of Hatchett, it appears that all these substances contain considerable quantities of a matter analogous to coagulated albumen; the sponges afford likewise gelatine. According to Merat Guillot, white coral contains equal parts of animal matter and carbonate of lime; red coral 46.5 of animal matter, and 53.5 of carbonate of lime; articulated coralline 51 of animal matter, and 49 of carbonate of lime. These substances are never used as manure in this country, except in cases when they are accidentally mixed with sea-weed; but it is probable that the corallines might be advantageously employed, as they are found in considerable quantity on the rocks, and bottoms of the rocky pools on many parts of our coast, where the land gradually declines towards the sea; and they might be detached by hoes, and collected without much trouble.

2190. Amongst *excrementitious animal substances* used as manures, urine is the one upon which the greatest number of chemical experiments have been made, and the nature of which is best understood. The urine of the cow contains, according to the experiments of Brande: water 65; phosphate of lime 3; muriates of potassa and ammonia 15; sulphate of potassa 6; carbonates, potassa, and ammonia 4; urea 4.

2191. *The urine of the horse*, according to Fourcroy and Vauquelin, contains, of carbonate of lime 11, carbonate of soda 9, benzoate of soda 24, muriate of potassa 9, urea 7, water and mucilage 940. In addition to these substances, Brande found in it phosphate of lime. The urine of the ass, the camel, the rabbit, and domestic fowls, have been submitted to different experiments, and their constitution have been found similar. In the urine of the rabbit, in addition to most of the ingredients above mentioned, Vauquelin detected gelatine; and the same chemist discovered uric acid in the urine of domestic fowls. Human urine contains a greater variety of constituents than any other species examined. Urea, uric acid, and another acid similar to it in nature, called rosacic acid, acetic acid, albumen, gelatine, a resinous matter, and various salts are found in it. The human urine differs in composition, according to the state of the body, and the nature of the food and drink made use of. In many cases of disease there is a much larger quantity of gelatine and albumen than usual in the urine; and in diabetes it contains sugar. It is probable that the urine of the same animal must likewise differ according to the different nature of the food and drink used; and this will account for discordances in some of the analysis that have been published on the subject. Urine is very liable to change, and to undergo the putrefactive process; and that of carnivorous animals more rapidly than that of graminivorous animals. In proportion as there is more gelatine or albumen in urine, so in proportion does it putrefy more quickly. The species of urine that contains most albumen, gelatine, and urea, are the best as manures; and all urine contains the essential elements of vegetables in a state of solution. During the putrefaction of urine the greatest part of the soluble animal matter that it contains is destroyed: it should consequently be used as fresh as possible; but if not mixed with solid matter, it should be diluted with water, as, when pure, it contains too large a quantity of animal matter to form a proper fluid nourishment for absorption by the roots of plants.

2192. *Putrid urine* abounds in ammoniacal salts; and though less active than fresh urine, is a very powerful manure. According to a recent analysis published by Berzelius, 1000 parts of urine are composed of, water 933; urea 30.1; uric acid 1; muriate of ammonia, free lactic acid, lactate of ammonia, and animal matter 17.14. The remainder different salts, phosphates, sulphates, and muriates.

2193. *Dung of birds*. Amongst excrementitious solid substances used as manures, one of the most powerful is the dung of birds that feed on animal food, particularly the dung of



sea-birds. The guano, which is used to a great extent in South America, and which is the manure that fertilizes the sterile plains of Peru, is a production of this kind. It exists abundantly, as we are informed by Humboldt, on the small islands in the South Sea, at Chinche, Ilo, Iza, and Arica. Fifty vessels are laden with it annually at Chinche, each of which carries from 1500 to 2000 cubical feet. It is used as a manure only in very small quantities; and particularly for crops of maize. Some experiments were made on specimens of guano in 1805. It appeared as a fine brown powder; it blackened by heat, and gave off strong ammoniacal fumes; treated with nitric acid, it afforded uric acid. In 1806, Fourcroy and Vauquelin published an elaborate analysis of guano. They state that it contains a fourth part of its weight of uric acid, partly saturated with ammonia, and partly with potassa; some phosphoric acid combined with the bases, and likewise with lime. Small quantities of sulphate and muriate of potassa, a little fatty matter, and some quartzose sand. It is easy to explain its fertilizing properties: from its composition it might be supposed to be a very powerful manure. It requires water for the solution of its soluble matter to enable it to produce its full beneficial effect on crops.

2194. *The dung of sea-birds* has never been much used as a manure in this country; but it is probable that even the soil of the small islands on our coast much frequented by them would fertilise. Some dung of sea-birds, brought from a rock on the coast of Merionethshire, produced a powerful, but transient effect on grass. The rains in our climate must tend very much to injure this species of manure, where it is exposed to them, soon after its deposition; but it may probably be found in great perfection in caverns or clefts in rocks haunted by cormorants and gulls. Some recent cormorants' dung, when examined, had not at all the appearance of guano; it was of a greyish-white colour; had a very fetid smell, like that of putrid animal matter; when acted on by quick-lime, it gave abundance of ammonia; treated with nitric acid, it yielded uric acid.

2195. *Night soil*, it is well known, is a very powerful manure, and very liable to decompose. It differs in composition; but always abounds in substances composed of carbon, hydrogen, azote, and oxygen. From the analysis of Berzelius, it appears that a part of it is always soluble in water; and in whatever state it is used, whether recent or fermented, it supplies abundance of food to plants. The disagreeable smell of night-soil may be destroyed by mixing it with quick-lime; and if exposed to the atmosphere in thin layers, strewed over with quick-lime in fine weather, it speedily dries, is easily pulverised, and in this state, may be used in the same manner as rape-cake, and delivered into the furrow with the seed. The Chinese, who have more practical knowledge of the use and application of manures than any other people existing, mix their night-soil with one third of its weight of fat marl, make it into cakes, and dry it by exposure to the sun. These cakes, we are informed by the French missionaries, have no disagreeable smell, and form a common article of commerce of the empire. The earth, by its absorbent powers, probably prevents, to a certain extent, the action of moisture upon the dung, and likewise defends it from the effects of air. Desiccated night-soil, in a state of powder, forms an article of internal commerce in France, and is known under the name of *poudrette*. In London it is mixed with quick-lime, and sold in cakes under the name of "desiccated night-soil."

2196. *Pigeons' dung* comes next in order, as to fertilising power. 100 grains digested in hot water for some hours, produced 23 grains of soluble matter, which afforded abundance of carbonate of ammonia by distillation; and left carbonaceous matter, saline matter, principally common salt, and carbonate of lime as a residuum. Pigeons' dung, when moist, readily ferments, and after fermentation, contains less soluble matter than before; from 100 parts of fermented pigeons' dung, only eight parts of soluble matter were obtained, which gave proportionably less carbonate of ammonia in distillation than recent pigeons' dung. It is evident that this manure should be applied as new as possible; and when dry, it may be employed in the same manner as the other manures capable of being pulverised. The soil in woods, where great flocks of wood-pigeons roost, is often highly impregnated with their dung, and it cannot be doubted, would form a valuable manure. Such soil will often yield ammonia when distilled with lime. In the winter, likewise, it usually contains abundance of vegetable matter, the remains of decayed leaves, and the dung tends to bring the vegetable matter into a state of solution. Manuring was, and still is, in great esteem in Persia.

2197. *The dung of domestic fowls* approaches very nearly in its nature to pigeons' dung. Uric acid has been found in it. It gives carbonate of ammonia by distillation, and immediately yields soluble matter to water. It is very liable to ferment. The dung of fowls is employed, in common with that of pigeons, by tanners, to bring on a slight degree of putrefaction in skins that are to be used for making soft leather; for this purpose the dung is diffused through water. In this state it rapidly undergoes putrefaction, and brings on a similar change in the skin. The excrements of dogs are employed by the tanner with similar effects. In all cases, the contents of the *grainer*, as the pit is called in which soft skins are prepared by dung, must form a very useful manure.

12198. *Rabbits' dung* has never been analysed. It is used with great success as a manure by some farmers, who find it profitable to keep rabbits in such a manner as to preserve their dung. It is laid on as fresh as possible, and is found better the less it has fermented.

12199. *The dung of cattle, oxen, and cows*, has been chemically examined by Einhof and Thaer. They found that it contained matter soluble in water; and that it gave in fermentation nearly the same products as vegetable substances, absorbing oxygen, and producing carbonic acid gas.

12200. *The recent dung of sheep and of deer* affords, when long boiled in water, soluble matters which equal from two to three per cent. of their weight. These soluble substances, procured by solution and evaporation, when examined, contain a very small quantity of matter analogous to animal mucus; and are principally composed of a bitter extract, soluble both in water and in alcohol. They give ammoniacal fumes by distillation, and appear to differ very little in composition. Some blades of grass were watered for several successive days with a solution of these extracts; they evidently became greener in consequence, and grew more vigorously than grass in other respects under the same circumstances. The part of the dung of cattle, sheep, and deer, not soluble in water, appears to be mere woody fibre, and precisely analogous to the residuum of those vegetables that form their food after they have been deprived of all their soluble materials.

12201. *The dung of horses* gives a brown fluid, which, when evaporated, yields a bitter extract, which affords ammoniacal fumes more copiously than that from the dung of oxen.

12202. *In the treatment of the pure dung of cattle, sheep, and horses*, there seems no reason why it should be made to ferment except in the soil, like the other pure dungs; or, if suffered to ferment, it should be only in a very slight degree. The grass, in the neighborhood of recently voided dung, is always coarse and dark green; some persons have attributed this to a noxious quality in unfermenting dung; but it seems to be rather the result of an excess of food furnished to the plants.

12203. *Street and road dung and the sweepings of houses* may be all regarded as composite manures; the constitution of them is necessarily various, as they are derived from a number of different substances. These manures are usually applied in a proper manner, without being fermented.

12204. *Soot*, which is principally formed from the combustion of pit-coal or coal, generally contains likewise substances derived from animal matters. This is a very powerful manure. It affords ammoniacal salts by distillation, and yields a brown extract to hot water, of a bitter taste. It likewise contains an empyreumatic oil. Its great basis is charcoal, in a state in which it is capable of being rendered soluble by the action of oxygen and water. This manure is well fitted to be used in the dry state, thrown into the ground with the seed, and requires no preparation.

### SUBSECT. 3. *Of the fermenting, preserving, and applying of Manures of Animal and Vegetable Origin.*

12205. *On the management of organic manures* depends much of their value as food to plants. The great mass of manures procured by the cultivator are a mixture of animal and vegetable matters, and the great source of supply is the farm or stable yard. Here the excrementitious matter of horses, cattle, swine, and poultry, is mixed with straw, halm, chaff, and various kinds of litter. To what degree should this be fermented before it is applied to the soil? And how can it best be preserved when not immediately wanted?

12206. *A slight incipient fermentation* is undoubtedly of use in the dunghill; for, by means of it a disposition is brought on in the woody fibre to decay and dissolve, when it is carried to the land, or ploughed into the soil; and woody fibre is always in great excess in the refuse of the farm. Too great a degree of fermentation is, however, very prejudicial to the composite manure in the dunghill: it is better that there should be no fermentation at all before the manure is used, than that it should be carried too far. The excess of fermentation tends to the destruction and dissipation of the most useful part of the manure; and the ultimate results of this process are like those of combustion. It is a common practice amongst farmers to suffer the farm-yard dung to ferment till the fibrous texture of the vegetable matter is entirely broken down; and till the manure becomes perfectly cold, and so soft as to be easily cut by the spade. Independent of the general theoretical views unfavorable to this practice, founded upon the nature and composition of vegetable substances, there are many arguments and facts which show that it is prejudicial to the interests of the farmer.

12207. *During the violent fermentation* which is necessary for reducing farm-yard manure to the state in which it is called shortmuck, not only a large quantity of fluid, but likewise of gaseous matter is lost; so much so, that the dung is reduced one half, or two

thirds in weight; and the principal elastic matter disengaged, is carbonic acid with some ammonia; and both these, if retained by the moisture in the soil, as has been stated before, are capable of becoming a useful nourishment of plants. In October, 1808, Sir H. Davy filled a large retort capable of containing three pints of water, with some hot fermenting manure, consisting principally of the litter and dung of cattle; he adapted a small receiver to the retort, and connected the whole with a mercurial pneumatic apparatus, so as to collect the condensable and elastic fluids which might rise from the dung. The receiver soon became lined with dew, and drops began in a few hours to trickle down the sides of it. Elastic fluid likewise was generated; in three days thirty-five cubical inches had been formed, which, when analysed, were found to contain twenty-one cubical inches of carbonic acid, the remainder was hydrocarbonate mixed with some azote, probably no more than existed in the common air in the receiver. The fluid matter collected in the receiver at the same time amounted to nearly half an ounce. It had a saline taste, and a disagreeable smell, and contained some acetate and carbonate of ammonia. Finding such products given off from fermenting litter, he introduced the beak of another retort, filled with similar dung, very hot at the time, in the soil amongst the roots of some grass in the border of a garden; in less than a week a very distinct effect was produced on the grass; upon the spot exposed to the influence of the matter disengaged in fermentation, it grew with much more luxuriance than the grass in any other part of the garden. — Besides the dissipation of gaseous matter, when fermentation is pushed to the extreme, there is another disadvantage in the loss of heat, which, if excited in the soil, is useful in promoting the germination of the seed, and in assisting the plant in the first stage of its growth, when it is most feeble and most liable to disease: and the fermentation of manure in the soil must be particularly favorable to the wheat crop, in preserving a genial temperature beneath the surface late in autumn and during winter. Again, it is a general principle in chemistry, that in all cases of decomposition, substances combine much more readily at the moment of their disengagement, than after they have been perfectly formed. And in fermentation beneath the soil the fluid matter produced is applied instantly, even whilst it is warm, to the organs of the plant, and consequently is more likely to be efficient, than in manure that has gone through the process; and of which all the principles have entered into new combinations.

2208. *Checking fermentation by covering.* “There are reasons sufficiently strong,” Grisenthwaite observes, “to discourage the practice of allowing dung-heaps to ferment and rot without interruption. It appears that public opinion has slowly adopted the decisions of chemical reasoning, and *dung-pies*, as they are called, have been formed with a view to save what was before lost; a stratum of mould, sustaining the heap, being placed to receive the fluid parts, and a covering of mould being applied to prevent the dissipation of the aerial, or gaseous products. These purposes and contrivances, unfortunately, like many of the other operations of husbandry, were not directed by scientific knowledge. To cover is so commonly believed to confine, that there is no wonder that the practical cultivator adopted it in this instance from such a consideration. But it is in vain; the elasticity of the gases generated is such as no covering whatever could possibly confine. If it were perfectly compact, it could only preserve as much carbonic acid as is equal to the volume or bulk of air within it; a quantity too inconsiderable to be regarded, could it even be saved; but every particle of it must be disengaged, and lost, when the covering is removed.”

2209. *Checking fermentation by watering* is sometimes recommended; but this practice is inconsistent with just chemical views. It may cool the dung for a short time; but moisture, as before stated, is a principal agent in all processes of decomposition. Dry fibrous matter will never ferment. Water is as necessary as air to the process; and to supply it to fermenting dung, is to supply an agent which will hasten its decay. In all cases when dung is fermenting, there are simple tests by which the rapidity of the process, and consequently the injury done, may be discovered. If a thermometer, plunged into the dung, does not rise to above one hundred degrees of Fahrenheit, there is little danger of much æriform matter flying off. If the temperature is higher, the dung should be immediately spread abroad. When a piece of paper, moistened in muriatic acid, held over the steams arising from a dunghill, gives dense fumes, it is a certain test that the decomposition is going too far, for this indicates that volatile alkali is disengaged.

2210. *In favor of the application of farm-yard dung in a recent state*, a great mass of facts may be found in the writings of scientific agriculturists. A. Young, in the *Essay on Manures*, already quoted, adduces a number of excellent authorities in support of the plan. Many, who doubted, have been lately convinced; and perhaps there is no subject of investigation in which there is such a union of theoretical and practical evidence. Within the last seven years Coke has entirely given up the system formerly adopted on his farm, of applying fermented dung; and his crops have been since as good as they ever were, and his manure goes nearly twice as far. A great objection against

slightly fermented dung is, that weeds spring up more luxuriantly where it is applied. If there are seeds carried out in the dung, they certainly will germinate; but it is seldom that this can be the case to any extent; and if the land is not cleansed of weeds, any kind of manure, fermented or unfermented, will occasion their rapid growth. If slightly fermented, farm-yard dung is used as a top-dressing for pastures, the long straws and unfermented vegetable matter remaining on the surface should be removed as soon as the grass begins to rise vigorously, by raking, and carried back to the dunghill: in this case no manure will be lost, and the husbandry will be at once clean and economical. In cases when farm-yard dung cannot be immediately applied to crops, the destructive fermentation of it should be prevented as much as possible: the principles on which this may be effected have been already alluded to. The surface should be defended as much as possible from the oxygen of the atmosphere; a compact marl, or a tenacious clay, offers the best protection against the air; and before the dung is covered over, or, as it were, sealed up, it should be dried as much as possible. If the dung is found at any time to heat strongly, it should be turned over, and cooled by exposure to the air.

2211. The doctrine of the *proper application* of manures from organised substances, offers an illustration of an important part of the economy of nature, and of the happy order in which it is arranged. The death and decay of animal substances tend to resolve organised forms into chemical constituents; and the pernicious effluvia disengaged in the process seem to point out the propriety of burying them in the soil, where they are fitted to become the food of vegetables. The fermentation and putrefaction of organised substances in the free atmosphere are noxious processes; beneath the surface of the ground, they are salutary operations. In this case the food of plants is prepared where it can be used; and that which would offend the senses and injure the health, if exposed, is converted by gradual processes into forms of beauty and of usefulness; the fœtid gas is rendered a constituent of the aroma of the flower, and what might be poison becomes nourishment to animals and to man.

2212. *To preserve dung for any time*, the situation in which it is kept is of importance. It should, if possible, be defended from the sun. To preserve it under sheds would be of great use; or to make the site of a dunghill on the north side of a wall. The floor on which the dung is heaped, should, if possible, be paved with flat stones; and there should be a little inclination from each side towards the centre, in which there should be drains connected with a small well, furnished with a pump, by which any fluid matter may be collected for the use of the land. It too often happens that a dense mucilaginous and extractive fluid is suffered to drain away from the dunghill, so as to be entirely lost to the farm.

## SECT. II. *Of Manures of Mineral Origin.*

2213. *Earthy and saline manures* are probably of more recent invention, and doubtless of more uncertain use than those of animal and vegetable origin. The conversion of matter that has belonged to living structures into original forms, is a process that can be easily understood; but it is more difficult to follow those operations by which earthy and saline matters are consolidated in the fibre of plants, and by which they are made subservient to their functions. These are capable of being materially elucidated by modern chemistry, and shall here be considered as to the theory of their operation, and specific kinds.

### SUBJECT. 1. *Theory of the Operation of Mineral Manures.*

2214. *Saline and calcareous substances* form the principal fossil manures. Much has been written on lime and common salt, both in the way of speculation and reasoning from facts, which, from want of chemical knowledge, has turned to no useful account, and cultivators till very lately contented themselves with stating that these substances acted as stimuli to the soil, something like condiments to the digestive organs of animals. Even chemists themselves are not yet unanimous in all their opinions; but still the result of their enquiries will be found of great benefit to the scientific cultivator.

2215. *Various opinions* exist as to the rationale of the operation of mineral manures. "Some enquirers," Sir H. Davy observes, "adopting that sublime generalisation of the ancient philosophers, that matter is the same in essence, and that the different substances, considered as elements by chemists, are merely different arrangements of the same indestructible particles, have endeavored to prove, that all the varieties of the principles found in plants, may be formed from the substances in the atmosphere; and that vegetable life is a process in which bodies that the analytical philosopher is unable to change or to form, are constantly composed and decomposed. But the general results of experiments are very much opposed to the idea of the composition of the earths, by plants, from any of the elements found in the atmosphere, or in water, and there are various facts contradictory to the idea." Jacquin states, that the ashes of glass-wort

(*Salsola soda*), when it grows in inland situations, afford the vegetable alkali; when it grows on the sea-shore, where compounds which afford the fossil or marine alkali are more abundant, it yields that substance. Du Hamel found that plants which usually grow on the sea-shore, made small progress when planted in soils containing little common salt. The sun-flower, when growing in lands containing no nitre, does not afford that substance; though when watered by a solution of nitre, it yields nitre abundantly. The tables of De Saussure show that the ashes of plants are similar in constitution to the soils in which they have vegetated. De Saussure made plants grow in solutions of different salts; and he ascertained that, in all cases, certain portions of the salts were absorbed by the plants, and found unaltered in their organs. Even animals do not appear to possess the power of forming the alkaline and earthy substances. Dr. Fordyce found, that when canary-birds, at the time they were laying eggs, were deprived of access to carbonate of lime, their eggs had soft shells; and if there is any process for which nature may be conceived most likely to supply resources of this kind, it is that connected with the reproduction of the species.

2216. *It seems a fair conclusion*, as the evidence on the subject now stands, that the different earths and saline substances found in the organs of plants, are supplied by the soils in which they grow; and in no cases composed by new arrangements of the elements in air or water. What may be our ultimate view of the laws of chemistry, or how far our ideas of elementary principles may be simplified, it is impossible to say. We can only reason from facts. We cannot imitate the powers of composition belonging to vegetable structures; but at least we can understand them: and as far as our researches have gone, it appears that in vegetation compound forms are uniformly produced from simple ones: and the elements in the soil, the atmosphere and the earth absorbed and made parts of beautiful and diversified structures. The views which have been just developed lead to correct ideas of the operation of those manures which are not necessarily the result of decayed organised bodies, and which are not composed of different proportions of carbon, hydrogen, oxygen, and azote.—They must produce their effect, either by becoming a constituent part of the plant, or by acting upon its more essential food, so as to render it more fitted for the purposes of vegetable life.

#### SUBSECT. 2. *Of the different Species of Mineral Manures.*

2217. *Alkaline earths, or alkalis and their combinations*, which are found unmixed with the remains of any organised beings, are the only substances which can with propriety be called fossile manures. The only alkaline earths which have been hitherto applied in this way are lime and magnesia; though potassa and soda, the two fixed alkalis, are both used to a limited extent in certain of their chemical compounds.

2218. *The most common form in which lime is found on the surface of the earth*, is in a state of combination with carbonic acid or fixed air. If a piece of limestone or chalk be thrown into a fluid acid, there will be an effervescence. This is owing to the escape of the carbonic acid gas. The lime becomes dissolved in the liquor. When limestone is strongly heated, the carbonic acid gas is expelled, and then nothing remains but the pure alkaline earth; in this case there is a loss of weight; and if the fire has been very high, it approaches to one half the weight of the stone; but in common cases, limestones, if well dried before burning, do not lose much more than 35 to 40 per cent., or from seven to eight parts out of twenty.

2219. *When burnt lime is exposed to the atmosphere*, in a certain time it becomes mild, and is the same substance as that precipitated from lime-water; it is combined with carbonic acid gas. Quick-lime, when first made, is caustic and burning to the tongue, renders vegetable blues green, and is soluble in water; but when combined with carbonic acid, it loses all these properties, its solubility, and its taste: it regains its power of effervescing, and becomes the same chemical substance as chalk or limestone. Very few limestones or chalks consist entirely of lime and carbonic acid. The statuary marbles, or certain of the rhomboidal spars, are almost the only pure species; and the different properties of limestones, both as manures and cements, depend upon the nature of the ingredient mixed in the limestone; for the true calcareous element, the carbonate of lime, is uniformly the same in nature, properties, and effects, and consists of one proportion of carbonic acid 41.4, and one of lime 55. When a limestone does not copiously effervesce in acids, and is sufficiently hard to scratch glass, it contains siliceous, and probably aluminous earth. When it is deep brown or red, or strongly colored of any of the shades of brown or yellow, it contains oxide of iron. When it is not sufficiently hard to scratch glass, but effervesces slowly, and makes the acid in which it effervesces milky, it contains magnesia. And when it is black, and emits a fetid smell if rubbed, it contains coaly or bituminous matter. Before any opinion can be formed of the manner in which the different ingredients in limestones modify their properties, it will be necessary to consider the operation of pure lime as a manure.

2220. *Quick-lime, in its pure state, whether in powder, or dissolved in water, is injurious to plants.* In several instances grass has been killed by watering it with lime-water. But lime, in its state of combination with carbonic acid, is a useful ingredient in soils. Calcareous earth is found in the ashes of the greater number of plants; and exposed to the air, lime cannot long continue caustic, for the reasons that were just now assigned, but soon becomes united to carbonic acid. When newly-burnt lime is exposed to air, it soon falls into powder; in this case it is called slacked lime; and the same effect is immediately produced by throwing water upon it, when it heats violently, and the water disappears. Slacked lime is merely a combination of lime, with about one third of its weight of water; *i. e.* fifty-five parts of lime absorb seventeen parts of water; and in this case it is composed of a definite proportion of water, and is called by chemists *hydrate of lime*; and when hydrate of lime becomes carbonate of lime by long exposure to air, the water is expelled, and the carbonic acid gas takes its place. When lime, whether freshly burnt or slacked, is mixed with any moist fibrous vegetable matter, there is a strong action between the lime and the vegetable matter, and they form a kind of compost together, of which a part is usually soluble in water. By this kind of operation, lime renders matter which was before comparatively inert, nutritive; and as charcoal and oxygen abound in all vegetable matters, it becomes at the same time converted into carbonate of lime.

2221. *Mild lime, powdered limestone, marls, or chalks, have no action of this kind upon vegetable matter; they prevent the too rapid decomposition of substances already dissolved; but they have no tendency to form soluble matters.* It is obvious from these circumstances, that the operation of quick-lime, and marl, or chalk, depends upon principles altogether different. Quick-lime, in being applied to land, tends to bring any hard vegetable matter that it contains into a state of more rapid decomposition and solution, so as to render it a proper food for plants. Chalk and marl, or carbonate of lime, will only improve the texture of the soil, or its relation to absorption; it acts merely as one of its earthy ingredients. Chalk has been recommended as a substance calculated to correct the sourness of land. It would surely have been a wise practice to have previously ascertained the certainty of this existence of acid, and to have determined its nature, in order that it might be effectually removed. The fact really is, that no soil was ever yet found to contain any notable quantity of uncombined acid. The acetic and carbonic acids are the only two that are likely to be generated by any spontaneous decomposition of animal or vegetable bodies, and neither of these have any fixity when exposed to the air. Chalk having no power of acting on animal and vegetable substances, can be no otherwise serviceable to land than as it alters its texture. Quick-lime, when it becomes mild, operates in the same manner as chalk; but in the act of becoming mild, it prepares soluble out of insoluble matter. Boullion la Grange says, that gelatine oxygenised becomes insoluble, and vegetable extract we know becomes so from the same cause; now lime has the property of attracting oxygen, and, consequently, of restoring the property of solubility to those substances which have been deprived of it, from a combination with oxygen. Hence the uses of lime on peat lands, and on all soils containing an excess of vegetable insoluble matter. (*Crisenthuwaite.*)

2222. *Effect of lime on wheat crops.* When lime is employed upon land where there is present any quantity of animal matter, it occasions the evolution of a quantity of ammonia, which may, perhaps, be imbibed by the leaves of plants, and afterwards undergo some change so as to form gluten. It is upon this circumstance that the operation of lime in the preparation for wheat crops depends; and its efficacy in fertilising peat, and in bringing into a state of cultivation all soils abounding in hard roots, or dry fibres, or inert vegetable matter.

2223. *General principles for applying lime.* The solution of the question whether quick-lime ought to be applied to a soil, depends upon the quantity of inert vegetable matter that it contains. The solution of the question, whether marl, mild lime, or powdered limestone ought to be applied, depends upon the quantity of calcareous matter already in the soil. All soils are improved by mild lime, and ultimately by quick-lime, which do not effervesce with acids; and sands more than clays. When a soil, deficient in calcareous matter, contains much soluble vegetable manure, the application of quick-lime should always be avoided, as it either tends to decompose the soluble matters by uniting to their carbon and oxygen so as to become mild lime, or it combines with the soluble matters, and forms compounds having less attraction for water than the pure vegetable substance. The case is the same with respect to most animal manures; but the operation of the lime is different in different cases; and depends upon the nature of the animal matter. Lime forms a kind of insoluble soap with oily matters, and then gradually decomposes them by separating from them oxygen and carbon. It combines likewise with the animal acids, and probably assists their decomposition by abstracting carbonaceous matter from them combined with oxygen; and consequently it must render them less nutritive. It tends to diminish, likewise, the nutritive powers of albumen from

the same causes; and always destroys, to a certain extent, the efficacy of animal manures; either by combining with certain of their elements, or by giving to them new arrangements. Lime should never be applied with animal manures, unless they are too rich, or for the purpose of preventing noxious effluvia. It is injurious when mixed with any common dung, and tends to render the extractive matter insoluble. According to Chaptal (*Chimie appliquée*, &c. i. 153.) lime forms insoluble composts with almost all animal and vegetable substances that are soft, and thus destroys their fermentative properties. Such compounds, however, exposed to the continued action of the air, alter in course of time; the lime becomes carbonate; the animal or vegetable matters decompose by degrees, and furnish new products as vegetable nourishment. In this view, lime presents two great advantages for the nutrition of plants; the first, that of disposing certain insoluble bodies to form soluble compounds; the second, that of prolonging the action and nutritive qualities of substances, beyond the term which they would retain them if they were not made to enter into combination with lime. Thus the nutritive qualities of blood, as it exists in the compound of lime and blood known as sugar baker's scum, is moderated, prolonged, and given out by degrees: — blood alone applied directly to the roots of plants will destroy them with few or no exceptions.

2224. *Lime promotes fermentation.* In those cases in which fermentation is useful to produce nutriment from vegetable substances, lime is always efficacious. Some moist tanners' spent bark was mixed with one fifth of its weight of quick-lime, and suffered to remain together in a close vessel for three months; the lime had become colored, and was effervescent: when water was boiled upon the mixture, it gained a tint of fawn-color, and by evaporation furnished a fawn-colored powder, which must have consisted of lime united to vegetable matter, for it burnt when strongly heated, and left a residuum of mild lime.

2225. *Different kinds of limestones have different effects.* The limestones containing alumina and silica are less fitted for the purposes of manure than pure limestones; but the lime formed from them has no noxious quality. Such stones are less efficacious, merely because they furnish a smaller quantity of quick-lime. There is very seldom any considerable portion of coaly matter in bituminous limestones; never as much as five parts in 100; but such limestones make very good lime. The carbonaceous matter can do no injury to the land, and may, under certain circumstances, become a food of the plant.

2226. *The subject of the application of the magnesian limestone is one of great interest.* It had been long known to farmers in the neighborhood of Doncaster, that lime made from a certain limestone applied to the land, often injured the crops considerably. Tennant, in making a series of experiments upon this peculiar calcareous substance, found that it contained magnesia; and on mixing some calcined magnesia with soil, in which he sowed different seeds, he found that they either died or vegetated in a very imperfect manner, and the plants were never healthy. And with great justice and ingenuity he referred the bad effects of the peculiar limestone to the magnesian earth it contains.

2227. *Magnesian limestone is used with good effect in some cases.* Magnesia has a much weaker attraction for carbonic acid than lime, and will remain in the state of caustic or calcined magnesia for many months, though exposed to the air. And as long as any caustic lime remains, the magnesia cannot be combined with carbonic acid, for lime instantly attracts carbonic acid from magnesia. When a magnesian limestone is burnt, the magnesia is deprived of carbonic acid much sooner than the lime; and if there is not much vegetable or animal matter in the soil to supply by its decomposition carbonic acid, the magnesia will remain for a long while in the caustic state; and in this state acts as a poison to certain vegetables. And that more magnesian lime may be used upon rich soils, seems to be owing to the circumstance that the decomposition of the manure in them supplies carbonic acid. And magnesia, in its mild state, *i. e.* fully combined with carbonic acid, seems to be always a useful constituent of soils. Carbonate of magnesia (procured by boiling the solution of magnesia in supercarbonate of potassa,) was thrown upon grass, and upon growing wheat and barley, so as to render the surface white; but the vegetation was not injured in the slightest degree. And one of the most fertile parts of Cornwall, the Lizard, is a district in which the soil contains mild magnesian earth. It is obvious, from what has been said, that lime from the magnesian limestone may be applied in large quantities to peats; and that where lands have been injured by the application of too large a quantity of magnesian lime, peat will be a proper and efficient remedy.

2228. A simple *test of magnesia in a limestone* is its slight effervescence with acids, and its rendering diluted nitric acid, or aqua fortis, milky. From the analysis of Tennant, it appears to contain from 20·3 to 22·5 magnesia; 29·5 to 31·7 lime; 47·2 carbonic acid; 0·8 clay and oxide of iron. Magnesia limestones are usually colored brown or pale yellow. They are found in Somersetshire, Leicestershire, Derbyshire, Shropshire,

Durham, and Yorkshire; and in many parts of Ireland, particularly near Belfast. In general, when limestones are not magnesian, their purity will be indicated by their loss of weight in burning; the more they lose, the larger is the quantity of calcareous matter they contain. The magnesian limestones contain more carbonic acid than the common limestones; and I have found all of them lose more than half their weight by calcination.

2229. *Gypsum.* Besides being used in the forms of lime and carbonate of lime, calcareous matter is applied for the purposes of agriculture in other combinations. One of these bodies is gypsum or sulphate of lime. This substance consists of sulphuric acid (the same body that exists combined with water in oil of vitriol, and lime; and when dry it is composed of 55 parts of lime and 75 parts of sulphuric acid. Common gypsum or selenite, such as that found at Shotover Hill, near Oxford, contains, besides sulphuric acid and lime, a considerable quantity of water; and its composition may be thus expressed: sulphuric acid one proportion 75; lime one proportion 55; water two proportions 34.

2230. *The nature of gypsum* is easily demonstrated; if oil of vitriol be added to quick-lime, there is a violent heat produced; when the mixture is ignited, water is given off, and gypsum alone is the result, if the acid has been used in sufficient quantity; and gypsum mixed with quick-lime, if the quantity has been deficient. Gypsum, free from water, is sometimes found in nature, when it is called anhydrous selenite. It is distinguished from common gypsum by giving off no water when heated. When gypsum, free from water, or deprived of water by heat, is made into a paste with water, it rapidly sets by combining with that fluid. Plaster of Paris is powdered dry gypsum, and its property as a cement, and its use in making casts, depends upon its solidifying a certain quantity of water, and making with it a coherent mass. Gypsum is soluble in about 500 times its weight of cold water, and is more soluble in hot water; so that when water has been boiled in contact with gypsum, crystals of this substance are deposited as the water cools. Gypsum is easily distinguished by its properties of affording precipitates to solutions of oxalates and of barytic salts. It has been much used in America, where it was first introduced by Franklin on his return from Paris, who had been much struck with its effects there. He sowed the words, *This has been sown with gypsum*, on a field of lucern, near Washington; the effects astonished every passenger, and the use of the manure quickly became general, and signally efficacious. It has been advantageously used in Kent, but in most counties of England it has failed, though tried in various ways, and upon different crops.

2231. *Very discordant notions have been formed as to the mode of operation of gypsum.* It has been supposed by some persons to act by its power of attracting moisture from the air; but this agency must be comparatively insignificant. When combined with water, it retains that fluid too powerfully to yield it to the roots of the plant, and its adhesive attraction for moisture is inconsiderable; the small quantity in which it is used likewise is a circumstance hostile to this idea. It has been erroneously said that gypsum assists the putrefaction of animal substances, and the decomposition of manure.

2232. *The ashes of saintfoin, clover, and rye-grass, afford considerable quantities of gypsum;* and the substance probably is intimately combined as a necessary part of their woody fibre. If this be allowed, it is easy to explain the reason why it operates in such small quantities; for the whole of a clover crop, or saintfoin crop, on an acre, according to estimation, would afford by incineration only three or four bushels of gypsum. The reason why gypsum is not generally efficacious, is probably because most cultivated soils contain it in sufficient quantities for the use of the grasses. In the common course of cultivation, gypsum is furnished in the manure; for it is contained in stable dung, and in the dung of all cattle fed on grass; and it is not taken up in corn crops, or crops of peas and beans, and in very small quantities in turnip crops; but where lands are exclusively devoted to pasturage and hay, it will be continually consumed. Should these statements be confirmed by future enquiries, a practical inference of some value may be derived from them. It is possible that lands which have ceased to bear good crops of clover, or artificial grasses, may be restored by being manured with gypsum. This substance is found in Oxfordshire, Gloucestershire, Somersetshire, Derbyshire, Yorkshire, &c. and requires only pulverisation for its preparation.

2233. *Upon the use of sulphate of iron, or green vitriol,* which is a salt produced from peat in Bedfordshire, some very interesting documents have been produced by Dr. Pearson; and there is little doubt that the peat salt and the vitriolic water acted chiefly by producing gypsum. The soils on which both are efficacious are calcareous; and sulphate of iron is decomposed by the carbonate of lime in such soils. The sulphate of iron consists of sulphuric acid and oxide of iron, and is an acid and a very soluble salt; when a solution of it is mixed with carbonate of lime, the sulphuric acid quits the oxide of iron to unite to the lime, and the compounds produced are insipid and comparatively insoluble.



2234. *Vitriolic impregnations* in soils where there is no calcareous matter are injurious ; but it is probably in consequence of their supplying an excess of ferruginous matter to the sap. Oxide of iron, in small quantities, forms a useful part of soils ; it is found in the ashes of plants, and probably is hurtful only in its acid combinations. The ashes of all peats do not afford gypsum. In general, when a recent peat-ash emits a strong smell, resembling that of rotten eggs when acted upon by vinegar, it will furnish gypsum.

2235. *Phosphate of lime* is a combination of phosphoric acid and lime, one proportion of each. It is a compound insoluble in pure water, but soluble in water containing any acid matter. It forms the greatest part of calcined bones. It exists in most excrementitious substances, and is found both in the straw and grain of wheat, barley, oats, and rye, and likewise in beans, peas, and tares. It exists in some places in these islands native, but only in very small quantities. Phosphate of lime is generally conveyed to the land in the composition of other manure, and it is probably necessary to corn crops and other white crops.

2236. *Bone-ashes* calcined and ground to powder will probably be found useful on arable lands containing much vegetable matter, and may perhaps enable soft peats to produce wheat ; but the powdered bone in an uncalcined state is much to be preferred in all cases when it can be procured.

2237. *The saline compounds of magnesia* will require very little discussion as to their uses as manures. In combination with sulphuric acid, magnesia forms a soluble salt. This substance, it is stated by some enquirers, has been found of use as a manure ; but it is not found in nature in sufficient abundance, nor is it capable of being made artificially sufficiently cheap to be of useful application in the common course of husbandry.

2238. *Wood-ashes* consist principally of the vegetable alkali united to carbonic acid ; and as this alkali is found in almost all plants, it is not difficult to conceive that it may form an essential part of their organs. The general tendency of the alkalines is to give solubility to vegetable matters ; and in this way they may render carbonaceous and other substances capable of being taken up by the tubes in the radical fibres of plants. The vegetable alkali likewise has a strong attraction for water, and even in small quantities may tend to give a due degree of moisture to the soil, or to other manures ; though this operation, from the small quantities used or existing in the soil, can be only of a secondary kind.

2239. *The mineral alkali or soda* is found in the ashes of sea-weed, and may be procured by certain chemical agencies from common salt. Common salt consists of the metal named sodium, combined with chlorine ; and pure soda consists of the same metal united to oxygen. When water is present, which can afford oxygen to the sodium, soda may be obtained in several modes from salt. The same reasoning will apply to the operation of the pure mineral alkali, or the carbonated alkali, as to that of the vegetable alkali ; and when common salt acts as a manure, it is probably by entering into the composition of the plant in the same manner as gypsum, phosphate of lime, and the alkalies. Sir John Pringle has stated, that salt in small quantities assists the decomposition of animal and vegetable matter. This circumstance may render it useful in certain soils. Common salt, likewise, is offensive to insects. In small quantities it is sometimes a useful manure, and it is probable that its efficacy depends upon many combined causes. Some persons have argued against the employment of salt ; because when used in large quantities, it either does no good, or renders the ground sterile ; but this is a very unfair mode of reasoning. That salt in large quantities rendered land barren, was known long before any records of agricultural science existed. We read in the Scriptures, that Abimelech took the city of Shechem, "and beat down the city, and sowed it with salt ;" that the soil might be for ever unfruitful. Virgil reprobates a salt soil ; and Pliny, though he recommends giving salt to cattle, yet affirms, that when strewed over land it renders it barren. But these are not arguments against a proper application of it. Refuse salt in Cornwall, which, however, likewise contains some of the oil and exuviae of fish, has long been known as an admirable manure. And the Cheshire farmers contend for the benefit of the peculiar produce of their county. It is not unlikely, that the same causes influence the effects of salt, as those which act in modifying the operation of gypsum. Most lands in this island, particularly those near the sea, probably contain a sufficient quantity of salt for all the purposes of vegetation ; and in such cases the supply of it to the soil will not only be useless, but may be injurious. In great storms the spray of the sea has been carried more than fifty miles from the shore ; so that from this source salt must be often supplied to the soil. Salt is found in almost all sandstone rocks, and it must exist in the soil derived from these rocks. It is a constituent likewise of almost every kind of animal and vegetable manure.

2240. *Other compounds.* Besides these compounds of the alkaline earths and alkalies, many others have been recommended for the purposes of increasing vegetation ; such

are nitre, or the nitrous acid combined with potassa. Sir Kenelm Digby states, that he made barley grow very luxuriantly by watering it with a very weak solution of nitre; but he is too speculative a writer to awaken confidence in his results. This substance consists of one proportion of azote, six of oxygen, and one of potassium; and it is not unlikely that it may furnish azote to form albumen or gluten in those plants that contain them; but the nitrous salts are too valuable for other purposes to be used as manures. Dr. Home states, that sulphate of potassa, which was just now mentioned as found in the ashes of some peats, is a useful manure. But Naismith (*Elements of Agriculture*, p. 78.) questions his results; and quotes experiments hostile to his opinions, and, as he conceives, unfavorable to the efficacy of any species of saline manure. Much of the discordance of the evidence relating to the efficacy of saline substances depends upon the circumstance of their having been used in different proportions, and, in general, in quantities much too large.

2241. *Solutions of saline substances* were used twice a week, in the quantity of two ounces, on spots of grass and corn, sufficiently remote from each other to prevent any interference of results. The substances tried were super-carbonate, sulphate, acetate, nitrate, and muriate of potassa; sulphate of soda; sulphate, nitrate, muriate, and carbonate of ammonia. It was found, that in all cases when the quantity of the salt equalled one thirtieth part of the weight of the water, the effects were injurious; but least so in the instance of the carbonate, sulphate, and muriate of ammonia. When the quantities of the salts were one three-hundredth part of the solution, the effects were different. The plants watered with the solutions of the sulphates grew just in the same manner as similar plants watered with rain-water. Those acted on by the solution of nitre, acetate, and super-carbonate of potassa, and muriate of ammonia, grew rather better. Those treated with the solution of carbonate of ammonia grew most luxuriantly of all. This last result is what might be expected, for carbonate of ammonia consists of carbon, hydrogen, azote, and oxygen. There was, however, another result which was not anticipated; the plants watered with solution of nitrate of ammonia did not grow better than those watered with rain-water. The solution reddened litmus paper; and probably the free acid exerted a prejudicial effect, and interfered with the result.

2242. *Soot* doubtless owes part of its efficacy to the ammoniacal salts it contains. The liquor produced by the distillation of coal contains carbonate and acetate of ammonia, and is said to be a very good manure.

2243. *Soapers' waste* has been recommended as a manure, and it has been supposed that its efficacy depended upon the different saline matters it contains; but their quantity is very minute indeed, and its principal ingredients are mild lime and quick-lime. In the soapers' waste, from the best manufactories, there is scarcely a trace of alkali. Lime, moistened with sea-water, affords more of this substance, and is said to have been used in some cases with more benefit than common lime.

2244. *The result of Sir H. Davy's discussion as to the extent of the effects of saline substances on vegetation*, is, that except the ammoniacal compounds, or the compounds containing nitric, acetic, and carbonic acid, none of them can afford by their decomposition any of the common principles of vegetation — carbon, hydrogen, and oxygen. The alkaline sulphates and the earthy muriates are so seldom found in plants, or are found in such minute quantities, that it can never be an object to apply them to the soil. The earthy and alkaline substances seem never to be formed in vegetation; and there is every reason to believe, that they are never decomposed; for, after being absorbed, they are found in their ashes. The metallic bases of them cannot exist in contact with aqueous fluids; and these metallic bases, like other metals, have not as yet been resolved into any other forms of matter by artificial processes; they combined readily with other elements; but they remain indestructible, and can be traced undiminished in quantity, through their diversified combinations.

---

### CHAP. III.

#### *Of the Agency of Heat, Light, Electricity, and Water, in Vegetable Culture.*

2245. The particular agency of heat, light, and water in vegetation and culture has been so frequently illustrated, that it only remains to give a general idea of their natures, and to offer some remarks on electricity.

#### SECT. I. *Of Heat and Light.*

2246. *The heat of the sun is the cause of growth, and its light the cause of maturity*, in the vegetable kingdom. This is universally acknowledged: animals will live without or with very little light; but no plants whatever can exist for any time without the presence of this element. The agency of electricity in vegetation is less known.

2247. *Two opinions are current respecting the nature of heat.* By some philosophers it is conceived to be a peculiar subtile fluid, of which the particles repel each other, but have a strong attraction for the particles of other matter. By others it is considered as a motion or vibration of the particles of matter, which is supposed to differ in velocity in different cases, and thus to produce the different degrees of temperature. Whatever decision be ultimately made respecting these opinions, it is certain that there is matter moving in the space between us and the heavenly bodies capable of communicating heat; the motions of which are rectilinear: thus the solar rays produce heat in acting on the surface of the earth. The beautiful experiments of Dr. Herschel have shown that there are rays transmitted from the sun which do not illuminate, and which yet produce more heat than the visible rays; and Ritter and Dr. Willaston have shown that there are other invisible rays distinguished by their chemical effects.

2248. *Heat is radiated by the sun to the earth,* and if suffered to accumulate, Dr. Wells observes, would quickly destroy the present constitution of our globe. This evil is prevented by the radiation of heat from the earth to the heavens, during the night, when it receives from them little or no heat in return. But through the wise economy of means, which is witnessed in all the operations of nature, the prevention of this evil is made the source of great positive good. For the surface of the earth, having thus become colder than the neighboring air, condenses a part of the watery vapor of the atmosphere into dew, the utility of which is too manifest to require elucidation. This fluid appears chiefly where it is most wanted, on herbage and low plants, avoiding, in great measure, rocks, bare earth, and considerable masses of water. Its production, too, tends to prevent the injury that might arise from its own cause; since the precipitation of water, upon the tender parts of plants, must lessen the cold in them, which occasions it. The prevention, either wholly or in part, of cold, from radiation, in substances on the ground, by the interposition of any solid body between them and the sky, arises in the following manner: the lower body radiates its heat upwards, as if no other intervened between it and the sky; but the loss, which it hence suffers, is more or less compensated by what is radiated to it, from the body above, the under surface of which possesses always the same, or very nearly the same temperature as the air. The manner in which clouds prevent, or occasion to be small, the appearance of a cold at night, upon the surface of the earth, is by radiating heat to the earth, in return for that which they intercept in its progress from the earth towards the heavens. For although, upon the sky becoming suddenly cloudy during a calm night, a naked thermometer, suspended in the air, commonly rises 2 or 3 degrees: little of this rise is to be attributed to the heat evolved by the condensation of watery vapor in the atmosphere, for the heat so extricated must soon be dissipated; whereas the effect of greatly lessening, or preventing altogether, the appearance of a superior cold on the earth to that of the air, will be produced by a cloudy sky, during the whole of a long night.

2249. *Dense clouds, near the earth, reflect back the heat they receive from it by radiation.* But similar dense clouds, if very high, though they equally intercept the communication of the earth with the sky, yet being, from their elevated situation, colder than the earth, will radiate to it less heat than they receive from it, and may, consequently, admit of bodies on its surface becoming several degrees colder than the air. Islands, and parts of continents close to the sea, being, by their situations, subject to a cloudy sky, will, from the smaller quantity of heat lost by them through radiation to the heavens, at night, in addition to the reasons commonly assigned, be less cold in winter, than countries considerably distant from any ocean.

2250. *Fogs, like clouds, will arrest heat,* which is radiated upwards by the earth, and if they be very dense, and of considerable perpendicular extent, may remit to it as much as they receive. Fogs do not, in any instance, furnish a real exception to the general rule, that whatever exists in the atmosphere, capable of stopping or impeding the passage of radiant heat, will prevent or lessen the appearance at night of a cold on the surface of the earth, greater than that of the neighboring air. The water deposited upon the earth, during a fog at night, may sometimes be derived from two different sources, one of which is a precipitation of moisture from a considerable part of the atmosphere, in consequence of its general cold; the other, a real formation of dew, from the condensation, by means of the superficial cold of the ground, of the moisture of that portion of the air, which comes in contact with it. In such a state of things, all bodies will become moist, but those especially which most readily attract dew in clear weather.

2251. *When bodies become cold by radiation,* the degree of effect observed must depend, not only on their radiating power, but in part also on the greater or less ease with which they can derive heat, by conduction, from warmer substances in contact with them. Bodies, exposed in a clear night to the sky, must radiate as much heat to it during the prevalence of wind, as they would do if the air were altogether still. But in the former case, little or no cold will be observed upon them above that of the atmosphere, as the frequent application of warm air must quickly return a heat equal, or nearly so, to that

which they had lost by radiation. A slight agitation of the air is sufficient to produce some effect of this kind; though, as has already been said, such an agitation, when the air is very pregnant with moisture, will render greater the quantity of dew, one requisite for a considerable production of this fluid being more increased by it, than another is diminished.

2252. It has been remarked, that *the hurtful effects of cold occur chiefly in hollow places*. If this be restricted to what happens on the serene and calm nights, two reasons from different sources are to be assigned for it. The first is, that the air being still in such a situation, than in any other, the cold, from radiation, in the bodies which it contains, will be less diminished by renewed applications of warmer air; the second, that from the longer continuance of the same air in contact with the ground, in depressed places than in others, less dew will be deposited, and therefore less heat extricated during its formation.

2253. An observation closely connected with the preceding, namely, that *in clear and still nights, frosts are less severe upon the hills, than in neighboring plains*, has excited more attention, chiefly from its contradicting what is commonly regarded an established fact, that the cold of the atmosphere always increases with the distance from the earth. But on the contrary the fact is certain, that in very clear and still nights, the air near to the earth is colder than that which is more distant from it, to the height at least of 220 feet, this being the greatest to which experiments relate. If then a hill be supposed to rise from a plain to the height of 220 feet, having upon its summit a small flat surface covered with grass; and if the atmosphere, during a calm and serene night, be admitted to be  $10^{\circ}$  warmer there than it is near the surface of the low grounds, which is a less difference than what sometimes occurs in such circumstances, it is manifest that, should both the grass upon the hill, and that upon the plain, acquire a cold of  $10^{\circ}$  by radiation, the former will, notwithstanding, be  $10^{\circ}$  warmer than the latter. Hence also the tops of trees are sometimes found dry when the grass on the ground's surface has been found covered with dew.

2254. *A very slight covering will exclude much cold*. I had often, observes Dr. Wells, in the pride of half knowledge, smiled at the means frequently employed by gardeners, to protect tender plants from cold, as it appeared to me impossible, that a thin mat, or any such flimsy substance, could prevent them from attaining the temperature of the atmosphere, by which alone I thought them liable to be injured. But, when I had learned, that bodies on the surface of the earth become, during a still and serene night, colder than the atmosphere, by radiating their heat to the heavens, I perceived immediately a just reason for the practice, which I had before deemed useless. Being desirous, however, of acquiring some precise information on this subject, I fixed, perpendicularly, in the earth of a grass plot, four small sticks, and over their upper extremities, which were six inches above the grass, and formed the corners of a square, the sides of which were two feet long, drew tightly a very thin cambric handkerchief. In this disposition of things, therefore, nothing existing to prevent the free passage of air from the exposed grass, to that which was sheltered, except the four small sticks, and there was no substance to radiate heat downwards to the latter grass, except the cambric handkerchief. The temperature of the grass, which was thus shielded from the sky, was, upon many nights afterwards examined by me, and was always found higher than that of neighboring grass which was uncovered, if this was colder than the air. When the difference in temperature, between the air several feet above the ground and the unsheltered grass, did not exceed  $5^{\circ}$ , the sheltered grass was about as warm as the air. If that difference, however, exceeded  $5^{\circ}$ , the air was found to be somewhat warmer than the sheltered grass. Thus, upon one night, when fully exposed grass was  $11^{\circ}$  colder than the air, the latter was  $5^{\circ}$  warmer than the sheltered grass; and the same difference existed on another night, when the air was  $14^{\circ}$  warmer than the exposed grass. One reason for this difference, no doubt, was that the air, which passed from the exposed grass, by which it had been very much cooled, to that under the handkerchief, had deprived the latter of part of its heat; another, that the handkerchief, from being made colder than the atmosphere by the radiation of its upper surface to the heavens, would remit somewhat less heat to the grass beneath, than what it received from that substance. But still, as the sheltered grass, notwithstanding these drawbacks, was upon one night, as may be collected from the preceding relation,  $8^{\circ}$ , and upon another  $11^{\circ}$ , warmer than grass fully exposed to the sky, a sufficient reason was now obtained for the utility of a very slight shelter to plants, in averting or lessening injury from cold, on a still and serene night.

2255. *The covering has most effect when placed at a little distance above the plants or objects to be sheltered*. A difference in temperature, of some magnitude, was always observed on still and serene nights, between bodies sheltered from the sky by substances touching them, and similar bodies, which were sheltered by a substance a little above them. I found, for example, upon one night, that the warmth of grass, sheltered by a

cambric handkerchief raised a few inches in the air, was  $3^{\circ}$  greater than that of a neighboring piece of grass which was sheltered by a similar handkerchief actually in contact with it. On another night, the difference between the temperatures of two portions of grass, shielded in the same manner, as the two above mentioned, from the influence of the sky, was  $4^{\circ}$ . Possibly, continues Dr. Wells, experience has long ago taught gardeners the superior advantage of defending tender vegetables, from the cold of clear and calm nights, by means of substances not directly touching them; though I do not recollect ever having seen any contrivance for keeping mats, or such like bodies, at a distance from the plants which they were meant to protect.

2256. *Heat produced by walls.* Walls, Dr. Wells observes, as far as warmth is concerned, are regarded as useful, during a cold night, to the plants which touch them, or are near to them, only in two ways; first, by the mechanical shelter which they afford against cold winds, and secondly, by giving out the heat which they had acquired during the day. It appearing to me, however, that, on clear and calm nights, those on which plants frequently receive much injury from cold, walls must be beneficial in a third way, namely, by preventing, in part, the loss of heat, which the plants would sustain from radiation, if they were fully exposed to the sky: the following experiment was made for the purpose of determining the justness of this opinion. A cambric handkerchief having been placed, by means of two upright sticks, perpendicularly to a grass-plot, and at right angles to the course of the air, a thermometer was laid upon the grass close to the lower edge of the handkerchief, on its windward side. The thermometer thus situated was several nights compared with another lying on the same grass-plot, but on a part of it fully exposed to the sky. On two of these nights, the air being clear and calm, the grass close to the handkerchief was found to be  $4^{\circ}$  warmer than the fully exposed grass. On a third, the difference was  $6^{\circ}$ . An analogous fact is mentioned by Gersten, who says, that a horizontal surface is more abundantly dewed, than one which is perpendicular to the ground.

2257. *Heat from a covering of snow.* The covering of snow, the same author observes, which countries in high latitudes enjoy during the winter, has been very commonly thought to be beneficial to vegetable substances on the surface of the earth, as far as their temperature is concerned, solely by protecting them from the cold of the atmosphere. But were this supposition just, the advantage of the covering would be greatly circumscribed; since the upper parts of trees and of tall shrubs are still exposed to the influence of the air. Another reason, however, is furnished for its usefulness, by what has been said in this essay; which is, that it prevents the occurrence of the cold, which bodies on the earth acquire, in addition to that of the atmosphere, by the radiation of their heat to the heavens during still and clear nights. The cause, indeed, of this additional cold, does not constantly operate; but its presence, during only a few hours, might effectually destroy plants, which now pass unhurt through the winter. Again, as things are, while low vegetable productions are prevented, by their covering of snow, from becoming colder than the atmosphere in consequence of their own radiation, the parts of trees and tall shrubs, which rise above the snow, are little affected by cold from this cause. For their uttermost twigs, now that they are destitute of leaves, are much smaller than the thermometers suspended by me in the air, which in this situation very seldom became more than  $2^{\circ}$  colder than the atmosphere. The larger branches, too, which, if fully exposed to the sky, would become colder than the extreme parts, are, in a great degree, sheltered by them; and, in the last place, the trunks are sheltered both by the smaller and larger parts, not to mention that the trunks must derive heat, by conduction through the roots, from the earth kept warm by the snow. In a similar way is partly to be explained the manner, in which a layer of earth or straw preserves vegetable matters in our own fields, from the injurious effects of cold in winter. (*Essay on Dew*, &c. 1819.)

2258. *The nature of light is totally unknown:* the light which proceeds from the sun seems to be composed of three distinct substances. Scheele discovered that a glass mirror held before the fire reflected the rays of light, but not the rays of caloric; but when a metallic mirror was placed in the same situation, both heat and light were reflected. The mirror of glass became hot in a short time, but no change of temperature took place on the metallic mirror. This experiment shows that the glass mirror absorbed the rays of caloric, and reflected those of light; while the metallic mirror, suffering no change of temperature, reflected both. And if a plate glass be held before a burning body, the rays of light are not sensibly interrupted, but the rays of caloric are intercepted; for no sensible heat is observed on the opposite side of the glass; but when the glass has reached a proper degree of temperature, the rays of caloric are transmitted with the same facility as those of light. And thus the rays of light and caloric may be separated. But the curious experiments of Dr. Herschel have clearly proved that the invisible rays which are emitted by the sun, have the greatest heating power. In those experiments, the different colored rays were thrown on the bulb of a very delicate thermometer, and their

heating power was observed. The heating power of the violet, green, and red rays were found to be to each other as the following numbers;— Violet, 16·0; Green 22·4; Red, 55·0. The heating power of the most refrangible rays was least, and this power increases as the refrangibility diminishes. The red ray, therefore, has the greatest heating power, and the violet, which is the most refrangible, the least. The illuminating power, it has been already observed, is greatest in the middle of the spectrum, and it diminishes towards both extremities; but the heating power, which is least at the violet end, increases from that to the red extremity; and when the thermometer was placed beyond the limit of the red ray, it rose still higher than in the red ray, which has the greatest heating power in the spectrum. The heating power of these invisible rays was greatest at the distance of half an inch beyond the red ray, but it was sensible at the distance of one inch and a half.

2259. *The influence of the different solar rays on vegetation* has not yet been studied; but it is certain that the rays exercise an influence independent of the heat they produce. Thus plants kept in darkness, but supplied with heat, air, and moisture, grow for a short time, but they never gain their natural colors; their leaves are white and pale, and their juices watery and peculiarly saccharine: according to Knight they merely expend the sap previously generated under the influence of light. (*Notes to Sir H. Davy's Agr. Chem.* p. 402.)

#### SECT. II. *Of Electricity.*

2260. *Electrical changes are constantly taking place* in nature, on the surface of the earth, and in the atmosphere; but as yet the effects of this power in vegetation have not been correctly estimated. It has been shown by experiments made by means of the voltaic battery, that compound bodies in general, are capable of being decomposed by electrical powers, and it is probable that the various electrical phenomena occurring in our system, must influence both the germination of seeds and the growth of plants. It has been found that corn sprouted much more rapidly in water positively electrified by the voltaic instrument, than in water negatively electrified; and experiments made upon the atmosphere show that clouds are usually negative; and, as when a cloud is in one state of electricity, the surface of the earth beneath is brought into the opposite state, it is probable that in common cases the surface of the earth is positive. A similar experiment is related by Dr. Darwin. (*Phytologia*, sect. xiii. 2, 3.)

2261. *Respecting the nature of electricity* different opinions are entertained amongst scientific men; by some, the phenomena are conceived to depend upon a single subtle fluid in excess in the bodies said to be positively electrified, and in deficiency in the bodies said to be negatively electrified. A second class suppose the effects to be produced by two different fluids, called by them the vitreous fluid and the resinous fluid; and others regard them as affections or motions of matter, or an exhibition of attractive powers, similar to those which produce chemical combination and decomposition; but usually exerting their action on masses.

2262. *A profitable application of electricity*, Dr. Darwin observes, to promote the growth of plants is not yet discovered; it is nevertheless probable, that in dry seasons, the erection of numerous metallic points on the surface of the ground, but a few feet high, might, in the night-time, contribute to precipitate the dew by facilitating the passage of electricity from the air into the earth; and that an erection of such points higher in the air by means of wires wrapped round tall rods, like angle rods, or elevated on buildings, might frequently precipitate showers from the higher parts of the atmosphere. Such points erected in gardens might promote a quicker vegetation of the plants in their vicinity, by supplying them more abundantly with the electric ether. (*Phytologia*, xiii. 4.) J. Williams (*Climate of Great Britain*, 348.), enlarging on this idea, proposes to erect large electrical machines, to be driven by wind, over the general face of the country, for the purpose of improving the climate, and especially for lessening that superabundant moisture which he contends is yearly increasing from the increased evaporating surface, produced by the vegetation of improved culture, and especially from the increase of pastures, hedges, and ornamental plantations.

#### SECT. III. *Of Water.*

2263. *Water is a compound of oxygene and hydrogen gas*, though primarily reckoned a simple or elementary substance. "If the metal called potassium be exposed in a glass tube to a small quantity of water, it will act upon it with great violence; elastic fluid will be disengaged, which will be found to be hydrogen; and the same effects will be produced upon the potassium, as if it had absorbed a small quantity of oxygen; and the hydrogen disengaged, and the oxygen added to the potassium, are in weight as 2 to 15; and if two in volume of hydrogen, and one in volume of oxygen, which have the weights of 2 and 15, be introduced into a close vessel, and an electrical spark passed through them, they will inflame and condense into 17 parts of pure water."

2264. *Water is absolutely necessary to the economy of vegetation* in its elastic and fluid state; and it is not devoid of use even in its solid form. Snow and ice are bad conductors of heat; and when the ground is covered with snow, or the surface of the soil or of water is frozen, the roots or bulbs of the plants beneath are protected by the congealed water from the influence of the atmosphere, the temperature of which, in northern winters, is usually very much below the freezing point; and this water becomes the first nourishment of the plant in early spring. The expansion of water during its congelation, at which time its volume increases one twelfth, and its contraction of bulk during a thaw, tend to pulverise the soil, to separate its parts from each other, and to make it more permeable to the influence of the air.

---

#### CHAP. IV.

##### *Of the Agency of the Atmosphere in Vegetation.*

2265. *The aerial medium which envelopes the earth* may be studied chemically and physically; the first study respects the elements of which the atmosphere is composed; and the second their action in a state of combination, and as influenced by various causes, or those phenomena which constitute the weather.

##### SECT. I. *Of the Elements of the Atmosphere.*

2266. *Water, carbonic acid gas, oxygen, and azote,* are the principal substances composing the atmosphere; but more minute enquiries respecting their nature and agencies are necessary to afford correct views of its uses in vegetation.

2267. *That water exists in the atmosphere* is easily proved. If some of the salt, called muriate of lime, that has been just heated red, be exposed to the air, even in the driest and coldest weather, it will increase in weight, and become moist; and in a certain time will be converted into a fluid. If put into a retort and heated, it will yield pure water; will gradually recover its pristine state; and, if heated red, its former weight: so that it is evident that the water united to it was derived from the air. And that it existed in the air in an invisible and elastic form, is proved by the circumstances, that if a given quantity of air be exposed to the salt, its volume and weight will diminish, provided the experiment be correctly made.

2268. *The quantity of water which exists in air,* as vapor, varies with the temperature. In proportion as the weather is hotter, the quantity is greater. At 50° of Fahrenheit, air contains about one 50th of its volume of vapor; and as the specific gravity of vapor is to that of air nearly as 10 to 15; this is about one 75th of its weight. At 100°, supposing that there is a free communication with water, it contains about one 14th part in volume, or one 21st in weight. It is the condensation of vapor by diminution of the temperature of the atmosphere, which is probably the principal cause of the formation of clouds, and of the deposition of dew, mist, snow, or hail.

2269. *The power of different substances to absorb aqueous vapor* from the atmosphere by cohesive attraction has been already referred to (2102.) The leaves of living plants appear to act upon this vapor in its elastic form, and to absorb it. Some vegetables increase in weight from this cause, when suspended in the atmosphere and unconnected with the soil; such are the house-leek, and different species of the aloe. In very intense heats, and when the soil is dry, the life of plants seems to be preserved by the absorbent power of their leaves; and it is a beautiful circumstance in the economy of nature, that aqueous vapor is most abundant in the atmosphere when it is most needed for the purposes of life; and that when other sources of its supply are cut off, this is most copious.

2270. *The existence of carbonic acid gas in the atmosphere* is proved by the following process: if a solution of lime and water be exposed to the air, a pellicle will speedily form upon it, and a solid matter will gradually fall to the bottom of the water, and in a certain time the water will become tasteless; this is owing to the combination of the lime which was dissolved in the water with carbonic acid gas, which existed in the atmosphere, as may be proved by collecting the film and the solid matter, and igniting them strongly in a little tube of platina or iron; they will give out carbonic acid gas, and will become quick-lime, which, added to the same water, will again bring it to the state of lime-water.

2271. *The quantity of carbonic acid gas in the atmosphere* is very small. It is not easy to determine it with precision, and it must differ in different situations; but where there is a free circulation of air, it is probably never more than one 500th, nor less than one 800th of the volume of air. Carbonic acid gas is nearly one third heavier than the other elastic parts of the atmosphere in their mixed state; hence at first view it might be supposed

that it would be most abundant in the lower regions of the atmosphere; but unless it has been immediately produced at the surface of the earth in some chemical process, this does not seem to be the case; elastic fluids of different specific gravities have a tendency to equable mixture by a species of attraction, and the different parts of the atmosphere are constantly agitated and blended together by winds or other causes. De Saussure found lime-water precipitated on Mount Blanc, the highest point of land in Europe; and carbonic acid gas has been always found, apparently in due proportion, in the air brought down from great heights in the atmosphere by aerostatic adventurers.

2272. *The principal consumption of the carbonic acid in the atmosphere seems to be in affording nourishment to plants; and some of them appear to be supplied with carbon chiefly from this source.*

2273. *The formation of carbonic acid gas takes place during fermentation, combustion, putrefaction, respiration, and a number of operations taking place upon the surface of the earth; and there is no other process known in nature, by which it can be destroyed but by vegetation.*

2274. *Oxygen and azote are the remaining constituents of the atmosphere. After a given portion of common air has been deprived of aqueous vapor and carbonic acid gas, it appears little altered in its properties; it remains a compound of oxygen and azote, which supports combustion and animal life. There are many modes of separating these two gases from each other. A simple one is by burning phosphorus in a confined volume of air; this absorbs the oxygen and leaves the azote; and 100 parts in volume of air, in which phosphorus has been burnt, yield 79 parts of azote; and by mixing this azote with 21 parts of fresh oxygen gas artificially procured, a substance having the original characters of air is produced. To procure pure oxygen from air, quicksilver may be kept heated in it, at about 600°, till it becomes a red powder; this powder, when ignited, will be restored to the state of quicksilver by giving off oxygen.*

2275. *Oxygen is necessary to some functions of vegetables; but its great importance in nature is its relation to the economy of animals. It is absolutely necessary to their life. Atmospheric air taken into the lungs of animals, or passed in solution in water through the gills of fishes, loses oxygen; and for the oxygen lost, about an equal volume of carbonic acid appears.*

2276. *The effects of azote in vegetation are not distinctly known. As it is found in some of the products of vegetation, it may be absorbed by certain plants from the atmosphere. It prevents the action of oxygen from being too energetic, and serves as a medium in which the more essential parts of the air act; nor is this circumstance un-conformable to the analogy of nature; for the elements most abundant on the solid surface of the globe, are not those which are the most essential to the existence of the living beings belonging to it.*

2277. *The action of the atmosphere on plants differs at different periods of their growth, and varies with the various stages of the developement and decay of their organs. If a healthy seed be moistened and exposed to air at a temperature not below 45°, it soon germinates, and shoots forth a plume, which rises upwards, and a radicle which descends. If the air be confined, it is found that in the process of germination the oxygen, or a part of it, is absorbed. The azote remains unaltered; no carbonic acid is taken away from the air; on the contrary, some is added. Seeds are incapable of germinating, except when oxygen is present. In the exhausted receiver of the air-pump, in pure azote, or in pure carbonic acid, when moistened they swell, but do not vegetate; and if kept in these gases, lose their living powers, and undergo putrefaction. If a seed be examined before germination, it will be found more or less insipid, at least not sweet; but after germination it is always sweet. Its coagulated mucilage, or starch, is converted into sugar in the process; a substance difficult of solution is changed into one easily soluble; and the sugar carried through the cells or vessels of the cotyledons, is the nourishment of the infant plant. The absorption of oxygen by the seed in germination has been compared to its absorption in producing the evolution of fetal life in the egg; but this analogy is only remote. All animals, from the most to the least perfect classes, require a supply of oxygen. From the moment the heart begins to pulsate till it ceases to beat, the aeration of the blood is constant, and the function of respiration invariable; carbonic acid is given off in the process, but the chemical change produced in the blood is unknown; nor is there any reason to suppose the formation of any substance similar to sugar. It is evident, that in all cases of semination, the seeds should be sown so as to be fully exposed to the influence of the air. And one cause of the unproductiveness of cold clayey adhesive soils is, that the seed is coated with matter impermeable to air. In sandy soils the earth is always sufficiently penetrable by the atmosphere; but in clayey soils there can scarcely be too great a mechanical division of parts. Any seed not fully supplied with air, always produces a weak and diseased plant. We have already seen (1530.) that carbon is added to plants from the air by the process of vegetation in sunshine; and oxygen is added to the atmosphere at the same time.*



2278. *Those changes in the atmosphere which constitute the most important meteorological phenomena, may be classed under five distinct heads; the alterations that occur in the weight of the atmosphere; those that take place in its temperature; the changes produced in its quantity by evaporation and rain; the excessive agitation to which it is frequently subject; and the phenomena arising from electric and other causes, that at particular times occasion or attend the precipitations and agitations alluded to. All the above phenomena prove to demonstration that constant changes take place, the consequences of new combinations and decompositions rapidly following each other.*

2279. *With respect to the changes in the weight of the atmosphere, it is generally known that the instrument called the barometer shows the weight of a body of air immediately above it, extending to the extreme boundary of the atmosphere, and the base of which is equal to that of the mercury contained within it. As the level of the sea is the lowest point of observation, the column of air over a barometer placed at that level is the longest to be obtained.*

2280. *The variations of the barometer between the tropics are very trifling, and it does not descend more than half as much in that part of the globe for every two hundred feet of elevation as it does beyond the tropics. The range of the barometer increases gradually as the latitude advances towards the poles, till in the end it amounts to two or three inches. The following Table will explain this gradual increase:—*

Latitude.	Places.	Range of the Barometer.	
		Greatest.	Annual.
0° 0°	Peru - - -	0 20	— —
22 23	Calcutta - -	0 77	— —
33 55	Cape Town -	— —	0 89
40 55	Naples - - -	1 00	— —
51 8	Dover - - -	2 47	1 80
53 13	Middlewich -	3 00	1 94
53 23	Liverpool - -	2 89	1 96
59 56	Petersburgh -	3 45	2 77

2281. *The range of the barometer is considerably less in North America than in the corresponding latitudes of Europe, particularly in Virginia, where it never exceeds 1·1. The range is more considerable at the level of the sea than on mountains; and in the same degree of latitude it is in the inverse ratio of the height of the place above the level of the sea. Cotte composed a table, which has been published in the *Journal de Physique*, from which it appears extremely probable, that the barometer has an invariable tendency to rise between the morning and the evening, and that this impulse is most considerable from two in the afternoon till nine at night, when the greatest elevation is accomplished; but the elevation at nine*

differs from that at two by four twelfths, while that of two varies from the elevation of the morning only by one twelfth, and that in particular climates the greatest elevation is at two o'clock. The observations of Cotte confirm those of Luke Howard; and from them it is concluded, that the barometer is influenced by some depressing cause at new and full moon, and that some other makes it rise at the quarters. This coincidence is most considerable in fair and calm weather; the depression in the interval between the quarters and conjunctions amounts to one tenth of an inch, and the rise from the conjunctions to the quarters is to the same amount. The range of this instrument is found to be greater in winter than in summer; for instance, the mean at York, during the months from October to March inclusive, in the year 1774, was 1·42, and in the six summer months 1·016.

2282. *The more serene and settled the weather, the higher the barometer ranges; calm weather, with a tendency to rain, depresses it; high winds have a similar effect on it; and the greatest elevation occurs with easterly and northerly winds; but the south produces a directly contrary effect.*

2283. *The variations in the temperature of the air in any particular place, exclusive of the differences of seasons and climates, are very considerable. These changes cannot be produced by heat derived from the sun, as its rays concentrated have no kind of effect on air; those, however, heat the surface of our globe, which is communicated to the immediate atmosphere; it is through this fact that the temperature is highest where the place is so situated as to receive with most effect the rays of the sun, and that it varies in each region with the season; it is also the cause why it decreases in proportion to the height of the air above the surface of the earth. The most perpendicular rays falling on the globe at the equator, there the heat of it is the greatest, and that heat decreases gradually to the poles, of course the temperature of the air is in exact unison; from this, it appears, that the air acquires the greatest degree of warmth over the equator, where it becomes insensibly cooler till we arrive at the poles; in the same manner, the air immediately above the equator cools gradually. Though the temperature sinks as it approaches the pole, and is highest at the equator, yet as it varies continually with the seasons, it is impossible to form an accurate idea of the progression without forming a mean temperature for a year, from that of the temperature of every degree of latitude for every day of the year, which may be accomplished by adding together the whole of the observations and dividing by their number, when the quotient will be the mean temperature for the year. The "diminution," says Dr. Thomson, "from the pole to the equator takes place in arithmetical progression; or to speak more properly, the annual temperature of all the latitudes are arithmetical means between the mean annual temperature of the equator and the pole. And as far as heat depends in the action of solar rays, that of each month is as the mean altitude of the sun, or rather as the sine of the sun's altitude.*

2284. *Inconsiderable seas, in temperate and cold climates, are colder in winter and warmer in summer than the main ocean, as they are necessarily under the influence of natural operations from the land. Thus the Gulf of Bothnia is generally frozen in winter, but the water is sometimes heated in the summer to 70°, a state, the opposite part of the Atlantic never acquires; the German Sea is five degrees warmer in summer than the Atlantic, and more than three colder in winter; the Mediterranean is almost*

throughout warmer both in winter and summer, which therefore causes the Atlantic to flow into it; and the Black Sea being colder than the Mediterranean, flows into the latter.

2285. *The eastern parts of North America*, as appears from meteorological tables, have a much colder air than the opposite European coast, and fall short of the standard by about ten or twelve degrees. There are several causes which produce this considerable difference. The greatest elevation in North America is between the 40th and 50th degree of north latitude, and the 100th and 110th of longitude west from London; and there the most considerable rivers have their origin. The height alone is sufficient to make this tract colder than it would otherwise be; but there are other causes, and those are most extensive forests, and large swamps and morasses, each of which exclude heat from the earth, and consequently prevent it from ameliorating the rigor of winter. Many extensive lakes lie to the east, and Hudson's Bay more to the north; a chain of mountains extends on the south of the latter, and those equally prevent the accumulation of heat; besides, this bay is bounded on the east by the mountainous country of Labrador, and has many islands; from all which circumstances arise the lowness of the temperature, and the piercing cold of the north-west winds. The annual decrease of the forests for the purpose of clearing the ground, and the consumption for building and fuel, is supposed to have occasioned a considerable decrease of cold in the winter; and if this should be the result, much will yet be done towards bringing the temperature of the European and American continents to something like a level.

2286. *Continents* have a colder atmosphere than islands situated in the same degree of latitude; and countries lying to the windward of the superior classes of mountains, or forests, are warmer than those which are to the leeward. Earth always possessing a certain degree of moisture, has a greater capacity to receive and retain heat than sand or stones, the latter therefore are heated and cooled with more rapidity: it is from this circumstance that the intense heats of Africa and Arabia, and the cold of Terra del Fuego, are derived. The temperature of growing vegetables changes very gradually; but there is a considerable evaporation from them: if those exist in great numbers, and congregated, or in forests, their foliage preventing the rays of the sun from reaching the earth, it is perfectly natural that the immediate atmosphere must be greatly affected by the ascent of chilled vapors.

2287. Our next object is *the ascent and descent of water*: the principal appearances of this element are vapor, clouds, dew, rain, frost, hail, snow, and ice.

2288. *Vapor* is water rarefied by heat, in consequence of which becoming lighter than the atmosphere, it is raised considerably above the surface of the earth, and afterwards by a partial condensation forms clouds. It differs from exhalation, which is properly a dispersion of dry particles from a body. When water is heated to 212° it boils, and is rapidly converted into steam; and the same change takes place in much lower temperatures; but in that case the evaporation is slower, and the elasticity of the steam is smaller. As a very considerable proportion of the earth's surface is covered with water, and as this water is constantly evaporating and mixing with the atmosphere in the state of vapor, a precise determination of the rate of evaporation must be of very great importance in meteorology. Evaporation is confined entirely to the surface of the water; hence it is, in all cases, proportional to the surface of the water exposed to the atmosphere. Much more vapor of course rises in maritime countries or those interspersed with lakes, than in inland countries. Much more vapor rises during hot weather than during cold: hence the quantity evaporated depends in some measure upon temperature. The quantity of vapor which rises from water, even when the temperature is the same, varies according to circumstances. It is least of all in calm weather, greater when a breeze blows, and greatest of all with a strong wind. From experiments, it appears, that the quantity of vapor raised annually at Manchester is equal to about 25 inches of rain. If to this we add five inches for the dew, with Dalton, it will make the annual evaporation 30 inches. Now, if we consider the situation of England, and the greater quantity of vapor raised from water, it will not surely be considered as too great an allowance, if we estimate the mean annual evaporation over the whole surface of the globe at 35 inches.

2289. *A cloud* is a mass of vapor, more or less opaque, formed and sustained at considerable height in the atmosphere, probably by the joint agencies of heat and electricity. The first successful attempt to arrange the diversified form of clouds, under a few general modifications, was made by Luke Howard, Esq. We shall give here a brief account of his ingenious classification.

2290. *The simple modifications* are thus named and defined: — 1. Cirrus, parallel, flexuous, or diverging fibres, extensible in any or in all directions (*fig.* 248 *a*); 2. Cumulus, convex or conical heaps, increasing upwards from a horizontal base (*b*); 3. Stratus, a widely-extended, continuous, horizontal sheet, increasing from below (*c*).

2291. *The intermediate modifications* which require to be noticed are, 4. Cirro-cumulus, small, well-defined, roundish masses, in close horizontal arrangement (*d*); 5. Cirro-stratus, horizontal or slightly inclined masses, attenuated towards a part or the whole of their circumference, bent downward or undulated, separate or in groups consisting of small clouds having these characters (*e*).

2292. *The compound modifications* are, 6. Cumulo-stratus, or twain cloud; the cirro-stratus, blended with the cumulus, and either appearing intermixed with the heaps of the



latter, or superadding a wide-spread structure to its base (*f*); 7. Cumulo-cirro-stratus, *vel* Nimbus; the rain-cloud, a cloud or system of clouds from which rain is falling. It is a horizontal sheet, above which the cirrus spreads, while the cumulus enters it laterally and from beneath (*g, g*); 8. The Fall Cloud, resting apparently on the surface of the ground (*h*).

2293. *The cirrus* appears to have the least density, the greatest elevation, the greatest variety of extent and direction, and to appear earliest in serene weather, being indicated by a few threads pencilled on the sky. Before storms they appear lower and denser, and usually in the quarter opposite to that from which the storm arises. Steady high winds are also preceded and attended by cirrous streaks, running quite across the sky in the direction they blow in.

2294. *The cumulus* has the densest structure, is formed in the lower atmosphere, and moves along with the current next the earth. A small irregular spot first appears, and is, as it were, the nucleus on which they increase. The lower surface continues irregularly plane, while the upper rises into conical or hemispherical heaps; which may afterwards continue long nearly of the same bulk, or rapidly rise into mountains. They will begin, in fair weather, to form some hours after sunrise, arrive at their maximum in the hottest part of the afternoon, then go on diminishing, and totally disperse about sunset. Previous to rain the cumulus increases rapidly, appears lower in the atmosphere, and with its surface full of loose fleeces or protuberances. The formation of large cumuli to leeward in a strong wind, indicates the approach of a calm with rain. When they do not disappear or subside about sunset, but continue to rise, thunder is to be expected in the night.

2295. *The stratus* has a mean degree of density, and is the lowest of clouds, its inferior surface commonly resting on the earth in water. This is properly the cloud of night, appearing about sunset. It comprehends all those creeping mists which in calm weather ascend in spreading sheets (like an inundation of water) from the bottoms of valleys, and the surfaces of lakes and rivers. On the return of the sun, the

level surface of this cloud begins to put on the appearance of cumulus, the whole at the same time separating from the ground. The continuity is next destroyed, and the cloud ascends and evaporates, or passes off with the appearance of the nascent cumulus. This has long been experienced as a prognostic of fair weather.

2296. *Transition of forms.* The cirrus having continued for some time increasing or stationary, usually passes either to the cirro-cumulus or the cirro-stratus, at the same time descending to a lower station in the atmosphere. This modification forms a very beautiful sky, and is frequently in summer an attendant on warm and dry weather. The cirro-stratus, when seen in the distance, frequently gives the idea of shoals of fish. It precedes wind and rain; is seen in the intervals of storms; and sometimes alternates with the cirro-cumulus in the same cloud, when the different evolutions form a curious spectacle. A judgment may be formed of the weather likely to ensue by observing which modification prevails at last. The solar and lunar halos, as well as the parhellow and paraselenae (mock sun and mock moon), prognostics of foul weather, are occasioned by this cloud. The cumulo-stratus precedes, and the nimbus accompanies rain.

2297. *Dew* is the moisture insensibly deposited from the atmosphere on the surface of the earth. This moisture is precipitated by the cold of the body on which it appears, and will be more or less abundant, not in proportion to the coldness of that body, but in proportion to the existing state of the air in regard to moisture. It is commonly supposed that the formation of dew produces cold, but like every other precipitation of water from the atmosphere, it must eventually produce heat.

2298. *Phenomena of dew.* Aristotle justly remarked, that dew appears only on calm and clear nights. Dr. Wells shows, that very little is ever deposited in opposite circumstances; and that little only when the clouds are very high. It is never seen on nights both cloudy and windy; and if in the course of the night the weather, from being serene, should become dark and stormy, dew which has been deposited will disappear. In calm weather, if the sky be partially covered with clouds, more dew will appear than if it were entirely uncovered. Dew probably begins in the country to appear upon grass in places shaded from the sun, during clear and calm weather, soon after the heat of the atmosphere has declined, and continues to be deposited through the whole night, and for a little after sunrise. Its quantity will depend in some measure on the proportion of moisture in the atmosphere, and is consequently greater after rain than after a long tract of dry weather; and in Europe, with southerly and westerly winds, than with those which blow from the north and the east. The direction of the sea determines this relation of the winds to dew. For in Egypt, dew is scarcely ever observed except while the northerly or Etesian winds prevail. Hence also, dew is generally more abundant in spring and autumn, than in summer. And it is always very copious on those clear nights which are followed by misty mornings, which show the air to be loaded with moisture. And a clear morning, following a cloudy night, determines a plentiful deposition of the retained vapor. When warmth of atmosphere is compatible with clearness, as is the case in southern latitudes, though seldom in our country, the dew becomes much more copious, because the air then contains more moisture. Dew continues to form with increased copiousness as the night advances, from the increased refrigeration of the ground.

2299. *Cause of dew.* Dew, according to Aristotle, is a species of rain, formed in the lower atmosphere, in consequence of its moisture being condensed by the cold of the night into minute drops. Opinions of this kind, says Dr. Wells, are still entertained by many persons, among whom is the very ingenious Professor Leslie. (*Relat. of Heat and Moisture*, p. 37, and 132.) A fact, however, first taken notice of by Garstin, who published his *Treatise on Dew* in 1773, proves them to be erroneous; for he found, that bodies, a little elevated in the air often become moist with dew, while similar bodies, lying on the ground, remain dry, though necessarily, from their position, liable to be wetted, by whatever falls from the heavens, as the former. The above notion is perfectly refuted by the fact, that metallic surfaces exposed to the air in a horizontal position, remain dry, while every thing around them is covered with dew. After a long period of drought, when the air was very still and the sky serene, Dr. Wells exposed to the sky, 28 minutes before sunset, previously weighed parcels of wool and swandown, upon a smooth, unpainted, and perfectly dry fir table, 5 feet long, 3 broad, and nearly 3 in height, which had been placed, an hour before, in the sunshine, in a large level grassfield. The wool, 12 minutes after sunset, was found to be  $14^{\circ}$  colder than the air, and to have acquired no weight. The swandown, the quantity of which was much greater than that of the wool, was at the same time  $13^{\circ}$  colder than the air, and was also without any additional weight. In 20 minutes more the swandown was  $14^{\circ}$  colder than the neighboring air, and was still without any increase of its weight. At the same time the grass was  $15^{\circ}$  colder than the air four feet above the ground. Dr. Wells, by a copious induction of facts derived from observation and experiment, establishes the proposition, that bodies become colder than the neighboring air before they are dewed. The cold therefore, which Dr. Wilson and M. Six conjectured to be the effect of dew, now appears to be its cause. But what makes the terrestrial surface colder than the atmosphere? The radiation or projection of heat into free space. Now the researches of Professor Leslie and Count Rumford have demonstrated, that different bodies project heat with very different degrees of force. In the operation of this principle, therefore, conjoined with the power of a concave mirror of cloud, or any other awning, to reflect or throw down again those caloric emanations which would be dissipated in a clear sky, we shall find a solution of the most mysterious phenomena of dew.

2300. *Rain.* Luke Howard, who may be considered as our most accurate scientific meteorologist, is inclined to think, that rain is in almost every instance the result of the electrical action of clouds upon each other.

2301. *Phenomena of rain.* Rain never descends till the transparency of the air ceases, and the invisible vapors become vascular, when clouds form, and at length the drops fall: clouds, instead of forming gradually at once throughout all parts of the horizon, generate in a particular spot, and imperceptibly increase till the whole expanse is obscured.

2302. *The cause of rain* is thus accounted for by Dalton. If two masses of air of unequal temperatures, by the ordinary currents of the winds, are intermixed, when saturated with vapor, a precipitation ensues. If the masses are under saturation, then less precipitation takes place, or none at all, according to the degree. Also the warmer the air, the greater is the quantity of vapor precipitated in like circumstances. Hence the reason why rains are heavier in summer than in winter, and in warm countries than in cold.

2303. *The quantity of rain*, taken at an annual mean, is the greatest at the equator, and it lessens gradually to the poles; so there are fewer days of rain there, the number of which increase in proportion to the distance from it. From north latitude  $12^{\circ}$  to  $43^{\circ}$  the mean number of rainy days is 78; from  $43^{\circ}$  to  $46^{\circ}$  the mean number is 103; from  $46^{\circ}$

to 50°, 194; and from 51° to 60°, 161. Winter often produces a greater number of rainy days than summer, though the quantity of rain is more considerable in the latter than in the former season; at Petersburg rain and snow falls on an average 84 days of the winter, and the quantity amounts to about five inches; on the contrary the summer produces eleven inches in about the same number of days. Mountainous districts are subject to great falls of rain; among the Andes particularly, it rains almost incessantly, while the flat country of Egypt is consumed by endless drought. Dalton estimates the quantity of rain falling in England at 31 inches. The mean annual quantity of rain for the whole globe is 34 inches.

2304. *The cause why less rain falls in the first six months of the year than in the last six months is thus explained.* The whole quantity of water in the atmosphere is usually about three inches, as appears from the dew point, which is then about 32°. Now the force of vapors of that temperature is 0.2 of an inch of mercury, which is equal to 2.8 or three inches of water. The dew point in July is usually about 58° or 59°, corresponding to 0.5 of an inch of mercury, which is equal to seven inches of water; the difference is four inches of water, which the atmosphere then contains more than in the former month. Hence, supposing the usual intermixture of currents of air in both the intervening periods to be the same, the rain ought to be four inches less in the former period of the year than the average, and four inches more in the latter period, making a difference of eight inches between the two periods, which nearly accords with the preceding observations.

2305. *The mean monthly and annual quantities of rain at various places, deduced from the average for many years, by Dalton, is given in the following Table.*

	Manchester, 33 years.	Liverpool, 18 years.	Chatsworth, 16 years.	Lancaster, 20 years.	Kendal, 25 years.	Dumfries, 16 years.	Glasgow, 17 years.	London, 40 years.	Paris, 15 years.	Viviers, 40 years.	General Average.
	Inch.	Inch.	Inch.	Inch.	Inch.	Inch.	Inch.	Inch.	Fr. In.	Fr. In.	Inch.
January -	2.310	2.177	2.196	3.461	5.299	3.095	1.595	1.464	1.223	2.477	2.530
February -	2.568	1.847	1.652	2.995	5.126	2.837	1.741	1.250	1.232	1.700	2.295
March - -	2.098	1.523	1.322	1.753	3.151	2.164	1.184	1.172	1.190	1.927	1.748
April - -	2.010	2.104	2.078	2.180	2.986	2.017	0.979	1.279	1.185	2.686	1.950
May - - -	2.895	2.573	2.118	2.460	3.480	2.568	1.641	1.636	1.767	2.931	2.407
June - - -	2.502	2.816	2.286	2.512	2.722	2.374	1.343	1.738	1.697	2.562	2.315
July - - -	3.697	3.663	3.006	4.140	4.959	3.256	2.303	2.448	1.800	1.882	3.115
August - -	3.665	3.311	2.435	4.581	5.089	3.199	2.746	1.807	1.900	2.347	3.103
September -	3.281	3.654	2.289	3.751	4.874	4.350	1.617	1.842	1.550	4.140	3.135
October - -	3.922	3.724	3.079	4.151	5.439	4.143	2.297	2.092	1.780	4.741	3.557
November -	3.360	3.441	2.634	3.775	4.785	3.174	1.904	2.222	1.720	4.187	3.120
December -	3.832	3.288	2.569	3.955	6.084	3.142	1.981	1.736	1.600	2.397	3.058
	36.140	34.121	27.664	39.714	53.944	36.919	21.331	20.686	18.649	33.977	

2306. *Frost, being derived from the atmosphere, naturally proceeds from the upper parts of bodies downward, as the water and the earth; so the longer a frost is continued, the thicker the ice becomes upon the water in ponds, and the deeper into the earth the ground is frozen.* In about 16 or 17 days' frost, Boyle found it had penetrated 14 inches into the ground. At Moscow, in a hard season, the frost will penetrate two feet deep into the ground; and Captain James found it penetrated 10 feet deep in Charlton island, and the water in the same island was frozen to the depth of six feet. Scheffer assures us, that in Sweden the frost pierces two cubits (a Swedish ell), into the earth, and turns what moisture is found there into a whitish substance, like ice; and standing water to three ells or more. The same author also mentions sudden cracks or rifts in the ice of the lakes of Sweden, nine or ten feet deep, and many leagues long; the rupture being made with a noise not less loud than if many guns were discharged together. By such means however the fishes are furnished with air, so that they are rarely found dead.

2307. *The history of frosts furnishes very extraordinary facts.* The trees are often scorched and burnt up, as with the most excessive heat, in consequence of the separation of water from the air, which is therefore very drying. In the great frost in 1683, the trunks of oak, ash, walnut, and other trees, were miserably split and cleft, so that they might be seen through, and the cracks often attended with dreadful noises like the explosion of fire-arms.

2308. *Hail is generally defined as frozen rain, it differs from it in that the hailstones are not formed of single pieces of ice, but of many little spherules agglutinated together; neither are those spherules all of the same consistence; some of them being hard and solid, like perfect ice; others soft, and mostly like snow hardened by a severe frost.* Hailstone has a kind of core of this soft matter; but more frequently the core is solid and hard, while the outside is formed of a softer matter. Hailstones assume various figures, being sometimes round, at other times pyramidal, crenated, angular, thin, and flat, and sometimes stellated with six radii, like the small crystals of snow. Natural historians furnish us with various accounts of surprising showers of hail in which the hailstones were of extraordinary magnitude.

2309. *Snow* is formed by the freezing of the vapors in the atmosphere. It differs from hail and hoar frost, in being as it were crystallised, which they are not. As the flakes fall down through the atmosphere, they are continually joined by more of these radiated spicula, and they increase in bulk like the drops of rain or hailstones. The lightness of snow, although it is firm ice, is owing to the excess of its surface in comparison to the matter contained under it: as gold itself may be extended in surface till it will ride upon the least breath of air. The whiteness of snow is owing to the small particles into which it is divided; for ice when pounded will become equally white.

2310. *Snow is of great use to the vegetable kingdom.* Were we to judge from appearance only, we might imagine, that so far from being useful to the earth, the cold humidity of snow would be detrimental to vegetation. But the experience of all ages asserts the contrary. Snow, particularly in those northern regions where the ground is covered with it for several months, fructifies the earth, by guarding the corn or other vegetables from the intenser cold of the air, and especially from the cold piercing winds. It has been a vulgar opinion, very generally received, that snow fertilises the land on which it falls more than rain, in consequence of the nitrous salts which it is supposed to acquire by freezing. But it appears from the experiments of Margraaf, in the year 1731, that the chemical difference between rain and snow-water, is exceedingly small; that the latter contains a somewhat less proportion of earth than the former; but neither of them contain either earth, or any kind of salt, in any quantity which can be sensibly efficacious in promoting vegetation. The peculiar agency of snow as a fertiliser, in preference to rain, may be ascribed to its furnishing a covering to the roots of vegetables, by which they are guarded from the influence of the atmospherical cold, and the internal heat of the earth is prevented from escaping. The internal parts of the earth are heated uniformly to the fifty-eighth degree of Fahrenheit's thermometer. This degree of heat is greater than that in which the watery juices of vegetables freeze, and it is propagated from the inward parts of the earth to the surface, on which the vegetables grow. The atmosphere, being variably heated by the action of the sun in different climates, and in the same climate at different seasons, communicates to the surface of the earth, and to some distance below it, the degree of heat and cold which prevails in itself. Different vegetables are able to preserve life under different degrees of cold, but all of them perish when the cold which reaches their roots is extreme. Providence has, therefore, in the coldest climates, provided a covering of snow for the roots of vegetables, by which they are protected from the influence of the atmospherical cold. The snow keeps in the internal heat of the earth, which surrounds the roots of vegetables, and defends them from the cold of the atmosphere.

2311. *Ice* is water in the solid state, during which the temperature remains constant, being 32 degrees of the scale of Fahrenheit. Ice is considerably lighter than water, namely, about one-eighth part; and this increase of dimensions is acquired with prodigious force, sufficient to burst the strongest iron vessels, and even pieces of artillery. Congelation takes place much more suddenly than the opposite process of liquefaction; and of course, the same quantity of heat must be more rapidly extricated in freezing than it is absorbed in thawing; the heat thus extricated being disposed to fly off in all directions, and little of it being retained by the neighboring bodies, more heat is lost than is gained by the alternation: so that where ice has once been formed, its production is in this manner redoubled.

2312. *The northern ice* extends about 9° from the pole; the southern 18° or 20°; in some parts even 30°; and floating ice has occasionally been found in both hemispheres as far as 40° from the poles, and sometimes, as it has been said, even in latitude 41° or 42°. Between 54° and 60° south latitude, the snow lies on the ground, at the sea-side, throughout the summer. The line of perpetual congelation is three miles above the surface at the equator, where the mean heat is 84°; at Teneriffe, in latitude 28°, two miles; in the latitude of London, a little more than a mile; and in latitude 80° north, only 1250 feet. At the pole, according to the analogy deduced by Kirwan, from a comparison of various observations, the mean temperature should be 31°. In London the mean temperature is 50°; at Rome and at Montpellier, a little more than 60°; in the island of Madeira, 70°; and in Jamaica, 80°.

2313. *Wind.* Were it not for this agitation of the air, putrid effluvia arising from the habitations of man, and from vegetable substances, besides the exhalations from water, would soon render it unfit for respiration, and a general mortality would be the consequence. The prevailing winds of our own country, which were ascertained by order of the Royal Society of London, at London, are,

Winds.	Days.	Winds.	Days.	Winds.	Days.
South-west	- 112	West	- 53	South	- 18
North-east	- 58	South-east	- 32	North	- 16
North-west	- 50	East	- 26		

The south wind blows more upon an average in each month of the year than any other,

particularly in July and August; the north-east prevails during January, March, April, May, and June, and is most infrequent in February, July, September, and December; the north-west occurring more frequently from November to March, and less so in September and October than in any other months.

2314. *Near Glasgow*, the average is stated as follows:—

Winds.		Days.	Winds.		Days.
South-west	-	17½	North-east	-	104
North-west	-	40	South-east	-	47

2315. *In Ireland*, the prevailing winds are the west and south-west.

2316. *The different degrees of motion of wind* next excite our attention; and it seems almost superfluous to observe, that it varies in gradations from the gentlest zephyr, which plays upon the leaves of plants, greatly undulating them, to the furious tempest, calculated to inspire horror in the breast of the most callous. It is also a remarkable fact, that violent currents of air pass along, as it were, within a line, without sensibly agitating that beyond them. An instance of this kind occurred at Edinburgh, where the celebrated aeronaut Lunardi ascended in his balloon, which was conveyed with great velocity by the wind at the rate of 70 miles an hour, while a perfect calm existed in the city and neighborhood.

2317. *Causes of wind.* There are many circumstances attending the operations of the air, which we term wind, that serve for a basis for well-founded conjectures, and those, united to the result of daily observation, render the explanation of its phenomena tolerably satisfactory. It must be clear to the most common capacity, that as the rays of the sun descend perpendicularly on the surface of the earth under the torrid zone, that part of it must receive a greater proportion of heat than those parts where they fall obliquely; the heat thus acquired communicates to the air, which it rarefies, and causes to ascend, and the vacuum occasioned by this operation is immediately filled by the chill air from the north and south. The diurnal motion of the earth gradually lessens to the poles from the equator: at that point it moves at the rate of fifteen geographical miles in a minute: this motion is communicated to the atmosphere in the same degree; therefore, if part of it was conveyed instantaneously from latitude 30°, it would not directly acquire the velocity of that at the equator; consequently, the ridges of the earth must meet it, and give it the appearance of an east wind; the effect is similar upon the cold air proceeding from the north and south, and this similarity must be admitted to extend to each place particularly heated by the beams of the sun. The moon, being a large body situated comparatively near the earth, is known to affect the atmosphere in its revolutions by the pressure of that upon the sea, so as to cause the flux and reflux of it, which we term tides; it cannot, therefore, be doubted, that some of the winds we experience are caused by her motion.

2318. *The regular motion of the atmosphere*, known by the name of *land and sea breezes*, may be accounted for upon the above principle: the heated rarefied land air rises, and its place is supplied by the chill damp air from the surface of the sea; that from the hills in the neighborhood, becoming cold and dense in the course of the night, descends and presses upon the comparatively lighter air over the sea, and hence the land breeze. Granting that the attraction of the moon, and the diurnal movement of the sun affects our atmosphere, there cannot be a doubt but a westward motion of the air must prevail within the boundaries of the trade-winds, the consequence of which is an easterly current on each side: from this, then, it proceeds that south-west winds are so frequent in the western parts of Europe, and over the Atlantic Ocean. Kirwan attributes our constant south-west winds, particularly during winter, to an opposite current prevailing between the coast of Malabar and the Moluccas at the same period: this, he adds, must be supplied from regions close to the pole, which must be recruited in its turn from the countries to the south of it, in the western parts of our hemisphere.

2319. *The variable winds* cannot be so readily accounted for; yet it is evident, that though they seem the effect of capricious causes, they depend upon a regular system, arranged by the great Author of nature. That accurate and successful observer of part of his works, the celebrated Franklin, discovered in 1740, that winds originate at the precise points towards which they blow. This philosopher had hoped to observe an eclipse of the moon at Philadelphia, but was prevented by a north-east storm, that commenced at seven in the evening. This he afterwards found did not occur at Boston till eleven; and upon enquiry, he had reason to suppose, it passed to the north-east at the rate of about 100 miles an hour. The manner in which he accounts for this retrograde proceeding, is so satisfactory, that we shall give it in his own words, particularly as his assertions are supported by recent observations, both in America and Scotland. He argued thus:—"I suppose a long canal of water, stopped at the end by a gate. The water is at rest till the gate is opened; then it begins to move out through the gate, and the water next the gate is put in motion and moves on towards the gate; and so on successively, till the water at the head of the canal is in motion, which it is last of all. In this case all the water moves indeed towards the gate; but the successive times of beginning the motion are in the contrary way, viz. from the gate back to the head of the canal. Thus to produce a north-east storm, I suppose some great rarefaction of the air in or near the Gulph of Mexico; the air rising thence has its place supplied by the next more northern, cooler, and therefore denser and heavier air; a successive current is formed, to which our coast and inland mountains give a north-east direction." According to the observations made by Captain Cook, the north-east winds prevail in the Northern Pacific Ocean during the same spring months they do with us, from which facts it appears the cold air from America and the north of Europe flows at that season into the Pacific and Atlantic Oceans.

2320. *Other descriptions of winds* may arise from a variety of causes. As the atmosphere has been ascertained to be composed of air, vapor, and carbonic acid and water, it is well known these frequently change their aerial form, and combine with different substances, and the reverse; consequently partial winds and accumulations must continually occur, which occasion winds of different degrees of violence, continuance, and direction.

2321. *The principal electrical phenomena of the atmosphere* are thunder and lightning.

2322. *Thunder* is the noise occasioned by the explosion of a flash of lightning passing through the air: or it is that noise which is excited by a sudden explosion of electrical clouds, which are therefore called thunder-clouds.

2323. *The rattling*, in the noise of thunder, which makes it seem as if it passed through arches, is probably owing to the sound being excited among clouds hanging over one another, and the agitated air passing irregularly between them.

2324. *The explosion*, if high in the air and remote from us, will do no mischief; but when near, it may, and has, in a thousand instances, destroyed trees, animals, &c. This proximity, or small distance, may be estimated nearly by the interval of time between seeing the flash of lightning and hearing the report of the thunder, estimating the distance after the rate of 1142 feet for a second of time, or  $3\frac{1}{2}$  seconds to the mile. Dr. Wallis observes, that commonly the difference between the two is about seven seconds, which at the rate above-mentioned, gives the distance almost two miles. But sometimes it comes in a second or two, which argues the explosion very near to us, and even among us. And in such cases, the Doctor assures us, he has sometimes foretold the mischiefs that happened.

2325. *Season of thunder*. Although in this country thunder may happen at any time of the year, yet the months of July and August are those in which it may almost certainly be expected. Its devastations is of very uncertain continuance; sometimes only a few peals will be heard at any particular place during the whole season; at other times the storm will return at the interval of three or four days, for a month, six weeks, or even longer; not that we have violent thunder in this country directly vertical in any one place so frequently in any year, but in many seasons it will be perceptible that thunder-clouds are formed in the neighborhood, even at these short intervals. Hence it appears, that during this particular period, there must be some natural cause operating for the production of this phenomenon, which does not take place at other times. This cannot be the mere heat of the weather, for we have often a long tract of hot weather without any thunder; and besides, though not common, thunder is sometimes heard in the winter also. As therefore the heat of the weather is common to the whole summer, whether there be thunder or not, we must look for the causes of it in those phenomena, whatever they are, which are peculiar to the months of July, August, and the beginning of September. Now it is generally observed, that from the month of April, an east, or south-east wind generally takes place, and continues with little interruption till towards the end of June. At that time, sometimes sooner and sometimes later, a westerly wind takes place; but as the causes producing the east wind are not removed, the latter opposes the west wind with its whole force. At the place of meeting, there is naturally a most vehement pressure of the atmosphere, and friction of its parts against one another; a calm ensues, and the vapors brought by both winds begin to collect and form dark clouds, which can have little motion either way, because they are pressed almost equally on all sides. For the most part, however, the west wind prevails, and what little motion the clouds have is towards the east: whence, the common remark in this country, that "thunder-clouds move against the wind." But this is by no means universally true: for if the west wind happens to be excited by any temporary cause before its natural period when it should take place, the east wind will very frequently get the better of it; and the clouds, even although thunder is produced, will move westward. Yet in either case the motion is so slow, that the most superficial observers cannot help taking notice of a considerable resistance in the atmosphere.

2326. *Thunderbolts*. When lightning acts with extraordinary violence, and breaks or shatters any thing it is called a thunderbolt, which the vulgar, to fit it for such effects, suppose to be a hard body, and even a stone. But that we need not to have recourse to a hard solid body to account for the effects commonly attributed to the thunderbolt, will be evident to any one, who considers those of gunpowder, and the several chemical fulminating powders, but more especially the astonishing powers of elasticity, when only collected and employed by human art, and much more when directed and exercised in the course of nature. When we consider the known effects of electrical explosions, and those produced by lightning, we shall be at no loss to account for the extraordinary operations vulgarly ascribed to thunderbolts. As stones and bricks struck by lightning are often found in a vitrified state, we may reasonably suppose, with Beccaria, that some stones in the earth, having been struck in this manner, gave occasion to the vulgar opinion of the thunderbolt.

2327. *Thunder-clouds* are those clouds which are in a state fit for producing lightning and thunder. The first appearance of a thunder-storm, which usually happens when there is little or no wind, is one dense cloud, or more, increasing very fast in size, and rising into the higher regions of the air. The lower surface is black, and nearly level; but the upper finely arched, and well defined. Many of these clouds often seem piled upon one another, all arched in the same manner; but they are continually uniting, swelling, and extending their arches. At the time of the rising of this cloud, the atmosphere is commonly full of a great many separate clouds, that are motionless, and of odd whimsical shapes; all these, upon the appearance of the thunder-cloud, draw towards it, and become more uniform in their shapes as they approach; till, coming very near the thunder-cloud, their limbs mutually stretch towards one another, and they immediately coalesce into one uniform mass. Sometimes the thunder-cloud will swell, and increase very fast, without the conjunction of any adscititious clouds; the vapors in the atmosphere forming themselves into clouds whenever it passes. Some of the adscititious clouds appear like white fringes, at the skirts of the thunder-cloud, or under the body of it; but they keep continually growing darker and darker, as they approach to unite with it. When the thunder-cloud is grown to a great size, its lower surface is often ragged, particular parts being detached towards the earth, but still connected with the rest. Sometimes the lower surface swells into various large protuberances, bending uniformly downward; and sometimes one whole side of the cloud will have an inclination to the earth, and the extremity of it nearly touch the ground. When the eye is under the thunder-cloud, after it is grown large and well-formed, it is seen to sink lower, and to darken prodigiously; at the same time that a number of small adscititious clouds (the origin of which can never be perceived) are seen in a rapid motion, driving about in very uncertain directions under it. While these clouds are agitated with the most rapid motions, the rain commonly falls in the greatest plenty; and if the agitation be exceedingly great, it commonly hails.

2328. *Lightning*. While the thunder-cloud is swelling, and extending its branches over a large tract of country, the lightning is seen to dart from one part of it to another, and often to illuminate its whole mass. When the cloud has acquired a sufficient extent, the lightning strikes between the cloud and the earth, in two opposite places; the path of the lightning lying through the whole body of the cloud and its branches. The longer this lightning continues, the less dense does the cloud become, and the less dark its appearance; till at length it breaks in different places, and shows a clear sky. Those thunder-clouds are sometimes in a positive as well as a negative state of electricity. The electricity continues longer of the same kind, in proportion as the thunder-cloud is simple and uniform in its direction; but when the lightning changes its place, there commonly happens a change in the electricity of the apparatus over which the clouds passed. It changes suddenly after a very violent flash of lightning; but gradually when the lightning is moderate, and the progress of the thunder-cloud slow.

2329. *Lightning is an electrical explosion or phenomenon*. Flashes of lightning are usually seen crooked and waving in the air. They strike the highest and most pointed objects in preference to others, as hills, trees, spires, masts of ships, &c.; so all pointed conductors receive and throw off the electric fluid more readily than those that are terminated by flat surfaces. Lightning is observed to take and follow the readiest and best conductor; and the same is the case with electricity in the discharge of the Leyden phial; from whence it is inferred, that in a thunder-storm it would be safer to have one's clothes wet than dry. Lightning burns, dissolves metals, rends some bodies, sometimes strikes persons blind, destroys ani-



mal life, deprives magnets of their virtue, or reverses their poles; and all these are well known properties of electricity.

2330. *With regard to places of safety in times of thunder and lightning.* Dr. Franklin's advice is to sit in the middle of a room, provided it be not under a metal lustre suspended by a chain, sitting on one chair, and laying the feet on another. It is still better, he says, to bring two or three mattresses or beds into the middle of the room, and folding them double, to place the chairs upon them; for as they are not so good conductors as the walls the lightning will not be so likely to pass through them. But the safest place of all is in a hammock hung by silken cords, at an equal distance from all the sides of the room. Dr. Priestley observes, that the place of most perfect safety must be the cellar, and especially the middle of it; for when a person is lower than the surface of the earth, the lightning must strike it before it can possibly reach him. In the fields, the place of safety is within a few yards of a tree, but not quite near it. Beccaria cautions persons not always to trust too much to the neighborhood of a higher or better conductor than their own body, since he has repeatedly found that the lightning by no means descends in one undivided track, but that bodies of various kinds conduct their share of it at the same time, in proportion to their quantity and conducting power.

## SECT. II. *Of the Means of prognosticating the Weather.*

2331. *The study of atmospheric changes* has, in all ages, been more or less attended to by men engaged in the culture of vegetables, or the pasturage of animals; and we, in this country, are surprised at the degree of perfection to which the ancients attained in this knowledge. But it ought to be recollected, that the study of the weather in the countries occupied by the ancients, as Egypt, Greece, Italy, and the continent of Europe, is a very different thing from its study in an island situated like ours. It is easy to foretell weather in countries where months pass away without rain or clouds, and where some weeks together, at stated periods, are as certainly seasons of rain or snow. It may be asserted with truth, that there is a greater variety of weather in London in one week, than in Rome, Moscow, or Petersburgh, in three months. It is not, therefore, entirely a proof of our degeneracy, or the influence of our artificial mode of living, that we cannot predict the weather with such certainty as the ancients; but a circumstance rather to be accounted for from the peculiarities of our situation.

2332. *A variable climate, such as ours,* admits of being studied, both generally and locally; but it is a study which requires habits of observation and reflection like all other studies; and to be brought to any useful degree of perfection must be attended to, not as it commonly is, as a thing by chance, and which every body knows, or is fit for, but as a serious undertaking. The weather may be foretold from natural data, artificial data, and from precedent.

2333. *The natural data* for this study are, 1. The vegetable kingdom; many plants shutting and opening their flowers, contracting or expanding their parts, &c. on approaching changes in the humidity or temperature of the atmosphere; 2. The animal kingdom; most of which, that are familiar to us, exhibiting signs on approaching changes, of which those by cattle and sheep are more especially remarkable; and hence shepherds are generally, of all others, the most correct in their estimate of weather; 3. The mineral kingdom; stones, earths, metals, salts, and water of particular sorts, often showing indications of approaching changes; 4. Appearances of the atmosphere, the moon, the general character of seasons, &c. The characters of clouds, the prevalence of particular winds, and other signs are very commonly attended to.

2334. *The influence of the moon on the weather* has, in all ages, been believed by the generality of mankind: the same opinion was embraced by the ancient philosophers; and several eminent philosophers of later times have thought the opinion not unworthy of notice. Although the moon only acts (as far at least as we can ascertain) on the waters of the ocean by producing tides, it is nevertheless highly *probable*, according to the observations of Lambert, Toaldo, and Cotte, that in consequence of the lunar influence, great variations do take place in the atmosphere, and consequently in the weather. The following principles will show the grounds and reasons for their embracing the received notions on this interesting topic: —

2335. *There are ten situations in the moon's orbit* when she must particularly exert her influence on the atmosphere; and when, consequently, changes of the weather most readily take place. These are, —

1. The *new*, and 2. the *full* moon, when she exerts her influence in conjunction with, or in opposition to the sun.

3. and 4. The *quadratures*, or those aspects of the moon when she is 90° distant from the sun; or when she is in the middle point of her orbit, between the points of conjunction and opposition, namely, in the first and third quarters.

5. The *perigee*, and 6. The *apogee*, or those points of the moon's orbit, in which she is at the *least* and *greatest* distance from the earth.

7. 8. The two passages of the moon over the equator, one of which Toaldo calls, 7. The moon's *ascending*, and the other, 8. The moon's *descending* equinox, or the two *lunistics*, as De la Lande terms them.

9. The *boreal lunistic*, when the moon approaches as near as she can in each lunation, (or period between one new moon and another,) to our zenith (that point in the horizon which is directly over our heads).

10. The *austral lunistic*, when she is at the greatest distance from our zenith; for the action of the moon varies greatly according to her obliquity. With these ten points Toaldo compared a table of forty-eight years' observations; the result is, that the probabilities, that the weather will change at a certain period of the moon, are in the following proportions: New moon, 6 to 1. First quarter, 5 to 2. Full moon, 5 to 2. Last quarter, 5 to 4. Perigee, 7 to 1. Apogee, 4 to 1. Ascending equinox, 13 to 4. Northern lunistic, 11 to 4. Descending equinox, 11 to 4. Southern lunistic, 3 to 1.

2336. *That the new moon will bring with it a change of weather* is in the doctrine of chances as 6 to 1. Each situation of the moon alters that state of the atmosphere which has been occasioned by the preceding one: and it seldom happens that any change in the weather takes place without a change in the lunar

situations. These situations are combined, on account of the inequality of their revolutions, and the greatest effect is produced by the union of the syzgies, or the conjunction and opposition of a planet with the sun, with the apses, or points in the orbits of planets, in which they are at the greatest and least distance from the sun or earth. The proportions of their powers to produce variations are as follows; New moon coinciding with the perigee, 33 to 1. Ditto, with the apogee, 7 to 1. Full moon coinciding with the perigee, 10 to 1. Ditto, with the apogee, 8 to 1. The combination of these situations generally occasions storms and tempests; and this perturbing power will always have the greater effect, the nearer these combined situations are to the moon's passage over the equator, particularly in the months of March and September. At the new and full moons, in the months of March and September, and even at the solstices, especially the winter solstice, the atmosphere assumes a certain character, by which it is distinguished for three, and sometimes six months. The new moons which produce no change in the weather, are those that happen at a distance from the apses. As it is perfectly true that each situation of the moon alters that state of the atmosphere which has been produced by another, it is, however, observed, that many situations of the moon are favorable to good and others to bad weather.

2337. *The situations of the moon favorable to bad weather* are the perigee, new and full moon, passage of the equator, and the northern lunistic. Those belonging to the former are, the apogee, quadratures, and the southern lunistic. Changes of the weather seldom take place on the very days of the moon's situations, but either precede or follow them. It has been found by observation, that the changes affected by the lunar situations in the six winter months precede, and in the six summer months follow them.

2338. *The octants.* Besides the lunar situations to which the above observations refer, attention must be paid also to the fourth day before new and full moon, which days are called the octants. At these times the weather is inclined to changes; and it may be easily seen, that these will follow at the next lunar situation. Virgil calls this fourth day a very sure prophet. If on that day the horns of the moon are clear and well defined, good weather may be expected; but if they are dull, and not clearly marked on the edges, it is a sign that bad weather will ensue. When the weather remains unchanged on the fourth, fifth, and sixth day of the moon, we may conjecture that it will continue so till full moon, even sometimes till the next new moon; and in that case, the lunar situations have only a very weak effect. Many observers of nature have also remarked, that the approach of the lunar situations is somewhat critical for the sick. According to Dr. Herschel, the nearer the time of the moon's entrance, at full, change, or quarters, is to midnight (that is within two hours before and after midnight), the more fair the weather is in summer, but the nearer to noon the less fair. Also, the moon's entrance, at full, change, or quarters, during six of the afternoon hours, viz. from four to ten, may be followed by fair weather; but this is mostly dependent on the wind. The same entrance during all the hours after midnight, except the two first, is unfavorable to fair weather; the like, nearly, may be observed in winter.

2339. *The artificial data* are the barometer, hygrometer, rain-gauge, and thermometer.

2340. By means of the barometer, Taylor observes, we are enabled to regain, in some degree at least, that foreknowledge of the weather, which the ancients unquestionably did possess; though we know not the data on which they founded their conclusions. Chaptal considers that the value of the barometer as an indicator of the approaching weather, is greater than that of the lunar knowledge of the most experienced countryman, and indeed of all other means put together. (*Agriculture appliqué à Chimie, &c.*) We shall therefore annex such rules as have hitherto been found most useful in ascertaining the changes of the weather, by means of the barometer.

2341. *The rising of the mercury* presages, in general, fair weather; and its falling foul weather, as rain, snow, high winds, and storms.

2342. *The sudden falling of the mercury* foretels thunder, in very hot weather, especially if the wind is south.

2343. *The rising in winter* indicates frost; and in frosty weather, if the mercury falls three or four divisions, there will follow a thaw: but if it rises in a continued frost, snow may be expected.

2344. *When foul weather happens soon after the falling of the mercury* it will not be of long duration; nor are we to expect a continuance of fair weather, when it soon succeeds the rising of the quicksilver.

2345. *If, in foul weather, the mercury rises* considerably, and continues rising for two or three days before the foul weather is over, a continuance of fair weather may be expected to follow.

2346. *When foul weather happens soon after the falling of the mercury*, it will not be of long duration; nor are we to expect a continuance of fair weather, when it soon succeeds the rising of the quicksilver.

2347. *If, in foul weather, the mercury rises* considerably, and continues rising for two or three days before the foul weather is over, a continuance of fair weather may be expected to follow.

2348. *In fair weather, when the mercury falls* much and low, and continues falling for two or three days before rain comes, much wet must be expected, and probably high winds.

2349. *The unsettled motion of the mercury* indicates changeable weather.

2350. *Respecting the words engraved on the register-plate of the barometer*, it may be observed, that they cannot be strictly relied upon to correspond exactly with the state of the weather; though it will in general agree with them as to the mercury rising and falling. The words deserve to be particularly noticed when the mercury moves from 'changeable' upwards; as those on the lower part should be adverted to, when the mercury falls from 'changeable' downwards. In other cases, they are of no use: for, as its rising in any part forebodes a tendency to fair, and its falling to foul weather, it follows that, though it descend in the tube from settled to fair, it may nevertheless be attended with a little rain, and when it rises from the words 'much rain' to 'rain' it shows only an inclination to become fair, though the wet weather may still continue in a less considerable degree than it was when the mercury began to rise. But if the mercury, after having fallen to 'much rain,' should ascend to 'changeable,' it foretels fair weather, though of a shorter continuance than if the mercury had risen still higher; and so, on the contrary, if the mercury stood at 'fair' and descends to 'changeable,' it announces foul weather, though not of so long continuance, as if it had fallen lower.

2351. *Concavity of the surface of the mercury.* Persons who have occasion to travel much in the winter, and who are doubtful whether it will rain or not, may easily ascer-

tain this point by the following observation : — A few hours before he departs, let the traveller notice the mercury in the upper part of the tube of the barometer ; if rain is about to fall, it will be indented, or concave ; if otherwise, convex or protuberant.

2352. *Barometer in spring.* Towards the end of March, or more generally in the beginning of April, the barometer sinks very low, with bad weather ; after which, it seldom falls lower than 29 degrees 5 minutes till the latter end of September or October, when the quicksilver falls again low, with stormy winds, for then the winter constitution of the air takes place. From October to April, the great falls of the barometer are from 29 degrees 5 minutes to 28 degrees 5 minutes, and sometimes lower ; whereas during the summer constitution of the air, the quicksilver seldom falls lower than 29 degrees 5 minutes. It therefore follows that a fall of one tenth of an inch, during the summer, is as sure an indication of rain, as a fall of between two and three tenths is in the winter.

2353. *Barometer relative to situation.* It must, however, be observed, that these heights of the barometer hold only in places nearly on a level with the sea ; for experiments have taught us, that for every eighty feet of nearly perpendicular height that the barometer is placed above the level of the sea, the quicksilver sinks one tenth of an inch : observations alone, therefore, must determine the heights of the quicksilver, which in each place denotes either fair or foul weather.

2354. *The hygrometer* is of various sorts, but cord, fiddle-string, and most of the substances commonly used become sensibly less and less accurate, so as at length not to undergo any visible alteration from the different states of the air, in regard to dryness or moisture.

2355. *A sponge makes a good hygrometer* on this account, as being less liable to be changed by use than cord. To prepare the sponge, first wash it in water, and when dry, wash it again in water wherein sal ammoniac or salt of tartar has been dissolved ; and let it dry again. Now, if the air becomes moist, the sponge will grow heavier ; and if dry, it will become lighter.

2356. *Oil of vitriol* is found to grow sensibly lighter or heavier in proportion to the lesser or greater quantity of moisture it imbibes from the air. The alteration is so great, that it has been known to change its weight from three drachms to nine. The other acid oils, or, as they are usually called, spirits, or oil of tartar *per deliquium*, may be substituted for the oil of vitriol.

2357. *Steel-yard hygrometer.* In order to make a hygrometer with those bodies which acquire or lose weight in the air, place such a substance in a scale on the end of a steel-yard, with a counterpoise which shall keep it *in equilibrio* in fair weather ; the other end of the steel-yard, rising or falling, and pointing to a graduated index, will shew the changes.

2358. *Line and plummet.* If a line be made of good well dried whip cord, and a plummet be fixed to the end of it, and the whole be hung against a wainscot, and a line be drawn under it, exactly where the plummet reaches, in very moderate weather it will be found to rise above such line, and to sink below it when the weather is likely to become fair.

2359. *The whalebone hygrometer*, originally invented by De Luc, is esteemed one of the best now in use.

2360. *The rain-gauge, pluviometer, or hyetometer*, is a machine for measuring the quantity of rain that falls.

2361. *A hollow cylinder* forms one of the best-constructed rain gauges : it has within it a cork ball attached to a wooden stem (fig. 249.), which passes through a small opening at the top, on which is placed a large funnel. When this instrument is placed in the open air in a free place, the rain that falls within the circumference of the funnel will run down into the tube and cause the cork to float ; and the quantity of water in the tube may be seen by the height to which the stem of the float is raised. The stem of the float is so graduated, as to show by its divisions the number of perpendicular inches of water which fell on the surface of the earth since the last observation. After every observation the cylinder must be emptied.

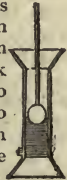

2362. *A copper funnel* forms another very simple rain-gauge : the area of the opening must be exactly ten square inches. Let this funnel be fixed in a bottle, and the quantity of rain caught is ascertained by multiplying the weight in ounces by 173, which gives the depth in inches and parts of an inch.

2363. *In fixing these gauges*, care must be taken that the rain may have free access to them ; hence the tops of buildings are usually the best places, though some conceive that the nearer the rain-gauge is placed to the ground the more rain it will collect.

2364. In order to compare the quantities of rain collected in pluviometers at different places, the instruments should be fixed at the same heights above the ground in all such places; because, at different heights, the quantities are always different, even at the same place.

2365. *Thermometer.* As the weight of the atmosphere is measured by the barometer, so the thermometer shows the variations in the temperature of the weather; for every change of the weather is attended with a change in the temperature of the air, which a thermometer placed in the open air will point out, sometimes before any alteration is perceived in the barometer.

2366. *The scales of different thermometers are as follow.* In Fahrenheit's the freezing point is 32 degrees, and the boiling point 212 degrees. In Reaumur's the freezing point is 0, and the boiling point 80 degrees. In the centigrade thermometer, which is generally used in France, and is the same as that of Celsiusus, which is the thermometer of Sweden, the freezing point is 0, and the boiling point 100 degrees. As a rule for comparing or reducing these scales, it may be stated, that 1 degree of Reaumur's scale contains  $\frac{24}{5}$  degrees of Fahrenheit, and to convert the degrees of the one to the other, the rule is to multiply by 9, divide by 5, and add 32. One degree of the centigrade scale is equal to one degree and eight-tenths of Fahrenheit; and the rule here is to multiply by 9, divide by 5, and add 32. Any of these thermometers may be proved by immersing it in pounded ice for the freezing point, and in boiling water for the boiling point, and if the space between these points is equally divided, the thermometer is correct.

2367. *The study of the weather from precedent, affords useful hints as to the character of approaching seasons.* From observing the general character of seasons for a long period, certain general results may be deduced. On this principle, Kirwan, on comparing a number of observations taken in England from 1677 (*Trans. Ir. Acad.* v. 20.) to 1789, a period of 112 years, found:

That when there has been *no storm before or after the vernal equinox*, the ensuing summer is generally dry, at least five times in six.

That *when a storm happens from an easterly point*, either on the 19th, 20th, or 21st of May, the succeeding summer is generally dry, at least four times in five.

That *when a storm arises on the 25th, 26th, or 27th of March*, and not before in any point, the succeeding summer is generally dry, four times in five.

If there be a storm at S. W. or W. S. W. on the 19th, 20th, 21st, or 22d of March, the succeeding summer is generally wet, five times in six.

In this country *winters and springs, if dry, are most commonly cold; if moist, warm*: on the contrary, dry summers and autumns are usually hot, and moist summers cold; so that, if we know the moistness or dryness of a season, we can form a tolerably accurate judgment of its temperature. In this country also, it generally rains less in March than in November, in the proportion at a medium of 7 to 12. It generally rains less in April than October, in the proportion of 1 to 2, nearly at a medium. It generally rains less in May than September; the chances that it does so, are, at least, 4 to 3; but, when it rains plentifully in May, as 1·8 inches or more, it generally rains but little in September; and when it rains one inch, or less, in May, it rains plentifully in September.

2368. *The probabilities of particular seasons being followed by others*, has been calculated by Kirwan, and although his rules chiefly relate to the climate of Ireland, yet as there exists but little difference between that island and Great Britain, in the general appearance of the seasons, we shall mention some of his conclusions.

In *forty-one years* there were six wet springs, 22 dry, and 13 variable; 20 wet summers, 16 dry and 5 variable; 11 wet autumns, 11 dry, and 19 variable.

A *season is accounted wet*, when it contains two wet months. In general, the quantity of rain, which falls in dry seasons, is less than five inches, in wet seasons more; variable seasons are those, in which there falls between 30 lbs. and 36 lbs., a pound being equal to 157639 of an inch.

*January is the coldest month* in every latitude; and July is the warmest month in all latitudes above 48 degrees: in lower latitudes, August is generally the warmest. The difference between the hottest and coldest months increases in proportion to the distance from the equator. Every habitable latitude enjoys a mean heat of 60 degrees for at least two months; which heat is necessary for the production of corn.

### SECT. III. *Of the Climate of Britain.*

2369. *The climate of the British isles*, relatively to others in the same latitude, is temperate, humid, and variable. The moderation of its temperature and its humidity are owing to our being surrounded by water, which being less affected by the sun than the earth, imbibes less heat in summer, and from its fluidity is less easily cooled in winter. As the sea on our coasts never freezes, its temperature must always be above 33° or 34°; and hence, when air from the polar regions at a much lower temperature passes over it, that air must be in some degree heated by the radiation of the water. On the other hand, in summer, the warm currents of air from the south necessarily give out part of their heat in passing over a surface so much lower in temperature. The variable nature of our climate is chiefly owing to the unequal breadths of watery surface which surround us; on one side, a channel of a few leagues in breadth; on the other, the Atlantic ocean.

2370. *The British climate varies materially within itself*: some districts are dry, as the east; others moist, as the west coast; in the northern extremity, dry, cold, and windy; in the south, warm and moist. Even in moist districts some spots are excessively dry, as part of Wigtownshire, from the influence of the Isle of Man, in warding off the watery clouds of the Atlantic; and, in dry districts, some spots are moist, from the influence of high mountains in attracting and condensing clouds charged with watery vapor.

2371. *The deterioration of the British climate* is an idea entertained by some; but whether in regard to general regularity, temperature, moisture, or wind, the alleged changes are unsupported by satisfactory proofs. It is not improbable but the humidity of our climate, as Williams alleges (*Climate of Britain*, &c. 1816), has of late years been increased by the increase of evaporating surface, produced by the multiplicity of hedges and plantations; a surface covered with leaves being found to evaporate considerably more than a naked surface. If the humidity of the climate was greater before the drainage of morasses and the eradication of forests for agricultural purposes, a comparative return to the same state by artificial planting and irrigation, must have a tendency to produce the same results. However, it will be long before the irrigation of lands is carried to such a degree as to produce the insalubrious effects of undrained morasses; and as to our woods and hedges, we must console ourselves with the beauty and the shelter which they produce, for the increase of vapor supposed to proceed from them.

---

## BOOK IV.

### OF THE MECHANICAL AGENTS EMPLOYED IN AGRICULTURE.

2372. HAVING taken a view of the vegetable and animal kingdoms, as supplying the subjects of agricultural improvement, and of the mineral kingdom, manures, and the weather, as the natural agents of their growth and culture; our next course is to examine the mechanical agents, or *implements, machines, and buildings employed in agricultural operations*. In a rude state of husbandry few implements are required besides the plough and the cart, and few buildings beside the stable and the barn. The ground is ploughed, and the seed thrown in and covered with a bush; at harvest it is cut down and carted to the barn; and the three grand operations of the farmer are sowing, reaping, and thrashing. But in our improved state of society, where all the science of mechanics as well as chemistry, is made to bear on agriculture, the implements, machines, and buildings become numerous, and equally so the operations. So numerous are the former, indeed, that the theoretical enquirer is often puzzled in making a selection. The whole of the most improved agriculture, however, may be, and in fact is, carried on with a very limited variety both of implements and buildings: intricate and complicated machines are not adapted for a rustic art like agriculture, and a great variety are not required for an art whose operations are so simple as almost to be universally understood and practised. In our enumeration we shall include a number that we do not consider of much consequence; but we shall always distinguish between the essential, and such as are comparatively objects of superfluous ingenuity and expense. We shall adopt the order of *Implements of Manual Labor, Implements or Machines impelled by quadrupeds or other powers, Structures, and Buildings*.

---

### CHAP. I.

#### *Of the Implements of Manual Labor used in Agriculture.*

2373. Though the most important implements of agriculture are drawn or put in action by beasts of labor, yet a few are used *by man alone*, which cannot be dispensed with. These may be arranged as tools, or simple implements for performing operations on the soil; instruments for performing operations on plants or animals, or other more delicate operations; utensils for the deportation of materials; and hand machines for various purposes.

#### SECT. I. *Tools used in Agriculture.*

2374. *The lever* is an inflexible straight bar of iron or wood, employed in connection with a prop or fulcrum, on which it is supported. There are three kinds, but the most common is that in which the fulcrum is between the power and the weight. Its use in the removal of large stones or other heavy bodies is well known, and the advantage of its application depends on the distance of the power from the fulcrum, and the proximity of the weight.

2375. *The pick or mattock* consists of two parts, the handle, which ought to be formed of sound ash timber or oak, such as is obtained from the root or butt end of a middle aged tree; and the head, which should be formed of the best iron and pointed.

with steel. The handle ought to be perfectly cylindrical, as in using it one hand slides along it from the end next the operator towards the head. There are several varieties; the first the pick, with the ends of the head pointed, used for loosening hard ground, gravel, &c.; the second, the pick axe, with the ends wedge-shaped in reversed positions, used in digging up trees; the third, the grubber, for grubbing up heath or small brushwood; and there are also the road pick, and some others.

2376. *The spade* consists of two parts, the handle of ash, generally about two feet nine inches long, and the blade of plate iron. There are several varieties; 1. with a curved outline to the extremity of the blade, by which it may be made to enter a stiff soil with less power; 2. with a perforated blade, which in adhesive soils frees itself better from earth in the using; 3. with a sub-semicylindrical blade, which enters a stiff soil easier than the common form, is much stronger as a lever, and also frees itself well from the spiteful of earth: this variety is what canal diggers chiefly use, and is called by them a grafting tool. There are other varieties and subvarieties used in draining, and for particular purposes; which will be noticed at the proper place.

2377. *The shovel* differs from the spade in being made with a broader and thinner blade; its use being to lift, rather than cut and separate. There are several varieties differing in the form and magnitude of the blade. One variety, the barn shovel, has the blade generally of wood, sometimes edged with iron.

2378. *The turf-spade* consists of a cordate or scutiform blade, joined to a handle by a kneed or bent iron shank. It is used for cutting turf from pastures, and in removing ant-hills and other inequalities. A thin section is first removed, then the protuberance of earth is taken out and the section replaced, which, cut thin, and especially on the edges, readily refits; and the operation is finished with gentle pressure by the foot, back of the spade, or roller. One variety (*fig. 250.*) has one edge turned up, and is preferable where the turfs are to be cut square-edged and somewhat thick.

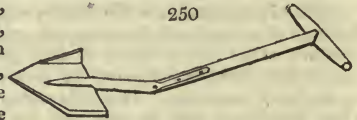

2379. *The fork* is of several kinds; the dung-fork for working in littery dung, consisting of a handle like that of the shovel, and three or more prongs instead of a blade; the hay or pitch-fork, for working with sheaves of corn or straw or hay, consisting of a long handle and two prongs; and the wooden fork consisting of a shoot of willow, ash, or other young tree or sapling, forked at the extremity, barked and formed into a rude fork, sometimes used in hay-making, and similar operations. The prongs of forks to take up loose littery dung, will work easiest when the prongs are round.

2380. *The rake* used in agriculture is of two kinds, the hay-rake and the corn-rake. Both consist of a handle and head set with teeth; in the corn rake these are generally of iron. The garden-rake is sometimes used for covering small seeds.

2381. *The hay-rake* is usually made of willow that it may be light and easy to work; and the teeth should be short, otherwise they are apt to pull up the stubble or roots of the grass in raking. Sometimes the teeth are made to screw into the head, and fasten with nuts, which prevents their dropping out in dry seasons.

2382. *The corn-rake* (*fig. 251.*) is of different dimensions and constructions in different counties. In general the length of the rake is about four feet; and the teeth of iron about four inches long, and set from one to two inches apart. Young (*Report of Norfolk*) mentions one of these dimensions which had two wheels of nine inches diameter, and so fixed that the teeth may be kept in any posture at the will of the holder. It was used both for hay and corn, and answered the purpose well.

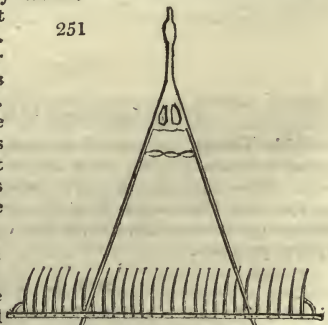

2383. In *East Lothian* a corn-rake has been tried, which according to Somerville (*Survey, &c.*) has been found to answer much better than the common corn rake. In this, the length of the head is from ten to fifteen feet, the handle about seven feet, with a piece of wood across the end of it, by which it is drawn by two men. The teeth are of wood or iron, the last are the best, as well as the most durable, and are a little bent forward at the point, which gives them the power of retaining and carrying the ears along with them much better than they would otherwise do. To make clean work, especially if the ridges are rounded, the field is raked across; in that way every thing is taken up; but when it is preferred to draw the rake in the direction of the ridges, it may be considerably improved by cutting the head into two or three lengths (*fig. 252.*), and join-

ing them with hinges, which will allow it to bend and accommodate itself to the curvature of the ridges. The advantage of this kind of rake has been found considerable, even in cases where every possible attention has been paid to the cutting of the crop.

2384. *The stubble, or dew rake*, is merely a coarser sort of corn rake.

2385. *The daisy rake*, has teeth sharpened on both edges like lancets, and is used for raking off the flower heads or buds of daisies, and other plants in grass lawns.

2386. *The drill rake* is a large headed rake, in which the teeth are triangular, in section like small coulters; they are set at six or twelve inches distance, according to circumstances, and the implement is used to draw drills across beds or ridges, for sowing field crops of small seeds or roots, such as onions, early turnips, carrots, &c. or for planting saffron or Indian corn.

2387. *The dung drag*, or dung hack, is a two or three pronged implement, with a long handle for drawing the dung out of carts in different portions. The form of the prongs should be flat.

2388. *The earth hack* resembles a large hoe, and is used for emptying loads of earth or lime, or other pulverulent matters, in the same manner as the dung drag is used for emptying dung; it is sometimes also used as a hoe, and for scraping and cleaning.

2389. *The hand hoe*, commonly used in agriculture, is of two kinds; that with an entire and that with a perforated blade. The last variety is preferable for thinning crops or destroying weeds, as it does not collect the soil and the weeds together in heaps; but where earthing up is the object, the common square blade is the best. The breadth of the blade may vary from two to twelve inches, according as the soil is adhesive or loose, or the plants to be thinned to a greater or lesser distance. An improvement for hoes to be used in stirring stiff soils, consists in forming the blade with a prong or prongs on the opposite side of the broad blade, which can be used in very stiff places to loosen them, by the operator's merely altering the position of the handle. The blades of all hoes enter the soil easier when curved than when straight, the wedge in the former case being narrower.

2390. Various *improvements in hoes* have been attempted by agriculturists. One with a triangular blade has been recommended as adapted to thin either at a greater or lesser distance, according to the depth it is thrust into the soil. Lord Somerville recommends the forked tool (fig. 253 a.) or heavy hoe, used in the vineyards on the continent; but it is an implement more oppressive to the cultivator than a spade, as it requires him to stoop very low. Duckett, jun. recommends a treble hoe (b) for thinning; another of a different description (c) for making drills by drawing; one for making them by striking in a line, in order to form a trench for dung and potatoes (f); one for forming a drill in the common way (e); and, lastly, one for hoeing both sides of a drill at once (d). It is said that by this last tool two acres of barley may be hoed in a day, and that it makes good work among oats or wheat. But such hoeing, even on the slightest soils, can be little more than a mere scraping of the surface; and though the weeds may be cut, yet this is only one object of hoeing.

2391. *The breast hoe*, or breast plough, which is pushed before the operator like the thrust hoe of gardening; and M'Dougal's hoe, which is drawn by a man before, and pushed by another behind, with other varieties, need not be described.

2392. *The scraper* may be described as a broad hoe, of treble the usual size and strength, used in cleaning roads or court-yards, and sometimes in cleaning grassy surfaces. One with the ends of the blade turned an inch or two, is found more effective in scraping the mud or dust from roads.

2393. *Of weeding tools* used in agriculture there are three or four kinds; one with a long handle and fulcrum to the blade, for digging docks and other tap rooted plants from pastures; a common spud or spadelet for cutting smaller weeds in hedges or standing corn; a thistle spud for cutting and rooting out thistles in pastures; besides short handled weeders of different kinds, to be used in hand-weeding young and delicate broad cast crops, as onions, &c. in stiff soils.

2394. *Weeding pincers, or thistle drawers*, (fig. 254.) are sometimes used for pulling thistles out of hedges and from among standing corn: the handles are about two feet six

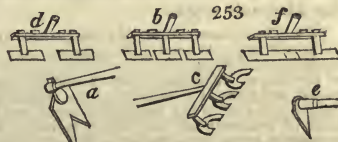
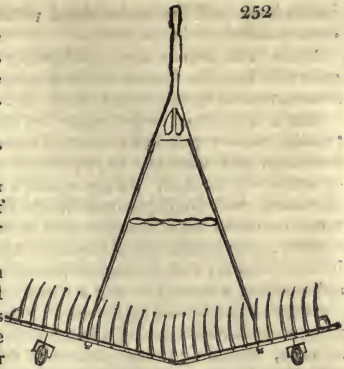

inches long, and the blades faced with plate iron made rough by cross channels or indentations.

2395. *The besoms* used in farming are commonly small fagots with handles, formed of birch spray for the stables and cattle-houses, and of broom, heath, straw, &c. for the barns.

2396. *The straw rope twister or twisting crook*, is used for twisting straw ropes, and consists of a stick or rod from two to three feet long, and from one to two inches diameter, either naturally or artificially crooked. At one end is a ring through which a cord is passed, and the implement tied to the waist; at the other is a notch on which the commencement of the rope is made.

2397. *The potatoe dibber* is exclusively used in planting potatoes in fine moulds; but drilling is a mode generally to be preferred, as providing a better bed and a closer covering to the sets.

2398. *The common dibber* used in agriculture, has several teeth or dibbles proceeding from a head, which having a handle, is pressed into the ground, and forms several holes at once, according to the number of dibbles, and these are regulated by the hardness of the soil. In strong clays the common garden dibber, shod with iron, is often used.

2399. *The flail* is a well known implement for beating out corn, now happily going out of use in the most improved districts, as it would every where, were the value of the hand threshing machine generally known.

2400. *The essential agricultural tools* are the pick, the spade, shovel, dung and hay-fork, hay-rake, common hand hoe, and besom.

## SECT. II. Instruments.

2401. *The instruments used in agriculture* may be classed as the common and the scientific; the former are used in executing, the latter chiefly in designing and laying out operations.

### SUBJECT. 1. Instruments of Labor.

2402. *The instruments of labor peculiar to agriculture* are few, and chiefly the scythe, reaping hook, and hay knife; but there are some others common to agriculture and gardening, which are occasionally used, and they also shall be enumerated.

2403. *The scythe* is of three kinds; one for cutting grass or herbage crops for hay, which consists of a thin steel blade attached at right angles to a handle of six or eight feet long; and the other for cutting corn, to which what is called a cradle is attached; the third is of smaller dimensions, and is exclusively used for cutting corn; it is called the Hainault scythe.

2404. *The Hainault scythe* (fig. 255.) has a wooden handle an inch and a quarter in diameter, and is held in the mower's right hand by the bent part (*a, b*) about five inches long. The straight part of the handle (*c*) is from 16 to 22 inches long, according to the height of the mower. There is a leathern loop (*b*) through which the fore finger is passed, and there is a knob (*a*) at the extremity, which would prevent the hand slipping off, if the loop should break, or the finger slip out of it. The blade (*d*) is about 2 feet long, and  $2\frac{1}{2}$  inches broad at the middle. The handle is attached to the blade in such a manner, as that its plane makes an angle with that of the latter, by which means the mower is able to cut a little upwards, but almost close to the ground without stooping, while the handle inclines to the horizon about 60 or 70 degrees. The line of the crooked part of the handle (*a, b*) if produced, would nearly pass through the point of the blade, which thus gives the means of controlling that point; whilst the fore finger in the loop commands the heel (*e*). Along with the scythe a light staff (*f, g*), terminating in an iron hook (*h*), is used by the mower. With the scythe in his right hand, he holds the hook in his left by the middle, the curved part of it over the scythe in a similar position to its blade, and above it, their points being exactly above each other. In working, the mower moves both together, making the hook to pass behind the straw at about the middle of its height, to separate and press it slightly down towards the left hand, while the blade follows with a motion from right to left to cut off the straw at from two to four inches above the ground. A great advantage of this implement is, that the operator is not required to stoop, by which his strength is less exhausted, and he is said to cut double the quantity of corn which can be cut in the same time with the reaping-hook, and with less loss of straw.

254



255

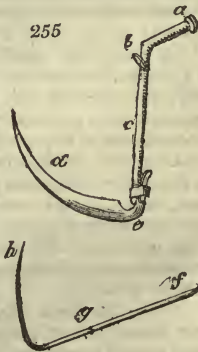

256



2405. *The cradle scythe* (fig. 256.) is variously constructed: sometimes the cradle or receptacle into which the corn is gathered is of net-work, and at other times it consists of woven laths or wicker work. (See 398.)

2406. *The reaping hook* is a curved blade of steel, fixed in a short wooden handle; it is of two kinds; one serrated like a fine saw, which is used in cutting corn by handfuls, and is called a sickle hook; the other smooth and sharp like a scythe, which is used to hack the corn over in the peculiar manner called bagging, and is called a cutting hook.

2407. *Hutton's improved reaping hook* is serrated from the point through half its length like a sickle, and the remainder is smooth and sharp. The advantage is, that the straws are not cut in entering the hook,



as is the case where the point is of the cutting kind, by which means fewer drop and are lost. With sickles reapers invariably make cleaner work than with the hooks for the above reason; with hooks the straws are cut with less labor. (*Trans. Soc. Arts.* vol. 28.)

2408. *The hay knife* consists of a straight blade set at right angles to a short wooden handle; both of considerable strength. It is used for cutting hay or straw when consolidated in the rick or stack. An improvement of this instrument has been proposed, which consists in forming the blade like that of a common spade, sharp at the edges, by which the operator will cut downwards instead of obliquely, and not being obliged to stoop, will effect the same work with far less trouble.

2409. *The wool shears* are formed wholly of iron or steel, and worked with one hand.

2410. *The hedge shears* are of different kinds; that called the *averuncator* is to be preferred for cutting off large shoots, as it makes a clean draw cut like a knife. Shears, however, are not used in dressing hedges by the best agriculturists.

2411. *The thatching knife* consists of a blade similar to that of a scythe, inserted in a wooden handle like that of a reaping hook. For thatching with reeds, heath, or any rough and rigid thatch, the blade has a handle affixed to each end to enable the operator to work it with both hands.

2412. *The stack-borer* consists of a species of auger, the cutting part of which is of very sharp steel, and the stem eight or ten feet long, with a moveable cross handle for working it. There is also a screw similar to a common bottle screw, which works on or round the stem of the augur, and is applied at intervals to draw out the cut hay. This instrument is used by extensive growers of meadow or natural hay to bore holes through hay ricks when they heat, or to try the quality of the article. The hole made by the augur is about one foot in diameter.

2413. *The hedge bill* is of various kinds; most of them have long handles, but what are called *bill-hooks*, are a sort of axe with a hooked point and a short handle.

2414. *The axe, saw, wedges and hammers*, of different kinds and sizes, are used in agriculture, in felling trees, cutting them up, preparing fuel, driving nails, &c., but these and other instruments common to various arts need not be described.

2415. *Blackie's improved hatchet and bill-hooks* for cutting underwood, faggoting, and gapstopping, are superior instruments for these purposes. The long handled *Berwickshire hedge-bill* for dressing hedges, and the long handled saw for cutting off large branches of trees, are preferred for cutting over old hedges and undergrowths by the collar.

2416. *The line and reel* is occasionally wanted for the manual operations of agriculture, and should be procured rather stronger and with a longer line than those used in gardens.

2417. *The potatoe setscoop* is of two kinds; one a hollow semiglobe, (fig. 257 a.), and the other (b) a section of that figure. They are only used when potatoe are very scarce, as in ordinary cases the larger the set the more strength and rapidity of growth in the young plant.

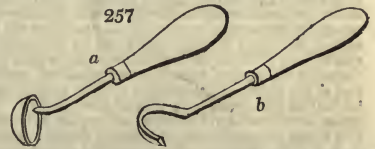

2418. *The Edinburgh potatoe scoop* (fig. 258.) is by far the best, and indeed the only one deserving of use. The handle (a) has a round stem which passes through a piece of metal (d) and has there a semicircular knife or cutter (e) fixed to it. This cutter is sharp on both edges and turns on a pivot fitted in a piece of brass formed out of a piece of plate (b, c). This plate forms a shield to hold this instrument firm upon the potatoe, by placing the thumb of the left hand upon it, and pressing the points in which the cutter is fixed, into the tuber. Then by turning the handle half round with the right hand, the semicircular knife cuts out a set which is a segment of a small sphere (e, f, g). The only attention necessary in the use of this instrument is, that it is placed upon the potatoe, with the eye or bud in the centre of the diameter of the semicircle of the knife when laid flat on the tuber. The advantages of this scoop, besides that it is very quick in its operation, is that the pieces being all exactly of one size, that is about an inch in diameter, may be planted by a bean barrow or drill machine, with much less labor and more accuracy than by the hand.



2419. *The essential instruments of labor* are the scythe, reaping hook, hay-knife, wool-shears, hedge-bill, axe, saw, hammer, and line and reel.

#### SUBSECT. 2. *Instruments of Science.*

2420. *Scientific instruments* are not much required in agriculture, the principal are for levelling, boring, and measuring.

2421. *The level* is frequently required in agriculture, for arranging surfaces for irrigation; tracing strata in order to cut off springs, well making, and a variety of other purposes. The simplest form is the common road or mason's level, and the most complete the spirit level, with a telescope and compass, such as is used by land surveyors; but when operations of only moderate extent are to be performed, very convenient and economical substitutes, and if used with care, equally accurate instruments, may be

found in the road or common levels (*fig. 259.*), water level, the triangular and the square level.

259

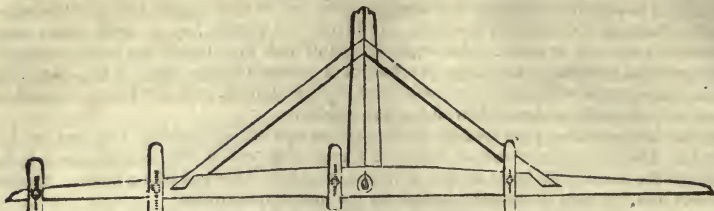

2422. The water level is that which shews the horizontal line by means of a surface of water or other fluid; founded on this principle, that water always places itself level or horizontal. The most simple level of this kind is made of a long wooden trough or canal, which being equally filled with water, its surface shews the line of level. It is also made with two cups, fitted to the two ends of a straight tube, about an inch in diameter, and three or four feet long, by means of which the water communicates from the one cup to the other, and this pipe being moveable on its stand by means of a ball and socket, when the two cups shew equally full of water, their two surfaces mark the line of level. It may also be made with two short cylinders of glass, three or four inches long, fastened at each extremity of the pipe with wax or mastic. The pipe is filled with common or colored water, which shews itself through the cylinders, by means of which the line of level is determined; the height of the water with respect to the centre of the earth, being always the same in both cylinders. This level is very simple and commodious for levelling small distances.

2423. The American or triangular level (*fig. 260 a.*) is formed of two pieces of thin wood joined by a cross bar, the whole in the form of the letter A. The manner of using it is simply thus: At the place from where the level is to be taken, drive a wooden peg into the ground, close in to the top, upon which one of the legs of the frame or A may rest; then bringing round the other leg till it touch the ground, there drive in a second peg, turning round the other leg as before; and where it touches the ground again, drive in another peg, and so on along the whole line to be levelled. Thus, with very little trouble, and with as much accuracy as with the finest spirit-level, may the course of a drain be easily ascertained. But as it is necessary that a drain should have as much declivity as to allow the water to run freely, it will be requisite, in taking the level, to regulate the direction of the line accordingly. Half an inch fall, in the length of the frame, will be sufficient. For this purpose, it will be expedient to have, besides a number of wooden pegs, one iron pin with inches and halves marked regularly upon the sides of it from the top downwards. After having drove in the first wooden peg at the point from whence you mean to conduct the drain, and having rested the one leg of the frame upon it, turn round the other till it be level with the first peg; there put in the iron pin, so that this leg of the frame may rest on the top of it, when level; then drive in a wooden peg so far, as that the top of it may be half an inch lower than that of the iron pin. Place the leg of the frame again upon this second peg, turn it round to a level, putting in the iron pin till the top of it be equal with the foot of the frame; then drive in another wooden peg close by the side of it, till the top of the wooden one be half an inch lower than that of the iron pin. Proceed in this manner so far as you mean to carry the drain, which will have the same degree of declivity all the way along. When made on a smaller scale, it is useful in ascertaining the proper descent along the bottom of a drain, while the workmen are laying it; but when made for this purpose, the cross-bar must be fixed to the bottom of the legs, so that the A becomes a  $\Delta$ , or delta.

2424. The square level (*fig. 260 b.*), is made of several pieces; the usual length generally five feet and a half, and the height four or four feet and a half. It may be either used like the water level, or the American level. According to Marshal, it has been found "preferable to any other level now in use, as being equally accurate in ascertaining the relative heights of distant objects, as in minutely tracing step by step the required line of communication, so as to give every part of it an equal and uniform descent."

2425. The object staff (*fig. 260 c.*) is used with the water or square level: for either it should be exactly of the same height as the level; the cross piece at top should be a foot or more in length, and three inches broad, painted white on one side for opposing to dark objects, and black on the other for opposing to such as are white.

2426. The levelling staff is composed of two pieces, (*fig. 260 d, h, and e, e*), which slide on each other: they are each of about five feet in length, so as to form, when fully extended, a rod of ten feet. They have a graduated line of feet into hundredth parts. The index (*f*) slides firmly on them; and is moved up or down (by signal) by the attendant who carries the staff, till the observer finds it coincide with the intersecting wires of his telescope. Its height on the staff, of course, marks the difference of the level. It has two horizontal and parallel black stripes, which at considerable distances are of use to direct the eye more readily to the fiducial edge (*g*).

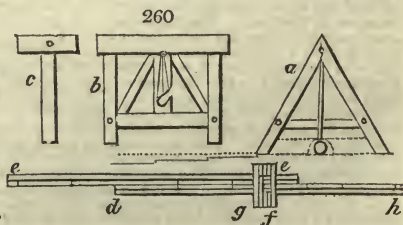

2427. *The measuring-chain, measuring-rod, pocket-rule, poles for setting out straight lines; stakes for driving in at fixed points, and a variety of other instruments, and their appendages are occasionally required by the agriculturist who lays out estates, or effects territorial improvements: but these not being strictly agricultural implements do not require to be described.*

2428. *The borer (fig. 261.) is an instrument invented for the purpose of searching or exploring the nature of soils. It is composed of two rods of iron (a, f, and b, g), each six feet long, and an inch in diameter. The end of one screws into the end of the other, after taking out the stopper (c), the use of which is to hinder either dirt or dust from getting into the screw. The screw is an inch and a half long, and three quarters of an inch in diameter: there is a steel point somewhat blunt (f), to pierce the earth or any substance it may meet with. It should be about three inches long, and made with either three, four, or more sides, as may be thought most convenient. It is screwed into the rod (a) in the same manner, and with a screw of the same size as is used in screwing the rods together. It has a groove six inches long, a third of an inch wide, and three quarters of an inch deep, rounded in the bottom, and intended to bring up part of each different layer through which it passes. When springs are sought for, a bit of sponge is put into the groove. At the end of the rod (g), is a screw to fix into another rod of the same kind, if it be found necessary to lengthen the instrument; and this may be repeated, by the addition of more rods, to any depth desired. The handle of this instrument (h, i), is two feet and a half long: this handle is fastened to the rod by means of a clasp (k, l) lined with steel, fixed at one end by a hinge, and at the other by a screw (l), so that it may be placed at any height. A lever handle (m) serves to stop the borer when bringing it up from a considerable depth, and also to screw and unscrew the several bars or joints as occasion requires, and to put on or take off the steel point at the bottom. The other handle (i, h) is that by which the rod is held, and worked into the earth, either by turning it round, especially at first, or, after it has penetrated to some depth, by lifting it up, and letting it fall again, which it does with such force as to pierce even the hardest rocks; especially if it work at any considerable depth, and has of course been lengthened accordingly; for every foot of this rod weighs three pounds. Two men will easily sound the depth of twelve feet in less than a quarter of an hour, if they do not meet with many stones. When the rod becomes too heavy to be properly managed by hand, it may be raised by a rope fastened at one end to the handle, and at the other to a roller, or kind of windlass, erected at a proper height, perpendicularly over the hole, and turned with either one or two handles: when let go, it will fall with such weight as to strike each time very deep into the earth.*

2429. *For making this instrument, the toughest iron is the best: it should be well hammered, till its surface is quite smooth and even; for the least roughness and inequality would occasion a friction, which would greatly retard its working. For the same reason, and also to increase the force of its fall, it is necessary that it should be perfectly straight; nor should it ever be struck with a mallet, hammer, &c. to force it down, because a blow might bend it, and it would easily break afterwards. The female screw must be turned like that in the breech of a gun-barrel, in a separate piece of iron, cross-ways to the grain; and this piece must be afterwards well soldered on to one of the ends of the rod. The reason for this is, that if the female screw were bored only at the end of the rod, it would, by being hammered out in the same direction with the grain, be stringy and porous, and consequently so weak as to give way, or burst, in the working of the rod; whereas, when made of a separate piece, taken cross-ways of the grain, the threads of the screw will run with the grain of the iron, and be thence considerably strengthened. A bit, like that of an auger, proportioned to the thickness of the rod, may at any time, when necessary, be substituted instead of the steel point, to draw up a sample of the substance from the very bottom of the sounding. If the only thing wanted be to know the nature of the under soil and layers of earth, so far as they may effect the vegetation of plants, it will be quite sufficient to bore eight or ten feet deep. A greater depth is only requisite when water, marl, ore, &c. is sought for.*

2430. *The peat-borer (fig. 262.), is a larger sort of borer, employed in peaty soils that are boggy, for the purpose of removing wetness. It has been used with advantage in some peat-mosses in Lancashire, by Eccleston.*

2431. *The draining auger, blasting auger, timber measurer, and other scientific instruments, not in general use in agriculture, will be best described in treating of the departments in which they are applied.*

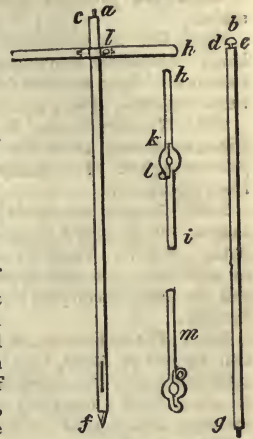

2432. *The only essential scientific instrument*, is the common level, which may be wanted to level drains, and water furrows, adjust the surface of roads, &c.

### SECT. III. *Utensils used in Agriculture.*

2433. *The principal agricultural utensils* are sieves, baskets, corn-measures, and sacks.

2434. *Sieves* are textures of basket work, wire, gut, or hair stretched on a broad wooden hoop. Sometimes also they are formed of skins or plate iron pierced with holes, and so stretched. They are used for separating corn, or other seeds from dust or other extraneous matters. There are different varieties for wheat, beans, oats, rape seed, &c.

2435. *The corn-screen* (fig. 263.), is a frame filled in with wires, so set as to allow dust and seeds smaller than corn to pass through it. It is chiefly used in granaries to free corn from the weevil.

2436. *Baskets* are made of wicker work of different shapes, but generally forming some section of a globose figure: they vary much in size; those in most general use in agriculture, are from twenty inches to two feet diameter, and are used for carrying roots, chaff, cut straw, &c. from one place to another in the farmery.

2437. *The seed carrier, or seed basket*, (fig. 264.) is sometimes made of thin veneers of wood, bent into an irregular oval with a hollow to fit the seedsman's side, and a strap to pass over his head, and rest on his shoulder. In some places, a linen bag of a shape adapted to be borne by the right shoulder, and suspend the seed under the left arm, is used for the same purpose.

2438. *The feeding tub or trough*, may be of any shape and size; it is used for giving short or liquid food to swine, sheep, and other live stock.

2439. *The pail* is used for carrying water, or other liquid food.

2440. *The turnip tray*, is a shallow moveable trough, or box, used to prevent waste when sheep are fed upon turnips.

2441. *The corn bin, or corn chest*, for containing oats or other grain for horses, may be an oblong box of any convenient size. Sometimes it is placed in the loft over the stable, and the corn is drawn out by a hopper below; but for a farm stable this is needless trouble: there it is commonly placed in the broad passage behind the horses, or in any spare corner. It should be stout, and have good hinges, and a safe lock and key.

2442. *The flexible tube* for relieving cattle that are hoven or choaked, consists of a strong leathern tube about four feet long and about half an inch in diameter, with a leaden nozzle pierced with holes at the insertion end. It should be kept in every farmery. There is a similar one, on a smaller scale, for sheep, which should be kept by all shepherds.

2443. *Corn measures* consist of the lippie, peck, and bushel, with the strike or rolling pin to pass over the surface, and determine their fulness. The local measures of every country are numerous; the Winchester bushel is the standard corn measure of England and Ireland; and the Linlithgow boll of Scotland. (See *Index*, article *Weights and Measures*.)

2444. *Corn sacks, or bags*, are strong hempen bags, calculated to hold four bushels; and in Scotland four firlots.

2445. *Other utensils*, as those of the dairy, poultry, and cyder-house, will be described in their appropriate places.

2446. *The essential agricultural utensils* are the sieve, basket, seed carrier, tub, pail, corn chest, flexible tube, corn measure, and corn sack.

### SECT. IV. *Hand Machines used in Agriculture.*

2447. *Agricultural hand machines* are generally portable; some are exclusively put in action by man, as the wheel-barrow; and others, as the straw-cutter, sometimes by horses, water, or other powers.

2448. *The common ladder* is the simplest of manual machines, and is in constant use for forming and thatching ricks, and other purposes; with or without the use of tressels and scaffolding.

2449. *The wheel-barrow* is of three kinds; the new ground work barrow (fig. 265.) used in moving earth or stones; the dung barrow (fig. 266.) for the farm yard; and the corn barrow (fig. 267.) for conveying corn from the stack-yard to the barn.

The body of the latter (b), may be made to separate from the frame and wheel, and by means of levers (a) to be carried like the hand-barrow.

263

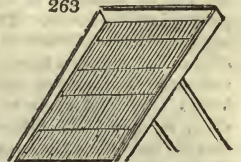

264



265



2450. *The sack-barrow* is a two handed lever of the first kind, the fulcrum of which is a pair of low wheels: it is a convenient machine for moving sacks in a granary or barn floor, from one point to another.



266

2451. *The hand-barrow* is in frequent use in various de-

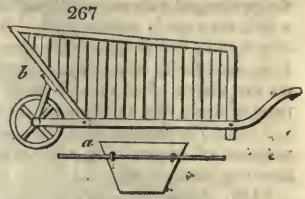

267

partments of agriculture, where the soil is soft, or the surface uneven. Its bottom should be close and strong for carrying stones; but may be light and open for dung or corn.

2452. *The winnowing-machine* (fig. 268.) is in use for cleaning corn, in most of the improved districts. There are different forms, but the best is that of Meikle, or the Berwickshire winnower, which, instead of one screen, has a set of sieves put in motion by the machine, by which means the corn comes out, in most cases, ready to be meted up in sacks. Some improvements have lately been made by Weir of London.

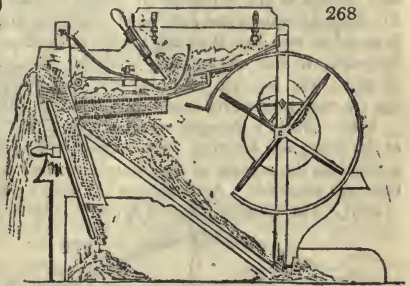

268

2453. *The hand threshing machine* (fig. 269.), is worked by two men, and one woman, and is greatly preferable to the flail for threshing the corn of a small

269

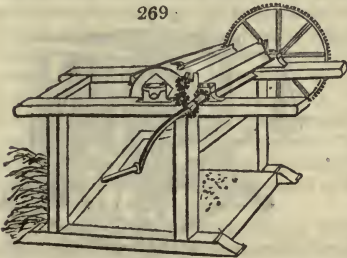

farm, or for threshing clover, or other small seeds. The advantage consists chiefly in the completeness in which the grain is separated from the straw.

2454. *The potato cleaner* is a hollow cylinder, or perforated cylinder, or barrel, with a wooden axle through its long diameter, and a handle at one end, by which it is turned like a barrel churn. A hinged board forms an opening for putting in and taking out the potatoes, which fastens with an iron hasp and staple. It is filled one-third with potatoes or other roots, and then placed in a cistern of water, by means of a crane or otherwise. In this state,

being two-thirds immersed in the water, and one-third full of potatoes, it is turned round a few times, when the latter are found cleaned, and the barrel lifted out by the crane, emptied, filled, and replaced.

2455. *The turnip-slicer* is of different forms; the old sort works by hand, like a straw-cutter of the original construction; but a better sort consists of a hopper and knives, fixed upon a fly wheel (fig. 270.). The turnips press against the knife by their own weight, and a man turning the wheel, will cut a bushel in a minute. Gardener's turnip slicer is a highly improved form of this machine.

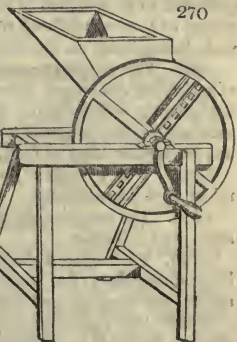

270

2456. *The turnip-chopper* is perhaps a more useful implement, than the turnip slicer. It is first made like the common nine-inch garden-hoe, forming an oblong square, with an eye to receive the handle: from the centre of the first hoe, another hoe crosses it at right angles, but this second hoe is not made solid as in the first common hoe, but is made like a Dutch hoe, the centre part of it being open the whole length of it. The turnip being pulled out of the ground by the angles of the hoe, is immediately struck with it about the centre, which divides it into four, and if these four pieces are not small enough, the stroke is repeated upon each of the pieces until they are sufficiently so. It is supposed capable of being greatly improved by having two stoutish prongs on the back or reverse part of the hoe, proceeding from the neck of the eye; these prongs would pull up the turnips with infinitely more expedition, and the increased weight of the hoe would rather be in its favor by lessening the force necessary to split the roots.

2457. *The rope-twisting-machine* (fig. 271.), is a small wheel, the prolonged axle or spindle of which terminates in a hook, on which the rope is commenced. It is commonly fixed to a portable stand; but is sometimes attached to a threshing-machine. It is used for twisting ropes of straw, hay, or rushes for tying on the thatch of ricks and other similar purposes. It is also used to form very thick ropes for forming straw drains.

271

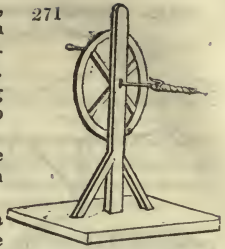

2458. *The draught-machine* is a contrivance invented for the purpose of ascertaining the force or power of draught, in drawing ploughs, &c.

2459. *More's draught-machine* is a spring coiled within a cylindrical case, having a dial-plate marked with numbers like that of a clock, and so contrived that a hand moves with the motion of the spring, and points to the numbers in proportion as the force is exerted: for instance, when the draught equals one cwt. over a pulley, the hand points to fig. 1; when the draught is equal to two cwt. it points to fig. 2, and so on. Till this very useful machine was invented, it was exceedingly difficult to compare the draught of different ploughs, as there was no rule to judge by, but the exertions of the horses as apparent to the eye; a very undecisive mode of ascertaining their force.

2460. *Braby's draught-machine* (fig. 272.), consists of two strong steel plates, joined at the ends, and forming a spheroidal opening between them. In using it, one end (a) is hooked on the muzzle of the plough or other implement, and to the other (b) the draught trees are attached. An indicator (c) points out the power applied in cwts.

2461. *The weighing-cage* (fig. 273.), is a contrivance made in the form of a sort

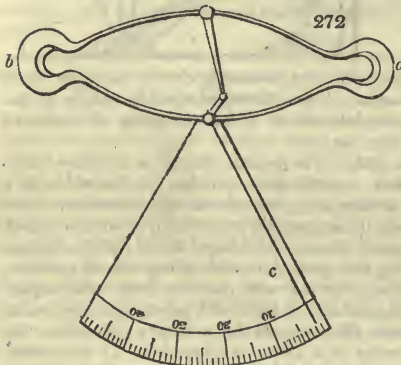

272

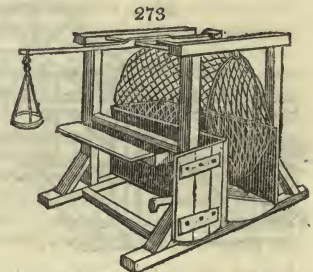

273

of open box or cage, by which any small animal, as a pig, sheep, calf, &c. may be very easily and expeditiously weighed, and with sufficient accuracy for the farmer's purpose. It is constructed on the principle of the common steel-yard, with a strong wooden frame and steel centres, in which the pivots of the lever are hung. And upon the short side of the lever is suspended a coop, surrounded by strong net-work, in which the animal intended to be weighed is placed; the point of suspension is connected with the coop by means of two curved iron rods, which at the same time form the head of it. A common scale being hung on the longer side of the lever.

2462. *The weighing-machine* is a contrivance of the steel-yard kind, for the purpose of weighing cattle and other animals alive. A machine of this sort is of importance in the grazing and fattening systems where they are carried to any considerable extent, in ascertaining the progress made by the animals, and shewing how they pay for the use of any particular kind of food, or what power it has in promoting the fattening process.

2463. *Weir's machine for weighing live bullocks*, is by far the simplest and most economical of these machines.

2464. *The weighing-machine for sacks* is a convenient piece of barn-furniture on the steel-yard principle.

2465. *The common steel-yard* will often be found useful for weighing corn or roots in large quantities; for smaller quantities, there are a variety of ingenious contrivances, among the simplest and easiest managed of which are those of Medhurst and Marriot.

2466. *The chaff-cutter* is used for cutting hay or straw into fragments not larger than chaff to facilitate its consumption by cattle. There are numerous forms; one of the most common is that of M'Dougal (fig. 274.), which is so formed, that in case of its being accidentally broken, it may be repaired by any common mechanic. The pressure of the straw is also capable of being regulated with great facility. But the great im-

274

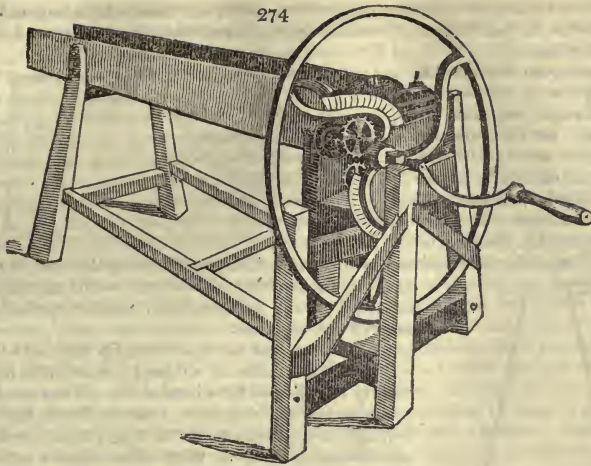

provement is in having applied a spiral groove, instead of the endless screw, by which friction is much diminished, and the lever may rise to any height, without putting the machine out of work.

2467. *The bruising-machine (fig. 275.),* is contrived for the purpose of bruising different sorts of grain, pulse, &c. as well as grinding malt. It is a simple implement, constructed with two iron rollers, of different diameters, turned true on their axles or spindles, each roller having a cog or tooth-wheel. A roller with grooves is fixed under the hopper, to receive the grain from the hopper, and lay it on the two rollers. To one of the rollers is fixed a fly-wheel. The machine is made to be worked by hand, or any other power. The upper wood frame is made to slide, and is regulated by a screw, according to the size of the grain, and will bruise it more or less, as may be required.

2468. *Of hand-drilling-machines,* there are a great many different kinds of various degrees of merit. The sort to be recommended in any particular case will depend on the texture of the soil; one which would answer well in a soft soil or sand might not succeed in a stoney or loamy soil. As the fashions of drills are continually changing, we advise intending purchasers to describe their soil and kind of culture, as whether raised or flat-drilling, &c. to a respectable implement-maker; in the mean time we submit a few of the established forms.

2469. *The bean or potatoe dibbling-machine (fig. 276.),* consists of a single wheel, set with dibber points, and which may be placed wider or closer at pleasure. It is pushed along by one man, and succeeds on friable soils, but cannot be depended on when the surface is rough or tenacious. Potatoe sets to be planted after this machine should be cut with the improved scoop (2418.).

2470. *The common drill-barrow (fig. 277.),* consists of a frame and wheel, somewhat similar to that of a common barrow, with a hopper attached to contain the seed. It is used for the purpose of sowing horse-beans, turnips, and such like seeds, upon small ridges. In using it, the laborer for the most part wheels it before him, the seed being afterwards covered by means of a

275

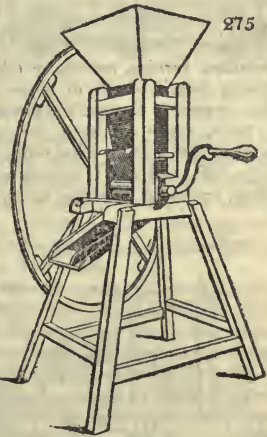

276

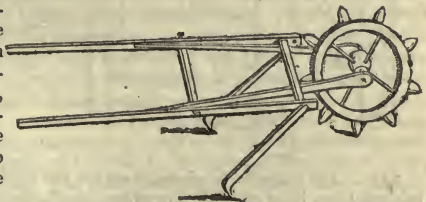

277



slight harrow, or sometimes by a shallow furrow.

2471. *The bean-drill* is a clumsy implement, better substituted by a box and wheel, to attach between the handles of any common plough, and thus deposit the seed after the furrow. (See *Bean*.)

2472. *The turnip barrow-drill* sows a single row at a time; but is of difficult management on the tops of ridges; for this purpose, it is desirable to have two wheels, one to go on each side of the ridge. A greatly improved variety of this machine, in use in Scotland (*fig. 278.*), has a barrel of water (*a*) attached, which, by

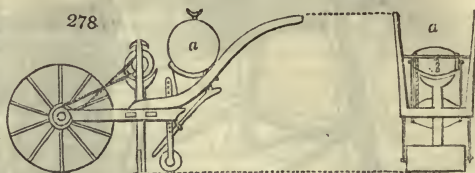

279

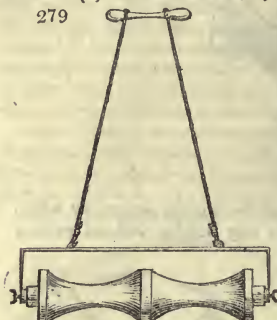

means of a tube, is dropped among the seed in the tract made by the coulter. This very useful appendage may be added to any drill-machine, whether worked by manual or animal labor.

2473. *The hand turnip-roller* (*fig. 279.*), is used for rolling raised drills or ridges previously to and after sowing turnip-seed by a hand-drill. The use of such a roller leaves the ridges in a much better form for receiving the seed than a common cylindrical roller, and after the seed is sown, when this roller is again used, the surface is left in the fittest state for retaining moisture, and for commencing the hoeing and thinning operations.

2474. *The root-breaker or bruiser* (*fig. 280.*), is composed of two widely fluted rollers, placed under a hopper, turned by two men. It is used for breaking or bruising potatoes, turnips, carrots, or other raw roots, into small or moderate sized pieces, before giving them to cattle or horses. The same implement may be set so close by means of two screws, as to serve for a whin-bruiser, or for breaking beans, or corn of any kind.

2475. *Other machines, for particular departments,* will be noticed in their proper places; and some will be wanted which are not peculiar to agriculture, such as rat-traps (*figs. 281. and 282.*), mouse and mole-traps (*fig. 283.*) a fowling-piece for shooting birds, scares for deterring birds, and similar contrivances.

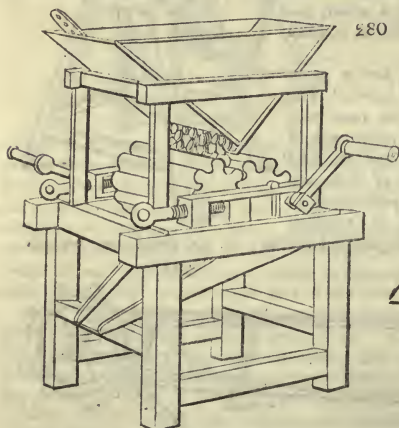

280

281

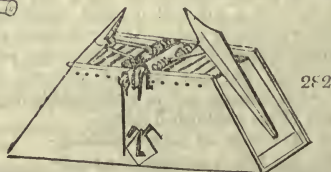
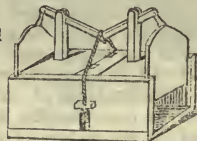

282

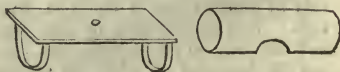

283

2476. *The essential hand-machines* are the ladder, wheel, and hand-barrows, winnowing-machine, hand-threshing machine, chaff-cutter, and turnip barrow-drill.

## CHAP. II.

*Of Agricultural Implements and Machines drawn by Beasts of Labor.*

2477. *The fundamental implements of agriculture* are the plough, the harrow, and the cart: these are common to every country in the slightest degree civilized; sufficiently



rude in construction in most countries, and only very lately brought to a high degree of perfection in Britain. Dr. Anderson (*Recreations in Agriculture, &c.*), writing in 1802, observes, "that there are no sorts of implements that admit of greater improvement than those of husbandry, on the principle of diminishing weight without in any degree abating their strength." Since that very recent period, great improvements have taken place in almost every agricultural implement, from the plough to the threshing machine, and though these have not yet found their way into general use, especially in England, they may be procured at the public manufactories of the capitals of the three kingdoms with no trouble. It is incredible what benefits would result to agriculture if proper ploughs and threshing machines were generally adopted; and if the scuffler or cultivator were applied in suitable soils, and under proper circumstances, not to mention one and two horse carts, improved harrows, and the best winnowing machines. But the ignorance and antipathy to innovation of the majority of farmers in almost every country, the backwardness of laborers to learn new practices, and the expense of the implements, are drawbacks which necessarily require time to overcome. It may also be observed, that in the progress of improvement, many innovations which have been made, have turned out of no account, or even worse than useless; and this being observed by the sagacious countryman, confirms him in his rooted aversion to novelty and change. — In our selection, we shall pass over a great variety of forms, the knowledge of which we consider of no use, unless it were to guard against them, and shall chiefly confine ourselves to such as are in use at the present time by the best farmers of the best cultivated districts. These we shall arrange as tillage implements, sowing and planting implements, reaping machines, threshing machines, and machines of deportation.

#### SECT. I. *Of Tillage Implements and Machines.*

2478. *The tillage implements of agriculture comprise ploughs with and without wheels, and pronged implements of various descriptions, as grubbers, cultivators, harrows, rollers, &c.* We shall take them in the order of swing ploughs, wheel ploughs, pronged implements, harrows, and rollers, &c.

##### SUBSECT. 1. *Of Swing Ploughs, or such as are constructed without Wheels.*

2479. *The plough is the first implement in agriculture, and hence the importance of selecting the most improved form.* As ploughing, however, like many other operations in practical husbandry, must often vary in the manner of its being performed, it is evident, that no one particular sort of plough can be superior to all others, in every season, and under every variety of soil or inclination of surface. Different soils, situations, and uses, will of course require different kinds of ploughs, though there are undoubtedly some that are capable of a much more general application than others.

2480. *Ploughs are of two kinds; those fitted up with wheels, and called wheel ploughs, and those without wheels, called swing ploughs.* The latter are the lightest of draught, but require an experienced and attentive ploughman to use them; the former work with greater steadiness, and require much less skill in the manager: some sorts, indeed, do not require holding at all, excepting at entering in, and turning on and off the work at the ends of the ridges. On the whole, taking ploughmen as they are, and ploughs as they are generally constructed, it will be found that a district ploughed with wheel ploughs, will show greater neatness of work than one ploughed with swing ploughs. But on the other hand, taking a district where the improved form of swing ploughs is generally adopted, the ploughmen will be found superior workmen, and the work performed in a better manner, and with less expense of labor than in the case of wheel ploughs. Northumberland in this respect may be compared with Warwickshire. In attempting to introduce the improved swing plough into any district, it will be found a very useful mode to have wheels applied to it in a temporary manner, so as they may be removed altogether when the operator becomes expert, or in the most favorable soils.

2481. *In the construction of ploughs, whatever be the sort used, there are a few general principles that ought invariably to be attended to; such as the giving the throat and breast, or that part which enters, perforates, and breaks up the ground, that sort of long, narrow, clean, tapering, sharpened form that affords the least resistance in passing through the land; and to the mould-board, that kind of hollowed-out and twisted form, which not only tends to lessen friction, but also to contribute greatly to the perfect turning over of the furrow-slice.* The beam and muzzle should likewise be so contrived, as that the moving power, or team, may be attached in the most advantageous line of draught. This is particularly necessary where a number of animals are employed together, in order that the draught of the whole may coincide.

2482. *The construction of an improved swing plough is thus given mathematically by Bailey of Chillingham, in his Essay on the Construction of the Plough on Mathematical*

*Principles*, 1795. It had been previously aimed at by Small of Berwickshire, and subsequently by Vetch of Inchbonney, near Jedburgh. (*Highland Soc. Trans.* vol. iv. p. 243.)

2483. *Land, when properly ploughed*, Bailey observes, must be removed from a horizontal position, and twisted over to a certain angle, so that it may be left in that inclining state, one furrow leaning upon another, till the whole field be completely ploughed. The depth and width of the furrows which is most approved of by farmers, and commonly to be met with in the best ploughed fields, are in the proportion of two to three; or, if the furrow be two deep, it must be three wide, and left at an angle of 45 to 46 degrees.

2484. *Various forms* have been given to the different parts of the plough, by ingenious persons, according to their different fancies, in order to diminish the weight of the draught, and to turn over the furrow, and leave it in its proper position, without tearing or breaking it.

2485. To have the *line of draught* at right angles to the horse's shoulders, is of great importance in the formation of a plough, a circumstance of which the greatest part of the plough-makers are totally ignorant, although it is well known to every one that has the least knowledge of mechanics. If we take the angle that the horse's shoulders make with a perpendicular from the horizon, and continue another line at right angles to it, or parallel to the draught chain; the length of this line from the horse's shoulders to where it meets or crosses the coulter, at half the depth of the furrow, will be thirteen feet two inches for ordinary sized horses.

2486. *Length of beam*. If the plough be properly made, the line of draught should pass through the middle hole of the plough bridle at the point of the beam. This requires the beam to be seven feet long, to give it a proper height at the bridle.

2487. *Left side plane*. That part of the plough next the solid land, should be made a perfect plane, and run parallel to the line of draught; whereas some of the common ploughs are completely twisted in that part, and deviate more than two inches from the line of draught; this throws the plough to the left, and causes the hinder part of the mould-board to press hard against the furrow, and crush and break it, besides increasing the labor of the cattle.

2488. *The position of the coulter* must not deviate much from an angle of 45 degrees; for, if we make it more oblique, it causes the plough to choke up with stubble and grass roots, by throwing them up against the beam; and, if less oblique, it is apt to drive the stones or other obstacles before it, and make it heavier to draw.

2489. Of *swing ploughs*, the best, is the implement known in England as the *Scotch plough*. It is almost the only plough used in Scotland, and throughout a considerable part of England; it is drawn with less power than wheel ploughs, the friction not being so great; and it probably admits of greater variations in regard to the breadth and depth of the furrow-slice. It is usually drawn by two horses abreast in common tillage; but for ploughing between the rows of the drill culture, a smaller one drawn by one horse, is commonly employed. A plough of this kind, having a mould-board on each side, is also used both in forming narrow ridges for turnips and potatoes, and in laying up the earth to the roots of the plants, after the intervals have been cleaned and pulverised by the horse and hand-hoe. This plough is sometimes made in such a manner, that the mould-board may be shifted from one side to the other when working on hilly grounds; by which means the furrows are all laid in the same direction;—a mode of construction as old as the days of Fitzherbert, who wrote before the middle of the sixteenth century. This is called a *turn-wrest plough*.

2490. *Swing-ploughs, similar to the Scotch plough*, have been long known in England. In Blythe's *Improver Improved* (edit. 1652), we have engravings of several ploughs; and what he calls the "plain plough," does not seem to differ much in its principal parts from the one now in use. Amos, in an *Essay on Agricultural Machines*, says, that a person named Lummis (whom he is mistaken in calling a Scotchman, see Maxwell's *Practical Husbandman*, p. 191.) "first attempted its construction upon mathematical principles, which he learned in Holland; but having obtained a patent for the making and vending of this plough, he withheld the knowledge of these principles from the public. However, one Pashley, plough-wright to Sir Charles Turner of Kirk-leatham, having a knowledge of those principles, constructed upon them a vast number of ploughs. Afterwards his son established a manufactory for the making of them at Rotherham. Hence they obtained the name of the Rotherham plough; but in Scotland they were called the Dutch or patent plough." "At length the Americans, having obtained a knowledge of those principles, either from Britain or Holland, claimed the priority of the invention; in consequence of which, President Jefferson, of the United States, presented the principles for the construction of a mould-board, first to the Institute of France, and next to the Board of Agriculture in England, as a wonderful discovery in mathematics." (*Communications to the Board of Agriculture*, vol. vi. p. 437.) According to another writer, the Rotherham plough was first constructed in Yorkshire, in 1720, about ten years before Lummis's improvements. (*Survey of the West Riding of Yorkshire*. *Sup. Encyc. Brit. art. Agr.*)

2491. *The present improved swing plough* (fig. 111., p. 127.), was little known in Scotland till about the year 1764, when Small's method of constructing it began to excite attention. (*Small's Treatise on Ploughs and Wheel Carriages*, 1784; and *Lord Kaimes's Gentleman Farmer*.) This ingenious mechanic formed the mould-board upon distinct and intelligible principles, and afterwards made it of cast-iron. His appendage of a chain has been since laid aside. It has been disputed, whether he took the Rotherham, or the old Scotch plough for the basis of his improvements. The swing plough has been since varied a little, in some parts of Scotland, from Small's form, for the purpose of adapting

it more completely to particular situations and circumstances. Of late this plough has been made entirely of iron. In Northumberland the mould-board is made less concave than in Berwickshire, and in Berwickshire it is even less concave than Small's plough. Different degrees of concavity in the mould-board suit different soils: soft and sandy soil requires most, and a loamy or clayey soil least concavity.

2492. *The Somerville plough* is known by its mould-board, a part of which is rendered moveable by hinges; the advantage of this is, that the furrow can be laid more or less flat at pleasure. "Mould-boards," Lord Somerville observes, "formed to lay furrows in ley, so as to give the most soil to harrows, cannot be of that form best calculated to make good work in stirring earths, more especially the last, which ought to be thrown up in small seams, as it were, that the seed may be duly buried. It has hitherto been held necessary to rip off the plate for this purpose, and drive in wedges, by which the mould plate must be injured. From the trouble attending this operation, it has generally been omitted, and the land, of course, imperfectly worked. But this inconvenience may be remedied, and the mould-board be adjusted with great facility and expedition, by the following means: When the mould-board is formed, and its plate fitted as usual, let the hind part be cut off, and again connected with the fixed part of the mould-board by means of flat hinges, or of thin flexible plates of tempered steel, or of hard hammered iron, so as to admit of that part being set to have different inclinations with the fixed part of the mould-board: by means of a screw passing from the inside through the lower parts of the handle of the plough, opposite the back of this moveable piece, the screw may be made to keep it at any desired degree of inclination, according to the nature of the work to be performed. — This plough, however, has been but little used, and does not seem to meet the approbation of the best cultivators.

2493. *The turn-wrest swing plough* (fig. 284.), is very useful for working on the side of steep hills, or in a diagonal direction, where the furrow-slice may be turned to the lower side. The labor, both to men and cattle, is greatly increased, when ploughing steep grounds, straight up hill. In some cases, where the declivity is

great, a furrow can only be taken down hill, which is a very tedious operation; whereas a plough of this form, in which the mould-boards are easily shifted to any side, may be employed with less labor to the cattle, and with greater expedition; because the ploughman, having it in his power to turn the earth of the furrow-slice either to the right or left hand, according as it answers his purpose, can always turn it to the lower side, where he is ploughing in a diagonal direction, or straight along the side of a steep hill. The form of this plough is somewhat different from that of the common plough, and may be made in different ways. But the beam, head, and sleath must always be placed in the direction of a line passing along their middle; and the two handles must be placed equidistant on each side of that line. There are two mould-boards and two coulters, and a mould-board is produced on either side, at pleasure, by moving the lever (a) between the plough handles from the one side to the other. The line of draught can be shifted with equal ease and expedition, and at the same time one of the coulters raised up clear of the land, and placed along the side of the beam, whilst the other is put down, and placed in a proper position for cutting off the furrow-slice from the furrow ground. All this is performed at once, without the ploughman's changing his position, by means of two levers (b, c, and d, a). In short, this is one of the best of implements of its kind, and where the use of a turn-wrest plough is recommendable, no other variety will be found to equal it. We have already noticed (2489.) the mode in which the double moulding or earthing-up swing plough, may be rendered a turn-wrest plough, of a less perfect kind.

2494. *Ducket's skim coulter plough* (fig. 285.), is considered a valuable implement, though not much in use. By it the

ground may be opened to any depth in separate horizontal portions of earth; and as the weeds or grassy surface are turned down in the first operation, and covered by fresh earth or mould from beneath, a larger proportion of nourishment is supposed to be provided for the crop, while at the same time it is rendered more clean, and the inconvenience of the roots of the grasses or other plants wholly got rid of. It requires a strong team in the heavier sorts of soil, but this

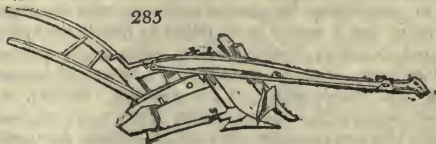
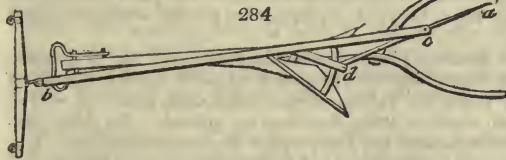

is in some degree counterbalanced by the circumstance of one such ploughing being mostly sufficient for the crop. It is, says a late theorist, consequently evident that, considering the number of ploughings generally given in the ordinary way of preparing lands for a crop of barley or turnips, and under the fallowing system for wheat, and the labor and expense in the latter case, in raking, picking, and burning weeds, the advantages of this plough are probably greater than is generally supposed. It has also advantages in another point of view, which is, that the soil is increased in depth, and the parts of it so loosened and broken down that the fibrous roots of the crops strike and extend themselves more readily in it, and of course are better fed and supported. In thin and sandy soils it is more particularly useful, because it cuts off all which is on the surface, at the depth of an inch or an inch and a half, in order to its being laid in a state of decay, for a future crop, by which an increased depth of soil is given to every subsequent course of crops, and which often acts as a support, to keep up manures near the surface, as their running through such soils too quickly is a disadvantage. It is also capable of being made use of without a skim-coulter as a common plough.

2495. *A skim coulter* may be added to any other plough, and may be useful in turning down green crops and long dung, as well as in trench ploughing. But in most instances it is thought a preferable plan, where the soil is to be stirred to an unusual depth, to make two common swing-ploughs follow each other in the same track; the one before taking a shallow furrow, and the other going deeper, and throwing up a new furrow upon the former.

2496. *The double share plough* is distinguished by having one share fixed directly over the other. It is made use of in some of the southern districts, with advantage in putting in one crop immediately after ploughing down another, as by it a narrow shallow furrow is removed from the surface, and another from below placed upon it, to such depth as may be thought most proper, it being capable of acting to ten inches or more. In this manner many sorts of crops, such as rye and other green crops that have much height of stem, may be turned down without the inconvenience of any of the parts sticking out through the seams of the furrow slices, by which the farmer has a clean surface of mould for the reception of the grain.

2497. *The mining plough, or trenching plough*, is sometimes employed for the purpose of loosening the soil to a great depth, without bringing it up to the surface, a mode of operation which is particularly useful for various sorts of tap-rooted plants, as well as for extirpating the roots of such weeds as strike deep into the ground. For these purposes it may be employed in the bottom of the furrow after the common plough. It is constructed in a very strong manner, having only a share without any mould-board.

2498. *The double furrow plough* (fig. 286.), is obviously advantageous in performing

285

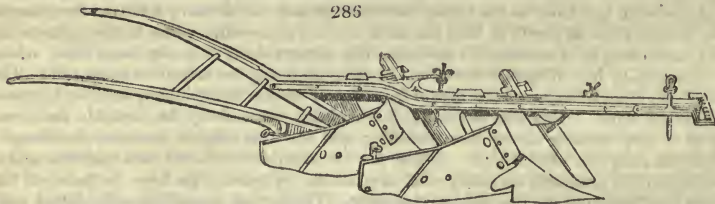

more labor in a given time with a certain strength of team, than other sorts of ploughs, as producing two furrows at a time. It has been found useful on the lighter sorts of land where the ridges are straight and wide, though some think it more confined in its work than those of the single kind. The saving of the labor of one person, and doing nearly double the work with but little more strength in the team, in the same time, recommend it for those districts where four horse teams are in use. This plough has been brought to its present degree of perfection by Lord Somerville, especially by the introduction of the moveable plates already mentioned (2492.), at the extremities of the mould-board, as in his Lordship's single plough. But, as observed by an excellent authority, "with all the improvements made by Lord Somerville, it can never come into competition, for general purposes, with the present single furrow ploughs;" Lord S. admits, that it would be no object to invade the system already established in well-cultivated counties; though, where large teams are employed, with a driver besides the ploughman, it would certainly be a matter of importance to use this plough, at least, on light friable soils. "Their horses," he says, "will not feel the difference between their own single furrow working one acre, or the well constructed two furrow plough, with two acres per day; here is no system deranged, and double work done." (*Communications to the Board of Agriculture*, vol. ii. p. 418.)

2499. *The Argyleshire plough* differs from Small's, or any single swing plough, in having no coulter fixed in the beam, but in lieu of this, a fin or knife rising from the left

side of the share, which serves the purpose of slicing off the furrow as well as the coulter. This fin or feather must be placed at the same angle as the coulter, and should terminate in a lance-like shape, in order to furnish the least obstruction to stubble, weeds, or stones. This plough is not liable to be choaked by stubble, or thrown out by catching small stones between the points of the coulter and sock. It is found particularly useful in taking the earth away from the sides of a drill crop; as its broad upright feather, which operates as a coulter, completely shields the plants from all risk of earth falling on them from the left side of the plough, while, at the same time, the ploughman ascertains, to a certainty, that the part of the plough below ground, approaches no nearer to the roots of the plants, than the upper part does to their leaves; so that he can bring the plough to slice off the earth close in upon their sides, if necessary. In point of draught, it is precisely the same as the common plough.

2500. *The double mould-boarded plough* is a kind of plough often used with advantage in clearing out furrows, in setting potatoes, cabbage, and other similar crops, and in earthing up such as are planted in wide rows. Those whose mould-boards move on hinges, and may be set wide or narrow at pleasure, are the most convenient.

2501. *The ribbing plough* or binot is almost the same thing as the double mould-boarded plough, and the one is commonly sold for the other with no loss to the purchaser. It has two mould-boards, one on each side of the beam: it is used on some soils in forming a ribbed or rigged bed for wheat or other grains, by which when sown broadcast, it comes up in rows. It is also used in earthing up crops; and sometimes, but never by the best cultivators, in giving the first furrow to stubbles,

2502. *The single hoe plough* is also often useful in stirring the mould in the intervals of different sorts of crops, and laying it to the roots of the plants, and thereby preventing the growth of weeds. The mould-board in this plough is so constructed that it can be raised or depressed at pleasure according to the nature of the crop, and the intention with which it is used.

2503. *The marking plough* is used in straightening and regulating the distance of ridges where the drill system is practised. Any plough with a rod fixed at right angles to the beam and a short piece depending from this rod, will trace a line parallel to the furrow drawn by the plough, which line will serve for a guide as to the width of ridges, &c.

2504. *Finlayson's rid plough* is Small's plough, formed of iron with a crane-necked beam rising from the point where the coulter enters it, so as to form an easy curve with the top of the coulter. By this means whatever stubble, roots, or other rubbish the coulter may collect, rises or is forced upwards, follows the curve till coming under the beam it drops, and is either buried in the present furrow, or lies to be interred by the next according to the side on which it drops. It is an implement which may be of use under particular circumstances, but by no means generally.

2505. *Clymer's plough* (fig. 287.), is a recent modification of the implement, formed entirely of iron, and chiefly remarkable for the absence of the coulter, and for the share, mould-board, and other parts which move under ground, being composed of distinct pieces of cast iron; this is considered as cheaper to commence with and easier to repair, because any one part may be renewed of the same material without deranging the rest; whereas renewing or repairing wrought iron shares, mould-boards, or coulters, is found in many districts both difficult and expensive.

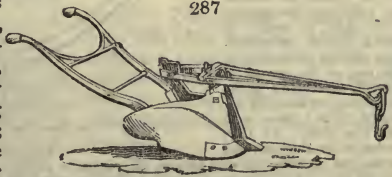

#### SUBJECT. 2. *Wheel Ploughs.*

2506. *Wheel ploughs* in their construction vary considerably in different places, according to the nature of soils and other circumstances; but in every form, and in all situations, they probably require less skill in the ploughman. Wheels seem, indeed, to have formed an addition to ploughs, in consequence of the want of experience in ploughmen; and in all sorts of soil, but more particularly in those which are of a stony and stubborn quality, they afford great assistance to such ploughmen, enabling them to perform their work with greater regularity in respect to depth, and with much more neatness in regard to equality of surface. From the friction caused by the wheels, they, however, give much greater resistance, and consequently demand more strength in the team that is employed; and, besides, are more expensive in their construction, and more liable to be put out of order, as well as more apt to be disturbed in their progress by clods, stones, and other inequalities that may be on the surface of the ground, than those of the swing kind. It is also observed, "that with *wheel-ploughs*, workmen are

apt to set the points of their shares too low, so as by their inclined direction to occasion a heavy pressure on the wheel, which must proceed horizontally:" the effect of this struggle is an increased weight of draught, infinitely beyond what could be supposed: for which reason, the wheel is to be considered as of no importance in setting a plough for work; but passing lightly over the surface, it will be of material aid in breaking up old leys, or ground where flints, rocks, or roots of trees occur, and in correcting the depression of the shares from any sudden obstruction, as well as in bringing it quickly into work again, when thrown out towards the surface. (*Communications to the Board of Agriculture*, vol. ii. p. 419.)

2507. *The Scotch plough, with one or sometimes two wheels (fig. 288.), fixed near to*

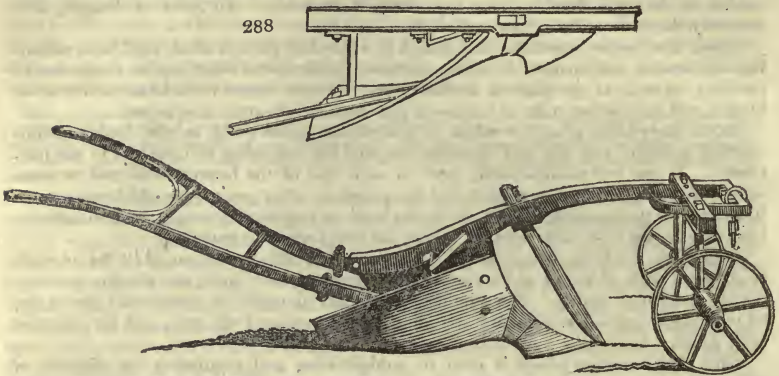

the end of the beam, without any carriage, goes very light, and is very useful; such alterations as are necessary requiring very little time or trouble. Where two wheels are employed, the plough does very well without a holder on a good tilth or light sward, where there are few stones, except at the setting in and turning out. Wheel ploughs should, however, probably be seldom had recourse to by the experienced ploughman, though they may be more convenient and more manageable for those who are not perfectly informed in that important and useful art.

2508. *Wilkie's single horse wheel plough (fig. 289.)* has the wheel (*d*) differently placed. It is adapted for the lightest description of soils, and in them only for the second or subsequent stirrings. The wheel, besides considerably reducing the weight of draught, is found to give a degree of steadiness seldom exceeded in the use of the common plough, excepting when quite new, or recently repaired with a new sock and sole-shoe. At that period, when the back end

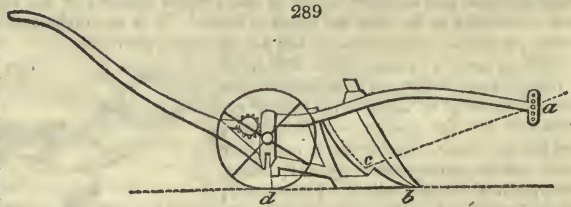

of the sole is quite full and square, the common plough, (when well constructed), goes as well as can be wished for; but, by the great friction of the sole, the back end of it soon becomes convex; and, consequently, the plough loses the steady support of the extremity of the heel, or, in other words, in proportion as the sole becomes more convex, the fulcrum of the lever is extended considerably forward so as to be too near the centre of gravity. When that is the case, the least obstruction at the point of the share throws the plough out of the ground. In order to remedy or counteract that tendency, the ploughman is obliged to raise the point of draught at the end of the beam; but this expedient, although it gives the plough more hold by the point of the share, is attended with another inconvenience fully as bad as the former; for, when the point of the share meets with an obstruction as before noticed, the heel of the plough is raised, on account of the point of draught being fixed above the direct line of attraction. Thus, the common plough, when the sole becomes convex, is made to go very unsteady, and often requires the utmost attention and exertions of the ploughman to direct it. What is stated above, however, can only apply to the common plough when out of order by the sole becoming convex.

2509. *Placing the wheel.* In order to understand in what manner the wheel ought to be placed so as to reduce the friction, it may be necessary to remark, that one of the first properties of a plough is to be constructed in such a manner as to swim fair on the sole. This depends principally on the form of the sole, and position or inclination of the point of the sock, together with the point of draught at the end of the beam (*a*). If these are properly adjusted, the pressure or friction of the sole will be uniform from the point of the share (*b*) to the back end of the heel (*d*); or, in other words, the friction will be balanced between these two points by means of the beam (*a*) acting as a lever, the heel (*d*) being the fulcrum, and a point over the share (*c*) the centre of gravity.

2510. *The centre of gravity* or of resistance will be extended nearer to the point of the share (*b*), in proportion as the soil has acquired a greater degree of cohesion; as in old pasture ground, or strong clays. But wherever the point of resistance meets, it is evident that the point of draught at the end of the beam must be placed, so as to balance the friction of the sole between its extreme points (*b* and *d*). Viewing the machine, therefore, (with regard to the friction of the sole) merely as a sledge carrying a considerable weight, by which it is pressed equally to the bottom of the furrow at the extreme points

(*b* and *d*) it is clear that, by substituting a wheel at the one point (*d*), the one half of the friction of the sole will be thrown on the wheel.

2511. *The draught is reduced by the wheel* from forty to sixty-six pounds, or from one-seventh to one-fifth (two hundred and eighty pounds being the power of one horse). The same application of a wheel has been made by Plenty in some of his ploughs; but as the friction of the wheel is but a small part of the whole friction of the plough, and as in some soils the wheels are very apt to clog without an attached scraper, the improvement has never been much in use either in one or two horse ploughs. Liston, a clergyman, took out a patent for a wheel so applied to a two horse plough (*F. Mag.* vol. xiv.), but it never came into use.

2512. *The Beverston plough* (fig. 290.) was one considered a good wheel plough. It has its principle of draught given it in a very effective manner by an ingenious contrivance of iron work, in which, according to Lord Somerville, "the point of draught is perpendicularly above the point of traction, or the throat or breast where the share fits on."

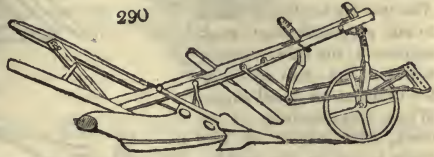

2513. *The Hampshire patent two wheel plough* is nearly the same as the Beverston plough. It is made of iron, and is considered a good implement of the kind. In this manner one or two wheels may be added to any swing plough, and taken away when not wanted without lessening the value of the implement. There is a variety with one wheel and another without any.

2514. *The Kentish and Herefordshire wheel ploughs* are extraordinary clumsy implements of very heavy draught, and making, especially the former, very indifferent work. They were figured by Blythe in the beginning of the seventeenth century, and seem to have received no improvement since. The Kentish plough is generally made with a turn-wrest, in order always to turn land downwards in ploughing a hill; but this, as Lord Somerville remarks, soon renders the summit of the hill or the upper side of the field, where such a practice is persisted in, destitute of soil. A much better mode is to plough up and down the steep, or diagonally across it. In either case the double mould-board plough invented by his lordship, is of singular use, as one furrow only need be taken in going up and two in coming down.

2515. What is called the *pressing plough* is more properly a roller, being a cast-iron wheel or narrow roller fitted to a frame and shafts, and drawn like a common roller by one horse. Sometimes two such wheels are applied on one axle, which is preferable. This implement is used to roll clover leys broken up for wheat: two ploughs follow each other, and after them, one horse with the two pressing wheels, which press down the two furrows turned by the plough. The advantages of the operation are said to be, that a finer bed is thus prepared for the seed, which is covered by a very slight harrowing, and also the wire-worm is said to be kept under by the consolidation of the surface. Its use is chiefly confined to the west of England.

291



2516. *The Norfolk wheel plough* (fig. 291.) has a clumsy appearance from the great bulk of its wheels, and their carriage, but in light friable soils it does its work with neatness, and requires only a small power of draught.

2517. *The paring plough* is of various forms, though it is an implement seldom required. It is used for paring the surface of old grass lands, or leys on clay soil, where the turf is to be burned. A variety in use in the fen districts (fig. 292.), has a wheel (*a*) which cuts the turf instead of a coulter, a broad flat share which raises it, with a sharp fin or turned-up part at the extremity, which cuts the turf on that side, thus turning it over in slices about a foot broad, and two inches deep. There is a foot (*b*) from the forepart of the beam, which serves as a wheel, to prevent the share from going too deep.

292

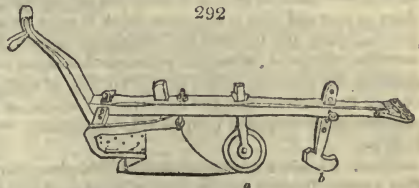

2518. *Draining ploughs* are of various kinds, but none of them are of much use; the work can always be done better, and generally cheaper, by manual labor.

293



2519. *Clarke's draining plough* (fig. 293.) was found to answer well in meadow ground near Belford in Northumberland, but could not be drawn in stiff clay with the force of eight horses.

2520. *Grey's draining plough* (fig. 294.) seems one of the best. The beam is strongly fortified with iron, and is always kept at a proper distance from the surface of the ground, and also the depth of the drain regulated by two wheels (a a) which turn on an iron axle, and roll upon the surface on each side of the drain. The middle coulter is made to cut perpendicular; consequently, the side coulters will cut the two sides of the drain at an equal slope. When this machine is at work, the earth of the drain is cut in the middle by the foremost coulter, and on each side by the other two coulters. Then the sharp point of the share

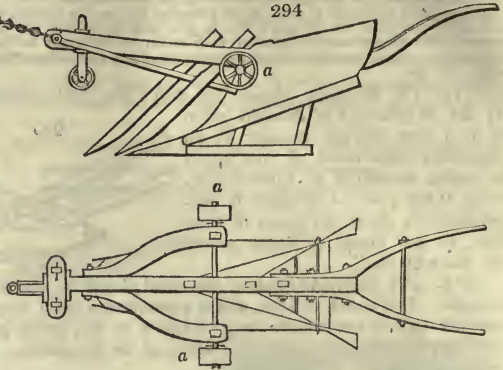

will cut up that earth from its bed, and as the machine advances, it must ascend on the surface of the inclined plane; at the same time, the fore-ends of the mould-boards, following in the track of the middle coulter, will divide the slice of earth as it rises, into two equal parts, turning these parts gradually to each side; and as the back-ends of the mould-boards extend farther than the breadth of the drain above, the portion of earth so raised will be placed upon the firm ground, leaving the drain quite open. The frame into which the axle is fixed, may easily be either raised up or depressed, according as the drain is to be cut deep or shallow; and the two outside coulters can easily be placed more or less oblique, so as to cut the sides of the drain at a greater or less slope, as may be found necessary. (*Grey's Implements, &c.* 4to.)

295

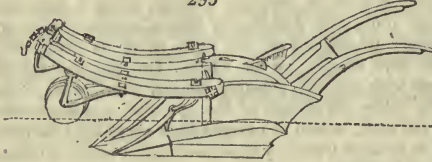

2521. *The gutter plough* (fig. 295.) is made use of for forming gutter drains in grass lands, where the soil is of a retentive nature. The power of six horses is required in drawing it for the first time; but four horses are found sufficient for opening the old gutters.

was invented by Adam Scott, and improved by Lumbert of Gloucestershire. It is said to be an implement which in ductable soils and situations, as in pleasure-grounds, and where much regard is had to the surface-appearance of the land, may be of considerable benefit in forming temporary drains. It makes a drain without opening the surface any more than merely for the passage of a thin coulter, the mark of which soon disappears: it is chiefly employed in such grass-lands as have a declination of surface, and where there are not many obstructions to contend with; but some think it may be used in other kinds of land, as on turnip-grounds that are too wet for the sheep to feed them off, or where, on account of the wetness, the seed cannot be put into the earth. With this plough the drains should be made at the distance of ten or fifteen feet in straight lines, and also contrived so as to discharge themselves into one large open furrow, or grip, at the bottom of the field. As it requires great strength to draw this implement, it can only be used where a good team is kept.

2522. *The mole plough* (fig. 296.)

296



2523. *Lumbert* not only brought this plough to its present shape, but finding the surface greatly injured by the feet of so many horses as were found necessary to draw it, he invented a piece of machinery (fig. 297.) consisting of a windlass, frame, and anchor, by which it is worked by the labor of four men. Young, and other members of the Board of Agriculture, expressed themselves greatly enamoured of this plan; but it is obviously too complicate and expensive for general use.

2524. *A subsequent improvement*, by *Lumbert*, consisted in the addition of a ginwheel and lever, by which the machine was worked by one horse walking round it, as in a common horse-mill; and this last form has again been improved by the late mechanist, *Weir*, of Oxford-street, London, by the addition of a vertical cylinder, which winds up the chain,



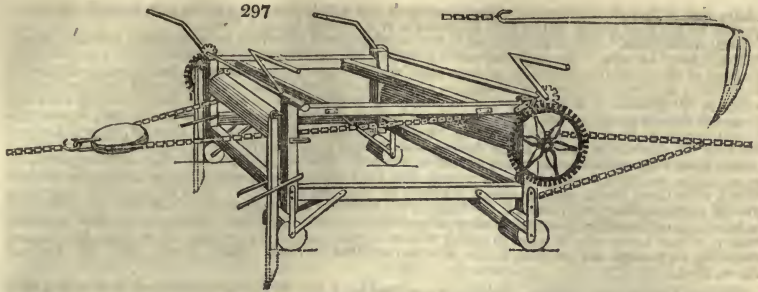

without any attention from the driver. Weir has also simplified and strengthened

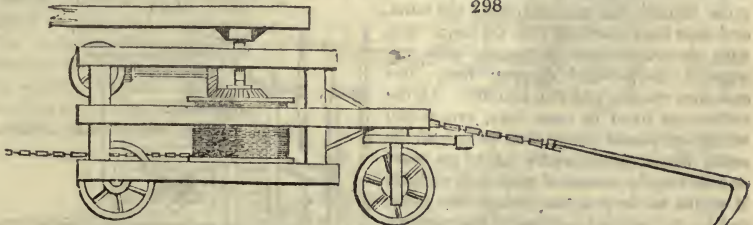

this machine in other respects, so that his modification of it (*fig. 298.*) is, at present, by far the best. Still we think it an implement that very seldom can be profitably used; that this may be the case, the surface of the field must have a natural drainage, by lying in one even slope or slopes: it must be in pasture, and the soil must be of uniform consistency, and free of stones. But even where these favorable circumstances combine, we think two swing ploughs, with finless shares, following in the same tract, would effect the same object sufficiently well for all agricultural purposes; and for drains in ornamental grounds, no machine will ever equal manual labor.

2525. *Various draining ploughs* have been invented and tried by Arbuthnot, Makie, M'Dougal, and others, but they have never found their way among practical men.

2526. *The only essential plough* to be selected from these three sections, is the Scotch swing plough, with or without one or two-wheels, according to circumstances, and with the share and coulter set to suit different soils, as flinty, chalky, gravelly, &c., or soils in different states of culture, as old turf, ley, fallow, &c.

### SUBSECT. 3. *Of the Tillage Implements, known as Scarifiers, Scufflers, Cultivators, and Grubbers.*

2527. The use of *pronged implements* as substitutes for the plough, is comparatively of recent invention. They differ from the plough, in stirring the soil without reversing its surface or altering its form, unless, indeed, they in some cases tend to even or level inequalities; they act both as the plough and harrow at the same time, and on suitable soils, and at proper seasons, much more labor is effected with less expense of men and cattle. Wherever therefore lands require to be stirred for any purpose, excepting that of reversing the surface, or laying them into beds or ridges, recourse may be had to pronged tillage implements, such as we are about to describe.

2528. *In estimating the value of pronged tillage implements*, General Beatson (*New System of Cultivation*, 1820.) applies the principle of lessening power and employing time. He says, if we apply the principle of petty operations to any stiff land, by taking that depth of furrow which can easily be ploughed with two horses, and repeat the operation, (or plough the land a second time,) we shall arrive at the end proposed, that is, the same depth of ploughing, with absolutely less exertion of animal strength, than if we were to plough the same depth with four horses at one operation.

2529. This may be *illustrated* by supposing the resistances to the plough to be in proportion to the squares of the depth of the land. If so, and we are to plough at once with four horses, six inches deep, the resistance at that depth would be  $6 \times 6 = 36$ ; but if with the same four horses, using two at a time, we plough the same depth of six inches at two operations, taking only three inches at each, then the square of the first depth is nine, and the square of the second, nine—making 18 for the total resistance, or the power expended by the two horses, in ploughing six inches deep, at two operations.

2530. *A farther illustration* may be made by supposing the same four horses, which had ploughed at once six inches deep, and had overcome the resistance of  $6 \times 6 = 36$ , applied, separately, to four light ploughs, or other implements, and to plough only  $1\frac{1}{2}$  inch deep at a time, and to go over the same land four times. In this case the sum of all the resistances to be overcome, or the animal force expended, in these repeated ploughings, would be no more than 9 instead of 36; because the square of  $1\frac{1}{2} = 2\frac{1}{4}$ , which multiplied by the four ploughings, gives 9, or only one fourth of the power expended in ploughing at once six inches deep. Hence, it appears, that in ploughing six inches deep, with four horses, each horse exerts a force = 9; whereas, in taking only  $1\frac{1}{2}$  inch deep, the force he exerts is not more than  $2\frac{1}{4}$ .

2531. *Farther*, supposing that a horse exerts, in drawing a plough, a force of 160 pounds, it is evident if four horses are ploughing six inches deep, the total force exerted will be 640 pounds, or 160 pounds by

each; but if they be required to plough one inch and a half deep at a time, then the total force expended by the four horses will be only 160 pounds, or 40 pounds by each horse.

2532. *Application.* This leads General B. to the principle on which his small scarifiers are constructed. "They have," he says, "four hoe-tines in the hind-bar, and I will suppose that there are four harrow-tines (instead of three) in the front bar, so that each scarifier may be considered as four small ploughs, with four shares and four coulters. If we suppose one horse attached to this implement, and that the force he exerts is 160 pounds, it is obvious that in scarifying to the depth of one inch and a half, he will exert these 160 pounds upon the four pairs of tines, or a force of 40 pounds upon each pair. But, in fact, the force required to draw the scarifier will be considerably less than to draw any form of plough, because the hoe, or share-tines, being much thinner and sharper than a plough-share and mould-board, will of course meet with much less resistance in stirring the soil. General B. goes on to relate some experiments by which he considers he has "clearly proved that the least expensive method of preparing the land for wheat, after tares, beans, peas, or clover, is simply by using the scarifiers." This we conceive is carrying the use of the scarifier much too far. We think it is a sufficient illustration of its value that it may be used in stirring lands on which potatoes or turnips have grown, or that has been ploughed in autumn or during winter, so that a crop may be sown in spring without farther use of the plough. In working fallows, and preparing for turnips and potatoes, it may save two or three furrows. (*Supp. Encyc. Brit. art. Agr. and Farm. Mag.*)

2533. *The Scotch scarifier, cultivator, or grubber (fig. 299.)* is considered one of the best implements of this kind as a substitute for the plough. It consists of two strong rectangular frames, the one including the other,

299

and nine bars mortised into the inner one, with eleven coulters or prongs with triangular sharp-edged dipping feet, four cast-iron wheels, and two handles. All the cutters are fixed in these bars, except two which are placed in the side beams of the outer frame, and may be set to go more or less deep by means of pins and wedges. It works as deep as the plough has gone, and by the reclined position of the coulters, brings to the surface all the weed roots that lurk in the soil. Beans and peas have been sown in spring on the winter furrow, after being stirred by the grubber; and barley also after turnips, without any ploughing at all. This implement is made of different sizes, and may be worked either by four or by two horses, and one man.

2534. *Weir's improved cultivator (fig. 300.)* is a very effective implement of this kind,

300

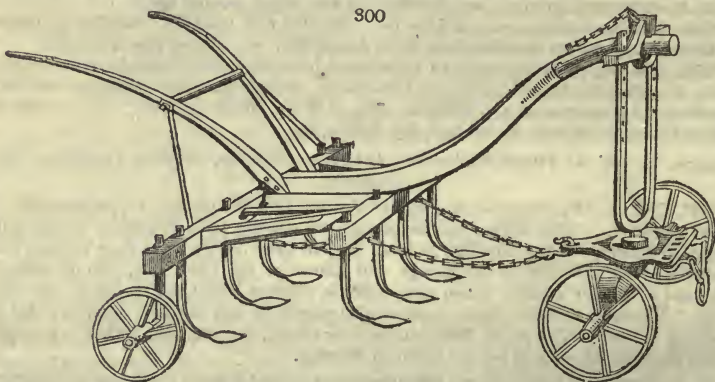

with nine coulters or prongs. It may be set to go more or less deep by raising or lowering both the fore and hind wheels.

2535. *Parkinson's cultivator (fig. 301.)* has been found a very useful implement, both for stirring and cleaning land. Its inventor recommends that where the land is foul from couch, sods, or any other cause, the number of teeth or hoes should be reduced to five or seven, two or three being placed in the fore bull, and four in the hindermost, increasing them to nine as the land becomes in a fine condition.

301

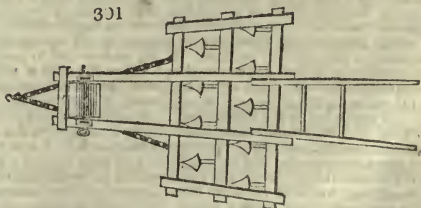

2536. *The chain by which this cultivator or scarifier is drawn;* enables the person that holds it to work it better, than if it were drawn by a beam like a plough, and occasions also less draught by the power being nearer to the claws; the machine goes more freely than it would if some of the claws were in the fore bull, the sole use of that bull being to draw by. When the scarifier was made in a triangular form and with the same number of claws, it was apt to go on its head, or by raising the hindmost claws out of the ground to work frequently at one corner only. The claws are formed at the bottom with a point, so as to push a stone out of the way before the broad part can meet with any obstruction, which makes the machine cut with much greater ease. As to their width at the foot, they may be made to cut all the land more clearly than a plough if required, where thistles, fern, &c. grow, and the claw is so formed by its crooked direction as to raise every obstruction to the top, rock excepted.

2537. *Hayward's cultivator* (fig. 302.) or, as it is called, extirpator or scalp plough, is used on land already ploughed. Its hoes or scalps are intended to pierce about two inches at each operation, so that by repeatedly passing it over the surface, the land will be stirred as deep as the plough has gone.

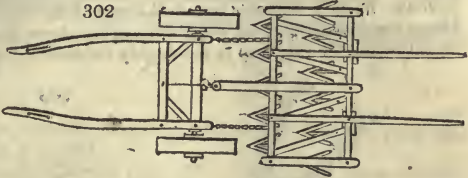

2538. *Beatson's cultivator* (fig. 303.) is recommended by the inventor for its lightness: it is intended, as before observed (2532.), to effect by reiterated application what is done by the large Scotch cultivator at once; by which means a saving of power is obtained, but a loss of time, as is usual in all similar cases.

303

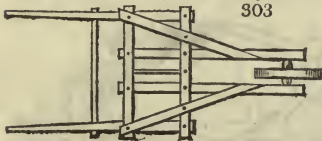

SUBJECT. 4. *Of Tillage Implements of the Hoe Kind.*

2539. *Of horse hoes* there is a great variety, almost every implement-maker having his favorite form. They are useful for stirring the soil in the intervals between rowed crops, especially turnips, potatoes, and beans. Respecting the construction of horse hoes it may be observed that soils of different textures will require to be hoed with shares of different forms, according to their hardness, or mixture of stones, flints, or gravel. The number of hoes also in hard soils requires to be diminished; in the case of a stony clay, one hoe or flat share, with or without one or two coulters or prongs, will often be all that can be made to enter the ground. In using these implements, the operator should always consider whether he will produce most benefit by merely cutting over or rooting up the weeds, or stirring the soil; because the hoe suited for the one purpose is by no means well adapted for the other. In the former case flat shares are to be preferred, but pointed, that they may enter the soil easily; in the latter coulters or prongs, as in the cultivators, are much more effective, as they will enter the soil, and stir it to a considerable depth, thus greatly benefiting the plants by the admission of air, heat, dews, and rain, and by rendering it more permeable by the roots.

2540. *The Scotch horse-hoe* (fig. 304.) has three hoes or shares, and is drawn by a single horse. By means of the wheel it can be set to go to any depth, and in hard surfaces, one or more of the shares can be taken out, and coulters or bent prongs, as in the cultivator (fig. 300.), substituted.

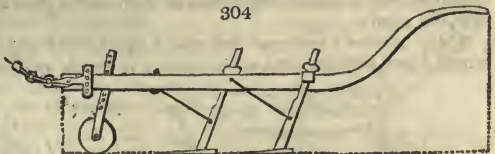

2541. *The Northumberland horse-hoe* (see Report, &c. p. 43.) is of a triangular form, and contains three coulters and three hoes, or six hoes, according to the state of the soil. In

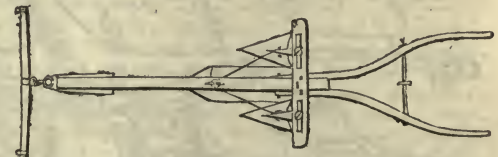

hoeing between drills of turnips, the two side coulters are used of a curved form. A hoe of the same kind is sometimes attached to a small roller, and employed between rows of wheat and barley, from nine to twelve inches distant; it is also used in place of a cultivator, in preparing bean stubbles for wheat in autumn, and in pulverising lands for barley in spring.

2542. *Wilkie's horse-hoe and drill-plough* is considered an effective implement. The mould-boards are taken off when used as a horse-hoe, and the hoes taken off and the mould-boards replaced, when earthing up the crops; thus combining, in one implement, a complete horse-hoe and double mould-board plough. A good horse-hoe being the principal object in the construction of this implement, the method of fixing the hoes claimed particular attention; in order to combine lightness with strength and firmness, and admit, at the same time, of being set at different degrees of width and depth; all of which are accomplished on an improved principle. The wheel at the point of the beam regulates the depth; the right and left hoes are hinged, at the back end, to the handles of the plough, while by moving on the circular cross bar, on which they are fastened with wedges, they may be set to any width, from about twelve to nearly twenty-four inches.

2543. *Wilkie's horse-hoe and drill-harrow* (fig. 305.), is intended to be introduced between the drills as soon as the plants appear above ground, and the operation is repeated at intervals, till the crop is thoroughly cleaned. The centre hoe is stationary, and the

305

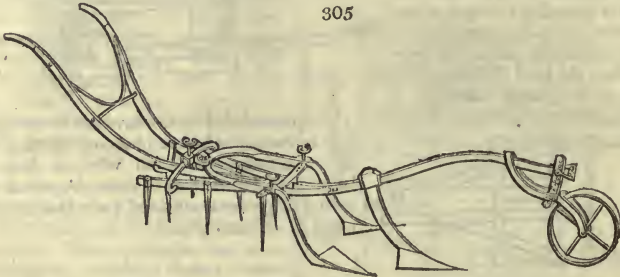

right and left expand and contract in the same manner as in the horse-hoe. The depth is regulated by the wheel at the point of the beam, and may be varied from one to six inches. The hoes cut the bottom of the space between the drills completely, while the harrow following, pulverises the soil, and rakes out the weeds. Should circumstances require, the wings of the harrow may be taken off, and the hoes only used; or the hoes displaced, and the harrow only employed.

2544. *Blaikie's inverted horse-hoe* consists of a line of coulters set in a beam, and this beam attached to the axle of a pair of common wheels. It hoes several rows at once, and instead of being straight the coulters are all curved or kneed, and set back to back so as to include a row between each pair. The advantage of the kneed or bent form of the lower part of the coulter is, that the soil is pared off in a sloping direction from the plants, which are thus not so liable to be choked up with earth as by a broad hoe or share; or to have their roots so much exposed to the air as by cutting perpendicularly down close to the row by a common coulter. It is chiefly adapted for drilled corn, and then it works several rows: in turnips it may work one or two according to the soil; in all cases where the width between the rows admits, the agricultor should be more anxious to stir the soil to a good depth than to skim over a great extent of surface, merely cutting over the weeds.

2545. *Morton's universal drill plough and harrow* (fig. 306.) answers both as a double mould-board plough, and a horse-hoe; is much approved of in the culture of drilled

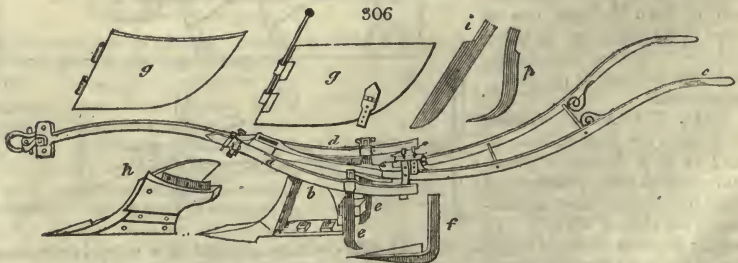

crops; and with some slight attentions it may be also employed as a small plough for taking the earth from the sides of the ridglets. When it is used as a horse-hoe, the mould-boards are taken off, and two curved cutters or coulters, expand from the beam on

each side to a less or greater distance according to the width of the interval between the plants, and approach each other in the bottom of the furrow where the share supplies their place. This machine is well adapted for light soils, and can be set to work very near the rows of plants; it is particularly useful in cutting up annual weeds preparatory to hand-hoeing, which it greatly facilitates. When it is to be employed as a single or double mould-board plough, the cutters are withdrawn.

2546. A double mould-board plough is formed of this implement, by applying its two mould-boards (*g, g*); and a paring plough by applying the expanding wings (*b, d*), and curved coulters (*p*); a scuffler is formed by applying two scufflers (*f*) in places of these coulters; a drill harrow by adding a triangular frame with tines (*fig. 307.*), and which may be rendered in effect a brake harrow by increasing their size, or a horse-hoe by substituting hoes (*k, k, k*). Lastly, it may be rendered a paring plough by substituting a suitable body and share (*h*). (*Supp. Encyc. Brit. vol. i. p. 200.*)

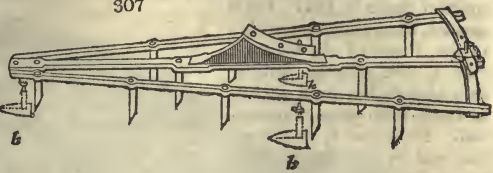

2547. Amos's expanding horse-hoe and harrow (*fig. 308.*) is said to be much used in Lincolnshire. The hoe is constructed with expanding shares (*a, a*), which can be set to

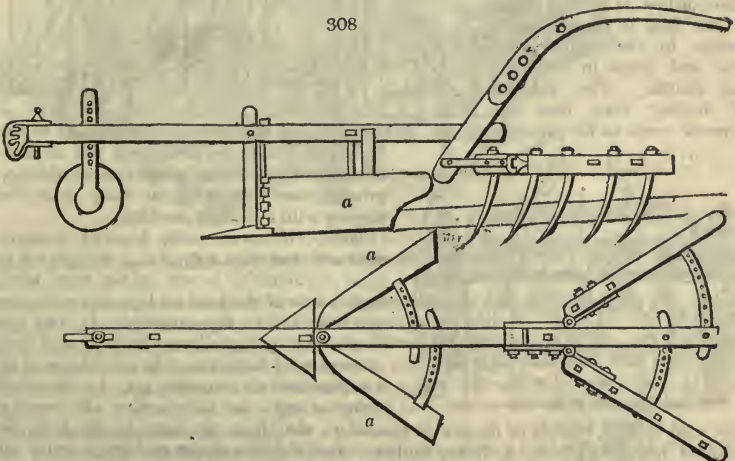

different distances as may be required, within the limits of twelve and thirty inches. The harrow which is attached to it, is found advantageous in clearing lands from successive crops of weeds, as well as in bringing them to a proper state for the purpose of cropping; serving in this respect as a cultivator.

2548. The hoe and castor wheel (*fig. 309.*) is said to enable the holder to guide the shares more correctly between narrow rows of corn drilled on a flat surface. It is not often required, and must be unnecessary if the rows have been correctly sown.

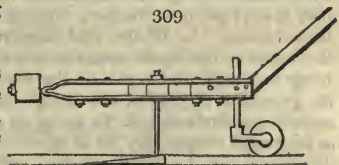

2549. The thistle hoe or hoe scythe (*fig. 310.*) is an invention by Amos. "It is used," he says, "for the purpose of cutting over thistles, and other injurious weeds in pasture lands. In the execution of the work it not only greatly reduces the expense, but executes it in a much closer manner than by the common scythe. One man and a horse are said to be capable of cutting over twenty acres in a day. The leading share (*a*) is made of cast steel, in the form of an isosceles triangle, whose equal sides are fourteen inches long, and its base twelve inches; it is about one eighth of an inch thick in the middle, tapering to a very fine edge on the outsides; and the scythes (*b, b, b*) are fixed to four pieces of ash wood, three inches square, and two feet four inches long. These scythes are three feet long from point to point, four inches broad at the widest part, and made of cast steel. The agriculture, where such a machine as this is wanted, must surely be of a very rude and imperfect kind; for even supposing the machine to cut over the thistles, that operation cannot be so effectual as cutting them under the collar by hand with the spade or spud.

2550. The only essential machine of this class is the hoe plough of Wilkie; or any other similar one.

SECT. II. Of Machines for Sowing and Planting.

2551. Machines for sowing or planting in rows, are very various and often too complicated. Harte says, the first drill machine was invented by a German, and presented to the court of Spain in 1647; but it appears, from a communication to the Board of Agriculture, that a sort of rude drill or drill plough has been in use in India from time immemorial. Their use is to deposit the seed in equidistant rows on a flat surface; on the top of a narrow ridge; in the interval between two ridges; or in the bottom of a common furrow. Corn when drilled is usually sown in the first of these ways; turnips in the second; and peas and beans in the third and fourth. The practice of drilling corn does not however seem to be gaining ground, and even where it is found of advantage to have the plants rise in parallel rows, this is sometimes done by means of what is called ribbing, a process more convenient in many cases than sowing with a drilling machine.

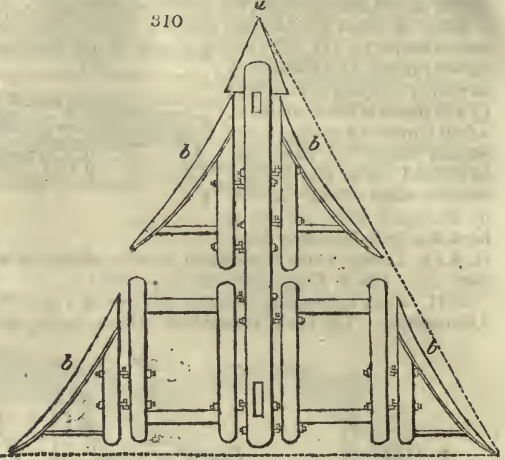

311

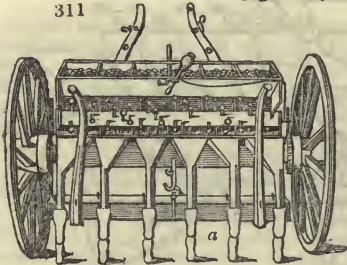

any road without trouble or danger of breaking; also from the farm to the field, &c. without taking to pieces. 2. In the coulters, moving with great ease, on the principle of the pentagraph, to the right or left, so as to counteract the irregularity of the horse's draught, by which means the drills may be made straight: and where lands or ridges are made four and a half, or nine and a half feet wide, the horse may always go in the furrow, without setting a foot on the land, either in drilling or horse-hoeing. 3. In the seed supplying itself regularly, without any attention, from the upper to the lower boxes as it is distributed. 4. In lifting the pin on the coulters-beam to a hook on the axis of the wheels; by which means the coulters are kept out of the ground at the end of the land, without the least labor or fatigue to the person who attends the machine. 5. In going up or down steep hills, in the seed-box being elevated or depressed accordingly, so as to render the distribution of the seed regular; and the seed being covered by a lid, and thus screened from wind or rain. The same machine is easily transformed into a cultivator, horse-hoe (fig. 312.), scarifier, or grubber, all which operations it encounters exceedingly well; and by substituting a corn-rake, stubble-rake, or quitch-rake, for the beam of coulters, or hoes (a), it will rake corn-stubbles, or clean lands of root weeds. When corn is to be sown in rows, and the intervals hoed or stirred, we know of no machine superior to this one, and from being long in a course of manufacture, few can be made so cheap. But these advantages, though considerable in the process

312

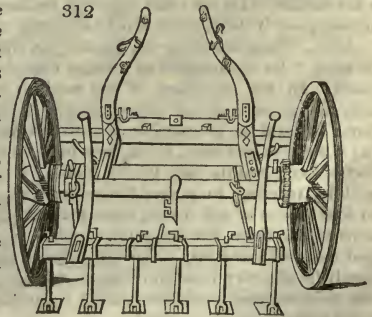

of drilling, are nothing, when compared with those which arise from the use of the horse-hoe; with which from eight to ten acres of land may be hoed in one day, with one man, a boy, and one horse, at a trifling expense, in a style far superior, and more effectual, than any hand-hoeing whatever; also at times and seasons when it is impossible for the hand-hoe to be used at all.

2553. *The Norfolk drill* or improved lever drill (*fig. 313.*), is a corn drill on a larger scale than Cooke's, as it sows a breadth of nine feet at once: it is chiefly used in the light

313

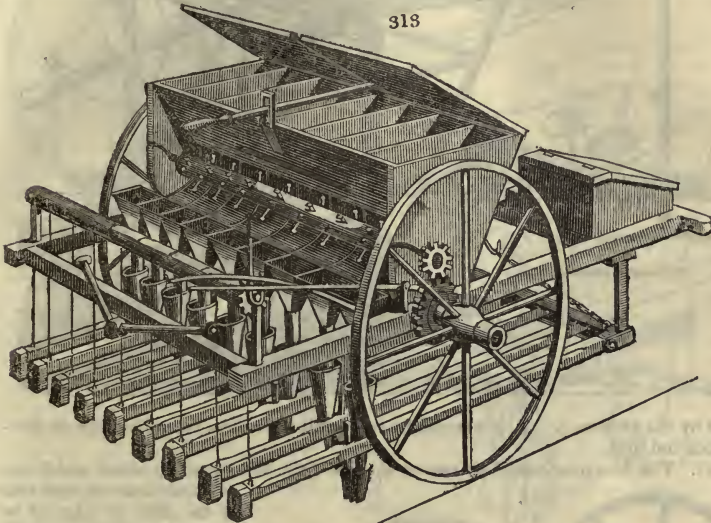

soils of Norfolk and Suffolk as being more expeditious than Cooke's, but it also costs about double the sum.

2554. *Cooke's three row corn drill* is the large machine in a diminutive form, and is exceedingly convenient for small demesne farms where great neatness is attended to. It can be used as a cultivator, hoe, rake, &c. like the other.

2555. Of *turnip drills*, the best, when this root is cultivated on a large scale, is the improved Northumberland drill (*fig. 314.*). The roller (*a*) which goes before the seed has two concavities, and thus leaves the two ridges in the very best form for the seed (2473.); after these are sown, two light rollers (*b, b*) follow and cover them. It is drawn by one horse, sows two rows at once, and seldom goes out of repair.

314

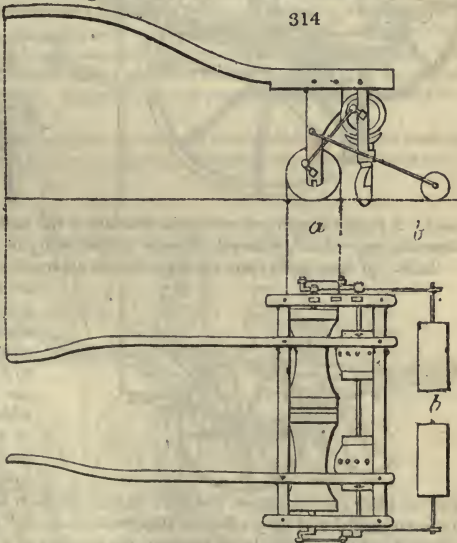

2556. *French's turnip drill* (*fig. 315.*) is the most perfect implement of the kind. French was a Northumberland mechanist, and invented the concavities in the turnip rollers (2473.); soon after which he died, and it was some time before his invention attracted notice.

Concave rollers, however, and curved coulters may be considered as two of the greatest improvements that have been made in the machines used in turnip culture since that root was first cultivated in drills. Besides the improvement of the concave rollers, this machine is easily put in and out of gear by means of a lever (*a*); and since it has become the fashion to sow pulverised manure with turnip seed, two hoppers (*b, b*) have

been added for that purpose. The seed and manure, when deposited in the gutter

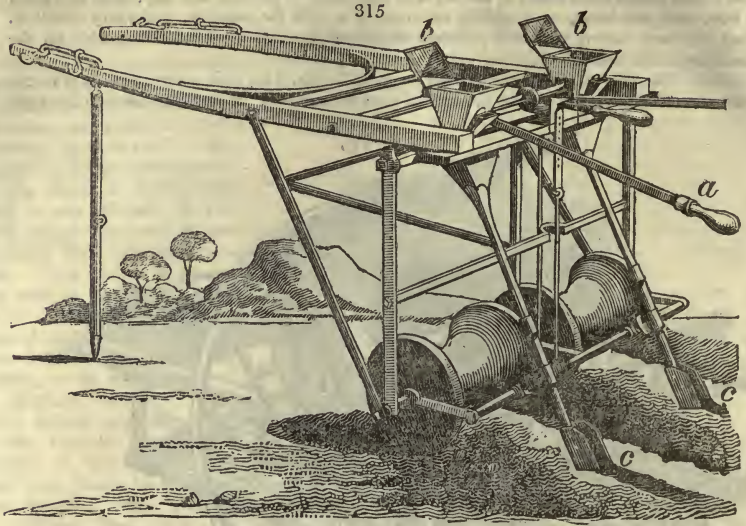

traced by the coulters (c, c), is covered by two small flat rollers as in the common Northumberland drill.

2557. The Northumberland one row turnip drill (fig. 316.) has two wheels which run

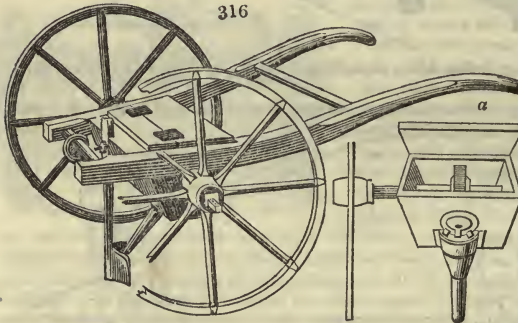

in the hollows on each side of the drill or ridge to be sown; by which means the sower is enabled to keep the row exactly in the centre of the drill. The ridges are previously rolled, either by a common or concave roller; the latter being preferable, and as the horse goes in the furrow at one side of the drill to be sown, of course he draws from one side of the draught-bar of the barrow. A small roller follows, and covers and presses in the

seed. A recent improvement in this machine is the addition of a hopper (a), for pulverised manure, over which, a barrel of water might easily be suspended if deemed requisite.

2558. Of bean drills there are three kinds, all equally good: one for sowing in prepared

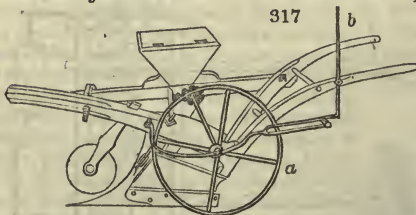

drills or after the plough, which is pushed by manual labor, and has been already described (2469.): one attached to a light plough, which draws a furrow in prepared soil and sows a row at the same time (fig. 317.); and one which can be fixed between the handles of any common plough for the same purpose. The former has a wheel (a) to regulate the depth of the furrow,

and a lever (b) to throw the drill out of gear on turning at the ends of the ridges. It is an useful and very effective implement; though a skilful ploughman will effect the same object by a drill placed between the handles of a common swing plough.

2559. Weir's expanding bean drill to sow four rows, is affixed to a pair of wheels and axle, in the manner of Cooke's drill. The axle which passes through the drill boxes has four moveable brushes and cylinders, by which means any widths, within that of the axle, can be given. Where ground is prepared and ribbed, and where there is not a Cooke's drill on the premises, this machine may be resorted to with convenience.



2560. *Weir's manuring one row turnip drill* (fig. 318.) is a remarkable improvement

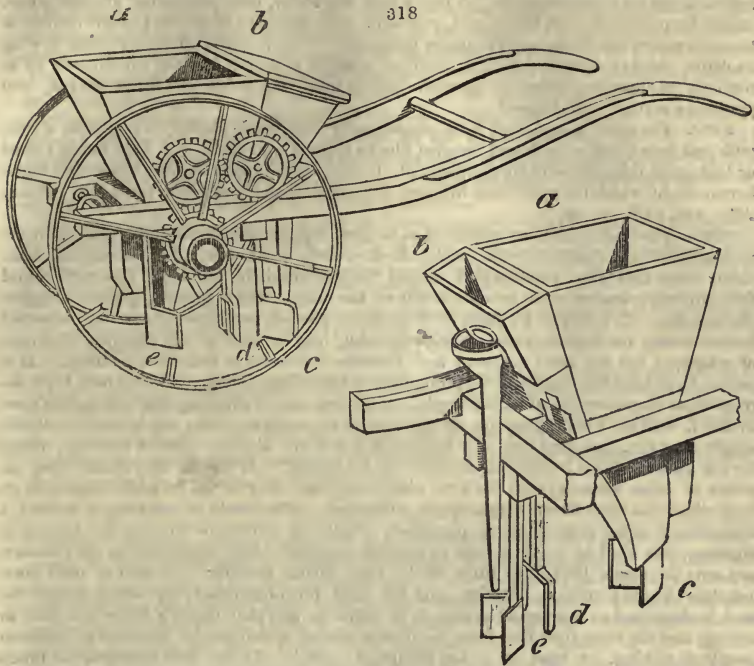

on the Northumberland implement. It has a manure hopper (*a*) and a seed hopper (*b*), the same as the other; but the manure, in place of being dropped along with the seed, is deposited in a deep gutter, made by a couler (*c*) which goes before; this manure is covered by a pronged couler (*d*) which follows the other; next comes the couler which forms the gutter for the seed (*e*). The seed is thus deposited about one inch above the manure. One roller of the concave kind goes before the machine, and another light one of the common kind follows after it: or without attached rollers, the drill may be affixed to one side of the common roller behind, which roller may prepare one drill and cover the seed sown on another each course.

2561. *A machine for dibbling beans*, impelled by manual labor, has been already noticed (2469). A horse dibbling machine (fig. 319.) has been invented, though very little used,

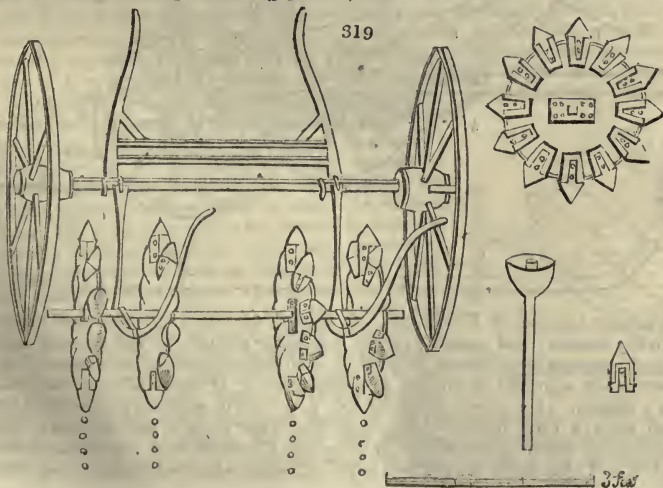

and being rather complicated in its movements, it will require considerable simplification before it can be recommended. A heavy cast iron roller, with protruding angular rings, might form drills for the beans, and, probably, some machine of this sort might distribute them singly or nearly so, and at regular distances. But the best cultivators prefer sowing in drills, thicker than in dibbling, in order to admit of a wide interval for culture, so as not only to clean the surface as between dibbled rows, but to stir and work the soil, and produce a sort of semi-fallow.

2562. *The block plough drill* is an equiangular triangular block, 30 inches to a side, with cast iron scuffler teeth and wooden blocks slipped over them. A field being ribbed or laid up in ridgelets with this implement, is next sown broadcast with wheat and bush-harrowed, by which the grain rises in rows, as accurately as if sown with the drill. (*Farm. Mag.* vol. xxiii. p. 406.)

2563. *The drill roller* is so contrived as to form regular small incisions or drills in the ground at proper depths for the seed. It is merely a common roller mostly of iron, about seven feet long, about which are put cutting-wheels of cast iron, that turn round the common cylinder, each independently of the others, which cylinder generally weighs about a ton. It is drawn by three or four horses abreast, and driven by a man elevated behind them; the cutting-wheels being moveable, may be fixed at any distance, by means of washers; but the most common and favorite distances is four to six inches. It is said to have been found effectually productive of the principal benefits which have been derived from the operation of drill-ploughs, or the practice of dibbling and setting the corn by hand, with the great advantage of saving both time and expense; as, by the use of this simple machine, one man may sow and cover five or six acres of corn in one day, using for the purpose three horses, on account of its weight. It was at first chiefly used on clover or other grass-leys on the first ploughing, but may be as properly employed on land which has been three or four times ploughed. The mode of working it is this: a clover-ley or other ground being ploughed, which the cultivator intends for setting or dibbling, this kind of roller is used to save the expense. It is drawn across the furrows, and cuts the whole field into little drills, four inches asunder; the seed is then sown broadcast in the common quantity, and the land bush-harrowed; by which means the seed is deposited at one equal depth, as in drilling, and that depth a better one than in setting, and the crop rises free from the furrow-seams, which are the ill effects of common broadcast sowing, at least on a ley ploughed once." To us this machine, so much praised by some writers, seems merely an ingenious mode of increasing the expenses of culture. By the use of a plough, such as Small's, that will cut a square furrow, no machine of this sort can possibly become necessary. The land when ploughed will be left in little drills, and being sown broadcast, the seed will come up as if it had been drill-rolled or ribbed. It is admitted, however, that the pressure of the roller may be useful in soft lands, and may, possibly, as already mentioned (2515.), keep down the wire-worm.

2564. *The drill watering machine* (fig. 320.) is an implement of recent invention by

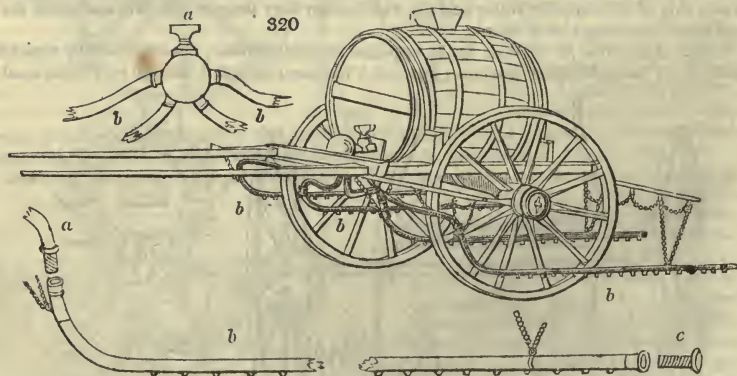

John Young, a surgeon, in Edinburgh. It is used for watering turnips and other drill crops in dry seasons; and promises to be a valuable addition to the amateur agriculturist, in dry seasons or situations, or where it is an important object to secure a crop. It has been much approved of by the Highland Society of Scotland and the Dalkeith Farmer's Society. (See *Farm. Mag.* vol. xxi. p. 1.) The machine consists of a barrel, mounted upon a cart frame, which discharges water from a ball stop-cock, having four mouths (a) which communicate by means of a leathern hose, with four horizontal tubes (b, b, b, b), shut up at the end by a screw (c), which admits of the tube being cleaned.

The tubes are placed parallel with the drills, two between the wheels of the cart, and one on the outside of each wheel; the distance of the tubes, and their height from the surface, is regulated by hooks and chains; and the water is discharged in small streams, through twenty projecting apertures in the under part of the tubes. The tubes are suspended by chains to the hooks in an iron rod, secured to the fore and back part of the frame of the cart. The mouth of the funnel on the top of the barrel, is covered with a wire-cloth, to prevent any thing getting in to clog the apertures. As the quantity of water let out by the apertures is less than what is received into the tubes, the tubes are always full; by which a regular discharge is kept up from all the apertures at the same time. As the machine advances, the stream which falls from the first aperture upon the plants, is followed up by a stream from all the apertures in the tube; therefore each plant must receive all that is discharged from twenty apertures.

2565. *Estimate of its operation.* Supposing the barrel to contain 200 gallons, and the tubes to be five feet long, the diameter of the tubes three-eighths of an inch, and the diameter of the apertures in the tubes to be one-sixteenth of an inch, 200 gallons will be discharged from 80 such apertures in two hours one-third. The diameter of the mouths of the stop-cock must be equal to the diameter of the tubes. The horse going at the rate of  $2\frac{1}{2}$  miles in one hour, in two hours and twenty minutes will go 5 miles five-sixths. The distance between four drills is 6 feet 9 inches; therefore, if we suppose a parallelogram to be 6 feet 9 inches broad, and 5 miles five-sixths long, the area of this parallelogram will be 4 acres 3 roods 1·6 perches, which will be watered by 200 gallons in two hours and twenty minutes; and in one hour it will water 2 acres 7·27 perches, supposing the water to flow uniformly; but the quantity given out upon the drills must be regulated by the progressive movement of the machine.

2566. *In construction* it is neither complicated nor expensive; it may be erected upon the frame of a cart used for other purposes in husbandry; and the barrel and apparatus may be furnished for about six pounds sterling, supposing the stop-cock and connecting-screws to be made of brass, and the tubes of copper or tin. This machine may be used for other purposes; such as the application of urine as a manure, or of a solution of muriate of soda, which has been proposed for some crops.

2567. *The essential drill machines* are French's for turnips, Cooke's for corn, and the drill attached to a plough (2558.) for beans.

### SECT. III. *Of Harrows.*

2568. *The harrow is an implement of equal antiquity with the plough*, but it does not appear to have undergone so much improvement as that implement; nor, indeed, is it capable of so much. The chief circumstances in which harrows have been rendered more applicable and convenient, seem to be in the position and mode of fixing in the tines or teeth, the direction of the bulls, and the manner in which the horses are attached in drawing the implements. It has been suggested by the author of *The Gentleman Farmer*, that no one harrow, whatever its construction may be, can be suitable for every sort of soil, or can act with equal effect on such grounds as are rough and smooth, or firm and loose: they must be adapted to the nature of the land, and the particular purposes the operator has in view. It is sufficiently evident, that in the lighter sorts of land, a small light harrow, with short tines or teeth, may be sufficient for the purpose; but in strong, heavy, and tenacious soils, or such as have been newly broken up from the state of old leys, or from a state of nature, such as commons, moors, and wastes, a harrow which has a much greater weight and longer teeth is to be preferred; and even where the land is rough and not easily reduced, as in the fallowing and reducing of strong clays, two harrows combined with each other may frequently be proper and necessary, in order to fully separate and break down the cloddy soil. And for these uses, it has also been found better, especially where the land is stiff, tenacious, and abounds much with the roots of weeds, that the harrows should not be too thickly set with teeth; as under such circumstances, where they have a number of teeth, they not only soon fill and choke up, which prevents them from working, but are confined too much to the surface, by which the soil is very imperfectly broken down and reduced into a state of powdery fineness.

2569. *The harrows most generally used* (fig. 321.) are of an oblong shape, each containing twenty prongs or tines, five or six inches long beneath the bulls or bars in which they are inserted. It is still common for every harrow to work separately; and though always two, and sometimes three, are placed together, each of them is drawn by its own horse. The great objection to this method is, that it is scarcely possible, especially upon rough ground, to prevent the harrows from starting out of their place, and riding on one another. To obviate this inconvenience, the exterior bulls of each are usually surmounted by a frame of wood, raised so high as to protect it from the irregular motions of its neighbor; but in many instances they are connected by chains or hinges, or cross-bars, which is a preferable plan.

Another objection which has been made to the common harrow is, that the ruts made by the tines are sometimes too near and sometimes too distant from one another; but this is probably not a great fault when the soil requires to be pulverised as well as

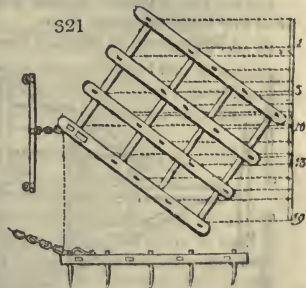

the seed covered, especially when they are permitted to move irregularly in a lateral direction. Where the soil is already fine, as it ought always to be before grass seeds are sown, lighter harrows are used, which are so constructed, that all the ruts are equidistant.

2570. *The angular-sided hinged harrow (fig. 322.)* is one of the best implements of the kind, as it both operates on the ground with great regularity, and is less liable to ride or be deranged in turning, than the common, or the rhomboidal harrow.

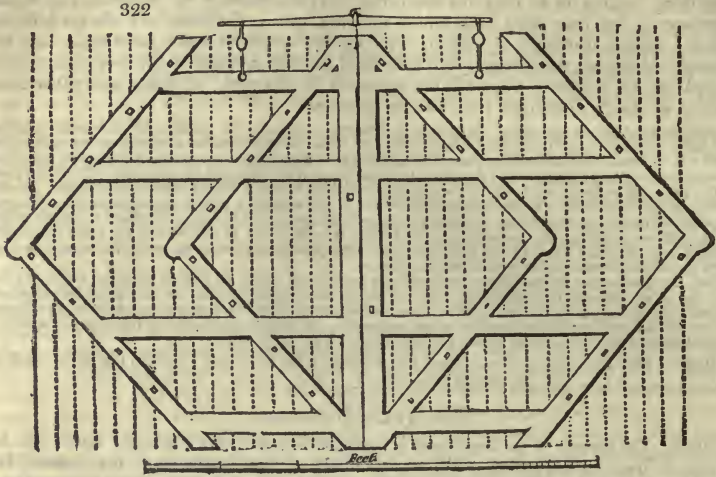

2571. *The improved Scotch or rhomboidal harrow (fig. 323.)*, consists of two harrows joined together; they are generally made heavy or light, according to the purpose for which they are intended, or the nature of the ground on which they are to be employed. Iron rods are fixed in two bulls of each harrow, having hasps and hooks; by this means the harrows are connected, and the same distance from one another is preserved, as that between any two bulls in the harrow; and though the teeth are not placed equidistant from each other in the bulls of this, as well as in the bulls of the old harrow, nevertheless, the teeth in this harrow move in lines equidistant from each other, so that not any two teeth of these harrows move in the same track; and, as they divide the surface into equal small parts, the ground must be pulverised in a more expeditious and superior manner, than can be done by the old common harrow. This advantage is obtained by forming the harrow not square, but of a rhomboidal shape, the angle of which must be according to the number of the teeth.

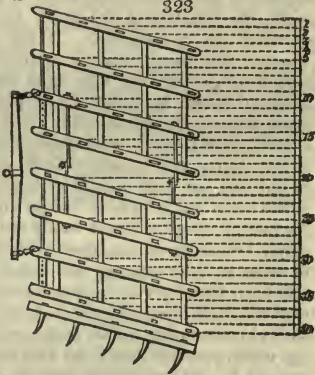

2572. *The grass seed harrow* is only a lighter construction of the rhomboidal harrow or of any other approved form.

2573. *The brake or levelling harrow (fig. 324.)* is a valuable implement. It consists

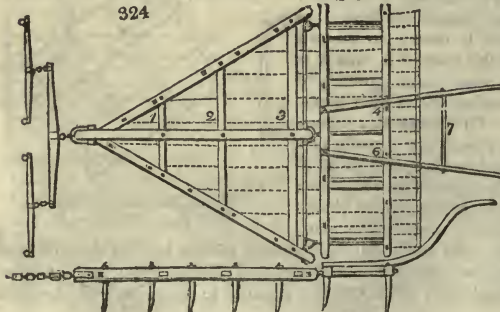

of two frames, the one triangular and the other oblong. By means of the handles, the oblong part of this brake can either be raised up or depressed; so that when the ground is cut in small pieces by the teeth of the triangular harrow, then the oblong harrow following, its teeth being pressed down into the high parts, carry or drag part of the soil off from the heights; and when they are raised up by the handles, leave that soil

in the hollow or low parts. By this means, the ground is brought nearly to one plain

surface, whether that surface be horizontal or sloping. Sometimes it may be found necessary to place a greater number of teeth in the oblong part of the brake, so as they may be nearer to one another, and perform the operation more effectually. The teeth are made sharp or thin on the fore-edge, for cutting; broad and thick on the back, for strength; and tapering, from a little below the bulls to their joints.

2574. *Gray's seed-harrow for wet weather* (fig. 325.), promises to be useful in certain situations, as in a tenacious retentive soil and moist climate. The sowing of wheat under existing circumstances, is one of the most important branches of the corn farmer's labor. In some backward seasons, it is almost impossible to get wheat land harrowed according to the common method, especially land that has been reduced by summer-fallow, without subjecting it to poaching from the horses, which is not only unfavorable to the soil, but also occasions a great waste of seed. Hence it

often happens, that a less quantity of grain is got sown than was intended, or requisite for the supply of the market. The beam (a) to which the harrows are attached, admits of being made shorter or longer as the width of the ridge requires; the shafts have freedom to turn round either to the right hand or to the left, and the teeth of the harrows are placed square in the bulls, so that they can be drawn from either end at pleasure. The wheels (fig. 326.) may be from three to four feet in diameter if made on purpose; but for the professional farmer it will be sufficient to borrow a pair from a one horse cart.

2575. *Harrows of various kinds* are now very frequently made of iron, which, when the material is not too dear, is a desirable circumstance on account of their durability.

2576. *The bush harrow* (fig. 327.) is used for harrowing grass lands, and covering grass, or clover seeds; small rigid branches of spray are interwoven in a frame, consisting of three or more cross-bars, fixed into two end-pieces in such a manner as to be very

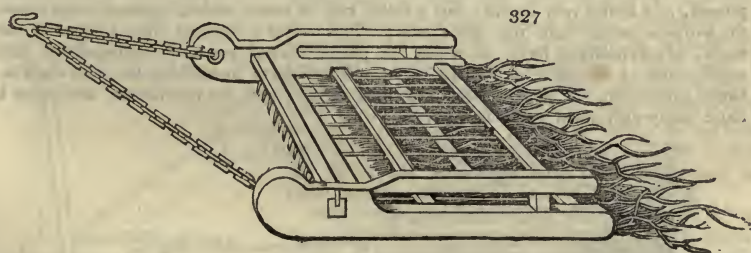

rough and brushy underneath. To the extremities of the frame before are sometimes attached two wheels, about twelve inches in diameter, upon which it moves; sometimes, however, wheels are not employed, but the whole rough surface is applied to, and dragged on, the ground.

2577. *The only essential implement of the harrow kind* is the rhomboidal (fig. 323.).

#### SECT. IV. Of Rollers.

2578. *The roller* is constructed of wood, stone, or cast-iron, according to convenience or the purposes for which it is to be used. For tillage lands, the roller is used to break the lumps of earth, and in some cases to press in and firm the ground about newly-sown seed; on grass lands it is used to compress and smooth the surface, and render it better adapted for mowing. It has been matter of dispute whether rollers with large or small diameters have the advantage in point of effect upon the land. It is probable that there may be inconveniencies in both extremes. The roller should not, however, be so small as to require much loading, as by such means much time and labor is lost. A

late writer advises, that in "constructing heavy rollers, the workmen should be careful that they have not too great a diameter, whatever the material be of which they are formed, as the pressure is diminished where the implement is of very large size, by its resting on too much surface at once, except an addition of weight in proportion be made. By having the roller made small, when loaded to the same weight, a much greater effect will be produced, and a considerable saving of expense be made in the construction of the implement." And he recommends that "all the larger sorts of rollers should have double shafts, in order that they may be drawn by two horses abreast; and such as are employed for arable lands should have a scraper attached to them. This addition, he thinks, saves much time, and prevents the driver the trouble of constantly scraping the machine, especially in wet seasons, and clayey tenacious lands. Strong frames are also necessary for rollers, so that proper weights may be put upon them; and open boxes or carts (*fig. 328.*) placed upon them may sometimes be requisite, in order to contain any additional weight that may be thought proper, as well as to receive stones or other matters that may be picked up from the ground. Pieces of wood or stone, as heavy as a man can lift, are the most suitable substances for loading these implements with, where they have not the advantage of boxes" for the purpose of containing such weighty substances.

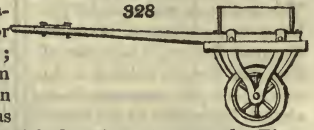

2579. *The common roller* is employed for the common purposes of reducing soils, and for rolling wheat or other crops in the spring, and grass-seeds. It is generally about five or six feet long, and from fifteen to thirty inches in diameter; but those employed for flattening one-bout ridges, in order to prepare them for drilling turnips upon, are commonly shorter and of much less diameter.

2580. *The parted cast-iron roller* was invented to remedy the inconvenience experienced in the use of the common implement in turning at the ends of ridges or other places, where, from their not moving upon their axis, but being drawn along the surface of the ground, they are liable to bear it up, and make depressions before the cylinder comes again into the direct line of draught; and at the same time they are not brought round without great exertion in the teams. The cylinder, in two pieces (*fig. 329.*), obviates this inconvenience by enabling the two parts to turn round on their own axis, the one forward, and the other in a retrograde direction.

2581. *The spiky or compound roller* is occasionally employed in working fallows, or preparing stiff bean land for wheat. In stiff clay-ground, when ploughed dry, or which has been much trod upon, the furrow-slice will rise in large lumps, or hard clods, which the harrow cannot break so as to cover the seed in a proper manner. In this state of the ground, the rollers commonly used have little effect in breaking these hard clods. Indeed, the seed is often buried in the ground, by the clods being pressed down upon it by the weight of the roller. To remedy this, the spike-roller has been employed, and found very useful; but a roller can be made, which, perhaps, may answer the purpose better than the spike one. This roller is formed from a piece of hard wood, of a cylindrical form, on which are placed several rows of sharp-pointed darts, made either of forged iron, or cast metal. These darts, by striking the hard clods in a sloping direction, cut or split them into small pieces; and, by this means, they must be more easily pulverised by the harrow.

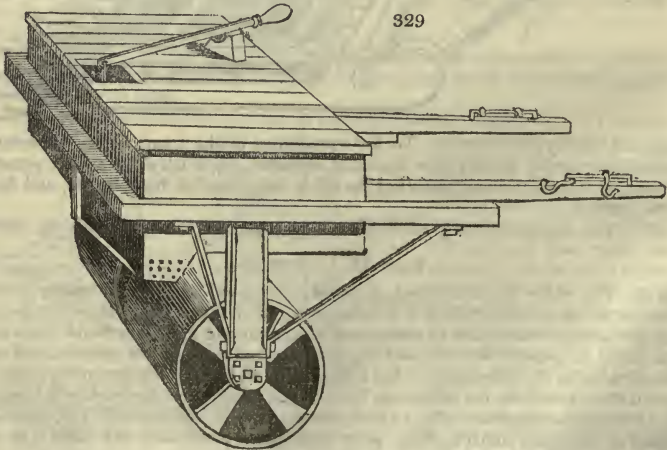

2582. *The roller and water box* (fig. 329.) is sometimes used for watering spring crops, or clovers with liquid manure, previously rolling them. It has the advantage of a more perfect machine, in the holes being easily cleaned when choaked up with the thickened water. Such a machine can seldom require the roller attached.

2583. *The furrow-roller* (fig. 330.), is contrived for the purpose of rolling the furrows in steep hilly situations, and other places where the common sort cannot be employed.

2584. *The Norfolk drill-roller*, and the ridge and furrow concave or scalloped roller attached to certain turnip-drills, have already been depicted (2553. and 2556.).

2585. *The pressing plough* is a term erroneously applied to a machine of the roller kind, which has been already described (2515.).

2586. *The only essential roller* for general purposes, is the parted cast-iron roller, with a scraper, and box over.

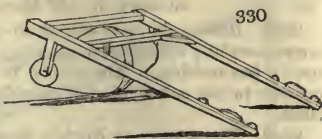

SECT. V. *Of Machines for laying Land even, and other occasional or anomalous Tillage Machines.*

2587. *Various machines* for agricultural purposes are occasionally brought into notice by amateur cultivators, and some even by the professional farmer. It is, indeed, the privilege and the characteristic of wealth and intelligence, to procure to be made whatever particular circumstances may require, in every department of the mechanical agents of culture. We shall only notice a few, and that chiefly for the purpose of shewing the resources of the present age.

2588. *Of machines for laying land level* two may be noticed: in the first and best (fig. 331.), the horses are harnessed to a pole (a), which is joined to an axle having a pair of low wheels (b, c). Into this axletree are mortised two long side-pieces (d), terminating in handles (e, e). Somewhat inclined to these long or upper side pieces, shorter lower ones are joined by cross-pieces, and connected by strong side-boards. The machine has no bottom; its back part (f), is strongly attached to an axle (fig. 332 g), and to the bottom of this the scraper part (h) is firmly screwed. The front ends of the slide irons (fig. 331 m), turning up, pass easily through mortises in the upper side-pieces (d), where, by means of pins, the inclination of the slide irons, and of the back board, can be adjusted within narrow limits, according to the nature of the soil to be levelled, and the mass of earth previously loosened by ploughing. This earth the back board is intended to collect and force before it, until the machine arrives at the place where it is intended to be deposited. Here, by lifting up the hinder part of the machine by its handles (e, e), the contents are left on the ground, and the machine proceeds to a fresh hillock. (*Supp. Encyc. Brit. i. 25.*)

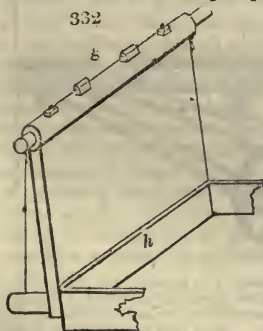
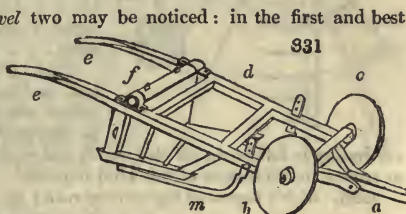

2589. *The Flemish levelling machine* (fig. 333.) may be considered as a shovel, on a large scale, to be drawn by a pair of horses; it collects earth at the pleasure of the holder, who contrives to make the horses turn over the shovel and empty the contents by merely letting go the handle (a), and recovering it by means of a cord (b), when emptied, as already described (501.).



2590. *The levelling harrow* (2573.) is adequate for all ordinary purposes.

SECT. VI. *Of Machines for reaping and gathering the Crop.*

2591. *The horse machines of harvest and haytime are chiefly the threshing machine, the hay todder, and horse rakes.*

SUBSECT. 1. *(Of Horse Rakes and Haymaking Machines.*

2592. *Raking machines are not in very general use; but where corn is mown, they are successfully employed in drawing together the scattered stalks, and are also of great use in hay-making. The saving in both cases consists in the substitution of animal for manual labor.*

2593. *The common or Norfolk horse-rake (fig. 334.) is employed for barley and oat crops, and also for hay. One man, and a horse driven by means of a line or rein, are capable of clearing from twenty to thirty acres, in a moderate day's work; the grain being deposited in regular rows or lines across the field, by simply lifting up the tool and dropping it from the teeth, without the horse being stopped.*

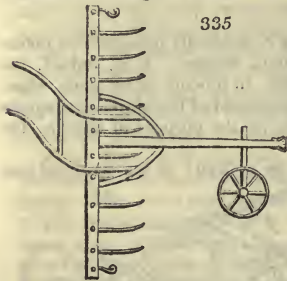
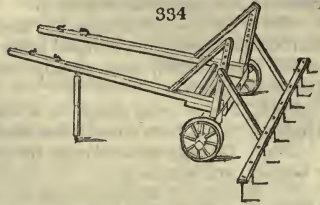

2594. *The horse stubble rake (fig. 335.) is a large heavy kind of horse rake, having strong iron teeth, fourteen or fifteen inches in length, placed at five or six inches from each other, and a beam four inches square, and eight or ten feet in length. In drawing it two horses are sometimes made use of, by which it is capable of clearing a considerable quantity of stubble in a short time. In general, however, it is much better economy to cut the stubble as a part of the straw.*

2595. *The couch-grass rake differs little from the last, and is employed in following very foul lands, to collect the couch-grass or other root weeds. It may be observed, however, that where a good system of cultivation is followed, no root weeds will ever obtain such an ascendancy in the soil, as to render an implement of this kind requisite.*

2596. *Weir's improved hay or corn rake (fig. 336.) is adjusted by wheels, and is readily*

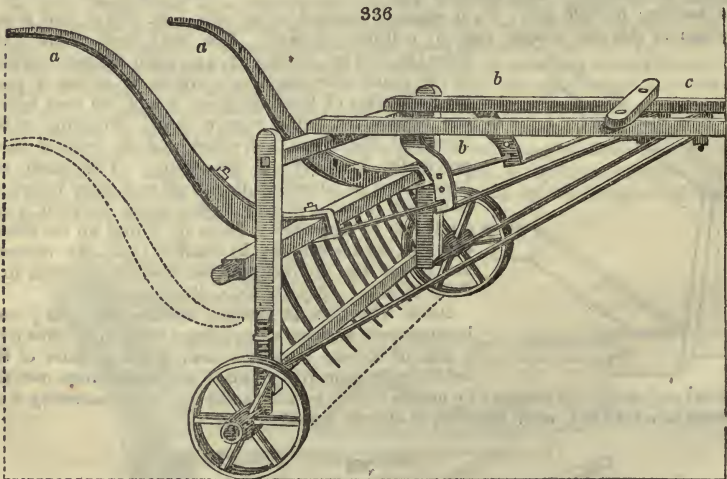

put in and out of gear, by means of the handles (*a, a*) and bent iron stays (*b, b*). It is drawn by one horse in shafts (*c*), and is a very effective implement.

2597. *The hay tedding machine (fig. 337.), invented about 1800, by Salmon of Woburn, has been found a very useful implement, especially in making natural or meadow hay, which requires to be so much more frequently turned, and thinner spread out, than hay from clover and rye grass. It consists of an axle and pair of wheels, the axle forming the shaft of an open cylindrical frame, formed by arms proceeding from it, and from the extremities of which bars are fixed, set with iron prongs, pointing outwards, and about six inches long and curved. There is a crank by which this cylinder of prongs is*



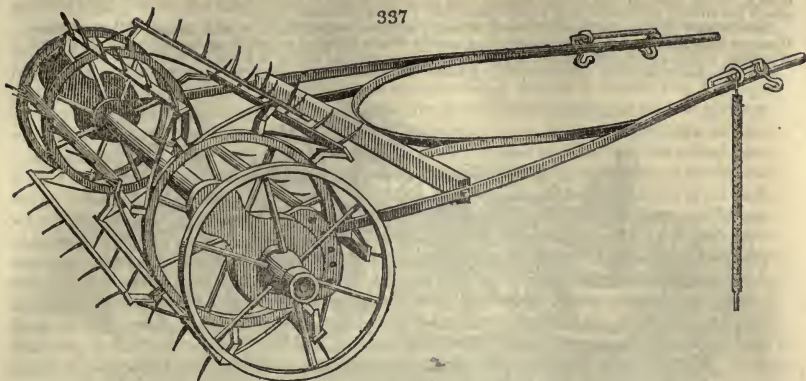

raised from the ground, when the machine is going to, and returning from, the field; or when it is not wanted to operate. It is drawn by one horse, and, on the whole, answers as a tedding machine perfectly. In the neighborhood of London, where meadow hay is so extensively made, it is found to produce a great saving of labor, and is now coming into very general use.

2598. *The hay sloop or sweep* (fig. 338.) is an implement for drawing or sweeping accumulations of hay to the cart or rick, or to any larger accumulations. Sometimes a rope is merely put round the heap, especially if it has been a few days in the cock, or piled up; but the most general hay-sloop consists of two curved pieces of wood, six or eight feet long, joined by upright pieces, so as to form something like the back of a chair. To the four corners of this, ropes are attached, which meet in the hook of a one horse whipple tree (a).

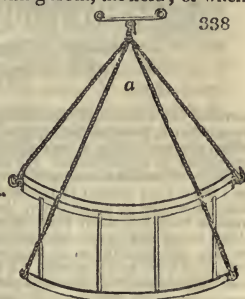

SUBJECT. 2. *Reaping Machines.*

2599. *Though reaping machines*, as we have seen (133.), are as old as the time of the Romans, one of an effective description is yet a desideratum in agriculture. The high price of manual labor, however, will probably in time call forth such a reaping machine as may be employed in all ordinary situations, and this is, perhaps, all that can be desired or expected. Corn laid down, or twisted and matted by wind and rain, or growing among trees, or on very irregular surfaces, or steep sides of hills, will probably ever require to be reaped by hand. But independently of the high price of labor, despatch, as an able author observes (*Supp. Encyc. Brit.* i. 118), is a matter of great importance in such a climate as that of Britain. In reaping corn at the precise period of its maturity, the advantages of despatch are incalculable, especially in those districts where the difficulty of procuring hands, even at enormous wages, aggravates the danger from the instability of the season. It cannot, therefore, fail to be interesting; and we hope it may be also useful, to record some of the more remarkable attempts that have been made towards an invention so eminently calculated to forward this most important operation.

2600. *The first attempt at a reaping machine*, so far as we have learned, was made by Boyce, who obtained a patent for a reaping machine fifteen or twenty years ago. This machine was placed in a two-wheeled carriage, somewhat resembling a common cart, but the wheels were fixed upon the axle, so that it revolved along with them. A cog-wheel, within the carriage, turned a smaller one at the upper end of an inclined axis, and at the lower end of this was a larger wheel, which gave a rapid motion to a pinion fixed upon a vertical axis, in the fore part of the carriage, and rather on one side, so that it went before one of the wheels of the carriage. The vertical spindle descended to within a few inches of the surface of the ground, and had there a number of scythes fixed upon it horizontally. This machine, when wheeled along, would, by the rapid revolution of its scythes, cut down a portion of the corn growing upon the ground over which it passed, but having no provision for gathering up the corn in parcels and laying it in proper heaps, it was wholly unsuited to the purpose.

2601. *An improvement on this attempt* was made by Plucknet, an agricultural implement maker, of London, some years afterwards. The principal alteration he made, was in substituting for the scythes a circular steel plate, made very sharp at the edge, and notched at the upper side like a sickle. This plate acted in the same manner as a very fine toothed saw, and was found to cut the corn much better than the scythes of the original machine.

2602. *A machine, invented by Gladstones, of Castle Douglas*, in the stewartry of Kirkcubright, operated upon nearly the same principles with Plucknet's; but Gladstone's made its work much better by introducing a circular table, with strong wooden teeth notched below all around, which was fixed immediately over the cutter and parallel to it. The use of these teeth was to collect the corn and retain it till it was operated on by the circular cutter. The corn, when cut, was received upon this table, and, when a sufficient quantity was collected, taken away by a rake or sweeper, and laid upon the ground beneath the machine, in separate parcels. To this machine was added a small circular wheel of wood, covered with

emery, which, being always kept in contact with the great cutter at the back part, or opposite side to that where the cutting was performed, kept it constantly ground to a sharp edge.

2603. *Salmon of Woburn made the next attempt*, and his invention, it is said, promised better than those we have mentioned. It was constructed upon a totally different principle, as it cut the corn by means of shears; and it was provided with a very complete apparatus for laying it down in parcels as it was cut.

2604. *The latest machine* (fig. 339.), and by much the most ingenious and promising of which we have

339

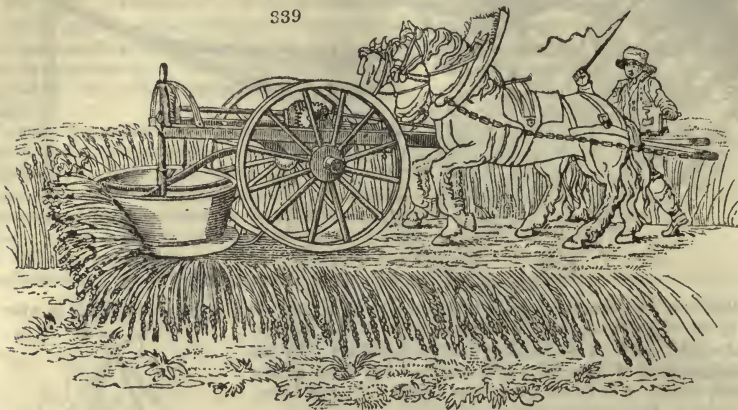

received any account, is that constructed by Smith, of the Deanston Cotton Works, Perthshire. Smith's perseverance, his successive improvements, and ingenious yet simple contrivances for remedying defects, afford strong grounds to hope that he will ultimately succeed in rendering his machine a most valuable acquisition to agriculturists. He made the first trial of his machine upon a small scale, during the harvest of 1811. It was then wrought by two men. In 1812 he constructed one upon a larger scale, to be wrought by a horse; but though he cut down several acres of oats and barley with considerable ease, it was found that, when met by an acclivity, the horse could not move the machine with proper effect. In 1813, he made a more successful attempt, with an improved machine, worked by one man and two horses; and (1814) it was still farther improved by an additional apparatus, tending to regulate the application of the cutter, when working on an uneven surface. This ingenious machine has been again tried, in September 1815, and with much success. A Scotch acre ( $1\frac{1}{2}$  acre English) of beans was cut down with ease in an hour and a quarter. The trials made with it on wheat, though not extensive, were satisfactory; and in reaping oats, the corn was laid down in the most regular manner. The cutter of this machine is circular, and operates horizontally; it is appended to a drum connected with the fore-part of the machine, its blade projecting some inches beyond the periphery of the lower end of the drum; and the machine is so constructed as to communicate, in moving forward, a rapid rotatory motion to this drum and cutter, by which the stalks are cut, and, falling upon the drum, are carried round and thrown off in regular rows. This most ingenious piece of machinery will cut about an English acre per hour, during which time the cutter requires to be four times sharpened with a common scythe stone. The expense of this machine is estimated at from thirty to thirty-five pounds. If properly managed, it may last for many years; only requiring a new cutter every two or three years, a repair which cannot cost much.

2605. *A machine for reaping the heads or seed pods of clover* (fig. 340.), where the second growth of that crop is left to stand for seed, has been used in some parts of Norfolk and Suffolk. It consists of a comb, the teeth of which are lance-shaped, very sharp and set close. This comb is affixed horizontally to the fore-part of the bottom of an open box or barrow, which is drawn by one horse and guided by a man, who empties the barrow in regular lines across the field by means of an implement (a), which serves also to clean the teeth.

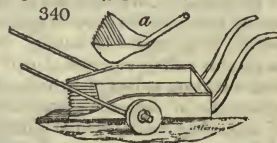

2606. *A machine for mowing clover hay* has frequently been attempted, but not yet perfected. One by Plucknet, of the Blackfriars Road, London, succeeded tolerably, but never came into use: it consisted of circular knives put into rapid motion, and the cut stalks guided to one side by a revolving cradle, like that attached to corn and scythes (2405.). It never came into use.

#### SECT. VII. *Machines of Deportation.*

2607. *The carriage or conveyance machines of agriculture* are chiefly carts and wag-gons, and their several varieties.

##### SUBSECT. 1. *Carts.*

2608. *Carts*, like other implements, vary in their forms and modes of construction, according to the nature and situation of the roads, and many other local circumstances; but, for the purposes of farming, those of the single-horse kind are in general the most advantageous and useful. The advantages of single-horse carts, Lord R. Seymour observes (*Ann. Ag. xxvii.*), are universally admitted, wherever they have been attentively compared with carriages of any other description. A horse, when he acts singly, will do half as much more work as when he acts in conjunction with another; that is to say, that two horses will, separately, do as much work as three conjunctively: this arises, in

the first place, from the single horse being so near the load he draws; and, in the next place, from the point or line of draught being so much below his breast, it being usual to make the wheels of single-horse carts low. A horse harnessed singly, has nothing but his load to contend with; whereas, when he draws in conjunction with another, he is generally embarrassed by some difference of rate, the horse behind or before him moving quicker or slower than himself; he is likewise frequently inconvenienced by the greater or lesser height of his neighbor: these considerations give a decided advantage to the single-horse cart. The very great ease with which a low cart is filled may be added; as a man may load it, with the help of a long-handled shovel or fork, by means of his hands only; whereas, in order to fill a higher cart, not only the man's back, but his arms and whole person must be exerted. To the use of single horses in draught there can be no objection, unless it be the supposed necessity of additional drivers created by it: the fact however is, that it has no such effect; for horses once in the habit of going singly, will follow each other as uniformly and as steadily as they do when harnessed together; and accordingly we see, on the most frequented roads in Ireland, men conducting three, four, or five, single-horse carts each, without any inconvenience to the passengers: such, likewise, is the case where lime and coal are generally carried upon pack-horses. In some of the northern counties of Britain also, one man manages two or three, and sometimes more, one-horse carts.

2609. *Carts drawn by one or two horses*, says a writer, whose authority is unquestionable (*Supp. Encyc. Brit.*), are the only farm carriages of some of the best cultivated counties, and no other are ever used in Scotland. Their load depends upon the strength of the horses, and nature of the roads; but in every case, it is asserted that a given number of horses will draw a great deal more, according to some one-third more, in single-horse carts than in waggons. Two-horse carts are still the most common among farmers in Scotland; but those drawn by one horse, two of which are always driven by one man, are unquestionably preferable for most purposes. The carriers of the west of Scotland usually load from a ton, to a ton and a half, on a single-horse cart, and no where does it carry less than 12 cwt. if the roads are tolerable.

2610. *Wheels*, such as are broad, with conical or convex rims, are common in England; in Scotland the wheels are generally narrow, though broader ones are beginning to be introduced. Those used for the common, or two-horse carts, are usually about  $4\frac{1}{2}$  feet high, and mounted on iron axles. The advantages of broad cylindrical wheels have been illustrated with much force and ingenuity in several late publications. (*Communications to the Board of Agriculture*, vol. ii. and vol. vii. part i.)

2611. *The Scotch one-horse cart* in general use in husbandry is what is called a *close coup cart*, and is either used without or with a frame (fig. 341.) for corn, straw or hay. On drawing out an iron pin, the fore part of the body rises up from the shafts, while the other end sinks and allows the load, whether of dung, earth, or stores in the close cart or of hay, or sheaves of corn on the cart and frame, to fall to the ground.

341

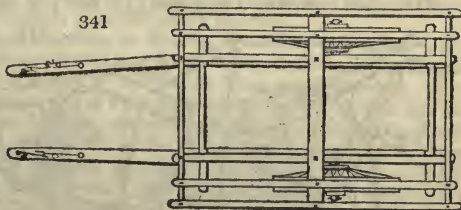

2612. *The Scotch two-horse cart* differs little from the one-horse cart, excepting in being larger. To prove the inferiority of double to single horse carts, Gray observes, "that whatever greater part of the load is placed before the centre of gravity, which is always in the axle, must rest constantly on the horse that is in the shafts. In going down hill, this burden must be considerably increased, especially if the load be high above the centre of the axle, or the descent steep; and the additional burden upon the shaft-horse is always in proportion to these two causes united. But there is another disadvantage; for unless the line of the draught of the foremost horse be exactly in the line, from the hook of his collar to the centre of the axle, (which is hardly possible), he will perpetually be pulling down the hindmost horse, or, in other words, will be giving him more weight to carry. For, as the traces of the foremost horse are generally fixed upon the shafts, this throws his line of draught at a considerable angle above the centre of the axle; from which it is evident, that although the road be ever so level, yet in every double or two-horse cart, the foremost horse must either not draw at all, or must bring additional weight upon the horse in the shafts, which weight will always be in proportion to the force with which the trace-horse draws, and the largeness of the angle, which the line of his draught makes with the line from the hook of his collar to the centre of the axle. Besides, unless the driver be more careful than ordinary, and keep the trace horse to his duty, the other one has not only this great weight to carry, but also the whole load to draw. The angle is increased considerably, when the trace horse is of a lower size

than the one in the shafts, which may frequently happen; and by this means, a still greater burden is laid upon the back of the horse employed in the shafts.

2613. *Improved two-horse carts* (fig. 342.). It may be suggested to those who are

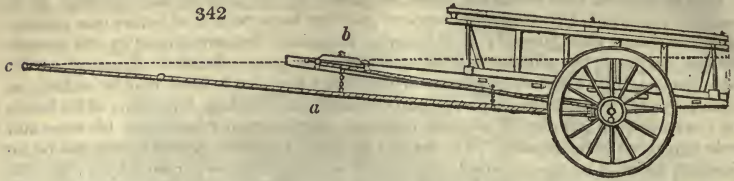

fond of employing two-horse carts, that in order to adjust the traces of the fore horse with as little injury as possible to the one behind, and by this means make both their powers coincide, two iron frames are fixed into the axle, in each of which is placed a sheeve or whorle. Upon these sheeves, pass a rope or chain (a). In the outside of each shaft is fixed a long iron staple; and on each staple, is placed an iron slider (b), having liberty to shift either forward or backward; the chain from the collar of the shaft horse is hooked into the eye of the slider; and the chain or rope, by which the foremost horse draws, passing from his collar (c), round on the sheeve at the axle, is hooked into the other eye of the slider. By this means, the two horses are so connected, that if the one shall relax, immediately the exertion of the other horse presses the collar hard upon his shoulders, so that he must either exert himself, or be pulled backwards. Thus the exertion of the two horses are united, so as to form one power, applied to the cart, in place of two powers, working generally against one another, which must be the case in the common way of attaching two horses to a cart. But, by this way of yoking, the shaft horse receives no additional burden from the exertion of the trace horse, as they both draw from one point, which is the centre of the axle, to the hooks of their respective collars, by which their powers must nearly coincide. If this coincidence does not take place, it is evident that the two horses will, to a certain degree, be pulling against one another, which must be extremely distressing to each in his turn, especially to the one in the shafts.

2614. *The corn cart* has a longer body than the close cart, and the sides and ends are open and support two rails along each. It is made to fit the axle and wheels of the close cart, and is chiefly used in haytime and harvest, when it is supposed to admit of laying on a larger load of sheaves or hay than the cart and frame.

2615. *Lord Somerville's drag-cart* (fig. 343.) is constructed with a contrivance for

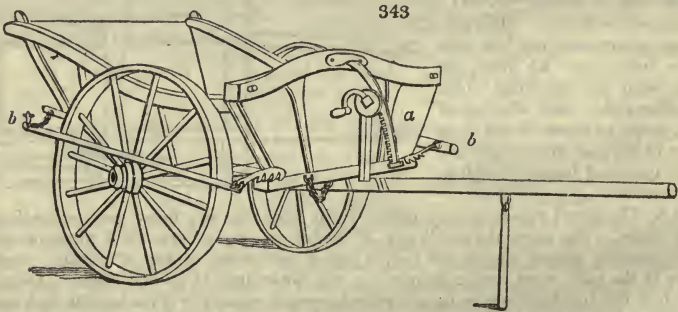

checking or regulating the rapidity of its motion in going down hills or other declivities. The method for adjusting the position of the centre of gravity of the load, and to prevent its pressing too much on the cattle in going down hill, is by a toothed rack, screwed to the front of the cart, and worked by a pinion and handle (a) immediately connected with the pole. By means of this pinion and rack, the front of the carriage is elevated more or less, in proportion to the declivity of the hill, by which means the weight of the load is made to bear more on the axis, and less on the necks of the oxen. A friction drag (b) is made to press more or less on the side of the wheel, according to the steepness of the descent; the one end of it is connected with the tail of the cart by a small chain, and the other end to the front, by means of a toothed rack, which catches on a staple in the front of the cart, by which the friction-bar may be made to press on the side of the wheel, more or less, at the discretion of the driver: the notches or teeth in this rack, it is observed, should be as close to each other as circumstances will permit.

2616. *The advantages of the friction-drag*, and other contrivances, are said to be, 1st. The method, which is equally simple and expeditious, of adjusting the centre of gravity of the load, so as to have a proper

bearing on the horses or cattle, in going down hill. 2dly, The method of applying friction to the side of the wheel, to regulate the motion of the carriage in going down hill (instead of locking the wheels), the advantages of which method appear to be as follow : namely, first, the pressure and degree of friction may, with great expedition, be adjusted to the steepness of the declivity, so that the carriage will neither press forward, nor require much exertion to make it follow the cattle ; secondly, the friction is so applied to the wheel, that a given pressure will have twice the effect in retarding the progress that it would have if immediately applied to the body of the carriage, or to the axis ; and by applying the friction on both sides of the wheel, the risk of heating and destroying the friction-bar is much less than if the same degree of friction was applied in one place. 3dly, This apparatus is so conveniently placed, that it can be instantly applied or adjusted, without stopping the carriage, or exposing the driver to the same danger as in locking a wheel. And, 4thly, This contrivance will assume yet a greater importance when applied to both the hind wheels of waggons, by which means the resistance may always be proportioned to the steepness of the descent, the tearing up of the road prevented, the unnecessary exertion of the cattle in drawing the locked carriage down hill avoided, the danger to which the driver is sometimes exposed in locking the wagon-wheel totally evaded, and the time now lost in locking and unlocking the wheel saved to the proprietor.

2617. *The improved quarry cart* has a bend in its iron axle, which brings it within fourteen inches of the ground, although moving on wheels more than five feet high. The ease with which it is drawn, loaded and unloaded, is superior to the common cart in the proportion of seven to three.

2618. *The three wheel cart* is a low machine on wheels about two feet in diameter, the third wheel placed in the middle before, and generally of smaller size than the two others. It is used for conveying earth or gravel to short distances, as in canal and road making, and for these purposes it is a most valuable machine, and in very general use.

#### SUBJECT. 2. *Waggons.*

2619. *Waggons* constructed in different forms, and of various dimensions, are made use of in different districts of the kingdom ; and mostly without much attention to the nature of the roads, or the articles which are to be conveyed by them ; being, in general, heavy, clumsy, and inconvenient. *Waggons* require much more power in the draught than carts, and are far from being so handy and convenient, which is certainly an objection to them, though they carry a much greater load. There can be no doubt that more work may be done in any particular time, with the same number of horses, by carts than by waggons, in the general run of husbandry business, especially where the distance is small between loading and unloading. *Waggons* may perhaps be the most proper sort of conveyances for different sorts of heavy loads to a considerable distance ; but for home business, especially harvest and other field work, which requires to be speedily performed, carts seem decidedly preferable.

2620. *Waggons*, though they may possess some advantages over carts in long journeys, and when fully loaded, the editor of *The Farmer's Magazine* observes, are now admitted to be much less convenient for the general purposes of a farm, and particularly on occasions which require great dispatch, as in harvesting the crop.

2621. *The Gloucestershire waggon*, according to Marshal, is the best in England. By means of a crooked side-rail, bending archwise over the hind-wheel, the bodies or frames of them are kept low, without the diameter of the wheels being much lessened. The bodies are likewise made wide in proportion to their shallowness, and the wheels run six inches wider than those of most other waggons, whereby advantages in carrying top-loads are evidently obtained. Rudge, in his survey of the above district, says, that in many districts, waggons are the principal carriages employed in getting in the hay, and are either full-bedded, or with three-quarter beds. The former have the advantage of a greater length of bed, but are not so convenient for turning ; the latter, though diminished in size, have the convenience of locking the fore-wheels, and turning in almost as narrow a compass as a chaise, in consequence of the bed being hollowed out on each side near the middle, to admit the exterior part, or felloes of the fore-wheels. Both waggons are capable of carrying nearly the same weight, though the former, being deeper in the bed, is somewhat better adapted for the carriage of heavy articles, such as bags of corn, &c. For the purpose of harvesting, or carrying hay and straw, their length and width are increased by light ladders before and behind, and of similar contrivances called "rathes," the whole length of the sides. The ladders are put on and taken off at pleasure, in both kinds, but the side additions are generally fixed, except in the strait-headed, which are in use on the western side of the Severn ; in these they are made removeable, so as to leave the bed quite naked.

2622. *The Berkshire waggon* (fig. 344.) is constructed on a simple and convenient principle, not having the usual height or weight of other waggons, while it possesses sufficient strength, and is easy in the draught. An improvement suggested is that of

leaving the space sufficiently deep in the body or bed for the fore-wheels to lock round in the shortest curve, as in the present manner of its construction, a great deal of time



is lost turning at the ends of the swarths, in carrying hay, and on many other occasions. In this way, the inconvenience may be removed without doing the smallest injury to the symmetry or strength of the carriage.

2623. *The Norfolk cart and waggon* is formed by adding a pair of fore-wheels and shafts to a common cart, connected by a pole from axle to axle. It is said to be light, cheap, and convenient, and capable of carrying nearly as much hay or straw as the Berkshire waggon.

2624. *Rood's patent waggon* (fig. 345.) is a contrivance whereby the same carriage

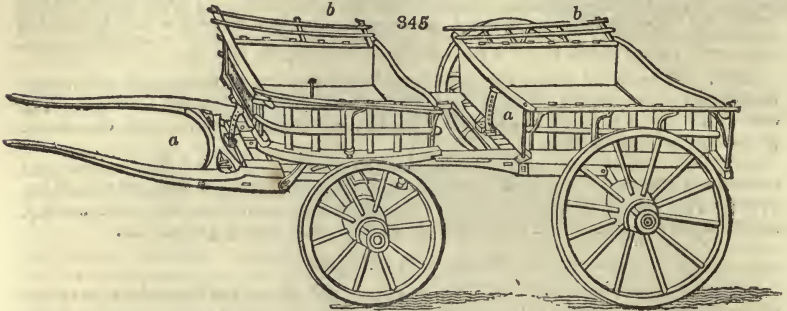

may, in a few minutes, be changed by the driver into two complete tip-carts of the common dimensions, and applicable to all the uses of carts in general, or into one waggon, so complete, that a narrow inspection is necessary to distinguish it from a common waggon. The carts have a contrivance (*a, a*) to render them more safe and easy to the horse in going down a hill, and have moveable side-ladders, (*b, b,*) which will be found of great use in carrying corn, bark, &c. It may be constructed with perfect facility by the wheel-wrights of any county; its shape and particular dimensions can be suited to the wishes of the owner, or to the local fashion of his neighborhood. The result of considerable experience and inquiries, enables its inventor to state, that it may, in any county, be completed for about five pounds more than the cost of two common carts. It must, however, be admitted to be somewhat more clumsy than a common waggon.

#### SECT. VIII. *Machines for threshing and otherwise preparing Corn for Market.*

2625. *Threshing and preparatory machines* include threshing and winnowing machines, and awn and smut machines. Threshing machines are common in every part of Scotland, on farms where the extent of tillage-land requires two or more ploughs; and they are every year spreading more and more in England and Ireland. They are worked by horses, water, wind, and, of late, by steam; and their powers and dimensions are adapted to the various sizes of farms. Water is by far the best power; but as a supply cannot be obtained in many situations, and as wind and steam require too much expense for most farms, horses are employed more generally than any other power. Where wind-mills are erected, it is found necessary to add such machinery as may allow them to be worked by horses occasionally in very calm weather; and the use of steam must be confined, for the most part, to the coal districts.

2626. *The operation of separating the grain from the straw* was long performed by the flail, to the manifest injury of both the farmer and the community; for though, in some cases, the work was tolerably well performed, yet in a greater majority of instances it was otherwise. A quantity, perhaps, equal to the seed over the county, was lost even in the best cases; but where the allowance to the thresher was either a proportion of the produce, known by the name of lot, generally a twenty-fifth part; or, when he was paid in money, at so much per boll, the temptation to do the work in a slovenly manner was so great, that a quantity, perhaps double of what was required for seed, was lost upon many farms; an evil that did not escape the notice of intelligent men, by several of whom attempts were made to construct machines that would do the work more perfectly; this, therefore, seems to have led to the construction and use of this valuable machine.

2627. *The first threshing-machine*, as before observed (771.), was invented by Menzies, brother to the then sheriff-depute of East Lothian; the machinery was driven by a water-wheel, which put in motion a number of flails of the same kind with those used in threshing by the hand. Trials made with these machines were so far satisfactory, that a great deal of work was done in a given time, but owing to the velocity required to do the work perfectly, they soon broke, and the invention fell into disgrace.

2628. *Another attempt*, some time in the year 1758, was made by a farmer in the parish of Dumblane, in Perthshire. His machine was constructed upon principles similar to the flax-mill, having an upright shaft with four arms inclosed in a cylinder, three and a half feet in height, and eight in diameter, within which the shaft and its arms were turned with considerable velocity by a water-wheel. The sheaves, being presented by the hand, were let down from the top upon the arms, by which the grain was beat out, and, together with the straw, descended through an opening in the floor, where they were separated by riddles and faners, also turned by the water-wheel.

2629. *A third attempt*, about twenty years after, was made by Elderton, near Alnwick, and Smart, at Wark, both nearly about the same time. Their machine was so constructed as to act by rubbing, in place of beating out the grain. The sheaves were carried between an indented drum, about six feet in diameter, and a number of rollers of the same description ranged round the drum, towards which they are pressed by springs, in such a way as to rub out the grain, when the drum was turned round. Upon trial,

this machine was also found ineffectual, as along with its doing very little work in a given time, it bruised the grain, and so materially hurt its appearance, as to lessen its value considerably in the market.

2630. *The machine in its then imperfect state*, was seen by the late Sir Francis Kinloch, Bart. of Gilmerton, a gentleman well acquainted with mechanics, and who had paid much attention to country affairs; it occurred to him that the machine might be rendered more perfect, by inclosing the drum in a fluted cover, and fixing on the outside of it four fluted pieces of wood, capable of being raised a little from the circumference by springs, in such a way as to press against the fluted cover, and to rub out the grain as the sheaves passed between them; but after repeated trials, it was found to bruise the grain nearly as much as the model from which it was copied. In that state it remained for some time, and was afterwards sent by Sir Francis to a very worthy and ingenious character, Meikle of Know Mill, in his neighborhood, a mill-wright by profession, who had for a considerable time employed his thoughts upon the same subject. After much consideration and several trials, it appeared to Meikle that the purpose of separating the grain from the straw might be accomplished upon a principle different from any that had hitherto been attempted, namely, by skutches acting upon the sheaves by their velocity, and beating out the grain, in place of pressing or rubbing it out; accordingly a model was constructed at Know Mill, in which the grain was beat out by the drum, to which it was presented through two plain feeding-rollers, which were afterwards altered for fluted ones. The first machine on a large scale, executed upon this principle, was done by a son of Meikle's, for Stein, of Kilbagie, in the year 1786, which, when finished, performed the work to the satisfaction of all parties, and established Meikle's principle of beating out the corn as superior to all others. This superiority it still maintains, and is likely ever to do so.

2631. *Many improvements have been made on these machines* since their introduction. One of the most useful of these, perhaps, is the method of delivering the straw, after it has been separated from the corn by the circular rake, to what is called a *travelling-shaker*, which carries it to the straw-barn. This shaker, which revolves like the endless web used in cotton and other machinery, is composed of small rods, placed so near as to prevent the straw from falling through, while any threshed corn that may not have been formerly separated, drops from it in its progress, instead of falling along with it, where it would be trodden down and lost.

2632. *Improved mode of yoking the horses*. It is well known that the work of horses in threshing-mills is unusually severe, if continued for any length of time; that they sometimes draw unequally; that they, as well as the machine itself, are much injured by sudden jerks and strains, which are almost unavoidable; and that, from this irregularity in the impelling power, it requires much care in the man who presents the corn to the rollers, to prevent bad thrashing. It is therefore highly desirable that the labor should be equalized among the horses, and the movements of the machine rendered as steady as possible. A method of yoking the horses in such a manner as compels each of them to take his proper share of the labor, has accordingly been lately introduced, and the necessary apparatus, which is neither complicated nor expensive, can be added to any machine worked by animal power. (*Farmer's Magazine*, vol. viii. p. 279. § 2638. and fig. 346.)

2633. *Winnowing machines added*. All well-constructed threshing-mills have one winnowing machine, which separates the chaff from the corn before it reaches the ground; and a second sometimes receives it from the first, and gives it out ready for market, or nearly so. If the height of the building does not admit of this last addition, a separate winnowing machine, when the mill is of great power, is driven by a belt from it. In either of these ways there is a considerable saving of manual labor.

2634. *Advantages of threshing machines*. With a powerful water-mill, the editor of *The Farmer's Magazine* observes, it cannot be doubted, that corn is threshed and dressed at no more expense than must be incurred for dressing alone, when threshed with the flail. Besides, the corn is more completely detached from the straw; and, by being threshed expeditiously, a good deal of it may be preserved in a bad season which would have spoiled in a stack. The great advantage of transferring forty or fifty quarters of grain in a few hours, and under the eye of the owner, from the yard to the granary or market, is of itself sufficient to recommend this invaluable machine, even though there were no saving of expense.

2635. *The specific advantages resulting from the use of the threshing machine*, are thus stated in *The Code of Agriculture*: 1. From the superiority of this mode, one-twentieth part more corn is gained from the same quantity of straw, than by the old fashioned method. 2. The work is done more expeditiously. 3. Pilfering is avoided. 4. The grain is less subject to injury. 5. Seed corn can be procured without difficulty from the new crops, for those to be sown. 6. The market may be supplied with grain more quickly in times of scarcity. 7. The straw, softened by the mill, is more useful for feeding cattle. 8. If a stack of corn be heated, it may be threshed in a day, and the grain, if kiln-dried, will be preserved, and rendered fit for use. 9. The threshing-mill lessens the injury from smutty grain, the balls of smut, not being broken, as when beaten by the flail; and, 10. By the same machine, the grain may be separated from the chaff and small seeds, as well as from the straw. Before the invention of threshing-mills, farm-servants and laborers endured much drudgery; the large corn farmer sustained much damage from bad thrashing; and had much trouble, vexation, and loss, from careless and wicked servants; but now, since the introduction of this valuable machine, all his difficulties, in these respects, are obviated.

2636. *The advantage that might be derived by the public, were threshing mills used in every case*, for separating corn from the straw, is thus estimated by Brown of Markle.

The number of acres producing grain in Great Britain, at	8,000,000	one-twentieth part of the produce, or in quarters, at	1,200,000	
The average produce in quarters, at 5 qrs. per acre, at	40,000,000		The value of that increased quantity at 40s. per quarter	L2,400,000
The increased quantity of grain produced by threshing-mills, instead of using the flail, at	1		The saving in the expense of labor, at 1s. per quarter	L1,200,000

2637. *A variety of threshing machines* have been made in England, both on the rubbing and beating, or scutching principle, and some combining both modes; but none have been found to answer the purpose of separating the grain from the straw so well as those of Meikle, which is the kind exclusively used in Scotland and the north of England.

2638. *Meikle's two horse threshing machine with the new invented yoking apparatus* (fig. 346.), is the smallest size of horse engine which is made. From the limbers, or hanging pieces (a), by which the cattle draw when working this machine, proceed the chains or ropes to which the horses are yoked, being united by an iron frame, placed upon a lever, having liberty to turn on a bolt; one end of each of two single ropes is fixed to this iron frame, and upon their other ends are fixed small blocks; in each of which is placed a running sheeve; and over these sheeves, pass double ropes or chains. One horse is yoked to these chains at the one arm, and the other at the other, so that the chains or ropes by which they draw, being connected by the blocks, and the sheeves having liberty to move either way, if one of the horses relax,

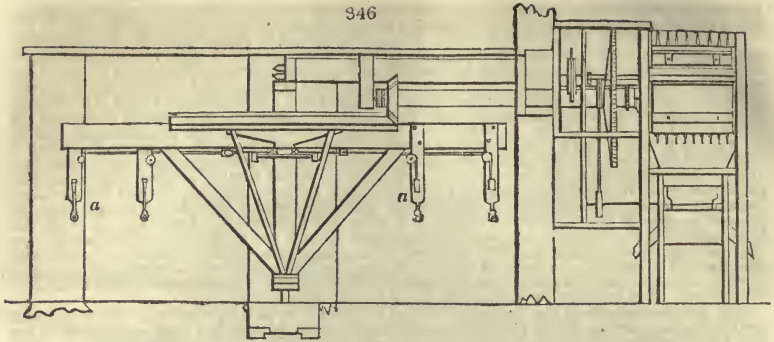

immediately the other presses the collar to his shoulders. For instance, if the horse yoked to the chains at one arm (*fig. 347 a.*) were to relax, then the one yoked at the other (*b*) would instantly take up his rope, and pull the collar hard to his shoulders, so that the lazy horse must either exert himself, or be drawn backward; until the hooks, to which he is yoked, rest on the limbers. Thus each horse spurs up his fellow, they being both connected by the ropes and sheeves; their exertions are united, so as to form one

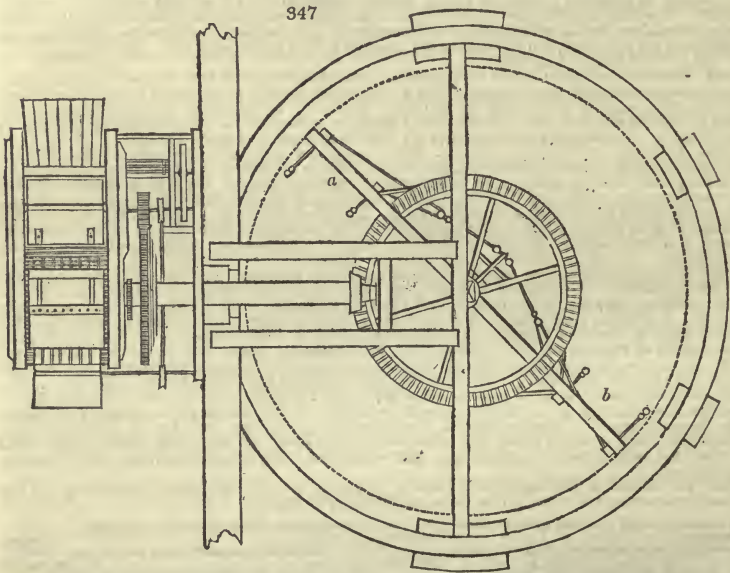

power applied to the machine, instead of two powers, independent of one another. By this means, the draught will always press the collars equally upon the horses' shoulders, and though they are working in a circle, yet the strains of the draught must press fair, or equal, on their shoulders, without twisting their body to either side. This advantage cannot be obtained in the common way of yoking horses in a threshing machine, unless the draught-chains on each side of the horse be made in exact proportion in length to the diameter of the circle in which he walks, or the chain next to the centre of the walk made a little shorter than the one farthest from it, which is often neglected; but in this way of yoking the horses, the strain of the draught will naturally press equal on his shoulders when pulling, which of course must be less severe on the animal when walking in a circle.

2639. *The advantages of this method of yoking horses to a threshing machine, which was invented by Walter Samuel, blacksmith at Niddry, in the county of Linlithgow, have been fully ascertained by experience, and acknowledged by the most intelligent farmers in Scotland. They are as follow:*



1st. The very great comparative ease obtained for the cattle, in this the heaviest part of their work. This, without doubt, is a real saving of labor; for it is no exaggeration to affirm, that five horses, yoked by this apparatus to a threshing machine, will perform with equal ease the labor of six horses, of equal strength and weight, yoked in the common way, each horse being independent of the rest.

2dly. A very great saving results in the tear and wear of the machine, from the regularity and uniformity of the movement. This will be acknowledged by any judge of the subject who witnesses the performance. The sudden jerks and strains that generally take place in the usual way, are found to be quite removed; the machinery moving with that kind of uniformity as if driven by water. In consequence of which, the work is better performed, and that in a very perceptible degree.

2640. *Meikle's water threshing machine* (fig. 348.), is the preferable engine when a supply of water can be obtained. The main axle or shaft (a), upon which is fixed the water-wheel (b),

has placed upon its circumference cast metal segments (c), the teeth of which turn the pinion which is fastened on the axle of the threshing drum; the platform, on which the unthreshed corn is spread, joins the feeding rollers, that conduct the corn forward to the threshers; next the threshing-drum is

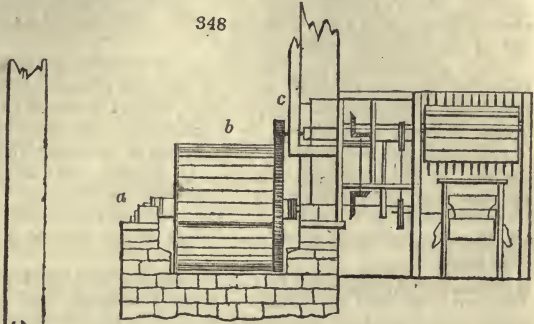

the straw-shaker, driven by a leathern belt, passing over a sheeve, fixed on an iron spindle, connected with the axle of the water-wheel, and the sheeve on the axle of the shaker.

2641. *Meikle's threshing machine to be driven by water or by four horses* (fig. 349.), is

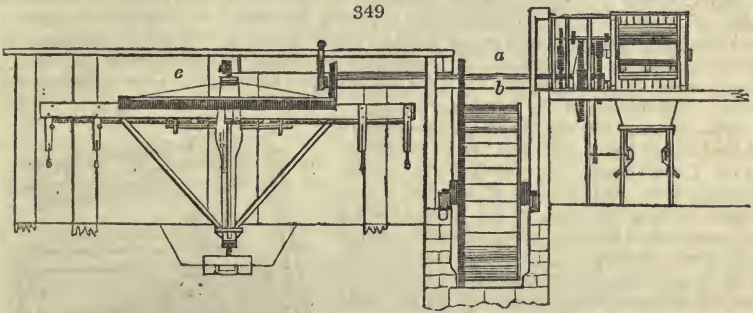

a powerful and convenient engine, as advantage may be taken of water when it is abundant, and in dry seasons horses can be applied. To this machine the improved apparatus for yoking the horses is appended, and by the simple operation of varying the positions of the pinions on the common shaft (a), which communicate with the water and horse wheel (b, c), threshing may be carried on without interruption, either with the water or the horses separately; or a small quantity of water may be applied to assist the horses at any time, when a sufficient supply of water cannot be obtained to impel the machine alone.

2642. *Meikle's threshing machine to be driven either by wind or six horses*, (Gray, Pl. XII.) is a powerful but costly erection. On large corn farms, however, it will answer to erect such machines; and there are frequent instances in Berwickshire and Northumberland, of farmers incurring that expense on the security of twenty-one years leases. The machinery of the wind power of this machine is fitted up with a small van to turn the large ones to face the wind, and with the machinery necessary to roll on or off the sails according as the wind increases or diminishes; by which means the naturally unsteady power of wind is rendered as regular as that of horses or water. The threshing part of this machine contains the usual apparatus, and also a complete set of fanners and screens for cleaning the corn. To the board upon which the unthreshed grain is spread, and introduced between the feeding rollers, succeeds the drum, with the threshers, or beaters, fixed upon the extremity of its arms; then the shaker, that receives the straw from the threshing drum, and conveys it to the second shaker, by which it is thrown down a sloping searce, either on the low floor, or upon a sparred rack, which moves on rollers, turned by the machine, and by this means is conveyed into the straw-shed, or else into the barn yard. One searce is placed below the

threshing-drum, while its circular motion throws out the straw at an opening, into the straw-shaker, which conveys it to the second shaker; at the same time, the chaff and grain pass down through a scarce, or sparr'd rack, into the hopper, which conveys it into the fanners, by which the corn is separated from the chaff, the clean grain running out at the opening, and the chaff, or any light refuse, blown out at the end by the rapid motion of the fans, which are driven by a band or rope, from a sheeve placed upon the axle of the threshing-drum, and passing over the sheeve, fixed upon the pivot of the fans.

2643. *Meikle's threshing machine to be impelled by steam* is the same arrangement of interior machinery with a steam engine outside of the barn connected by a shaft in the manner of the wind and water machines.

2644. *Portable threshing machines*, to be fixed in any barn, or in the open field, for threshing the crops of small farms, or for other purposes of convenience, are differently contrived. Excepting the hand machine, already described (2453.), all of them work by horses, and generally with one, or at most two. The most complete have a large frame of separating beams into which the gudgeons of the larger wheels work, and which retains the whole of the machinery in place. In general, there is no fanners; but sometimes a winnowing machine is driven by a rope from the threshing machinery. Such machines are considerably more expensive, in proportion to their power, than fixed machines; they are, therefore, not much used, and indeed might often be profitably substituted by the hand machine.

2645. *Weir's portable two horse power, threshing machine* is one of the best in England. The corn is threshed on Meikle's skutching principle, and is sometimes fed by fluted rollers, and sometimes introduced through a hopper directly over the drum, a mode which is found not to break the straw so much as the common mode.

2646. *Lester's portable threshing machine* received the straw without the intervention of rollers, and separated the corn entirely by rubbing. It was an ingenious, but very imperfect machine, and never came into use.

2647. *Forrest of Shifnal's portable threshing machines* have been employed in several parts of Warwickshire, Shropshire, and adjoining counties. It combines the rubbing and skutching methods, but does not perform either perfectly. Meikle's machines, in fact, can alone be depended on, for completely separating the grain from the straw; though some others may render the straw less ineligible for thatch, or for gratifying the present taste in litter of the London grooms.

2648. *The smut machine* (fig. 350.) is the invention of Hall late of Ewel, in Surrey, now of the Prairie in the United States. It resembles that used for dressing flour, and consists of a cylinder perforated with small holes, in the inside of which are a number of brushes, which are driven round with great rapidity. The wheat infected with smut is put into the cylinder, by a hopper (a), and the constant friction occasioned by the rapid motion of the brushes (b), effectually separates the smutty grain, which is driven out by the holes of the cylinder. Hall finds that it requires much more power to clean wheat by this machine, than to dress flour. A machine on this construction, might be a very useful appendage to every threshing machine, for the purpose of effectually cleaning all wheat intended for seed, or such wheat, meant for the market, as had a great proportion of smut in it. (*Stevenson's Surrey*, p. 141.)

2649. *To take the awns from barley* where a threshing machine is used, a notched spar lined on one side, with plate iron, and just the length of the rollers, is fixed by a screw bolt at each end to the inside of the cover of the drum, about the middle of it, so as the edge of the notched stick is about one-eighth of an inch from the arms of the drum as it goes round. Two minutes are sufficient to put it on, when its operation is wanted, which is, when putting through the barley the second time; and it is as easily taken off. It rubs off the awns completely.

#### SECT. IX. *Mechanical and other fixed Apparatus, for the Preparation of Food for Cattle, and grinding Manure.*

2650. *The principal food preparing contrivances*, are the steamer, boiler, roaster, breaker or bruiser, and grinder.

2651. *An apparatus for steaming food for cattle*, the editor of *The Farmer's Magazine* observes, should be considered a necessary appendage to every arable and dairy farm, of a moderate size. The advantage of preparing different sorts of roots, as well as even

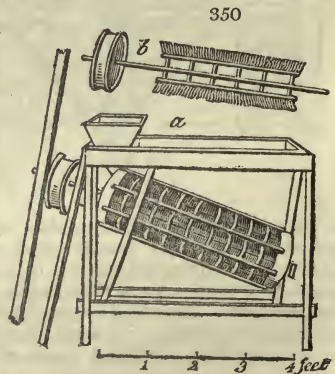

grain, chaff, and hay, by means of steaming apparatus, for the nourishment of cattle, begins now to be generally understood. It has been long known that many sorts of roots, and particularly the potatoe, become much more valuable by undergoing this sort of preparation. And it is equally well known that when thus prepared they have been employed alone as a substitute for hay, and with cut chaff both for hay and corn, in the feeding of horses, as well as other animals. To a farmer who keeps many horses or cattle, or even swine or poultry, the practice of boiling their food in steam is so great a saving, and an advantage, that it deserves the most particular attention. Though potatoes have often been given raw to both horses and cattle, they are found to be infinitely preferable when cooked by steam, as they are rendered thereby much drier, and more nutritive, and better than when boiled in water; this has been long since shown by the experiments of Wakefield, of Liverpool, who in order to ascertain it, fed some of his horses on steamed and some on raw potatoes, and soon found the horses on the steamed potatoes had greatly the advantage in every respect. Those on the steamed potatoes looked perfectly smooth and sleek, while the others were quite rough. Eccleston also found them useful instead of corn; and the extensive and accurate trials of Curwen, have placed the utility and advantage of them in this way beyond all dispute. Curwen has found that in their preparation in this way the waste of the potatoe is about one-eighteenth part, and that straw when given along with them answers equally well as hay, as the horses keep their condition and do their work equally well.

2652. *A steaming apparatus on a grand scale* has been erected at Workington, by Curwen, of which an accurate ground plan and section with a copious description, are given in *The Complete Farmer*. (Art. *Steaming Apparatus*.) Though very extensive, it is less perfect than some others which we shall describe.

2653. *An economical steaming and washing machine* has been described by Grey, in his *Implements of Husbandry, &c.* The parts of this machine are few and simple; the potatoes are washed and emptied into a large chest to drip; and when a sufficient quantity is washed, this chest, by a motion of the crane, empties itself into a steaming-box, placed almost immediately over the boiler; by which means a large quantity of potatoes or other materials are steamed at once. The chief advantage attending the use of this simple steaming apparatus, he says, consists in saving manual labor, lifting on and off the tubs for holding the potatoes, or other materials to be steamed; also the expense of erection and repairs of leaden or copper pipes, turn-cocks, &c. Its superiority over one with a number of steaming tubs, especially in a large operation, will be at once perceived by those who have paid attention to the subject. The steaming boiler may be made of any approved form, and of a size proportioned to the steaming-box, with a furnace of that construction which affords the greatest quantity of heat to the boiler, with the smallest waste of fuel. The steaming-box may be made either of cast metal plates, enclosed in a wooden frame, or of stout planks, well joined, and firmly fixed together. It has been found by experience, that a box, eight feet in length, five feet wide, and three feet deep, will serve for cooking, in the space of one hour, with the attendance of one person, a sufficient quantity of potatoes to feed fifty ordinary horses, allowing each horse thirty-two pounds weight per day: The boiler and steaming-box, however, ought to be made of a size in proportion to the number of cattle to be fed, or the quantity of materials to be steamed; both boiler and steaming-box may be made of any form and proportion that will best answer the intended purpose, with the least expense.

2654. *A steaming machine on a simple and economical plan* (fig. 351.), consists of a boiler and wooden chest or box placed over or near it. The box may be of any size, and so placed as to be supplied and emptied by wheel or hand barrows in the easiest manner, either by the end or top, or both, being made to open. If the box is made 8 feet by 5, and 3 deep, it will hold as many potatoes as will feed 50 cows for 24 hours, and these may be steamed in an hour. (*F. Mag.* vol. xviii. p. 74.)

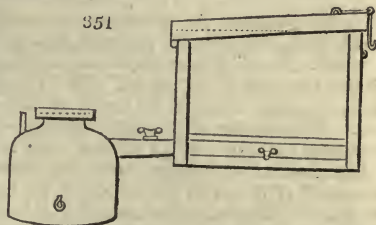

2655. *Boilers or boiling machines* are only had recourse to in the case of very small establishments. By means of fixed boilers, or boilers suspended by cranes, on the Lodi dairy principles (270), roots may be boiled, and chaff, weak corn, and other barn refuse, rendered more palatable and nutritive to cattle. Hay tea also may be made, which is a salutary and nutritive drink for horses or cattle when unwell, or for calving cows. Food for swine and poultry may also be prepared in this way: or water boiled and salted to half prepare chaff and culmiferous messes for animals.

2656. *A baking or roasting oven* has been recommended for preparing the potatoe by Pierrepont (*Comm. Board of Ag.* vol. iv.), which he states to be attended with superior advantages; but as, independently of other considerations, the use of such an oven must

be limited to potatoes, a steaming machine, which will prepare any sort of food, is undoubtedly preferable for general purposes. Many speculative plans of this sort, however ingenious, chiefly deserve notice as beacons to be avoided, or to prevent their being invented and described a second time.

### CHAP. III.

#### *Edifices in use in Agriculture.*

2657. *A variety of buildings are necessary for carrying on the business of field culture; the nature and construction of which must obviously be different, according to the kind of farm for which they are intended.* Suitable buildings, the editor of *The Farmer's Magazine* observes, are scarcely less necessary to the husbandman than implements and machinery; and might, without much impropriety, be classed along with them, and considered as one great stationary machine, operating more or less on every branch of labor and produce. There is nothing which marks more decidedly the state of agriculture in any district, than the plan and execution of these buildings.

2658. *In erecting a farmery, the first thing that deserves notice is its situation, both in regard to the other parts of the farm, and the convenience of the buildings themselves.* In general, it must be of importance on arable farms, that the buildings should be set down at nearly an equal distance from the extremities; or so situate, that the access from all the different fields should be easy, and the distance from those most remote, no greater than the size of the farm renders unavoidable. The advantages of such a position in saving labor, are too obvious to require illustration; and yet this matter is not nearly so much attended to as its importance deserves. In some cases, however, it is advisable to depart from this general rule; of which one of the most obvious is, where the command of water for a threshing-mill, and other purposes, can be better secured in another quarter of the farm.

2659. *The form most generally approved for a set of offices, is that of a square, or rather a rectangular parallelogram; the houses being arranged on the north, east, and west sides, and the south side fenced by a stone wall, to which low buildings, for calves, pigs, poultry, &c. are sometimes attached.* The space thus inclosed is usually allotted to young cattle: these have access to the sheds on one or two sides, and are kept separate according to their size or age, by one or more partition-walls. The farmer's dwelling-house stands at a short distance from the offices, and frequently commands a view of the inside of the square; and cottages for servants and laborers are placed on some convenient spot, not far from the other buildings.

2660. *The different buildings required for the occupation of land are chiefly those devoted to live stock, as the stable, cow-house, cattle sheds, &c.; those used as repositories or for conducting operations, as the cart-shed, barn, &c.; and human habitations or cottages and farm-houses.* After noticing the separate construction of these edifices, we shall exemplify their combination in different descriptions of farmeries.

#### SECT. I. *Buildings for Live Stock.*

2661. *Buildings for agricultural live stock are the stable, cow-house, cattle houses and cattle sheds, sheep houses, pig-styes, poultry houses, rabbitry, pigeonry, and bee-house.*

2662. *The stable is an important building in most farmeries; it is in general placed in the west side of the square, with its doors and windows opening to the east.* Nothing conduces more to the health of horses than the having a good and wholesome air. The situation of the stable should always be on a firm, dry, and hard ground, that in winter the horse may go out and come in clean; and where possible, be built somewhat on an ascent, that the urine and other liquid matters may be easily conveyed away by means of drains for the purpose. As there is no animal that delights more in cleanliness than the horse, or that more dislikes bad smells, care should be taken that there be no hen-roost, hog-styes, or necessary houses near the place where the stable is to be built. The swallowing of feathers, which is very apt to happen, when hen-roosts are near, often proves injurious to horses. The walls of a stable ought to be of brick rather than stone, and should be made of a moderate thickness, two bricks or a brick and a half at least, or the walls may be built hollow, not only for economy, but for the sake of warmth in the winter, and to keep out the heat in the summer. The windows should be proportioned in number to the extent, and made on the east or north side of the building, that the north wind may be let in to cool the stables in the summer, and the rising sun all the year round, especially in winter. They should either be sashed or have large casements for the sake of letting in air enough; and there should always be close wooden shutters,

turning on bolts, that the light may be shut out at pleasure. Many pave the whole stable with stone, but that part which the horse is to lie on is often boarded with oak planks, which should be laid as even as possible, and cross-wise rather than length-wise; and there should be several holes bored through them to receive the urine and carry it off underneath the floor by gutters into one common receptacle. The ground behind should be raised to a level with the planks, and be paved with small pebbles. There are mostly two rings placed on each side of the manger, or stall, for the reins of the horse's halter to run through, and a logger is to be fixed to the ends of these, sufficient to poise them perpendicularly, but not so heavy as to tire the horse, or to hinder him from eating; the best place for him to eat his corn in, is a drawer or locker, which need not be large, so that it may be taken out at pleasure to clean it, by which means the common dirtiness of a fixed manger may be avoided. Many people are against having a rack in their stables; they give the horse his hay in a trough bin, formed of boards with an open bottom.

2663. *A lofty stable* is recommended by White (*Treatise on Veter. Med.* p. 1.), fifteen or twenty but never less than twelve feet high, with an opening in the ceiling for ventilation. The floor he prefers is brick or limestone, inclining not more from the manger to the gutter than an inch in a yard. Some litter, he says, should always be allowed for a horse to stale upon, which should be swept away as often as is necessary. This, with a pail or two of water, thrown upon the floor, and swept off while the horse is at exercise, will keep the stable perfectly clean, and free from offensive smells.

2664. *The depth of a stable* should never be less than twenty feet, nor the height less than twelve. The width of a stall should not be less than six feet clear. But when there is sufficient room, it is a much better plan to allow each horse a space of ten or twelve feet, where he may be loose and exercise himself a little. This will be an effectual means of avoiding swollen heels, and a great relief to horses that are worked hard. With respect to the rack and manger, White prefers the former on the ground rising three feet high, eighteen inches deep from front to back, and four feet long. The manger, eighteen inches deep, eighteen inches from front to back, and five feet in length. The rack he prefers being closed in front, though some farmers prefer it open, alleging that horses when lying down will thus be enabled to eat if they choose. A close-fronted rack, however, is better adapted for saving hay. The back part of the rack should be an inclined plane made of wood; should be gradually sloped towards the front; and should terminate about two feet down. Such a rack will hold more hay than ever ought to be put before one horse. The advantages of this rack are numerous: in the first place, the hay is easily put into it, and renders a hay-loft over the stable unnecessary; which ought to be an inducement to the builder to make the stable as lofty as it ought to be, and render the ventilation unnecessary. All the hay that is put into this manger will be eaten, but in the common rack it is well known that a large portion of the hay is often pulled down upon the litter, and trodden upon, whereby a considerable quantity is often wasted. It prevents the hay seeds or dust from falling upon the horse, or into his eyes; and what is of considerable importance, though seldom attended to, there will be an inducement to the horse-keeper to give the horse hay in small quantities at a time, and frequently, from the little trouble which attends putting it into the rack. The saving in hay that may be effected by the use of this rack is so apparent, that it need not be dwelt upon. A great saving also may be made in oats by so fastening the horse's head during the time of feeding that he cannot throw any of them out of the manger. This kind of rack and manger, from being boarded up in front, will effectually prevent the litter from being kept constantly under the horse's head and eyes, by which he is compelled to breathe the vapors which arise from it. It will also prevent him from getting his head under the manger, as sometimes happens, by which means, not unfrequently, the poll evil is produced. The length of the halter should be only four feet from the head stall to the ring through which it passes: this will admit of his lying down with ease, and that is all which is required. The ring should be placed close to that side where the manger is, and not in the centre of the stall. The side of the stall should be sufficiently high and deep to prevent horses from biting and kicking each other. When the common rack and manger are preferred, the rack staves should be perpendicular, and brought nearly down to the manger, and this may easily be done without the necessity of a hay-loft, and the manger may be made deep and wide as described.

2665. *The window of the stable* should be at the south-east end, and the door at the opposite end. The window should be as high as the ceiling will admit of, and in size proportioned to that of the stable. In one of twelve feet high, it need not come down more than four feet, and it will then be eight feet from the ground, and out of the way of being broken. The frame of the window should be moveable upon a pivot in the centre, and opened by means of a cord running over a pulley in the ceiling, and fastened by means of another cord. With a window of this kind, in a stable of three or four horses, no other ventilation will be required: a person never need be solicitous about finding openings for the air to enter, where there is sufficient room above, and means for it to escape. A stable thus constructed will be found conducive to the health and comfort of horses, and will afford an inducement to the horse-keeper to attend to every little circumstance which may contribute to cleanliness. He will not allow the smallest bit of dung to remain swept up at one end of the stable, as it commonly is. The pails should be kept outside, and not standing about the stable, as they commonly are. If it is necessary to take off the chill from water, it is much better, and more easily done, by the addition of a little hot water, than by suffering it to stand in the stable; and while the horses are at exercise, the litter should be all turned out to dry, and the brick floor well washed or swept out. A little fresh straw may then be placed for the horses to stale upon. Litter thus dried during the day will serve again as well as fresh straw for the bottom of the bed, and be perfectly free from smell. The litter necessary to be kept under a horse that he may stale with comfort, and without splashing himself, is not considerable, and may be changed once a day. A great saving may be made in litter by turning it out, and drying it as described; and if a shed were built adjoining a stable, it might be done at all times, and might serve also to exercise and clean a horse in wet weather.

2666. *Neither dogs, fowls, nor goats, should ever be permitted to enter a stable; and dung should be kept at a distance from it.* A good contrivance in cleaning horses, is, to have two straps, one on each side the stall, about one yard from the head of it. By these the horse may be fastened during the time he is cleaned, by which he will be effectually prevented from biting the manger or the horse-keeper; and being kept back in the stall, the man will be better able to clean the front of his fore-legs, chest, and neck, and be able to move round him. This is better than strapping him to the rack.

2667. *Farm stables in Scotland*, the editor of *The Farmer's Magazine* observes, "are constructed in such a manner, that all the horses stand in a line with their heads towards the same side-wall, instead of standing in two lines, fronting opposite walls, as for-

merly. Those lately erected are at least sixteen feet wide within walls, and sometimes eighteen, and the width of each stall upon the length of the stable is commonly five feet. To save a little room, stalls of nine feet are sometimes made to hold two horses, and, in that case, the manger and the width of the stall are divided into equal parts by what is called a half trevice, or a partition about half the depth of that which separates one stall from another. By this contrivance, each horse indeed eats his food by himself; but the expense of single stalls is more than compensated by the greater ease, security, and comfort of the horses. The trevices or partitions which divide the stalls, are of deals two inches thick, and about five feet high; but, at the heads of the horses, the partition rises to the height of seven feet (fig. 352 a), and the length of the stall is usually from seven to eight feet. In many cases the end stall has a door or frame of boards to fit in between it and the back wall (b), in order to enclose food of any kind, a sick horse, a foal, or mare and foal, &c.

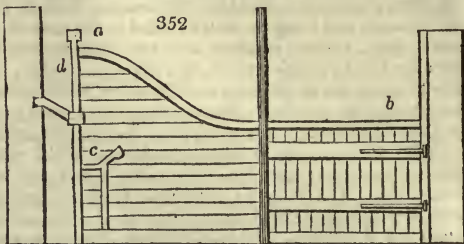

2668. *The manger (c)* is generally continued the whole length of the stable. It is about nine inches deep, twelve inches wide at the top, and nine at the bottom, all inside measure, and is placed about two feet four inches from the ground. Staples or rings are fixed on the breast of the manger, to which the horses are tied.

2669. *The rack* for holding their hay or straw, is also commonly continued the whole length of the stable. It is formed of upright spars (d), connected by cross rails at each end, and from two to two and a half feet in height. The rack is placed on the wall, about one foot and a half above the manger, the bottom almost close to the wall, and the top projecting outwards, but the best plan is to place it upright (c, d, a). The spars are sometimes made round, and sunk into the cross-rails, and sometimes square. In a few stables lately built, the round spars turn on a pivot, which facilitates the horse's access to the hay, without requiring the interstices to be so wide, as to permit him to draw it out in too large quantities.

2670. *Immediately above the racks* is an opening in the hay-loft, through which the racks are filled. When it is thought necessary, this may be closed by boards moving on hinges.

2671. *The racks in some of the best stables* occupy one of the angles between the wall and trevices, and form the quadrant of a circle. The spars are perpendicular, and wider placed than in the hanging racks. The hay-seed falls into a box below, instead of being dropped on the ground, or incommoding the eyes and ears of the horses.

2672. *Behind the horses,* and about nine feet from the front wall is a gutter, having a gentle declivity to the straw yard or urine pit. Allowing about a foot for this, there will remain a width of eight feet to the back wall, if the stable be eighteen feet wide; a part of which, close to the wall, is occupied with corn-chests and places for harness.

2673. *With a view to save both the hay and the seed,* it is an advantage to have the hay-stacks so near the stable as to admit of the hay being thrown at once upon the loft. In some stables there is no loft, and the hay is stored in a separate apartment.

2674. *The stable floor* is, for the most part, paved with undressed stones; but in some instances, the space between the gutter to the back, is laid with flags of freestone.

2675. *Horse-hammels,* or small sheds, with yards to each, have been used as stables in a few instances, and with great success in Berwickshire. Each shed holds two horses, with a niche for their harness: to each shed there is an open straw-yard, of small size, with a water trough, and a gate large enough to admit a cart to take out the dung. John Herriot, of Ladykirk, has long used these buildings for his horses with great success. He has lost none by death for a number of years, and they seldom have colds or any other disease. His horses lie in these open hammels in winter; and it is remarked, that in frosty weather, when snow is falling, and lying on the ground, the animals do not go under cover, but prefer to lie out, with their backs and sides covered with snow. It is well known, that if a horse is kept out in winter, he will have no grease, nor swelled legs, and perhaps few other diseases. These hammels seem to have all these advantages, at the same time that they protect the animal from damp, and prevent his back from being kept wet by heavy or long continued rains. Every farmer who keeps a large stock of horses, occasionally loses one by inflammation, brought on by coughs and colds; but the horses of the farmer alluded to, become aged, and he has not had occasion to purchase a young horse for several years. (*Husb. of Scot.* i. 26.)

2676. *Cattle-sheds* are used either for lodging milch cows, or for feeding cattle for the butcher. The principal requisites in buildings of this description are, that they be capable of being well aired; that they are so constructed as to require the least possible labor in feeding the cattle, and clearing away the dung; that the stalls be so formed as to keep the cattle as dry and clean as possible, with sufficient drains to carry away, and reservoirs to collect the urine and dung. There are three ways in which the cattle are placed; first, in a row towards one of the side walls; second, in two rows, either fronting each other, with a passage between, or with their heads towards both side walls; and, third, across, or upon the width of the house, in successive rows, with intervening passages for feeding and removing the dung. In the first place, it is usual to have openings in the walls, through which they are supplied with turnips, otherwise they must

necessarily be served from behind, with much inconvenience, both to the cattle-feeder and the cattle themselves. The plan that is most approved, and now becoming general when new buildings are erected, is to fix the stakes to which the cattle are tied about two and a half or three feet from the wall, which allows the cattle-man, without going among them, to fill their trough successively from his wheelbarrow or basket, with much ease and expedition. It is also a considerable improvement to keep the cattle separate, by partitions between every two. This will, in a great measure, prevent accidents, and secure the quiet animals from being injured by the vicious; for in these double stalls, each may be tied up to a stake placed near the partition, so as to be at some distance from his neighbor; and it is easy to lodge together such as are alike in size and in temper. The width of such stalls should not be less than  $7\frac{1}{2}$  feet, and the depth must be regulated by the size of the cattle.

2677. *Cattle hammels* (fig. 353). The practice of feeding cattle in small sheds and straw-yards, or what is called *hammels* in Berwickshire, deserves to be noticed with approbation, when saving of expense is not a paramount object. Two cattle are usually kept together, and go loose, in which way they are thought by some to thrive better than when tied to a stake, and, at the same time, feed more at their ease than when a number are kept together, as in the common straw-yards. All that is necessary is, to run partition-walls across the sheds and yards of the farmers; or if these are allotted to rearing stock, one side of the square, separated by a cart-way from the straw-yards, may be appropriated to these hammels. In the usual management of a row of cattle hammels in Berwickshire, there is one hammel (*a, b*) at one end used as a temporary repository for roots and straw for the cattle; then each hammel consists of the open yard (*d, a*), and the covered part (*c*): the entrance door, of which there is only one to each hammel, is in the wall of the yard (*f*), and on each side of it are two troughs (*e, e*) for food, and a crib for hay, straw, cut clover, or other herbage in summer.

2678. *Calf-pens or calf-stages*, are common additions to cow-houses, where the feeding of calves for the butcher is an object of pursuit. The principal thing to be observed in the construction of calf-pens is, the laying of the floor, which should be made of laths or spars about two inches broad, laid at the distance of an inch from each other, upon joists, so as to make the floor about ten or twelve inches from the ground, as the situation will admit (fig. 354.) This not only keeps them quite dry, by allowing all the moisture to pass immediately away, but has the advantage of admitting fresh air below the bedding, and thereby preventing that unwholesome disagreeable smell, too often found among calves; for it is to be understood, that this place below the floor (*a*) should frequently be cleaned, as well as the floor itself, whenever it becomes wet or dirty; but it is not right to allow the litter to increase to a great thickness, otherwise the moisture will not so easily pass through. Calf-pens are, however, too often made without this sparr'd floor, and the fresh litter always laid on the old, till the calves are removed, which is a slovenly practice, and not by any means to be recommended. Stalls, or divisions, are too often neglected in calf-pens. Partitions, about three feet high, of thin deal nailed on small posts, might be so contrived as to be moveable at pleasure, to increase or diminish the stall, if necessary, according to the age and size of the calf. If it be thought unnecessary to make the partitions moveable, there might be a small round trough, in a circular frame, fixed in the corner of each pen, for holding the milk, and a door in the next adjoining corner. A small slight rack for holding a little hay, placed at the upper part of the pen, might also be useful. The troughs should be round, that the calves may not hurt themselves upon them, which they might probably do on the angles if they were square. The advantages of this kind of calf-pens are, that the

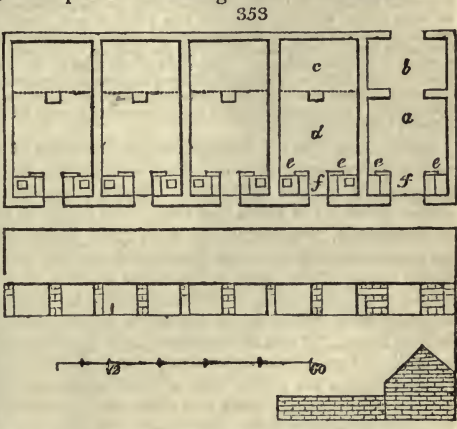

2678. *Calf-pens or calf-stages*, are common additions to cow-houses, where the feeding of calves for the butcher is an object of pursuit. The principal thing to be observed in the construction of calf-pens is, the laying of the floor, which should be made of laths or spars about two inches broad, laid at the distance of an inch from each other, upon joists, so as to make the floor about ten or twelve inches from the ground, as the situation will admit (fig. 354.) This not only keeps them quite dry, by allowing all the moisture to pass immediately away, but has the advantage of admitting fresh air below the bedding, and thereby preventing that unwholesome disagreeable smell, too often found among calves; for it is to be understood, that this place below the floor (*a*) should frequently be cleaned, as well as the floor itself, whenever it becomes wet or dirty; but it is not right to allow the litter to increase to a great thickness, otherwise the moisture will not so easily pass through. Calf-pens are, however, too often made without this sparr'd floor, and the fresh litter always laid on the old, till the calves are removed, which is a slovenly practice, and not by any means to be recommended. Stalls, or divisions, are too often neglected in calf-pens. Partitions, about three feet high, of thin deal nailed on small posts, might be so contrived as to be moveable at pleasure, to increase or diminish the stall, if necessary, according to the age and size of the calf. If it be thought unnecessary to make the partitions moveable, there might be a small round trough, in a circular frame, fixed in the corner of each pen, for holding the milk, and a door in the next adjoining corner. A small slight rack for holding a little hay, placed at the upper part of the pen, might also be useful. The troughs should be round, that the calves may not hurt themselves upon them, which they might probably do on the angles if they were square. The advantages of this kind of calf-pens are, that the

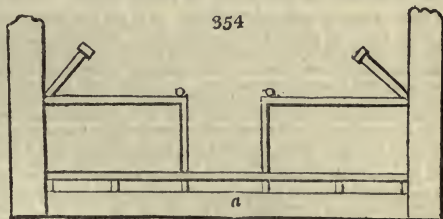

becomes wet or dirty; but it is not right to allow the litter to increase to a great thickness, otherwise the moisture will not so easily pass through. Calf-pens are, however, too often made without this sparr'd floor, and the fresh litter always laid on the old, till the calves are removed, which is a slovenly practice, and not by any means to be recommended. Stalls, or divisions, are too often neglected in calf-pens. Partitions, about three feet high, of thin deal nailed on small posts, might be so contrived as to be moveable at pleasure, to increase or diminish the stall, if necessary, according to the age and size of the calf. If it be thought unnecessary to make the partitions moveable, there might be a small round trough, in a circular frame, fixed in the corner of each pen, for holding the milk, and a door in the next adjoining corner. A small slight rack for holding a little hay, placed at the upper part of the pen, might also be useful. The troughs should be round, that the calves may not hurt themselves upon them, which they might probably do on the angles if they were square. The advantages of this kind of calf-pens are, that the

calves are all kept separate in a small compass, and cannot hurt each other, as the stronger ones sometimes do the weaker, when confined promiscuously, and their food may be much more easily and equally distributed.

2679. *The calf-pens in Gloucestershire*, Marshal observes, are of an admirable construction; extremely simple, yet singularly well adapted to the object. Young calves, fattening calves more especially, require to be kept narrowly confined: quietness is, in a degree, essential to their thriving. A loose pen, or a long halter, gives freedom to their natural fears, and a loose to their playfulness. Cleanliness, and a due degree of warmth, are likewise requisite in the right management of calves. A pen which holds seven, or occasionally eight calves, is of the following description:—The house or roomstead, in which it is placed, measures twelve feet by eight: four feet of its width are occupied by the stage, and one foot by a trough placed on its front; leaving three feet as a gangway, into the middle of which the door opens. The floor of the stage is formed of laths, about two inches square, lying lengthways of the stage, and one inch asunder. The front fence is of staves, an inch and a half diameter, 9 inches from middle to middle, and 3 feet high: entered at the bottom into the front bearer of the floor (from which cross-joists pass into the back wall), and steadied at the top by a rail; which, as well as the bottom piece, is entered at each end into the end wall. The holes in the upper rail are wide enough to permit the staves to be lifted up and taken out, to give admission to the calves; one of which is fastened to every second stave, by means of two rings of iron joined by a swivel; one ring playing upon the stave, the other receiving a broad leathern collar, buckled round the neck of the calf. The trough is for barley-meal, chalk, &c. and to rest the pails on. Two calves drink out of one pail, putting their heads through between the staves. The height of the floor of the stage from the floor of the room, is about one foot. It is thought to be wrong to hang it higher, lest, by the wind drawing under it, the calves should be too cold in severe weather: this, however, might be easily prevented by litter, or long strawy dung thrust beneath it. It is observable, that these stages are fit only for calves which are fed with the pail, not for calves which suck the cow.

2680. *Hog-styes* for the breeding or fattening of swine, are mostly built in a simple manner, requiring only warm dry places for the swine to lie in, with small areas before, and troughs to hold their food. They are generally constructed with shed-roofs, and seldom above six or seven feet wide, with height in proportion. In order that they may be convenient, they should be at no great distance from the house; and the less they are connected with the other farm-buildings the better. In some cases, it might be of utility to have them connected with the scullery, in such a way as that all sorts of refuse articles might be readily conveyed to them by pipes or other contrivances. When at a distance, they should be so placed as that the servants need not enter the farm-yard in feeding them. It is a circumstance of vast advantage in the economy of labor, as well as food, to have them conveniently situated and built. Though swine are generally, perhaps from a too partial view of their habits, considered as filthy animals, there are no animals which delight more in a clean and comfortable place to lie down in, and none that cleanliness has a better effect upon with respect to their thriving and feeding. In order to keep them dry, a sufficient slope must be given, not only to the inside places where they are to lie, but to the outside areas, with proper drains to carry off all moisture. The outsides should also be a little elevated, and have steps up from the areas of at least five or six inches in height. Hog-styes should likewise have several divisions, to keep the different sorts of swine separate; nor should a great many ever be allowed to go together; for it is found that they feed better in small numbers, and of equal size, than when many of equal sizes are put together. Proper divisions must, therefore, be made; some for swine when with the boar; others for brood swine, and for them to farrow in; for weaning the pigs, for keeping the store pigs, for fattening, &c. When convenient, the areas should be pretty large. And where it can be had, it is of great use to have water conveyed to them, as it serves many useful purposes.

2681. *Every sty should have a rubbing-post*. "Having occasion," says Marshal, "to shift two hogs out of a sty without one, into another with a post, accidentally put up to support the roof, he had a full opportunity of observing its use. The animals, when they went in, were dirty, with broken ragged coats, and with dull heavy countenances. In a few days, they cleared away their coats, cleaned their skins, and became sleeky haired; the enjoyments of the post were discernible even in their looks, in their liveliness, and apparent contentment. It is not probable, that any animal should thrive while afflicted with pain or uneasiness. Graziers suffer single trees to grow, or put up dead posts in the ground, for their cattle to rub themselves against; yet it is probable that a rubbing-post has never been placed intentionally in a sty; though, perhaps, for a two-fold reason, rubbing is most requisite to swine." In farm-yards the piggeries and poultry houses generally occupy the south side of the area, in low buildings, which may be overlooked from the farmer's dwelling-house. They should open behind into the straw-yards or dung-heap, to allow the hogs and fowls to pick up the corn left on the straw, or what turnips, clover, or other matters are refused by the cattle. They should have openings outwards, that the pigs may be let out to range round the farmery at convenient times; and that the poultry may have ingress and egress from that side as well as the other.

2682. *Poultry houses* are generally slight structures for rearing and feeding domestic fowls. Beaton (*Com. to the Board of Ag.* vol. i.) is of opinion, that poultry ought always to be confined, but not in a close, dark, diminutive hovel, as is often the case; they should have a spacious airy place, properly constructed for them. Some people are of opinion, that each sort of poultry should be kept by itself. This, however, is not, he says, absolutely necessary, for all sorts may be kept promiscuously together, provided they have a place sufficiently large to accommodate them conveniently, and proper divisions and nests for each kind to retire to separately, which they will naturally do of themselves. Wakefield of Liverpool keeps a large stock of turkeys, geese, hens, and ducks, all in the same place: and although young turkeys are in general considered so difficult to bring up, he rears great numbers of them in this manner every season, with little or no trouble whatever. For this purpose he has about three quarters, or near a



whole acre, inclosed with a fence only six or seven feet high, formed of slabs set on end, or any thinnings of fir or other trees split and put close together. They are fastened by a rail near the top and another near the bottom, and are pointed sharp, which he supposes prevents the poultry flying over, for they never attempt it, although so low. Within this fence are places done up slightly (but well secured from wet) for each sort of poultry; also a pond or stream of water running through it. These poultry are fed almost entirely with potatoes boiled in steam, and thrive astonishingly well. The quantity of dung that is made in this poultry place is also an object worth attention: and when it is cleaned out, a thin paring of the surface is at the same time taken off, which makes a valuable compost, for the purpose of manure. But for keeping poultry upon a small scale, it is only necessary to have a small shed or slight building, formed in some warm sheltered sunny situation, if near the kitchen or other place where a constant fire is kept so much the better, with proper divisions, boxes, baskets, or other contrivances for the different sorts of birds, and for their laying and incubation.

2683. *When a few poultry* that take their chance at the barn-door, are kept by the farmer for the convenience of eggs, and not to go to market when a fowl is wanted, no particular attention is requisite; but as, in some situations, they may pay well for more food and closer attention, other circumstances may be noticed. "The poultry-house should," Young says, "contain an apartment for the general stock to roost in, another for setting, a third for fattening, and a fourth for food. If the scale is large, there should be a fifth, for plucking and keeping feathers. If a woman is kept purposely to attend them, she should have her cottage contiguous, that the smoke of her chimney may play into the roosting and setting rooms; poultry never thriving so well as in warmth and smoke; an observation as old as Columella, and strongly confirmed by the quantity bred in the smoky cabins of Ireland. For setting both turkeys and hens, nests should be made in lockers, that have lids with hinges, to confine them, if necessary, or two or three will, he says, in sitting, crowd into the same nest. All must have access to a gravelled yard, and to grass for range, and the building should be near the farm yard, and have clear water near. Great attention should be paid to cleanliness and whitewashing, not for appearance, but to destroy vermin."

2684. *The interior arrangement of a poultry house* for a farm-yard, is generally very simple, and consists of little more than a number of spars reaching across the building at different heights, or the same height with a gangway or ladder attached, for the fowls to ascend: but where comfort and cleanliness is studied, a preferable mode is to form a sloping stage of spars (fig. 355 a, b), for the poultry to sit on; beneath this stage may be two ranges of boxes for nests (c, c); the roof (d) should have a ceiling to keep the whole warm in winter, and the door (e) should be nearly as high as the ceiling for ventilation, and should have a small opening with a shutter at bottom, which, where there is no danger from dogs or foxes, may be left open at all times to admit of the poultry going in and out at pleasure, and especially for their early egress during summer. The spars on which the clawed birds are to roost, should not be round and smooth, but roundish and roughish, like the branch of a tree. The floor must be dry, and kept clean for the web-footed kinds.

355

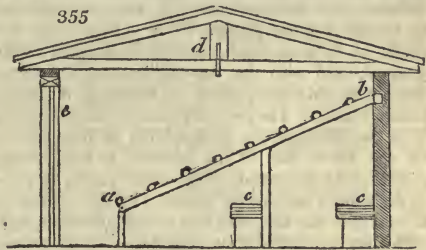

2685. *The rabbitry* is a building of rare occurrence in agriculture, and where it is required differs little from the piggery, consisting of a yard for exercise and receiving food, and a covered close apartment connected, for repose, sleep, and the mothers and young. In the latter are generally boxes a foot or more high and wide, and divided into compartments of two or more cubic feet for the rabbits to retire into, and bring forth their young. Where young rabbits are fed for the market, the mother and offspring are generally confined to hutches, which are boxes a little larger than the common breeding boxes, and kept in a separate apartment. In treating of the rabbit (Part III.) these and other contrivances for the culture of this animal, will be brought into notice.

356

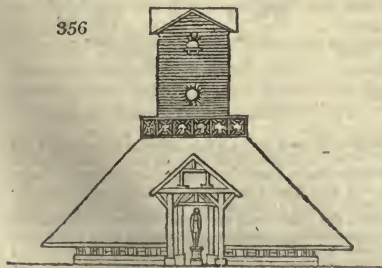

2686. *The pigeonry* is a structure not more frequent than the rabbitry, being scarcely admissible in professional agriculture, excepting in grazing districts, where the birds have not so direct an opportunity of injuring corn. Sometimes they are made an ornamental appendage to a proprietor's farmery, or to a sheep-house in a park (fig. 356.); and sometimes a wooden structure, raised from the ground on one or more posts, is formed on purpose for their abode. Whatever may be the external form, the interior

arrangement consists of a series of boxes or cavities, formed in or against the wall generally about a foot high and deep, and two feet or less long; one half of the front is left open as an entrance, and the other is closed to protect the female during incubation. (See *Pigeon*, Part III.)

2687. *The apiary* is a building or structure seldom wanted, excepting to protect hives from thieves; then a niche or recess in a wall to be secured in front by two or more iron bars, is a simple and effectual mode. Sometimes apiaries are made ornamental (fig. 357.), but the best bee masters set little value on such structures, and prefer keeping their bees detached in single hives for sufficient reasons. These hives may be chained to fixed stools in Huish's manner. (See *Bee*, Part IV.)

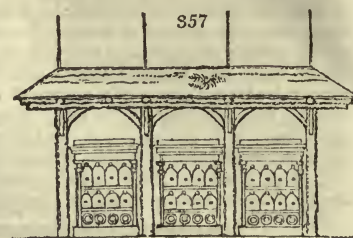

## SECT. II. Buildings as Repositories, and for performing in-door Operations.

2688. *Buildings for dead stock and crop* occupy a considerable portion of the farmery, and include the barn, granary, straw and root-houses, cart-sheds, tool-house, harness-room, and when farming is conducted on a very extensive scale, the smiths' and carpenters' work-rooms.

2689. *The corn barn*, or building for containing, threshing, and cleaning corn, has undergone considerable change in form and dimensions in modern times. Formerly it was in many cases made so large as to contain at once all the corn grown on a farm; and in most cases it was so ample as to contain a great portion of it. But since the mode of forming small corn stacks became more general, and also the introduction of threshing machines, this description of building is made much smaller. The barn, especially where the corn is to be threshed by a machine, is best placed on the north side of the farmery, as being most central for the supply of the straw yards, as well as the stables and cattle sheds. In this situation it has also the best effect in an architectural and picturesque point of view (fig. 358.) Suppose an octagon form chosen for a farmery with the barn (1), straw-room and granary over (2), and mill-shed (3), to the north; then on the left of the barn may be the stable for work-horses (4), and riding-horse stable (5), cattle-house (6), cow-house (7), sick horse (8), sick cow (9), cattle-sheds (10), cart-shed (11), boiling and steaming house (12), root-house (13), chaff and other stores for steaming, or mechanic's work-shop (14), piggeries (15), poultry and rabbiting (16). The yard may be divided in two by a wall running north and south, with a pump, well, or other supply of water in the centre (17). The rick-yard (27), should be to the north of such a farmery for easy conveyance to the barn: the main entrance (28) should be from the south opposite the dwelling-house; side entrances (26) should lead to different parts of the farm and to the main roads of the country, and there should be ponds (25) for washing the horses' feet and for the poultry. We have elsewhere shown the same accommodations arranged in a square and circular outline (780.)

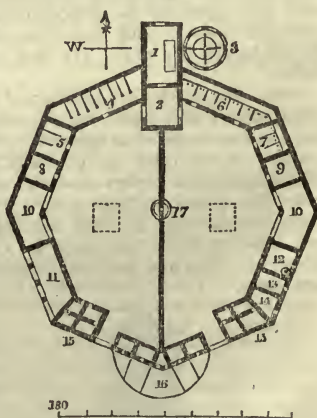
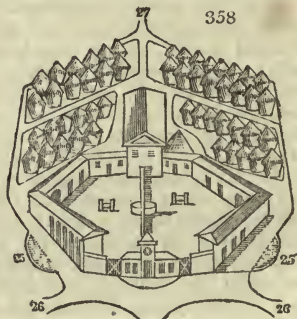

2690. *The English corn barn* for containing a large quantity of corn in the straw, and for threshing it out by flails, may either be constructed on wooden frames covered with planks of oak, or be built of brick or stone, whichever the country affords in the greatest plenty; and in either case there should be such vent-holes, or openings in their sides or walls, as to afford free admittance to the air, in order to prevent the mouldiness that would otherwise, from the least dampness, lodge in the grain. The gable-ends are probably best of brick or stone, on account of greater solidity; the whole may be roofed with either thatch or tiles, as can be most conveniently procured. It should have two large folding-doors facing each other, one in each side of the building, for the convenience of carrying in or out a large load of corn in shaves; and these doors should be of the same breadth with the threshing-floor, to afford the more light and air; the

former for the threshers, and the latter for winnowing. Over the threshing-floor, and a little above the reach of the flail, poles are often laid across from one beam to another, to form a kind of upper-floor, upon which the thresher may throw the straw or haulm, to make an immediate clearing, till he has time to stow it properly elsewhere: and on the outside, over the great doors, it is sometimes convenient to have a large pent-house, made to project sufficiently to cover a load of corn or hay, in case a sudden storm should come on before it can be housed; and also to shelter the poultry in the farm-yard in great heat or bad weather. It was formerly the custom in countries that abounded in corn to have separate barns for wheat, for spring-corn, such as barley and oats, and for peas, tares, lintels, clover, saintfoin, &c. but where the grain can be stacked, the heavy expense of so many buildings of this kind may be avoided. On no description of farm buildings has so much needless expense been incurred as in barns. The most ostentatious in England are those on Coke's estate in Norfolk; they are built of fine white brick, so large and unscientifically constructed that they cannot be filled with corn from the fear of bursting the side walls. . . .

2691. *The threshing-floor or space, on which the grain is threshed out by the flail, is an important object in the English barn.* It is for the most part made in the middle of the building, but may be laid down in any other part, if more convenient, and should always be so formed as to be perfectly close, firm, and strong. In constructing these kinds of floors, various sorts of materials are employed, such as compositions of different earthy kinds, stones, lumps, bricks, and wood. The last substance, when properly laid and put together, is probably the best and most secure from damp. When made of wood, they are sometimes so contrived as to be moveable at pleasure, which is a great convenience in many cases: they are made of different dimensions, but from twelve to fourteen by eighteen or twenty feet, are in general proper sizes for most purposes.

2692. *Threshing-floors in Gloucestershire*, Marshal observes, are of a good size, when from 12 to 14 by 18 to 20 feet. The best of oak, some of stone; but a species of earthen floor, which is made there, is thought to be superior to floors of stone, or any other material, except sound oak-plank. The superior excellency of these floors is owing in part to the materials of which they are formed, and in part to the method of making them. In order to this, in some places, the surface of the intended threshing-place is dug away to the depth of about six inches, and the earth thus taken out, when of a proper kind, after being well cleared of stones, is mixed with the strongest clay that can be procured, and with the dung of cattle. This mixture is then worked together with water, till it is of the consistence of stiff mortar, and the compost thus made is spread as smooth as possible with a trowel, upon the spot from whence the earth was taken. As it cracks in drying, it must frequently be beaten down with great force; or rolled with a heavy roller until all the crevices are filled up: and this must be continued till it is quite solid, hard, dry, smooth, and firm.

2693. *Boarded threshing-floors*, made of sound, thick, well-seasoned planks of oak, are excellent for service, will last a long time, and may be converted into good floorings for rooms, by planing them down, after they are become too uneven for the purpose originally intended.

2694. *Earthen threshing-floors* should not be advised, except where good materials can be procured, and the making of them be performed in the most perfect manner, which, as we have noticed (2692.) is only the case in particular instances and districts.

2695. *Brick floors*, when well laid down, may, in some cases, make a tolerable floor for many purposes, but on account of their not only attracting, but retaining moisture, they are not to be recommended, where grain of any kind is to continue much upon them.

2696. *In constructing wooden floors* the most usual mode is that of nailing the planks, or boards of which they are composed, after their edges have been shot true, and well fitted and jointed, close down to wooden joists or sleepers, firmly placed and secured upon the ground, or other place for the purpose. But in the midland districts, instead of the planks being nailed down to sleepers in the ordinary way, the floor is first laid with bricks, and the planks spread over these, with no other confinement than that of being "dowled" together, that is, ploughed and tongued, and their ends let into sills or walls, placed in the usual way, on each side the floor. By this method of putting down the planks, provided the brick-work be left truly level, vermin cannot have a hiding-place beneath them; and a communication of damp air being effectually prevented, floors thus laid are found to wear better than those laid upon sleepers. It is observable that the planks, for this method of laying, ought to be thoroughly seasoned. It is evident, however, that where barn-floors can be made hollow, they must be much better for the purpose of threshing upon, than such as are either placed on brick-work, or the ground. From their greater pliability and elasticity in threshing upon, the grain is of course threshed out with more ease, certainty, and dispatch.

2697. *The threshing-mill barn* is not restricted to any size; but it answers best when the ground-plan is a parallelogram, the width from 20 to 30 feet, according to the size of the machinery, and the height from 15 to 20 feet, in order to allow one winnowing machine or even two to be placed under the threshing part of the machinery. The barn in this case is in three distinct divisions: the first, for the unthreshed corn, should be of such a size as to contain an ordinary stack, and, if possible, it should be so contrived as to be entered by a loaded cart; which, whether the corn be threshed as carried in, or be laid up for future operations, is a great saving of labor. The second division contains the machinery and the corn floor, and should be enclosed with boards so as to be locked up when not in use. The third division is the straw barn, which should be so large as to admit of keeping a considerable quantity of different kinds of straw separately, accessible for fodder and for litter.

2698. *The hay-barn* is commonly constructed of timber, and sometimes is open on the south or east, or even on all sides. In Middlesex, there are many hay-barns capable of holding from 30 to 50, and some even 100, loads of hay. They are found to be extremely useful and convenient during a catching and unsettled hay-harvest, and also at other seasons of the year. In wet and windy weather, they afford an opportunity of cutting, weighing, and binding hay; none of which operations could, at such a time, be performed out of doors. Most farmers agree that hay may be put together earlier, even by a day, in a barn, than it would be safe to do in a stack. They advise, however, that the sides of the mow should be raked or pulled, clear of the quartering of the barn; and, when thus managed, they are of opinion, that the hay will be as good in the barn as in the

stack. In the driest seasons, barns are a saving, and, in wet seasons, the ready assistance which they afford, in speedily securing the hay, has been known to make a difference in price of twenty shillings per load. Many persons, on the other hand, think hay is more apt to heat in a barn than in the open air; and that they present no advantages which may not be obtained by the canvass stack cover. If they do not possess considerable advantages, then the loss must be great, as the erection of such barns is a heavy expense.

2699. *The granary*, in barns with threshing machines, is almost always formed immediately above the floor on which the machine works; and which, among other advantages, admits raising the corn to it directly from the ground-floor, either by the threshing-mill itself, or a common windlass, easily worked by one man. When it is to be taken out and carried to market, it may be lowered down upon carts, with the utmost facility and dispatch. There is evidently no greater expense incurred by this arrangement; for the same floor and height of side-walls that must be added to the barn, are required in whatever situation the granary may be; and it possesses several advantages. Owing to its being higher than the adjacent buildings there is a freer circulation of air, and less danger of pilfering, or of destruction by vermin; the corn may be deposited in it as it is dressed, without being exposed to the weather, while the saving of labor is in most cases considerable.

2700. *The construction of the agricultural granary* has in it nothing particular; being, in fact, only a well ventilated room, where corn is seldom kept more than a month or two, and generally in sacks.

2701. *A detached granary* often forms a part of farmhouses on a small scale: they should be built with firmness, and well secured from the entrance of vermin. In order to effect this last purpose, they should be raised, by means of stone pillars, about eighteen inches or two feet, and have a frame of some durable wood, with quarterings of timber, so placed as that they may be filled up closely with brickbats, and the inside made secure by being lined with thin boards nailed firmly to the different pieces of quartering. The floors must be made firm, close, and even: the outside may also be covered with boarding, if it be thought necessary, and the roof well tiled. There may be different floors or stories, according to the room required.

2702. *Of commercial corn granaries*, some of the most extensive are in Dantzic. They are seven, eight, or nine stories high, having a funnel in the midst of every floor, to let down the corn from one to another. They are built so securely, that, though every way surrounded with water, the corn contracts no damp, and the vessels have the convenience of coming up to the walls for their lading. The Russians in the interior of the empire preserve their corn in subterranean granaries, of the figure of a sugar-loaf, wide below, and narrow at top: the sides are well-plastered, and the top covered with stones. They are very careful to have the corn well dried before it is laid into these store-houses, and often dry it by means of ovens, their autumn being too short to effect it sufficiently.

2703. *A granary to preserve corn for many years* should be a dry cellar, deeply covered with earth; and after the corn is put in, hermetically sealed to exclude heat, air, and moisture, and preclude the possibility of the grain vegetating, or of the existence of insects or vermin. (See 1797.)

2704. *The root-house* is used for storing up or depositing potatoes, turnips, carrots, cabbages, or other roots or tops for the winter feed of cattle. It should always join the cattle-sheds, and communicate with them by an inner door that opens into the feeder's walk along the heads of the cattle. The entrance door ought to be so large as to admit a loaded cart. These houses are essentially necessary wherever there is a number of cows or other sorts of cattle to be supported on roots of the carrot, parsnip, turnip, and potatoe kinds, as well as for cabbages, as without them it would not only be inconvenient, but in many cases in severe weather impossible to provide them for the daily supply of such stock. Cabbages should not, however, ever be kept long in houses, as they are very apt to take on the putrid fermentation, and become useless. The master should be careful that the yard-man constantly keeps such places perfectly clean and sweet, in order that the roots may contract no bad smell, as cattle are in many cases extremely nice in their feeding, and when once disgusted with any sort of food, seldom take to it again in a proper manner.

2705. *The steaming-house* should be placed next the root-houses for obvious reasons; and have an inner door communicating with it in a line with the door of the feeder's walk.

2706. *The straw-house* or straw-shed, when there is one distinct from the barn, should be placed at the end of the cattle-sheds, opposite to the root-house, and like it should have a cart entrance, and an inner door communicating with the feeder's walk. Straw, however, is often stacked, in preference to placing it in a straw-house, especially when large quantities of corn are threshed at one time.

2707. *Cart-sheds* or lodges, for the shelter and protection of carts or waggons, and

other large implements, are generally built close on three sides, with the fourth open, and the roof supported with posts or pillars. Sometimes they are open on all sides; but this admits too much wind, which carries moisture with it in the cold seasons of the year, and dries up and shrinks wooden articles in summer. Their situation in the square should be apart from the buildings for live stock, and also the barn, straw, and root-houses: generally the first part of the east or west side on entering, is devoted to the purpose of cart-sheds and tool-houses.

2708. *The tool-house* is used for keeping the smaller implements used in manual labor in the fields, as spades, rakes, forks, &c. It is essential that this apartment be dry and free from damp; and when convenient, it should have a loft for the better preservation of sacks, cordage, sowing sheets, baskets, spare harness, &c.

2709. Some *other buildings*, besides those of this and the preceding section, will be wanted in most farm-yards of any extent, as stables for young horses, riding-horses, an hospital stable, &c. Particular descriptions of farms also require appropriate buildings, as dairies, cheese-rooms, hop kilns, and wool-lofts, which will be considered in treating of dairy farms, hop culture, the management of sheep, &c.

2710. *Sleeping-rooms* for single men should be made over the stable, and for the feeder or cow-keeper, over the cattle-sheds; that they may hear any accident which takes place among the horses or cattle during the night, and be at hand to remedy it.

2711. *A smithy and carpenter's work-room* sometimes form part of the buildings on a large farm. Instead of going to a distance to the residence of these necessary mechanics, arrangements are made with them to attend at stated periods or when sent for, by which a saving both of time and money is effected. Sometimes these buildings are set down at a little distance from the square to prevent danger from fire, and lessen the expense of insurance. The fixtures, as the anvil, bellows, bench, vice, lathe, &c. and some of the larger tools, belong to the farmer, but the others the mechanics bring with them. A small stock of iron, steel, and timber, is kept to be in readiness, and also the cast-iron work of ploughs, carts, &c. and sometimes the smaller pinions, and other parts of the threshing machines.

### SECT. III. *Of the Farmer's Dwelling-House.*

2712. *The dwelling-house of the farmer* is generally detached from the farmery on the south side, and separated from it by a road, grass-plot, garden, or pond, or all of these, according to circumstances. In size and accommodations it ought to be proportioned to the capital requisite for the farm; that is, it ought to be on a par with the houses of other members of society of similar property and income. In design it ought to be simple and unostentatious; utility and convenience being its recommendatory beauties. At the same time, as observed in the *Code of Agriculture*, "every landlord of taste, in fixing on the site and plan of a new farm-house and offices, ought certainly not to overlook the embellishment of the country." How much of the beauty of a country, and of the ideas of the comfort and happiness of its inhabitants, depends on the appearance of its farm-houses and cottages, every traveller is aware; and every agriculturist who has travelled through the British isles, can recognize at once a well cultivated district by the forms of the farm-yards, and the position of the farmer's dwelling-house. The difference between the best and worst cultivated English counties in this respect are sufficiently striking; and the ideas of wealth, comfort, order, and scientific agriculture, which the farmers and cottages of Northumberland and Berwickshire excite in the mind, are totally unfelt in passing through even Hertfordshire and Essex; where the scattered, straggling hovels of all sizes and shapes, the monstrous barns, and rickety, shapeless farm-houses, indicate a low state of culture, and an ignorant, tasteless set of occupiers. Even in Norfolk and Suffolk, the want of symmetry in the farmeries of opulent farmers, is every where conspicuous, and the want of taste and decorum in setting the dwelling-houses among dung heaps and urine ponds, no less so. But the farmers in Norfolk, as in most parts of England, though wealthy, are in general ignorant and gross in their habits and taste. They are accustomed to look on themselves as an order of beings different from the trading classes of the community, superior as possessing houses and land, and inferior as not daring to enjoy wealth or better their condition beyond a certain extent, lest the landlord should raise their rent. Till this feeling, which is one among other vestiges of feudal times, and the metayer system, is more or less done away both on the part of the landlord and tenant, no great improvement in farm-houses can be expected.

2713. In selecting a few *examples of farm-houses*, the first we shall notice is that of the smallest size where the farmer keeps no servant and cultivates only a few acres. The ground plan of such a house (*fig. 359.*) should contain an entry (*a*); kitchen (*b*); dairy and pantry (*c*); parlour (*d*); light closet off the parlor as a store-room, or for a

bed (e); tool-house (f); stair and cellar under (g); water closet, and poultry-house over (h); there are three bed-rooms in the roof, and one garret. The dimensions may be varied at pleasure; but twelve feet square is the least dimension that can be given to the kitchen and parlors.

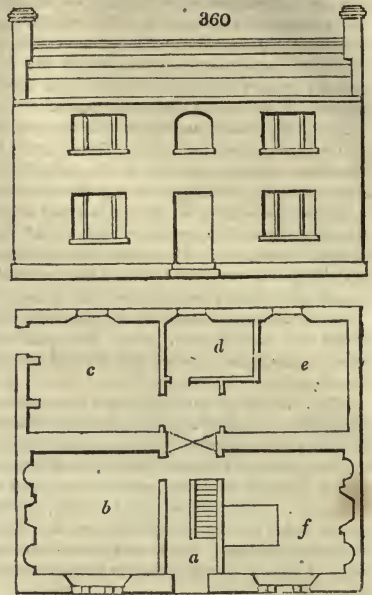
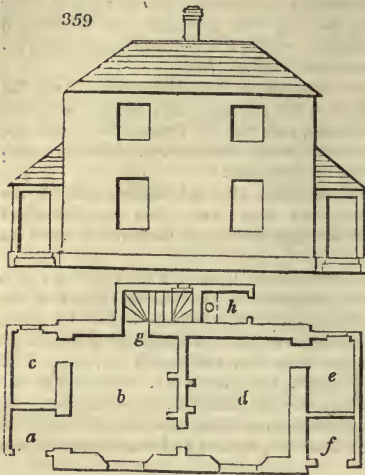

2714. A farm-house of the smallest size (fig. 360.), where the poultry and tool house are in the farm-yard, but where the farmer keeps only one servant, and works and lives with him, may contain an entrance and stair (a); kitchen, closet, and oven (b); back kitchen (c); dairy (d); parlor (e); bedroom (f); with three bedrooms and a garret up stairs, and a cellar under. A few of such farm-houses and tenants should be found in all parts of the country, if for no other reason than to preserve the gradation from the laborer to the professional farmer, and from the cottage to the farm-house.

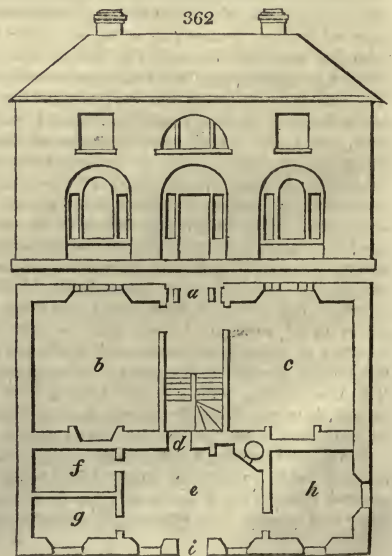
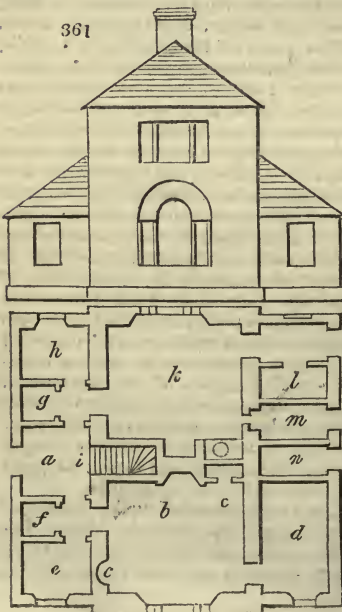

2715. *A farm-house larger than the preceding (fig. 361.), and for a farmer and his family rather in a better style, may contain a principal entrance and lobby (a); parlor (b); closets (c); store-room for meal, cheese, &c. (d); lumber room for small implements (e); beer cellar (f); pantry (g); dairy (h); staircase (i); kitchen, with an oven under the stairs, and a boiler on the other side of the fire place (k); coals or wood, and back-entry (l); pig-stye, with a small opening towards the kitchen for throwing in dish-water, offals, &c. (m); and poultry-house (n); with two garret bedrooms over the wings; two good bedrooms and a closet up stairs, and a garret in the roof.*

2716. *A farm-house of the second lower scale (fig. 362.), executed at Burleigh in Rutlandshire, contains a principal entry (a); parlor (b); kitchen (c); stair (d); dairy (e); pantry (f); cellar (g); and cheese-room (h). The three latter are attached to the back part of the house by a continuation downwards of the same roof. By making their ceilings only seven and a half or eight feet high, some small bed-rooms may be got above them, having a few steps down from the floor of the front rooms, or a few steps up from the first landing-place. The back-door of the kitchen enters into a brew-house and wash-house, the fire place and copper being behind the kitchen vent. Beyond this brew-house is a place for holding fire-wood, &c.; in the back wall of which are openings to feed the swine. In the kitchen is an oven; and below the grate a very good contrivance for baking occasionally, but principally used for keeping the servants' meat warm. It consists of a cast-iron plate, and door like an oven. The chamber-floor is divided into two rooms for wards, and two small ones backwards.*

2717. *Farmers' dwelling-houses, containing more accommodation and comfort, and displaying appropriate taste and expression of design, will be found in a succeeding section, where farmeries are treated of, and also where we treat of laying out farms. (Part III.)*

SECT. IV. *Of Cottages for Farm Servants.*

2718. *Cottages for laborers are necessary appendages to every farm or landed estate, and no improvement is found to answer the purpose better than building these on a comfortable and commodious plan. In the southern counties of the island, where the farmer's laborer is supposed to change his master once a year, or oftener, the whole business of cottages is commonly left to accident; but in the north a certain number of married servants are kept on every farm, and a fixed place near the farmery is appointed for their situation. These habitations are in the tenure of the farmer, in common with the other buildings of the farm; and whenever a married servant changes his master he changes his habitation.*

2719. *The accommodation formerly considered suited for farm laborers, consisted of two rooms. That on the ground floor not being less than twelve feet square, with a sleeping room of the same size over, and sometimes on the same floor. But this is justly deemed too small for an ordinary laborer's family. "Humanity," Beatson observes, "shudders at the idea of an industrious laborer, with a wife, and perhaps five or six children, being obliged to live, or rather exist, in a wretched, damp, gloomy room, of 10 or 12 feet square, and that room without a floor; but common decency must revolt at considering, that over this wretched apartment there is only one chamber, to hold all the miserable beds of this miserable family. And yet instances of this kind, to our shame be it spoken, occur in every country village. How can we expect our laborers or their families to be healthy, or that their daughters, from whom we are to take our future female domestics, should be cleanly, modest, or even decent, in such wretched habitations?"*

2720. *Cottages for farm servants, it is observed by the able author of the article Agriculture, in the Supplement to the Encyc. Britannica, "are usually set down in a line, at not an inconvenient distance from the farm-yard. Each of them contains two apartments, with fire-places and garret sleeping rooms over. Adjoining is commonly a cow-house, hog-stye, shed for fuel, necessary, a small garden, and sometimes other appendages of comfort and enjoyment. As an example of the minimum of modern*

*accommodation, we may refer to two cottages on a farm in Berwickshire, as described in the report of that county. They contain each a kitchen (fig. 363 a.) small parlor and store-room (b), with two good bedrooms over, and a dairy under the staircase. — There is a garden behind*

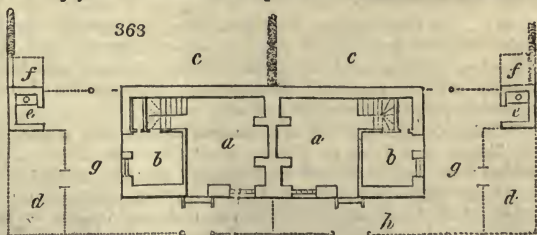

(c), a place for a calf or pigs, or for fuel (d), water-closet (e), and dung-heap (f). The laborer's cows, in this case, are kept at the farmery along with those of the farmer.

2721. *A double ploughman's cottage and cow-house (fig. 364.)* may be thus arranged. Both may contain a kitchen (a) with an oven, and there may be a small parlor or store-room (b), a dairy and pantry (c), with two bed-rooms over. Detached may be a pig-stye (d), water-closet (e), place for fuel (f), and cow-house (g), with gardens adjoining, dung-heap, porch, step-up, &c. as in the other place.

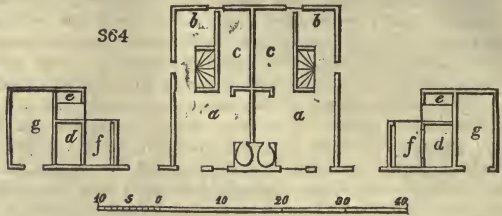

2722. In regard to the construction of cottages much information may be obtained from a work entitled, *A Series of Plans for Cottages*, by J. Wood, of Bath. This author lays down the following seven principles, as the means of obviating the inconveniencies to which cottages, as usually built, are liable:—



2723. *The cottage should be dry and healthy*; this is effected by keeping the floor sixteen or eighteen inches above the natural ground; by building it clear of banks, on an open spot of ground, that has a declivity or fall from the building; by having the rooms not less than eight feet high—a height that will keep them airy and healthy; and by avoiding having chambers in the roof.

2724. *They should be warm, cheerful, and comfortable.* In order to attain these points, the walls should be of a sufficient thickness (if of stone, not less than sixteen inches; if of brick, at least a brick and a half) to keep out the cold of the winter, or the excessive heat of the summer. The entrance should be screened, that the room, on opening the door, may not be exposed to the open air; the rooms should receive their light from the east or the south, or from any point betwixt the east and the south; for, if they receive their light from the north, they will be cold and cheerless; if from the west, they will be so heated by the summer's afternoon sun, as to become comfortless to the poor laborer, after a hard day's work; whereas, on the contrary, receiving the light from the east or the south, they will be always warm and cheerful. So like the feelings of men in a higher sphere are those of the poor cottager, that if his habitation be warm, cheerful, and comfortable, he will return to it with gladness, and abide in it with pleasure.

2725. *They should be rendered convenient*, by having a porch or shed, to screen the entrance, and to hold the laborer's tools; by having a shed to serve as a pantry, and store-place for fuel; by having a privy for cleanliness and decency's sake; by a proper disposition of the windows, doors, and chimneys; by having the stairs, where there is an upper floor, not less than three feet wide, the rise or height not more than eight inches, and the tread or breadth not less than nine inches; and, lastly, by proportioning the size of the cottage to the family that is to inhabit it; there should be one lodging-room for the parents, another for the female, and a third for the male children; it is melancholy, he says, to see a man and his wife, and sometimes half a dozen children, crowded together in the same room, nay, often in the same bed; the horror is still heightened, and the inconveniency increased, at the time the woman is in child-bed, or in case of illness, or of death; indeed, whilst the children are young under nine years of age, there is not that offence to decency, if they sleep in the same room with their parents, or if the boys and girls sleep together, but after that age they should be kept apart.

2726. *Cottages should not be more than twelve feet wide in the clear*, that being the greatest width that it would be prudent to venture the rafters of the roof, with the collar-pieces only, without danger of spreading the walls; and by using collar-pieces, there can be fifteen inches in height of the roof thrown into the upper chambers, which will render dormer-windows useless.

2727. *Cottages should be always built in pairs*, either at a little distance from one another, or close adjoining, so as to appear one building, that the inhabitants may be of assistance to each other, in case of sickness or any other accident.

2728. *For economy, cottages should be built strong*, and with the best of materials, and these materials well put together; the mortar must be well tempered and mixed, and lime not spared; hollow walls bring on decay, and harbour vermin; and bad sappy timber soon reduces the cottage to a ruinous state. Although cottages need not be fine, yet they should be regular; regularity will render them ornaments to the country, instead of their being, as at present, disagreeable objects.

2729. *A piece of ground should be allotted to every cottage*, proportionable to its size; the cottage should be built in the vicinity of a spring of water—a circumstance to be attended to; and if there be no spring, let there be a well.

2730. *On the foregoing seven principles*, he recommends all cottages to be built. They may be divided into four classes or degrees: first, cottages with one room; secondly, cottages with two rooms; thirdly, cottages with three rooms; and, fourthly, cottages with four rooms; plans of each of which, that have great merit in their distribution, may be seen in his very able work.

2731. *An economical mode of constructing the walls of brick-built cottages*, is described by Dearn, in a *Tract on Hollow Walls* (London, 1820). These walls are only nine inches wide, and built hollow, by laying the courses alternately lengthways on edge, and crossways on the broad face. Another description of hollow walls has been invented by Silverlock of Chichester, and used by him in building garden walls (See *Encyc. of Gardening*), in which all the bricks are laid on edge, but alternately lengthways and crossways of the wall; or, in bricklayers' language, header and stretcher.



Either of these modes suit very well for cottages of one story, and if well plastered inside the house, they will be warmer and dryer than solid walls even of fourteen inches thickness. Hollow walls of any height may be built by laying the bricks flat ways, and joining the outer and inner four inch, or single brick walls, by cross bricks at moderate distances.

2732. *An economical mode of forming staircases to cottages*, is described by Beatson, and has been adopted in a few places. Its merit consists in occupying exactly half the room which is required for stairs on the ordinary plan. This is effected by dividing every step into two parts (fig. 365 *a* and *b*), and making one part double the height of another. In ascending such a stair the left foot is set on the left step (*a*), and the right foot on the right step (*b*), alternately to the top of the stair. It is therefore clear, that as the steps for the right and for the left foot are in the same line, and although neither foot rises each time higher than seven inches and a half above the other, yet every time that one foot is moved, it rises fifteen inches higher than it was before. Suppose in a stair of this kind, that each tread or breadth for the foot is nine inches, and that each rise of the one foot above the other is seven inches and a half, consequently as each foot rises the height of two steps, or fifteen inches, every time it is moved, it is plain that six steps of this kind will rise as high as twelve in the common way, and will require only one half the size of a hatch or opening in the floor above, that would be required for those twelve steps as usually constructed. This will be of considerable advantage, where much is required to be made of little room, and will of course give more space to the chambers above; but it has the disadvantage of being disagreeable, and even dangerous to descend, especially for pregnant women and young children.

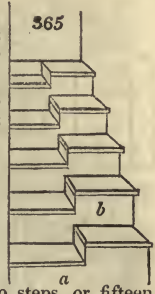

2733. *Mud walls*, built in the French manner, or *en pisé*, are recommended by Beatson, Crocker, and others, and also "walls composed of soft mire and straw," but these we consider, with Wood, as the reverse of economical in the end, and totally unfit for our climate and degree of civilization.

2734. Of what are called *ornamental cottages for laborers*, we shall say little. Utility is a beauty of itself, but there are higher degrees of that sentiment excited by the appearance of convenience and abundance; by the evidence of design or intelligence in the contriver as displayed in the elevation and general effect, and by classical imitative or picturesque forms in the masses and details. The great evil, however, is that these ornamental cottages, as generally constructed, are felt by the occupiers to be very uncomfortable habitations, every thing being sacrificed by the designer to external appearance. This is in the very worst taste, and has, in most parts of the country, brought ornamental cottages into ridicule. Utility, therefore, is the main consideration, and nothing ought to be considered as ornamental that is at all at variance with this property.

2735. *As an example of a cottage ornamented in the least degree* (fig. 366.) we submit a specimen in the gothic style, by Holland. It contains an entrance lobby, and stair (*a*), kitchen (*b*), small parlour and store-room (*c*), cow-house (*d*), pig-stye (*e*), poultry (*f*), and water closet (*g*). Over the kitchen is a bed-room with a fire place, and another communicating with it over the cow-house.



2736. *A cottage ornamented in the second degree* (fig. 367.), contains an entrance and lobby (*a*), kitchen (*b*), stair (*c*), parlor, or store-room (*d*), back kitchen (*e*), cow-house (*f*), and water closet (*g*), with two good bed rooms over the centre of the building, and two garrets over the wings.

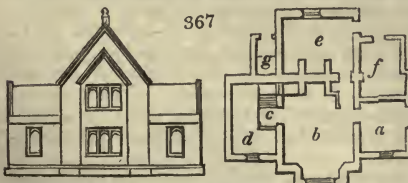

2737. *A double ornamental cottage*, erected by Lord Penryhn, in Wales (fig. 368.), contains a porch, lobby, and stair (*a*), kitchen and living room (*b*), parlor (*c*), with cellars and pantry under, and to each house two bed-rooms over. It must be confessed, however, that this cottage is more ornamental than convenient.

2738. *A double ornamental cottage, with latticed windows* (fig. 369.), built in Hertfordshire, on a very dry soil, contains, on the ground floor, the kitchen and living room (*a*), pantry (*b*), and small light closets (*c*), with a stair up to two good bed-rooms above and down to a dairy, cellar, fuel-room, and other conveniences beneath. It is placed in a

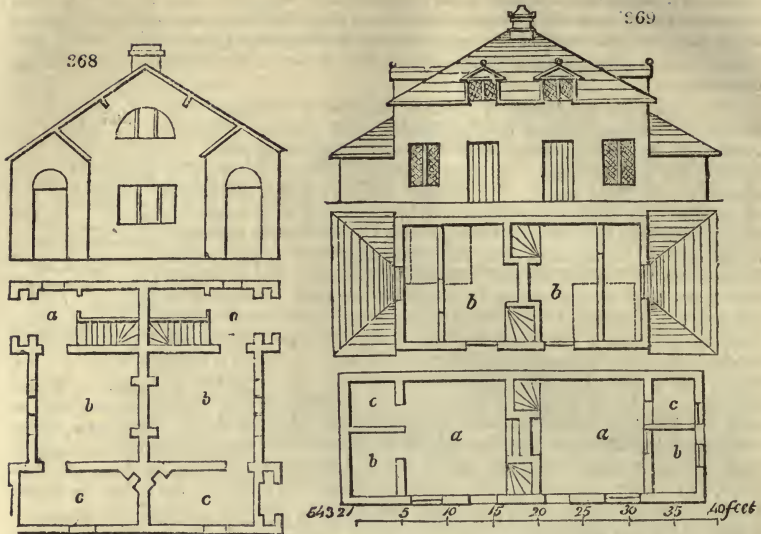

neat garden, with piggery, bee-house, poultry, dung-pit, water closet, covered seat or bower, pump-well, and other appendages to each cottage.

2739. *A variety of other plans of cottages will be found connected with the plans of farmeries, and in our Topography of Agriculture (Part IV.)*

SECT. V. *Of the Stack-yard, Dung-yard, and other Enclosures immediately connected with Farm Buildings.*

2740. *The different appendages which are common to farm buildings are the dung-yards, pits and reservoirs, the rick-yard, the straw-yard, the poultry-yard, drying yard, garden, orchard, and cottage-yards. These necessarily vary much, according to situation and other circumstances, but all of them are more or less essential to a complete farmery.*

2741. *The dung-yard and pit is placed in almost every case in the centre of the main yard. A pavement, or causeway, ought to be carried round the yard, next to the houses, of nine or fifteen feet in width, according to the scale of the whole: the remaining part of the yard should either be enclosed with a wall with various doors to admit cattle, carts, and wheel barrows, or on a small scale, it may be entirely open. From this space the earth should be excavated so as to form a hollow deepest at the centre, or at the lower end if the original surface was not level; and from the lowest part of this hollow should be conducted a drain to a reservoir for liquid manure. The bottom of this excavation, or dung-basin, ought to be rendered hard, in order not to take the impression of cart wheels, in removing the dung, and impervious to moisture, in order to prevent absorption.*

2742. *For these purposes, it may be either paved, the stones being set on a layer of clay; or what will generally answer equally well, it may be covered with a thick coat of gravel or chalk, if it can be got, and then well-rolled, mixing some loam with the gravel, if it is found not to consolidate readily. To prevent as much as possible a superfluity of rain-water from mixing with the dung and diluting its drainings, all external surface-water should be prevented from entering the farm-yard by means of drains, opened or covered; and that which collects on the inner slopes of the roofs should, in every case, be carried off by gutters. Such is the opinion of most agriculturists as to the situation of the farm-yard, dung-hill, and reservoir; but, in addition to these requisites, it is now very properly considered as equally important that there be urine-pits, either open or covered.*

2743. *The urinarium, or urine-pit, is constructed in or near to the stables and cattle-sheds, for the immediate reception of the drainage of these buildings, unmixed with rain-water. It is found from experience that a very considerable addition of the richest kind of manure is thus obtained on every arable farm. At the same time it is proper to observe, that no benefit, but a loss, will be sustained if the urine is so completely drained from the straw, as to leave it too dry for fermentation. Where there are no stall-fed cattle, an able author (*Supp. En. Brit. i. 121*) is of opinion there will be no more urine than what will be required for converting the straw into manure. When*

cattle are fed at the stake, however, he considers a reservoir as essential. Allan, of Graycrook, near Edinburgh, recommends that there should be two, in order that as soon as one is full, it should remain in that state till the urine becomes putrid before it be taken away. The urine is either applied to the land in its liquid state, or mixed with peat, earth, &c. The reservoirs may be either vaults of masonry, or wells: in either case, the hole for the pump should be sufficiently large to admit a man to clean out the sediment when it accumulates. A very desirable plan seems to be, to have these vaults, or wells, chiefly within the cattle-house, as in Flanders, but partly also without, to admit room for the pump-hole, close by the wall on the inside of the surrounding paved road. It is needless to add, that such constructions ought to be made water-tight by the use of some cement, or by puddling with clay outside of the masonry.

2744. *The stack-yard*, or enclosure within which corn, hay, &c. is stacked, is placed exterior to that side of the building which contains the barn. Stack-yards should always be sufficiently spacious and airy, having a firm dry bottom; and some advise them to be ridged up, to prevent the accumulation of surface-water, as by the ridges being pretty well raised in the middle, and covering the places where the stacks are to be built, either with rough stones, with a mixture of gravel, or paving them in the same manner as streets, much advantage would be gained at little expense. But a much better method is to have them raised considerably above the surface, and placed upon pillars of wood or stone, with a covering of wood round the circumference, and beams laid across. The inclosing of stack-yards should be well performed, either by means of walls or palings, or better with a sunk fence; as in that way the stacks will have the full benefit of the air from top to bottom, a circumstance of no small moment, as it is often found, especially in wet seasons, where the fence of the stack-yards is only a low wall, that the whole of the stacks are damaged or spoiled as high up as the wall reaches, while the upper part is perfectly safe. Should any addition be required to the sunk-fence, a railing upon the top may be quite sufficient. This fully shows the vast advantage of having stack-yards sufficiently airy. The proper arrangement of the stands, for their being removed to the threshing-mill, is also a matter of much consequence in the economy of the work that is to be performed in them.

2745. *A stack-yard, arranged on principles peculiarly well planned and judicious*, has been formed by Mitchell, of Balquharn, near Alloa. His stacks are divided into regular rows, and there is a road on each side of every double row, besides a road round the whole yard. (See our *fig. 114.* and *115.*) This plan is attended with the following advantages; 1st, by these parallel roads, there is a greater degree of ventilation; 2dly, he can remove any stack he pleases, as necessity or markets require; 3dly, in the hurry of harvest there is no confusion or loss of time, whatever may be the number of men or horses employed; and 4thly, by having the rows and the stacks regularly numbered, there is no difficulty in ascertaining what each field of the farm produces.

2746. *Corn-stands* are requisite fixtures of the stack-yard: they are basements of timber or masonry, and sometimes of iron (*fig. 370 a.*), on which to build the stack, and their object is to keep the lower part of the stack dry, and exclude vermin. The usual mode of constructing stands is to place a stout frame of timber on upright stones, two feet high, and having projecting caps of flat stones. They are also constructed wholly of stone,

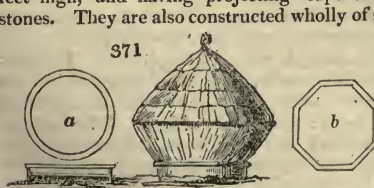
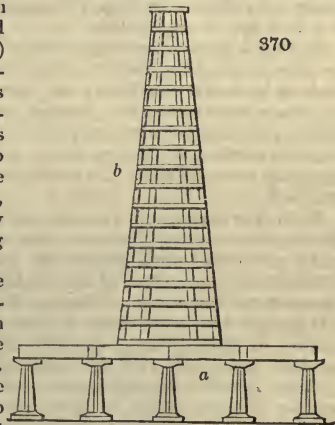

of circular or polygonal walls (*fig. 371 a, b*), built to the same height as in the former case, in a rather slanting manner outwards, and covered on the tops with copings of oak-planking or flat stones, which project over the edges several inches, and in that way prevent the ascent of rats and mice to the stacks. In both these modes, pieces of timber are placed as a frame in the middle to support the grain upon, and generally a cone of spars in the centre, to form a column of air in the heart of the corn. Some suppose the first of these sorts of corn-stands to be the best for general purposes, as being more easily as well as more cheaply constructed, and at the same time permitting the air to enter and circulate with more freedom

underneath, in the bottom of the stand, which is of much advantage. It is obvious that the form of these stands or basements must vary according to that in which the stacks are to be made, which is different in different districts. But wherever the threshing machine is introduced, the circular base, as producing a stack of a moderate size, with other advantages, is generally preferred.

2747. *Cast-iron stands for stacks* (fig. 372.) with or without funnels formed by hollow cones or triangles, have recently been introduced, and found advantageous in point of economy, and admitting of stacking the corn, somewhat earlier. The pillars of these stands are three feet high, and weigh one-half cwt. each. A stack requires seven pillars, besides the framing, which may either be made of poles or young trees. In the wet climate of Clackmannanshire, wheat has been stacked in five days, beans in eight, and barley and oats in ten days, and sometimes earlier. No vermin can find their way into these stacks to consume the grain, and the straw is better preserved. The cone or triangle keeps up a circulation of air, and prevents heating, or other damage. (*Gen. Rep. of Scotland*, vol. iv. *App.* p. 379.)

372

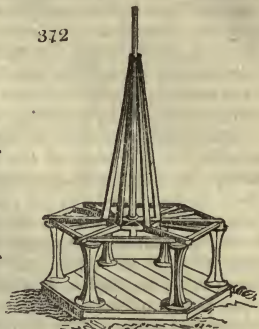

2748. *Hay-stands*, according to some, may be formed in the same manner as those for corn, only it is seldom necessary to have them made of such expensive materials. A simple frame of wood is mostly sufficient, with proper bearers laid across for the support of the stack. These stands are much better than the common practice of building the ricks on loose pieces of wood laid across in the bottom, and filled in with brush or faggot wood, as is often the case; and earthy floors or foundations should never be thought of for this purpose, as the dampness must injure a considerable part of the hay at the bottom. Where faggots are not scarce, however, and the ground on which a hay-stack is built is rather elevated, no stand can ever become necessary.

2749. *The stack-funnel* fausse or boss, as it is called in the north, whether the stand be of wood, iron, or stone, may be formed of a few poles placed on a circular (fig. 370 b.) square or angular base (fig. 372.), having a few short spars nailed across (fig. 370 b), or a straw rope wrapped round.

2750. *The stack-cover* is a cloth or canvass covering, for suspending over stacks during the time of their being built to protect them from rain. A simple implement of this sort has long been in use in Kent; but it has been improved on by Sir Joseph Banks, so as to become more manageable, though somewhat more costly. It consists of two long upright poles fixed into two cart wheels: a rope, managed by blocks and tackle, connects the poles at top, and supports, raises, or lowers the canvass roof in the usual manner of managing tents and sails. Its construction and use will be afterwards more particularly described.

2751. *The straw-yard* is a term applied to enclosures in or about the farm-yard, in which cattle are turned in loose to eat straw. In most cases this enclosure occupies the centre of the farm-yard, and includes the dung-bason, or it is a subdivision of the yard; but in some cases enclosures and sheds are erected exterior to the farm-yard, and near the straw and root-house. The great object in arranging straw-yards of this description, is to provide a sufficient extent of sheds open to the south for cover to the cattle in severe weather, and high fences or sheds on the east or west sides according to their position, relatively to the main yard, for shelter.

2752. *The poultry-yard* in most cases may be a very small enclosure, as the poultry of common farmeries should be allowed to range over the straw-yards and most parts of the premises, to pick up what cannot be got at by swine.

2753. *A tradesman's-yard* or small enclosure is often appended to the smith's and carpenter's shops, as well to contain timber as implements in want of repair, &c.

2754. *A kitchen-garden* is an essential appendage to the dwelling-house. Its situation should be apart from the farmery, so as not to interfere with it, or be injured by the blowing in of straws, &c. The size of the garden will, of course, depend somewhat on that of the house and farm; but as a small farmer with a large family will require as many or more vegetables than one of a higher class, there can be no impropriety in the garden being large. As potatoes and turnips, and sometimes other vegetables, may be had of better quality from the field, some abatement of size may be allowed on this account. In general, the garden need not be under a fourth, nor exceed half an acre. The best fence is a wall, and next a close oak paling; but if neither of these can be had, a thorn hedge will answer, though its roots always rob a portion of the accompanying border, and it harbours vermin. The best form is a parallelogram, lying east and west,

which may be intersected by walks, so as to divide it into four or six other parallelograms, with a surrounding border as broad as the enclosure fence is high.

2755. *An orchard* may either be regularly formed on an allotted space ; or fruit trees may be scattered over a lawn or piece of grass ground which may surround the house. In a convenient part of this orchard, posts should be fixed as a drying ground, unless that operation is performed by heated air or steam in the house.

2756. *The gardens appended to the laborer's cottages* may contain from one-eighth to one-sixth of an acre. Their situation should always adjoin the house, but whether they should surround it or enclose it on one or more sides, must depend on the position of the cow-house belonging to each cottage. In some cases, and perhaps it is the best plan, these cow-houses form a range by themselves in a small field devoted to their use, and placed behind the row of cottages.

#### SECT. VI. *Of the Union of the different Farm Buildings and Enclosures in a Farmery.*

2757. *In fixing the arrangement of a set of farm buildings*, the first thing, according to Beaton, to be taken into consideration, after choosing the situation, is the nature and produce of the farm. From these may be judged the different kinds of accommodation that will be necessary. For example, every farm must have, first, a dwelling-house ; secondly, a barn suitable to the extent of arable land in the farm, either with or without a threshing mill, but always with one, if possible ; and it should be endeavored to place it so that it may go by water, if a supply can be had ; thirdly, stables, the dimensions of which must be determined according to the number of horses necessary for the farm ; fourthly, cow-houses, or feeding-houses, or both, according to the number of cows and cattle, and so on, till the whole accommodations, and their dimensions, are fixed upon. Having ascertained these, and the situation for building on being also settled, the ground must be carefully and attentively viewed ; and if not very even, the different levels must be observed, and the best way of conducting all the necessary drains, and carrying off all superfluous moisture. Also the best situation for dung and urine-pits, or reservoirs, which will, in a great degree, ascertain at once where the cattle-houses and stables should be. These being fixed on, the barn should be as near them as possible, for the convenience of carrying straw to the cattle ; and the barn-yard should be contiguous to the barn. These main points being determined on, the others will easily be found ; always observing this rule, to consider what is the nature of the work to be done about each office, and then the easiest and least laborious way to perform that work, so far as it is connected with other offices. In case this should not be sufficiently explicit, suppose, by way of illustration, the situation of a feeding-house is to be considered of. The nature of the work to be performed here is, bringing food and litter to the cattle, and taking away their dung. The place from whence the greatest part perhaps of their food and all their litter comes, is the barn ; therefore the feeding-house should be as near the barn as possible. If turnips or other roots, or cabbages, make a part of their food, the most commodious way of giving these must be determined on ; whether by having a root-house adjoining the cattle-house, and that filled occasionally, or by having a place to lay them down in, near the heads of the stall, from whence they are thrown in at holes left in the walls for that purpose. The easiest method of clearing away the dung must also be considered, and the distance from the main dung-pit and urine reservoir. The same general rule being observed in determining on the site of all the other offices or accommodations, together with a careful examination of the ground to be occupied (upon which the arrangement of the offices in a great measure should depend), any person conversant in rural affairs, who attends to these particulars, and can lay down his ideas in a drawing, may easily direct the planning and building of a very commodious set of offices. With respect to the site of the dwelling-house, it may be remarked, that, although a house being situate in the middle of a regular front, is in some points of view the most pleasing way, and in many situations perhaps the best, yet, unless the ground and other circumstances in every respect favor such a disposition, it should not invariably be adhered to ; for it may often happen, that a much better situation for the dwelling-house may be obtained at a little distance from the offices, a pleasing uniformity be observed in them at the same time, and the house be more healthy and agreeable. In some cases, and for some kinds of farms, it may be particularly necessary to have the house so placed, in respect to the offices and farm-yard, as to admit of their being constantly inspected, and the labor that is to be performed in them attended to and overlooked.

2758. *The particular requisites of a farmstead*, Marshall observes, "are as various as the intentions of farms. A sheep-farm, a grazing-farm, a hay-farm, a dairy-farm, and one under mixed cultivation, may require different situations, and different arrangements of yards and buildings. On a farm of the last species, which may be considered

as the ordinary farm of this kingdom, the principal requisites are, shelter, water, an area or site sufficiently flat for yards and buildings; with meadow land below it, to receive the washings of the yards; as well as sound pasture-grounds above it for a grass-yard and paddocks; with private roads nearly on a level, to the principal arable lands; and with suitable outlets to the nearest or best markets." The first of which when wanting, in the desired situation, may in time be supplied by plantations and mound-fences. And where there is not a natural supply of water, a well, water-cellar, or artificial rill may, he says, furnish it.

2759. For a farm under mixed husbandry, the particulars, to be arranged according to Marshall, may be thus enumerated; namely, 1. A suit of buildings, adapted to the intended plan of management,—as a dwelling-house, barns, stables, cattle-sheds, cart-shed. 2. A spacious yard, common to the buildings, and containing a receptacle of stall-manure, whether arising from stables, cattle-sheds, hog-styes, or other buildings; together with separate folds, or straw-yards, furnished with appropriate sheds, for particular stock, in places where such are required. 3. A reservoir, or catchpool, situated on the lower side of the buildings and yards, to receive their washings, and collect them in a body for the purpose of irrigating the lands below them. 4. A corn-yard, convenient to the barns; and a hay-yard contiguous to the cow or fatting-sheds. 5. A garden and fruit-ground near the house. 6. A spacious grass-yard or green, embracing the whole or principal part of the conveniences; as an occasional receptacle for stock of every kind; as a common pasture for swine, and a range for poultry; as a security to the fields from stock straying out of the inner yards; and as an ante-field or lobby, out of which the home-grounds and driftways may be conveniently entered. In respect to the distribution or management of these different objects, he remarks, that in order to make it with good effect, great caution, study, and patience are required, that the most may be made of given circumstances. "An accurate delineation of the site which is fixed on, requires," says he, "to be drawn out on a scale; the plannist studying the subject, alternately, upon the paper, and on the ground to be laid out; continuing to sketch and correct his plan, until he has not a doubt left upon his mind; and then to mark out the whole upon the ground, in a conspicuous and permanent manner, before the foundation of any particular building be attempted to be laid. It may," he thinks, "be naturally conceived by a person who has not turned his attention to this subject, that there must be some simple, obvious, and fixed plan to proceed upon. But seeing the endless variety in the mere dwelling-places of men, it is not to be wondered at, if a still greater variety of plans should take place where so many appurtenances are required, and these on sites so infinitely various; nor that men's opinions and practices should differ so much on the subject, that on a given site, no two practical men, it is more than probable, would make the same arrangement." There are, however, he says, "certain principles which no artist ought to lose sight of in laying out" such buildings and conveniences. "The barns, the stables, and the granary, should be under the eye, — should be readily seen from the dwelling-house." And "the prevailing idea, at present, is, that the several buildings ought to form a regular figure, and enclose an area or farm-yard, either as a fold for loose cattle, or, where the stalling of cattle is practised, as a receptacle for dung, and the most prevailing figure is the square. But this form is, he thinks, more defective than the oval or circle, the angles being too sharp, and the corners too deep. Besides, the roadway, necessary to be carried round a farm-yard in order to have a free and easy passage between the different buildings, is inconveniently lengthened or made at greater expense. The view of the whole yard and buildings from the house on one side of it, is likewise more confined." He had formerly suggested the plan of a polygon, or many-sided figure, or an irregular semi-octagon, with the dwelling-house and stables on the largest side, having ranges of cattle-stalls opposite. But has since formed one on the complete octagon (*fig. 373.*), the dwelling-house (*a*) being on one side, and the entrance gateway and granary opposite, the remaining six sides being occupied by stables and cattle-sheds (*c, d*), and other out-buildings (*e*), a barn and threshing machine (*f*), with a broad-way (*g*), dipping gently from the buildings, and surrounding a wide shallow dung-bason (*h*), which occupy the rest of the area of the yard.

Externally is a bason (*i*), for the drainings of the yard; and grass enclosures for calves, poultry, and fruit-trees, and rick-yard. This is given as a hint to those engaged in lay-

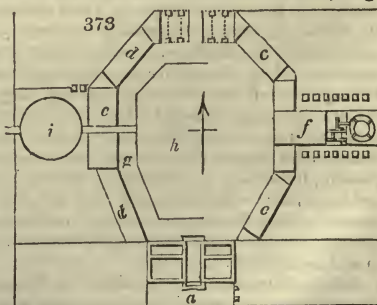

ing out and directing buildings of this sort, which they may adapt to the particular nature of the site or situation of such erections.

2760. An example of the arrangement of a small farm-house and offices (fig. 374.), is given by Beaton, which he considers as very convenient. At the north-west corner is the barn (a), with a water threshing-mill; a straw-house (b); being a continuation of the barn above, for holding a quantity of straw after it is threshed, or hay, that it may be at hand to give to the cattle in the feeding-house below.

The upper part of this straw-house may consist of pillars to support the roof, with about eight feet space between them, whereby a good deal of building will be saved. In the floor should be hatches, at convenient distances, to put down the straw to the cattle below. A court for the dung-hill (c) has a door to it from the feeding-house, and a large entry at the other end to admit carts to take away the dung; on the outside of this should be a urine-pit, in the most convenient place, according to the form of the ground; a cow-house (d), has a door also to the dung-court; and a calf-pen (e), with a rail across to keep in the calves, even though the doors are all open, adjoins; there is a stable, with a harness-room, and a place for keeping corn (f); a root-house (g), over which, or over the barn, may be a granary; a shed for carts (h); a place for keeping large implements, as ploughs and harrows (i); for keeping smaller implements, as

spades, shovels, rakes, forks, &c. and for laying by old iron and many other useful things that might otherwise be lost or thrown away (k); a pond for washing the horses' feet (l); which slopes down from each extremity towards the middle, where it is deepest, that the horses may easily go in at one end, and come out at the other, with a rail at each end, to prevent them going in during frost, or when not wanted to go; a pump, with a trough for the horses or cattle to drink in, especially while other water is frozen, or when the water in the pond is dirty (m); but if it can be contrived so that the water which drives the mill may run through this pond, it will be preferable as being at all times clean and wholesome. One material advantage of this arrangement, Beaton remarks, is, that the fodder consumed upon the farm goes progressively forward from the barn-yard through the cattle houses to the dung-hill, without the

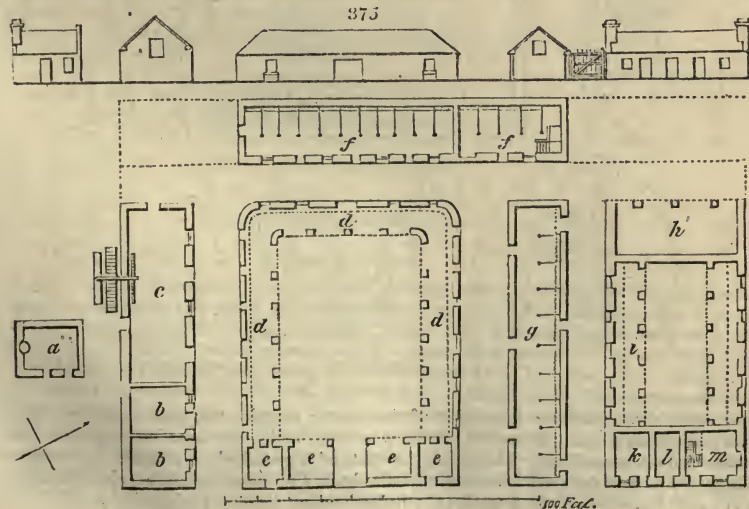
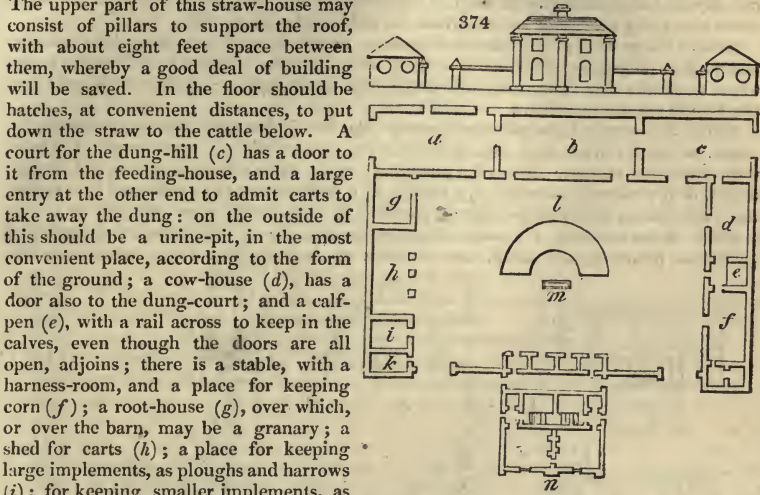

100 Feet.

unnecessary labor generally occasioned by carrying it backwards and forwards; for it comes from the barn-yard into the barn, where it is threshed. It is then put in the straw-house, and given to the cattle immediately below; and after passing through them, it is thrown into the dung-court. A rick of straw, or hay, built behind the stable or cow-house, or in a shed contiguous to either, with proper conveniences, will have the same progressive course to the dung-hill; for, it will be observed, the communication from these is equally easy from without or within; the rail across the calpen being intended chiefly to keep in the calves, while the doors on each side are open when conveying the dung that way from the stable to the dung-hill.

2761. *The ground plan of the dwelling-house to this farmery (n), has a dairy, pantry, and various conveniences behind for keeping swine, poultry, coals, &c.* The stair to the upper chambers rises from either side to the same landing-place; from whence are a few steps up to the chamber-floor.

2762. *A convenient Berwickshire farmery (fig. 375.), has the following accommodations: a smith's work-shop detached from the court-yard (a); straw-rooms (b); barn with threshing machine driven by water (c); cattle sheds (d); root-rooms and implements, or if preferred, hammels (e); stable (f); fattening cattle (g); cart-shed (h); cattle-sheds for feeding (i); riding-horse (k); tools (l); single men's room or bailiff (m).*

2763. *As an example of a commodious arrangement for an arable farm managed for a gentleman farmer by his bailiff, both resident at the farm (fig. 376.), we give the fol-*

376

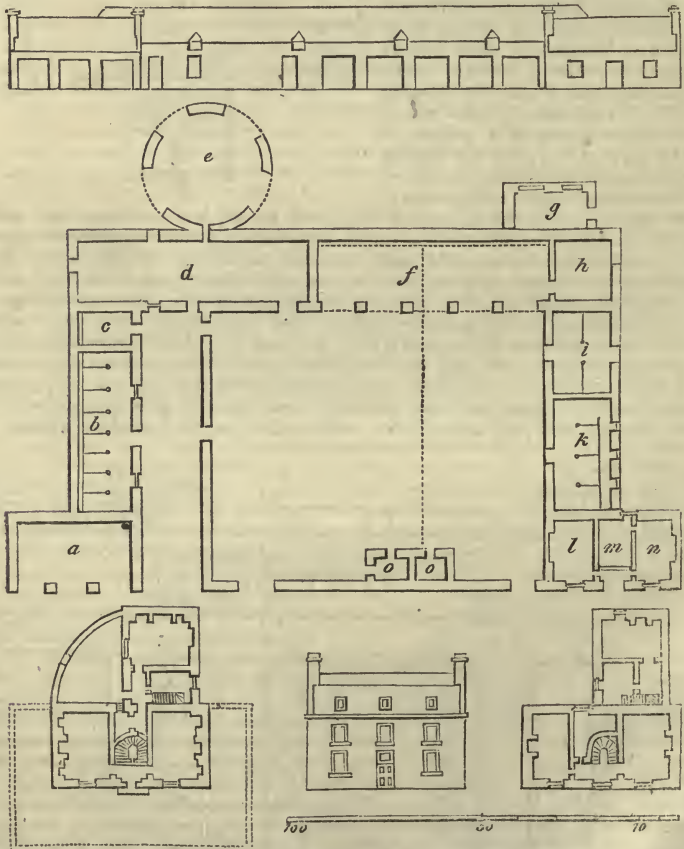

lowing details. The dwelling-house of the master contains two good sitting-rooms on the parlor floor; three bed-rooms on the first floor, and attics over them, and over the cellar two kitchen offices. The farmery consists of a cart-shed (a); stable (b); riding-horse (c); barn (d); mill-shed (e); cattle-shed (f); steaming place (g); root-house (h); cow-house (i); fattening cattle (k); bailiff's house (l, m, n); piggeries (o).



2764. As an elegant and commodious design we give the following from the *General Report of the Agricultural State of Scotland*. The dwelling-house contains two parlors (fig. 377 a, b); kitchen (c); dairy (d); pantry (e); dining parlor (f); bed-rooms (g, h); cellars (i). The farmery consists of cart-sheds and granary over (a); riding horse stable (b); common stable (c); stalled cattle (d); places for tools and other articles of the cattle attendant (e); entrance from the spacious root or turnip shed (f); straw (g); threshing-machine and water-wheel (h); granaries and straw-lofts over (g, l, m); tools and sundries (i); smith's shop (j), and carpenter (k).

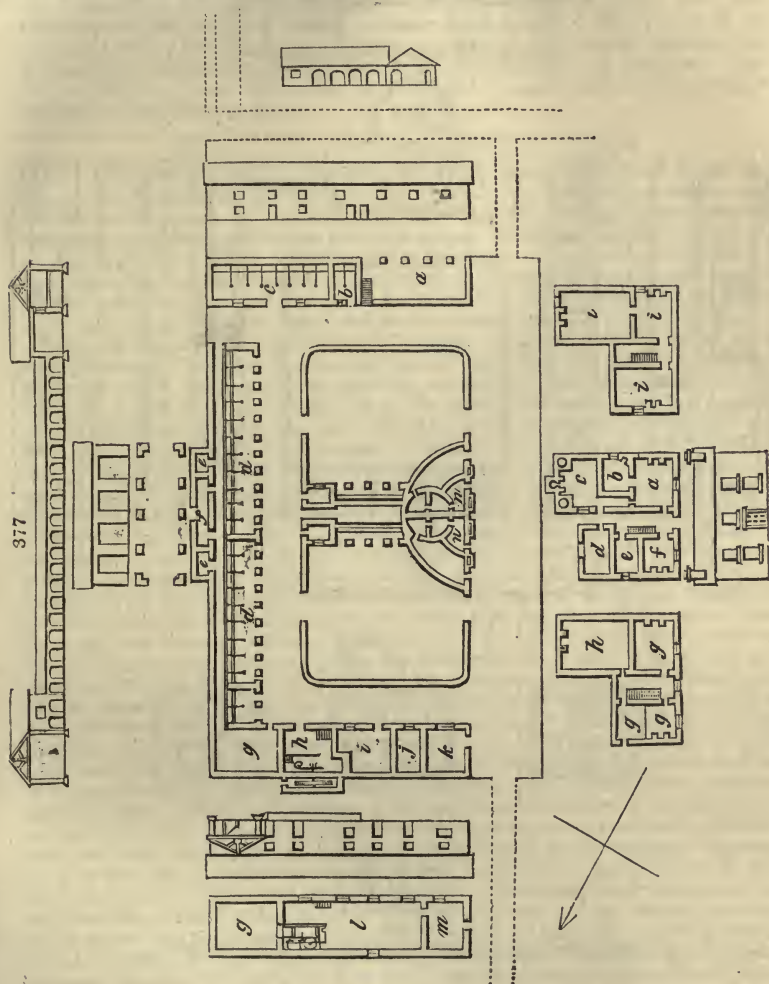

2765. As an example of a very complete farmery, with a threshing-machine, driven by steam, to be formed by a bailiff for the proprietor, we give that of the Dayhouse in Staffordshire (fig. 378.). The lands contain nearly 500 acres of mixed soil, and the buildings, besides the bailiff's house, which consists of a parlor (a); family room (b); brew-house (c); kitchen (d); pantry (e); milk-house (f); bed-rooms (g); attics (h).

2766. The farmery contains the following accommodations. Men servants' day-rooms (a); sleeping ditto, above (b); hackney stable (c); shed for implements (d); cart-horse stables (e); hay-loft (f); tool-house (g); barn and steam-engine (h); feeding and cow-tyings (i); turnip-house (j); great granary and hay-room (k); this room is used for the annual agricultural dinner given by Lord Stafford. Small granary (l); corn-loft (m); straw-lofts (n, o); pig-styes, and hen-houses over (p).

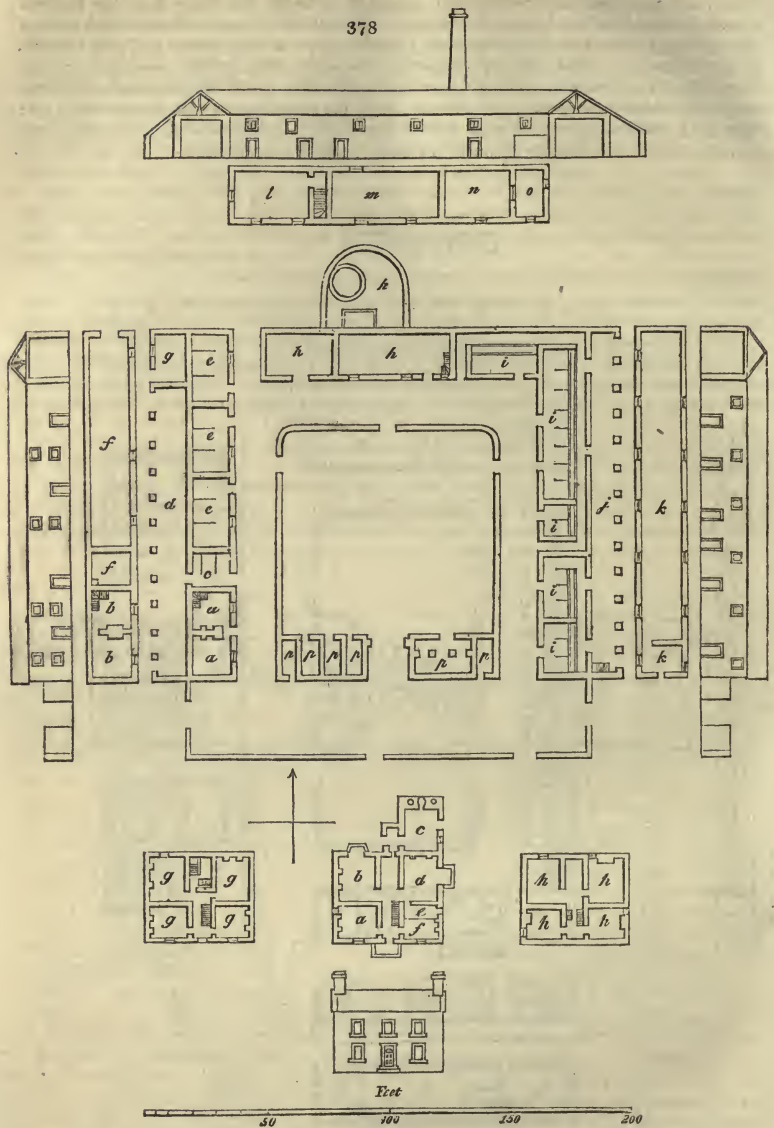

#### CHAP. IV.

##### *Of the Fences used in Agriculture.*

2767. *Fences*, next to implements, machinery, and suitable buildings, are in most situations "indispensable to the profitable management of arable land. They are not only necessary to protect the crops from the live stock of the farm, but often contribute, in no small degree, by the shelter they afford, to augment and improve the produce itself. On all arable farms, on which cattle and sheep are pastured, the ease, security, and comfort, which good fences give, both to the owner and the animals themselves, are

too evident to require particular notice. And as there are few tracts so rich as to admit of crops being carried off the land for a succession of years, without the intervention of green crops consumed where they grow, fences, of some description or other, can very rarely be dispensed with, even in the most fertile and highly improved districts." The same able author complains of the general mismanagement of this branch of husbandry, by which means fences not only often become comparatively useless, but even injurious by the space they occupy, and the weeds they shelter. This, he says, "is particularly the case with thorn hedges, which are too often planted in soils where they can never, by any management, be expected to become a sufficient fence; and which, even when planted on suitable soils, are in many cases so much neglected when young, as ever afterwards to be a nuisance, instead of being an ornamental, permanent, and impenetrable barrier, as with proper training, they might have formed in a few years. (*Sup. Encyc. Brit. art. Ag.*) Fences may be considered in regard to their emplacement or situation, and their form or kind.

#### SECT. I. *Of the Situation or Emplacement of Fences.*

2768. *The emplacement or disposition of fences on a farm or an estate, will depend on the purposes for which they are made. In laying out an estate, their disposition will depend on the natural surface and situation of roads; water-courses; on the lands to be planted with trees, and on a variety of other considerations which will come under review in the succeeding part of this work. The situation of fences on a farm depends on a great variety of circumstances, as the extent of the farm; its climate, whether pasture, or arable, or mixed; on the inequalities of the surface; on the nature of the soil; on the supply of water, and on the course of husbandry to be followed.*

2769. In determining the *subdivisions of an arable farm*, the excellent author above quoted observes, "whatever may be the kind of fence which it is thought advisable to adopt, we would recommend that particular attention be paid to the course of crops which the quality of the soil points out as the most advantageous; and that upon all farms, not below a medium size, there should be twice the number of enclosures that there are divisions or breaks in the course. Thus, if a six years' rotation be thought the most profitable, there should be twelve enclosures, two of which are always under the same crop. One very obvious advantage in this arrangement is, that it tends greatly to equalize labor, and, with a little attention, may contribute much to equalize the produce also. On large farms, where all the land under turnips and clover, for instance, is near the extremity of the grounds, or at a considerable distance from the buildings, supposed to be set down near the centre, it is clear, that the labor of supplying the house and straw-yard stock with these crops, as well as the carriage of the manure to the field, is much greater than if the fields were so arranged, as that the half of each of these crops had been nearer the offices. But by means of two fields for each crop in the rotation, it is quite easy to connect together one field near the houses, with another at a distance, and thus to have a supply at hand for the home stock, while the distant crops may be consumed on the ground. The same equalization of labor must be perceived in the cultivation of the corn-fields, and in harvesting the crops. The time lost in travelling to some of the fields, when working by the plough, is of itself a matter of some consequence on large farms. But the advantages of this arrangement are not confined to the equalization and economy of labor; it may also, in a great measure, render the annual produce uniform and equable, notwithstanding a considerable diversity in the quality of the soil. A field of an inferior soil may be connected with one that is naturally rich, and in the consumption of the green crops, as well as in the allowance of manure, the poor land may be gradually brought nearer, in the quantity and quality of its produce, to the rich, without any injury to the latter. Thus a field under turnips may be so fertile, that it would be destructive to the succeeding corn crops to consume the whole or the greater part on the ground; while another may be naturally so poor, or so deficient in tenacity, as to make it inexpedient to spare any part for consumption elsewhere. By connecting these two under the same crop, — by carrying from the one what turnips are wanted for the feeding-houses and straw-yards, and eating the whole crop of the other on the ground with sheep, the ensuing crop of corn will not be so luxuriant on the former as to be unproductive, while the latter will seldom fail to yield abundantly. The same plan will also be advantageous in the case of other crops. Hay or green clover may be taken from the richer field, and the poorer one depastured; and on the one wheat may succeed both turnips and clover, while the more gentle crops of barley and oats are appropriated to the less fertile field. These observations are particularly applicable to turnip soils, of such a quality as not to require more than one year's pasturage, and which are therefore cultivated with corn and green crops alternately; but the same principle may be extended to clay lands, and such as require to be depastured two or more years in succession.

2770. *Where hedges are employed as fences*, it is of importance that the ditches be drawn in such a direction as to serve the purposes of drains, and also that they may receive the water from the covered drains that may be required in the fields contiguous. According as the line of the fence is more or less convenient in this respect, the expense of draining may be considerably diminished or increased.

### SECT. II. *Of the different Kinds of Fences.*

2771. *Fences in regard to kind*, may be arranged as live fences, dead fences, and mixed kinds; but there are four elementary species which are the foundation of all the others; the hedge, the ditch, the wall, and the paling. The hedge, when formed of the white or black thorn, of the plum, or crab, or of the holly, is the cheapest, most durable, and the handsomest of all fences on a good deep soil: the ditch is the best on low flat wet lands requiring much drainage; the wall is the best for farming purposes in almost all cases whatever; and the paling, whether fixed or temporary (as of hurdles), is the most convenient as a nurse-fence to hedges for immediate or temporary use, and for fencing in parks and scenery, where an air of lightness and freedom are objects of approbation. From these simple or fundamental fences, a variety of compound ones may be formed, a few of which we shall proceed to enumerate.

#### SUBSECT. 1. *Ditch or Drain Fences.*

2772. *Ditch fences*, in their simple and original state, were considered rather in the light of open drains than as fences. In a variety of instances, ditches are made for this purpose only, where there is no intention whatever to enclose the field. They are, however, sometimes meant as a fence, but, in such cases, they are made very deep and wide; and the earth taken out of them is sometimes formed into a bank, the height of which, when added to the depth of the ditch, forms a tolerable barrier. In general, however, the greatest value of the ditch is met with when it is used in conjunction with other fences.

2773. *The form of ditches* is various; some of them being of a uniform width both at top and bottom; others are wide above, and have a gradual slope downwards; a third kind have one side sloping and the other perpendicular. For whatever purpose the ditch is meant, the sloping form is by much the best; as it not only costs less money in the digging, but is at the same time much more durable, and has a neater appearance. Where open ditches are indispensably necessary for the drainage of the field, the sloping ditch is preferable to every other; as the sides are not liable to tumble in or be undermined, or excavated by the current of the water, when properly executed. The slope should be considerable; perhaps not less than three times the width at top that it is at bottom.

2774. *The open ditch, with a wall or perpendicular sides*, is liable to much objection, both in its simple and compound state: in its simple state the sides are perpetually tumbling in, especially after frosts or heavy rains, and if the field round which these ditches are made has any considerable declivity, the bottom is undermined, and large masses tumble down, bringing the hedge along with them.

2775. *The simple ditch, with a bank of earth*, consists merely of a ditch sloping gradually towards the bottom; the earth taken out of it being formed into a bank on one side, leaving a scarcement, or projecting space, of six or eight inches, on the side where the bank is formed, to prevent the earth from tumbling in and filling up the ditch.

2776. *The double ditch, with a bank between*, (fig. 379.) is not often used, unless in cases where it is meant either to plant hedges or trees on the bank between the ditches. Considered as a fence, either with or without a hedge, it has an advantage over the single ditch, as the earth taken out of the two ditches, when properly laid up, will form a bank of a somewhat formidable appearance, and which cattle will not very readily attempt to break over. For the purposes of open drainage, it is well adapted, especially by the sides of highways, where the lands have a considerable declivity towards the road; the ditch next the field, by receiving the water on that side, prevents it from overflowing and washing the road, a circumstance which very frequently happens in such situations; while the ditch on the side next the road, by receiving and carrying off the moisture that falls upon, and which would otherwise lodge there and destroy it, keeps it constantly dry and in good repair. Where double ditches are made in the immediate vicinity of high grounds, or on the sides of highways, care should be taken to prevent the water from the furrows, or side-drains, from running into the main ditch at right angles. Where this is neglected, much trouble and inconvenience arises; as when the water comes from the height, during heavy rains in a straight line into the ditch, it presses with accelerated force against the sides of it; and if the soil is of a loose incoherent nature, the bank will be undermined and washed away in many places. To prevent this, nothing more is requisite than to alter the direction of the furrows, or small side-ditches, a few yards from their opening into the main ditch.

2777. *The bank of earth, with an upright facing of turves, and a slope behind*, is a very common sort of fence, and in some situations extremely useful; in making folds, for instance, for the confinement of sheep or cattle. It is also valuable on the sides of highways, for defending the adjoining grounds, and for laying off clumps or belts of planting in the middle or corners of arable fields, for enclosing stack-yards, cottages, gardens, &c. The front of the bank is made of a very steep slope, with the turf pared off from the surface of the sloping ditch, and the mound at the back with the earth taken out of it.

2778. *The ha-ha, or sunk fence*, is calculated chiefly for fields that require no shelter, and where an uniform unbroken prospect is an object, as is the case in gardens and extensive lawns: but in all situations where shelter is wanted, the sunk-fence ought to be avoided, unless a hedge is planted upon the top of it. Sometimes a medium between the sunk and raised fence (fig. 380.) is adopted, which makes both a durable and unobtrusive barrier.

2779. *The double ditch and hedge* is now general in many parts of Britain, especially upon what are termed cold lands; from an idea, that a single row of plants would not



grow sufficiently strong or thick to form a proper fence. The advocates for this fence farther allege, that in addition to the two rows of plants forming a more sufficient fence, an opportunity is afforded of planting a row or rows of trees on the middle of the bank.



(fig. 381.). This fence is liable to many objections: the expense of forming the ditches, the hedge-plants made use of, and the ground occupied thereby, being double of what is requisite in a single ditch and hedge. From twelve to eighteen or twenty feet is the least that is required for a double ditch and hedge: this space, in the circumference of a large field, is so considerable, that upon a farm of 500 acres, divided into fifteen enclosures, the fences alone would occupy above forty acres. By throwing up a bank in the middle, the whole of the nourishment, not only of both hedges, but also of the row of trees, is confined solely to that space, which, from its being insulated by the ditches, and elevated so much above the common surface, not only curtails the nourishment of the hedges and row of trees, but exposes them to all the injuries arising from drought, frost, &c. The idea of two rows of plants making a better fence than one is certainly no good reason for such an unnecessary waste of land and money; as, in almost every instance, where the plants are properly adapted to the soil and climate, one row will be found quite sufficient; but, if it should be preferred to have two rows, the purpose will be answered equally well with a single ditch, or even without a ditch at all.

SUBSECT. 2. *Of Hedge-Fences.*

2780. *Hedge-fences* are of two kinds; either such as are made up of dead materials, or such as are formed of living plants of some sort or other.

2781. *Dead hedges* (fig. 382.) are made with the prunings of trees, or the tops of old thorn or other hedges that have been cut down; and are principally intended for temporary purposes, such as the protection of young hedges till they have acquired a sufficient degree of strength to render them fencible without any other assistance. For this purpose the dead hedge is well adapted, and lasts so long



as to enable the live fence to grow up and complete the enclosure. In many cases, however, dead hedges are had recourse to as the sole fence, and where there is no intention of planting quicks, or any other hedge. From their very perishable nature, however, they are found to be exceedingly expensive; so much so, indeed, that, after the first or second year, they cannot be kept in repair at a less expense than from a fifth to a tenth part of the value of the land, and sometimes more. When dead hedges are meant for the protection of young live fences, if the quick fence is planted upon the common surface, the dead hedge is made in a trench or furrow immediately behind it, in such a way as to prevent the sheep or cattle grazing in the enclosed field from injuring it. Where the quick fence, however, is planted upon the side of a ditch, the dead hedge is for the most part made on the top of the mound formed by the earth taken out of the ditch: these are called plain dead hedges, being made by cutting the thorns or brush-wood, of which they consist, into certain lengths, and putting them into the earth. We call them plain, in opposition to other descriptions of dead hedges where more art is used: such as the dead hedge with upright stakes wattled, and the common plaited hedge bound together at the top with willows.

2782. *In respect to live hedges* they are made either entirely with one kind of plants, or a mixture of different kinds; and for that purpose almost every tree or shrub known in Britain is either wholly or in part employed. The success of every attempt made to rear good fences will be found ultimately to depend on the plants being suited to the soil and climate, the preparation of the soil, the time and mode of planting, the age of the plants, their size, the dressing or pruning of the tops and roots before planting, weeding, hoeing, pruning, and after-management.

2783. *The proper choice of hedge plants* is of the first importance. Many failures in this part of the business might be enumerated; especially in the more elevated situations, where great labor and expense have been employed to raise hedges of hawthorn, which, after many years' care and attention, were found totally unfit for such inclement regions. In such situations, experience has now sufficiently proved, that good fences can be reared in a short time with beech, birch, larch, and the Huntingdon willow: hedges of these kinds ought, therefore, to be the only ones used in hilly countries, or upon cold wet soils; the three first upon the dry soils, and the last, with the addition of poplars, upon such as are wet or marshy. In the low country, however, and in the less elevated parts of the uplands, the white thorn will be found the best upon all the dry, or moderately dry, parts of the soil; especially the different kinds of loamy, sandy, or gravelly lands: upon clays, or cold wet soils, however, beech, crab, birch, poplar, willow, and alder, may be used with advantage. The birch, poplar, alder, and Huntingdon willow, are peculiarly calculated for the coldest, wettest, and most marshy parts; while beech, crab, &c. will be found to answer best upon the stiff clays. Hazel, sweet-briar, mountain-ash, and indeed all the different kinds of forest-trees that are at present known to

delight in dry soils, may also be successfully employed for making hedges in the low lands; but whichever of these is used, they should, if possible, be without mixture. It is seldom that any soil, however good, will be found equally favorable to the growth of plants opposite in their natures; this circumstance alone will render their growth unequal, and of course make the fence faulty and defective. These defects in the fence, and inequalities in the growth of the plants, will increase with time, become every day more apparent, and be every day more sensibly felt; as the plants which have thus acquired the ascendancy will continue to keep it, and not only shade the weaker ones, and prevent them from enjoying the influence of the sun and air, but also deprive them of nourishment. Independent of these considerations, there is another, it is observed, of equal, perhaps greater, moment, that requires to be mentioned; allowing the soil to be equally favorable to the growth of the whole plants of which the mixture consists, there are certain plants which are highly inimical to the growth of others, when planted in their immediate vicinity; ivy and honeysuckle, for instance, when mixed with thorns, or other plants in a hedge, never fail to destroy such of the hedge-plants as they fasten upon; indeed moss, which is known to be one of the worst enemies to all hedges, is not more dangerous or more certainly ruinous; even the different kinds of sweet-briar, virgin's bower, brambles, briony, cleavers, &c. have the same effect; and in the end never fail to produce a gap in that part of the edge where they grow, by smothering the other plants.

2784. *The preparation of the soil for hedges*, is one of those points intimately connected with, and, indeed, essential to, their success. Except in a very few instances, however poor the soil may be; or however strong the cohesion of its parts, no attempt is made either to break that cohesion by tillage, or improve its quality by enriching or alterative manures: the young plants being for the most part laid upon the old surface, which has perhaps never been opened by the labor of man, and their roots covered with the earth taken out of the ditch, consisting very often of the poorest and coldest *till*, or of earths loaded with iron or other metallic impregnations. To those who have considered the matter with the smallest attention, the fate of such a hedge will not appear doubtful; the surface upon which the plants are laid will be so hard and impervious to the roots, as to preclude the possibility of their penetrating it; of course, their only chance of either extending themselves, or procuring nourishment, is by spreading out between the surface and the mound made by the earth taken out of the ditch, or by striking up into the mound, where, though the soil will be sufficiently open to admit of this, the roots, in place of finding an establishment in a situation friendly to their growth, will very often be either starved or poisoned.

2785. With respect to the *age at which hedge-plants ought to be used*, it is very common, especially where young hedges are made with thorns, to plant them of one, two, or three years old, seldom exceeding this last age. Plants of this description, when put into the earth at a proper season of the year, upon land that is well prepared, and that are afterwards carefully kept clean, and the earth soft and loose, by regular weeding and digging, seldom fail to make good fences; such young plants, however, are, it is observed, long in a state of infancy, and require great nursing and the most complete protection to bring them to perfection, and are liable to be either much hurt or totally destroyed by many accidents that would produce little or no effect upon older and stronger plants. Much time might be saved in the rearing of hedges, and the fences be much more perfect and useful, if older plants were employed for that purpose. Three years old is certainly the youngest that should be planted, and if they are even six or seven years old, so much the better: the prevailing idea that plants of that age will not thrive if transplanted, is totally unfounded. Thorns of six or seven years old, in place of being no thicker than a common straw, will be at a medium more than an inch in circumference: we leave those who are judges to determine how far a plant of this last description will be superior to one of two years old, and how much sooner it will answer the purposes of a fence.

2786. *In respect to the size of thorns or other hedge-plants*, it may be necessary to observe, that, when the plants are once obtained, they should be separated into sorts, according to their size and apparent strength, picking out the largest first, and so on downwards. This will be attended with several very material advantages, which those who have made observations on the subject will very readily understand; plants of the same size and strength, when planted together, keep pace with each other; no one of them takes from the earth more than its own share of nourishment, of course the growth of the whole is regular and uniform; and the hedge, when arrived at a certain age, becomes a substantial efficient fence, of an equal height throughout, and free of any gaps: whereas, when no pains have been taken in assorting the plants, and they are planted promiscuously, great and small, strong and weak, the consequence is, that the strongest plants very soon outgrow such as are weaker, and not only overtop them, but also deprive them of that nourishment which they so much require: as the hedge advances in age, the evil becomes greater, small stunted plants and innumerable gaps appearing throughout the whole line of the fence; interspersed with others remarkable for their strength and luxuriance.

2787. *This assorting of hedge-plants* has a farther advantage; namely, that of putting it in the power of the person who plants the hedge to put down the large, strong, healthy plants upon the poorest part of the line of the fence, and to set such as are smaller and weaker upon the richer and more fertile parts. He has it also in his power, by a more careful preparation of the soil, and bestowing a greater proportion of manure upon the spaces where the small plants are set, to give them that nourishment and assistance

which they require, and which would very soon enable them to form a fence equal to that part occupied by the strongest plants.

2788. In regard to the *dressing and pruning of hedge-plants before they are put into the earth*, there is perhaps no part of the system of managing them, or forest trees, more hurtful and defective than that now pursued in the common nurseries. It is a very common practice with nurserymen, in the spring, when they wish to clear their ground for other purposes, to take up great quantities of thorns and other hedge-plants; and after pruning the tops, and cutting off nearly the whole of the roots, to tie them up in bundles, and lay these bundles in heaps till they are called for. In that mutilated state they often remain for many weeks, with the mangled roots naked and unprotected, exposed to every inclemency of the weather, before they are sold. In place of this treatment, the defects of which are so obvious, and the consequences resulting from it so hurtful, no hedge-plants should be lifted out of the nursery-ground till the day or at least a few days before that on which they are to be replanted, and in place of the severe pruning and dressing already mentioned, every root, even to the smallest fibre, should be carefully preserved, and the use of the knife confined entirely to the necessary curtailment of the tops. Where this care is taken, and the plants are put into the ground at a proper season, they will suffer no kind of check, and when the spring arrives grow luxuriantly and with vigor.

2789. In the *after-management of the hedge*, complete weeding, loosening, and laying new earth to the roots, for the first three or four years, are indispensable requisites; for, whatever pains may have been previously taken in dunging and summer-fallowing the soil, unless it is properly attended to and kept clean afterwards, this dunging and summer-fallow, in place of being useful, will prove hurtful to the fence; as the manure and tillage, by enriching and opening the soil, will encourage and promote the growth of weeds; which, under circumstances so peculiarly fortunate, will become so luxuriant, as either to destroy or materially injure the growth of the hedge, unless they are kept down by frequent and complete cleanings. In loosening the earth about the roots of hedges, whether old or young, it will be of advantage, if there is soil enough to admit of it, to lay up a few inches of it to the roots; doing this frequently encourages them to push out branches near the bottom, which prevent them from growing thin and open, a fault to which almost all hedges are liable, if due pains are not taken to prevent it.

2790. On the *pruning and after-management of hedges* will depend a very considerable part of their beauty and future value. There is, perhaps, no part of the subject upon which a greater contrariety of opinion at present prevails, than the age at which the pruning of hedges ought to commence, the manner of that pruning, or the season of the year at which it may be given with the greatest possible advantage and the least risk; the practice with some is, to prune, from the first year, not only the lateral branches, but the tops also; they give as a reason, that cutting off the extremities of the shoots contributes to thickening of the hedge, by making them push out a great number of new ones. The fallacy of this argument, and the mischief with which the practice is attended, we shall have occasion to notice afterwards. As to the manner of pruning, or the form of the hedge, these seem, with many, to be matters of indifference, no attention being paid to dressing them in such a way as to have them broad at bottom, and tapering gradually towards the top: many of them being not only of one width from top to bottom, and not a few much heavier and broader above than they are below, it is obvious that such hedges can neither look well nor be useful.

2791. The *season at which they are trimmed* is in many instances an improper one; for in place of choosing that time when the plants are least in danger of suffering from an effusion of their juices, which is either at a late period in the autumn, very early in the spring, or about midsummer, the pruning is given late in the spring season, when the sap is flowing: the check and injury they must receive from having the whole of their extremities cut off at that period may easily be conceived. In speaking of the treatment of hedge-plants before they are put into the ground, notice has been taken of the necessity of preserving the roots as much as possible, and at the same time shortening the tops: this last operation has two good effects; by curtailment the top and branches, the roots have less to nourish; and by leaving only two or three inches of the top above ground, in place of growing up with a single stem, it sends out two or three; and as these strike out from the plant so near the earth, each of them has the same effect, and strengthens the hedge as much as the original stem would have done by itself; with this addition, that, in place of one prop or support, the hedge will have three or four.

2792. After *this first pruning*, however, no hedge should be touched, or at least very gently, for some years; from an inattention to this circumstance, and the injudicious application of the knife or shears at an early period, many young hedges are rendered useless, which, under different treatment, would have made excellent fences, with one half the trouble that was required to destroy them. The practice of cutting over the tops yearly, which is done with a view to render the hedge thicker and more perfect, is one of those mistakes which we would naturally have supposed common sense and observation would have sooner corrected; the effect produced being, in almost every instance, the very reverse of what was intended: shortening the main stem of a thorn or any other plant makes it throw out a number of small stems immediately at the place where it has been cut; and if this operation is repeated once or twice a year, every one of these is again subdivided, as it were, by sending out more branches: thus, in a course of years, during which the hedge makes very small progress upwards, if it be examined, instead of being found to consist of strong vigorous plants, with a good main trunk, each reaching from top to bottom of the hedge, and a sufficient number of lateral branches throughout the whole length of it, it will be found, by such repeated cuttings, in the same stunted situation as certain young trees and shrubs, that are frequently cropped by sheep or cattle. From the repeated crops of young shoots which the tops send

out after every clipping, and the great quantity of nourishment necessary to support such additional numbers, the lateral shoot at the bottom, upon the strength and numbers of which the value of the hedge in a great measure depends, are stunted in their growth, and soon die; the hedge, of course, becomes open and naked at the bottom, and consequently useless as a fence.

2793. *From the first year of planting, till the hedge has risen to the height of five or six feet, the main stems ought to be left untouched, and the pruning confined solely to the side branches, leaving those next the root pretty long, and gradually tapering towards the top; this pruning of the side branches will make them send out many new shoots from their extremities, which, by repeated trimmings, will become so thick as to fill up every interstice from top to bottom of the hedge; while the main stems, by being left untouched, continue their growth upward, till they arrive at the necessary height, when they may have their extremities cut off with perfect safety.* When a hedge has attained the wished for height, all that is requisite afterwards is cutting the sides regular with a hedge-bill, preserving it pretty broad at bottom, and drawing it gradually to a point at top; this form of a hedge is pleasant to the eye, is well calculated to stand the weather, and becomes every year stronger and thicker. A hedge of this sort in full leaf has the appearance of a solid wall; and, when viewed after the leaves are shed, presents to the eye a set of massy growing piles, so strong and formidable as to bid defiance to any attempts that may be made to break through them.

2794. *In the management of old hedges, the above directions and observations apply, with strict propriety only to such as have been regularly attended to from the time of their being planted; as there are, however, innumerable hedges in the kingdom, which, by being neglected, have grown up to a great height, have become open and naked below, and bushy and unmanageable at top, it is of consequence to point out the means of reducing such hedges to a moderate scale, and rendering them useful.*

2795. *This purpose can only be effected by cutting them down, and procuring from their stumps a growth of new shoots, which, with proper management, will soon make a perfect fence.* If the fields enclosed by such hedges are alternately in pasture and tillage, the period most proper for cutting them down is when the field is to be ploughed. Under a corn-crop, the confinement of the stock is no longer an object; and by the time the field is again brought under pasture, the hedge, if properly treated, will have acquired strength enough to become a good fence. This operation is performed in several different ways; in the first, the hedge is cut over, about a yard above the surface (*fig. 383.*), and is left in that state without any other pains being taken with it; if it has originally been good, and the plants thick enough at bottom, this kind of cutting will answer the purpose perfectly well, and in a few years the hedge will, with proper dressing, become both a neat and an useful fence. But in this mode, when there has been a deficiency of plants, and the hedge is cut over in the manner above mentioned, innumerable gaps will appear, which, without some art, it will be impossible to fill up. It has also this farther disadvantage, that if either horses or cattle attempt to leap into, or out of the enclosure, the sharp points of the stakes are apt to run into their bellies; this accordingly often happens, and many valuable horses and cattle are killed or greatly injured by such means.

2796. *A preferable mode of cutting down old hedges is, to cut a fourth part of the plants over, to the height which the fence is intended to be made; another fourth about six inches high, and to bend down and warp the remainder with the upright stems (*fig. 384.*). This method very effectually cures the gaps and openness below, and with slight attention soon makes a good fence.*

2797. *A third way of cutting over old hedges is that of cutting them close by the surface; this practice, when the plants are numerous, and there are no gaps in the hedge, answers very well; but when there is a deficiency of plants in any part of the hedge, the want will be very apparent. This last mode, though much inferior to the one immediately preceding, is nevertheless greatly preferable to that first described, as the young shoots sent out from the stumps, by being so near the ground, will in some measure remedy the defects occasioned by the want of original plants; whereas, when the old plants are cut at the distance of about a yard or four feet above the surface, the young shoots produced by the cutting will be so high, as to leave the hedge open at the bottom.*

2798. *The last method of cutting down old hedges, and which is yet but very little practised, is first to cut them down even with the surface, and afterwards to cover the stumps completely over, with the earth taken out of the ditch, or from the road-side. When this is carefully done, it is asserted that every single stump sends out a great number of young vigorous shoots, each of which, by branching out from below the surface, sends out roots, and acquires an establishment for itself; by that means the bottom*

383



384





of the hedge becomes so thick, that neither sheep, cattle, or indeed any animal, can break through it.

2799. *In whichever of these ways the hedge is cut down*, the directions formerly given for the management of *young hedges* should be strictly attended to, as soon as the young shoots have made some progress; the side branches should be trimmed, and the hedge put into a proper shape, preserving it broad and full at bottom, and tapering gradually towards the top. The same caution is also to be observed with regard to the upright shoots, none of which should be shortened till the hedge has attained the wished-for height. It is surprising what close beautiful fences are raised in this way in a few years, from the stumps of some overgrown useless hedges; which, at the same time with their being naked below, and of course faulty as fences, occupied four times the space they ought to have done, to the great loss both of the proprietor and farmer.

2800. In respect to *filling up gaps in hedges*, when young hedges are planted, if the plants made use of are of a nature suited to the soil, the hedge may be kept free of gaps with very little trouble; for that purpose it is, however, necessary, about the end of the first autumn after the hedge has been planted, to examine it carefully throughout its whole extent, take out such plants as are either in a decaying sickly state, or those that are actually dead, and fill up the spaces they occupied with the strongest and most vigorous ones that can be found; where this care is taken for the first two or three years, there will be no defects in the hedge, which will be uniformly thick and strong throughout. Thus far of young hedges; but when old hedges are meant to be cut down, that have many gaps or open spaces in them, so wide as to prevent the possibility of the young shoots filling them up, some expedient must be had recourse to, in order to render the fence complete. This purpose may be answered in different ways; the easiest and indeed the most common method is, for the hedger, when he comes to a place where any of the plants are wanting, to take one of the strongest plants next to it, and after giving it a gentle stroke with the hedge-bill, to bend it across the opening, and entwine it with the thorns on the opposite side; indeed, as has been already stated, some have a custom of cutting down only a fourth part of the stems, and warping the remainder with these, which appear like stakes driven into the earth. Where the hedge is shortened to within three or four feet of the ground, both of these methods answer pretty well; and the openings, which would otherwise have been left, are in some degree filled up; but when the old hedge is cut close to the earth, other methods of supplying the defects become necessary. One very simple, and at the same time very effectual mode, consists in first digging the ground pretty deep with a spade, and taking one of the strongest plants on each side of the opening that have been purposely left uncut, removing the earth from their roots so much as to loosen them, and admit of their being bent down, and laid close to the earth in the opening; they should then be fastened down with wooden hooks or pins, and entirely covered throughout the whole of their length with earth. Where this is properly executed, the plants so laid down send up a great number of young shoots, which very soon fill up the vacancy; where it is practised upon a hedge that is cut over close by the surface, no other care is requisite; but when it is done with hedges that are cut at three or four feet above it, there will be a necessity for placing a temporary paling in the gap, to protect the young shoots from injury till they acquire a sufficient degree of strength. In cases of emergency the stronger roots of thorns and crabs will, if their extremities are brought up to the surface and then cut over an inch above it, throw up vigorous shoots and fill up gaps.

2801. *To mend the defects of an old hedge* with success, two things are absolutely necessary; the first is, that the whole of the roots of the old plants, which extend themselves into the opening, be entirely cut off; the next, that the hedge shall be cut down close to the earth, for at least a yard or more on each side of it. By cutting away the roots which extend themselves into the opening, the young plants are prevented from being robbed of their nourishment; and cutting down the old ones, for a little distance on each side, keeps them from being shaded, and allows them to enjoy the full benefit of the light and air; cutting down so much of the old hedge, no doubt, renders the opening larger, and of course requires more paling to supply the defect; but this extra expense will be more than compensated by the success with which it will be attended. In many instances, these vacancies are filled up with dead wood; indeed it is a common practice, after a hedge is dressed, to cram the greatest part of the prunings into these spaces, and under the bottom of the hedge, where it is any way open or naked. The most perverse imagination could hardly suppose any thing more absurd; for, if it is the wish of the owner that the plants on each side should send out new branches to fill up the openings, the purpose is completely defeated by cramming them full of dead brush-wood, which not only excludes light and air, and prevents the extension of the branches, but, from the violence and injury that is committed in thrusting in dead thorns, the plants are often materially hurt; and when this brush-wood decays, the opening, in place of being diminished, is considerably enlarged; the mischief is the same where they are thrust

under the hedge, the practice of which, when continued, never fails to render it naked at bottom. The use of stones for mending hedges is equally absurd and pernicious.

2802. *In every operation of this kind*, where old hedges are either cut over or bent down, the ground on each side, as soon as circumstances will admit of it, should be completely dug, cleared of weeds, and the earth laid up to the roots of the plants. It is surprising what numerous and luxuriant shoots the stumps send out, when managed in this way: while, on the contrary, when these necessary operations are neglected, fewer shoots proceed from the old trunks; and, of these few, a considerable proportion are choked and destroyed by the weeds and other rubbish in the bottom of the hedge.

#### SUBJECT. 3. *Of Compound Hedge-Fences.*

2803. *The single hedge and ditch, with or without paling*, differs a little in different situations: the ditch varies in depth and width; the thorns are for the most part placed upon the common surface, upon what is termed a scarcement, or projection of six or seven inches, on which they lean, and which serves as a kind of bed, when they are cleaned. It is a practice in some parts of Norfolk, in planting hedges in this way, to coat the face of the bank and the projection with loamy earth from the bottom of the ditch, made into a puddle. This acts for a year or two like a coat of plaster, and prevents the seeds of weeds, which may be in the soil under it, from germinating. It also retains moisture; but the difficulty is to meet with a clay or loam that, when puddled and thus applied, will not crack with the summer's drought and winter's frost. Some have applied common lime plaster for the same purpose; others road stuff; and some plant in the face of a wall of stones, or bricks, or between tiles.

2804. *The hedge and bank* consists of a hedge planted upon the plain surface, with a bank or mound of earth raised behind it by way of protection.

2805. *The hedge in the face of a bank* differs from the former, principally in having the hedge in the front of the bank considerably above the common surface, in place of having it at the bottom.

2806. *The Devonshire fence* is a sort of hedge and bank, as it consists of an earthen mound, seven feet wide at bottom, five feet in height, and four feet broad at top, upon the middle of which a row of quicks is planted; and on each side, at two feet distance, a row of willow-stakes, of about an inch in diameter each, and from eighteen inches to two feet long, are stuck in, sloping a little outwards; these stakes soon take root, and form a kind of live fence for the preservation of the quicks in the middle. This fence nearly resembles the hedge on the top of a bank, and is equally expensive in the erection: the formation of the bank deprives the adjoining surface of its best soil, and the plants made use of are liable to every injury that can possibly arise from drought, frost, and the gradual decay or crumbling down of the mound. The addition of the willows to this fence is certainly a disadvantage; if the quicks require protection, dead wood is equal to every purpose that could be wished or expected; and at the same time possesses the additional advantage of requiring no nourishment, and having no foliage to shade the thorns, or other plants.

2807. *In the hedge with posts and rails*, the railings are employed for the protection of hedges, as well those that are planted upon the plain surface, as for the hedge and ditch united. The addition of a paling is, however, more immediately necessary in cases where the hedge is planted upon the plain surface, especially when the fields so enclosed are in pasture.

2808. *The hedge and dead hedge* is a fence that consists of a row of quicks or other hedge-plants, set either upon the plain surface, or in the face of a ditch or bank. The dead hedge answers a double purpose, namely, that of protecting the young plants from the injuries they may receive from cattle, or the inclemency of the weather; and at the same time forming a temporary enclosure, which lasts till the hedge is grown up.

2809. *The hedge and wall fence* is of two kinds, namely, a coarse open wall, built of loose stones, on the top of the bank formed by the earth taken out of the ditch; and when hedges are planted upon the plain surface, a thin and low wall regularly built alongside, answers the double purpose of sheltering and encouraging the growth of the plants while they are in a weak tender state, and afterwards prevents the possibility of the hedge becoming open below. Where gardens are entirely, or in part, surrounded by hedges, and in the enclosing of fields by the sides of highways, especially in the vicinity of great towns, where dogs and other destructive vermin are apt to creep into the enclosures, and annoy the stock, the low wall forms a valuable addition to the fence.

2810. *The hedge in the middle, or in the face of a wall*, is executed in the following manner:—the face of the bank is first cut down with a spade, not quite perpendicular, but nearly so; a facing of stone is then begun at the bottom, and carried up regularly, in the manner that stone-walls are generally built: when it is raised about eighteen inches, or two feet high, according to circumstances, the space between the wall and the bank is filled up with good earth, well broken and mixed with lime or compost: the

thorns are laid upon this earth in such a manner, as that at least four inches of the root and stem shall rest upon the earth, and the extremity of the top shall project beyond the wall. When the plants are thus regularly laid, the roots are covered with earth, and the building of the wall continued upwards, filling up the space between the wall and the bank gradually, as the wall advances upwards; when completed, the wall is finished with a coping of sod, or stone and lime. When the plants begin to vegetate, the young shoots appear in the face of the wall, rising in a perpendicular manner.

2811. *The hedge and ditch, with row of trees*, differs from those which have been described only in having a row of trees planted in the line of the fence along with the hedge. The advocates for this practice say, that, by planting rows of trees in the direction of the fence, the country is at once sheltered, beautified, and improved; and that the interest of the proprietor is ultimately promoted by the increasing value of the timber raised in these hedge-rows. It is also said, that such trees produce more branches for stack-wood, knees for ship-builders, and bark for the tanners; and they sell at a higher price per load than trees grown in woods and groves. Besides, close pruning hedge-row trees, to the height of twelve or fifteen feet, prevents their damaging the hedge; the shelter which they afford is favorable to the vegetation both of grass and corn; it also tends to produce an equable temperature in the climate, which is favorable both to the production of and greater perfection and beauty in animals, and of longevity to man. Though the practice of planting hedge-rows of trees is very common, though its advocates are numerous, and though these arguments are urged in its favor, yet the objections are also entitled to very serious consideration. When trees are planted in the line of a fence, if that fence is a hedge, the plants of which it consists will not only be deprived of a great part of their nourishment by the trees, but will also be greatly injured by the shade they occasion, and the drop that falls from them during wet weather: upon this point little reasoning is necessary; for, if we appeal to facts, we shall find that no good hedge is to be met with where there is a row of trees planted along with it. The mischief is not, however, confined solely to hedges; the effects are equally bad, perhaps worse, where the fence is a stone wall; for though in this case the shade or drop of the trees are hardly if at all felt, yet, when they have attained a certain height, the working and straining of the roots during high winds is such, that the foundations of the wall are shaken and destroyed; accordingly, wherever large trees are found growing near stone walls, the fence is cracked and shaken by every gale of wind, is perpetually falling into large gaps, and costs ten times the expense to keep it in repair, that would otherwise be required if no trees were near it. Admitting, however, that the trees in hedge-rows were no way prejudicial to the fence, which we have already shown is by no means the case, another argument may be successfully used against the practice. It is seldom, indeed, that trees planted in hedge-rows arrive at any great size; on the contrary, they are generally low and stunted: and while they occasion a visible loss by the mischief they do the fence, their utmost worth, when they come to be sold, will seldom be found adequate to the loss and inconvenience they have occasioned.

2812. *The hedge and ditch, or hedge and wall, with belt of planting*, in exposed situations, is strikingly useful and ornamental, while upon the low grounds it is not only unnecessary, but in some instances absolutely hurtful. For instance, in deep and broad valleys surrounded by hills, and sheltered from severe blasts, belts of planting are not only unnecessary, but even hurtful and ruinous by the ground they occupy, which could certainly be employed to greater advantage, and the original expense of inclosing and planting saved.

2813. *The hedge and ditch, or wall, with the corners planted*, is employed upon some estates instead of the belt of planting. According to some, it has a good effect upon the scenery of the country, and answers the purpose of general shelter extremely well: it is, however, greatly inferior to the belt of planting, for the purpose of sheltering particular fields: but as in every field there is a space in each angle that cannot be ploughed, by planting these spaces, which would otherwise be left waste, many valuable trees are raised with little expense, and with scarce any waste of land.

2814. *The furze fence* may be had recourse to with advantage whenever such plants are found to grow vigorously in a soil. Fences of this sort are mostly made upon mounds or banks of earth, by sowing the seed of the plant. Sometimes the bank is only sloped on one side, but at others on both; in the former case the front is perpendicular, and faced with turf or stone. From these fences being raised so considerably above the common surface, they are very liable to injury from frost and other causes in severe winters.

#### SUBJECT. 4. *Paling Fences.*

2815. *Paling fences* are only to be considered in a secondary light; for, of whatever wood they are made, however substantially they may be executed, or in whatever situation they are placed, their decay commences the instant they are erected. Where permanent

use therefore is required, palings ought never to be adopted; but for ornament in pleasure-grounds, or for the protection of young thorns, they are highly valuable. In all cases where either dead hedges or palings are used, the decay and ultimate loss of the fence is owing to that part of it which is let into the ground being rotted by the moisture. Where dead hedges are planted, it is no easy matter to provide a remedy against this evil; as the stems are so numerous, that, to give each of them a preparation that would completely defend it from the effects of moisture, would be attended with an expense equal to, if not greater than the value of the fence. Where palings, however, are used, especially the most expensive and substantial kind of them, and such as are meant both for duration and ornament, it is desirable to prepare the standards, or upright parts that are placed in the earth, in such a manner as will enable them to resist the moisture for many years. In the south of England, the post is always more bulky at the lower end than the upper, and is fixed in the ground by digging a hole, placing it therein, shovelling the soil in, and ramming it round the post till it be firmly fixed. It has been a practice for time immemorial, to *burn* or *char* that part of the standards or palings intended to be set or driven into the earth: the reason assigned for this practice was, that the fire hardened the parts thus subjected to it, and, by rendering them impervious to moisture, made them more durable than they would have been without such operation. But the best defence at present known against the effects of the weather is the bark of the tree. This covering it has from nature; and it is possessed of every requisite that is necessary, being impregnated with oil, rosin, and other matters, which secure it completely, not only against moisture, but other injuries arising from the operation of air, light, heat, &c.; of this we have strong proofs by observing what happens where the bark of any tree is destroyed, by cutting off a branch, or otherwise. If the surface laid bare by the wound is considerable, the body of the tree opposite to it begins immediately to decay, and continues to waste, unless some covering is made use of to supply the place of the bark; for that purpose nothing has yet been found so effectual as a coat either of boiled oil, or of oil-paint, which, by completely excluding both air and moisture, not only preserves the tree from rotting, but also prevents it from bleeding and wasting itself by an effusion of juices from the wound. When trees are cut down and sawn into planks, whether for palings or any other purpose, where they are afterwards to be exposed to the weather, the same thing happens that we have mentioned as taking place with the growing tree when deprived of its bark, but in a much greater degree, as the whole surface is then without a covering. To prevent this decay, the same remedy should be applied, *viz.* painting the whole of the wood, or otherwise filling the pores with oil, in such a manner as to prevent the entrance of moisture. There are now coarse oil-paints sold of all colours, so cheap as to enable persons erecting palings, or other works of wood to paint them at a small expense. Other very good remedies are to be had at a moderate price, as the pyrolignous acid from gas works, into which, if the points of the standards that are to be drove into the earth are dipped while the liquor is boiling hot, it will preserve them from the bad effects of moisture for a very long time; previous to the dipping, they should be properly sharpened, and upon no account whatever charred or burnt, as every attempt of that kind will, upon enquiry, be found to injure the texture of the wood and hasten its decay. Common tar, melted pitch, or gas liquor, may also be successfully employed for the purpose of defending the extremities of the upright parts of paling from moisture; linseed and train oils may also be used with success; the great object being to fill the pores completely with some unctuous or greasy matter, so as to prevent the admission of moisture. The posts should be completely dry before they are dipped in any of these preparations; for if they are either made of green wood, or have imbibed much moisture, or after being dipped they are exposed either to the heat of the sun, or a severe frost, the moisture will become so much expanded thereby, as to burst through, and bring off the paint or other coating; whereas, when they are made of well-seasoned wood, and are at the same time perfectly dry, and the pitch, oil, varnish, &c. boiling hot, it readily enters the pores, and, by filling them completely, prevents the access of moisture, and consequently the injurious effects produced by it.

2816. *The simple nailed paling* consists of upright posts, drove or set into the earth at certain distances, and crossed in three, four, or more places, with pieces of wood, in a horizontal direction. This paling is for the most part made of coarse sawn wood, without any dressing whatever.

2817. *The jointed horizontal paling* consists of massy square poles, drove or set into the earth at regular distances, through which mortices or openings are cut, for the reception of the extremities of the horizontal pieces which traverse them.

2818. *The upright lath paling* is made by driving or setting a number of strong piles into the earth at regular distances, and crossing these at top and bottom with horizontal pieces of equal strength; upon these last are nailed, at from six to twelve inches distance, a number of square pieces of sawn wood, of the shape and size of the laths that are used for the roofs of tiled houses. This sort of paling, when properly executed, looks very well, and, notwithstanding its apparent slightness, if well supported by props or rests at

regular intervals, lasts a long while; and where there are plantations of young firs in the neighborhood, laths may be had at a trifling expense.

2819. *The horizontal paling of young firs, or the weedings of other young trees*, may be had recourse to with advantage upon estates where there are extensive woods, or where they are surrounded with belts of thriving plants, the thinnings of such woods or belts being highly valuable for making palings, especially when the plantation consists chiefly of firs; the palings of young firs are of two kinds, either horizontal or upright. The horizontal resembles the jointed dressed paling already described, and the upright is similar to the lath paling.

2820. *The chain horizontal fence* is made by fixing a number of strong square piles into the earth at regular distances, in the direction in which the fence is to run; each of these piles has three strong staples or iron hooks drove into it on each side, one near the top, one within eighteen inches of the bottom, and one in the middle; to these staples or hooks, chains are fastened and stretched horizontally, in the same manner as the pieces of wood are in a common horizontal wooden fence. When it is meant that the fence should be laid open for any temporary purpose, hooks are drove into the posts in place of staples, and the chains hung upon them; but where this is not wanted, the staples will be found the most secure method. In some cases the upright part of this fence, in place of wooden piles, such as have been described, consists of neat pillars of mason-work or cast iron.

2821. *The rope fence* is nearly the same as the former, that is, it consists of upright posts, drove into the earth at regular distances, with holes bored through them for the ropes to pass: in general, they consist of three, and in some cases of four courses of ropes, like the chain fence. This can only be used for confining cattle or horses; for sheep they will be found quite incompetent; for stretching across rivers, or pieces of water, like the chain-fence, the ropes will be useful.

2822. *The moveable wooden fence, flake, or hurdle*. This has hitherto been principally employed in cases where sheep or cattle are fed with turnips in the field, to divide a certain portion of their food at a time; in that way hurdles are extremely useful, as the sheep or cattle, by having a given quantity of food allotted them at once, eat it clean up without any loss, which they would not do, if allowed to range at large over the whole field. There are, however, many other purposes to which hurdles may be applied with equal advantage.

385

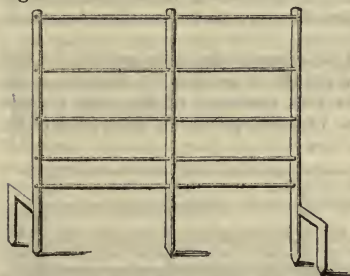

2823. *Iron hurdles (fig. 385.)* are found a very elegant and durable fence, though more than double the expense of wood. For park or lawn fences they are admirably adapted; but occupy rather too much capital for a commercial farmer to be able to spare.

2824. *The willow, or wattled fence* is made by driving a number of piles of any of the different kinds of willow or poplar, about half the thickness of a man's wrist, into the earth, in the direction of the fence, and at the distance of about eighteen inches from each other. They are then twisted, or bound together along the top,

with small twigs of the willows or poplars (fig. 386.). This kind of fence has some advantages peculiar to itself; it not only forms a cheap and neat paling; but if it is done either about the end of autumn, or early in the spring, with willows or poplars that have been recently cut down, the upright parts or stakes will take root, grow, and send out a number of lateral branches; and if pains are taken the following autumn, to twist and interweave these branches properly, a permanent fence, so close as to be almost impenetrable, may be formed in two or three years. For the enclosing of marshy lands, or for completing any enclosure, where a part of the line in which the fence ought to run is so wet as to be unfit for the growth of thorns, or the building of a wall, the willow paling will be found an excellent contrivance, and the use of it will render many enclosures complete that could not otherwise have been formed. Sometimes stakes are used of a kind which do not take root and grow, in which case this form still makes a very neat and efficient temporary fence (fig. 387.).



386

2825. *The paling of growing trees, or rails nailed to growing posts*, is made by planting beech, larch, or other trees in the direction of the fence, at a bout a yard distant from each other, more or less, as may be thought necessary; these trees should be protected by a common dead paling, till they are ten or twelve feet high, when they should be cut down to six feet, and warped or bound together with willows at top, and in the middle; the cutting off the tops will have the effect of making them push out a great number of lateral branches, which if properly warped and interwoven with the upright part of the trees, in the manner described for the willow fence, will both have a beautiful effect, and will at the same time form a fine fence, which in place of decaying, will grow stronger with time, and may with very little trouble be kept in perfect repair for a great length of time.

387



2826. *The upright and horizontal shingle fences* are chiefly made of firs, coarsely sawn into deals, of from half an inch to an inch thick, and of different breadths according to the diameter of the tree; pretty strong square piles are drove or set into the earth, and the deals nailed horizontally upon them, in such a manner that the under edge of the uppermost deal shall project or lap over the upper edge of the one immediately

below it; the fence, when finished in this manner, will have nearly the same appearance as the bottom of a boat or cutter. An upright fence is made by fixing perpendicular posts in the earth, nailing three pieces of wood horizontally, and covering these with shingles placed perpendicularly; in this case the shingles are not above three inches broad, and the extremities of each are pointed at the top.

2827. *The warped paling fence* consists of pieces of wood drove into the earth, bent down in different directions, and their tops fastened together; this fence resembles the *chevaux-de-frise*, with only this difference, that, in place of leaving the points standing up, as is the case with that part of fortification, they are bent down and tied together. When made of dead wood, this fence is equally perishable with others of the same description; but when made of growing plants, it will be found very lasting.

2828. *The light open paling fence with thorns, or the branches of trees wove in* (fig. 388.), differs from the common paling fence already described, only in being warped either with thorns, or the branches of trees. When properly done, it forms at once a very complete fence; but, like all fences made with dead wood, it will be found very perishable, and require many repairs. It has, however, one advantage, viz. that, when properly executed, it is proof against the entrance of animals of any kind.

388



2829. *Primitive paling fences* are formed without nails or tyes of any sort, by inserting the pales or stakes in the ground in different directions (fig. 389.), by using forked or hooked stakes. They are chiefly practicable in forest or park scenery for maintaining a particular character, and for separating horses, deer, &c. Such fences sometimes occur in Poland, Hungary, &c.; but in a civilized country they are to be considered more in the light of effect than of practical utility.

389



2830. *Park fences of iron* are the most efficient and elegant (figs. 390. and 391.) Light cast-iron posts with rails of round iron rods five eighths of an inch in diameter to the height of four feet, and a foot higher, on the bent extremity of the posts a chain instead of a rod (fig. 390.), is found to form a barrier against any description of the

390

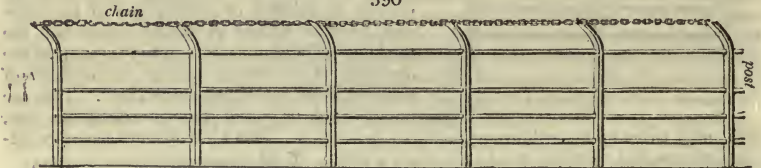

larger quadrupeds kept in British parks, as horses, wild cattle, buffaloes, deer, &c. Painted green, or even with the paint called blue anticorrosion (ground glass and oil chiefly), or coated over with the pyrolignous liquor from the gas works, such fences are not obtrusive, and less liable to suggest ideas of limitation, confinement, restraint, &c. than walls or pales. Similarly characterized fences may be composed of connected hurdles (fig. 391.), which are valuable and probably the cheapest of any fence in

391

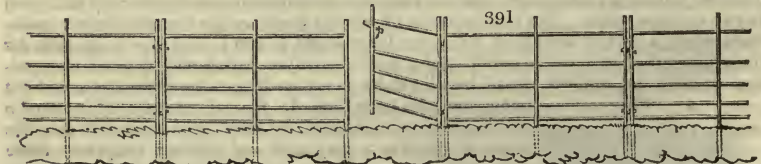

dividing rich and extensive pastures, such as a park let out to a farmer for several years grazing. For poultry, or for excluding hares, rabbits, &c. the lower part of such fences is covered with a wire netting (fig. 392.).

392

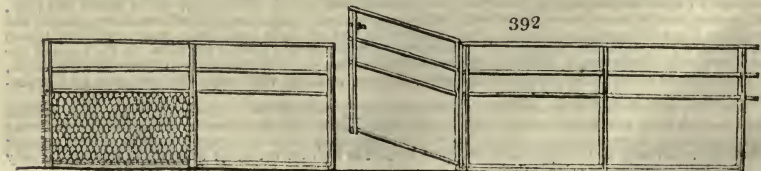

SUBJECT. 5. *Wall-Fences.*

2831. *Wall-fences* are constructed of different sorts of materials, and are of various kinds. They are for the most part good fences, though some of them, as those of the earthy kinds, are not by any means durable, and, therefore, should not be formed where other better sorts can be had recourse to. In the construction of walls, it is essential that the stones be either taken from a quarry, or consist of the largest land-stones broken in such a manner as that they may have a good flat surface, in order that they may bind well; that they be built by masons and well pinned; that they have as dry and deep a foundation as possible, in order to guard against frosts, &c.; that they be made wide at the bottom, and tapering upwards to about the breadth of ten inches, when the coping is to be applied; that the coping consist of materials that cannot be readily overturned or removed; as, upon the manner in which it is finished, much of the future value and durability of the wall will be found to depend.

2832. *Dry stone walls* are of three kinds, round stones gathered from the fields, and coped with turves; quarried stones, upon which some pains have been bestowed to put them into proper shape; and the Galloway dike, so denominated from its being originally used in that country.

2833. *The wall or dike made with round or land-stones*, by laborers, and covered with a coping of turf, is a very indifferent fence. In most instances, it is not only very ill constructed as to shape, being of one uniform thickness from top to bottom, but the stones, from their round figure, do not present a sufficient surface to each other, to bind and give stability to the building. This fence has long been known, and is still very common in the remote parts of the country, upon estates where the first rude essay is made in the way of improvement, and where masons cannot readily be had. In such situations, it has a two-fold benefit; the surface is cleared of many stones that would otherwise have presented a considerable obstacle to its cultivation, and the field is at the same time enclosed: but, though these objects are accomplished for a time, their benefit is not permanent, as the wall is perpetually tumbling down; even the cattle rubbing against it make considerable gaps in many places; and in that way, great trouble and expense are annually required to keep it in repair.

2834. *The wall in which the stones are quarried* (fig. 393.), and put together by skilful masons, broad at bottom, tapering gradually upwards, and finished at top with a substantial coping, has a very neat appearance, and has been known to last thirty and even forty years without repairs. A good foundation is highly essential in the construction of this fence; from nine to twelve inches is the smallest depth that it should be below the common surface, especially if the soil is open and porous, and the largest and heaviest stones should always be laid undermost.

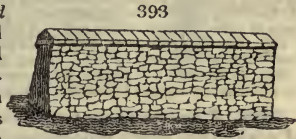

2835. *The Galloway dike or wall* (fig. 394.) is principally employed for enclosing high grounds that are depastured with sheep, for the confining of which it seems well calculated. From two feet to two and a half, at the bottom, it is built in a regular compact manner with dry stones, in every respect the same as a dry stone wall, with a broad base, tapering gradually upwards: the building is then levelled with a course of flat stones, resembling a coping, in such a manner as that these flags or flat stones shall project two or three inches over the wall on each side. Above these flat stones is laid a course of rugged round ones, placed upon each other in a way secure enough to give stability to the building, but at the same time so open as to leave a considerable vacuity between each; by which means a free passage is afforded to the light and wind, which blows through them with a violent whistling noise. This rough open part of the building is generally raised three feet above the regular part of it, gradually tapering upwards, till it terminates in a top of about nine inches broad, every course of the rough stones being smaller than that immediately beneath it. Its tottering appearance is so well calculated to prevent sheep, cattle, or other animals, from approaching it, that it is seldom indeed that any attempt is made to leap over it. This circumstance, together with the ease with which the stones are procured, in most of the situations where the Galloway dike is used, renders it a valuable fence.

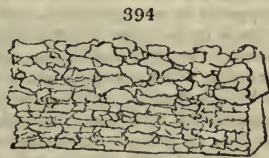

2836. *Stone and lime walls*, in order to be durable, should have a good foundation, deep enough to prevent them from being hurt by frosts, with a broad base, tapering gradually upwards. This fence, when properly executed, is, next to hedges, the most durable of any; it is, however, very expensive; and its superiority over the dry stone wall is so trifling in point of durability, as to render the latter the most eligible, it being greatly cheaper, and answering every purpose of a fence equally well. For the building of

this wall, stones taken from the quarry are to be preferred to the common land-stones; for though a mason may be able to remedy, in some measure, the inequality of surface in land-stones, by mixing plenty of lime with them, yet experience proves, that walls made with such stones, notwithstanding every care on the part of the builder, are much less perfect, and last much shorter time, than where quarried stones are employed. This, like every other stone fence, should be secured at the top with a substantial coping. Stone fences of every description not only form complete enclosures at once, and by that means allow the proprietor to enter into immediate possession of every advantage that can arise from the enclosing of his fields, but, by the little room they occupy, a considerable portion of land is saved that would have been occupied by some other fences.

2837. In the construction of *walls of stone and clay*, the clay is used like lime, and is meant to answer the same purpose. It requires slender observation, to convince intelligent persons, that a wall made with such materials in the ordinary way cannot be a durable one; for if the clay made use of in building the fence has been very moist, the summer's heat will dry it so much, as to leave considerable chasms in the building; these chasms must necessarily deprive many of the stones of that support which they require, and in that way endanger the building. This, however, is not the only inconvenience with which this kind of wall is attended; the effect of the summer's sun upon the clay parches it so completely, that when the wet weather commences about the end of autumn, it absorbs the moisture like a sponge, and if it is overtaken by frost while in that state, the fabric swells, bursts, and tumbles down.

2838. *Walls of stone and clay, dashed with lime*, differ in no respect from that described, except in the harling or dashing that is given them. Where that operation is well performed, and at a proper season of the year, the coating of lime, by preventing the entrance of moisture, will add greatly to the durability as well as beauty of the wall; so much so indeed, that some fences made in this way, where the clay was properly tempered, and did not contain too much moisture, and where a harling or dashing of lime was afterwards given, have been known to last nearly as long as walls made entirely with stone and lime.

2839. *The dry stone wall, lipped with lime*, differs from the ordinary dry stone wall, in having about two or three inches of it on each side lipped with lime, which gives it the appearance of being built entirely with stone and lime. Where the external appearance of a fence is an object, something is gained by this practice; in point of real duration, however, it seems to possess very little advantage over the common dry stone wall, which, when properly executed, lasts equally long.

2840. *Dry stone walls, lipped and harled*, are much the same, nothing more being added than a harling or dashing of lime after the other work is finished: this addition is to be considered merely as an improvement upon their appearance, and not as contributing to increase their utility, or render them more durable as fences.

2841. *Dry stoned walls, pinned and harled*, are much the same: the mason only carefully pins or fills up all the interstices of the building with small stones, after they have been built in the ordinary way, and afterwards dashes or harls them over with lime. The pinning, by filling up every vacant space, and affording complete support to the stones in every part of the surface, adds considerably to the durability of the building, and the harling afterwards gives the whole a finished substantial appearance, which renders them at once agreeable to the eye, and lasting as fences.

2842. *The dry stone wall, with a light paling upon the top*, is sometimes made, and for particular purposes answers well, and has a handsome appearance when well executed.

2843. *Brick walls* are seldom had recourse to for ordinary enclosures, except in situations where stones are extremely scarce, as is the case in some counties for pleasure-grounds, or for park or garden-walls.

2844. *Frame walls* are constructed in the following manner: a frame of deal boards, of a width and height proportioned to that of the intended fence, is placed upon the line in which it is intended to be made, a proper foundation having been previously dug; the frame is then filled with stones of all sorts, gathered principally from the adjoining fields; when the frame is filled to the top with such stones, a quantity of liquid mortar is poured in amongst them, sufficient to fill up every interstice; the whole is suffered to remain in that state till it is supposed that the mortar has acquired a suitable degree of firmness to give stability to the building, which in summer, when the weather is warm and dry, will not require above a day or two. The frame is then removed, and placed a little farther on in the same line, in such a manner as that one end of it shall join immediately with that part of the work from which it had been removed. In that way the line of fence is gradually completed, which, when the lime is of good quality and well mixed with sharp sand, and the proper pains taken to incorporate it with the stones, presents a smooth uniform surface, and will doubtless form a substantial and durable fence.

2845. *Turf walls* are met with in almost every upland or hilly district throughout Britain, and for temporary purposes are found very useful. In a variety of instances this sort of fence is used for enclosing fields, and is practised for that purpose to a very considerable extent; in others, however, it is used for the formation of folds, pens, or other places of confinement for cattle during the night. In general, the fence is made with turf only, pared off from the adjoining surface, and used without any mixture of earth; in other cases, the wall consists of a facing of turf on each side, while the space between is filled up with loose earth. For a fold, this fence answers extremely well; but for enclosing a field, or indeed any other use where durability is required, it should never be had recourse to, as, from the moment it is finished, its decay commences, and no pains or attention will be able to keep it in repair after it has stood two or three years.

2846. *Stone and turf walls* are also very common in many situations, where better and more durable ones could be made at equal, perhaps less, expense. In many instances, however, they are had recourse to, from necessity, where lime is either very dear, or not attainable at any price.



2847. *Mud walls with a mixture of straw*, were formerly frequent in many places, not only for surrounding small enclosures and stack-yards, but also for constructing the walls of farm-houses and offices, and for subdividing houses into different apartments. When either the outside walls, or the inside divisions of a house are made of these materials, the custom is, to take a small quantity of straw, and incorporate it with a sufficient proportion of clay; the straw in this case answers the same purpose as hair in plaster-lime. When a sufficient number of these are made, the work is begun by laying a stratum at the bottom of the intended wall; when this is done, and the different pieces firmly kneaded, or wrought together with the hand, a flat deal board is applied on each side, which being properly pressed, and rubbed against the building in a horizontal direction, not only serves to consolidate the work, but gives it a degree of smoothness and uniformity; successive stratums are added, till the wall is raised to the intended height, taking care to taper it gradually upwards. Walls made in this way, if properly constructed, will last for many years, and if dashed or harled with lime, at a proper season of the year, will have an appearance no way inferior to such as are made with stone and lime, along with this addition to their appearance, the harling or dashing with lime, if properly done, will, by preventing the access of moisture, render them much more durable.

2848. *Rammed earth, or en pisé walls*, are very common in France, both as fences and walls for buildings. They have been described at great length in the communications to the Board of Agriculture, and in other works, and tried in various parts of this country with tolerable success, though they are by no means suited either to our moist climate, or degree of civilization. In constructing them the earth is previously pounded, in order to crumble any stones therein; clay is added thereto in a small quantity, about one-eighth part. It is all beaten and mixed up together by repeated blows with a mallet about ten inches broad, and ten or fifteen inches long, and two inches thick. The earth being thus prepared, and slightly wetted, the foundation of the wall is dug; this is laid with stone, and when it is about one foot high above the surface of the ground planks are arranged on each side, and the space between filled with the earth intended for the wall. It is strongly beaten; and this method is continued successively, till the wall is completed.

2849. *Stamped earth walls* are the invention of Francois Cointeraux. Earth prepared in the same manner as for rammed walls, is put into a mould or box of any size, generally that of the proposed wall's thickness in width, one or two feet long, and about one foot high (fig. 395 a). The mould is a strong oaken or iron box, and the earth being placed in it, is compressed either by the action of a press acted on by a lever or screw, or a stamping engine similar to the pile driver, or great forge hammer. The stone, or solid body of earth (b), thus acquired, is then used in the same way as common hewn stone, and either bedded or merely jointed with lime mortar; it is then washed or harled, both for effect and duration.

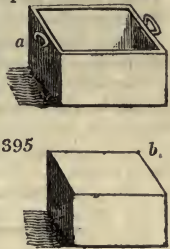

CHAP. V.

Of Gates appropriate to Agriculture.

2850. *The gate* may be considered as a moveable part of a fence, or as a frame of timber, or iron, readily moved and calculated to give a convenient inlet and outlet to enclosures. Gates may be considered in regard to the principles of their construction, and fixing; the materials of which they are made; and their different kinds.

2851. With respect to *construction* the great object is, to combine strength with lightness. The absolute strength of materials depends on their hardness and tenacity. A gate, therefore, consisting of one solid plate of wood or iron, would seem to require most force to break or tear it in pieces. But this would not be consistent with lightness and economy, and in the use of such a gate it would be found to open and shut with more difficulty, than one less strong. The skeleton of a plate of wood or iron is, therefore, resorted to by the employment of slips or bars,

disposed and joined together on mechanical principles. These principles, applied to carpentry, direct the use of what are called ties and struts, in the judicious composition of which, as far as construction is concerned, consists the whole art of carpentry. A *tie* (fig. 396 a.) is a bar, or piece of timber, so placed in a structure as to resist a drawing or twisting power; a *strutt* (b) is one so placed as to resist weight, or whatever has a tendency to press or crush. The horizontal bars of a gate are all ties; the diagonal and perpendicular ones struts. On the judicious combination of these ties and struts, depends the absolute strength of the gate; and on their lightness, and on the general form of the gate, depends its adaptation for opening and shutting by means of hinges.

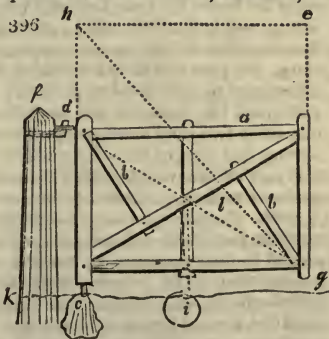

2852. *The construction of a gate best adapted for opening and shutting*, is next to be considered. All gates, after being hung, have from their gravitation a tendency to deviate from their original position, to sink at the head or falling post, and thus no longer to open and shut freely. If the construction and hanging of the gate were perfect, this could not possibly take place; but as the least degree of laxity in trussing the gate, or want of firmness in fixing the post in the ground, will occasion, after frequent use, a sensible depression at the head, it becomes requisite either to guard against it as much as possible, in the first construction; or to have a provision in the design of the upper hinge (fig. 397.), for rectifying the deviations as they take place.

2853. *In order to understand the construction best calculated to resist depression*, suppose a gate hung, and resting on its heel (fig. 396 c), acting as a strut, and maintained there by its upper hinge (d), acting as a tie, then the bottom rail of the gate considered as representing the whole, becomes a lever of the second kind, in which the prop is at one end (c), the power at the other (g), and the weight placed between them in the line of the centre of gravity of the gate (i). Now, as two equal forces, to hold each other in equilibrium, must act in the same direction, it follows that the power acting at the end of the lever (g), will have most influence when exerted at right angles to it in the line (g, e), but as this cannot be accomplished in a gate where the power must be applied obliquely, it follows, that a large angle becomes requisite; that the greater the angle, the greater the power, or in other words, the less the strain on the construction of the gate, or the less the tendency to sink at the head. The half of the right angle (c, e, g) seems a reasonable limit, by which, if the power requisite to hold the weight in equilibrium, when acting at a right angle, be as the side of a square of the length of the lower bar of the gate (g, c), then the power requisite to effect the same end, when acting at an angle of 45 degrees, is as the diagonal to this square (g, h). By changing the square to a parallelogram, the relative proportions will still be the same, and the advantages and disadvantages will be rendered more obvious.

2854. *Parker's compensation hinge for gates which are much in use* (fig. 397.), is an

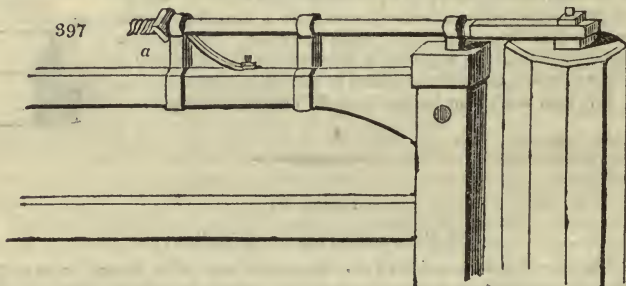

excellent corrective to their falling; all that is necessary when the gate sinks at the head is to screw it up by the nut (a), till it regains its original position. For road and farm yard gates the hinges are valuable parts of the construction.

2855. *A gate should be so hung as to have two falls*; one to the hanging post, to make it catch, and the other to a point at a right angle with the gateway, so as to keep it fully open. To effect this purpose, having set the post perpendicular, let a plumb-line be drawn upon it: on this line, at a proper height, place the hook, so that it may project three inches and a half from the face of the post; and at a convenient distance below this place the lower hook an inch and a half to one side of the perpendicular line, and projecting two inches from the face of the post; then place the top loop or eye two inches from the face of the hanging style, and the bottom loop three inches and a half: thus hung, the gate will have a tendency to shut in every position. A gate so hung will have a tendency to shut in every position; because if the weight of the gate be represented by a diagonal line from the heel to the head, this, by the resolution of forces, is resolvable into other two lines; one perpendicular, and the other horizontal; the former representing that part of the weight which presses in a perpendicular position, and the latter that part of the weight which presses in a horizontal direction, and gives the gate a tendency to shut. (*Northumb. Rep.* 63.)

2856. *Gates are generally constructed of timber*, and whatever kind may be used, it is essential that it be well seasoned, as without attention in this respect, they are soon deranged in their structure by the heat of the sun: they should also be well and correctly put together. Oak is undoubtedly the best sort of wood for the purpose, where durability is the object; though some of the lighter kind of woods, as deal, willow, &c. will often last a great length of time; as, from their lightness, they are not so apt to destroy themselves. The lighter gates are made towards the head or opening part the better,

provided they be sufficiently strong for the purpose they are to serve; and on this account the top bars may, in many cases, as where horses are to be kept, be left considerably stronger than the others. If this be not done, they are liable to be broken by the animals rubbing their necks upon them, except where they are made very high. Gates are generally made eight and an half or nine feet in width, and from five to six feet in height; the bars being three or four feet broad, and five or six in number. In particular instances a smaller bar is introduced between the two lowermost ones, in order to prevent small animals getting through.

2857. *Iron, both hammered and cast metal*, has long been in use for ornamental gates (fig. 398.), and has lately come into use in some districts for field gates. Their eligibility

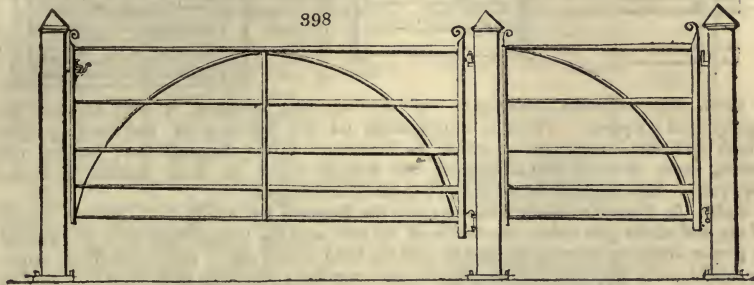

must depend on their price and durability relatively to wood. At the ordinary prices of wrought iron and oak, they will be found of doubtful economy; cast iron gates are too heavy, and too liable to be broken, for agricultural purposes.

2858. *The posts or pillars to which gates are attached* should, in all convenient cases, be formed of stone; as this material, when hewn and properly constructed, will last for ages. When formed of wood, oak or larch are the best sorts. The latter, where suitable, should be used without removing the bark, which has been found to add greatly to their durability. In some places it is customary to plant trees for gate-posts, and after they have attained a certain size and thickness, to cut them over about ten feet above the surface: where the trees thrive, they form the most durable of all gate-posts; in many instances, however, they misgive, and much trouble is necessary to repair the defect. Where the posts are made of *dead timber*, they should always be strong, and the wood well prepared; that part which is let into the earth should also be defended, by dipping it in coarse oil, or giving it a coat of pyrolignous liquor; and all that is above ground exposed to the action of the weather, should be well covered with one or two good coats of oil-paint. The expense of this preparation is but trifling, while the benefit is very great.

2859. *The substance of a gate-post*, according to Parker, should be from eight to ten inches square, or, for very heavy gates, a foot square would not be too large. If made of still larger size, it is better. And he says, that the steadiness of a gate-post depends, in a great measure, upon the depth to which it is set in the ground, which ought to be nearly equal to the height of it. Five or six feet is, in general, fully sufficient. But the posts may be kept in their places by a strong frame-work placed under the ground, extending between the posts.

2860. *The fastenings of gates*, it is observed by Parker (*Essay, &c.* 1816.), are as various as the blacksmiths who construct them: the subject occupied his attention in connection with the hanging of gates, and he has introduced various improved forms. One of the most secure (fig. 399.), is a spring-latch (a), opened by a lever (b), which works in a groove of the upper bar of the gate, and therefore cannot be rubbed open by cattle, while, by means of a knob at the end of the lever, and rising up against the top of the upright bar (c), so that cattle cannot touch it, it is very easily opened by persons on horseback with or without a stick or whip.

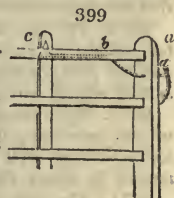

2861. *A simple, economical, and effective spring-latch* consists of a bolt (fig. 400 a.), which is loose, and plays freely, in two mortised openings in the upright bars, and is kept in place by a spring (b). The gate may be shut from either side, when the bar, striking against the projection (c) on the falling post is pushed back, till, arriving at the mortise (e), the spring (b) forces it in, and the gate is shut securely. Such a gate is easily opened by a rider. This is a good latch for the common field gates of a farm.

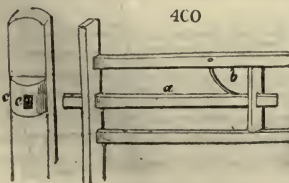

2862. For gates of an ornamental kind, Parker says, he does not know a better latch than the crooked lever (fig. 401.) now in common use.

2863. Gates are of different kinds (figs. 402. and 403.), according to the particular custom of the district; but the principal sorts made use of are the swing-gate, the folding-gate, the slip-bar gate, and the wicket and turn-about gate.

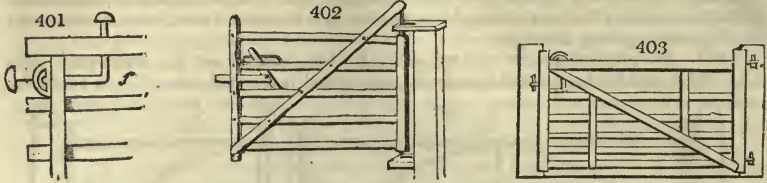

2864. The improved swing-gate of the northern counties is well adapted for agricultural purposes. There is a projection on the fore-part of the hanging-style, which rises nine inches, and on which the lower end of the diagonal bar, passing upwards, rests; there is also a diagonal bar through which the three middle horizontal bars pass. It is found to be a very strong and durable gate.

2865. In Parker's improved swing-gate, the diagonal bar rising from the lower part of the heel of the gate meets the middle of the rail, and the two upright bars are placed at proper distances between the middle and the head of the gate: these cross-bars must, he thinks, assist very much in keeping the gate together; but what is most to be guarded against is, its sinking at the head, and to prevent which, this gate (he says) is well contrived.

2866. The tressel-bar gate (fig. 404.) consists of two bars, one hung by a few links to each gate-post, and in the middle of the opening, where the bars meet, they are supported by two legs like a tressel, and may be padlocked, or fastened by a pin and a few links, &c. In the promenade at Florence such gates are made use of to close the larger carriage openings.

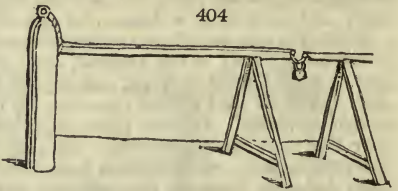

2867. The slip-bar gate is, perhaps, the most durable of any, especially where the gate-posts are of stone, with proper openings left for the reception of the bars. The only objection that can possibly be made to the slip-bar gate is, the trouble of opening and shutting; which, when servants or others are passing through it, in a hurry, occasions its being frequently left open. In other respects, it is preferable to every other description of gate, both in the original cost, and greater durability. It is to be noticed, however, that upon the verge of a farm or estate, especially where it is bounded by a high road, the slip-bar gate will not answer, as it does not admit of being locked, or secured in the same way as other gates; but in the interior of a farm or estate, it will be found the cheapest sort of gate.

2868. The chained slip-bar gate, though more expensive, is not liable to the same objections as the last. Here the bars are connected by a chain down the middle of the gate, and, therefore, if one bar is padlocked to the post, none of them can be moved till that one is unlocked.

2869. The turn-about, or wicket-gate, is only used in cases where there is a necessity for leaving an entry for the people employed to pass backwards and forwards. This purpose they answer very well, and at the same time keep the field completely enclosed, as they require no trouble to shut them in the time of passing.

2870. Styles are contrivances for man to pass over or through fences, without the risk of even permitting the larger quadrupeds to accompany or follow him. There are many forms perfectly well known every where; as by steps over a wall; by a zig-zag passage, formed by stakes, through a hedge or paling; a turning-bar or turnstyle, &c.

2871. The style of falling bars (fig. 405.) is chiefly used in pleasure-grounds, or be-

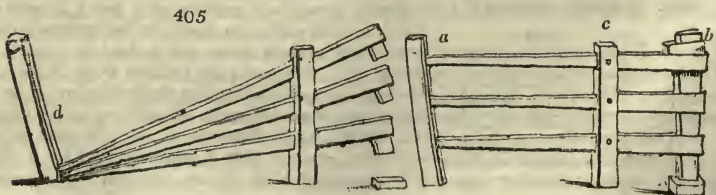

tween paddocks: it consists of bars light at one end (*a*), and heavy at the other (*b*), with concealed joints or pivots, in an upright post (*c*), placed nearer one end of the bars than the other. Then, while the weight of the short ends of the bars keeps them in a fencible position, a slight pressure on the other end will form a passage (*d*), which any one may easily step across.

2872. *Bridges* are frequently required on estates and farms for crossing ditches and water-courses. They are generally large stone conduits or barrel-drains; or in the case of large streams, arches of masonry. In the case of small drains, wooden pipes or boarded tubes are sometimes resorted to, and even earthen pipes have been used; but masonry should always have the preference.

2873. *The double or folding-gate* (*fig. 406.*), is considered by some to be much more



406 durable than those of the swing kind; because the bars, from being only half the length, render the joints

so liable to be broken, or the hinges to be hurt by straining. On the other hand, such gates require more time and attention in the opening and shutting, and the latter operation is troublesome to perform, when both halves have fallen at the head. These gates are not, therefore, in such general use in agriculture as the swing kind; but they are common as gates to parks, and other scenes of dignity and ornament.

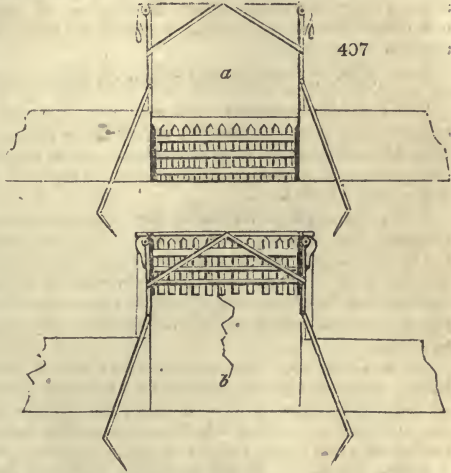

2874. *Clarke's window-sash gate* (*fig. 407.*) is a recent invention, which may be of use in some cases, especially in farm-yards. It is suspended by two weights, and opens and shuts exactly on the principle of the window-sash. The weights may be of stone or cast-iron, and the pulleys are of iron, and nine inches diameter. It was applied in the first instance to a cattle-court; but has since been erected in different situations. Its advantages the inventor considers to be the following: It is easy to open (*b*), or shut (*a*); remains in whatever situation it is placed; is not liable to be beat to pieces by the action of the wind; shuts always perfectly close, whatever be the height of the straw or dung in the court or gate-way; a cart may be driven quite close on either side before opening; is perfectly out of the way when fully open, and not liable to shut on what is passing; the gate bottom not liable to decay by being immersed in the dung, as is commonly the case with cattle-court gates; not liable to go out of order; may be erected in a hollow place, where a swinging-gate could not open either outwardly or inwardly; and is likely to be more durable than ordinary gates. A small gate of this description (*fig. 408.*) is said, by Lasteyrie (*Col. de Machines &c.*), to have been long in use by the Dutch.

408



BOOK V.

OF THE OPERATIONS OF AGRICULTURE.

2875. *The operations of agriculture* are effected under the direction of man, and by means of the mechanical agents, or implements and buildings which we have passed in review in the preceding book. They are either made directly on plants or animals, which may be considered the objects of agriculture; or on the soil and climate, which are the natural agents of growth and culture. They may be arranged as manual labors and operations, operations with beasts of labor, and mixed operations.

## CHAP. I.

*Manual Labors and Operations.*

2876. *The labors and operations* of any art can seldom be described with great advantage. Whoever wishes to acquire them should resort at once to the scene of practice: no description, however minute, will teach a man to dig, plough, or mow, equal to a few hours' trial in the field, though a knowledge of the mechanical principles on which the implements and the human machine acts in such operations, will afford some assistance in acquiring them, and in performing them with ease. Our observations shall chiefly be directed to these parts of the subject, and to the most suitable weather and other circumstances for the performance of the different field labors of the manual kind. We shall arrange these as manual labors common to all arts; manual operations on the soil; and mixed manual operations, or such as are performed on the soil, plants, and animals together or connectedly.

SECT. I. *Mechanical Operations common to all Arts of Manual Labor.*

2877. *All the operations which man performs with implements or machines*, are, as far as his own person is concerned, reducible to lifting, carrying, drawing, and thrusting. Man himself, considered as an engine, derives his power from alterations in the position of his centre of gravity, and he applies it chiefly by his hands, arms, and legs, acting as levers of the third kind.

2878. *Lifting* is performed by first stooping or lowering the centre of gravity, and at the same time throwing it to one side. The object being then laid hold of by the hands, the body is raised, and the centre of gravity, in being restored to its true position, acts as a counterbalancing weight to the weight to be raised. The weight retained by the hand is now raised a certain height, never exceeding half that of the man; if to be raised higher, recourse is had to muscular strength, or the power of the arms to act as levers.

2879. *Carrying*. To carry a thing is merely to walk with a greater weight than before, and walking is performed by a series of alternate derangements and adjustments of the centre of gravity, slow or rapid, according as the person may walk or run. According to Delolm, the most advantageous weight for a man of common strength to carry horizontally is 112 lbs.; or, if he returns unladen, 135 lbs.

2880. *Drawing*. In this operation, the upper part of the body is thrown forward, so as to act as a power to counterbalance or lift up the body or weight to be moved; and by joining to this lifting motion the operation of walking, the weight is at once lifted up and drawn along. This compound operation is exemplified in a horse, when straining at a draught in a plough or cart. He first lowers his chest, then raises it, and lastly steps forward. When drawing at ease, the lifting motion is scarcely distinguishable from the progressive one.

2881. *Pushing or thrusting* is performed exactly on the same principles as drawing, and differs from it chiefly in the kind of implement or machine which requires to be employed, all machines which are to be pushed requiring to be attached to the animal machine by parts acting by their rigidity; whereas those to be drawn may be attached by parts acting by their tenacity merely.

2882. *Wheeling* is a mode of carrying materials in which the weight is divided between the axle of the wheel and the arms of the operator. The arms or shafts of the barrow thus become levers of the second kind, in which the power is at one end, and the fulcrum at the other, and the weight between them. The weight is carried or moved on by the continual change of the fulcrum with the turning of the wheel; and this turning is produced by the operator throwing forward his centre of gravity so as to push against the wheel by means of the moveable axle, &c. The chief obstacles to wheeling are the roughness or softness of the surface to be wheeled on. Where this is firm, there wheeling will be best performed with the greater part of the load resting on the axle; but when soft and deep, the centre of gravity should be nearest the operator, who will find it easier to carry than to overcome excessive friction. Dry weather is obviously preferable for this operation. "With wheelbarrows," Dr. Young observes, "men will do half as much more work as with hods."

2883. *All these operations may be varied in quantity*, either by a variation in the weight or gravity of the man, or moving power; or by a variation in the time or rapidity of his motions. Thus a heavy man may, in one movement, lift a weight ten times greater than can be done by one of less weight; but a light man may, by increasing the time of performance, lift the same weight at ten times. A man, who in digging can apply with his feet five cwt. of his weight towards pushing the wedge or blade of the spade into the soil, has an apparent advantage over a lighter man who can only apply three cwt. of mere gravity for that purpose; but yet the latter may equal the former, by accompanying his power or foot with a proportionate increase of motion. The power in this last case

is said to be obtained by the momentum, or quantity of matter in a body multiplied by the velocity with which it is moved. Power, therefore, we thus ascertain, is obtained by matter and motion jointly, and what may be deficient in the one, may be made up by excess in the other. Thus, a small, light workman may (though with more animal exertion,) produce as much work as a larger or heavier man: for if we suppose the quantity of matter in the large man to be thirty, and his motion at the rate of two, then if the quantity of matter in the small man be twenty, and his motion at the rate of three, he will produce an equal effect with the large man. As small human machines, or men, are generally constructed of finer materials, or more healthy and animated, than large ones, the small man performs his rapid motions with nearly as great ease to himself as the heavy man moves his ponderous weight; so that in point of final result they are very nearly on a par.

#### SECT. II. *Agricultural Labors of the Simplest Kind.*

2884. *The manual labors of the field* are, next to the general labors enumerated, among the simplest required of the human operator, who, provided he has health and strength, may perform them with very little skill.

2885. *Breaking stones* is an easy labor requiring very little skill, and no great degree of strength. The stones are previously reduced in the quarrying, or otherwise, to such sizes as can be broke by one or more blows of an iron headed hammer. In general they are broke on the same plane on which the operator stands, but the blow has more effect when the stone is raised about eighteen inches, and for small stones, the most work will be done when they are broke on a table nearly as high as a man's middle, which is now the practice under the direction of the best road makers.

2886. *Picking.* The pick is a blunt wedge, with a lever attached to it nearly at right angles, and the operation of picking consists in driving in the wedge so as to produce fracture, and then causing it to operate as a compound lever by the first lever or handle, so as to effect separation, and thus break up and loosen hard, compact, or stony soils. It is also used to loosen stones or roots; and the pick-axe is used to cut the latter. For breaking and pulverizing the soil, the most favorable conditions are, that the earth should be moderately moist, to facilitate the entrance of the pick, but in tenacious soils not so much so as to impede fracture and separation.

2887. *Digging.* The spade is a thin wedge, with a lever attached in the same plane, and the operation of digging consists in thrusting in the wedge by the momentum (or weight and motion,) of the operator, which effects fracture; a movement of the lever or handle next effects separation, whilst the operator, by stooping and rising again, lifts up the spitful or section of earth on the blade or wedge of the spade, which, when so raised, is dropped in a reversed position, and at a short distance from the unbroken ground. The separation between the dug and undug ground is called the trench or furrow; and when a piece of ground is to be dug, a furrow is first opened at that end of it where the work is to commence, and the earth carried to that end where it is to terminate, where it serves to close the furrow. In digging, regard must be had to maintain an uniform depth throughout, to reverse the position of each spitful, so as what was before surface may now be buried; to break and comminute every part where pulverisation is the leading object; to preserve each spitful as entire, and place it separated or isolated as much as possible where aeration is the object; to mix in manures regularly where they are added; to bury weeds not likely to rise again, and to remove others, and all extraneous matters, as stones, &c. in every case. For all these purposes a deep open trench is requisite, and that this may not be diminished in width and depth in the course of the operation, it must never be increased in length. If allowed to become crooked by irregular advances in the digging, it is thus increased in length, and necessarily diminished in capacity, unless, indeed, the dug ground is allowed to assume an uneven surface, which is an equally great fault. Digging for pulverisation, and mixing in manures, is best performed in dry weather; but for the purposes of aeration, a degree of moisture and tenacity in the soil is more favorable for laying it up in lumps or entire pieces. The usual length of the blade of the spade is from ten inches to a foot, but as it is always inserted somewhat obliquely, the depth of pulverisation attained by simple digging seldom exceeds nine inches, and in breaking up firm grounds it is seldom so much.

2888. *Shovelling* is merely the lifting part of digging, and the shovel being broader than the spade, is used to lift up fragments separated by that implement or the pick.

2889. *Marking with the line* is an operation preparatory to some others, and consists in stretching and fixing the line or cord along the surface by means of its attached pins or stakes, in the direction or position desired, and cutting a slight continuous notch, mark, or slit in the ground, along its edge with the spade.

2890. *Trenching* is a mode of pulverising and mixing the soil, or of pulverising and changing its surface, to any greater depth than can be done by the spade alone. For

trenching with a view to pulverising and changing the surface, a trench is formed like the furrow in digging, but two or more times wider and deeper; the plot or piece to be trenched is next marked off with the line into parallel strips of this width; and beginning at one of these, the operator digs or picks the surface stratum, and throws it in the bottom of the trench. Having completed with the shovel the removal of the surface stratum, a second, and a third, or fourth, according to the depth of the soil and other circumstances, is removed in the same way; and thus, when the operation is completed, the position of the different strata is exactly the reverse to what they were before. In trenching, with a view to mixture and pulverisation (*fig. 409.*), all that is necessary is to open at one corner of the plot, a trench or excavation of the desired depth, three or four feet broad, and six or eight feet long. Then proceed to fill this excavation from one end by working out a similar one. In this way proceed across the piece to be trenched, and then return, and so on in parallel courses to the end of the plot, observing that the face or position of the moved soil in the trench must always be that of a slope, in order that whatever is thrown there may be mixed, and not deposited in regular layers as in the other case. To effect this most completely, the operator should always stand in the bottom of the trench, and first picking down, and mixing the materials, from the solid side (*a*), should next take them up with a shovel, or throw them on the slope or face of the moved soil (*b*), keeping a distinct space of two or three feet between them.



For want of attention to this, in trenching new soils for plantations, or other purposes, it may be truly said that half the benefit derivable from the operation is lost. In general in trenching, those points which were mentioned under digging, such as turning, breaking, dunging, &c. required to be attended to, and sometimes an additional object, that of producing a level from an irregular surface, is desired. In this case double care is requisite to avoid forming subterraneous basins or hollows, which might retain water in the substratum, at the bottom of the moved soil, and also to mix inferior with better soil, &c. where it becomes requisite to penetrate into depositions of inferior earthy matters.

2891. *Ridging* is a mode of finishing the surface, applicable either to dug or trenched grounds, which, when so finished, are called ridge-dug or ridge-trenched. Instead of being formed with an even surface, ridged grounds are finished in ridges or close ranges of parallel elevations, whose sections are nearly equilateral triangles. Hence, supposing the triangles to touch at their bases, two-thirds of more surface will be exposed to the influence of the atmosphere and the weather, than in even surfaces.

2892. *Forking*. The fork is composed of two or three separate, parallel, and uniform wedges, joined so as to form one general blade, which is acted on like the spade, by means of a shoulder or hilt for thrusting it into the matters to be forked, and a lever or handle for separating and lifting them. Forking is used for two purposes; for pulverising the soil among growing crops, and for moving vegetable manures. In the first case the operation is similar to digging, the only difference being that pulverisation is more attended to than reversing the surface; in the other, the fork separates chiefly by drawing and lifting; hence, for this purpose a round-pronged (or dung) fork, produces least friction during the discharge of the fork-full and reinsertion; and a broad-pronged fork separates and lifts more readily the soil. Dry weather is essentially requisite in forking soils, and most desirable for spreading manures; but dung-hills may be turned during rain, with no great injury.

2893. *Dragging out dung or earth* is performed by the dung-drag, and is adopted in the case of distributing dung from a cart in regular portions or little heaps over a field. When lime, in a state of pulverisation, earth, or sand, is to be distributed in the same way, a scraper or large hoe is used; and sometimes for want of these the dung-drag, aided by the spade or common hoe.

2894. *Hand-hoeing* is performed by drawing or thrusting the wedge or blade of the draw or thrust-hoe along the surface of the soil, so as to cut weeds at or under the surface, and slightly to pulverise the soil. It is used for four purposes, sometimes together, but commonly separate; first, to loosen weeds or thin out plants, so as those hoed up may die for want of nourishment, or be gathered or raked off, for which purpose either the thrust or draw-hoe may be used; the second, to stir the soil, and for this purpose when no weeds require killing, the pronged hoe is preferable, as being thrust deeper with less force, and as less likely to cut the roots of plants; the third, is to draw



up or accumulate soil about the stems of plants, for which purpose a hoe with a large blade or shovel, will produce most effect; and the fourth, is to form a hollow gutter or drill, in which to sow or insert the seeds of plants, for which a large or small draw-hoe may be used, according to the size of the seeds to be buried. The use of the hoe for any of the above purposes requires dry weather.

410

2895. *Hoeing between rows of crops*, is sometimes performed by what is called a hoe-plough, which is a small plough having a share with double fins, and drawn by one man, and pushed by another. It is in use in India, and is sold in London under the name of the Indian hoe-plough, but it is more for the exercise of amateurs on free soils, than for useful culture. In this way a master may exercise both himself and his valet, and clear his potatoes or turnip crop at the same time. The Dutch have a hoe (fig. 410.), which is drawn and pushed at the same time, for the purpose of cleaning walks, or scraping turf or mud from roads or court-yards.

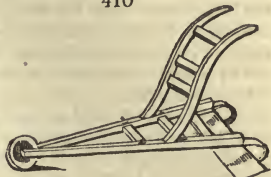

2896. *Hand raking* is performed by drawing through the surface of the soil or over it, a series of small equidistant wedges or teeth, either with a view to minute pulverisation, or to collecting herbage, straw, leaves, stones, or such other matters as do not pass through the interstices of the teeth of the rake. The teeth of the rake being placed nearly at right angles to the handle, it follows that the lower the handle is held in performing the operation, the deeper will be the pulverisation when that is the object; and, on the contrary, that the higher it is held, the interstices being lessened, the fewer extraneous matters will pass through the teeth. The angle at which the handle of the rake is held must therefore depend on the object in view; the medium is forty-five degrees. For all raking, dry weather is essentially requisite, and for raking hay the angle which the handle of the rake makes with the ground's surface, ought to be fifty degrees.

2897. *Scraping* may be described the drawing a large broad blunt hoe along the surface, for the purpose of collecting loose excrementitious or other useless or injurious matters from roads, yards, or from grassy surfaces to be rolled or mown. The Dutch hoe (fig. 410.) is a good road and lawn scraper.

2898. *Sweeping* is a mode of scraping by a bundle of flexible rods, twigs, or wires, which enters better into the hollows of irregular surfaces, and performs the operation of cleaning more effectually. In agriculture it is used in barns and in stables, though shovelling is generally sufficient for the common stable and ox-house.

2899. *Screening or sifting* earth or gravel, are operations performed with the gravel-sieve or earth screen for separating the coarser from the finer particles. The materials require to be dry, well broken, and then thrown loosely on the upper part of the screen, which being a grated inclined plane, in sliding down it, the smaller matters drop through while the large ones pass on and accumulate at the bottom. In sifting, the same effect is more completely, but more laboriously produced by giving the sieve a circular motion with the arms.

2900. *Gathering* is a very simple operation, generally performed by women and children, as in taking up potatoes or other roots, or picking up stones, weeds, or other matters considered injurious to the surface on which they lie or grow.

2901. *Cleaning roots or other matters*, is generally performed by washing, and on a large scale, by the root washing machine, which has already been described, together with the mode of using it.

2902. *Various manual labors and operation* might be added; such as slicing turnips; chopping them with the chopping hoe (2456.) in the fields; cutting straw or hay into chaff; bruising beans or other grain, or whins, or thistles between rollers; pushing a drill-barrow, &c.; all which require only bodily exertion, with very little skill; being performed by the aid of machines, which in describing, we have also indicated the mode of working (2466. to 2474.).

### SECT. III. *Agricultural Operations with Plants.*

2903. *Agricultural operations with the vegetable kingdom* rank higher than those with the soil or machines, as requiring not only strength, but some of them a considerable degree of skill.

2904. *Weeding*, however simple an operation, requires a certain degree of botanical skill to know what to weed or extract. These are such plants as it is not desired to cultivate. The operation is performed in various ways: by the hand simply; by the hand, aided with a broad-pointed knife, or a bit of iron hoop; by the hand, aided by gloves tipped with iron; by pincers, as in weeding tall weeds from growing corn, or close-hedges, or out of water; and by the aid of forks, spuds, or other weeding tools. In weeding, it is essential that the weeder know at sight the plants to be left from such as are to be removed, which in agriculture is generally a matter of no difficulty, as, however numerous the weeds, the cultivated plants are but few. In weeding ferns, thistles, nettles, &c. from pasture lands, it has been found that breaking or bruising them over

renders the roots much less liable to spring again the same season, than when they are cut or even pulled up. For this sort of weeding the pincers seem well adapted.

2905. *Thinning* or reducing the number of plants on any surface, is sometimes performed by hand, but most generally by the hoe. Thinning, to be perfectly performed, ought to leave the plants at regular distances; but as this can seldom be done, owing to the irregularity with which seeds come up, whether sown in drills or broadcast, an attempt to compensate the irregularity is made by a similar irregularity in the distances allowed between the plants at such places. Thus, if turnips in rows are to be thinned out to nine inches distance in the row, and a blank of eighteen inches or two feet occurs, the last two plants on each side the blank may be left at half the usual distance, or less, by which means each plant having ample room on one side, they will grow nearly as large as if left at the usual distance. The same principle is to be attended to in thinning broadcast crops, or trees in a plantation. Thinning may be performed in moist weather; but dryness is greatly to be preferred, especially where the hoe is used.

2906. *Planting* is the operation of inserting plants in the soil with a view to their growth, and the term is also applied to the insertion of seeds, roots, or bulbs, when these are inserted singly.

2907. *Planting as applied to seeds and tubers*, as beans, potatoes, &c. is most frequently performed in drills, but sometimes also by making separate holes with the dibber. In either case, the seeds or sets are deposited singly at regular distances, and covered by raking or harrowing, with or without pressure, according as the soil is more or less loose, and dry, or moist. In general, planting seeds or tubers in drills, or in single openings made by a draw hoe or spade, is greatly preferable to planting with the dibber, because, in the former case, the earth can seldom be placed in close and somewhat firm contact with the seed or set; a circumstance essential to its speedy germination, and vigorous future growth.

2908. *Planting, as applied to plants already originated*, is commonly termed *transplanting*. Transplanting may be considered as involving four things: first, the preparation of the soil to which the plant is to be removed; secondly, the removal of the plant; thirdly, its preparation; and, fourthly, its insertion in the prepared soil. Preparation of the soil implies, in all cases, stirring, comminution, and mixing; and sometimes the addition of manure or compost, according to the nature of the soil and plants to be inserted. The removal of the plant is generally effected by loosening the earth around it, and then drawing it out of the soil with the hand; in all cases avoiding, as much as possible, to break or bruise, or otherwise injure the roots. In the case of small seedling plants, merely inserting the spade, and raising the portion of earth in which they grow, will suffice; but in removing large plants, it is necessary to dig a trench round, or on one side of the plant. In some cases, the plant may be lifted with a ball or mass of earth, containing all or great part of its roots; and in others, as in the case of large shrubs or trees, it may be necessary to open the soil around them a year previously to their removal, and cut the larger roots at a certain distance from the plant, in order that they may throw out fibres to enable them to support the operation of transplantation. By two years previous preparation, and the use of a machine (fig. 411.), very large trees of such kinds as stole may be removed; but resinous trees seldom succeed.



2909. *The preparation of the plant* consists in pruning its roots, and top or shoots. In the smallest seedlings, such as cabbage-plants and thorns, all that is necessary is to shorten a little the tap or main root; but in seedlings of trees two or three years old, or in transplanted or large trees, several of the side shoots will require to be shortened, and also the roots, always proportioning what is taken off the top or shoots, to what has been taken from the root; that the latter may be duly fitted to support the former.

2910. *The insertion of the removed plant in the prepared soil*, is performed by making an excavation suitable to the size of the plant's root, inserting it therein, filling up the interstices with fine earth, and then compressing the whole by the hand, dibber, foot, or what is best, by abundant watering. Plants should not be inserted deeper in the soil than they were before removal; they should be placed upright, and the same side should be turned towards the sun as before; the fibrous roots should be distributed equally round the stem among the mould or finer soil; and the most difficult and important part of the whole, is to compress the earth about the roots without crowding them or injuring

them by bruises. The only effectual way of attaining this end is after carefully spreading the fibres, and distributing them as equally as possible among the mould, to give abundant waterings, holding the vessel from which the water is poured as high as possible, so as to consolidate the earth by that means, rather than by compression with the foot. On an extensive scale, however, this cannot be done, and in planting seedlings or cuttings it is not required, as these have few and short fibres, and may be *firmed* sufficiently by the planting instrument, or the foot. It should never be forgotten that, in all planting, it is an essential point to have the earth firmly compressed to the roots, and especially to the lower parts or extremities. Any one may be convinced of this, by planting one cabbage loosely, and another compressing the root well with the dibber at the lower part: or, instead of a cabbage, try a cutting, say of gooseberry, elder, or vine: both no doubt will grow, but the growth of the plant or cutting compressed at the lower extremity, will be incomparably more vigorous than that of the other.

2911. *Watering* becomes requisite for various purposes; as alimnt to plants in a growing state; as support to newly transplanted plants; for keeping under insects; and keeping clean the leaves of vegetables. One general rule must be ever kept in mind during the employment of water; that is, never to water the top or leaves of a plant when the sun shines. A moment's reflection will convince any one that this rule is agreeable to the laws of nature, for during rain the sun's rays are intercepted by a panoply of fog or clouds. All artificial watering, therefore, should be carried on in the evening, or early in the morning, unless it be confined to watering the roots, in which case, transplanted plants, and others in a growing state, may be watered at any time; and if they are shaded from the sun, they may also be watered over their tops.

2912. *Sowing* is the operation of dispersing seeds over the surface of the soil, with a view to their future vegetation and growth. Where seeds are deposited singly, they are said to be planted, as in the case of dibbling wheat or beans; where they are dropped in numbers together, they are said to be rown. When dropped in numbers together in a line, they are said to be drilled or sowed; and when scattered over the general surface by the hand, they are said to be sown broadcast.

2913. *In broadcast sowing*, the operator being furnished with a basket (*fig.* 264.), or sheetful of seed hanging on his left side, takes out a handful with his right hand, and disperses it by a horizontal and rather rising movement of the arm to the extent of a semicircle, gradually opening his hand at the same time. The most usual practice when land is laid up in ridges of equal breadth, and not too wide, as five or six yards, is that of dispersing the seed regularly over each land or ridge, in once walking round; the seedsman, by different casts of the hand, sowing one half in going, and the other in returning. In doing this, it is the custom of some seedsmen to fill the hand from the basket or bag, which they carry along with them, as they make one step forward, and disperse the seed in the time of performing the next; while others scatter the seed, or make their casts, as they are termed by farmers, in advancing each step. It is evident, therefore, that in accomplishing this business with regularity and exactness, there is considerable difficulty, the proper knowledge and habit of which can only be acquired by experience. It is consequently of importance for the cultivator to perform the operation himself, or to be careful in selecting such persons as are conversant with the business, as he may otherwise incur much unnecessary expense in the waste of seed, and run considerable risk in respect of his crops.

2914. *Sawing*. The saw is a conjoined series of uniform wedges, which, when drawn or thrust in succession across a branch or trunk, gradually wears it through. In performing the operation, the regularity of the pressure and motion are chiefly to be attended to. In green or live shoots, the double-toothed saw produces less friction on the sides of the plate, by opening a large channel for its motion. Where parts are detached from living trees, the living section ought generally to be smoothed over with a knife, chisel, or file; and a previous precaution in large trees, is to cut a notch in the lower part of the branch immediately under and in the line of the section, in order to prevent any accident to the bark, when the amputated part falls off. Sawing is a coarser mode of cutting, mowing, or shaving; or a finer mode of raking, in which the teeth follow all in one line.

2915. *Cutting* is performed by means of a very sharp wedge, and either by drawing this through obliquely or across the body to be cut, as in using the knife; or by pressing or striking the axe or hedge-bill obliquely into the body, first, on one side of an imaginary line of section, and then on the other, so as to work out a trench across the branch or trunk, and so effect its separation. The axe, in gardening, is chiefly used in felling trees, and for separating their trunks, branches, and roots into parts. The knife is extensively used for small trees, and the hedge-bill and chisel for those of larger size. In amputating with the knife, one operation or *draw-cut* ought generally to be sufficient to separate the parts; and this ought to be made with the knife sufficiently sharp, and the motion so quick as to produce a clean, smooth section, with the bark uninjured.

2916. Every *draw-cut* produces a smooth section, and a fractured or bruised section; and one essential part of cutting living vegetables, is to take care that the fractured section be on the part amputated. Another desirable object is, that the section of the living or remaining part should be so inclined (fig. 412 a.), as not to lodge water or overflowing sap, and so far turned to the ground (d), or to the north, as

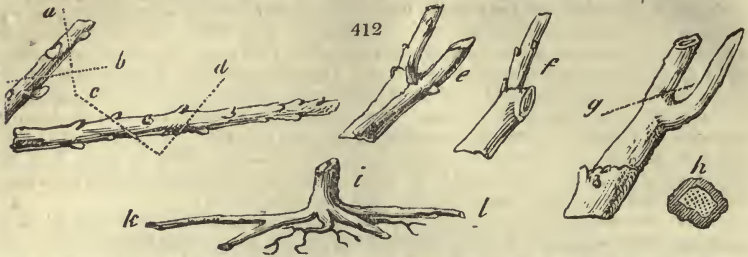

not to be struck by the direct rays of the sun. To accomplish both these purposes, as well as to make sure of having the fractured section on the part amputated, the general practice is to cut from below, or from the under edge of the branch or shoot, unless the position of the leading bud occasions a deviation from the rule (b). The cuts should also be made, in all shoots of not more than three or four years old, within from one-fourth to half an inch, or a little more, of the bud intended to take the lead; when this is not done, and half an inch or more of shoot is left without a bud (c and e), the consequence is, the stump dies back to the bud in the course of the season (g), and if not carefully cut off (f), will end in a decaying orifice both unsightly and injurious. The bud selected for a leader ought always to be a leaf-bud, and in general the plane of the section ought to be parallel to the angle which the bud makes with the stem (d). Exceptions occur in the case of plants with much pith (h), as the vine, elder, &c. in cutting the year-old shoots of which, an inch or more ought to be left, as these always die back a few lines; and thus the leading bud might be injured, if this precaution were not taken. In pruning roots, the same principle, as far as applicable, ought to be attended to; the trunk or stem when cut over ought to be sloped to the north (i), and the lateral roots cut so as the section may be on the under side (k), and therefore less likely to rot than when the cut faces the surface of the ground (l), or is bruised by neglecting to form the smooth section on the attached extremity.

2917. In like manner, when pruning a large tree, the section of amputation ought to be made so oblique as to throw off the rain; as generally as possible, it should be turned from the sun, and rather downwards than upwards, in order to shield it from heat and cracking; and whenever it can be done, it should be made near a branch, shoot, or bud, which may take the lead in the room of that cut off, and thus, by keeping the principle of life in action at the section, speedily heal up the wound.

2918. In cutting with the chisel, the blade is applied below the branch to be amputated, so as to rest on the trunk or main branch, and so applied, a quick blow with a mallet is given to the handle of the chisel by the operator or his assistant. If this does not effect a separation, it is to be repeated. In forest-pruning it is often advantageous to apply one cut of the chisel on the underside of the branch, and then saw it through with the forest-saw from the upper.

2919. *Clipping* is an imperfect mode of cutting adapted for expedition, and for small shoots. The separation is effected by bruising or crushing along with cutting, and, in consequence, both sections are fractured. In agriculture, it is chiefly applied for keeping hedges in shape; but the hedge-knife, which operates by clean, rapid draw-cuts given always from below, is generally preferable, as not decreasing the live ends of the amputated shoots. The new pruning-shears and the averuncator, it is to be observed, by producing cuts much more like the draw-cuts of knives, are greatly to be preferred to the common hedge-shears.

2920. The best seasons for sawing, cutting, or clipping living trees are early in spring, and in midsummer. Early in autumn, trees are apt to bleed; later, and in winter, the section is liable to injury from the weather; but trees pruned early in spring remain only a short period before they begin to heal; and in those pruned at midsummer, wounds heal immediately. There are, however, exceptions as to spring-pruning in ever-greens, cherries, and other gummiferous trees; and summer-pruning is but ill adapted for forest work or trees in crowded scenery.

2921. *Splitting* is an operation generally performed on roots of trees remaining in the soil for the purpose of facilitating their eradication. The wedge, in its simplest form, and of iron, is driven in by a hammer or mallet, till it produces fracture and separation, when the parts are removed as detached, &c.

2922. *Pruning*, or the amputation of part of a plant with the knife, or other instrument, is practised for various purposes, but chiefly on trees, and more especially on those of the fruit-bearing kinds. Of two adjoining and equal sized branches of the same tree, if the one be cut off, that remaining will profit by the sap which would have nourished the other, and both the leaves and the fruits which it may produce will exceed their natural size. If part of a branch be cut off which would have carried a number of fruits, those which remain will set, or fix better, and become larger. On the observation of these facts is founded the whole theory of pruning; which though like many other practices of culture, cannot be said to exist very obviously in nature, is yet the most essential of all operations for the culture of fruit produced on trees.

2923. The objects of pruning may be reduced to the following: promoting growth and bulk; lessening bulk; modifying form; adjusting the stem and branches to the roots; renewal of decayed plants or trees; and removal or cure of diseases.

2924. Pruning for promoting the growth and bulk of a tree, is the simplest object of pruning, and is that chiefly which is employed by nursery-men with young trees of every description. The art is to cut off all

the weak lateral shoots, that the portion of sap destined for their nourishment may be thrown into the strong ones. In some cases, besides cutting off the weak shoots, the strong ones are shortened, in order to produce three or four shoots instead of one. In general, mere bulk being the object, upright shoots are encouraged rather than lateral ones; excepting in the case of trained trees, where shoots are encouraged at all angles, from the horizontal to the perpendicular, but more especially at the medium of 45 degrees. In old trees, this object is greatly promoted by the removal, with the proper instruments, of the dead outer bark.

2925. *Pruning for lessening the bulk of the tree* is also chiefly confined to nursery practice, as necessary to keep unsold trees portable. It consists in little more than what is technically called *heading down*; that is, cutting off the leading shoots within an inch or two of the main stem, leaving, in some cases, some of the lower lateral shoots. Care is taken to cut to a leaf bud, and to choose such from among the side, upper, or under buds of the shoot, according as the succeeding year's shoots may be wanted, in radiated lines from the stem, or in oblique lines in some places to fill up vacancies. It is evident that this unnatural operation persisted in for a few years must render the tree knotty and unsightly, and in stone-fruits, at least, it is apt to generate canker and gum.

2926. *Pruning for modifying the form of the tree embraces* the management of the plant from the time of its propagation. In rearing trees planted for timber, it is desirable to throw the timber produced, as much as possible, into long compact masses; and hence pruning is employed to remove the side branches, and encourage the growth of the bole or stem. Where this operation is begun when the trees are young, it is easily performed every two or three years, and the progress of the trees under it is most satisfactory; when, however, it is delayed till they have attained a timber size, it is, in all cases, much less conducive to the desired end, and sometimes may prove injurious. It is safer in such cases to shorten or lessen the size of lateral branches, rather than to cut them off close by the stem, as the large wounds produced by the latter practice either do not cicatrize at all, or not till the central part is rotten, and has contaminated the timber of the trunk. In all cases, a moderate number of small branches, to be taken off as they grow large, are to be left on the trunk, to facilitate the circulation of the sap and juices. Where timber-trees are planted for shelter or shade, unless intermixed with shrubs or copse, it is evident pruning must be directed to clothing them from the summit to the ground, with side branches. In avenues, and hedge-row trees, it is generally desirable that the lowest branches should be a considerable distance from the ground; in trees intended to conceal objects, as many branches should be left as possible; and in others, which conceal distant objects desired to be seen, or injure or conceal near objects, the form must be modified accordingly. In all these cases, the superfluous parts are to be cut off with a clean section, near a bud or shoot if a branch is shortened, or close to the trunk if it is entirely removed; the object being to facilitate cicatrization.

2927. *Pruning for adjusting the stem and branches to the roots* is almost solely applicable to transplanted trees, in which it is an essential operation; and should be performed in general in the interval between removal and replanting, when the plant is entirely out of the ground. Supposing only the extremities of the fibres broken off, as is the case in very small plants and seedlings, then no part of the top will require to be removed; but if the roots have been broken or bruised in any of their main branches or ramifications, then the pruner, estimating the quantity of root of which the plant is deprived by the sections of fracture and other circumstances, peculiar and general, will be able to form a notion of what was the bulk of the whole roots before the tree was undisturbed. Then he may state the question of lessening the top to adjust it to the roots, thus:—as the whole quantity of roots which the tree had before removal, is to the whole quantity of branches which it now has, so is the quantity of roots which it now has to the quantity of top which it ought to have. In selecting the shoots to be removed, regard must be had to the ultimate character the tree is to assume, whether a standard, or trained fruit-tree, or ornamental bush. In general, bearing-wood and weak shoots should be removed, and the stronger lateral and upright shoots, with leaf or shoot-eyes, left.

2928. *Pruning for renewal of the head* is performed by cutting over the stem a little way, say its own thickness above the collar, or the surface of the ground. This practice applies to old osier-beds, coppice woods, and to young forest-trees. Sometimes also it is performed on old, or ill-thriving fruit-trees which are headed down to the top of their stems. This operation is performed with the saw, and better after scarification, as in cutting off the broken limb of an animal. The live section should be smoothed with the chisel or knife, covered with the bark, and coated over with grafting-clay, or any convenient composition, which will resist drought and rain for a year. Those who are advocates for pruning when the sap is dormant, will not of course be able to perform the operation of scarification, and covering the section with bark.

2929. *Pruning for curing diseases* has acquired much celebrity since the time of Forsyth, whose amputations and scarifications for the canker, together with the plaster or composition which he employed to protect the wounds from air, are treated of at large in his *Treatise on Fruit-Trees*. Almost all vegetable diseases either have their origin in the weakness of the individual, or induce a degree of weakness; hence to amputate a part of a diseased tree is to strengthen the remaining part, because the roots remaining of the same force, the same quantity of sap will be thrown upwards as when the head and branches were entire. If the disease is constitutional, or in the system, this practice may probably, in some cases, communicate to the tree so much strength as to enable it to throw it off; if it be local, the amputation of the part will at once remove the disease, and strengthen the tree.

2930. *Mowing* is the operation of cutting down corn, grass, and other herbage crops with the scythe. It requires great force in the operator, and also a twisting motion of the body which brings almost every muscle into action, and is in short one of the most severe of agricultural labors. The chief art consists in cutting the crop as close to the surface of the ground as possible and perfectly level, pointing the swaths well out so as to leave scarcely any ridges under them. In the mowing of grain crops, such scythes as are shorter in the blade than the common ones, and to which either a cradle or two twigs of osier put semicircular-wise into holes made in the handles near the blades, in such a manner that one semicircle intersects the other, are made use of. Commonly in mowing barley, oats, or other grain, the corn is on the right hand of the workman; but M. de Lisle adopted something like the Hainault method of mowing wheat (2404.), in which the corn was at his left hand: he mowed it inwards, bearing the corn he cuts on his scythe, till it comes to that which is standing, against which it gently leans. After every mower a gatherer follows, which may be a lad, or a woman. The gatherer keeps within five or six feet of the mower, and being provided either with a hook or stick about two feet long, gathers up the corn, making it into parcels, and laying it gently on the ground; this must be done with spirit, as another mower immediately follows, and to every mower there is a particular gatherer. And to do this work properly, the mower should form but one tract with his feet, advancing in a posture nearly as if he was going

to fence, one foot chasing the other. In this manner the standing corn is mowed; and the workman should take care to have the wind at his left, as it bears the corn towards the scythe, and causes it to be cut nearer the ground. When wheat is bent, the workman takes the corn as it presents itself to him, which has the same effect as if the wind was at his left side. And when it is laid, it is more troublesome to the gatherer, because the cut corn is apt to be mixed with that which is standing; but a good mower takes the advantage of the wind, and cuts it against the way it is laid. No particular directions can be given for corn that is lodged and entangled, unless it be to take it as it is inclined, as if the wind were on the back of the mower.

2931. *The usual method of mowing grain*, is in the same manner as for grass, the scythe only having a cradle or bow fixed upon the heel of the handle (*fig.* 256.). In the "practice of most departments, the scythe is swung horizontally or nearly level, leaving the stubble of almost an even height; or if it rise on either side, forming what are called swath-balks, the butts of the swaths are suffered to rest upon them, the heads or ears of the corn falling into the hollow or close mown part of the preceding swath width. They are of course liable, in a wet season, not only to receive an undue portion of rain water, but to be fouled with the splashes of heavy showers. But in the Kentish practice, which is said to excel those of other districts, the position of the swaths is different. Here, the heads of the corn rest on the top of the swath-balk, provincially the 'beever,' which is left of extraordinary height, as ten to fifteen inches; so that the wind has a free circulation beneath the swaths. The workman, in performing this judicious operation, proceeds with his right foot forward, entering the point of his scythe with a downward stroke, and raising it as abruptly out, bringing the handle round to the left until it forms nearly a right angle with the line of the swath, carrying the corn in the cradle three or four feet behind the place where it grew, lifting it high, and letting it fall on the beever behind his left foot, and in the position above described. The disadvantages of this method are, the loss of some straw, the incumbrance arising from the length of stubble, and a little additional labor; but in a district where cattle are not numerous, the loss of straw is not felt, and in any country the principle of laying the heads, instead of the butts of the corn upon the swath-balk, whether left high or low, might be well adopted."

2932. *In the cutting of grass crops for the purpose of being converted into hay*, it is necessary that they be in the most suitable states of growth and maturity, for affording the best and most nutritious fodder. With this view they should neither be cut at too early a period, or suffered to stand too long; as in the former case there will be considerable loss in the drying, from the produce being in so soft and green a condition, and in the latter from a large proportion of the nourishing properties being expended. Grass when mown before it becomes in full flower, while the rich saccharine juice is in part retained at the joints of the flower-stems, is in the most proper condition for being cut down, as at that period it must contain the largest proportion of nutritious materials, but which then begins to be absorbed, and taken up in proportion as the flowers expand, and the seeds ripen, so as to constitute the meal or starch of the seed lobes, and is either dispersed upon the land, or fed upon by birds; the grass stems with their leaves being left in a similar situation to that of the straw of ripened grain. But there are other circumstances, besides those of ripeness, to be attended to in determining the period of cutting crops of grass, as in some cases when they are thick upon the ground the bottom parts become of a yellow color before the flowering fully takes place; under such circumstances it will often be the most advisable practice to mow as soon as the weather will possibly admit; for if this be neglected, there will be great danger of its rotting, or at any rate of its acquiring a disagreeable flavor, and of becoming of but little value. Where grass is very tall, as is often the case in moist meadows, it is liable to fall down and lodge, by which the same effects are produced.

2933. *In cutting roun or second crops of grass*, more attention will be requisite than in the first, as the crops are mostly much lighter and more difficult to cut, the scythe being apt to rise and slip through the grass without cutting it fairly, except when in the hands of an expert workman. Crops of this sort should always be cut as much as possible when the dew is upon them; and as soon as ever there is a tolerable growth, as by waiting, the season is constantly getting more unfavorable for making them into hay; and when not well made this hay is of little or no value. When the grass has been decided to be in the proper condition for being cut down, a set of mowers proportioned to the extent of the crop should be immediately provided. In some districts, it is the custom to pay these laborers by the day, but a better and more general practice is, to let the work at a certain price by the acre. The extent or proportion of ground that can be mown in any given space of time, must obviously vary much according to the nature of the ground, the fulness of the crop, and the goodness of the workman, but in general an acre is supposed a full day's work for an expert mower.

2934. *The mowing of weeds and coarse tussocks of grass in pasture* should take place before they come into flower, or at all events before they ripen their seed. Bruising or

clipping with a sort of blunt wooden shears is considered preferable for ferns, thistles, and nettles (2904.), as they are said not to spring up again the same season, which they are apt to do if cut over with the clean cut of the scythe.

2935. *The moving of weeds in rivers and ponds* is done in the usual way from a boat, in which the operator stands, and is rowed forward by another as required. Sometimes scythe-blades are tied or rivetted together, and worked by means of ropes like a saw from one shore to the other; but the first mode is generally reckoned the best, even in public canals, and is unquestionably so in agriculture.

2936. *The Hainault moving* is a process which is exclusively applicable to corn crops; it has been long practised in Flanders, and though various attempts have been made at different times and places to introduce it to this country, and notwithstanding the great advantages promised, it is still little known. It has lately been practised with success on the estate of G. H. Rose, Esq. at Muddeford, in Hampshire. We have already described the implement, and the mode of using it. The breadths of corn cut at every stroke, are carried forward by the joint operation of the blade and the hook, and collected at the left hand of the mower, where he leaves them standing almost erect, but leaning to the left against the standing corn. When as much is cut as will make a sheaf, the mower turns to the left so as to face the standing corn, introduces his hook behind the middle of the leaning parcels, and at the same time the scythe points near the bottom; then mowing sideways to the left, returning over the ground he has mown, he draws and collects the cut corn, still by means of the hook and scythe preserving the erect position of the straw to the place where the last collecting operation ended; then wheeling round to the left with the hook still embracing the middle of the whole cut corn, he stops the motion of the scythe, whilst the hook still moves forward to the left, so as to overset the corn and lay it evenly along on the stubble, with the ears towards the right, ready for the binder. In oversetting the collected corn he uses his left foot if necessary. The mower now advances to the front, and commences the cuts for a new sheaf as before, always working towards the standing corn and not from it. With the Hainault scythe, about twice as much corn, it is said, may be cut in the same time, as with the common reaping hook, and a great deal more of the straw is saved.

2937. *Reaping* is the operation of cutting corn with the hook or sickle, the former called provincially bagging, the latter shearing or reaping. The operation of reaping is most general in the northern counties. The corn is cut in handfuls with the sickle (2406.), and these are immediately deposited upon bands, formed by twisting together a few of the stalks of the corn at the ends next the ears, and afterwards bound up into sheaves, in order to their being set up into *shocks* or *hattocks*. This method is in most instances adopted with the wheat and rye crops in every part of the island, as in cutting them with the scythe it is difficult to be performed without much loss being sustained by the shedding of the grain. And in addition, it is of great advantage to have these sorts of crops bound up regularly into sheaves, the straw being much better.

2938. *In bagging*, the operator hooks up the corn towards him, and then lays it on bands as in reaping. By this mode corn is cut lower than by reaping with the sickle, but rather more straws drop unless great care is taken.

2939. *Sheaving and shocking*, or as termed in the north binding and stooking, are operations performed for the most part immediately after the corn is cut. In binding it is tied up in sheaves or bundles by the bands already mentioned; and in shocking or stooking, the sheaves are set on end in pairs leaning against each other and covered or otherwise by what are called heading sheaves, laid on the upright ones so as to cover and protect the ears from the weather, and act as a roof to the shock or stook. The number of sheaves brought together in a stook, and even the modes of placing them, vary in different districts. The operation is performed with most care and neatness in the wet climates of the north.

2940. *Gaiting* is a species of sheaving and shocking of considerable importance in late or wet climates. In performing the operation the sheaves are tied near the top, not loosely, as described by Marshal, but very tightly; the binder then takes hold of the sheaf with one hand, and with the other spreads the bottom, so that when erected it has precisely the appearance of the straw covering of a bee-hive; the top is then compressed to exclude the rains. When the single sheaves (gaitics) have remained in this position for a few days, if the weather is unpromising, they are formed into very small ricks of a conical figure, tapering, however, but little till near the top. When the sheaves are piled up successively in building, the butt-ends are carefully spread so as to cover completely the ears, and thus serve as thatch for the sheaves underneath. A large sheaf is used for the hood, put on in the same way as in a common stack. The little building is then secured with a rope, and the grain thus thatched with its own straw bids defiance to the heaviest rains.

2941. *In the reaping of grain crops*, whether the sickle, hook, or scythe be employed for the purpose, there is much difference in the height at which the crops are cut in different

places. In some it is the practice to have the business performed in as close a manner as possible; while in others a stubble of eight, ten, and fifteen inches or more is left. These different practices having their advocates, one party supposing that the work proceeds more slowly where it is executed in so close a manner, while the other contend that the contrary is the case. But as the stubble which is left is not only useless to the land, but in many cases very troublesome in its succeeding culture, being frequently under the necessity of being removed, it would seem to be the best as well as cheapest practice, to have the business constantly executed in a close manner. By this means the agricultor will not only have more litter at command for the bedding of his yards, stalls, and other places, and consequently an increase of manure, but with much less waste of grain, and at the same time be freed from the trouble and expense of removing the stubble. It has, indeed, been fully shown, by a careful trial, made with the view of ascertaining the difference between high and low reaping, that the advantage is considerably in favor of the latter.

2942. *The use of the sickle and the scythe in reaping grain crops* have each their advantages and disadvantages. In the first manner, the crops are deposited with more regularity and exactness, and consequently bound into sheaves with greater facility and despatch. Besides, in many cases less loss is incurred by the shedding of the grain in the time the work is performing; but the labor is executed with greater difficulty and trouble. The latter possesses the superiority of being more expeditious, and of being performed to any degree of closeness that may be required; while it has the evident disadvantage of leaving the cut grain in a more irregular and uneven situation, by which it is rendered less fit for being bound up into sheaves, which in many cases is an inconvenience of great consequence. When the grain has attained a high degree of ripeness, there may, likewise, be great loss sustained, by its being shed during the operation, in this way of reaping or cutting the crop. Where this method is practised, it is, however, not unfrequently the case to have it bound into sheaves, though the more common custom is to let it remain in the rows or swaths till fit for being put into the stack. When bound, it is generally the practice to cut it inwards against the crop on which it rests. In the other case, it is cut in the manner of grass for hay. It is obvious, therefore, that where operators are procured with difficulty, this mode of reaping is the most advisable, while under the contrary circumstances, the former may be had recourse to with more advantage, as the work may be executed in a neater and more exact way.

2943. *Reaping, whatever mode be adopted, is often let by the acre* to persons that go about for harvest work, and it may, in many cases, be best performed in this manner; but great attention should be paid by the cultivator to see that the grain is cut and bound up in a proper method, and that the work be not performed in improper weather. The prices vary according to the nature of the crops, the season, and other circumstances.

2944. *Pulling* is a mode of taking a crop, applicable chiefly to flax and hemp. These are pulled in handfuls, the earth beat and shaken from their roots, and after the handfuls have lain a day or more separately, they are collected together and tied in bundles. In the case of hemp, it being a dioecious plant, the male stalks are pulled some weeks before the others. Dry weather is preferable for the operation.

2945. *Digging up or forking up*, is occasionally resorted to for taking crops of roots, as potatoes, carrots, &c. In performing this operation, the principal thing is to avoid cutting or bruising the roots with the spade or fork, and to separate the roots from the soil by first lifting up the spitful and then throwing it down in such a way as to break and scatter it, and bring to light the roots or tubers. When crops of this sort are planted in rows, they are frequently raised by a plough, the coulter being withdrawn.

#### SECT. IV. *Mixed Operations performed by Manual Labor.*

2946. *The mixed agricultural operations* differ little from the last as to the skill or strength required in the operator: they are chiefly ropemaking, thatching, turning straw or hay, drawing or sorting straw, flail-threshing, hedging and ditching, weighing, measuring, stack-building, sheep-shearing, paring and burning turf, burning clay, and forming compost soils or manures.

2947. *Strawrope making* is an operation which requires two persons when performed in the usual manner with a crook (2396.). In this case the person who forms the rope is stationary, and the twister moves from him backwards the length of the rope; but if the crook is turned by machinery, as for example, by a movement from a thrashing machine, or by a detached machine turned by hand (2457.), then the person who forms the rope moves backwards as he lets out the material to be twisted. These sorts of ropes are commonly made of oat or rye straw; but they are also formed of coarse hay or rushes, long moss, ferns, &c. In all cases the material requires to be moistened and thoroughly mixed together before made use of by the ropemaker.

2948. *Thatching* is the operation of covering the roofs of buildings, stacks, &c. with some sort of thatch. It is an art that requires considerable care, attention, and practice



to perform it in a proper manner. Before this business is begun, it is necessary that the materials of whatever kind they may be, should undergo some preparation. With articles of the straw kind the usual method is this: the substances after being well moistened with water, are drawn out in handful perfectly straight and even, into regular lengths, and the short straw separated from them, leaving them placed in convenient bundles to be carried to the thatcher by the person who has the serving of him.

2949. *The application of thatch to stacks of hay or corn*, is performed by different methods, according to the nature of the materials employed. Where long straw is made use of, the operator or workman usually begins at the eaves or bottom of the roof, depositing it in handful in regular breadths till he reaches the top, the different handful being so placed endways as to overlap each other, the upper ends being constantly pushed a little into the bottom parts of the sheaves. In this manner he gradually proceeds breadth after breadth till the whole of the roof is covered, which is usually done to the thickness of about four or five inches. And in order to retain the thatch in its place, short sharp pointed sticks are sometimes thrust in, in a slanting direction upwards, and sometimes small sticks sharpened at the ends are bent and thrust in along the top parts and sides. But as the water is apt to follow the course of the sticks, it is a better practice to make use of ropes of twisted straw for this purpose. In some cases these are applied only round the bottom parts of the roof and the sides; while in others, which is a much better and more secure method, they are applied in such a manner over the whole stacks as to form a sort of net or lozenge-work of nine or twelve inches in width in the meshes (*fig. 413.*), the ends being well fastened either to the sides of the stack under the eaves, or to a rope carried round in that situation on purpose to fasten them to. This method of tying on the thatch should always be had recourse to where the stackyards are greatly exposed to the effects of wind, as without such precautions much injury and loss may frequently be sustained by the farmer. It is in common use in Northumberland and northwards.



413

2950. *In the application of stubble as a thatch for ricks* it is mostly put on by sticking one of its ends into the roof of the stack in a regular and exact manner, so as that it may stand very close and thick; when the other, with such loose straws as may occur, is to be cut over or pared off with the thatching knife, or a very sharp tool for the purpose, so as to form a neat and impenetrable thatch, having the appearance of a newly thatched house roof (*fig. 414.*); the whole being well secured in its place by short pegs made for the purpose, somewhat in the same way as in the other stacks.

414



2951. *The time of commencing the thatching of hay and corn stacks* should be delayed until they have fully settled, as under the contrary circumstance it is sure to rise into ridges afterwards, and by that means admit the water to pass down into them, and of course do much injury to the corn or hay.

2952. *In the thatching of the roofs of houses or other buildings* with any of the sorts of straw, the same rules are in some respects to be followed, only the materials are to be laid on to a considerable thickness and be more firmly secured. They are applied in regular narrow slips, or what in some districts are termed *gangs*, from the eaves of the building to the ridges, the ladder being moved forward as the work proceeds. The thatch is secured by short sharpened sticks thrust in where necessary. And bended sticks sharpened at each end are likewise sometimes made use of near the ridges, being thrust in at each end. In finishing the work, the thatcher employs an iron-toothed rake, with which the whole is raked over from the top to the bottom, so as to render it completely smooth and even, and take away all the short straws.

2953. *The method of thatching with reed*, according to Marshall, who seems to have paid much attention to the subject, in his account of *The Rural Economy of Norfolk*, is this: "No laths being made use of, in laying it a little of the longest and stoutest of the reed is scattered irregularly across the naked spars, as a foundation to lay the main coat upon: this partial gauze-like covering is called the '*fleaking*.'"

2954. On this *fleaking* the main covering is laid, and fastened down to the spars by means of long rods — provincially, "*sways*," — laid across the middle of the reed, and tied to the spars with rope yarn, or with "*bramble bonds*," which formerly were much in use, but which are now nearly laid aside, especially for new roofs.

2955. *Reed is not laid on in longitudinal courses*, in the manner that straw thatch is usually put on, nor is the whole eaves set at once. The workman begins at the lower corner of the roof, on his right hand for instance, and keeps an irregular diagonal line or face, until he reach the upper corner to his left, a narrow eaves-board being nailed across the feet of the spars, and some *fleaking* scattered on; the thatcher begins to "*set his eaves*," by laying a coat of reed, eight or ten inches thick, with the heads resting upon the *fleaking*, and the butts upon the eaves-board. He then lays on his *sway* (a rod rather thicker than a large withy), about six or eight inches from the lower points of the reeds; whilst his assistant, on the inside, runs a needle, threaded with rope yarn, close to the spar; and in this case, close to the upper edge of the eaves-board. The thatcher draws it through on one side of the *sway*, and enters it again on the contrary side, both of the *sway* and of the spar: the assistant draws it through, unthreads it, and with the two ends of the yarn, makes a knot round the spar, thereby drawing the *sway*, and

consequently the reed right down to the roof; whilst the thatcher above, beating the sway and pressing it down, assists in making the work the firmer. The assistant having made good the knot below, he proceeds with another length of thread to the next spar, and so on till the sway be bound down the whole length; namely, eight or ten feet. This being done, "another stratum of reed is laid on upon the first, so as to make the entire coat eighteen or twenty inches thick at the butts; and another sway laid along, and bound down, about twelve inches above the first."

2956. *The eaves* are adjusted and formed, not square with the spars, but nearly horizontal; nor are they formed by cutting; but by "driving" them with a "*legget*," a tool made of a board eight or nine inches square, with a handle two feet long, fixed upon the back of it, obliquely, in the manner of the tool used by gardeners in beating turf. The face of the *legget* is set with large headed nails to render it rough, and make it lay hold of the butts of the reeds. Then another layer or reed is laid on, and bound down by another *sway*, somewhat shorter than the last, and placed eighteen or twenty inches above it; and above this another, and another, continuing to shorten the sways until they be brought off to nothing, and a triangular corner of thatching formed. After this, the sways are used their whole length, whatever it happens to be, until the workman arrives at the finishing corner. By proceeding in this irregular manner seams between the courses are prevented, and unnecessary shifting of ladders avoided.

2957. *The face of the roof* is formed and adjusted like the eaves, by driving the reed with the *legget*; which operation, if performed by a good workman, not only gives the roof a beautiful polished surface, but at the same time fastens the reed, which being thickest towards the butts, becomes like a tapering pin, the tighter the farther it is driven.

2958. *Finishing the ridge of the roof.* In the case of reed running from four to six or eight feet long, the heads meet at the ridge of the roof, whilst the butts are still at a distance from each other. For this reason, as well as for that of the wear being less towards the ridge, the shortest (which is generally the worst) reed is saved for the upper part of the roof. But even supposing the uppermost courses to be only four feet long, and that the heads (belonging to the two sides) be interwoven in some degree with each other, the butts will still remain six or seven feet asunder; and the ridge of the roof consequently be left in a great measure exposed to the weather. In order to remedy this inconvenience, and to give a finish to the ridge, a *cap*—provincially a "*roof*" of straw is set on in a masterly, but in an expensive manner. In this operation, the workman begins, it is observed, by bringing the roof to an angle, with straw laid long-way upon the ridge, in the manner in which a rick is topt up; and to render it firm, to keep in its place, and to prevent the wind from blowing it off, or ruffling it, he pegs it down slightly with "double broaches;" namely cleft twigs, two feet long, and as thick as the finger, sharpened at both ends, bent double, and perhaps with the twisting the crown, and perhaps barbed, by partial chops on the sides, to make them hold in the better. This done, the workman lays a coat of straight straw, six or eight inches thick across the ridge, beginning on either side at the uppermost butts of the reed, and finishing with straight handfuls evenly across the top of the ridge. And having laid a length of about four feet in this manner, he proceeds to fasten it firmly down, so as to render it proof against wind and rain. This is done by laying a "*broachen ligger*," (a quarter-cleft rod as thick as the finger, and four feet in length) along the middle of the ridge, pegging it down at every four inches with a double broach, which is thrust down with the hands, and afterwards driven with the *legget*, or with a mallet used for this purpose. The middle ligger being firmly laid, the thatcher smooths down the straw with a rake and his hands, about eight or nine inches on one side, and at six inches from the first, lays another ligger, and pegs it down with a similar number of double broaches, thus proceeding to smooth the straw, and to fasten on liggers at every six inches, until he reach the bottom of the cap. One side finished, the other is treated in the same manner; and the first length being completed, another and another length is laid, and finished as the first; until the other end of the ridge be reached. He then cuts off the tails of the straw square and neatly with a pair of shears, level with the uppermost butts of the reed, above which the cap (or most properly the *rooflet*) shows an eaves, of about six inches thick; and, lastly, he sweeps the sides of the main roof with a bough of holly; when the work is completed.

2959. *Trussing straw or hay* is the operation of binding it in bundles for more convenient deportation. In trussing hay from a rick it is cut into cubic masses with the hay knife (2408.), and tied by a hay rope passing once across each of its sides. If the trusses are intended for the market, they are weighed with a steelyard, and each truss of old stacked hay must weigh 56 pounds, and of new hay, during June, July, and August 60 pounds.

2960. *Straw is commonly trussed* by tying it into bundles by a band of a handful of straws, or a short rope across the middle of the bundle, or by a particular mode of twisting and turning back the two straggling ends of a loose armful of straw, and tying these ends in the middle. This mode, easier practised than described, is termed in the north bottling or windling. When wheat straw or any other sort is to be trussed for thatch, it is first drawn into regular lengths leaving out the refuse as already alluded to under thatching. In London, the straw sold for litter is always required to be trussed in this manner, and each truss is required to weigh 56 pounds.

2961. *Threshing by the flail* is still a very general practice in most of the southern counties, though all the intelligent men agree that it is more expensive and less effectual than threshing by a machine. Even on the smallest sized farms where a horse machine would be too expensive, either the hand machine, or portable machine (2453.) might be employed. Besides threshing cleaner, and that too in a manner independently of the care of the operators, the work is performed without the aid of expensive threshing floors, goes on rapidly, is a more agreeable description of labor for servants, employs women and children, and, finally, exposes the corn to less risk of pilfering.

2962. *In the flail mode of threshing*, the produce is constantly exposed to the depredations of the persons that are employed in executing the business, which is a great objection, and in many cases proves a source of great loss to the farmer, as he cannot by any means prevent the impositions to which it is liable. It has been observed by Middleton, in his *Survey of Middlesex*, that "where threshers are employed by the day, they frequently do not perform half the work that ought to be done in the time, nor even that in a perfectly clean manner." And that "it be executed by the quarter, or by the truss, the freest corn is threshed out, and the rest left in the ear." The same thing takes place in a greater or less degree in every other mode that can be devised for having the work performed by the hand; and it is consequently only by the general introduction and use of the threshing machine that the property and interest of the farmer can be fully secured, and work be executed with a proper degree of economy.

2963. *In respect to the mode of threshing corn by the flail*, it is the practice in some districts for only one person to be employed upon a floor, but as two can thresh together with equal if not greater expedition and dispatch, it must be an ineconomical and disadvantageous mode. But where more than two laborers

thresh together, which is sometimes the case, there must be frequent interruptions, and a consequent loss of time. The flail or tool by which this sort of business is performed should be well adapted to the size and strength of the person who makes use of it, as when disproportionately heavy in that part which acts upon the grain, it much sooner fatigues the laborer, without any advantage being gained in the beating out of the grain. The best method of attaching the different parts of the implement together is probably by means of caps and thongs of good tough leather. Iron is however sometimes employed. In threshing most sorts of corn, but particularly wheat, the operators should wear thin light shoes, in order to avoid bruising the grains as much as possible. In the execution of the work, when the corn is bound into sheaves, it is usual for the threshers to begin at the ear-ends, and proceed regularly to the others, then turning the sheaves in a quick manner by means of the flail, to proceed in the same way with the other side, thus finishing the work.

2964. *The quantity of corn that a laborer will thresh with the flail in any given period of time, must depend on the nature of the grain, the freeness with which it threshes, and the exertions of the laborer; in general it may be of wheat, from one to one and an half quarter, of barley from one and a half to two quarters; and of oats mostly about two in the day.* The exertions of laborers in this sort of work in the northern districts of the kingdom are however much greater than in those of the south; of course a much larger proportion of labor must be performed. In some places it is the practice to thresh by the measure of grain, as the bushel, quarter, &c., while in others it is done by the threave of twenty-four sheaves, and in some by the day. In whatever way the agricultor has this sort of business performed, there is always much necessity for his constant inspection, in order to prevent the frauds and impositions that are to frequently practised upon him by the persons engaged in the execution of it.

2965. *The practice of whipping out grain* is resorted to in some districts with wheat when the straw is much wanted for thatch. The operator takes a handful and strikes the ears repeatedly against a stone, the edge of a board, or the face of a strong wattled hurdle, till the corn is separated.

2966. *Rippling* is the operation of separating the bolcs or seed pods of flax and hemp by striking in the manner of whipping, or more commonly by drawing them through an implement of the comb kind, constructed with several upright triangular prongs set near together in a strong piece of wood.

2967. *Hedging and ditching*, the operation of making and mending fences and open water-courses of the different kinds already enumerated, consists of the combined application of digging, shovelling, cutting, clipping, and faggoting, described in this and the two foregoing Sections.

2968. *Faggoting* is a term applied to the dressing or binding of the prunings or superfluous branches and spray of hedges. The bundles are made of different sizes in different parts of the country, and in the same place according to the purpose to which they are to be applied. They are tied with willow, hazel, or some other pliable wood twisted before application.

2969. *Stacking wood for fuel*, occurs in the practice of common agriculture when hedges and pollard trees or tree-roots are stocked or dug up. The wood, whether roots or trunk, is cut into lengths of from eighteen inches to two feet with a saw, then split with iron wedges into pieces of not more than one and a half, or two inches in diameter, and built into an oblong stack generally three feet broad and high, and six feet long.

2970. *Stacking wood for burning, stewing for tar*, or pyrolignous acid, charring, and similar purposes, is peculiar to forest culture, and will be treated of in the proper place. (See Part III. or *Index*.)

2971. *Paring and burning* is the process of paring off the surface of lands in a state of grass, in order to prepare them for arable culture by means of fire. In the method of performing the process, there is some slight difference in the practice of different districts, and an attention to the nature of the lands is as necessary as in other cases of husbandry. It would seem that some soils, as those of the more clayey and heavy kinds, would be most benefited by having the fire to come as much as possible into contact with the whole of the superficial parts of them, without being carried too far, as by that means they may be rendered more proper for the reception of the roots of vegetables after being slightly ploughed, as well as more suitable for supplying nourishment to them; while in others, as those of the more light and thin description, it might be most advantageous merely to consume the thin paring of sward after being piled up for the purpose; without permitting the fire to exert its influence upon the mould or soil immediately below, as in this way there would not probably be so much danger of injuring the staple by destroying the vegetable matters contained in such soils. Of course, in the first of these modes of burning the sward, the sods or parings should be piled up as little as possible into heaps, the advantage of a suitable season being taken to apply the fire to them in the state in which they lie, or are set at first after being cut up, or after a few only have been placed together, as happens in some instances where they are, immediately after being cut, set on edge to dry, and placed in serpentine directions, in order to prevent them from falling over; but in the latter cases they should be formed or built up into little circular heaps or piles, somewhat in the form and size of the little cocks made in hay-fields, the sods being placed the grass-side downwards, in order to admit air: but the openings both at the bottoms and tops, after they have been fully set on fire by some combustible substance, such as straw, &c. are to be closed up, as well as those in other parts covered by an addition of sods; so as that the combustion may proceed in a slow, smothering manner, such as is practised in the making of char-

coal. When the whole of the earth in each of the piles has been acted upon by the fire, the heaps may be suffered to extinguish themselves by slowly burning out.

2972. A variety of this operation, called *skirting* or *peat burning*, is practised in Devonshire and Cornwall, for breaking up and preparing grass lands for the reception of fallow crops; a part of the sward or surface is alternately left unturned, upon which the next thin furrow slice is constantly turned, so that the swards of each come in contact, by which means the putrefactive fermentation is speedily excited, and the greatest part of the grassy vegetable matter converted into manure; what ultimately remains undestroyed being, after repeated cross-cuttings with the plough, and harrowings, collected into small heaps and burnt, the ashes being then spread evenly over the land.

2973. With respect to the *implements used in paring*, different kinds are made use of in different parts of the island: that which was the most employed in the infancy of the art, was a kind of curved mattock or adze, about seven or eight inches in length, and five or six in breadth; and which, from its shape, would appear to have been better adapted for cutting up the roots of brush-wood, furze, broom, or other coarse shrubs, than for paring off the surface of a field free from such incumbrances. Where the sod is pared off by manual labor, the ordinary breast-spade, in some places called the breast-plough, and in Scotland the slaughter-spade (2378.), is mostly employed. In working the tool, the laborer generally cuts the sods at about an inch or an inch and a half thick, and from ten to twelve broad; and when the spade has run under the sod to the length of about three feet, he throws it off, by turning the instrument to one side, and proceeds in the same way, cutting and throwing over the sods, the whole length of the ridge. In this way of performing the operation the laborers, by following each other with a slice of the sward or surface of the land, accomplish the business with much ease, and in an expeditious manner.

2974. In the *fenny districts*, on the eastern coasts, where paring and burning is practised on a large scale, the horse-paring plough is used, made of different constructions, according to the circumstances of the ground to be pared. These ploughs (*fig. 415.*) are calculated for paring off the sward or sod of such grounds as are level, and where neither stones, brush-wood, ant-hills, nor other impediments obstruct their progress; but where such obstructions present themselves the breast-spade, or the common team-plough, with a small alteration of the share, will be found preferable, both in respect to the extent of ground that can be pared, and the superior manner in which the work in such cases can be performed. Ploughs, from their great expedition and regularity of performing the business, should always be made use of where the nature and situation of the land will admit them, in preference to such tools as require manual labor.

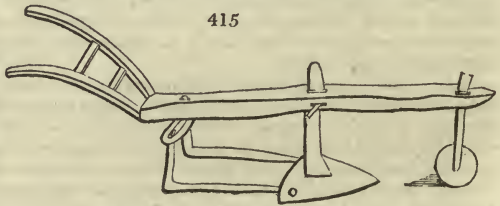

2975. In some of the *western counties*, the common plough only is used. There the old grass fields, when it is proposed to burn the sward, are rib or slob furrowed about the beginning of winter; and being again cross-ploughed the following spring, the sods are collected and managed in the manner mentioned in speaking of skirting. In those cases the plough has, however, a wing turned up on the furrow side of the plough-share, by which the furrow is cut any breadth required.

2976. The season for paring and burning is April, May, and June: the particular period must, however, always depend much on the state of the weather and the nature of the crop. When the east winds prevail, in February and March, this sort of business may sometimes be carried on. But for accomplishing the work with the greatest dispatch, and also with the least trouble and expense, a dry season is obviously the best. The prudent cultivator should not embark in the undertaking, unless there be a reasonable probability of his accomplishing it while the weather keeps dry and favorable. The latter end of May or the beginning of June, when the hurry of the spring-seed time is over, in the more northern districts, when a number of hands can be most easily procured may, upon the whole, be considered as the best and most convenient season; as at this period the green vegetable products are in their most succulent state, and of course may probably afford more saline matter; but in the more southern counties either a much earlier season must be taken, or the interval between the hay season and the harvest time must be fixed upon, the latter of which is, on the principle just stated, evidently the best, where the extent of ground to be burnt is not too large. In other seasons it would frequently be impossible to procure a sufficient number of hands for performing the business. In bringing waste lands into cultivation, where an extensive tract of ground is to undergo this process, the autumn may, in many cases, afford a convenient opportunity

for the operation. A good deal depends on the crops that are to be sown after paring and burning. When rape or turnips are to be cultivated, the end of May, or the beginning of June, will be the most proper time: but if barley or oats are to be sown, the paring and burning must be completed as early in spring as the nature of the season will admit; and when lands are pared and burned as a preparation for a crop of wheat, July, or even the beginning of August, may, in favorable seasons, answer; but it is better to have the ground ready sooner if possible.

2977. In respect to the depth to which lands of different qualities may be pared with the most advantage, it is obvious that, as it can hardly be proper to pare light, thin, stapled soils, to the same depths as those of the more deep and heavy kinds, it should, in some degree, be regulated by their particular nature, and their differences in respect to depth and heaviness. Boys, who is in the habit of breaking up thin chalky soils, and such as have been in tillage, in this way, observes, that in Kent, where the method of paring most in use is with *down-shares* or breast-ploughs, they take off turfs as thick as the nature of the soil will admit, from half an inch to two inches; the thicker the better, provided there be a sufficient portion of vegetable matter contained within them to make them burn well. The most usual depths of paring are, from about one to three inches.

2978. In regard to *burning*, when the season is not very wet, the turfs will commonly be sufficiently dried in about a fortnight or three weeks, even without being turned; but in rainy weather they require a longer time, and must be turned more than once to prevent their striking out roots and shoots, which might hinder them from burning.

2979. *Spreading the ashes.* As soon as the turfs have fully undergone the process of burning, and are reduced to the state of ashes and a powdery earthy matter, the whole should, as soon as possible, be spread out over the land in as regular and equal a manner as the nature of the work will admit of; for without great attention in this respect, great inequality in the crops may take place; besides the soil will be made lighter in some places than in others, which may be disadvantageous in the same way. The spreading, where it can by any means be accomplished, should always be performed before any rain falls; as where this point is not attended to, a great loss may be sustained by the saline matters being carried down in a state of solution, and their beneficial effects in a great measure lost before the crops are in a condition to receive them. In order to secure the full influence of the ashes, the land is frequently slightly ploughed over immediately after the ashes are spread out. And it is stated by Donaldson, that those who are more than ordinarily attentive in this respect, only rib or slob furrow the field, so that the ashes after burning may be covered up with the greater expedition and dispatch. By this mode they cannot probably, however, be so equally mixed with the soil as by that of ploughing the whole field with a very slight furrow, so as just to cover them.

2980. *The expense of the operation of paring and burning* will vary according to the nature and situation of the land, the method in which it is performed, and the customs of the district in regard to the price of labor. On the thin sort of chalky soils it is stated by Boys, that the expense for paring at a moderate thickness, where the land is not very flinty, is about equal to four or five ploughings.

2981. *The operation of drying and burning clay for manure* is in several respects similar to that of paring and burning the verdant surface. The practice of burning clay has at various times been pursued with energy and success, and at other times has fallen into neglect. The oldest book in which it is mentioned is probably *The Country Gentleman's Companion*, by Stephen Switzer, Gardener, London, 1782. In that work it is stated, that the Earl of Halifax was the inventor of this useful improvement; and that it was much practised in Sussex. There are engravings of two kilns for burning clay, one adopted in England, and the other in Scotland; where it is said to have been ascertained, that lands reduced by tillage to poverty, would produce an excellent crop of turnips, if the ground were ploughed two or three times, and clay ashes spread over it. In the same work, there are several letters, written in the years 1730 and 1731, stating, that the plan of burning clay had answered in several parts of England; and accounts were received from Scotland, that upon experiment it had answered better than either lime or dung, but was found too expensive. The practice is described at length in Ellis's *Practical Farmer, or Hertfordshire Husbandman*, 1732. In 1786, James Arbuthnot, of Peterhead, tried several successful experiments with burning clay, and various others have since been made in different parts of the empire. In 1814, the practice was revived and written on by Craig, of Cally, near Dumfries, and soon after by General Beatson, near Tunbridge; by Curwen, Burrows, and several correspondents of agricultural journals. In Ireland, it would appear, the practice prevails in several places, and Craig says, he adopted it from seeing its effects there. The result of the whole is, that the benefits of this mode of manuring have been greatly exaggerated; though they certainly appear to be considerable on clayey soils. Aiton (*Farmer's Mag.* vol. xxii. p. 423.) compares this rage for burning clay, which existed in 1815, to the florin mania of a few years prior date. In 1822, he found few of the advocates for these

improvements disposed to say much on the subject, and saw very few clay kilns smoking. "To give my ultimatum upon this subject," he says, "I regret that the discoverers of forin grass, and of the effects of burnt clay, have so far overrated their value. Both are useful and proper to be attended to; — the grass to be raised on patches of marshy ground, and used as green food to cattle in winter; and the burnt earth as a corrector of the mechanical arrangement of a stubborn clay soil; and I have no doubt, but if they had been only recommended for those valuable purposes, they would have been brought into more general use than they yet are, or will be, till the prejudice against them, arising from the disappointment of expectations, raised high by too flattering descriptions, are removed."

2982. *The action of burnt clay on the soil*, is thus described by the same author. "It must be obvious to every person that has paid attention to the subject, that when clay, or other earth, is burnt into ashes like brick-dust, it will not (unless acids are applied to it) return again to its former state of clay, but will remain in the granulated state of ashes or friable mould, to which it was reduced by the operation of burning. An admixture of that kind, with a strong adhesive clay, must evidently operate as a powerful manure, by changing the mechanical arrangement of the latter, and rendering it more friable; giving greater facility to the protection of redundant moisture, and to the spreading of the roots of vegetables in quest of food. The application of as much water, sand, or any similar substance, would have exactly the same effect in opening, and keeping open, the pores of an adhesive clay soil, and converting it into the quality of loam. Besides this, which would be a permanent improvement upon the staple or texture of every clay soil, burnt clay or torrefied earth may sometimes acquire, in that operation, a small quantity of soot or carbonic matter, that may, in favorable circumstances, operate for one season as a manure, or as a stimulus to a small extent, to the growth of vegetables. This at least may be the case, if the clay or earth burnt shall abound with vegetable matter, and if the burning is conducted in such a smothered way, as to prevent the smoke or vegetable matter from escaping. But as it is the subsoil that is recommended, and seems to be generally used for burning, it is impossible any considerable quantity of vegetable matter can be found in it.

2983. *The calcareous matter in the soil*, it is said, will be calcined and formed into lime by the operation of burning. But, I am disposed to consider this argument as far more plausible than solid. Calcareous matter is no doubt found, on chemical analysis, to a certain extent in some soils; perhaps some perceptible portion of it may be found in every soil. But it is seldom or never found in any soil, to such an extent as to be of much use as a manure to other land. Even where the soil is impregnated with a large portion of calcareous matter, if it is not in the form of limestone, but minutely mixed with it, the burning cannot either increase or much alter the lime. If it is in the form of stones, however small, or in what is called limestone gravel, there is little chance of its being calcined in the operation of burning the clay; it would go through that ordeal unaltered. Any change, therefore, that can be made upon the small portion of calcareous matter in the soil by burning in the manner directed, can scarcely have any perceptible effect, when that matter is applied as manure to other soils. And though it is possible that some qualities in particular soils, unfavorable to vegetation, may be corrected by burning, and that in some other instances the fire may render the clay more nutritive to plants (though I have not been able to trace this, or even to conjecture how it can happen), yet I am much disposed to believe, that its effect as a mechanical mixture in opening the pores of the soil, is the chief improvement that can be derived from the application of burnt clay as a manure. If it has any other effect, it must be from the soot or carbonic matter collected during the operation of burning; or perhaps it may acquire by the torrefaction something of a stimulating quality, that may for a short time promote the growth of particular plants, but these qualities can only be to a small extent, and continue to act for a very limited period. (*Far. Mag.* xxii. 422.)

2984. *The action of burnt clay*, according to a writer in *The Farmer's Journal*, is at least three-fold, and may be manifold. It opens the texture of stubborn clays, gives a drain to the water, spiracles to the air, and affords to the roots facility of penetrating. Clay ashes burned from turves, containing an admixture of vegetable matter, consist, in some small proportion, of vegetable alkali, or potass, a salt which is known to be a good manure. It also, in most cases, happens, that a stiff cold clay is impregnated with pyrites, a compound of sulphuric acid and iron. Although the chemical attraction between these two bodies is so strong, that it is one of the most difficult operations in the arts totally to free iron from sulphur, yet a very moderate heat sublimes a large portion of the sulphur. The iron is then left at liberty to re-absorb a portion of the redundant sulphuric acid, which too generally is found in these soils, and thereby sweetens the land; and it is probable, that the bright red, or crimson calx of iron, which gives coloring to the ashes when over burnt, is beneficial to vegetation in the present case, inasmuch as it is, of itself, one of the happiest aids to fertility, as is exemplified in the red marl strata, and red sand strata throughout the kingdom. The evolution and recombination of different gases, no doubt, materially affect the question; but it is reserved for accurate chemical observers to give us an account of the processes which take place in this respect. Curwen notices, that clay ashes do no benefit as a top-dressing on grass, which is in part to be explained by reason that the ashes, when spread on the surface of the grass, cannot exert the mechanical action on the soil in the ways enumerated. Neither can the calx of iron come so immediately in contact with the particles of the soil, for the producing of any chemical effect, as it would do if the ashes were ploughed

in. In short, like many other manures which are laid on the surface, unless it contains something soluble which may be washed into the ground by rains, it does very little good; and the feeble proportion of vegetable alkali is probably the only soluble matter the ashes contain. However sanguine may be the admirers of burnt clay, all experience confirms, that the most beneficial clay-ashes are those which are burnt from the greatest proportion of rich old turf, ancient banks, roots of bushes, and other vegetable matters; and I conceive the value of mere powdered pottery (for such it is) may easily be over-rated. (*F. Journ.* 1819.)

2985. *The common method of burning clay* is to make an oblong enclosure, of the dimensions of a small house (say 15 feet by 10) of green turf sods, raised to the height of  $3\frac{1}{2}$  or 4 feet. In the inside of this enclosure, air-pipes are drawn diagonally, which communicate with holes left at each corner of the exterior wall. These pipes are formed of sods put on edge, and the space between these so wide only as another sod can easily cover. In each of the four spaces left between the air-pipes and the outer wall, a fire is kindled with wood and dry turf, and then the whole of the inside of the enclosure or kiln filled with dry turf, which is very soon on fire; and on the top of that, when well kindled, is thrown the clay, in small quantities at a time, and repeated as often as necessary, which must be regulated by the intensity of the burning. The air-pipes are of use only at first, because if the fire burns with tolerable keenness, the sods forming the pipes will soon be reduced to ashes. The pipe on the weather side of the kiln only is left open, the mouths of the other three being stopped up, and not opened, except the wind should veer about. As the inside of the enclosure, or kiln, begins to be filled up with clay, the outer wall must be raised in height, always taking care to have it at least 15 inches higher than the top of the clay, for the purpose of keeping the wind from acting on the fire. When the fire burns through the outer wall, which it often does, and particularly when the top is overloaded with clay, the breach must be stopped up immediately, which can only be effectually done by building another sod wall from the foundation, opposite to it, and the sods that formed that part of the first wall are soon reduced to ashes. The wall can be raised as high as may be convenient to throw on the clay, and the kiln may be increased to any size, by forming a new wall when the previous one is burnt through.

2986. *The principal art in burning* consists in having the outer wall made quite close and impervious to the external air, and taking care to have the top always lightly, but completely covered with clay; because if the external air should come in contact with the fire, either on the top of the kiln, or by means of its bursting through the sides, the fire will be very soon extinguished. In short, the kilns require to be attended nearly as closely as charcoal pits. Clay is much easier burnt than either moss or loam; — it does not undergo any alteration in its shape, and on that account allows the fire and smoke to get up easily between the lumps; whereas moss and loam, by crumbling down, are very apt to smother the fire, unless carefully attended to. No rule can be laid down for regulating the size of the lumps of clay thrown on the kiln, as that must depend on the state of the fire; but I have found every lump completely burnt on opening the kiln; and some of them were thrown on larger than my head. Clay, no doubt, burns more readily if it be dug up and dried for a day or two before it be thrown on the kiln; but this operation is not necessary, as it will burn though thrown on quite wet. After a kiln is fairly set a going, no coal or wood, or any sort of combustible is necessary, the wet clay burning of itself, and it can only be extinguished by intention, or the carelessness of the operator, — the vicissitudes of the weather having hardly any effect on the fire, if properly attended to. It may, perhaps, be necessary to mention, that when the kiln is burning with great keenness, a stranger to the operation may be apt to think that the fire is extinguished. If, therefore, any person, either through impatience, or too great curiosity, should insist on looking into the interior of the kiln, he will certainly retard, and may possibly extinguish the fire; for, as before mentioned, the chief art consists in keeping out the external air from the fire. Where there is abundance of clay, and no great quantity of green turf, it would perhaps be best to burn the clay in draw-kilns the same as lime.

2987. *An improved method of burning clay* has been adopted by Colonel Dickson, at Hexham, and other gentlemen, in Northumberland. Instead of building a kiln, gratings or arches of cast iron are used to form a vaulted funnel for the fuel, and over this funnel the clay is built. The grated arches are made about two feet and a half long, two feet diameter, and about fourteen inches high. One grating is to be filled with brushwood, stubble, or any other cheap fuel, and the clay as it is dug, built upon it to a convenient height, leaving small vacancies, or boring holes, to allow the heat to penetrate to the middle and outer parts of the clay. When a sufficient quantity is built upon the first grating, another is added at either or both ends, filled with similar fuel, and the clay built upon them as before. This process is continued until 10, 12, or a greater number, of the gratings have been used, when one end is built up or covered with clay, and at the other, under the last grating, a fire is made of coals or faggot wood. The end at which the

fire is made should face the wind if possible, and if the process has been properly conducted the clay will be effectually burnt. By commencing with a centre grating in the form of a cross (fig. 416.), the workman may build from four ends in the place of two; this contrivance will afford a facility in the work, and have a draft of wind at two entrances.

2988. *The advantage of this mode of burning clay is the saving of cartage, as the clay may be always burned where it is dug.*

2989. *Burning clay and surface soil by lime without fuel, has been practised by Curwen, (Farm. Mag. vol. xvi. p. 11, 12.) in the following manner. Mounds of seven yards in length, three and a half in breadth, are kindled with seventy-two Winchester bushels of lime.*

First, a layer of dry sods or parings, on which a quantity of lime is spread, mixing sods with it, then a covering of eight inches of sods, on which the other half of the lime is spread, and covered a foot thick; the height of the mound being about a yard. In twenty-four hours it will take fire. The lime should be immediately from the kiln. It is better to suffer it to ignite itself, than to effect it by the operation of water. When the fire is fairly kindled, fresh sods must be applied. Mr. Curwen recommends obtaining a sufficient body of ashes before any clay was put on the mounds. The fire naturally rises to the top. It takes less time, and does more work to draw down the ashes from the top, and not to suffer it to rise above six feet. The former practice of burning in kilns was more expensive; did much less work; and, in many instances, calcined the ashes, and rendered them of no value.

2990. *Use of pyrites in burning clay.* A writer in *The Farmer's Journal* (Dec. 1821), asserts that "the greater part of many beds of cold clay contain in them a substance, or ingredient, which is in itself, to a great degree, combustible, as is known to every brick-burner. This probably is, in most cases, the sulphur of the pyrites contained in the clay; but be it what it may, it prevails to such a degree, that a very small quantity of fuel is usually sufficient to burn a very large body of clay. It is only requisite to have sufficient fuel to set fire to the heap at first, so as to raise a body of heat; and, for the rest, the clay will nearly burn of itself, being judiciously arranged round and upon the burning centre. The ashes are in the best state when they have been exposed only to a moderate heat; namely, to a heat not only far below what will produce vitrification, but even so low as not to produce a permanent red color: the black ashes, or dirty red, and brownish red, being made superior in value to bright red ashes, that is, to well burnt bricks. The heat is moderated chiefly by the judicious application of the crumbs and mouldering fragments of clay or soil, so as to prevent the draft of the air through the apertures between the large clods or tufts from being too free. A very small admixture of vegetable fuel suffices to keep up the fire.

2991. *The application of burnt clay as a manure is the same as that of lime: it is spread over fallows or lands in preparation for turnips, at the rate of from thirty to fifty loads or upwards per acre.*

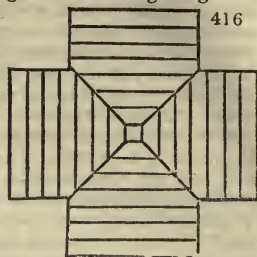

## CHAP. II.

### *Agricultural Operations requiring the Aid of Laboring Cattle.*

2992. *Operations requiring the aid of laboring cattle, are in a peculiar manner entitled to the appellation of agricultural. Almost all the operations described in the former Chapter, may be performed by common country laborers; but those we are now to enter on, are exclusively performed by farm servants. They may be classed as operations for the use and management of live stock, labors on the soil, and compound operation.*

#### SECT. I. *Operations for the Care of Live Stock.*

2993. *Herding or tending of cattle is the simplest operation with domestic animals. It consists in conducting them to a certain pasturage; keeping them within the prescribed limits; preventing them from injuring one another; observing if any are diseased, and the like. It is commonly performed with the aid of the dog, and by boys or girls for a small herd or flock, and aged or elderly men for larger herds. In modern times, the place of the cow and cattle herd is generally supplied by fences; but where large flocks of sheep are kept, it is still necessary to have a shepherd; not, in many cases, so much to keep the flock together and in its proper place, as to watch the progress of their*



growth, the approaches of disease, parturition, &c. In almost all cases, mild and gentle treatment ought to be made the *sine qua non* of the herdman's conduct.

2994. *Cleaning cattle* is the operation of rubbing, brushing, combing, and washing their bodies and picking their feet. The legs of cattle, when soiled by labor, are commonly washed by walking them two or three times through a pond, formed on purpose, in or near to farmeries. As soon as they are put in the stable and unharnessed, the legs, and such parts as are wetted, should be powerfully rubbed with dry straw, so as to dry the hair, and the same process should be applied to the rest of the body if they have been in a state of copious perspiration. At the same time their feet should be picked, and their hoofs freed from any earth or small stones which may have lodged under the shoe, or in the case of laboring oxen between the hoofs. Combing and brushing can only be performed when the hair and skin are perfectly dry, and in farmeries is generally done in the morning when they are first fed, and in the evening when last fed. In general, it may be considered as experimentally decided, that cleaning cattle of every description, cows and oxen, as well as horses, contributes much to their health as well as to their beauty. If swine were cleaned as regularly as horses, there can be no doubt they would be equally benefited by it. Some amateurs have their feeding swine regularly cleaned; but the greater part of professional agriculturists content themselves with fixing one or more rubbing posts in each sty, with frequent renewing of the litter.

2995. *Feeding or supplying food to cattle*, is an operation which, like every other, however simple or humble, requires attention and a principle of action. Food ought to be given at stated times, in such quantities as to satisfy but not glut the animals, and varied in quality so as to keep alive appetite. Water ought to be regularly supplied according to the kind of food, the state of the animal, and the season of the year. Cattle, who are fed in part on green food or roots, will require less water than those fed on dry hay, straw, or corn; and cattle that have been at work and perspiring, will require more water than such as have been idle or at pasture. In summer, cattle fed on dry food obviously require more water than in winter, owing to the increased perspiration. The case of sick animals must be regulated by the nature of their disease, or directed by the veterinary surgeon. In treating of agricultural animals, (Part III.) we shall give the diseases, and treatment of each.

2996. *The harnessing of cattle* requires attention, first, that the harness be in complete order; and secondly, that it fit the parts of the animal to which it is applied. Collars and saddles are the leading articles, and when they gall or in any way incommode the animal, they are ruinous to his comfort, and soon render him unfit for labor. Even when they fit properly, an improper mode of fixing the collar-blades (hames), and tying the girth of the saddle, may greatly annoy the animal, and render him restive during the whole period he is in yoke.

2997. *The yoking of draught animals* requires still more attention than harnessing them. To know when an animal is properly yoked, or placed in proper circumstances to perform the kind of labor assigned to him, it is necessary to have clear ideas as to the kind of power to be exerted by the animal, whether drawing, carrying, pushing, or two, or all of these. The horse and ox draw from their shoulders, carry from their back, and push with their breech. The point of resistance in all weights, or objects to be dragged or pushed along the ground's surface, lies below the centre of gravity; and in all cases of drawing, a line from this point of resistance to the collar of the animal, should form a right angle with the plane of the collar-bone. Hence the necessity of not suspending the plough chains from the back of the animal by means of the back band, as is sometimes done, but of allowing them to hang freely so as to form a straight line from the collar blades through the muzzle of the plough to the point of resistance. Hence also the advantage of yoking two horses in a cart by means of the endless rope or chain already described (2613.). In yoking animals where the labor is principally carrying a weight, as in carting, great care is requisite that the weight be not oppressive, and that the suspending chain move freely in the groove of the saddle so as to produce a perfect equipoise. Various opinions are entertained as to the weight which a horse can carry with or without drawing at the same time. According to the practice of experienced carters, if a one-horse cart is loaded with 20 cwt., 5 cwt., but not more, may be allowed to rest on the back of the horse by means of the traces, chain, and saddle. This is meant to apply where the roads are level; in going up or down hill to admit of the same proportion of weight, the traces, or shafts, or the bearing chain, must be lowered or raised according to circumstances. Yoking animals to push only, is a case that seldom or never occurs; but it will be useful to mention, that as the line of the breech of animals is nearly perpendicular to the horizon, so the principle being, that the line of exertion should be at right angles to the exerting surface; so the direction of pushing or backing, as it is commonly called, may be a horizontal line, or a line parallel to the surface on which the animal stands.

SECT. II. *Labors with Cattle on the Soil.*

2998. *Ploughing* is justly considered the most important of agricultural operations, as on the manner in which this is performed, depends the facility of executing all succeeding operations on the same piece of land. The plough acts as a wedge, separating a portion of the soil and turning it over at the same time. If this wedge is properly constructed, and if the soil presented everywhere the same resistance to it, it would require no holding, but would maintain its position when drawn along by the cattle; but as the least inequality of surface, or tenacity, or the additional resistance of a root or stone destroys the equilibrium of the forces acting against the wedge, the presence of the holder or ploughman becomes necessary to adjust its position. In two-wheeled ploughs, however, this is done in a great measure by the wheels, but not so rapidly as by the instantaneous movement of the holder on the ends of the handles acting as levers. The manual operation of holding the plough in a proper position, and directing the horses or cattle which draw it at the same time, is only to be acquired by experience; when once attained it is perhaps the most agreeable and healthy of agricultural exercises, the body being kept upright, the arms and legs brought into action, and also the eye and the mind, to keep the furrow straight and of regular width and depth, and the voice to speak to the horses. It is almost needless to mention that the art of drawing a straight furrow with a plough in which the horses are yoked in pairs, consists in keeping each of the horses a small distance apart, so as to see forward between them; and next to fix the eye on two or more objects beyond the land to be ploughed, and keep these objects and the coulter or muzzle of the plough always in one line. By far the best practical directions for ploughing have been given by the author of the article *Agriculture* in the supplement to the *Encyclopædia Brit.*, which we shall quote at length.

2999. *Three different points require particular attention in ploughing*: 1. The breadth of the slice to be cut; 2. its depth; and 3. the degree in which it is to be turned over; — which last circumstance depends both upon the construction of the plough, particularly the mould-board, and the care of the ploughman.

3000. *The breadth and depth of the furrow-slice* are regulated by judiciously placing the draught on the nozzle or bridle of the plough; setting it so as to go more or less deep, and to take more or less land or breadth of slice, according as may be desired. In general, the plough is so regulated that, if left to itself, and merely kept from falling over, it would cut a little broader and a little deeper than is required. The coulter is also placed with some inclination towards the left or land side, and the point of the sock or share has a slight tendency downwards.

3001. *The degree to which the furrow-slice turns over*, is in a great measure determined by the proportion between its breadth and depth, which for general purposes is usually as three is to two; or when the furrow is nine inches broad, it ought to be six inches in depth. When the slice is cut in this proportion, it will be nearly half turned over, or recline at an angle of forty or forty-five degrees; and a field so ploughed will have its ridges longitudinally ribbed into angular drills or ridgelets. But if the slice is much broader in proportion to its depth, it will be almost completely overturned, or left nearly flat with its original surface downwards; and each successive slice will be somewhat overlapped by that which was turned over immediately before it. And finally, when the depth materially exceeds the width, each furrow-slice will fall over on its side, leaving all the original surface bare, and only laid somewhat obliquely to the horizon.

3002. *Ploughing with the breadth and depth nearly in the proportion of three to two*, is best adapted for laying up stubble land after harvest, when it is to remain during winter exposed to the mellowing influence of frost, preparatory to fallow or turnips.

3003. *The shallow furrow of considerable width*, as five inches in depth by eight or nine wide, is understood to answer best for breaking up old leys; because it covers up the grass turf, and does not bury the manured soil.

3004. *Ploughing with the depth of the furrow considerably exceeding the width*, is a most unprofitable and uselessly slow operation, which ought seldom or never to be adopted.

3005. *The most generally useful breadth of a furrow-slice* is from eight to ten inches, and the depth, which ought to be seldom less than four inches, cannot often exceed six or eight inches, except in soils uncommonly thick and fertile. When it is necessary to go deeper, as for carrots and some other deep-rooted plants, a trench ploughing may be given by means of a second plough following in the same furrow.

3006. *Shallow ploughing* ought always to be adopted after turnips are eaten on the ground, that the manure may not be buried too deep; and also in covering lime, — especially if the ground has been pulverized by fallowing, because it naturally tends to sink in the soil. In ploughing down farm-yard dung, it is commonly necessary to go rather deep, that no part of the manure may be left exposed to the atmosphere. In the first ploughing for fallows or green crops, it is advisable to work as deep as possible, and no great danger is to be apprehended, though a small portion of the subsoil be at that time brought to the surface.

3007. *The furrow-slices are generally distributed into beds* varying in breadth according to circumstances; these are called *ridges or lands*, and are divided from one another by gutters or open furrows. These last serve as guides to the hand and eye of the sower to the reapers, and also for the application of manures in a regular manner. In soils of a strong or retentive nature, or which have wet close subsoils, these furrows serve likewise as drains for carrying off the surface water, and being cleared out, after the land is sown and harrowed, have the name of *water furrows*.

3008. *Ridges* are not only different in breadth, but are raised more or less in the middle, on different soils. On clayey retentive soils, the great point to be attended to is the discharge of superfluous water. But narrow ridges or *stitches* of from three to five feet, are not approved of in some of the best cultivated counties. In these a breadth of fifteen or eighteen feet, the land raised by two gatherings of the plough, is most commonly adopted for such soils; such ridges being thought more convenient for manuring, sowing, harrowing, and reaping, than narrower ones; and the water is drained off quite as effectually.

3009. *Ridges on dry porous turnip soils*, may be formed much broader; and were it not for their use in directing the laborers, may be, and sometimes are, dispensed with altogether. They are often thirty, or thirty-six feet broad, which in Scotland are called *band-win* ridges, because reaped by a band of shearers, commonly six, served by one binder. If it be wished to obliterate the intermediate furrows, this may be done by casting up a narrow ridgelet or single bout-drill between the broad ridges, which is afterwards levelled by the harrows.

3010. *The mode of forming ridges, straight and of uniform breadth*, is as follows; let us suppose a field perfectly level that is intended to be laid off into ridges of any determinable breadth. The best ploughman belonging to the farm conducts the operation, with the aid of three or more poles shod with iron, in

the following manner: The first thing is to mark off the head ridges, on which the horses turn in ploughing, which should in general be of an equal breadth from the bounding lines of the field, if these lines are not very crooked or irregular. The next operation, assuming one straight side of the field, or a line that has been made straight, as the proper direction of the ridges, is to measure off from it with one of the poles (all of them of a certain length, or expressing specific measures), half the intended breadth of the ridge, if it is to be gathered, or one breadth and a half if to be ploughed flat; and there the ploughman sets up a pole as a direction for the plough to enter. On a line with this, and at some distance, he plants a second pole, and then in the same manner a third, fourth, &c., as the irregularity of the surface may render necessary, though three must always be employed, — the last of them at the end of the intended ridge, and the whole in one straight line. He then enters the plough at the first pole, keeping the line of poles exactly between his horses, and ploughs down all the poles successively; halting his horses at each, and replacing it at so many feet distant as the ridges are to be broad; so that when he reaches the end of the ridge, all his poles are again set up in a new line parallel to the first. He returns however, along his former track, correcting any deviations, and throwing a shallow furrow on the side opposite to his former one. These furrows, when reversed, form the crown of the ridge, and direct the ploughmen who are to follow. The same operations are carried on until the whole field is marked out. This is called *feiring* in Scotland, and *striking the furrows* in England. It is surprising with what accuracy these lines are drawn by skilful ploughmen.

3011. *Another method* has been adopted for the same purpose, which promises to be useful with less experienced workmen. A stout lath or pole, exactly equal in length to the breadth of the intended ridge, is fixed to the plough, at right angles to the line of the draught, one end of which is placed across the handles exactly opposite the coulter, while the other end projects towards the left hand of the ploughman, and is preserved in its place by a rope passing from it to the collar of the near side horse. At the outer end of the lath, a coulter or harrow tine is fixed perpendicularly, which makes a trace or mark on the ground as the plough moves onwards, exactly parallel to the line of draught. By this device, when the plough is *feiring* the crown of one ridge, the marker traces the line on which the next ridge is to be *feired*. (*General Report of Scotland*, vol. i. p. 354.)

3012. *The direction and length of ridges*, are points which must evidently be regulated by the nature of the surface, and the size of the field. Short angular ridges, called *buts*, which are often necessary in a field with irregular boundaries, are always attended with a considerable loss of time, and ought to be avoided as much as possible.

3013. *In ploughing steep land* it is advisable to give the ridges an inclination towards the right hand at the top, by which, in going up the acclivity, the furrow falls more readily from the plough, and with less fatigue to the horses. Another advantage of forming ridges in a slanting direction on such land is, that the soil is not so apt to be washed down from the higher ground, as if the ridges were laid at right angles. Wherever circumstances will permit, the best direction, however, is due north and south, by which the grain on both sides of the ridge enjoys nearly equal advantages from the influence of the sun.

3014. *Ribbing*, a kind of imperfect ploughing, was formerly common on land intended for barley, and was executed soon after harvest, as a preparation for the spring ploughings. A similar operation is still in use in some places, after land has been pulverized by clean ploughings, and is ready for receiving the seed. By this method only half the land is stirred, the furrow being laid over quite flat, and covering an equal space of the level surface. But, except in the latter instance, where corn is meant to grow in parallel lines, and where it is used as a substitute for a drill-machine, ribbing is highly objectionable, and has become almost obsolete.

3015. *Land thus formed into ridges*, is afterwards cultivated without marking out the ridges anew, until the inter-furrows have been obliterated by a fallow or fallow crop. This is done by one or other of the following modes of ploughing. 1. If the soil be dry, and the land has been ploughed flat, the ridges are split out in such a way, that the space which the crown of the old ridge occupied is now allotted to the open furrow between the new ones. This is technically called *crown and furrow ploughing*. 2. When the soil is naturally rather wet, or, if the ridges have been raised a little by former ploughings, the form of the old ridges, and the situation of the inter-furrows, are preserved by what is called *casting*, that is, the furrows of each ridge are all laid in one direction, while those of the next adjoining ridges are turned the contrary way; two ridges being always ploughed together. 3. It is commonly necessary to raise the ridges on soils very tenacious of moisture, by what is called *gathering*, which is done by the plough going round the ridge, beginning at the crown and raising all the furrow slices inwards. 4. This last operation, when it is wished to give the land a level surface, as in fallowing, is reversed by turning all the furrow-slices outwards; beginning at the inter-furrows, and leaving an open furrow on the crown of each ridge. In order to bring the land into as level a state as possible, the same mode of ploughing or cleaning, as it is called, may be repeated as often as necessary.

3016. *With respect to ploughing relatively to time*, in the strongest lands, a pair of good horses ought to plough three quarters of an acre in nine hours, but upon the same land, after the first ploughing, on friable soils, one acre, or an acre and a quarter is a common day's work. Throughout the year, an acre a day may be considered as a full average, on soils of a medium consistency. The whole series of furrows on an English statute acre, supposing each to be nine inches broad, would extend to 19,360 yards; and adding twelve yards to every 220 for the ground travelled over in turning, the whole work of one acre may be estimated as extending to 20,416 yards, or eleven miles and nearly five furlongs.

3017. *In ploughing relatively to season*, it is well known, that clayey or tenacious soils should never be ploughed when wet; and that it is almost equally improper to allow them to become too dry; especially if a crop is to be sown without a second ploughing. The state in which such lands should be ploughed is that which is commonly indicated by the phrase, "between the wet and the dry," — while the ground is slightly moist, mellow, and the least cohesive.

3018. *The season best for ploughing the first time for fallow or green crops*, is immediately after harvest, or after wheat sowing is finished; and when this land has been gone

over, the old tough swards, if there be any, are next turned up. The reasons for ploughing so early are sufficiently obvious; as the frosts of winter render the soil more friable for the spring operations, and assist in destroying the weed roots. In some places, however, the first ploughing for fallow is still delayed till after the spring seed-time.

3019. *The cultivator, grubber, scuffler, scarifiers* and such like implements (2533.), are used to lessen the number of ploughings in fallows or light free soils. Their operation differs from that of the plough in not reversing the surface, and therefore they can never, as some have proposed, become a substitute for that implement. Still the grubber is a valuable implement. William Lester, late of Northampton, who is said first to have invented an implement of this kind, declares himself confident that one man, a boy, and six horses, will move as much land in a day, and as effectually, as six ploughs:—meaning land in a fallow state, that has been previously ploughed. We have elsewhere pointed out the mode of using this description of tillage implements (227.), one great advantage of which is that they may be used by the unskilful, and even by operators who cannot guide a plough.

3020. *The operation of harrowing* is intended both to drag out weeds and to cover the seeds when sown. It is obvious that implements of different sizes are not only necessary, but even that these implements should be worked in different ways, according to the strength and condition of the soil on which they are employed, and the nature of the work to be executed. When employed to reduce a strong obdurate soil, not more than two of the common sort (2569.) should be yoked together, because they are apt to ride and tumble upon each other, and thus impede the work, and execute it imperfectly. It may also be remarked that on rough soils, harrows ought to be driven as fast as the horses can walk; because their effect is in direct proportion to the degree of velocity with which they are driven. In ordinary cases, and in every case where harrowing is meant for covering the seed, and the common implement in use, three harrows are the best yoke, because they fill up the ground more effectually, and leave fewer vacancies, than when a smaller number is employed: the improved forms, calculated to cover the breadth of two or more of the old harrows by one frame (fig. 417.), are only calculated for flat ridges; or for working dry lands in which ridging is not requisite.

3021. *The harrow-man's attention, at the seed process,* should be constantly directed to prevent these implements from riding upon each other, and to keep them clear of every impediment, from stones, lumps of earth, or clods, and quickens or grass roots; for any of these prevent the implement from working with perfection, and causes a mark or trail upon the surface, always displeasing to the eye, and generally detrimental to the vegetation of the seed.

3022. *Harrowing is usually given in different directions,* first in length, then across, and finally in length, as at first. Careful agricultors study, in the finishing part of the process, to have the harrows drawn in a straight line, without suffering the horses to go in a zig-zag manner, and are also attentive that the horses enter fairly upon the ridge, without making a curve at the out-set. In some instances, an excess of harrowing has been found very prejudicial to the succeeding crop; but it is always necessary to give so much as to break the furrow, and level the surface, otherwise the operation is imperfectly performed.

3023. *Horse hoeing* is the operation of stirring the ground between rows of vegetables, by means of implements of the hoe, coulter, or pronged kind, drawn by horses. Whoever can guide a plough will find no difficulty in managing any implement used for stirring ground. The easiest kinds are those which have few hoes or coulters, or shares, and a wheel in front; and the easiest circumstances, wide intervals between the rows, and a loose friable soil. Wherever soil is hard, rough, rounded, as in the case of high-raised ridges, there should not be more than three prongs or shares in the implement, because more than three points can never touch a curved surface, and be in one plane; and if not in one plane, they will never work steadily, equally, and agreeably.

3024. *Turnip hoeing* of every kind is accordingly exceedingly easy; but stirring the

417

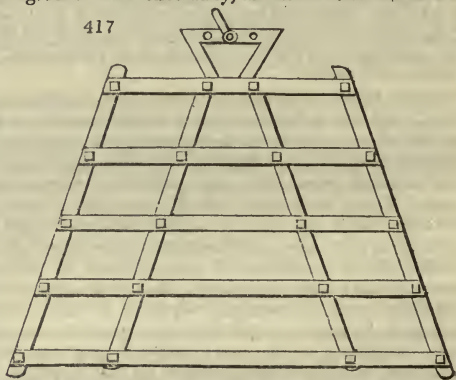

earth between rows of beans on a strong clay soil in a time of drought is proportionally difficult, and sometimes, when the ground rises in large lumps, dangerous for the plants. In stirring the soil between rows of beans, cabbages, or other plants, on strong or loamy soils, a small plough often answers better than any of the pronged or coulted implements, at least for the first and last operation of bean culture. Dr. Anderson, indeed, affirms with great truth, that nearly all the various operations of horse-hoeing may be executed by the common swing-plough in an equally effectual manner, as by any of the hoe-ploughs usually made use of.

3025. *Drilling*, or the deposition of seed in rows by means of a drill machine, is an operation that requires considerable care in the performance. The points that require particular attention are keeping the rows straight and at equal distances throughout their length, depositing the seed at a proper depth, and delivering the seed in proper quantity according to its kind and the nature of the soil. For these purposes the ground must have been previously well prepared by ploughings and harrowings, excepting in the particular case of drilling beans with one furrow. This operation is generally performed in the course of ploughing, either by a person pushing forward a bean-drill barrow, or by attaching a hopper and wheel, with the necessary apparatus to the plough itself. The mode of regulating the depth of the drill, and the quantity of seed delivered, must depend on the kind of drill used, and only requires attention in the holder. In drilling turnips the land is most generally made up into ridgelets 27 or 30 inches centre from centre, by a single *bout* (go about), or return of the common plough. The Northumberland machine which sows two rows at once, is then drawn over them by one horse walking between the ridges without a driver, the holder at once performing that operation and keeping the machine steady on the tops of the drills. One of the two rollers of this machine smooths the tops of the ridges before the seed is deposited, and the other follows and compresses the soil and covers the seed.

3026. *In drilling corn* several rows are sown at once, and great care is requisite to keep the machine steady and in a straight line: for most soils two horses and a driver are required for this purpose; the driver aiding in filling the hopper with seed, &c.

3027. *In all cases of drilling* it must be recollected that the principal intention of the operation is to admit of horse-hoeing the crop afterwards; hence the necessity of straight rows and uniform distances; and hence also the advantage of burying the manure under the drill or row, that it may not be exposed to the air in after-working.

3028. *Rolling* is the operation of drawing a roller over the surface of the ground with the view of breaking down the clods, rendering it more compact, and bringing it even and level; or it may be limited to smoothing and consolidating the surface. It is practised both upon the tillage and grass lands, and is of much utility in both sorts of husbandry. In the former case it is made use of for the purpose of breaking down and reducing the cloddy and lumpy parts of the soil in preparing it for the reception of crops, and in rendering light soils more firm, even, and solid, after the seed is put in. It is likewise found beneficial to the young crops in the early spring in various instances. In order to perform this operation in the most complete and effectual manner a roller of considerable weight is necessary; and in order to prevent, as much as possible, the ground from being injured by the feet of the animals that draw it, as may frequently be the case where they follow each other in the same tract, it is the best practice to have them yoked double, as by that means there will be less treading on the same portion of surface. Where two horses are sufficient to execute the work more should never be made use of; but if a third should be found necessary, it may be attached as a leader in the middle before the other two: a greater number of horses can seldom or ever be of any material advantage in this sort of work. It is necessary to see that every part of the surface receives the due impression of the implement, and that the head lands are not injured by the turnings. On lands where the work is regularly performed, it will seldom be requisite to pass more than once in a place, but in other cases it may often be done more frequently with benefit, and in particular cases a more frequent repetition of the operation is absolutely requisite in order to bring the ground into a proper state.

3029. *In rolling grass lands* it is necessary to attend in a particular manner to the season, as it cannot be performed with advantage either when the surface is in too dry or too moist a condition. In these cases the work of rolling may be advantageously performed at different seasons, as in the beginning of the autumn, and in the commencement of the year, or very early spring months: but the latter is the most common period. In the drier descriptions of land it may frequently be performed in the most beneficial manner, after the land has been rendered a little soft by a moderate fall of rain; but in those of the contrary sort, it may be necessary to wait till the superabundant moisture be so much dried up, as to admit the animals employed in drawing the machine without poaching, or otherwise injuring the surface of the ground while the process is going on. The rolling of watered meadows, it has been remarked by Boswell, should be executed towards the latter end of February or beginning of the following month,

after the land has been left in a dry state for a week or ten days. The work should be performed lengthwise of the panes, going up one side of the trenches and down the other. And in the case of rolling the common hay lands, it is a good mode to proceed up one side of the field and down the other, somewhat in a similar manner, as by that means the work may be the most completely executed.

3030. *Horse-raking*, or the collecting the scattered straws of corn or hay crops by the rake, is an operation of little art or trouble in the execution. The proper implement being employed, it is generally drawn by one horse, conducted by a man, who walks behind, and when the rake fills, lifts it up without stopping the horse, and always at the same place, so as to deposit the rakings in regular rows across the field. The same mode is followed whether in raking hay, corn, stubble, or weeds from fallow grounds.

3031. *Driving carts and waggons*, though the easiest of all operations, is very frequently shamefully performed by servants. Almost every body knows this; and it is humiliating to consider that we are considered the most inhuman nation in Europe in our treatment of horses. In most other countries these animals, and even oxen, are taught to obey the word of the driver; but in Britain he requires both halter or rein, and a whip; and in most parts of England the slightest movement from right to left is indicated to the animal by the latter implement. Driving is more especially neglected, or wretchedly performed, near large towns, and especially round London, where little or no attention is paid to avoiding the ruts; choosing the best part of the road; going in a direct line; altering the position of the load (by means of the back chain or the construction of the cart where that admits of it) in going up or down hill; or seeing whether both horses (where two are used), draw equally. The reverse of this conduct ought to be that of a careful and humane driver, who being first certain that his cattle are properly yoked and his load fairly adjusted so as to be neither too heavy nor too light for the wheel or shaft horse, will see that they proceed along the best part of the road in a straight line, avoiding the ruts when deep or unequal — that all the horses draw equally as far as practicable — that proper care and timely precautions be taken to avoid other machines meeting or passing, and that no sudden motion or jerk of the horses, be required on any occasion. In dividing the road where it is steep or in a bad state, the horses ought to be drawn aside gradually, and gradually led on again; it being easier to descend or ascend either a good or bad convex road obliquely, than at an acute angle. Lastly, servants ought on no account to be allowed to ride on laden carts or waggons, especially the former; or to walk at a distance from them either before or behind. There are many other points which require attending to in this department of agriculture, such as not striking animals on the head or legs; nor kicking them, or using a pole or handle of any implement that may be at hand, in administering chastisement; but these must be left to the care and discretion of masters, whose interest it is to be most vigilant in watching those who are engaged in this department.

3032. *One mode of lessening the evils of careless driving* and inhumanity to animals, consists in employing chiefly married servants, and as is generally the case, letting each have the exclusive care and working of one pair of horses. Such men are steadier, and remain much longer in their situations than single men, and are therefore more likely to feel an interest in the welfare and good condition of their horses, as well as in the good opinion of their employer.

3033. *Driving cattle in a threshing machine* required particular care before the ingenious invention described (2638.) to equalize the draught of the different animals; where this invention is applied it requires, little more than speaking to such of the cattle as have a tendency to relax in their exertions.

### SECT. III. *Labors and Operations with the Crop.*

3034. *Labors with the crop*, chiefly comprise stacking and housing.

3035. *Stacking* is the operation of building or piling up unthreshed corn, hay, straw, or other dried crops in convenient forms, and so as to admit of their being thatched as a defence from the weather. Stacks are of various forms and dimensions, according to circumstances; in some districts they are formed square or oblong, both for hay and corn; but where threshing machines are in use, the circular base with cylindrical body, diverging a little at the eaves, and a conical top, is decidedly preferred, as being more convenient in size and form, and better adapted for early stacking in wet seasons than any other. For hay the form of the stack is a matter of less consequence; the long square or oblong shapes, are perhaps the most safe and convenient, especially when not too broad, as they are the most suitable to cut from in trussing hay for sale.

3036. In respect to *the sizes of corn-stacks of the square sort*, they of course vary greatly according to circumstances; but they should never be made too large, as there is a great deal more risk in securing and getting in the grain from them; and from their being built at different times, they do not settle altogether in so perfect a manner, or resist the effects of the weather and keep the grain so well as those of less dimensions that can be completed at once: and in addition, they are less convenient in the threshing out, especially

where the flail is employed. The chief advantages they possess are those of taking something less in thatch and labor in covering them.

3037. *The proper size of the hay-stack* should probably be different in some degree according to the state and nature of the hay; but a middling size is perhaps the best, as from twenty to thirty loads of about one ton each, as there are inconveniences in both small and large stacks, the former having too much outside, while the latter are liable to take on too much heat, and at the same time permit less moisture to be preserved in the hay. In small stacks the bellying forms with very narrow bottoms have often much advantage, and are in some districts termed sheep-stacks, probably from the slovenly practice of sheep having been permitted to feed at them.

3038. *In building every description of stack*, the stem or body should be so formed as to swell gradually outwards, quite up to the part termed the eaves, as by this method it is more perfectly secured against the entrance of moisture, and at the same time requires a less space of stand to rest upon. And when the building of them is well performed, they have equal solidity, and stand in as firm a manner.

3039. *The stem* should contain about two-thirds, and the roof one-third of the whole stack. If it be built on a frame, the stem should contain less and the roof more; if on a bottom the reverse. The corners of the stem should not be built too sharp; should be carried up snug; by which the sides will look fuller, and the swell given by the pressure will be more perceptible.

3040. *The ends of the roof* should have a gentle projection, answerable to the stem; and the sides should be carried up rather convex, than flat or concave. Perhaps a roof gently convex shoots off the rains preferably to any other.

3041. *Where corn is stacked that has not been sheaved*, and in building hay-stacks it is the usual practice to have a number of persons upon the stack, the corn or hay being forked up and deposited on the different sides all round in a similar method; after this other parcels are laid all round on the inside of these, so as to bind them in a secure manner from slipping outwards; the operator proceeding in the same manner till the whole of the middle space is perfectly filled up: when he begins another course in the same method, and goes on in this mode, with course after course, till he has raised the whole of the stem; when he begins to take in for the roof, in a very gradual manner, in every succeeding course until the whole is brought to a ridge or point, according to the manner the stack is formed in. But for the purpose that the roofs may throw off the water in a more perfect and effectual manner, they should be made so as to have a slight degree of fullness or swell about the middle of them, and not be made flat, as is too frequently the practice with indifferent builders of stacks.

3042. *In stacking, where the corn is bound into sheaves*, there is seldom more than one person employed in managing the work of building the stack, except in cases where the dimensions are very considerable; in which cases it is found necessary to have a boy to receive the sheaves from the pitcher, and hand them to the man who builds the stack. In executing the work it is of the utmost importance that the centre of the stack be constantly kept in a somewhat raised state above that of the sides, as by this means the sheaves have a sloping direction outwards, by which the entrance of moisture is more effectually guarded against and prevented. To accomplish this in the most perfect method, the workman begins in the middle of the stand or saddle, setting the sheaves together so as that they may incline a little against each other, placing the rest in successive rows against them till he comes to the outside, when he carries a course of sheaves quite round, in a more sloping manner than in the preceding courses. The bottom of the stack, being formed in this way, it is afterwards usual to begin at the outside, and advance with different courses round the whole, placing each course a little within the other, so as to bind them in an exact and careful manner, till the stacker comes to the middle. And all the different courses are to be laid on in a similar manner until the whole of the stem is raised and completed; when the last outside row of sheaves is, in most cases, placed a very little more out than the others, in order to form a sort of projection for the eaves, that the water may be thrown off more effectually. But in cases where the stems of the stacks are formed so as to project outwards in the manner already noticed, this may be omitted without any bad consequences, as the water will be thrown off easily without touching the waste of the stack. And the roof is to be formed by placing the sheaves gradually a little more in and in, in every course, until it comes to a ridge or point, according to the form of the stack, as has been already observed. But in forming and constructing this part of the stack, great care should constantly be taken to give the ear-ends of the sheaves a sufficiently sloping direction upwards, in order that they may be the better secured from wetness. And to the outside should be given a rounded form, in the manner that has been already noticed.

3043. *A funnel or chimney* is frequently formed or left in circular stacks, especially in wet districts, in order to prevent their taking on too much heat; where these funnels are not formed with the basement of timber, iron, or masonry, as already shown (2746.), they are produced by tying a sheaf up in a very tight manner, and placing it in the middle on the foundation of the stack, pulling it up occasionally as the building of the stack proceeds all round it. In setting up ricks in bad harvests, it is a practice in some places,

particularly with barley crops, to have three or four pretty large poles tied together, by winding straw ropes round them, set up in the middle, round which the stacks are then built. But except the stacks are large, or the grain when put into them in an imperfect condition, such openings are quite unnecessary.

3044. *The stacking of hay* requires much care and attention in the person employed for the purpose, though less than that of building corn stacks. There should constantly be a proper stand or foundation, somewhat raised by wood or other materials, prepared for placing the stacks upon; but nothing of the coping kind is here necessary. In the business of stacking hay, the work should constantly be performed as much as possible while the sun is upon the hay, as much advantage is thus gained in its quality: and it is necessary to have a stacker that has been accustomed to the business, and a proper number of persons to help upon the stack, in order that it may be well spread out and trodden down.

3045. *The building of hay-stacks* should be conducted much in the same way as those of loose grain (3041.); the middle of the stack being always well kept up a little higher than the sides, and the sides and ends well bound in by the proper application of the successive portions of hay as the work advances, and during which it is a good way, where there are plenty of hands, to have the sides and ends properly pulled into form, as by this means much after-labor is prevented. It is likewise of advantage, that the hay should be well shaken and broken from the lumps, during the operation of stacking. The form in which the stacks are built is not of much consequence, but if large, and made in the square form, it is better not to have them too broad, or of too great width, as by this means they are less apt to heat. With the intention of preventing too much heat, sometimes in building hay-stacks, as well as those of the grain kind, holes, pipes, and chimneys are left in the middle, that the excessive heat may be discharged. But there is often injury sustained by them, from their attracting too much moisture.

3046. *The hay-stacks of Middlesex*, it is observed by Middleton, are more neatly formed and better secured than any where else. At every vacant time, while the stack is carrying up, the men are employed in pulling it with their hands into a proper shape, and about a week after it is finished the whole roof is properly thatched, and then secured from receiving any damage from the wind, by means of a straw rope, extending along the eaves, up the ends, and near the ridge. The ends of the thatch are afterwards cut evenly below the eaves of the stack, just of sufficient length for the rain water to drip quite clear off the hay. When the stack happens to be placed in a situation which may be suspected of being too damp in the winter, a trench of about six or eight inches deep is dug round, and nearly close to it, which serves to convey all the water from the spot, and renders it perfectly dry and secure.

3047. *The stack guard* (fig. 418.), or covering of canvass, is employed in some districts to protect the stack while building in a wet season. In Kent and Surrey, the half worn sails of ships are made use of for this purpose, though in most parts of the north, a covering of loose straw or hay is found sufficient in ordinary cases; but where, from a continued rain, the stack is penetrated some way down, a part is removed on recommencing, and dried before being replaced. It is observed by Marshal, that a sail cloth thrown over, and immediately upon the hay of a stack in full heat, is liable to do more injury by increasing the heat, and at the same time checking the ascent of the steam, than service in shooting off rain water. The improved method of spreading the cloth, he describes as follows: two tall poles (*a, a*) are inserted firmly in two cart wheels (*b, b*), which are laid flat upon the ground at each end of the stack, and loaded with stones to increase their stability. Another pole of the same kind, and somewhat longer than the stack, is furnished at each end with an iron ring or hoop, large enough to admit the upright poles and to pass freely upon them. Near the head of each of the standards is a

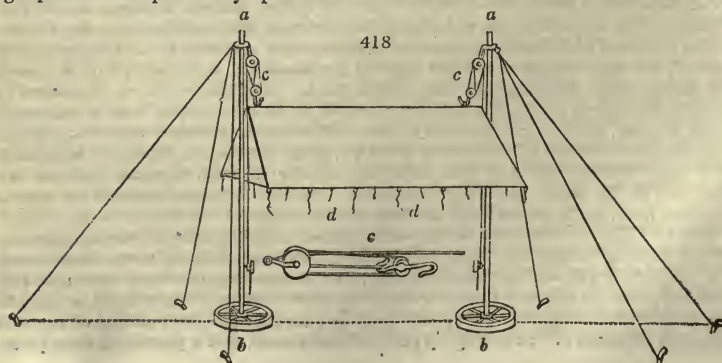



pulley (*c, c*), over which a rope is passed from the ring or end of the horizontal pole, by which it is easily raised or lowered, to suit the given height of the stack. A cloth being now thrown over the horizontal pole, and its lower margins loaded with weights, a complete roof is formed and neatly fitted to the stack, whether it be high or low, wide or narrow; the eaves being always adjusted to the wall plate, or upper part of the stem of the stack; thus effectually shooting off rain water, while the internal moisture or steam escapes freely at either end as the wind may happen to blow. This contrivance is readily put up or taken away; the poles being light are easily moved from stack to stack, or laid up for another season, and the wheels are readily removed or returned to their axles. On the whole, it answers as a good substitute for the improved construction brought into use by Sir Joseph Banks, and is much less expensive. This construction, instead of the ring running on the poles, has blocks and tackle (*c, c*), and instead of weights to distend the cloth, ropes (*d, d*) are used to tighten it and keep it detached from the sides of the stack, so as to admit a more free circulation of air.

3048. *A stacking stage* (*fig. 419.*), or scaffold, has been contrived for finishing the upper parts of high stacks, but it can seldom be requisite when a judicious size of stack is adopted. This stage, which consists of a frame (*a*) and a moveable platform (*b*), easily understood and constructed, is set against the stack when it becomes so high, that it is inconvenient to pitch on to it from the cross plank of a waggon. The platform is commonly fixed by means of the chain pins and holes, about fourteen feet from the ground, which is about the height of a waggon load of hay. Should it be fixed lower, it would be of no use; and should it be fixed much higher, it would be found too high for a man to pitch on to, when the waggon is nearly empty.

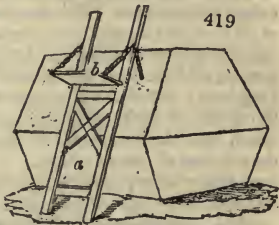

3049. The term *housing* is chiefly applied to crops of the root kind, as potatoes, carrots, turnips, &c. Potatoes being gathered in dry weather are preserved by being laid up in heaps, excluded from rain and frost more particularly, and from the weather generally, whether dry, moist, cold, or hot. The mode of doing this in some places is to form them into heaps on the surface of the soil, and cover them with a thick layer of straw, and on that another of earth. Sometimes also, where the soil is dry, they are buried in pits and similarly covered; but for common agricultural purposes, by much the best mode is to lay them up in a house, securing them from all extremes of weather by a covering of straw. By this mode they are much easier got at when a portion is wanted, than by any other in use.

3050. *In housing carrots and Swedish or yellow turnips*, the same modes may be adopted as for potatoes; but in housing white turnips, as they are apt to rot when heaped up, the best mode is to spread them thinly on any surface covered from the rain, but freely exposed to the circulation of air. This mode, it must be evident, can only be adopted to a limited extent, and, indeed, is only resorted to as a precautionary measure during winter, when frosts, snows, or continued rains, might interrupt the lifting and carting from the fields of the usual supplies for feeding stock.

3051. *Various modes of housing and preserving* these and other roots, will be treated of as each particular crop comes into notice in a succeeding Book (VI.)

### CHAP. III.

#### *Scientific Operations, and Operations of Order and general Management.*

3052. *All the operations which have hitherto been described* require to be practically known to every farm servant or operative agriculturist; the few about to be described belong more particularly to the superintendent or master: they may be arranged as scientific operations, and operations of order and management.

#### SECT. I. *Scientific Operations required of the Agriculturist.*

3053. *The scientific operations required of the agriculturist* are chiefly the measuring surfaces, measuring solids, taking the levels of surfaces, dividing lands; and valuing lands, timber, leases, and farming stock. A knowledge of the more common practices of surveying, measuring, and the calculation of annuities may be considered as essential to every agriculturist, whether farmer, land agent, or proprietor, who is desirous of having clear ideas on the subject of letting labor, hiring or letting farms, or purchasing estates. Such knowledge is not to be expected in detail in this work, but must be procured from the ordinary school, and annuity books, and is indeed implied in a regular education. All we propose here is to direct the reader's attention to the most important points of the art of surveying, and lay down the leading principles of valuing agricultural property.

SUBJECT. 1. *Of Measuring relatively to Agriculture.*

3054. *The measuring of land*, or other objects, comprises three distinct operations; viz. taking the dimensions of any tract or piece of ground; delineating or laying down the same in a map or draught, and calculating the area or superficial contents. The dimensions on a small scale are best taken by rods of wood, but in all ordinary and extensive cases by a chain of iron, as being less likely to contract or expand by changes of temperature, than cord lines or tapes. In measuring a simple figure, such as a square field, nothing more is necessary than to take the length and breadth, which multiplied together give the superficial area; but as few fields are square, or even right angled, it becomes necessary to adopt some guiding line or form within the field, and from that line or form to measure to the different angles, so as to be able from the dimensions taken, either to calculate the contents at once, or to lay down the form of the field on paper, according to a certain scale, or proportion to its real size, and from that to take dimensions and calculate the contents. The simplest and most accurate mode of ascertaining the contents of all irregular figures is by throwing them into triangles; and this also is the most accurate mode of measuring and protracting a whole landed estate, however large. In short, a triangle is the form universally adopted, whether in surveying a single field, or a whole kingdom. To find the contents of a triangle every body knows that it is only necessary to multiply half the perpendicular into the base. These two principles properly understood, form the foundation of measuring, protracting, and estimating the contents of territorial, and all other surfaces. In surveying hilly lands, an allowance is made both in protracting them, and calculating their contents, well known to surveyors, and not necessary to be entered into here.

3055. *In measuring solid bodies*, the rule is to "find the area of one end, and multiply that by the length." This rule is of universal application, whether to land as in excavating or removing protuberances; to ricks of corn; heaps of dung; timber; or water. The area of one end, or of one surface, whether the end, side, top, or bottom, is found exactly on the same principles as in ascertaining the superficial contents of land, and if the figure diminishes in dimension in the course of its length, as the top of a rick, or the trunk of a tree, the mean length or half is taken as a multiplier.

3056. *Measuring objects by the eye*, though a mode that can never be depended on as the foundation for any important calculation or transaction, yet should be constantly practised by young men for the sake of gaining habits of attention, and acquiring ideas as to number and quantity at first sight. The principle on which this sort of eye measurement is acquired, is that of ascertaining the actual dimension of some near object, and applying it as a measure to all the others seen beyond it. Thus, if a man is seen standing by a post or a tree at a distance, taking the height of the man at five and a half, or six feet; apply the figure of the man to the tree, and find how many applications will reach its top; that number multiplied by the ordinary height of a man, will of course be a near approximation to its height. Again, supposing this tree one in a row or avenue, then to estimate the length of the avenue, measure the third or fourth tree by the man, and measure by the same means the distance of that tree from the first, then state the question thus: as the difference between the height of the first and fourth tree is to the horizontal distance between them, so is the difference between the first and last tree of the avenue, to the length of the avenue. In this way, the length and breadth of a field may be estimated by observing the height of the hedge, at the nearest side, and the apparent height at the farthest points. The breadth of ridges and their number, teams at work, or cattle grazing, or accidental passengers, are all objects of known dimensions, which may be made use of in this way of estimating the contents of lands. In regard to houses, the doors, and windows, and size of bricks, stones, boards, tiles, &c. are obvious and certain guides.

3057. *The recollection of surfaces and of country* is a matter of considerable interest to every one, but especially to the agriculturist. The most effectual mode of impressing scenery on the memory is by the study and practice of sketching landscape. In addition to this it will be useful to pay attention to the natural surface and productions, as, kind of tree or crop, hills, valleys, flats, lakes, rills, &c.; also, the distant scenery, as whether flat, hilly, cultivated, waste, woody or watery; what processes are going on; what the style of houses, dress, &c. Having attended to these details, the next and the most important aid to the memory is, to recollect what portion of country already known to us it most resembles.

3058. *In endeavoring to recollect the surface and objects composing an entire estate* some leading central object, as the house, should be fixed on, and the bearings of other objects relative to it, ascertained in idea. Then either by going over the estate, or by a favorable position on the house-top, or some other eminence, the outline of the fields, or other scenery nearest the house, may be taken down, or remembered, and also the distant scenery, or that exterior to the estate. In riding through a country which it is desired to

recollect, a sketch should be made in imagination of the road and the leading objects adjoining; another of what may be called the objects in the middle distance; and finally, one of the farthest distance. If instead of the imagination, a memorandum book were used, and the sketches accompanied with notes, the country examined would be firmly impressed on the memory. In this way temporary military maps are formed by the engineers of the army in a few hours, and with astonishing accuracy.

SUBSECT. 2. *Of taking the Levels of Surfaces.*

3059. *Levelling*, or the operation of taking the levels of surfaces, is of essential use in agriculture for ascertaining the practicability of bringing water to particular points in order to drive machinery; for irrigation; for roads led along the sides of hills; for drainages, and various other purposes. There are few works on the earth's surface more useful, grand, and agreeable than that of a road ascending, passing over, and descending a range of steep irregular mountains, but every where of the same and of a convenient slope; next to this is a canal passing through an irregular country, every where on the same level.

3060. *Two or more places are said to be on a true level* when they are equally distant from the centre of the earth. Also, one place is higher than another, or out of level with it, when it is farther from the centre of the earth: and a line equally distant from that centre in all its points, is called the line of true level. Hence because the earth is round, that line must be a curve, and make a part of the earth's circumference, or at least parallel to it, or concentric with it.

3061. *The line of sight given by the operation of levelling*, is a tangent, or a right line perpendicular to the semidiameter of the earth at the point of contact, rising always higher above the true line of level, the farther the distance is, which is called the *apparent line of level*, the difference of which is always equal to the excess of the secant of the arch of distance above the radius of the earth.

3062. *The common methods of levelling* are sufficient for conveying water to small distances, &c. but in more extensive operations, as in levelling for canals, which are to convey water to the distance of many miles, and such like, the difference between the true and the apparent level must be taken into the account, which is equal to the square of the distance between the places, divided by the diameter of the earth, and consequently it is always proportional to the square of the distance; or from calculation almost eight inches, for the height of the *apparent* above the *true* level at the distance of one mile. Thus, by proportioning the excesses in altitude according to the squares of the distances, tables shewing the height of the apparent above the true level for every hundred yards of distance on the one hand, and for every mile on the other, have been constructed. (See *Dr. Hutton's Mathematical Dictionary*, art. *Level*.)

3063. *The operation of levelling* is performed by placing poles or staves at different parts or points from which the levels are to be taken, with persons to raise or lower them, according to circumstances, when the levelling instrument is properly applied and adjusted. In describing the more common levels used in agriculture, (2421.) we have also given some account of the mode of using them for common purposes. Their use, as well as that of the different kinds of spirit levels, will be better acquired by a few hours' practice with a surveyor than by any number of words: and indeed in practice, whenever any very important point or series of levels are to be taken, it will commonly be found better to call in the aid of a land surveyor than to be at the expense of implements to be seldom used, and by which errors might easily be made by a very skilful person not accustomed to their frequent use.

3064. *Levelling to produce an even line* (fig. 420.), as in road making, whether that line be straight or curved in direction, can only be determined on an irregular surface by measuring down from an elevated level line ( $a$ ), or from level lines in parallel di-

420

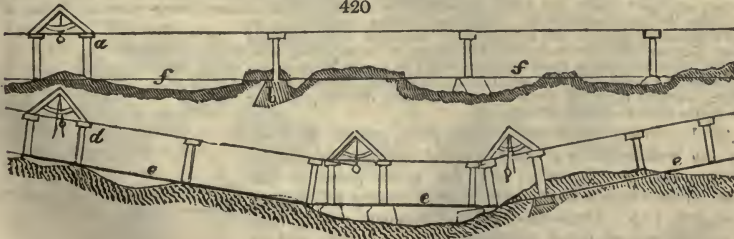

rections, and so transferring the points by horizontal levels to the proper line. Straight rods are the ready means of measuring down, and the points must be marked by hil-

locks or hollows (*b*), or by smooth-headed stakes driven into the surface, and protruding above, or sunk under it, according to the obstructions.

3065. *Lines of uniform declivity or acclivity* (fig. 420 *e, c, e*) are readily formed on the same principle. In this and the former case, the common level and the boring pieces (*a* and *d*), with measuring-rods and stakes, are all the instruments required.

### SUBJECT. 3. *Of the Division and laying out of Lands.*

3066. *The division of lands* is one of the most important and not the least difficult parts of the land surveyor's art. In intricate cases, as in the subdivision of large estates or commons, the professional surveyor will generally be resorted to, but it is essential for the land-steward and proprietor, and even for the farmer, or professional cultivator, to know the general principles on which this business is founded. We shall therefore shortly develop these principles from Dr. Hutton's valuable Dictionary, and next offer some general rules of our own, for ordinary cases of dividing and laying out lines.

3067. *In the division of commons*, after the whole is surveyed and cast up, and the proper quantities to be allowed for roads, &c. deducted, divide the net quantity remaining among the several proprietors, by the rule of fellowship, in proportion to the real value of their estates, and you will thereby obtain their proportional quantities of the land. But as this division supposes the land, which is to be divided, to be all of an equal goodness, you must observe that if the part in which any one's share is to be marked off, be better or worse than the general mean quality of the land, then you must diminish or augment the quantity of his share in the same proportion.

3068. *Or divide the ground among the claimants in the direct ratio of the value of their claims*, and the inverse ratio of the quality of the ground allotted to each; that is, in proportion to the quotients arising from the division of the value of each person's estate, by the number which expresses the quality of the ground in his share.

3069. *But these regular methods cannot always be put in practice*; so that, in the division of commons, the usual way is, to measure separately all the land that is of different values, and add into two sums the contents and the values; then the value of every claimant's share is found by dividing the whole value among them in proportion to their estates; and lastly, a quantity is laid out for each person, that shall be of the value of his share before found.

3070. *It is required to divide any given quantity of ground, or its value, into any given number of parts, and in proportion to any given number.* — *Rule.* Divide the given piece, or its value, as in the rule of fellowship, by dividing the whole content or value by the sum of the numbers expressing the proportions of the several shares, and multiplying the quotient severally by the said proportional numbers for the respective shares required, when the land is all of the same quality. But if the shares be of different qualities, then divide the numbers expressing the proportions or values of the shares, by the numbers which express the qualities of the land in each share; and use the quotients instead of the former proportional numbers.

	Ac.	R.	P.
A =	4	2	30
B =	9	1	20
C =	14	0	10
D =	23	1	30
E =	37	2	00
F =	46	3	20
G =	70	1	10
H =	93	3	00
Sum =	300	0	00

*Ex. 1.* If the total value of a common be 25000. it is required to determine the values of the shares of the three claimants A, B, C, whose estates are of these values, 10,000, and 15,000, and 25,000. The estates being in proportion as the numbers 2, 3, 5, whose sum is 10, we shall have  $\frac{25000}{10} = 2500$ ; which being severally multiplied by 2, 3, 5, the products 500, 750, 1250, are the values of the shares required.

*Ex. 2.* It is required to divide 300 acres of land among A, B, C, D, E, F, G, and H, whose claims upon it are respectively in proportion as the numbers 1, 2, 3, 5, 8, 10, 15, 20. The sum of these proportional numbers is 64, by which dividing 300, the quotient is 4 ac. 2 r. 30 p., which being multiplied by each of the numbers, 1, 2, 3, 5, &c. we obtain for the several shares as annexed:

*Ex. 3.* It is required to divide 780 acres among A, B, and C, whose estates are 1,000, 3,000, and 4,000. a year; the ground in their shares being worth 5, 8, and 10 shillings the acre respectively. Here their claims are as 1, 3, 4; and the qualities of their land are as 5, 8, 10; therefore their quantities must be as one-fifth, three-eighths, two-fifths, or by reduction, as 8, 15, 16. Now the sum of these numbers is 39; by which dividing the 780 acres, the quotient is 20; which being multiplied severally by the three numbers 8, 15, 16, the three products are 160, 300, 320, for the shares of A, B, C, respectively.

3071. *To cut off from a plan a given number of acres, &c. by a line drawn from any point in the side of it.*—

*Rule.* Let *a* (fig. 421.) be the given point in the plan, from which a line is to be drawn cutting off suppose 5 ac. 2 r. 14 p. Draw *ab* cutting off the part *abc* as near as can be judged equal to the quantity proposed; and let the true quantity of *abc*, when calculated, be only 4 ac. 3 r. 20 p. which is less than 5 ac. 2 r. 14 p. the true quantity, by 0 ac. 2 r. 34 p. or 71,250 square links. Then measure *ab*, which suppose =

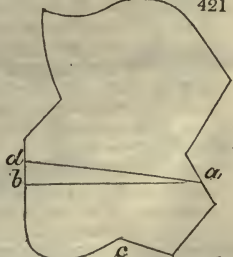

421

1,234 links, and divide 71,250 by 617, the half of it and the quotient 115 links, will be the altitude of the triangle to be added, and whose base is  $a, b$ . Therefore if upon the centre  $b$ , with the radius 115, an arc be described, and a line be drawn parallel to  $a, b$ , touching the arc, and cutting  $b, d$  in  $d$ ; and if  $a, d$  be drawn, it will be the line cutting off the required quantity  $a, d, c, a$ . On the other hand, if the first piece had been too much, then  $d$  must have been set below  $b$ . In this manner, the several shares of commons to be divided, may be laid down upon the plan, and transferred from thence to the ground itself.

3072. *The simplest mode of dividing lands, and that by which the agriculturist will make fewest errors is, by trial and correction.* Thus, supposing a piece of unenclosed land of irregular shape to contain thirty-eight acres and a half, and it is desired to lay it out in three fields, each of the same extent. Take a plan of the field and lay it down on paper; divide it into three parts as near as possible by the eye: then ascertain the contents of one of the outside divisions, which will be either somewhat too little or too much. Suppose it too little by half a rood; then as the length of the straight line of the division is 1000 links, and 1000 links in length and 100 in breadth make an acre, and as half a rood is the eighth of an acre, it follows that by extending the line the eighth part of 100 links, or 12.4 links at both ends, or 24.8 links at one end, the requisite quantity will be added. Then go through the same operation with the projected field on the other extreme of the plot, and this being corrected, the middle field must necessarily be of the exact contents of each of the two others; but to prove the whole, this field also may be tried in the same manner.

3073. *In dividing a field with a view to sowing different crops in certain proportions: say, for example, one acre and a half of common turnip, one acre of Swedish turnip, three quarters of an acre of potatoes, and five acres of pease.* Suppose the field a parallelogram or nearly so, then first ascertain the length of the ridges, and next state the question thus: Such a length being given, required the breadth to give a fourth of an acre; that being the smallest fraction in the proportions to be laid out; then if the length of the ridges be ten chains, the breadth requisite to give a quarter of an acre will be 25 links; consequently a breadth of five times that space will be required for the common turnips; four times for the Swedish turnips; three times for the potatoes, and twenty times for the pease.

3074. *In all more intricate cases, first lay down the plan of the space to be divided on paper, to a large scale, say a chain to an inch; then cover the paper with lines, draw so as to form squares, each square containing a certain number of feet and yards, or say pole each; then on these squares adjust the figure, whatever it may be: thus, supposing it desired to lay out a thicket of trees on the face of a hill, the outline of which shall resemble the outline of the profile of a horse, dog, or say a human head, and yet shall contain only one acre: lay down the outline of the horse or head on a large scale, and divide it into squares; then by trial and correction ascertain what each square must necessarily contain. Say that there are 130 entire squares and 40 parts of squares, making up in all 160 squares; each of these squares must of course contain exactly one pole or 625 links, and their sides the square root of that number or 25 links. From these data it is easy to lay down the figure with perfect accuracy.*

3075. *The laying out lines on lands, for the purposes of roads, fences, &c. requires to be well understood by the agriculturist. On a plain surface, the business of tracing straight lines is effected by a series of poles, so placed that the one nearest the eye conceals all the rest. Where a straight line is to be indicated among objects or inequalities, not more than fifteen or twenty feet high, its plan or tract on the earth ( $a, b, \text{fig. 422.}$ )*

422

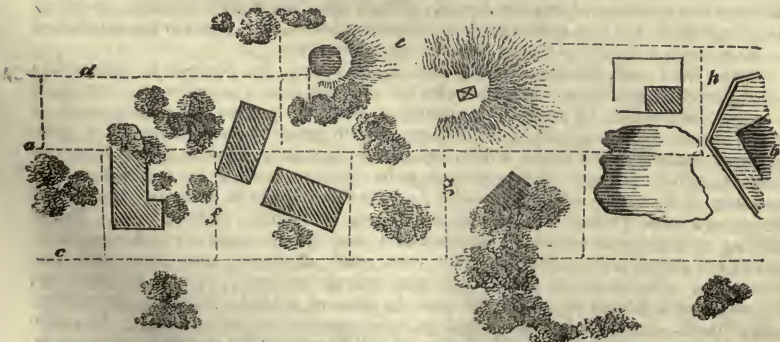

may be found by the use of poles, a few feet higher than the elevation of the obstructions, the director being placed on a step-ladder, or other elevation at one end. Where this method

cannot be adopted on account of the height of the inequalities, the line must either be formed along the summits of these inequalities, which may be done if they are houses, hills, or trees; or parallel lines (*c, d, e*) formed where practicable, and the main line found by off-sets (*f, g, h*) from those collateral lines at such places as are suitable. A third method, but one not always perfectly accurate, is to take a plan of the field or scene of operations, and on this to set out the proposed line; then by ascertaining its bearings and distances relatively to the obstructions, it may be transferred from the paper to the ground. In carrying straight lines through woods, lanterns have been used; but a much more correct method is to elevate poles above the surface of the wood.

3076. *Continuous lines* may always be made perfectly straight, however irregular the surface, by following the same parallel as indicated by points of the compass; or by the shadow of the operator during sunshine. If the needle does not move, or the shadow of the spectator be always projected at the same angle to his course, the direction in which he walks, in either case, must be straight. The mode of forming right lines in such circumstances being understood, the formation of right lined figures is merely a repetition of the process, uniting each side by the required angle.

3077. *Curved lines* on irregular surfaces are in general only to be laid down by the previous establishment of straight lines; first, leading straight lines, and next secondary straight lines, which shall form skeletons to the curves. A second mode and on a large scale, by much the most certain, is to find the leading points of the curves, by triangles from a known base or known bases; but as both modes are rare, they need not be enlarged on.

#### SUBJECT. 4. *Of estimating Weight, Power, and Quantities.*

3078. *Ascertaining the weight of objects* is a part of agricultural knowledge, no less necessary than that of measuring their superficial or solid contents. In all ordinary cases, as of grain, roots, bundles of straw, bushels of lime, &c. this is best done by a common steelyard, suspended from a beam or a triangle of three posts. Cart or waggon loads are weighed on those well-known platforms sunk in the ground at toll gates; or sometimes by steelyards on a very large scale. Cattle are weighed by machines of a particular kind, which have been already described (2461. to 2463.). The weighing of cattle and grain chiefly concerns the farmer, and is of consequence, in the first case, to ascertain the progress of fattening animals, or the weight of those ready for the butcher; and, in the second, to determine the quantity of flour that may be produced from a given quantity of grain.

3079. *Estimating the quantity of power requisite to draw any implement or machine*, is performed by the intervention of the draught machine already described (2460.), between the power and the implement. It would not be difficult to construct all agricultural implements with a fixed draught machine and index, which would at all times, when they were at work, shew the amount of power employed in moving them; but such an arrangement would be of little use.

3080. *Estimating the quantity of work* which servants and cattle ought to perform in a given time, is an art that ought to be familiar to every agriculturist. In general no absolute rule can be laid down, because so much depends on soils, roads, cattle, and other circumstances; but in every particular case the rate or market price of labor per day being given, and the quantity of work ascertained which a man can fairly perform in a certain time, a rate per yard, pole, or acre, or per solid quantity, if materials are to be moved, can easily be determined on. A farmer should know by memory the number of ridges or of single furrows, or bouts, which it requires to make an acre on every field of his farm. This will aid him in every operation that requires to be performed on these fields — the quantity of manure, seed, ploughings, harrowings, hoeings, mowing, reaping, raking, &c.; as well as produce, whether of corn, hay, roots, or the number of cattle or sheep that may be grazed there for any given time.

3081. *Road work, ditching, hedging, draining, trenching, &c.* ought to be subjected to similar calculations, so as if possible to let out all work not performed with the master's own men and cattle, by contract or quantity, instead of by time. As spade work is nearly the same in most parts of the country, certain general rules have been laid down by canal contractors and others, which, though seldom strictly followed up, yet it may be useful to know. Thus in moving ground, as in digging a drain, or the foundations of a building, if the soil is soft, and no other tool than the spade is necessary, a man will throw up a cubic yard of 27 solid feet in an hour, or 10 cubic yards in a day. But if picking or hacking be necessary, an additional man will be required; and very strong gravel will require two. The rates of a cubic yard, depending thus upon each circumstance, will be in the ratio of the arithmetical numbers 1, 2, 3. If, therefore, the wages of a laborer be 2s. 6d. per day, the price of a yard will be 3d. for cutting only, 6d. for cutting and hacking, and 9d. when two hackers are necessary. In sandy ground, when wheeling is requisite, three men will be required to remove 30 cubic yards in a day, to the distance of 20 yards, two filling and one wheeling; but to remove the

same quantity in a day, to a greater distance, an additional man will be required for every 20 yards.

3082. *To find the price of removing any number of cubic yards to any given distance:* Divide the distance in yards by 20, which gives the number of wheelers; add the two cutters to the quotient, and you will have the whole number employed; multiply the sum by the daily wages of a laborer, and the produce will be the price of 30 cubic yards. Then, as 30 cubic yards is to the whole number, so is the price of 30 cubic yards to the cost of the whole. *Example.* — What will it cost to remove 2,750 cubic yards to the distance of 120 yards, a man's wages being three shillings per day? First,  $120 \div 20 = 6$ , the number of wheelers; then  $+ 2$  fillers = 8 men employed, which, at three shillings per day, gives twenty-four shillings as the price of 30 cubic yards; then  $30 : 24 :: 2,750$  and  $24 \times 2,750 \div 30 = 110l$ .

SUBJECT. 5. *Of Estimating the Value of Agricultural Labor and Materials.*

3083. *Estimating the value of work done* is a necessary part of agricultural knowledge, and is founded upon the price of labor and the time of performance. The price of labor is every where determined by the operations of the public, and therefore in any given case can seldom admit of much difference of opinion. In a theoretical view of the subject the proper wages for a laborer in England has been considered for ages, to be a peck of wheat; and that of a horse the amount of his keep, expenses of a year's shoeing, and ten per cent. on his value or cost price at a fair age, added together, and divided by the number of days such horse is supposed to work in a year; this brings the value of the day's work of a horse to something more than once and a half the value of the day's work of a man; so that supposing a laborer's wages two shillings per day, a man and a pair of horses would be worth eight shillings per day. This, however, it must be acknowledged, is a calculation not to be always depended on, as local circumstances continually intervene to alter the proportions. In all cases of valuing labor, therefore, all that the valuator can do is to ascertain the local price, and to estimate from his own experience the time requisite to perform the work.

3084. *In estimating the value of labor and of materials*, considerable difficulty occurs in some departments of agriculture. Thus in valuing fallows and sown crops it is often a nice point to determine satisfactorily the value of the manure or other dressings; and in valuing the tillages or the condition of the arable lands of an out-going tenant, regard must be had not only to the actual number of ploughings a field may have been subjected to, the preceding or current year, but to the position which the state of that field holds in the rotation, and to the value which may still be in the soil of manures or limings given to former crops. Supposing a field fallowed, limed, and dunged in the year 1820, and that when it fell to be valued in the spring of the year 1824, it was drilled with beans on one furrow, it would be no adequate compensation for the tenant to be paid for one ploughing, the beans, and the drilling; the fallow, the dung, and especially the lime given in 1820, must be considered as extending their influence even to this crop, and therefore an allowance ought to be, and generally is made for these three articles, besides the mere value of the labor and seed. What this allowance should be it does not seem easy to determine: land valuers and appraisers have certain rules which they go upon, which are known to few but themselves, but which having ourselves been initiated in the business, we know to differ considerably in different parts of the country. Some calculate that the value of dung extends to the fourth year, and declines in a geometrical ratio, or in the proportion 1, 2, 4, 8. Others limit its effects to three years. Lime is allowed in some places to produce effects for three years only, and in others, especially on new lands, for twelve and fourteen years, and its value is generally supposed to decline in the proportion of 1, 2, 3, &c. Naked fallow is generally considered as of beneficial influence for five years, where it occurs every seven or eight years, and shorter periods in proportion. A crop sown on a single furrow after a drilled crop which has been manured, is considered as partaking of the manure or other dressings according to the extent to which these have been given, and generally in the same ratio as in manured fallows.

3085. *In estimating the value of materials alone*, the first thing is to ascertain their quantity, and the next their market price. Thus, in the case of heaps of manure, the cubic contents must first be found, by finding the area of the base of the heap, and its mean depth, and multiplying the one into the other; next the quality of the material must be examined, and the expense of purchasing it in the nearest town or source of purchase, with the addition of the expense of carriage to the spot where it lies. Ricks, whether of straw or hay, are valued in a similar manner. Crops in a growing state are valued according to what they have cost, including tillage, manures, seed, rent, taxes, and other out-goings, and ten per cent. on the outlay of capital; crops arrived at maturity are valued according to their quantity and quality, deducting the expenses of reaping, threshing, &c. In coal countries an allowance is made for thorn-hedges which

have been newly cut; but the reverse is the case where fuel is scarce, an allowance being made according to the quantity of brush or lop on the hedge. The lop of pollards and prunings of hedge-row trees to a certain height, is generally valued to the tenant; but a better mode is for the landlord to take the timber-trees entirely under his own management

3086. *In valuing live-stock*, a variety of circumstances require to be taken into consideration. The value of all young animals may be considered as prospective; the chief value of others depends on their breeds; of some, on accident or fashion; and of fed animals on their actual value to the butcher. Draught cattle may be valued on an abstract principle, derived from the probable value of their lives and labor; but in general nothing is to be depended on but a knowledge of the market price, and this ought to be familiar to every valuator.

3087. *In valuing buildings*, regard must be had to their absolute use as such, and to their effect on the value of surrounding property. In the case of buildings merely useful as farmhouses, it will sometimes happen that more buildings are erected than the most approved mode of husbandry requires, as in the case of large barns and granaries, ornamental pigeon-houses, &c.: these can be valued on no other principle than that of the value of the materials, supposing them taken down; and in regard to an in-coming tenant they are to be considered as a drawback, rather than as of any value.

3088. *In valuing orchards, hop-grounds, osier plantations*, and similar crops, it is usual for the first two or three years after planting, to allow only the cost, rent, all outgoings, and ten per cent. on their amount; but afterwards, the trees and plants having taken with the soil, and promising abundant crops, they are valued prospectively in the mode in which we shall next describe as applied to young plantations of timber-trees.

3089. *In valuing young plantations*, when they are only of two or three years' growth, it is usual to proceed as in valuing orchards; but afterwards, when their growth is becoming rapid, and the fences in a sufficient state, the plantation is valued prospectively in the following manner:—The contents being known, and the number of healthy young trees per acre ascertained, then their value at any distant period, not exceeding twenty or twenty-five years, is estimated; and whatever sum that estimate amounts to, the present value of that sum will give an idea of the value of the plantation, allowing liberally for accidents to the trees, and other unforeseen circumstances. Thus, suppose a plantation of oaks, intended as copse, or actually established as such, to have grown four years, its present value would be next to nothing; but if arrived at its twentieth year, it would fetch fifty pounds per acre. Then the question is, required the present value of fifty pounds due sixteen years hence, the market price of money being five per cent. ? and this, according to any of the modern annuity tables (say *Bayley's* 4to. 1808. tab. iv.), is 2*l.* 18*s.* This principle is applicable to all kind of valuing by anticipation; and there is no other mode of valuing applicable to young plantations.

3090. *In valuing saleable trees*, their number per acre, or their total number, being ascertained, an average value must be made of each tree, according to its worth as fuel, timber, fence-wood, bark for the tan-pit, and other particulars, due allowance being made at the same time for the expenses of felling, cutting up, sorting, carriage, &c. The usual practice in this case, as well as in the valuation of copse-woods, will be given in treating of wood-lands in the succeeding PART of this work.

3091. *In valuing fields for rent*, regard must be had to their soil and subsoil as of the greatest importance; next to their aspect, form, length, and style of ridges; and, lastly, as to the sort of crops or rotation which may be followed on them, and their state of culture. Supposing the valuator to decide in his own mind as to the rotation, his next business is to calculate the expense and produce of the whole course; and after deducting all expenses whatever, and ten per cent. per annum on the capital employed, the balance may be considered as the rack rent which such a field may afford.

3092. *In valuing a farm for rent*, each field must be valued separately in the manner above stated, and a particular rent per acre determined for each field, as well as an average rent for the whole farm. In some cases it is customary to value the farm buildings, dwellings, yards, gardens, &c. but when that is done, a sum in proportion to their value is deducted from the supposed profits as household and other expenses, so that no advantage is gained by it. It is by means of those buildings, threshing machine, and other conveniences, that so much can be paid for each field, and therefore to pay for the buildings, and pay also for their advantages, would be unjust. It must be further obvious, that a great variety of other considerations must be taken into account before even the value of a single field can be ascertained, such as distance from markets, roads, parochial and country towns, price of labor, &c. But after all, it is seldom that land is taken or let on such valuations; rent, like price of every kind, depending more on the quantity of land in the market, and the number of tenants in want of farms, than on the real value of land. This, indeed, often tends to the ruin of farmers, by obliging them to give higher rents than the land can bear; but the same thing takes place in every other trade or profession.



3093. *The amount of the rent of lands* is commonly determined in money alone; but owing to the fluctuations in the value of this commodity, rents are in some places made payable partly in money, and partly in corn, (or beef or wool in some cases,) or in money, and the money value of a certain quantity of produce per acre. In some cases the money value of the produce is determined by its price in the district for the current or preceding year; and in other cases by an average of the money price for the preceding three, five, or seven years. This plan has, within the last seven years, been adopted in many parts of Scotland, and been generally approved of, both by landlords and tenants. There is no plan that will in every year be perfectly equitable, and for this reason many consider the money rent as on the whole the simplest and best, as it certainly is that which occasions less trouble to all parties.

3094. *The valuation of leases* well deserves the study of the culturist, and especially of the farmer, who may often wish or find an opportunity of purchasing a renewal of his lease, or have occasion to dispose of an improved rent, or in other words, sub-let his farm at a profit. It is customary, in many parts of the kingdom, for landlords to compound with their tenants, by accepting a sum of money paid down in place of advancing the rent at the expiration of a former or a current lease. To be able to point out the exact amount of the sum to be paid in any transaction of this nature, according to the annual profit, and the number of years for which the lease is to be granted, must obviously be particularly useful. The valuation of church leases and of college lands, is of not less importance, as these for the most part are let on twenty-one years leases, renewable for seven years longer at the end of every seven years; or on leases for lives, every life being renewable as it drops, for a certain sum to be determined according to the age of the life to be put in, and the value of the lands.

3095. *The principle on which all calculations, as to the value of leases, is made*, is as follows: a sum being fixed on, which is considered or agreed on as the worth or profit which the tenant has in the lease, and the time which the lease has to run, or for which it is to be renewed being agreed on, then the purchaser of the lease or of the renewal pays down to the seller the present value of an annuity equal to the profit or worth, reckoning money at its market price, or at what is called legal interest. Thus, should it be suitable to the convenience of both parties to renew a lease of twenty-one years, of which only one year had expired, the tenant ought to pay the landlord 7*s.* 2*d.* for every pound of profit he has in the lease. Should it be asked how the tenant is to pay the landlord only 7*s.* 2*d.* out of each pound that he had of profit in the one year that has elapsed, it is answered, that the landlord had no right to receive the 7*s.* 2*d.* until the expiration of twenty years, which is the number the lease has yet to run; and that this sum of 7*s.* 2*d.* laid out at compound interest, at 5 per cent., payable yearly, would, at the end of twenty years, amount exactly to 1*l.*; so that the landlord has received just the amount of what he was entitled to, and no more.

3096. *Or, as the most customary period at which to renew*, during the currency of a lease of twenty-one years, is when seven years have elapsed, then the exact sum that ought to be paid for adding seven years will be 2*l.* 18*s.* 5*d.* for every 1*l.* of annual profit, because 2*l.* 18*s.* 5*d.* laid out at compound interest, will, in twenty-one years, the length of lease obtained by paying it, amount exactly to 7*l.*, the profit that would have accrued to the landlord during the seven years of renewal.

3097. *The method of determining all questions as to the renewal of leases, sale of profits on sub-leases, &c.* is easily learned from the common books of arithmetic; and the value of lives from tables composed from a long series of observations in different places, as at London, Northampton, &c. But practical men can seldom have recourse to so tedious a method as calculating for themselves, by which, for want of daily practice, serious errors might be made. They therefore have recourse to published tables on the subject, by which the most intricate questions of this kind may be solved by the humblest individual who can add and subtract, in a few minutes. The tables in most repute at present are *Bailey's Tables for the purchasing and renewing of Leases*, 1807; *Clarke's Enquiry into the Nature and Value of leasehold Property and life Annuities, with many Tables*, 1806; and there is a useful pocket compendium entitled, *Tables for the purchasing Estates, Leases, Annuities, and the renewing of Leases*, by W. Inwood, London, 1811. There is a recent work on *The Valuation of Rents and Tillages*, by J. S. Bayldon, which is the best of its kind extant.

3098. *The questions* following, and others of similar importance to agriculturists, and indeed to all men of property, may be answered from these tables.

*Question.* What sum must be paid down for a lease for twenty-one years to make five per cent. and get back the principal?

*Answer.* Twelve years and three-quarters purchase of the annual rent.

*Q.* What sum ought to be paid for a lease granted on a single life aged thirty, to make four per cent. and get back the principal?

*A.* Fourteen years and three quarters purchase of the clear annual rent.

*Q.* What sum ought to be paid for a lease held on two lives of twenty and forty years, but determinable on the death of either, to pay five per cent. and get back the principal?

*A.* Ten years purchase.

Q. What sum ought to be paid for a lease held like the last on two lives of twenty and forty years, but to continue during the existence of either of the lives, to pay five per cent. and get back the principal?

A. Sixteen years purchase.

Q. What sum or fine ought a tenant to give for the renewal of four years lapsed in his lease of ten years, in order to make seven per cent. interest of his money and get back the principal?

A. Two years and a quarter purchase of the annual value or clear profit which he makes of the holding.

Q. A farmer is offered a lease during the life of a person aged thirty years, to what term certain is that considered equivalent?

A. Twenty-one years.

Q. In a lease held originally on three lives, but of which one is dropped, the ages of the lives in possession being forty and sixty; what sum ought the tenant to pay for passing in a new life, aged fifteen, in order to make five per cent. interest and return the principal?

A. Three years and a quarter of the clear improved rent or profit which he has in the lease.

Q. A has an estate in land and houses let for 105*l.* per annum. He wishes to sell the reversion of this rent after the death of his father aged sixty-five years, his wife aged forty-one, and himself aged forty-three; required the sum that must be paid by the purchaser?

A. The father's life is worth ten years; the wife's twenty; and his own eighteen years; say twenty-one years; as the probable period at which the property will fall to the purchaser of the reversion. Then the value to the latter is the present value of an annuity of 105*l.* a year, due twenty-one years hence. This, calculating interest at 5*l.* per cent., is 761*l.* 5*s.* and at 4*l.* per cent. 1155*l.*

3099. In the valuation of freehold landed property, the clear annual value must first be ascertained by a minute examination of every part of the estate, and of every internal and external circumstance affecting it. An estate may be neglected, or underlet on short or long leases, or overlet by means of bonuses, or favorable conditions given to the tenants; or it may be burdened by parochial taxes; these, and a number of other circumstances require to be taken into consideration in determining its annual value. The annual value is often different from the annual produce, and therefore, in making a calculation of the sum to be paid for an estate, the difference between them forms an essential part of the data. Thus an estate of the annual value of 100*l.* may be let on a lease of which fourteen years and a half were unexpired for 80*l.*, in which case there must be deducted from the price the present value of an annuity of 20*l.* for fourteen years and a half. Thus if twenty-five years purchase or 2500*l.* was the price agreed on, there must be deducted 200*l.*

3100. In determining the sum to be paid for estates in perpetuity there are no guides of universal application but the state of the market and public opinion. However, a sort of abstract principle has been laid down as applicable to this country, which it may be worth while to notice. N. Kent, a land agent of much experience, says, (*Hints to Gentlemen of landed Property*, &c. 1793. p. 266.) "the want of a criterion to determine the price of estates creates doubt; and doubt impedes the transfer; any thing therefore that can aid the purpose of passing estates from one person to another, with the greater facility, may be properly introduced here." Suppose then that the gradual scale, by way of an outline, be taken up thus: When the funds stand pretty steady at four per cent. the standard of mortgages may be considered at four and a half: the fee simple on the neat return of land ought then to be current at three; copyholds of inheritance upon a fine certain, at three and a half; copyholds with a fine at the will of the lord, at four. This general rule is short, and may be registered in the mind of every man of business. At the same time Kent states, that "nineteen times out of twenty, estates are bought and sold upon round numbers."

3101. In making calculations of the value of estates, the following rules deserve notice. In order to know the number of years' purchase that ought to be given for an estate in perpetuity, according to the several rates of interest which the purchaser may wish to make of his money, it is only necessary to divide 100 by the rate of interest required, and the quotient will shew the number of years' purchase that ought to be given.

3102. With respect to the value of freehold estates, or the gross sum which ought to be paid for the same, Bailey observes, we may either multiply the number of years' purchase, found as above, by the annual rent of the estate, or we may "multiply the annual rent of the estate by 100, and divide the product by the rate of interest which we propose to make of our money; the quotient will be the sum required." For example, the sum which ought to be paid for a freehold estate, of the clear rent of 90*l.* per annum, so that the purchaser may make 4 per cent. interest of his money, is found either by multiplying 25 by 90, which gives 2250*l.* for the sum required; or by multiplying 90 by 100, which produces 9000; and then dividing this product by 4, which gives 2250*l.* as before. The first way is the most expeditious, where the number of years' purchase is an even quantity; but the latter will be found the most ready, where the number of years' purchase is a fractional quantity, or is not precisely known. Thus, the gross sum which ought to be paid for a freehold estate of the clear rent of 150*l.* per annum, in order that the purchaser may make 7 per cent. interest of his money, is found by multiplying 150 by 100, which produces 15,000, and then dividing this product by 7, which gives 2142*l.* 17*s.* 2*d.* for the sum required: now if, in answering this question, we had begun by finding the number of years' purchase which ought to have been given for the same, the process would have been rendered much more tedious and intricate.

3103. *In order to find the clear annual rent which a freehold ought to produce, so as to allow the purchaser a given rate of interest for his money, we must “multiply the gross sum paid for the same, by the given rate of interest, and then divide the product by 100; the quotient of which will be the annual rent required:”* thus, if a person gives 5940*l.* for a freehold estate, and he wishes to make 6½ per cent. interest of his money, then 5940 multiplied by 6·5, will produce 38610·0, which, divided by 100, will quote 386·100, or 386*l.* 2*s.*, for the clear annual rent required. Lastly,

3104. *The rate of interest allowed to the purchaser of a freehold, is much more readily and more exactly ascertained than in the case of leases for terms, as we have nothing more to do here than to “multiply the clear annual rent of the estate by 100, and then divide the product by the sum paid for the estate; the quotient will be the rate of interest required:”* thus, if a person gives 2000*l.* for a freehold estate, of the clear rent of 85*l.* per annum, then 85, multiplied by 100, will produce 8500, which, divided by 2000, will quote 4·25, or 4½ per cent. for the rate of interest required.

3105. *The valuation of mines and minerals is not a matter of much difficulty when it extends merely to quarries of stone, lime, chalk, gravel, or other bodies “open to the day,” or worked from the surface. If the quantity is indefinite, then the annual income afforded forms the ground-work; if it is limited, then the joint consideration of the quantity, and the probable time the current demand may take to exhaust it. The valuation of metallic mines belongs to a distinct class of professors known as mineral surveyors, and is a matter foreign to agriculture, which confines itself to the earth’s surface, or at least to the epidermis of its upper crust.*

SUBJECT. 6. *Of the professional Etiquette of Land Surveyors, Appraisers, and Valuers, in making up their Plans and Reports.*

3106. *For protracting rural objects various modes have been adopted by land-surveyors: trees are sometimes shown by small crosses or cyphers, triangles or dots (fig. 423. a); by*

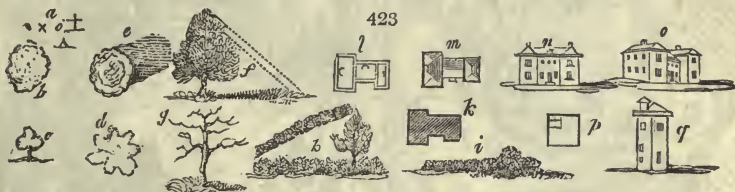

an orbiculate line representing the extension of the branches or head, and a dot in the place of the trunk (*a* and *e*); by the same, with the addition of a shadow, taken when the sun is south or south-west, and his elevation exactly 45°, by which the points of the compass are readily ascertained throughout the plan, and the shape of the head, and the height of the tree exhibited (*e*); sometimes an elevation or profile of the tree is given, either in foliage (*f*), or to show the form of the trunk and branches (*g*), or merely to give a rude idea of a tree (*c*). Hedge-rows, whether with or without trees, are either shown in elevation or profile (*h*), or in vertical profile or bird’s-eye view (*i*). They may be delineated either in skeleton or foliage. Buildings may be shown either in general plan (*k*), detailed plan (*l*), vertical profile of the roof (*m*), elevation (*n*), perspective view (*o*); or a plan may be given (*p*), and a diagonal elevation (*q*) taken and placed opposite the plan in the margin of the map. A pictorial surveyor, who understands perspective, and is desirous of conveying a correct idea of the subject he is to measure and delineate, will readily find expedients for attaining success.

3107. *In protracting elevations and depressions on paper the simplest way is to introduce sections, in dotted or otherwise distinguished lines, to prevent their being mistaken for surface-lines; or in wavy surfaces, figures may be introduced, thus 7 or 4, to denote their elevation above, or depression below, some piece of water, or other surface fixed on as a medium. Some excellent observations on this subject will be found in Major Lehman’s Topographical Plan Drawing, as translated by Lieutenant Sibern, (oblong fol. Lond. 1822), which it is to be hoped will soon be appropriated in the popular books on land surveying, and adopted in practice.*

3108. *Where it is in contemplation to form canals, or other reservoirs or pieces of water, the elevations and depressions or levels must be taken and recorded either by sections or arithmetically with the greatest accuracy; and, in some cases, sections may require to be taken to show particular trees, buildings, the depth of water, or other objects. (fig. 424.)*

3109. *With respect to the elevations and hapes of hills and mountains they are only to be measured correctly by the quadrant and theodolite, in the hands of regular land surveyors. Their shape and dimensions are laid down in maps in the same manner as those*



of smaller deviations from the flat surface. Inaccessible dimensions of height, as of trees or buildings, are obtained by the quadrant, or by relative comparisons of shadows; of depth, as of water or wells, by rods; of breadth or length, by finding the two angles of a triangle whose base shall be in one extremity of the distance; and apex in the other. These, and many other equally simple problems in trigonometry, need not be enlarged on, because they must be supposed to form a part of general education.

3110. In portraying the general surface of land estates, different modes have been adopted by modern land surveyors. The first we shall mention is the old mode of giving what may be called the ground-lines only; as of roads, fences, water-courses, situations of buildings and trees. (fig. 425.) This mode has no other pretensions than that of accuracy of dimensions, and can give few ideas to a stranger who has not seen the property, beside those of its contents and general outline.



3111. In the second, elevations of the objects are added to these lines; but which, in crowded parts, tend much to obscure them. (fig 426.) This mode is perhaps the best calculated of any to give common observers a general notion of an estate; more especially if ably executed. Very frequently, however, this mode is attempted by artists ignorant of the first principles of drawing, optics, or perspective, and without taste.

427



3112. In the third, a *vertical profile*, or geometrical bird's-eye view, that is, a bird's-eye view in which all the objects are laid down to a scale, is presented. In this the upper surface of every object is seen exactly as it would appear to an eye considerably elevated above it, and looking centrally down on it. (*fig. 427.*) This mode, properly executed, is calculated to give a more accurate idea of the furniture or surface-objects of an estate than any other; and if the declivities be correctly indicated, and the shade of the hollows and eminences to be laid on with reference to some medium elevation, referred to or illustrated by sections, taken in the direction of indicated lines (*a...b.*), it will give an equally correct idea of the variations of the ground. In short, it is the best mode for most purposes, and is now coming into general use.

3113. A *very complete method* of giving the plan of an estate, is to adopt the profile manner and include such a portion of the plans of the adjoining estates or country as shall be contained within a circle of moderate extent (*fig. 428.*), the centre of which may

428



be the centre of the demesne-lands, family-mansion, or prospect-tower. Around a map so formed, the distant scenery, as seen from the roof of the house, or prospect-tower, may form a panoramic circumference, or margin of prospects. (*fig. 428.*) In all these modes, dimensions and contents are given or obtainable along with effect; in all those which follow, effect or general appearance only is obtained.

3114. The *natural bird's-eye view* is intended to give a general idea of the external appearance of an estate. In this the eye of the spectator is supposed to be considerably elevated above the centre of the estate, and all the objects are portrayed exactly as they would appear to him in that situation; largest in the centre, and gradually diminishing to the circumference of the circle of vision. In such a delineation, parts of other adjoining estates may often require to be included, in order to complete the circle; but these are necessary to the general idea, and can easily be distinguished from the principal property by minute marks on the delineation.

3115. In the *panoramic view*, the delineator supposes himself placed on an eminence, as the roof of the mansion, where central, and looking round on all that he sees on every side. Where there is a prominent hill; or where the mansion is on an eminence, this is a very desirable mode of giving a general idea of a domain, and by the aid of hori-

zontal lines, and lines converging to them from the centre of vision, some idea may be had, on flat surfaces at least, of the relative heights and distances of objects.

3116. A simple mode is to give a *general view*, or *distant prospect* of the estate, or its principal parts (*fig. 429.*), as seen from some elevated conspicuous hill, building, or object near it; or if the estate, as is frequently the case, is situated on the side of a hill, or range of hills, a situation on the plain, or flat grounds opposite to it, will be sufficient.

429



3117. *In delineating maps* the most durable mode in point of durability is on parchment; but where there is a chance of alterations being made on the estate, as in the lines of roads, fences, streams, &c., it is better to delineate on paper, as the corresponding alterations can be made on the map with greater ease. Such colors as are stains, and do not wash out, are proper for maps and plans on parchment; but where alterations may require to be made, or where shadows or any thing like picturesque effect is to be attempted, water colors alone must be used. To delineate estates and plans of every kind in a beautiful and expressive manner, much depends on having the very best instruments and colors, and in knowing how to use them. The sight of good models is also an important matter, and for this we may refer to Horner's elegant work, *The Art of delineating Estates*, 1813; and the very scientific work of Lehman, already mentioned (p. 487.).

3118. *In the writing or printing* on maps, great want of taste is often displayed. No principle can be more obvious than that the name of a thing, or the ornaments of an object, should not be made more conspicuous than the theory or object itself. Yet this rule is constantly violated in plans of estates by the large ornamental writing or print interspersed in and around them; conspicuous blazonry of the name of the estate and its owner at some corner, and of the compass and scale in others. All these adjuncts should be kept in due subordination to the main delineation.

3119. *Models* of every mountainous estates will be found preferable to any description of maps, or views, for giving a correct idea of them. Such models might be formed in plaster of Paris, wax, or various other materials, and colored after nature.

3120. *Reference books* are essential accompaniments to maps or models, and are of various kinds. Sometimes they merely contain the names and contents of the fields or other parts or divisions, with the state of culture or condition in which they are. In other cases the soil and subsoil are described, but in the most complete cases each farm is described, together with the history of its occupation or improvement under the following or similar heads: — Name, parish, extent, boundaries, when first enclosed, how let and managed hitherto, to whom and for how much let at present, description of the farmery and house, contents, fences, trees, ponds, soil, subsoil, surface, expense, &c. of each field; number of timber trees on the farm, copse woods, and various matters. In addition to such a description as the above, some add in the reference book a separate map of each farm, which renders the whole very comprehensive; and as nothing can be more interesting than the contemplation of a man's own property on all sides, and in every possible bearing, these books are generally valued above all others by country gentlemen.

3121. *The valuations of farming stock, tillage, and leases*, being of temporary use, are made out with little form. In most cases the value of particular articles is not given, but only an enumeration of them, and the sum total. The valutors have the separate values in their private memorandum books; and in cases where two valutors are employed, one on each side, if an umpire is obliged to be called in, in consequence of disagreement, then the parties have reference to their notes. In some cases of valuations by two parties, the umpire being appointed beforehand, accompanies the valutors, hears their

discussion on each article as it comes under review, and decides any difference that may occur as they go on. This is considered the best mode, and is that generally adopted in the case of valuations made by order of the Court of Chancery.

3122. *In making up valuations for purchasing or selling estates*, a report is generally required to accompany the valuation, stating the ground on which it is made. Such a report embraces a great variety of objects according to the nature and extent of the property, and ought to be drawn up in a clear and systematic manner, with such a table of contents and an index as may render it of easy reference.

#### SECT. II. *Operations of Order and Management.*

3123. *The business of agriculture*, whether in the management of extensive estates or the culture of single farms, requires to be conducted in an orderly and systematic manner. For this purpose a certain establishment of operators, a certain style of books of accounts, and great attention in all commercial transactions, may be considered the fundamental requisites.

3124. *The establishment of co-operators and servants*, must depend on the extent of the subject of management. An extensive landed estate, containing besides farming lands, woods, quarries, mills, mines, waters, manorial rights, game, and villages, will require a series of subordinate managers; but in general a steward as a head manager, a steward's clerk or assistant, or in some cases a local steward, are all the managers that are requisite; the subordinate care of quarries, woods, game, &c. being performed by a quarryman, forester, gamekeeper, or by common servants of tried fidelity.

3125. *The gradation of operators required on farms*, depends on their size. Whenever the master does not labor himself, a foreman or operator having some charge is requisite, and in very extensive cases where there is a considerable extent of grazing ground as well as tillage lands, a head ploughman and a head herdsman will be found advantageous. There should also be a confidential laborer, or *headman of all work*, to superintend and accompany women and children in their operations, as in hoeing, weeding, planting potatoes, &c. The grand point to be aimed at by the steward of an extensive estate, and the occupier of a large farm, is to hit on the proper number of sub-managers; and to assign each his distinct province, so as the one may never interfere with the other. Having attained this, the next thing is to keep the whole machine in regular action, to keep every man, from the lowest operator to the highest, strictly to his duty. All operators ought to be adequately remunerated, and it is better in general to pay a liberal price and require vigilant, skilful, and active exertion, than to cheapen labor, and so encourage indolence and bad execution. For the lower class of laborers, especially such as are hired by the year, it will often be necessary to attend as well to the food they eat, as to their constancy at work. In the case of farm servants, for example, it will generally be found preferable to board and lodge single men, than to substitute a sum of money, which they will in many cases either save or spend, otherwise, than so as to strengthen their bodies. Where labor is done by the job, all that is requisite is to see that it is done well, and according to agreement; and this, as we have already observed, is the best mode wherever it can be adopted.

3126. *Orderly conduct in the lower classes of workmen*, is a point to which we would wish particularly to direct the attention of the bailiff and farmer. Regularity in their hours, neatness and cleanness in their dress; punctuality in cleaning and putting away in the proper places their implements of labor or harness; humanity to working, and other animals; decency in general deportment and conversation, and ambition to excel in their particular department. Neatness and order, whether on an estate, a farm, a stable, a dwelling-house, or in a man's dress and manner, forms an index to every thing else. Estates and farms where these qualities prevail, are always well-managed and cultivated; a neat and clean stable is a sure sign of well-conditioned horses, and of economical feeding; a dwelling-house, with neatness around and within, is an index of comfort and peace; and a decently dressed and well behaved man or woman, are sure to be approved, whatever may be their station.

3127. *The necessity of order and neatness* we are most anxious to impress on the minds of all descriptions of masters and managers. Order, it has been well observed, is "Heaven's first law." It is, indeed, the end of all law: without it, nothing worth having is to be attained in life, even by the most fertile in resources; and with it much may be accomplished with very slender means. A mind incapable of an orderly and regular disposition of its ideas or intentions, will display a man confused and disorderly in his actions; he will begin them without a specific object in view; continue them at random, or from habit, without knowing well why, till, some accident or discordant result puts an end to his present progress, unman's him for life, or awakens reflection. But a well-ordered mind reflects, arranges, and systematizes ideas before attempting to realize them, weighs well the end in view, considers the fitness of the means for attaining that end, and the best mode of employing these means. To every man who has the

regulation and disposal of a number of servants, this mode of orderly arrangement is essentially necessary in order to reap the full effects of their labors; and to no man is it of more importance than to agriculturists, whose cares are so various, and the success of whose operations, always connected with, and dependant on living beings, depends so much on their being performed in the fitting moment.

1318. *Propriety* relates to what is fitting and suitable for particular circumstances; it is the natural result of an orderly mind, and may be said to include that part of order which directs the choice and adaptation of means to ends, and of ideas and objects to cases and situations. It belongs to order for a master to allow workmen proper periods for rest and refreshment; propriety dictates the time and duration of these periods, and prudence suggests the wisdom of departing as little as possible from established practices. Decorum is the refinement of propriety.

1319. *Neatness*, as opposed to slovenliness, is well understood; it consists in having every thing where it ought to be; and in attending to the decorum of finishing operations, and to minute things in general.

1320. *As maxims of order and neatness* which ought to be continually present to the mind both of masters and servants, we submit the following:

1311. *Perform every operation in the proper season.* The natural, and therefore the best indications for the operations of sowing and reaping, transplanting, &c. are given by the plants themselves, or by the progress of the season as indicated by other plants. But there are artificial kalendars or remembrancers, the use of which is to remind the master of the leading crops and operations of culture and management throughout the year. But, even if such books were made as perfect as their nature admits of, still they are only calculated to aid the memory, not to supply the place of a watchful and vigilant eye, and habits of attention, observation, reflection, and decision. Unless a steward or farmer has these, either naturally, or partly natural and partly cultivated, in a considerable degree, he will be but little better than a common laborer as to general management and culture of garden scenery.

1312. *Perform every operation in the best manner.* This is to be acquired in part by practice and partly also by reflection.

1313. *Complete every part of an operation as you proceed.* This is an essential point in field operations, and though it cannot always be attended to, partly from the nature of the operation, partly from weather, &c. yet the judicious farmer or bailiff will keep it in view as much as possible.

1314. *Finish one job before you begin another.* This advice is trite, but it is of great importance; and there are few cases where it cannot be attended to.

1315. *In leaving off working at any job, leave your work and tools in an orderly manner.*

1316. *Attend strictly to the hours of commencing labor, and equally so to those of leaving off, unless extraordinary exertion is required.*

1317. *Whenever extraordinary exertions are required, extraordinary indulgences or rewards must be given as compensations.*

1318. *A regular system of accounts* is an obvious part of order and correctness; and it is equally obvious that the extent to which this must be carried, will depend on the subject of management. In the case of extensive landed estates, the regular set of books usual in mercantile concerns becomes requisite, with the addition of some, as a forest-book, time-book, &c. rendered necessary by particular departments of the subject. On small farms, on the other hand, some memorandum-books, a cash-book, and a ledger are all that will be found necessary. Our business here is to give the form of the time-book, which is or may be common to every department of agriculture and scale of management, though most necessary for bailiffs, where a number of day labourers are employed on improvements. In giving the practice of the different branches of agriculture, the books peculiar to each will be described.

1319. *The time-book* is a large folio volume, ruled so as to read across both pages, with columns titled, as in the specimen annexed. In this the bailiff or master inserts the name of every hand; and the time in days, or proportions of a day, which each person under his care has been at work, and the particular work he or she has been engaged in. At the end of each week the bailiff or master sums up the time from the preceding Saturday or Monday, to the Friday or Saturday inclusive; the sum due or to be advanced to each man is put in one column, and when the man receives it he writes the word *received* in the column before it, and signs his name as a receipt in the succeeding column. The time-book, therefore, will show what every man has been engaged in during every hour in the year for which he has been paid, and it will also contain receipts for every sum, however trifling, which has been paid by the bailiff for rural labor. In short, it would be difficult to contrive a book more satisfactory for both master and servant than the time-book, as it prevents, as far as can well be done, the latter from deceiving either himself or his employer, and remains an authentic indisputable record of work done, and of vouchers for money paid during the whole period of the bailiff's services.



3140. *Time-Book*. 1824, Sept. 8th to 15th. Time, Expense, and Occupation of hired Servants and Labourers employed at Longlands, under the Bailiff, A. D.

Sept Names.	Time.							Rate per Day.	Amount per Day.	Advances on Account, Jobs, &c.		Receipts and Signatures.		Saturday.	Daily Occupation.							Remarks.
	8.	9.	10.	11.	12.	13.	14.			15.	L.	s.	d.		L.	s.	d.	Sunday.	Monday.	Tuesday.	Wednesday.	
H. Todd	Foreman of the ploughmen, hired by the year.							0	0	0	1	5	0	Recd. 1	5	0	H. Todd.	At church, and reading at home. On a visit.	Carting oats from 2053.	In the fallow field No. 7.	In the fallow field No. 8.	There have been only two days of sunshine this week, when the thermometer was at 50 deg and 54 deg. The day was cloudy and cold. The thermometer not above 48 deg. The fallows work well, and the crop sown with the usual. Crop now half got in.
J. Moor	Ploughman hired by the year.							0	0	0	1	5	0	Recd. 0	16	6	J. Greig.	At Church, and reading at home. On a visit.	Carting wheat from Peter's piece. At the cart. Stooking wheat.	In the fallow field No. 7.	Carting lime. Carting lime to No. 8.	There have been only two days of sunshine this week, when the thermometer was at 50 deg and 54 deg. The day was cloudy and cold. The thermometer not above 48 deg. The fallows work well, and the crop sown with the usual. Crop now half got in.
J. Greig, Ploughman.	1	0	4	1	1	1	1	5½	3s. 0d.	0	16	6	Recd. 0	15	0	J. Red.	At Church, and reading at home. On a visit.	Carting wheat from Peter's piece. At the cart. Stooking wheat.	In the fallow field No. 7.	Carting lime. Carting lime to No. 8.	There have been only two days of sunshine this week, when the thermometer was at 50 deg and 54 deg. The day was cloudy and cold. The thermometer not above 48 deg. The fallows work well, and the crop sown with the usual. Crop now half got in.	
J. Red, R. Hill, do.	1	0	1	1	1	1	1	6	3s. 6d.	0	15	0	Recd. 1	6	6	R. Hill.	At Church, and reading at home. On a visit.	Carting wheat from Peter's piece. At the cart. Stooking wheat.	In the fallow field No. 7.	Carting lime. Carting lime to No. 8.	There have been only two days of sunshine this week, when the thermometer was at 50 deg and 54 deg. The day was cloudy and cold. The thermometer not above 48 deg. The fallows work well, and the crop sown with the usual. Crop now half got in.	
Ann Hall	1	0	1	1	1	1	1	6	1s. 0d.	0	6	0	Recd. 0	6	0	A. Hall.	At church in the evening.	Sifting in the barn.	At the cow and the cow house.	Set a hen with nine eggs.	Hall, the lime-burner, has got one of the new kilns nearly completed. Cow Charlotte died on Thursday even ing.	
Fox & Co. Laborers by the job.								5	0	0	5	0	0	Recd. 5	0	0	Fox & Co.	At the new road at Bawdry.	At the new road at Bawdry.	At the new road at Bawdry.	There have been only two days of sunshine this week, when the thermometer was at 50 deg and 54 deg. The day was cloudy and cold. The thermometer not above 48 deg. The fallows work well, and the crop sown with the usual. Crop now half got in.	
H. Smith Laborer by the job.								1	0	0	1	0	0	Recd. 1	0	0	H. Smith.	Digging drains in fallow field No. 7.	Digging drains in fallow field No. 7.	Digging drains in fallow field No. 7.	There have been only two days of sunshine this week, when the thermometer was at 50 deg and 54 deg. The day was cloudy and cold. The thermometer not above 48 deg. The fallows work well, and the crop sown with the usual. Crop now half got in.	
										Amount	.....	1	17	6	8	11	6	Total	10	9	0	

3141. *In commercial dealings* the agriculturist requires to be particularly vigilant, because the nature of his occupation and pursuits have not that tendency to sharpen his bargaining faculties which is given by a life of trade or manufacture. The purchase of an estate is so weighty a transaction, that few men trust to their own judgment as to value, and legal advice is always taken as to the validity of the title, &c.; but stewards in dealing with timber merchants, workers of quarries, gravel dealers, brick makers, and others, require to be ever on their guard. The farmer and bailiff require particular caution as to marketing, which is an important business, and not to be excelled in but after long experience in attending fairs and markets; learning the various devices of sellers, to deceive or enhance the price of their goods; and of buyers to depreciate what is exposed to sale. It would not be too much to say, that no man goes to market, whether to buy or sell, without carrying with him the intention to deceive. To farmers who deal chiefly in live stock, marketing is by far the most difficult and important part of their business. There are salesmen or brokers indeed for transacting business in behalf of farmers, as there are agents for effecting transfers of landed property; but in neither case is it safe to trust entirely to their judgment and probity. Personal experience in this as in every department of his art, is what ought to be aimed at by every agriculturist.

## PART III.

## AGRICULTURE AS PRACTISED IN BRITAIN.

3142. In the first Part of this work we have endeavored to give a concise view of the actual state of agriculture in every country, with a view to interest the reader in the subject, and prepare him for entering in detail on the elementary principles of the art. In the second Part, these principles and elementary departments of agricultural knowledge, have been developed in successive views of the nature of vegetables, animals, and soils, and the mechanism and science of agricultural implements and operations. As far as these elementary principles go, they are applicable to the agriculture of every part of the world, with the modifications required by different physical and geographical circumstances; but as such an application is not required, in a work designed principally for this country, we limit this part of our work to *the agriculture of Britain*, in its most improved mode of practice. In the extensive sense in which we have applied the term Agriculture, this will include, 1st, the valuation, purchase, and transfer; 2d, the laying out or arrangement; 3d, the improvement; and 4th, the management of landed property; 5th, the hiring and stocking of farms; 6th, the culture of farm lands; and 7th, the economy of live stock and the dairy.

## BOOK I.

## OF THE VALUATION, PURCHASE, AND TRANSFER OF LANDED PROPERTY.

3143. *On the existence of property depends all human improvement.* Personal property is the first acquirement of man; but scarcely any progress is made in civilization till property in land is established and rendered secure. Landed property, indeed, is the basis on which every other material property is founded, and the origin from which it has sprung. The landed estates of Britain, as a species of property, may be considered in regard to tenure, valuation, and transfer.

## CHAP. I.

*Of the different Kinds and Tenures of landed Property, in the British Isles.*

3144. *As landed property is somewhat different as to tenure, in the three United Kingdoms, we shall notice the leading features of each separately.*

SECT. I. *Of the Kinds of landed Property, and its different Tenures in England.*

3145. *Territorial property in England*, Marshal observes, aptly separates into two principal divisions; — namely, into possessory property, or the actual possession of the lands and their appurtenances; and into abstract rights arising out of them.

3146. *Possessory property* comprises, the soil, or land itself; the minerals and fossils it covers; the waters annexed to it; the wood and herbage it produces; and the buildings, fences, &c. thereon erected.

3147. *Abstract rights* are, seigniorial, as chief rents, &c.; manorial, as quit-rents, fines, &c.; prescriptive, as common rights; predial, as tithes; parochial, as taxes.

3148. *Adowson and parliamentary interest* might be added; as they are not unfrequently attached to landed property.

3149. *Possessory property is further liable to analysis*, and to more particular distinctions.

3150. *Freehold.* If lands are held unconditionally, and in full possession, without any other superior than the constitution and laws of the country, they are termed *freehold*; a term which admits of still further distinctions.

3151. *Feefarmhold*. If they are liable to regular and fixed annual payments, beneath their rental value, and without being liable to fine, heriot, or forfeiture, they are *feefarmhold*, or other inferior holding.

3152. *Copyhold*. If they are held of a superior, as part of a royalty, honor, or manor, and are liable to fines, or other outgoing, on account of deaths, transfers, or other circumstances, they are *copyhold*; and are subject to the ancient customs of the royalty, honor, or manor, of which they are respectively a part.

3153. *Leasehold*. If they are held by special agreement for a definite term, whether of lives or years, they are *leasehold*; which admits of various distinctions; namely,

*Long leasehold*, as for a thousand years.

*Life leasehold*, with a fine certain, or under certain limitations, on renewal.

*Life leasehold*, with an uncertain fine; payable to a proprietor or other superior, who has merely reserved a conventional rent; the tenant having paid down a sum of money to obtain the lease, and the right of alienation; agreeably to the practice of the west of England.

*Life leasehold*, with an uncertain fine, payable to a proprietor, who receives the full rent of the land, at the time of granting the lease, the lessor having a power of alienation, according to the practice of Wales, and some parts of England.

*Leasehold for an ordinary term* (as for less than a hundred years) with the power of alienation.

3154. *Tenure* is the general term for these several holds, or rights of possession. Even the lowest of them gives a sort of temporary property in the land, which is thereby rendered liable to bargain and sale, as property. That species of holding which is given by a lease, without the power of alienation or transfer, being merely the right of occupancy, will be classed among other holdings of a similar nature, in treating of leases and tenancy. (See Book II.)

3155. Legal possession of landed property is gained, by *grant*, as from the crown; by *prescription*, or long usage; by *descent*, as from an ancestor; by *deed of gift*, or settlement; by the *testament* of the deceased owner; by *forfeiture*, as to a mortgagee; by *purchase*, either entered on a court roll, or ratified by a deed of conveyance.

3156. *The title*. Through whatever legal channel possession is obtained, the tradition, record, or deed, that witnesses the fact, gives the title of the possessor; by which he is enabled to hold his lands, and legally to convey them to another. Such is the tenure of lands in England.

## SECT. II. *Of the Kinds and Tenures of landed Property in Scotland.*

3157. *The kinds of landed property in Scotland* are the same as in England, excepting that manorial rights apart from the right to the soil, are unknown.

3158. *The tenure of lands in Scotland* differs very little from the English tenures. All lands are either held *allodially*, that is independently of any superior; or they are held by feudal tenures, by which all lands are considered theoretically as belonging to the crown. The different descriptions of these are termed feu-holding, blanch-holding; burgage, and mortmain. There are also some local tenures, as that of Udal, Lochmaben, &c.

3159. *Feu-holding*. The most ancient feudal tenure in Scotland, was by military service; for all vassals were at first obliged, by the nature of their grant, to serve the superior in war, in such manner, and as often, as his occasions called for it. This species of holding, which was known under the name of *ward-holding*, is now abolished, (by 20 Geo. 3. c. 50.), and requires no farther explanation.

3160. *Blanch-holding*. Where the vassal, in place of feu-duties and personal services, as above described, only pays a small duty to the superior, in full of all demands, and merely as an acknowledgement of his right, whether in money, as a penny Scotch, or in some other article, as a pair of gilt spurs, a pound of wax, &c. it is called blanch-holding. This tenure deviates, more than any other, from the original nature of feus; but next to *feu*, it has now become the most general species of holding.

3161. *Burgage-holding* is a tenure, by which royal burghs hold of the sovereign, the houses and lands that lie within the limits described in their several charters of erection. The proprietor of the burgage lands is liable to pay the municipal taxes; but all the political rights are vested in the magistracy, or town-council of the burgh. It is very limited in its extent.

3162. *Mortmain* is described by Erskine as the tenure by which any feudal subjects are held, which have been granted in donation to churches, monasteries, or other corporations for religious, charitable, or public uses. Strictly speaking, the only lands now held in mortmain, are a few bursaries belonging to the universities, the tenure having been declared superstitious, and the other lands held by it given to the crown. Lands now destined for charitable purposes, are vested in trustees, and held by feu or blanch.

SECT. III. *Of the Kinds and Tenures of Landed Property in Ireland.*

3163. *The kinds of landed property in Ireland* are limited to freehold and leasehold; there are no manorial rights apart from the soil as in England, or feudal rights or holdings as in Scotland.

3164. *The tenure of lands in Ireland* is very simple. It is in general derived from grants made by the crown on the payment of a certain quit rent received by the excise collector of the district. This is the fundamental tenure, and the only other is leases granted by such proprietors; some of these leases are for ever, or on lives, renewable for ever on payment of a certain fine for the insertion of a new life when one drops, or for leases of 999 years, and almost every variety of term with and without lives between that and 21 years. There are no feudal tenures in Ireland; the only abstract right being that of tithes and parochial or other taxes. (See *Wakefield's Account of Ireland.*)

CHAP. II.

*Of the Valuation of Landed Property.*

3165. *When lands are valued with a view to sale or purchase*, the tenure is the first subject of attention. The nature of the tenure often occasions some difficulty in ascertaining its value, but by ascertaining the value of the fee-simple, or freehold tenure, the value of inferior holdings may be found by known rules of calculation, the principal of which we have already noticed (3094).

3166. *The fee-simple value of lands* is liable to fluctuation, by general causes; and is likewise affected, and in much higher degree, by local circumstances. Lands of the selfsame quality are of fivefold value, in one situation, comparatively with what they are worth in another: not merely, though principally, on account of the rental value, or the current price they will let for, to tenants, in different situations; but through other less permanent causes; — as the quantity of land at market, and the number and value of purchasers, in a given district; as well as the temporary spirit which prevails in it, with respect to the possession of landed property, at the period of sale: — circumstances that are worthy of attention, by a purchaser whose views are not confined to any particular spot.

3167. *The usual method of coming at the fee-simple value of land* is, to ascertain its fair rental value, or price by the year, and to multiply this by the number of years' purchase which the existing demand for land will bear, in the given situation, at the time of sale.

3168. *The number of years' purchase*, or the ratio between the rent and the sale value of lands, varies greatly, as from twenty to forty, twenty-five to thirty being the more ordinary numbers. Thus, a parcel of land whose fair rental value is one hundred pounds, is, in common cases, worth from two thousand five hundred to three thousand pounds.

3169. *But the real rental value*, which is the only firm groundwork to proceed upon, whether in the purchase or the management of landed property, cannot easily be obtained. Speaking generally of the lands of England, it is what very few men are able to set down. It is true, that, in every district, and almost every township, there are men who tolerably well know the rate at which the lands of their respective neighborhoods are usually let. But interchange them, reciprocally, into each others districts, and their errors would be egregious, for reasons already suggested. Nor can a mere provincialist, especially in a district which is unenlightened by modern improvements, be aware of the value, even of his own farm, under the best course of management of which it may be capable: nor can he see, through the double veil of ignorance and prejudice, the more permanent improvements that may be made upon it, so evidently as one who has a more general knowledge of rural subjects, and is in the habit of detecting and prosecuting such improvements. Yet it very materially concerns an intended purchaser, in these improving times, to know, before he make his last offer for an estate, whether it is, or is not, capable of being improved beyond its existing value; and what, if any, is the probable amount of improvement: for he is else liable to lose a valuable purchase, through his being out-bidden by a better informed candidate. These facts being evident, it follows, that before an offer be made, especially for a large purchase, it is no more than common prudence, in a man who is not himself a judge, to call in twofold assistance: a provincial valuer, to estimate its fair market price, to the tenants of the neighborhood in which it lies; and a man of more general knowledge, to check

his valuation, and to estimate the improvements of which the lands are evidently capable.

3170. *The leading particulars which affect the value of an estate*, and which require to be considered in its estimation, are quantity, quality, situation, state, outgoings, and abstract rights.

3171. *The quantity of the land* is the groundwork of the estimate; though it has little weight in the scale of valuation. The fee-simple value of an acre of land may be less than twenty shillings, or it may be more than a hundred pounds. Nevertheless, it is on the quantity the rental value is calculated; and it is usual for the seller to exhibit a "particular" of the estate on sale; showing, or which ought to show, not only the aggregate quantity, but the number of acres that each piece or parcel contains; and ought, most particularly, to specify the distinct quantities of the lands of different qualities, in order that their several rental values, may, with greater accuracy and ease, be ascertained.

3172. *The intrinsic quality of the land* is another essential basis of calculation. But even this, in a general view of the value of lands throughout the kingdom, is often of secondary consideration: for, in many cases, their values are given by situation, rather than by soil and substrata. In some cases, as has been already said, the value of the situation may be five-fold that of the intrinsic value of the land. This excessive influence of situation, however, is limited in its effects, and is chiefly confined to the environs of towns, and other extraordinary markets for produce: a great majority of the lands of England owe their values less to situation than to intrinsic quality; and to come at this, with sufficient accuracy, is the most requisite, and, at the same time, the most difficult part of valuation, as it depends almost wholly on extemporary judgment, exercised on the frequently few data which rise to the eye, in passing over the field of estimation. It is almost needless, therefore, to observe, that, to acquire the degree of judgment necessary to this critical task, it is requisite to know the productiveness of lands of different appearances: a species of knowledge which scarcely any thing but mature practice, in the cultivation of lands of different qualities, can sufficiently teach; though long habit may do much, in ordinary cases, towards hitting off the value of lands, without an extensive knowledge of the practice of agriculture. There are, however, cases in which we find both of these qualifications insufficient to give an accuracy of judgment, even among provincial valuers; and a man who ventures to step forward as a universal valuer, should either have an extraordinary talent for his line of profession, or should, after a suitable initiation, have had great experience in rural concerns, in various parts of the kingdom.

3173. *On situation*, the value of lands, aggregately considered, depends less, than on intrinsic quality; though, without doubt, situation has great influence. Thus, an acre of land whose intrinsic quality renders it, in an ordinary situation, worth twenty shillings an acre, would not, in some districts, be worth more than fifteen shillings; while in others it would bear to be estimated at twenty-five shillings, or a higher rent, to a farmer on a large scale, and away from the immediate environs of a town, or any populous district of manufacture; for reasons that will appear in examining the different particulars of situation.

3174. *In the temperature of situation*, whether it is given by elevation, aspect, or exposure, we find a powerful influence, which is capable of altering, exceedingly, the value of lands. The same soil and subsoil, which we not unfrequently see on exposed mountains, and hanging to the north, and which in that situation are not worth more than five shillings an acre, would, if situated in a sheltered vale district, and lying well to the sun, be worth twenty shillings, or a greater rent. Even on climate, something considerable depends. In the south of England, harvest is generally a month earlier than in the northern provinces; though it is not regulated exactly by the climate or latitude of places, a circumstance that requires to be attended to, by those who estimate the value of estates. For an early harvest is not only advantageous in itself, but it gives time to till the ground, or to take an autumnal crop; which are advantages that a late harvest will not so well admit of. And another kind of temperature of situation has still more influence on the value of lands; namely, the moistness of the atmosphere. A moist situation not only gives an uncertain and often a late harvest, but renders it difficult and hazardous, as is too frequently experienced on the western coasts of this island.

3175. *Even in the turn of surface* we find exercise for the judgment. Lands lying with too steep or too flat surfaces, especially retentive arable lands, are of less value than those which are gently shelving, so as to give a sufficient current to surface water, without their being difficult to cultivate. Steep-lying lands are not only troublesome and expensive, under the operations of tillage, but in carrying on manures and getting off the produce. Lands lying with an easy descent, or on a gently billowy surface, may be worth more by many pounds an acre, purchase money, than others of the same intrinsic quality, hanging on a steep.

3176. *A supply of water* is another consideration of some weight, in valuing an estate; for domestic purposes, for the uses of live stock, and for the purpose of irrigation. There are situations in which a copious stream of calcareous water would enhance the fee-simple value of a large estate some thousand pounds.

3177. *A sufficient supply of manure*, whether dung, lime, marl, or other melioration, at a moderate price, and within a moderate distance of land carriage, materially adds to the intrinsic value of lands.

3178. *The established practice of the country* in which an estate lies is capable of enhancing or depressing the value of it exceedingly. Even the single point of practice of ploughing light and loamy lands with two oxen, or two active horses, instead of four heavy ones, is capable of making a difference on good land, which is kept alternately in herbage and corn crops, of five to ten shillings an acre a year; or ten pounds an acre purchase money.

3179. *The price of labor* is another regulator of the marketable price of land in a given district. It is always right, however, to compare this with the habits of exertion and industry which prevail among farm workmen, before the neat amount of labor can be safely set down.

3180. *The price of living*, or expense of housekeeping prevalent among farmers, has its share of influence on the value of lands. In the more reclusive parts of the north of England, farmers and their servants are fed, clothed, and accommodated at nearly half the expense of those of a similar degree, in many parts of the more central and southern provinces. It is not here intended to intimate how husbandmen, their servants and laborers ought to live. As they are the most valuable members of the community, they are well entitled to such enjoyments as are compatible with care and labor. All that is meant, in stating this fact, is to convey a hint to the purchasers of estates. For, in a country where frugality prevails, lands of a given quality will ever bear a higher rent than they will where a more profuse style of living has gained a footing. It is a work of time to change the customs and established manners of a country.

3181. *The spirit of improvement*, or the prejudice against it, which prevails in a district of sale, is a circumstance of some value to a purchaser. For if the former is in a progressive state, especially if it is still in the earlier stages of its progress, a rapid increase of rent may, with a degree of certainty, be expected: whereas, under the leaden influence of the latter, half a century may pass away, before the golden chariot of improvement can be profitably put in motion.

3182. *In markets*, more than in any other circumstance, we are to look for the existing value of lands. Their influence is not confined to towns and populous places of manufacture; for in ports, and on quays, whether of inlets, estuaries, rivers, or canals, markets are met half way: even by good roads their distance from the farm yard may be said to be shortened.

3183. *In this detail of the particulars of situation*, with respect to the value of landed property, we perceive the attentions requisite to be employed, by a valuer who is called upon to act in a country that is new to him. A provincialist, or even a professional valuer, who acts in a district, the existing value of whose lands he is sufficiently acquainted with, determines, at sight and according to the best of his judgment, on their respective values; for he knows, or ought to know, their current prices; what such and such lands let for in that neighborhood; what he and his neighbors give, or would give for lands of the same quality and state, without adverting to the particular circumstances of situation (they being given, in the established current prices which have arisen out of these circumstances); resting his judgment solely on the intrinsic quality and existing state of each field or parcel as it passes under his eye. But let his skill be what it may, in a country in which he has acquired a habit of valuing lands, he will, in a distant district, the current market prices of whose lands may be ten, twenty, or fifty per cent. above or below those which he has been accustomed to put upon lands of the same intrinsic qualities and existing states, find himself at a loss, until he has learnt the current prices of the country, or has well weighed the circumstances of situation; to which, in every case, he must necessarily attend, before he can determine their value under an improved practice, or venture to lay down general rules for their improvement.

3184. *The existing state of lands*, or the manner in which they lie, at the time of sale, is the next class of circumstances which influence their marketable value.

3185. *Their state with respect to enclosure* is a matter of great consideration. Open lands, though wholly appropriated, and lying well together, are of much less value, except for a sheep walk or a rabbit warren, than the same land would be in a state of suitable enclosure. If they are disjointed and intermixt in a state of common field, or common meadow, their value may be reduced one third. If the common fields or meadows are what is termed Lammas land, and become common as soon as the crops are off, the depression of value may be set down at one half of what they would be worth, in well-fenced enclosures, and unencumbered with that ancient custom. Again, the difference in value between lands which lie in a detached state, and those of the same quality that lie in a compact form, is considerable. The disadvantages of a scattered estate are similar to those of a scattered farm. Even the single point of a want of convenient access to detached fields and parcels is, on a farm, a serious evil. And it is on the value of farms that the value of an estate is to be calculated.

3186. *The state of the roads*, whether public or private, within an estate, and from it to the neighboring markets, or places of delivery of produce, is an object of consideration to a purchaser.

3187. *The state of the watercourses*, or shores and ditches, within and below an estate, requires to be examined into; as the expense of improvement or reparation will be more or less, according to their existing state, at the time of purchase; or, perhaps, by reason of natural causes, or through the obstinacy of a neighbor, and the defectiveness of the present laws of the country in this respect, the requisite improvement cannot be effected at any expense.

3188. *The state of drainage* of lands that lie out of the way of floods or collected water, requires to be taken into consideration. For although the art of draining is now pretty well understood, it cannot be practised, on a large scale, without much cost.

3189. *The state of the lands, as to tillage and manure*, is entitled to more regard than is generally paid to it, in valuing them. But even to a purchaser, and still more to a tenant for a term, their state, in these respects, demands a share of attention. Lands, that are in a high state of tillage and condition, so as to be able to throw out a succession of full crops, may be worth five pounds of purchase money an acre, more than those of the same properties, which are exhausted by repeated crops, and lie in a useless state of foulness: from which they cannot be raised, but at a great expense of manure and tillage.

3190. *The state, as to grass or arable*, is better understood, and generally more attended to. Lands in a state of profitable herbage, and which have lain long in that state, are not only valuable as bearing a high rent, while they remain in that state, but after the herbage has begun to decline, will seldom fail to throw out a valuable succession of corn crops. Hence, the length of time which lands, under valuation, have lain in a state of herbage, especially if it has been kept in a state of pasturage, is a matter of enquiry and estimation.

3191. *Lastly, the state of farm buildings and fences* is a thing of serious consideration. Buildings, yards, and enclosures that are much let down, and gone to decay for want of timely reparation, incur a very great expense to raise them again to their proper state. And, when great accuracy of valuation is called for, as when the purchase value of an estate is left to reference, and when the tenants are not bound, or if bound are not able to put them in the required state, it becomes requisite to estimate the expense which each farm, in that predicament, will require to put it in sufficient repair, so as to bring the

whole into a suitable state of occupation. And the same principle of valuation holds good in ordinary purchases.

3192. *Deductions, encumbrances, and outgoing*s are leases, tithes, taxes, fixed payments, repairs, and risks.

3193. *Leases*. In considering the nature of leasehold tenures, it appears that, by a long lease, the fee-simple value of an estate may be, in effect, annihilated. Even a lease for lives, with a mere conventional rent, may reduce it to nearly one third of its fee-simple value. And every other kind of lease, if the rent payable be not equal to the fair rental value at the time of sale, is an encumbrance; even to a purchaser who has no other object in view than that of securing his property on land, and receiving interest, in rent, for the money laid out. If personal convenience be immediately wanted, or improvements required to be done, a lease, though the tenant pay a full rent, becomes an obstacle to the purchase.

3194. *Tithes*. If in valuing lands they are considered as tithe free, the tithe, or modus, if any, requires to be deducted as an encumbrance; and seeing the great variation in the values of tithes and moduses, according to customs and plans of occupation, it is the plainest way of proceeding to value all lands, as free of tithe, and afterward to make an allowance for whatever they may be estimated to be worth: an allowance which, in some cases, as on corn-land estates, forms a considerable portion of the fee-simple value of the lands; while on grass-land estates, especially such as are pastured by cattle, this encumbrance, so galling to the corn-grower, is in great part avoided.

3195. *Taxes*. Although it may be called the custom of England for proprietors to pay the *land tax*, and the occupier all other taxes, yet this is not the universal practice. Nor is it, in valuing an estate on sale, and to be let at will, a matter to be enquired into. The annual amount of the payable taxes and other outgoing is the fact to be ascertained. For whosoever discharges them, they come as a burthen upon the gross value of the lands, out of which they are payable; for if a tenant pay them, his rent is, or ought to be, estimated and fixed accordingly. If, however, an estate, on sale, is already let under lease for a term to come, it is highly requisite to ascertain what parts of the annual outgoing and repairs are discharged by the tenants, and what the proprietor will be liable to, during the term to run. The land tax, where it still exists, is extremely uncertain as to its value, and the poor tax is equally varying in different situations. The church, highways, and county rates are, taking them on a par of years, less liable to local uncertainty, and are consequently less entitled to enquiry, by a valuer.

3196. *Fixed payments, or rent charges*, such as chief rents, quit rents, annuities, endowments, schoolmasters' salaries, charitable donations, &c. to which an estate is liable; also

3197. *Repairs of public works, buildings, roads, &c.* incumbent on the estate on sale, are subjects of inquiry and estimation; as well as the ordinary repairs above noticed. And moreover,

3198. *The hazard or risk*, which naturally, or fortuitously, attends the lands under valuation; as that of their being liable to be inundated in summer, or to be torn away by floods, at any season; is entitled to mature consideration. For although these evils may generally be remedied, by river breaks and embankments, the erecting of these is mostly attended with great expense; and the estimated value of this becomes, in course, a fair deduction.

3199. *Appurtenant to an expensive estate, there are generally other valuable considerations*, besides the purchase value of the lands. These are,

3200. *Minerals and fossils*, whether metals, fuels, calcareosities, or grosser earths.

3201. *Waters*, whether they are valuable for fisheries, decoys, mills, domestic purposes, or the irrigation of lands.

3202. *Timber*, of woods and hedgerows.

3203. *Buildings* that are not let with the farms; but which bear rent, independent of the lands; yet which, when scattered over an estate, may well be considered as belonging to landed property.

3204. *The estimated value of evident improvements*.

3205. *The abstract rights* which arise out of appropriated lands, or their appurtenances; as

3206. *The right of commonage*, which is generally of some value, even when commons lie open, and may be of more, when they shall be enclosed; provided the cost of enclosure do not turn out to be more than the extra value of the appropriated lands, above that of the common right in their open state.

3207. *The right of seigniority* to fee-farm rents, or other chief rents, payable to the possessor of the lands on sale, out of the lands of other proprietors. These rents, though small, are of certain value in themselves; and the idea of superiority which they convey to some men's minds, may be worth more than the pecuniary value; which, indeed, where the sums are very small, (as is often the case) is much lowered by the expense of collecting them: beside the trouble, vexation, private quarrels, and lawsuits they are liable to excite, when, through neglect, they are half forgotten, and the vassal is willing to catch at the circumstance, to try to get rid of the teasing and humiliating encumbrance. This, however, may serve to account for their having been handed down with reverential care, through a succession of ages; until, in many instances, even their origin, and much more the circumstances attending it, are difficult or

impossible to trace. But, surely, a man of a liberal turn of mind, who has no interest in legal contests, and who prefers solid gold to a trinket, would not hesitate to collect these scattered wrecks of property, and to convert them to a more civilized, rational, and profitable purpose. On the other hand, any man of an independent spirit would pay more than a fair price, would pay liberally, to be exonerated from so base a burden. If, however, a vassal's chains sit easy upon him, let him wear them. What is here meant to be intimated is, that he ought to have, in liberality, if not in law, a fair opportunity of throwing them off.

3208. *The rights of feudality*, or manorial rights, are, at present, if not in their origin, very different from those last mentioned. In the day of their establishment, they appear to have been founded in wisdom and a degree of political necessity; and, by the correcting hand of time, they arrived at a high degree of political perfection. The simple and easy mode of transferring property, which the feudal system established, was well adapted to the illiterate age in which it had its rise. Even in these lettered days, and among the ruins of feudal rights, the copy of a court-roll is considered as the clearest title a man can have to his possession! what a hint is this to modern legislators! The value of feudal rights is to be estimated by the quit rents, fines, heriots, escheats, and amerciaments, which long custom and a train of circumstances have attached to the given court. And beside what relates to the appropriated lands of the manor, the lord has a profit arising from the commonable lands (if any lie within it) as lord of the soil; which cannot be broken without his permission. Hence the fossils and minerals, which it covers, belong to him; as well as the timber which grows upon the waste, and the waters that are annexed to it. He is moreover, in ordinary cases, lord of the game which inhabits or strays upon this manor. This, however, being a right of pleasure, rather than of profit, has no fixed standard of estimation.

3209. *The right of tithes*, when attached to an estate, is the most desirable of abstract rights, arising out of landed property. For, as far as the right extends, (whether to a lay rectory, or a vicarial impropriatorship) the lands which it covers become, in effect, tithe free; as every judicious proprietor incorporates the rents of the tithe with those of the lands out of which it is payable: thus (if the right, as it generally is, be rectorial) freeing them wholly from the encumbrance of tithes, as a tax on improvements, and as an obstacle to the growth of corn. The value of tithes, as has been intimated, is so various, that nothing but local information can enable a valuer to estimate them with sufficient truth.

3210. *The right of advowson*, or the privilege of appointing a pastor, to propagate religion and morality upon an estate, properly enough belongs to its possessor; as no other individual is so intimately concerned in the moral conduct of its inhabitants.

3211. *The right of representation or election*, or the appointment (in whole or in part) of a legislator, to assist in promoting good order, in the nation at large, equally belongs to the owner of territorial surface.

---

### CHAP. III.

#### *Of the Purchase or Transfer of Landed Property.*

3212. *In bargaining for an estate* there are two methods in use; the one by public biddings, and the other by private treaty. In either a certain degree of caution is requisite; and in both an accurate valuation is the best safeguard.

3213. Among the *preliminaries of purchase, by private contract*, the particulars which may be required to be furnished by a seller, are first to be enumerated. These are; the quantities of the several pieces of the lands on sale, together with the maps, or rough drafts, of the same: the tenure under which they are holden: some assurance as to the title of the seller, and his right of alienation: the tenancy under which the several farms are let; and, if on lives, the ages of the nominees; if for a term of years, the number unexpired; if at will, the notices (if any) which the tenants have had.

3214. *An abstract of the covenants under which they are let*; particularly on those which relate to taxes and repairs, to the expenditure of produce, to the ploughing of grass lands, &c.

3215. *The existing rents and profits receivable*; whether for tenanted lands, appurtenances, or abstract rights; with the estimated value of the demesne, and the wood lands in hand; together with the estimated value of the timber growing upon the estate on sale, as well as of the minerals and fossils which it may contain: the outgoings to which the estate is liable: the proposed time of the delivery of possession: the price and the mode of payment expected.

3216. *The particulars of instructions to be given to a surveyor*, or other valuer, of an estate to be purchased, may next be particularized; it will be right, however, to premise, that much, in this respect, depends on the probability of purchasing, and on the time allowed for making the estimate.

3217. *In cases of sale by public auction*, where there can be no certainty as to purchase, and where the time for valuation is limited, a rough estimate of each farm, and a general idea of the value of the timber and other appurtenances, may be all that can be prudently ascertained.

3218. But, *in a sale by private contract*, where the refusal of an estate is granted, and time allowed for deliberate survey, a more minute investigation may be proper, especially when there is every reason to believe that a bargain will take place. For the same report will not only serve as a guide to the purchase, but will become a valuable foundation on



which to ground the future management of the estate. For these, and other reasons, a purchase by private contract is most to be desired, by a gentleman who is not in the habit of personally attending public sales, and is unacquainted with the business of auction rooms.

3219. *The particulars to be required from a surveyor, or surveyors, are principally these: the rental value of each field or parcel of land, with the state in which it lies, as to arable, meadow, pasture, or woodland: the value of the timber and other appurtenances: the characteristic, and the state of management of each farm or tenement, with the eligibility of its occupier, together with the state of repair of buildings, gates, fences, watercourses, and roads: the amount of the encumbrances and outgoings: and, lastly, the probable value of the improvements of which the estate may appear to be capable; whether by ordinary or extraordinary means.*

3220. *The subjects of treaty after these particulars of information are procured are few. The two statements have been duly compared, so that no misunderstanding can take place between the parties, the price, with the times and mode of payment, are the principal matters of agreement. A clear understanding respecting the custody of title deeds, and the expenses of conveyance, require, however, to be enumerated among the preliminaries of purchase.*

3221. *The business of negotiation is best carried on by letters, which become vouchers of facts. Whatever is done by interview, requires to be reduced to writing, and to be read by, or to, the parties, before they separate, that no possibility of misconception may arise. And, added to these precautions, it is proper, in large purchases, and when abstracts of intricate title deeds are to be made out, and examined, that a legal contract, or memorandum of agreement, should be entered into, for the mutual satisfaction and surety of the parties.*

3222. *This contract, and the deed of conveyance, (namely the instrument which is legally to transfer the property from the seller to the purchaser,) may be said to conclude and ratify the business of purchase; and in this part of it legal assistance is essentially necessary, to examine existing deeds, and see that the seller has a legal right and clear title to the land, and a legal power to dispose of it, as well as to draw up, or examine, the fresh deed of conveyance, and see that it is sufficient to transfer the property, legally and adequately, to the purchaser.*

3223. *The preservation of titles may be adverted to before dismissing this subject. In Scotland, deeds of conveyance, and other deeds, are registered in one magnificent building, whose internal economy is as admirably adapted to its design, as its outward form is beautiful. And, in England, there are two counties (Yorkshire and Middlesex) which are termed register counties; in which abstracts of deeds are preserved, and so arranged as to be readily referred to. Hence, in cases where the original deeds are destroyed, or lost, these registered abstracts are sufficient evidences of their having existed, and capable of securing the titles of estates to their rightful owners; and are moreover valuable, in preventing fraudulent practices, particularly respecting mortgages. Nevertheless, the other counties of England remain, from reign to reign, destitute of these advantages.*

---

## BOOK II.

### OF THE LAYING OUT, OR GENERAL ARRANGEMENT OF LANDED ESTATES.

3224. *The laying out of an extensive landed estate embraces a variety of subjects, and requires extensive information and enlarged views of political, agricultural, and even of moral improvement. In new countries, such as America, where an estate is laid out *ab origine*, this is more particularly the case; but the observation will also apply to many parts of the British isles, where estates, long since appropriated, require re-arrangement and improvement.*

3225. *Among the different objects of attention in laying out or re-arranging a landed estate, one of the first is its consolidation, or the rounding off or simplifying the outline so as the whole may be brought into a compact form. This *envis de s'arrondir* seems to have existed, and the proximity and intermixture of property to have been felt as an evil by landed proprietors in all ages. Ahab desired the field of Naboth, because it was near to his house; and Marvel, the attorney (*Massinger's New Way to Pay Old Debts, &c.*) advised his client to "hedge in the manor of Master Frugal," because "his land, lying in the midst of yours, is a foul blemish."*

3226. *In consolidating property in Britain, an equally desirable object is the appropriation of commonable lands, which, in England, can only be effected under the autho-*

city of a special act of the legislature; but is accomplished with less difficulty in Scotland, and is rarely necessary in Ireland.

3227. *The arrangement of the interior of an estate* naturally follows the determination of the ring-fence, and the complete possession of all that is within. Here the first thing will probably be to determine the demesne lands, or site of the proprietor's residence, and the extent of territory he means to attach to it and retain in his own occupation. Then follows the intersection of the estate with roads, and probably a canal; the choice or determination of the sites for towns, villages, manufactories, and mines, mineral quarries, or fisheries, if such exist naturally. Lastly, the grounds to be planted being determined on, the remaining part of the property will consist of the lands to be let out for cultivation by farmers, or other tenants of the soil. In conformity with this view of the subject, we shall consider, in succession, the consolidating of estates, the appropriating of commonable lands, the choice of demesne, road-making, canal-making, the establishment of villages and manufactories, the working of mines and quarries, the establishment of fisheries, the formation of plantations, the planting of orchards, and the laying out of farms and farm-lands.

## CHAP. I.

### *Of consolidating Detached Property.*

3228. *The advantages of a compact estate* over one whose lands lie scattered and intermixed with other men's properties, are evident. The management, whether of detached farms, as part of an estate, or scattered fields, as parts of a farm, is conducted with inconvenience; beside the unpleasant alterations to which intermixed lands are liable to give rise. The different methods of compressing landed property into the required state, are by exchange, by purchase, and by sale.

3229. *Where the lands of two proprietors lie intermixed with each other*, an amicable exchange is the most eligible. And were it not for the childish piques and petty jealousies which so frequently take root between neighboring proprietors (and are cherished perhaps by their officious friends), lands of this description could not long exist; the evil, in almost any case, being easily removed. Each party having chosen one, or, in extensive concerns, two referees; and the two or four so chosen, having named a third or fifth, the required commission is formed; and bonds of arbitration being signed, the commissioners proceed, as under an act of appropriation of commonable lands, to assign each proprietor his rightful share, in the most profitable situation which the given circumstances will permit. This mode of proceeding might be adopted by the most distant parties, or the most inveterate enemies; and, doubtless, with advantage to the property and peace of mind of each.

3230. *Where an estate or a farm is disjointed*, by the intermediate lands of others, it is not only pleasurable to be possessed of them, but profitable to purchase them, even at a higher price than they are intrinsically worth; consequently at much more than their value, as detached lands, to their proprietor. Yet such is often the waywardness and ill-judged policy of the holders of lands so situated, that they will rather continue to hold them with disadvantage, than sell them at a fair price. An equitable way of determining a matter of this sort is to ascertain the value of the lands to the holder, as detached lands, and likewise their value to the candidate, as intermixed lands; and to let the mean between the two values be the selling price. By this method, both parties become actual and equal gainers. If the possessor of such lands should lie in wait for an exorbitant offer, the most efficient mode of proceeding is to offer a high number of years' purchase on their fair rental value, indifferently considered, in the situation in which they lie, and to propose to settle such rental value by arbitration. This is a sort of offer which every honest man can readily understand; and if the holder has any character to lose in his neighborhood, he cannot refuse it; if he has not, a calculation of the difference between the rent he is receiving and the interest of the money offered, consequently of the annual loss which he is sustaining by not accepting the offer, will, sooner or later, bring him to a sense, if not of his duty as a member of society, of his own interest.

3231. It is, in general, right management to dispose of the detached parts of an estate, and to add to the main body. The whole is then more easily superintended, and managed at less expense; while small properties, if suitable steps be taken, and proper seasons of disposal caught, will generally fetch more than larger parcels, of equal rental value, timely and judiciously purchased.

3232. *In selling, as in purchasing estates, two methods present themselves.* They may be sold by auction or by private contract. To raise a sum of money expeditiously, the

former may be the most eligible; though attended with more expense and more notoriety than the latter; which, for the purpose under view, and when expedition is not necessary, will generally, if properly conducted, be found preferable. To conduct a sale of detached lands with judgment and reputation, the first step is to have them deliberately valued by at least two men of character and ability, and to divide them into parcels or lots, according to situation, and so as to render them of superior value to adjacent proprietors. Then fix upon each parcel such value as it is fairly worth to the owner of the lands with which it is naturally united; and give him the refusal of it. Such parcels as are not disposed of in this way, may either lie open to private contract, or be sold by public auction; the motive for selling being, in either and every case, openly declared. It is to be remarked, however, that for a sale by auction, a fresh arrangement of lots will be required: the principle of allotment being in this case the reverse of the former. At an auction, a certain degree of competition is requisite to raise the article on sale to its full value; and it is no more than common prudence in the seller to make up his lots in such a manner as will bring together the greatest number of competitors.

## CHAP. II.

### *Of appropriating Commonable Lands.*

3233. *Commonable lands*, or such as lie intermixed or are occupied in common by the inhabitants according to certain laws and customs, may be considered in regard to their *origin and kinds*, and their appropriation or *division*.

#### SECT. I. *Of the Origin and different Kinds of Commonable Lands.*

3234. *A very few centuries ago, nearly the whole of the lands of Britain lay in an open, and more or less in a commonable state.* (See Fitzherbert on the Statute Extenta Manerii.) Each parish, or township, (at least in the more central and northern districts) comprised different descriptions of lands; having been subjected, during successive ages, to specified modes of occupancy, under ancient and strict regulations, which time had converted to law. These parochial arrangements, however, varied somewhat in different districts; but, in the more central and greater part of the kingdom, not widely; and the following statement may serve to convey a general idea of the whole of what may be termed common-field townships, throughout England.

3235. *Each parish or township was considered as one common farm; though the tenantry were numerous.* (See also Blackstone's Commentaries, art. *Tithing of Townsh.*) Round the village in which the tenants resided, lay a few small enclosures, or grass yards, for rearing calves, and as baiting and nursery grounds, for other farm stock. This was the common farmstead, or homestall, which was generally placed as near the centre of the more culturable lands of the parish or township as water and shelter would permit.

3236. *Round the homestall lay a suit of arable fields*, including the deepest and soundest of the lower grounds, situated out of water's way, for raising corn and pulse; as well as to produce fodder and litter for cattle and horses, in the winter season; and, in the lowest situation, as in the water-formed base of a rivered valley, or in swampy dips, shooting up among the arable lands, lay an extent of meadow grounds, or ings, to afford a supply of hay, for cows and working stock, in the winter and spring months.

3237. *On the outskirts of the arable lands*, where the soil is adapted to the pasturage of cattle, or on the springy slope of hills, less adapted to cultivation, or in the fenny bases of valleys, which were too wet, or gravelly lands, thrown up by water, which were too dry to produce an annual supply of hay with sufficient certainty, one or more stunted pastures, or hams, were laid out for milking cows, working cattle, or other stock which required superior pasturage, in summer.

3238. *The bleakest, worst-soiled, and most distant lands of the township*, were left in their native wild state, for timber and fuel, and for a common pasture, or suit of pastures, for the more ordinary stock of the township, whether horses, rearing cattle, sheep, or swine; without any other stint, or restriction, than what the arable and meadow lands indirectly gave, every joint-tenant, or occupier of the township, having the nominal privilege of keeping as much live stock on these common pastures, in summer, as the appropriated lands he occupied would maintain in winter.

3239. *The appropriated lands of each township* were laid out with equal good sense and propriety. That each occupier might have his proportionate share of lands of different qualities, and lying in different situations, the arable lands, more particularly, were divided into numerous parcels of sizes, doubtless, according to the size of the given township, and the number and rank of the occupiers.

3240. *The whole was subjected to the same plan of management*, and conducted as one common farm, for which purpose the arable lands were divided into compartments,

or "fields," of nearly equal size, and generally three in number, to receive, in constant rotation, the triennial succession of fallow, wheat (or rye), and spring crops (as barley, oats, beans, and peas): thus adopting and promoting a system of husbandry, which, howsoever improper it is become, in these more enlightened days, was well adapted to the state of ignorance, and vassalage, of feudal times; when each parish or township had its sole proprietor; the occupiers being at once his tenants and his soldiers, or meaner vassals. The lands were in course liable to be more or less deserted by their occupiers, and left to the feebleness of the young, the aged, and the weaker sex. But the whole township being, in this manner, thrown into one system, the care and management of the live stock at least, would be easier and better than they would have been under any other arrangement. And, at all times, the manager of the estate was better enabled to detect bad husbandry, and enforce that which was more profitable to the tenants and the estate, by having the whole spread under the eye at once, than he would have been, had the lands been distributed in detached unenclosed farmlets; besides avoiding the expense of enclosure. And another advantage arose from this more social arrangement, in barbarous times: the tenants, by being concentrated in villages, were not only best situated to defend each other from predatory attacks; but were called out, by their lord, with greater readiness, in cases of emergency. Therefore, absurd as the common-field system is, in almost every particular, at this day, it was admirably suited to the circumstances of the times in which it originated; the plan having been conceived in wisdom, and executed with extraordinary accuracy, as appears in numberless instances, even at this distance of time.

3241. *Uninhabited tracts or forests.* In different parts of Britain there were and still are extensive tracts of land, some of them of a valuable quality, which lie nearly in a state of wild nature, which were never inhabited, unless by freebooters and homebred savages. These uninhabited tracts are styled forests; and heretofore, many or most of them have been attached to the crown; and some of them are still under royal patronage. Whether they were originally set out for royal pastime, merely, or whether the timber which stood on them was of peculiar value, or whether, at the time of laying out townships, those tracts were impenetrable woods, inhabited by wild beasts, and, when these were destroyed, or sufficiently overcome to render them objects of diversion, were taken under the protection of the crown, is not, perhaps, well ascertained. There were also tracts of that description in different parts of England, but which appear, evidently, to have been enclosed from a state of woodland or common pasture; though it is possible they may have been nominally attached to neighboring parishes. Of this description, principally, are the Wealds of Kent and Sussex, and many other old enclosed lands, in different parts of the kingdom, whose fields or enclosures are of irregular shapes, and their fences crooked. These woodland districts are like the forest lands, divided into manors, which have not an intimate connexion or correspondence with parishes or townships: a further evidence, that they were in a wild state, when the feudal organization took place.

3242. *In the western extreme of the island, the common-field system has never, perhaps, been adopted;* has certainly never been prevalent, as in the more central parts of England. There, a very different usage would seem to have been early established, and to have continued to the present time, when lords of manors have the privilege of letting off the lands of common pastures, to be broken up for corn; the tenant being restricted to two crops; after which the land is thrown open again to pasturage. And it is at least probable, that the lands of that country have been cleared from wood, and brought into a state of cultivation, through similar means. At present, they are judiciously laid out, in farms of different sizes, with square straight lined enclosures, and with detached farmsteads, situated within their areas; the villages being generally small and mean; the mere residences of laborers. Circumstances these are, which strongly evince that the common field system never took place, in this part of the island, as it did in the more central parts of England. Ireland, also, has been enclosed (though not fenced) from time immemorial.

3243. *The feudal organization having lost its original basis,* has itself been mouldering away, more particularly during the last century. A great majority of the appropriated common-field lands and commons have been partially, or wholly enclosed; either by *piecemeal*, each proprietor enclosing his own slip, a very inconvenient mode of enclosure, or by *general consent*, the whole of the proprietors agreeing to commit their lands to the care and judgment of arbiters, or commissioners, who, restoring the fields to their original intirety, reparcelled them out, in a manner more convenient to the several proprietors, and laid each man's portion, which had consisted of numberless narrow slips, in one or more well shaped grounds.

3244. *In England* this requires to be effected by a separate act of parliament for each enclosure. In these acts commissioners are named, or directed to be chosen by the proprietors, who, according to certain instructions in the act or law, and the general principles of equity, divide the township among all who have an interest in it. It appears by the statute books, that from the year 1774 to the year 1813, no fewer than two thousand six hundred and thirty-two acts of enclosure have been passed; the average in the first twenty years being thirty-seven, and in the last twenty years ninety-four.

3245. *In Scotland* a general bill of enclosure was passed by the parliament in 1695, and in consequence of it the whole country has for nearly a century past been in distinct possessions. In Ireland, as we have already remarked, no enclosure act became necessary, and the country is considered as suffering from the long continued minute division of landed property.

3246. *As a contrast to the general eagerness for enclosing*, it may be useful to present the moderate, and in our opinion, judicious observations of Loch, to whom it appears very doubtful how far the indiscriminate enclosure of commons, arising out of the high nominal prices of grain, has been in every instance of advantage to the nation. Many of them, he says, certainly, could never pay the expense of obtaining the act, — of the commissioners' fees, — of the construction of the fences, — and of bringing the land into cultivation. In this respect there has been a dead loss of capital to the country. It is conceived that it is not carrying this feeling too far, to regret the destruction of some of those beautiful and picturesque forests and chases which once surrounded London, and to hope that this may go no further. It may even be permitted, perhaps, to include within this regret as a national loss, the destruction of Windsor forest, the most appropriate accompaniment of the noblest royal residence in Europe. The preservation of some of these chases is as essential to the poorer classes of the metropolis as to the rich. To the former they afford health, exercise, and amusement; in the latter they produce and cherish that love of the country, and of rural sports, so important in a constitutional point of view. They nourish that feeling for and knowledge of the beauties of nature, (freed from the love of gain as connected with the productions of the soil,) which enlarge our understandings, and exalt every better sentiment of the heart, encouraging the practice of the social virtues, and checking those more selfish habits, which the general distribution of great wealth is too apt to engender. There cannot be a doubt that not only for these reasons would the abstaining from some of these enclosures have been beneficial, but, in an economical point of view, it would have been most advantageous to the nation. In how many ways could not the capital, thus lost, have been beneficially applied, both for the individual and the country! How much a richer man would the land-owner have been, if he had saved much of this expense, and permitted a more liberal importation of foreign corn! How much better would it have been for the country! In this, as in every other instance, it might be demonstrated, that that which would have been best for one, would have been so for all, and that the same system must always benefit equally the English landlord, tenant, merchant, manufacturer, and artisan.

## SECT. II. *Of the general Principles of appropriating and dividing Commonable Lands.*

3247. *There are few lands in Britain unappropriated, excepting in England*, and these may be classed as forest lands, and other extensive wastes, on which several manors, or adjacent townships, have a right of common pasturage; commonable lands of distinct townships or manors, whose appropriated lands are wholly enclosed, and in a state of mixed cultivation; commonable lands of townships, whose arable fields, &c. are partially enclosed; and commonable lands of townships, whose arable fields remain wholly open.

3248. *The principles on which the appropriation of those lands requires to be conducted*, are thus laid down by Marshal. By an established principle of the general law, or constitution of the country, immemorial custom establishes right. Hence the original rights and regulations respecting the lands under view, are not now the proper subjects of investigation; nor are the changes that may have taken place during a succession of centuries, from the origin of forests and townships, to the latest time which is no longer within memory, objects of enquiry; but solely, the acquired rights which exist in a given case at the time of appropriation, and which would continue to exist were it not to take place. The possessor of a cottage which has enjoyed, time immemorial and without interruption, the liberty of pasturage, though such cottage were originally an encroachment of a freebooter, or an outlaw, has indisputably as legal a claim to a proportionate share of the commonable lands, as the possessor of the demesne lands of the manor has, merely as such, although they may have descended from father to son, from the time of their severalty; for it is evidently on the estimated values of the respective rights which exist, and which can be rightfully exercised *in time to come*, and on these alone, that a just and equitable distribution can be effected.

3249. *But before the distribution of commonable lands among the owners of common pasturage can take place*, the more abstract rights which belong to commons require to be estimated, and the just claims of their possessors to be satisfied. These are principally manorial rights, and the rights of tithes.

3250. *Manorial claims* are to be regulated by the particular advantages which the lord of a given manor enjoys, and which he will continue to enjoy while the commons remain open and unappropriated; whether they arise from mines, quarries, water, timber, alien tenants, fuel, estover, pannage, or game. His claim as guardian of the soil that is productive of pasturage only, is in most cases merely honorary; and it remains with parliament to fix the proportional share of the lands to be appropriated, which he shall be entitled to as an equivalent for such honorary claim.

3251. *But in the case of thriving timber standing on the property*, the claim of the lord of the manor in right of the soil is more substantial; for out of this he has in effect a real yearly income, equal to the annually increasing value of the timber; a species of advantage which, if the commons remain open and unappropriated, he will in course continue to enjoy so long as the timber continues to increase in value. His claim, therefore, in this respect, depends on the quantity of timber, and its state of growth taken jointly. Young thriving timber not only affords an annual increase of value at present, but will continue its benefits for many years to come, if it be suffered to remain undisturbed on the soil; and its owner, doubtless, has a prospective claim on the soil which supports it during the estimated period of its future increase; whereas dotards and stunted trees which afford no

increase of value, do not entitle their owner to any share of the soil they stand upon. The trees themselves, or their intrinsic value, appears to be all that the lord has a right to claim.

3252. *The claims of tithe owners*, aggregately considered, are more complex and obscure. In cases where the great and small tithes are united, and in which the tithe of wool and lamb, and that of grain, roots, and herbage belong to the same owner, it may seem to be reasonable that he should have the option of receiving land of equal value to the existing value of the tithes, or of taking the chance of their value, in the state of cultivation. But seeing the evil tendency of corn tithes, and the impropriety of laying on so harmful a burden, as they are now become, upon lands that have never borne it, there can be little risk in saying that it would be at least politic in parliament to prevent it. Besides, it stands part of the statute law, that lands which have never been under tillage, shall not pay tithes during the first seven years of their cultivation; during which time the incumbent's income might, by leaving the tithe to take its course, be materially abridged, and his circumstances thereby be rendered distressful. On the whole, therefore, it appears to be proper in this case, that the law to be enacted should instruct commissioners to set out lands equal to the existing value of the tithes at the time of appropriation, and where much corn land shall be appropriated, to set out a further quantity equal to the estimated reversion of their extra value, (if any arise in the estimate,) seven years after the appropriation shall have taken place.

3253. *Again, in cases in which the tithe of lamb and wool, and the tithe of corn, &c. belong to separate owners*, the line of rectitude and strict justice to all parties appears to be still more difficult to draw. The former is clearly entitled to land, or a money payment equal to his loss of tithe. But the right of the latter is less obvious. To cut him off entirely from any share of the lands, and likewise from any share of tithes to arise from them after they shall be appropriated, may seem unjust; he may be a lay rector, and may have lately purchased the tithes, or a clerical rector who has recently bought the advowson, under the expectation of an enclosure. On the other hand it appears to be hard, that the proprietors of the parish should first give up land for the tithe of wool and lamb which will no longer exist, and then be liable to a corn tithe on the same lands, after they shall have bestowed on them great expense in clearing and cultivation. Indeed, the injustice of such a measure is evident. A middle way, therefore, requires to be sought. And it will be difficult, perhaps, to find one which has more justice in it than that which is proposed for the first case. Thus, after the value of the lamb and wool tithe, &c. has been ascertained, and land set out as a satisfaction for it, estimate the value of the corn tithe, &c. seven years after the time of appropriation; and set out a further quantity for the reversion of the extra value (if any) of the latter over the former, and in this manner free the lands entirely from this obstacle to their improvement.

3254. *If any other abstract claim*, on the lands to be appropriated, be fairly made out, or any alien right (as that of a non-parishoner, or extra-manorial occupier, who has acquired, by ancient grant, or by prescription, the privilege of depasturing them) be fully proved, its value requires to be accurately estimated, and land to be assigned in lieu of it.

3255. *The remainder of the unstinted commons* of a given township or manor belong to the owners of its commonright lands and houses. But in what proportion may be difficult to determine with mathematical precision. Nevertheless, by adhering strictly to the general principle, on which alone an equitable appropriation can be conducted, — namely, that of determining each man's share by the benefit which he has a right to receive at the time of appropriation, and which he might continue to receive, were it not to take place, — truth and justice may be sufficiently approached.

3256. One of the first steps, toward an equitable distribution of unstinted commons, is to ascertain the commonright houses, and to distinguish them from those which have no right of commonage; and which, therefore, can have no claim to any share of the lands of the unstinted commons, further than in the right of the lands they stand upon. By an ancient and pretty generally received, though somewhat vague, idea respecting the rights of commonage, the occupier of every commonright house has the privilege of depasturing as many cattle, sheep, or other live-stock, on the common in summer (provided that it must be understood that it is large enough to permit every occupier to exercise this right), as the grounds he occupies within the township or manor can properly maintain in winter; and no one can exceed that proportion; for the surplus of the pasturage, if any, belongs to the lord of the soil. (See Fitzherbert and Blackstone.)

3257. Under this regulation, *the appropriated lands of a common field township*, which are not occupied jointly with a commonright house, may be said to be deprived, during the time they are so occupied, of their right of commonage; and in some of the private bills of enclosure, which have been suffered to pass through parliament, the lands which happened to be in this state of occupancy, at the time of passing the bills, were deprived of their interest in the common lands, for ever; notwithstanding, perhaps, they had a

few years preceding this accidental circumstance an undoubted right to their portion of them; a right which, a few weeks or a few days afterward, might have reverted to them, without the smallest taint, by the temporary alienation. If any of the appropriated lands of a township or manor have been estranged from its commons, during time immemorial; have never been occupied jointly with a commonright house, or in any way enjoyed, of right, the common pasturage within memory; they may with some reason be said to have lost their right, and be excluded from a participation.

3258. By this ancient and in a degree essential usage, *commonright houses have a clear right to the lands of the commons*, superior to that of the ground they stand upon; especially if they rightfully enjoy a privilege of partaking of the fuel and pannage (as acorns, masts, &c.) they afford; for these properly belong to the houses, not to the lands; and still more especially, if they are conveniently situated for enjoying the several benefits which the commons afford in their wild state. And whatever a commonright house is worth, merely as such, that is to say whatever it will let or sell for, over and above a non-commonright house of the same intrinsic value, it certainly ought to participate in the distribution, according to such extra value.

3259. *The true proportionate shares of the commonright lands* are to be ascertained on the same principle. For although the ancient regulation respecting commonrights may continue in force, while the commons remain open and unappropriated, it would be found troublesome or unmanageable as a rule to their just appropriation. There are few, if any, commons (of commonfield townships at least) that now afford pasturage in summer for all the stock which the appropriated lands are capable of maintaining in winter; so that their several proportions only could be used; and these proportions may be calculated with much greater certainty and dispatch, on the respective rental values of the lands, than on the more vague and troublesome estimation of the quantities of stock they would winter; which, indeed, would be best calculated by the rental value of the land. Consequently in adopting this, as the basis of calculation, the ancient rule is, in effect, complied with. (*Blackstone*, Book III. c. xvi. sect. 2.)

3260. But although *each commonright occupier has a right to stock in proportion to the productiveness or rental value of his appropriated lands*, every one could not do this with equal profit, and of course could not receive equal benefit. Lands situated on the side of a common are much more beneficial in this respect, than lands which lie a mile or two from it, with bad roads between them; and it is the real advantage which an occupier can fairly receive, that is the true guide in the partition; which consequently ought to be conducted, not on the rental value of the land, abstractly considered, but on this and its situation, with respect to the commonable lands jointly. In other words, it is the rental values of the commonright lands while the commons remain open, not what they will become after the commons are enclosed, which I conceive to be the proper groundwork of appropriation.

3261. *In cases where commonable lands are wholly attached to manors*, and not common to the parish or township in which they are situated, as in forests and woodland districts, the selfsame principle of distribution is applicable. The remainder of the commons (after the owners of abstract rights have been satisfied) belong to the commonright lands and houses; no matter whether such lands and houses belong to copyhold tenants exclusively, or to copyholders and freeholders jointly, provided the immemorial custom of the manor make no distinction in their respective rights; the well established customs of manors being in all cases rules of conduct, and unerring guides to commissioners. Here may be said to end the greater difficulties as to the principles of appropriation; the rest is merely technical; the works of admeasurement, estimate, and calculation; operations that are familiar to professional men in every district, and want nothing but application and integrity to render them sufficiently complete.

3262. *The technical routine of the business of conducting an enclosure* is as follows; The act being passed, and two or more commissioners named, these commissioners meet on a certain day at a certain place within the township or parish, having previously given public notice of their intention. The chief business of that day is the fixing of a land surveyor and an attorney to the commission. At a second meeting the commissioners, surveyor, attorney, and some of the principal proprietors or their agents, attend and make a general perambulation of the township, in order to point out to the surveyor the different properties with their limits, &c. The surveyor now proceeds to make a correct map of the whole. This done, the commissioners, attended by the surveyor, proceed to value each separate lot or piece, and having done this, they next advertise different meetings for the purposes of hearing the rights of townsmen, &c. Next they set about dividing the lands according to these rights, reserving proper roads for footpaths, quarries, gravel-pits, wells, springs, &c. for public purposes. When this is done, and set out on the ground, contractors are next employed to carry the whole into execution, the expense of which and also of the commission is generally paid by the sale of a part of the lands.

## CHAP. III.

*Of the Choice of the Demesne or Site for the Proprietor's Residence.*

3263. *The most desirable situation for the mansion of the owner of a landed estate, will in almost every case be somewhere near its centre.* The advantage of being at an equal distance from every part of the boundaries; of having as much as possible on every side that which we can call our own; of not being overlooked by near neighbors; and of reposing as it were in the bosom of our own tenantry, cottagers, cattle, and woods, are obvious, and felt by every one. There may be instances where, from a public road passing through the centre of an estate, or of a town or village there situated, or mining works carried on, and similar circumstances, it may not be desirable to form a central residence; but such cases are not common, and in laying out an estate newly appropriated, or re-arranging an old one, may always or very generally be avoided. It may happen, however, that an estate may be so extensive, or its surface so hilly or mountainous, that a central situation may be dispensed with for other advantages. When an estate is situated near an extensive lake, at the foot of high mountains, or includes an extent of sea-shore, it will generally be found preferable, in point of effect and enjoyment, to place the mansion near these interesting features. Proximity to the sea, though it be on the margin of our estate, can never be offensive; for if the ocean does not belong to us, neither does it belong to any one else; nearly the same thing may be said of an immense lake, which at least is for the greatest part devoid of visible appropriation, and the same thing may often be observed of rivers and mountains, especially if the latter are of a savage, or wooded character.

3264. *Various other circumstances* must also be taken into view in fixing on the situation of a mansion and demesne; such as its healthfulness, prospects, exposure, water, the nature of the soil, and the extent of territory.

3265. To be *healthy*, a situation should in almost all cases be somewhat elevated above the adjoining surface; and though this cannot be the case with respect to the whole of the demesne lands, it should at least apply to the spot intended for the dwelling-house. Even a level situation is objectionable in point of health, because when the usual plantations have grown up round the house, they tend to stagnate the air and generate moisture, and thus deteriorate the atmosphere, to their own height, which is generally equal or greater than that of the house. Besides, a flat situation can never have views of much beauty, and can only be interesting by the plants or other objects immediately under the eye, and the elevated grounds or hills, if any, in the extreme distance. On an elevated situation, even though surrounded by trees higher than the house, the frequent and varying winds will always prevent the stagnation of the air, and sweep away the accumulation of moisture from the evaporation of so many leaves.

3266. *The nature of the soil* requires to be attended to, even with a view to health. On a level, a gravelly or sandy soil is generally more apt to generate damp in the lower parts of a house, than a clayey soil; but on an eminence gravel has not this objection; in the former case, the water lodged in the stratum of gravel finds its way from all sides to the excavation made for the foundations of the house; in the latter, the declivity on every side carries it away. Clay not too adhesive, chalk, or rock, are the best surfaces to build on in a flat; on an elevated situation any soil will do; but chalk, rock, or gravel are to be preferred.

3267. *The prospects* from the immediate site of the mansion, and from those parts of the adjoining grounds which will be laid out as pleasure-ground, or recreative walks, demand some consideration. Such prospects should consist of what painters call middle and third distances, bold, distinct, and interesting; the fore-ground or first distance being formed by the artificial scenery of the pleasure-ground. Noble features in prospects, are rivers, lakes, or mountains; interesting ones, are churches or their spires, bridges, aqueducts, ruins of ancient castles or abbeys, water-mills, distant towns or cities, distant canals, and sometimes roads, &c.: pleasing rural objects, are picturesque cottages, neat farmeries, field barns, and sometimes distant wind-mills; for objects offensive, when near, often become valuable features at a distance. Something depends on the state of civilisation of the country, and its general character; the sight of a road, sea-port, canal, or even a neighboring mansion, would be preferred to most others in many parts of Ireland, Russia, or America.

3268. *The exposure* with regard to the sun, and the prevailing winds of a country, also requires attention. It was the custom of former times, in the choice of domestic situations, to let comfort and convenience prevail over every other consideration. Thus the ancient baronial castles were built on the summits of hills, in times when defence and security suggested the necessity of placing them there; and difficulty of access was a recommendation: but when this necessity no longer existed (as mankind are always apt to fly from one extreme to the other), houses were universally erected in the lowest situ-



ations, with a probable design to avoid those inconveniences to which lofty positions had been subject; hence the frequent sites of many large mansions, and particularly abbeyes and monasteries, the residence of persons who were willing to sacrifice the beauty of prospect for the more solid and permanent advantages of habitable convenience; amongst which, shelter from wind, and a supply of water for store fishponds, were predominant considerations. (*Enquiry, &c. by Repton, p. 83.*) In hilly countries, or in any country where the surface is varied, the choice is neither made in the bottoms (*fig. 430 a*), nor on the summits of hills (*c*), but generally on knolls, or on the south or south-east side of considerable eminences (*b*), where a raised platform occurs, either naturally or raised by art from the earth of the foundations; and the rising grounds behind (*d*) are planted both for effect and shelter.

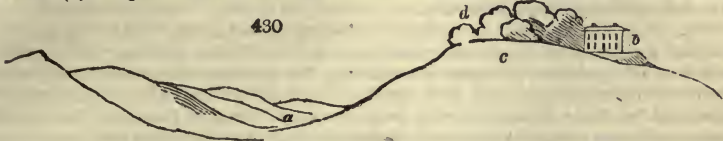

3269. *The proximity of water* is essential to the comfort of every country residence, Where there are none in springs or surface streams, it may indeed be collected from the roofs of buildings and otherwise, and filtered, and preserved sweet and cool in tanks underground; but supplies obtained in this way are precarious, expensive, and the water is inferior to that obtained from the soil, either by local wells, or conveyed from a distance in pipes or drains. Water is also extensively required in country residences for the use of gardeners, sometimes for fish ponds; at a moderate distance, and on a lower level it is always desirable in considerable quantity for the purpose of forming artificial lakes, or river-like reservoirs. Few home features are finer than where the house is situated on a knoll which slopes down on two or more sides, to one encircling piece of water. (*fig. 431.*)

431

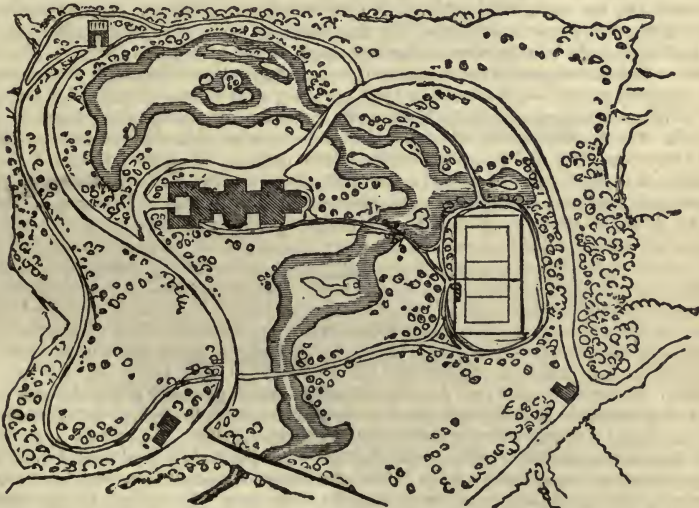

3270. *The nature of the soil* is an inferior consideration to the others, because all bad soils are susceptible of great improvement; but still it should be taken into consideration along with other objects. A soil retentive of surface water, such as some clayey and soft peaty soils, is the worst, as it is always unpleasant to walk on after rains, and easily poached by cattle and horses. Such soils also require more expense in drainage and roads, and are much less suitable for garden and farm culture, than firmer soils, and such as are naturally friable or dry.

3271. *The subsoil* is sometimes of more importance than the soil, for the former in general can only be improved by draining, and subsoils differ materially in their susceptibility of this improvement. A bad subsoil is an effectual barrier to the thriving of timber trees, and as these constitute the finest ornament of every country-seat, the importance of choosing a subsoil either naturally, or capable of being rendered by art pervious by and congenial to their roots, is sufficiently obvious.

3272. *Where the surface-soil is dry and poor, but on a dry subsoil, and all other circumstances are favorable, it may often be desirable for a proprietor to fix on such a situation for his demesne, because such a surface is probably among the least valuable as farm lands; because land to be laid out as a park is not required to be rich; and because it will not be difficult to ameliorate all that part wanted as farm and garden ground.*

3273. *The extent that should be kept as a demesne is more easily determined than any of the foregoing points. The general wealth of the proprietor and his style of living are here the leading guides. The extent of the demesne may bear very different relations to the extent of the estate; because the proprietor may have other estates and other sources of wealth. He may have chosen a small estate, on which to fix his residence, from its local advantages; or he may prefer a small demesne on a large estate, from his style of life and the habits of his establishment.*

3274. *The park, in general, occupies much the largest part of the demesne lands. In a civilized and populous closely-cultivated country, like Britain, nothing can be more noble than a large forest-like park surrounding the mansion. In partially cultivated countries or open field countries, it is less imposing; and in countries scarcely appropriated and but thinly distributed with spots of culture, the park becomes a less noble feature, and less a mark of wealth and distinction than a well-hedged and regularly-cropped farm.*

3275. *The apparent extent of a park depends much less on its contents in acres, than on the inequalities of its surface, the disposition of its woods and waters, and the concealment or inobtrusiveness of its boundaries. An extensive flat, surrounded by a belt, and interspersed with clumps, may be great, but can hardly be felt as grand or interesting, by any but the owner: the acres it occupies will be guessed at by hundreds, and the estimate will generally be found to fall short of the reality. On the other hand, a hilly park, ingeniously wooded with one or more pieces of water, and probably rocks, bridges, and other objects, will appear to a stranger of much greater extent than it really is; and sets rational estimate at defiance: such a park is certainly much more grand and picturesque than one of mere "bulk without spirit vast."*

3276. *The home or demesne farm and farmery will be regulated in extent and style of cultivation by the wants and wishes of the proprietor. It is sometimes a determinate space in the least picturesque part of the demesne; and sometimes, the greater part of the park is brought in succession under the plough and the sickle.*

3277. *The kitchen-garden is the next and only remaining large feature in the demesne: it is generally placed near the house and stable offices, so as to have a convenient and unobtrusive communication with the kitchen court, and the livery-stable dung heap.*

3278. *The pleasure ground, or lawn and shrubbery, often surround the house, offices, and kitchen-garden; and sometimes embrace them only on two or three sides.*

3279. *The details of all these and other different parts of the demesne belongs to landscape gardening and architecture, and requires no further notice in this work. (See *Encyc. of Gard.* Part III. Book IV. and *Encyc. of Architecture.*)*

#### CHAP. IV.

##### *On the Formation of Roads.*

3280. *The advantages of good roads is so obvious and so generally acknowledged, as to need no comment. Roads, canals, and navigable rivers, have been justly called the veins and arteries of a country, through which all improvements flow. The Romans, aware of their importance, both in a military and civil point of view, constructed them from Rome to the utmost extent of their empire. With the dismemberment of that empire, the roads became neglected and continued so during the dark ages. In modern times attention was first paid to them on a large scale by the government of France, in the seventeenth century; and in England in the beginning of the century following. About the middle of the eighteenth century considerable expense had been incurred in road-making, in several districts, and the expenses of toll-gates begun to be felt as oppressive. This produced *An Enquiry into the State of the Public Roads*, by the Rev. H. Homer, &c. 1767, which may be considered as the origin of scientific research on the art of road-making in England.*

3281. *In Scotland, the first turnpike act, as we have seen (750.), was passed in 1750; since which period existing public roads have been improved, and many new ones formed; but the great impulse there was given after the act for abolishing heritable jurisdictions by the money advanced by government, and the able military engineers sent from England to conduct the roads in the Highlands. The appearance in Britain about this time of a new order of professional men, under the name of civil engineers, also contributed to the same effect.*

3282. *In Ireland*, very little attention was paid to the art of road-making before the establishment of the Dublin Society: but the subject was treated of in the early volumes of their transactions, and some useful instructions there given, as it is generally understood, by R. L. Edgeworth; and the surface as well as substrata of that country being singularly favorable for road-making, the art soon began to make considerable progress. This was greatly owing to the exertions of Edgeworth, well known as a scientific engineer and as the author of a tract on roads, published in 1810.

3283. *The extraordinary increase of toll duties* in England having been felt as a very heavy burden by the landed interest during the last twenty years, has drawn the attention of various persons to the subject of roads, and given rise to important improvements; both in laying them out, and in forming and repairing them. By far the most useful of these may be considered the mode of forming, practised since 1816, by L. M'Adam, of Bristol; for which its author was rewarded by parliament. That mode is now with more or less variation adopted in a considerable number of districts in the three kingdoms, and together with the attention and emulation it excites, promises to effect an entire revolution in the state of the public roads everywhere. At the same time it is but candid to state with Paterson, of Montrose, author of two tracts (1819 and 1822) on the subject, that in many districts a considerable improvement had previously taken place in the state of the roads, simply from a greater attention being made to keep them dry, and constantly to obliterate the ruts.

3284. But M'Adam's plan of making roads is not only superior to all others for country roads; but promises to be equally valuable as a substitute for pavement or causeways in towns. It has been tried in some of the principal streets of the metropolis, and will probably soon become general in all the great thoroughfares. (See *Observ. on Roads* by J. L. M'Adam, Esq. 1822.)

3285. In the following view of the present state of knowledge as to roads we shall avoid entirely that part of the subject which relates to national or parochial management, and confine ourselves to the kinds, direction or line, the form, the materials, and the execution, and the repairs.

SECT. I. *Of the different Kinds of Roads.*

3286. Though all roads agree in being tracts of passage from one point to another, yet they differ in their magnitude, construction, and other modes of adaptation, for that purpose. Most good roads consist of two parts; one "metalled" or coated with stones for the use of carriages and horses (fig. 432 a); another of common earth or soil, as a border to the metalled part (b), or for the use of pedestrians; and probably a footpath for the latter (c). Several kinds of roads are distinguished by the relative proportions of these two parts; but some also are characterised by other circumstances.

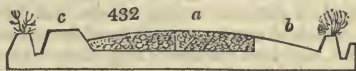

3287. *National roads*, or highways, are such as communicate between the capital cities and sea-ports of a country, and are those of the greatest magnitude. In Britain, the metalled part of such roads where they are most frequented, as within a few miles of large towns, is from 30 to 50 and even to 60 feet wide, with footways on each side of 12 feet wide or upwards, and in no case is the metalled part of the road narrower than 20 feet; that width being requisite to admit of one loaded waggon passing another. Many, or most of these narrower national roads are without footpaths, and often want a sufficient bordering of earth road, or footpath.

3288. *Parochial roads* may be considered as secondary highways, deriving their name from the circumstance of being made and supported by the parish in which they are situated; whereas the others are the work of government, or of the counties in which they are situated, and are supported by tolls levied on carriages and animals, passing over them, whereas the others are supported by parochial rates or assessments.

3289. *Lanes* are parish or private roads generally narrow, and often either not metalled at all, or very imperfectly so; sometimes they are called drift-ways, but that term is more properly applied to the green or unmetalled space, which runs parallel to any made road.

3290. *Estate roads* are such as are made by landed proprietors on their own territory, for the purpose of intercommunication and connection with public roads.

3291. *A farm-road* is either one which leads to a farmery, from a public road, or which leads from the farmery to different parts of the farm. Such roads are never narrower than 16 feet, to admit of two carriages passing each other; but they are often only half metalled, presenting a turf road for summer, dry weather, and for empty carriages and foot passengers, and a metalled or winter road, for winter and loaded carriages. In a road from a highway to a farmery, it may often be advisable to place the metalled road in the middle, and keep the earth road at each side; on account of admitting the sun and

air more readily to the metalled road; but in roads within a farm, it is found a great convenience in casting out manure, or bringing home produce, for the loaded carts to have uninterrupted possession of the metalled road, and the others of the earth road. In many cases, farm roads of this description are only metalled in the horse tracks (*fig. 433 a.*), and wheel ruts (*b, b*), which, on dry firm bottomed land, and with careful preservation, is found to answer very well.

3292. *Horse roads* are paths for the transit of single horses with a rider, or a back load: they are commonly of earth, and from six to ten feet wide: the statute width is eight feet.

3293. *Footpaths* are tracks for pedestrians; sometimes metalled to the width of three or four feet; but often of the natural surface.

3294. *Rail roads* are roads exclusively for the use of carriages, and are characterised by a rail commonly of iron, but sometimes of wood laid along the track of each wheel, in order to produce the effect of a perfectly even surface. In general, the carriages for such roads, have their wheels low, and of a particular construction to fit the rails; but in some cases the rails have grooves for the use of common narrow wheels. Such roads are almost exclusively in use, at coal and other great mineral works; but some have proposed to introduce them as side roads, to the more public highways. For this purpose, also, it has been proposed instead of iron rails, to lay down granite stones of a foot or eighteen inches in breadth, which would render them suitable for any description of wheels or axles.

3295. *Paved roads* are of three kinds; those with small stones, or causeways, which are most common; those with large blocks of stone, and those with sections of timber trees. The first, though almost peculiar to towns, yet form the whole of the metalled road in some cases of country roads; and in others a space of ten or twelve feet in the middle, or at each side is causewayed, for the use of the heavier carriages. Broad stones are sometimes used for covering part of a road, destined for the greatest part of the traffic, or for forming wheel tracks. In the latter case, they are always squared or regularly jointed, but in the former, the most irregular forms may be used. Timber causewaying, is only used in entrance courts, to town mansions, for the sake of avoiding the noise made by the wheels of carriages and horses' feet on stone. For this purpose timber paving is excellent, and lasts for a very long time. On the continent, fine timber is used for this purpose, but oak or larch would no doubt last longer.

3296. *Planked roads* are formed over morasses, or in particular cases by laying down a flooring of planks, on which carriages pass for temporary purposes. A permanent kind of road of this description has been made by weaving (or wattling) an endless hurdle of the breadth of the road, and covering it with a coating of gravel or broken stones. The advantage of this mode is, that the road may be made on a bog before the substratum dries, and even if it is so soft as not to bear a man. By the time the hurdle rots the base will be consolidated and fit to bear any thing.

3297. *Approach roads and walks* are roads which come under the subject of gardening.

3298. The 'term metal' in road making is applied to the stony or gravelly materials laid on to form the main part of the road.

#### SECT. II. *Of the Line of Direction or laying out of Roads.*

3299. *Before carriages of burden were in use*, little more was required than a path upon hard ground, that would bear horses. All marshy grounds were therefore shunned; the fords of rivers were resorted to, and the inequality or circuit of the road was of much less consequence, than when carriages, instead of pack-horses, began to be employed. When carriages were first employed, they probably were light and narrow, and did not require to have roads of any considerable breadth or firmness. And when roads had once been thus traced, indolence and habit prevented any great exertions to lay them out in better lines, or to repair them in any manner beyond what present convenience absolutely required. When heavier carriages and greater traffic made wider and stronger roads necessary, the ancient track was pursued; ignorance and want of concert in the proprietors of the ground, and, above all, the want of some general effective superintending power, continued this wretched practice. (*Edgeworth on Roads*, p. 3.) At length turnpikes were established, and laws passed investing magistrates with authority to alter established lines, so that now the chief obstacle to the improvement of the lines of public roads is the expense.

3300. *In laying out roads*, a variety of circumstances require to be taken into consideration; but the principal are evidently their line or direction, and its inclination to the horizon.

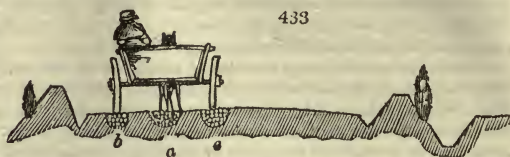

3301. *The most perfect line*, according to Marshal, is that which is straight and level. But this is to be drawn in a country only which is perfectly flat, and where no obstructions lie in the way; joint circumstances that rarely happen. Where the face of the country, between two points or places to be connected by a road, is nearly but not quite level, by reason of gentle swells which rise between them, a straight line may be perfect, — may be the most eligible under these circumstances. But where the intervening country is broken into lull and dale, or if one ridge of hill only intervenes, a straight line of carriage road is seldom compatible with perfection. In this case, which is nearly general, the best skill of the surveyor lies in tracing the midway between the straight and the level line. The line of perfection, for agricultural purposes, is to be calculated, by the time and exertion, jointly considered, which are required to convey a given burden, with a given power of draught from station to station. On great public roads, where expedition is a principal object, time alone may be taken as a good criterion.

3302. *A regular method of finding out the true line of road*, between two stations, where a blank is given, where there is no other obstruction than what the surface of the ground to be got over presents, is to ascertain, and mark at proper distances, the straight line; which is the only certain guide to the surveyor. If the straight line be found to be ineligible, each mark becomes a rallying point, in searching, on either side of it, for a better. If two lines of equal facility, and nearly of equal distance from the straight line, present themselves, accurate measurements are to determine the choice. If one of the two best lines which the intervening country affords is found to be easier, the other shorter, the ascent and the distance are to be jointly considered; the exertion and the time required are to be duly weighed.

3303. *The nature of the ground, the source of materials, and the comparative expense of forming the road*, by two doubtful lines, as well as their comparative exposure, are also to be taken into consideration. Although, in some places, Paterson observes, it may be of little consequence, either to the traveller, or to the public in general, which way the bendings are turned, provided the level is nearly obtained, — yet a great deal may depend upon those turns or bendings for the real benefit and advantage of the road. In bending it one way, you may have no metals that will stand any fatigue, unless at a great distance and expense; while, in turning it the other way, you may have metals of the very best quality, in the immediate vicinity. In the one way, too, you may be led over ground of a wet bottom, where even, with twelve or fourteen inches deep of metals, there would be difficulty in keeping a good road; while, in the other, you may have such a dry bottom, that the road would be much easier upheld with seven or eight inches of metals. So that the tract that may appear most eligible to the eye, at first sight, may not always be the one that should be adopted. “A combination of all the requisites I have already mentioned, should be studied, as far as possible; and where these cannot be found all to unite, the one possessing the most of these advantages, and subject to no other material objection, should, of course, be adopted.” (*Treatise on Roads*, p. 19.)

3304. *Roads*, Edgeworth observes, should be laid out as nearly as may be, in a straight line; but, to follow with this view the mathematical axiom, that a straight line is the shortest that can be drawn between two points, will not succeed in making the most commodious roads; hills must be avoided, towns must be resorted to, and the sudden bends of rivers must be shunned. All these circumstances must be attended to, therefore a perfectly straight road cannot often be found of any great length. It may perhaps appear surprising, that there is but little difference in the length between a road that has a gentle bend, and one that is in a perfectly straight line. A road ten miles long, and perfectly straight, can scarcely be found any where, but if such a road could be found, and if it were curved, so as to prevent the eye from seeing further than a quarter of a mile of it, in any one place, the whole road would not be lengthened more than one hundred and fifty yards. It is not proposed to make serpentine roads merely for the entertainment of travellers; but it is intended to point out, that a strict adherence to a straight line is of much less consequence than is usually supposed; and that it will be frequently advantageous to deviate from the direct line, to avoid inequalities of ground. It is obvious, that, where the arc described by a road going over a hill, is greater than that which is described by going round it, the circuit is preferable; but it is not known to every overseer, that within certain limits it will be less laborious to go round the hill, though the circuit should be much greater than that which would be made in crossing the hill. Where a hill has an ascent of no more than one foot in thirty, the thirtieth part of the whole weight of the carriage, of the load, and of the horses, must be lifted up, whilst they advance thirty feet. In doing this, one thirtieth part of the whole load continually resists the horses' draught; and in drawing a waggon of six tons weight, a resistance equal to the usual force of two horses must be exerted.

3305. *A perfectly level road is not always the best for every species of draught*. Slight and short alternations of rising and falling ground are serviceable to horses moving

swiftly; the horses have time to rest their lungs, and different muscles: and of this experienced drivers know well how to take advantage. Marshal concurs in this opinion, and also Walker, Telford, and most engineers; and Paterson considers that it would not be proper to line a road upon a perfect level, even to the length of one mile together, although it could be quite easily obtained. It is a fact, he says, well known to most people, at least every driver of loaded carriages knows by experience, that where a horse, dragging a load over a long stretch of road, quite level, will be exhausted with fatigue; the same length of a road, having here a gentle acclivity, and there a declivity, will not fatigue the animal so much. This is easily accounted for. On a road quite level, the draught is always the same, without any relaxation: but on a gentle ascent, one of his powers is called into exercise; on the descent, another of his powers is called into action, and he rests from the exercise of the former. Thus are his different muscular powers moderately exercised, one after another; and this variety has not the same tendency to fatigue.

3306. *A dry foundation and clearing the road from water*, are two important objects which, according to Walker (*Minutes of Evidence before a Committee of the House of Commons*, 1819), ought to be kept in view in lining out roads. "For obtaining the first of these objects it is essential that the line for the road be taken so that the foundation can be kept dry, either by avoiding low ground, by raising the surface of the road above the level of the ground on each side of it, or by drawing off the water by means of side drains. The other object, viz. that of clearing the road of water, is best secured by selecting a course for the road which is not horizontally level, so that the surface of the road may in its longitudinal section, form in some degree an inclined plane; and when this cannot be obtained, owing to the extreme flatness of the country, an artificial inclination may generally be made. When a road is so formed, every wheel-track that is made, being in the line of the inclination, becomes a channel for carrying off the water, much more effectually than can be done by a curvature in the cross section or rise in the middle of the road, without the danger, or other disadvantages which necessarily attend the rounding a road much in the middle. I consider a fall of about one inch and a half in ten feet, to be a minimum in this case, if it is attainable without a great deal of extra expense.

3307. *The ascent of hills*, it is observed by Marshal, is the most difficult part of laying out roads. According to theory, he says, an inclined plane of easy ascent is proper; but as the moving power on this plane is "neither purely mechanical, nor in a sufficient degree rational, but an irregular compound of these two qualities, the nature and habits of this power" require a varied inclined plane, or one not a uniform descent, but with levels or other proper places for rests. According to the road act the ascent or descent should not exceed the rate or proportion of one foot in height to thirty-five feet of the length thereof, if the same be practicable, without causing a great increase of distance.

3308. *As precedents for roads through hilly countries*, Telford (*Minutes before the Committee of the House of Commons*, &c. 1819,) refers to those which he has lately made through the most difficult and precipitous districts of North Wales. "The longitudinal inclinations are in general less than one in thirty; in one instance for a considerable distance there was no avoiding one in twenty-two, and in another, for about two hundred yards, one in seventeen; but in these two cases, the surface of the road-way being made peculiarly smooth and hard, no inconvenience is experienced by wheeled carriages. On flat ground the breadth of the road-way is thirty-two feet; where there is side cutting not exceeding three feet, the breadth is twenty-eight, and along any steep ground and precipices, it is twenty-two, all clear within the fences; the sides are protected by stone walls, breast and retaining walls and parapets; great pains have been bestowed on the cross drains, also the draining the ground, and likewise in constructing firm and substantial foundations for the metalled part of the roadway."

3309. *The road between Capel Cerig and Lord Penryn's slate quarries*, may also be adduced as an example of a very perfect enclosed plain in which the ascent is accurately divided on the whole space.

3310. *Cutting through low hills to obtain a level*, is recommended by some, who, as Paterson observes, will argue, "that where the hill of ascent is not very long, it is better, in that case, to cut through it in a straight line, and embank over the hollow ground on each side, than to wind along the foot of it. This, however, should only be done where the cutting is very little indeed, and an embankment absolutely necessary. Few people, except those who are well acquainted, are aware of the great expense of cutting and embanking; and the more any one becomes acquainted with road-making, the more, it may be presumed, will he endeavor to avoid those levels on the straight line that are obtained only by cutting and embanking, and will either follow the level on the curved line round the hill; or where this is impracticable, will ascend the hill, and go over it by various windings, avoiding always abrupt or sudden turnings." (*Treatise*, &c. p. 15.)

3311. *All crossings, intersections, and abuttings of roads, should be made at right angles, for the obvious reason of facilitating the turning from one road to the other, or the more speedily crossing. Where roads cross each other obliquely, or where one road abuts on another at an acute angle, turning in, or crossing, can only be conveniently performed in one direction.*

3312. *In laying out a road over a hill or mountain of angular figure and considerable height, much practical skill as well as science are requisite. In order to preserve a moderate inclination, or such a one as will admit of the descent of carriages without locking their wheels, a much longer line will be required than the arc of the mountain. In reaching the summit or highest part to be passed over, the line must be extended by winding or zig-zagging it along the sides, so as never to exceed the maximum degree of steepness. This may occasion a very awkward appearance in a ground plan, but it is unavoidable in immense works. If a hill, 50 feet in perpendicular height (fig. 434.),*



has an arc (*a, b, c*), or would require 150 feet of road (*a, b, c*) to go over its summit in a straight line, then to pass over the same hill on a road rising at the rate of two inches in six feet (the slope of the Simplon road), would require a length of 600 feet. If this length were extended in a straight line (*d, b, e*) on each side, it would require an enormous mound, and an immense expense; but by being conducted in a winding direction (*b*), up the hill on one side, and down the other, the same end is gained at a moderate cost. Such works shew the wonderful power and ingenuity of man; and perhaps no example exists where this is so displayed in road-making as in the case of the Simplon.

3313. *In laying out a road towards a river, stream, ravine, or any place requiring a bridge or embankment, an obvious advantage results from approaching them at right angles; and the same will apply in regard to any part requiring tunnelling or crossing by an aqueduct, &c.*

3314. *In tracing out winding railroads, or such carriage roads as are only to be metalled in the horse track and paths of the wheels, some management is necessary in the case of quick bends. Where the line is straight, the horse path ought to be exactly in the middle between the wheel tracks. But, where the road winds, and most especially at a quick bend, the horse track ought ever to incline toward the outer side of the curve; by which the wheels will be uniformly kept on the middles of the supports prepared for them. Hence, it is advisable to dig the trench for the horse path (fig. 433 a.), first; and to draw a carriage for which the road is intended, with the horses walking in this middle trench: thus marking out, by the impressions of the wheels, the precise middle lines of the outer trenches, in every part of the road, from end to end.*

3315. *The directions of roads through an extensive estate, cannot be determined on without having in contemplation the other fundamental improvements, such as the situations of villages, farmhouses, mills, or other objects; and these artificial improvements must be taken in connection with the natural surface, soil, materials, waters, &c.; the probable system of agriculture that will be pursued, and the external intercourse. A hilly country under aration, will evidently require more roads than if chiefly under pasture; and, indeed, other circumstances the same, a country abounding in hills and valleys, requires many more roads than one of a more even surface. The roads in such a country are also more expensive, on account of the bridges, and extra work at their abutments. On an estate composed of gentle hills chiefly intended for arable or convertible husbandry, the best situation for the roads will generally be found about half way between the bottoms and highest surfaces. By this means the labor of carting up the produce from the fields below the road, and carting up the dung to the fields above it, is evidently much less than if the road were either entirely on the highest ground or the lowest. Bridges over the brooks or open ditches necessary for drainage in valleys, are also rendered less frequent.*

3316. *Accurate sections of the rises and falls of the natural surface on which a road is to be formed should always be taken before the line is finally determined on. As the figure of an exact section of this sort on any ordinary scale, would convey no data sufficiently accurate for execution, it is usual to adopt one scale for the length, and another for the rises and falls of the road, and to mark the latter with the dimensions as taken on the survey.*

SECT. III. *Of the Form and Materials of Roads.*

3317. *On the structure and composition of roads*, men of science and practical road-makers are much more divided than on their laying out. The subject is of itself of greater importance in old countries, because it more frequently occurs that a road is to be enlarged or renewed, than that a new line is to be devised. We shall first lay down the fundamental principles of the formation, and wear of roads, and next treat of forming them, and of the different kinds of road materials.

SUBJECT. 1. *Of the Formation of Roads, and of their Wear or Injury.*

3318. *A road may be defined a path of transit* on the earth's surface, for men, animals, and machines; — of sufficient width for the given traffick; — of sufficient strength and solidity for the given weight; — of sufficient smoothness to permit no impediment; and of as great durability as possible.

3319. *The width* is obviously determinable by the nature and extent of the traffick: every road should be made sufficiently broad to admit two of the largest sized carriages which are in use in the country or district, to pass each other; and highways and roads near towns should be made wider in proportion to their use. The maximum and minimum can only be determined by experience: sixty feet is the common and legal width of a turnpike-road in Britain, and this includes the footpath.

3320. *The strength of a road* depends on the nature of the material of which it is formed, and of the basis on which it is placed. A plate of iron or stone of the road's width placed on a compact dry soil would comprise every thing in point of strength; but as it is impracticable to employ plates of iron or stone of such a size to any extent, recourse is had to a stratum of small stones or gravel. The great art, therefore, is so to prepare this stratum, and place it on the basis of the road, as that the effect may come as near as possible to a solid plate of material. To accomplish this, the stones or gravel should be broken into small angular fragments, and after being laid down of such a thickness as experience has determined to be of sufficient strength and durability, the whole should be so powerfully compressed by a roller as to render it one compact body, capable of resisting the impression of the feet of animals, and the wheels of carriages in a great degree, and impervious by surface water. But the base of the road may not always be firm and compact; in this case it is to be rendered so by drainage, artificial pressure, and perhaps in some cases by other means.

3321. *The durability* of a road as far as it depends on the original formation, will be in proportion to the solidity of its basis; the hardness of the material of which the surface stratum is formed; — its thickness; — and the size and form of the stones which compose it. The form and size of the stones which compose the surface-stratum have a powerful influence on a road's durability. If their form is roundish, it is evident they will not bind into a compact stratum; if it is large, whether the form be round or angular, the stratum cannot be solid; and if they are of mixed sizes and shapes, though a very strong and solid stratum may be formed at first, yet the wheels of carriages and the feet of animals operating with unequal effect on the small and large stones, would soon derange the solidity of the stratum to a certain depth, and consequently, by admitting rain and frost to penetrate into it, accelerate its decay. A constant state of moisture, even without any derangement of surface, contributes to the wearing of roads by friction, and hence one requisite to durability is a free exposure to the sun and air by keeping low the side fences; and another is keeping a road clear of mud or dust, the first of which acts as a sponge in retaining water, and the second increases the draught of animals, and of course their action on the road. Both the strength and the durability of a road will be greater when the plate or surface-stratum of metals is flat or nearly so, than when it is rounded on the upper surface: first, because no animal can stand upright on such a road with a regular bearing on the soles of its feet; and, secondly, because no wheeled carriage can have a regular bearing, excepting on the middle or crown of the road. The consequence of both these states is the breaking the surface of the plate into holes with the edges of horses' feet, or ruts by the plough-like effect of wheels on the lower side of the road, or the reiterated operation of those which pass along the centre.

3322. *The smoothness* of a road depends on the size of the stones and on their compression either by original rolling or the continued pressure of wheels. The continued smoothness of a road during its wear depends on small stones being used in every part of the stratum; for if the lower part of it, as is generally the case in the old style of forming roads, consists of larger stones, as soon as wheels or water penetrates from above, these stones will work up and produce a road full of holes and covered with loose stones.



3323. *The wear or decay of roads* takes place in consequence of the friction, leverage, pressure, grinding and incision of animals and machines, and the various effects of water and the weather.

3324. *Friction* will in time wear down the most durable and smooth material. Its effects are more rapid when aided by water, which insinuates itself among the particles of the surfaces of earthy bodies, and being then compressed by the weight of feet or wheels, ruptures or wears them. Even when not compressed by wheels or other weights, the action of frost, by expanding water, produces the same effect. This any one may prove by soaking a soft brick in water and exposing it to a severe frost.

3325. *The leverage of the feet of animals* has a tendency to depress one part of the surface and raise up another. The line which forms the sole of every animal's foot may be considered as a lever of the second kind, in which the fulcrum is at the one extremity (fig. 435 a), the power at the other (b), and the weight between them (c). Hence the injury done to the road, even if formed on the best construction, will be as the pressure on the fulcrum: this amounts to the half of the weight of bipeds and their loads, and a fourth of that of quadrupeds. But if the stones of the road are large, that is, if they are more than two inches in breadth, the horse's foot acts as a compound lever, and by depressing one end of the stones and raising the other, deranges the surface of the stratum, and renders it a receptacle for water, mud, or dust.

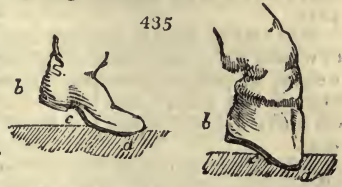

3326. *The leverage of wheels* is of a nature to be less injurious to roads than that of the feet of animals, because the fulcrum (fig. 436 a), is continually changing its position. But if the stones of the road are large, then the wheel acts as a compound lever, and raises up the one end (b), and presses down the other (a), of every stone it passes over, and in this case becomes more injurious on a bad road than the feet of loaded animals. The reiterated operation of this effect by wheels following in the same track, soon destroys badly constructed roads.

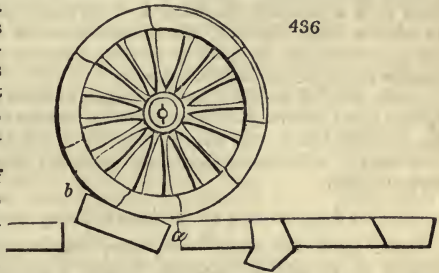

3327. Such being the effect of leverage, and especially of compound leverage, in wearing roads, it becomes of the first importance to ascertain that size and shape of stone on which its effects will be least; that is to say, how short a compound lever may be made use of consistently with other advantages. This must in general be a matter of experience, and chiefly depends on the hardness of the stone. The size must always be sufficiently large, and the shape sufficiently angular to form, when embedded, a compact, hard, and immovable stratum, and the smaller the size the better, provided that object be obtained. Two inches in diameter may be considered the medium size.

3328. *The mere pressure of objects* on a smooth road does little mischief, and hence the advantage of perfectly cylindrical wheels, and a road as nearly level as practicable. But if the surface of the road is rough, the pressure both of cylindrical wheels, and the feet of animals, may do mischief by forcing down a loose stone among others of different sizes, and thus loosening the latter and raising the largest to the surface. Where a road, however, is composed of materials of small size, the pressure of cylindrical wheels, when the surface is clean and dry, will probably always be of greater service by acting as a roller, than of injury by the friction of the pressure.

3329. *Grinding* is produced by the twisting motion of the feet of horses or other animals when pulling hard or carrying a heavy weight, and by the twisting, dragging, or sliding of wheels from whatever cause. The grinding of wheels, Fry observes, "may in every case be defined to be the effect produced on any substance interposed between two bodies, one of which has a sliding motion, yet so firmly confined or pressed between them, that the moving body cannot slide over the interposed substance; but, in consequence of the pressure, the interposed substance, adhering firmly both to the fixed and to the moving body, is necessarily lacerated or torn asunder, and reduced to atoms. This is the process in corn-mills, in drug-mills, and in every other mill, properly so called. I remember," he adds, "frequently when a boy, to have trodden with one heel on a piece of soft brick, or of dry old mortar, which was firm enough to bear the weight of my body, uninjured; but, on giving my body a swing round with my other foot, I have instantly reduced it to powder. The action in this case is very obvious: the weight of my body confined the piece of brick firmly to the ground; my heel was also

pressed by the same weight firmly upon the brick ; one part of the brick therefore remaining confined to the ground, and the other part being carried round by my heel, the brick of course was torn asunder and reduced to powder. This I conceive is a simple elucidation of the difference between pressing and grinding, and this is the difference of the effects on the materials of our roads, produced by the use of upright cylindrical wheels, which act only by *pressure*, by the use of conical wheels, which by their constant twist, act also by *grinding*, and by very convex roads, by which means the wheels of all carriages, excepting such as occupy the crown of the road, whether cylindrical or otherwise, act in the same twisting, sliding, and grinding manner." (*Obs. on Roads, &c.* 1819.)

3330. By the *incision of objects passing along roads*, we allude to the dividing operation of wheels, which, independently of their effect as moving levers, act also as moving wedges, or perhaps, more properly, as endless saws in forming ruts or deepening such as are already made. Flat roads, so as to produce less temptation to follow in the middle track, watchful repair, and broad wheels, are the mitigators of this description of wear.

3331. *Water* is one of the most serious causes of the wear of roads. As we have already observed (3324.), it acts, aided by pressure, like gunpowder in rending the surface of bodies. Frozen it acts exactly in the same manner; and when it has penetrated deeply into a stratum of materials, a thaw produces their entire derangement. Mud is formed in consequence of the presence of water and dust, or earth, and acts as a sponge to retain it, and perpetuate its bad effects. A well-composed and thoroughly compressed substratum will not imbibe water unless it rests in ruts or other hollows. To form such a stratum, therefore, and obliterate all hollows as soon as they appear, and to remove mud and dust, are the palliatives of this mode of wear. On such a road heavy showers may do good by washing away the earthy particles, dung, and other injurious earthy or vegetable matters.

3332. *Wind* is mostly a favorable agent to roads by drying them and blowing off the lighter dust; but in some cases, in very exposed situations, it has been known to blow the dust into heaps, and sometimes to carry off larger particles than could be spared. The last evil is fortunately rare; the other only requires the removal of the accumulated heaps of dust.

#### SUBJECT. 2. *Of M'Adam's Theory and Practice of Road-making.*

3333. *M'Adam* agrees with other engineers, that a good road may be considered as an artificial flooring, forming a strong, solid, smooth, surfaced stratum, sufficiently flat to admit of carriages standing upright on any part of it, capable of carrying a great weight, and presenting no impediment to the animals or machines which pass along it. In forming this flooring, *M'Adam* has gone one step beyond his predecessors in breaking the stone to a smaller size than was before practised, and in forming the entire stratum of this small-sized stone. By the former practice a basement of large stones are first laid, then stones a degree smaller, and, lastly, the least size on the surface. It is in this point of making use of one small size of stones throughout the stratum, that the originality of *M'Adam's* plan consists, unless we add also his assertion, "that all the roads in the kingdom may be made smooth and solid in an equal degree, and to continue so at all seasons of the year." It is doubted by some, whether this would be the case in the northern districts at the breaking up of frosts, and especially in the case of roads not much in use, and consequently consisting of a stratum less consolidated, and more penetrable by water. *M'Adam*, probably, has much frequented public roads in view. "The durability of these," he says, "will of course depend on the strength of the materials of which they may be composed, but they will all be good while they last, and the only question that can arise respecting the kind of materials, is one of duration and expense, but never of the immediate condition of the roads." (*Remarks on Roads, &c.* p. 11.) The following observation of Marshal is worthy of remark, as tending to confirm to a certain extent the doctrine of *M'Adam*. "It may seem needless to repeat, that the surface of a road which is formed of well-broken stones, binding gravel, or other firmly cohesive materials, and which is much used, presently becomes repellent of the water which falls upon it: no matter as to the basis on which they are deposited; provided it is sound and firm enough to support them."

3334. *M'Adam's* theory of road-making may be comprised in the following quotation from his *Report to the Board of Agriculture* (vol. vi. p. 46.). "Roads can never be rendered perfectly secure until the following principles be fully understood, admitted, and acted upon: namely, that it is the native soil which really supports the weight of traffic; that while it is preserved in a dry state it will carry any weight without sinking, and that it does, in fact, carry the road and the carriages also; that this native soil must previously be made quite dry, and a covering impenetrable to rain, must then be placed over it to preserve it in that dry state; that the thickness of a road should only be regu-

lated by the quantity of material necessary to form such impervious covering, and never by any reference to its own power of carrying weight.

3335. *The erroneous opinion so long acted upon, and so tenaciously adhered to, that by placing a large quantity of stone under the roads, a remedy will be found for the sinking into wet clay, or other soft soils, or in other words, that a road may be made sufficiently strong, artificially, to carry heavy carriages, though the sub-soil be in a wet state, and by such means to avert the inconveniences of the natural soil receiving water from rain, or other causes, has produced most of the defects of the roads of Great Britain. At one time M'Adam had formed the opinion that this practice was only a useless expense; but experience has convinced him that it is likewise positively injurious.*

3336. *If strata of stone of various sizes be placed as a road, it is well-known to every skilful and observant road-maker, that the largest stones will constantly work up by the shaking and pressure of the traffick; and that the only mode of keeping the stones of a road from motion, is to use materials of a uniform size from the bottom. In roads made upon large stones as a foundation, the perpetual motion, or change of the position of the materials, keeps open many apertures, through which the water passes.*

3337. *Roads placed upon a hard bottom, it has also been found, wear away more quickly than those which are placed upon a soft soil. This has been apparent upon roads where motives of economy, or other causes, have prevented the road being lifted to the bottom at once; the wear has always been found to diminish, as soon as it was possible to remove the hard foundation. It is a known fact, that a road lasts much longer over a morass than when made over rock. The evidence produced before the committee of the house of commons, showed the comparison on the road between Bristol and Bridgewater, to be as five to seven in favor of the wearing on the morass, where the road is laid on the naked surface of the soil, against a part of the same road made over rocky ground.*

3338. *The common practice, on the formation of a new road is, to dig a trench below the surface of the ground adjoining, and in this trench to deposit a quantity of large stones; after this, a second quantity of stone, broken smaller, generally to about seven or eight pounds weight; these previous beds of stone are called the bottoming of the road, and are of various thickness, according to the caprice of the maker, and generally in proportion to the sum of money placed at his disposal. On some new roads, made in Scotland in the summer of 1819, the thickness exceeded three feet. That which is properly called the road is then placed on the bottoming, by putting large quantities of broken stone or gravel, generally a foot or eighteen inches thick, at once upon it. Were the materials of which the road itself is composed properly selected, prepared, and laid, some of the inconveniences of this system might be avoided; but in the careless way in which this service is generally performed, the road is as open as a sieve to receive water; which penetrates through the whole mass, is received and retained in the trench, whence the road is liable to give way in all changes of weather. A road formed on such principles has never effectually answered the purpose which the road-maker should constantly have in view; namely, to make a secure, level flooring, over which carriages may pass with safety, and equal expedition, at all seasons of the year.*

3339. *An artificial road in Britain is only required to obviate the inconvenience of a very unsettled climate. Water, with alternate frost and thaw, are the evils to be guarded against; consequently nothing can be more erroneous than providing a reservoir for water under the road, and giving facility to the water to pass through the road into this trench, where it is acted upon by frost to the destruction of the road. As no artificial road can ever be made so good and so useful as the natural soil in a dry state, it is only necessary to procure and preserve this dry state of so much ground as is intended to be occupied by a road.*

3340. *The first operation in making a road should be the reverse of digging a trench. The road should not be sunk below, but rather raised above, the ordinary level of the adjacent ground; care should at any rate be taken, that there be a sufficient fall to take off the water, so that it should always be some inches below the level of the ground upon which the road is intended to be placed: this must be done, either by making drains to lower ground, or if that be not practicable, from the nature of the country, then the soil upon which the road is proposed to be laid, must be raised by addition, so as to be some inches above the level of the water.*

3341. *Having secured the soil from under-water, the road-maker is next to secure it from rain-water, by a solid road made of clean dry stone or flint, so selected, prepared, and laid, as to be perfectly impervious to water; and this cannot be effected unless the greatest care be taken that no earth, clay, chalk, or other matter, that will hold or conduct water, be mixed with the broken stone; which must be so prepared and laid, as to unite with its own angles into a firm, compact, impenetrable body.*

3342. *The thickness of such road is immaterial, as to its strength for carrying weight; this object is already obtained by providing a dry surface, over which the road is to be*

placed as a covering or roof, to preserve it in that state: experience having shown, that if water passes through a road, and fill the native soil, the road, whatever may be its thickness, loses its support, and goes to pieces. In consequence of an alteration in the line of the turnpike-road, near Rownham-ferry, in the parish of Ashton, near Bristol, it has been necessary to remove the old road. This road was lifted and re-laid very skilfully in 1806; since which time it has been in contemplation to change the line, and consequently it has been suffered to wear very thin. At present it is not above three inches thick in most places, and in none more than four: yet on removing the road, it was found that no water had penetrated, nor had the frost affected it during the winter preceding, and the natural earth beneath the road was found perfectly dry.

3343. *Several new roads* have been constructed on this principle within the last three years. Part of the great north road from London, by Hoddesdon, in Hertfordshire; two pieces of road on Durdham Down, and at Rownham-ferry, near Bristol; with several private roads in the eastern part of Sussex. None of these roads exceed six inches in thickness; and although that on the great north road is subjected to a very heavy traffick (being only fifteen miles distant from London), it has not given way, nor was it affected by the late severe winter (1819-20); when the roads between that and London became impassable, by breaking up to the bottom, and the mail and other coaches were obliged to reach London by circuitous routes. It is worthy of observation, that these bad roads cost more money per mile for their annual repair, than the original making of this useful new road.

3344. *Improvement of roads*, continues M'A., upon the principle I have endeavored to explain, has been rapidly extended during the last four years. It has been carried into effect on various roads, and with every variety of material, in seventeen different counties. These roads being so constructed as to exclude water, consequently none of them broke up during the late severe winter (1819-20); there was no interruption to travelling, nor any additional expense by the post-office in conveying the mails over them, to the extent of upwards of one thousand miles of road."

3345. *On M'Adam's theory* the only practical road-maker who has published his opinion, is Paterson, of Montrose. He says (*Letters and Communications, &c.* 1822,) "These certainly ought to be considered as the grand first principles of road-making." He commends M'Adam's reasoning on these principles, but objects, as we think with reason, to his drainage of three or four inches as being insufficient. He adds, however, that though he considers M'Adam's system as erroneous and defective in draining and preparing the road for the materials; yet in regard to the materials themselves, the method of preparing and putting them on, and keeping the road free from ruts by constant attention, has his entire approbation. These principles, however, he adds, "are not new; but have been acted upon before. In regard to small breaking, he certainly has had the merit of carrying that mode to greater extent than any other individual that I have heard of; and the beneficial effects arising from it, have consequently been more extensively seen and experienced." (*Letters on Road-making*, p. 49.)

#### SUBJECT. 3. *Road-making as treated of and practised by various eminent Engineers and Surveyors.*

3346. *The subject of forming a road* may be considered as to breadth, drainage, fences, base of the hard materials or artificial stratum, upper line of the stratum, composition of the stratum, size of the materials, laying, and compressing.

3347. With respect to *breadth* the site of every public road, according to Marshal, ought to be sufficiently ample to admit of its division into three travelable lines, namely, 1. A middle road of hard materials, for carriages and horses in winter and wet seasons; 2. A soft road, formed with the natural materials of the site, to be used in dry weather, to save the unnecessary wear of the hard road, and to favor the feet of travelling animals; as well as for the safety, ease, and pleasantness of travelling in the summer season; and 3. A commodious path, for the use of foot passengers, at all seasons. There are few roads, even in the environs of populous towns, so public as to require a hard road of more than two statute poles (thirty-three feet) in breadth; and every public road ought, under ordinary circumstances, to have a line which is travelable at any season, and of ample width to permit two carriages to pass each other, with freedom and safety. This ample width let us set down at one statute pole. In deep clayey districts, where hard materials are difficult to be procured, a single road, of half a pole in breadth, with dilations at proper distances, to let carriages pass each other, may, in many recluse situations, be advisable.

3348. *Seventy feet in width* seems to be considered by Farey, Walker, Telford, and most engineers, as sufficient near the largest towns, and in the case of the metropolis and some others, they consider that ten or twenty feet in width may be paved. The London Commercial road, executed under the direction of Walker, is seventy feet wide; ten feet on each side are occupied as footpaths, twenty feet in the centre is paved for heavy

carriages, and there is fifteen feet of gravel road at each side for light carriages and saddle horses. This road has been executed for sixteen years, and has given the greatest satisfaction; but Walker thinks that considerable improvement would be found from paving the sides of a road, upon which the heavy traffick is great, in both directions, and leaving the middle for light carriages, the carmen or drivers walking upon the foot-paths or sides of the road, would then be close to their horses, without interrupting or being in danger of accidents from light carriages, which is the case when they are driving upon the middle of the road; and the unpaved part being in the middle or highest part of the road, would be more easily kept in good repair. But unless the heavy traffick in both directions is great, one width, say ten or twelve feet, if very well paved, will be found sufficient; and in this case, the paving ought to be in the middle of the road. The width of many of the present roads is, besides, such, that ten or twelve feet can be spared for paving, while twice that width would leave too little for the gravelled part. Although the first cost of paving is so great, he does not think that any other plan can be adopted so good and so cheap in those places where the materials got in the neighborhood are not sufficient for supporting the roads. A coating of whinstone is, for instance, more durable than the gravel with which the roads round London are made and repaired; but much less so than paving; although the freight and carriage of the whinstone, and of the paving-stones, which form the principal items of the expense, are nearly the same.

3349. *Roads ought to be wide and strong*, Edgeworth observes, in proportion to their vicinity to great towns, mines, or manufactories. As they approach the capital, they should be wider and stronger than elsewhere. When a number of roads leading to a great city combine and fall into one, the road from that junction should be proportionably solid and capacious. Near the capital, the width of roads is however often restricted by buildings, that cannot with propriety be suddenly removed, but every opportunity for removing these buildings, and for widening the road, should be attended to, and no future buildings or encroachments should be allowed. And, though in some cases it appears reasonable, to permit the erection of new buildings, and the making new plantations, nearer than thirty feet from the centre of a road, upon condition that security should be given to the public for the constant preservation of the road that is thus injured; it is, however, far safer to prohibit what is injurious to public convenience, than to compromise with individuals: cases of private hardship may, and must occur, but it is part of the true glory of Britain, that there exists no exemption in our laws in favor of the rich.

3350. *Proportioning the breadth of roads to the traffick*, for which they may be employed, is not sufficiently attended to. In remote places, where there is but little traffick, the waste of ground occasioned by superfluous width of roads, is an error of considerable magnitude. There are many places where roads of twenty feet breadth would suit the public convenience, as well as if they were twice as broad. Now it is clear, that if a road is one pole or perch wider than is necessary, there is a waste of 320 perches in a mile, equal to two acres of ground, which, at the rate of three pounds per acre, would, if the road had been once well made, keep half a mile of such road, as is here alluded to, in good repair.

3351. *The breadth of the road and the width of the metals*, according to Paterson, should depend on circumstances different from the former. For a few miles in the vicinity of such cities as London or Edinburgh, the most proper breadth at which a road should be formed, is probably from sixty to seventy feet, and the metals from twenty-five to thirty-five feet. While in the neighborhood of such towns as Newcastle or Perth, it will be sufficient that it be formed forty feet broad, and that the width of the metals be about eighteen or twenty feet. These are the breadths presumed to be the most eligible in such situations. But rules cannot be given to suit every situation: the breadth ought to be regulated according to the extent of the run of commerce, or traffick, upon the road. As a general rule, however, for public roads over the different counties of Great Britain, I should suppose the following might, in most cases, be adopted. Take for instance, the road betwixt Edinburgh and Glasgow, or betwixt Edinburgh and Aberdeen, by the way of Dundee. These roads are formed in general from thirty-five to forty feet wide; and the breadth of the metals is from fourteen to sixteen feet, for the most part. Such roads as these would be found to answer very well, in general, over the kingdom. A breadth sufficient for the general purposes of country travelling, according to M'Adam, is sixteen feet of solid materials, with six feet on each side formed of slighter materials. The Bristol roads, he says, are made with stone about the width of sixteen feet.

3352. *Narrow roads*, it is judiciously observed by Fry, are almost always in bad condition, which is to be accounted for from the circumstance of every carriage being obliged to go in the same ruts; and as each rut is generally only six inches wide, *one foot* of the road only is worn by the wheels instead of the whole breadth of it; which would be the case if the road were of a proper width, and if it were well constructed. If a road be laid out, from twenty to thirty feet wide, so flat as that a carriage may stand nearly upright on every part of it, and if moderate care be taken by the surveyor to prevent the

first formation of ruts, such a road will be worn by the wheels nearly alike on every part of it: provided also that the ground on each side, for at least four or five feet, be moderately flat, so as not to excite fear in the drivers of carriages; but if there be deep ditches close to the sides of the road, or if the circumjacent land fall off very abruptly to the depth of two or three feet, whereby fear of approaching the edges would operate on the minds of the drivers, every driver will instinctively avoid the danger on either hand; and a road so circumstanced will, in spite of any care of the surveyor, inevitably be worn into ruts in the middle. There is a remarkable instance of this kind in a piece of road on Durdham Down, near Bristol. This road is a causeway over a piece of soft ground; and although it is from twenty to twenty-five feet wide, yet, as the ground falls away abruptly on both sides of it, it has been found impossible, for more than twenty years past, to his knowledge, to prevent deep ruts being formed along the middle of it; notwithstanding the Down itself consists of hard limestone; and the other roads upon the Down are as fine and even as any roads in England. Were this piece of road widened out on each side, in an easy slope about five feet, by rubbish of any kind, and by the scrapings of the road itself, whereby the instinctive operation of fear of approaching the sides of the present road would be obviated, that piece of road would be found to wear as fairly as the other roads on the same Down.

3353. In regard to the *drainage of roads*, Marshal directs to examine the site in every part to ascertain whether offensive waters lodge beneath it, as quicksands; or land springs break out in a wet season. If defects of this kind be found, effectual drains are to be run up to them, from the ditches or outer side drains of the site.

3354. *When roads run through marshy ground*, Edgeworth observes, "the substratum must be laid dry by proper drainage; and where the road is liable, from the flatness of the country, to be at times under water, the expense of raising it above the water must be submitted to in the first instance. All drains for carrying off water should be under the road, or at the field side of the fences, and these drains should be kept open by constant attention, and should be made wide at the outlet."

3355. *The side drains*, Telford and Walker recommend to be in every instance on the field side of the fence. In cases, Telford observes, where a road is made upon ground where there are many springs, it is absolutely necessary to make a number of under and cross drains to collect the water and conduct it into the side drains, which should always be made on the field side of the fences. The orifices of these cross drains should be neatly and substantially finished in masonry.

3356. *The method of draining which Paterson has found the most effective*, is thus described: "Before the materials are put on, run a drain along the middle of the road, all the way, from two to three feet deep; then fill it with stones up to the surface, making those at bottom of a pretty good size, and those at the top fully as small as the road materials. And, in order that the quantity of stones used for the said drain may be as little as possible, and every way to save expense, it may be made as narrow as it can possibly be dug. From this leading drain make a branch here and there, to convey off the water to the canals on the sides of the road." This mode of draining he has found, from experience, to be so beneficial, that a road so drained would be better and more durable with eight inches, than it would otherwise be with twelve inches of materials. And, not only so, but that on such a road there would be a saving on the incidental repairs, ever afterwards, of about one-half of the labor, and at least one-third of the material.

3357. *All moisture from under the road materials* must be carried off by such drains. Then, if the materials are properly broken, they will become so firm and solid that little or no water will get through them; and if it should, this drain would carry it away. So that, under any view of it, the utility of these drains must be very apparent: but when we consider that, to have the ground under the road materials perfectly dry, is to insure a good road, these drains become indispensably necessary, and the expense is a mere trifle. There are two miles of road, which were made on this plan under Paterson's directions, which have stood all the winter rains without injury, and which promises to be one of the finest roads in the kingdom. There is another road of ten miles, that he has lately planned, for the greater part of which he has specified *two* such drains, running parallel to each other, and five feet apart. And he would even recommend three or four parallel drains where there is a great breadth of metals, excepting where the road is formed over dry sand, or open gravel. Although the effect of such drains will be at all times beneficial to the road; in time of a thaw, after there has been a few weeks of frost, it will be peculiarly so. In frost, the surface of the road, though wet before, becomes dried, the water being absorbed by the road, or otherwise condensed by the frost. But no sooner is this succeeded by a thaw, than the absorbed, or condensed water, again makes its appearance all over the surface of the road. This is the time that these drains are so *peculiarly* beneficial.

3358. *Where such drains are wanting*, the road, on the return of a thaw, throws up to the surface all the water it had imbibed; and, in many places; the materials

swelling up, become quite loose and open. This is a natural consequence, where the material is not thick, and where the soil under the road is not perfectly dry. But where a road is dried in the way described, it will be uniformly seen, that the water, instead of spewing out on the return of a thaw, is sucked in by the drains, so leaving the surface of the road quite dry. It may be observed, at such times, that the places of the road where a few roods of such drain had been introduced, presented to the eye, at a quarter of a mile distance, quite a contrast to the other parts of the road, — the one opaque and dry, from the moisture being sucked in — the other all wet and glistening, *from its being thrown out to the surface.* (*Puterson's Letters, &c.* 44. 48. 84.)

3359. *The surface-drains, or water-tables,* should be made a few inches lower than the side of the road, and of the common width of a spade at the bottom, and they should have frequent cross drains under the path and fence, back into the outer side drain.

3360. *Water-tables across the road* become requisite in some cases, as in flat roads on a steep slope. These should always be made at right angles to the road, with their sides gently sloping, to occasion as little obstruction to carriages as possible. In some few cases, where roads are liable to floods, or are deficient in drainage, these surface-tables may require to be made of a considerable breadth and paved; in this case Greig (*App. to Strictures on Road Police*, p. 219.) directs to lay six feet of the bottom of it flat, and twelve feet on each side, to rise at the rate of one inch in the foot, which will make the depth one foot; and from the size, no carriage will feel any jerk or shake in passing it. The pavement should be made of hammered stones, of nearly equal depth, each stone from nine to twelve inches long on the surface, and four to eight inches broad, and nine inches to a foot deep; the under-side to be flat in the under-face, and not of an irregular or angular under-surface, as in that case it would not be solid. (*Appendix to Greig's Strictures*, p. 219.)

3361. *Bridges and embankments of different degrees of magnitude,* are required in all lines of road of any length or variety of surface. The subject of large bridges we leave to the engineers; no department of their art having attained higher perfection, of which the wonderful erections by Telford, in almost every mountainous district in Britain may be referred to as proofs. We confine ourselves entirely to such stone arches as may be designed by road-surveyors, and built by country masons. In many cases, cast-iron might be substituted for stone with economy and advantage as to water-way; but though the principle of constructing both cast and wrought iron bridges is perfectly simple, the execution, and especially the putting up, requires more skill, and is attended with much more risk than the erection of either stone or timber bridges.

3362. *One low arch* is in general the most desirable description of common road-bridge. But most of the country bridges, as Clarke observes, consist of several small, high, semicircular arches: where there is a single arch, the stream passes without interruption; if there are two or three in the same situation, the space through which the water is to pass is necessarily contracted by the width of the piers. Ice, and large bodies carried down by floods, frequently stop up the small arches, and the accumulated water carries away the bridge; but if such accidents should not happen, the constant currents rushing against those piers wash out the mortar, loosen the stones, and very soon undermine the work, if it is not extremely well put together, which is seldom the case. Unless the river or stream is narrow, or the banks very high, a semicircle is an inconvenient shape for an arch; it has been adopted on account of the insufficiency of the abutments, and because the pressure is more perpendicular; but scientific engineers in all countries, now construct their bridges with wide openings, and make the arches either semi-ellipses, or segments of large circles — so that the space above the highest floods is comparatively little, and the ascent over the bridge inconsiderable. In country bridges in Ireland, Clarke continues, the foundations are invariably, and often intentionally, defective: the mason considers himself an honest man, if his bridge lasts *seven years*; whereas, from the durability of materials in this country, it ought to endure for ages. Whatever is under water is out of sight, and is generally composed of loose stones, thrown promiscuously together, on which the masonry is erected, and all the pains and expense are bestowed on the *cut-waters* and *wings*, when the heaviest stones, and those accurately jointed, ought to be laid in the foundations. The greatest attention should be paid to the quality of the materials: the stones should be large, and laid in level courses, in the best mortar, composed of sharp sand, free from loam, and quicklime, accurately mixed together; the coping of the parapet is generally so slight, that it is broken down as soon as built, and the entire parapet quickly follows; — it ought to be of large heavy stones, roughly hammered, and there should be substantial quoins at the ends of the parapets with an immovable stone over them.

3363. *Arches not exceeding eight feet span* may be semicircular; tunnels not exceeding eighteen inches wide, may be covered with strong flags, and either flagged or paved under, and there ought to be across either end a deep long stone, sunk below the surface of the current, and under the walls, to prevent the water from undermining the work;

if the stones are square and heavy, those small conduits may be built without mortar, except at the ends.

3364. *In building tunnels* or arches across a road in a flow bog, great pains must be taken with the foundation, or the whole structure will inevitably sink; the building of those should be deferred as long as possible, till the peat has subsided, and has obtained a tolerable consistence; then make an opening equal to the whole work, and sink it eighteen inches below the intended bottom of the arch or gullet; collect a quantity of black thorn bushes, and tie them in faggots of the same size; place these in regular courses in the direction of the road, and lay across them a platform of strong plank three inches thick, the whole length and width of the intended mason work; on this build your arch, and make an allowance in the height of the abutments for sinking. Wherever walls are necessary to support banks, and prevent their crumbling down upon the road, if large even stones can be procured, they will not require any mortar; when mortar is used, there ought to be a great many apertures in the work to give vent to the water, otherwise the pent-up moisture from behind will push out the wall. In many cases, where embankments can be made of earth and sods, they are to be preferred to masonry, which is extremely expensive at the commencement, and very perishable — for mortar soon loses its cementing quality, when exposed alternately to frost and damp.

3365. *Draining the side of a road on a flow-bog*, according to Clarke, is a tedious operation, and often requires some years. A single drain at each side will not be sufficient, as the water from the adjacent moss would fill it up as fast as it was made. Lay out the road here sixty feet wide, which will allow for the banks when the whole shall be finished; make a drain at each side six feet wide, and at a distance of fifteen or twenty feet more, parallel drains of the same width. If the interval between the parallel drains is afterwards cut away regularly for fuel, it will tend still to the condensation of the moss.

3366. *Open drains in the case of ground liable to sink*, or to moulder down by frost, ought to be made very much sloped on the sides, especially the side next the road, otherwise, after repeated scouring out, the road will be found to have sunk at the sides; a very common case, and highly injurious in the case of narrow roads. Whenever this tendency to sink is observed, it should be made up by the scrapings of the road, or by other materials. Roads made over bogs, and artificial mounds, are particularly liable to sink at the sides, which should be immediately counteracted to prevent the bad consequences.

3367. *Fences* along the sides of roads are essential in all enclosed countries; and all engineers and road-makers agree, that they should never be allowed to rise of a greater height than what is necessary for a fence. To give free admission to the sun and air by keeping the fences low, Marshal considers as providing an inexpensive, yet most accurate method of cleaning roads, incomparably more so than washing or scraping. The legislature, Edgeworth observes, has limited, in several instances, the height of hedges to five feet; but this limitation is neglected or evaded. Even were it strictly adhered to, it would not be sufficient for narrow roads; the hedges would be still too high, for it is the sweeping power of the wind, which carries off dust in dry weather, and which takes up moisture in wet. In fact, roads become dry by evaporation; and when they are exposed to the sun and wind, the effect of heat and ventilation are more powerful than any surface drainage that could be accomplished.

3368. Walker observes, that *the advantage of having the hedge next the road*, consists in its greater safety to the traveller, particularly if a ditch of any considerable depth is necessary, and in the hedge being supported in its growth from the ground under the road, without drawing upon the farmer's side of the ditch.

3369. *The fences*, Telford observes, form a very material and important subject, with regard to the perfection of roads; they should in no instance be more than five feet in height above the centre of the road, and all trees which stand within twenty yards from the centre of it ought to be removed. I am sure that twenty per cent. of the expense of improving and repairing roads is incurred by the improper state of the fences and trees along the sides of it, on the sunny side more particularly; this must be evident to any person who will notice the state of a road which is much shaded by high fences and trees, compared to the other parts of the road which are exposed to the sun and air. My observations, with regard to fences and trees, apply when the road is on the same level as the adjacent fields; but in many cases, on the most frequented roads of England, more stuff has been removed from time to time than was put on; the surface of the road is consequently sunk into a trough or channel from three to six feet below the surface of the fields on each sides; here all attempts at drainage, or even common repairs, seem to be quite out of the question; and by much the most judicious and economical mode, will be to remove the whole road into the field which is on the sunny side of it. (*Exam. before the House of Commons, &c.*)

3370. In the *junction of roads*, whether of a bye-road with a principal road, or two bye or principal roads, their respective levels ought, if possible, to be the same, and the materials ought to be rather broader than usual at the point of turning. In like manner



the communication of fields by gates ought to be carefully managed, so as not to injure the public road, the footpath, the water table, or the inner drain. All gates should open inwards to the fields, and not to the road.

3371. That *plantations of trees* should not be made close to roads all are agreed. What the distance ought to be, must depend on the elevation of the country, the soil and subsoil, the breadth of the road, its direction, whether the plantation is to be made on the north or south side of the road, its thickness, kind of tree, &c. An elevated situation is always more exposed to the wind than a level or hollow; and a dry soil and subsoil will always, other circumstances being the same, have a favorable effect on the roads which pass over them. A broad road, and one winding in its direction, has chances of the direct influence of the sun and wind, according to the obliquity of its angles: a road running north and south, though planted closely on both sides, will enjoy the sun during a part of every day in the year; one running east and west, planted on the south side, with trees forty feet high, will enjoy no sun but through the interstices of the branches during the three winter months. Supposing the average height of the sun from ten to two o'clock during these three months to be 20 degrees, then a tree forty feet high will throw a shadow every day during that period, upwards of 100 feet long, which may shew that no plantation should be made nearer the south sides of roads than 80 or 100 feet. On the north-east and west sides, they may be nearer, according to the elevation and natural tendency to dryness of the site, and also taking it into consideration whether the trees are evergreens, and with or without underwood. The least injurious trees are single rows trained to high stems, properly pruned in, or foreshortened.

3372. *The preparation of the base of a road*, for the reception of the metals or hard materials, is a matter of primary importance. Marshal, Edgeworth, and some other writers, with almost all practical men, seem to have entertained much less enlightened notions on this subject than M<sup>r</sup> Adam.

3373. *Marshal's preparation* consists in striking off the protuberances, and filling up the hollow parts: the footpath and the higher side of the soft road being raised with the earth which is required to be taken off the bed of the hard road; whose base or foundation ought to be formed with peculiar care. Every part is required to be firm and sound: dry earth, or hard materials, being rammed into every hollow and yielding part. In a dry situation, as across a gravelly or stoney height, little more, he says, is required than to remove the surface mould, and lay bare the rock, or bed of gravel, beneath it: and, then, to give the indurate base a round or a shelving form, as the lying of the ground may require. In this way, a travelable road may be made, and kept up, at one-tenth of the expense incurred by the ordinary practice in this case; which is to gather up the surface-soil into a ridge, and, on this soft spongy bed, to lay, coat after coat, some hard materials, — fetched perhaps from a distance.

3374. *A soft bed* is now found by far the best, and M<sup>r</sup> Adam has proved in the case of part of the road between Bridgewater and Cross, that a stratum of hard materials covering a morass will last longer than a similar stratum laid on rock: indeed it may be questioned whether a properly made road on a bog, which yields by its elasticity, will not last longer than one on a firm surface. We have been told by a gentleman of some experience in road-making, that in Ireland this is actually found to be the case. "Precisely," as Fry observes, "for the same cause that a stone placed upon a wool-pack would bear a greater pressure before it would be broken, than it would if placed on an anvil." (*Essay on Wheel Carriages, &c. App. 129.*)

3375. *Covering the base of an unsound road with faggots*, branches, furze or heath, is recommended by Edgeworth. Flat stones, he adds, if they can be had, should then be laid over the faggots, and upon them stones of six or seven pounds' weight, and, lastly, a coat of eight or ten inches of pounded stone. If the practicability of consolidating a mass of stones of six or eight ounces weight and under each, so as to act as one plate or flooring, be admitted, then the faggots and flat stones must at least be useless, and the stones of six or seven pounds weight injurious; because whenever the upper stratum had worn down a few inches, some of these stones, and eventually the greater number, would be worked up to the surface, and the road destroyed or put in a state to require lifting, breaking, and relaying.

3376. *A basement of trees, bawns, or bushes*, is made use of by Walker when the ground is very soft. They carry off the water previous to the materials of the road, being so consolidated as to form a solid body, and to be impervious to water. Bushes are, however, not advisable to be used, unless they are so low as always to be completely moist. When they are dry and excluded from the air they decay in a very few years, and produce a sinking in place of preserving the road; a thickness of chalk is useful for the same purpose in cases where bushes are improper, the chalk mixing with the gravel or stones becomes concreted, and presents a larger surface to the pressure.

3377. *The base of the road is constructed by Telford* of an elliptical form; if it is upon clay or other elastic substance, which would retain water, he would recommend to

cover the whole bottom of the road with vegetable soil, in cases where the natural shape of the ground admits; he would not remove the original surface; and where there are inequalities he would fill them up with vegetable soil, so as to cut off all connection with clay.

3378. In *forming the basis of a road on a flow bog*, Clarke directs to strip the heathy sods (tussocks) off the whole surface of the side-drains, and place them with the heath uppermost on the space intended for the road; or if a sufficiency of brushwood or furze can be procured, it will answer still better; proceed to let off the water at the lowest ends of the drains, leaving an open channel in the middle of each; after the water has run off for some time, so as to allow the moss to become somewhat finer, throw off another spit; and repeat this operation month after month, and year after year, till the space for the road becomes compact and dry; and be sure to keep it in that state by cleaning the drains frequently; there should be eight or ten inches of tough clay laid over the tussocks or brushwood, which will be greatly the better to be consolidated by rollers; this part of the road may be left rather higher in the centre than the other parts, to allow for settling. There is no situation where it is more difficult to make a good road than through a flow bog, but if once made well, it is the most permanent of all roads, and from its elasticity, the most easy to horses.

3379. In *forming the basis of a road on thin moor*, the whole of the peat should be removed from the space on which the road is to be made; for, if allowed to remain between the hard subsoil and the small stones, the weight of carriages would press down the latter, force up the black peat through them, and totally spoil the road; this happens only where there is a thin, soft, peaty stratum between two hard bodies, for in deep bog, the elasticity of the foundation yields to the superficial pressure, and contributes to the durability of the materials; after this has been so removed, the surface, when formed and drained, will be ready for the road materials.

3380. In *forming the base or metal bed*, Paterson observes, "it is common to cut it to the exact breadth and depth of the metals, and to make it quite flat in the bottom, or level from the one side of the metals to the other. Supposing this metal-bed to be formed fourteen feet broad, and nine inches deep, on a breadth of fourteen feet, the metals would require to be about three inches higher in the middle than on the sides. In this case then, they would be nine inches deep on the sides, and twelve on the middle; and as it is evident that the middle of the road, where the metals are deepest, is not subjected to so much fatigue and waste from the tread of the horses' feet, as that nearer the sides is from the grinding of the wheels, this is, therefore, a waste of metals on the middle of the road. But this is not the greatest evil of which I complain. The metal-bed being cut into the solid ground, and *flat* in the middle, and having the earth on each side about nine inches higher than it,—this, upon any other ground than that of dry sand or gravel, forms a bed for retaining the water, as well as for holding the metals, which often deluges the middle of the road with mud or gutters, when it might be prevented. I would therefore propose, that a metal-bed of fourteen feet broad should, instead of being level, have a *rise in the middle* of at least four inches, which will make a declivity from the middle to each side of nearly two inches in the yard. Then supposing the surface of the metals to have the same shape as mentioned above, viz. three inches higher on the middle than on the edges, the metals on the sides will be the same depth as formerly mentioned, namely, nine inches; but instead of twelve inches on the middle, they will then only be seven inches deep, which makes a saving of five inches. This saving of five inches on the middle, or two inches and a half on the whole breadth of the metals, is very considerable; but this is not the only benefit arising from this mode of procedure. The metal-bed having a slope from the middle to each side of the road, so far from retaining the water, runs it off from the middle; and this will be of more service in keeping the road in good order ever afterwards, than if you were to put three or four inches more of additional depth to the metals on the common plan. This appears to me to carry so much of common sense on the face of it, that I am surprised it has not ere long this time been generally adopted." Here Paterson seems to infer that water may, or rather does, penetrate the stratum of metal to the base, which, in properly made roads will at least, not often be the case. The argument of a saving in materials is quite sufficient to justify him and Telford in adopting the elliptical form for a basis.

3381. A *soft base* is always preferred by M'Adam, who drains effectually and puts no intervening material between the metals and the earth, even if it were a bog, "provided it admitted a man to walk over it." (*Examination, &c.* 1819.) The Somersetshire morass is so extremely soft, he says, "that when you ride in a carriage along the road, you see the water tremble in the ditches on each side; and after there has been a slight frost, the vibration of the water from the carriage on the road, will be so great as to break the young ice. I never use large stones on the bottom of a road; I would not put a large stone in any part of it, nor faggots, nor any material larger than will weigh six ounces. If a road be made smooth and solid, it will be one mass, and the effect of the

substrata, whether clay or sand, can never be felt in effect by carriages going over the road; because a road well made unites itself in a body like a piece of timber or a board.

3382. *An instructive proof of the preference given by M'Adam to a soft base* is derived from a case which occurred near Montrose. This case was sent to him by Paterson in the following report. "This road," says the reporter, "for about a mile, goes over a bank of sea-beach, many feet in depth, and all round stones from two to five or six inches in diameter. Always as the stones above three inches work up, and make their appearance on the surface, they are taken off to the side of the road, and broken to the ordinary size. This has been done several times every year for many years back, but the road always continues loose and open as ever." The answer of M'Adam was, "I am of opinion that you will not have a good and solid road over this beach, until you have a depth of eight or ten inches of properly broken metals on the surface; and probably it might be an improvement to put under them a few inches of soil, as the bottom is so very loose. But although the great mass of stones, over which this road is made, is of the best quality, yet as the greater part of them are under three inches diameter, I am afraid that were they even broken to my size, they will not bind together as if broken from larger stones."

3383. *M'Adam's Answer.* — "The road you have sent me a report of, is novel in its situation, but very far from hopeless. The sea-beach, of which it is wholly composed, should be picked; that is to say, the large sized pebbles should be carefully removed from the surface, and carried to the side of the road, and there broken, not to what your surveyor calls my size, which is six ounces, but smaller, say to three or four ounces. And I must also warn you, that any round stone, when broken in half so as to form a hemisphere, is nearly as unmanageable and as little likely to consolidate in a road, as one left quite round; therefore, with regard to weight, your stones must be taken so as to form as many angles as possible. No large pebble must be left in sight upon the bottom of the road, otherwise they will work up through the broken stones, of which your road will be composed; but having prepared a surface upon which to place your road, by removing the large sized pebbles (I mean all above six ounces), and even covering the surface with sand soil or other soft matter, lay on your properly broken stones." Paterson entirely concurs with M'Adam in regard to the advantage of a soft base, adding in his last publication (*Letters, &c. 1822.*), "although the ground under the materials can never be too dry, the materials never unite so firm when placed upon a hard rock, or upon gravel, as they do upon earth, moss, or sand. There should always, therefore, be a few inches of the one or the other of these, put under the road as a bed for the materials, where it is on a rocky or gravelly bottom."

3384. *When the basis consists partly of firm, and partly of loose materials, or moved earth, some nicety* is required to determine the allowance for the sinking of the latter, and indeed roads, under such circumstances, cannot often be finished out of hand. Some judicious directions on this subject are given by Paterson. "When a road," he observes, "is formed along the side of a hill, or sloping bank, the earth that is produced from the side-cutting makes up a part of the breadth of the road; so that the road is formed, partly on the solid ground, and partly on the embankment. All new-made-up earths, or embankments, subside a little, whatever be the nature or quality of the stuff of which they are composed. For which reason, that part of the breadth of the road, that is formed upon the embankment, should be raised a little higher than the solid ground. No precise rule can be given to ascertain exactly how much the different kinds of earths, clays, gravel, &c. will subside; but the following has been found so near to the truth, in most cases, that it may with safety be admitted as a general rule.

3385. At all places where there are embankments, whether over hollow ground, or along the side of a sloping bank; for every foot that these embankments or mounds are raised in height, one inch may be allowed for subsiding. So that if an embankment, or the outer edge of a road formed from the side-cutting, requires, for instance, six feet deep of forced earth to bring it to the level required, in that case it should be made six inches higher, — namely, six feet six inches upon the newly-made-up ground. And it will be found, in general, to be about six months, from the time that the embankment has been made, until it has become properly consolidated together.

3386. *The materials of the road* may be considered in regard to their nature or kind, the proper size and weight; the outline of their upper surface, and the mode of laying them on, and consolidating them.

3387. *Stone* is universally allowed to be the best kind of material for roads, and granite, trap, or flint, the best species; next in order are some sorts of limestone, and hard sandstone. Soft claystone is the worst. Limestone is the principal material in Wiltshire, Somersetshire, Gloucestershire, and Ireland; Granite and trap in the north of England and Scotland; slatestone in North Wales; sandstone pebbles in Shropshire and Staffordshire; flint in Essex, Sussex, and part of Kent; and gravel in Middlesex and Surrey. "The stones used for the metals of any road," Paterson observes, "should always be the

hardest and most durable that the place or neighborhood can afford. But this durability will be found in a great measure to depend on the dryness of the road. Freestone, of a moderate hardness, such as chemists would term No. 6., 'that would with difficulty yield to the knife,' will make a very good road on a dry sloping bank, exposed to the sun and air, or even on a level surface that has a dry gravelly bottom. Nay, even seven or eight inches deep of such metals on such situations, will make a better road than twelve inches of the best metals, where the bottom is constantly damp, and will actually surpass it in point of durability. This, however, is not meant to give a preference to those metals, but merely to show the great difference there is betwixt a wet and a dry bottom; and that such metals will answer very well in the situations above described. Still it must be held as a general rule, to take the best and hardest metals the neighborhood can afford, as formerly mentioned."

3388. But *the hardest metals will not always be found the most durable*; and here it may be remarked, as another general rule, with some exceptions, that the worse they are to break, the greater their durability. Some stones, for instance, as hard as No. 9. of mineralogists, "such as would give a few feeble sparks with strit," are so free that they will fly under the stroke of a hammer like so many pieces of glass. These, although very hard, being of a quality so free and brittle, will grind down by the wheels rather easily, and in time of rains will be formed into mud; while, on the other hand, there are stones not harder than No. 7. that are so tough, that there is great difficulty in breaking them. Yet these latter, although two degrees softer, will absolutely last longer than the former, on any road whatever.

3389. *Flints* reduced to a small size, and mixed with chalk, make an excellent road in dry weather; but chalk being very absorbent of water they become slippery and soft in moist weather, and are much affected by frost.

3390. *Whinstone*, M'Adam, and all road engineers, agree in considering the most durable of all materials; and wherever it is well and judiciously applied, the roads are comparatively good and cheap. Fry, however, has uniformly observed, in various parts of England, that where limestone is used, the roads are the best, and this superiority is not in his opinion owing merely to the hardness of this substance, but also to its adhesive or cementing property: how, otherwise, he says, are we to account for the firmness and solidity of the roads around Bristol, that are made of white limestone.

3391. *Gravel* is of two kinds, that obtained from pits, and that from the beds of rivers. Gravel is generally silicious and hard; otherwise indeed it would have been worn down to sand, in undergoing the operation which has rendered it gravel. This material is chiefly used on the roads round London: it is often found, Paterson observes, "to answer very well in point of durability. But such kind of gravel, being composed chiefly of hard sand, and smooth, little, round stones, does not so easily bind together, and seldom make a very firm road. On the other hand, stones that are broken have so many sides that they readily lock into one another; whereas the small round gravel keeps rolling and shifting about by every motion of the wheels. All road metals, therefore, should be of stones as large as to require breaking before they are used. The roads on which gravel will be found to answer best, are those which are neither too wet nor too dry. I have seen a road made with such kind of materials, not only easily rutted in time of the winter rains; but the same road, in the drought of summer, became as loose as ashes, and was then also very easily rutted; while in a medium betwixt these two extremes, it answered exceedingly well. Upon the whole, it would be improper to use gravel for any turnpike or public road, where stones can be got that require to come under the hammer." (*Treatise, &c.* p. 31.)

3392. *The gravel of which roads are usually formed*, is mixed with a large portion of clay, and because the component parts of gravel are round, and want the angular points of contact, by which broken stone unites, and forms a solid body; the loose state of the roads near London, is a consequence of this quality in the material, and of the entire neglect, or ignorance of the method of amending it.

3393. *Gravel is the worst material for making roads subject to great traffick*. Telford, on being asked his opinion of it by the road committee, replied, "I am of opinion that the materials in the whole valley or plain round London being entirely silicious, or flints, and easily ground to dust, are very improper. This must be evident to every person who travels near London in any direction." In this opinion M'Adam concurs.

3394. *Artificial materials* for roads are sometimes had recourse to, when stone or gravel is not to be procured, and sometimes used because unfit for any thing else. They are chiefly the scoria of founderies, dross, cinders, &c., to which may be added burnt clay; the last a very perishable material. It is burned in clamps like bricks, and differs from them in being in irregular masses, and in not having been previously worked.

3395. *The preparation of materials* relates chiefly to their proper size or weight, and cleaning from earthy matters.

3396. *Breaking the materials evenly* is a point, Marshal observes, on which very much depends. For by doing this, the wear of the road becomes regular. Where the heads of large stones rise above the general surface, they become obstacles to carriages, and stumbling blocks to horses: beside their tending, by the jolting motion which they give to carriages, to indent the surface on either side of them; and thus to increase the roughness, and hasten the decay of the road.

3397. *The proper sizes of road stones* requires much latitude. Not only the intended use of the road, but the nature of the material, is to be considered. A road for broad-wheeled carriages of burden, only, may be made of larger stones than one for narrow wheels. And hard stones require to be broken smaller than those which more readily wear down, and form a travelable surface. For when once the surface of the materials becomes united and cemented together, and its rock-like texture established; the stones that are crushed, and the smaller fragments which are splintered off, in wear, serve to encrust and bind together the stratum of stones which lie next, in succession, beneath: especially if proper attention be paid to the irregularities of wear, and to bring back the surface, wherever it is requisite, to its original evenness of convexity: so that it may, in every part, act as an arch, and may be able to resist, with the greatest firmness, the weight with which it may be impressed.

3398. *In forming and repairing roads, with stones of size*, a considerable share of the expense arises from the labor of reducing the materials; and, in consequence, the smaller they are broken, the greater becomes the expense. This, on ordinary occasions, is a serious consideration. Hence, in constructing and repairing common roads, it is advisable, — instead of reducing the surface stones to small fragments, with the hammer, at a great cost, — to cover them with materials that are already reduced; as the rubbish of stone quarries, soft stones or gravel, or the scrapings of the road to be repaired. Such cementing materials being washed and worked down, by rains, and the action of carriages and the feet of travelling animals, among the surface stones, assist much in binding and fixing them in a firm crust; and in making the road immediately passable, by horses and light carriages: most particularly, if the whole be compressed, and united together, with a heavy roller (suitable to the purpose) repeatedly passed over the surface. Such is Marshal's opinion; how much it differs from M'Adam's and Paterson's, cannot but be remarked by the reader.

3399. *The size of stones preferred by Edgeworth*, is not specifically mentioned; but on bones, he would lay stones of six or seven pounds weight: he elsewhere observes, that no stones larger than inch and a half diameter should be left on the surface of the road.

3400. *The size which Walker approves of*, he has not given in very definite terms; and his observation as to the foundation acting by an arch is in our opinion erroneous. He says, "Where whin or other stone is to be used, the size of the pieces into which it is broken should decrease as we approach the surface, the superficial coating not exceeding a cube from one inch to one inch and a half. If the foundation is bad, breaking the bottom stone into small pieces is expensive and injurious, upon the principle I have above described, and also for the same reason that an arch formed of whole bricks, or of deep stones, is to be preferred to one of the same materials broken into smaller pieces; for in some counties the materials will admit of the foundation of the road being considered as of the nature of a flat arch, as well as of being supported by the strata directly under it.

3401. *The size of metals, according to Paterson*, should be different for the upper and under surfaces of roads: and both should be regulated according to the situation of the road, and the nature of the ground over which it is formed. "Such small broken metals as are most proper for a road formed on a sloping bank, or on a very dry bottom, would be quite improper for a road that is perfectly level, and is much subjected to dampness. In the former case, even six or eight inches deep of such metals will make a good road; but in the latter case, twelve or fourteen inches will be found inadequate. In the former case, too, the metals should be of such a size as may fill and pass through a ring from two to two inches and a half in diameter; and in the latter cases, they should not be under three inches; as under that size I have never found them to make a durable road in such situations. Every road that has more than eight inches deep of metals, should have the half of these in the bottom broken considerably larger than those on the top. If the road, however, has a dry hard bottom, there is not so much need for this; but if the bottom is soft and wet, it is of the greatest service in making a firm road, and preventing the metals from sinking: and the softer the bottom, the larger, of course, they should be." But it is to be remarked, that the same author in his *Letters*, &c. published three years afterwards, says, "In my former treatise I proposed, where the bottom was soft, to have the under course of stones a little larger than those at top. This I have seen of service, in several cases: but my mode of draining, which should never be neglected, supersedes this entirely.

3402. *The criterion of size adopted by M<sup>r</sup> Adam, is six ounces, or under, for every part of the stratum.*

3403. *The size approved of by Clarke is not defined, but it should, he says, be small. "The common practice is to lay a stratum of stones nearly the size of a man's head, as a foundation, and to cover them with two or three inches of smaller ones; but, from experience and observation, I am decidedly of opinion, that all the stones should be small, and as nearly as possible of the same size, for though a road made as above described, may be very good at first, the wheels of carriages will grind the small stones to powder, the large ones will then rise to the surface, and the road will become intolerably rough; and though frequently repaired with new materials the same cause will produce a similar effect; whereas, if all the stones are small, and nearly of the same size, they will soon be cemented into one solid mass, and will be worn evenly to the last, so that no repairs will ever be necessary, but the addition of a few broken stones occasionally." (Obs. on Roads, p. 11.)*

3404. *The mode of preparing gravel is nearly the same by all the best road engineers, who agree with Telford, that it ought to be completely cleansed of every particle of clay or earthy substance, and its different sizes ought to be selected and arranged by means of riddling or washing. In the use of the riddle, the particles of earth or clay adhere so much to the stones that it frequently requires to be exposed to the sun, air, and frost for several months, and then riddled over again. In this gravel, the stones are of different sizes and different shapes; all those that are round ought to be broken with a small hammer. Some attempt to attain the same end sooner by washing; but this is both a more expensive, and less effectual mode than that of taking advantage of the weather.*

3405. *The mode of breaking stones recommended by Edgeworth is by persons sitting, and using small hammers. A hard stone should be used as an anvil, and the stone to be broken may be advantageously held in a forked stick. Attempts have been made some years ago to break limestone for roads, by the force of horses, wind, and water. Stampers, shod with iron, and raised by proper mill-work, were employed; they were let to fall upon blocks of whinstones. These mills were found profitable for breaking limestone to powder, as a manure, where fuel was scarce, but they crushed the stone to dust rather than to fragments; if lighter stampers were employed they frequently failed to break the stone. Feeding the mill was also found difficult and dangerous. This unsuccessful attempt should not discourage mechanics from farther trials. Stones previously broken to the size of five or six inches, might be thrown upon a strong circular horizontal grating, made of cast-iron. The stones might be forced downwards through this grating by an iron rammer on an edge; they would thus be broken to fragments that could not exceed a certain size, and that would not be reduced to powder.*

3406. *The manner of breaking, according to Telford, is of great importance. More depends, he says, on the weight, shape, and manner of using hammers than any one can conceive who has not had much experience in road-making; the difference in managing this operation being not less than ten per cent.; and is, besides, of equal importance towards the perfection of the road; the size and weight of the hammer he would apporportion to the size and weight of the stones, and the stones should be broken upon the heap, not on the ground. It must be evident that using round stones instead of broken ones, will be the means of deranging the position of those near them, and of grinding them to pieces.*

3407. *According to M<sup>r</sup> Adam the only method of breaking stones both for effect and economy, is by persons sitting; the stones are to be placed in small heaps, and women, boys, or old men past hard labor, must sit down with small hammers and break them, so as none shall exceed six ounces in weight.*

3408. *Breaking by machinery. On a new line of road, between Bury and Bolton, in Lancashire, a rotatory steam-engine is attached to a machine similar to a stone-mill, but considerably stronger, which breaks the stones to cover the road at the astonishing rate of seventy or eighty tons in ten hours. The engine is moveable on wheels, so that it can be removed to any part of the road without being taken to pieces. (London Journal of the Arts, &c. Sept. 1822.)*

3409. *M<sup>r</sup> Adam's criterion for size is weight. On being asked by the road commissioners to mention the dimensions, he stated, that there was very little difference in the weight of the stones used in road-making. "I did imagine," he says, "that a difference existed, but having weighed six ounces of different substances, I am confident there is little difference in appearance and none in effect; I think that none ought to exceed six ounces; I hold six ounces to be the maximum size. If you made the road of all six-ounce stones it would be a rough road; but it is impossible but that the greater part of the stones must be made under that size." "Do you find a measure or ring through which the stones will pass, a good method of regulating their size?" — "That is a very*

good way, but I always make my surveyors carry a pair of scales, and a six-ounce weight in their pocket, and when they come to a heap of stones, they weigh one or two of the largest, and if they are reasonably about the weight, they will do; it is impossible to make them come exactly to it."

3410. *With respect to the size of stones*, Paterson disapproves of six ounces being made the maximum as proposed by M'Adam. "I find," says he, "there are many under the weight that are yet of a very improper shape and size; even from three to four inches between the extreme points. Besides, scales for weighing are not so portable nor convenient, as gauging rings for the size. The ring I generally use is two inches and a half in diameter; and the stones should be broken so that the largest may pass, in any direction, through it. On this plan you have the materials smaller, more equal, and more square in shape than on his plan. An inexperienced person, on the first view of it, may think otherwise; but it is a fact, that taking my ring as a gauge, you will not have five stones in a thousand that will exceed four ounces in weight; and none of improper shape or dimensions; while on Mr. M'Adam's plan you will have more than twenty in a thousand that will not pass longitudinally, even through a three inch ring. It is now nearly three years since I first heard of his standard weight. During that time I have had people both working to it, and also to my ring-gauge; but I have uniformly found, that mine are so much smaller that they cost about a *fifth* more in breaking than his. Upon the whole, then, I would recommend the ring as every way preferable to the scales: and I have no doubt that it would be an improvement even to reduce the ring a little where the ground under the road is so completely dried by the method I have described."

3411. *With respect to the depth of metals*, Marshal mentions twelve inches; but Edgeworth considers an average of nine inches as sufficient for any road on a good basis; and two thirds of the quantity, he says, will make an excellent road at a distance from any great town.

3412. *The depth of materials, according to Walker*, depends so much upon the soil and the nature of the materials themselves, that it is impossible to lay down any general rules for them. The thickness ought to be such that the greatest weight will not affect more than the surface of the shell, and it is for this purpose chiefly, that thickness is required, in order to spread the weight which comes upon a small part only of the road over a large portion of the foundation.

3413. *The depth of solid materials recommended by M'Adam* is ten inches, which he thinks equal to carry any thing when well consolidated, and whether on a soft or hard substratum; he should prefer a soft one. (*Examinations, &c.* 1819.)

3414. *The depth of metals, according to Paterson*, should be regulated according to their quality, the situation of the road, and the nature of its basis. On the generality of turnpike roads it should be made from ten to twelve inches; and upheld afterwards at the depth of nine or ten inches. Yet, in some situations, even six or eight inches will make a much better road than twelve or fourteen in other situations.

3415. *With respect to the shape of the surface of the metals*, almost all road-makers agree that it should be convex, but they differ a little in the degree of convexity. It is also allowed by most of them that on roads up ascents, the surface of the metals may be flat, bevelled, or somewhat inclined to one side. Concave roads are not here taken into account as they require a different general plan, and may be considered as not resorted to in preference, but from accidental circumstances.

3416. *The proper convexity of a wet-weather road, according to Marshal*, is to be regulated by a variety of circumstances: as, first, by the materials of which it is to be formed: soft materials are most liable to be worn into ruts and hollows, and require to be laid up with a quicker descent for rain-water, than hard materials; which require less elevation or rotundity of surface; and least of all a firm even pavement. Secondly, a convex road in the face of a steep is to be laid up higher, with a given material, than one on more level ground, on which rain-water has no other tendency than to the sides; whereas, in the face of a steep, it may have an equal or greater tendency along the line of the road; and is liable to be caught by the slightest impressions of wheels; and thus to wear channels, as may too often be seen, from the top to the bottom of the hill. Even where the surface of the road is perfectly smooth, it may have twice the distance to run, before it reach the outer margin, that it has on a level. And, thirdly, the degree of convexity is to be determined, in part, by the width of the road; the materials and descent being equal. A wide road requires to be formed with a greater sideways descent, than a narrower one; which more readily frees itself from rain-water; inasmuch as the distance is shorter from the crown to the outskirts of the road. Nor is freeing a road from rain-water the only object to be kept in view, with regard to its convexity. The ease and safety of carriages, and particularly those of burden, whose loads, being of light materials, are laid up high, require to be consulted. A carriage moves

most freely, and with the least exertion of draught, when the load lies evenly upon the wheels on either side. In proportion as the weight is thrown on one side, or the other, the resistance is increased; especially on a road which is liable to impression. Hence, an inconveniency of a highly convex road in the face of a steep; and hence the utility of breaks in long ascents.

3417. *It is evident that every part of a road should be equally and duly convex; should be equally safe and easy for carriages of every description, otherwise it becomes more partially worn; the more level parts only are used, the steeper being in a degree useless. Hence, a road of even and due convexity is not only easy and safe, but may be formed of a narrower width, than one whose steep sides are neither easy nor safe to be travelled, and whose crown only is in use. On measuring different passages of roads which appeared to lie in the most desirable form, Marshal found that their convexity, or the elevation of the crown or middle of the road above the base line, in roads of twenty feet in width, was about ten inches; namely, one inch in every foot on either side. And he is of opinion that this result may be taken as a general guide in forming roads, this middle degree of convexity being liable to be altered, according to the width of the road, the nature of the materials, and the other circumstances.*

3418. *A whole barrel or convex road cannot easily be kept up in a narrow site, as in the case of narrow lanes. If raised, it presently wears into a middle track and two wheel-ruts, with foul drains on either side of them, and becomes, in wet weather, a dirty trough, which is unfit for either carriages or horses, and in which a foot passenger has not where to set his foot. But if such a lane be thrown into a shelving form, resembling half a barrelled or convex road, a greater width of travelable road for carriages and horses will be obtained; ruts will not be so liable to be formed; the whole of the water of rains will be thrown to one side, while the other will afford a comfortable walking path, at all seasons. It is to be remarked, that when water in a wet season is apt to ooze out of the banks on the upper side of the lane, a narrow channel is to be cut, to prevent its overflowing the road; or, in forming the bed of the road, the inclination may in some cases be reversed, so as to throw the drain on that side of the lane from whence the spring water issues: thus the same drain will serve for the spring and the rain-waters.*

3419. *Semi-convex roads are applicable not only to narrow lanes, but to the sides of hills, where the road, as it generally ought, is conducted sidelong (not directly) up the slope. By this form of the road, the whole of the water which falls upon it will be got rid of without inconveniency or expense. And the bed of the road for this purpose may be made narrower than for a full convex road, a circumstance which in some cases may become a saving of much expense. The upper side of a road in this form being nearly level, and firm to the foot of the steep, would be chosen by ascending carriages, while the lower side would acquire a looseness of surface, and be used by laden carriages going downward; and while a raised footpath on the lower margin would be a secure guard, and a relief to the apprehensions of timorous travellers.*

3420. *The convexity of a road, according to Edgeworth, need be no more than what will prevent it from being worn hollow, before it can be conveniently repaired; and he very judiciously assigns as a reason, that no lateral inclination of the ground, consistent with the safety of carriages, would empty a rut of three inches deep. So far from this being the case, whoever attends to the fact will find, that even down a moderate slope, where any dirt remains upon the road, the water will be obstructed. Even if there are no ruts on a road, the mud and sludge will not run down aslope even of two degrees, which is the utmost inclination that should be permitted on a mail coach road.*

3421. *The degree of convexity preferred by Benjamin and John Farey, is twelve inches in a road fifty-five feet wide; but to attain this shape when the road is worn down in first forming, there should be a rise in the centre of sixteen or eighteen inches.*

3422. *The degree of convexity preferred by Walker is just a sufficient rise towards the middle, to incline the water towards the sides; and in place of making the whole width the section of one curve, to form it by two straight lines, forming inclined planes, and joined by a curve towards the middle. I have seen, he says, "ridges formed in what I thought well-farmed land, much after what I would recommend for the form of a road. The object of forming the land into ridges, raised a little in the middle, is the same as that of raising the middle of a road to prevent the water from settling upon it; and what is sufficient for the ploughed land, is certainly enough for a road. If the road is of good stone, four to five inches rise in ten feet is sufficient; gravel and other inferior material, will allow a little more. This shape not only assists the water to pass from the centre towards the sides, but greatly contributes to the drying of the road, by allowing the action of the sun and air to produce a great degree of evaporation. Surveyors ought to use a level in giving roads a proper shape, in order that the surface may be of one uniform curvature, without the smallest deviation, in any one spot, from the prescribed line of the cross section."*



3423. *The degree of convexity proposed by Clarke, a young Irish road surveyor, is still less than that of Telford.* Were it not absolutely necessary, he says, to let the rain-water run off quickly, the best shape for a road would be a flat surface, and, therefore, the nearer we can approach to that form the better; for, if the road is much elevated in the centre, wheel carriages will all run in the middle, and, of course, very soon wear that part into deep ruts; and if they are then forced to go upon the sides, almost the whole weight will press upon the lower wheel, which will, of course, sink deeper, and occasion a distressing resistance to the shoulder of the horse at that side; therefore, as before observed, the flatter a road can be made, consistently with a moderate fall for the rain-water to escape, the more convenient and durable it will be; for a road should be as hard and as smooth as possible. An idea of a perfect road may be formed from a frozen canal, where flatness, smoothness, and hardness are combined: in imitation of such a surface railways were invented, and fully illustrate the principles assumed. Roads cannot be made so as fully to attain those perfections; but we should always have them in our view; for the nearer we approach to such a standard, the less will be the friction, and the greater the facility of draught. On a site of sixty-three feet he forms a metalled road of thirty-four feet, with a rise of nine inches in the middle; a six-foot path at one side, and a ditch and bank at each side, occupying ten feet six inches. (*fig. 437.*)

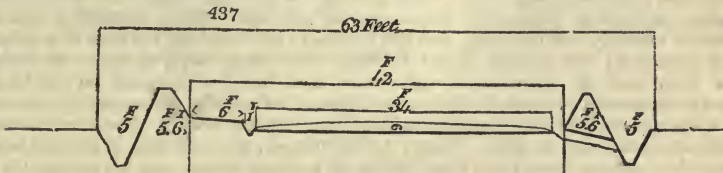

3424. *The convexity preferred by Telford is no more than is just sufficient to permit the water to pass from the centre towards the sides of the road; the declivity may increase towards the sides, and the general section form a very flat ellipsis, so that the side, at the time, should (upon a road of about thirty feet in width) be nine inches below the surface in the middle.*

3425. *The degree of convexity preferred by M. Adam, is less than that approved of by any of the road engineers mentioned, unless perhaps Edgeworth.* "I consider," he says, "that a road should be as flat as possible without regard to allowing the water to run off at all, because a carriage ought to stand upright in travelling as much as possible. I have generally made roads three inches higher in the centre than I have at the sides, when they are eighteen feet wide; if the road be smooth and well made, the water will run off very easily in such a slope. When a road is made flat, people will not follow the middle of it as they do when it is made extremely convex, which is the only place where a carriage can run upright, by which means three furrows are made by the horses and the wheels, and the water continually stands there: and I think that more water actually stands upon a very convex road, than on one which is reasonably flat."

3426. *If a road be high and convex in the middle,* Fry observes, no care of the surveyor can prevent the formation of a pair of ruts along the ridge of the road; from an instinctive operation of fear every driver will take this track, as being the only part of the road where his carriage can stand upright; and even if it be not so convex as to excite fear, yet the inconvenience of travelling on a sloping road will always produce the same effect.

3427. *The convexity recommended by Paterson on the level ground, where the bottom is dry, should be from one inch to one inch and a half in the yard.* From this, the declivity may increase even to three inches in the yard, just in proportion as the ground increases in wetness; but beyond that declivity it would probably be improper to carry it in any instance. If the bottom, however, is dry sand or gravel, the convexity should be very little indeed. But, in all cases, whether wet or dry, a road formed on sloping ground, should be very near level from side to side. The reasons are obvious. In the first place, it is well known that carriages running quickly over a hill, are more easily overturned than on level ground; it would therefore be dangerous, in this respect alone, were the road to have much slope on the sides. In the next place, as the great end in giving it the convex shape is to run off the water and prevent it from lodging, this is not so necessary on a road formed upon sloping ground, as there the water will not lodge so as to injure it. In his second work, (*Letters, &c.*) Paterson observes of the above directions, "In my treatise respecting the *form* of the road, I proposed the slope from the edges of the materials, to the side ditches, to be from one inch to an inch and a half in the yard, where dry; and to increase the slope a little, where wet. But by adopting those drains under the road, no greater slope will be required, in any situation, than an inch to the yard.

3428. *With respect to the order and mode of laying out the materials*, there is some difference of opinion. Some begin with the largest, and finish with the very smallest, or with gravel; some lay on the whole at once, and others in two or more stratum, and so on. That such a mode of depositing materials could never make a good road, is evident, for the reasons given by M'Adam and Clarke; the larger stones would soon rise to the surface, and roll about loose on it; the stratum being thus broken up, would admit and retain water, which, by the traffick of the road, would render the substratum, in all such places, a mass of mud, and the whole would become bad in proportion to the traffick, the subsoil, and the climate. Marshal is equally wrong in his directions for forming farm-roads, by filling the wheel-tracks with hard materials. In depositing these, he says, the largest and roughest are to be thrown to the bottoms of the wheel-trenches, as foundations for the hardest, which ought to receive the immediate pressure of the wheels, the softest and finest being disposed of in the horse-track. It is evident the continual action of the wheels in the same rut, aided by the water which must infallibly lodge there, would soon work up the larger and rougher stones, and render the traction more oppressive than if no metals had ever been laid there.

3429. *Telford's mode of disposing of the materials of roads* is as follows: — Where a road has no solid and dry foundation, it must be constructed anew. Upon the eighteen centre feet of it stones must be put, forming a layer seven inches deep. Soft stones will answer, or cinders, particularly where sand is prevalent. These bottoming stones must be carefully set by hand, with the broadest end down, in the form of a close, neat pavement; the cavities should be filled with stone chips, to make all level and firm, and no stone should be more than five inches broad on its face. Over its bottoming of stones or cinders, six inches of stones, of a proper quality, broken of a size that will, in their largest dimensions, pass through a ring of two and a half inches diameter, must be laid. The six feet of the road, on each side of the eighteen centre feet (making thirty feet), when formed of a proper shape, may be covered with six inches of good clean gravel, or small stone chips.

3430. *No covering or mixture of any sort is added to the material by Edgeworth*, except clean angular gravel, that may insert itself between the interstices of the stones; but no more should be used than what will thus sink to a level with the surface. If the whole were covered with gravel, it would be impossible to discover the defects of the road, till it might be too late. No stones larger than an inch and a half diameter should be suffered to remain on the road; where much inaccuracy in this respect is suspected, an iron ring may be employed as a gauge. In all cases, after the road has been covered with stones, it should be carefully examined, and every stone that is too large should be picked off, to be broken smaller.

3431. *The preference generally given to gravel*, Paterson considers to be greater than it deserves, and that the earth obtained from the sides of the road, free of expense, will not only barely answer the purpose, but in most cases equally well; and that on a perfectly dry bottom, it is questionable whether it should not even be preferred to gravel. It is in winter only, and on wet ground, that I consider gravel entitled to any preference whatever. (*Treatise, &c.* p. 43.)

3432. *The mode of laying on gravel, according to Walker*, “is to lay it on as it comes from the pit, excepting the upper foot, or eighteen inches or so, which is screened; but in all cases, whether the material is gravel or hard stone, the interstices between the pieces should be filled up solid with smaller pieces, and the finishing made by a thin covering of very small pieces, or road-sand or rubbish, for those interstices must be filled up before the road becomes solid, either in this way or by a portion of the materials of the road being ground down, which last mode occasions a waste of the material, and keeps the road unnecessarily heavy and loose. In the original making or effectually repairing of a road, it is, I think, best that the whole of the proposed thickness be laid on at once, for the sake of the road as well as of the traveller; the materials of the road then form a more solid compact mass than when they are laid in thin strata at different times, for the same reason that a deep arch of uniform materials is preferable to a number of separate rings.” Laying on a stratum of unsifted gravel, under a sifted stratum, is rather at variance with the doctrine of “a deep arch of uniform materials;” and it seems to us, that when a stratum of properly broken stones are to be powerfully rolled, the previous filling up of their interstices with very small matters might counteract the effect of rolling, in squeezing the angular stones into the angular interstices.

3433. *The mode of laying on gravel by M'Adam*, is that of scattering with a shovel, and never emptying down cart or barrow-loads on the middle of the roadway, as is generally practised. He completes the stratum by three separate layers, leaving the first to be consolidated by wheels, and in some cases a heavy roller, before he lays on the second; and the second, in like manner, before he lays on the last.

3434. A covering from four to five inches thick, according to Fry, forms a bed or mass, which is proof against the severe crush of heavy wheels, while in the case of a very thin covering, the stones lying bare upon a hard road, and receiving in this unprotected state the stroke of every wheel that passes over them, like the thin covering on a mill-bed, they are quickly reduced to powder, and disappear. Stones in a thick bed are protected from the immediate destructive grind; while stones that are thinly laid on are instantly reduced to powder, either by pressure or grinding.

3435. Telford, in filling broken stones, and also in scattering them on the road, makes use of a pronged shovel, fourteen inches square, which may be universally recommended for this purpose (fig. 438 d). His large hammer (a), small one (b), and gauge for the size of the broken stone (c), are in very general use, as well as the pronged shovel. Hammers may be made of cast iron where the stones to be broke are about their own weight; the best shape is a narrow oval; the advantage of using cast iron is its cheapness. (*Farm. Mag.* xxii. 159.)

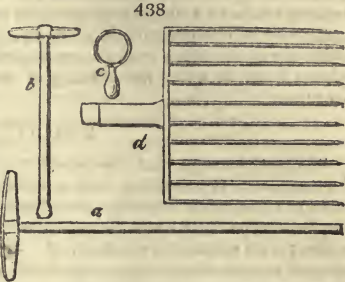

3436. Telford's level for adjusting the declivity of roads from the middle to the sides (fig. 439), is also a very complete implement of the kind.

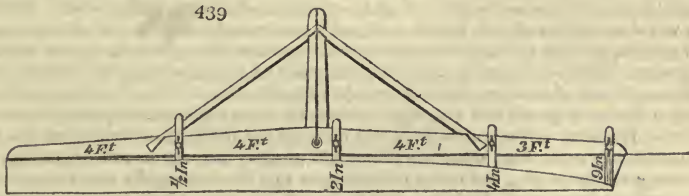

3437. The mode of depositing materials by Paterson is as follows:—"Bottom metals should be broken on the road. When they are thus broken, they are, by the force of the hammer, firmly bedded into the bottom, and are so closely and compactly beaten together, that they become like pavement. In this state they are not only less liable to sink, but they form a much better bed for the top metals than when they are thrown loosely on. And besides this, when they are put on in a loose manner, as is frequently done, the mud more readily works up through the metals in time of rains, and makes a disagreeable road: the top metals also are easily beaten down by the horses' feet and the carriages, through the bottom stones, when loose and open; so that the small metals frequently get undermost, and the large ones make their appearance at the surface, very much to the injury of the road. Taking all these circumstances, therefore, into consideration, it is of the greatest importance that the bottom metals should not only be much larger in size, but that they also be broken on the road." This may be considered as at variance with several parts of Paterson's second publication. (*Letters, &c.*) The road being drained and prepared for the materials, he then directs (p. 80.) to put them on in the following manner:—"M'Adam's mode of putting them on in coats of three or four inches, though good in particular instances, will not do as an universal rule. If the bottom is wet, and the weather rainy, the earth will poach and work up through the materials, in spite of all the attention and care that can be bestowed. I would, therefore, recommend in such cases to put on the first course from five to six inches thick. But then to leave these materials to consolidate, or rather to move and shift about by the wheels; and then to be levelled by the rakes, alternately, according to M'Adam's plan, wears away the corners of the stones, by which means they do not unite together and make such a firm road. There were upwards of two miles of road made under my directions lately, on which I caused a course of about six inches to be put. But before opening it to the public, I got a heavy stone roller to ply upon it for four days. This beat and firmed the materials so much, that the wheels of the carriages made little impression upon it. Of course the materials retained their angular points more than in rolling and shifting by every carriage-wheel that passed; and there was less labor in raking and levelling the road. This plan, which carries reason in the face of it, I would strongly recommend. As to M'Adam's plan of putting on the materials in shovelfull, it is certainly good. I used to prohibit putting them on with carts (as in that case you never have the small and the great properly mixed together), and generally put them on with wheel-barrows. But even this does not mix them quite

so well as to scatter them with the shovel; and as it is of considerable importance to have them well mixed, I would by all means recommend the mode best calculated for that purpose."

3438. *Rolling newly laid on metals* is generally approved of. The roller used should not be less than of four or five feet in diameter, a smaller size, especially in the use of gravel, being apt to drag and force the loose materials before it. Some have attempted to keep roads in order by occasionally harrowing and then rolling them; but the best judges are of opinion with John Farey, (*Evidence, &c.* 1819) that a roller cannot be beneficially used upon a road at any other times but after new coating it with materials, or after a frost, or when the sticking of materials to the wheels may have loosened up the stratum.

#### SECT. IV. *Of paved Roads.*

3439. *Causeways and pavements* are chiefly made use of in towns, and may therefore be considered as belonging more to architecture than to agriculture. But as it is the opinion of some of the first engineers that pavements might be introduced with advantage on the public roads for some distance from the larger towns, we shall shortly consider this subject with reference to that object. Paving, as applied to roads, is therefore to be considered as a substitute for a part or the whole of the metalled part of the road, and not as occupying every part of its width or site, as in the case of streets.

3440. *For roads near capital or great commercial towns*, paving, according to Edgeworth, is the only certain method yet known that gives sufficient hardness, smoothness, and permanency to a road. B. and J. Farey are of the same opinion, and the latter considers it would be proper to pave the sides of all the principal entrances into London. Walker, who was the engineer of the Commercial road, ten feet of the centre of which is paved with granite, and has given great satisfaction for upwards of 16 years, is a great advocate for paving. The advantage, he says, of paving part of a road where the traffick is great, and the materials of making roads bad or expensive, is not confined to improving the conveyance for heavy goods and reducing the horses' labor; but as the paving is always preferred for heavy carriages, the sides of a road are left for light carriages, and are kept in much better repair than otherwise they could possibly be. It is not overstating the advantage of the paving, but rather otherwise, to say, that taking the year through, two horses will do more work, with the same labor to themselves, upon a paved road, than three upon a good gravelled road, if the traffick upon the gravel road is at all considerable, and if the effect of this, in point of expense, is brought into figures, the saving of the expense of carriage will be found to be very great when compared with the cost of the paving. If the annual tonnage upon the Commercial road is taken at 250,000 tons, and at the rate of only 3s. per ton from the docks, it could not upon a gravelled road be done under 4s. 6d., say however 4s., or 1s. per ton difference, making a saving of 12,500*l.*, or nearly the whole expense of the paving in one year. The introduction of paving, therefore, would, in many cases, be productive of great advantage, by improving the gravel road, reducing the expense of repairs, and causing a saving of horses' labor much beyond what there is any idea of.

3441. *Telford* considers that it would be of advantage to pave a part of the centre of great public roads; and in conformity with this principle, when forming a gravel road, he lays eight or ten feet of it in the centre with stones.

3442. *The part of the road most desirable to be paved*, according to B. Farey, is the sides. "If the centre was paved," he says, "the light carriages would be much annoyed; when the gravel road was good on the sides, the heavy carriages would go there, and the light carriages would be driven on the stones from the sides again; if the centre was paved, the carters would be obliged to walk on that road to manage their horses, and would be considerably annoyed by carriages, horsemen, &c. passing: but if the sides of that road were paved, the carters would be enabled to walk on the foot-path, and to manage their horses without annoyance."

3443. *Paving the sides* is also preferred by J. Farey, "but not the middle, as has been done on the Commercial road, and Borough stones and road. My reasons for preferring the sides being paved are, that it is next to impossible to compel the carters to keep upon the pavement in the middle of the road, in too many instances; the fear of damage, from the swift going carriages, occasions them either to draw their carts close to the sides, and walk upon the footpaths, or, what is worse, to leave their horses in the middle, beyond a train of carriages. The sides being paved, would enable one of those trains of carriages to enter London on one side of the road, and go out of it on the other, without many occasions to turn out of their tracks, which circumstance of keeping nearly to the same tracks, upon a well-paved road, would not be prejudicial; but on a road formed of gravel is entirely ruinous."

3444. *Walker also prefers paving the sides*, though in the case of the Commercial road he paved the centre, as already described (3440.).

3445. *Paving the whole or any part of a road is entirely disapproved of by M'Adam.* "The measure," he says, "of substituting pavements, for convenient and useful roads, is a kind of desperate remedy, to which ignorance has had recourse." The badness, or scarcity of materials, cannot be considered a reasonable excuse; because the same quantity of stone required for paving, is fully sufficient to make any excellent road any where: and it must be evident, that road materials of the best quality may be procured at less cost than paving stone. The very bad quality of the gravel round London, combined with want of skill and exertion, either to obviate its defects, or to procure a better material, has induced several of the small trusts, leading from that city, to have recourse to the plan of paving their roads, as far as their means will admit. Instead of applying their ample funds to obtain good materials for the roads, they have imported stone from Scotland, and have paved their roads, at an expense ten times greater than that of the excellent roads lately made on some of the adjoining trusts. Very few of these pavements have been so laid as to keep in good order for any length of time; so that a very heavy expense has been incurred without any beneficial result, and it is to be lamented that this wasteful and ineffectual mode is upon the increase in the neighborhood of London.

3446. *The practice of paving roads* has also been adopted in places where the same motive cannot be adduced: in Lancashire, almost all the roads are paved at an enormous cost, and are, in consequence, proverbially bad. At Edinburgh, where they have the best and cheapest materials in the kingdom, the want of science to construct good roads, has led the trustees to adopt the expedient of paving to a considerable extent; and at an expense hardly credible, when compared with what would have been the cost of roads on the best principles.

3447. *The advantages of good roads, when compared with pavements, are universally acknowledged;* the extension of pavement is therefore to be deprecated as an actual evil, besides the greatness of the expense. Pavements are particularly inconvenient and dangerous on steep ascents, such as the ascent to bridges, &c. A very striking example of this may be observed on the London end of Blackfriars bridge, where heavy loads are drawn up with great difficulty, and where more horses fall and receive injury than in any other place in the kingdom. The pavement in such places should be lifted, and converted into a good road, which may be done with the same stone at an expense not exceeding 10*d.* per square yard. This road would be more lasting than the pavement, and, when out of order, may be repaired at less than one-tenth of the expense which relaying the pavement would require. This measure has been adopted with great success, and considerable saving of expense, in the suburbs of Bristol, where the pavements were taken up, and converted into good roads, about three years ago. The same thing has lately been successfully adopted on Westminster and Blackfriars bridges.

3448. *In preparing for laying down pavements,* the first thing, Edgeworth observes, to be attended to is the foundation. This must be made of strong and uniform materials, well rammed together, and accurately formed to correspond with the figure of the superincumbent pavement. This has no where been more effectually accomplished, than in some late pavement in Dublin. Major Taylor, who is at the head of the paving board, before he began to pave a street, first made it a good gravel-road, and left it to be beaten down by carriages for several months; it then became a fit foundation for a good pavement. The Romans, in preparing for pavement, laid a substratum of masonry in some cases two or more feet thick, and never less than a foot or eighteen inches. This mode is adopted in one or two cases near St. Petersburg, and might be advantageously used in this country were not the expense an objection. Planking, broad stones, iron plates, slates, tiles, and brick work has also been proposed in this country; but a consolidated stratum of broken stone of ten inches in thickness is perhaps the simplest and best preparation, especially for the sides of roads. A substratum of sand is sure to be deranged after the first rains.

3449. *The kinds of stone used in paving* are chiefly granite, whinstone or trap, Guernsey or other pebbles, or water worn granitic or trapstones. Walker prefers the granite of Guernsey to that of Aberdeen.

3450. *The size of the stones used in road pavements* is commonly from five to seven inches long, from four to six inches broad, and from six to eight inches deep. Walker prefers stones nine inches deep; and Telford is of opinion that the general shape of the stones at present used for paving, and the modes of distributing them, are very imperfect, the lower part of the stones being of a triangular wedge-like shape, which, instead of enabling them to resist the weights which come upon them, easily penetrate into the substratum; the stones are also broken of an unequal size. The remedies for these defects are obvious; they should be as nearly as possible of a cubical form, the lower bed having an equal surface with the upper face; they should be selected as nearly as possible of an equal size, and they should never be of equal length on the face. In quarrying and preparing the stones there would certainly be an additional expense in the preparation, because there would be more work required in the dressing, and many stones must

be rejected which are now used; but the additional expense would be very well bestowed.

3451. *In laying down the stones*, each stone, according to Edgeworth, should bear broadly and firmly on its base; and the whole should be rammed repeatedly, to make the joints close; the upper and lower sides of the stones should be as near each other as possible, but they should not touch each other laterally, except near the top and bottom, leaving a hollow in the middle of their depth, to receive gravel, which will serve to hold them together. This method of paving may be easily executed by common workmen, who may throw in gravel between the stones as they are laid down. It may be easily conceived, that if a grain of gravel inserts into holes that are in stones opposite to each other, they will *dowel* them together. It will be useful to cover a newly-made pavement with gravel, which will preserve the fresh pavement for some time, from the irregular pressure of wheels, till the whole is consolidated. It should be observed, that the stones should be of equal hardness, or the soft ones will be worn down into hollows. In every species of paving no stones should be left higher or lower than the rest; for a wheel descending from a higher stone will, by repeated blows, sink or break the lower stone upon which it falls.

3452. *The requisites for laying down the stones* and forming a good pavement are, according to Walker, to have the stones properly squared and shaped, not as wedges, but merely as rectangular prisms; to sort them into classes according to their sizes, so as to prevent unequal sinking, which is always the effect of stones, or rows of stones, of unequal sizes being mixed together; to have a foundation properly consolidated before the road is begun to be paved; to have the stones laid with a close joint, the courses being kept at right angles from the direction of the sides, and in perfectly straight lines; the joints carefully broken, that is, so that the joint between two stones in any one course shall not be in a line with or opposite to a joint in any of the two courses adjoining. After the stones are laid they are to be well rammed, and such of the stones as appear to ram loose, should be taken out and replaced by others; after this the joints are to be filled with fine gravel, and if it can be done conveniently, the stability of the work will be increased by well watering at night the part that has been done during the day, and ramming it over again next morning. The surface of the pavement is then to be covered with an inch or so of fine gravel, that the joints may be always kept full, and that the wheels may not come in contact with the stones while they are at all loose in their places. Attention to these points will very much increase both the smoothness and the durability of the paving. He has found great advantage from filling up, or, as it is called, grouting the joints with lime-water, which finds its way into the gravel between and under the stones, and forms the whole into a solid concreted mass. The purpose served by the lime might also be effectually answered by mixing a little of the borings or chippings of iron or small scraps of iron hoop, with the gravel used in filling up the joints of the paving. The water would very soon create an oxide of iron, and form the gravel into a species of rock. He has seen a piece of rusty hoop taken from under water, to which the gravel had so connected itself, for four or five inches round the hoop, as not to be separated without a smart blow of a hammer; and the cast-iron pipes which are laid in moist gravel soon exhibit the same tendency.

3453. *As substitutes for paving stones*, plates of cast iron moulded into the form of the surface of a pavement of different sizes, (*fig. 442 c, d, e*), have been tried; but on the whole they are not considered as likely to succeed. They are very hot in summer and more slippery than stone in winter; but what is most against them is, that the water finds its way beneath them and softens the substratum. This, at any time of the year, tends directly to produce holes by the leverage of the wheels and feet of animals (3325.); but after a severe frost the effects are ruinous. At all events this description of pavement does not appear so well adapted for the sides or middle of public roads as that of granite stones prepared in Telford's manner (3450.).

3454. *Various improvements in laying pavements* have recently been devised, such as laying the stones dry on clay, using square stones, or stones equally wide at bottom as at top, using stones alternately wider at bottom and top, and joining them with cement (*fig. 440.*), paving on plates of iron, wood or stone, or on a mass of masonry, &c. If pavements in towns did not require to be frequently lifted on account of sewers, and water and gas pipes, paving in this manner on a solid foundation would certainly be the best mode; but as things are, and even probably if pavements did not require to be frequently lifted, M'Adam's roads are found greatly preferable for all broad streets, and where attention is had to keep them clean and in complete repair. In Britain at least, they will probably soon supersede all common pavements, and all other description of common roads.

440



3455. Large blocks of granite (fig. 441.) have been substituted for common-sized paving stones; each block is two or more feet square, nine inches deep, and channelled on the surface in imitation of common-sized paving stones. These are found to answer much better than the cast iron plates; but they are liable to the same objection as to leverage; are difficult to replace properly; and as the raised panels between the grooves will in time wear down to the level of the grooves, they cannot be considered so durable as common square stones; which after all appear the best for general purposes, and at all events for paving the middle or sides of highways.

441

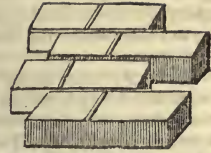

3456. The defects of common pavement and the theory of its wear, are thus given by Edgeworth. "Stones, in a common pavement, are usually somewhat oval, from five to seven inches long, and from four to six inches broad. They are laid in parallel rows on the road (fig. 442 c, d), or alternately (a, b), as bricks are laid in a wall. On the first sort of pavement wheels slip from the round tops of the stones into the joints between, and soon wear away the edges of the stones, and their own iron tire. By degrees, channels are thus formed between some of the stones, and in time the pavement is ruined.

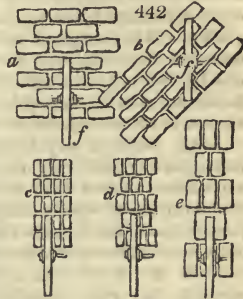

3457. On the second sort of pavement (a, b), where the stones are placed alternately, to prevent the injury to which the former method is liable, the wheel (f) sliding sideways, makes a channel between two stones, and is then obliged to mount from the groove which it has made, to the top of the stone opposite to it; when it has attained this situation, the wheel may slide sideways, or may go forward over the top of the stone, till it drops into the interstice between the two next stones. By continual wearing, these ruts become so wide and deep, that the wheel does not touch the stones on either side, nor does it reach the ground between them, but it bounds from one stone to the other, thus jolting the carriage in every direction. This method is not at present in use.

3458. In the pavements hitherto described, the stones are but of a small size; but if flat stones of twelve or fourteen inches long (e) are well laid, wheels are not liable to slide into the joints; and if such stones are laid with their longest sides crossing the road they are less liable to injury; but still narrow wheels sometimes fall into the joints between the largest stones, and having in time worn away their own edges, and those of the stones, they will act like wedges, and will displace the stones. No pavement, of the best stone that could be procured, can long resist this action of a narrow wheel. And the only effectual means of preserving pavement is, to increase the breadth of all wheels to at least three inches. Were no wheels narrower, a cheap and durable pavement might be made of flat stones, not more than three inches square, provided they were eight or nine inches deep, to give them reciprocally lateral support; for the tire of such broad wheels could never sink between the joints of the stones. (Edgeworth.)

SECT. V. Of Railroads.

3459. Railways or tramroads are not intended to be considered here as connected with mines, canals, or other works which come directly under the province of the higher branches of engineering; but merely as substitutes for the whole or a part of the metallated surface of common roads. The necessity of an expeditious and cheap mode of conveying coals from the pits to the ships, had, as early as the year 1680, introduced the use of wooden railways, for the waggons to move upon, between the Tyne river and some of the principal pits, and these by degrees became extended to a great number of other coal-works. They were first solely employed for transporting coals to a moderate distance from the pits, to the places where they could be shipped, being universally made of wood. By degrees they were, however, carried to a farther extent; the scarcity of wood, and the expense of their repairs, suggested the idea of employing iron for the purposes of improving these roads. At the first, flat roads of bar-iron were nailed upon the original wooden rails, or as they were technically called, sleepers; and this, though an expensive process, was found to be a great improvement. But the wood on which these rested being liable to rot and give way, some imperfect attempts were made to make them of cast iron, but these were found to be liable to many objections, until the business was taken in hand by Outram, an engineer at Butterly Hall, Derbyshire, who contrived at the same time, so far to diminish the expense, and improve the strength of the road, as to bring them to a degree of perfection, that no one who has not seen them can easily conceive could have been done. This having been carried into execution in a few cases, and found to answer, has been improved upon and simplified by practice, till it is now brought to such a state of perfection as to have

given proofs, that it admits of being carried much beyond the limits of what was for many years conceived to be possible, and to afford demonstrative evidence, that it may be in future employed to a wider extent still, to which no limits can be at present assigned or foreseen.

3460. *In countries the surfaces of which are rugged, or where it is difficult to obtain water for lockage, where the weight of the articles of the produce is great in comparison with their bulk, and where they are mostly to be conveyed from a higher to a lower level; in these cases, Telford observes, iron railways are in general preferable to canal navigation.*

3461. *On a railway well constructed, and laid with a declivity of fifty-five feet in a mile, it is supposed that one horse will readily take down waggons containing from twelve to fifteen tons, and bring back the same waggons with four tons in them. This declivity, therefore, suits well, when the imports are only one-fourth part of what is to be exported. If the empty waggons only are to be brought back, the declivity may be made greater; or an additional horse applied on the returning journey will balance the increase of declivity. If the length of the railway were to be considered, it may, it is supposed, without much inconvenience, be varied from being level to a declivity of one inch in a yard, and by dividing the whole distance into separate stages, and providing the number of horses suitable for each portion of railway, according to the distance and degree of declivity, the whole operation may be carried on with regularity and despatch.*

3462. *Railways may be laid out so as to suit the surface of very irregular countries, at a comparatively moderate expense. A railway may be constructed in a much more expeditious manner than a navigable canal; it may be introduced into many districts where canals are wholly inapplicable; and in case of any change in the working of mines, pits, or manufactories, the rails may be taken up and laid down again in new situations, at no very great expense or trouble.*

3463. *The whole load to be drawn by one horse upon railways was at first put into one waggon; but now when the load is so much augmented, it has been found eligible to divide it into many parts, so that no one waggon shall carry more than one or two tons; by this method the weight is so divided, that the pressure is never so great upon one point as to be in danger of too much crushing the road; the carriages can be made much more limber and light in all their parts (fig. 443.), and they are much more easily moved and more manageable in all respects than they otherwise would have been. And another advantage of this arrangement, which deserves to be particularly adverted to, is, that it admits of shifting the carriages so as to leave a load, as it were, in parcels at different places where they may be required, without trouble or expense. This, when it comes to be fully understood and carried into practice, will be a convenience of inestimable value, a thing that has been always wanted, and never yet has been found, though it has been diligently sought for.*

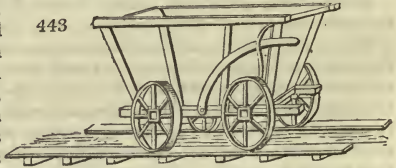

3464. *Of the advantage of railways a striking proof is given by Anderson, (Recreations, &c.) It was formed by Wilkes near Loughborough. Its extent was about five miles, and it led from a coal mine to a market. He found it so fully to answer his expectations after it was finished, that he communicated to the society of arts an account of some trials he had made of it, requesting that such of the members of that respectable institution as were desirous of information on that head, would do him the honor to witness some experiments that he wished to make upon it, for the information of the public. A committee of the members was accordingly deputed for that purpose, and before them he shewed that a moderate sized horse, of about twenty pounds value, could draw upon it with ease down hill (the descent being one foot in a hundred) thirty-two tons, and without much difficulty forty-three, and seven tons up hill, independent of the carriages. The doctor concludes from these facts, that upon a perfect level a horse could draw with ease from ten to twenty tons. It is observed, that Wilkes's railway, on which the experiments were made, was, from local circumstances, laid upon wooden sleepers, and is not so perfect as those done upon stone. But it is added, that twenty tons are the load which such a horse could draw with ease, travelling at the usual waggon rate, in boats upon a canal; so that the number of horses required in this way will not be much, if at all, greater than on a canal. Certain advantages attach to this mode of conveyance, which do not so well apply to a canal, and vice versa; but it is not his intention to draw a parallel between these two modes of conveyance. Nobody can entertain any doubt, he thinks, about the utility of canals where they are easily practicable. He only wishes to point out this as an eligible mode of conveyance where canals cannot be conveniently adopted.*

3465. *In forming and constructing railways, the best line the country affords should*



be traced out, having regard to the direction of the carriage of articles, or trade to be expected; and if such trade be both ways in nearly equal quantities, a line as nearly horizontally level as possible should be chosen. If the trade is all in one direction, as is generally the case between mines and navigation, then the most desirable line is one with a gentle gradual descent, such as shall make it not greater labor for the horses employed to draw the loaded waggons down, than the empty ones back; and this will be found to be the case on a railway descending about one foot vertical in one hundred feet horizontal. Or if the railway and carriages are of the very best construction, the descent vertical may be to the length horizontal, as 1 to 50, where there is little or no upgate loading. In cases between mines and navigations, the descents will often be found greater than could be wished. On a railway on the improved plan, where the descent is more than as 1 to 50, six or eight waggons, loaded with thirty or forty hundred weight each, will have such a tendency to run downwards, as would require great labor of one horse to check and regulate, unless that tendency was checked by sledging some of the wheels. On such, and steeper roads, iron slippers are applied, one or more to a gang of waggons, as occasion may require. Each slipper being chained to the side of one of the waggons, and, being put under the wheel, forms a sledge. Where the descent is very great, steep inclined planes, with machinery, may be adopted so as to render the other parts of the railway easy. On such inclined planes the descending loaded waggons being applied to raise the ascending empty, or partly loaded ones, the necessity of sledging the wheels is avoided; and the labor of the horse greatly reduced and lessened. (*Fulton.*)

3466. *In order to obtain the desired levels, gentle descents, or steep inclined planes, and to avoid sharp turns, and circuitous tracks, it will often be found prudent to cross valleys by bridges and embankments; to cut through ridges of land; and in very rugged countries short tunnels may sometimes be necessary. The line of railway being fixed, and the plans and sections by which the same is to be executed and settled; the ground for the whole must be formed and effectually drained. The breadth of the bed for a single railway should be, in general, four yards; and for a double one six yards, exclusive of the fences, side drains, and ramparts.*

3467. *The bed of road being so formed to the proper inclination, and the embankments and works thereof made firm, the surface must be covered with a bed of stones broken small, or good gravel, six inches in thickness or depth. On this bed must be laid the sleepers, or blocks to fasten the rails upon. These should be of stone in all places where it can be obtained in blocks of sufficient size. They should be not less than eight, nor more than twelve inches in thickness; and of such breadth (circular, square, or triangular,) as shall make them 150 lbs. or 200 lbs. weight each. Their shape is not material, so as they have a flat bottom to rest upon, and a small portion of their upper surface level, to form a firm bed for the end of the rails. In the centre of each block should be drilled a hole, an inch and a half diameter, and six inches in depth, to receive an octagonal plug of dry oak, five inches in length; for it should not reach the bottom of the hole; nor should it be larger than so as to put in easily, and without much driving; for if too tight fitted it might when wet burst the stone. These plugs are each to receive an iron spike or large nail, with a flat point and long head, adapted to fit the counter sunk notches in the ends of two rails, and thereby to fasten them down in the proper position, or situation in which they are to lie.*

3468. *With regard to the rails, they should be of the stoutest cast-iron, one yard in length each, formed with a flanch on the inner edge, about two inches and a half high at the ends, and three and a half in the centre; and shaped in the best manner to give strength to the rails, and keep the wheels in their track. The soles of the rails, for general purposes, should not, he thinks, be less than four inches broad; and the thickness proportioned to the work they are intended for. On railways for heavy burdens, great use, and long duration, the rails should be very stout, weighing 40 lbs., or in some cases, nearly half an hundred weight each. For railways of less consequence, less weight of metal will do; but it will not be prudent to use them of less than 30 lbs. weight each, in any situation exposed to breakage above ground. But it is observed that in mines, and other works under ground, where very small carriages only can be employed, very light rails are used, forming what are called tram-roads, on a system introduced by Carr; and these kinds of light railways have been much used above ground in Shropshire, and other counties where coals and other minerals are obtained.*

3469. *In fixing the blocks and rails, great attention is required to make them firm. No earth or soft materials should be used between the blocks and the bed of small stones or gravel, on which the rails must all be fixed by an iron gauge, to keep the sides at a regular distance, or parallel to each other. The best width of road for general purposes, is four feet two inches between the flanches of the rails; the wheels of the carriages running in tracks about four feet six inches asunder. Rails of particular*

forms are necessary where roads branch out from or intersect each other; and where carriage roads cross the railways; and, at turnings of the railways, great care is required to make them perfectly easy. The rails of the side forming the inner part of the curve should be fixed a little lower than the other; and the rails should be set a little under the gauge, so as to bring the sides nearer together than in the straight parts: these deviations in level and width to be in proportion to the sharpness of the curve. The blocks and rails being fixed and spiked fast, nothing more remains to be done than to fill the horse-path, or space between the blocks, with good gravel, or other proper materials; a little of which must also be put on the outside of the blocks to keep them in their proper places. This gravel should always be kept below the surface of the rails on which the wheels are to run, to keep the tracks of the wheels free from dirt and obstructions. The form of the rails must be such as will free them from dirt if the gravelling is kept below their level.

3470. *The formation of railways, on the middle or sides of public roads, has been recommended by Dr. Anderson, Fulton, Edgeworth, Middleton, and a few others. It does not appear to us, notwithstanding all the arguments in their favor, that they would be found of much use, excepting in a few cases, and then only for particular branches of traffick. Formed as they are for small waggons, in order to divide the weight, they would not bear with safety the weight of common farmers' two-horse carts; nor, unless the rails were of a particular construction, could such carts or any other now in or likely to be in general use, run on them. Suppose some alteration made on the wheels, to suit the rails, then such alteration would render the wheels unsuitable for common roads. In short, railroads, as constructed for ordinary purposes, could never be of much service to a great thoroughfare with a mixed traffick.*

3471. *A railway, with the rail ten or twelve inches broad, is the only description which we conceive might be laid down along the sides of a road with advantage. It would require a rib below of sufficient strength to bear waggons of any weight. This strength would be communicated partly by the mass of material, but chiefly by the rib (fig. 444 a), resting on a bed of bricks, or masonry below (b). Such a railroad might be used by any description of carriage, light or heavy.*

444

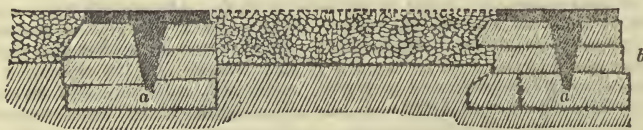

3472. *But the best description of railroad for the sides of a highway, appears to us to be one formed of blocks of granite twelve or fourteen inches wide, and two or three feet long, imbedded on brick or masonry, or even on a layer of gravel or broken stones. Stone railways of this sort appear to have been suggested by Le Large (*Machines Approuvées*, vol. iii.) in France; and afterwards by Mathews (*Committee Examinations*, May 1808,) in England, but they have never been fairly tried. The best specimen we have seen is in a street in Milan, where it is not so necessary, the whole breadth being very well paved.*

#### SECT. VI. *Of the Preservation and Repair of Roads.*

3473. *The preservation of a road depends in a great measure on the description of machines and animals which pass over it, and on keeping it dry and free from dust and mud. The repair of a road should commence immediately after it is finished, and consists in obliterating ruts the moment they appear, filling up any hollows, breaking any loose stones, and correcting any other defect. After cleaning and this sort of repair have gone on hand in hand for a longer or shorter period, according to the nature of the materials and traffick of the road, a thorough repair or surface-renewal may be wanted by a coating of metal of three or more inches in thickness over the whole of the road.*

3474. *To preserve a road by improving the wheel carriages which pass over it, all agree that the wheels should be made broader than they usually are, and cylindrical; that carts with two horses abreast are less injurious, than such as are drawn by two horses in a line; and that it would be an advantage to have the axletrees of different lengths.*

3475. *Edgeworth, upon a careful examination, concludes, that the system of rolling roads by very broad wheels should be abandoned; and that such a breadth only should be insisted upon, and such restrictions made as to loading, as will prevent the materials of the road from being ground to powder, or from being cut into ruts. With this view the wheels of carriages of burden should have felloes six inches broad, and no more than one ton should be carried upon each wheel.*

3476. *Farey* is of opinion, that six inch cylindrical wheels, or under, are the most practicable and useful, provided the projecting nails are most rigidly prohibited, which can never be done but by a penalty per nail upon the wheelers who put in those nails, and upon the drivers of the carriages who use such roughly-nailed wheels.

3477. *Telford* thinks that no waggon or cart wheel ought to be of less breadth than four inches, and that in general no carriage ought to be allowed to carry more than at the rate of one ton per wheel: "when it exceeds that weight," he says, "the best materials which can be procured for road-making, must be deranged and ground to pieces."

3478. *Paterson* is a warm advocate for broad wheels. "If the wheels were used double the breadth as at present," he says, "they would act as rollers upon the materials, binding them together, and consequently the surface would remain always smooth and free from ruts; and the waste or decay would, of course, be exceedingly little. All broad wheels, however, should be made on a construction different from those that are in common use (fig. 445 a.). Those in common use,

whether broad or narrow, are generally *dished* (as it is called) on the outside, and the ends of the axletree bent a little downwards. This causes the wheels to run wider above than below; and the reason, I believe, for adopting this plan was to allow people to increase the breadth of their carriages, and yet the wheels to run in the same track. Upon this plan, the edges of the wheel, to run flat upon the road, must be of a *conical* shape, the outer edge being of a less diameter than the inner one. Any bad effect arising from this is indeed very little felt from the narrow wheels; but as they increase in breadth, the evil increases in the same proportion.

"A conical wheel," says *Edgeworth*, "if moved forwards by the axletree, must partly roll and partly slide on the ground, for the smaller circumference could not advance in one revolution as far as the larger. Suppose," says he, "the larger revolution sixteen feet, and the smaller thirteen feet, the outer part must slide three feet, while the carriage advances sixteen, *i. e.* it must slide nearly one-fifth of the space through which the carriage advances,—thus, if loaded with ten tons, the horses would have two tons to drag, as if that part of the weight was placed on a sledge." The same thing has been ably and beautifully demonstrated by *Cumming* (*Essay on the Principles of Wheels and Wheel Carriages, &c.*), and is very easily illustrated; take, for instance, the *frustum* of a cone, or a sugar loaf from which you have broken off a little bit at the point; then set this a rolling upon a table, and instead of going straight forwards it will describe a circle; and if you will put a pin or axletree right through the centre of it, and upon that axle cause it to move straight forwards, the smaller diameter must slide instead of rolling. It is evident, therefore, that the rims of the wheels ought to be of a *cylindrical* form (b). *Edgeworth* states, in relation to this, that "from the testimony given to the committee of parliament, by every person of science and judgment, cylindrical wheels and straight axletrees have been unequivocally preferred.

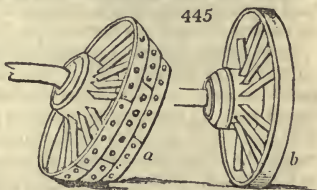

3479. *Farey* finds the Whitechapel road more injured by broad wheels than any other, owing to these wheels being barrelled and conical, and not running flat, and the middle tier projecting above the others with rough nails.

3480. *Cumming* has proved experimentally before the committee of 1808, that when the rim of a wheel is made truly cylindrical, so as to have an equal bearing on its whole breadth, the resistance to its progress on a smooth road is not increased by increasing its breadth. And in regard to the immense saving that would accrue to the nation, *Jessop*, in his report, says, "I may venture to assert, that by the exclusive adoption of cylindrical broad wheels and flat roads, there would be a saving of one horse in four, of seventy-five per cent. in repairs of roads, fifty per cent. in the wear of tire, and that the wheels with spokes alternately inclined, would be equally strong with conical ones, and wear twice as long as wheels do now on the present roads." But, over and above the preference due to such wheels, in respect to public roads, they are no less preferable when applied to purposes of husbandry. Besides the great resistance to the draught occasioned by the sinking of the narrow wheels on soft land, every farmer knows what injury is frequently done to subsequent crops by such poaching and cutting up of the land. But this is not all. Many a field of beautiful pasture, when subjected to the destroying operation of the narrow wheels, is very much injured, both in respect to the appearance and the crop, which would be entirely prevented by using broad wheels. Thus it has been stated, in regard to the introduction of the use of broad wheels, that the saving on the incidental repairs of the road would be immense; that the roads would uniformly retain a smooth and even surface, which would greatly contribute to the comfort of the traveller, and the ease of the draught; that in husbandry also the advantages would be great; in short, that in every point of view, the benefits that would be derived in consequence,

would be paramount to every thing that could be urged in favor of the narrow wheels.

3481. *M<sup>r</sup> Adam* thinks a waggon wheel of six inches in breadth, if standing fairly on the road with any weight whatever, would do very little material injury to a road well made, and perfectly smooth. The injury done to roads is by these immense weights striking against materials, and in the present mode of shaping the wheels they drive the materials before them, instead of passing over them. If a carriage passes fairly over a smooth surface, he says, that cannot hurt the road, but must rather be an advantage to it, upon the principle of the roller. On being asked, "Are you not of opinion that the immense weights carried by the broad-wheeled waggons, even by their perpendicular pressure, do injury by crushing the materials?" he answered, "On a new-made road the crush would do mischief, but on a consolidated old road, the mere perpendicular pressure does not do any. But there is a great deal of injury done by the conical form of the broad wheels, which operate like sledging instead of turning fairly. There is a sixteen-inch wheel waggon, which comes out of Bristol, that does more injury to our roads, than all the travelling of the day besides."

3482. With regard to *regulating the weight to be carried on wheels*, *Farey* judiciously observes, that though it is not easy to state any one scale that would be generally applicable for each breadth of wheels below six inches, there should be a rate fixed, which would apply to ordinary or gate-tolls; and at the weighing machines additional or what may be called machine tolls, should be levied upon all carriages which exceeded the weight, to be regulated in an increasing scale for each breadth of wheel, so as very greatly to discourage, but not ruinously to prohibit the occasional carrying of large weights upon any wheels.

3483. *Axletrees of different lengths* have been proposed by some engineers with a view of preserving the roads. On this subject *Paterson* observes, "At present the axles of all kinds of carriages are made to one length, so that their wheels all run at the same width, and in the same track, than which nothing could be more fitly devised for the destruction of the roads. I would, therefore, propose, that the length of the axletrees should be so varied, that the wheels of the lighter description of carriages should run two inches narrower than the present track; and that the axles for the more weighty carriages should be increased in length, so that their wheels should run from one to four inches beyond the present track. I would also propose, that mails, and other heavy coaches, should be so constructed, that the hind wheels should follow, either two inches within, or two inches outside the track of the fore-wheels, as might be considered most proper. Were the axletrees of all kinds of carriages to be of various lengths, as here proposed, we should have no rutted roads. The stones now displaced by the wheels of one carriage, would be replaced again by the next carriage that came up, having its axle of a different length; and in the same manner would the hind wheels repair the injury done by the fore wheels of a carriage. If this plan was to be acted upon all over the kingdom, it is evident that it would have a very beneficial effect on the roads; and if it should be found thus to contribute to the keeping the roads smooth and even, it is also evident that it must contribute, in the same proportion, to the comfort of travellers of every description, and also to the ease of the beast of draught."

3484. *J. Farey* is of opinion that varying the length of axles, so as to prevent their running in the same track, would be very beneficial. This he particularly stated to the Board of Agriculture, with an example of the tolls over a new road in Derbyshire, which are regulated according to the length of the axle.

3485. *The division of weight* has been proposed by *Fry* as a means of preserving roads: that is to say, the division of the power, which any carriage may possess, to crush or destroy the materials of the roads; and the division of the power which any carriage may possess, to resist the power of the horses drawing such carriage. A man can break an ordinary stick, an inch in diameter, across his knee, but if he tie ten of these sticks together, he could not break them if he tried ten times, nor if he tried a thousand times; although, by these thousand efforts, he might have broken a thousand such sticks separately. A stone might be of such a size and texture that a strong man with a large hammer might break it into pieces at one blow; while a boy with a small hammer, striking it with one-tenth part of the force, might strike it a thousand times, applying in the whole one hundred times the power upon it that the man would have done, without producing the same effect. So it is with the pressure of wheels on the materials of the roads. Suppose a stone, the size of a man's fist, to be detached on a firm part of the road, and a waggon-wheel, pressing with the weight of two tons, were to pass over it, the consequence would be that it would crush it to powder. But suppose these two tons to be distributed into forty wheel-barrows, of one hundred weight each, and they were to pass over it in succession, the only effect likely to be produced would be a trifling rounding of its corners: nor would probably five hundred such wheel-barrows, of twenty-five tons, crush the stone so completely as the single waggon-wheel. Nor do I

think that five hundred gig or one-horse chaise wheels, of four hundred weight each, in all one hundred tons, would so completely destroy the cohesion of the stone, as the single crush of the heavy wheel. Conceiving, therefore, that the destructive effect of pressure on the roads increases, from the lowest weights to the highest, in a very rapidly increasing ratio, I think that all reasonable ingenuity should be exercised, so as to construct our carriages as for each wheel to press the road with the least possible weight that the public convenience will allow."

3486. *A great weight in one rolling mass* (fig. 446.), Fry continues, "has a tendency



446

to disturb the entire bed of the road, whether it be on a six-inch wheel or on one of sixteen inches, and whether on conical (fig. 445 a) or on cylindrical wheels (fig. 445 b): Under all these considerations, I am satisfied that the only grand desideratum on behalf both of the roads and the horses, is light pressure. And therefore any dependence on breadth of wheels, as a security against the destructive effects of pressure, is in my opinion fallacious. I wish here to be understood as applying these remarks upon a supposition that wheels were made upon the most philosophical construction; that is to say, perfectly cylindrical (fig. 445 b); and that they stood perfectly upright or vertical. The present system of broad wheels I consider a system of mere mockery."

3487. *Fry proposes to attain his principle of the division of power* by the adoption of light one-horse waggons with six or eight wheels; which in our opinion are of very questionable advantage, all things considered, compared to one-horse carts, to carry one ton, and four-wheel waggons to carry four tons. One-horse waggons, he says, fully embrace the principle; and the labor of the horses would be much more efficiently applied than at present. If light one-horse waggons were constructed, to weigh eight hundred weight each, and these were charged with a load of sixteen hundred weight each, a good ordinary cart-horse would travel England over with such a load; drawing just as much net weight as the ten horses in a heavy waggon, take each in gross weight; and the roads would never have a pressure, on one point, exceeding six hundred weight. The only objection to such carriages that I see is, that each must be attended by a man. But were they adopted, roads would last, I will not say ten times as long, I think they would last a hundred times as long as they now do. Carriages so constructed ought therefore to pass at the lowest possible rate of toll. The next mode is by the use of carriages with six or eight wheels. About twenty years ago there were several stage-coaches constructed in this manner. Two eight-wheel coaches plied some years between Bath and Bristol, and they were so constructed that each wheel supported its share of the load, carrying its proportion, and no more, over every obstruction: the consequence was, that when a wheel passed over a stone two inches high, the middle part of the carriage rising only an eighth part of two inches, or one quarter of an inch, they were perhaps the easiest coaches to passengers that ever were sat in. They had, however, one defect in their construction: which was, that the two hinder axles being fixed, whenever the coach varied from a straight line on the road, the hindermost pair of wheels must have been dragged sideways. How the six-wheel coaches were circumstanced in this respect, I had no opportunity of observing.

3488. *Double shafts* have been proposed by Edgeworth, Morton, and some others, as likely to divide the traction of draught cattle. B. Farey considers single shafts in waggons very injurious; the horses follow in one track, in the centre of the carriage; and the wheels also follow each other in their tracks, and cut ruts. If there were double shafts, they would naturally avoid former wheel tracks, which would be less injurious to the road.

3489. *J. Farey* concurs in opinion with his brother, and thinks that some abatement of tolls might be made to those carriages which now generally use single shafts, like the farmers' carts and waggons, on their adopting double shafts, so that all their horses may draw in pairs; this being applicable even to three-horse carts, as far as concerns the two foremost. Stage-coaches, for the reasons here alluded to, as they all draw in pairs, and very seldom follow in any previous and deep rut, do far less damage to the roads than otherwise would happen; their springs also, and swiftness of motion, contributing, very materially, to lessening their wear of the road.

3490. *The cleaning of roads* is effected by sweeping, scraping, watering, and washing.

3491. *Sweeping*, as a mode of cleaning roads, is chiefly applicable to pavements, to side railways, whether of stone or iron, and to footpaths. It has been proposed to be effected by a machine drawn by one or more horses early in the morning before the road was much frequented; but it is probably better to leave it to old and infirm persons. On country roads, sweeping could only be required to keep the paved or rail-laid part, where such existed, free from small stones or gravel which the feet of cattle, &c. might scatter over it from the metalled part.

3492. *Scraping* is an operation universally necessary to keep roads clean, by the removal of mud in wet weather, and dust in a very dry season, and snow in winter. It has been performed by machinery; and on a well-made road, this mode might be attended with a considerable saving of labor. Were the scraping board edged with a brush of wires, or even of birch spray, the work even on a road somewhat irregular, might be done to great perfection. Both in scraping and sweeping, care should be taken as soon as possible to dispose of the mud or dust either in making or keeping up the sides of the road or fence mounds, or in such other way as circumstances may direct. Hand scrapers are commonly made with iron plates; but a piece of board is considered less likely to raise the surface of the road.

3493. *Watering*, where applied to roads, is more for the sake of laying the dust than cleaning or preserving. Some consider it injurious in the latter capacity. B. Farey considers that watering the Whitechapel-road in summer, and especially before May and after August, is very injurious, by separating the stones, owing to the softening of the loam, and so making the road spongy and loose. In winter, however, he waters, and for the following reasons: — “After the most careful sifting of the gravel, a small quantity of loamy dirt will unavoidably still adhere to the stones, and this loam, together with a glutinous matter which accumulates in the summer from the dung and urine of the cattle (which accumulation the summer-watering has a tendency to increase), occasions the wheels to stick to the materials, in certain states of the road, in spring and autumn, when it is between wet and dry; particularly in heavy foggy weather, and after a frost; by which sticking of the wheels, the Whitechapel-road is often, in a short time, dreadfully torn and loosened up; and it is for remedying this evil that I have, for more than eight years past, occasionally watered the road in winter. As soon as the sticking and tearing up of the materials is observed to have commenced, several water-carts are employed upon these parts of the road, to wet the loamy and glutinous matters so much, that they will no longer adhere to the tire of the wheels, and to allow the wheels and feet of the horses to force down and again fasten the gravel-stones; the traffick, in the course of four to twenty-four hours after watering, forms such a sludge on the surface, as can be easily raked off by wooden scrapers, which is performed as quickly as possible; after which the road is hard and smooth; the advantages of this practice of occasional winter-watering have been great; and it might, I am of opinion, be adopted with like advantages on the other entrances into London, or wherever else the traffick is great, and the gravel-stones are at times observed to be torn up by the sticking of the wheels.

3494. *One of the best construction of watering barrels* (fig. 447.), is that used on the Uxbridge-road, in which the water is delivered with the greatest regularity from a cast-

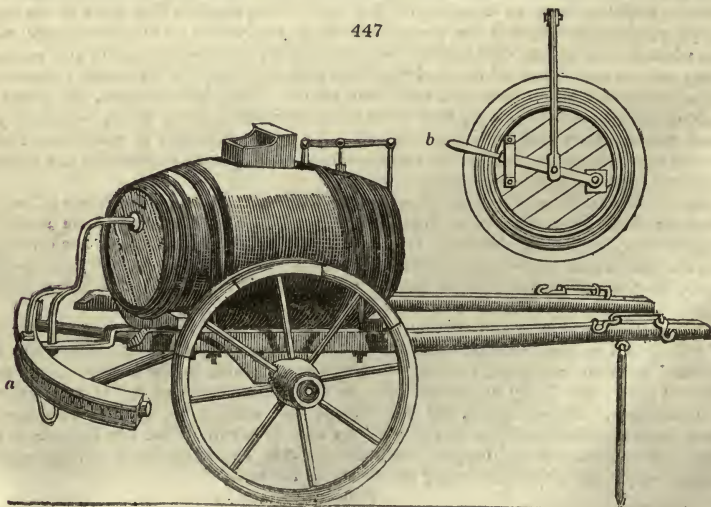

iron trough (a), so as to cover a space of nine feet in width. The water is turned off and on by a lever at the fore-end of the barrel (b) in the usual manner.

3495. *Washing or flooding roads* with a view to cleaning them, has been proposed by Jessop, and some other engineers; but it is evidently a mode that can only be adopted in particular situations, and the advantages which it would have over clean scraping does not appear.

3496. *Rolling*, as a mode of preserving roads, is recommended by various writers on the subject; and appears to be useful on some roads after being loosened by frost. In general, however, it is chiefly applicable after repairs, such as filling in ruts or laying on a coat of new materials. Rolling has also been employed to consolidate snow on roads: it is said to indurate the snow so much, that it becomes a smooth hard body, on which the wheels of carriages make but little impression, and the materials of the road are preserved. When a thaw happens, the whole of the snow is scraped off by snow-ploughs or scrapers, and not being allowed to melt on the metals, they are said to remain unloosened. This plan is said to be general in America, and appears to have been tried, in one instance, in the north of Scotland, with success.

3497. *A road-roller* should be of large diameter, perhaps not less than five feet: to facilitate its turning, it may be made in three lengths, and the only material is cast-iron, with a large wooden box over.

3498. *Marshal*, on the subject of repairing roads, observes, that the best service of the surveyor is to keep their surfaces smooth and even; so that rain-water may find a free and ready passage to its proper drain. Ruts and hollow parts are to be filled up, level, or even with the general surface, as often as they are formed. This attention is more especially requisite to a new-made road, whose bed and foundation are not yet fully confirmed. But in every case, and at all times, a solicitous regard is due to this most important, yet most neglected part of road-surveying. Much expense of materials and labor may thereby be saved, and the great end of road-making be fully obtained; namely, that of rendering the road, in all seasons, easy, safe, and pleasant to the traveller.

3499. *To keep a road in repair*, Edgeworth observes, it will for some time require the attention of the maker; ruts will be continually formed in the loose materials: these must be sedulously filled up, and a small sprinkling of river gravel should be added. All stones larger than the rest should be removed and broken smaller, and no pains should be spared to render the whole as compact and smooth as possible. At a moderate distance from the capital, if no wheels of a smaller breadth than six inches, and if no greater load than one ton on each wheel be permitted to pass on it, a road will last a long time, and may be kept in constant repair, at a moderate yearly expense.

3500. *The repair of a road* which has been well made, or put into a good state of repair, Paterson observes, requires attention more than expense. "No more metals ought to be used for the incidental repair of that road ever afterwards than is just equivalent to the decay of the road. And in order that the decay of the old, and of course the supply of new metals may be as little as possible, it is of the greatest consequence that the road never be allowed to get rutted; for, besides the unpleasantness of such a road to the traveller, it is a fact not generally thought upon, that the lateral rubbing of the wheels into the ruts will wear and grind down more than the double of the metals than if the road were smooth, and where the only friction of the wheels is that of rolling over the metals. Besides, when a road is much rutted, it not only retains the water, and consumes a greater quantity of metals (as hath been noticed); but the rubbing and jolting of the wheels into the ruts wears down the iron of the wheels, fatigues the beast of draught, and also wears harness, &c. much sooner than when the road is smooth. All these, and much more, are the bad effects of a rutted road. Having premised thus much I shall next advert to the method to be adopted in order to keep the road free from ruts, at as little expense and labor, and with as few metals as possible.

3501. *In order to prevent any road from getting rutted*, it is indispensable that it be kept free from water by under drainage. No road, Paterson continues, that has any tendency to rut should be, for many days together, from under the eye of one who has a general charge, and who is ready to withdraw a workman to this or that part, as need may require.

3502. *So soon as newly-put-on metals begin to shift by the wheels*, or form into ruts, they should be immediately replaced, every little ridge broken down, and every rut, hole, or inequality, filled up; and the road kept in proper shape until the metals become bound and consolidated together. When the road is attended to in this manner, it has the effect too, of subjecting the whole of the metals to an equal fatigue. Every time that a little new metals are put on to fill up any hollow parts of the road, those parts being then, from the new metals, a little rougher than the rest of the road, the horses naturally avoid travelling on them for a while at first, until they have become a little smoother, or until the other parts begin to get rutted. This shifting upon the road wears down the metals equally, and prevents those regular tracks of the horse and of the wheels which would otherwise be the consequence. By adopting this method, it will be found that less labor and fewer metals will be required in the course of the year, and the road will always be in good order. But, on the other hand, to allow the road to get rutted, and then to fill these ruts with new metals every time they get into this state, as is frequently done, raises the track of the wheels, leaving hollow the track of the horse, and so gives the road a concave, instead of a convex, shape in the middle: this retains the water, and injures the road very much. The same thing occurs again

and the same process is repeated; and in this way the most extravagant quantity of metals may be put on, and yet never have the road in good order.

3503. *For the repair of an old road*, the following directions are given by M<sup>r</sup> Adam, in his *Report to the Committee, &c.* of 1811, corrected however to 1819. "No addition of materials is to be brought upon a road, unless in any part it be found that there is not a quantity of clean stone equal to ten inches in thickness.

3504. *The stone already on the road* is to be loosened up and broken, so as no piece shall exceed six ounces in weight. The road is then to be laid as flat as possible; a rise of three inches from the centre to the side is sufficient for a road thirty feet wide. The stones, when loosened in the road, are to be gathered off by means of a strong heavy rake, with teeth two and a half inches in length, to the side of the road, and there broken, and on no account are stones to be broken on the road.

3505. *When the great stones have been removed*, and none left in the road exceeding six ounces, the road is to be put in shape, and a rake employed to smooth the surface, which will at the same time bring to the surface the remaining stone, and will allow the dirt to go down.

3506. *When the road is so prepared*, the stone that has been broken by the side of the road is then to be carefully spread on it: this is rather a nice operation, and the future quality of the road will greatly depend on the manner in which it is performed. The stone must not be laid on in shovelfull, but scattered over the surface, one shovelfull following another, and spreading over a considerable space.

3507. *Only a small space of road should be lifted at once*; five men in a gang should be set to lift it all across; two men should continue to pick up and rake off the large stones and to form the road for receiving the broken stone; the other three should break stones; the broken stone to be laid on as soon as the piece of road is prepared to receive it, and then break up another piece; two or three yards at one lift is enough.

3508. *The proportioning the work among the five men* must of course be regulated by the nature of the road; when there are many very large stones, the three breakers may not be able to keep pace with the two men employed in lifting and forming, and when there are few large stones the contrary may be the case; of all this the surveyor must judge and direct.

3509. *But to lift and relay a road*, even if the materials should have been originally too large, would in many cases be highly unprofitable. The road between Cirencester and Bath is made of stone too large in size, but it is of so friable a nature that in lifting it becomes sand; in this case I recommended cutting down the high places, keeping the surface smooth and gradually wearing out the materials now in the road, and then replacing them with some stone of a better quality properly prepared.

3510. *A part of the road in the Bath district* is in like manner made of freestone, which it would be unprofitable to lift.

3511. *At Egham in Surrey*, it was necessary to remove the whole road, to separate the small portion of valuable materials from the mass of soft matter of which it was principally composed, which was removed at considerable expense, before a road could be again made upon the site.

3512. *Other cases of several kinds* have occurred where a different method must be adopted, but which it is impossible to specify, and must be met by the practical skill of the officer whose duty it may be to superintend the repair of a road, and who must constantly recur to general principles. These principles are uniform, however much circumstances may differ, and they must form the guide by which his judgment must be always directed.

3513. *When additional stone is wanted on a road* that has consolidated by use, the old hardened surface of the road is to be loosened with a pick, in order to make the fresh materials unite with the old.

3514. *Ruts*. Carriages, whatever be the construction of their wheels, will make ruts in a new-made road until it consolidates, however well the materials may be prepared, or however judiciously applied; therefore a careful person must attend for some time after the road is opened for use, to rake in the tracks made by wheels.

3515. *The tools to be used are*: strong picks, but short from the handle to the point, for lifting the road; small hammers of about one pound weight in the head, the face the size of a new shilling, well steeled, with a short handle; rakes with wooden heads, ten inches in length, and iron teeth about two inches and a half in length, very strong for raking out the large stones where the road is broken up, and for keeping the road smooth after being relaid, and while it is consolidating; very light broad-mouthed shovels, to spread the broken stone and to form the road.

3516. *Every road is to be made of broken stone without mixture of earth, clay, chalk*, or any other matter that will imbibe water, and be affected with frost: nothing is to be laid on the clean stone on pretence of binding; broken stone will combine by its acute angles



into a smooth solid surface that cannot be affected by vicissitudes of weather, or displaced by the action of wheels, which will pass over it without a jolt, and consequently without injury."

3517. *Telford's directions for repairing roads* differ little from his instructions for forming roads, already quoted. Where a road

448

has no solid and dry foundation, he bottoms with soft stones or cinders, the former set by hand with the broadest end down, in the form of a neat pavement (fig. 448.); over this foundation he, as usual, lays on six inches of stones broken so as to pass through a ring, two inches and a half in diameter, &c.

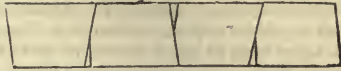

3518. *Where a road has some foundation*, but an imperfect one, or is hollow in the middle, all the large stones appearing on the surface of it must be raised and broken; the eighteen centre feet of it must be so treated, and then covered with a coating of broken stones, sufficient to give it a proper shape, and to make it solid and hard.

3519. *Where a road already has a good foundation*, and also a good shape, no materials should be laid upon it but for the purpose of filling ruts and hollow places, in thin layers as soon as they appear. Stones broken small, as above described, being angular, will fasten together. In this way a road when once well made, may be preserved in constant repair at a small expense.

3520. *Partial metalling.* Where the breadth of that part of a road, which alone has been formed of hard materials, and over which the carriages commonly pass, is less than eighteen feet, it must be widened with layers of broken stones to that breadth, first digging away the earth, and forming a bed for them with pavement and broken stones, at least ten inches deep. Near large towns the whole breadth of the road-way should be covered with broken stones.

3521. *All labor by day wages* ought, as far as possible, to be discontinued in repairing roads. The surveyors should make out specifications of the work of every kind that is to be performed in a given time. This should be let to contractors, and the surveyors should take care to see it completed according to the specifications, before it is paid for. Attention to this rule is most essential, as in many cases not less than two-thirds of the money usually expended by day labor is wasted.

3522. *The best seasons for repairing roads* is generally considered autumn and spring, when the weather is moist rather than otherwise. B. Farey prefers laying on gravel when the road is in a moist state, immediately after the road has had a scraping, in consequence of there being upon the surface of the road a small quantity of dirty matter and broken gravel, which then forms a sort of cement for the gravel to fix in.

3523. Walker considers the *best season for repairing roads*, to be the spring or very early in the summer, when the weather is likely neither to be very wet nor dry, for both of these extremes prevent the materials from consolidating, and therefore cause a waste of them, and at the same time either a heavy or a dusty road; but if done at the time he has recommended, the roads are left in good state for the summer, and become consolidated and hard to resist the work of the ensuing winter.

3524. *The seasons for repairing preferred by Paterson* are also spring and autumn. "Although it is proper," he says, "at all times of the year, to put on a little metals whenever any hole makes its appearance, yet in the drought of summer this will seldom be necessary. In summer, the roads are less liable to cut; but if, at some places, a little fresh metals may be necessary, no more should be put on than is barely sufficient to bring those holes to the level of the rest of the road. Metals that are put on in the drought of summer do not soon bind together. Until such time as there is rain sufficient to cause them to bind, they will keep shifting and rolling about, and make a very unpleasant road to travel on. The most proper times of the year to put on any quantity of metals are about the months of October and April, as they always bind best when the road is neither too wet nor too dry. When they are put on about the month of October they become firm before winter; and, with a little constant attention, the road will be easily kept in good order until the spring: and if it has been the case that the road has not been sufficiently attended to during the winter, and that it has got into a bad state towards the spring, by putting on fresh metals about the month of April, sufficient to bring it into smooth surface order, it will be very easily kept in this good state throughout the summer."

3525. *M. Adam*, on being asked, "Would you prefer repairing old roads in dry weather or in wet weather?" answers: "In wet weather always; I always prefer mending a road in weather not very dry."

## CHAP. V.

*Of the Formation of Canals.*

3526. *Though the subject of canals is not included in that of agriculture, yet it is so intimately connected with territorial improvement, that it would be improper in a work of this description to pass it over.* Canals of any extent are never the work of an individual, but of public bodies, constituted and empowered by public acts; but it is of importance to individuals to know the sort of effect which a canal passing through their property may have, both on its appearance and value; not merely as a medium of conveyance, but as a source of population, of water for irrigation or mills, or the use of stock, and even as an object of ornament. For this purpose we shall submit some remarks on the utility of canals, the choice of lines, the powers granted to canal companies, and the mode of execution.

SECT. I. *Utility of Navigable Canals.*

3527. *Good roads, canals, and navigable rivers,* Dr. Smith observes (*Wealth of Nations*, i. 229), by diminishing the expense of carriage, put the remote parts of the country more nearly upon a level with those in the neighborhood of large towns; and on that account they are the greatest of all improvements. They encourage the cultivation of the remote parts, which must always be the most extensive circle of the country. They are advantageous to towns, by breaking down the monopoly of the country in its neighborhood, and they are advantageous to all parts of the country; for though they introduce some rival commodities into the old markets, they open many new markets to its produce. "All canals," says an intelligent writer on this subject (*See Phillips's General History of Inland Navigation, Introd.*) "may be considered as so many roads of a certain kind, on which one horse will draw as much as thirty horses on ordinary turnpike roads, or on which one man alone will transport as many goods as three men and eighteen horses usually do on common roads. The public would be great gainers were they to lay out upon the making of every mile of a canal twenty times as much as they expend upon a mile of turnpike road; but a mile of canal is often made at a less expense than the mile of turnpike; consequently there is a great inducement to multiply the number of canals."

3528. *General arguments in favor of canals* are superseded by the rapidly improving and thriving state of the several cities, towns, and villages, and the agriculture also near to most of the canals of the kingdom, the immense number of mines of coal, iron, limestone, &c. and great works of every kind to which they have been conducted, and to which a large portion of them owe their rise, are their best recommendation. In short, it may be concluded, that no canal can be completed and brought into use, but the inhabitants and the agriculture of the district will shortly feel great benefit from it, whatever may be the result to the proprietors.

3529. *The great advantages of canals as means of transport* results from the weight which may be moved along by a small power. The velocity with which boats can be drawn along a canal is confined within very narrow limits, owing, as Edgeworth has observed, to the nature of the resistance to which they are exposed; this resistance increasing in a geometrical proportion, as the squares of the velocity with which the moving body is impelled. Whereas on roads or railways, an increase of velocity requires only an arithmetical increase of power; or, in other words, to draw a boat with ten times a given velocity, would require a hundred times as much power as was requisite to draw it with that given velocity. Whereas, to draw a carriage on a road or railway with ten times a given velocity, would require only ten times the given power. For this reason, however advantageous canals may have been found, for transporting heavy loads, they will be found upon trial inferior to roads in promoting expedition.

3530. *Canals appear to have been first made in Egypt.* Though less attended to by the Romans than roads, yet they formed some in this country near Lincoln and Peterborough. China is remarkable for its canals, and there are many in Hindostan. In Russia there are some and especially in Sweden; one or two in Denmark; some in Germany, and a great many in Holland. The canal of Burgundy in France was commenced under Henry IV. and that of Languedoc finished by Riquet, the Brindley of France, under Louis XIV. Some attempts have been made to form canals in the hilly country of Spain, and a great many excellent ones are executed in America.

3531. *Navigable canals in Britain* took their rise between 1755 and 1760, by the Sankey Brook Company in Lancashire; but the great impulse was given by the duke of Bridgewater about 1757; when he first commenced, under the direction of Brindley, the canal between his coal-works at Worsley and Salford. The duke of Bridgewater has, in consequence, not improperly been called the father of canals in England; while his engineer, Brindley, by his masterly performances on the duke of Bridgewater's canal, altered and extended as the scheme thereof was by the three subsequent acts of parlia-

ment, has secured to himself, and will it should seem (from a comparison of the great features, and minutæ of execution in this the first canal, with most others in this country, even of the latest construction,) long continue to hold that rank among the English engineers, to which Riquet seems entitled among foreigners.

3532. *Since the duke of Bridgewater's time* the extension of canals in the British isles has been rapid. A number of scientific engineers have arisen, of whom we need only mention Smeaton, Rennie, and Telford, and point to the Caledonian canal.

SECT. II. *Of discovering the most eligible Rout for a Line of Canal.*

3533. *The first object when the idea of a canal is determined* on by a few landed proprietors, is the choice of a skilful and experienced engineer. Such an artist should undoubtedly possess a considerable degree of mathematical knowledge. Calculations, of which some are of the most abstruse and laborious kind, will frequently occur; and he should, therefore, be well acquainted with the principles on which all calculations are founded, and by which they are to be rightly applied in practice. An engineer should also have studied the elements of most or all of the sciences immediately connected with his profession; and he should particularly excel in an acquaintance with the various branches of mechanics, both theoretical and practical. His knowledge should comprehend whatever has been written or done by other engineers, and he should have information in every department of his office, from an accurate examination of the most considerable works that have been executed in all the various circumstances that are likely to occur. It is necessary that he should be a ready and correct, if not a finished, draughtsman. He should also be conversant with the general principles of trade and commerce; with the various operations and improvements in agriculture; with the interests and connection of the different owners and occupiers of land, houses, mills, &c.; and with all the general laws and decisions of courts, pertaining to the objects connected with his profession. By an extensive acquaintance with the disposition, inclination, and thickness of the various strata of matter which compose the soil or land of the British islands, he will be able to avoid many errors incident to those who are destitute of this knowledge. As the last, though not the least, of these qualifications of an engineer, which we shall enumerate, he should be a man of strict integrity.

3534. *A proper engineer being fixed upon*, the adventurers should not tie him down too closely, by restrictions as to time, but allow him leisure to consider, digest, and revise again and again, the different projects and ways, which will naturally in most instances present themselves to him in an extensive and thorough investigation. The engineer should be allowed to choose and employ the most competent assistants, and to call in and occasionally to consult the opinions of eminent or practical men, as land-surveyors, agents of the neighboring landed property, the principal and most expert commercial men of the district and who are best acquainted with its trade and wants, any eminent miners, &c. &c.; and such men the engineer should be authorised liberally, and at once to remunerate for their services and intelligence. Previous to the beginning of any minute survey or system of levelling, the engineer ought to visit personally, and endeavour to make a just estimate, and preserve memorandums of all the objects within the district under consideration; as of the trade and importance of all the towns likely to be affected by the undertaking; of all mines of coal, iron, &c.; quarries of limestone, freestone, slate, &c.; or the situation where such can be found; of all the manufactories of heavy and cumbrous goods, and other extensive works; and generally of every thing likely to furnish tonnage for a canal. The most eligible rout for a canal being settled in the engineer's mind, he will then proceed to make a rough calculation of the quantity of goods of each different kind which may be expected to pass upon the line in a given time; he will also examine all the canals and rivers which the proposed canal is to connect with, and ascertain the widths and depths thereof, the sizes of their locks, and of the vessels usually navigating them.

3535. *The dimensions, number, and kind of locks* or inclined planes, length of levels, &c. may now be determined on, and how far railways or branch canals or roads may be connected with the main line. Many engineers, and especially Fulton, have warmly advocated the formation of small canals. On this subject, Chapman, a most judicious artist observes, "that the system of small canals is particularly eligible in all countries where limestone, coal, iron ore, lead, and other ponderous articles, not liable to damage from being wet, or likely to be stolen, are the objects chiefly to be attended to; and where the declivity of the country runs transversely to the course of the canal, which will generally be the case along the side of mountains, at an elevation above the regular ground at their feet. In those situations, the great falls or inclined planes may be made at the forks of rivers, so that the upper levels may branch up both the vales, and thus give the most extended communication. A situation suited for those canals will often

be found in countries that are not absolutely mountainous, but where the ground regularly declines towards the vales or large rivers."

3536. *A rough section of the proposed line* will enable the engineer to see the places of the heights and breadths of the various summits, or ranges of high land that are to be passed, and whether any two or more adjacent ones can be connected by a long summit level, without deserting any considerable town or point of trade, which will diminish the difficulties of supplying the canal with water, as every such junction of summits preserves the water of two lockages, beside presenting so many more points at which the canal can be supplied with water, from springs and rivulets above its level, or where, in less favorable situations, the same can be collected in a lower level to be pumped up. From one end of the proposed summit level it will be right now to proceed with the survey, tracing the level accurately and marking the same by pegs or stakes, that will last for some time, and be known by the surveyor, who is to follow and make a plan of the line; the levels being frequently transferred to what are called bench marks, upon the trunk of a tree, a large post, or a building, the same being noted so particularly in the field or survey book, that they may be readily found for years afterwards. We suppose the engineers, by this time, to have settled the rise that each lock should have, according to the dimensions adopted for the canal, the probable supply of water on the summit, and other circumstances; the summit level will be traced as above, till the proper place occurs for making a fall of two or more locks, at about 100 yards, or a little more from each other; and the places of these falls being marked, the level is again to be pursued and traced from the bottom of them, and marked out as before, till the opportunity occurs for another pair or more of locks, or till some obstacle, as a gentleman's park, houses, gardens, orchards, mills, roads, &c. present themselves at a distance; when it will be proper, after transferring the level arrived at to a proper and permanent mark, to proceed forwards, and to examine and well consider the different ways and levels, if more than one of such present themselves, by which the obstacle can be passed. From the most confined part of the course for the canal, owing to the obstacle, it will be right to level back, till the former work is met, and to determine the most eligible mode of bringing the two levels together, upon the principles before stated; if they can be applied, either by adding another lock, or taking one from any of the sets of them which had been before marked out, as occasion may require, and marking out the new levels thereby occasioned: the line between the summit and the first obstacle, or confined part of the course, being thus adjusted, a new point of departure is to be taken from such obstacle, and the level pursued as before, till the fall for a pair or more locks can be gained, at the proper distance from each other. In this way, the patience, perseverance, and abilities of the engineer must be exercised, until a practicable line of some length is obtained, and staked out; when the assistant land-surveyor must follow, and make a correct and particular plan of the line of the several proposed locks, embankments, tunnels, &c. upon the same, and of the several fields, or pieces of land through which it passes, or that come within 100 or 150 yards of it in any part: it will likewise be the business of the surveyor to ascertain, with the utmost care, the boundary of every parish and township, what county each is in, the proper names of the owners and occupiers of every piece of land in each, however small, upon or within that distance of the line, with reference to the same upon his plan; and to describe correctly all public and private roads and paths that cross or intersect the line, and to and from what places they lead; the course of all brooks or streams of water, and particularly such as lead to and contribute to the supply of any mill: the situation of the houses and towns upon the line, or within some miles of it, should also be determined; the nearer they are the greater accuracy will be necessary. A complete plan of the line, and all the projected collateral cuts, feeders, reservoirs, &c. being finished, the engineer will enter on a most careful revisal of the whole scheme, with this plan in his hand; on which all the places where culverts or drains will be required, are to be marked, as also the proper places for the bridges, and the necessary alterations of the roads and paths, which will be cut off by the canal, so that the public will not be inconvenienced and turned long distances round about, and still, that as few bridges as possible, and those in the least expensive places, may be erected. In some instances new channels will require to be cut for brooks and water-courses, to a considerable extent, in order to save culverts, or bring them to the most desirable spots. For proper security against accidental errors, the whole of the levelling should now be gone over again, and the several bench marks compared, and renewed with the utmost care by the engineer's assistants, while he is proceeding with the necessary inquiries and calculations, for an estimate of the whole expense of the undertaking.

3537. *The supplying of a canal with water*, in a great number of instances, occasions no inconsiderable share of the whole expense, either in the first cost of mills or streams of water, in land for, and labor in, constructing reservoirs, engines to pump water, &c.; or annually ever afterwards, in the fuel for, and repairing of engines, hire of water from mills in dry seasons, &c.; this subject should, therefore, employ the most sedulous atten-

tion of the engineer, both to make the most economical use of what streams he finds, to procure other supplies of water at the least expense, but above all, to secure an abundant sufficiency. The dimensions and heights of the locks, and breadth of the canal being settled, an accurate calculation made of the quantity of water required to fill a lock; and, with the largest probable number of boats that will pass in a day, the quantity required daily in every part of the canal; this, with a due allowance for the evaporation, from the surface of the whole canal and its reservoirs, and for the soakage that will take place into the banks, however well they are constructed; will show the number of locks full of water that will be required, from all the different sources.

3538. *In estimating the expense* of all such works, the lengths and solid contents of the several embankments, and the distance from which the stuff or soil must be fetched for the same; the lengths and dimensions of all the deep cuttings, and the distance to which the stuff must be removed; the lengths of the tunnels, and number and depths of the several shafts or tunnel pits will be necessary; the lengths or headings of soughs that will be wanted to drain the tunnelling work; these, and all the great variety of other works, some of which we have already mentioned, and others we shall have occasion to mention in the sequel, being particularly stated, and prices affixed to each species of work and kind of material; (and these prices ought not to be below the current prices of the best articles at the time, but due allowance should also be made for the advance of prices, which will take place during the advancement of the work;) the total probable expense, with a due allowance for contingencies, will be thus obtained, on which the engineer will prepare his general report and estimate, to be laid, with the plan, before a meeting of the adventurers or proposed proprietors.

### SECT. III. *Of the Powers granted to Canal Companies by Government.*

3539. *As a canal must pass through a great variety of private property*, and necessarily affect different individuals in very opposite ways, considerable powers are requisite to carry it into execution. The first step to attain these is the appointment of a solicitor, and an application to parliament for an act of incorporation and regulation.

3540. *A canal bill* contains numerous clauses; but the following may be considered as the heads of the most general.

*Regulations* as to raising money by shares or otherwise.

*Election* of committees and general meetings of proprietors.

*Enactments* relative to purchasing lands, &c.

*Powers* for erecting wharfs, and enforcing certain equitable rates of wharfage.

*Tolls*, or rates of tonnage, with exemptions, if any.

*Fixing mile-stones*, for regulating distances and tonnage.

*Removing the surface-soil*, and clamping it, for the purpose of being again laid on the surface of the exterior banks of the canal; or for other purposes.

*Forming watering places* for cattle or irrigation.

*Regulations as to mills*, &c.

*Power to make bye-laws*.

*Form of conveying land* to the canal company.

*Regulations as to depositing plans* of the canal, and making variations from them, &c.

3541. *The act of parliament for a canal being passed*, and therein the time and place for the first meeting of the subscribers or proprietors thereof being fixed; the first business of such meeting will be the election of a general committee of management, consisting of the most independent, respectable, and generally informed persons among the proprietors. The committee of management will then proceed to elect a chairman and subordinate officers; to fix upon their place of meeting, and to arrange the order of their business.

3542. *A resident engineer and land-surveyor and valuer* should now be fixed on, and probably also a local or select committee: auditors of accounts will be appointed, and salaries determined. The chief engineer will now revise the line, and divide it into different parts, assigning names to each for convenient reference. Of these distinct parts, or divisions, a separate account of the expenses should be strictly kept by the resident engineer, the overseers, or counters, as they are generally called, that the engineer is to recommend or employ upon the works, and by the office clerks in a ledger, with proper heads for each length of canal, set of locks, tunnel, embankment, deep-cutting, reservoir, aqueduct, or other great work, that may form a separate division: such particular and divided accounts of the works will prove of the most essential service to the committee, and to all others concerned, in informing and maturing their judgment on the actual or probable expense of every different kind of work; and will enable the committee to account to the proprietors how great, and sometimes unavoidable, as well as unexpected, expenses may be incurred.

3543. *Such lands as are wanted* should now be treated for by the land-surveyor, and the purchase and conveyance concluded with the approbation of the committee, and the aid of the solicitor, with or without the aid of the sheriff and a jury, as the case may require. In general, the ground for reservoirs and locks ought to be the first purchased, to permit the embankments and masonry to be proceeded with.

SECT. IV. *Of the Execution of the Works.*

3544. *The first operation of execution is the setting out of the work by the resident engineer and surveyor.* He will trace and mark the levels accurately of each pound or level reach of the canal, marking them with stakes, and comparing his work with the bench marks, and making two or more of the men who assist him perfectly acquainted with their situations, in case they should be deranged by cattle or otherwise

3545. *The calculations for excavation is the next part of execution.* The great desideratum in canal-digging is, that the stuff that is dug from one part of the work shall, with the least labor or distance of moving, exactly supply or form the banks that are to be raised in another, so that, on the completion of the work, no spoil banks, or banks of useless soil, shall remain, or any ground be unnecessarily rendered useless by excavations or pits. Six different cases will be found frequently to occur in the cutting or forming a canal. In each case the towing-bank (fig. 449 a.), is wider than the off-bank (b); and in all, the sides slope one and half feet for one foot in depth, that being found the least slope which can be given.

3546. *Where there is deep cutting on one side (c), or both (d, e), a bench or berm (c, e)*

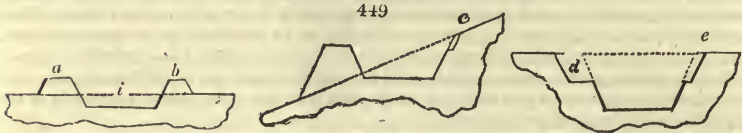

is provided to retain and prevent the loose earth that may moulder down from the upper bank from falling into the canal. The banks are usually made one foot higher than the water is intended to stand in them.

3547. *In level cutting (fig. 449 a, b),* the height of the canal should be so contrived, that in any cross section the sum of the areas of the made banks (a, b) should just equal that of the area of the section of excavation (i).

3548. *In side-lying ground (fig. 449 c, and fig. 450 f),* the same object may be attained with a little extra calculation; and in all other cases (g, h), the engineer will shew the

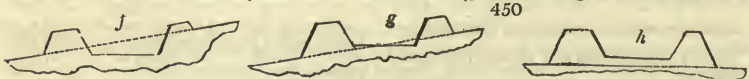

perfection of his skill in so conducting the line, that every embankment shall have deep cutting at both, or at least at one of its ends, to furnish the extra stuff with least expense in moving it; in like manner, every deep cutting (d, e) should have embankments at one or both of its ends, to receive the extra stuff.

3549. *Before cutting out the lock-split, or small trench between the several slope holes,* as a guide to the men who are to dig, the engineer ought to cause holes to be dug in the line of the canal, near every second or third level peg, or oftener, if the soil be variable, in order to prove the soil to a greater depth, by two or three feet, than the cutting of the canal is to extend; and each of these the engineer ought carefully to inspect, in order to determine what puddling or lining will be necessary; and what will be the difficulties of digging, owing to the hardness of the stuff, or to water that must be pumped out, &c.; all which circumstances, as well as the extra distance that any part of the stuff may require to be moved, must be well considered before the work can be let to the contractors.

3550. *The puddling or lining of a canal,* to make it hold water, is a matter of the greatest importance, and we shall consider five cases that are likely to occur or present themselves in the search into the soil that is to be dug, by sinking holes as above-mentioned. The first case we suppose to be that in which the whole is clay, loam, or other water-tight stuff; all soils that will hold water, and not let it soak or percolate freely through them, are called water-tight. Our second case is that in which the whole cutting will be in sand, gravel, loose or open rock, or any other matters that will let water easily through them, and such are called porous soils or stuffs. The third case, we suppose to have a thin stratum of water-tight stuff on the surface, and to have porous stuff for a considerable depth below. The fourth case may have porous stuff near the surface, and water-tight stuff at the bottom of the canal. The fifth case is that where water-tight stuff appears on the surface; and below this a stratum of porous stuff, but having again water-tight stuff at no great distance below the intended bottom of the canal. The new raised banks are always to be considered as porous stuff, as, indeed, they will always prove at first, and in a great portion of soils they would ever remain so, unless either puddling or lining was applied; all ground that has been dug or disturbed, must also be considered as porous. It should also be remarked, that any kind of soil which is perforated much by worms or other insects, should, in canal digging, be considered as porous stuff.

3551. *Puddle* is not, as some have attempted to describe it, a kind of thin earth mortar, spread on places intended to be secured, and suffered to be quite dry before another coat of it is applied; but it is a mass of earth reduced to a semifluid state by working and chopping it about with a spade, while water, just in the proper quantity, is applied, until the mass is rendered homogeneous, and so much condensed, that water afterwards cannot pass through it, or but very slowly.

3552. *The best puddling stuff* is rather a lightish loam, with a mixture of coarse sand or fine gravel in it; very strong clay is unfit for it, on account of the great quantity of water which it will hold, and its disposition to shrink and crack as this escapes; vegetable mould, or top soil, is very improper, on account of the roots and other matters, liable to decay, and leave cavities in it; but more on account of the temptation that these afford to worms and moles to work into it, in search of their food. Where puddling stuff is not to be met with, containing a due mixture of sharp sand, or rough small gravel stones, it is not unusual to procure such to mix with the loam, to prevent moles and rats from working in it; but no stones larger than about the size of musket bullets ought to be admitted.

3553. *That the principal operation of puddling* consists in consolidating the mass, is evident from the great condensation that takes place; it is not an uncommon case, where a ditch is dug, apparently in firm soil, that though great quantities of water are added during the operation, yet the soil that has been dug out will not more than two-thirds fill up the ditch again, when properly worked as puddle. It should seem also, that puddle is rendered by that operation capable of holding a certain proportion of water with great obstinacy, and that it is more fit to hold than transmit water. It is so far from true, that puddle ought to be suffered to get quite dry, that it entirely spoils, when by exposure to the air it is too much dried; and many canals which have remained unfilled with water during a summer, after their puddling or lining has been done, have thereby become very leaky, owing to the cracks in the puddle-ditches or lining. One of the first cares of an engineer, when beginning to cut a canal, is to discover whether good puddling stuff is in plenty, and if it be not, it must be carefully sought for, and carefully wheeled out, or reserved wherever any is found in the digging; or, perhaps, procured at considerable distances from the line, and brought to it in carts. It has happened in some stone brash or loose rocky soils, that all puddling stuff for several miles of the line, required to be brought to it; but even this expense, serious as it may be, ought not to induce the copying of those, who have left miles of such banks without puddling, and have made a winter canal, but which no stream of water that is to be procured can keep full in the summer months. It is usual in canal acts to insert a clause, for the security of the land-owners, to require the company to cause all the banks that need it to be secured by puddling, to prevent damage to the land below by leakage; and it would have been well for all parties, in many instances, if this clause had been enforced.

3554. *History of puddling.* It appears that the Dutch have been in the habit of making mud ditches to secure the banks of their canals and embankments, from time immemorial; and that operations similar to our puddling have been long known on the continent, but it is not clear at what period it was introduced into this country. We think that the fens in Cambridgeshire and Lincolnshire, in which so many works have at different times been executed by Dutchmen, are the most likely places in which to search for early evidence of its use. We cannot think that Brindley was the first who ever used it in this country, although we might admit that the Bridgewater canal was the first in which it was systematically used as at the present day. If we compare our first, fourth, and fifth cases (3550.), we shall find in all of them a water-tight stratum, as the basis; and the practice in these cases is to make a wall of puddle, called a puddle-ditch, or puddle-gutter, within the bank of the canal; these puddle-gutters are usually about three feet wide, and should enter about a foot into the water-tight stuff, on which they are always to be begun: and they should be carried up as the work proceeds, to the height of the top water-line, or a few inches higher. Our second and third cases (3550.), evidently will not admit of the above mode, because we have no water-tight stratum on which to begin a puddle-gutter, as a bottom: in these cases, therefore, it is usual to apply a lining of puddle to the sides and bottom of the canal.

3555. *Adjustment of materials.* Canals set out with the care that we have recommended, will always have the proper quantity of stuff to allow for the settlement of the banks, since the united sections of the loose banks will always equal the section of excavation in the same settled or consolidated state, in which it was before the digging commenced. The slopes of made banks, it is to be observed, on account of their settling, should be steeper in the first instance than they are ultimately required to be.

3556. *The letting of the cutting* of certain lengths of the canal to contractors, who will employ a number of navigators under them, in digging and puddling the canal, is the next business. It is usual to let the work at a certain price per cubic yard of

digging, and to pay for the puddling or lining either at a certain price per cubic yard, or per yard run of the canal. The engineer ought to inform himself thoroughly of the difficulties and facilities which attend the work he is about to let, and to draw up a short but explicit contract to be signed by the contractor. The prices allowed ought to be fair and liberal, according to the circumstances, so that the contractor may have no pretence, on account of low prices, to slight his work, particularly the puddling; and they ought in every instance to be strictly looked after; and made to undo and renew immediately any work that shall be found improperly performed. We recommend it to the engineer to keep a strict account, by means of his overseers or counters, of all the men's time that are employed upon the works; distinguishing particularly the number upon each work, and whether employed by the day, under the company, or upon the work that is let to contractors. These particulars are most essential towards knowing what money ought to be advanced to the contractor during the progress of his job, and towards informing and maturing the judgment of the engineer, in the length of time that a certain number of men will be in performing any future work he may have to direct; and a calculation ought to be made in every instance of the day-work, and compared with the contract price, by which alone a correct judgment can be formed of the proper prices at which work ought afterwards to be let, so that the laborers may receive proper wages, proportionate to their exertions, and the contractor be amply paid for his time, skill, and superintendance; and yet economy, and the interest of the company, be duly consulted.

3557. *Barrows and wheeling planks, horsing blocks, and other implements, are generally found by the company; and it is usual to consider twenty to twenty-five yards to be a stage of wheeling, and a price per cubic yard to be fixed according to the number of stages that the soil is to be moved: where this distance exceeds 100 yards, it will not often be eligible to perform it by wheel-barrows: and runs of plank with an easy descent, if the same is practicable, should be laid for large two-wheeled barrows, or trucks to be used thereon.*

3558. *Where the line of a canal is to cross an extensive stratum of valuable brick earth, or one of good gravel for making of roads, it will often be advisable, especially if the line can be rendered more direct thereby, when setting out the canal, to cut pretty deep into such materials, and even quite through the gravel, if the same is practicable; for although considerable expense will in the first instance be incurred in digging and in damage done for spoil banks, yet such materials as good brick earth and gravel, will in almost every instance find a market as soon as the canal is opened. Such a situation of the canal may prove of essential service to its trade, by enabling the adjoining proprietors to work the whole thickness of their brick earth, gravel, or other useful matters, and destroy but very little of the surface of the ground, and without being annoyed by water, but which the canal would catch in very considerable quantities, perhaps, instead of losing water by preserving a high level through porous stuff. In districts where stone and gravel for making and repairing of roads are scarce, it will be proper to pay the laborers certain rates per cubic yard for all the stones or gravel that they may collect out during the work, and stack in proper places; as resources for making of the towing-path, and for making good the landing or ascent to the several bridges, and the several pieces of new road that the engineer will have to form, near to the canal bridges; the lock banks, and all wharfs and landing places, should also be covered with good gravel to render them safe and convenient for use: if good gravel can in places be intersected in deep cuttings, much of the above expense, as well as of cartage, may be saved, by an early use of dirt boats in the bottom of the canal.*

3559. *How important and various the duties of the resident engineers are, must have struck every reader; but would be much more apparent, could we enter into the subject of reservoirs, feeders, aqueducts, embankments, culverts, safety gates, weirs, tunnels, deep cuttings, locks, substitutes for locks, inclined planes, railways, bridges, towing-paths, fences, drains, boats, towing or moving boats and trams, cranes and implements; but these, as less important for our purpose, we must leave the reader to study in the works of Phillips, Fulton, Chapman, Plymley, Badeslade, Kindersly, Anderson, Telford, and from the article Canal, in the three principal Encyclopædias.*

#### CHAP. VI.

*Of the Improvement of Estates by the Establishment of Mills, Manufactories, Villages, Markets, &c.*

3560. *Connected with the laying out of roads and canals, is the establishment of different scenes of manufactorial industry. The forced introduction of these will be attended*



with little benefit; but where the natural and political circumstances are favorable, the improvement is of the greatest consequence, by retaining on the same estate, as it were, the profits of the grower, manufacturer, and to a certain extent of the consumer.

3561. *The establishment of mills and manufactories to be impelled by water, necessarily depends on the abundance and situation of that material, and it should be well considered before hand, whether the water might not be as well employed in irrigation; or how far irrigation will be hindered by the establishment of a mill. In the state of society in which water corn-mills were first erected, they were doubtlessly considered as a blessing to the country. There were, then, no flour manufactories: and it was more convenient for the inhabitants to carry their corn to a neighboring mill, than to grind it less effectually, by hand, at home. Hence, the privileges and immunities of manorial mills. To secure so great a comfort, every tenant of a manor would willingly agree to send his corn to be ground at the lord's mill: and, perhaps, was further obliged to stipulate to pay toll for the whole of his growth; though it were sent out of the manor, unground.*

3562. *In Scotland, this impolitic, and now absurd custom, was only lately given up: till when no farmer dared to send his corn to market, until he had delivered a proportional quantity to the proprietor, or the occupier, of the mill to which he was thirled; or had previously stipulated to pay him thirlage, for what he might send away; this arbitrary regulation operating like tithes, to decrease the growth of corn.*

3563. *In England and Ireland, however, no restriction of this sort at present exists. But, in the remote parts of the north of England, there are mills which claim (or lately claimed) the exclusive right of grinding the whole of the corn which the inhabitants of the respective parishes or manors required to be ground, for their own use: suffering none to be sent out of the parish, for the purpose of grinding. And in the more western counties, where grist mills are still the schools of parochial scandal, something of this sort remains, and is piously preserved in modern leases. But, in the kingdom at large, grist mills are now going fast into disuse. Even working people purchase flour, instead of corn; and, whether in a private or a public light, this is an eligible practice. They can purchase a sort which is suited to their circumstances; and they know the quality and the quantity of what they carry home. Whereas, in the proverbial rascality of grist millers, they have no certainty as to either. Beside, in a flour mill there is no waste. Every particle may be said to be converted to its proper use.*

3564. *A valuable property belonging to modern flour manufactories is their not requiring every brook and rivulet of the kingdom to work them. In Norfolk, a great share of the wheat grown in that corn county, is manufactured into flour by the means of windmills. And such are modern inventions, that neither wind, nor water, is any longer necessary to the due manufacture of flour; the steam engine affording, if not the most eligible, the most constant and equable power.*

3565. *The most eligible species of water-mill, are the tide-mill, and the current-mill: the former placed in creeks, inlets, bays, estuaries, or tide rivers; and the latter in the current of a river. There are many situations, Marshal observes, in which these species of mills may be erected with profit to proprietors, and the community; and without an injury to the landed property, or the agricultural produce of the country. He is of opinion, that the numerous river mills existing in different parts of the country, are unnecessary to the present state of society.*

3566. *Grist mills in some remote situations, may be still required: but seeing the number of flour mills which are now dispersed over almost every part of the kingdom, seeing also the present facility of carriage, by land and water, and seeing, at the same time, the serious injuries which river mills entail on agriculture, Marshal recommends land proprietors to reduce their number, as fast as local circumstances will allow.*

3567. *The inducement to establish manufactories depends on a variety of circumstances, as well as on a supply of water. Among these may be mentioned the price of labor, convenience for carriage, export or import, existence of the raw material at or near the spot, as in the case of iron works, potteries, &c. In England, while the poor laws exist, the establishment of any concern that brings together a large mass of population will always be attended with a considerable risk to land owners; though it is a certain mode, in the first instance, of raising the price of land, and giving a general stimulus to every description of industry.*

3568. *A populous manufactory, even while it flourishes, according to Marshal, operates mischievously in an agricultural district: by propagating habits of extravagance and immorality among the lower order of tenantry, as well as by rendering farm laborers and servants dissatisfied with their condition in life; and the more it flourishes, and the higher wages it pays, the more mischievous it becomes in this respect. Lands bear a rental value in proportion to the rate of living, in the district in which they lie; so that while a tem-*

porary advantage is reaped, by an increased price of market produce, the foundation of a permanent disadvantage is laid; and whenever the manufactory declines, the lands of its neighborhood have not only its vices and extravagancies entailed upon them; but have the vicious, extravagant, helpless manufacturers themselves to maintain. This accumulation of evils, however, belongs particularly to that description of manufactory which draws numbers together in one place; where diseases of the body and the mind are jointly propagated; and where no other means of support is taught than that of some particular branch or branchlet of manufactory.

3569. *Cottages.* Wherever cottages for any class of men are built, whether singly or congregated, they ought never to be without an eighth or a tenth of an acre of garden ground. It is observed in *The Code of Agriculture*, that "where a laborer or country tradesman has only a cottage to protect him from the inclemency of the weather, he cannot have the same attachment to his dwelling, as if he had some land annexed to it; nor is such a state of the laborer so beneficial to the community. When a laborer has a garden, his children learn to dig and weed, and in that manner some of their time is employed in useful industry. If he is possessed of a cow, they are taught early in life, the necessity of taking care of cattle, and acquire some knowledge of their treatment. But where there is neither a garden to cultivate, nor any cows kept, they are not likely to acquire either industrious or honest habits. So strongly were these ideas formerly prevalent, that by the 43d of Elizabeth, no cottage could be built on any waste, without having four acres attached to it. This is now by far too much. If the quantity were reduced to half an acre for a garden, and if no person could gain a settlement who was not a native, or, if a stranger, who did not fairly rent in the same parish, a house and land worth twenty, instead of ten pounds per annum, both the poor and the public would thence derive very essential benefit.

3570. *Cottagers in England* have often no land or garden, but a right of common. This is of little or no real benefit to them, unless to obtain fuel, the advantage of which is great, and not easily compensated. With a common-right for a cow, or a few sheep, cottagers get an idea of visionary independence, which renders them unfit for the duties of their station. A laborer of this description is entirely spoiled for industry, and the generality of experienced persons in country matters must have seen many cases in point. Forest-side cottages in particular, are nurseries of idleness, and seminaries of mischief. In some cases, the cottager has good summer pasture, or can hire it in the neighborhood, and can raise, on arable land in his occupation, turnips and other winter food for a cow. This plan is adapted to countries, where there is a mixture of arable and grazing land; but it is objected to, in the more cultivated districts, as taking up too much of the time of the laborer.

3571. *The most advantageous system for keeping a cottage cow* is that adopted in grazing districts, where a cottager has a sufficient quantity of enclosed land in grass, to enable him to keep one or two cows both summer and winter, grazing the one half, and mowing the other, alternately. Nothing tends more materially to teach the poor honesty, than allowing them to have property which they can call their own. Feeling how intensely they would deprecate all infringement upon it, they are less likely to make depredations upon the property of others; and this will produce more honesty among them than the best delivered precepts can instil. By the cultivation of a small spot of land, a cottager not only acquires ideas of property, but is enabled to supply himself with that variety of food, as fresh vegetables in summer, and roots in winter, which comfort and health require. If he should fortunately be able to keep bees in his garden, and if its surplus produce should also enable him to rear, and still more to fatten a hog, his situation would be much ameliorated. But if, in addition to all these advantages, he can keep a cow, the industrious cottager cannot be placed in a more comfortable situation.

3572. *Cottages and villages* necessarily result from manufactories, as well as from extensive mines, quarries, or harbours. A few cottages will necessarily be scattered over every estate, to supply day laborers and some descriptions of country tradesmen. Villages are seldom, in modern times, created by an agricultural population; it being found so much more convenient for every farm to have a certain number of cottages attached to it.

3573. *A village* may be created any where, by giving extraordinary encouragement to the first settlers; but unless there be a local demand for their labor, or they can engage in some manufactory, the want of comfortable subsistence will soon throw the whole into a state of decay. Fishing villages, and such as are established at coal and lime works, are perhaps the most thriving and permanent in the kingdom. Some fine examples of fishing villages, recently established, occur on the marquis of Stafford's estates in Sutherland.

3574. *In forming the plan of a town or village*, the first thing, if there is a river or other means of communication by water, is to fix on a proper situation for a quay or harbour; and next, at no great distance from it, an open space as a market. Round the latter ought to be arranged the public buildings, as the post-office, excise or custom-house,

police-office, the principal inn and the principal shops. Near the harbour ought to be placed the warehouses and other depositaries for goods: In a retired part of the town the school; and out of town on an eminence (if convenient) the church and churchyard. There ought to be a field or open space as a public recreation ground for children, volunteers or troops exercising, races, washing and drying clothes on certain days, &c. Public shambles ought to be formed in a retired and concealed spot, and public necessities, and proper pipes, wells or other sources of good water, with the requisite sewers and drainage. Buckets, in case of fire, ought to be kept at the market-house.

3575. *The village of Bridekirk on the Annan, in Dumfrieshire (fig. 451.), was begun*

451

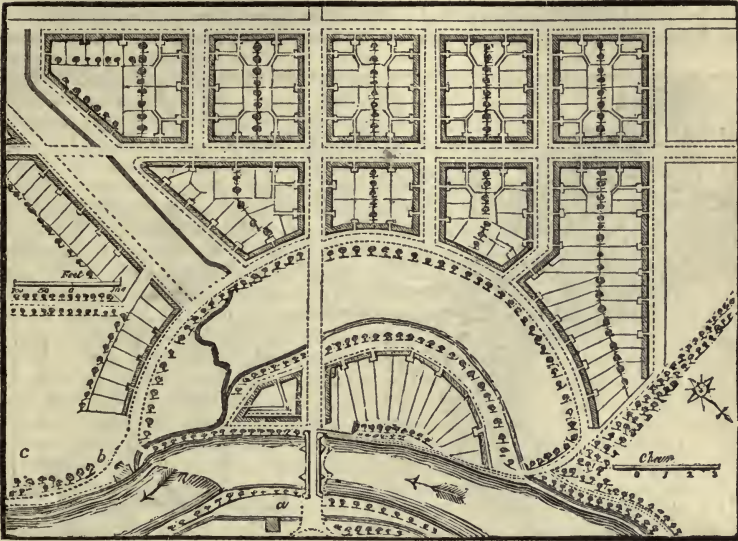

in 1800, by Gen. Dirom, and is thus described by him in the survey of the county. "It is situated at a part of the river, which affords falls and power, capable of turning any weight of machinery; and I have had it in view to give encouragement to manufacturers, to whom such a situation is an important object. A woollen manufactory (a) upon a large scale, and the most approved plan, has been established there for ten years, and is gradually increasing its machinery. In this village there are already, in the course of that time, about two hundred and fifty industrious inhabitants, and it has every appearance of a further rapid increase. On the opposite side of the river a situation is fixed on for corn-mills (b), where a complete set has been built upon the best construction, including wheat and barley mills. Half of the water there is reserved for any other works, and is likely to be let for a mill for dressing and for spinning flax, and for machinery required in bleaching, there being at the foot of the mill-race a holme of six acres (c), well calculated for a bleach field; and I propose to let part of it for such a manufactory.

3576. *The lots for building and gardens in the village, each consisting of from nine to ten falls of ground, are granted in perpetuity at the rate of six pounds the English acre, either upon leases for 999 years, or feu-rights, as the settlers choose: the former being generally preferred, as being the holding or title, attended with least expense. This rent would of itself be no object when the waste of ground in streets and enclosures is considered; but the great advantage to be derived from such an establishment is the increased value that lands acquire from having a number of industrious people settled in the heart of an estate. Each person who feus a house-stead is obliged to build with stone and lime, according to a regular plan; and a common entry is left between every two lots for access to their offices, which are built immediately behind their houses; and the whole of the buildings are covered with slate. The feuers are also bound to make a common sewer through their property when required; to pave ten feet in front of their houses, between them and the street; and to pay at the rate of a penny per fall yearly, according to the extent of their lots, to form a fund for keeping the streets and roads in repair, and for making small improvements. No person is allowed to sell liquor of any kind without my permission; nor can any shop or chandlery, tannery, or other work, that might be considered as a nuisance, be set up or built, unless in places allotted for these purposes; and to prevent all interference on the part of the feuers, I reserve to myself full liberty to*

make such alterations as may appear to me or my successors to be proper in the plan of the village. These regulations are the best security against having vagabonds in such a place, as none but industrious people can afford to build or rent such houses."

3577. *A new village sea-port in Devonshire* was formed by Sir Lawrence Palk, in the northernmost part of Torbay. A new pier, projected south-westwardly from the eastern cliff, affords complete protection to shipping from the south-east winds. The regularity of the buildings lately raised for the accommodation of company resorting hither for the convenience of sea-bathing, adds neatness and beauty to the wild and picturesque scenery of its natural situation; and, from the size of the vessels the harbour is now capable of protecting whilst they receive and discharge their cargoes, there are well-grounded expectations that this place will become of some maritime consequence on a future day. A plan of this sea-port (*fig. 452.*) is given in the *Devon Survey*, and is described as con-

452

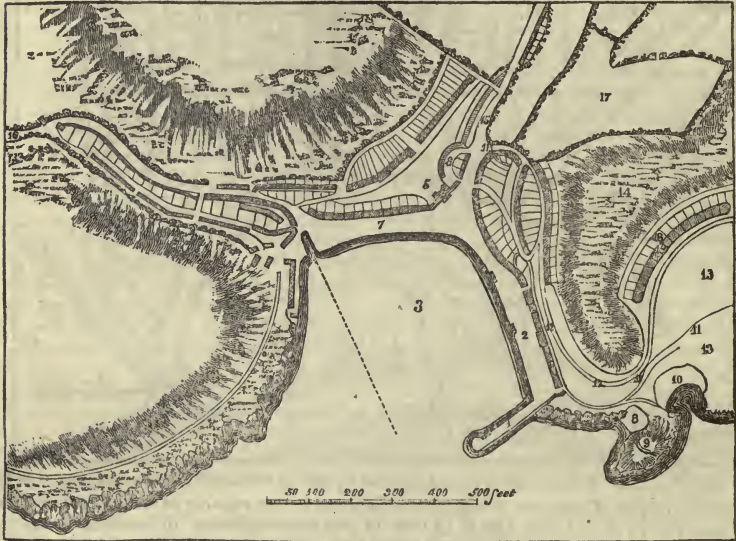

taining a pier (1), quay (2), harbour (3), warehouses (4), inn and garden (5), stables (6), strand (7), cove for building ships and timber yard (8), beacon (9), cove for bathing machines (10), new carriage way to the park (11), terrace (12), the park (13), plantation (14), road to Torwood (15), road from Newton, &c. (16), meadows (17), circus in the park (18).

## CHAP. VII.

### *Of Mines, Quarries, Pits, and Metalliferous Bodies.*

3578. *Against mines*, as a species of property, considerable prejudice has long existed from the variation of their produce, and the uncertainty of their extent and duration. Modern discoveries in geology, however, have thrown great light on the subject of mining, and introduced into the art a degree of certainty not before contemplated. As a proof of this, we may instance what used to be said as to coal and limestone: these minerals, according to tradition, exist in various parts of the island, where from the strata on the surface the modern geologist well knows it is impossible.

3579. *Among the various mineral substances found in quantity in Britain*, the chief are coal, lime, building and other stone, gravel, clay, fuller's earth, marl, &c. among the earths; salt, among saline substances; and lead, copper, and tin, among the metals. Cobalt, manganese, and some other metals and earths, are found in some places, but in small quantities. No saline or metalliferous bodies ought to be sought for, or attempted to be worked, but with the advice and assistance of an experienced and skilful mineral surveyor: nothing being more common than for proprietors to be induced by local reports or traditions to fancy their lands contain coal, lead, or some other valuable subterraneous pro-

duct, and to incur great expense in making abortive trials. To ascertain the nature and value of the minerals of an estate of any magnitude, or one of small size, but of peculiar exterior organization, it will always be worth while for the proprietor to have a mineral survey, map, and description, made out by a professional man.

3580. *Coal* is perhaps the most valuable British mineral, because, among other reasons, it does not appear to abound in any other country in such quantity and quality, as ever to lessen by importation the home produce. There are three species of coal, the brown, the black, and the unflammable. To the first belongs the Bovey coal or bituminised wood, found chiefly at Bovey, near Exeter; to the second the slate coal, which includes the pit and sea-coal, and all the kinds in common use, and also the canal coal, which occurs only occasionally in the coal pits of Newcastle, Ayrshire, and Wigan, in Lancashire; to the third belongs the Kilkenny coal, and Welsh culm, or stone coal which burns to ashes without flaming.

3581. *The indications of coal are different in different coal districts.* In general the surface is argillaceous or slaty, and limestone commonly forms an accompanying strata. In some collieries near Newcastle, however, limestone is wanting, but whinstone, sandstone, and others of secondary formation, are present in a great variety of forms.

3582. *The discovery of coal is made by boring,* and that operation is generally performed in coal districts as a guide for sinking new shafts. By this means the owners procure most essential data on which to proceed, being informed beforehand of the nature of the earth, minerals, and waters through which they have to pass; and knowing, to an inch or so, how deep the coal lies, as well as the quality and thickness of the stratum bored. It is confessedly of the first importance, either to the inhabitants of a district in general, or to the owners of the soil in particular, to be able to detect and work such veins of coal as may exist under their soil; and hence, we find, on enquiry in the neighborhood, that almost every common, moor, heath, or piece of bad land, in parts where coals are scarce, have at one time or other been reported by ignorant coal-finders to contain coal: how many times, for instance, have our grandmothers, and nurses, repeating their stories, told us, that plenty of coals might be dug at such and such a place, if government had not prohibited their being dug, for encouraging the nursery for seamen, &c.? Farcey's inquiries, and those of Smith, have brought to light hundreds of instances, where borings and sinkings for coals have been undertaken in situations, and on advice, in the southern and eastern parts of England; attended with heavy, and sometimes almost ruinous expenses to the parties, though a source of profit to the pretended coal-finders. These attempts a very slight degree of geological knowledge would have shown to be vain.

3583. *The coal fields of Britain* will be found scientifically described in *Outlines of Geology*, by Conybeare and Phillips, and also in *Bakewell's Geology*.

3584. *Limestone, chalk, and building or other stone,* are found in strata either on or near the surface. At a great depth it is seldom found worth while to work them. When stones of any kind are procured by uncovering the earth, and then working them out, they are said to be quarried; but when a pit or shaft is sunk, and the materials are procured by working under ground, they are said to be mined.

3585. *Gravel, chalk, clay, marl, and other loose matters,* when worked from the surface, are said to be worked from a pit, and hence the terms stone, quarry, gravel, clay, or marl pit. Little knowledge of geology is in general required for the discovery of gravel or marl; but still, even a little would be found of the greatest advantage.

3586. *The working of quarries* is a simple operation, and one depending more on strength than skill. In quarrying sandstone, consisting of regular layers, the work is performed chiefly by means of the pick, the wedge, the hammer, and the pinch or lever; recourse being seldom had to the more violent and irregular effects of gunpowder. But for many kinds of limestone, and for greenstone and basalt, blasting with gunpowder is always resorted to; and some of the rocks called primitive, such as granite, gneiss, and sienite, could scarcely be torn asunder by any other means.

3587. *The burning of lime* may be considered as belonging to the subject of quarrying. This operation is performed in what are called draw kilns, or perpetual kilns. These should always be close to or near the quarry, and either situated at a bank, or furnished with a ramp or inclined plane of earth for carting up the coal and lime to the top of the kiln. Lime-kilns may be built either of stone or brick; but the latter, as being better adapted to stand excessive degrees of heat, is considered as preferable. The outside form of such kilns is sometimes cylindrical, but more generally square. The inside should be formed in the shape of a hogshead, or an egg, opened a little at both ends, and set on the smallest; being small in circumference at the bottom, gradually wider towards the middle, and then contracting again towards the top. In kilns constructed in this way, it is observed, fewer coals are necessary in consequence of the great degree of reverberation, which is created above that which takes place in kilns formed in the shape of a sugar loaf reversed. Near the bottom, in large kilns, two or more apertures are

made; these are small at the inside of the kiln, but are sloped wider, both at the sides and the top, as they extend towards the outside of the building. The uses of these apertures are for admitting the air necessary for supplying the fire, and also for permitting the laborers to approach with a drag and shovel to draw out the calcined lime. From the bottom of the kiln within, in some cases, a small building called a horse is raised in the form of a wedge, and so constructed as to accelerate the operation of drawing out the burned limestone, by forcing it to fall into the apertures which have been mentioned above. In other kilns of this kind, in place of this building there is an iron gate near the bottom, which comes close to the inside wall, except at the apertures where the lime is drawn out. When the kiln is to be filled, a parcel of furze or faggots is laid at the bottom, over this a layer of coals, then a layer of limestone (which is previously broken into pieces, about the size of a man's fist), and so on alternately, ending with a layer of coals, which is sometimes, though seldom, covered with sods or turf, in order to keep the heat as intense as possible. The fire is then lighted in the apertures; and when the limestone towards the bottom is completely calcined, the fuel being considerably exhausted, the limestone at the top subsides. The laborers then put in an addition of limestone and coal at the top, and draw out at bottom as much as they find thoroughly burned; and thus go on, till any quantity required be calcined. When limestone is burned with coals, from two bushels and a half to three and a half, on a medium three bushels of calcined limestone, are produced for every bushel of coal used.

3588. *A very complete lime-kiln* on an improved plan, has been erected at Closeburn in Dumfriesshire, by Monteith. Instead of the wide and shallow circular kiln, these kilns are elliptical and deep. Some parts are added to it which are found of most important use. The first is a kind of roof or cover. The disadvantage of the want of some contrivance to protect kilns in stormy weather, has been long felt, and many attempts have been made to apply some kind of cover, but, we believe, none with such success as that used at Closeburn. The next addition is having cast-iron doors below, at the opening where the kiln is drawn. There is a grating, through which the ashes fall while drawing the kiln, which makes that operation a much less disagreeable employment than formerly; and the ashes and small lime thus separated are excellent for agricultural purposes. There is often a great loss of fuel, from allowing lime-kilns to cool when there is no demand; all that is necessary to be done, is, to shut the cast-iron doors, above as well as below, and the dampers in the chimneys. The heat is thus preserved, and fuel saved, by keeping the kiln hot, to be ready for use as soon as wanted. (*Farm. Mag.* vol. xvi. p. 134.)

3589. *Booker's lime-kiln* is of an oval form, twenty-two feet high, two feet wide at the bottom, nine feet in middle, and gradually contracted to three feet at top. It is lined with brick, and, instead of being covered with a dome, Booker adopts a cover of cast-iron with a vent in it, which cover is placed on a ring of three feet diameter, built into, and fixed on the top of the kiln. The cover, by moving on a pivot, is easily thrown off when the kiln is to be charged, and being put on during the process of calcination, it both increases the draught of air through the kiln, and by acting as a reverberatory furnace, is attended with a considerable saving of fuel. (*Dumfries Report*, p. 594.)

3590. *Burning lime in heaps.* Where fuel is abundant, lime may be burned in heaps as in charring woods, or in clumps like bricks. The fuel is intermixed, and the whole covered with turf or mud, in which a few holes are pierced to admit the passage of the smoke. (*Farm. Mag.* vol. xvii. p. 61.)

3591. *Machines for pounding limestone* have been erected, but the effect of the powder so obtained, both as a manure and for cement, is so much inferior to that of burnt lime, that they have long since been generally laid aside.

3592. *Salt* is procured from rocks, springs, and from the sea. In Cheshire, particularly in the neighborhood of Northwich, the salt works are very extensive. Great quantities are got in the solid form, but not sufficiently pure for use. In this state it is conveyed from the mines to the Cheshire side of the river, nearly opposite to Liverpool. It is at this place dissolved in the sea water, from which it is afterwards separated by evaporation and crystallization, by a process which we shall describe. There are also in the same district salt works, at which the salt called Cheshire salt is extracted from brine. These works are described very intelligibly by Dr. Holland, in *The Report of Agriculture for the County of Cheshire*. Considerable salt works are carried on in Scotland, and in the northern counties of England on the sea-coast, by the *evaporation of sea water*. At Lynton, in Hampshire, the sea water is evaporated to one-sixth of the whole by the action of the sun and air. The works in which the sea water is heightened into brine are called sun-works, or out-works. These are constructed on a flat down or oozy beach, within a mole, which is raised, if necessary, to keep out the sea; there is a large reservoir, or feeding pond, communicating with the sea by a sluice, and adjoining to this reservoir a long trench, parallel to which there are several square ponds, called

brine pots, in which the water is evaporated to a strong brine, and afterwards it undergoes an artificial evaporation and purification in boilers. (See 372.)

3593. *The metalliferous ores or stones* should never be sought after, but in consequence of the best advice and mature consideration. "Few," Marshal observes, "have made fortunes by mines, and many have been ruined by them." Should a man of large landed property, discover a productive mine on his estate, he offers him "two words of advice. The first is not to work it himself. A gentleman among miners is a pigeon to be plucked. Rather let the man who finds himself involved in such a predicament adopt the Cornish practice, and stipulate to take a proportional part of the ore which may be raised: according to the productiveness of the mine, and the expense of working it, jointly calculated. The other is not to break in upon the *principal*, or gross sum, which arises from a mine. If the estate is encumbered, remove the encumbrance. If not, increase its size; or, in any other prudent way, secure the *interest* of the gross produce of the mine: and thus defy the evil effects of its failure. *For no mine is inexhaustible.*"

## CHAP. VIII.

### *Of the Establishment of Fisheries.*

3594. *Fisheries* may be arranged as marine, river, lake, and pond fisheries: the first being of the greatest importance to this and every country.

#### SECT. I. *Of Marine Fisheries.*

3595. *The importance of improving the marine fisheries* to an insular country, like Britain, is sufficiently obvious. By their augmenting the quantity of food, there would necessarily result a reduction in the prices of all the necessaries of life; the condition of the laboring poor, the artificers, and tradespeople would as necessarily be improved: they would not only be the means of rearing and supporting a bold and hardy race of men for the defence of the sea-coast, but also of creating a nursery of excellent seamen for the navy in time of war, and of giving them employment when peace may render their further services unnecessary. If the fisheries flourished to that extent of which they appear to be capable, every sea-port town and little village on the coasts, or on the banks of the creeks and inlets, would become a nursery of seamen. It was thus in Holland, where the national and natural advantages were very inferior to those of Great Britain; for it is well observed, in the report of the Down's Society, that Holland produces neither timber, iron, nor salt, all of which are essential to fisheries; and all the natural produce of Great Britain; that Holland has no herrings on her own coast, while the coasts of our island abound with them and other fish, at different and all seasons of the year; so that there are few, if any, months in which shoals of this fish in particular are not found on some part of our shores; and that her population is under 3,000,000, while ours amount to about 18,000,000, giving to our fishermen six times the consumption of a home market that the Dutch have. With all the impediments to an extended use of fish in the home market, and notwithstanding the established character which the Dutch fish have always borne among foreign nations, it is consoling to find that the British fisheries are generally in a progressive state of improvement, and more particularly that most important of all their branches, the herring fishery.

3596. *The rapid progress of the herring fishery* shows, that there is no art or mystery in the catching and curing of herrings, that the English cannot accomplish as well as the Dutch, which is further proved by the successful experiment made by the Down's Society of fishermen; in the report of whose proceedings it is stated, that herrings had been taken within the Cinque Ports of a quality so nearly resembling the deep sea fish, that they were cured and sold as the best Dutch herrings. The progressive increase of the herring fishery is confined to Scotland; the quantity brought under the inspection of the officers in England amounts not to one-twenty-second part of the whole, while the flourishing little town of Wick alone furnishes nearly one-fifth. But the most extraordinary increase is that which has taken place in the neighboring county of Sutherland. Till a few years past, the people of this county were contented to hire themselves as fishermen to the adventurers of Wick. In 1814, they attempted, with the aid and encouragement of the mayor of Stafford, a fishery on their own account, and the mouth of the Helmsdale was fixed upon as the station. A storehouse and curinghouse were here erected; the boats were manned by the people brought from the mountains, and the interior of the country. Every thing was new to them in the employ they were about to engage. The fishing commenced on the 20th July, and ended on the 3rd September, 1814; and the four boats won respectively 105*l.* 3*s.*, 83*l.* 8*s.*, 96*l.* 8*s.*, and 148*l.* 3*s.* They were manned by four men each, so that they made, on an average, rather more than 27*l.* a man. In 1815, the number of boats employed amounted to fifty, almost entirely manned by Sutherland men; and

the number of barrels caught and repacked, exceeded 4,000, chiefly gutted. In 1817, this fishery gave employment to about 3,000 tenants, 17 coopers, and 180 women. In 1818, 70 coopers, 520 women, 700 men, 140 boats; and, in the present year (1819), the quantity caught and cured at Helmsdale, amounts to no less than 22,876 barrels, besides upwards of 100,000 cod and ling. While the herring fishery is making these rapid strides in the Highlands of Scotland, the ancient town of North Yarmouth, which owes its existence to the herring fishery, and in the time of Edward III. had an act usually called "The statute of herrings," passed in its favor, for the regulation of its herring fair, now exhibits only the small number of 1039 barrels.

5597. *The cod or white fishery*, including haddocks, whittings, ling, skate, halibut, flounders, &c. may be reckoned next in importance to the herring fishery. The whole extent of sea, from the neighborhood of the Orkney and Shetland islands, to Iceland on the one hand, and to the coast of Norway on the other, and along the eastern and western shores of Scotland, to the Flemish banks on the east, and the coast of Ireland on the west, may be considered as one great fishing domain, over which the different species of the cod genus are most plentifully dispersed; as are also turbot, skates, soles, haddocks, and whittings. These fish, which constitute collectively what is usually called the white fishery, surround, as it were, the whole of North Britain, and give to that portion of the united kingdom advantages which its southern neighbors cannot boast of.

5598. *The turbot fishery* is, perhaps, that alone which neither the Scotch nor the English follow up with equal success as the Dutch. The turbot fishery begins about the end of March, when the Dutch fishermen assemble a few leagues to the south of Scheveling. As the warm weather approaches, the fish gradually advance to the northward, and, during the months of April and May, are found in great shoals on the bank called the Broad Fourteens. Early in June, they have proceeded to the banks which surround the small island of Heligoland, off the mouth of the Elbe, where the fishery continues to the middle of August, when it terminates for the year. The mode of taking turbot is as follows: at the beginning of the season, the drag net is used, which, being drawn along the banks, brings up various kind of flat fish, as soles, plaice, thornbacks, and turbots; but, when the weather has driven the fish into deeper water, and upon banks of a rougher surface, where the drag net is no longer practicable, the fishermen have then recourse to the hook and line. Each line extends from one to nearly three miles in length, and is armed with six, seven, or eight hundred hooks, fixed to at a distance of several yards from each other. To keep these long lines properly stretched, and prevent their being carried away by the tide, heavy masses of lead in some places, and small anchors in others, are attached to them. The hooks are baited with the common smelt, and a small fish resembling the eel, called the gore bill. Though very considerable quantities of this fish are now taken in various parts of our own coasts, from the Orkneys to the Land's End, yet a preference is given, in the London market, to those caught by the Dutch, who are supposed to have drawn not less than 80,000*l.* a year, for the supply of this market alone; and the Danes from 12,000*l.* to 15,000*l.* a year, for sauce to this luxury of the table, extracted from about one million of lobsters, taken on the rocky shores of Norway; though our own shores are, in many parts, plentifully supplied with this marine insect, equal in goodness to those in Norway.

5599. *The mackerel fishery* is chiefly carried on off the coast of Suffolk and other southern counties; the season generally lasts about six weeks in May and June, and during which time fish to the value of 10,000*l.* or upwards, are caught off Suffolk alone. (*County Report.*)

3600. *Soles, gurnets, john dories, the red mullet, and other species*, are also caught off the southern coasts, and when the catch is greater than can be disposed of, they are salted and dried.

3601. *The stickle back* is caught in immense quantities in the Lynn river about once in seven years, and is purchased for manure at the rate of 6*d.* or 8*d.* a bushel.

3602. *The pilchard fishery* is carried on extensively on the coast of Cornwall. Enormous multitudes of these fish are taken on the coast of Devonshire as well as Cornwall, between the months of July and September inclusive, when the whole line of coast presents a scene of bustle and activity. The fish for foreign export and winter consumption are laid upon shore in large stacks or piles, with layers of salt between each row; here they are suffered to lay for twenty or thirty days, during which time a vast discharge of pickle mixed with blood and oil takes place, all of which is carefully caught in pits and preserved for manure, which is eagerly purchased by the farmer and carried away in casks. It is said that every pilchard will dress and richly manure one square foot of ground. The fish are then carefully washed with sea water, dried and packed in hogsheads, in which state they are sent abroad. The average value of pilchards taken in one year in Cornwall is supposed to be from 50,000 to 60,000*l.*

3603. *Lobsters, crabs, crawfish, shrimps, prawns, &c.* are caught generally on the south and east coast, but especially on the south and in the channel. The Scilly islands and the Land's End abound in lobsters, and crabs are to be found in most parts of the British shores.



3604. *The oyster* is to be found on most of the rocky shallows on the east and south coasts of Britain and Ireland. The most remarkable circumstances attending this fishery is the feeding or nursing of the oysters, which is almost exclusively practised in Essex. It has been tried, it is said, in the mouths of the Seine and some other rivers of France without success. The oysters are brought from the coast of Hampshire, Dorset, and other maritime counties, even as far as Scotland, and laid in the beds or layings in the creeks adjoining those rivers. The number of vessels immediately employed in the dredging for oysters are about 200, from twelve to forty or fifty tons burden each, employing from 400 to 500 men and boys. The quantity of oysters bred and taken in Essex and consumed annually, mostly in London, is supposed to amount to 14,000 or 15,000 bushels.

SECT. II. *Of River, Lake, and other Inland Fisheries.*

3605. *The only inland fishery of any importance* is that of the salmon. Salmon fisheries, Marshal observes, are "copious and constant sources of human food; they rank next to agriculture. They have indeed one advantage over every other internal produce: their increase does not lessen other articles of human sustenance. The salmon does not prey on the produce of the soil, nor does it owe its size and nutritive qualities to the destruction of its compatriot tribes. It leaves its native river at an early state of growth; and, going even naturalists know not where, returns of ample size, and rich in human nourishment; exposing itself in the narrow streams, as if nature intended it as a special boon to man. In every stage of savageness and civilization, the salmon must have been considered as a valuable benefaction to this country." This fish being rarely caught, except in estuaries or rivers, may be considered in a great degree as private property, and it may therefore be presumed that the fishery is conducted to the greatest possible extent and advantage. From the extremity of the Highlands, and from the Orkney and Shetland islands, these fish are sent up to the London market in ice; and when the season is at its height, and the catch more than can be taken off hand fresh, they are then salted, pickled, or dried, for winter consumption at home, and for the foreign markets. Perhaps the fishery of the Tweed, is the first in point of the quantity caught, which is sometimes quite astonishing, several hundreds being taken at a single draught of the net.

3606. *The salmon as they are caught are packed in ice,* and sent away in vessels well known under the name of Berwick smacks. Formerly it was all pickled and kitted, after being boiled, and sent to London under the name of Newcastle salmon; but the present mode has so raised the value of the fish, as nearly to have banished this article of food from the inhabitants in the environs of the fishery, except as an expensive luxury. Within memory, salted salmon formed a material article of economy in all the farm houses of the vale of Tweed, insomuch that indoor servants often bargained that they should not be obliged to take more than two weekly meals of salmon. It could then be bought at 2s. the stone, of nineteen pounds weight; it is now never below 12s., often 36s., and sometimes two guineas.

3607. *With respect to the improvement of salmon fisheries,* admitting that the individual fish which are bred in any river, instinctively return to the same from the sea, the most obvious means of increase in any particular river, is that of suffering a sufficient number of grown salmon to go up to the spawning grounds; protecting them while there, and guarding the infant shoals in their passage from thence to the ocean. Even admitting that those which are bred within the British islands, and escape the perils that await them, return to these islands, it is surely a matter of some importance, viewed in a public light, to increase and protect the breed. It is a well ascertained fact, that salmon pass up toward the spawning grounds of different rivers at different seasons, or times of the year; consequently, no one day in the year can be properly fixed by law to give them free passage up rivers in general. Each river of the island should have its particular day of liberation; which ought to be some weeks before the known close of the spawning season, in a given river. The better to assure the ascent of salmon after the day of liberation, all mills, weirs, and other obstructions, whose proprietors have, by ancient custom, the right of taking salmon, ought to be under legal regulations; and to be liable to the free inspection, not only of other proprietors of the same river, but of the public in general; to see that a free, obvious, and easy passage be made for the fish to ascend; the law making it equal felony to destroy or wilfully to obstruct, after the days specified, salmon passing up to a spawning ground. And the more effectually to protect the spawning grounds, let the same penalty be there perpetual. Let each branch of every river have a fixed point, above which it shall be felony to destroy salmon wilfully at any season of the year. This regulation would, it is conceived, be of essential use. For, in times of floods, it is not all the vigilance of man, nor scarcely any obstacle he can raise, which is able to prevent salmon that are near their time of spawning, from ascending the upper branches of rivers; namely, the brooks and rivulets here proposed to be strictly guarded by law. But they rarely enter these before they are

in that state; and, in course, until they are unfit for human food. Hence, the proprietors of spawning streams would have little reason to complain of such a regulation.

3608. *In a dry season, and for want of flood water* to assist them in their extraordinary efforts to gain the higher branchlets of a river, the salmon will spawn in its lower deeper parts. But here, it is probable, few of their progeny escape the voracity of fish of prey, which inhabit deep waters. While, in the shallow, pebbly streams, at the heads of which they delight to lay their spawn, the infant shoal is free from danger. And it is for this security, no doubt, that the instinct of the parents leads them to the greatest attainable height, — at the peril of their own lives! Thus far, as to the protection of the parents, and their infant spawnlings. It now remains to guard these, from their native streamlets to the sea.

3609. *The enemies of young salmon* are fish of prey; as the pike, and trouts of size: both of which ought to be considered as vermin, in rivers down which samlets are wont to pass.

3610. *The hern* is another destructive enemy of young salmon: especially in the higher branches of rivers. Yet we see these common destroyers nursed up in herneries! But more wisely might the cormorant be propagated and protected. The hern is tenfold more destructive of fresh-water fish, than is the cormorant.

3611. *The otter* is a well known enemy of fish: but more so to grown salmon than to their young.  
3612. *The angler* is a species of vermin which is much more injurious than the otter to young salmon; during minor floods, when the young "fry" are attempting to make their escape downward to the sea, the angler counts his victims by the score; and might boast of carrying home, in his wicker basket, a boat load of salmon. The net fisher is still more mischievous. But most of all the miller, who takes them, in his mill traps, by the bushel, or the sack, at once.

3613. *The porpoise*, the most audacious fish of prey in northern latitudes, is said to be a great devourer of salmon and other fish on the sea-coast, and in narrow seas and estuaries. It is asserted by those who have had opportunities of ascertaining the fact, that they not only destroy salmon in the narrow seas, and open estuaries, but that they have been seen guarding the mouth of a river, in the salmon season, and destroying them, in numbers, as they attempted to enter. If these are facts, it might be worth while for the proprietors of fisheries, or perhaps government, to offer rewards for catching this animal, and thus lessen their number on the same principles as wolves were extirpated.

3614. If it were asked what *punishment* is due to the crimes of such men, the answer would be apt. If a miller, a net fisher, or an angler of young salmon were detected in digging up the seedling plants of a field of corn, or destroying the young lambs of his neighbor's flock, what punishment would be due to him? This the law would readily determine. And let the punishment for destroying young salmon be neither more nor less. If it is a fact that salmon return to their native rivers, and if the whole of a salmon river belongs to one proprietor, the crime of destroying young salmon becomes perfectly analogous with that of destroying the young of agricultural animals. And it behoves the proprietors of salmon fisheries, no matter whether they are entire or joint properties, to protect the one with the same zeal and assiduity as the other. Even supposing this commonly received opinion to be ill founded; yet, admitting that the whole, or the principal part, of the salmon which are annually brought to market, are bred in the rivers of these islands, it necessarily follows, that the greater number there are bred, and protected to the sea, the greater prospect there will be of the markets being plentifully supplied in future.

3615. If by *wise regulations, formed into a law*, the present supply could be doubled, the advantage to the community would be of some importance. When we see the great disparity of the supply, between the rivers of the north, and those of the south, of this island, it might not be extravagant to imagine, that the supply from the rivers of England might be made five or ten times what it is at present. One of the first steps towards regulations of this nature is to endeavor to ascertain the causes of this disparity; and to profit by such as can be subjected to human foresight and control. Accurate examinations of the Tay, the Tweed, the Trent, and the Thames, would perhaps be found adequate to this purpose.

3616. There are various *modes of taking salmon*, some of which may be mentioned; though it is foreign to our plan to enter into the art of fishing, which is practised by a distinct class of men, created, as it may be said, more by circumstances, than regular apprenticeship or study. The situations in which salmon first attracts the particular attention of fishermen, are narrow seas, estuaries, or mouths of rivers; — in which they remain some time, — more or less, probably, according to their states of forwardness with respect to spawning; and in which various devices are practised to take them.

3617. In the wide *estuary of the Solway Firth*, which separates Cumberland and Dumfriesshire, there are two of the several ingenious methods there practised, which are entitled to particular notice here. Beside the open channels which are worn by the Esk, the Eden, and other rivers and brooks that empty themselves into this common estuary, the sands of which its base is composed, and which are left dry at low water, are formed into ridges and valleys, by the tides and tempestuous weather. The lower ends of these valleys, or false channels, are wide and deep; opening downward, towards the sea: their

upper ends growing narrower, and shallower, until they close in points, at the tops of the sand banks. As the tide flows upward, the salmon, either in search of food, or the channel of the river to which they are destined, enter these valleys or "lakes." But finding, on the turn of the tide, that their passage further upward is stopped, they naturally return with it into deep water; where they remain until the next tide. The mariorial proprietors of these sand-banks having discovered this fact, have, from time immemorial, run lines of nets, during the fishing season, across the lower ends of these lakes or valleys, half a mile or more, perhaps, in width; the nets being suspended in such a manner, that they are lifted from the ground by the current of the tide in flowing upward; so that the fish find no difficulty in passing beneath them into the lake. But, on the tide's turning, their lower edges fall down close to the sand, and effectually prevent the salmon from retreating. They are, in consequence, left dry, or in shallow water, easily to be taken by hundreds perhaps, at once.

3618. The other remarkable method, which is practised in the Firth of Solway, is founded on a well-known habit of salmon, when they first make the land, and enter into narrow seas and estuaries, to keep much along the shore: no matter, whether to hit, with greater certainty, their native rivers, or to rub off the vermin, with which, in general, they are more or less infested, when they return from the ocean, or in search of food. This method of taking salmon, if not a modern invention, has recently been raised to its present degree of perfection, by an enterprising salmon fisher and farmer in the neighborhood of Annan; who has turned it to great profit. At a short distance below the mouth of the river Annan, he has run out a long line of tall net fence, several hundred yards in length, and somewhat obliquely from the line of the shore, with which it makes an acute angle, and closes in with it, at the upper end: thus forming, in effect, an artificial lake; one side of which is the beach, the other the net fence. The lower end is ingeniously guarded, with nets of a more trap-like construction than those which are in use for natural lakes; in which fish are found to lie more quietly, until the turn of the tide. In this immense trap, great quantities, not of salmon only, but of cod, ling, soals, and other white fish are taken. Marshal knows no place in the island where sea fishing, for salmon, can be studied with so much profit as on the shores of Annandale.

3619. *River fishing for salmon* is chiefly done with the seine, or long draught net, whose construction and use are universally known. In rivers which are liable to frequent and great changes of depth, and strength of current, by reason of tides and floods, it is desirable to have nets of different textures, as well as of different depths: as, one of the construction best adapted to the ordinary state of the water, and to the size of the fish that frequent it (salmon peels, trouts, mullets, and other small sized fish are, in some rivers, commonly taken with salmon); and another with more depth, and wider meshes; to be used during high water and strong currents, when the larger salmon do not fail to hasten upward: and the same strength of hands which is able to draw a close shell on it, can work a deeper one with wider meshes. In wide rivers, with flat shores, a variety of nets are required of different lengths as well as depths, to suit every height and width of the water.

3620. *In rivers traps are set for salmon.* The most common device of this kind is the weir, or salmon leap; namely, a tall dam run across the river, with a sluice at one end of it, through which the principal part, or the whole, of the river at low water, is suffered to pass with a strong current; and in this sluice the trap is set.

3621. *The construction of salmon weirs,* Marshal conceives to be, in all cases, dangerous, and in many highly injurious to the propagation of salmon. And although it would be altogether improper to demolish those which long custom has sanctioned, yet he is of opinion that it would be equally improper to suffer more to be erected; at least, until some judicious regulations are made respecting them: regulations which cannot be delayed without injury to the public.

3622. It now only remains to speak of *poaching, or the illegal taking of grown salmon.* There are already severe penalties inflicted for this crime; which, compared with that of destroying young salmon, might, in a public light, be deemed venial; the latter deserving tenfold punishment. For the grown salmon that are taken, in season, by poachers, becomes so much wholesome food. There is no waste of human sustenance by the practice. Nevertheless, as theft, the crime is great, and ought to be punishable as such. As an improvement of the present law, Marshal proposes to make the receiver, in this as in other cases of theft, equally punishable with the thief. If poachers were not encouraged by purchasers of stolen salmon, the practice would not be followed.

3623. *Lake fisheries* are of small extent, and are chiefly confined to one or two mountainous districts; and, even there, unless where char or trout abound, as in Keswick and Lochlomond, their value is small, and their improvements few. The Lochfine fishery is to be considered as marine, it being in fact an inlet of the sea.

3624. *Pool fishing* is, in most parts, peculiar to the seats of men of fortune, and the country residences of minor gentlemen. Surrey and Berkshire are, perhaps, the only

districts in which fish pools are viewed as an object of rural economy. On every side of the metropolis, something of this kind is observable. But it is on the south side, in adjoining parts of Surrey and Sussex, where the practice of fish breeding may be said to be established. There fish pools have been, and still are formed with the view of letting them to dealers in carp and other pond fish; or of stocking them, and disposing of the produce, as an article of farm stock, as pigs; rabbits, poultry, or pigeons. In a general view of the kingdom, fish pools can scarcely be considered as an object worthy of consideration, in the improvement of landed estates. Yet there are situations, in which they may be formed with profit: as in the dips and hollows of extremely bad ground; especially if waters, which are genial to any of the species of pond fish, happen to pass through them, or can be profitably led to them. Even where the water, which can be commanded, is of an inferior quality, a profitable breeding pool may be formed, to stock ponds of a more fattening nature.

3625. *The craw-fish*, though most delicious eating and a native of England, neither abounds in sufficient quantities to be brought to market nor is reared by individuals. It requires warm rich marshy lands, and a calcareous soil.

3626. *The leech* is an amphibious animal of the mollusca order, common about some of the lakes in the north of England, as Keswick. Formerly considerable quantities used to be picked up and sent to London, and other places; but the market is now chiefly supplied from the continent.

---

#### CHAP. IX.

##### *Of Plantations and Woodlands.*

3627. *Without trees*, a landed estate may be very profitable on account of its mines, waters, and farm lands; but it will be without the noblest characteristic of territorial surface. It may possess the beauty of utility in a high degree, and especially to the owner; but it will not be much admired by the public, nor contribute greatly to the ornament of the country — for what is a landscape without wood? It is not meant, however, that plantations of trees should be made on estates for the sake of ornament; on the contrary, none need ever be made which shall not be at the same time useful, either from the products of the trees individually, or their collective influence on surrounding objects.

3628. *Trees have been planted and cherished in all countries, and from the earliest ages*; but the formation of artificial plantations chiefly with a view to profit, appears to have been first practised, on a large scale, about the end of the sixteenth century, when the insufficiency of the natural forests, which had hitherto supplied civilized society in England with timber and fuel, rendered planting a matter of necessity and profit. In the century succeeding, the improved practice of agriculture created a demand for hedges and strips for shelter; and the fashion of removing from castles in towns and villages to isolated dwellings surrounded by verdant scenery, led to the extensive employment of trees both as objects of distinction and value. For these combined purposes, planting is now universally practised on most descriptions of territorial surface, for objects principally relating to utility, and in all parks and grounds surrounding country residences for the joint purposes of utility and beauty.

3629. *Woodlands* are lands covered with wood by nature, and exist more or less on most extensive estates. Sometimes it is found desirable partially or wholly to remove them, and employ the soil in the growth of grass or corn; at other times their character is changed by art, from coppice or fuel woods, consisting of growths cut down periodically, to trees left to attain maturity for timber.

3630. *In our view of the subject of trees*, we shall include some remarks on improving and managing woodlands, which might have been referred to the two following Books; but for the sake of unity we prefer treating of every part of the subject together. The ornamental part of planting, we consider, as wholly belonging to gardening, and indeed the entire subject of trees may be considered as equally one of gardening and of agriculture, being the link by which they are inseparably connected. For a more extended view of the subject, we refer to our *Encyclopædia of Gardening*, and *Encyclopædia of Plants*: in the former will be found all that relates to the culture of trees collectively; in the latter, all that relates to their botanical character, history, uses, height, native country, and other subjects, with their individual propagation, soil, and culture. We shall here confine ourselves to the soils and situations proper for planting, the trees suitable for particular soils and situations, the operations of forming and managing artificial plantations, and the management of natural woods.

SECT. I. *Of the Soils and Situations which may be most profitably employed in Timber Plantation.*

3631. As a *general principle of guidance in planting*, it may be laid down that lands fit for the purposes of aration should not be covered with wood. Where particular purposes are to be obtained, as shelter, fencing, connection, concealment, or some other object, portions of such lands may require to be wooded; but in regard to profit, these portions will always be less productive than if they were kept under the plough. The profits of planting do not depend on the absolute quantity of timber produced, but on that quantity relatively to the value of the soil for agricultural purposes. Suppose a piece of ground to let at 20s. per acre, for pasture or aration, to be planted at an expense of only 10l. per acre; then in order to return the rent, and 5l. per cent. for the money expended, it ought to yield 30s. a year; but as the returns are not yearly, but say at the end of every fifteen years, when the whole may be cut down as a copse, then the amount of 30s. per annum, at 5l. per cent. compound interest, being 32l. 8s., every fall of copse made at the interval of fifteen years ought to produce that sum per acre clear of all expenses. Hence, with a view to profit from the fall of timber, or copse wood, no situation capable of much agricultural improvement should be planted.

3632. *The fittest situations for planting extensively* are hilly, mountainous, and rocky surfaces; where both climate and surface preclude the hope of ever introducing the plough; and where the shelter afforded by a breadth of wood will improve the adjoining farm lands, and the appearance of the country. Extensive moors and gravelly or sandy soils may often also be more profitably occupied by timber trees than by any other crop, especially near a sea-port, coaleries, mines, or any other source of local demand.

3633. *On all hilly and irregular surfaces* various situations will be indicated by the lines of fences, roads, the situations of buildings, ponds, streams, &c. where a few trees, or a strip, or mass, or row, may be put in with advantage. We would not, however, advise the uniform mode of planting recommended by Pitt in his *Survey of Staffordshire*, and in *The Code of Agriculture*; that of always having a round clump in the point of intersection of the fences of fields. This we conceive to be one of the most certain modes ever suggested of deforming the surface of a country by planting; the natural character of the surface would be counteracted by it, and neither variety nor grandeur substituted; but a monotony of appearance almost as dull and appalling as a total want of wood.

3634. *Near all buildings* a few trees may in general be introduced; carefully however avoiding gardens and rick-yards, or to shade low buildings. In general fewest trees should be planted on the south side of cottages; and next on their north-west side; farms and farm buildings in very exposed situations (*fig. 453.*) and also lines of cottages, may be surrounded or planted on the exposed side by considerable masses.

453



3635. *Wherever shelter or shade is required* plantations are of the first consequence, whether as masses, strips, rows, groups, or scattered trees; all these modes may occasionally be resorted to with advantage even in farm lands.

3636. *Wherever a soil cannot by any ordinary process be rendered fit for corn or grass, and will bear trees*, it may be planted as the only, or perhaps the best mode of turning it to profit. There are some tracts of thin stony or gravelly surfaces covered with moss, or very scantily with heath, and a few coarse grasses, which will pay for no improvement whatever, excepting sowing with the seeds of trees and bushes. These growing up will, after a series of years, form a vegetable soil on the surface. The larch, Scotch pine, birch, and a species of rough moorland willow (*salix*) are the only woody plants fit for such soils.

3637. *Wherever trees will pay better than any other crop* they will of course be planted. This does not occur often, but occasionally in the case of willows for baskets and hoops, which are often the most profitable crop on moist deep rich lands; and ash for hoops and crate ware, on drier, but at the same time deep and good soils.

SECT. II. *Of the Trees suitable for different Soils, Situations, and Climates.*

3638. *Every species of tree will grow in any soil*, provided it be rendered sufficiently dry; but the effects of soils on trees are very different, according to the kind of tree and the situation. A rich soil and low situation will cause some trees, as the larch and common pine, to grow so fast that their timber will be fit for little else than fuel; and the oak, elm,

&c. planted in a very elevated situation, whatever be the nature of the soil, will never attain a timber size. In general, as to soils, it may be observed that such as promote rapid growth, render the timber produced less durable, and the contrary; that such soils as are of the same quality for a considerable depth are best adapted, other circumstances being alike, for ramose-rooted trees, as the oak, chestnut, elm, ash, and most hard-wooded trees; and that such soils as are thin, are only fit for spreading or horizontal rooted trees, as the pine and fir tribe.

3639. *A table of soils and the trees suitable to them* is given in *The Agricultural Survey of Kent*, which may be of some use. It indicates the trees which grow naturally on a variety of soils and subsoils, which may be considered its greatest merit; and next the sorts which may be planted on such soils as yielding more profit; with the application to use or form in which that profit is obtained.

Surface Soil.	Subsoil.	Common Growth.	Planted Growth.	Uses of.
Heavy and gravelly loams.	Heavy loam with chalk.	Birch, hornbeam, oak, ash, hazel, beech, &c.	Oak, ash, chestnut, willow, lime, walnut.	Timber, hop-poles, cordwood, hurdles, bavins for bakers, and lime-works.
Sandy loams.	Heavy loam.	Ditto.	Elm, beech, Weymouth pine, common spruce.	Ditto.
Flinty strong loam.	Heavy loam.	Ditto.	Willow and chestnut.	Timber, fencing poles, and as above.
Gravelly and sandy loams.	Gravelly loam.	Ash, beech, oak, hazel, &c.	Chestnut, ash.	Hop-poles, fencing poles, and all as above.
Gravelly, sandy, and flinty loams.	Heavy gravelly flinty loam.	Ash, beech, hornbeam, and oak.	Ash, beech, larch, &c.	Timber, fencing, hop-poles, cordwood for charcoal, bavins, &c.
Flinty, dry, poor gravelly loams.	Chalk at 2 feet depth with gravelly loam.	Beech, oak, &c.	Beech, larch, &c.	Cordwood, bavins, and hop-poles.
Flinty and gravelly loams.	Chalk 4 feet with deep gravelly loam.	Ash, oak, hazel, &c.	Ash, larch, &c.	Cordwood, hop-poles, bavins, stakes, ethers, &c.
Ditto.	With a few flints, but nearly as above.	Oak, hazel, beech, and ash.	Chestnut, ash, and willow.	Hop-poles, fencing poles, stakes, cordwood, &c.
Lightish black loam.	Dry sandy gravel.	Birch, elm, ash.	Ash, elm, &c.	Various uses in husbandry.
Flinty gravelly loams.	Strong loam with flints.	Oak, ash, beech, &c.	Ash, &c.	Poles, bavins, cordwood, &c.
Chalky, flinty, gravelly loam.	Chalk, with some gravelly loam.	Ditto.	Ditto.	Ditto.
Gravelly loam.	Heavy flinty and poor loam.	Oak, ash, hazel, and beech.	Ash, oak, &c.	Common produce a few poles, cordwood, bavins, &c. plantation many poles, and the above.
Gravelly and chalky loams.	Gravelly loam with chalk.	Oak, ash, &c.	Ash and chestnut.	Poles, cordwood, &c.
Gravelly loam.	Ditto.	Ash, oak, & beech, Ditto.	Oak, larch. Scotch pine.	Ditto
Ditto.	Gravelly loam and heavy loam.	Ditto, Scotch pine.	Larch, chestnut, &c.	The same
Sandy gravel.	Gravelly and sandy loam.	Ditto, Scotch pine.	Larch, chestnut, &c.	Poles, stakes, ethers, &c. &c.
Stone, shatter, and gravelly loam.	Strong loam with ragstone.	Oak, hazel, birch, &c.	Birch, oak, &c.	Oaken tillers, small timber poles, &c.
Stone, shatter, and gravelly loam.	Gravelly loam with some stone.	Oak, birch, aspen, hazel, and ash.	Ash, chestnut, and willow.	Fencing poles, hop-poles, cordwood, &c.
Gravelly loam.	Gravelly loam with some stones.	Oak.	Chestnuts.	Hop-poles, fence poles, &c.
Sandy loam.	Gravelly loam.	Birch, oak, hornbeam, &c.	Chestnut, &c.	Fence poles, hop-poles, &c.
Sandy loam and stone shatter.	Gravelly loam with ragstone.	Oak, beech, birch, hazel, ash.	Ditto.	Ditto.
Gravelly loam and stone shatter.	Deep loam, heavy clay and gravel.	Ditto.	Ditto.	Ditto.
Ditto.	Gravelly loam.	Oak, and ditto.	Ditto.	Ditto.
Gravelly and sandy loam.	Strong clay and loam.	Oak, and ditto.	Ash, larch, &c.	Poles, fire-wood, &c. as above.
Gravelly loam flinty.	Gravel with clay and some flint.	Scrubby oak, hazel, &c.	Oak, ash.	Timber and ditto.
Wet spongy land.	Moist and boggy earth.	Alder, willow.	Alder, osier, willow, &c.	Hurdles, hop-poles, &c.
Drier ditto.	Ditto more dry.	Poplar.	White poplar, willow.	Hop-poles, &c.
Light sandy loam.	Dry gravelly earth.	Mountain ash, ash.	Scotch pine, silver fir.	Hop-poles.
Light gravelly loam.	With dry gravel.	Ash.	Sycamore.	Timber-turnery, &c.

3640. *With respect to climate*, the species of tree which grows nearest the regions of perpetual snow are the birch, common pine, white beam, larch, mountain ash, and elder. A warmer zone is required for the sycamore and hornbeam; and still more for the beech, ash, elm, and maple. The evergreen firs prefer dry sheltered dingles and ravines, not far up the sides of hills; and the oak, chestnut, lime, poplars, tree willows, and a variety of American trees, will not thrive at any great elevation above the sea. The hardest shore trees are the sycamore, beech, and elder; but on sheltered shores, or such as are little subject to the sea-breeze, pines, firs, and most sorts of trees will thrive.

3641. *The sort of product desired from planting*, as whether shelter, effect, or timber, copse, bark, fuel, &c. and what kinds of each, must be in most cases more attended to than the soil, and in many cases even than the situation. The thriving of trees and plants of every kind, indeed, depends much more on the quantity of available soil, and its state in respect to water and climate, than on its constituent principles. Moderately sheltered and on a dry subsoil, it signifies little whether the surface strata be a clayey, sandy, or calcareous loam; all the principal trees will thrive nearly equally well in either, so circumstanced; but no tree whatever in these or in any soil saturated with water, and in a bleak exposed site. For hedge-row timber, those kinds which grow with lofty stems, which draw their nourishment from the subsoil and do least injury by their shade, are to be preferred. These, according to Blakie, are oaks, narrow-leaved elm, and black Italian poplar; beech, ash, and firs, he says, are ruinous to fences and otherwise injurious to farmers. (*On Hedges and Hedge-row Timber*, p. 10.)

SECT. III. *Of forming Plantations.*

3642. *The formation of plantations* includes enclosing, preparation of the soil, and mode of planting or sowing.

3643. *The enclosing of plantations* is too essential a part of their formation to require enlarging on. In all those of small extent, as hedges and strips, it is the principal part of the expense; but to plant in these forms, or any other, without enclosing, would be merely a waste of labor and property. The sole object of fencing being to exclude the domestic quadrupeds, it is obvious, that whatever in the given situation is calculated to effect this at the least expense, the first cost and future repairs or management being taken into consideration, must be the best. Where stones abound on the spot, a wall is the best and cheapest of all fences as such; but, in the great majority of cases, recourse is obliged to be had to a verdant fence of some sort, and generally to one of hawthorn. This being itself a plantation, requires to be defended by some temporary barrier, till it arrives at maturity; and here the remark just made will again apply, that whatever temporary barrier is found cheapest in the given situation will be the best. Hedge fences are in general accompanied by an open drain, which, besides acting in its proper capacity, furnishes at its formation a quantity of soil to increase the pasturage of the hedge plants; an excavation

*(fig. 454 a)*, and an elevation *(f)*, to aid in the formation of a temporary fence. A hedge enclosing a plantation, requires only to be guarded on the exterior side, and of the various ways in which this is done, the following may be reckoned among the best and most generally applicable: by an open drain and paling, or line of posts and rails *(a)*, the plants inserted in a facing of stone, backed by the earth of the drain *(b)*; an excellent mode, as the plants generally thrive, and almost never require cleaning from weeds; an open drain and paling, and the hedge on the top of the elevation *(c)*; no open drain, but the soil being a loam, the surface-turves formed into a narrow ridge, to serve as a paling, a temporary hedge of furze sown on its summit, and the permanent hedge of thorn or holly within *(d)*; and an open drain, but on the inside, the exterior being protected by a steep bank sown with furze *(e)*. The first of these modes is the most general, the second the best, and the fourth the cheapest, where timber is not abundant. Separation fences are commonly formed in the first, second, or third manner, but with a paling on both sides.



3644. *In the preparation of the soil* for planting, draining is the first operation. Whatever may be the nature of the soil, if the plants are intended to thrive, the subsoil ought to be rendered dry. Large open drains may be used, where the ground is not to undergo much preparation; but where it is to be fallowed or trenched, under drains become requisite. It is true they will in time be choked up by the roots of the trees; but by that period, as no more culture will be required, they may be opened and left open. Many situations, as steep sides of hills and rocky irregular surfaces, do not admit of preparing the soil by comminution previously to planting; but wherever that can be done, either by

trenching, digging, or a year's subjection to the plough, it will be found amply to repay the trouble. This is more especially requisite for strips, for shelters or hedge-rows, as the quick growth of the plants in these cases is a matter of the utmost consequence. The general mode of planting hedges by the side of an open drain, renders preparation for them, in many cases, less necessary; but for strips of trees, wherever it is practicable, and there is at the same time no danger of the soil being washed away by rains or thaws, as in some chalky hilly districts; or blown about by the wind, as in some parts of Norfolk, and other sandy tracts, preparation by a year's fallow, or by trenching two spits deep, cannot be omitted without real loss, by retarding the attainment of the object desired. There are instances stated, of promising oak plantations, from oaks dibbed into soil altogether unimproved, and of plantations of Scotch pine, raised by merely sowing the seeds on a heath or common, and excluding cattle (*General Report of Scotland*, ii. 269.); but these are rare cases, and the time required and the instances of failure are not mentioned. The practice is obviously too rude to be recommended as one of art. The best situations for planting, without any other culture but inserting the seeds or plants, are surfaces partially covered with low woody growths, as broom, furze, &c. "The ground which is covered, or rather half covered, with juniper and heath," says Buffon, "is already a wood half made. Osier plantations are an exception to these remarks, as to the value of the situation and soil; they require a deep, strong, moist soil, but one not springy, or continually saturated with water; and it will be in vain to plant them without draining and trenching it two or more feet deep."

3645. *Whether extensive plantations should be sown or planted*, is a question about which planters are at variance. Miller says, transplanted oaks will never arrive at the size of those raised where they are to remain from the acorn. (*Dict. Quercus.*) Marshal prefers sowing when the ground can be cultivated with the plough. (*Plant. and Rur. Orn.* i. 123.) Evelyn, Emmerich, and Speechly are of the same opinion; Pontey and Nicol practice planting, but offer no arguments against sowing where circumstances are suitable. Sang says, "It is an opinion very generally entertained, that planted timber can never, in any case, be equal in durability and value to that which is sown. We certainly feel ourselves inclined to support this opinion, although we readily admit, that the matter has not been so fully established, from experiment, as to amount to positive proof. But although we have not met with decided evidence, to enable us to determine on the comparative excellence of timber raised from seeds, without being replanted, over such as have been raised from replanted trees, we are left in no doubt as to the preference, in respect of growth, of those trees which are sown, over such as are planted." (*Plant. Kal.* 43.) He particularly prefers this mode for raising extensive tracts of the Scotch pine and larch (p. 430.), and is decidedly of opinion, "that every kind of forest tree will succeed better by being reared from seeds in the place where it is to grow to maturity, than by being raised in any nursery whatever, and from thence transplanted into the forest." (p. 344.) Dr. Yule (*Caled. Hort. Mem.* ii.), in a long paper on trees, strongly recommends sowing where the trees are finally to remain. "It is," says he, "a well ascertained fact, that seedlings allowed to remain in their original station, will, in a few seasons, far overtop the common nursed plants several years older."

3646. *The opinion of Dr. Yule, and in part also that of Sang*, seems to be founded on the idea that the tap-root is of great importance to grown-up trees, and that when this is once cut off by transplanting, the plant has not a power of renewing it. That the tap-root is of the utmost consequence for the first three or four years is obvious from the economy of nature at that age of the plant; perhaps for a longer period; but that it can be of no great consequence to full-grown trees, appears highly probable from the fact, that when such trees are cut down, the tap-root is seldom to be distinguished from the others. The opinion that young plants have not the power of renewing their tap-root, will, we believe, be found inconsistent with fact; and we may appeal to Sang and other nurserymen, who raise the oak and horse-chestnut from seed. It is customary when these are sown in drills, to cut off their tap-roots without removing the plants at the end of the second year's growth, and when at the end of the third or fourth year they are taken up, they will be found to have acquired other tap roots, not indeed so strong as the first would have been had they remained, but sufficient to establish the fact of the power of renewal. We may also refer to the experiment recorded by Forsyth, which at once proves that trees have a power of renewing their tap-roots, and the great advantages from cutting down trees after two or three years' planting. Forsyth "transplanted a bed of oak-plants, cutting the tap-roots near to some of the side-roots or fibres springing from them. In the second year after, he headed one half of the plants down, and left the other half to nature. In the first season, those headed down made shoots six feet long and upwards, and completely covered the head of the old stem, leaving only a faint cicatrix, and produced new tap-roots upwards of two feet and a half long. That half of the plants that were not headed, were not one fourth the size of the others. One of the former is now eighteen feet high, and fifteen inches in circumference, at six inches from the ground: one of the largest of the



latter measures only five feet and a half in height, and three inches and three quarters in circumference, at six inches from the ground." (*Tr. on Fruit Trees*, 4to edit. 144.) The pine and fir tribes receive most check by transplanting; and when removed at the age of four or five years, they seldom arrive at trees afterwards; those we should, on most occasions, prefer to sow, especially upon mountainous tracts. But for all trees which stole, and in tolerable soils and situations, planting strong plants, and cutting them down two or three years afterwards, will, we think, all circumstances considered, be found preferable to sowing.

3647. *On the subject of disposing the plants in plantations, there are different opinions; some advising rows, others quincunx, but the greater number planting irregularly.* According to Marshal, "the preference to be given to the row, or the random culture, rests in some measure upon the nature and situation of the land to be stocked with plants. Against steep hangs, where the plough cannot be conveniently used in cleaning and cultivating the interspaces, during the infancy of the wood, either method may be adopted; and if plants are to be put in, the quincunx manner will be found preferable to any. But in more level situations, we cannot allow any liberty of choice: the drill or row manner is undoubtedly the most eligible." (*Plant. and Rur. Orn.* p. 123.) Pontey considers it of much less consequence than most people imagine, whether trees are planted regularly or irregularly, as in either case the whole of the soil will be occupied by the roots and the surface by the shoots. Sang and Nicol only plant in rows where culture with the horse-hoe is to be adopted. In sowing for woods and copses, the former places the patches six feet asunder and in the quincunx order. "It has been demonstrated (*Farmer's Mag.* vii. 409.) that the closest order in which it is possible to place a number of points, upon a plain surface, not nearer than a given distance from each other, is in the angles of hexagons with a plant in the centre of each hexagon." Hence it is argued, that this order of trees is the most economical; as the same quantity of ground will contain a greater quantity of trees, by 15 per cent. when planted in this form than in any other. (*Gen. Rep.* ii. 287.) It is almost needless to observe, that hedge plants should be placed at regular distances in the lines, and also the trees, when those are introduced in hedges. Osier plantations, and all such as like them require the soil to be dug every year, or every two years, during their existence, should also be planted in regular rows.

3648. *The distances at which the plants are placed must depend on different circumstances, but chiefly on the situation and soil.* Planting thick, according to Nicol, is the safer side to err on, because a number of plants will fail, and the superfluous ones can be easily removed by thinning. "For bleak situations," he observes, "that from thirty to forty inches is a good medium, varying the distance according to circumstances. For less exposed situations, and where the soil is above six inches in depth, he recommends a distance from four to five feet. For belts, clumps, and strips of a diameter of about one hundred feet; the margin to be planted about the distance of two feet, and the interior at three feet. In sheltered situations of a deep good soil, he recommends a distance of six feet, and no more." (*Pract. Plant.*)

3649. *According to Sang, "the distances at which hard-timber trees ought to be planted are from six to ten feet, according to the quality of the soil, and the exposed or sheltered situation.* When the first four oaks are planted, supposing them at right angles, and at nine feet apart, the interstices will fall to be filled up with five nurses, the whole standing at four and a half feet asunder. When sixteen oaks are planted, there will necessarily be thirty-three nurses planted; and when thirty-six oaks are planted, eighty-five nurses; but when a hundred principal trees are planted in this manner, in a square of ten on the side, there will be two hundred and sixty-one nurse-plants required. The English acre would require five hundred and thirty-six oaks, and one thousand six hundred and ten nurses." (*Plant. Kal.* 163.) Pontey says, "in general cases, a distance of four feet is certainly close enough; as at that space the trees may all remain till they become saleable as rails, spars, &c."

3650. *The number of plants which may be planted on a statute acre = 160 rods, or poles, = 4840 yards = 43,560 feet, is as follows:—*

Feet apart.	No. of Plants.	Feet apart.	No. of Plants.	Feet apart.	No. of Plants.
1	43,560	6	1,210	15	193
1½	19,360	7	889	16	170
2	10,890	8	680	17	150
2½	6,969	9	537	18	134
3	4,840	10	435	19	120
3½	3,556	11	360	20	108
4	2,722	12	302	25	69
4½	2,232	13	257	30	48
5	1,742	14	222		

3651. *The size of the plants depends jointly on the site and the kind of tree; it is universally allowed that none of the resinous tribe succeed well when removed at four or more years' growth; but if the soil is of tolerable quality, prepared by digging or sum-*

mer pitting, and the site not bleak, plants of such hard woods as stole may be used whose stems are an inch or more in diameter.

3652. *Nicol* is of opinion, "That generally trees three, or at most four years old from the seed, and which are from twelve to twenty-four inches high, will, in any situation or soil, outgrow those of any size under eight or ten feet, within the seventh year." (*Pract. Plant.* 130.)

3653. *Sang* observes, "The size of plants for exclusive plantations must, in some measure, depend on their kinds; but it may be said, generally, that the plants being transplanted, they should be from a foot to eighteen inches in height, stiff in the stem and well rooted. Plants for this purpose should seldom be more than three years from the seed; indeed never, if they have been raised in good soil. Many of them may be sufficiently large at two years from the seed; and if so, are to be preferred to those of a greater age, as they will consequently be more vigorous and healthy. The larch, if properly treated, will be very fit for planting out at two years of age. A healthy seedling being removed from the seed-bed at the end of the first year, into good ground, will, by the end of the second, be a fitter plant for the forest, than one nursed a second year. The next best plant for the purpose, is that which has stood two years in the seed-bed, and has been transplanted for one season. This is supposing it to have risen a weakly plant; for, if the larch rise strong from the seed the first season, it should never stand a second in the seed-bed. The ash, the elm, and the sycamore, one year from the seed, nursed in good soil for a second season, will often prove sufficiently strong plants. If they be weakly, they may stand two years in the seed-bed; and then being nursed one season in good soil, will be very fit for planting out in the forest. The oak, the beech, and the chestnut, if raised in rich soil, and well furnished with roots at the end of the first year, and having been nursed in rows for two years, will be very fit to be planted out. But if they be allowed to stand two years in the seed-bed, and be planted one year in good ground, they will be still better, and the roots will be found well feathered with fine small fibres. The silver fir and common spruce should stand two years in the seed-bed. If transplanted into very good soil, they may be fit for being planted out at the end of the first year; but, more generally, they require two years in the lines. The Scots pine should also stand for two years in the seed-bed, and should be nursed in good ground for one year; at the end of which they will be much fitter for being planted, than if they were allowed to stand a second year in the lines. They are very generally taken at once from the seed-bed; and in land bare of heath or herbage, they succeed pretty well; nevertheless, we would prefer them one year nursed. The above are the hardy and most useful forest trees; and from the observations made, whatever respects the age or size of other kinds, may easily be inferred." (*Plant. Kal.* 158.)

3654. *According to Pontey*, "the best general rule is, to proportion the size of the plants to the goodness of the soil; the best of the latter requiring the largest of the former. Still on bleak exposures this rule will not hold good, as there the plants should never be large, for otherwise the greater part would fail from the circumstance of wind-waving, and of those that succeeded, few, if any, would make much progress for several years; firs of a foot, and deciduous trees of eighteen inches, are large enough for such places. As in extensive planting, soils which are good and well sheltered but seldom occur, the most useful sizes of plants, for general purposes, will be firs of a foot, and deciduous trees of eighteen inches, both transplanted. None but good-rooted plants will succeed on a bad soil, while on a good one, sheltered, none but very bad-rooted plants will fail; a large plant never has so good a root, in proportion to its size, as a small one; and hence we see the propriety of using such on good soils only. Small plants lose but few of their roots in removal; therefore, though planted in very moderate-sized holes of pulverised earth, they soon find the means of making roots, in proportion to their heads. It should never be forgotten, that, in being removed, a plant of two feet loses a greater proportion of its roots than a tree of one, and one of three feet a greater proportion than one of two, and so on, in proportion to its former strength and height, and thus the larger the plants, so much greater is the degree of languor or weakness into which they are thrown by the operation of transplanting." (*Prof. Plant.* 161.)

3655. *The seasons for planting* are autumn and spring; the former when the soil and situation are moderately good, and the plants large; and the latter, for bleak situations. Necessity, however, is more frequently the guide here than choice, and in extensive designs, the operation is generally performed in all moderately dry open weather from October to April inclusive. "In an extensive plantation," *Sang* observes, "it will hardly happen but there will be variety of soil, some parts moist and heavy, and others dry and light. The lightest parts may be planted in December or January; and the more moist, or damp parts, in February or March. It must be observed, however, that if the ground be not in a proper case for planting, the operation had better be delayed. The plants will be injured, either by being committed to the ground when it is in a sour and wet, or in a dry parched state. At a time when the soil is neither wet nor dry,

the operation of planting is most successfully performed. The mould does not then adhere to the spade, nor does it run in; it divides well, and is made to intermingle with the fibres of the plants with little trouble; and in treading and setting the plant upright, the soil is not worked into mortar, which it necessarily must be, if in a wet state, evidently to the great detriment of the plants. It is therefore improper to plant on a retentive soil in the time of rain, or even perhaps for some days afterwards, or after a fall of snow, until it has for some days disappeared. Whereas, on a dry absorbent soil, it may be proper to plant in the time of gentle showers, immediately after heavy rains, or as soon as the snow is dissolved." (*Plant. Kal.* 157.)

3656. *Pontey* is a decided advocate for autumn preparation of the soil, and spring planting. "Autumn planting," he says, "is advisable only in few cases, while spring planting may properly apply to all."

3657. *According to Sang*, the proper time for planting the pine and fir tribes, and all evergreens, is April, or even the first fortnight in May. "Attention should be paid, that no greater number of plants be lifted from the nursery than can be conveniently planted on the same day. Damp weather is the best. When very dry, and the plants rise destitute of earth at their roots, their roots should be dipped in mud (puddle) so as to be coated over by it. In all cases, care should be taken not to shake off any adhering earth from plants at the time of planting." (*Plant. Kal.* 341.)

3658. *The operation of inserting the plants in the soil* is performed in various ways; the most general mode, and that recommended by *Marshal and Nicol*, is pitting; in which two persons are employed, one to operate on the soil with the spade, and the other to insert the plant and hold it till the earth is put round it, and then press down the soil with the foot. Where the plants are three feet high or upwards, this is the best mode; but for smaller plants modes have been adopted in which one person performs the whole operation.

3659. *Sang* describes five kinds of manual operation employed by him in planting, and in part in sowing-trees: by pitting; by slitting simply, or by cross, or T slitting; by the diamond dibber; by the planting-mattock; and by the planter. In filling an area with plants, he first plants those intended as the final trees, and afterwards the nurses; or one set of operators plant the former, while another follow with the latter, unless the time for removing the nurses, as in the case of evergreen pines and firs, should be later than that for planting the principals. "The plants, if brought from a distance, should be *shoughed*, i.e. *earthed*; or they may be supplied daily from the nursery, as circumstances direct. All the people employed ought to be provided with thick aprons, in which to lap up the plants; the spadesmen, as well as the boys or girls; the latter being supplied by the former as occasion may require. All of them should regularly fill their aprons at one time, to prevent any of the plants being too long retained in any of the planters' aprons. One man cannot possibly set a plant so well with the spade, unless in the case of *laying*, as two people can; nor, supposing him to do it as well, can he plant half as many in the same space of time as two can. A boy ten years of age is equal, as a holder, to the best man on the field, and can be generally had for less than half the money. Hence this method is not only the best, but the least expensive." (*Plant. Kal.* 167.)

3660. *By pitting*. "The pit having been dug for several months, the surface will therefore be encrusted by the rains, or probably covered with weeds. The man first strikes the spade downwards to the bottom, two or three times, in order to loosen the soil; then poaches it as if mixing mortar for the builder; he next lifts out a spadeful of the earth, or, if necessary, two spadefull, so as to make room for all the fibres, without their being anywise crowded together; he then chops the rotten turf remaining in the bottom, and levels the whole. The boy now places the plant perfectly upright, an inch deeper than when it stood in the nursery, and holds it firm in that position. The man *trindles* in the mould gently; the boy gently moves the plant, not from side to side, but upwards and downwards, until the fibres be covered. The man then fills in all the remaining mould; and immediately proceeds to chop and poach the next pit, leaving the boy to set the plant upright, and to tread the mould about it. This in stiff wet soil he does lightly; but in sandy or gravelly soil he continues to tread until the soil no longer retains the impression of his foot. The man has by this time got the pit ready for the next plant, the boy is also ready with it in his hand, and in this manner the operation goes on. On very steep *hangs* which have been pitted, the following rule ought to be observed in planting; to place the plant in the angle formed by the acclivity and surface of the pit; and in finishing to raise the outer margin of the pit highest, whereby the plant will be made to stand as if on level ground, and the moisture be retained in the hollow of the angle, evidently to its advantage." (*Plant. Kal.* 167.)

3661. *The slit method*, either simply or by the T method, is not recommended by *Sang*; but necessity may justify its adoption occasionally. "We would not recommend planting by the slit, unless where there is no more soil than is absolutely occupied by the fibres

of the herbage which grows on the place. Excepting on turf, it cannot be performed; nor should it be practised, if the turf be found three or four inches thick. By pitting in summer, turf is capable of being converted into a proper mould in the space of a few months; and the expense of pitting, especially in small plantations, can never counter-balance the risk of success in the eyes of an ardent planter. The most proper time to perform the operation of slitting in the plants, is when the surface is in a moist state. On all steeps the plant should be placed towards the declivity, that the moisture may fall to its roots; that is to say, in planting, the spadesman should stand highest, and the boy lowest on the bank; by which arrangement the plant will be inserted at the lower angle of the slit." (*Plant. Kal.* 170.)

3662. *Planting with the diamond dibber*, he says, "is the cheapest and most expeditious planting of any we yet know, in cases where the soil is a sand or gravel, and the surface bare of herbage. The plate of the dibber (*fig. 455 a*) is made of good steel, and is four inches and a half broad where the iron handle is welded to it; each of the other two sides of the triangle is five inches long; the thickness of the plate is one fifth part of an inch, made thinner from the middle to the sides, till the edges become sharp. The length of the iron handle is seven inches, and so strong as not to bend in working, which will require six-eighths of an inch square. The iron handle is furnished with a turned hilt, like the handle of a large gimlet, both in its form and manner of being fixed on. The planter is furnished with a planting bag, tied round his waist, in which he carries the plants. A stroke is given with the dibber, a little aslant, the point lying inwards; the handle of the dibber is then drawn towards the person, while its plate remains within the ground: by this means a vacuity is formed between the back of the dibber and the ground; into which the planter, with his other hand, introduces the roots of the seedling plants, being careful to put them fully to the bottom of the opening: he then pulls out the dibber, so as not to displace them, and gives the eased turf a smart stroke with the heel; and thus is the plant completely firmed. The greatest error the planter with this instrument can run into, is the imperfect introduction of the roots. Green, or unpractised hands, are apt to double the roots, or sometimes to lay them across the opening, instead of putting them straight down, as above directed. A careful man, however, will become, if not a speedy, at least a good planter in one day; and it is of more importance that he be a sure hand, than a quick one. A person who is of a careless or slovenly disposition, should never be allowed to handle a dibber of this kind."

3663. *Planting with the planting-mattock* (*fig. 455 b*) is resorted to in rocky or other spots where pitting is impracticable. "The helve or handle is three feet six inches long; the mouth is five inches broad, and is made sharp; the length from it to the eye, or helve, is sixteen inches; and it is used to pare off the sward, heath, or other brush that may happen to be in the way, previous to easing the soil with the other end. The small end tapers from the eye, and terminates in a point, and is seventeen inches long." By this instrument the surface is skimmed off "for six or eight inches in diameter, and with the pick-end dug down six or eight inches deep, bringing up any loose stones to the surface; by which means a place will be prepared for the reception of the plant, little inferior to a pit. This instrument may be used in many cases, when the plants to be planted are of small size, such as one-year larch-seedlings, one year nursed; or two-year Scots pines, one year nursed; and the expense is much less than by the spade." (*Plant. Kal.* 385.)

3664. *Planting with the forest-planter* (*fig. 455 c*). "The helve is sixteen inches long, the mouth is four inches and a half broad, and the length of the head is fourteen inches. The instrument is used in planting hilly ground, previously prepared by the hand-mattock. The person who performs the work carries the plants in a close apron; digs out the earth sufficiently to hold the roots of the plant; and sets and firms it without help from another: it is only useful when small plants are used, and in hilly or rocky situations." (*Plant. Kal.* *pref.* xxiv.)

3665. *Pontey prefers planting by pitting*, in general cases; the holes being made during the preceding summer or winter, sufficiently large, but not so deep into a retentive subsoil as to render them a receptacle for water. When the plants have been brought from a distance he strongly recommends puddling them previously to planting; if they seem very much dried, it would be still better to lay them in the ground for eight or ten days, giving them a good soaking of water every second or third day, in order to

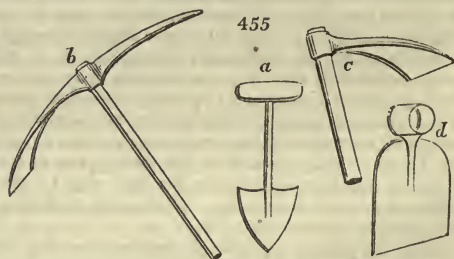

restore their vegetable powers; for it well deserves notice, that a degree of moisture in soil sufficient to support a plant recently or immediately taken from the nursery, would, in the case of dry ones, prove so far insufficient, that most of them would die in it. The puddling here recommended may also be of great service in all cases of late planting where small plants are used; Pontey's method is (after puddling) to tie them in bundles, of two or three hundreds each; and thus send them, by a cart-load at once, to where wanted; where such bundles being set upright, close to each other, and a little straw carefully applied to the outsides of them, may remain without damage in a sheltered situation any reasonable time necessary to plant them. Where loose soil happens to be convenient, that should be substituted in the place of straw.

3666. *A puddle for trees* is made by mixing water with any soil rather tenacious, so intimately as to form a complete puddle, so thick that when the plants are dipped into it, enough may remain upon the roots to cover them. The process of puddling is certainly simple, and its expense too trifling to deserve notice: its effects, however, in retaining, if not attracting moisture, are such that, by means of it, late planting is rendered abundantly more safe than it otherwise would be. It is an old invention, and hence it is truly astonishing that it is not more frequently practised. If people were to adopt it generally in spring planting, Pontey believes the prejudice in favor of autumn practice would soon be done away. (*Prof. Plant.* 167.)

3667. *Pontey's methods of planting* are in general the same as those of Sang: he uses a mattock and planter of similar shape; and also a two or three pronged instrument, which we have elsewhere denominated the *planter's hack*. (*Encyc. of Gard.* § 1305.) "This instrument," he says, "has been introduced of late years as an improvement on the mattock and planter, being better adapted to soils full of roots, stones, &c.; it is likewise easier to work, as it penetrates to an equal depth with a stroke less violent than the former: it is also less subject to be clogged up by a wet or tenacious soil. The length of the prongs should be about eight inches, and the distances between them, when with three prongs, one and a half, and with two prongs, about two inches; the two-pronged hack should be made somewhat stronger than the other, it being chiefly intended for very stony lands, or where the soil wants breaking, in order to separate it from the herbage, &c. These tools are chiefly applicable to plants of any size up to about two feet, or such as are generally used for great designs, where they are used as a substitute for the spade, in the following manner: The planter being provided with a basket holding the plants required (the holes being supposed prepared, and the earth left in them), he takes a tree in one hand, and the tool in the other, which he strikes into the hole, and then pulls the earth towards him, so as to make a hole large enough to hold all its roots; he then puts in the plant with the other, and pushes the earth to its roots with the back of the planter; after which, he fixes the plant, and levels the soil at the same instant with his foot: so that the operation is performed by one person, with a degree of neatness and expedition which no one can attain to who uses the spade. It is known to all planters, that but few laborers ever learn to plant well and expeditiously in the common method, without an assistant: this method, however, requires neither help nor dexterity; as any laborer of common sagacity, or boy of fifteen, or even a woman, may learn to perform it well in less than half an hour. The facility with which these tools will break clods, clear the holes of stones, or separate the soil from herbage, the roots of heath, &c. (the former being previously mellowed by the frost), may be easily imagined." (*Prof. Plant.* 173.) The adoption of a small mattock for inserting plants, we recollect to have seen recommended in a tract on planting in the Highlands, by M'Laurin, a nurseryman, published at Edinburgh upwards of twenty years ago.

3668. *An expeditious mode of slit planting* is described in the *General Report of Scotland*, as having been practised for many years on the duke of Montrose's estate. It is as follows: "The operator, with his spade, makes three cuts, twelve or fifteen inches long, crossing each other in the centre, at an angle of sixty degrees, the whole having the form of a star. (*fig.* 456.) He inserts his spade across one of the rays (*a*), a few inches from the centre, and on the side next himself; then bending the handle towards himself, and almost to the ground, the earth opening in fissures from the centre in the direction of the cuts which had been made, he, at the same instant, inserts his plant at the point where the spade intersected the ray (*a*), pushing it forward to the centre, and assisting the roots in rambling through the fissures. He then lets down the earth by removing his spade, having pressed it into a compact state with his heel; the operation is finished by adding a little earth, with the grass side down, completely covering the fissures, for the purpose of retaining the moisture at the root, and likewise as a top-dressing, which greatly encourages the plant to push fresh roots between the swards." (*Vol.* ii. p. 283.)



SECT. IV. *Of the Mixture of Trees in Plantations.*

3669. *The object of mixing trees in plantations* is threefold: that of sheltering the weaker but ultimately more valuable kinds by the stronger and hardier; that of drawing as much profit from the soil as possible; and that of producing variety of appearance.

3670. With respect to *shelter* many situations are so exposed, that it is extremely difficult to rear trees without some mode of protecting them from the cold winds of spring during their early growth. This is sometimes done by walls, the extent of whose influence, however, is but very limited; by thick planting, or by planting the more hardy and rapid growing species, to nurse up and protect such as are more tender, but ultimately more valuable. The proportion of nurses to principals is increased according to the bleakness of the site: Pontey says, "Both authors and planters are in the habit of erring egregiously, in regard to the proportion of principals and nurses, as they generally use as many or more of the former than the latter, though it is very easy to show, that they ought to use three times as many of the latter as the former. For instance, when trees are planted at four feet apart, each occupies a surface of sixteen feet; of course four of them will occupy sixty-four, or a square of eight feet; and, therefore, if we plant three nurses to one principal tree, all the former might be displaced gradually, and the latter would still stand only eight feet apart.

3671. *Nurse plants* should, in every possible case, be such as are most valued at an early period of growth. The larch and spruce fir should be used liberally, in every case where they will grow freely; still it is not intended they should exclude all others, more particularly the birch, which has most of the properties of a good nurse, such as numerous branches and quick growth, on any tolerable soil or situation. It is not, however, like the others, a wood of general application. (*Profitable Planter*, p. 113.) Sang also adopts the proportion of three nurses to one principal, and employs chiefly the resinous tribe, and looks to them for reimbursement till the hard timber has attained to a foot in diameter, under which size hard timber is seldom of much value. His principals are planted at from six to ten feet apart, according to the soil and situation. (*Plant. Kal.* p. 166.)

3672. *In procuring shelter much depends on the mode of commencing and continuing plantations on bleak sites.* Sang, who has had extensive experience in this part of planting, observes, that "every plain, and most fields and situations for planting, in this country, have what may be called a windward side, which is more exposed to the destructive blast than any other. It is of great importance to be apprised of this circumstance, and to be able to fix upon the most exposed side of the proposed forest plantation. Fix, then, upon the windward side of the space which is to be converted into a forest, mark off a horizontal stripe or belt, at least a hundred yards in breadth. Let this portion of ground be planted thick, say at the distance of thirty inches, or at the most three feet, with a mixture of larch, sycamore, and elder, in equal quantities or nearly so, if the soil be adapted for rearing these; but if it be better adapted for Scots pines, then let it be planted with them at the distances prescribed for the above mixture. We have no other kinds that will thrive better, or rise more quickly in bleak situations, than those just mentioned. When the trees in this belt or zone have risen to the height of two feet, such hard-wood trees as are intended ultimately to fill the ground should be introduced, at the distance of eight or ten feet from each other, as circumstances may admit. At this period, or perhaps a year or two afterwards, according to the bleak or exposed situation of the grounds, let another parallel belt or zone, of nearly equal breadth, be added to the one already so far grown up, and so on, till the whole grounds be covered. It is not easy here to determine on the exact breadth of the subsequent belt or zones; this matter must be regulated by the degree of exposure of the grounds, by the shelter afforded by the zone previously planted, and by such like circumstances." (*Plant. Kal.* p. 29.)

3673. *In situations exposed to the sea breeze a similar plan* may be successfully followed, and aided in effect, by beginning with a wall; the first zone having reached the height of the wall, plant a second, a third, and fourth, and so on till you cover the whole tract to be wooded. In this way the plantations on the east coast of Mid Lothian, round Gosford-house, were reared; in Sang's manner, the mountains of Blair and Dunkeld were clothed; and examples, we are informed, might be drawn from the Orkney and Shetland islands.

3674. *The practice of mixing trees* with a view of drawing as much nourishment from the soil as possible, and giving, as it used to be said, more chances of success, was till very lately generally approved of. Marshal advises mixing the ash with the oak, because the latter draws its nourishment chiefly from the subsoil, and the former from the surface. Nicol is an advocate for indiscriminate mixture (*Practical Planter*, p. 77.), and Pontey says, "both reason and experience will fully warrant the conclusion, that the greatest possible quantity of timber is to be obtained by planting mixtures." (*Prof. Planter*, p. 119.) "We are clearly of opinion," says Sang, "that the best method is

to plant each sort in distinct masses or groups, provided the situation and quality of the soil be properly kept in view. There has hitherto been too much random work carried on with respect to the mixture of different kinds. A longer practice, and more experience, will discover better methods in any science. That of planting is now widely extended, and improvements in all its branches are introduced. We, therefore, having a better knowledge of soils, perhaps, than our forefathers had, can with greater certainty assign to each tree its proper station. We can, perhaps, at sight, decide that here the oak will grow to perfection, there the ash, and here again the beech; and the same with respect to the others. If, however, there happen to be a piece of land of such a quality, that it may be said to be equally adapted for the oak, the walnut, or the Spanish chestnut, it will be proper to place such in it, in a mixed way as the principals; because each sort will extract its own proper nourishment, and will have an enlarged range of pasturage for its roots, and consequently may make better timber trees.

3675. *By indiscriminately mixing* different kinds of hard-wood plants in a plantation, there is hardly a doubt that the ground will be fully cropped with one kind or other; yet it very often happens, in cases when the soil is evidently well adapted to the most valuable sorts, as the oak perhaps, that there is hardly one oak in the ground for a hundred that ought to have been planted. We have known this imperfection in several instances severely felt. It not unfrequently happens, too, that even what oaks or other hard-wood trees are to be met with, are overtopped by less valuable kinds, or perhaps such, all things considered, as hardly deserve a place. Such evils may be prevented by planting with attention to the soil, and in distinct masses. In these masses are insured a full crop, by being properly nursed for a time with kinds more hardy, or which afford more shelter than such hard-wood plants. There is no rule by which to fix the size or extent of any of these masses. Indeed, the more various they are made in size, the better will they, when grown up, please the eye of a person of taste. They may be extended from one acre to fifty, or a hundred acres, according to the circumstances of soil and situation: their shapes will accordingly be as various as their dimensions. In the same manner ought all the resinous kinds to be planted, which are intended for timber trees; nor should these be intermixed with any other sort, but be in distinct masses by themselves. The massing of larch, the pine, and the fir of all sorts, is the least laborious and surest means of good, straight, and clean timber. It is by planting, or rather by sowing them in masses, by placing them thick, by a timely pruning and gradual thinning, that we can with certainty attain to this object." (*Plant. Kal.* 162 and 166.) Our opinion is in perfect consonance with that of Sang, and for the same reasons; and we may add as an additional one, that in the most vigorous natural forests one species of tree will generally be found occupying almost exclusively one soil and situation, while in forests less vigorous on inferior and watery soils, mixtures of sorts are more prevalent. This may be observed by comparing New Forest with the natural woods round Lochlomond, and it is very strikingly exemplified in the great forests of Poland and Russia.

3676. *With respect to the appearance of variety*, supposed to be produced by mixing a number of species of trees together in the same plantation, we deny that variety is produced. Wherever there is variety there must be some marked feature in one place, to distinguish it from another; but in a mixed plantation the appearance is every where the same; and ten square yards at any one part of it, will give nearly the same number and kind of trees as ten square yards at any other part. "There is more variety," Repton observes, "in passing from a grove of oaks to a grove of firs, than in passing through a wood composed of a hundred different species, as they are usually mixed together. By this indiscriminate mixture of every kind of tree in planting, all variety is destroyed by the excess of variety, whether it is adopted in belts, clumps, or more extensive masses. For example, if ten clumps be composed of ten different sorts of trees in each, they become so many things exactly similar; but if each clump consists of the same sort of trees, they become ten different things, of which one may hereafter furnish a group of oaks, another of elms, another of chestnuts, or of thorns, &c. In like manner, in the modern belt, the recurrence and monotony of the same mixture of trees of all the different kinds, through a long drive, make it the more tedious, in proportion as it is long. In part of the drive at Woburn, evergreens alone prevail, which is a circumstance of grandeur, of variety, of novelty, and, I may add, of winter comfort, that I never saw adopted in any other place, on so magnificent a scale. The contrast of passing from a wood of deciduous trees to a wood of evergreens, must be felt by the most heedless observer; and the same sort of pleasure, though in a weaker degree, would be felt, in the course of a drive, if the trees of different kinds were collected in small groups or masses by themselves, instead of being blended indiscriminately." (*Enquiry into Changes of Taste, &c.* p. 23.)

3677. *Sir William Chambers, and Price*, agree in recommending the imitation of natural forests in the arrangement of the species. In these, nature disseminates her plants by scattering their seeds, and the offspring rise round the parent in masses or

breadths, depending on a variety of circumstances, but chiefly on the facility which these seeds afford for being carried to a distance by the wind, the rain, and by birds or other animals. At last that species which had enjoyed a maximum of natural advantages is found to prevail as far as this maximum extended, stretching along in masses and irregular portions of surface, till circumstances changing in favor of some other species, that takes the precedence in its turn. In this way it will be generally found, that the number of species, and the extent and style of the masses in which they prevail, bears a strict analogy to the changes of soil and surface; and this holds good, not only with respect to trees and shrubs, but to plants, grasses, and even the mossy tribe.

#### SECT. V. *Of the Culture of Plantations.*

3678. *Most men consider a tree when once planted, as done with; though, as every one knows, the progress and products of trees, like those of other plants, may be greatly increased or modified by cultivating the soil, pruning, and thinning.*

##### SUBJECT. 1. *Of the Culture of the Soil among Trees.*

3679. *With respect to the culture of the soil, it is evident, that young plantations should be kept clear of such weeds as have a tendency to smother the plants; and though this is not likely to take place on heaths and barren sites, yet even these should be looked over once or twice during summer, and at least those weeds removed which are conspicuously injurious. In grounds which have been prepared previously to planting, weeding, hoeing by hand, or by the horse hoe, and digging or ploughing, become necessary according to circumstances. The hoeings are performed in summer to destroy weeds, and render the soil pervious to the weather; the ploughing and diggings in winter are for the same purpose, and sometimes to prepare the soil for spring crops. These, both Pontey and Sang allow, may be occasionally introduced among newly-planted trees; though it must not be forgotten that relatively to the trees, the plants composing such crops are weeds, and some of them, as the potatoe, weeds of the most exhausting kind. Sang uses a hoe of larger size than usual (fig. 455 d.)*

3680. *In preparing lands for sowing woods, Sang ploughs in manure, sows in rows six feet apart, by which he is enabled to crop the ground between, with low growing early potatoes, turnips, and lettuce; but not with young trees as a sort of nursery, as they prove more scourging crops than esculent vegetables; nor with grain, as not admitting of culture, and being too exhausting for the soil. Marshal, and some other authors, however, approve of sowing the tree seeds with a crop of grain, and hoeing up the stubble and weeds when the crop is removed.*

3681. *Pontey observes, "that wherever preparing the soil for planting is thought necessary, that of cultivating it for some years afterwards, will generally be thought the same; slight crops of potatoes with short tops, or turnips, may be admitted into such plantations with advantage for two or three years, as they create a necessity for annually digging or stirring the surface, and tend very materially to accelerate the growth of the plants. It may be objected, that such crops must impoverish the soil, and no doubt but such is the fact, so far as common vegetables are concerned; but as to the production of wood, its support depends, in a great measure, on a different species of nutriment; and hence, I could never observe, that such cropping damaged it materially." (Profit. Plant. p. 153.)*

3682. *Osier plantations, for baskets, willows, and hoops, require digging and cleaning during the whole course of their existence; and so do hedge-rows to a certain extent, and some ornamental plantations.*

##### SUBJECT. 2. *Of the Filling up of Blanks or Failures in Plantations.*

3683. *Filling up blanks is one of the first operations that occurs on the culture of plantations next to the general culture of the soil, and the care of the external fences. According to Sang, "a forest plantation, either in the mass form or ordinary mixture, should remain several years after planting, before filling up the vacancies, by the death of the hard wood-plants, takes place. Hard-wood plants, in the first year, and even sometimes in the second year after planting, die down quite to the surface of the ground, and are apparently dead, while their roots, and the wood immediately above them, are quite fresh, and capable of producing very vigorous shoots, which they frequently do produce, if allowed to stand in their places. If a tree, such as that above alluded to, be taken out the first or second year after planting, and the place filled up with a fresh plant of the same kind, what happened to the former may probably happen to the latter; and so the period of raising a plant on the spot may be protracted to a great length of time; or it is possible this object may never be gained.*

3684. *The filling up of the hard-wood kinds in a plantation which has been planted after trenching, or summer fallow, and which has been kept clean by the hoe, may be done*



with safety at an earlier period than under the foregoing circumstances; because the trees, in the present case, have greater encouragement to grow vigorously after planting, and may be more easily ascertained to be entirely dead, than where the natural herbage is allowed to grow among them.

3685. *But the filling up of larches and pines* may take place the first spring after the plantation has been made; because such of these trees as have died are more easily distinguished. In many cases where a larch or pine loses its top, either by dying down, or the biting of hares or rabbits, the most vigorous lateral branch is elected by nature to supply the deficiency, which by degrees assumes the character of an original top. Pines, and larches, therefore, which have fresh lateral branches, are not to be displaced, although they have lost their tops. Indeed no tree in the forest, or other plantation, ought to be removed until there be no hope for its recovery.

3686. *If the filling up of plantations be left undone till the trees have risen to fifteen or twenty feet in height*, their roots are spread far abroad, and their tops occupy a considerable space. The introduction of two or three plants, from a foot to three feet in height, at a particular deficient place, can never, in the above circumstances, be attended with any advantage. Such plants may, indeed, become bushes, and may answer well enough in the character of underwood, but they will for ever remain unfit for any other purpose. It is highly improper then, to commence filling up of hard-wood plantations, before the third year after planting; or to protract it beyond the fifth or the sixth. March is the proper season for this operation. (*Plant. Kal.* 295.)

SUBJECT. 3. *Of Pruning and Heading Down Trees in Plantations.*

3687. *Pruning is the most important operation of tree culture*, since on it, in almost every case, depends the ultimate value, and in most cases, the actual bulk of timber produced. In the purposes of pruning, as for most other practicable purposes, the division of trees into resinous or frondose-branched trees, and into non-resinous or branchy-headed sorts is of use. The main object in pruning frondose-branched trees, is to produce a trunk with clean bark and sound timber; that in pruning branchy-stemmed trees, is principally to direct the ligneous matter of the tree into the main stem or trunk, and also to produce a clean stem and sound timber, as in the other case. The branches of frondose trees, unless in extraordinary cases, never acquire a timber size, but rot off from the bottom upwards, as the tree advances in height and age; and, therefore, whether pruned or not, the quantity of timber in the form of trunk is the same. The branches of the other division of trees, however, when left to spread out on every side, often acquire a timber-like size; and as the ligneous matter they contain is in general far from being so valuable as when produced in the form of a straight stem, the loss by not pruning off their side branches or preventing them from acquiring a timber-like size is evident. On the other hand, when they are broken off by accident, or rot off by being crowded together, the timber of the trunk, though in these cases increased in quantity, is rendered knotty and rotten in quality.

3688. With respect to the *manner of pruning*, Sang observes, "where straight timber is the object, both classes in their infancy should be feathered from the bottom upwards, keeping the tops light and spiral, something resembling a young larch (*fig.* 457 *a*). The proportion of their tops should be gradually diminished, year by year, till about their twentieth year, when they should occupy about a third part of the height of the plant; that is, if the tree be thirty feet high, the top should be ten feet (*b*). In all cases in pruning off the branches, the utmost care must be taken not to leave any stumps sticking out, but cut them into the quick. It is only by this means that clean timber can be procured for the joiner; or slightly stemmed trees to please the eye. It is a very general practice to leave snags or stumps (*c*); before the bole can be enlarged sufficiently to cover these, many years must elapse; the stumps in the meantime become rotten; and the consequence is, timber which when sawn up (*d*), is only fit for fuel."

3689. *Pontey* justly observes, "that the sap of a tree may be considered as the raw material furnished by nature; and man, the manufacturer who moulds it into the form most useful for his purpose. A moderate quantity

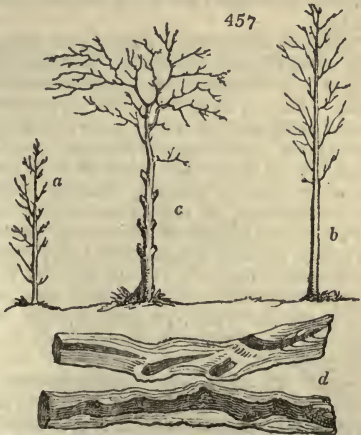

of leaves and small wood is necessary to every tree; but all above that quantity are of no use to the plant, and of little value to its owner." (*Forest Pruner*, 152 and 153.)

3690. *The great importance of the leaves of trees* must never be lost sight of: in attending to these instructions their use is not, as Pontey asserts, to attract the sap, but to elaborate it when propelled to them, and thus form the extract or food taken in by the plant, into a fluid analogous to blood, and which is returned so formed by the leaves into the inner bark and soft wood. It must be a very nice point, therefore, to determine the quantity of branches or leaves that should be left on each tree; and if no more are left than what are necessary, then in the case of accidents to them from insects, the progress of the tree will be doubly retarded. Experience alone can determine these things. Both Pontey and Sang agree that "strength is gained as effectually by a few branches to a head as by many."

3691. *The general seasons of pruning* are winter and spring, and for the gean mid-summer, as it is found to gum very much at any other season. Pontey says, "as to the proper seasons of pruning there is only one difficulty; and that is, discovering the wrong one, or the particular time that trees will bleed. Only two trees have been found which bleed uniformly at certain seasons, namely, the sycamore, and firs, which bleed as soon as the sap begins to move."

3692. *In spring pruning* desist when bleeding takes place. As a general rule, Pontey thinks "summer preferable to winter-pruning; because, in proportion as wounds are made early they heal so much more in the same season." (*Forest Pruner*, 236.) Sang suspends pruning from the end of February to the middle of July, but carries it on during every other month of the year; pruning the gean, or any other tree very apt to gum, only in July and August. (*Plant. Kal.* 268.)

3693. With respect to *the implements to be used*, Sang observes, "in every case where the knife is capable of lopping off the branch in question, namely, in the pruning of infant plants, it is the only instrument necessary. All other branches should be taken off by the saw. A hatchet, or a chisel, should never be used. Every wound on the stem, or hole, should be quite into the quick, that is, to the level and depth of the bark; nor should the least protuberance be left. The branch to be lopped off by the saw should, in all cases, be notched or slightly cut on the under side, in order to prevent the bark from being torn in the fall; and when the branch has been removed, the edges of the wound, if anywise ragged, should be pared smooth with the knife. If the tree be vigorous, nature will soon cover the wound with the bark, without the addition of any plaster to exclude the air. In the shortening of a strong branch, the position of which is pretty upright, it should be observed to draw the saw obliquely across it, in such a manner that the face of the wound shall be incapable of retaining moisture; and afterwards to smooth the edges of the bark with a knife." (*Plant. Kal.* 181.)

3694. *In every case where the branches are too large for the knife*, Pontey prefers the saw as the best and most expeditious instrument; and one, the use of which is more easily acquired by a laborer than that of either the bill or axe. In "large work" he uses the common carpenter's saw; for smaller branches, one with somewhat finer teeth, with the plate of steel, about twenty inches long.—Having stated what is general in pruning, the next thing is to submit some particular applications of the art to resinous and non-resinous timber-trees, copse-wood, osier-holts, hedges and hedge-rows, and trees in parks.

3695. *Resinous trees*, Pontey and Sang agree, should not be pruned at so early an age as the non-resinous kinds. Sang commences about the sixth or eighth year, according to their strength or vigor, and removes no more than one or two tiers of branches at once. Pontey, when the plants are about eight feet high, gives the first pruning by "displacing two, or at most three tiers of the lower branches; after which, intervals of three years might elapse between the prunings, never displacing more than two tiers at once, except more shall prove dead." (*Forest Pruner*, 204.) Sang judiciously observes, "excessive pruning, either of pines, larches, or deciduous trees of any sort, is highly injurious, not only to the health of the plant, but to the perfection of the wood. If a sufficient number of branches are not left on the young plant to produce abundance of leaves, perfectly to concoct its juice, the timber will be loose in its texture, and liable to premature decay." (*Plant. Kal.* 182.) The opinions of Nicol and Monteith are at variance with those of Pontey and Sang, as to pruning resinous trees. Nicol advises leaving snags (*Pract. Plant.* 213.), and Monteith (*Forest. Guide*, 45.) says, "never cut off a branch till it has begun to rot, as the bleeding of a live branch will go far to kill the tree."

3696. *Non-resinous trees*, Sang observes, "should be pruned betimes, or rather from their infancy, and thenceforward at intervals of one, or at most two, years. If the pruning of young forest-trees is performed at intervals of eight or ten years, the growth is unnecessarily thrown away, and wounds are inflicted which will ever after remain blemishes in the timber; whereas, if the superfluous or competing branches had been

removed annually, and before they obtained a large size, the places from which they issued would be imperceptible, or at least not hurtful to the timber, when it came to the hand of the artist."

3697. *The pruning of all deciduous trees should be begun at the top, or at least those branches which are to be removed from thence should never be lost sight of.* "Having fixed upon what may be deemed the best shoot for a leader, or that by which the stem is most evidently to be elongated and enlarged, every other branch on the plant should be rendered subservient to it, either by removing them instantly, or by shortening them. Where a plant has branched into two or more rival stems, and there are no other very strong branches upon it, nothing more is required than simply to lop off the weakest clean by the bole, leaving only the strongest and most promising shoot. If three or four shoots or branches be contending for the ascendancy, they should, in like manner, be lopped off, leaving only the most promising. If any of the branches which have been left further down on the bole of the plant at former prunings have become very strong, or have extended their extremities far, they should either be taken clean off, by the bole, or be shortened at a proper distance from it; observing always to shorten at a lateral twig of considerable length. It is of importance that the tree be equally poised; and, therefore, if it have stronger branches on the one side than the other, they should either be removed or be shortened. Thus, a properly trained tree, under twenty feet in height, should appear light and spiral, from within a yard or two of the ground to the upper extremity; its stem being furnished with a moderate number of twigs and small branches, in order to detain the sap, and circulate it more equally through the plant.

3698. *The subsequent prunings of trees of this size, standing in a close plantation, will require much less attention; all that is wanted will consist in keeping their leading shoots single.* From the want of air, their lateral branches will not be allowed to extend, but will remain as twigs upon the stem. These, however, frequently become dead branches; and if such were allowed to remain at all on the trees, they would infallibly produce blemishes calculated greatly to diminish the value of the timber: hence the impropriety of allowing any branch to die on the bole of a tree; indeed, all branches should be removed when they are alive; such a method, to our knowledge, being the only sure one to make good timber. From these circumstances, an annual pruning, or at least an annual examination of all forests, is necessary. (*Plant. Kal.*)

3699. *Heading down such non-resinous trees as stole, we have already stated to be an important operation.* After the trees have been three or four years planted, Sang directs, that "such as have not begun to grow freely should be headed down to within three or four inches of the ground. The cut must be made with the pruning-knife in a sloping direction, with one effort. Great care should be taken not to bend over the tree in the act of cutting. By so bending, the root may be split, a thing which too often happens. The operation should be performed in March, and not at an earlier period of the season, because the wounded part might receive much injury from the severe weather in January and February, and the expected shoot be thereby prevented from rising so strong and vigorous." (*Plant. Kalend.* 297.) Buffon, in a *Memorial on the Culture of Woods*, presented to the French government in 1742, says he has repeated this experiment so often, that he considers it as the most useful practice he knows in the culture of woods.

3700. *For the purpose of producing bends for ship-timber, various modes of pruning have been proposed, as such bends always fetch the highest price.* According to Pon-  
 tavey, "little is hazarded by saying, that if plenty of long, clean, straight, free-grown trees could be got, steaming and a screw apparatus would form bends."

3701. *Monteith, a timber valuator of great experience, and in extensive practice, says, the value of the oak, the broad-leaved elm, and Spanish chestnut, depends a good deal on their being crooked, as they are all used in ship building.* He says he has seen trees successfully trained into crooked shapes of great value, in the following manner: "If you have an oak, elm, or chestnut, that has two stems, as it were, striving for the superiority, lop or prune off the straightest stem; and if a tree that is not likely to be of such value be standing on that side to which the stem left seems to incline to a horizontal position, take away the tree, and thus give the other every chance of growing horizontally. At this time it will be necessary to take away a few of the perpendicular shoots off the horizontal branch; and, indeed, if these branches, which is sometimes the case in such trees, seem to contend, take away most of them; but if they do not, it is better at this time not to prune over much, except the crooked shoots on the horizontal branch, till they arrive at the height of fifteen, or even twenty feet. By this time it will be easily seen what kind of tree it is likely to form; and, if it inclines to grow crooked, lighten a little the top of the tree, by taking off a few of the crooked branches on the straighter side, allowing all the branches to remain on the side to which the tree inclines to crook, to give it more weight, and to draw most of the juice or sap that way,

and it will naturally incline more to the crook; at the same time clearing away any other tree on the crooked side, that may be apt, with the wind, to whip the side of the tree to which it inclines to crook. Also taking away such trees of less value as may prevent it from spreading out to the one side more than to the other." He adds, "I have myself tried the experiment with several oak trees at about twelve feet high, that were a little inclined to crook, and that had also a main branch inclined to a horizontal position. In the course of less than twenty years, I had the pleasure of seeing some of these very trees grow so very crooked that the branch would work in with the main stem or body of the tree, to a complete knee, or square, which is the most valuable of all trees; and, as ten trees of crooked oak are required for one straight one, it is of the most essential consequence to have crooked oak trees; and besides, an oak tree, properly crooked, that will answer for a large knee, (say the main branch, to be fit to work in with the body or trunk of the tree without much waste of wood), is nearly double in value to the same number of straight trees; and, indeed, knees of oak are extremely scarce, and difficult to be got."

3702. *Pontey* "knows of no way by which bends of tolerable scantlings (knees excepted) can be produced with certainty and little trouble, but from a side branch kept in a bent position by the branches of another tree or trees overhanging its stem." (*Forest Pruner*, 174.)

3703. *Coppice woods*, in so far as grown for poles or bark, require pruning on the same principle as timber trees, in order to modify the ligneous matter into stem, and produce clean bark. In as far as they are grown for fence wood, fuel, or besom spray, no pruning is required.

3704. *Osier hols* require the laterals to be pinched off the shoots intended for hoops; those of the basket-maker seldom produce any. The stools, also, require to be kept free from dead wood, and stunted knotty protuberances.

3705. *Hedges* require side pruning, or switching, from their first planting, so as gradually to mould them into "the wedge shape, tapering from bottom to top on both sides equally, till they meet in a point at the top. Two feet at bottom is a sufficient breadth for a five feet hedge; a greater or less height should have the bottom wider or narrower, accordingly. In dressing young hedges, either of the deciduous or evergreen kinds, the sides only should be cut till the hedge arrive at the proposed height, unless it be necessary, for the sake of shelter, to cut their tops over, in order to make the hedges thicker of branches. Such cutting of the upright shoots, however, is not of any great use in this respect; because every hawthorn hedge sends out a number of side shoots, which, if encouraged, by keeping the top wedge-shaped as above, will make it abundantly thick." (*Sang*, 447.) In pruning hedges, some use shears; but the hedge-bill is the most proper instrument, producing a smooth unfractured section, not so apt to throw out a number of small useless shoots as generally follow the bruised cut of the shears.

3706. *Hedge-row trees* require to be pruned to a tall, clean, erect stems, as at once producing more timber, and doing least injury to the ground under their drip and shade.

3707. Trees in *strips for shelter, or screens for concealment*, ought to be furnished with branches from the bottom upwards; unless undergrowth supply this deficiency. Where this is not the case, care should be had that the trees be pruned into conical shapes, so as that the lower branches may be as little as possible excluded from the influence of the weather by the upper ones.

3708. Trees for *shade*, where shelter from winds is not wanting, should be pruned to ample spreading heads with naked stems; the stems should be of such a height that the sun's rays, at midday, in midsummer, may not fall within some yards of the base of the trunk; thus leaving under the trees, as well as on its shady side, a space for the repose of men or cattle.

#### SUBJECT. 4. *Of Thinning Young Plantations.*

3709. *The properly thinning out of plantations*, *Sang* observes, "is a matter of the first importance in their culture. However much attention be paid to the article of pruning, if the plantation be left too thick, it will be inevitably ruined. A circulation of air, neither too great nor small, is essential to the welfare of the whole. This should not be wanting at any period of the growth of the plantation; but in cases where it has been prevented by neglect, it should not be admitted all at once, or suddenly. Opening a plantation too much at once, is a sure way to destroy its health and vigor. In thinning, the consideration which should, in all cases, predominate, is to cut for the good of the timber left, disregarding the value of the thinnings. For, if we have it in our choice to leave a good, and take away a bad plant or kind, and if it be necessary that one of the two should fall, the only question should be, by leaving which of them shall we do most justice to the laudable intention of raising excellent and full sized timber for the benefit

of ourselves and of posterity? The worst tree should never be left, but with the view of filling up an accidental vacancy.

3710. *In thinning mixed plantations*, the removing of the nurses is the first object which generally claims attention. This however should be cautiously performed; otherwise the intention of nursing might, after all, be thwarted. If the situation be much exposed, it will be prudent to retain more nurses, although the plantation itself be rather crowded, than where the situation is sheltered. In no cases, however, should the nurses be suffered to overtop or whip the plants intended for a timber crop; and for this reason, in bleak situations, and when perhaps particular nurse plants can hardly be spared, it may be sometimes necessary to prune off the branches from one side entirely. At subsequent thinnings, such pruned or disfigured plants are first to be removed; and then those which, from their situation, may best be dispensed with.

3711. *At what period of the age of the plantation the nurses are to be removed*, cannot easily be determined; and, indeed, if the nurses chiefly consist of larches, it may with propriety be said, that they should never be totally removed, while any of the other kinds remain. For, besides that this plant is admirably calculated to compose part of a beautiful mixture, it is excelled by few kinds, perhaps, by none as a timber tree.

3712. *But when the nurses consist of inferior kinds*, such as the mountain ash or Scots pine, they should generally be all moved by the time the plantation arrives at the height of fifteen or twenty feet, in order that the timber trees may not, by their means, be drawn up too weak and slender. Before this time it may probably be necessary to thin out a part of the other kinds. The least valuable, and the least thriving plants, should first be condemned, provided their removal occasion no blank or chasm; but where this would happen, they should be allowed to stand till the next, or other subsequent revision.

3713. *At what distance of time this revision should take place*, cannot easily be determined; as the matter must very much depend on the circumstances of soil, shelter, and the state of health the plants may be in. In general the third season after will be soon enough; and if the plantation be from thirty to forty years old, and in a thriving state, it will require to be revised again, in most cases within seven years. But one invariable rule ought to prevail in all cases, and in all situations, to allow no plant to overtop or whip another. Respect should be had to the distance of the tops, not to the distance of the roots of the trees; for some kinds require more head room than others; and all trees do not rise perpendicular to their roots, even on the most level or sheltered ground.

3714. *With respect to the final distance to which trees, standing in a mixed plantation, should be thinned*, it is hardly possible to prescribe fixed rules; circumstances of health, vigor, the spreading nature of the tree, and the like, must determine. Whether the trees are to be suffered to stand till full grown; which of the kinds the soil seems best fitted for; whether the ground be flat or elevated; and whether the situation be exposed or sheltered, are all circumstances which must influence the determination of the ultimate distance at which the trees are to stand. It may, however, be said in general, that if trees be allowed a certain distance of from twenty five to thirty feet, according to their kinds and manner of growth, they will have room to become larger timber.

3715. *Plantations of Scots pine*, if the plants have been put in at three, or three and a half feet apart, will require little care until the trees be ten or twelve feet high. It is necessary to keep such plantations thick in the early part of their growth, in order that the trees may tower the faster, and push fewer and weaker side branches. Indeed, a pine or soft-wood plantation should be kept thicker at any period of its growth, than any of those consisting of hard-wood and nurses already mentioned; and it may sometimes be proper to prune up certain plants as nurses, as hinted at above for nurses in a mixed plantation. Those pruned-up trees are of course to be reckoned temporary plants, and are afterwards to be the first thinned out; next to these, all plants which have lost their leaders by accident, should be condemned; because such will never regain them so far, as after to become stately timber; provided that the removal of these mutilated trees cause no material blank in the plantation. Care should be taken to prevent whipping; nor should the plantation be thinned too much at one time, lest havoc be made by prevailing winds; an evil which many, through inadvertency, have thus incurred. This precaution seems the more necessary, inasmuch as Scots pines, intended for useful large timber, are presumed never to be planted except in exposed situations and thin soils. At forty years of age, a good medium distance for the trees may be about fifteen feet every way. It may be worthy of remark, that after a certain period, perhaps by the time that the plantation arrives at the age of fifty or sixty years, it will be proper to thin more freely, in order to harden the timber; and that then this may be done with less risk of danger, from the strength the trees will have acquired, than at an earlier period; but still it should be done gradually.

3716. *Plantations of spruce and silver firs*, intended for large useful timber, should be kept much in the manner above stated, both in their infancy and middle age. As

already remarked, planting and keeping them as thick as is consistent with their health, is the best means of producing tall, straight, clean stems, and valuable timber. When planted for screens or for ornament, they require a different treatment; which will be noticed in the proper place. "To larch plantations, the above observations will also apply, and indeed they are applicable to plantations of all kinds of resinous trees. It may be proper here to remark, that the exposed margin of all young plantations should be kept thicker than the interior. The extent to which this rule should be carried, must be regulated according to the degree of exposure of the situation, the age of the plants, the tenderness of the kinds, and other circumstances." Autumn, or very early in the spring, are the proper seasons for *thinning* where the trees are to be taken up by the root and replanted elsewhere; winter for thinning for timber and fuel; but such trees as are valuable for their barks should be left untouched till the sap rises in April or May.

3717. *Copse-woods* require thinning when young, like other plantations, and when once established the stools require to be gone over the second year after cutting, and all superfluous suckers and shoots removed. This operation should be repeated annually, or every two or three years, in connection with pruning, till within three or four years of the general fall of the crop.

#### SECT. VI. *Of the Improvement of Neglected Plantations.*

3718. *Neglected and mismanaged plantations* will include the greater number in Britain. The artificial strips and masses have generally never been thinned or pruned; and the natural wood or copse-woods improperly thinned or cut over. It is often a difficult matter to know what to make of such cases, and always a work of considerable time. "Trees," Sang observes, "however hardy their natures may be, which have been reared in a thick plantation, and consequently have been very much sheltered, have their natures so far changed, that if they be suddenly exposed to a circulation of air, which, under different circumstances, would have been salubrious and useful to them, will become sickly and die. Hence the necessity of admitting the air to circulate freely among trees in a thick plantation, only gradually, and with great caution."

3719. *A plantation which has become close and crowded*, having been neglected from the time of planting till perhaps its twentieth year, should only have some of the smallest and most unsightly plants removed; one, perhaps, in every six or eight, in the first season; in the following season, a like number may be removed; and, in two or three years afterwards, it should be gone over again, and so on, till it be sufficiently thinned. It will be proper to commence the thinning, as above, at the interior of the plantations, leaving the skirts thicker till the last; indeed, the thinning of the skirts of such a plantation should be protracted to a great length of time. With thinning, pruning to a certain extent should also be carried on. "If the plantation," Sang observes, "consists of pines and firs, all the rotten stumps, decayed branches, and the like, must be cut off close by the bole. It will be needful, however, to be cautious not to inflict too many wounds upon the tree in one season; the removing of these, therefore, should be the work of two or three years, rather than endanger the health of the plantation. After the removal of these from the boles of the firs and larches, proceed every two or three years, but with a sparing hand, to displace one or perhaps two tiers of the lowermost live branches, as circumstances may direct, being careful to cut close by the trunk, as above noticed. In a plantation of hard-wood, under the above circumstances, the trees left for the ultimate crop, are not to be pruned so much at first as might otherwise be required; only one or two of their competing branches are to be taken away, and even these with caution. If it be judged too much for the first operation to remove them entirely, they may be shortened, to prevent the progress of the competition; and the remaining parts may be removed in the following season; at which time, as before observed, they must be cut close by the bole." (*Plant. Kal.* 467.)

3720. *The operation of thinning and pruning, thickening or filling up, or renewing portions that cannot be profitably recovered*, should thus go on, year after year, as appearances may direct, on the general principles of tree culture. And for this purpose, the attentive observation and reflection of a judicious manager will be worth more than directions which must be given with so much latitude. Pontey has noticed various errors in

3721. Kennedy's *Treatise on Planting*, and even in Sang's *Kalendar*, on the simple subject of distances, which have originated in their giving directions for anticipated cases which had never come within their experience. "Most people," he says, "take it for granted, that if trees stand three feet apart, they have only to take out the half to make the distances six feet, though to do that, they must take down three times as many as they leave. By the same rule, most people would suppose that twelve feet

distance was only the double of six; but the square of the latter is only thirty-six, while that of the former is one hundred and forty-four, or four times the latter; so that to bring six feet distances to twelve, three trees must be removed for every one left." (*Profitable Planter*, 256, and *Forest Pruner*, 21.)

3722. *Copse-woods are sometimes improved by turning them into woods, which requires nothing more than a judicious selection and reservation of those shoots from the stools which are strongest, and which spring more immediately from the collar. But a greater improvement of copse-woods consists in cutting over the overgrown and protuberant stools by the surface of the soil (fig. 458 a, b, c, d), which has been found by Monteith completely to regenerate them. The operation is performed with a saw, in a slanting direction, and the young shoots being properly thinned and pruned, soon establish themselves securely on the circumference of large and perhaps rotten-hearted roots. (Forester's Guide, 60.)*



3723. *Neglected hedge-row timber may be improved by pruning according to its age.*

Blakey recommends what he calls fore-shortening, or cutting-in, as the best method both for young and old hedge-row timber. "This operation is performed by shortening the over-luxuriant side-branches (fig. 459 a), but not to cut them to a stump, as in snag-pruning; on the contrary, the extremity only of the branch should be cut off, and the amputation effected immediately above where an auxiliary side-shoot springs from the branch on which the operation is to be performed (b); this may be at the distance of two, four, or any other number of feet from the stem of the tree; and suppose the auxiliary branch which is left (when the top of the branch is cut off) is also over-luxuriant, or looks unsightly, it should also be shortened at its sub-auxiliary branch, in the same manner as before described. The branches of trees, pruned in this manner, are always kept within due bounds; they do not extend over the adjoining land to the injury of the occupier, at least not until the stem of the tree rises to a height (out of the reach of pruning), when the top-branches can do comparatively little injury to the land. By adopting this system of pruning, the bad effects of close pruning on old trees, and snag-pruning on young ones, will be avoided, the country will be ornamented, and the community at large, as well as individuals, benefited."

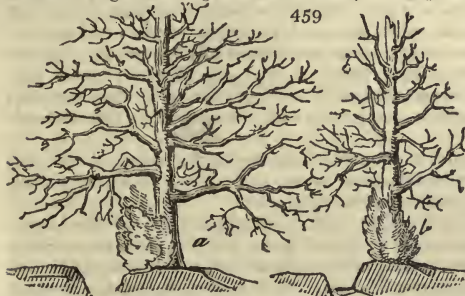

#### SECT. VII. *Of the Treatment of Injured and Diseased Trees.*

3724. *With respect to wounds, bruises, casualties, and defects of trees, such small wounds as are required to be made by judicious pruning, easily heal up of themselves; large wounds, by amputation of branches above six inches diameter, should, if possible, never be made. Even wounds of six inches diameter or under will heal quicker by the application of any material that excludes the air and preserves the wood from corruption; and we agree with Sang in recommending coal-tar, or the liquor produced from coals in manufacturing gas. It is, however, less favorable to the progress of the bark over the wound than a coating of clay or cow-dung covered with moss to keep it moist. Pontey recommends putty and two coats of paint over it. In case the wood, at a bruised or amputated place, has by neglect become already corrupted, the rotten or dead wood is to be pared out quite into the quick, and the wound is then to be dressed with tar or clay, covered with a piece of mat, sacking, or moss. A wound, hollowed out as above, may at first appear an unsightly blemish; but, in subsequent years, nature will lay the coats of wood under the new-formed bark thicker at that place; and probably may, in time, fill it up to be even with the general surface of the tree.*

3725. *All fractures, by whatever means produced, are to be managed as the circumstances of the case require. If a large branch be broken over at the middle of its length, it should be sawn clear off close by the lateral which is nearest to the bole of the tree: but, if there is no lateral, or branch, capable to carry forward the growth, cut the main or fractured branch in quite to the bole. In both cases, treat the wound as above recommended.*

3726. *Interior rotting*, arising from the dampness of the soil, cannot by the art of man be cured; though it might have been prevented by timous draining. The hearts of trees frequently rot, where there is no excess of moisture, and especially such as have been produced from old roots left in the ground by a previous felling. Such roots when in good ground, send up very great shoots, with few leaves in proportion to their sizes; by the absence of a profusion of these, properly to concoct the juices so abundantly supplied by the roots, the fibre of the wood is loose and imperfect; the next season will produce more leaves in proportion to the supply of juices, yet not a sufficient number for making timber; several years may pass before this event will arrive: thus crude and ill-digested timber disposed to premature decay is the foundation over which subsequent coatings of wood are laid: yet, however perfect these may be, they do not prevent the progress of decomposition going on in the interior. Nature teaches how necessary numerous leaves are to the proportion of the solid wood; the cotyledons and subsequent leaves of a one-year old tree, are a thousand times greater, compared to its solid contents, than are leaves to the solid contents of the first year's shoots from roots like the above.

3727. *Shakes* often arise from the weight and multiplicity of top branches, and might have been prevented by timous pruning. Shakes or rents in the boles of trees, however, often happen where there is no excess of tops. Sometimes the rain running down from the branches, wets one part of the bole, while the rest is comparatively dry. If this circumstance is succeeded by an intense frost, before the wetted side become dry, the bole may be rent for a length, and perhaps to the depth of the core. Shakes or rents, like the above, are difficult to cure. The best method of helping them, is to trace out their upper extremity, caulk it up with oakum, and pitch it over, to prevent the rain descending that way in future. (*Sang.*)

3728. *In cases of hollowness*, Pontey recommends probing to the bottom, letting out the water, if any, with an auger, drying the cavity with a cloth, filling it with dry sand, plugging it with wood and oakum, and then painting it over.

3729. *Decorticated stems or branches by lightning*, or otherwise, if the soft wood is not much injured, will heal over and become covered with bark; and this the more certainly and rapidly if the air be excluded by a coating of adhesive matter, as cow dung and quick lime, or tying on moss or bandages of mat or cloth. Pontey gives an instance in which such treatment was successful in the case of an apple tree. (*Pruner*, 230.) We have witnessed it on an extensive scale on the trunk of a pear tree; and we are informed, on the best authority, of other cases now under progress, in the government garden of the Luxemburg, at Paris.

3730. *Withered or decayed tops*, may arise from age and incipient decay; but also, as Pontey states, from improper pruning, or the want of it. We often see it from improper pruning elms, which, after having been close pruned to their summits for many years, are left entirely to nature; in that case they branch out luxuriantly below, and the top withers. By neglecting to thin out the branches on the stems of non-resinous trees the same effect may be produced.

3731. *Stinted bushy tops* on very tall naked stems, show a deficiency of nourishment, from these circumstances; and on short stems from defects of the soil. Obliquely placed misshapen heads, in detached trees, commonly proceed from the same causes and want of shelter. Stinted growth, both in tops and stems, is also produced by ivy, and by lichens, mosses, miseltoe, and other parasites. Ivy compresses the bark, precludes its expansion, as well as excludes air and moisture, by which the outer bark becomes rigid and corky. — Happily, both men and trees will live a long time under the influence both of deformity and disease.

3732. *Excessive exudations of gum and resins* are peculiar to resinous and some other trees when over pruned, or pruned at improper times. Mildew, honeydew, and blight; three popular names applied to the effects of certain insects of the *aphis* kind, attack the oak, beech, poplar, and many trees; all that can be said is, if proper regimen has been regularly attended to, trees will overcome these and all other enemies.

3733. *Insects and vermin*. Almost every tree has its particular insect of the hemipterous and dipterous families, and many of the coleoptera are common to all. The foliage of the small leaved elm of hedges is often almost entirely destroyed in the early part of the season by tenthrudinidæ; and those of the larch and Scotch pine have suffered materially in some seasons from aphides. The *aphis laricea*, L. (*Eriosomata*, of Leach,) increased to an alarming extent from 1800 to 1802, on the larch, on account of three dry seasons following each other; but, though it retarded their growth, it ultimately destroyed very few trees. *Sang* says, he has known it since 1785; that it dirties more than injures the tree, and is now (1819) thought little of. Indeed, almost every species of tree has been known to have suffered in some one or more seasons, and in particular districts from insects; for which, on so large a scale, there seems to be no applicable remedy, but patiently waiting till their excess, or the increase of other vermin, their natural enemies,



or a change of seasons, cause them to disappear. Trees properly cultivated and managed, generally overcome such enemies. The hare is well known to be injurious to young trees, and especially to laburnums, by gnawing off their bark. Coating their stems with dung and urine, fresh from the cow-house, is said to be an effectual remedy. It may be put on with a brush to the height of two feet; a barrow load will suffice for a hundred trees, with stems of three or four inches in diameter; and its virtue, after laid on, endures at least two years. (*Bull. in Cald. Hort. Mem. iv. 190.*)

SECT. VIII. *Of the Products of Trees and their Preparation for Use or Sale.*

3734. *The ordinary products of trees* made use of in the arts are leaves, prunings, or spray, thinnings, seeds, flexible shoots, bark, branches, roots, and trunks. Trees also afford sap for wine and sugar, and extract for dyeing; but these products are of too accidental or refined a nature for our present purpose.

3735. *The leaves and spray of trees* when gathered before they begin to decay, may be given to cattle either in their fresh state or dried and stacked up for winter use, as is practised in various countries. In this country, however, leaves and spray, as the clippings of hedges and small prunings, are only used as manure; or as a substitute for tanners' bark in gardens.

3736. *The thinnings*, when not beyond a suitable age, and taken up properly, and at a proper season, may be planted in other situations, or as single trees and groups; or they may be used as hoops, hop-poles, poles for garden training, for fencing, for props in coaleries; and for a great variety of purposes; those, whose barks are useful for tanning, should not be cut down, or rooted up till May, but the others at any time during winter. It is common to sort them into lots, according to their kind or size; and to faggot up the spray for fuel, besom stuff, or for distilling for bleacher's liquid.

3737. *The seeds of trees* in general cannot be considered of much use beyond that of continuing the species. The seeds of the oak, beech, and sweet chestnut, however, are valuable for feeding swine, and where they abound may either be swept together after they drop, and carried away and preserved dry in lofts or cellars for that purpose; or if other circumstances are favorable, swine may be driven under the trees to collect them. These and other seeds, as the haw and holly, are also eaten by deer. The seeds of the trees mentioned, and of all the resinous tribe, are in general demand by the nurserymen for the purposes of propagation. The seeds of almost all other trees and shrubs are also in limited or occasional demand; or may be collected for private sowing. They generally ripen late in the season, and are to be collected in the end of autumn or beginning of winter, with the exception of a few, such as the elm, poplar, willow, and one or two others, which ripen their seeds in May and June.

3738. *In osier grounds*, willows produce flexible shoots, and whether intended for the basket-maker or cooper, should not be cut till the second season after planting, in order to strengthen the stools; but by the third autumn the crop will be fit for the basket-maker, and in the fourth, plantations intended for the cooper (hoops requiring the growth of two years) will be ready. The seasons for cutting are November and March; after the former period the wounds are apt to be injured by frost, and after the latter the sap is too far advanced; some is lost by bleeding, and the buds are developed too suddenly to admit of proper strength in the shoots. The cut should be made within three buds of the point whence the shoot issued, in a sloping direction, and the section on the underside. In cutting hoop-willows, the swell at the bottom of the shoot only should be left, that being furnished with abundance of buds for future growth. After being cut, the hoops are trimmed from any side-shoots, and tied up in bundles of a hundred, of six scores each, which, in 1820, sold for from four shillings to five shillings a bundle. The willows are sorted into three sizes, and tied in bundles two feet in circumference, within a foot of the lower ends. When to be peeled, they are immediately after cutting set on their thick ends in standing water, a few inches deep, and there they remain till the sap ascends freely, which is commonly by the end of the succeeding May. "The apparatus for peeling is simply two round rods of iron, nearly half an inch thick, sixteen inches long, and tapering a little upwards, welded together at the one end which is sharpened, so as that it may be easily thrust down into the ground. When thus placed in a piece of firm ground, the peeler sits down opposite to it, and takes the willow in the right hand by the small end, and puts a foot or more of the great end into the instrument, the prongs of which he presses together with the left hand, and with the right draws the willow towards him; by which operation the bark will at once be separated from the wood: the small end is then treated in the same manner, and the peeling is completed. Good willows peeled in the above manner, have been sold for some seasons past, at from six shillings and sixpence to seven shillings the bundle of four feet in circumference. After being peeled, they will keep in good condition for a long time, till a proper market be found."

3739. *Copse-woods* are generally cut over when the shoots of the stools have attained from three to five inches' diameter at their bases; some grown chiefly for hop-poles, and ware or stuff for crates, hampers, or watted hurdles, are cut over earlier, and others, where small timber for fencing and other country purposes is wanted, are left later. In some parts of Herefordshire, where the oak grows with great rapidity, copse-woods are cut over every twelve years; in the highlands of Scotland, where it grows much slower, the time varies from twenty to twenty-five or thirty years. "The bark is there considered as having arrived at its utmost perfection and at its highest value, at the age of between twenty and thirty years: under that age, its virtues are weak; above it, the bark becomes coarse and loses its sap. Another important reason for cutting down oak coppice-wood about the above period, is suggested in the *Stirlingshire Report*, p. 218.; namely, 'that it is a fact established by experience, that it will not renew itself, if it remains uncut, beyond the space of about forty years.'" (*Gen. Rep. of Scotland*, 218.) Where there is a considerable tract of copse-wood, it is common to divide it into portions, in number according to the period of cutting. These are to be cut in rotation, so that when the last portion is cut over, the first is again ready for cutting.

3740. *The season for cutting* the kinds of trees whose barks are not made use of, is winter and early in spring; but the oak and other trees which are peeled, are left till the middle of April or May. Birch and larch woods will peel nearly a month earlier than the oak. Should there be no frost, birch and larch may be peeled about the beginning of April; but the birch is commonly allowed to stand till July, and the peeling of it is commenced after that of the oak has been completed. The reason is, there is an outer skin upon birch-bark which requires to be taken off, as it is of no use to the tanner, and renders that part which is of use more difficult to be ground; the month of July is the only time at which the two barks can be separated with ease, as at this time the juice or sap has made its circulation through the tree and bark, and this circumstance renders the separation more easy. From the beginning of May to the middle of July is the usual time for barking the oak. The earlier in the spring this operation is performed on the oak, both for the growth, if a natural wood, and for the bark, the better. When the sap has begun to rise, the bark will easily be detached from the wood, and it ought then to be taken off without loss of time; and if the whole could be taken off before the leaf is completely developed, the bark would be better. After the sap has arisen to the leaf and new growth, the bark becomes more dry, and requires more beating to separate it from the wood. And when what is called the black sap is descending the tree, the bark taken off is black, and loses its original color; at this time also the bark begins to throw off a scurf, more especially young bark without much cork on it; this outer skin having less of the proper sap or juice, and being much drier when taken off, will weigh less, and consequently will not be so valuable. If possible, oaks should be barked by the middle of June, as every ton of bark taken off after the first of July will be deficient two cwt. per ton, compared with the same quantity taken off in May or early in June.

3741. *The termination of cutting* is generally fixed for the fifteenth day of July, and after this date there should not be a single stool of oak wood cut that is intended for the growth; and as soon as possible after the fifteenth, the whole of the wood and bark should be carried away, that the young growths may not be disturbed or injured, as at this time they will have made considerable progress; at any rate, there should neither be wood nor bark remaining within the new cut hag after the first of August; nor should either horse or cart be permitted to enter it after that period, for after the beginning of August, oaks make what is termed a lammas growth, and the future prosperity and health of the coppice, in a great measure, depend on the first year's growth, as far as regards form and vigor of the shoots. (*Forester's Guide*, 69.)

3742. *The best mode of cutting* is evidently that of using a saw, and cutting the shoots over in a slanting direction close by the surface. When the stool, after having been cut several times, has acquired considerable diameter, it is customary in the midland counties, Marshal states, to hollow it out in the centre, from a notion that by rotting away the central roots, the circumferential stems will grow more vigorously, and become as it were separate plants. This is in fact the case in very old copses. For several cuttings, however, it must evidently be the safer policy to keep the stool highest in the middle to throw off the rain, and preserve it sound.

3743. *Monteith* says, "It will be found, upon experiment, perfectly evident, that stools dressed down to the surface of the ground, (taking care always not to loosen the bark from the root, or allow it to be peeled off in the smallest degree below the earth, but rounded down level to it,) will send forth the most vigorous shoots, and stand the weather, and be the stoutest and best throughout the age of the coppice." (*Forester's Guide*, 61.) From the late season at which the trees to be barked are generally

cut, they often receive considerable injury, both from that circumstance, and the manner in which the operation is performed. Monteith appears to us to have furnished the best directions for executing the work in a safe manner. He first sends a person furnished with an instrument with a sharp cutting edge (*fig. 460 a*) through the copse, whose business is "to trample down the long grass or foggage all round the root, and then, to make a circular incision into the bark so deep as to reach the wood, at about an inch above the surface of the earth; thus the bark when taken off, will injure no part of that which is below the circular incision."

3744. *The root of the tree being thus prepared*, the cutters ought to proceed to their part of the work, not with an axe, however, as is most generally recommended, but with a saw, because, in cutting with the axe, unless the root of the tree be so small in diameter as to be severed in one or two strokes at most, the axe loosens the root to such a degree, that it not only loses the present year's growth, but often fails altogether to grow. Therefore if the diameter of the root be six inches, or upwards, it should always be cut with a cross-cut saw; entering the saw about half an inch above where the circular incision has been made into the bark, if a small tree; but if the tree be ten or twelve, or more inches in diameter, the saw ought to be entered two inches above it.

3745. *There are two advantages to be derived from cutting with the saw*; it has no tendency to loosen the root of the tree, but leaves it in such a condition as to be more easily and properly dressed; it also saves a portion of the wood that would otherwise be destroyed by the axe. On no pretence should oaks of six inches' diameter be cut with an axe, but always with a saw. Having cut through the tree with a saw, take a sharp adze, and round the edges of the stool or root, going close down to the surface of the earth, taking with the adze both bark and wood, sloping it up towards the centre of the stool, taking particular care always that the bark and wood both slope alike, as if they formed one solid body, being sure always that the bark be not detached from the root. An objection has been made to this mode of cutting with the saw, as taking up too much time; but I have found that two men with a cross-cut saw, kept in good order, will cut as much as two men will with an axe. (*Forester's Guide*, 58.)

3746. *The debarked timber is prepared for sale by being sorted into straight poles of the largest size, stakes and other pieces fit for palings, faggots, fuel, &c.* The unbarked wood is similarly sorted, and affords, where there is much hazel or ash, cord wood or bundles of clean shoots for making packing crates, hampers, &c., poles for hops, larger poles for fences, rails, paling-stakes, stakes and shoots for hurdles, besom-stuff, spray for distillation, and a variety of other objects according to the local demand, or the opportunity of supplying a distant market by land-carriage. The brush or spray of non-resinous trees is called in some places ton-wood, and is used for distilling the pyroliginous acid used in bleach-fields and calico print-works. "When wood of this description is sent to Glasgow, where there are extensive works for the purpose of distilling it, it sells readily at from *l. 2s.* to *l. 10s.* per ton; but when there are large cuttings, particularly of young woods, it is worth while to erect boilers near the wood to distil it, as these boilers can be erected at no great expense, and in this case the liquid is easily carried in casks to where it is consumed, at less expense than the rough timber could be; of course it will pay much better. Small wood of this description is also used for charcoal: but in distilling it, there is part of it made into charcoal, which will supply the demand of that article, so that it is by far the most profitable way, when there is any great quantity to dispose of, to erect boilers and distil it; unless where the local situation of the wood will admit of its being shipped at a small expense, and carried to where the works mentioned are carried on. All kinds of non-resinous woods will give the extract in question; but oak, ash, Spanish chestnut, and birch, are the best." (*Forester's Guide*, 155.) Where the oak grows slow, as in the highlands, the but-ends of the poles are used for spokes for chaise wheels. "Long spokes are from thirty to thirty-two by three inches and a half broad, and one inch and a half thick, and the short ones for the same purpose, from twenty-two to twenty-four inches long, and the same sizes otherwise. Cart-wheel spokes, from twenty-six to twenty-eight inches long, four inches broad by two inches thick. These are the sizes they require to stand when rough blocked from the axe. Small wood when sold for this purpose, brought, in 1820, *2s.* a cubic foot, measured down to three inches square." (*Monteith.*)

3747. *In some cases copse-woods are sown with grass-seeds, and pastured by sheep, horses, and cattle.* Some admit the animals the fifth year after the last cutting, others, not till the eighth: but Monteith thinks this should never be done till the fifteenth year. If the ground is properly covered with trees, it can seldom be advantageous to admit any species of stock unless during a month or two in winter.

3748. *In the operation of barking trees*, "the barkers are each furnished with light short-handed mallets, made of hard-wood, about eight or nine inches long, three inches square at the face, and the other end sharpened like a wedge, in order the more easily

to make an incision in the bark, which is done all along the side of the tree which happens to be uppermost, in a straight line: and as two barkers are generally employed at one tree, it is proper, that whilst the one is employed in making an incision with the mallet, as above, the other being furnished with the barking-bill (*fig. 460 a*), cuts the bark across the tree, in lengths of from two feet six inches to three feet. Having thus made the incision in the bark, both ways, the barkers being also each furnished with peeling irons of different sorts (*b, c, d, e*), if the tree or piece of timber to be barked is such as the two barkers

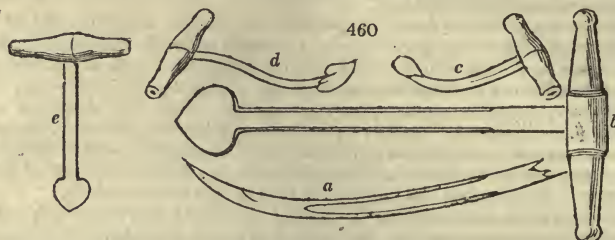

can easily lift one end of it, this is placed on two pieces of wood three feet long, and called horses; these are about the thickness of a paling-stake, and have a forked end on each about six inches long, the other end sharpened to go into the ground; two of these horses are placed in a triangular form against one another, one end of the piece to be peeled being raised on the horses, the two barkers standing opposite to each other, and entering the peeling-irons into the incision made by the mallet, and pressing the iron downwards between the bark and the timber. In this way it will be found very easy to take the bark off in one whole piece round the tree; and, if possible, let these pieces be as long as the incisions made in the bark. In some cases, where there is not much sap, the bark may require a little beating with the square end of the mallet, to cause it to separate easily from the wood; but the less beating with the mallet the better, as it has a tendency to blacken the bark in the inside, or fleshy part of it, so that when the tanner sees it, he supposes it to be damaged, and undervalues it. The branches of the tree being previously all lopped off with the axe, the persons, in number according to the extent of the work, with the bill smooth all the branches, cutting them in lengths of from two feet six inches to three feet, down as small as one inch in circumference. The barkers, principally women, are each provided with a smooth hard stone of about six or eight pounds weight, beside which they sit down, and having collected a quantity of saplings, branches, or twigs, they hold it on the stone with one hand, and with the mallet in the other, they beat the piece till the bark be split from the wood, from the one end to the other, and taking it off all the length of the piece, if possible, then lay it regularly aside, till a bundle of considerable size is formed."

3749. *Drying the bark.* The point most particularly to be observed in this art is, putting the bark up to dry; which is done by setting it upon what is called the lofts or ranges. These are erected by taking forked pieces of the loppings, called horses, the one three feet long, the other two feet six inches, and driving each about four inches into the ground, opposite one another, about two feet asunder in the breadth, and as much betwixt them, lengthways, as will admit long small pieces of wood to be put upon them, and as many of these must be put together as will hold the bark of every day's peeling. These ought to be erected in as dry and elevated a spot as can be found in the margin of the wood, or better on its outside. The bark being carried and laid on this loft, with the thick ends of it all laid to the high side of the range, and the small bark laid on to the thickness of about six inches; and the bark taken off the largest of the wood laid regularly on the top, which serves for a covering, and the lofts or ranges having a declivity of about six inches, the rain will run off them readily, and if properly put up in this manner, they will keep out a great deal of rain. After it has lain in this state for three days, if the weather is good and dry, it ought to be all turned over, and the small bark spread out, so as not to allow it to sit together, which, if much pressed, it is apt to do; and if it does so with the natural sap in it, it has a chance of moulding, which is extremely hurtful to the bark, and both lessens it in weight and in value. After the bark has stood on the ranges about eight or ten days, if the weather be good, it may either be put into a house or a shed, or if intended to be put up into a stack, it may now be done. A stack of bark ought never to exceed eight feet in width, and twelve or fifteen feet in height, raised in the middle like a baystack. If it is to stand any length of time in the stack, it ought to be thatched, and in that state may remain all winter. The greatest care ought to be taken to preserve the color of the inner parts of the bark, because the color of it is generally looked to as a principal criterion of its value. Before being put into the stack,

the natural sap ought to be dried out of it, in order to prevent its fermenting; because if a fermentation takes place in one part of the stack, it generally goes through and spoils the whole. The same mode of treatment will do for all kinds of bark as well as the oak; but the birch has an outer or shredly skin upon it, that is rejected by the tanner, and, as already observed, must be peeled off.

3750. *Chopping the bark.* "When the bark is ready for the tanner, it has to undergo the work of chopping, which is done by driving in two or more stakes into the ground, with a fork on the upper end of each, leaving them about two feet six inches from the ground, and laying a long small piece of wood across between the two, where a number of people stand, and the bark is carried and laid down behind them, which they take up in their hands and lay on the cross tree, and then, with a sharp whittle or bill in the other hand, they cut it into small pieces, about three inches in length; when this is done, it is trampled into bags, which hold about two hundred weight each, and in these bags it is weighed when sold by the ton, in tons, hundred weights, quarters, and pounds, and in the above manner delivered to the merchant or tanner." (*Forester's Guide*, 199.)

3751. *Pollard-trees*, which may be considered in most cases as injurious deformities, are lopped at stated periods like copse-woods, and the lop, whether to be barked or otherwise, is to be treated in all respects like that of copse.

3752. *The period at which trees are felled*, for the sake of their timber, is determined by various causes. By maturity of growth, or where the annual increase is so trifling as to render their standing no longer worth while in point of profit: when wanted for private use or sale; or when defects in the tree, or new arrangements in its situation, point out the necessity of its removal. "A timbered estate," Marshal observes, "should frequently be gone over by some person of judgment; who, let the price and demand for timber be what they may, ought to mark every tree which wears the appearance of decay. If the demand be brisk and the price high, he ought to go two steps farther, and mark not only such as are full-grown, but such also as are near perfection." In trees, as in the human species, there are three stages, youth, manhood, and old age. In the period of youth, the growth is rapid; in manhood, that growth is matured; and in old age, it begins to decay.

3753. *The most profitable season for felling timber* is at what may thus be termed the beginning of manhood. After that time, though the tree may appear sound and healthy; its annual increase is so little, that it would be more profitable to cut it down and replant. The number of years that a tree may stand, before it arrives at this period, must vary in different soils and situations; but the period itself may easily be ascertained — by the annual shoots — the state of the bark — and by taking the circumference of the tree at the same place for two or three successive seasons, and comparing the difference. In the view of profiting from timber produce, it is of great consequence to cut down plantations at maturity. Many trees will stand half, others a whole century, after they are full-grown, appear quite healthy, and at the same time, make little or no increase of timber. But there are particular cases, arising from the nature and state of the markets, where it may even be more profitable to cut timber before it is arrived at a full growth. (*Treat. on Countr. Res.* ii. 577.)

3754. *Preparations for felling.* It has been strongly recommended to disbark trees a year or more before they are taken down in consequence of the result of certain experiments commenced by Buffon in 1737. In May of that year, he disbarked three oak-trees, forty feet in height, where they stood. In the course of three years they died, and, on cutting them down, the outer wood was found hard and dry, and the internal wood moist and softer. After trying its strength, &c. he concludes, that "timber which has been disbarked and dried while standing, will weigh heavier, and prove stronger than timber cut in its bark." Bosc, and other French authors, (in *Cours Compl. d'Agr. &c.* art. *Aubier, Bois, Quercus*, &c.) strongly recommend this practice, which is followed in some places on the continent, and in this country with the oak and larch; but not, as far as we have learned, with any other tree. Monteith finds it by far the most efficient way of seasoning larch-timber. He barked some trees in spring, and did not cut them down till autumn, and others stood in the peeled state for two years. After various and extensive trials, he is "decidedly of opinion, that the larch treated in this way at thirty years of age will be found equally durable with a tree cut down at the age of fifty years, and treated in the ordinary way." (*Forester's Guide*, 152.)

3755. *As the dry rot* (*Merulius destruens*, Sow.) is found to arise in a great measure from want of seasoning, or at least to proceed with the greatest rapidity in timber not well seasoned, this practice seems to deserve adoption in that point of view. (*Encyc. Brit. Suppl.* art. *Dry Rot*.) In some parts of the north of Europe, the trees are divested of their bark for one or two feet in height from the ground a year or more previous to that on which they are to be felled. We saw this done in Poland and Lithuania; but though we made diligent enquiry there and in Sweden, we could not learn distinctly the extent to which it was practised in the latter country and Norway. It is occasionally

practised in Poland for the ostensible purpose of hardening the soft wood; but also accompanied by a deep incision made for the purpose of extracting tar; a practice obviously injurious to the timber, and therefore generally in these countries kept out of view. When trees stand close together, a very obvious preparation to felling is lightening the tops of such branches as would do injury in falling to the trees that are to be left, or to other adjoining objects.

3756. *The season of felling* is commonly winter, for timber not to be disbarked; but some for the resinous tribe recommend summer as being the season in which it is generally felled in the north of Europe and in the Alps. But the summer season is there adopted from necessity, as in winter the woods are so filled up with snow that felling is hardly practicable. As the timber of these countries is generally squared for the market; the soft wood is chiefly removed, so that the season of felling does not seem to them to be of much consequence. Besides, the timber is never so full of sap in summer as it is in spring and autumn, and therefore, next to mid-winter, midsummer may be the next best time for felling all kinds of timber-trees. Where the trees are disbarked at the base a year or more before felling, the soft wood will be partially hardened; but this practice is by no means general in the north.

3757. *Knowles*, in a recent work on preserving the British navy, and on dry rot, &c. after collecting the opinions of all the ancient and modern authors who have written on felling timber, concludes, that the common notion that trees felled in winter contain less of sap or of the vegetable juices than those cut down at any other season of the year, is not true; and that the method of barking standing trees in spring, and not felling them till the succeeding winter, has not in any way realised the expectations formed of the plan. After describing all the different modes that have been adopted for seasoning timber, he concludes, that the best mode of seasoning is to "keep it in air, neither very dry nor very moist; and to protect it from the sun and rain by a roof raised sufficiently high over it so as to prevent by this and other means, a rapid rush of air." (*Inquiry into the Means of preserving the British Navy from Dry Rot, &c. by Knowles, Sec. to the Com. of Surveyors, chap. iii.*)

3758. *The operation of felling* is performed either by digging an excavation round the stem, and cutting the roots at two- or three feet distance from it, or by cutting over the stem at the surface. By the former mode the root is obtained for use, and the ground more effectually cleared and prepared for the roots of other adjoining trees, or whatever crop is to follow. Where the tree is intended to stole, which can very seldom be advisable in the case of cutting full-grown timber, or where there is some nicety in taking it down so as not to injure other trees or adjoining objects, it is cut or sawn over, and the root, if to be removed, dug out afterwards. "In cutting large trees, in order to make the tree fall the way required, enter the cross-cut saw on that side of the tree it is intended to fall, and cut it about a third part through; then enter the saw at the other side, and when it is cut so far as to admit a wedge, place the wedge exactly opposite the way you want the tree to fall, and keep driving it slowly till the tree is nearly cut through." (*Monteith.*) The tree being felled, is next divested of its branches, which are sorted into fence-wood, fuel, ton-wood, &c., according to the kind of tree; and the trunk is generally preserved as entire as possible for the purchaser. Sometimes it is cut in two, and the root-cut, or but-end, being the most valuable, sold for one class of purposes at a higher price, and the top-cuts for others somewhat lower.

3759. *The roots of trees* are the last product we shall mention. These should, in almost every case, be effectually eradicated; to aid in which, in the case of very large roots, splitting by wedges, refest by gunpowder, tearing up by the hydrostatic press, or by a common lever and triangle (*fig. 461.*), may be resorted to. Some compact ash or oak roots are occasionally in demand by smiths, leather-cutters, and others; but in general roots should be reduced to pieces not exceeding three feet long, and six inches in diameter, and put up in stacks not less than three feet every way, but commonly containing two cubic yards. These, when dry, are sold for fuel, or reduced to charcoal on the spot. In eradicating and stacking up coppice-woods, it is common to allow a certain sum per stack, and something for every acre of ground cleared; if there are no trees to bark, allowances are also made for the poles, faggots, &c. so that no part of the operation is performed by day-work.

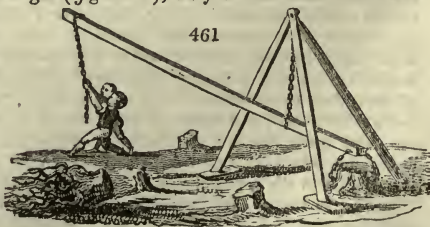

3760. *The usual method of charring wood* is as follows:—The wood being collected near the place intended for the operation, and cut into billets, generally about

three feet in length, the pits or stacks are usually formed in this manner: A spot, adapted to the purpose, of from about fifteen or twenty feet in diameter, of a conical form, is selected, and after being properly levelled, a large billet of wood split across at one end, and pointed at the other, is fixed in the centre of the area, with its pointed extremity in the earth, and two pieces of wood, inserted through the clefts of the other end, forming four right angles; against these cross-pieces, four other billets of wood are placed, one end on the ground, and the other leaning against the angles. A number of large and straight billets are afterwards laid on the ground, to form a floor, each being, as it were, the radius of the circular area; on this floor, a proper quantity of brush or small wood is strewed, to fill up the interstices, when the floor will be complete: and in order to keep the billets in the same position in which they were first arranged, pegs or stumps are driven into the ground, in the circumference of the circle, about a foot distant from one another; upon this floor a stage is built, with billets set upon one end, somewhat inclining towards the central billet, and on the tops of these another floor is laid, in a horizontal direction, but of shorter billets, as the whole is intended, when finished, to form a cone. The whole is then coated over with turf, and the surface generally plastered with a mixture of earth and charcoal-dust.

3761. *Previous to the operation of setting fire to the pile, the central billet in the upper stage is drawn out, and pieces of dry combustible wood substituted in its place, to which the fire is applied.* Great attention is necessary during the process, in the proper management of the fire, and in immediately covering up the apertures through which the flame obtrudes itself, until the operation be concluded, which is generally effected in the space of two or three days according to circumstances. When the charcoal is thought to be sufficiently burnt, which is easily known from the appearance of the smoke, and the flames no longer issuing with impetuosity through the vents; all the apertures are to be closed up very carefully, with a mixture of earth and charcoal-dust, which, by excluding all access of the external air, prevents the coal from being any further consumed, and the fire goes out of itself. In this condition it is suffered to remain, till the whole is sufficiently cooled; when the cover is removed, and the charcoal is taken away. If the whole process is skilfully managed, the coals will exactly retain the figure of the pieces of wood: some are said to have been so dexterous, as to char an arrow, without altering even the figure of the feather. (*Encyc. Brit.* vol. v. art. *Charcoal.*)

3762. *The method of charring wood, for the making of gunpowder, according to an improved system, adopted not many years ago, is however a much more costly operation, though the expense attending it is amply compensated by the superior excellence of the article when manufactured.* It is done in iron cylinders, and in so complete a manner, that every particle of the wood is charred. The oily or tarry matter is also preserved, and may, so far as the quantity goes, be made use of instead of foreign tar or pitch. This mode of charring wood for making gunpowder, is carried to the greatest perfection, near Petworth in Sussex, and there is a manufacture of a similar nature near Chester. (*Gen. Rep. for Scotland*, vol. ii. p. 342.)

SECT. IX. *Of estimating the Value of Plantations and their Products, and of exposing them to Sale.*

3763. *The valuation of timber forms a distinct profession, and can only be acquired by continued observation and experience: like other valuations of property, it depends on a great variety of considerations, some of a general, but the greater part of a local nature.* We have already offered some remarks on valuing young plantations, as a part of what may be called the inherent value of landed estates (3089.); and shall here confine ourselves to the valuation of saleable trees.

3764. *In valuing saleable trees of any kind, their number per acre, or their total number by enumeration, being ascertained, and the kinds and sizes classed, then each class is to be estimated according to its worth as timber, fence-wood, fuel, bark, &c.* "In a coppice wood which cannot readily be measured, the readiest method of counting the stools is, to cause two men to take a line, say about a hundred feet long, or more, and passing the line round as many of the stools as it will enclose, the one man standing, while the other moves round a new number of stools, and count always the stools betwixt the two lines, causing the one man to move, the one with the line, while the other stands still, and so on alternately. The valuator at the same time taking care to average every twenty stools as they go on, before losing sight of the counted stools. This way, too, is a very speedy and sure method of counting the number of trees in any plantation.

3765. *Or the stools of a coppice wood may be counted and averaged by two men going parallel to each other, and the person valuing going betwixt them; the two men putting up marks with moss, or pieces of white paper, on a branch of the stools; the one man always going back by the last laid marks, and the valuator always counting and averaging the stools betwixt the newly laid and the late made marks; counting and averaging the stools always as the men go on, taking only twenty, or even ten stools at a time. To*

those who have been in the practice of doing this frequently, it will be found very easy, and will be done very speedily, and with a very considerable degree of accuracy. The proper method of learning to do this correctly is, when a person cuts an oak wood for the first time (or, even were the work repeated several times); he should then, in order to make himself perfectly acquainted with ascertaining the quantity of bark that a stool, or even the stump of a stool will produce, go before the peelers, and select a stool or stem; after having examined it narrowly, he supposes it to produce a certain quantity of bark, and marks this down in his memorandum book. He then causes a person to peel it by itself, dry it, and carefully tie it up and weigh it, and compare it with the weight he supposed it would produce, and he will at once see how far his calculation approaches the truth. A stem of oak, from a natural stool, suppose it to measure in girth two inches, by seven feet long, will contain two solid inches, and one-third of an inch, according to the measurement of Hoppus. This stem or shoot will produce two pounds two ounces of bark. Again, a stem or shoot of natural oak, measuring four inches in girth, by nine feet in length, will be found to contain one solid foot of wood, and will produce thirteen pounds and a half of bark." (*Forester's Guide*, 170.)

3766. *When growing trees are valued*, an allowance is made from their cubic contents for the bark. The rule given by Monteith is, "When the girth or circumference is any thing from twelve inches up to twenty-four inches, then deduct two inches; from twenty-four to thirty-six, three inches; from thirty-six to forty-eight, four inches; from forty-eight to seventy-two, five inches; and above seventy-two, six inches. These deductions," he says, "will be found to answer in almost all trees; unless in such as are very old, and have rough and corky barks, or barks covered with moss, when an extra allowance is to be made." (*Forester's Guide*, 180.)

3767. *In valuing measurable oak-trees*, many persons proceed on the data that every cubic foot of timber will produce a stone (sixteen pounds) of bark. This, Monteith says, "is not always correct;" and he states the following facts from his own experience, with a view to assist beginners in ascertaining the quantity of bark from different trees "An oak-tree, about forty years old, measured down to four inches and a half as the side of the square, and weighing only the bark peeled off the timber that is measured, without including the bark of the spray, &c., every foot of measured timber will produce from nine to eleven pounds of bark. An oak-tree of eighty years old, weighing only the bark peeled off the measurable timber, as above, every foot will produce from ten to thirteen pounds of bark. Every foot of large birch timber, peeled as above, will produce fourteen pounds of bark. Every foot of mountain-ash, as above, will produce eleven pounds and a half of bark. Every foot of the willow, unless a very old one, will produce from nine to eleven pounds of bark. Every foot of larch fir, not exceeding thirty years old, will produce from seven to nine pounds of bark. The bark of trees, particularly the oak, is peeled off, every branch and shoot, down as small as an inch in circumference." (*Forester's Guide*, 189.)

3768. *The price of timber*, like every other article in general use, varies with the supply and demand; and is easily ascertained from the timber-merchants at the different sea-ports; as is that of bark, charcoal, and fire-wood from the tanners and coal-merchants.

3769. *The modes of disposing of timber trees* in common use are, selling the trees standing; by auction; by receiving written proposals; or by bargain and sale; 2d, cutting down the trees, and selling them in the rough, by either of these methods; 3d, converting the fallen trees; that is, cutting them up into the planks or pieces to which they are best adapted, or which are most eligible in the given situation. The first method seems the best, especially on a large scale, and also for the disposal of copse-wood or osier crops.

## CHAP. X.

### *Of the Formation and Management of Orchards.*

3770. *The formation of orchards* is to be considered among the permanent improvements of an estate; and should be kept in view in its first arrangement or laying out. No temporary occupier could afford to plant an orchard without extraordinary encouragement from his landlord. Orchards in this respect may be ranked with timber plantations, and both subjects together agree in belonging equally to agriculture and gardening. Orchards have doubtless existed in Britain for many ages as appendages to wealthy religious establishments; but as objects of farming, or field culture, they do not appear to have been adopted till about the beginning of the seventeenth century (*Lawson*). They were then introduced by Lord Scudamore in Herefordshire, in which county, and



in such parts of those adjoining, as exhibit a red marly soil, are the best farm orchards in England. The chief produce of these orchards is cider and perry; but as these liquors are not in very general demand in this country, and are confessedly less wholesome and nourishing than malt liquors, their formation cannot be carried to any great extent. It seems desirable, however, that orchards of moderate size should be as generally introduced as possible; as the use of the fruit in pies, tarts, and sauces would add considerably to the comforts of the lower classes. Besides, there are some situations, as steep sheltered banks of good soil, which cannot be so profitably employed by any other branch of husbandry. The subject of orchards may be considered in regard to soil and situation, sorts of trees, planting, culture, and the manufacture or disposal of the produce.

#### SECT. I. *Of the Soils and Situations most suitable for Orchards.*

3771. *The sites of all the best apple orchards*, and all the chief cider districts, have been discovered by W. Smith to be on the same stratum of red marl which stretches across the island from Dorsetshire to Yorkshire. Fruit of no kind, indeed, can be raised with much success on a soil that does not contain in its composition a portion of calcareous matter: though apple trees will thrive well on any description of clay which has a dry bottom, and pears and plums on any dry bottomed soil whatever.

3772. *The most desirable aspect* is unquestionably a somewhat elevated and naturally sheltered declivity, open to the south and south-east; but as the author of *The Herefordshire Survey* remarks, orchards are now found "in every aspect, and on soil of every quality, and under every culture." The most approved site, he says, is that which is open to the south-east, and sheltered in other points, but particularly in that opposite. Much however depends on the character of the winds of a country, for in some parts of the island, the west, and in others the east, or north wind, is the most injurious to vegetation.

3773. *The soil* which in Herefordshire is considered best adapted to most kinds of apples, is a deep and rich loam when under the culture of the plough; on this, the trees grow with the greatest luxuriance, and produce the richest fruit. Some trees however, the stire and the golden pippins in particular, form exceptions to this general rule, and flourish most in hot shallow soils on a lime or sandstone. The best sort of pear-trees also prefer the rich loam, but inferior kinds will even flourish where the soil will scarcely produce herbage. An orchard is generally raised with most success and at least expence in a hop yard, the ground under this culture being always well tilled and manured, as well as fenced against every kind of enemy.

3774. *The soils and situations devoted to farm orchards in Scotland* are steep clayey banks sheltered from the more violent and injurious winds; and in whatever part of that country such situations occur, they can scarcely be more profitably employed. Fruit trees of the apple, pear, and cherry kind, especially of the hardier and tall vigorous growing varieties, might be introduced in the hedgerows of dry and moderately sheltered grass-lands in most parts of the British isles. By thus rendering these fruits universal, there would be a considerable accession of enjoyment to the lower classes, and less temptation to break into gardens and orchards.

3775. *The political situation* most desirable for an orchard is of course near a market town; or near a ready conveyance to one; because though the making of cider affords a profit, yet the fruit sold for culinary, or table use, yields a much more considerable one. In *The Gloucestershire Report* it is stated that the fruit, which would fetch 8l. 16s. unground, would only bring in cyder 3l. 15s.

#### SECT. II. *Of the Sorts of Trees and Manner of Planting.*

3776. *The most generally useful fruit* that can be grown in farm orchards is the apple; next the pear; then the plum for tarts, or wine; and to these may be added the cherry, filbert, walnut, chestnut, and elder. In the cider countries where the climate is more certain than in some others, it is customary to plant but a few good sorts; and not to mix above one or two sorts together in making cider; in the northern districts, on the contrary, it is a maxim to plant a considerable number of different sorts, both of those which blossom early and late; because, should the blossom of one variety be destroyed by a frosty wind, that of another may escape. In cold districts, it is advisable to plant orchards in sheltered hollows, exposed to the sun, and to plant thick; but in the warmer southern counties, many descriptions of cider and perry plants may be grown to perfection in the hedge-rows, or as cultured trees in permanent pastures. The fittest trees for such purposes are those which grow tall, with upright shoots, and which bear fruit of a small size; such as the Siberian pippin apple and squash teinton pear: such trees shade the hedges or pastures less than the spreading kinds, and their fruit being small is less likely to be blown down by high winds.

3777. TABLE OF CIDER APPLES OF ESTABLISHED REPUTATION.

No.	Names.	Synonym.	How, when, and where originated, procured, or introduced.	Where figured.	Described.	Size.	Figures.	Color.	Ripe in	Leaf-fall	Consistence, and flavor.	Bearer.	Character of the tree, and general reputation of the fruit.
1.	Siberian pippin		A seedling from Siberian crabs and pears, by Knight		Kn. Tr. 176.	Small	Fla. orbic.	Yellow	Chms.	March	Firm and juicy	Great	Upright sm.-leaved, hardy tree. Specific grav. of juice, 1079, exceeds almost every apple formerly in culture as a cider fruit
2.	Grange pippin		A seedling by Knight, say 1802		Hort. Tr. 4, 229; Kn. Tr. 177.	Small	Roundish	Yellow and red	Oct.	Feb.	Firm, juicy acid	Great	Specific grav. of juice, 1079, exceeds almost every apple formerly in culture as a cider fruit
3.	Foxley		A seedling by Knight, say 1807		Kn. Tr. 177.	Very s.	Roundish	Orange and red	Oct.	Chms.	Firm and juicy	Great	Upright, hardy tree
4.	Siberian Harvey		A new variety by Knight, 1807		Hort. Tr. 4, 229; Kn. Tr. 177.	Small	Round	Bright red and green	Chms.	March	Firm and austere	Indif.	Elegant, upright, sm.-leaved tree
5.	Alban		A seedling by the Rev. T. Alban, of Hereford, in 1798		Kn. Tr. 175.	Small	Round	Red and green	Chms.	Feb.	Firm and very harsh	Indif.	Delicate tree; spec. grav. ju. 1075
6.	Hoghead		A Herefordshire seedling		Forsyth, 77; Kn. Tr. 174.	Small	Roundish	Yellow and red	Chms.	Feb.	Firm and austere	Good	Upright tree; spec. grav. ju. 1075
7.	Stead's kernel		A Herefordshire seedling		Kn. Tr. 174.	Med.	Round	Yellow & russet spots	Jan.	March	Firm and austere	Good	Small-leaved tree; specific gravity of juice, 1074
8.	Large sire		A Herefordshire apple		Forsyth, 96.	Small	Ovate	Yellow and red	Nov.	Feb.	Firm and sharp	Good	An upright, well-kept tree
9.	Breinton seedling		A Herefordshire seedling		Kn. Tr. 172.	Small	Ovate	Yellow and red.	Jan.	March	Firm and juicy	Med.	A free-growing tree in good soil; specific gravity of juice, 1074
10.	Brierly's seedling		A Herefordshire seedling		Kn. Tr. 175.	Small	Round	Yellow	Jan.	March	Firm and austere	Good	A free-growing tree; specific gravity of juice, 1056
11.	Hagleob		An esteemed Herefordshire fruit	Pom. Her. t. 5.	Forsyth, 68.	bel. me.	Conical	Yellow	Jan.	May	Firm and tart	Great	Upright, small-leaved tree
12.	Woodcock		A Herefordshire variety yet in a vigorous state	Pom. Her. t. 10.	Forsyth, 194.	ab. me.	Conical	Dark red and yellow	Jan.	March	Firm and austere	Great	Narrow-leaved, upright tree
13.	Yellow Siberian		From the Siberian crab and Joan's pears, by Knight		Kn. Tr. 175.	Very s.	Round	Very yellow	Jan.	March	Firm, austere	Great	Upright, bands, tree; one of the very best cider apples; specific gravity of juice, 1085
14.	*Maiden's blush				Forsyth, 108.	Small	Roundish	Dark mahogany	Oct.	March	Firm and acid	Good	Hardy, upright growing tree
15.	*New red mast				Forsyth, 119.	Large	Round	Pale red and green	Dec.	Feb.	Firm and acid	Great	Hardy, upright tree; much esteemed in the cider counties
16.	*Old red mast				Forsyth, 131.	Large	Ovate	Pale red and green	Jan.	June	Firm and acid	Great	Fine showy tree; broad leaves
17.	*Redstreak			Pom. Her. t. 4.	Forsyth, 136.	bel. me.	Conical	Greenish yellow	Dec.	May	Firm and sharp	Great	Vigorous tree, broad leaves
18.	*Court pendu			Pom. Her. t. 15.	Forsyth, 136.	bel. me.	Oblong	Green, strk. with red	Jan.	April	Firm and sharp	Good	Vigorous, upright tree
19.	*French crab			Pom. Her. t. 1.	Forsyth, 152.	Med.	Ovate	Deep green and red	Chms.	Chms.	Firm, sharp	Great	Hardy, upright tree; most valuable fruit
20.	*Warwickshire		Resembles the golden pippin.		Forsyth, 49; Hort. Tr. 1, 104.	Large	Round	Good and green	Nov.	March	Firm, aromatic	Good	Delicate slender-twisted tree; fits both for table and cider
21.	*Harvey's				Forsyth, 72.	Large	Ovate	Green russet	Chms.	May	Firm and sweet	Great	Upright tree
22.	*Wine				Forsyth, 186.	Med.	Ovate	Dark russet	Chms.	May	Firm and aromatic	Good	Upright slender tree; esteemed.
23.	*White court				Forsyth, 24.	Bel. m.	Conical	Russet, and some gr.	Jan.	June	Firm and juicy	Good	Upright growing tree; value, fr.
24.	*White court				Forsyth, 183.	Med.	Long	Yellowish	Jan.	March	Firm and sugary	Good	Spreading tree; fruit hangs down
25.	*White court				Forsyth, 183.	Med.	Long	Yellowish	Jan.	March	Firm and sugary	Good	Spreading tree; fruit hangs down
26.	*Devon		Seedling by Knight	Pom. Her. t. 9.	Hort. Tr. 1, 145.	Small	Round	Yellow	Oct.	March	Firm and sweet	Small	Ditto juicy, ranks next golden pippin for dessert and cider
27.	*Brindwood		Seedling by Knight		Hort. Tr. 1, 69.	Small	Round	Reddish green	Sept.	March	Rich and sweet	Good	Hardy tree
28.	Whitmore		Resembles gold-p.		Forsyth, 188.	Large	Round	Strk. white, red & yell.	Nov.	May	Firm, sweet	Good	Jaxurante tree
29.	Yellow impostre		Seedling by Knight		Hort. Tr. 1, 297.	Med.	Round	Yellow	Oct.	Feb.	Firm, juicy	Good	Large handsome tree
30.	Yellow impostre		Seedling by Knight		Hort. Tr. 1, 297.	Med.	Round	Yellow	Oct.	Feb.	Firm, juicy	Good	Large handsome tree
31.	Wormsley		Seedling by Knight		Hort. Tr. 1, 299.	Large	Conical	Yellow and red	Oct.	Feb.	Firm, juicy	Good	Vigorous tree
32.	Elton's yellow kernel			Hook. Pom. t. 22.	Forsyth, 40.	Med.	Round	Yellow and red	Jan.	March	Firm and vinous	Good	Free growing tree
33.	Sykehouse		A Yorkshire apple	Hook. Pom. t. 40.	Forsyth, 168.	Med.	Round	Orange red and yell.	Jan.	April	Firm and juicy	Great	Large spreading tree; showy fr.
34.	Trevender				Forsyth, 182.	Small	Round	Yellow and red	Chms.	May	Firm and juicy	Good	Very upright tree; specific gravity of juice, 1074
35.	Bovey red streak				Forsyth, 12.	Med.	Flat small eye	Deep red and white	Jan.	April	Firm, sub-acid	Good	Free grower; esteemed fruit
36.	Cockage				Forsyth, 92.	Med.	Roundish	Red and yellow	Oct.	Dec.	Soft and sharp	Great	Vigour. tree; fruit good for table, baking, or cider
37.	Minshull crab		A Lancashire seedling, say 1790		Forsyth, 114.	Med.	Roundish	Yel. with brown spots	Sept.	April	Firm, sharp	Great	Upr. vig. tr.; fr. used for every purpose
38.	Red-streak		Seedling of Wiltshire, say 1785		Forsyth, 155.	Med.	Round	Yel-streaked with red	Sept.	Oct.	Soft and acid	Good	Free-growing spreading tree.

3778. *The most approved sorts of cider apples we have enumerated and partially described in the accompanying table (3777).* It will be particularly observed that some of the sorts form much more handsome trees than others, and should therefore be preferred for hedge-rows, and indeed in all cases where the quality of the fruit is not objectionable. Some also have smaller-sized fruit than others, and these are to be preferred for situations exposed to much wind.

3779. *The colors of good cider fruit are red and yellow; the color to be avoided is green, as affording a liquor of the harshest, and generally of the poorest quality.* The pulp should be yellow, and the taste rich and somewhat astringent. Apples of a small size are always, if equal in quality, to be preferred to those of a larger, in order that the rind and kernel, which contain the aromatic part, may be the easier crushed with the pulp.

3780. *The sorts of baking apples most suitable for orchards are the calvilles, of which there are several varieties, including the hawthorndean for early use; the pearmain for autumn use, and the russets for winter and spring.* Many other sorts might be named, but an inspection of the fruit markets will prove that these are the best, and further details belong to books on gardening.

3781. *The dessert apples fit for orchards are the rathripes or Margarets for earliest use; the jenneting, pomroy, summer pearmain, and Kentish for summer use; the golden, downton, and other pippins, especially the ribstone pippin, with the nonpareil and other small russets, for autumn, winter, and spring use.* The following list is given by Nicol as including a fit collection both of kitchen and dessert apples for a private orchard; those marked thus \* being preferable:

Ribstone pippin, \*oslin ditto, \*gogar ditto, \*Kentish ditto, \*royal codling, \*Kentish ditto, \*Carlisle ditto, \*royal russet, Wheeler's ditto, \*royal pearmain, \*loan's ditto (good), \*golden rennet, \*Kentish ditto (good), \*grey leadington, scarlet ditto, summer greening, winter ditto, \*Yorkshire greening, \*margill (very good), Margaret apple (good), \*white hawthorn dean, \*Norfolk beating (good), strawberry, \*purse-mouth (very good).

3782. *The most approved sorts of cider pears are the following:*

Barland, Pom. Her. t. 27., Forsyth, p. 143., fruit very austere, hardy upright tree.  
Holmore, Pom. Her. t. 20., Forsyth, p. 144., upright tree.  
Huffcap, Pom. Her. t. 24., Forsyth, p. 144., fruit austere, large, hardy tree.  
Oldfield, Pom. Her. t. 11., Forsyth, p. 144., large tree.  
Rough cap, Forsyth, p. 144., very austere, hardy free-growing tree.  
Squash teinton, Pom. Her. t. 13., Forsyth, p. 144., fruit very austere, upright tree and great bearer.

3783. In choosing pears for planting in orchards, the description of the plant is a matter of very considerable importance, as pear trees attain a much greater age and size than apples. In our opinion the planting of pears in hedge-rows ought to be more encouraged than the planting of apples, as they are calculated, when dried, to be used in soups; or, when stewed green, to afford a light and agreeable nourishment; and perry is at least a more wholesome and exhilarating liquor to most constitutions than cider.

3784. *The baking and dessert pears fit for orchards, according to Nicol, are the following:*

\*Jargonelle, Crawford or lammas, \*carnock or drummond, \*grey achan, swan egg, \*moorfoal egg, \*yair, \*golden knap, (good), Longueville, \*summer bergamot, \*autumn ditto, \*Scot's ditto, musk robin (good), saffron, \*hanging leaf (very good), the pound pear, cadillac, warden (for baking).

3785. *The best sorts of baking plums are the following:*

Damson, bullace, muscie, winesour, and magnum bonum. which thrives only on a calcareous soil, and grows wild in abundance in the West Riding of Yorkshire.

3786. *The following are excellent dessert plums for an orchard:*

\*Green-gage, Orleans, \*damask (black, good), white perdigron, \*blue ditto, blue gage, \*white magnum bonum, red ditto or imperial, \*drap d'or (yellow, good). Of these the green-gage, orleans, and damask are much the best.

3787. *The cultivation of the plum appears to us deserving of more encouragement than it generally meets with.* Not only does the fruit make excellent pies and tarts, but it may be kept in large quantities, so as to be ready for that purpose at any period of the year. They also make a good wine, and with other fruits and ingredients form one of the best substitutes for port. The damson, bullace, and some other varieties, will grow and bear very high flavored fruit in hedges where the soil is dry below and not too thin. The fruit of the sloe is, for wine making, superior to that of the plum, and nearly as good for tarts.

3788. *The cherry is of more limited culture than any of the foregoing fruits, because chiefly used for eating, and not being of a nature to keep.* Near large towns they may be cultivated to a certain extent. In Kent and Hertfordshire are the cherry orchards which afford the chief supplies for the London market. The sorts are chiefly the caroon, small black or Kentish, the May-duke, and the morella; but Holman's duke, the black heart, and the large gean, will do well in orchards.

3789. *The walnut and Spanish chestnut may be advantageously planted on the outskirts of orchards to shelter them, and a few of them in hedge-rows where the climate is likely to ripen their fruit.* The chestnut can hardly be considered as ripening north of Lon-

don, and the walnut north of Newcastle. Both trees, however, may be planted for their timber in moderately-sheltered situations, in most parts of the British isles.

3790. *The elder* is not beneath notice as an orchard tree. It need seldom be planted as standards; but in unpruned hedges on a soft, deep, and rather rich soil, it yields great quantities of fruit, which is readily manufactured into a sort of wine that is esteemed by many persons when warmed, and forms a comfortable evening draught for the cottager. No tree requires less care; it propagates readily by cuttings or seeds, and requires little or no pruning; but though it will grow in any soil whatever, it will produce no fruit worth mentioning on any but one tolerably deep and rich, and must be cut down when it begins to show indications of age.

3791. *The filbert, currant, gooseberry, raspberry,* and some other fruits, are cultivated extensively near large towns; but the treatment they require renders them in our opinion quite unfit for farm orchards.

3792. *In choosing trees for orchards,* standards, sufficiently tall to admit of horses and cattle grazing under them, should always be preferred. Maiden plants, or such as are only two years for the bud or graft, are the most certain of success; the apples being worked on crab, the pears on wilding, and the cherries on gean stocks. The common baking plums need not be grafted at all, but the better sorts should either be grafted or budded on damson stems. Where budded or grafted chestnuts and walnuts can be got, they should always be preferred as coming much sooner into bearing. The former may be had from the Devonshire nurseries, and some public gardeners about London are now attempting to inarch and bud the walnut.

3793. *With respect to the distance at which orchard trees may be planted,* every thing will depend on the use which is intended to be made of the ground. Where the soil is to be pastured or dug, they may be planted in quincunx and close; but where it is to be ploughed, they should either be planted in rows with sufficient space between for one broad, or two ordinary ridges; or they should be planted in squares to admit of ploughing both east and west, and north and south.

3794. *The Herefordshire orchardists* recommend that the rows should extend from north to south, as in that direction each part of every tree will receive the most equal portions of light and heat. The distance between each row, as well as the space between each tree, should depend on the situation and soil. Where the former is high and exposed, the trees should be closely planted to afford each other protection; and when the latter is poor and shallow, their growth will in course be less luxuriant, and they will consequently require less room. But in low and sheltered situations, and in deep and rich soils, wider intervals should be allowed. In the former instances, twelve yards between each row, and six between each tree, are sufficient; in the latter, twenty-four yards between each row, and eight between each tree, will not be too much.

3795. *As a general guide as to distance,* Nicol states the ultimate space at which apple and pear trees should stand, in a properly planted and close orchard, as from thirty to forty feet, less or more, according to the quality of the soil; taking, as the medium, thirty-six feet. In a poor soil and a bleak exposure, where the trees may not be expected to grow very freely, thirty feet is sufficient; whereas in good soil, and a sheltered situation, forty may not be too much. Cherries and plums may be planted at from twenty-four to thirty-six feet, according to soil and situation, as above, taking, as a medium, thirty feet for the ultimate distance at which they are to stand clear of one another. But it would be advisable, in the first instance, to plant four trees for one that is intended ultimately to remain: planting the proper kinds at the above distances first, and then temporary sorts between them each way. These temporary plants should be of the free growing sorts that begin to bear early; such as the nonsuch and hawthorndean apples, the May-duke cherry, and the Crawford and yair pears; or any others known to produce fruit sooner after planting. These should be considered and be treated as temporary plants from the beginning, and must give place to the principal trees as they advance in growth, by being pruned away bit and bit, and at last stubbed up entirely. In bleak situations, if forest and other hardy trees be planted among the fruit trees, it may not be necessary to plant so many (if any) temporary fruit trees; or these may chiefly consist of the hardier sorts, such as the hawthorndean apple, the May-duke and morella cherries, and the Scotch geans, which produce fruit the soonest.

3796. *In the operation of planting* great care ought to be taken not to insert the plants deeper in the soil than they were before removal. This is a very common error in every description of tree planting; and in retentive soils is ruinous to the tree. Sir C. M. Burrel recommends, as an useful practice, in wet soils, or where the substratum is not suited to the apple or the pear, to plant the trees on hillocks of easy ascent, as for instance one foot higher in the centre than the level of the field, and sloping gradually to that level, for three or four feet every way from the centre. By that practice, the roots will naturally follow the good surface earth; whereas, if they are planted in holes, the roots are apt to shoot into the prejudicial subsoil, to the eventual injury of the plants, by canker and other

diseases. When trees are thus planted on small hillocks, the under-drains may pass between the rows with greater utility.

### SECT. III. *Of the Cultivation of Farm Orchards.*

3797. The trees being *carefully planted, watered, and tied to tall strong stakes*, require little more than common attention for several years. Every autumn or spring they should be looked over, and all cross irregular shoots made during the preceding summer cut out, suckers (if any) removed from their roots, and side growths cleared from their stems.

3798. *The object in pruning young trees*, Nicol observes, is to form a proper head. Generally speaking, the shoots may be pruned in proportion to their lengths, cutting clean away such as cross one another, and fanning the tree out towards the extremities on all sides; thereby keeping it equally poised, and fit to resist the effects of high winds. When it is wished to throw a young tree into a bearing state, which should not be thought of, however, sooner than the third or fourth year after planting, the leading branches should be very little shortened, and the lower or side branches not at all; nor should the knife be used, unless to cut out such shoots as cross one another.

3799. *After an orchard-tree is come into bearing*, Abercrombie says, continue at the time of winter pruning, either every year, or every two, three, or four years, as an occasion is perceived, to cut out unproductive wood, crowded spray, and decayed parts. Also reduce long and outrunning ramblers and low stragglers, cutting them to some good lateral that grows within its limits. Where fruit-spurs are too numerous, then cut the strongest and most unsightly. Also keep the tree pretty open in the middle. If it be necessary to take off large branches from aged trees, use a chisel or saw, and afterwards smooth the wound with a sharp knife. In case old wood is to be cut down to young shoots springing below, to make the separation in summer will be of more advantage to those young shoots, though it is not a common practice, on account of the liability of many stone-fruit bearers to exude gum, when a large branch is lopped in the growing season. Observe to keep the stem clear from all lateral shoots, and eradicate all suckers from the root.

3800. *On aged trees*, that have run into a confusion of shoots and branches, and whose spurs have become clustered and crowded, the saw and the knife may be exercised with freedom; observing to cut clean away all useless spray, rotten stumps, and the like useless excrescences. Thin out the spurs to a moderate consistency, so as to let the air circulate freely among the leaves and fruit in the summer season, and to admit the rays of the sun, so as to give the fruit color and flavor.

3801. *In pruning the apple tree and all other standard trees*, Knight observes, the points of the external branches should be every where rendered thin and pervious to the light, so that the internal parts of the tree may not be wholly shaded by the external parts: the light should penetrate deeply into the tree on every side; but not any where through it. When the pruner has judiciously executed his work, every part of the tree, internal as well as external, will be productive of fruit; and the internal part, in unfavorable seasons, will rather receive protection than injury from the external. A tree thus pruned, will not only produce much more fruit, but will also be able to support a much heavier load of it, without danger of being broken; for any given weight will depress the branch, not simply in proportion to its quantity, but in the compound proportion of its quantity, and of its horizontal distance from the point of suspension, by a mode of action similar to that of the weight on the beam of the steel-yard; and hence a hundred and fifty pounds, suspended at one foot distance from the trunk, will depress the branch which supports it no more than ten pounds at fifteen feet distance would do. Every tree will, therefore, support a larger weight of fruit without danger of being broken in proportion as the parts of such weight are made to approach nearer to its centre.

3802. *Where a tree is stunted, or the head ill shaped*, from being originally badly pruned, or barren from having overborne itself, or from constitutional weakness, the most expeditious remedy is to head down the plant to within three, four, or five eyes (or inches, if an old tree) of the top of the stem, in order to furnish it with a new head. The recovery of a languishing tree, if not too old, will be further promoted by taking it up at the same time, and pruning the roots; for as, on the one hand, the depriving too luxuriant a tree of part even of its sound healthy roots will moderate its vigor; so, on the other, to relieve a stunted or sickly tree of cankered or decayed roots; to prune the extremities of sound roots; and especially to shorten the dangling tap-roots of a plant, affected by a bad subsoil; is, in connection with heading down or very short pruning, the renovation of the soil, and draining, the most availing remedy that can be tried.

3803. *A tree often becomes stunted from an accumulation of moss*, which affects the functions of the bark, and renders the tree unfruitful. This evil is to be removed by scraping the stem and branches of old trees; and on young trees a hard brush will effect

the purpose. Wherever the bark is decayed or cracked, Abercrombie and Forsyth direct its removal. Lyon, of Edinburgh, has lately carried this practice to so great a length as even to recommend the removal of part of the bark of young trees. Practical men, in general, however, confine the operation to cracked bark which nature seems to attempt throwing off; and the effect in rendering the tree more fruitful and luxuriant, is acknowledged by Neill, in his *Account of Scottish Gardening and Orchards*, and by different writers in *The London and Edinburgh Horticultural Transactions*.

3804. *The other diseases to which orchard trees are subject* are chiefly the canker, gum, mildew, and blight, which, as we have already observed, are rather to be prevented by such culture as will induce a healthy state, than to be remedied by topical applications. Too much lime, Sir H. Davy thinks, may bring on the canker, and if so, the replacing a part of such soil with alluvial or vegetable earth, would be of service. The gum, it is said, may be *constitutional*, arising from offensive matter in the soil; or *local*, arising from external injury. In the former case, improve the soil; in the latter, apply the knife. The mildew, it is observed by T. A. Knight and Abercrombie, "may be easily subdued at its appearance, by scattering flour of sulphur upon the infected parts." As this disease is now generally considered the growth of parasitical fungi, the above remedy is likely to succeed. For the *blight* and *caterpillars*, Forsyth recommends burning of rotten wood, weeds, potatoe haulm, wet straw, &c. on the windward side of the trees when they are in blossom. He also recommends washing the stems and branches of all orchard trees with a mixture of "fresh cow-dung with urine and soap-suds, as a whitewasher would wash the ceiling or walls of a room." The promised advantages are, destruction of insects and "fine bark;" more especially, he adds, "when you see it necessary to take all the outer bark off."

3805. *With the Herefordshire orchardists pruning* is not in general use; the most approved method is that of rendering thin and pervious to the light, the points of the external branches, so that the internal branches of the tree may not be wholly shaded by the external parts. Large branches should rarely or never be amputated. The instrument generally used for the purpose of pruning, is a strong flat chisel, fixed to a handle six feet or more in length, having a sharp edge on one of its sides, and a hook on the other. (*Knight's Treatise on the Apple and Pear*.)

3806. *The culture of the soil among orchard trees* is always attended with advantage; though it can so seldom be properly conducted in farm orchards, that in most cases it is better to lay them down with grass seeds for pasture. To plough between the trees and take corn crops, even if manure is regularly given, cannot be any great advantage unless a space of six or eight feet radius is left round each tree. If such a space is left, and yearly dug but not cropped, the trees will thrive well; and a ridge between each two rows may be sown with corn. The greater number of orchards in Herefordshire and Gloucestershire are under pasture; but the most productive are those trees grown in hop grounds. In Kent, in some instances, the interspaces of young orchards are occupied by hops, in others by filberts, and in grown orchards the latter are sometimes seen. Some old orchards are likewise in permanent sward, others under arable or garden crops, and some in saintfoin, while others are in lucern.

#### SECT. IV. *Of the Gathering and Keeping of Orchard Fruits.*

3807. *The gathering of orchard fruits*, and especially apples, should be performed in such a manner as not to damage the branches, or break off the fruit spurs or buds. Too frequently the fruit is allowed to drop, or they are beat and bruised by shaking the tree and using long poles, &c. Nicol directs that they should never be allowed to drop of themselves, nor should they be shaken down, but should be pulled by the hand. This may be thought too troublesome a method; but every body knows that bruised fruit will not keep, nor will it bring a full price. The expense of gathering, therefore, may be more than defrayed, if carefully done, by saving the fruit from blemish.

3808. *With regard to keeping of kernel fruits*, the old practice, and that recommended by Marshal and Forsyth, commences with sweating, though Nicol, and other modern gardeners, omit this process. Marshal, the author of *An Introduction to Gardening*, observes that those fruits which continue long for use should be suffered to hang late, even to November, if the frost will permit, for they must be well ripened, or they will shrink. Lay them on heaps till they have sweated a few days, when they must be wiped dry. Let them then lay singly, or at least thinly, for about a fortnight, and be again wiped, and immediately packed in boxes and hampers, lined with double or treble sheets of paper. Place them gently in, and cover them close, so as to keep air out as much as possible. Preserve them from frost through the winter. Never use hay for the purpose. Kernel fruits and nuts keep no where better than when mixed and covered with sand in a dry cool cellar in the manner of potatoes. Buried in pits well protected from moisture, russets have been found to keep perfectly fresh a year from the time of their being gathered. The keeping of cider fruits is not approved of, it being found best to

crush them after they have been thinly spread for a few days on a dry boarded floor. Many of the Herefordshire growers carry them direct from the tree to the crushing mill.

#### SECT. V. *Of the Manufacture of Cider.*

3809. *Cider is commonly manufactured by the grower of the fruit, though it would certainly be better for the public if it were made a distinct branch of business like brewing or distilling.* "The true way to have excellent cider," Marshal observes, "is to dispose of the fruit to professional cider makers. The principal part of the prime cider, sold in London and elsewhere, is manufactured by professional men; by men who make a business of manufacturing and rectifying cider; even as distillers, rectifiers of spirit, and brewers, follow their businesses or professions; and like them too conduct their operations, more or less, on scientific principles." (*Rev. of Agr. Rep.* vol. ii. p. 294.) It is allowed on all hands that the operation is most slovenly performed by the farmer, and that it is very difficult to procure this liquor in good quality. The operation of cider making is as simple as that of wine making or brewing, and will be perfectly understood from the following directions, chiefly drawn from the treatises of Crocker and Knight, that any person possessing an orchard, or a few hedge-row fruit trees, may make a supply for his own use. The first business is the gathering and preparation of the fruit; the second, grinding and pressing; and the last, fermenting and bottling.

3810. *In gathering cider apples, care should be taken that they be thoroughly ripe before they are taken from the tree; otherwise the cider will be of a rough harsh taste, in spite of all the endeavors of the operator.* It is observed by Crocker, in his tract on *The Art of Making and Managing Cider*, that the most certain indications of the ripeness of apples, is the fragrance of their smell, and their spontaneously dropping from the trees. When they are in this state of maturity, in a dry day, the limbs may, he says, be slightly shaken, and partly disburdened of their golden store; thus taking such apples only as are ripe, and leaving the unripe longer on the trees, that they may also acquire a due degree of maturity. It may not, he thinks, be amiss to make three gatherings of the crop, keeping each by itself. The latter gathering, as well as wind-falls, can however only be employed in making inferior cider: the prime cider must be drawn from the former gatherings.

3811. *On the proper mixture of fruits, or rather on their proper separation, the merit of cider will always greatly depend.* Those whose rinds and pulp are tinged with green, or red without any mixture of yellow, as that color will disappear in the first stages of fermentation, should be carefully kept apart from such as are yellow, or yellow intermixed with red. The latter kinds, which should remain on the trees till ripe enough to fall without being much shaken, are alone capable of making fine cider. Each kind should be collected separately, as noticed above, and kept till it becomes perfectly mellow. For this purpose, in the common practice of the country, they are placed in heaps of ten inches or a foot thick, and exposed to the sun and air, and rain; not being ever covered, except in very severe frosts. The strength and flavor of the future liquor are increased by keeping the fruit under cover some time before it is ground; but unless a situation can be afforded it, in which it is exposed to a free current of air, and where it can be spread very thin, it is apt to contract an unpleasant smell, which will much affect the cider produced from it. Few farms are provided with proper buildings for this purpose on a large scale, and the improvement of the liquor will not nearly pay the expense of erecting them. It may reasonably be supposed, that much water is absorbed by the fruit in a rainy season; but the quantity of juice yielded by any given quantity of fruit will be found to diminish as it becomes more mellow, even in very wet weather, provided it be ground when thoroughly dry. The advantages, therefore, of covering the fruit will probably be much less than may at first sight be expected. No criterion appears to be known, by which the most proper point of maturity in the fruit can be ascertained with accuracy; but it improves as long as it continues to acquire a deeper shade of yellow. Each heap should be examined prior to its being ground, and any decayed or green fruit carefully taken away. The expense of this will be very small, and will be amply repaid by the excellence of the liquor, and the ease with which too great a degree of fermentation may be prevented. (*Crocker.*)

3812. *In grinding the apples into pommage, several methods are practised; but the two most chiefly in use are by the bruising-stone with a circular trough (fig. 462.), and the apple-mill.* In the trough, the apples are thrown in and bruised by the motion of the stone, as it is moved round by a horse, in the way that tanners grind bark. This is an ancient method, and still in use in some parts of Devonshire; and although it has its inconveniences in bruising some apples too much and some too little, it is not without its advocates in those parts of the country, the inhabitants of which allege that it bruises the kernels of the fruit better than other machines.

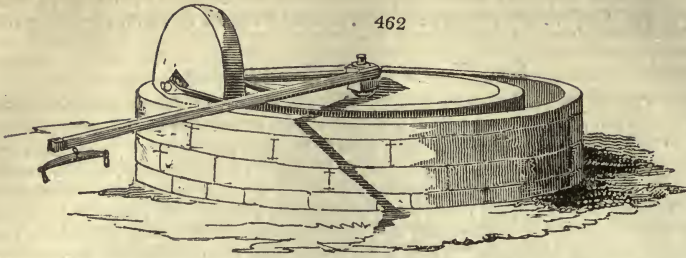

3813. *The apple-mill* is an iron machine. Where iron-mills have been tried, this metal has been found to be soluble in the acid of apples, to which it communicates a brown color and an unpleasant taste. No combination has been ascertained to take place between this acid and lead; but as the calx of this metal readily dissolves in, and communicates an extremely poisonous quality to, the acetous juice of the apple, it should never be suffered to come into contact with the fruit or liquor. (*Knight on the Apple and Pear.*)

3814. *Whether the pommage should immediately after grinding be conveyed to the press*, there to be formed into a kind of cake, or what is called the cheese; or whether it should remain some time in that state before pressing, ciderists have not agreed. Some say it should be pressed immediately after grinding; others conceive it best to suffer it to remain in the grinding-trough, or in vats employed for the purpose, for twenty-four hours, or even two days, that it may acquire not only a redness of color, but also that it may form an extract with the rind and kernels. Both extremes are, Crocker thinks, wrong. There is an analogy, he says, between the making of cider from apples, and wine from grapes; and the method which the wine-maker pursues ought to be followed by the cider-maker. When the pulp of the grapes has lain some time in the vats, the vintager thrusts his hand into the pulp, and takes some from the middle of the mass; and when he perceives, by the smell, that the luscious sweetness is gone off, and that his nose is affected with a slight piquancy, he immediately carries it to the press, and by a light pressure expresses his prime juice. In like manner, should the ciderist determine the time when his pulp should be carried to the press. If he carry it immediately from the mill to the press, he might lose some small advantage which may be expected from the rind and kernels, and his liquor may be of lower color than he might wish. If he suffer it to remain too long unpressed, he will find to his cost that the acetous fermentation will come on before the vinous is perfected, especially in the early part of the cider-making season. He will generally find that his pulp is in a fit state for pressing in about twelve or sixteen hours. If he must of necessity keep it in that state longer, he will find a sensible heat therein, which will engender a premature fermentation; and he must not delay turning it over, thereby to expose the middle of the mass to the influence of the atmosphere. Knight's opinion is, however, that it should remain twenty-four hours before it is taken to the press.

3815. *The pommage being carried to the press*, and a square cake or cheese made of it, by placing very clean sweet straw or reed between the various layers of pommage; or by putting the same into the hair-cloths, and placing them one on another. It is of importance that the straw or weed be sweet, and perfectly free from any fustiness, lest the cider be impregnated therewith. Particular care ought also to be taken to keep hair-cloths sweet, by frequently washing and drying, or the ill effects of their acidity will be communicated to the cider. To this cake or cheese, after standing awhile, a slight pressure is at first to be given, which must be gradually increased until all the must or juice is expressed; after which, this juice must be strained through a coarse hair-sieve, to keep back the gross feculencies of the juice, and be put into proper vessels. These vessels may be either open vats or close casks; but as, in the time of a plentiful crop of apples, a number of open vats may by the ciderist be considered an incumbrance in his cider-rooms, they should be generally carried immediately from the press to the cask. Thus far, says Crocker, cider-making is a mere manual operation, performed with very little skill in the operator; but here it is that the great art of making good cider commences; nature soon begins to work a wonderful change in this foul-looking, turbid, fulsome, and unwholesome fluid; and, by the process of fermentation alone, converts it into a wholesome, vinous, salubrious, heart-cheering beverage.

3816. *Fermentation* is an intestine motion of the parts of a fermentable body. This motion, in the present case, is always accompanied with an evident ebullition, the bubbles rising to the surface, and there forming a scum or soft and spongy crust, over the whole liquor. This crust is frequently raised and broken by the air as it disengages itself from the liquor, and forces its way through it. This effect continues whilst the



fermentation is brisk, but at last gradually ceases. The liquor now appears tolerably clear to the eye, and has a piquant vinous sharpness upon the tongue. If in this state the least hissing noise be heard in the fermenting liquor, the room is too warm, and atmospheric air must be let in at the doors and at the windows. Now, continues Crocker, is the critical moment which the ciderist must not lose sight of; for, if he would have a strong, generous, and pleasant liquor, all further sensible fermentation must be stopped. This is best done by racking off the pure part into open vessels, which must be placed in a more cool situation for a day or two; after which it may again be barrelled, and placed in some moderately-cool situation for the winter. The Herefordshire cider-farmers, after the cider has perfected its vinous fermentation, place their casks of cider in open sheds throughout the winter; and, when the spring advances, give the last racking, and then cellar it. In racking, it is advisable that the stream from the racking-cock be small, and that the receiving-tub be but a small depth below the cock, lest, by exciting a violent motion of the parts of the liquor, another fermentation be brought up. The feculence of the cider may be strained through a filtering-bag, and placed among the second-rate ciders; but by no means should it be returned to the prime cider. In this situation the cider will, in course of time, by a sort of insensible fermentation, not only drop the remainder of its gross lees, but will become transparent, highly vinous, and fragrant.

3817. *According to Knight*, after the fermentation has ceased, and the liquor is become clear and bright, it should instantly be drawn off, and not suffered on any account again to mingle with its lees; for these possess much the same properties as yeast, and would inevitably bring on a second fermentation. The best criterion to judge of the proper moment to rack off will be, the brightness of the liquor; and this is always attended with external marks, which serve as guides to the cider-maker. The discharge of fixed air, which always attends the progress of fermentation, has entirely ceased; and a thick crust, formed of fragments of the reduced pulp, raised by the buoyant air it contains, is collected on the surface. The clear liquor being drawn off into another cask, the lees are put into small bags, similar to those used for jellies: through these whatever liquor the lees contain gradually filtrates, becoming perfectly bright; and it is then returned to that in the cask, in which it has the effect, in some measure, of preventing a second fermentation. It appears to have undergone a considerable change in the process of filtration. Its color is remarkably deep, its taste harsh and flat, and it has a strong tendency to become acetous; probably by having given out fixed and absorbed vital air. Should it become acetous, which it will frequently do in forty-eight hours, it must not on any account be put into the cask. If the cider, after being racked off, remains bright and quiet, nothing more is to be done to it till the succeeding spring; but if a scum collects on the surface, it must immediately be racked off into another cask; as this would produce bad effects if suffered to sink. If a disposition to ferment with violence again appears, it will be necessary to rack off from one cask to another, as often as a hissing noise is heard. The strength of cider is much reduced by being frequently racked off; but this arises only from a larger portion of sugar remaining unchanged, which adds to the sweetness at the expense of the other quality. The juice of those fruits, which produce very strong ciders, often remains muddy during the whole winter, and much attention must frequently be paid to prevent an excess of fermentation.

3818. *The casks, into which the liquor is put* whenever racked off, should always have been thoroughly scalded, and dried again; and each should want several galls of being full, to expose a larger surface to the air.

3819. *The above precautions* neglected by the ciderist, the inevitable consequence will be this: Another fermentation will quickly succeed, and convert the fine vinous liquor he was possessed of into a sort of vinegar; and all the art he is master of will never restore it to its former richness and purity. When the acetous fermentation has been suffered to come on, the following attempts may be made to prevent the ill effects of it from running to their full extent. A bottle of French brandy; half a gallon of spirit extracted from the lees of cider; or a pail-full of old cider, poured into the hogshead soon after the acetous fermentation is begun: but no wonder if all these should fail, if the cider be still continued in a close warm cellar. To give effect to either, it is necessary that the liquor be as much exposed to a cooler air as conveniently may be, and that for a considerable length of time. By such means it is possible fermentation may, in a great measure, be repressed: and if a cask of prime cider cannot from thence be obtained, a cask of tolerable second-rate kind may. These remedies are innocent: but if the farmer or cider-merchant attempt to cover the accident, occasioned by negligence or inattention, by applying any preparation of lead, let him reflect, that he is about to commit an absolute and unqualified murder on those whose lot it may be to drink his poisonous draught.

3820. *Stumming*, which signifies the fuming a cask with burning sulphur, may sometimes be advantageous. It is thus performed: Take a stripe of canvas cloth, about twelve

inches long and two broad; let it be dipped into melted brimstone: when this match is dry, let it be lighted, and suspended from the bung of a cask (in which there are a few gallons of cider) until it be burnt out. The cask must remain stopped for an hour or more, and be then rolled to and fro, to incorporate the fumes of the match with the cider; after which it may be filled. If the stumming be designed only to suppress some slight, improper fermentation, the brimstone-match is sufficient; but if it be required to give any additional flavor to the cider, some powdered ginger, cloves, or cinnamon, &c. may be strewed on the match when it is made. The burning these ingredients with the sulphur will convey somewhat of their fragrance to the whole cask of cider; but to do it to the best advantage, it must be performed as soon as the vinous fermentation is fully perfected.

3821. *Cider is generally in the best state to be put into the bottle at two years old, where it will soon become brisk and sparkling; and if it possesses much richness, it will remain with scarcely any sensible change during twenty or thirty years, or as long as the cork duly performs its office.*

3822. *In making cider for the common use of the farm-house, few of the foregoing rules are attended to. The flavor of the liquor is here a secondary consideration with the farmer, whose first object must be to obtain a large quantity at a small expense. The apples are usually ground as soon as they become moderately ripe; and the juice is either racked off at once as soon as it becomes bright, or more frequently conveyed from the press immediately to the cellar. A violent fermentation soon commences, and continues until nearly the whole of the saccharine part is decomposed. The casks are filled up and stopped early in the succeeding spring, and no further attention is either paid or required. The liquor thus prepared may be kept from two to five or six years in the cask, according to its strength. It is generally harsh and rough, but rarely acetous; and in this state, it is usually supposed to be preferred by the farmers and peasantry. When it has become extremely thin and harsh by excess of fermentation, the addition of a small quantity of bruised wheat, or slices of toasted bread, or any other farinaceous substance, will much diminish its disposition to become sour.*

3823. *The produce of cider or perry by the acre, can only be guessed at, by first ascertaining the number of trees. From an orchard of trees, in full bearing, half a hogshead of cider may, in seasons ordinarily favorable, be expected from the fruit of each tree. As the number of trees on the acre varies from ten to forty, the quantity of cider must vary in the same proportion, that is, from five to twenty hogsheads. Pear-trees, in equally good bearing, yield fully one-third more liquor: therefore, although the liquor extracted from pears sells at a lower price than that produced from apples, yet the value by the acre, when the number of trees is the same, is nearly on a par.*

#### SECT. VI. *Of the Machinery and Utensils necessary for Cider making.*

3824. *The machinery of the common ciderist, includes the mill-house, mill, press, cloth, vat, and cask, with their appurtenances.*

3825. *Marshal, in The Rural Economy of Gloucestershire, remarks, that a mill-house, on an orchard-farm, is as necessary as a barn. It is generally one end of an out-building; or, perhaps, an open shed, under which straw or small implements are occasionally laid up. The smallest dimensions, to render it any way convenient, are twenty-four feet by twenty; a floor thrown over it, at seven feet high; a door in the middle of the front, and a window opposite; with the mill on one side, the press on the other side of the window; as much room being left in front, towards the door, for fruit and utensils, as the nature of the mill and the press will allow. The utensils belonging to a mill-house are few: the fruit is brought in carts or baskets, and the liquor carried out in pails.*

3826. *Of the common cider mill (fig. 462.), there are several varieties formed on the principles of the bark mills of tanners. The circle enclosed by the trough is sometimes divided into compartments for containing different varieties of the same fruit (fig. 463.) The size of the runner varies from two and a half to four and a half feet diameter, and from nine to twelve inches in thickness; which, in general, is even, like that of a grindstone, not varying, like that of a millstone: the weight one or two tons.*

*The bottom of the chase is somewhat wider than the runner, that this may run freely. The inner side rises perpendicularly, but the outer side spreads, so as to make the top of the trough some six or eight inches wider than the bottom: to give freedom to the runner, and room to scatter in the fruit, stir it up while grinding, and take out the ground matter. The depth, nine or ten inches. The outer rim of the trough is three or four inches wide; and the diameter of the inner circle, which the trough circumscribes, from four and a half to five feet, according to the size of the mill. This is sometimes raised by a table of thick plank fixed upon the stone, with a curb of wood, lessening to an angle, fixed upon the circumference of the trough, making the whole depth of the trough about equal to its width at the bottom. This lessens the quantity of the stone; and the plank upon the centre answers other purposes. The entire bed of a middle-sized mill is about nine feet, some ten, and some few twelve, feet in diameter; the whole being composed of two, three, or four stones, cramped together as one; and worked, or at least finished, after they are cramped together. The best stones are raised in the forest of Dean: they are mostly a dark-red gritstone (non-calcareous), working with sufficient freedom, yet sufficiently hard for this intention.*

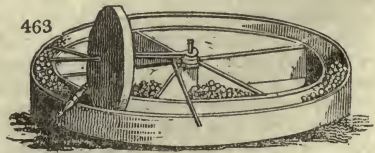

The bed of the mill is formed, and the trough partly hollowed, at the quarry; leaving a few inches at the edge of each stone uncut out, as a bond to prevent its breaking in carriage. Much depends on the quality of the stone. It ought not to be calcareous, in whole or in part, as the acid of the liquor would corrode it. Some of the Herefordshire stones have calcareous pebbles in them, which being of course dissolved, leave holes in the stone. Nor should it be such as will communicate a disagreeable tinge to the liquor. A cleaned-grained grindstone grit is the fittest for this purpose.

3827. *The runner*, as has been seen (fig. 463.), is moved by means of an axle passing through the centre, with a long arm, reaching without the bed of the mill, for a horse to draw by; and with a short one passing to an upright swivel, turning upon a pivot, in the centre of the stone, and steadied at the top, by entering a bearing of the floor above. An iron bolt, with a large head, passes through an eye in the lower part of the swivel, into the end of the inner arm of the axis. Thus the requisite double motion is obtained, and the stone kept perfectly upright (which it ought to be) with great simplicity, and without stress to any part of the machine. This is the ordinary method of hanging the runner. There is a more complex way of doing it, but Marshal says, he sees no advantage arising from it. There are some mills, it seems, with two runners, one opposite the other. On the inner arm of the axis, about a foot from the runner, is fixed (or ought to be, though it is frequently wanting) a cogged wheel working in a circle of cogs, fixed upon the bed of the mill.

3828. *The diameter of the wheel* is determined by the height of the axis above the bed of the mill. The diameter of the ring of cogs, by the distance of the wheel from the centre of motion. The use of these wheels is to prevent the runner from sliding, to which it is liable when the mill is full; the matter, when nearly ground, rising up in a body before the stone. Besides, by assisting the rotatory motion of the stone, it renders the work more easy to the horse. These wheels require to be made with great exactness; and in a country where carpenters are unaccustomed to them, a mill-wright should be employed in fixing them. The situation of the mill is such as to leave a horse-path, about three feet wide, between the bed and the walls; so that a moderately sized mill, with its horse-path, takes up a space of fourteen or fifteen feet every way.

3829. *A cider mill in use in the south of France* (fig. 464.), is worked on a circular platform of boards, and instead of stone the wheel or conical roller (a) is of cast-iron. The fruit is spread thinly over the platform, and the roller moved round by one man or a woman. From the rollers covering more breadth than the narrow bark wheels in use in England, more fruit is crushed in a short time by this sort of mill, than would at first sight be supposed.

3830. *An eligible description of mill*, where cider is only made for private use, consists of a pair of fluted rollers working into each other. These rollers are of cast-iron, hollow, about nine inches diameter, with flutes or teeth, about an inch wide, and nearly as much deep. In general they are worked by hand, two men working against each other. Between these the fruit passes twice; the rollers being first set wide, to break it into fragments, and afterwards closer to reduce the fragments, and the seeds; the bruising of the latter, being of essential use in making high-flavored cider.

3831. *The cider press* is made on the principle of the common packing press, and therefore requires no particular description. On a small scale the cheese-press will answer every purpose.

3832. *Cider cloths* are used for containing the pommage in order to its being pressed. They are usually made of common hair-cloth; but such as is rather close in its texture is the best. The size is generally about four feet square; and they hold about two or three bushels, or as much as the mill can grind at once: and these are heaped over each other till the press is full. The larger presses will hold from eight to fifteen bags, which yield from one to two hundred gallons of liquor, according to the largeness of what is termed the cheese. To perform the work neatly, it is necessary to have two sets of these bags; for they clog and fur in pressing, and consequently become unfit for use till they have been washed and dried; so that, while this is doing, either the press must stand still, or another set be ready to employ it. But some, instead of hair bags, lay long straw under the pommage, the ends of which they turn up over it; then cover the pommage entirely with fresh clean straw, upon which they spread another layer of pommage: and so on, alternately, till the press is full. Either of the methods will do; but those who are desirous of doing the work in the neatest and best manner, generally use bags.

3833. *The cider-vat* is a vessel made for the purpose of receiving the pommage, or the cider before it is racked off into the cask. Vessels of this kind should be made of wood, as where lead is employed, it is liable to be corroded by the malic acid.

3834. *Cider casks* are the vessels employed for the keeping of the liquor. The choice of proper vessels to keep the cider in after it has fermented is very material, no liquor being so apt as this to take the taste or twang of the cask. New vessels, though the wood be ever so well seasoned, are apt to give a disagreeable relish to all liquors, and remarkably so to cider, unless due caution be used beforehand. Frequent scalding with hot water, into which some handfull of salt have been first thrown, or with water in which some of the pommage has been boiled, and washing afterwards with cider, are the usual remedies against this evil, and seldom fail of removing it effectually. Of old casks, beer-vessels are the worst, as they always spoil cider; and, in return, cider-casks infallibly spoil beer. Wine and brandy casks do very well, provided the tartar adhering to their sides be carefully scraped off, and they are well scalded.

464

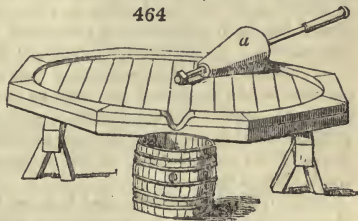

## CHAP. XI.

*Of the Laying Out of Farm and other Culturable Lands.*

3835. *The farming lands of an estate* are in general the grand source of its annual rental. The demesne lands are chiefly for enjoyment; the roads afford no direct income; the villages, manufactories, commonly the mines and fisheries, and often also the woods, yield no income of consequence; but there remains the lands to be let out to the professional farmer, market gardener, nurseryman, and cottagers; from these the landlord generally derives his principal return for the capital laid out on the estate. Having therefore disposed of all the other parts of the territory, it remains only to arrange the farming or culturable lands in farms of different characters and sizes, in cottage lands, gardens, or orchard grounds: these may be considered in regard to their extent and arrangement.

SECT. I. *Of the Extent or Size of Farm and Cottage Lands.*

3836. *The proper size of farms*, or of land to be let in any way, must necessarily be that which best suits the markets: not altogether the market of the moment, for there may be a run for large or for small farms; but the market on an average of years, times, and circumstances. If small farms and cottages, with minute portions of land attached, will bring higher rents than larger possessions, then unquestionably the landlord does well to arrange his territory in this way; unless it can be proved that a dealer in land has not the same right over his own property as a dealer in any other commodity. But it has been said by some that small, and by others that large farms are injurious to the country. Admitting for a moment that either was the case, will any man assert that an individual is to forego his own just advantage, for the sake of the public? Such a doctrine would be absurd, and lead to the most ruinous consequences to society, as might easily be proved by supposing a general extension of the principle of preferring the public benefit to one's own private advantage. — On this subject we submit the sentiments of the able author of the article *Agriculture*, in the *Supp. to the Encyc. Brit.*, already often quoted.

3837. *The various objections to large farms*, which were urged by Dr. Price, Lord Kaimes, and most of the economical writers of the last century, we have not here room to examine. Much stronger reasons, certainly, than any that have been hitherto advanced, must be required to justify the interference of the legislature with the rights of the agricultural classes — with that of a landholder to draw the greatest revenue from his property, and with that of a farmer to extend his concerns as far as his capital and abilities will permit. Even though it should be conceded to Dr. Price, that a given extent of land yields a greater produce in the hands of several small farmers than of one great farmer, it still remains to inquire, what part of that produce can be spared for the general consumption? — and whether the labor of these people might not be employed with more advantage than on such minute portions of land, as yield, even in the best seasons, little more than food for their own subsistence? In Britain, of which the families employed in agriculture are to those of the whole population only as one to 2·84, and in which the proportion of lands cultivated, or that may be cultivated, is not four acres to every individual, the great object ought certainly to be, to increase the disposable produce of the country for the supply of the general population.

3838. *The grand objection to large farms*, that they depopulate the country, is not supported by facts. The population of the country has not only greatly increased since the enlargement of farms, but, in the ten years from 1801 to 1811, this increase appears to have been only two *per cent.* less than that of the town population. The fact is, that the increase of the rural population has been in a greater ratio than that of the town population, in those counties, such as Northumberland, where very large farms abound; and where, indeed, as is usually the case, this state of things is combined with a spirited and productive system of agriculture. Even in Lancashire, the ratio of increase is only two *per cent.* in favour of the towns; but no one will ascribe this to the enlargement of farms. The truth seems to be, that, wherever agriculture has made the greatest progress, whatever may be the size of the farms, the increase of employment has been attended with a corresponding increase of population; and that the ratio of increase has been kept down below that of towns, by no other causes than the stationary condition or slow progress of agriculture in some parts, and the superior allurements of manufactures and commerce in others. It is further to be remarked, that, throughout the whole of the arable districts of Scotland, the number of people is proportionably greater on large than on small farms. The number of hands required on the former is too great to be lodged in the farmer's own house; and, therefore, on all such farms, cottages are built for their residence. These cottages are generally inhabited by married men, whose families find employment in hoeing green crops, and other easy work, from a very early age. In the less improved counties, on the other hand, where small farms still prevail,

unmarried servants are preferred, as, on such farms, there is little or no employment for the families of married servants. Our limits do not permit us to enquire how far the poor laws of England operate against the employment of married servants, living in cottages on every farm; but the happy effects of this arrangement are manifest in the south-eastern counties of Scotland, as we shall notice immediately.

3839. *Cottage farms.* The possession of land is held by some writers to be so important, with a view to the comforts of the laboring classes, as well as to the increase of the rural population, that they have not been contented with objecting to large farms, but have proceeded to recommend what are called cottage farms, for country laborers generally. Of this plan we might say at once, that it must be limited every where by the demand for labor; and that, wherever such small allotments are required by the state of agriculture, they will gradually be formed from motives of interest, without the necessity of any higher control. They are at this time common in many parts of Britain; and a different system has been established in other parts, for no other reason than because of its superior advantages to all concerned. Yet, as cottage-farms bear a very plausible appearance in the eye of speculative men, it seems necessary to offer some further remarks on a question which has been so often agitated.

3840. *If every laborer had a comfortable cottage, and four acres of land at a moderate rent,* as recommended by some of the correspondents of the Board of Agriculture, there is reason to believe that his condition might be much improved for a few years, supposing his demand for labor to continue the same as at present. Even the colonies which this class would every year send forth in quest of new cottages might be supplied for a time; and though the wages of labor must sink very fast, still this premium might enable the laborers to multiply with little interruption for several generations. At last, however, the multiplication of cottage-farms must necessarily stop, and a great proportion of the people, without land and without the means of employment, would either sink into helpless misery, or be driven by despair to the commission of every species of enormity. Such was the state of England at the breaking up of the feudal system, the policy of which also was to increase the number of the people, without regard to the means of their employment; and such, though in a much less degree, is the present state of those parts of the united kingdom in which cottage-farms are the most prevalent. The whole question, we think, is capable of being most satisfactorily decided, by an appeal to the plain mercantile criterion of rent. If a hundred laborers, each of them possessing four acres, can pay a higher rent than one farmer can pay for the whole four hundred, buildings, fences, and repairs being estimated, we can see no reason why they should not be preferred; but if this be not the case, we are greatly at a loss to conceive with what justice landholders can be called upon to submit to sacrifices which no other class of the community is ever expected to make. We might, with just as much reason and justice, require a manufacturer to employ a certain number of hands in proportion to the amount of his capital, however unprofitable to him might be their labor.

3841. *There are two sorts of cottages occupied by two distinct classes of laborers in all our best agricultural counties.* Of the first sort are the small agricultural villages, where those mechanics and other laborers reside, who could not find full employment on any one farm. To such men small farms are advantageous, or otherwise, according to the nature and the constancy of their employment. The other class of cottagers, to which we have already alluded, are ploughmen and other servants employed throughout the year on a particular farm. To these men small possessions of land are almost as unsuitable as they would be to a country gentleman's domestics. But a small garden is usually attached to each cottage; and they are also allowed to keep a cow, as part of their wages — not upon any particular spot of their own, but along with their master's cows. Their fuel is carried home by their masters' teams, and a part of his own field, ready dressed, is assigned them for raising potatoes, flax, or other crops for their families. Thus, with little risk from the seasons or markets, and without any other demand on their time than a few leisure hours will satisfy, these people enjoy all the advantages which the occupancy of land can confer on a laborer. And there is not a more useful, we may also add, a more comfortable body of men among the industrious classes of society. To give this class of laborers four acres of land, along with every cottage, would be to render them bad servants, and worse farmers; and either a nuisance to the person on whose farm they reside, or his abject dependants for employment. The only proper residence for men who do not choose to engage, or are not wanted, as constant laborers, is in such central agricultural villages as we have just mentioned, and not on separate farms, where they are excluded from the general market for labor.

3842. *Of all the witnesses examined before the late committees of parliament on the corn laws,* there is only one whose sentiments are opposed to the general feeling of all well informed men, regarding the advantages that have resulted from the enlargement of farms. We shall, therefore, content ourselves with noticing what appears to be the natural progress in the size of farms; the circumstances which prevent any possible en-

largement of them from ever becoming injurious to the public, and the influence which perfect liberty in this respect has excited in the improvement of our agriculture.

3843. *During the feudal system*, that part of an estate which was not cultivated under the direction of the proprietor himself, was let out in small allotments to his vassals, from whom he received military or other services, or a portion of the produce, in return. In these times of turbulence and ferocity, the power of the chief mainly depended on the number of his tenants; and it was therefore his policy to increase them as much as possible, by dividing his land into very small possessions. That they might assist one another in their rural labors, and in repelling the incursions to which they were incessantly exposed, these tenants were collected in a village near the castle of their lord. A certain extent of arable land was appropriated to it, on which they raised corn, and a much larger tract of waste or wood land, where their live stock pastured in common. Spirited cultivation could never be introduced into this system of occupancy; nothing more than the means of subsistence was sought by the tenantry, and power, not revenue, was the great object of the landholder.

3844. *After the fall of the feudal system*, this arrangement continued to prevail with little alteration for a long period; its vestiges are still to be traced in every part of Britain; and it exists in several counties, though in a modified form, even at the present time. The common fields and commons of England, and the *infield* and *outfield* divisions of Scotland, did not originate in any regard for the welfare of the lower classes, to whom the tenancy of land is now thought to be so necessary, but in the anarchy and oppression of those dark ages in which all the landed property of the island was engrossed by a few great barons. When these petty sovereigns were at last overthrown, and when commerce and the arts held up to them new objects of desire, and to their depressed tenantry new modes of employment and subsistence, the bond which had hitherto connected the landlord and cultivator became more and more feeble, and it was soon found necessary to establish it upon other foundations than those of feudal protection and dependence, the connection between landlord and tenant came gradually and generally to assume that commercial form, which is at once most conducive to their own interest, and to the general welfare.

3845. *The want of capital ready to be embarked in agricultural pursuits*, was one great obstacle to this change. Under the feudal system there could be little or no accumulation. Property in land was the only means of obtaining the command of labor, and a share of the produce its only recompence. Accordingly upon the breaking up of the feudal system, large tracts were taken into the immediate possession of landholders themselves, because no suitable tenants could be found. The constant superintendence required in cultivating corn lands, as well as the absurd restrictions of those times upon the corn-trade, and the constant demand for British wool on the continent, occasioned these tracts to be laid to grass and pastured with sheep. Hence the grievous complaints, during two centuries, of the decay of husbandry and farm-houses. But this resource of land proprietors was effectual only on soils of an inferior description; on good arable land, the only method by which a part of the produce could reach them in the shape of rent, was to enlarge their farms. The old occupiers were too numerous to spare any considerable part of the produce, and generally too indolent and unskilful to make any great exertions to augment it. In these circumstances, the landholder must either have virtually abandoned his property, or reduced the number of its inhabitants, who were no longer permitted by law to make him that return which had been the original condition of their tenures. But the population of the towns was now gradually increasing, and it was necessary, for the supply of their wants, as much for the benefit of the landholders, that a large disposable produce should be obtained from the soil. The measure of enlarging farms was, therefore, in every view, indispensable. Even such of the tenants themselves, as it was necessary to displace, might have felt but a slight and temporary inconvenience, had the change been gradual. Some of them would have found employment in towns, and others as hired laborers and artisans in the country. The dismissal of the small tenants seems, however, to have been the occasion of much misery; for in the sixteenth century, manufactures and commerce had made comparatively little progress in Britain. In the present times, any length to which the private interest of landholders could operate in this manner, would in a national point of view be too inconsiderable to deserve notice. It is in this way that farms have been enlarged, the most skilful and industrious of these small tenants were naturally preferred, and their possessions afterwards enlarged as their capital increased. The consequence every where has been a better system of cultivation, affording a higher rent to the land proprietor, and a greater supply of land produce for the general consumption.

3846. *The enlargement of farms* can proceed only for a time and to a very limited extent. The interest of the landlord, which gave the first impulse, is ever vigilant to check its progress, when it is attempted to carry the measure beyond due bounds. It is in this that the security of the public consists, if it were ever possible that the public

interest should be endangered by the enlargement of farms. Accordingly, in most of our counties, a few tenants, of superior knowledge and capital, have been seen to hold considerable tracts of land, which, after a few years, were divided into a number of separate farms. The practice of these men is a lesson to their neighbors; and their success never fails to bring forward, at the expiration of their leases, a number of competitors. Whenever skill and capital come to be generally diffused, there can be few instances of very large farms, if a fair competition be permitted. No individual, whatever may be his fortune and abilities, can then pay so high a rent for several farms, each of them of such a size as to give full room for the use of machinery, and other economical arrangements, as can be got from separate tenants. The impossibility of exercising that vigilant superintendence, which is so indispensable in agricultural concerns, cannot long be compensated by any advantages which a great farmer may possess. His operations cannot be brought together to one spot, like those of the manufacturer; the materials on which he works are seldom in the same state for a few days, and his instruments, animated and mechanical, are exposed to a great many accidents, which his judgment and experience must be called forth instantly to repair.

3847. *It has been said, indeed, that a great farmer may pay a higher rent, because he saves the family expenses of a number of small tenants.* But from what fund do these tenants maintain their families? It ought to be either from the profits of their capital, or the wages of their labor, or from both combined, and certainly not from the landlord's just share, in the shape of an abatement of rent. If they cannot pay so high a rent, it must be because their capital and labor are less productive to the public than those of the large farmer. Such men might, in most cases, be employed with more advantage, even to themselves, in some other profession.

3848. *The various other reasons assigned for the great enlargement of farms are equally nugatory.* There is generally no saving to the landlord in buildings and fences; and a very small difference of rent will pay for the trouble of keeping accounts, and settling with twenty tenants instead of one. The fact certainly is, that the principal, if not the only reason why farms have been enlarged, is, the higher rent paid by their occupiers. To pay this rent, they must bring to market more produce, and thus they are enabled to do, by the distribution of their crops and live stock to suitable soils and pastures; by an economical arrangement and regular succession of labor throughout the year; by the use of machinery; and, still more than all, perhaps, by the investment of capital in those permanent improvements, which augment both the quantity and value of their products. Rent, in fact, is an almost unerring measure of the amount of the free produce; and there is no better criterion for determining whether a tract of country be laid out in farms of a proper size, than the amount of the rent paid to its proprietors. Their interest is, in this instance, completely identified with that of the great body of the people.

3849. *If we examine the various sizes of farms in those districts where the most perfect freedom exists, and the best management prevails, we shall find them determined, with few exceptions, by the degree of superintendence which they require.* Hence, pastoral farms are the largest; next, such as are composed both of grazing and tillage lands; then such rich soils as carry cultivated crops every year; and, finally, the farms near large towns, where the grower of corn gradually gives way to the market-gardener, cultivating his little spot by manual labor. The hills of the south of Scotland are distributed into farms of the first class; the counties of Berwick and Roxburgh into those of the second; and the smaller farms of the Lothians and of the Carse of Gowrie, where there seems to be no want of capital for the management of large farms, are a sufficient proof of the general principle which determines the size of farms. (*Sup. Encyc. Brit. art. Agr.*)

#### SECT. II. *Of laying out Farms and Farmeries.*

3850. *The arrangement of farms naturally divides itself into whatever relates to the farmery or home stall, and what relates to the arrangement of the fields, roads, fences, and water-courses.* In a country like Britain, long under cultivation, it is but seldom that these can be brought completely under the control of the improver; but cases occur where this may be done without restraint, as in the enclosure of large commons; and in Ireland and the highlands of Scotland, the opportunities are frequent.

##### SUBSECT. 1. *Of the Situation and Arrangement of the Farmery.*

3851. *The general principles of designing farmeries and cottages having been already treated of: we have in this place chiefly to apply them to particular cases.* Though the majority of farms may be described as of mixed culture, yet there are a number which are almost exclusively devoted to pasture, as mountain farms; to meadow culture, as irrigated or overflow lands; lands in particular situations, as in fenny districts, and those situated on the borders of some description of rivers: — there are others in which peculiar crops are chiefly raised, as in the case of the hop and seed farms of

Kent, Essex, and Surrey. All these require a somewhat different kind and extent of accommodation in the farm buildings.

3852. *The requisites for a farmery common to most characters of farms* are, a central situation, neither too high nor too low, shelter, water, exposure to the south or south-east, in preference to other points; a level or flat area of sufficient extent for the buildings, yards, and gardens; grass-land sufficient for one or more small enclosures; and suitable outlets to the different parts of the farm, and to public roads and markets.

3853. *Some of these requisites may be supplied by art*, as shelter, by plantations; water, by wells and ponds; a flat, by levelling; grass-lands, by culture; and the direction of the roads depends entirely on the designer. But in some cases the situation of the farmery cannot be rendered central, as frequently happens in the fenny districts of Cambridgeshire, where danger might be incurred from extraordinary floods; and in the case of mountainous sheep farms, where a central situation might be so elevated as to be deprived of most of the other requisites. Still, even in these cases, the general requisites ought to be attained as far as practicable, and there are degrees of attainment as to a central situation to be arrived at, even among fens and mountains.

3854. *Excellent examples of different descriptions of farmeries*, are to be found in Berwickshire, Northumberland, East Lothian, and on the Marquess of Stafford's estates in Shropshire, Staffordshire, and Sutherland. Besides a great number of cottages and farmeries of different descriptions, thirty-seven new farmeries have been erected by the Marquess of Stafford, in Shropshire alone. Loch, Lord Stafford's agent, in describing these (*Account of Improvements on the M. of Stafford's Estates, &c.*), states, that "much attention and consideration has been given to the plans of these buildings, with the view of combining as many advantages as possible, and of arranging the different parts in such a way, as to save the time of the tenant and his people, and in order that their extent might be reduced to the least size practicable, securing at the same time the accommodation required. The most approved plans in both ends of the island were consulted, and a gradual improvement has been made on them. The latter ones combine the advantages of the English and Scotch buildings, avoiding, it is hoped, their respective defects. To almost every one of these homesteads is attached a threshing machine, constructed on the best principles; wherever water could be obtained, that has been made use of as the impelling power; and of late, some of the more extensive farms have been provided with steam-engines for that purpose."

3855. *In selecting a few of these examples*, the first we shall mention is that of Sidera or Cider Hall, in Sutherland, erected in 1818. The soil of this farm is of a light and excellent quality, particularly suited to the Norfolk rotation of husbandry, which is followed by Rule, the new tenant, a native of the county of Roxburgh. The house and homestead cost 2200*l.* It is built in the most sufficient manner, of stone and lime, and covered with Easdale slate, from the west coast of Scotland. In the garden, which is an old one, there are several apple, pear, and gean, or small black cherry trees, of so considerable a size, with some of the finest holly trees to be met with any where, as to show that there is nothing in the climate to prevent the growth of even the more delicate kinds of timber, if not exposed to the sea breeze.

3856. *The accommodations of the house* are, on the ground floor, a parlor, lobby, and staircase, family room, pantry, kitchen, open yard, and flower-garden; of the chamber story, a bed-room and bed-closet, two bed-rooms, maid-servant's room, and bed-room. The offices contain a cart-house, stable, tool-house, threshing-mill, and straw-house, horse-course, cattle-sheds, dairy, calf-pen, cow-byre, feeding-byre, boothy (*i. e.* booth or lodge) for ploughman; pigstyes, and poultry above; paved way, and cattle-yards.

3857. As an example of a *Northumberland farmery* for a farm of from 400 to 500 acres, we have recourse to *The Gen. Rep. of Scotland*. The accommodations are as follow: in the dwelling-house are the entrance, stairs to chambers, and cellars, and lobby, dining-room, pantry, coal-closet, parlor, business-room, kitchen, back kitchen, dairy, store-room, poultry, farm servants' kitchen, boiling-house, root-house, riding-horse stable. In the economical buildings are a cart-shed, straw-barn, and granary over; corn-barn, hinds, byre for three cows, byre for ten cows, with feeding passage in the centre; calf-house, loose horse place, stable, feeding sheds for cattle, with feeding passage along the centre; pigs, dung-places, straw-yards, cart-shed, and open court. The aspect of the house is south, and the garden and orchard are in front of it.

3858. As an example of a very complete *farmery for a turnip and barley soil*, we give that of Fearn (*fig. 465.*), erected by the Marquess of Stafford in the parish of Escall Magna, in Shropshire, in 1820. The farm contains 460 acres of turnip soil; and the farmery the following accommodations, including a threshing machine, driven by steam. In the house are two parlors (*a, a*), family-room (*b*), brew-house, two stories (*c*), pantry (*d*), milk-house (*e*), kitchen (*f*), bed-rooms (*g*), men servant's bed-room (*h*). In the court offices a hackney-stable (*i*), stair under-cover (*k*), waggon-shed, and granary over (*l*), tool-house (*m*), cow-house (*n*), places for turnips and straw (*o, p*), steam-engine (*q*),



barn (*r*), straw or other cattle-food (*s*), stall-fed cattle (*t*), stables (*u*), turnip-houses (*v*), piggeries, poultry, tools, and necessary (*w*), cattle-sheds to each yard (*x*).

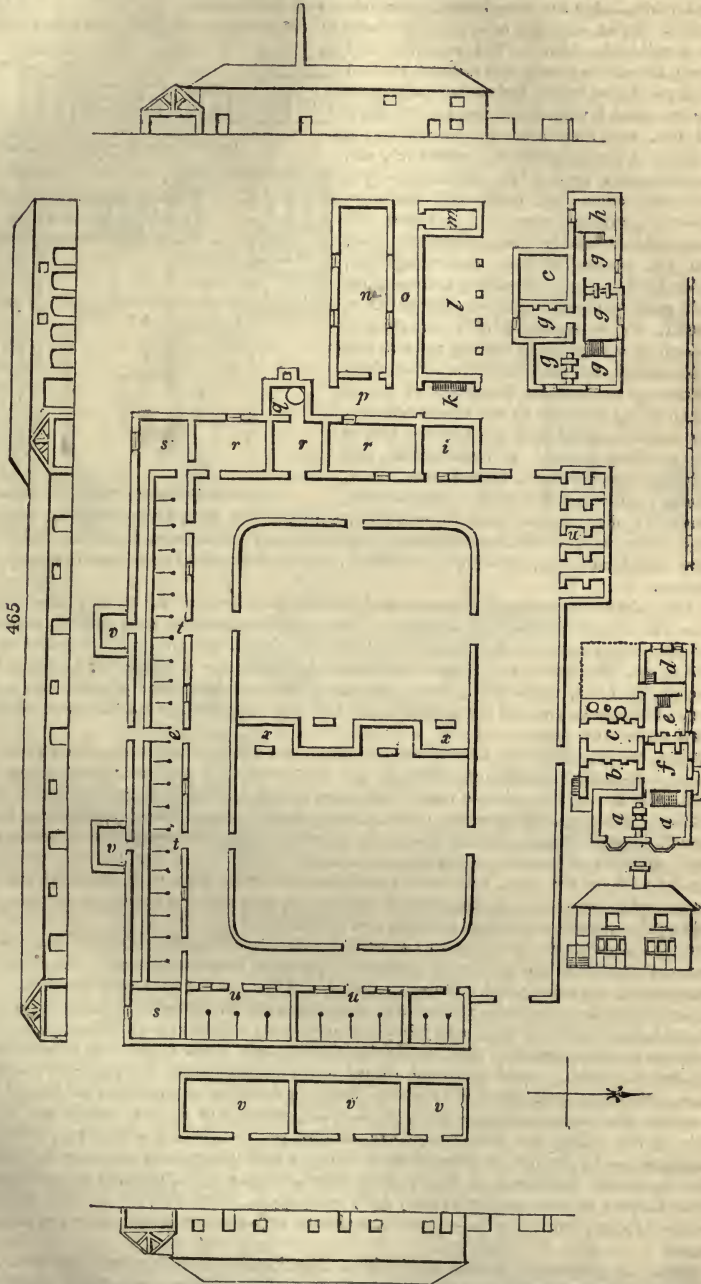

3859. As an example of a farmery to be managed by a bailiff, we give that of Skelbo, also in Sutherland. The farm consists of 450 acres, the greater part taken from a heathery waste. It contains a suitable house for the grievie or bailiff, and attached to the offices are a threshing machine, combining a corn or meal-mill. Its accommoda-

tions are a chaff-house, corn-rooms, threshing-mill, with water-wheel and straw-house; cattle-sheds, poultry-houses, and piggery; stables, byres, cart-shed, cattle-shed, dairy, meal-house, lodge for ploughmen, paved way, and cattle-yards.

3860. As an example of a *small farmery in the county of Stafford*, we select that of

Knollwall. (*fig. 466.*) The extent is 104 acres; the soil is strong and rather wet, and there are some water and other meadows. The house and yard-buildings are of brick and tile, and their accommodations are, a kitchen (*a*), brew-house (*b*), parlor (*c*), sitting-room (*d*), pantry (*e*), milk-house (*f*), court-yard open (*g*), coals (*h*), hackney-stable (*i*), turkey-house (*k*), pigstyes (*l*), waggon-horse stable (*m*), corn-bay (*n*), barn (*o*), straw bay (*p*), cow-tyings (*q*), fodder-bins (*r*), calf-houses (*s*), and waggon-shed, granary over, connected with barn. (*t*)

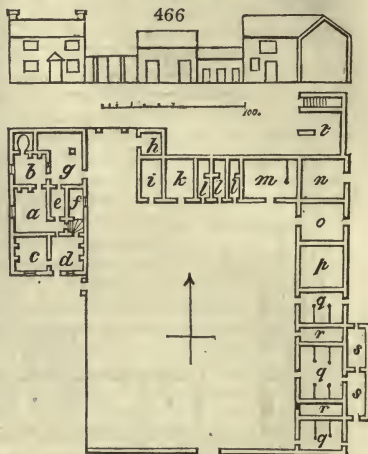

3861. As an example of a *middle-sized farmery on a clayey soil*, we may refer to that of Newstead, in Staffordshire. This farm contains 314 acres, and the tenant, Ford, is said to be an example to the whole country. The accommodations of the farmery are, in the dwelling-house, a house-place and kitchen, master's-room, brew-house, dairy, pantry, parlor, bed-rooms, cheese-room, attics. In the court a shed for waggons, with granary over, hackney stable, waggon-horse stable, cattle-sheds, turnip-houses, fodder-house, straw-bays, threshing-mill, with water-wheel, corn-bay, tool-house, workshop, bay for unthreshed corn, small granary, and pigstyes.

3862. As an example of an *economical farmery for a farm of 50 or 60 acres*, we copy from *The General Report of Scotland*. The accommodations are; in the house, a kitchen, parlor, store-room, pantry, with three bed-rooms, and a light closet over; closet, milk-room, and scullery. In the economical buildings are a stable, with a loose stall, byre for ten cows, cattle-shed, barn, cart-shed, with granary over; pigstyes and cattle-yard. This appears one of the most compact and eligible plans for the farmeries of arable farms under 100 acres.

3863. As an improved *Berwickshire farmery*, we submit another specimen from *The General Report*. Its accommodations are calculated for a farm of 600 acres, and consist, in the dwelling-house range, of a porch, lobby, dining-room, parlor, kitchen, scullery, coal-place, store-room, dairy, pantry, business-room, poultry, steaming-house, bailiff's-room. The economical buildings contain a riding-horse stable, tool-house, cart-shed, with granary over; corn-barn, straw-barn, feeding-house for 36 head of cattle, root-house, byre for cows, calf-pens, stable for ten horses, pigs, with yard and troughs, cattle-sheds, dung-basin, and urinarium under; cattle-yards, cart-road paved, rick-yard, mill track, open court, lawn, garden, and orchard.

3864. *A farmery for a turnip soil of from 600 to 900 acres*, from the same work, deserves consideration as a very complete specimen of arrangement. Omitting the farm-house, the economical buildings contain a stable, cow-house, servants' cow, root-house, young horses stable, straw-barn, corn-barn, stable, cart-shed, place for pickling, wheat, killing sheep, or other odd jobs; feeding-house, carpenter's workshop, pigs, geese, common poultry, turkeys, pigs, cattle-sheds, dung and straw court with urinariums in the centre of each, paved cart-road round, open court between the yard and dwelling-house-rick-yard, paddocks of old pasture, ponds for drinking and washing the horses' legs.

3865. *The accommodations for a farm-house*, suitable to such a design and to the style of life which the person who can occupy such a farm is entitled to enjoy, are as follow:— In the parlor story there is a lobby with staircase to chambers and cellars, drawing-room, bed-room, a family work-room, dining-room, business-room, kitchen, barrack-room or man-servant's room, &c.; store-room, dairy, and on the first-floor two best bed-rooms, two other bed-rooms, bed-closets, and another closet; over are servants' rooms.

3866. *As a farmery for an arable farm near London of 350 acres (fig. 467.)*, we shall give as an example one erected (with some variations) in the county of Middlesex, in 1810. It is to be observed, that in Middlesex farming, a great object is hay, especially meadow hay for the London market, which gives rise to the covered spaces for loaded carts (*x*); it being the custom to load the carts at night, place them under cover, and yoke and go on the road early the following morning. The accommodations of this farmery

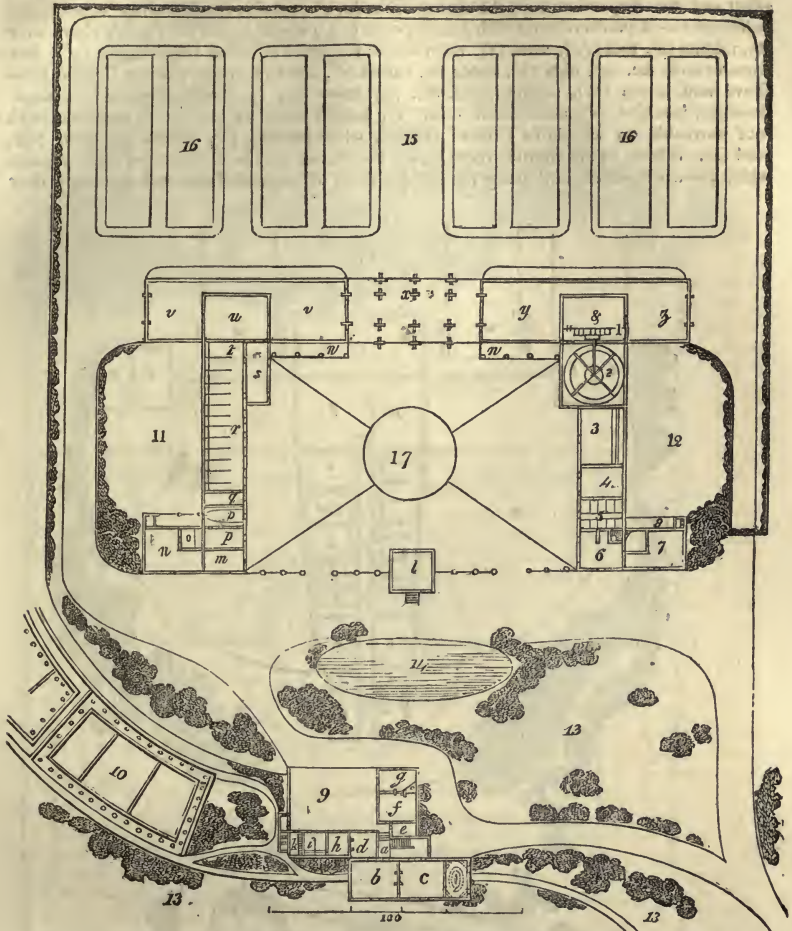

are, in the dwelling-house, a lobby and stair (*a*), dining-room (*b*), drawing-room and green-house (*c*), a housekeeper's room, nursery or butler's pantry (*d*), dairy (*e*), kitchen (*f*), back kitchen and brew-house (*g*), gig-house or coach-house (*h*), small stable (*i*), harness-room and stair to mens' room and hay-loft (*k*). In the economical buildings are a granary (*l*), pigs (*m*), carts or odd articles (*n*), water-closet (*o*), poultry (*p*), litter for the stable (*q*), stable for twelve horses (*r*), chaff-room (*s*), litter (*t*), room for cutting hay into chaff (*u*), places for horse food, or straw, hay, &c. (*v*), cattle sheds (*w*), open colonade for loaded hay-carts (*x*), straw end of barn (*y*), corn-floor (*z*), unthreshed corn and corn-floor (*3*), machine (1), mill course (2), cows (3), cow-food (4), calves (5), bailiff's house (6), implements (7), wood-house, coals, &c. (8), kitchen-courtyard to master's house (9), garden (10), poultry-yard (11), bailiff's garden (12), lawn, shrubbery, and sheep-walk (13), pond (14), rickyard (15), stack-stands (16), urinarium (17).

3867. In the elevations of this farmery (*fig.* 468.), some attention has been paid to effect, by intermingling trees, chiefly oaks, thorns, and honeysuckles.



3868. *An anomalous design of a farmery for a hay-farm (fig. 469.), calculated for effect and for inspection from the sitting-room (a, a) contains the following economical buildings:— A poultry-house with granary over (a), a chaise-house with men's room over (b), rabbits (c), tools (d), carts (e), open sheds for carts or other implements (f), sick horse or cow, &c. (g), pigs (h), stable (i), calves (k), cows (l), open passage lighted from above and pump (m), saddle-horse, &c. (n), straw (o), chaff-cutting room (p), hand-threshing-machine (q), unthreshed corn (r), loaded carts of hay (s, t), hay-ricks with roof moveable on wheels to protect the hay while binding (u), ponds (v), lawn (w), yard (x). Sitting in the circular room (a, a), the master may look down the light passage which has a wire door, and along the oblique front of the buildings, and see every door*

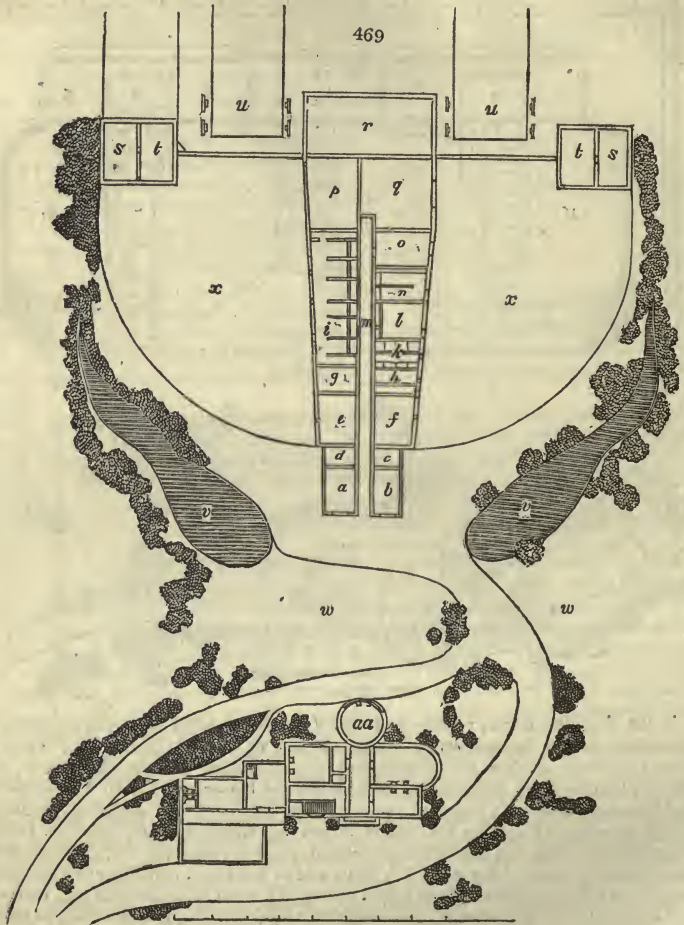

that is opened. He may also, as appears by the elevation (fig. 470.) see the men binding hay under the moveable covers.



471

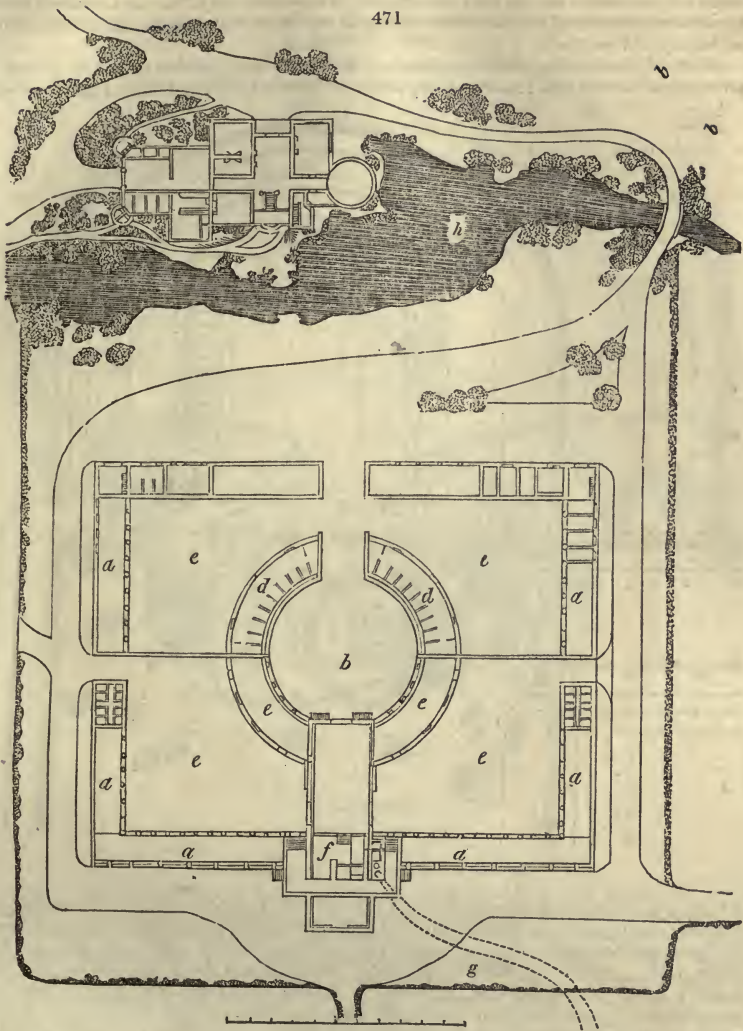

3869. *An anomalous design for a corn and stall-feeding-farm (fig. 471.), in which the stacks are built on the tops of the stables, cattle, and cart-sheds (a), may be noticed as pleasing in effect; but not likely to be so useful as the more simple plans. The hay, roots, and straw, are stacked in the central circle (b), and very readily supplied to the stable (c), cow-stalls (d), or feeding yards (e). The threshing-machine (f), is driven by water which is supplied by a circuitous route (g), from the pond near the house (h). The elevation (fig. 472.), has a good effect*

472

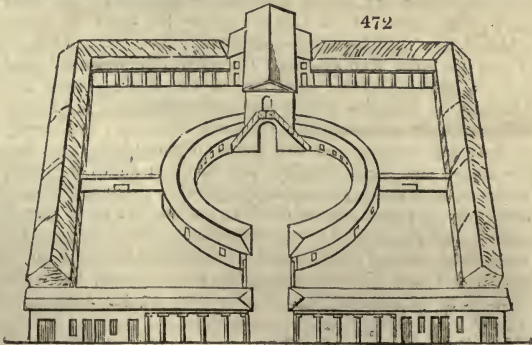

when all the stacks are in their places, and untouched; but as they are removed to the barn the appearance of the flat-roofed sheds will not be so consonant to established notions of beauty and neatness.

3870. *A farmery for a meadow-farm of 250 acres near London (fig. 473.), may be arranged as follows:—* The house may contain a porch, lobby, and stair to chambers and

473

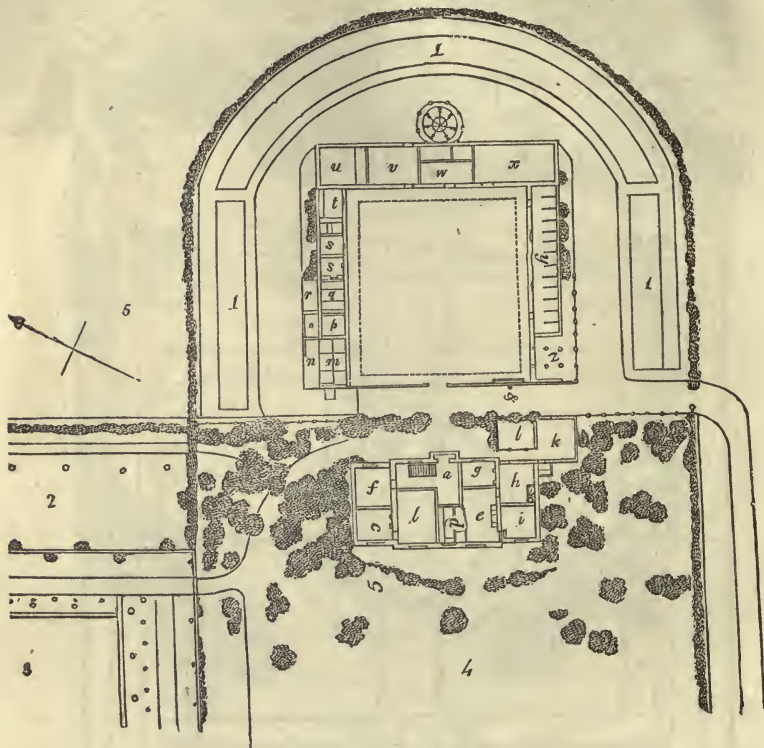

cellars (*a*), parlor (*b*), bed-room or study (*c*), pantry (*d*), kitchen (*e*), lumber-room (*f*), business-room (*g*), back kitchen (*h*), coal cellar, and maid's room over (*i*), wood-house (*k*), yard and pump (*l*), pigs (*m*), chaise (*n*), poultry (*o*), tools and roots, &c. (*p*), two stalls, and a saddle and harness place (*q*), harrows and large implements, &c. (*r*), bailiff's house or men's lodge (*s*), cows (*t*), chaff-cutting room, and granary over (*u*), straw-barn (*v*), corn-floor (*w*), unthreshed corn (*x*), stable and stall for litter (*y*), loaded or empty carts and implements (*z*), watering-trough (*z*), rick-stands (*1*), bailiff's garden (*2*), master's garden (*3*), lawn (*4*), paddock of old grass (*5*).

3871. *An anomalous design for a turnip-farm of 500 acres (fig. 474.), contains a dwelling-house (a), on an eminence commanding not only the farmery (b), but great part of the farm. It is surrounded by the ricks for shelter (c), and by a pond (d), which drives the threshing-machine (e), and forms a foreground to the distant scenery. There is a large feeding-shed (f), a bailiff's house and garden (g), and the other usual accommodations. The elevation of the feeding-sheds and end of the barn looking towards the house is simple and not inelegant. (fig. 116.)* Farmeries of this sort are not submitted as examples for general imitation; but merely as sources of ideas to such as have the designing of this species of rural buildings, for employers who have a taste for design and for originality, and who can afford to gratify that taste. It is a poor business, and one which never can procure much applause, when a proprietor of wealth and cultivated mind, erects for his own use the same sort of farmery, or, indeed, any other buildings, as the tenants who support him. In East Lothian, Berwickshire, Northumberland, and on the Marquess of Stafford's estates both in England and Scotland, are some noble examples of substantial, commodious, and even elegant farmeries. (See *Gen. Rep. of Scotland, and Loch's Imp. on the Marq. of Stafford's Estates, &c.* 8vo. 1819.)

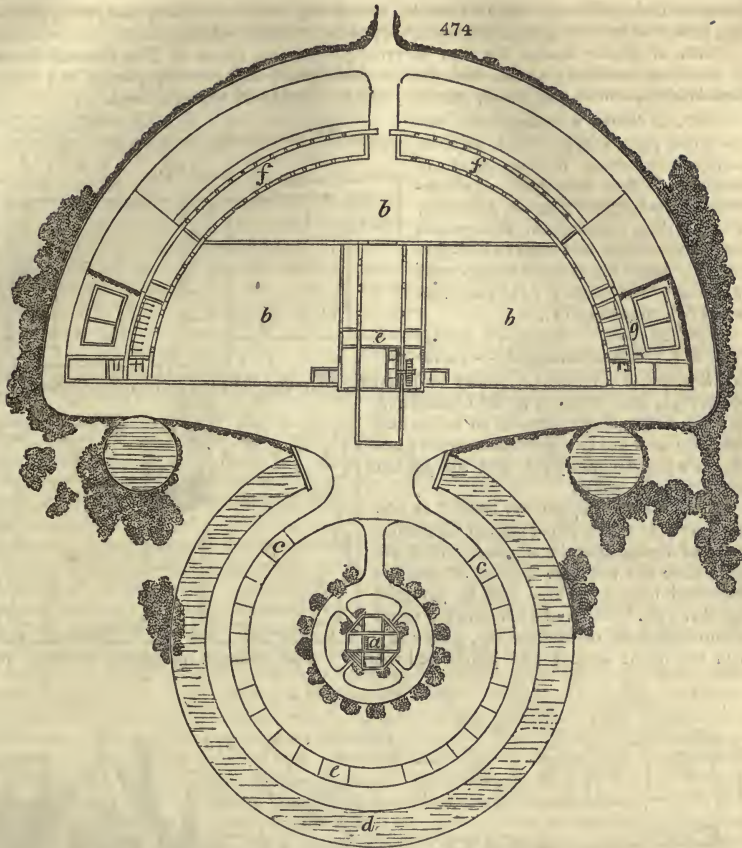

SUBJECT. 2. *Of laying out Cottages.*

3872. Cottage buildings include a variety of habitations from the farm-house downwards. On a large estate there will be cottages for tradesmen and mechanics, with and without fields and gardens; others for market-gardeners and nurserymen, surrounded by gardens and orchards; for operative manufacturers; for day laborers; and on the farm lands near the farmeries, for ploughmen and herdsmen. The extent of ground which ought to accompany these cottages must be determined entirely by the demand; the regular laborer and ploughman require the least; and the gardener and tradesman, who keep a horse or horses, and cow, the most.

475

3873. A cottage fit for a tradesman, mechanic, or bailiff, given in *The General Report of Scotland*, contains the following accommodations: a porch, lobby, living room, two closets with beds, pantry and dairy, fuel and lumber-place, pig, and garden. The cow is kept at the farmery, if for a bailiff; the poultry over the fuel place, and the bees on stands in the open garden.

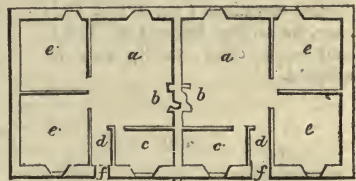

3874. A double cottage of only one floor (fig. 475.) contains in each, the kitchen (a), with oven (b), pantry and dairy (c), lobby, (d), two bed-rooms (e, e), entrance door (f), front court-yard (g), pigs (h), necessaries (i). The gardens are at each end, and the cows supposed to be kept at the farmery.

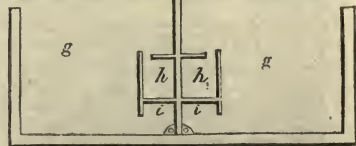

3875. A cottage on a smaller scale contains the entrance and stair, parlor, bed-room with two good bed-rooms over. Behind

5 10 20 30 feet

the main body of the house is a leantoo, containing the kitchen dairy and pantry, brewing, fuel, and lumber place. The usual appendages are detached.

3876. *A double cottage for two married ploughmen*, given in *The General Report of Scotland*, contains a porch, and stair to bed-rooms, living-room, pantry and dairy, back kitchen, cow or pig-house, gardens, and two good bed-rooms to each.

3877. *A laborer's cottage, with cow-house and piggery* (fig. 476.), as commonly constructed in the south of Scotland, is thus arranged:—the cow-house (a) and piggery (c) are in a leantoo. The dwelling contains, on the ground floor, an entrance and stair to bed-garrets (b), large kitchen and living-room (e), dairy and pantry (d), coal and wood (g), necessary (h).

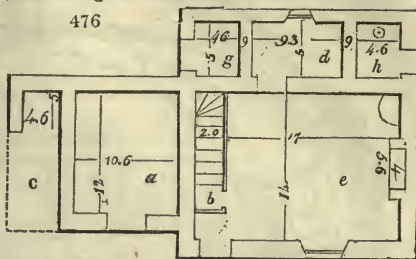

3878. *A good tradesman's cottage* (fig. 477.) is thus arranged:—parlor (a), kitchen (b), closet (c), dairy and pantry (d), closet to parlor (e), tool-house (f), and fuel place (h), back entrance to house and stair (i); over are two good bed-rooms; behind is a small court-yard, and the garden surrounds the whole.

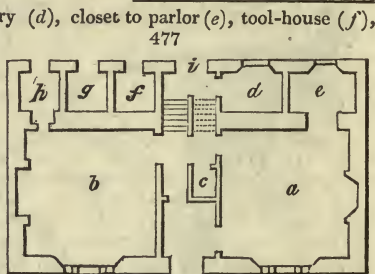

3879. Where cottages are erected as picturesque objects, various external forms and styles of design may be adopted, and at the same time the requisite degree of comfort preserved within. Three may be grouped together (fig. 478.) and each have the usual accommodations of kitchen (a), parlor (b), with the usual closets and garret bed-rooms.

For cottages of upper servants, on

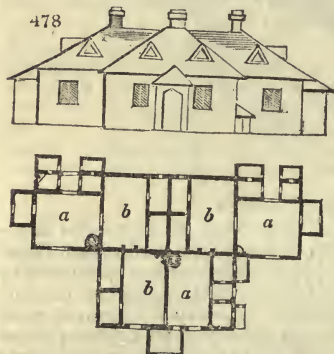

the demesne lands of proprietors, Gothic elevations (fig. 479.), Chinese, Swiss, and Italian (fig. 480.), and every other variety may be adopted.

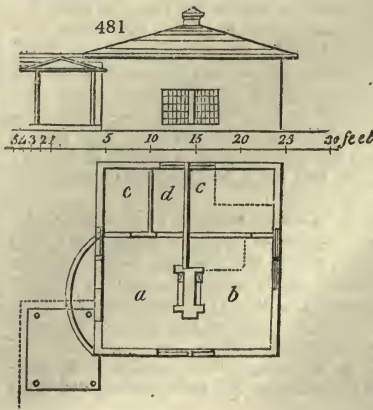



3880. For entrance lodges there are many elegant designs by Gandy, Robertson, Papworth, and others: some simple and modern, and others in imitation of the elder styles of building.

3881. A very simple entrance lodge of one story (fig. 481.) may contain a kitchen (a), parlor and bed-room opening into it (b), pantry (c), and closet (d). Towards the road there may either be a bow projection or porch. Detached, in the garden and concealed by trees and shrubs, may be the usual appendages to comfortable cottages.

SUBJECT. 3. *Of laying out the Farm Lands.*

3882. In arranging farm lands the principal consideration is the size and shape of the fields, and the next access to them and to the farmery by proper roads.

3883. With respect to roads, sometimes a farm is situated on both sides of a highway; in which case all the fields may be made to open into it, either directly or through an intervening field. Here no private road is wanting, excepting a few yards to reach the farmery. But when, as is most generally the case, the lands are situated at a distance from a great road, and approached by a lane or bye-road, then from that bye-road a private road is required to the farmery, and a lane or lanes from it so contrived as to touch at most of the fields of the farm. In wet and clayey soils, these lanes must be formed of durable materials; but in dry soils, provided attention be paid to fill in the cart ruts as they are formed (by the leading out of dung, or home of corn,) by small stones, gravel, or even earth, the lane may remain green; and being fed with sheep or cattle will not be altogether lost. It is essentially necessary to make a piece of road at the gate of every enclosure, being the spot which is most frequently in use. Without this precaution, it often becomes a mire where corn is thrown down and spoiled in harvest, or if it is attempted to avoid the mire, the gate-posts and neighboring fence are often damaged. (*Communications to the Board of Agriculture*, vol. ii. p. 251.)

3884. With good private roads a farmer will perform his operations at much less expense, the labor of the horses will be much easier; a greater quantity or weight of grain and other articles may be more expeditiously carried over them; manure can be more easily conveyed to the fields; the harvest can be carried on more rapidly; and wear and tear of every description will be greatly reduced. (*Code of Agriculture*, p. 158.)

3885. The form and size of fields have too often been determined without much regard to the size of the farm, the exposure and the equability of the soil. This is the more to be regretted in the case of live fences, which ought to endure for a long course of years, and which cannot be eradicated without considerable expense. In *The Code of Agriculture* it is observed, that "when a whole farm is divided into fields of various sizes, it is difficult to form a plan, so as to suit a regular rotation of crops, or to keep very accurate accounts. Whereas, by having the fields in general of a large size, the whole strength of a farm, and the whole attention of the farmer is directed to one point; while an emulation is excited among the ploughmen, when they are thus placed in circumstances which admit their work to be compared. Some small fields are certainly convenient on any farm, for grazing and other purposes, to be afterwards explained. On elevated situations also, the shelter derived from small enclosures is of use.

3886. A number of small enclosures, irregularly shaped, surrounded with trees or high hedges in corn farms, and more especially in corn lands situated in a flat country, where shelter is unnecessary, is exceedingly injurious to the farmer. Besides the original expense of making the enclosures, the injury done to the crops of grain, produced by the want of a free circulation of air, and the harbor afforded to numbers of small birds; the very site of numerous hedges, with their attendant ditches, and the uncultivated slips of land on both sides of them, consume a much larger proportion of arable land than is commonly imagined. Hedges, especially if accompanied by rows of trees, greatly exhaust the ground of its fertility, nourish weeds, the seeds of which may be widely disseminated, and, by the exclusion of air, the harvesting of the crop is carried on more slowly. Even upon meadow land, small enclosures, encircled by hedges, are injurious, as they prevent the circulation of air for making or drying the hay. Small enclosures, with high hedges and trees, are also extremely injurious to the roads, in their neighborhood.

3887. With fields of a considerable size less ground is wasted, and fewer fences are to uphold. The crops of grain, being more exposed to wind, can be harvested earlier, and it suffers less from damp seasons. Small enclosures in pasture are more productive in winter, being better sheltered; but in summer the larger and more open the enclosures are the better; for in hot weather both cattle and sheep always resort to the most airy places. It is easier also, when they are in pasture, to obtain a supply of water in large fields than in small ones: indeed fields are sometimes so small, that it is very difficult to procure an adequate supply of water, even in winter. But the conclusive argument in favor of large arable fields is this, that where fields are small, much time and labor are wasted by short turnings; and it is now ascertained, "that if fields are of a regular shape, and the ridges of a proper length, five ploughs may do as much work as six

ploughs in fields of a small size, and of an irregular shape; while every other branch of labor (such as dunging, sowing, harrowing, reaping, and carrying in the harvest), can be executed, though not altogether, yet nearly in the same proportion." (*Husb. of Scot.* vol. i. p. 41. and *Sup. Encyc. Brit.* art. *Agr.*)

3888. *The circumstances on which the size of fields ought to depend* are, the extent of the farm in which they are situated, the nature of the soil and subsoil, the rotations adopted, the number of ploughs on the farm, the inclination of the ground, its being in pasturage or otherwise, and the nature of the climate. (*Code.*)

3889. *Extent of the farm.* The size of fields ought certainly, in some measure, to depend upon the extent of the possession. In small farms near towns, from six to twelve acres may be sufficient; but where farms are of a considerable extent, fields from twenty to even fifty acres, and, in some particular cases, as high as sixty, may be used to advantage. In general, however, even on large farms, when permitted by local circumstances, fields of a medium size, as from fifteen to twenty-five English acres, are recommended by competent judges.

3890. *Soil and subsoil.* In dividing a farm into fields, the nature of the soil and subsoil ought to be kept in view. Where the soil is various, it would be proper to separate the light from the heavy. They are not only better calculated for different crops and different rotations, but are naturally adapted to be cultivated at different seasons. It is unfortunate, therefore, to have soils of a heterogeneous nature mingled in the same field. But where this partially takes place, for instance, where there are only one or two acres of light soil, to ten or twenty of strong soil, let the following plan be adopted:—At any slack time, either in summer or winter, more especially when the field is under fallow, employ two carts and horses with four fillers, to cover the acre or two of light soil, with the strong soil contiguous, and the soil in the field will then become more uniform. In fields where light soils predominate, the plan might be reversed. This plan, though at first expensive, is attended with such advantages, that whenever it is necessary and practicable, it ought to be carried into effect.

3891. *The rotation adopted.* It may be considered as a good general rule, to divide a farm according to the course of crops pursued in it; that is to say, a farm with a rotation of six crops should have six fields, or twelve, according to circumstances. It is proper to have a whole field, if the soil be uniform, under one crop; and every farmer of experience knows the comfort of having the produce of the farm as equal every year as the soil and season will admit of.

3892. *Number of ploughs.* It is likewise proper that the size of fields should be somewhat in proportion to the number of horses and ploughs on the farm. For instance, where six two-horse ploughs are kept, and where it is difficult, from the nature of the soil, to have the fields of a larger extent, sufficiently dry, from eighteen to twenty-five English acres are considered to be a convenient size. With twelve horses, a field of that extent can always be finished in four, or at the utmost in five days; there is less risk, therefore, of being overtaken by bad weather, and prevented from completing the preparation of the land for the intended crop. When the fields are of too great an extent, in proportion to the stock kept, a considerable interval must occur between the sowing of the first and of the last part; and it will in general be desirable to have each field cleared at the same time in harvest. The harrowing also is done more economically, when the field is sown at once, than in several portions; and where rolling is required, that operation being most effectually done across, it cannot well be accomplished till the field has been completed. Hence the advantages of having the size of the fields in some degree commensurate to the stock of working animals upon the farm.

3893. *Inclination of the ground.* It is, however, evident that the size of the fields must in some respects depend on the flatness, or the hilly shape of the ground. Even on dry land, if there be a rise on the ground, from fifteen to twenty chains is sufficient length; for if the ridge be longer, the horses become much fatigued if compelled to plough a strong furrow up hill beyond that length in one direction. This objection, however, to large fields, may in some measure be obviated, by giving the ridges and furrows in such fields as are on the sides of a hill, such an obliquity as may diminish the difficulties of the ascent.

3894. *Pasturage.* Where the system of grazing and tillage is alternately followed (more especially where the fields are pastured for two or three years in succession), it is convenient to have the fields of from twenty to perhaps thirty English acres. The farmer is thus enabled to divide his stock, which he cannot well do with larger fields. The cattle or sheep remain more quiet than if a greater number were collected together, and less grass is destroyed by treading. When such a field has been pastured for some time, the stock should be removed to another, till the grass in the former has renewed, and is fit for being eaten. Such a size also, in general, suits graziers better than larger ones, and consequently fields of this extent, when in pasture, generally let for more rent.

3895. *Climate.* The last circumstance to be considered in determining the proper size of fields, is the nature of the climate. In dry and cold climates, small enclosures are desirable on account of shelter; whereas, in wet countries the fields under culture cannot be too open and airy for the purpose of drying the ground, of bringing forward and ripening the grain, and of enabling the farmer more easily to secure it during an unfavorable harvest, by having a free circulation of air. But though on large farms, fields should in general be formed on an extensive scale, yet there is a convenience in having a few smaller fields near the farm-house for keeping the family cows; for turning out young horses, mares, and foals; for raising a great variety of vegetables; and for trying experiments on a small scale, which may afterwards be extended, if they shall be found to answer. Where enclosures are too large for particular purposes, and where no small fields, as above recommended, have been prepared, large fields may be subdivided by sheep-hurdles, a sort of portable fence well known to every turnip-grower. In this way, great advantage may be derived from the constant use of land that would otherwise have been occupied by stationary fences; and the expense of subdivisions, which, on a large farm, would necessarily have been numerous, is thereby avoided. This fence is perfectly effectual against sheep, though it is not so well calculated for stronger animals. On dry soils, where sheep are generally pastured, it is not unlikely that by using moveable hurdles, the expense of permanent fences might in a great measure be saved.

3896. *The shape of fields* may be either square or oblong.

3897. *Square fields.* The advantage of having the fences in straight lines, and the fields, when large, of a square form, is unquestionable, as the ploughing of them, under this arrangement, can be carried on with much greater dispatch. Some farmers, whose fields are of a waving or uneven shape, and who enclose with hedge and ditch, carry their fence through the hollows, or best soil, with a view of raising a good hedge, thus often sacrificing, for the sake of the fence, the form of their field. A straight line, however, is preferable, even though it should be necessary to take some particular pains to enrich the soil for the hedge, where it is thin and poor, on any elevation. By means of the square form, an opportunity is afforded of ploughing in every direction, when necessary; and less time is lost, in carrying on all the operations of husbandry in a field of that form than of any other shape. When the waving form is necessary to secure proper water-runs, plantations may be so disposed as to reduce the fields to squares or oblongs, and the fences to straight lines. Rectangular fields have another advantage, that in fields of that shape it may be known, whether the ploughmen have performed their duty, the quantity of work done being easily calculated, from the length and breadth of a certain number of ridges.

3898. *Oblong fields.* When fields are small, an oblong shape should be preferred, that the ploughings may be dispatched with as few turnings as possible. This form has also other advantages. The fields are more easily subdivided, and water can in almost every case be got, by making proper ponds in the meeting or joining of three or four fields, whose gutters or ditches will convey water to the ponds. In turnip soils, where the shape is oblong, it is easier to divide the turnips with nets or hurdles, for the convenience of feeding them off with sheep. If the ridges are too long, and the field dry and level, the length may be reduced by making cross head-lands, or head-ridges, at any place that may be considered the fittest by the occupier. (*Code of Agr.* 152 to 157.)

3899. *Hedge-row trees* are very generally objected to by agriculturists. Notwithstanding the garden-like appearance which they give to the landscape, "it seems to be agreed by the most intelligent agriculturists that they are extremely hurtful to the fence, and for some distance to the crops on each side; and it is evident, that in many instances the highways on the sides of which they often stand, suffer greatly from their shade. It has therefore been doubted, whether such trees be profitable to the proprietor, or beneficial to the public; to the farmer they are almost in every case injurious, to a degree beyond what is commonly imagined. (*Supp. to Encyc. Brit.* art. *Agr.*)

3900. *The opinion of Loch*, a well informed and unprejudiced improver of landed property, is of an opposite description. He says, there is no change in the rural economy of England more to be regretted, than the neglect which is now shown to the cultivation and growth of hedge-row timber. The injury which it does to the cultivation of the land is much exaggerated, especially if a proper selection of trees is made; but even the growth of the ash, so formidable to agriculturists, might be defended on the ground, that without it the best implements employed in the cultivation of the soil could not be made. It is well known that good hedge-row timber is by far the most valuable both for naval and domestic purposes. Its superior toughness rendering it equally valuable to the ship and to the plough-wright. The value which it is of in affording shelter, is also of material use; besides, the raising of grain is not the only purpose of life, or the only matter to be attended to, nor the only object worthy of attention. The purposes of war and of national glory, the protection and the extension of our commerce, the construction and repair of buildings, and even the enjoyment arising from the rich and beautiful effect produced by such decoration and ornament, are all objects of material importance to the well-being and constitution of a highly cultivated state of society. Even upon the more narrow basis of individual utility, this practice might be defended and recommended; for it is not useless to consider how many families and estates have been preserved, when pressed by temporary difficulties (from which none are exempted), from a fall of hedge-row timber. One of the best legacies which a great proprietor can leave his country and his family, is an estate well stocked with such trees.

3901. *The gates of fields* should in most cases be placed in the middle of that side of the field which is nearest the road; and not in an angle, or at one corner, unless particular circumstances point out this as the preferable mode.

3902. *The drainage and water-courses*, if any, on farm lands, require to be attended to in laying out the fences, so as if possible to make the ditches of the latter serve as open drains; also, when opportunity offers, for conveying streams to be used in irrigation, or for driving machinery. The fences and roads will, to a certain extent, be guided by the course of such stream or streams.

3903. *As an example of laying out farm lands from a newly-enclosed common*, we submit the case of a flat

482

surface, a strong retentive clay soil, a moist climate, a situation distant from markets, with no other object in view than that of making as much of the lands as possible. A public road (*fig. 482 a*) passes the farm, and the farmery is approached by a private road (*b*). The size of the farm deemed proper is 350 acres; the most profitable mode of occupation is, 180 in arable, and the remainder in pasture. The arable subjected to a rotation of, 1st, beans, drilled, or naked fallow, dunged; 2d, wheat; 3d, clover and rye-grass, fed off or mown for soiling cattle; 4th, wheat or oats, if the clover was mown, dunged. The grass-lands are supposed to be wholly fed off chiefly with cattle; but also with ten cows, for butter and breeding, and a few sheep.

3904. *The buildings (e)* are placed in the centre

of the farm, and contain stabling for four work-horses, and open sheds for eight oxen; 130 feet of sheds for thirty fattening cattle; a barn, with threshing-machine impelled by wind; houses for ten cows, and other conveniences in proportion. There is a kitchen-garden, orchard, rick-yard, and two paddocks (*d, f*), adjoining the farmery.

3905. *The grass-fields (g)*, contain only ten acres each, to admit of the great advantage of shifting the stock from one to another. They are most distant from the farmery, because requiring least cartage; and some of them being in the lowest part of the farm, they may be irrigated. Trees are avoided in the fences, as injurious in flat surfaces and adhesive soils.

3906. *The arable lands (h)*, are preserved in the centre, to save carting to and from the farmery; and the enclosures are four times the size of the grass-fields, each shift forming one large enclosure, containing four fields, divided only by open ditches for carrying off the surface water. The two small central fields shown under aration, are supposed alternately in turnips, potatoes, cabbages, &c. for cows, &c. and wheat. The paddocks and closes are for calves or colts.

3907. The chief, and almost sole *products of this farm* will be wheat and beef; the former best worth sending to a distant market; the latter easily transported to any distance; and both staple commodities.

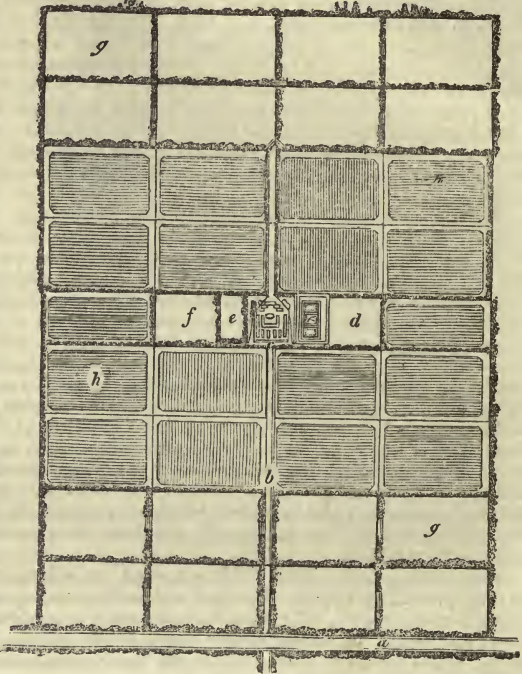

## BOOK III.

## OF IMPROVING THE CULTURABLE LANDS OF AN ESTATE.

3908. HAVING completed the general arrangement of an estate, the next thing is to improve the condition of that part of it destined to be let out to tenants, and from which, as already observed, the chief source of income is derived. The farm lands being enclosed and subdivided, and the farmeries and cottages built in their proper situations, in many cases no other improvements are wanted on the soil than such as are given by the tenant in the ordinary course of culture. But there are also numerous cases, in which improvements are required which could not be expected from an occupier having only a temporary interest in his possession; and these form the present subject of discussion. Such improvements are designated by agriculturists *permanent*, as conferring an increased purchasable value on the property, in opposition to improvements by a temporary occupier, the benefits of which are intended to be reaped during his lease. The latter class of improvements include fallows, liming, marling, manuring, improved rotations; and others of greater expense, according to the length of lease, rent, and encouragement given by the landlord; the former, and which we are now about to discuss, include draining, embanking, irrigating, bringing waste lands into cultivation, and improving the condition of lands already in a state of culture.

## CHAP. I.

*Of Draining Watery Lands.*

3909. *Draining* is one of those means of improvement, respecting the utility of which agriculturists are unanimous in opinion. Though practised by the Romans (143.), and in all probability in some cases by the religious fraternities of the dark ages, it was not till after the middle of the last century that its importance began to be fully understood in Britain; and that some individuals, and chiefly Dr. Anderson and Elkington, began to practise it on new principles. About the same time, the study of geology became more general, and this circumstance led to the establishment of the art on scientific principles. The public attention was first excited by the practice of Elkington, a farmer and self-taught professor of the art of draining in Warwickshire and the adjoining counties. On the practice of this artist most of the future improvements have been founded; and they have been ably embodied in the account of his practice by Johnston, from whose work we shall draw the principal materials of this section, borrowing also from the writings of Dr. Anderson, Marshal, Smith, Farey, and some others on the same subject. After submitting some general remarks on the natural causes of wetness in lands, we shall consider in succession the drainage of boggy lands, hilly lands, mixed soils, retentive soils, and mines and quarries; and then the kinds of drains, and draining materials.

SECT. I. *Of the Natural Causes of Wetness in Lands, and the general Theory of Draining.*

3910. *The successful practice of draining* in a great measure depends on a proper knowledge of the structure of the earth's upper crust; that is, of the various strata of which it is composed, as well as of their relative degrees of porosity, or capability of admitting or rejecting the passage of water through them, and likewise the modes in which water is formed, and conducted from the high or hilly situations to the low or level grounds. In whatever way the hills or elevations that present themselves on the surface of the globe were originally formed, it has been clearly shown, by sinking large pits, and digging into them, that they are mostly composed of materials lying in a stratified order, and in oblique or slanting directions downwards. Some of these strata, from their nature and properties, are capable of admitting water to percolate or pass through them; while others do not allow it any passage, but force it to run or filtrate along their surfaces without penetrating them in any degree, and in that way to conduct it to the more level grounds below. There it becomes obstructed or dammed up by meeting with impervious materials of some kind or other, by which it is readily forced up into the super-incumbent layers where they happen to be open and porous, soon rendering them too wet for the purposes of agriculture; but where they are of a more tenacious and impenetrable quality, they only become gradually softened by the stagnant water below them; by which the surface of the ground is, however, rendered equally moist and swampy, though somewhat more slowly than in the former case. It may also be observed, that some of the strata which constitute such hilly or mountainous tracts are found to be continued with much greater

regularity than others; those which are placed nearest to the surface at the inferior parts of such hills or elevations, being mostly broken or interrupted before they reach the tops or higher parts of them; while those which lie deeper, or below them at the bottom, show themselves in these elevated situations. Thus, that stratum which may lie the third or fourth, or still deeper, at the commencement of the valley may form the uppermost layer on the summits of hills or mountainous elevations. This arrangement or distribution of the different strata may have been produced partly by the circumstances attending the original elevation of such mountainous regions, and partly from the materials of the original exterior strata being dissolved and carried down into the valleys by successive rains and other causes, and thus leaving such as were immediately below them in an exposed and superficial state in these elevated situations. (*Darwin's Phytologia*, p. 258.)

3911. *These elevated strata frequently prove the means of rendering the grounds below wet and swampy*; for, from the night dews, and the general moisture of the atmosphere, being condensed in much greater quantities in such elevated situations, the water thus formed, as well as that which falls in rain and sinks through the superficial porous materials, readily insinuate themselves, and thus pass along between the first and second, or still more inferior strata which compose the sides of such elevations; until their descent is retarded or totally obstructed by some impenetrable substance, such as clay; it there becomes dammed up, and ultimately forced to filtrate slowly over it, or to rise to some part of the surface, and constitute, according to the particular circumstances of the case, different watery appearances in the grounds below. These appearances are, oozing springs, bogs, swamps, or morasses, weeping rocks from the water slowly issuing in various places, or a large spring or rivulet from the union of small currents beneath the ground. This is obvious from the sudden disappearance of moisture on some parts of lands, while it stagnates, or remains till removed by the effects of evaporation on others; as well as from the force of springs being stronger in wet than dry weather, breaking out frequently after the land has been impregnated with much moisture in higher situations, and as the season becomes drier ceasing to flow, except at the lowest outlets. The force of springs, or proportion of water which they send forth, depends likewise, in a great measure, on the extent of the high ground on which the moisture is received and detained, furnishing extensive reservoirs or collections of water, by which they become more amply and regularly supplied. On this account, what are termed bog-springs, or such as rise in valleys and low grounds, are considerably stronger and more regular in their discharge, than such as burst forth on the more elevated situations or the sides of eminences. (*Johnston's Account of Elkington's Mode of Draining Land*, p. 15.)

3912. *The waters condensed on elevated regions* are sometimes found to descend, for a very considerable distance, among the porous substances between the different conducting layers of clayey or other materials, before they break out or show themselves in the grounds below; but it is more frequently the case to find them proceeding from the contiguous elevations into the low grounds that immediately surround them.

3913. *The nature of the stratum of materials on which the water proceeding from hills has to penetrate*, must considerably influence its course, as well as the effects which it may produce on such lands as lie below, and into which it must pass. Where it is of the clayey, stiff marly, or impervious rocky kinds, and not interrupted or broken by any other kind of materials of a more porous quality, it may pass on to a much greater distance, than where the stratum has been frequently broken and filled up with loose porous materials, in which it will be detained, and of course rise up to the surface.

3914. *These sorts of strata extend to very different depths in different situations and districts*, as has been frequently noticed in the digging of pits, and the sinking of deep wells, and other subterranean cavities. The clayey strata are, however, in general found to be more superficial than those of the compact, tenacious, marly kinds, or even those of a firm, uninterrupted, rocky nature, and seldom of such a great thickness; they have, nevertheless, been observed to vary greatly in this respect, being met with in some places of a considerable thickness, while in others they scarcely exceed a few inches.

3915. *The intervening porous substances*, or strata where clay prevails, are found, for the most part, to be of either a gravelly or loose rocky nature. Stiff marly strata, which approach much to the quality of clay, though in some instances they may present themselves near the surface, in general lie concealed at considerable depths under the true clayey strata, and other layers of earthy or other materials; they have been discovered of various thicknesses, from eight or ten feet to considerably more than a hundred. (*Darwin's Phytologia*, p. 259.) The intervening materials, where strata of this nature are predominant, are most commonly of the more sandy kinds; possessing various degrees of induration, so as in some cases to become perfectly hard and rocky, but with frequent breaks or fissures passing through them. The loose, friable, marly strata are capable of absorbing water, and of admitting it to filtrate and pass through them.

3916. *Thus the valleys and more level grounds must constantly be liable to be overcharged with moisture*, and to become, in consequence, spouty, boggy, or of the nature of a morass,

accordingly as they may be circumstanced in respect to their situation, the nature of their soils, or the materials by which the water is obstructed and detained in or upon them.

3917. *Where lands have a sufficient degree of elevation to admit of any over-proportion of inoisture readily passing away, and where the soils of them are of such an uniform sandy or gravelly and uninterrupted texture, as to allow water to percolate and pass through them with facility, they can be little inconvenienced by water coming upon or into them, as it must of necessity be quickly conveyed away into the adjacent rivers or small runlets in their vicinity.*

3918. *But where grounds are in a great measure flat, and without such degrees of elevation as may be sufficient to permit those over-proportions of moisture that may have come upon them from the higher and more elevated grounds, to pass readily away and be carried off; and where the soils of the lands are composed or constituted of such materials as are liable to admit and retain the excesses of moisture; they must be exposed to much injury and inconvenience from the retention and stagnation of such quantities of water. Such lands consequently require artificial means to drain and render them capable of affording good crops, whether of grain or grass.*

3919. *Lands of valleys and other low places, as well as, in some cases, the level tracts on the sides or borders of large rivers and of the sea, must also frequently be subject to great injury and inconvenience from their imbibing and retaining the water that may be thus forced to flow up into or upon them, either through the different conducting strata from the hills and mountainous elevations in the neighborhood, or the porous materials of the soils. In these ways they may be rendered swampy, and have bogs or morasses produced in them in proportion to the predominancy of the materials by which the water is absorbed and dammed up, and the peculiarity of the situation of the lands in respect to the means of conveying it away.*

3920. *To perform properly the business of draining, attention should not only be paid to the discrimination of the differences in regard to the situation of the lands, or what is commonly denominated drainage level; but also to the nature, distribution, and depth of the materials that constitute the soils or more superficial parts of them, as upon each of these some variety, in respect to the effects arising from water retained in them, may depend.*

3921. *Wetness of land, so far as it respects agriculture, and is an object of draining, may generally depend on the two following causes: first, on the water which is formed and collected on or in the hills or higher grounds, filtrating and sliding down among some of the different beds of porous materials that lie immediately upon the impervious strata, forming springs below and flowing over the surface, or stagnating underneath it; and secondly, on rain or other water becoming stagnant on the surface, from the retentive nature of the soil or surface materials; and the particular nature of the situation of the ground. The particular wetness which shows itself in different situations, in the forms of bogs, swamps, and morasses, for the most part proceeds from the first of these causes; but that superficial wetness which takes place in the stiff, tenacious, clayey soils, with little inclination of surface, generally originates from the latter.*

3922. *The most certain and expeditious method of draining, in such cases, is that of intercepting the descent of the water or spring, and thereby totally removing the cause of wetness. This may be done where the depth of the superficial strata, and consequently of the spring, is not great; by making horizontal drains (fig. 483 a) of consi-*

483

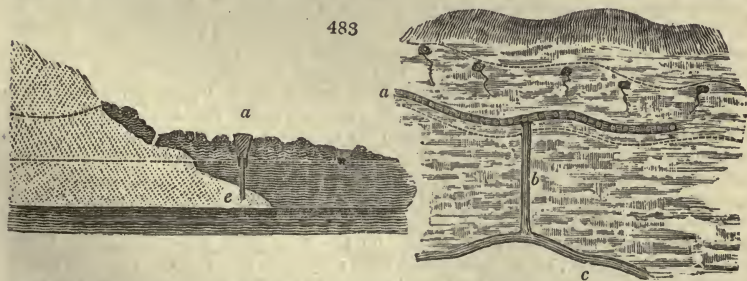

derable length across the declivities of the hills, about where the low grounds of the valleys begin to form, and connecting these with others (b) made for the purpose of conveying the water thus collected into the brooks or runlets (c) that may be near. Where the spring has naturally formed itself an outlet, it may frequently only be necessary to bore into it (c) or render it larger, and of more depth; which, by affording the water a more free and open passage, may evacuate and bring it off more quickly, or sink it to a level so greatly below that of the surface of the soil, as to prevent it from flowing into or over it.

3923. *Where the uppermost stratum is so extremely thick as not to be easily penetrated, or where the springs, formed by the water passing from the higher grounds, may be confined beneath the third or fourth strata of the materials that form the declivities of hills or elevated grounds, and by this means lie too deep to be penetrated to by the cutting of a ditch, or even by boring (Darwin's Phytologia, p. 263.); the common mode of cutting a great number of drains to the depth of five, six, or more feet, across the wet morassy grounds, and afterwards covering them in such a manner as that the water may suffer no interruption in passing away through them, may be practised with advantage, as much of the prejudicial excess of moisture may by this means be collected and carried away, though not so completely as by fully cutting off the spring.*

3924. *As water is sometimes found upon thin layers of clay, which have underneath them sand, stone, or other porous or fissured strata, to a considerable depth; by perforating these thin layers of clay in different places, the water which flows along them may frequently be let down into the open porous materials that lie below them, and the surface land be thus completely drained.*

3925. *Where morasses and other kinds of wetnesses are formed in such low places and hollows as are considerably below the beds of the neighboring rivers, they may, probably, in many instances, be effectually drained by arresting the water as it passes down into them from the higher grounds, by means of deep drains cut into the sides of such hills and rising grounds, and, after collecting it into them, conveying it away by pipes, or other contrivances, at such high levels above the wet lands as may be necessary: or where the water that produces the mischief can by means of drains, cut in the wet ground itself, be so collected as to be capable of being raised by means of machinery, it may in that way be removed from the land.*

3926. *The drainage of lands that lie below the level of the sea, can only be effected by the public, and by means of locks erected for the purpose of preventing the entrance of the tides, and by wind-mills and other expensive kinds of machinery constructed for the purpose of raising the stagnant water.*

3927. *The superficial wetness of lands, which arises from the stiff retentive nature of the materials that constitute the soils and the particular circumstances of their situations, is to be removed in most cases by means of hollow surface drains, judiciously formed, either by the spade or plough, and filled up with suitable materials where the lands are under the grass system; and by these means and the proper construction of ridges and furrows where they are in a state of arable cultivation.*

3928. *Having thus explained the manner in which soils are rendered too wet for the purposes of agriculture, and shown the principles on which the over-proportions of moisture may, under different circumstances, be the most effectually removed, we shall proceed to the practical methods which are to be made use of in accomplishing the business in each case.*

## SECT. II. *Of the Methods of Draining Boggy Land.*

3929. *In the drainage of wet or boggy grounds, arising from springs of water beneath them, a great variety of circumstances are necessary to be kept in view. Lands of this description, or such as are of a marshy and boggy nature, from the detention of water beneath the spongy surface materials of which they are composed, and its being absorbed and forced up into them, are constantly kept in such states of wetness as are highly improper for the purpose of producing advantageous crops of any kind. They are, therefore, on this account, as well as those of their occupying very extensive tracts in many districts, and being, when properly reclaimed, of considerable value, objects of great interest and importance to the attentive agriculturist. Wet grounds of these kinds may be arranged under three distinct heads: first, such as may be readily known by the springs rising out of the adjacent more elevated ground, in an exact or regular line along the higher side of the wet surface; second, those in which the numerous springs that show themselves are not kept to any exact or regular line of direction along the higher or more elevated parts of the land, but break forth promiscuously throughout the whole surface, and particularly towards the inferior parts (fig. 484 a), constituting shaking quags in every direction, that have an elastic feel under the feet, on which the lightest animals can scarcely tread without danger, and which, for the most part, show themselves by the luxuriance and verdure of the grass about them; that sort of wet land, from the oozing of springs, which is neither of such great extent, nor in the nature of the soil so peaty as the other two, and to which the term bog cannot be strictly applied, but which in respect to the modes of draining is the same. (Johnston's Account of Elkington's Mode of Draining Land, p. 19.)*

3930. *In order to direct the proper mode of cutting the drains or trenches in draining lands of this sort, it will be necessary for the draining engineer to make himself perfectly acquainted with the nature and disposition of the strata composing the higher grounds, and the connection which they have with that which is to be rendered dry. This may in*



484



general be accomplished by means of levelling and carefully attending to what has been already observed respecting the formation of hills and elevated grounds, and by inspecting the beds of rivers, the edges of banks that have been wrought through, and such pits and quarries as may have been dug near to the land. Rushes, alder-bushes, and other coarse aquatic plants, may also, in some instances, serve as guides in this business; but they should not be too implicitly depended on, as they may be caused by the stagnation of rain-water upon the surface, without any spring being present. The line of springs being ascertained, and also some knowledge of the substrata, a line of drain (fig. 484 b, b) should be marked out above or below them, according to the nature of the strata, and excavated to such a depth as will intercept the water in the porous strata before it rises to the surface. The effect of such drains will often be greatly heightened by boring holes (c) in their bottom with the auger. Where the impervious stratum (fig. 485 a), that

485

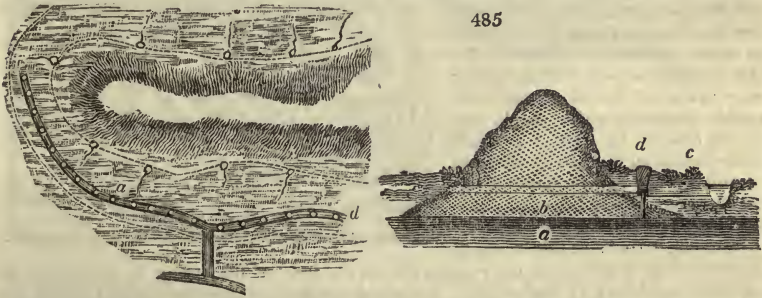

lies immediately beneath the porous (b), has a slanting direction through a hill or rising bank, the surface of the low lands will, in general, be spongy, wet, and covered with rushes on every side (c). In this case, which is not infrequent, a ditch or drain (d), properly cut on one side of the hill or rising ground, may remove the wetness from both. But where the impervious stratum dips or declines more to one side of the hill or elevation than the other, the water will be directed to the more depressed side of that stratum; the effect of which will be, that one side of such rising ground will be wet and spongy, while the other is quite free from wetness.

3931. Where water issues forth on the surface at more places than one, it is necessary to determine which is the real or principal spring, and that from which the other outlets are fed; as by removing the source, the others must of course be rendered dry. When on the declivity or slanting surface of the elevated ground from which the springs break forth, they are observed to burst out at different levels according to the difference of the wetness of the season, and where those that are the lowest down continue to run, while the higher ones are dry, it is, in general, a certain indication that the whole are connected, and proceed from the same source; and consequently that the line of the drain should be made along the level of the lowermost one, which, if properly executed, must keep all the others dry. But if the drain was made along the line of the highest of the outlets, or places where the water breaks forth, without being sufficiently deep to reach the level of those below, the overflowings of the spring would merely be carried away, and the wetness proceeding from that cause be removed; while the main spring, still continuing to run, would render the land below the level of the bottom of the drain still prejudiciously wet, from its discharging itself lower down over the surface of the ground. This, Johnston states, was the custom, until Elkington showed the absurdity of the practice of drainers beginning to cut their trenches wherever the highest springs showed themselves between the wet and the dry ground, which not being of a depth sufficient to arrest and take away the whole of the water, others of a similar kind were under the

necessity of being formed at different distances, to the very bottom of the declivity : these being afterwards in a great measure filled with loose stones, merely conveyed away portions of surface water, without touching the spring, the great or principal cause of the wetness. The effects of drains formed in this manner he asserts to be, that of rendering the surface of the land in some degree drier, so long as they continue to run with freedom ; but as they are liable soon to be obstructed and filled up by sand or other materials, the water is often forced out 'in different places and directions, and thus renders the land equally wet, if not more so, than it was before. In addition to this, it is a more difficult task to drain the ground a second time in a proper method, from the natural appearance of the ground being so much changed, and the bursts of the old drains, as well as the greater difficulty of ascertaining the real situation of the springs.

3932. It may sometimes happen, however, that *where the highest are the strongest outlets, they may be the main or leading springs* ; those which show themselves lower down in the land being merely formed by the water of the main spring overflowing, and finding itself a passage from an opening, or the porous nature of the materials of the soil near to the surface, and from being obstructed somewhat further down in the ground by some impervious stratum. This circumstance must, therefore, it is observed, be fully ascertained before the lines for the ditches or drains are marked out.

3933. In cases *where the banks or rising grounds are formed in an irregular manner* (fig. 486.), and from the nature of the situation, or the force of the water under-

neath, springs abound round the bases of the protuberances, the ditches made for the purpose of draining should always be carried up to a much higher level in the side of the elevated ground than that in which the water or wetness appears ; as far even as to the firm unchanged land. By this means the water of the spring may be cut off, and the ground completely drained ; which would not be the case if the trench or drain were formed on the line of the loose materials lower down where the water oozes out, which is liable to mislead the operator in forming the conducting trench, or that which is

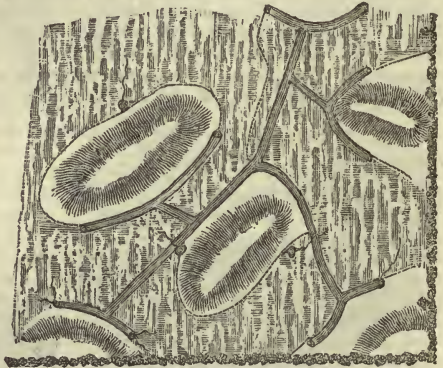

to convey the water from the cross-drain on the level of the spring to the outlet or opening by which it is discharged. But where the main or principal spring comes out of a perpendicular or very steep bank, at a great height above the level of the outlet into which it may discharge itself by means of a drain ; it will neither be necessary nor of any utility to form a deep trench, or make a covered drain, all the way from such outlet up to it ; as from the steepness of the descent the water would be liable, when the drain was thus cut, from the thin strata of sand, and other loose materials, always found in such cases, to insinuate itself under the bricks, stones, or other substances of which the drain was formed ; to undermine and force them up by the strength of the current, or, probably, in some instances, block the drain up by the loose sand or other matters, which may be forced away and carried down by it. In situations of this kind, Johnston observes, it is always the best way to begin just so far down the bank or declivity as, by cutting in a level, the drain may be six or seven feet below the level of the spring ; or of such a depth as may be requisite to bring down the water to a level suitable to convey it away without its rising to the surface, and injuring the lands around it. The rest of the drain, whether it be made in a straight or oblique direction, need not be deep, and may, in many instances, be left quite open ; it should, however, be carefully secured from the treading of cattle, and, where the land is under an arable system of cultivation, also from the plough. Where it is covered, the depth of about two feet may be sufficient. There will not, in such drains, be any necessity for the use of the auger in any part of them.

3934. Where there is a *difficulty in ascertaining the line of the spring*, and consequently that of the cross drain, either from its not showing itself on the surface, or from there not being any apparent outlet, it may, generally, be met with in carrying up the conducting drain for conveying away the water : as soon as the operator discovers the spring, he need not proceed any further, but form the cross drain on the level thus discovered to such a distance on each side of the tail, or terminating part of the strata, of whatever sort, that contains the water, as the nature of the land, in regard to situation or other circumstances, may demand. Where, in forming a cross-drain, the line indicated by the spirit or

other level is found to be in some places below that of the spring, and where, in boring in this direction, water is not found to follow, it will be necessary to make short drains or cuts of the same depth with the cross-drain, from it quite up to the source of the spring; for, if the drain be cut below the line of the spring, the possibility of reaching it by means of an auger is lost, as where the under stratum is clay, and there is no under water, the use of the auger cannot be effectual; and if it be made above the line of the spring, it will be requisite to cut and bore much deeper, in order to reach it, the ground being in general higher in that part: besides, the portion of porous stratum below the drain may contain a sufficient quantity of water to render the land wet, and that may readily get down underneath the trench, between the holes formed by boring, and break out lower down.

3935. In situations where the extent of bog in the valley between two banks or eminences is so narrow and limited as that the stratum of rock, sand, or other materials that contains the water, may unite below the clay at such a depth as to be readily reached by the auger (fig. 487 a), it will seldom be necessary to have more than one trench up the middle,

487

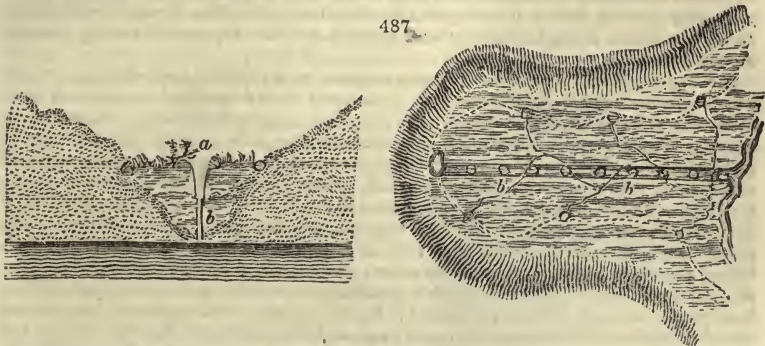

well perforated with holes (b) by means of the auger; cross or branching drains being unnecessary in such cases. For notwithstanding the springs, that render the land injuriously wet in these cases, burst out of the banks or eminences on every side, for the most part nearly on the same level, the reservoir from which they proceed may be discovered in the middle of the valley, by penetrating with the auger through the layer of clay, that confines and forces the water to rise up and ooze out round the superior edge of it, where it forms an union with the high porous ground. From the drain being made in the hollowest part of the land, and the porous stratum containing the water being then bored into, it is obvious that the ditch or drain thus formed being so much lower than the ordinary outlet of the springs, the pressure of water above that level, which is the bottom of the drain, must be such as to force that which is under the drain or trench through the holes made by the auger, and in many instances, until a considerable quantity of the water is evacuated, make it rise to a greater height than the level of its natural outlet. The effect of which must be, that the water forming the spring, having found by these means a fresh and more easy passage, will quickly relinquish its former openings, and thus be prevented from running over and injuring the ground, that previously lay lower down than it.

3936. But in swamps or bogs that are extensive and very wet, other drains or cuts than such as convey off the springs must be made; as, notwithstanding the higher springs which chiefly cause the wetness may be intercepted, there may be lower veins of sand, gravel, or other porous materials, from which the water must likewise be drawn off. In cases of this nature, where the land is to be divided into enclosures, the ditches may be formed in such directions as to pass through and carry off collections of water of this kind, as well as those that may be retained in the hollows and depressions on the surface of the land. There are in many places very extensive tracts of ground that are rendered wet, and become full of rushes and other coarse plants, from causes of such a nature as cannot be obviated by the making of either open or covered drains, however numerous they may be. Lands in this situation are frequently termed holms, and mostly lie on the sides of such rivers and brooks as, from the frequency of their changing and altering their courses between their opposite banks, leave depositions of sand, gravel, and other porous materials, by which land is formed, that readily admits the water to filtrate and pass through it to the level of the last-formed channels, and which preserves it constantly in such a state of moisture and wetness, as to render it productive of nothing but rushes and other aquatic plants; and if a pit or ditch be made in lands under these circumstances, it quickly fills with water to the same level as that in the watercourse. This effect is, however, more liable to be produced, as well as more complete, where the current of the

water is slow, and its surface nearly equal with that of the land, than where its descent is rapid. Under such circumstances, while the river or brook remains at the ordinary height, no advantage can be gained, whatever number of drains be formed, or in whatever direction they may be made. The chief or only means of removing the wetness of land proceeding from this cause is, that of enlarging and sinking the bed of the stream, where it can be effected at a reasonable expense: where there is only one stream, and it is very winding or serpentine in its course, much may however be effected by cutting through the different points of land, and rendering the course more straight, and thereby less liable to obstruct the passage of the water. But in cases where there are more than one, that should always be made the channel of conveyance for draining the neighboring land, which is the lowest in respect to situation and the most open and straight in its course. It may likewise, in particular instances, be advantageous to stop up and divert the waters of the others into such main channels, as by such means alone they may often be rendered deeper, and more free from obstruction: the materials removed from them may serve to embank and raise up the sides to a greater height, as while the water can rise higher than the outlets of the drains, and flow backwards into them, it must render the land as wet as it was before they were formed, and the expense of cutting them be thrown away.

3937. *The collected rain-water becoming stagnant on a retentive body of clay, or some other impervious material, as it can have no outlet of the natural kind, causes such lands to become soft and spongy, thus forming bogs of a very confined kind. As such bogs are often situated very greatly below the ground that surrounds them, the opening of a main drain, or conductor, to convey off the water collected by smaller drains, would be attended, in many instances, with an expense greater than could be compensated by the land after it had been drained. The thickness of the impervious stratum that retains and keeps up the water in such cases is often so great, that though the stratum below be of a porous and open nature, such as sand, rock, or gravel, the water cannot of itself penetrate or find a passage from the one into the other; consequently, by its continued stagnation above, all the different coarse vegetable productions that have for a great length of time been produced on its surface, and probably the upper part of the soil itself, are formed into a mass or body of peat earth, equally soft and less productive than that of any bog originating from water confined below, and which is only capable of sustaining the weight of cattle in very dry seasons, when the wind and sun have exhaled and dried up a great part of its surface moisture; but even then it is incapable of admitting the plough upon it.*

3938. *As the cause of these kinds of bogs is materially different from that of those which have been already noticed, their drainage must of course be accomplished in a different way. The following method of proceeding is recommended as perhaps the least expensive. In the middle, or most depending part of the ground, the first drain (fig. 488 a), may be cut, into which all the others should be made to lead; the number and direction of which must be regulated by the extent of the bog. They should be cut through the peat, or moist spongy upper soil, to the surface of the clay, or other retentive stratum of materials, which must then be perforated or bored through in order to let the water down into the pervious stratum below, by which it may be absorbed and taken up. The same effect might be produced by forming one large well, or pit, in the middle or lowest part of the bog, by digging through into the porous stratum below, and connecting*

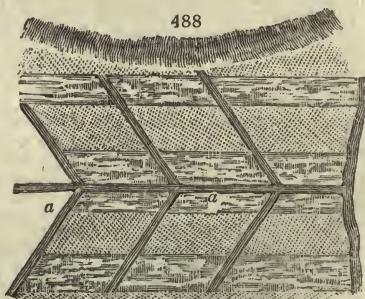

the other drains with it, as by such a method the trouble and expense of boring along the drains would be saved. In these cases, when drains are made, they should always be cut as narrow as it is possible to make them, and after the holes have been formed in them by boring, filled up with loose stones to within about a foot and a half of the surface, which space may be made up by a portion of the earth that had been taken out, putting in turf with the green side to the stones before the earth is thrown in. By this means the water and prejudicial moisture of the peat, or upper soil, may be taken away by the drains, and pass off through the holes that have been formed in their bottoms. But where pits are employed, these should only be filled with small stones to the level of the bottom of the drain, the filling being performed as soon as possible after they are formed (*Anderson's Treatise on Draining*, p. 88.); where there is a chalky stratum below, after taking it out, the flints contained in it may be made use of in this way with much advantage; and where the drains can be carried into quarries, where the stone is much fissured, nothing more will be necessary. Where land of this sort is afterwards to be ploughed, great attention should be

given to the forming of the ridges and giving them a regular descent towards the main drain, which will contribute greatly to the assistance of the others in conveying off heavy falls of rain-water when they occur.

3939. But a *necessary precaution* previous to any attempt to drain lands of this kind in the way that has been described, is to ascertain whether the porous stratum under the clay be dry, and capable of receiving the water when let down into it; or already so loaded with moisture itself, as, instead of receiving more from above, to force up a large quantity to the surface, and thus increase the evil it was intended to remove. This may be the case in many instances, and the substratum contain water which affords no appearances of wetness on the surface, at the place, on account of the compact body of clay that is placed over it, but which, from its being connected with some spring that is higher, may flow up when an opening or passage is given it, either by means of a pit or the auger. In this way a greater quantity of water might be brought to the surface, which, from its being confined by the surrounding banks, would render the ground much more wet than before, and in particular situations produce very great degrees of wetness. When the surrounding high ground declines lower than the bog, though it may be at a considerable distance, by the aid of the level, and the appearance of the surface, the nature of the stratum underneath may, in some degree, be ascertained; and, notwithstanding it may already contain water, a drain may be formed into it to carry off that water, and what may likewise be let down into it from the retentive stratum that lies above it. It must be confessed, however, that cases where surface water can be let down through a retentive stratum to a porous one that will actually carry it off, are very rare. When these occur, it is chiefly in limestone or coaly districts, where the surface is hilly or rugged (fig. 489.), and more calculated for the pursuits of the mineralogist than the agriculturist.

3940. *Draining hilly lands* is not in general attended with great expense, as the drains need seldom be covered or filled up, only in such places as may be sufficient for passages for the animals to cross by. And though, where the depth of the trench does not come to the water confined below, it may be necessary to perforate lower, there need not be any fear that the holes will fill up, even where the drain is left open; as the impetuosity of the water itself, will remove any sand or mud that may fall into them, where much flood or surface water does not get in. Small openings may, however, be made along the upper side of the trench, in order the more effectually to secure them against any obstructions; and in these the perforations may be made, leaving the mouth of the holes about six inches higher than the bottom of the drain, which will be without the reach of the water that may be collected during the time of heavy rains.

3941. *The sides or declivities of many hills*, from the irregularity of the disposition of the strata that compose them, are often covered with alternate portions or patches of wet and dry ground. By the general appearance of the surface and the vegetable products that are grown upon it, the nature and direction of the internal strata may frequently be ascertained with so much certainty as to determine the line or direction of a drain without the necessity of examining below the surface of the land. As the ease or difficulty of draining such grounds depends solely on the position of the different strata of which the hill or elevation may be formed, and upon the erect or slanting direction of the rock, or other retentive body in which the water is contained; where the rock has a slanting or horizontal inclination, the whole of the different springs or outlets, that show themselves on the surface, may originate from or be connected with the same collection or body of water, and may be all drained and dried up by cutting off, or letting out, the main body of water, by which they are supplied, at the inferior part of the reservoir, or that part where the water would of its own accord readily run off if it were not confined beneath an impervious covering of clay or some other material.

3942. But in cases where the rock lies in an erect or perpendicular form, and contains only partial collections of water, in some of the more open cracks or fissures of the stone, that discharge themselves at various openings, or outlets, that have not the least connection with each other, it would be an idle and fruitless endeavor to attempt the cutting of them off by means of one drain (fig. 490 a), or by boring into any one of them in particular, without cutting a drain into each (a, b, c). In this case it is more advisable to make the main drain wholly in the clay, with small cuts made up to each outlet, than along the place where the springs burst out; as in that line of direction it would be too greatly in

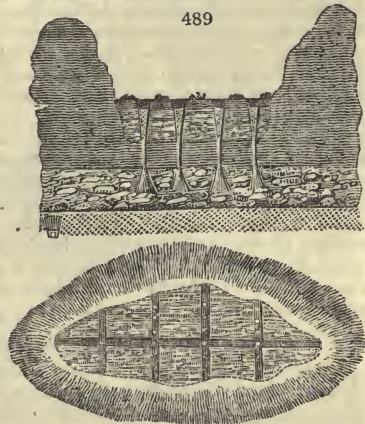

the rock, and consequently be extremely difficult to cut, on account of the nature and disposition of the stone: when the water passing out on the line of the springs can be found by the auger in the main drain, at the point where it joins it, it will, it is observed, be the more completely cut off; but where this is not practicable, the depth of the small cuts may reduce it to such a level as will prevent its flowing over and injuring the surface of the land below it.

3943. In such hills as are constituted of alternate strata of rock, sand, and clay, the surface of the latter may frequently be wet and swamp, while that of the former is dry, and capable of producing good crops of grass; in all such cases, in order to drain the land completely, as many cuts will be necessary as there may happen divisions of wet and dry soil: the summit, or most elevated part of such hills, being mostly formed of loose porous materials, through which the rain and other water descends, till its passage becomes obstructed by some impervious bed or stratum, such as clay, when it is forced up to the surface, and runs or oozes over the obstructing stratum; and after having overflowed, the upper clay surface is immediately absorbed and taken up by the succeeding porous one, and, sinking into it in the same way as before, passes out again at the lower side of it, and renders the surface of the next clayey bed prejudicially wet as it had done in the first. In this way the same spring may affect all the other strata of the same kind of which the hill consists, from the highest part down the whole of the declivity, and produce in the bason, or hollow at the bottom, a lake or bog, should there not happen to be a passage or opening to take away the water. In order effectually to drain hills of this kind, it will be the most advisable to begin by forming a trench along the upper side of the uppermost rushy soil, by which means the highest spring may be cut off; but as the rain and other water that may come upon the next portion of porous soil may sink down through it to the lowest part, and produce another spring, a second cut must be made in that part to prevent the water from affecting the surface of the succeeding clayey bed. And similar cuts must be formed so far down the declivity as the same springs continue in the same way to injure the land, and in some cases a sufficiency of water may probably be obtained to irrigate the land below, or some other useful purpose.

### SECT. III. Of the Methods of draining Mixed Soils.

3944. Where the soil is of a mixed and varied nature, but the most prevailing parts of the clayey kind, the business of draining is considerably more tedious and difficult than where the superficial and internal parts have greater regularity. In such sorts of lands, as all the different collections of water are perfectly distinct from each other, by means of the beds of clay that separate them, each collection becomes so much increased, or accumulated, in the time of heavy rains, that they are filled quite to the level of the surface of the clay by which they are surrounded; when the water getting a free passage, as it would over the edges of a bowl or dish, overflows and saturates the surface of that bed of clay in such a manner, as to render it so perfectly wet and sour, that its produce becomes not only annually more and more scanty, but the soil itself more sterile and unproductive.

3945. From the sand-beds (fig. 491 a, a, a) in such cases having no communication with each other, it must evidently require as many drains (b, b, b) as there are beds of this kind, in order fully to draw off the water from each of them. A drain or trench is therefore recommended to be cut from the nearest and lowest part of the field intended to be drained (c), up to the highest and most distant sand-bank (d), in such a line of direction as, if possible, to pass through some of the intermediate sand-beds, and prevent the labor and expense of making longer cuts on the sides, which would otherwise be requisite.

3946. Where the different beds of sand and clay are of less extent, and lie together with greater regularity, they can be drained in a more easy manner with less cutting, and of course at less expense. Below the layers or beds of sand and clay that lie, in this manner, alternately together, and nearly parallel to each other, is generally a body

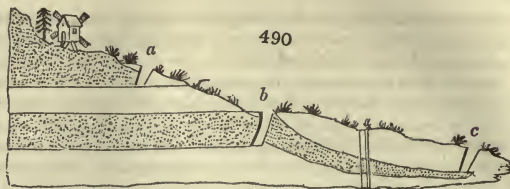

of impervious clay, which keeps up the water that is contained in the sand, and which, being constantly full, renders the adjacent clay moist, and in wet seasons runs or trickles over it. As in these cases, the principal under-stratum of clay is rarely above four or five feet below the surface, a drain (*fig. 492 a*) is advised to be cut to that depth through the middle of the field, if it have a descent from both sides; but if it decline all to one

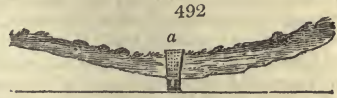
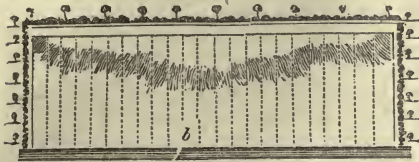

side, the drain must be made in that place (*b*), as the water will more readily discharge itself into it; and, unless the field be of great extent, and have more depressions or hollows in it than one, one drain may be quite sufficient for the purpose, as by crossing the different beds that retain the water, it must take it off from each of them.

3947. A principal difficulty in draining ground of this nature, and which renders it impracticable by one drain, is when the direction of the alternate layers, or beds of clay and sand, lie across the declivity of the land (*fig. 493 a, a*), so that one drain can be of no other service than that of conveying away the water after it has passed over the different strata, and would naturally stagnate in the lowest part of the field, if there was no other passage for it. Where the land lies in this way, which is frequently the case, it will therefore be necessary, besides the drain in the lowest part (*b*), to have others cut up from it in a slanting direction across the declivity (*c, c*), which, by crossing all the different veins, or narrow strata of sand (*d, d, d,*) may be capable of drawing the water from each of them.

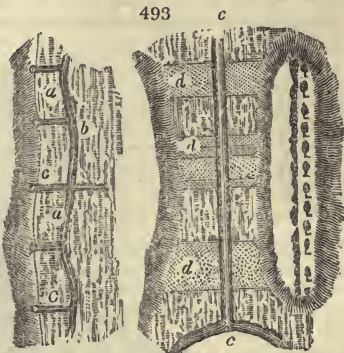

3948. In forming the drains in these cases, it is recommended that, after laying the bottom in the manner of a sough, or in the way of a triangle, it be filled some way up by small stones, tough sods being applied, the green side downwards upon them before the mould is filled in. But where stones cannot be readily procured, faggots may be employed in their place where they are plentiful: the under part of the drain being laid, or coupled with stones, so as to form a channel or passage for the conveyance of the water that may sink through the faggots, and for the purpose of rendering them more durable; as where the water cannot get freely off, which is generally the case where there is not an open passage made of some solid material, it must, by its stagnation, soon destroy the faggots, and choke up the drain.

SECT. IV. *Of the Methods of draining Retentive Soils.*

3949. The practical mode of draining retentive soils, is materially different from that which has been described above. Many tracts of level land are injured by the stagnation of a superabundant quantity of water in the upper parts of the surface materials, which does not rise up into them from any reservoirs or springs below. The removal of the wetness in these cases may, for the most part, be effected without any very heavy expense. From the upper or surface soil in such cases, being constituted of a loose porous stratum of materials, to the depth of from two to four or five feet, which has a stiff retentive body of clay underneath it, any water that may come upon the surface from heavy rains, or other causes, readily filtrates and sinks down through it, until it reaches the obstructing body of clay which prevents it from proceeding; the consequence of which is, that the porous open soil above is so filled and saturated with water, as to be of little utility for the purpose of producing crops of either grain or grass. Land situated in this way, is frequently said by farmers to be wet-bottomed. In order to remove this kind of wetness, it seldom requires more than a few drains, made according to the situation and extent of the field, of such a depth as to pass a few inches into the clay, between which, and the under surface of the porous earth above, there will obviously be the greatest stagnation, and consequently, collection of water, especially where it does not become much visible on the surface. In these cases there is not any necessity for having recourse to the use of the boring instrument, as there is no water to be discharged from below.

3950. When the field to be drained has only a slight declination, or slope, from the sides towards the middle, one drain cut through the porous superficial materials into the clay,

in the lowest part of the ground (fig. 494 a), may be sufficient to bring off the whole of the water detained in the porous soil. This effect may likewise be greatly promoted, by laying out and forming the ridges so as to accord with the direction of the land, and by the use of the plough or spade in removing obstructions, and deepening the furrows. In such situations, where the drain has been formed in this manner, the water will flow into it through the porous surface materials, as well as if a number of small trenches were cut from it to each side, as is the practice in Essex and some other parts of the country; but which is often an unnecessary labor and expense. The drain made in the hollow may frequently serve as a division of the field (a), in which case it may be open; but in other circumstances it may be more proper to have it covered.

494

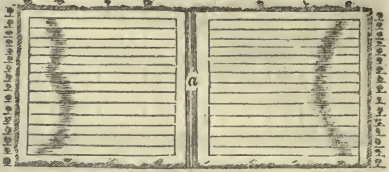

3951. Where a field of this description has more than one hollow in its surface (fig. 495 a, b), it will obviously be requisite to have more than one main drain; but when it is nearly level, or only inclines slightly to one side, a trench or drain along the lowest part, and

495

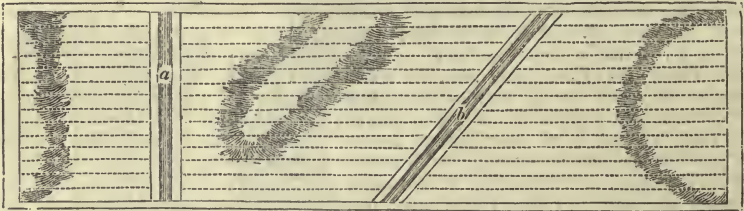

the ridges and furrows formed accordingly, may be sufficient for effecting its drainage. There may, however, be cases, as where a field is large and very flat, in which some side-cuts from the principal drain may be necessary, which must be made a little into the clay, and as narrow as they can be wrought, and then filled up with stones or other suitable materials.

3952. What is called the Essex method of draining in ploughed springy lands, where the surface soil is tenacious, is described by Kent, and consists in substituting small under-drains (fig. 496 a) for open furrows; or in some cases having a small under-

496

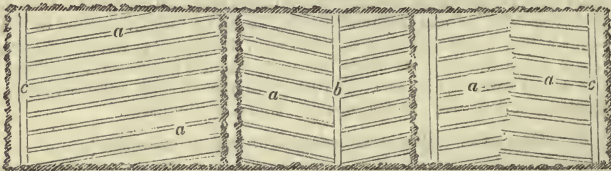

drain beneath (b, b) every other or every third furrow. These drains lead to side or fence ditches (c), where they discharge themselves.

3953. Where the clay constitutes the surface, and the porous body is underneath, the injurious stagnant water cannot possibly get off, without the assistance of drains being formed for the purpose. Soils of this nature are drained with difficulty, and require a much greater number of trenches or cuts than those of any other kind, as they must be marked out and disposed in such a way as to collect and convey the water every where from the surface; as it can only force itself off into them from above, being prevented from sinking in through the clay, as in those soils of a contrary kind. Where there happens to be hollows or irregularities in the surface of the land, water may often be observed to continue standing in them, at the distance of but a few feet from the drain. In draining such lands, it will always be necessary, in the first place, to make a large or conducting drain at the lowest part, or the end of the field, for the purpose of receiving and conveying away the water collected by the less collateral cuts which it may be necessary to make on each side of it. Where it suits for the purpose of dividing the land, this principal drain may be better to remain open than be covered, as by that means the mouths or outlets of the different small drains that come into it may be conveniently examined, and cleared out when necessary.

3954. The construction of the ridges in such soils, so as they may accord with the declivity, is a matter that must be carefully kept in view. They should in all such cases have, also, that degree of elevation or roundness in the middle, that may be suffi-



cient to afford the water a ready fall into the furrows, which should likewise have such a depth and fall as may take it quickly into the drains. The ridges, besides being well laid up, should have small open drains formed in a slanting direction across them, in such a manner as to form communications with one another, and with the furrows; by which means they are made to perform the office of drains, the water coming upon the ridges being thus readily conveyed into the furrows, where it proceeds till impeded in its course by the rising of the ground or other causes; it then passes through the open cross-drains into others where the descent is greater, and is ultimately conveyed off into the ditch, or other passage, at the bottom of the enclosure. The elevation of the ridges should probably too, be made greater for the winter than the summer crops, as there must be much more injurious moisture at the former than the latter season. This may be easily accomplished at the time of ploughing the land. Some useful observations on this description of drainage will be found in Marshal's work on *Landed Property*, and in Dr. Anderson's *Treatise on Draining*.

SECT. V. *Methods of draining Mines, Quarries, and Pits.*

3955. Where pits, mines, or quarries, happen to be formed at the bottom of declivities, and are inconvenienced or wholly obstructed, either in the digging or working, by the water contained in them, it may be possible, in many cases, to prevent its coming into such mines or pits, by cutting or boring into the lower parts of the porous strata (*fig. 497 a*). In order to accomplish this object, it will be necessary to ascertain if any

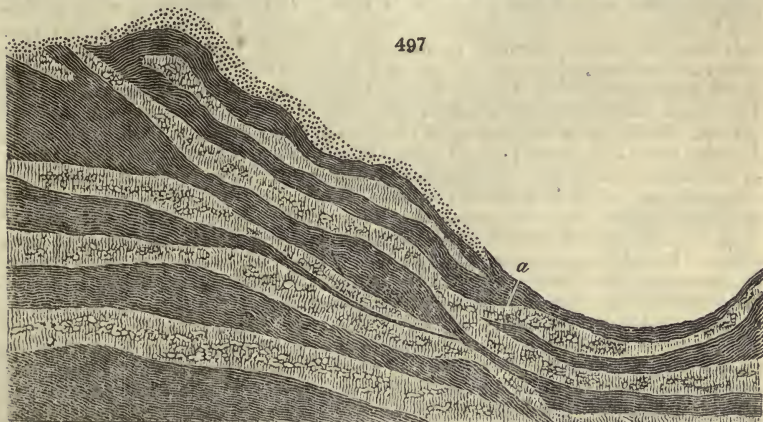

porous stratum presents itself higher up the elevation than the place where the mine or pit is formed, that may conduct the water it possesses to the porous body that is below it; as, where such a stratum is discovered by cutting into it, much of the water may be drawn off and prevented from passing down. But notwithstanding the water from above may be cut off in this way, a quantity sufficient to inconvenience the working of the mine or pit may still filtrate from the sides of the porous bed, even though it may incline in the direction of the lower ground. When this is the case, it may, however, be readily taken away at some place in it. To accomplish this, and thereby obviate the effects of the water, the termination of the porous stratum (*fig. 497 a*) below the pit must be ascertained; and where there is any mark of a natural outlet at the place, a large drain should be formed, in order to admit the water to flow off with more expedition. Where, however, there is a thick bed of some impervious substance, such as clay, placed upon the termination of the porous material, the drain need only be cut a little way into that, as by boring through the rest a sufficient passage may be given to discharge the water. In this way, the draining of such grounds as lie above or near to mines or pits may be of great advantage.

3956. Where a quarry or other pit to be dried (*fig. 498 a*) is situated above a porous stratum, whether of rock or gravel it may sometimes be drained by boring into the latter (*b*). In this way different chalk pits and lime quarries have been

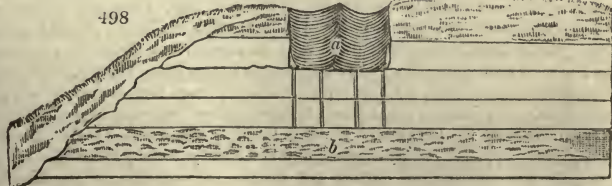

drained in Kent and Hertfordshire. (*See the Reports of these Counties.*) In marl-pits also, which, from the nature of their situation, mostly require much cutting through some part of their sides, in order to remove the water that prevents their being wrought, the mode of letting the water down by means of pits dug through the upholding stratum below the bed of marl into the porous materials underneath, might be economically practised. In such cases, the number of the pits must be proportioned to the space occupied by the marl; and when they are required to be of such depths as to be liable to give way, they should be built up, or nearly filled with loose stones, so as to admit the water to pass off; such lateral drains as are necessary communicating with them. In some situations of the pits, as where the bank slopes lower on the contrary side than the level of the water, an easier mode may be practised; such as by forming a drain in it, and then perforating with a horizontal boring instrument into the terminating part of the stratum that holds the water; thereby removing and keeping it below the level of the marl. And in addition to these, in some cases, as where the water of such pits proceeds from springs in the high grounds above them, it may be useful to intercept and convey it away before it reaches the marl-pits.

SECT. VI. *Of the Formation of Drains, and the Materials used in filling them.*

3957. *Drains should be formed with as much truth and exactness as possible; such laborers as are not dexterous in using their tools seldom make them well.* The most general method of performing this sort of work is by admeasurement, at so much a rod, or a score rods, which necessarily induces the workmen to do as much as they possibly can; they should, therefore, be frequently inspected, to see that they keep to the proper and required depth, and that the earth taken out be laid in such a manner as not to fall down again into the drains in time of filling them, and that the surface-mould be kept on one side free from the clayey or other material of the inferior stratum.

3958. *When there is any declivity in the ground, drains should be made in a slanting direction across it, instead of the old method of conducting them according to the nature or inclination of the slope.* By attending to the former mode of cutting the drains, the wetness is not only more effectually removed, but, by allowing the water to pass away in an easy current, they are rendered less liable to be choked, or, as it is frequently termed, blown up, by which artificial oozings of water are sometimes formed in such places. But where grounds are either quite or nearly level, it has long been a general practice to cut the drains at the different distances of about sixteen, twenty-four, and thirty-two feet from each other, across the fields from the different ditches, according to the circumstances of the lands; or, indeed, where the drains, either from some slight unevenness of the surface, or other causes, can only be made to flow at one end, to avoid cutting them further on one side than where the ditch is capable of taking away the wetness. In cases where the declivities of a piece of ground are various, and have different inclinations, the drainer should constantly attend to them, and direct the lines of his drains in such a manner as that they may cross the higher sides of the different declivities in a slanting direction.

3959. *The depth of drains must depend upon the nature of the soils, the positions of the land, and a great variety of other more trifling circumstances.* It was formerly the custom to make them three or four feet in depth, but by modern drainers they are rarely made to exceed thirty inches, or a few inches more, the most general depth being from twenty-four to twenty-six inches. As the main drains have more water to convey away, and are generally of greater length than the lateral ones, they should always be cut somewhat deeper; and where the materials of the soils are porous, the greater depth they are cut, the more extensively they act in lowering the wetness of the land to such a degree as that it can be little injurious to the crops that may be produced upon it: when, however, the operator reaches any impervious material in the soil, through which the moisture cannot pass, it will be quite useless to dig the trench to a greater depth. If it be clay, by going a few inches into it, a more safe passage for the moisture may however be secured. It must notwithstanding be invariably attended to, that the depth of the drains be such as that the treading of heavy cattle may not displace, or in any way injure, the materials employed in constructing or filling them. It may be noticed too, where the horses in ploughing tread in the bottom of the furrow, at the depth of four or more inches below the surface, that, if eight or ten more be allowed for the materials with which the drains are filled, when the depth of the trenches are not more than twenty-four inches, there will only be nine or ten inches of earth for the support of the horses when ploughing. Where the earth has been stirred, such a depth must undoubtedly be too little, and in some measure proves that drains of such a depth are not sufficient. By cutting them down to the depth of two feet and a half in the stiffer soils, they will seldom be penetrated to, or have too great a depth; and in the pervious ones a still greater depth is highly useful, and constantly to be practised.

3960. *The practice of cutting the drains as narrow as possible, which has lately been much attended to, is of importance, as it causes a considerable saving of the*

matters employed in filling them up, whether they be wood or straw; but in cases where bricks or stones are employed, this cannot be so much attended to; however, there is seldom a necessity for a greater width than about a foot, provided the stones be coupled at the bottom, or thrown in in a mixed way; nor more than sixteen inches where laid in the manner of a sough or channel. But of whatever depth the materials may be, the earth or mould by which they are covered up should not be less in depth than a foot; in arable lands it should be more.

3961. *The different sorts of drains in use may be classed in two divisions; drains of conveyance (fig. 499 a, b.) alone, and drains of conveyance and collection jointly (fig. 499 c, d).* In the former, all that is necessary is a channel or passage for the water of sufficient dimensions, which may be formed by pipes of different kinds, arched or barrel drains (b), and box or walled drains (a). The construction of the latter requires not only an opening for conveying the water, but a supercumbent or surrounding stratum (e, f) of sufficient porosity to admit and induce all latent water to find its way to the channel of conveyance. The most complete drain of conveyance is a large pipe of metal, masonry, or brick-work; and the most complete collecting drain, one formed with a channel built on the sides, and covered with flat-stones, with a superstratum of round stones or splinters, diminishing to the size of gravel as they rise to the surface, and there covered with the common soil. As the best constructions, however, are not always practicable, the following are a few of the leading sorts adapted for different situations.

3962. *For drains of conveyance, there are the walled or box drain (fig. 499 a), the barrel drain (b), the walled or the triangular drain (c), and arched drain (fig. 500).*

3963. *Drains of collection are formed of stone, brick, gravel, cinders, wood, spray, straw, turf, and earth alone.*

3964. *The boxed and rubble drain (fig. 501.), has been already described as a drain of conveyance and collection.*

The common rubble drain is formed of rough land-stones of any sort not exceeding six or seven inches in diameter, thrown in the bottom, with smaller ones over, and if to be had, gravel or ashes at top. On this is laid a thin layer of straw or haulm of any kind, and the remainder is filled up with the surface soil.

3965. *The brick drain is formed in a great variety of ways, either from common bricks and bats in imitation*

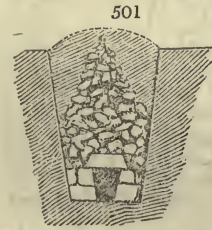

of the boxed and rubble, or rubble drain; or by the use of-bricks made on purpose, of which there are great variety (fig. 502. a to k.) Draining tiles to be used with effect as collecting drains, should always be covered a foot in depth or more with stones or gravel.

3966. *On the Marquess of Stafford's estate, "an allowance of draining tiles is made, wherever the exertions of the tenants seem to merit such a reward. In order to secure the drains being properly filled up with stones above the tiles, the tenant is obliged to drive a sufficient quantity of stones or cinders from the furnaces, and lay them on the ground, previous to an order being made for the delivery of the tiles. Without attending to this important circumstance, much draining would be thrown away. The park at Trentham is a complete illustration of this remark. The draining of this spot was conducted under the direction of Elkington. The wetness with which these lands are affected, does not arise from any line of springs bursting out from the upper grounds, to which that gentleman's system of deep drains could be applied; but is occasioned almost entirely by the retentive nature of the subsoil, and for its being intermixed with small basins of sand, which lie detached and unconnected with each other, in the bed of clay. To cure this species of wetness, a number of small drains, well filled up, with one cut into each of these beds of sand is necessary, in order effectually to cure the evil. In pursuance of this plan, a great part of the park at Trentham has been lately drained over again, by making a number of small shallow drains, about fifteen feet asunder, in some instances above the old ones, taking particular*

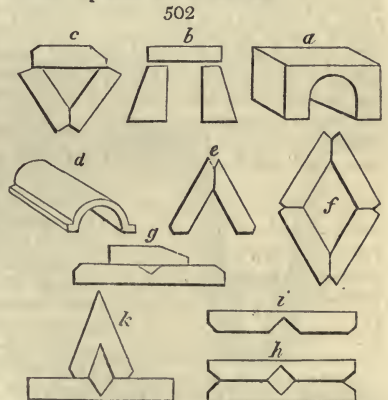
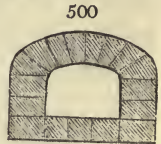
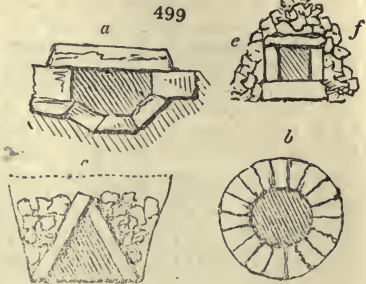

care to fill them up as well as possible, and not to permit any clay to be laid over the stones. This has proved effectual." (*Loch.*)

3967. *The gravel or cinder drain* is seldom made deep, though, if the materials be large, they may be made of any size. In general they are used in grass lands; the section of the drain being an acute angled triangle, and the materials being filled in, the smallest uppermost, nearly to the ground's surface.

3968. *The wood drain* is of various kinds. A very sufficient and durable construction consists of poles or young fir-trees stripped of their branches and laid in the bottom of the drain lengthways. They are then covered with the branches and spray. Another form is that of filling the drain with faggot-wood with some straw over. A variety of this mode (*fig. 503.*), is formed by first setting in cross stakes to prevent the faggots from sinking; but they are of no great use, and often occasion such drains to fail sooner than common faggot drains, by the greater vacuity they leave after the wood is rotten. In some varieties of this drain the brush-wood is first laid down alongside the drain and formed by willow or other ties into an endless cable of ten or twelve inches in diameter and then rolled in, which is said to form an excellent drain with the least quantity of materials, and to last a longer time than any of the modes above mentioned. Some cut the brush-wood into lengths of three or four feet, and place them in a sloping direction with the root end of the branch in the bottom of the drain; others throw in the branches at random with little preparation and cover them with spray, straw, or rushes, and finally the surface soil.



503

3969. *The spray drain* is generally like the gravel drain, of small size, and formed like it, with an acute angled bottom. In general, the spray is trod firmly in; though in some cases it is previously formed into a cable, as in the brush-wood drain. Drains of this sort are much in use in grass lands, and when the spray of larch wood, heath, or ling can be got, they are of great durability.

3970. *The straw drain*, when reeds, rushes, and bean straw is used, is sometimes made like the spray drain, by pressing the loose material down, or forming a cable; but in general the straw is twisted into ropes as big as a man's leg, by the aid of a machine (2457.), and three or more of these (*fig. 504 a*) laid in the bottom of a triangular drain, with or without the protection of three turves (*b*). Where some sorts of moss, as sphagnum or lycopodium can be got, these drains are of unknown durability. Drains formed in this manner, through tough and retentive clays, will be found in a short time after the work is finished, to have formed over the straw with which the drain was filled, an arch of sufficient strength to support the incumbent weight of the soil, and the casual traffick of the field. In twelve or eighteen months it may be observed, that the straw, being of one uniform substance, is all rotted and carried away, leaving a clear pipe through the land in every drain. The passage of the water into these drains may be much facilitated, by a due attention to filling them with the most friable and porous parts of the surface the field may afford.

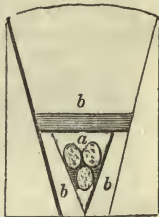

504

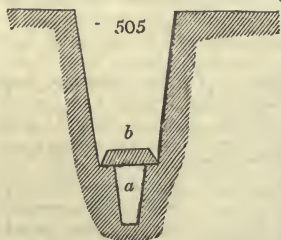

505

3971. *The turf drain* (*fig. 505.*), may be made of any convenient depth, but it must be at least the breadth of a turf at bottom. The drain being dug out as if it were to be filled with stones or any ordinary material, the operator next, with a spade three inches wide, digs a narrow channel along its centre (*a*), clearing it out with the draining scoop; and over this the turves (*b*) are laid without any other preparation, or any thing put over them but the earth that was excavated. This is found to be a very cheap, and, considering the materials, a surprisingly durable method of draining; answering, in pasture-fields especially, all the purposes that the farmer

can expect to derive from drains constructed with more labor, and at a much greater expense. They are said to last frequently twenty years and upwards; but the period which it can be supposed they will continue to prove effectual, must depend on the nature of the soil and the current of water.

3972. *The triangular sod drain* is thus made: when the line of drain is marked out, a sod is cut in the form of a wedge, the grass side being the narrowest, and the sods being from twelve to eighteen inches in length. The drain is then cut to the depth required, but is contracted to a very narrow bottom. The sods are then set in with the grass side downwards, and pressed as far as they will go. As the figure of the drain

does not suffer them to go to the bottom, a cavity is left which serves as a watercourse; and the space above is filled with the earth thrown out.

3973. *The hollow furrow drain* is only used in sheep-pastures. Wherever the water is apt to stagnate, a deep furrow is turned up with a stout plough (fig. 506 a). After this, a man with a spade pares off the loose soil from the inverted sod, and scatters it over the field, or casts it into hollow places. The sod thus pared, and brought to the thickness of about three inches, is restored to its original situation, with the grassy side uppermost, as if no furrow had been made (b). A pipe or opening is thus formed beneath it, two or three inches deep in the bottom of the furrow, which is sufficient to discharge a considerable quantity of surface water, which readily sinks into it. These furrows, indeed, are easily choked up by any pressure, or by the growth of the roots of the grass; but they are also easily restored, and no surface is lost by means of them.

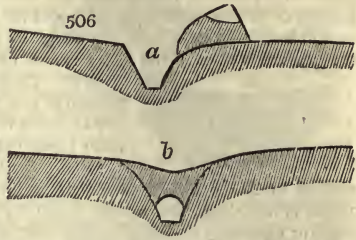

3974. *The earth drain*, called also *the clay pipe drain*, is better calculated for the purpose of an aqueduct, or conveyance of water, than for drying the soil. A drain is dug to the necessary depth, narrow at bottom, in which is laid a smooth tree or cylindrical piece of wood, ten or twelve feet long, six inches in diameter at the one end, and five at the other, having a ring fastened in the thickest end. After strewing a little sand upon the upper side of the tree, the clay or toughest part of the contents of the trench is first thrown in upon it, and then the remainder, which is trod firmly down. By means of the ring and a rope through it, the tree is drawn out to within a foot or two of the small or hinder end, and the same operation repeated. A gentleman who has tried this experiment says, this clay pipe has conducted a small rill of water a considerable way under ground for more than twenty years, without any sign of failing.

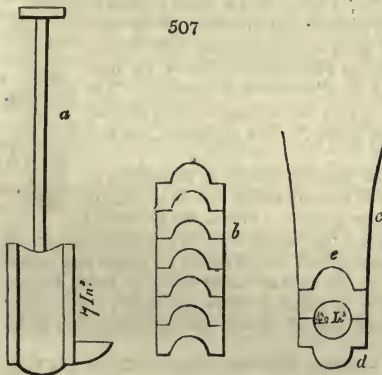

3975. *Pipe drains of turf* are sometimes formed where the surface soil is a strong clay, as it is only turves from such a surface that are sufficiently durable. A semicylindrical spade (fig. 507 a), is used to dig the turves, the ground-plan of which (b) presents a series of semicircles or half pipes. The drain (c), being dug out to the proper depth, one turf is laid in the bottom (d), and another being placed over it (e), completes the pipe. The same sort of pipe drain has been formed out of solid beds of clay, and has served for a time to convey water. As collecting drains, of course, they can be of little or no use. This mode of draining appears to have been first practised by Hannah, an ingenious farmer in Wigtonshire. He adopted it for the purpose of

conveying water through running sand, in which only a pipe drain will last for a moderate time. After a number of years the clay turves were found effective in conveying away the water, and preventing the running away of the sandy sides of the drain.

3976. *A mode of turf draining in use in Cheshire*, is done in the following manner: The surface of the ground where the drain is intended to be cut, is marked out in parallelograms about the size of bricks on one side (fig. 508 a

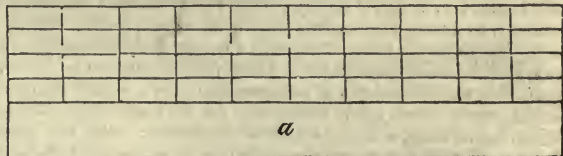

one side (fig. 508 a

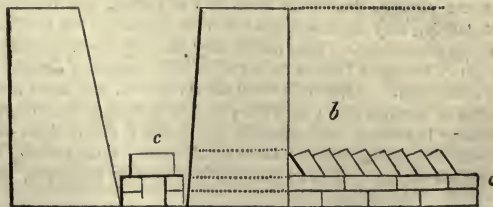

and the opposite is left of the width of a common sod; *i. e.* nine inches wide. These sods are taken out at a spade's depth, and laid carefully by the side of the drain for covers. The sods (*a*), resembling bricks in their size and shape, are then dug, and laid carefully on the same side as the sods intended for covers. The drain is then sunk to its proper depth, and the stuff taken out is thrown to the other side. The bottom is levelled with proper draught for the water, and set with the sods like bricks (*a*), two in height on each side (*c*); these are covered with the larger sods set obliquely (*b*); the grass side of each sod being turned downwards. (*Ag. Rep. of Cheshire*, 214.)



3977. *The mole drain* (*fig. 509.*) is formed by the draining-plough of that name, already described (2522.), with the manner of using it. It is chiefly useful in pasture-lands, and especially in such as have some declivity, or are formed into ridges.

3978. *The wheel drain* is a very ingenious invention, described in *The Agricultural Report of the County of Essex*. It consists of a draining-wheel of cast-iron, that weighs about 4 cwt. It is four feet in diameter; the cutting-edge or extremity of the circumference of the wheel is half an inch thick, and increases in thickness towards the centre. At fifteen inches deep it will cut a drain half an inch wide at the bottom, and four inches wide at the top. The wheel is so placed in a frame, that it may be loaded at pleasure, and made to operate to a greater or less depth, according to the resistance made by the ground. It is used in winter when the soil is soft; and the wheel tracks are either immediately filled with straw ropes, and lightly covered over with earth, or they are left to crack wider and deeper till the ensuing summer; after which the fissures are filled with ropes of straw or of twisted twigs, and lightly covered with the most porous earth that is at hand. Thus, upon grass or ley lands, hollow drains, which answer extremely well, are formed at a trifling expense. It is said, that twelve acres may be fully gone over with this draining-wheel in one day, so as to make cuts at all necessary distances.

3979. *Surface-gutters made by cart-wheels* have been used by Middleton, on meadows in Surrey. To the felly of a common cart-wheel (*fig. 510 a*), is added a piece of wood, the section of which is a truncated triangle (*b*), and on this is fixed a piece of iron completing the triangle (*c*). The cart is loaded and driven so as the prepared wheel may run in the furrow; or, if there are no furrows, both wheels may be prepared, and the loaded cart drawn by two horses, may be led over the whole field, forming parallel gutters, at four or five feet distance. The advantage of this mode of surface draining is, that the herbage is only pressed down, not destroyed, and rises up again in spring. The operation, for that reason, requires to be renewed every winter.



3980. *The best season for marking out and forming drains*, is the spring or beginning of summer; because then, the land springs being still in vigor, are more easily discovered and traced than at a later period. When the ground is soft on the surface, it is a useful precaution, after the line of drain is indicated, to cart on the materials for filling before digging the drain, as the weight of the carriages and horses are apt to press in the sides of the drain. In the case of straw, turf, or earth drains, where the ground is of a firm texture, this precaution does not apply. In filling drains, the earth should always be raised somewhat above the general surface, to make allowance for sinking.

3981. *In forming small drains, chiefly for retentive soils*, the common plough has been used in many places, and with some advantage. The method practised by Young, of Clare, and which he has himself described in *The Annals of Agriculture*, from very ample practice, is this: he says, when he has marked the drains in a field usually a rod asunder, he draws two furrows with a common plough, leaving a baulk betwixt them about fifteen inches wide; then with a strong double-breasted plough, made on purpose, he splits that baulk, and leaves a clean furrow fourteen or fifteen inches below the surface; but where the depth of soil requires it, by a second ploughing he sinks it to eighteen or twenty inches: it is then ready for the land-ditching-spade, with which he digs, fifteen inches deep, a drain as narrow as possible. But the method followed by some farmers, who do not possess ploughs made on purpose for the work, is this: With their common plough, drawn by four or five horses, and usually stirring about four or five inches deep, they turn a double furrow, throwing the earth on each side, and leaving a baulk in the middle. This baulk they raise by a second bout, in the same manner: then they go in the open furrow twice, with their common double-breast plough, getting what depth they can. After this they shovel out all the loose mould and inequalities to the breadth of about a foot; and thus having gained a clear open furrow, the depth varying according to the soil and ploughs, but usually about eight or nine inches, they dig one spit with a draining spade sixteen inches deep, thus gaining in the whole twenty-four or twenty-six inches. But as this depth is seldom sufficient, when necessary they throw

out another, or even two other spits, which makes the whole depth from thirty to forty inches.

3982. *The duration of drains* must necessarily depend on the nature of the materials with which they are filled, and in some measure on the quality of the soil, as certain species of land have the power of preserving wood or other perishable materials much longer than others. Stones last till accidental causes impede the flowing of the water, and may last for ever. Wood perishes in certain periods, but it does not follow that the drains should stop; if the earth arches, the water will necessarily continue to flow, which is found to be the case when wood, straw, and stubble, are rotten and gone. Drains that have been filled with bushes and straw, both which were rotten, have been observed to run well forty years after making.

3983. *The expense of drains* will of course vary with the soil, depth, price of labor, &c., and these circumstances are so different in different districts, and even in different parishes, that it accounts for the various reports of writers on the subject. Those farmers who are most solicitous to have the work well performed, contract with men only for digging and leaving clean, in order that the filling may be done by men paid by the day, as a greater security that it should be executed with all possible care; whatever may be the expense and trouble incurred in draining, it may be safely asserted, that if the work is judiciously contrived, and properly executed, no kind of outlay will prove so beneficial to the cultivator.

3984. *The enemies of drains*, according to Marshal, are moles, field mice, and the roots of trees; the two first may be kept under by traps or other devices; but the last enemy is not easily guarded against but in the laying out of the drain, which should always if possible be kept distant from trees or woody plants of any description.

SECT. VII. *Of the Implements peculiar to Draining.*

3985. *The tools peculiar to draining* are chiefly of the spade kind; there are also boring instruments of different kinds.

3986. *The draining-scoop* (fig. 511 *a, b, c*), is a crooked kind of tool made use of in some cases for clearing out the loose materials from the bottoms of drains. It is formed of different sizes and breadths, according to the drains, and in working is drawn or pushed along the bottom.

3987. *The draining shovel* (*d*), is another sort of implement employed for the same purpose as the above. It is made with a crooked handle, and the edge of the shovel part is turned up, in order to prevent the materials from falling off.

3988. *The draining sod knife* (*e*), is an implement made use of with great benefit in scoring or cutting out the sward in forming drains.

3989. *Draining spades* (*f, g, h*), are made of different breadths, so as to follow each other, and cut the drains narrow at the bottoms. An upper and pointed draining-spade, (*g*) is in general use, and a wooden one (*h*) is employed in peat soils.

3990. *The draining straw-twisting engine*, is a machine of very simple construction, already described (2457.), and capable of being readily removed, contrived for the purpose of twisting straw into ropes, in order to the filling of drains with it.

3991. *The common borer and peat borer* have been already described (2428. 2430.)

3992. *The common draining auger* (fig. 512.), consists of four parts, the shell or wimble, the chisel, the rod, and the handle. The auger shell or wimble (*e*), as it is variously called, for excavating the earth or strata through which it passes, is generally from two and a half to three and a half inches in diameter; the hollow part of it one foot four inches in length, and constructed nearly in the shape of the wimble

used by carpenters, only the sides of the shell come closer to one another. The rods (*a*), are made in separate pieces of four feet long each, that screw into one another to any assignable length, one after another, as the depth of the hole requires. The size above the auger is about an inch square, unless at the joints, where, for the sake of strength, they are a quarter of an inch more. There is also a chisel and punch (*b*), adapted for screwing on in going through hard gravel, or other metallic substances, to accelerate the passage of the auger, which could not otherwise perforate such hard bodies. The punch

511

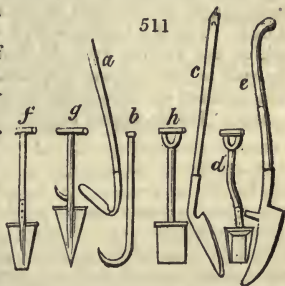

512

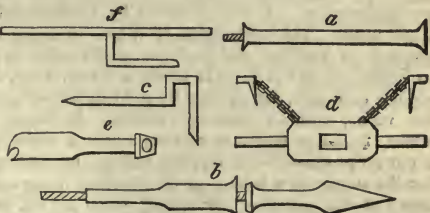

is often used, when the auger is not applied, to prick or open the sand or gravel, and give a more easy issue to the water. The chisel is an inch and a half or two inches broad at the point, and made very sharp for cutting stone; and the punch an inch square, like the other part of the rods, with the point sharpened also. There is a shifting handle of wood (*d*), that is fastened with two iron wedges affixed to it, for the purpose of turning round the rods in boring; and also two iron keys (*f*, *c*), for screwing and unscrewing the rods, and for assisting the handle when the soil is very stiff, and more than two men required to turn it.

3993. *To judge when to make use of the borer is a difficult part of the business of draining.* Some have been led into a mistaken notion, both as to the manner of using it, and purpose for which it is applied. They think, that if by boring indiscriminately through the ground to be drained, water is found near enough the surface to be reached by the depth of the drain, the proper direction for it is along these holes where water has been found, and thus make it the first implement that is used. The contrary is the case, and the auger is never used till after the drain is cut; and then for the purpose of perforating any retentive or impervious stratum, lying between the bottom of the drain and the reservoir or strata containing the spring. Thus does it greatly lessen the trouble and expense that would otherwise be requisite in cutting the trench to that depth to which, in many instances, the level of the outlet will not admit.

3994. *The manner of using it is simply thus:* in working it, two, or rather three men are necessary. Two stand above, one on each side of the drain, who turn it round by means of the wooden handles, and when the auger is full they draw it out; and the man in the bottom of the trench clears out the earth, assists in pulling it out, and directing it into the hole, and he can also assist in turning with the iron handle or key, when the depth and length of rods require additional force to perform the operation. The workmen should be cautious in boring, not to go deeper at a time without drawing, than the exact length of the shell, otherwise the earth, clay, or sand, through which it is boring, after the shell is full, makes it very difficult to pull out. For this purpose the exact length of the shell should be regularly marked on the rods, from the bottom upwards. Two flat boards, with a hole cut into the side of one of them, and laid alongside of one another over the drain in the time of boring, are very useful for directing the rods in going down perpendicularly for keeping them steady in boring, and for the men standing on when performing the operation.

3995. *The horizontal auger (fig. 513.), is another boring instrument employed in*

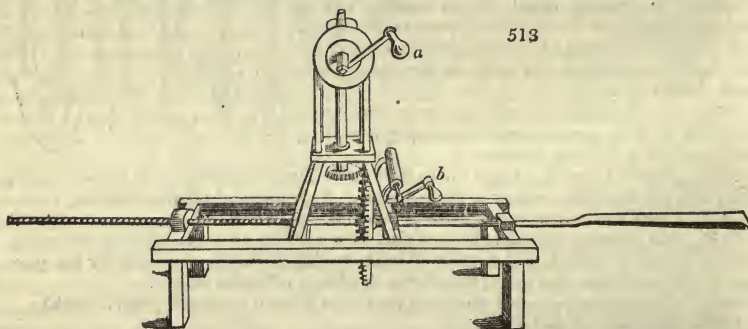

particular cases. It was invented by Halford, of Hathern, in Leicestershire, but is little used. The advantages of it are, in some cases, considerable, by lessening the expense of cutting, and performing the work in a much shorter time. Where a drain or water-course has to pass under a bank, road, hedge, wall, rivulet of water, or for drying marl-pits, &c. it may be used to advantage in excavating a sufficient passage for the water, without opening a trench. In laying leaden pipes for the conveyance of water, it is also useful in making a hole in which the pipe may be laid without opening a cut on purpose. For tapping springs, or finding water at the bottom of a hill, either for the supply of a house, or for draining the ground, it may likewise be used with success; as the water of the spring when hit on, will flow more easily, and in greater abundance through a horizontal or level, than through a perpendicular outlet.

3996. *The manner of using it is this:* suppose a lake or pond of water, surrounded with high banks, to be emptied, if the ground declines lower on the opposite side, find the level of the bank where the perforation is to be made. There smooth the surface of the ground so as to place the frame nearly level with the auger, pointing a little upwards. It requires two men to turn the handles at top (*a*), in order to work it; and when the auger or shell is full, the rods are drawn back by reversing the lower handle (*b*); and



other rods added at the joint when the distance requires them. In boring through a bank of the hardest clay, two men will work through from thirty to forty feet in a day, provided there is no interruption from hard stones, which will require the chisel to be fixed on in place of the shell, and longer time to work through. If the length to be bored through is considerable, or longer than the whole length of the rods, a pit must be sunk upon the line, down to the hole, for placing the frame when removed, and the operation carried on as before.

---

## CHAP. II.

### *Of Embanking and otherwise protecting Lands from the Overflowing or Encroachment of Rivers or the Sea.*

3997. *Lands adjoining rivers or the sea*, are frequently subject to be overflowed, or washed away, or to be injured by the course of rivers being changed during great floods. The subject of this chapter therefore embraces that of embanking and guarding the banks of rivers.

#### SECT. I. *Of Embanking Lands from Rivers or the Sea.*

3998. *The great value of alluvial soil* to the agriculturist, no doubt, gave rise to the invention of banks, or other barriers, to protect soils from the overflowing of their accompanying rivers. The civilized nations of the highest antiquity were chiefly inhabitants of valleys and alluvial plains; the soil, moisture, and warmth of which, by enlarging the parts, and ameliorating the fruits of the vegetable kingdom, afforded to man better nourishment at less labor than could be obtained in hilly districts. The country of Paradise, and around Babylon, was flat, and the soil saponaceous clay, occasionally overflowed by the Euphrates. The inhabited part of Egypt was also entirely of this description. Historians inform us, that embankments were first used by the Babylonians and Egyptians, very little by the Greeks, and a good deal by the Romans, who embanked the Tiber near Rome, and the Po for many stadia from its embouchure. The latter is perhaps one of the most singular cases of embankment in the world.

3999. *The oldest embankment in England* is that of Romney Marsh, as to the origin of which, Dugdale remarks, "there is no testimony left to us from any record or historian." (*History of Embanking and Draining.*) It is conjectured to have been the work of the Romans, as well as the banks on each side of the Thames, for several miles above London, which protect from floods and spring tides, several thousand acres of the richest garden ground in the neighborhood of the metropolis. The commencement of modern embankments in England took place about the middle of the seventeenth century, under Cromwell. In the space of a few years previously to 1651, 425,000 acres of fens, morasses, or overflowed muddy lands, were recovered in Lincolnshire, Cambridgeshire, Hampshire, and Kent; and let at from 2s. 6d. to 30s. an acre. (*Harte's Essays*, p. 54., 2d edit.) Vermuyden, a Fleming by birth, and a colonel of horse under Cromwell, who had served in Germany during the thirty years' war, was the principal undertaker of these works.

4000. *Very little has been written on the subject of embankments*, as a separate branch of art, by British authors. Dugdale's work is entirely historical and topographical. But the writings of Smeaton, Young, Gregory, &c., contain the general principles on which is founded the art of embanking, and every other operation connected with water, and Beatson, in *Communication to Board of Agriculture*. Dr. Anderson, Marshal, and some others, have written on the practice of the art. The works of this sort constructed in our own times will be found described in *The Agricultural Reports* of the maritime counties, especially of Lincolnshire, by Arthur Young. We shall first submit some general remarks on the principles of designing embankments, and next describe the principal kinds of banks with their application.

#### SUBJECT. 1. *General Principles of designing Embankments.*

4001. *The theory of embanking*, Marshal observes, is beautifully simple. The outward waters having been resisted by a line of embankment, and having receded, those that have collected internally are enabled, by their own weight, to open a valve, which is placed in the foot of the bank, and effect their escape: thus securing the embanked lands from inundation, though beset on every side with water.

4002. *The pressure of still water* against the sides of the vessel containing it; being as its depth, it follows, that a bank of any material whatever, impervious to water, whose section is a right angled triangle, and the height of whose perpendicular side is equal to that of the water it is to dam in, will balance or resist this water, whatever may be the

breadth of the surface of the latter ; and, therefore, that as far as width or extent is concerned, it is just as easy to exclude the Atlantic ocean as a pond or a river of a few yards in width.

4003. *Embankments* may be considered in regard to their situation, direction, construction, and materials.

4004. *The situation of the bank* should be such that its base may not be exposed unnecessarily, to the immediate action of the waves, or the current. And, where the quantity of water is limited, as that of land floods in a particular river may be said to be, the more room it has left to spread in, the less height and strength the bank will require ; and the power of the current will be proportionably lessened. It is to be recollected, however, in all cases where the channel of the water is liable to be warped or filled up, by sulliage, that the narrower the space is, in which the water is confined, the stronger will be its current, and the less silt will, in ordinary cases, be deposited.

4005. *The direction of embankment* should be free from sharp angles, so as to occasion the least possible resistance to the current, whether of a land-flood, or the tide.

4006. *In the construction or form of the bank* there are certain principles to be observed. Its height and strength ought ever to be proportioned to the depth and weight of water which it will have to sustain : and, to increase its firmness, the inner face should lean towards it, as a buttress. But it is on the construction of the outer face, its strength, firmness, and durability principally depend. This ought to be made sloping, to a degree of flatness ; for the twofold purpose of preventing resistance, and taking off the weight of water. In difficult cases, the outer surface may form an angle with a perpendicular line of 45 to 60 degrees, according to the force to be guarded against, and the materials to be employed.

4007. *The materials of the body of the bank* (as well as of the inner face), where the foundation is sound and firm, and the bank can be carried up, at a proper season, without great molestation from the water, may generally be the natural soil of the lands to be embanked. And, where merely the weight of stagnant or slowly moving water is to be guarded against, the outer slope may be of the same material. But where force, whether of waves or a strong current, will act immediately upon the bank, its outer face ought to be made proof against it ; and its base to be particularly guarded, to prevent its being undermined ; the most mischievous and irreparable disaster of embankments. Hence, when the foundation is not sufficiently firm, piles, timber, and masonry may be required, to insure success. And no man ought to begin a work of this nature, without attentively guarding it against every probability of miscarriage.

4008. *A system of drains and floodgates* is requisite for the purpose of freeing the embanked lands from internal waters.

4009. *In designing and setting out the main drain, or discharging channel, on the outside of the embankment*, there are points which require particular attention. The situation of the outfall, or mouth, with respect to the current of the water into which it opens, is of considerable importance. It ought to be such, that the current of the receiving water will not warp up the channel of the drain ; but such, on the contrary, as will tend to clear the mouth and keep the channel free. If it were not to preserve the requisite character of an elementary work, it might be deemed unnecessary to add, that the mouth of the discharging drain should be situated as low as given circumstances and a prudent expenditure will allow, beneath the floodgate of the embankment ; in order that, by inducing a sufficient current, the floodgate, as well as the mouth of the channel, may become free from obstructions. Against the open sea, or a wide estuary, where there is no disgorging channel, but where the waves reach the foot of the embankment, two floodgates may be required ; one on the outer side to sustain the force of the waves, and prevent their blowing up the inner works ; the other within to secure the passage the more effectually. The outer gate in this case is liable to be lifted with the agitation of the waves, and thereby to admit much water ; but the inner valve being in a still undisturbed situation effectually stops its progress.

4010. *Where the discharge is made immediately behind a shifting beach*, and especially where the floodgate is necessarily placed level with or beneath the general surface of the gravel bank, through which the waters have been wont to force a channel, the valve is liable to be buried, and the channel to be closed up by every spring tide, and by every gale of wind which sets in upon it ; and cannot be kept free but by unceasing labor and expense. In an obstinate case of this kind on Lord Cawdor's estate, in Pembrokeshire, the discharging floodgate is defended by a covered channel, carried out through the line or ridge of beach into the sea ; being made strong enough to sustain the weight of the heaviest breakers. This, it is true, has been effected at a great expense, but nevertheless the improvement being of considerable magnitude, with great profit : and in every case, where an external valve is required, and where it is liable to be silted up, or loaded with sand or gravel, great attention to the outward channel, or some defence is necessary. For the floodgate, when loaded, cuts off all communication between the pent up waters and the

materials that impound them. They cannot, by loosening the obstructing matter, as nature would otherwise direct them, force their way through it; nor by surmounting it, can they wear down a channel, and thus set themselves at liberty.

4011. *In ordinary cases*, the outer floodgate may be guarded by a pile fence or jetty, run out from the foot of the embankment, across the known drift of the beach; and in such a manner as not to interrupt the outfall channel of the water; the gravel, &c. which such a safeguard may accumulate, being removed from time to time as occasion may require.

4012. *The best construction of the floodgate* for the uses now under consideration is the common valve, hinging at the top, swinging outward and falling into a rabbeted frame. In forming and hanging a floodgate of this construction, there are a few particulars worthy of attention. It should be made of seasoned wood, and ought to be double; the boards or planks of which it is formed being made to cross each other, to prevent its casting. It should fall truly, and fit neatly within a surrounding rabbet (to lessen the power of the waves to lift it); but not so closely or tight as to stick when swelled by moisture. To prevent this, as well as to give it additional tightness, its edges should not be square, but should bevel somewhat inward in the manner of a bung; the rabbet in the frame being made to answer it. In fixing the frame, it ought to be suffered to lean or batter inward; in which position the door will shut closer, and be less liable to the action of the waves in an exposed situation than it would if it were hung perpendicularly. It ought not, however, to lie so flat or heavy as to prevent the free escape of the internal waters.

4013. *The internal waters* which rise within or fall upon the area of the embanked lands, are to be collected by a main drain, continued upward from the floodgate; and furnished with branches to spread over every part of the field of improvement, so as to draw the water as it collects, from every dip and hollow place, and thus free the surface effectually from stagnant water; saving such only as may be wanted for the use of pasturing stock.

4014. *If alien waters* have a natural and accustomed channel through the embanked area, it may be found necessary to raise a suitable bank at a proper distance on each side of the stream; in order to prevent its overflowing the area in times of floods. Where it is found that an outlet cannot be had low enough to free the area entirely from surface water, it is requisite (though no alien waters intrude) to form an embanked channel or reservoir; to gain the required outfall, and to throw the waters which lodge on the lower grounds into this receptacle; by a draining mill, of which there are a great variety of constructions.

4015. *An embanked channel*, if the banks are raised high enough, or are placed wide enough asunder, so as to contain a sufficient body of water, may have a further use; which, in some cases, may be of the highest importance to an improvement of this nature. For, by the help of folding floodgates, such as are commonly seen in use for the locks of navigable canals placed at the lower end of this canal or reservoir, a body of water may be collected and rapidly discharged; by which easy means, not only the channel of the outer drain, but its mouth, if judiciously contracted, may, from time to time, be cleared from obstructions. Where alien waters of a good quality pass through the field of improvement, an embanked channel may be profitably applied in watering the lands; and where alien waters, which have not a natural or fortuitous passage through it can be commanded, and conducted to it at a moderate expense, they may prove highly beneficial, for either or both of these purposes.

#### SUBJECT. 2. *Of the different Descriptions of Banks in general Use for excluding Waters.*

4016. *Mounds or banks for excluding rivers or the sea* are generally formed of earth, but sometimes also of masonry and even of wood.

4017. *The earthen wall* (fig. 514.) is the simplest description of embankment, and is frequently erected by temporary occupiers of lands on the general principle of enclosing and subdividing, which is sometimes made a condition of tenure between the landlord and tenant. This wall applies to lands occasionally, but rarely overflowed or inundated; and is set out in a direction generally parallel to the river or shore. Its base is commenced on the surface from two to five feet wide, regularly built of turf on the outsides, with the grassy sides underneath. The middle of the wall is filled up with loose earth. The wall is carried up with the sides bevelled towards the centre, so as to finish in a width of one foot or eighteen inches at five or six feet in height. Collateral to such walls, and at the distance of three or four feet, a small open drain is formed, as well to collect the surface water of the grounds within, as that which, in time



514

of turf on the outsides, with the grassy sides underneath. The middle of the wall is filled up with loose earth. The wall is carried up with the sides bevelled towards the centre, so as to finish in a width of one foot or eighteen inches at five or six feet in height. Collateral to such walls, and at the distance of three or four feet, a small open drain is formed, as well to collect the surface water of the grounds within, as that which, in time

of floods, will necessarily ooze through a wall of this construction. The water so collected is let through the wall by tubes, or tunnels of boards (fig. 515.), with a valve opening outwards on their exterior extremity. When the flow of water from without approaches, it shuts the valve, which remains in this state till the flood subsides, when the height of the water within being greater than that without, it presses open the valve and escapes. Walls and valves of this kind are common enough in the drier parts of the fenny districts of Lincolnshire and Cambridgeshire.

515

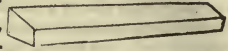

4018. *The earthen mound* (fig. 516.) is the most general description of embankment, and as it is executed at considerable expense, is only undertaken by such as have a permanent interest in the soil. This barrier applies to sea lands overflowed by every spring tide, and to alluvial plains inundated by every flood. It is set out in a direction parallel to the shore, and to the general turns of the river, but not to its minute windings; and it is placed farther from or nearer to the latter, according to the quantity of water in time of floods, the rapidity of the current from the declivity of the bed, the straight course of the stream, and the intended height of the bank. The two sides of such a mound are generally formed in different slopes. That towards the land is always the most abrupt, but can never be secure if more so than  $45^\circ$ ; that towards the water varies from  $45^\circ$  to  $15^\circ$ ; the power of the bank to resist the weight of the water, as well as to break its force when in motion, being inversely as its steepness. The power of water to lessen the gravity of bodies, or in other words, to loosen the surfaces over which they flow or stand, is also lessened in a ratio somewhat similar.

516

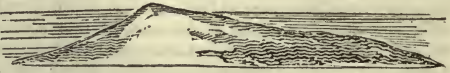

4019. *The formation of the earthen mound* consists merely in taking earth from the general surface of the ground to be protected, or from a collateral excavation, distant at least the width of the mound from its base line, and heaping it up in the desired form. The surface is then in general cases covered with turf, well rolled in order to bind it to the loose earth. The earth of such mounds is generally wheeled by barrows; but sometimes it is led by carts placed on a wooden roller instead of wheels, which, with the treading of the horses, serves in some degree to consolidate the bank.

4020. *The excavation* serves the same purposes as the open drain in the earthen wall; and similarly constructed sluices or valves are introduced on a larger scale. Sometimes also the interior water is drawn off by windmills, and thrown over the mound into the river. This is very common in Huntingdonshire, and might be greatly improved on by employing steam-engines for entire districts, one of which, of a ten horse power, would do the work of twenty mills, and this in calm weather, when the latter cannot move.

4021. *Embankments of this description are the most universal of any*, and their sections vary from a scalene triangle of ten feet in base, and three feet in height, as on the Forth near Stirling, and the Thames at Fulham, to a base of 100 feet, and a height of ten feet, as in the great bank of the Ouse, near Wisbeach. The great rivers of Germany and Holland are embanked in this way, when so far from the sea as to be out of the reach of the tide; as the Vistula at Marienwerder, the banks of which, near Dantzic, are above fifteen feet in height; the Oder, the Elbe, &c. All these banks are closely covered in every part with a grassy surface, and sometimes ornamented with rows of trees.

4022. *But near the sea, where such banks are washed by every tide* when the course of the wind is towards the shore, and by all land-floods and spring-tides, grass is only to be found on and near their summits. The rest of the bank is bare, and to preserve it from the action of waves, currents, and the stones, pieces of wood, and other foreign matters which they carry with them, the surface is covered with gravel, reeds, or straw, kept down by pieces of wood; faggots, wicker hurdles, nets of straw ropes, straw ropes laid side by side and fastened, or handfull of straw fixed in the ground with a dibber (*Neale's Travels in Germany, &c.* chap. i.), or any other contrivance, according to the situation, to prevent the washing away of the bank. It is common to attribute to these coverings the power of breaking the force of the waves; but this power depends, as we have already stated, on the slope of the bank and its smoothness; and the use of the surface covering, and of the constant attention required to remove all obstacles which may be left on it by floods and tides, is to prevent the loosening power of the water from wearing it into holes. For this purpose, a sheet of canvass or straw-netting is as good, whilst it lasts, as a covering of plate iron or stone pavement.

4023. *All banks whatever require to be constantly watched in time of floods or spring-tides*, in order to remove every object, excepting sand or mud, which may be left by the water. Such objects, put in motion by the water, in a short time wear out large holes. These holes, presenting abrupt points to the stream, act as obstructions, soon become much larger, and if not immediately filled up, turfed over, and the turfs pinned down, or the new turfs rendered by some other means not easily softened and raised up by the

water, will end in a breach of the bank. A similar effect is produced by a surface formed of unequal degrees of hardness and durability. The banks of this description in Holland, at Cuxhaven, and along the coast of Lincolnshire, are regularly watched throughout the year; the surface protection is repaired whenever it goes out of repair; as is the body of the bank in the summer season.

4024. *The mound with puddle wall (fig. 517.)* It generally happens that the earth of such banks is alluvial, and their foundation of the same description; but there are some cases where the basis is sand, silt, or gravel; or a mud or black earth, as in some parts of Cambridgeshire and Lincolnshire, which does not easily become so compact. Here it is common, before beginning

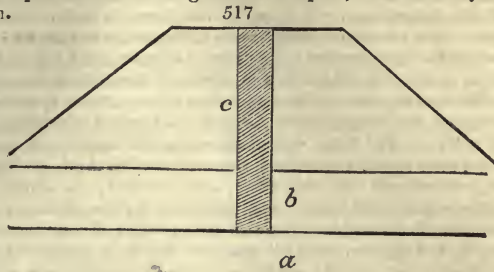

the bank, to bring up what is called a puddle-ditch, or section of clay (*a*), in the centre of the highest part of the mound in the direction of its length, and of three or five feet wide, according to the depth of the stratum of silt (*b*), and the intended height of the bank (*c*). When the clay of this puddle-ditch is well worked, either by men's feet or clay rammers, the bank will be perfectly impervious to water, and if against a mild stream or shore, need not contain such an accumulation of earth as where the imperviousness of the bank to water depends chiefly on the mass of materials. As already observed, the important point to attend to in this variety of mound is, to found the section, or wall of clay, so deep as to be in contact with a stratum (*a*) either by induration; or its argillaceous nature, impervious to water.

4025. *Mounds with reversed slopes.* In some cases of embanking rivers, as where they pass through parks, it is desirable to conceal, as much as possible, the appearance of a bank from the protected grounds. Hence the mound is simply reversed, the steepest side being placed next the water. It is proper to observe, that such banks are not so strong, by the difference of the weight of the triangle of water which would rest on the prolonged slope, were it placed next the river, and are more liable to be deranged in surface in proportion to the difference of the slopes, the water acting for a longer period on every part of the slope.

4026. *Mound faced with stones.* This is the same species of mound, with a slope next the water of forty-five or fifty degrees, paved or causewayed with stones or timber. In Holland this pavement or causeway is often formed of planking or bricks; but in England generally with stones, and the mortar used is either some cement which will set under water, or, what is better, plants of moss firmly rammed between them. The objection to such banks are their expense, and their liability to be undermined invisibly by the admission of the water through crevices, &c. They are, therefore, chiefly used where there is little room, or where it is desirable to narrow and deepen the course of a river.

4027. *Mound protected by a wicker hedge.* This is a Dutch practice, and, where appearance is no object, has the advantage of not requiring watching. Wicker-work, however, subjected to the strain of waves, will be obviously less durable, than where it lies flat on the ground, and can only decay chemically. This wicker hedge is sometimes a series of hurdles supported by posts and studs; but generally in Britain it is a dead hedge or row of stakes, wattled or wrought with bushes presenting their spray to the sea or river. Besides placing such a hedge before a bank, others are sometimes placed in parallel rows on its surface; the object of which is to entrap sand, shells, and sea weeds, to increase the mass of mound, or to collect shells for the purpose of carrying away as manure.

4028. *The sea wall (fig. 518.)* is an embankment formed to protect abrupt and earthy shores or banks of rivers, and consists of a wall, varying in thickness, and in the inclination of its surface, according to the required height, and other circumstances. Belidor, in his *Traité de Hydraulique*, has given the exact curve which the section of such a wall ought to have (*a, b*), in order to resist loose earth, and which is somewhat greater than where the earth behind the wall is supposed to be chiefly firm. Some fine examples of such walls, for other purposes, occur in the CALEDONIAN CANAL, and perhaps the finest in the world are the granite walls which embank the Neva at Petersburg, the construction of which may serve as an example of a river cased with stone on a foundation of soft bog earth.

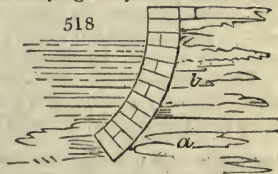

4029. *Embankments for fixing drifting-sands, shells, or mud.* In several tracts of coast, the sea at ordinary tides barely covers a surface of sand; and these sands in dry weather, during high winds, are drifted and blown about in all directions. Great part of the north shores of the Solway Frith, of Lancaster Bay, and of the coast of Norfolk, is of this description. Young, in his *Farmer's Letters*, informs us, that a considerable part of the county of Norfolk was drift sand, even as far inland as Brandon in Suffolk, before the introduction of the turnip culture; and Harte (*Essay I.*) states that some of what is now the richest land in Holland, was, about the middle of the sixteenth century, of this description. The suggestion of any mode, therefore, by which, at a moderate expense, such tracts could be fixed, and covered with vegetation, must be deemed worthy of notice. The mode which nature herself employs is as follows: After the tides and wind have raised a marginal steep of land as high as high water-mark, it becomes by degrees covered with vegetation, and chiefly by the *elymus arenarius*, *triticum junceum*, various species of *juncus*, and sometimes by the *gallium verum*. With the exception of the first of these plants (the leaves and stalks of which are manufactured into mats and ropes in Anglesea, and the grain of which is sometimes ground and used as meal in Ireland), they are of no other use than fixing the sands, which, being composed in great part of the debris of shells, expand as they decay, and contribute to raising the surface still higher, when the fibrous roots of good grasses soon destroy the others.

4030. *To assist nature in fixing drift-sands*, it is only necessary to transplant the *elymus*, which is to be had in abundance in almost every sandy coast in Britain; and as it would be liable to be blown away with the sands, if merely inserted in the common way, it seems advisable to tie the plants to the upper ends of *willow* or *elder* rods, of two or three feet in length, and to insert these in the sand, by which means there is the double chance of the grass growing, and the truncheon taking root. The elder will grow exposed to the sea breeze, and no plant throws out so many and such vigorous roots in proportion to its shoots.

4031. *The mode by which such sands were fixed in Holland* was by the formation of wicker-work embankments, and by sticking in the sands branches of trees, bushes, furze, &c. in all directions. These obstructed the motion of the sands, and collected masses of sand, shells or mud, and sea-weeds around them, which were immediately planted with some description of creeping grass; or, what was more frequent, covered with a thin coating of clay, or alluvial earth, and sown with clover. Though the most certain and least expensive mode of gaining such lands be undoubtedly that of seconding the efforts of nature, by inserting bushes, and planting the *elymus* in this way; yet it may sometimes be desirable to make a grand effort to protect an extensive surface, by forming a bank of branches, which might, in a single or several tides, be filled with sand and shells. It is evident, that such a bank might be constructed in various ways; but that which would be most certain of remaining firm, and effecting the purpose, would be one regularly constructed of framed timber, the section of which would resemble a trussed roof; each truss being joined in the direction of the bank by rafters, and the whole inside and surface stuck full of branches. To retain it firm, piles would require to be driven into the sand, to the upper parts of which would be attached the trusses. The height of such a barrier would require to be several feet above that of the highest spring-tides; and the more its width at base exceeded the proportion of that of an equilateral triangle the better.

4032. *A mode suited to a less extensive scale of operation*, is to intersect a sandy shore in all directions, with common dead, or wicker-work hedges, formed by first driving a row of stakes six or eight feet into the ground, leaving their tops three or four feet above it, and then weaving among these stakes, branches of trees, or the tops of hedges. The Dutch are said to weave straw ropes in this way, and thereby to collect mud in the manner of *warping*. This mode being little expensive seems to deserve a trial in favorable situations; and, in so doing, it must not be forgotten, that much depends on the immediate management of the surface, after it is in some degree fixed. In an extensive trial of this sort at present in progress on the west coast of Scotland, under an English gentleman, seeds and roots are baked in a mixture of loam and dung in the gravel, and then formed into masses, and scattered over a sandy surface. These, from their weight, will not, it is thought, be moved by the water or the wind; but becoming more or less covered with sand, the mass will be kept moist, and the seeds and roots will grow, and, fixing themselves in the soil, will in time cover the surface with verdure. The experiment is ingenious, and we hope will be crowned with success.

## SECT. II. *Of guarding the Banks, and otherwise improving the Course of Rivers and Streams.*

4033. The subject of *guarding the banks of rivers*, is of considerable interest to the proprietors of lands situated in hilly districts, where, in the valleys and on the hill sides, the streams often produce ravages on the banks, and sometimes change their courses.

4034. The natural *licence of rivers*, Marshal observes, is not only destructive of

landed property, frequently of lands of the first quality; but is often the cause of disputes, and not unfrequently of legal contentions, between neighboring proprietors. A river is the most unfortunate boundary line of an estate. Even as a fence, unless where the water is unfordable, a river, or rapid brook, which is liable to high floods, is the most tormenting and inefficient. Proprietors have therefore a double interest in accommodating each other, as circumstances may require, with the lands of river banks, so as to be able to fix permanent boundary lines between their properties. When the owners of estates cannot, by reason of entails or settlements, or will not for less cogent reasons accommodate each other, they have a line to tread which they cannot deviate from with prudence, much less with rectitude; namely, that of cautiously guarding their own lands, without injuring those of their neighbors; for a lawsuit may cost ten times the value of the sand banks, and islets of gravel, to be gained by dexterity of management.

4035. *The operations for improving rivers* have for their object that of preventing them from injuring their banks, accelerating their motion, and lessening the space of ground which they occupy, or altering their site. These purposes are effected by piers or guerdes for altering the direction of the current; works for protecting the banks; and by changing or deepening the river's course.

4036. *The principles on which these operations are founded* are chiefly two; first, that water like every other body when it impinges on any surface, is reflected from it at a similar angle to that at which it approached it; and, secondly, that the current of water, other circumstances alike, is as the slope of the surface on which it runs. On the first of these principles is founded the application of piers for reflecting currents; and on the second, that of straightening rivers, by which more slope is obtained in a given length of stream, and of course greater rapidity of motion obtained.

SUBSECT. 1. *On guarding River Banks.*

4037. *A common cause of injury to the banks of rivers* is produced during floods. A tree or branch carried down by a stream, and deposited, or accidentally fixed or retained in its banks, will repel that part of the stream which strikes against it, and the impulse (contracted more or less by the general current) will direct a substream against the opposite bank. The effect of this continual action against one point of the opposite bank is, to wear out a hole or breach; and immediately above this breach it is customary to place a protecting pier to receive the impulse of the substream, and reverberate it to the middle of the general stream. But if this pier is not placed very obliquely to the substream, as well as to the general stream, it will prove injurious to the opposite bank, by directing a subcurrent there as great as the first; and, indeed, it is next to impossible to avoid this; so much so, that Smeaton, in almost every instance in which he was consulted in cases of this sort, recommended removing the obstacle where that could be done, and then throwing loose stones into the breach.

4038. *Injuries by floods*, according to Marshal, are to be remedied in two ways; the one is to sheath the injured banks of the bays (fig. 519 a, b, c), with such materials

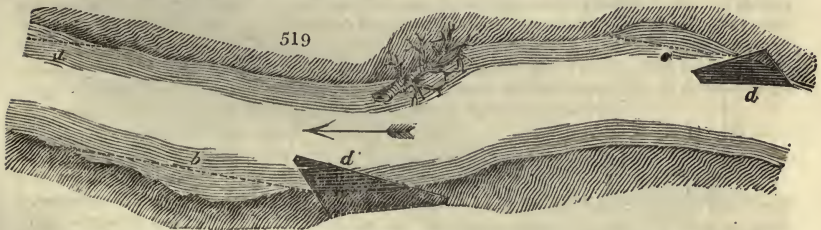

as will resist the circuitous current; and let the river remain in its crooked state. The other, to erect piers (d), to parry off the force of the current from the bank, and direct it forward; with the twofold intention of preventing further mischief, and of bringing back the course of the river to its former state of straightness. It is to be observed, that the operation of guarding the immediate bank of a sharp river bend, against a heavy current meeting with great resistance, by sheathing it with stones, is generally a work of much difficulty and expense, even where materials can be easily procured: while that of diverting the current by a pier may frequently be accomplished at a comparatively small cost; and its effect be rendered infinitely more salutary and permanent. For it is plain, that if the accidental obstruction mentioned, had been timely removed, no bad effect would have ensued: and the river would have continued its direct course. Or if, through neglect, it had been suffered to remain awhile, until its mischief was discoverable; even then, if it had been moved from its station to the opposite side of the river, and placed in the part affected, this small counterpoise might have recovered the balance of the cur-

rent, and directed it into its wonted channel. And in almost any case, by judiciously placing, in a similar manner, a pier or other obstruction proportioned to the magnitude of the power to be counteracted, the like effect may be produced.

4039. *In the use of piers great caution is requisite,* for a very little reflection will show, that they are more likely to increase than to remedy the evil they are intended to cure. We have seen the injurious effects of such piers on the Tay and the Dee; and on a part of the Jed near Crailing they are so numerous, that the stream is, to use a familiar phrase, banded about like a foot-ball, from one shore to the other; behind every pier an eddy is formed, and if the stream does not strike the pier exactly, a breach in the bank takes place. Many of these piers have, in consequence, been taken down. The use of such piers can only be justified where the obstruction, from ill-neighborhood or some such cause, cannot be removed from the opposite bank; or where, as is sometimes the case, it arises from an island of sand or gravel thrown out by the river near its middle, and which, however absurd it may appear, the interested parties cannot agree as to who may remove it. The case of buildings also being in danger, may justify such a pier for immediate protection; but if such breaches are taken in time, a few loads of loose stones dropped in the breach, as recommended by Smeaton, will effect a remedy without the risk of incurring or occasioning a greater evil.

4040. *In the construction of piers,* attention is required to secure the foundation, either by first throwing in a quantity of loose stones, which the water will in a great measure dispose of so as to form a flat surface; or by the use of piles either under, or in single or double rows around those parts of its base in contact with the river. (*fig. 520 a.*) The elevation (*b*), where it is not required to act with great violence on the opposite shore, ought to be bevelled back on all sides exposed to the water, towards the middle of the structure (*c*). In the most important cases stones are the only fit materials, and these

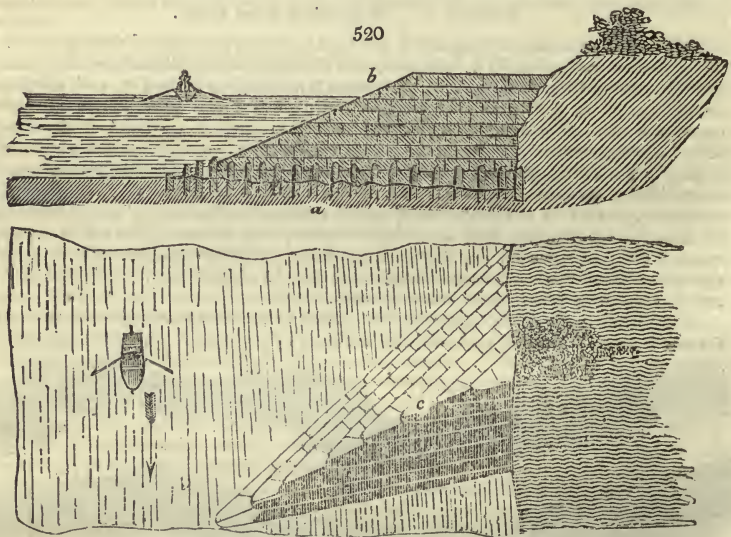

should be regularly jointed and laid in cement according to the best practice of masonry. But, in general, a case of wicker work, of the proper shape, may be filled in with loose stones, some earth, together with the roots of such plants as *tussilago petasites*, *elymus arenarius*, *gallium*, &c. These will form a barrier of considerable durability for some years, and probably till the evil is so far subdued that, when the wicker case decays, its contents will have sufficiently consolidated to effect the object without further care. If not, the wicker case may be renewed. In ordinary cases, a mere wicker hedge projecting into the water will effect the object without further trouble.

4041. *The sheath, or land-guard of loose stones,* which Marshal recommends, and which, in effect, is the mode already mentioned (4037.) as preferred by Smeaton, is applicable to the following cases: First, where the river is confined in the part where it is required to be bent, by rocks or otherwise, to an unaltered channel; as it frequently is, in subalpine situations; and, secondly, where a deep pool occurs, in that part, in low water, so as to render it difficult to get a proper foundation for a pier. Where the foot of the injured bank is covered with a pool at low water, shelve off the brink of the bank, and shoot down loose stones from the top of it; suffering them to form their own slope, in the action of falling, and by the operation of succeeding floods; continuing



to pour them down, until the bank be secured, at least from minor floods, and then slope back the upper part, to give freedom to floods of higher magnitude.

4042. *When the channel of a rapid river is narrow and the banks undermined and washed away by the torrents, what Marshal terms the land-guard is to be used.*

4043. *In forming a land-guard for this purpose, he says, the foundation should be laid pretty deep, to guard against any accidental scoopings from the floods. The wall ought to be carried up dry, or without mortar, the stones being laid with their ends outward, their inner ends pointing to the same centre, like those of an arch, and to be backed with gravel, or earth, rammed in firmly behind, as the facing is carried up. The coping or uppermost course of the stones is to be securely bound, with thick tough sods (8 or 10 inches deep), whose surfaces, when beaten down, ought to lie even with that of the stonework; and similar sods require to be laid, with a gently rising slope, until they unite smoothly with the natural turf of the land to be defended; so that the waters of floods, when they rise above the stonework, may have no abruptness to lay hold of, but may pass away smoothly over the surface of the land, as they commonly do over smooth greensward, without injury. Finally, the stones are to be beaten forcibly into the bank, with a rammer, a mallet, or a small battering-ram, adapted to the purpose; thus rendering the whole compact and firm, to resist the current. Where vacancies or fissures still appear, long splinters of stone are to be driven in, as wedges, to increase the firmness, and prevent the current from tearing out an unguarded stone. It follows, in course, that the largest and longest of the stones ought to be used where the greatest resistance is known to be required.*

4044. *The repairs of a bulwark of this sort, like every other species of river fence, require to be attended to from time to time, especially after great floods. If the foundation be laid bare, it requires to be re-covered with rough gravel, or with stones thrown loosely against it. If any of the facing stones be displaced or loosened, they are to be replaced with others, or to be wedged in afresh. Or, if the turf which binds them at the top be disturbed, the torn part should be cut out square, and be firmly and completely filled up with fresh turves.*

SUBJECT. 2. *Of Changing the Course of Rivers.*

4045. *A river whose course is in a straight line, or nearly so, hardly ever makes any encroachment on its banks, unless perhaps in very large rivers, when they rise above their usual level, either by an increase in their own waters, or their flow being in some degree interrupted by the tides. Hence, whenever a river is narrow in its channel, and winds considerably, any mischief it commonly occasions may be prevented by deepening and straightening the course of the stream. (Code of Agr. p. 319.)*

4046. *The alteration of the course of a river or brook is attended with difficulty and expense, according to the particular circumstances belonging to it. In a simple case, in which one straight cut only is required, the principal difficulty, and that which requires the best skill of the artist, lies in directing the current of the first flood, out of the old into the new channel. But if a bend of the old channel can be made use of, this difficulty may be said to vanish. The mouth of the new cut receives the current with a straight course; consequently, if it be made of sufficient capacity, the river, in a flood, can have no propensity left towards its old channel: and the loose materials which rise in forming the mouth of the new cut, will generally be sufficient to turn the stream at low water into it. But if a suitable bend cannot be approached by the new cut, a directing pier will be required to bend the flood current, and give it a straightforward course into the new channel: a watertight dam being formed between the point of the pier and the firm bank of the new channel to prevent the water from regaining its wonted course.*

4047. *An entirely new bed or channel, however, is much to be preferred where it can be obtained; for in an altered course, when the stream passes alternately through new soil and through a part of its oldbed, its action on surfaces which are so different in regard to induration ends, if great care is not taken, in holes and gulleys in the new bank, which require to be constantly filled up with loose stones thrown in, and left to be fixed by the pressure and motion of the water. In the case of a river passing near a house*

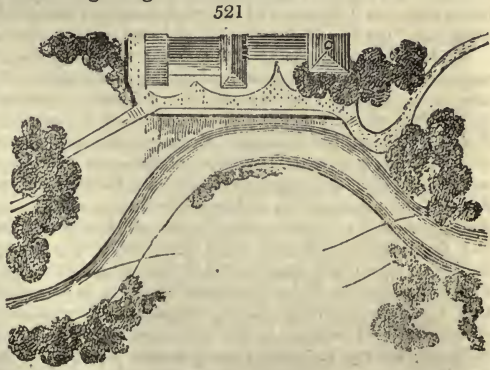

(fig. 521.) this is sometimes of considerable importance.

4048. *Cutting the new channel* is merely a work of manual labor; being attended with no other difficulty than what may arise from the expense, which will depend on the size of the river, the nature of the ground to be cut through, and the value of labor in the given district. It is mostly to be ascertained with sufficient accuracy by previous calculations. (See 3082.)

4049. *The size of the new cut* may be small, compared with that of the old channel. For the current of floods, by carrying off the earthy particles with which they come in contact, will soon enlarge it. It is nevertheless right to give ample room in the new channel, lest the first flood should prove high, and, by bursting its bounds, force its way back to its former course.

4050. *A new river course* requires to be carefully attended to, during a few years after it is opened, — to see that its channel preserves its straightness, and that no breaches are made or threatened in its banks. Considering the uncertainty of extraordinary floods, it cannot be said to be out of danger in less than three years; hence it becomes prudent, when a work of this nature is contracted for, or undertaken to be done by measurement at an estimated price or prices, previously agreed upon (as it generally ought), that the undertaker should agree to preserve the straightness of the channel, and uphold its banks, during that or some other time fixed upon; and to deliver them up at the end of the term, in the state and condition specified in the contract.

4051. A case of *straightening the course of a river* is given in *The Code of Agriculture*. The waters, which in their crooked course were formerly almost stagnated, now run at the ordinary rate of the declivity given them. They never overflow their banks. Cattle can now pasture upon those grounds in which they would formerly have been swamped. The surface of the water being now in general four, and sometimes six feet, below that of the adjacent fields, this cut serves as a general drain to the whole valley; so that three hundred acres of meadow may be converted into arable land; sixty acres of moss may be improved into meadow; and five hundred acres of arable land are rendered of double their former value. (p. 319.)

### CHAP. III.

#### *Of Irrigation or the Improvement of Culturable Lands and Farmeries, by the Means of Water.*

4052. *The improvement of lands by water* is of three kinds: — irrigation, or the application of water to the surface of the soil, and especially of grass lands, as a species of culture; warping, or the covering the soil with water to receive a deposition of earthy matter; and the procuring or preserving of water by wells, reservoirs, and other means, for the use of farmeries, live stock in the fields, or the domestic purposes of the farmer or cottager.

#### SECT. I. *Of Irrigation or the Preparation of the Surface of Lands for the profitable Application of Water.*

4053. *Irrigation* in its different forms may be considered an operation of culture as well as of permanent improvement. It is accordingly in many cases effected by tenants, but always, as in the case of improving wastes, in consequence of extraordinary encouragement from the landlord, by long leases, money advanced, or other advantages.

4054. *The application of water to the surface of lands* for the purpose of promoting vegetation has been practised, as we have seen (180.), from the earliest ages in warm countries. It is an essential article for the culture both of the cereal and pasture grasses, and indeed of most herbaceous crops in all the tropical climates, and even in a great degree in the south of Europe. In the greater part of Italy and Spain, few crops are raised without being irrigated; and even in the south of France, potatoes, maize, madder, and sometimes vines, and orange trees, (as at Hieres,) have water applied to their roots, by furrows and other gutters and trenches formed on the surface. The system of watering grass lands was revived in Italy in the ninth century, and seems to have been practised in a few places in Britain from the time of the Romans; there being meadows near Salisbury which have been irrigated from time immemorial. In 1610, the public attention was called to it by Rowland Vaughan, in a work entitled, “*Most improved and long experienced Water Works; containing the manner of summer and winter drowning of meadow and pasture, by the advantage of the least river, brook, fountain, or water mill adjacent; thereby to make those grounds (especially if they be dry) more fertile ten for one.*”

4055. *But the principal efforts in watering lands* have been made during the latter end of the last, and beginning of the present century, in consequence of a treatise on the subject by George Boswell, published in 1780; and various others by the Rev. Thomas Wright, of Auld, in Northamptonshire, which appeared from 1789 to 1810. The practice, however, has been chiefly confined to England, there being a sort of national prejudice, as Loch has observed (*Improvements on the Stafford Estates, &c.*), against the practice in Scotland, though its beneficial effects may be seen as far north as Sutherland, where rills on the sides of brown heathy mountains, never fail to destroy the heath plants within their reach, which are succeeded by a verdant surface of grasses. A valuable treatise on the subject of irrigation in Scotland, by Dr. Singer, will be found in *The General Report of Scotland*, vol. ii. p. 610. In England the best examples of watering are to be found in Gloucestershire and Wiltshire. In our view of this subject, we shall first consider the soils and situations suitable for irrigation, and next the different modes of effecting it, known as flooding, irrigating, warping, irrigation on arable lands, and subterraneous irrigation.

SUBJECT. 1. *Of the Soils and Situations suitable for the purposes of Watering Lands.*

4056. *The theory of the operation of water on lands* we have already developed. It appears to act as a medium of conveying food, as a stimulus, as a consolidation of mossy soils, as a destroyer of some descriptions of weeds or useless plants, and as the cause of warmth at one season, and of a refreshing coolness at another. From these circumstances, and also from what we observe in nature, there appears to be no soil or situation, nor any climate, in which watering grass-lands may not be of service; since the banks of streams between mountains of every description of rock, and in every temperature from that of Lapland to the equator, are found to produce the richest grass. One circumstance alone seems common to all situations, which is, that the lands must be drained either naturally or by art. The flat surfaces on every brook or river, after being covered with water during floods, are speedily dried when they subside, by the retiring of the waters to their channel.

4057. *The most proper soils for being watered* are all those which are of a sandy or gravelly friable nature, as the improvement is not only immediate, but the effects more powerful than on other descriptions of land. There are also some strong adhesive sour wet lands, such as are common in the vicinity of large rivers, which are also capable of being improved by watering, but the beneficial effects are not in such cases so soon produced as on those of the first sorts, nor is the process so advantageous to the farmer, on account of the very great expense to which he must, in many cases, be put to by previous draining. There are some other lands, as those which contain coarse vegetable productions, as heath, ling, rushes, &c. which may likewise be much improved by watering. It must be kept constantly in mind in attempting this sort of improvement, that the more tenacious the soil is the greater the command of water ought to be for effecting the purpose, as a stream capable of watering fifteen or twenty acres of light dry land, would be beneficial in but a small degree when applied to watering half the same quantity of cold clayey ground such as in their natural state abound with coarse plants. On all soils of the last kind a considerable body of water is requisite for the purpose of floating them in order to produce much benefit, and where that cannot be procured, this mode of improvement will seldom answer the farmer's intention or be advantageous in the result.

4058. *Smith, an experienced irrigator*, supposes that "there are only a few soils to which irrigation may not be advantageously applied: his experience, he says, has determined, that the wettest land may be greatly improved by it, and also that it is equally beneficial to that which is dry." (*Obs. on Irrigation, &c.*) But that as many persons unacquainted with the nature of irrigation may be more inclined to the latter supposition than the former, he explains the reason of wet land being as capable of improvement from flooding as that which is completely dry before. It is that in the construction of all water meadows, particular care must be taken to render them perfectly dry when the business of floating shall terminate; and that the season for floating is in the winter and not the summer, which those who are unacquainted with the process have too generally supposed. All peat bogs are certainly of vegetable origin, and those vegetables are all aquatic. It follows that the same water which has produced the vegetables of the bog would, under due management upon the surface, produce such grasses, or other vegetables, as are usually grown by the farmer; and he has hitherto had reason to think, that this may be considered as a general rule for determining the situation of any experiments with water. The lands that permit of this sort of improvement with the most success are such as lie in low situations on the borders of brooks, streams, or rivers, or in sloping directions on the sides of hills.

4059. *The quality of the water*, like that of marl or other manures, is supposed by some to be a matter of the first importance; but it is now fully proved, by the accurate

experiments of an able chymist, and by the extraordinary growth of grasses in Pristley meadow, in Bedfordshire, that ferruginous waters are friendly to vegetation, when properly applied. (*Smith's Observations on Irrigation*, p. 28.) Lead or copper never does good, and it is well known, that waters of that description, after they have been brought into fields, by levels cut at a considerable expense, have again been diverted, and suffered to flow in their original channels. Waters that are impregnated with the juices that flow from peat-mosses, are considered by many not worth applying to the soil. It is objected to them, that they are soon frozen; that they convey no material nutriment; and that they are commonly loaded with such antiseptic substances, as will retard, instead of promoting vegetation. (*Dr. Singer's Treatise*, p. 579.) It is urged, on the other hand, that a want of sufficient slope in the meadow, or of proper management in regard to the water, may have occasioned the disappointments experienced in some cases, when bog-waters have been applied. (*Derbyshire Report*, vol. ii. p. 463.)

4060. *The advantages of watering lands* must, in a material degree, depend on the climate. It is evident that the benefit to be derived from this process in Sweden for example, where the summers are short, must be greatly inferior to what it is in Lombardy where grass grows all the year; and much less in Perthshire, where grass ceases to grow for at least three, and often four months in the year, than in Gloucestershire or Ireland, where its growth is not interrupted above a month or six weeks, and sometimes not at all: most grasses vegetating in a temperature of 33 or 34 degrees. Still, however, as the most luxuriant pastures are found on lands naturally watered, both in Sweden and Perthshire, it would appear worth while to imitate nature in cold as well as warm countries. According to many writers on the subject, the benefits attending watering in England, are immense. In Davis's *Survey of Wiltshire*, it is calculated that 2000 acres of water meadow will, on a moderate estimate, produce in four or five years, 10,000 tons of manure, and will keep in permanent fertility 400 acres per annum of arable land.

4061. *Watering poor land*, especially if of a gravelly nature, is stated in *The Code of Agriculture* to be by far the easiest, cheapest, and most certain mode of improving it. "Land, when once improved by irrigation, is put in a state of perpetual fertility, without any occasion for manure, or trouble of weeding, or any other material expense. It becomes so productive, as to yield the largest bulk of hay, besides abundance of the very best support for ewes and lambs in the spring, and for cows and other cattle in the autumn of every year. In favorable situations, it produces very early grass in the spring, when it is doubly valuable; and, not only is the land thus rendered fertile, without having any occasion for manure, but it produces food for animals, which is converted into manure, to be used on other lands, thus augmenting, in a compound proportion, that great source of fertility." Were these advantages more generally known, or more fully appreciated, a large proportion of the kingdom might become like South Cerney, in Gloucestershire, where every spring, or rivulet, however insignificant, is made subservient to the purpose of irrigation, fertilizing, in proportion to its size, either a small quantity, or a large tract of land. (*Gloucestershire Report*, p. 280.)

SUBJECT. 2. *Of the Implements made Use of in Watering Lands; and of the Terms of Art peculiar to Works of that kind.*

4062. *The principal instrument* made use of in the preparation of lands for watering, is the level, different descriptions of which have already been given. The level is necessarily employed to take the level of the land at a distance, compared with the part of the river, &c. whence it is intended to take the water, to know whether it can or cannot be made to float the part intended to be watered. It is found very useful in undertakings of this nature, especially when on a large scale, though the workmen too frequently dispense with the use of it, bringing the water after them to work by. In drawing a main they begin at the head, and work deep enough to have the water to follow them; and in drawing a tail drain they begin at the lower end of it, and work upwards to let the water come after them. The level should, however, be made use of as being more certain and correct. Brown, an experienced irrigator in the west of England, recommends a level (*fig. 522 a*), which when not in use may be closed (*b*) like a walking stick. There is also a compass level (*fig. 523.*), which may be used in the same way.

4063. *A line and reel, and a breast-plough, or turf spade* (*fig. 250.*), are likewise absolutely necessary. The use of the two former are well known; but as the line is mostly used in the wet, it should for this purpose be larger and stronger than those employed in gardening. The turf spade should be of the best description, being principally employed in cutting turfs for the sides of the channels.

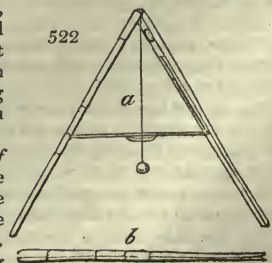

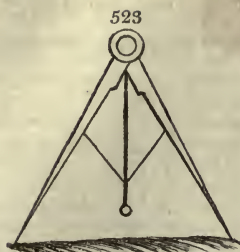

4064. The spades made use of in this sort of work (fig. 524 a), should have the stems considerably more crooked than those of any other sort; the bit being of iron, about a foot wide in the middle, terminating in a point; a thick ridge running perpendicularly down the middle, from the stem almost to the point; the edges on both sides should be drawn very thin, and as they are obliged to be kept very sharp, they should be often ground and whetted. This necessarily wears them away, and they soon become narrow; they are then used for the narrow trenches



and drains, whilst new ones are used for the wider. From the stems being made crooked, the workmen, standing in the working position in the bottom of the trench or drain, are enabled to make them quite smooth and even. Shovels of different forms (fig. 525 a, b), and a scoop for lifting water (c), are also requisite.

4065. The crescent (fig. 524 b) is another tool made like the gardener's edging iron, only much larger, having the form of a crescent, being very thin, and well steeled, with a stem about three feet long, and a cross handle to bear upon. It is used for tracing out the sides of the mains, trenches, drains, &c.



4066. The turf knife (fig. 526.) has a scymer-like blade, with a tread for the foot (a) and a bent handle (b); it is used for the same purpose as the crescent, and by some preferred.

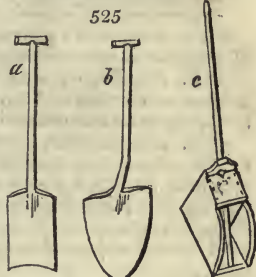

4067. Wheelbarrows also become necessary to remove the clods to flat places; which may be open, without sides or hinder parts.

4068. Handbarrows are likewise sometimes made use of where the ground is too soft to admit of the wheelbarrows, and where clods require to be removed during the time the meadow is in water.

4069. Three-wheel carts, &c. are, however, necessary, when large quantities of earth are to be removed, particularly when it is carried to some distance.

4070. Scythes, of different sorts, (fig. 527 a, b), are required to mow the weeds and grass, when the water is running in the trenches, drains, &c.

4071. Besides these, forks (c), and long four or five tined hicks, are requisite to pull

527

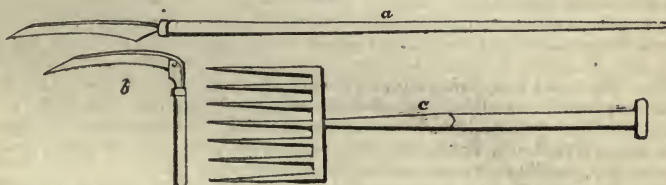

out the roots of the sedge, rushes, reed, &c. which grow in the large mains and drains. The crooks should be made light, and have long stems, to reach wherever the water is so deep that the workmen cannot work in it.

4072. And stout large water-proof boots, having tops so as to draw up half the length of the thigh, are indispensable; they must be large enough to admit a quantity of hay to be stuffed down all round the legs, and be kept well tallowed, to resist the running water for a length of time.

4073. The terms made use of are very different.

4074. A ware is an erection across a river, brook, rivulet, main, &c. made often of timber only, sometimes of bricks, or stones and timber, with from two to eight, or ten thoroughs (openings) to let the water through, according to the breadth of the stream. Its height is always equal to the depth of the stream compared with the adjacent land. Its use is, when the hatches are all in their proper places, to stop the whole current, that the water may rise high enough to overflow the banks, and spread over the adjoining

land; or, by stopping the water in its natural course, turn it through mains, cut to convey it another way, to some distant lands, to water them.

4075. *A sluice* (fig. 528 a, b) is made exactly as a ware, only it has but one thorough; for if there are more than one, it becomes a ware.

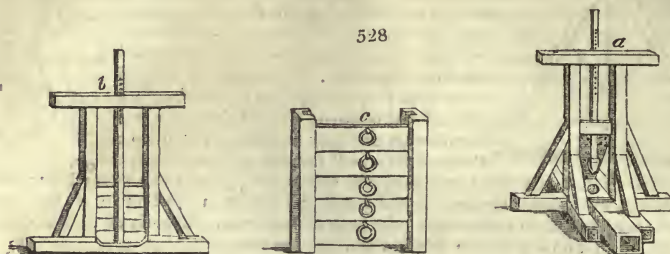

4076. *A trunk* is a covered sluice, being constructed in all cases where two streams of water are to cross each other at the point of discharge, to serve as a bridge.

4077. *A carriage* is a sort of small wooden or brick aqueduct, built open, for the purpose of carrying one stream over another, and is the most expensive conveyance belonging to the business of watering.

4078. *A drain sluice, or drain trunk*, signifies such as are placed in the lowest part of a main, as near to the head as a drain can be formed, and situated low enough to drain the main, &c. It is placed with the mouth at the bottom of the main, being let down into the bank; and from its other end a drain is cut to communicate with some trench-drain that is nearest. It is a contrivance used to carry off the leakage through the hatches when they are shut down, to convey the water to other grounds, or to repair the main, &c.

4079. *Hatches*, (fig. 528 c) are floodgates, variously constructed. A particular kind, which have about a foot, to take off, so as to permit the water to flow over that much of the hatch where it appears to be useful in irrigation has been in use, but is not found to answer. They are best when made whole; they may be made of any timber, but oak and elm are the best.

4080. The term *head main* is used to signify a ditch drawn from the river, rivulet, &c. to convey the water out of its usual current to water the lands laid out for that purpose, through the means of lesser mains and trenches. The head main is drawn of various breadths and depths, according to the quantity of land to be watered; to the length, or to the fall or descent of the land it is cut through. And it often happens that smaller mains are taken out of the head main; the only difference between them is, the one being much less than the other, and are mostly cut at, or nearly at, right angles with the other, though sometimes many degrees less. The use of both the large and small mains is to feed the various trenches with water, which branch out into all parts of the meadow, and convey the water to float the land. These smaller mains are by some called carriages, but improperly, for it is confounding them with the open trunk, called by that name, as seen above.

4081. *The trench* is a narrow shallow ditch, made to take the water out of the mains to float the land with. It ought always to be drawn in a straight line from angle to angle, with as few turnings as possible. It is never made deep, but the width is in proportion to the length it runs, and the breadth of the pane, between that and the trench drain. It is always cut gradually narrower and narrower to the lower end.

4082. *The trench drain* is cut parallel to the trench, and as deep as the tail drain water will admit when necessary. It ought always to be cut, if possible, so as to come down to a firm stratum of sand, gravel, or clay. If the latter, a spade's depth into it will be of great advantage; its use is to carry away the water immediately after it has run over the panes from the trench. It need not be drawn up to the head of the land, by five, six, or more yards, according to the nature of the soil. Its form is the reverse of the trench, being narrower at the head, or upper part, and gradually wider and wider, till it comes to the lower end and empties itself into the tail drain, which is a receptacle for all the water that runs out of the other drains, that are so situated as not to empty themselves into the river; and therefore it should run nearly at right angles with the trenches, but, in general, the preference is given to draw it in the lowest part of the ground, and to use it to convey the water out of the meadow where there is the greatest descent; this is generally found in one of the fence ditches: for which reason a fence ditch is mostly used for that purpose, answering two purposes, fencing the meadow, and draining it at the same time.

4083. *A pane of ground* is that part of the meadow which lies between the trench and the trench drain, and is the part on which the grass grows that is mown for hay; it is wa-

tered by the trenches and drained by the trench drains, consequently there is one on each side of every trench. And a way pane is that part of the ground which lies in a properly watered meadow, on that side of a main where no trenches are taken out, but is watered the whole length of the main over its banks; a drain runs parallel with the main to drain the way pane; its use is for a road to convey the hay upon out of the meadows, instead of the teams crossing all the trenches.

4084. The term *bend* is applied to a stoppage made in various parts of those trenches which have a quick descent, to obstruct the water. It is made by leaving a narrow slip of greensward across the trench, where the bend is intended to be left, cutting occasionally a piece, wedge fashion, out of the middle of it. Its use is to check the water, and force it over the trench into the panes; which, if it were not for those bends, would run rapidly on in the trench, and not flow over the land, as it passes along. The great art of watering meadows consists in giving to every part of each pane an equal quantity of water.

4085. A *gutter* is a small groove cut out from the tails of those trenches, where the panes run longer at one corner than the other. Its use is to carry the water to the extreme point of the pane. Those panes which are intersected by the trench and tail drains meeting in an obtuse angle, want the assistance of these gutters to convey the water to the longest side. Another use of them is, when the land has not been so well levelled but some parts of the panes lie higher than they ought, a gutter is then drawn from the trench over that high ground, which otherwise would not be overflowed. Without this precaution, unless the flats were filled up (which ought always to be done when materials can be had to do it), the water will not rise upon it: and after the watering season is past, those places would appear rusty and brown, whilst a rich verdure would overspread the others; and at hay-time the grass in those places would be scarce high enough for the scythe to touch it, whilst that around them, which has been properly watered, will from its luxuriancy lie down. Though this method of treating those places is mentioned, it ought always to be reprobated; for every inequality in water meadows should either be levelled down or filled up. Here the irrigator's skill is shown, in bringing the water over those places where it could not rise of itself, and in carrying it off from others where it would otherwise stagnate.

4086. The term *catch drain* is sometimes applied to another method made use of to water the land when the water is scarce, and it is this: when a meadow is pretty long and has a quick descent, the water runs swiftly down those drains, one or more of them are, at a proper place, close stopped, till the water flowing thither rises higher and higher, either till it strikes back into the tail drains, so high as to rise upon the sides of the panes (in that case it will not succeed, and must be cut open again to let the water free), or till it flows over the banks of the drain, and waters the ground below; then the design succeeds, and (in proportion to the quantity of water thus collected) it is to be conveyed upon the land, either in a small main, out of which trenches are to be drawn with their proper drains, or by trenches taken immediately out of it. But a catch drain is by no means recommended; and it is proper to remark, that even when this method succeeds, the water having been so lately strained over the ground, it is supposed by the watermen to be not so enriching as it was before it was used, and therefore nothing but absolute necessity can justify its adoption.

4087. *The bed of a river, main, trench, &c.* is the bottom of them.

4088. The term *pond* means water standing upon the land, or in the tail drain, trench drains, &c. so as to injure the ground near them; and is occasioned sometimes by the flats not having been properly filled up; and at other times, when a ware being shut close, to water some high ground above it, the water is thrown back upon the ground contiguous. In this case the lesser evil, whichever it is, must be borne with.

4089. And a *turn of water* means so much land in a meadow as can be watered at one time. It is done by shutting down the hatches in all those wares where the water is intended to be kept out, and opening those that are to let the water through them. The quantity of land to be watered by one turn, must vary with the size of the river, main, &c. as well as with the plenty or scarcity of water.

4090. *The head of a meadow* is that part into which the river, main, &c. first enters; and the tail of a meadow is that part out of which the river, &c. last passes.

4091. *The upper side of a main, or trench,* is that side which (when the main or trench is drawn at, or nearly at, right angles with the river, &c.) fronts the part from whence the river entered. Consequently the lower side is the reverse.

4092. And *the upper pane* in a meadow is that pane which lies upon the upper side of the main, or trench, that is drawn at right angles with the river: that is, when the river, &c. runs north and south, entering at the north, and the mains and trenches are drawn east and west, all those panes, which lie on the north side of the main, &c. are called the upper panes, those on the south side are called the lower. But it may be noticed, that where the mains, trenches, &c. run parallel with the river, the panes on either side are not distinguished from each other.

4093. *Meadows are of two sorts*; flowing, calculated for a flat country; and catch-work, for sloping grounds.

4094. *Flowing meadows.* Where the ground is flat, the soil is formed into beds, or broad ridges, like those met with at bleach-fields. They are commonly from 30 to 40 feet wide, and nine or ten poles in length; as, in such situations, the great object is, when once brought on, to be able to carry off the water quickly. Hence it is necessary to throw up the land in high ridges, with drains between them. More of the failures in irrigation arise, from the ridges not being sufficiently high, and the slopes not being sufficiently steep, than from any other cause. (*Code.*)

4095. *Catch-work meadows.* It is difficult to give an intelligible written description of the mode of making these meadows. To be properly understood, the operation must be seen. It may, however, in general be remarked, that the system is calculated for sloping grounds; and that after the water is brought from the original stream, into a new cut, it is stopped at the end, on as high a level as the case admits of, by which the water is made to fill the trench, and run over at the side, and flood the land below it. But as the water would soon cease to run equally, and would wash the land out in gutters, it has been found necessary to cut small parallel trenches, at the distance of from 20 to 30 feet, to catch the water again (hence the name originated), and the same plan of spreading or diffusing is continued, until the water reaches the main drain at the bottom of the meadow. It is a great advantage attending the catch-work system, that it is not only less expensive, but the same quantity of water will do much more work. (*Code.*)

#### SUBJECT. 3. *Of the Preparation of Surfaces for Irrigation.*

4096. *Artificial irrigation,* Smith observes, is produced by diverting the water of a brook out of its accustomed channel (where there is a fall) in such a manner that the new watercourse being kept nearly level, the space between the old and new channel may be floated; the water being brought upon the land by the new channel and taken away to the old one. Thus a constant discharge and succession of water is retained without such an accumulation as would make it appear bright upon the land, or without such a deficiency as would leave any part of it not perfectly floating, for the art of irrigation may be most properly called floating, not soaking nor drowning. Soaking the soil, similar to the effects produced from a shower of rain, is not sufficient for the general purposes of irrigation, nor will damming up water and keeping it stagnant upon the surface like that in a pond, or on the fens, produce the desired effect.

4097. *Stagnating water on land* may properly be called drowning, because it drowns or covers all the grass, thereby rendering the plants beneath it in some degree aquatic, or the herbage disposed to make such a change; whereas the herbage of a water meadow should, by the construction and good management of the latter, enjoy the full benefits of both the elements of air and water. Practice has proved that there is no better method of doing this, than by keeping water passing over the surface of the land with a brisk current; not so brisk as to wash away the soil, and yet in sufficient quantity to cover and nourish the roots, but not too much to hide the shoots of the grasses: hence appears the nicety of adjusting the quantity of water; and hence it also appears, that one main drain to bring the water on the upper side of the mead, and another on the lower side to take it away, will not be adequate to all the purposes of such an accurate regulation. If the space between the upper channel or main feeder, and the lower one or main drain, should therefore be wider than is proper for the good adjustment of the water, that is, so that every part of the space shall have enough water passing over it and no part too much, then that space must be divided into smaller spaces by intermediate drains, which shall catch and re-distribute the water. As the water is brought by the main feeder upon the higher side of a piece of ground which slopes towards the main drain, and down which sloping surface the water will run very readily, it does not to persons unacquainted with irrigation, at first sight appear necessary to make such a number of intermediate catch drains; but it is proved by experience, that however regular the slope of ground may appear to the eye, that the water will find a number of irregularities, forcing itself into gutters or channels, and defeat the purposes of irrigation; in the hollow places by excess, and in high ones by the want of water. Hence the water, which was scattered over the surface of the first space, being all collected in the catch drain, may by the skill of the floater be let out upon those parts of the bed below which appear to need the most assistance.

4098. *The work should always be well formed at first* in all cases of improvements of this nature. Temporary means of making dams and hatches to divert the water out of its usual channel may, says Smith, "suffice to try an experiment, or for a tenant who has but a short term in the grounds to be irrigated; but every land-owner who enters upon such work in this temporary manner, sadly mistakes his own interest; indeed it is frequently more difficult to repair than to renew upon large streams when the foundations are often destroyed by the force of the water. The same principle holds good upon



small streams, and even in the drains and feeders of a water meadow. Wherever the channels are so constructed as to make a fall, or much increase the rapidity of the stream, it is constantly disposed to wear away the sides of its channel or undermine a dam. To repair these defects, land must be dug away and wasted each time it is replaced with the loss of labor. The consequent ill management of the water renders it more advisable, and perhaps cheaper, to make all such works of masonry. When works are well done at first the owner ever finds much pleasure in viewing them; and even the laborers feel much more interested in their good management.

4099. *The expenses of making a water meadow* are not easily estimated. Much depends on the original state of the ground, the size and fall of the streams to be used, the cost of hatches and length of the main feeders, which may be necessary for diverting the water out of its original channel, and even upon the charge for levelling land, which differs materially. Some soils are much harder and more difficult to move than others, and in certain situations, building materials are very scarce and dear. This last circumstance must make a considerable variation in the price of the hatches, where the stream is large. It is also impossible to tell with any degree of certainty, what proportion these expenses should bear to the quantity of land irrigated, for some situations will require much more masonry than others.

4100. *Before entering upon the execution of a water meadow*, it is necessary to consider fully, whether the stream of water to be made use of will admit of a temporary wear or dam to be formed across it, so as to keep the water up to a proper level for covering the land without flooding or injuring other adjoining grounds; or if the water be in its natural state sufficiently high without a wear or dam; or to be made so by taking it from the stream higher up more towards its source; and by the conductor keeping it up nearly to its level till it comes upon the meadow or other ground. And still further, whether the water can be drawn off the meadow or other ground in as rapid a manner as it is brought on. And having in addition to these an attention to all such other difficulties and obstructions as may present themselves, from the lands being in lease through which it may be necessary to cut or form the mains or grand carriers, from the water being necessary for turning mills, from the rivers or brooks not being wholly at the command of the irrigator, and from small necks of land intervening, so as to prevent the work from being performed to the greatest advantage, the operator may be in a situation to commence his operations.

4101. *In order to have an equal distribution and prevent waste*, Smith states, that no part of a meadow, either in catch-work or beds, should be so formed as to be floated directly from the main feeder; but all the main feeders should be kept high enough to discharge the water into the small feeders with considerable velocity and through a narrow opening. The motion of water is truly mechanical; it requires a great deal of ingenuity, and a perfect knowledge of lines and levels to make it move over the ground in a proper manner. No two pieces of land being exactly alike, renders it still more difficult to set out a water meadow; but even if the figure of two pieces be alike, the inequalities of surface will probably vary. Each meadow, therefore, requires a different design, unless the land owner makes up his mind to the heavy expenses of paring off banks, and filling up such hollows as may be necessary to reduce it to some regular method. The construction to be varied according to the nature of the ground. This constitutes the difference between the water meadows of Berkshire and Devonshire. Those of the latter are upon small streams carried round the sides of the hills, and are chiefly catch-work; those of the former being near large rivers and boggy ground, are thrown up into ridges to create a brisk motion in the water, and also for the essential purpose of draining off all superfluous moisture, which might be injurious to the grasses when shut up for feeding or mowing. Where there is much floating to be done with a little water, or rather where the great fall of a small stream will admit of its being carried over a vast quantity of ground and used several times, it is desirable to employ it in such a way that the meadows so irrigated must not be exhibited as perfect models. If it should answer the purpose of a coat of manure upon such an extent of ground, it is all that can be expected, and will amply repay the expense. Losing fall is wasting water.

4102. *The drains of a water meadow* require no greater declivity than is necessary to carry the water from the surface, therefore the water ought to be collected and used again at every three feet of the fall, if it be not catch-work. It is sometimes difficult to do this in bed-work meads, but where the upper part of the meadow is catch-work or in level beds, and the lower part not too much elevated, it may be done. By collecting and using the water again in the same piece of ground before it falls into the brook, a set of hatches is saved, and it is not necessary to be very particular about getting the upper part into high ridges, since that part of the meadow which is near the hatches generally becomes the best, and the lower end of the field being often the wettest or most boggy in its original state, requires to be thrown up the highest. If the land is of a dry absorbent

nature before floating, it is not necessary that it should be thrown up into high beds, but merely as much inclined as will give the water a current.

4103. *Inclined planes are absolutely necessary for the purpose of irrigation.* To form these between straight and parallel lines, it is necessary to dig away land where it is too high, and move it to those places where it is too low, to make such an uniformity of surface. The new made ground will of course settle in hollows proportioned to the depth of loose matter which has been recently put together, but this settlement will not take place until the new soil has been completely soaked and dried again; therefore these defects cannot be remedied before the second or third year of watering: it will then require more skill to manage a water meadow for the three or four first years, than it can afterwards.

4104. *Properly to construct a water meadow* is much more difficult than is commonly imagined. It is no easy task to give an irregular surface that regular yet various figure which shall be fit for the overflowing of water. It is very necessary for the operator to have just ideas of levels, lines, and angles; a knowledge of superficial forms will not be sufficient; accurate notions of solid geometry (obtained from theory or practice) are absolutely necessary to put such a surface into the form proper for the reception of water without the trouble and expense of doing much of the work twice over. (*Obs. on Irrigation, &c.*)

4105. *As an example of irrigating a meadow from both sides of a river* we take the following case from Boswell's treatise. From the upper part of the grounds, two main drains (fig. 529 *a, a*) are formed at right angles to the river, one running north the other south, across the meadow, to within about six yards of the fence ditches which surround it (*b*), and are used for tail drains: by means of these fence ditches the water is discharged into the river. A wear erected across the river forces the water into either of the main drains, which is done by shutting the other wear close. When there is not water enough, or it is not convenient to water both parts of the meadow at once, by shutting close one of the wears, the current is forced into that main whose wear is open, thence to be conveyed through the trenches over the pans, to water that side of the meadow; then by shutting that, and opening the other, the opposite main is filled, and by means of the trenches that side of the meadow is watered in the same manner; and lastly, by shutting them both, and opening the river wear, the water flows in its usual course, and the land on both sides is laid dry. From the main drains (*a, a*) the water flows along the highest part, or crowns of the ridges in the trenches (*c*), and is carried off to the tail drains by the trench drains (*d*).

4106. *As an example of an irregular surface watered from one side of a river*, we shall have recourse to the same author. There is a wear (fig. 530 *e*) erected across the river,

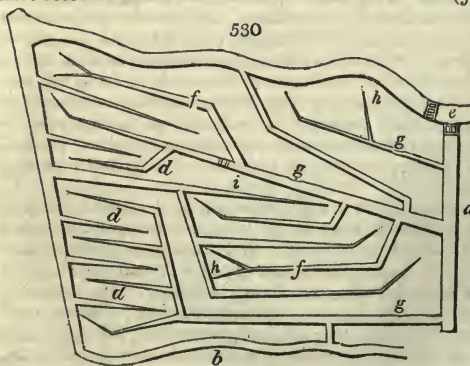

(*f, f*), and various gutters (*h, h*), taken out of the ends of some of the trenches, to carry

529

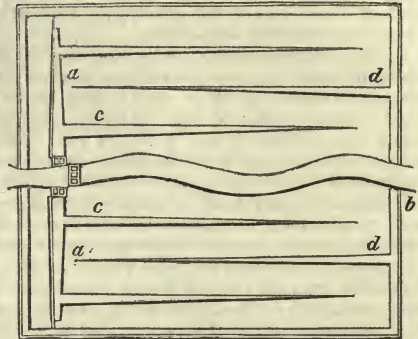

the water to the longest corner of the panes, and sometimes taken out of different parts of the trenches, to water some little irregularities in the panes, which, without such assistance, would not have any water upon them. There is a sluice (*i*) erected at the end of one of the small mains, to force the water into the branch trench adjoining (*f*), that being the highest ground.

4107. *A very complete piece of irrigation (fig. 531.)* was formed for the Duke of Bedford, by Smith, at Pristley.

531

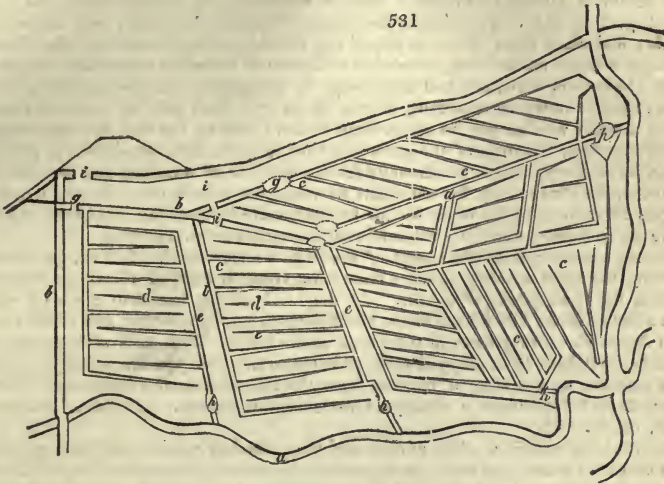

The water is supplied from a brook (*a*), to a main feeder with various ramifications (*b, b'*), the surface is formed into ridges (*c, c*), over which the water flows, and is carried off by the drains in their furrows (*d, d*), to the main drains (*e, e*), and to the brook at different places (*f, f, f*). There are bridges (*g*) over the main feeders, small arches over the main discharging drains (*h*), and three hatches (*i*).

4108. *As an example of catch-work watering, we may refer to a case (fig. 532.), given*

532

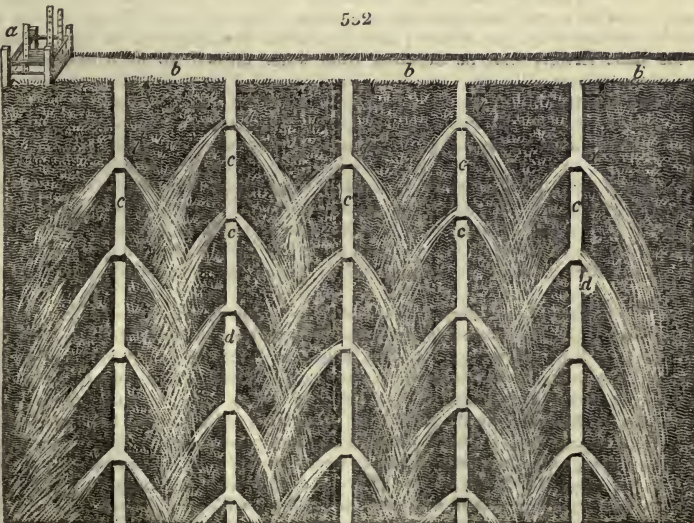

in a recent work by John Brown. (*Treatise on Irrigation, 1817.*) In this the field of operations being on the steep side of a hill, a main carrier is led from the sluice (*a*), directly across the declivity (*b*), and lateral feeders (*c*) taken out from it at regular distances. These feeders have stops of turf, at regular distances (*d*), by which means the water is dispersed. After watering a space of from twenty to forty feet in breadth, it

is again collected by the small drains in the furrows, and returned lower down to another feeder. The advantage of this method, Browne observes, "relates more materially to the sides of hills, and to porous soils that are by some thought incapable of being watered. The chief point is to get the water to the highest level possible; and in case the soil be porous, one main carrier only will require puddling, in order to prevent the water from sinking away: when that is done, no difficulty whatever is found in taking it in small streams vertically, or directly down the slope (c), and putting stops (d) to arrest its progress occasionally, which will throw it on each side; and when those stops are placed one above another, it will have the effect of spreading the water on the land, somewhat similar to a fan when extended. The stops need only be sods or turfs, one laid lengthways in the gutter, and one across it, which may be raised or lowered according to the declivity: these sods or turfs will require probably a small wooden peg to fasten them at first; and by the time the land requires a second watering, the roots of the grass will have sufficiently fastened them; and they need not be removed, unless occasionally for the purpose of watering any separate part below, when the stream may be too small to water the whole piece at once; and the small cuts for conveying the water will be less expensive in cleaning, not being so liable to choke up as those carried on what is termed horizontal or level gutters.

4109. *As an example of the benefit of flooding*, we refer to Loch Ken, in Kircudbrightshire, the most striking instance known in Great Britain of advantage being derived from the inundations of a lake. At the head of that beautiful piece of water, there is a flat of about 240 statute acres, which is rendered, by flooding, one of the richest spots in Scotland. Many acres in it produce at the rate of three tons of hay each, and some parts of it have been cropped with grain for twenty-five years in succession, without any manure, except what it receives from the inundations it experiences. These, however, leave behind them a variety of enriching substances. (*Statistical Account of Scotland*, vol. iv. 260.)

4110. *Floating upwards*. The ancient and now obsolete practice of flooding, or, as it was termed, of floating upwards, was practised in various parts of the kingdom. For that purpose, the water was penned, in times of floods, by means of a dam or floodgate across the bottom of the meadow or flat to be watered. The waters were not suffered to remain long upon the land, but were let off as soon as it was judged that they had deposited their sediment. The benefit arising from this method of using floodwaters, it is said, was considerable; but when the improved mode of irrigation, by floating ridges was introduced, and found more advantageous, the other was discontinued. (*Marshal's Midland Counties*, Minute 27.)

4111. *Watering land by machinery*. If the land be put in a proper form for irrigation, and supplied with a good stream at proper seasons, there can be no difference from the method of getting it on the surface; and if all other circumstances are equally favorable, the same fertility may be expected from water thrown up by a drain-mill, as that which runs from a brook. (*Smith's Observations on Water Meadows*, &c. p. 93.) A cheap and effectual power for raising water in sufficient quantities to flow about ten acres at a time, would be an invaluable acquisition; for a productive water meadow is probably the true mark of perfection, in the management of a farm. (*Middlesex Report*, p. 322.)

4112. *Sea water*. Smith suggests the idea of employing machinery, to raise not only fresh, but even sea water, for irrigation. (*Observations*, p. 87.) It is well known, how much all kinds of stock are improved by salt marshes, and how beneficial to them, is a moderate quantity of saline matter. There are many parts of the kingdom where, by the aid of machinery, these advantages might be obtained at a moderate expense. (*Code*.)

4113. *The expense of irrigation* varies according to the nature of the work. Where the catch-work system is practicable, in favorable situations, the forming may be done as low as ten shillings per acre. This fact is, in many cases, decisively in favor of this natural and simple mode, which requires also much less water, and often answers fully as well as flat flooding. (*General Report*, vol. ii. p. 598.) The expense of bed-work, as it is called; is, however, considerable. If the ground to be flooded, be smooth on its surface, or in regular ridges, and if the water can easily be brought to the meadow, with a temporary wear, supposing the extent to be almost twenty acres, it may be done at 5*l.* to 10*l.* per acre; but if the land be of large extent, with an irregular surface; if a large conductor, and a proper wear shall be required, with hatches both in it, and also in the feeders; and if the aid of a professional person, to lay out and oversee the work, be necessary, (which is generally the case), the expense will vary from 10*l.* to 20*l.* per acre. (*General Report*, vol. ii. p. 598.) Nay, in Wiltshire, where they are anxious to have their meadows formed in the most perfect manner, with that regularity which the nice adjustment of water demands, the expense per acre has amounted to 40*l.* (*Smith's Observations on Irrigation*, p. 56.)

4114. *Objections to irrigation* have been made on the supposition that it renders a country unhealthy; but as the water is continually kept in motion, this is not likely to be the case, and indeed is found not to be so in Gloucestershire, Lombardy, and other countries where it is extensively practised. Others think that though the produce may be increased, it becomes in a few years of so course a nature, mixed with rushes, and water plants, that cattle frequently refuse to eat it, and when they do, their appearance proclaims that it is far from being of a nutritious quality. (*Rutland Report*, p. 114.) But this objection is never applicable to meadows skilfully made, and properly managed; and whenever the grasses are coarse, they should be cut earlier if intended for hay. Rushes and water plants are proofs that the meadow lies too flat and is ill managed. (*Code*.)

4115. *The principal impediments to irrigation* are the claims of different individuals on one stream, as millers, canal owners, &c.; the intermixture of property and interests; and the existence in some cases of adverse leases.

4116. *The formation and arrangement of surfaces* for irrigation, however simple in principle, is in practice one of the most difficult operations of agricultural improvement. Whoever, therefore, contemplates extensive and intricate works of this kind, will find it desirable to call in the assistance of a professor and contractor of reputation. In Gloucestershire there are a class of men known as "flooders," who have under them a company of men accustomed to every part of the work, and who accompany their chief to execute works in any part of the country.

## SECT. II. *Of Warping, or the Improvement of Land by Muddy Water.*

4117. *Warping* is a mode of fertilizing lands by depositing a coat of mud on their surface. This may be practised on the borders of large rivers and estuaries, into which sea tides flow; or where floods are frequent, provided, however, that in either case the waters contain alluvial matters in a state of suspension. According to the best information that can be obtained (*Marshal*, in *R. Econ. of York* 1788. *Day, West Riding Report*, p. 171.), warping was first practised on the banks of the Humber, by one Barker, a small farmer at Rawcliff, between 1730 and 1740. It was afterwards extended by Richard Jennings, of Armin, near Howden, in 1743; but it was about the year 1753 before it was attempted by any other person. It was first brought into notice by Marshal, in 1788, and subsequently in the *Report of the West Riding of Yorkshire*, and is now practised by various proprietors and farmers on the Humber, the Trent, and other rivers. It has been long practised in Italy (267.) in a somewhat different manner to what it is in this country, and may be considered as of Egyptian origin.

4118. *The theory of warping* is thus given by Arthur Young. The waters of the tides that come up the Trent, Ouze, Dun, and other rivers which empty themselves into the great estuary of the Humber, is muddy to an excess; insomuch that in summer, if a cylindrical glass, twelve or fifteen inches long, be filled with them, it will presently deposit an inch, and sometimes more, of what is called warp. Where this warp comes from is a dispute. The Humber, at its mouth, is clear water; and no floods in the countries washed by the warp rivers bring it, but, on the contrary, do much mischief by spoiling the warp. In the very driest seasons and longest droughts, it is best and most plentiful. The improvement is perfectly simple, and consists in nothing more than letting in the tide at high water to deposit the warp, and permitting it to run off again as the tide falls; this is the aim and effect. But to render it efficacious, the water must be at command, to keep it out and let it in at pleasure; so that there must not only be a cut or canal made to join the river, but a sluice at the mouth to open or shut, as wanted; and that the water may be of a proper depth on the land to be warped, and also prevented flowing over contiguous lands, whether cultivated or not, banks are raised around the fields to be warped, and from three or four to six or seven feet high, according to circumstances. Thus, if the tract be large, the canal which takes the water, and which, as in irrigation, might be called the grand carrier, may be made several miles long: it has been tried as far as four, so as to warp the lands on each side the whole way, and lateral cuts made in any direction for the same purpose; observing, however, that the effect lessens as you recede from the river; that is, it demands longer time to deposit warp enough for producing benefit.

4119. *The effect of warping* is very different from that of irrigation; for it is not the water that works the effect, but the mud, so that in floods the business ceases, as also in winter; and it is not to manure the soil, but to create it. What the nature of the land may be intended to be warped, is not of the smallest consequence: a bog, clay, sand, peat, are alike eligible: as the warp raises it in one summer from six to sixteen inches thick; and in the hollows or low places, two, three, or four feet, so as to leave the whole piece level. Thus a soil of any depth you please is formed, which consists of mud of a vast fertility, though containing not much besides sand and gravel.

4120. *In respect to the method of executing the work*, it is described in the following manner in *The Agricultural Survey of the West Riding of Yorkshire*, by Lord Hawke.

The land to be warped must be banked round against the river. The banks are made of the earth taken on the spot from the land: they must slope six feet; that is, three feet on each side of the top or crown of the bank, for every foot perpendicular of rise: their top or crown is broader or narrower, according to the impetuosity of the tide, and the weight and quantity of water; and it extends from two feet to twelve: their height is regulated by the height to which the spring tides flow, so as to exclude or let them in at pleasure. In these banks, there are more or fewer openings, according to the size of the ground to be warped, and to the choice of the occupier; but in general they have only two sluices; one called the floodgate, to admit; the other called the clough, to let off the water gently; these are enough for ten or fifteen acres: when the spring tide begins to ebb, the floodgate is opened to admit the tide, the clough having been previously shut by the weight of the water brought up the river by the flow of the tide. As the tide ebbs down the river, the weight or pressure of water being taken from the outside of the clough next the river, the tide water that has been previously admitted by the floodgate opens the clough again, and discharges itself slowly but completely through it.

The cloughs are walled on each side, and so constructed as to let the water run off, between the ebb of the tide admitted, and the flow of the next; and to this point particular attention is paid. The floodgates are placed so high as only to let in the spring tides when opened. They are placed above the level of the common tides. Willows are also occasionally planted on the front of the banks, to break the force of the tides, and defend the banks by raising the front of them with warp thus collected and accumulated: but these willows must never be planted on the banks, as they would destroy them by giving the winds power to shake them.

4121. *The season for warping* begins in the month of July, and proceeds during the summer season, and as this sort of business can only be performed at that season, every occasion of having it executed should be embraced, by having the work in perfect repair, that every tide may be made to produce its full effect. With regard to the advantage of doing this work in the summer months, it may be remarked that at these times the lands not only become the soonest dry, a circumstance which must always fully take place before the process of cultivation can be carried on, but the tides are less mixed with fresh water, in which condition they are constantly found the most effectual.

4122. In regard to *the expense of this mode of improving lands*, it must differ much in different cases, according as the circumstances of situation and distance vary; but it can seldom exceed 12*l.* or 15*l.* the acre, according to Young, and in most instances it must be greatly below such estimates. But it is remarked by Day, in *The Agricultural Survey* of the same district, that no estimate can be made without viewing the situation of the lands to be warped, and the course and distance it will be necessary to carry the warp to such lands: 1st, The situation of the lands must be considered; 2d, The quantity of land the same drains and cloughs will be sufficient to warp; 3d, The expense of building the cloughs, cutting the drains, embanking the lands, &c. An estimate of these expenses being made, then it will be necessary to know the number of acres such cloughs and drains will warp, before any estimate per acre can be made; therefore it will be easy to conceive that the greater quantity of land the same cloughs and drains will warp, the easier the expense will be per acre. In Day's opinion, there are great quantities of land in the country, which might be warped at so small an expense, as from 4*l.* to 8*l.* per acre, which is nothing in comparison to the advantages which arise from it. He has known land which has been raised in value by warping, from 5*l.* to upwards of 40*l.* and 50*l.* per acre; therefore it is easy to conceive that the greatest advantages arise upon the worst land, and the more porous the soil the better, as the wet filters through, and it sooner becomes fit for use. The advantages of warping are very great; as, after lands have been properly warped, they are so enriched thereby, that they will bring very large crops for several years afterwards without any manure; and when it is necessary, the lands might be warped again by opening the old drains, which would be done at a very trifling expense, and would bring crops in succession for many years, with very little or no tillage at all, if the lands were kept free from quick grass, and other weeds, which must be the case in all lands where they are properly managed; besides, the drains which are made for the purpose of warping are the best drains that can be constructed for draining the lands at the time they are not used for warping, which is another very great advantage in low lands.

4123. *The best mode of cultivating new-warped land* must depend principally on the nature of the warp and of the subsoil. In *The Code of Agriculture* it is recommended to sow it with clover, and to let it lie under that crop for two years, in order that it may be brought into a state fit for corn. It does not answer to sow land, immediately after it is warped, with wheat, even though fallowed; but after white or red clover for two years, a good crop of wheat may generally be relied on. Nor is it proper, when land is warped, to plant it with potatoes, or to sow it with flax, being at first of too cold a nature; though these crops may answer, if the land be not too strong for potatoes,

after it has been for two or three years in cultivation. In the quality of warped land, there are most essential differences, some will be very strong, and in the same field some will be very friable. The land nearest the drain is in general the lightest, owing to the quantity of sand that is deposited as soon as the water enters the field: the land farthest from the drain is in general the best. The produce of warped land varies much, but in general it may be stated as abundant. (*Code*, 315.)<sup>1</sup>

SUBJECT. 1. *Of the Irrigation of Arable Lands and of Subterraneous Irrigation.*

4124. *The irrigation of arable lands* is universal in warm countries, and even in the south of France and Italy. The land is laid into narrow beds, between which the water is introduced in furrows during the growth of the crop, and absorbed by the soil. In other cases, the crop is grown in drills and the water introduced between each row in the furrow. In this mode of irrigation no collecting drains are required, as the whole of the water laid on is absorbed by the soil. The principal expense of this operation is that of preparing the lands by throwing the surface into a proper level or levels; the main or carrier is conducted to the higher part of the field, and the rest is easy. A particular description of the practice, as carried on in Tuscany, is given by Sigismondi. (*Agr. de la Toscane*) Some account also of the practice in Spain and the East Indies, will be found in our outline of the agriculture of these countries. (723, and 908.)

4125. *Subterraneous irrigation* appears to have been first practised in Lombardy, and first treated of by Professor Thouin. (*Annales du Musée, &c.*) It consists in saturating a soil with water from below, instead of from the surface, and is effected by surrounding a piece of ground by an open drain or main, and intersecting it by covered drains communicating with this main. If the field is on a level, as in most cases where the practice is adopted in Lombardy, all that is necessary is to fill the main and keep it full till the lands have been sufficiently soaked. But if it lies on a slope, then the lower ends of the drains must be closely stopped, and the water admitted only into the main on the upper side: this main must be kept full till the land is soaked, when the mouths of the lower drains may be opened to carry off the superfluous water. The practice is applicable either to pasture or arable lands.

4126. *In Britain*, subterraneous irrigation has been applied in a very simple manner to drained bogs and morasses, and to fen lands. All that is necessary is to build a sluice in the lower part of the main drain where it quits the drained grounds, and in dry weather to shut down this sluice, so as to dam up the water and throw it back into all the minor open drains, and also the covered drains. This plan has been adopted with success, first, as we believe, by Smith, of Swineridge Muir, in Ayrshire, and subsequently by Johnston, in the case of several bog drainages executed by him in Scotland. It is also practised in Lincolnshire, where it was introduced by the advice of the late engineer Rennie, after the completion of a public drainage at Boston.

SECT. III. *Of the Artificial Means of Procuring Water for the Use of Live Stock.*

4127. *Water is supplied by nature in most parts of the British isles*, and retained with little art both at farmeries and in fields. There are exceptions, however, in different districts, and especially in chalky soils, gravels, and some upland clays. In these cases water is procured for cattle by some of the following means: By conducting a stream, from a distant source, as in a work of irrigation; by collecting rain-water from roads, ditches, or sloping surfaces, in artificial ponds, or reservoirs; by collecting it from the roofs of buildings, and preserving it in covered cisterns; by sinking a well, or a pipe, either in the field, or the farm yard; and by artificial springs.

4128. *An artificial stream* will in most cases be found too expensive an operation to be undertaken for the supply of drinking water for live stock; but this purpose may frequently be combined with that of watering lands or driving machinery. In the North Riding of Yorkshire, there is a tract extending for many miles, entirely destitute of water, except what flows along the bottoms of the deep valleys by which it is intersected, and little relief could consequently be afforded by streams thus distantly and inconveniently situated, to the inhabitants of the uplands, or their cattle. About the year 1770, a person of the name of Ford devised the means of watering this district, by means of rills brought from the springs that break out at the foot of the still loftier moorland hills, that run parallel to and to the north of this tract, in some instances at the distance of about ten miles. The springs he collected into one channel, which he carried, in a winding direction, about the intervening tract, according to its level, and along the sides of the valleys, until he gained the summit of the arid country which he wished to supply with water; and when this was accomplished, the water was easily conveyed to the places desired, and also to the ponds in all the fields, over a considerable tract of ground.

4129. *Collecting rain-water from roads, &c. in ponds, or drinking pools.* Formerly, it is probable, something of this art has been practised throughout the kingdom: most villages, and many old farmsteads, have drinking pools for stock, which appear to have been formed or assisted by art. In strong-land grazing districts, pits have evidently been dug, to catch the rain-water fortuitously collected, by furrows and ditches; or by landsprings. On the chalk hills of the southern counties, the art has been long established, and continued down to the present time; and, on the wolds or chalk hills of Yorkshire, an improved practice has been introduced by Robert Gardner of Kilham, which gained an establishment towards the end of the last century, and has spread rapidly over the adjacent heights, with great profit to the country. In every dry-land situation, it may be practised with high advantage to an estate, and is well entitled to attention.

4130. *The mode of constructing these collecting ponds* is described in *The Annals of Agriculture* (vol. vi.), and illustrated by a section (fig. 533.). The ground plan is circular, and generally forty or

533

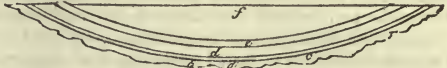

fifty feet in diameter, and the excavation is not made deeper in the centre than five feet. This excavation being cleared out, a layer of clay (*a, b, c*) sufficiently moistened, is to be carefully beaten and trod down into a compact and solid body of about the thickness of a foot. Upon this a layer of quick-lime is finely and uniformly spread over the whole, of one inch or upwards in thickness. Next is another layer of clay of about one foot in thickness (*d*), which is to be trodden and rammed down as the former; upon this are spread stones or coarse gravel (*e*) of such thickness as may prevent the pond receiving any injury from the treading of cattle, who would otherwise break through the body of the clay and lime, and by so doing let out the water; after this, the pond will remain five feet deep and forty-five feet diameter; the size they are usually made.

4131. *Brick-clay is by no means required* for the ponds; any earth sufficiently tenacious to bear beating into a solid compact body, though not approaching to a pure clay, will answer the purpose very well.

4132. *The preferable situation to make the pond* is a little valley, or at the bottom of a declivity, or near a high road, in which situation a stream of water may be brought into it after sudden showers or thaws, the object being to get it filled as soon as possible after it is made, that the sun and winds may not crack the clay; if it is not likely to be filled soon, some straw or litter must be spread over it; but in general, after it is once filled, the rains that fall in the course of the year will keep it full, no water being lost otherwise than by evaporation and the consumption of cattle.

4133. *The whole excellence of the pond depends upon the lime*; care must be taken to spread it regularly and uniformly over the surface of the lower bed of clay; it is well known that ponds made of clay alone, however good its quality, and whatever care may be exerted in the execution, will frequently not hold water; these with the above precautions rarely fail. By what means the lime prevents the loss of water is not exactly known; one of these two is probably the cause; either the lime sets like terrace into a body impervious to water; or its causticity prevents the worms in dry weather from penetrating through the clay in search of the water; certain, however, it is, that with lime, thus applied, ponds may be made in sand, however porous, or on rocks however open, in neither of which situations are they to be depended upon when made with clay alone. On this mode of making ponds for the use of live stock, there are several circumstances of the process more fully detailed in *The Rural Economy of Yorkshire*.

4134. *In constructing ponds in loamy soils* all that is necessary is to coat the bottom over with clay or loam to the depth of eighteen inches or two feet, and then to puddle or work this well with water till it becomes a homogeneous layer impenetrable to that element. If clay or loamy earth cannot be obtained, any earth not very much inclined to sand may be substituted, but it will require more labor in puddling. On clayey soils very little more is necessary than smoothing the surface of the excavation, and perhaps watering it and beating it to a smooth surface with rammers. The pond being now formed, the next operation is to coat it over with coarse gravel to the depth of at least eighteen inches; or, what is preferable, chalk and flints with gravel; or, best of all, to causeway or pave it. It is also very desirable to pave or gravel the surface for the breadth of at least two yards round the pond, in order to prevent the cattle from poaching it when they come to drink.

4135. *An economical mode of forming ponds* is often adopted on clayey soils where gravel or stone for paving is scarce. It consists in adopting the horse shoe form as the ground plan of the excavation, and cutting all the sides steep, or at an angle of 45 or 50 degrees, excepting the part answering to the heel of the shoe (fig. 534 *a*), which is well gravelled or paved as the only entrance for the cattle. The excavated earth serves to raise the high side of the pond (*b*), which is generally guarded by a fence or a few trees.



The disadvantage of such ponds is, that one is required for every field, or at least for every two fields; whereas a pond sloped on all sides may supply four fields or even a greater number. (*fig. 535.*)

4136. *The Gloucestershire ponds* are made either of a square or a circular shape, and generally so situated, as to furnish a supply to four fields. (*fig. 535.*) Three layers of clay, free from the smallest stone or gravel, are so worked in, as to form an impenetrable cement. The whole is afterwards covered with sand, and finished with pavement. (*Gloucestershire Report, p. 31.*)

534

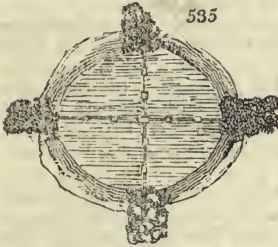
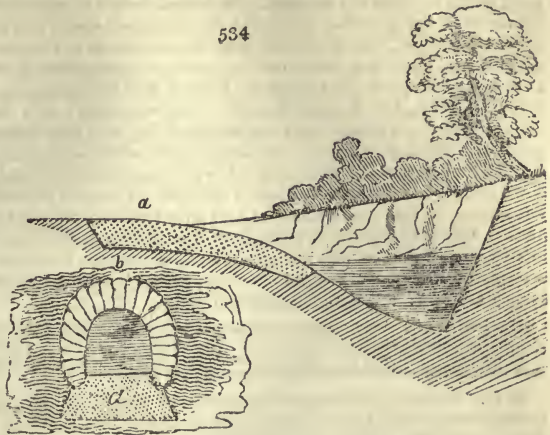

4137. *The Derbyshire artificial meers, or cattle ponds*, are made in their dry rocky pastures, with great success. Having selected a low situation for the purpose, they deepen it ten or twenty yards across, and spread over the whole excavation a layer, about five inches thick, of refuse slacked lime and coal cinders; then they spread, trample, and ram down a stratum of well tempered clay, about four inches thick; and upon this they spread a second bed of clay, in a similar manner, of the same thickness; the whole of the bottom and edges of the meer is then paved with rubble stones; and small rubble stones, several inches thick, are

spread upon the pavement. (*Derbyshire Report, vol. i. p. 494.*)

4138. *The situation of field ponds*, where practicable, should be at the intersection of fences, so as one may serve as many fields as possible. This, however, cannot be the best situation in every case, because it may happen that water cannot there be collected. At the same time, a low situation is not desirable in every case, because it may be so circumstanced that too much dirty water may run into it during rains.

4139. *Trees are frequently planted round ponds*, and with seeming propriety, as their effect is beautiful, and they shade the water from the direct influence of the sun during summer; but in autumn their leaves certainly tend to render the water impure for a time. As most leaves are of an astringent quality, perhaps there may be no injury sustained by cattle from drinking such water at first; but after some time the leaves begin to decay and occasion a sort of fermentation, which, till it subsides in the beginning of frosty weather, renders the water somewhat unhealthy and very unsightly.

4140. *Wells*, where no better method of procuring water can be devised, may be resorted to, both for fields and farmeries; but the great objection to them is the labor required to pump up, or otherwise raise the water, and the consequent risk of neglect. Before proceeding to dig a well, it ought first to be determined on whether a mere reservoir for the water which oozes out of the surface soil is desired or obtainable, or a perpetual spring. If the former is the object in view, a depth of fifteen or twenty feet may probably suffice, though this cannot be expected to afford a constant supply unless a watery vein or spring is hit on: if the latter, the depth may be very various, there being instances of 300 and 500 feet having been cut through before a permanent supply of water was found. (*Middlesex, Surrey, and Hampshire Reports.*)

4141. *The art of well-digging* is generally carried on by persons who devote themselves exclusively to that department. The site being fixed on, the ground-plan is a circle, generally of not more than six or eight feet in diameter: the digger then works down by means of a small short-handled spade, and a small implement of the pick-axe kind; the earthy materials being drawn up in buckets by the hand or a windlass, fixed over the opening for the purpose. Where persons conversant with this sort of business are employed, they usually manage the whole of the work, bricking round the sides with great facility and readiness; but in other cases, it will be necessary to have a bricklayer to execute this part of the business.

4142. *Steining.* There are two methods of building the stone or brick within the well, which is called the steining. In one of these a circular ring is formed, of the same diameter as the intended well; and the timber of which it is composed is of the size of the brick-courses, with which the well is to be lined. The lower edge of this circle is made sharp, and shod with iron, so that it has a tendency to cut into the ground; this circular kirk is placed flat upon the ground, and the bricks are built upon it to a considerable height, like a circular wall. The well-digger gets within this circle, and digs away the earth at the bottom; the weight of the wall then forces the kirk, and the brick-work with which it is loaded, to descend in the earth, and as fast as the earth is removed it sinks deeper, and the circular brick-wall is increased or raised at top as fast as it sinks down; but when it gets very deep, it will sink no longer, particularly if it passes through soft strata: in this case, a second kirk of a smaller size is sometimes began within the first. When a kirk will not sink from the softness of the strata, or when it is required to stop out water, the bricks or stones must be laid one by one at the bottom of the work, taking care that the work is not left unsupported in such a manner as to let the bricks fall as they are laid: this is called under-pinning.

4143. *Noxious air.* Well-diggers experience sometimes great difficulty from a *noxious air* which fills the well, and suffocates them if they breathe it. The usual mode of clearing wells of noxious air is, by means of a large pair of bellows, and a long leathern pipe, which is hung down into the well to the bottom, and fresh air is forced down to the bottom by working the bellows.

4144. *The use of the auger* is common in well-digging, both in ascertaining before commencement the nature of the strata to be dug into, and also in course of digging for the same purpose; and because, by boring in the bottom of a well to a considerable depth, the spring is sometimes hit upon, and digging rendered no longer necessary.

4145. In particular situations, *the use of the borer alone* may procure an adequate supply of water. This mode appears to have been long resorted to in this and other countries. From what we have already stated as to the disposition of strata, the conditions requisite for its success will be readily conceived; *viz.* watery strata connected with others on a higher level: the pressure of the water contained in the higher parts of such strata on the lower will readily force up the latter through any orifice, however small. All that is necessary, therefore, is to bore down to the stratum containing the water, and having completed the bore, to insert a pipe, which may either be left to overflow into a cistern, or it may terminate in a pump. In many cases, water may be found in this way, and yet not in sufficient quantity and force to rise to the surface; in such cases a well may be sunk to a certain depth, and the auger-hole made, and the pipe inserted in it in the bottom of the well. From the bottom it may be pumped up to the surface by any of the usual modes.

4146. *As an example of well-digging combined with boring*, we give that of a well dug at a brewery at Chelsea, Middlesex, in 1793. The situation was within 20 or 30 feet of the edge of the Thames, and the depth 394 feet, mostly through a blue clay or marl. At the depth of near fifty feet a quantity of loose coal, twelve inches in thickness, was discovered: and a little sand and gravel was found about the same depth. The well-digger usually bored about ten, fifteen, or twenty feet at a time lower than his work as he went on, and on the last boring, when the rod was about fifteen feet below the bottom of the well, the man felt, as the first signal of water, a rolling motion, something like the gentle motion of a coach passing over pavement; upon his continuing to bore, the water presently pushed its way by the side of the auger with great force, scarcely allowing him time to withdraw the borer, put that and his other tools into the bucket and be drawn up to the top of the well. The water soon rose to the height of two hundred feet.

4147. In a case which occurred in digging a well at *Dr. Darwin's*, near Derby, the water rose so much higher than the surface of the ground, that by confining it in a tube, he raised it to the upper part of the house. (*Rees's Cyclopædia*, art. *Well*, and *Derbyshire Rep.*)

4148. *The process of boring the earth for spring water* has of late been practised, with great success, in various parts of England, chiefly by a person named Good, of Huntingdon. In the neighborhood of London, many fountains of pure spring-water have lately been obtained by these means. We may particularly name those at Tottenham, Middlesex, and Mitcham, Surrey, both of which afford a continuous and abundant flow of water, equal to about eight gallons per minute. A very copious fountain, which rises twenty feet above the surface, has lately been obtained by the same means in the grounds of Ravenscroft Park, the seat of G. Scott, Esq., near Hammersmith. Indeed there can be little doubt that in the great majority of situations, not only in Britain, but throughout the world, water might be found by boring or digging down a few scores of feet.

4149. *The boring is effected by means of an auger*, similar to the instrument employed in boring for coal. The auger is connected to an iron rod, about four or five feet long, which is introduced into the ground in a perpendicular direction, a slight power being exerted on the top: it is turned by manual labor. When the auger has descended as far as the length of the rod will permit by cutting its way through the ground, it is then drawn up by a shaft and windlass; and the earth which occupied the space thus bored, is brought up with it and discharged from the auger. Another length of rod is added to the auger as it gets deeper,

by means of coupling boxes, and a cast-iron tube is introduced into the hole, and driven down. The length of this tube is about sixteen feet with an orifice of about four and a half inches, and an upper flange on the top of which the superstructure of the fountain is to be raised, whether plain or ornamental: the use of this tube is to exclude the land springs, and assist in keeping the further progress of the borer perpendicular. — Additional rods being now coupled to the auger, the boring proceeds until the spring discovers itself, which, in general, has been found at the commencement of a stratum of sand, about one hundred feet below the surface. Tin pipes are now introduced into the bore, of about three inches diameter, and twenty feet long. When the first length of pipe has been forced nearly down, another similar pipe is soldered on to the top of it: the pipe is then driven further down, and a third length soldered to the top of the last, and so on until the whole bore is encased by one continued pipe, from top to bottom, by which the earth is prevented from falling in, and the passage of the water kept perfectly clear.

4150. *As various obstructions must occasionally intercept the progress of the auger, different kinds of instruments are employed for removing them, of particular construction and action.* When rocky strata are to be penetrated, a kind of weighted pecker is let down, by which the column of the rock is broken, or pounded into small pieces, the fragments of which are collected, and brought up by a sort of box auger.

4151. *This operation has not yet failed of procuring water in any one instance, though, by the spring flowing to the level of its source, the water does not always flow up above the ground, and indeed sometimes does not reach the surface; but, under these circumstances, by sinking a well a short distance, the water will flow plentifully.* According to the altitude of the head, or source, of the spring, will be its force in rising. If the bore be made in a valley, and the source of the spring should be in the interior of a neighboring hill, the stream would flow through the meandering fissures of the earth and rise to its level, wherever a vent is given; and under these circumstances, would flow above the surface of the outlet, by a pressure equal to the weight of a column of water between its level and the altitude of the source. If the source be upon the same level as the outlet (whatever their distance apart), the water will flow to the surface only, without running over. But, if the source should be below the level of the outlet, then it will be necessary to sink a well down to that level and a little lower, before a free supply of water will be furnished.

4152. *The expense of this process appears to be very trivial; the charges being four-pence per foot for sinking the first ten feet; eight-pence per foot for the second ten feet; twelve-pence for the third; and so on; increasing four-pence per foot for every additional ten feet of descent; this charge being for labor, exclusive of the cost of tubes: whereas, the expense of ordinary well-sinking amounts to about eight times that sum.* The advantages of flowing springs of good water, which, by these means, may always be obtained on the sides of roads, and in a variety of other places where water is not at present found, are incalculable; the cost very small, and the operation easy and expeditious. Within one week, the operation of boring for the spring at Tottenham, was begun and finished, a depth of one hundred and five feet.

4153. *Of the various modes of raising water from deep wells, the pump is most convenient, and the lever and bucket the most simple.* When a constant supply is wanted from a very deep well, machinery (fig. 536.) may be erected over it, and driven by an old horse or ass.

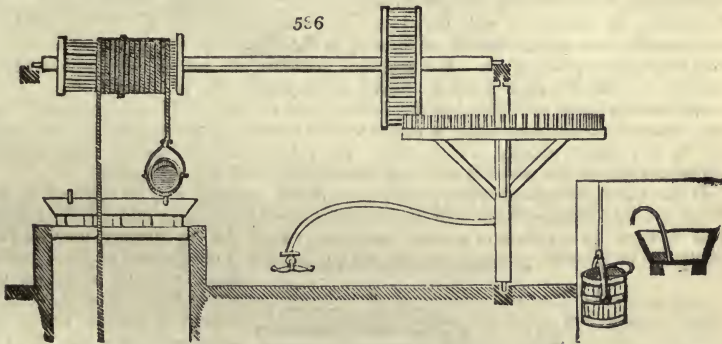

4154. *Pumps are of various kinds, as the lifting pump; the forcing pump, for very deep wells; the suction pump; and the roller pump, a recent invention for such as do not exceed thirty-three feet in depth.* A good pump for urine pits or reservoirs, where the water is not to be raised above twenty-eight or thirty feet in depth, is that of Robertson Buchannan, author of *A Treatise on Heating by Steam, &c.*, because this pump, which acts by the pressure of the atmosphere, will raise drainings of dunghills, or even water thickened by mud, sand, or gravel. “The points in which it differs from the common pump, and by which it excels, are, that it discharges the water below the piston, and has its valves lying near each other. The advantages of this arrangement are — that the sand or other matter, which may be in the water, is discharged without injuring the barrel or the piston-leathers; so that besides avoiding unnecessary tear and wear, the power of the pump is preserved, and it is not apt to be diminished or destroyed in moments of danger, as is often the case with the common and chain pumps; that the valves are not confined to any particular dimensions, but may be made capable of discharging every thing that can rise in the suction-piece without danger of being choked; and that if, upon any occasion, there should happen to be an obstruction in the valves, they are both within the reach of a person’s hand, and may be cleared at once, without the disjunction of any part of the pump. It is a simple and durable pump, and may be made either of metal or wood, at a moderate expense.” Where clear water only is to be raised,

Aust's (of Hoxton) *curvilinear* pump is preferable to the common sort. The advantages depend on the curvilinear form of the barrel, which allows, and indeed obliges, the rod, the handle, and the lever, on which it works, to be all in one piece. Hence simplicity, cheapness, precision of action, more water discharged in proportion to the diameter of the barrel, and less frequent repairs. (*Repertory of Arts*, Jan. 1821.) Perkins's square-barrelled pump is a powerful engine (*London Journal*, &c.); but this and other contrivances for raising water, though of great merit, cannot often be made available by the improver from their not having come into general use.

4155. *An old but ingenious mode of raising water from a well to the upper part of a house* (fig. 537.), is sometimes adopted on the continent. A post is fixed close to the well; this is connected with the opening in the upper part of the house, where the water is to be introduced, by a fixed cord (a). On this cord a wooden collar (b) is placed, and slides freely from one end to the other: the bucket rope is put through a hole in the collar, and over a pulley in the window in the upper part of the house, and thus the bucket is first raised perpendicularly from the water in the well till it comes in contact with the collar, when the power being continued, the collar slides along the fixed rope till it reaches the operator at the window. (*Last. Col. de Machines*, &c.)

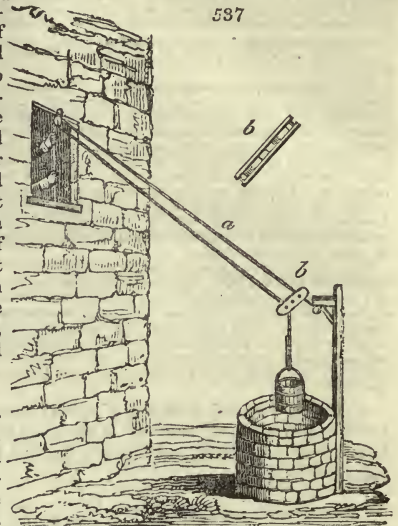

4156. *Artificial springs.* Marshal, seeing the formation of natural springs, and observing the effect of subsoil drains, and being, at the same time, aware of an objection to roof water, which, though more wholesome, is seldom so well tasted as spring water; was led to the idea of forming artificial land-springs, to supply farmsteads with water, in dry situations. He proposes arresting the rain-water that has filtered through the soil of a grass ground, situated on the upper side of the buildings, in covered drains, clayed and dished at the bottom, and partially filled with pebbles or other open materials: thus conveying it into a well or cistern, in the manner of roof water: and by this means uniting, it is probable, the palatableness of spring water with the wholesomeness of that which is collected immediately from the atmosphere.

4157. *Water for common farm-yard and domestic purposes* may be obtained in most situations, by collecting that which falls on the roofs of the farmery and dwelling-house. This is done by a system of gutters and pipes, which, for the farmery, may lead to a cistern or tank under ground; and for the family, that from the roof of the dwelling-

house may be conducted to a tub. Before using it, it may be filtered in various ways: one is, to have three tubs all of the same size (fig. 538.), the first (a) nearly filled with gravel or very coarse sand; the second (b), with powdered charcoal, with a stratum of sponge covering it, and the third (c) empty. The water falls from the gutter or spout into the top of the gravel barrel, and filtering through it, ascends through the charcoal and sponge in the next, and passes over clear and sweet into the receiving barrel (c); from which it is drawn as wanted. Where one receiving barrel is not enough, two or

538

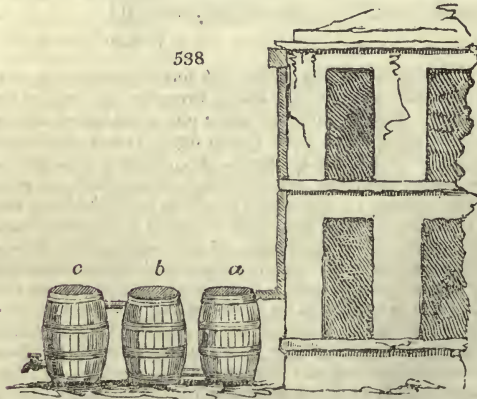

more may be added, or the water may be led from it to an underground cistern or cellar.

4158. *Filtering water on a large scale* may be effected by emptying one pond into another, through a conduit of any kind filled with gravel, sand, and charcoal.

#### CHAP. IV.

##### *Of the Improvement of Lands lying Waste, so as to fit them for Farm-Culture.*

4159. *Of waste lands*, many descriptions are best improved by planting, and therefore are to be considered as disposed of in that way in the laying out or arrangement of an estate; but there are others which may be more profitably occupied as farm-lands, and it is the preparing or bringing these into a state of culture, which is the business of the present chapter. Such lands may be classed as mountainous or hilly grounds, rocky or stoney surfaces, moors, bogs or peat-mosses, marshes, woody wastes or wealds, warrens or downs, and sea-shores or beaches. In the improvement of these subjects, many of the operations are such as are performed by temporary occupiers or farmers; but as in this case such occupiers have always extraordinary encouragement from the landlords, either in the shape of a low rent, of money advanced, of long leases, or of all of these; we consider it preferable to treat of them as permanent, or fundamental improvements, than to consider them as parts of farm-culture.

##### SECT. I. *Of mountainous and hilly Grounds and their Improvement.*

4160. *The upper parts of mountains* may be considered as among the least improvable parts of the earth's surface, from the impossibility of ever improving their climate. "The highest peaks and ridges are mostly naked granite, slate, or volcanic productions. Their more elevated sides, and the tops of those of moderate height, are usually covered by a thin soil, producing a short dry herbage, which is frequently mixed with a dwarf, or stunted heath. Where the soil is not injured by moisture, these are best calculated for sheep. When the height of mountains exceeds 800 feet of elevation above the level of the sea, unless covered either with natural woods or artificial plantations, they can only be profitably used in pasture." (*Code.*)

4161. *The hills, or land less elevated than mountains*, have, in general, a deeper and moister soil, and produce a more luxuriant herbage, but of a coarse quality; hence they are better adapted for small hardy cattle. Though the summits of hills are generally unfit for raising grain, yet the plough is gradually ascending along their sloping sides, and within the last thirty years many thousand acres in such situations have been reclaimed in the united kingdom.

4162. *Steep lands along the sides of rivers and small streams* are often inaccessible to the plough, and unfit for tillage. The more rugged of these are well calculated for woods or coppice; while those in more favorable situations and climates may be converted into orchards. (*Code of Agr. 161.*)

##### SECT. II. *Of rocky or stoney Surfaces.*

4163. *Rocky and stoney lands* are common in the valleys of a hilly or mountainous country, and sometimes, as in Aberdeenshire, they cover immense tracts of flat surface.

4164. *When rocks protrude from the surface here and there in fragments of a few tons*, and it is considered desirable to render the field or scene fit for aration, the only mode is to rend them asunder by gunpowder, and then carry off the fragments for walls, drains, roads, or buildings; or, if they are not wanted for these or any other purpose, to bury them so deep in the ground as to be out of the reach of the plough. But where rocks rise in considerable masses of several poles in diameter, it will generally be found preferable to enclose and plant them. Clefts and crevices are found in all rocks which have been long exposed to the air and weather, and in these may be inserted young plants, or seeds, or both. Such masses being enclosed by rough stone walls, formed from the more detached fragments, or from loose stones, will grow up and be at once highly ornamental and useful as shelter. It is true they will interrupt the progress of the plough in a straight line, but not more so than the rock if left in a state of nature. When a rocky surface is not intended to be ploughed, all that is necessary is to remove as many of the solitary rocks as possible, and either enclose and plant the rest, or cover them with earth.

4165. *The stones which impede the improvement of land* are either loose, thrown up when the land is trenched, or ploughed; or fixed in the earth, and not to be removed without much labor and expense.

4166. *Loose stones* may often be converted into use for the purpose of covered drains, of constructing walls or fences, or making and repairing the roads on the farm, or in the

neighborhood; and on these accounts are sometimes worth the trouble of collecting. They may be removed, with the least inconvenience, when the land is fallowed. Where loose stones are of a moderate size, they are sometimes found advantageous rather than detrimental, as in the stone-brash soils of Somersetshire and other districts. They prevent evaporation, and thus preserve moisture in the soil. Hence the old remark, that farmers have been induced to bring back again to their corn-fields those very stones they have been induced to carry off. (*Code.*)

4167. *Where stones are large and fixed in the earth, if they appear above the surface, they should be removed before the ploughing of the waste commences: but where they are concealed under the surface, various modes to get rid of them have been adopted. In some parts of Yorkshire, the whole surface is gone over with sharp prongs, which, at the distance of every twelve or fourteen inches, are thrust into the ground to the depth of about a foot, to ascertain where stones are to be met with. The spot is marked by a twig, and the stones are removed before the land is ploughed. Sometimes the plough is used without such previous examination, and the place marked where stones are encountered, that they may be taken away; and sometimes, in order to discover and remove such stones, the land is trenched by the spade. (Communications to the Board of Agr. vol. ii. p. 253.)*

4168. *Stones above the surface may be avoided by the ploughman, though not without loss of ground; but stones under the surface are often not discovered till the plough is drawn against them, and perhaps broken, by which a day's work is sometimes lost. A wooden bolt, however, to unite the horse-trees to the chain of the plough, may prevent mischief by giving way. Clearing the ground from stones not only prevents such mischiefs, but is attended with actual profit. When removed, they may be used for various purposes, and are often less expensive than if dug, or purchased at a quarry. The soil round a large stone is likewise, in general, the best in the field, and is bought at a low rate by the expense of taking out the stone, as the plough has thus access to all the land around it. In stoney land the plough must proceed slowly, and cannot perform half so much work as it ought to do; but, after such impediments have been removed, the field may be ploughed with the usual facility and cheapness, and in a much more perfect manner. It frequently happens, that when working stoney land, more expense is incurred in one season by the breaking of ploughs, besides the injury done to the horses and harness, than would cure the evil. (Gen. Rep. of Scot. vol. ii. p. 256; Kaimes's Gent. Farmer, p. 58.)*

4169. There are various modes of getting rid of stones. They are generally of such a size as admit of their being conveyed away in carts, or other vehicles calculated for that purpose. Some ingenious artificers have constructed machines for raising them, when of a large size. On some occasions, pits have been dug close to large stones, and the latter have been turned into the former, at such a depth as to lie out of the reach of the plough. But it is frequently necessary to reduce their size by the force of gunpowder before they can be removed. Loose stones are commonly moved by levers, and rolled on a sledge; but sometimes they are raised by a block and tackle attached to a triangle with a pair of callipers to hold the stone (*fig. 539.*). The stone may also be raised by boring a hole in it obliquely and then inserting an iron bolt with an eye (*fig. 540.*), which though loose will yet serve to raise the stone in a perpendicular direction.



540



4170. *The mode of bursting or rending rocks or stones by gunpowder, is a simple, though dangerous operation. When a perforation or hole is to be made in a rock or stone for the purpose of blasting with gunpowder, the prudent workman considers the nature of the rock, and the inclination or dip of the strata, if it is not a detached fragment, and from these determines the calibre, and the depth and direction of the bore or recipient for the gunpowder. According to circumstances, the diameter of the hole varies from half an inch to two inches and a half, the depth from a few inches to many feet, and the direction*

varies to all the angles from the perpendicular to the horizontal. The implements for the performance of this operation are rude, and so extremely simple and familiar, as hardly to require description; and the whole operation of boring and blasting rocks is so easily performed, that, in the space of a few weeks, an intelligent laborer may become an expert quarrier.

4171. The operation of *ramming* frequently gives rise to accidents, but a recent improvement, that of using a wadding of loose sand, or of any earthy matter in a dry state,

answers all the purposes of the firmest ramming or wadding. It has been used for upwards of ten years at Lord Elgin's extensive mining operations at Charlestown in Fifeshire, and also in removing immense bodies of rock from the Calton hill at Edinburgh, by Stevenson, an eminent engineer, whose article on the subject of blasting, in *The Supplement to the Encyc. Brit.*, deserves the attention of such as use the process in working quarries or clearing rocky or stoney grounds.

### SECT. III. *Of improving Woody Wastes or Wealds.*

4172. *With surfaces partially covered with bushes and stumps of trees, ferns, &c., the obvious improvement is to grub them up, and apply the land to cultivation according to its nature.*

4173. *The growth of large trees is a sign that the soil is naturally fertile. It must also have been enriched by the quantity of leaves which in the course of ages have fallen and rotted upon the surface. Such are the beneficial effects of this process, that after the trees have been cut down, the soil has often been kept under crops of grain for a number of years without interruption, or any addition of manure. Land thus treated, however, ultimately becomes so much reduced, by great exhaustion, that it will not bear a crop worth the expense of seed and labor. (Communications to the Board of Agriculture, vol. ii. p. 257.) It is evident, however, that this deterioration entirely proceeds from the improvident management previously adopted. In reclaiming such wastes, the branches of trees that are felled are generally collected and burnt; and the ashes are either in whole or in part, spread on the ground, by which the fertility of the soil is excited. Indeed, where there is no demand for timber on the spot, nor the means of conveyance to any advantageous market, the whole wood is burnt, and the ashes applied as manure.*

4174. *Much coppice land has been grubbed up in various parts of England, and brought into tillage. Sometimes woods are grubbed for pasture merely. In that case the ground should be as little broken as possible, because the surface of the land, owing to the dead wood and leaves rotting time out of mind upon it, is much better than the mould below. It soon gets into good pasture as grass land, without sowing any seed. (Communications to the Board of Agriculture, vol. iv. p. 42.) But by far the most eligible mode of converting wood land into arable, is merely to cut down the trees, and to leave the land in a state of grass until the roots have decayed, cutting down with the scythe from time to time any young shoots that may arise. The roots in this way, instead of being a cause of anxiety and expense, as they generally are, become a source of improvement; and a grassy surface is prepared for the operation of sod-burning. (Marshal's Yorkshire, vol. i. p. 316.)*

4175. *Natural woods and plantations have been successfully grubbed up in Scotland. In the lower Torwood in Stirlingshire, many acres of natural coppice were cleared; and the land is now become as valuable as any in the neighborhood. (Stirlingshire Report, p. 213.) On the banks of the Clyde and the Avon, coppices have been cut down, and after being drained, cultivated, and manured, the land has been converted into productive orchards. In Perthshire also, several thousand acres of plantations have been rooted out, the soil subjected to the plough, converted into good arable land, and profitably employed in tillage. (Perthshire Report, p. 329.)*

4176. *For pulling up or rending asunder the roots of large trees, various machines and contrivances have been invented. Clearing away the earth and splitting with wedges is the usual mode; but blasting is also, as in the case of rocks and stones, occasionally resorted to.*

For this purpose a new instrument, called the *blasting-screw* (fig. 541.) has been lately applied with considerable success to the rending or splitting of large trees and logs of timber. It consists of a screw (a), an auger (b, c), and charging-piece (d). The screw is wrought into an auger-hole, bored in the centre of the timber; here the charge of powder is inserted, and the orifice of the hole in the log is then shut up or closed with the screw, when a match or piece of cord, prepared with saltpetre, is introduced into a small hole (a), left in the screw for this purpose, by which the powder is ignited. The application of this screw to the purposes of blasting is not very obviously necessary, because, from what we have seen (4171.) it would appear that the auger-hole being charged with powder and sand, would answer every purpose. One great objection to the process of blasting applied to the rending of timber is, the irregular and uncertain direction of the fracture, by which great waste is sometimes occasioned. It may, however, be necessary

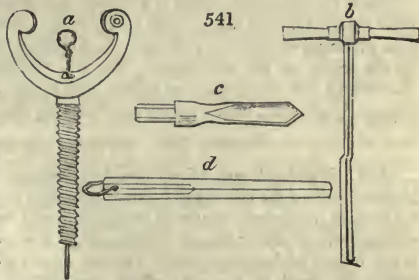

to resort to this mode of breaking up large trees, when cut down and left in inaccessible situations, where a great force of men and of implements cannot easily be procured or applied; and certainly it is one of the most effectual modes of tearing their stools or roots in pieces. (*Sup. Encyc. Brit. art. Blasting.*)

4177. *Land covered with furze, broom, and other shrubs*, is generally well adapted for cultivation. The furze, or whin (*Ulex europæus*), will grow in a dense clay soil; and where they are found in a thriving state, every species of grain, of roots and grasses, may be cultivated with advantage. The broom, on the other hand, prefers a dry, gravelly, or sandy soil, such as is adapted for the culture of turnips. A large proportion of the arable land, in the richest districts of England and Scotland, was originally covered by these two plants; and vast tracts still remain in that state, which might be profitably brought under cultivation. For that purpose, the shrubs ought to be cut down, the ground trenched, or the plants rooted out by a strong plough, drawn by four or six horses, and the roots and shrubs (if not wanted for other purposes) burnt in heaps, and the ashes spread equally over the surface. (*Com. to the B. of Ag. vol. ii. p. 260.*) In many places, shrubs and brushwood may be sold for more than the expense of rooting them out. When coal is not abundant, and limestone or chalk can be had, the furze should be employed in burning the lime that is used in carrying on the improvement. (*Oxfordshire Report, p. 232.*) It requires constant attention, however, to prevent such plants from again getting possession of the ground, when it is restored to pasture. This can best be effected, by ploughing up the land occasionally, taking a few crops of potatoes, turnips, or tares in rows, and restoring it to be pastured by sheep. In moist weather also, the young plants should be pulled up and destroyed. (*Code.*)

4178. *Fern (Pteris and Osmunda)* is a very troublesome weed to extirpate, as, in many soils, it sends down its roots into the under stratum, beyond the reach of the deepest ploughing; but it is a sign of the goodness of any soil, where it grows to a large size. June or July are the best seasons for destroying it, when the plants are full of sap, and when they ought to be frequently cut. They are not, however, easily subdued, often appearing after a rotation of seven years, including a fallow, and sometimes requiring another rotation, and cutting them repeatedly, before their final disappearance can be effected. Lime, in its caustic state, is peculiarly hostile to fern; at the same time, it can hardly be completely eradicated, but by frequent cultivation, and by green crops assisted by the hoe. (*Oxfordshire Report, p. 234. and 240.*)

4179. *The heath (Erica)* is a hardy plant, palatable and nutritious to sheep; and under its protection, coarse grasses are often produced. When young, or in flower, it may be cut and converted into an inferior species of winter provision for stock. But where it can be obtained, it is desirable to have grass in its stead. For that purpose, the land may be flooded, or the heath burnt in March or April, and kept free from stock for eighteen months; in consequence of which, many new grasses will spring up, from the destruction of the heath, and the enriching quality of the ashes. The improvement is very great; more especially if the land be drained, and lime or compost be applied. (*Gen. Rep. of Scot. vol. ii. p. 359.*) But if the land be too soon pastured, the grasses, being weak and tender, the sheep or cattle will pull them up with their roots, and the pasture is materially injured. (*Statistical Account of Scotland, vol. iv. p. 465.*) Where it is proposed to cultivate the land for arable crops, the lime applied should be in a finely powdered state, highly caustic, and as equally spread as possible. (*Com. to the B. of Ag. vol. ii. p. 264.*)

4180. *Paring and burning* is a speedy and effectual mode of bringing a surface covered with coarse herbage into a state of culture. Some have recommended making a compost of the pared surface, with lime; or building folds or earthen walls of the sods, which, by the action of the atmosphere, become friable and fertile; but these processes are slower and not so effectual as paring and burning. In coarse rough pastures, ant-hills frequently abound, which paring and burning effectually destroys. (*Code.*)

#### SECT. IV. *Of Moors and their Improvements.*

4181. *Moorlands* are of various descriptions. Sometimes they are in low and mild situations, where the upper soil is thin, or scantily supplied with vegetable mould; and where the bottom or under-stratum is impervious and barren. These, in general, may be reclaimed with more or less advantage, according as they are near manure or markets, and other means of improvement. Others, on the contrary, are in situations much elevated above the level of the sea; where the surface is covered with heath and other coarse plants, and frequently encumbered with stones. Such moors are seldom worth the expense of cultivation, and from their height are only calculated for woods or pasturage.

4182. *Moors which are not placed in high or bleak situations*, where the surface is close-swarded, or covered with plants, and where the subsoil is naturally either not altogether wet, or capable of being made sufficiently dry at a moderate expense, may not only be reclaimed, but often can be highly improved by the common operations of farm culture;



by paring and burning; by fallow and liming; or by trenching or deep ploughing. Vast improvements on different sorts of moory lands have been made in Yorkshire, where there are immense tracts of moors. It is stated in *The Agricultural Report of the North Riding of Yorkshire*, that an improvement was made upon Lockton moor, on a quantity of land of about seventy acres, which would not let for more than 1s. per acre, before it was enclosed. Of this forty-eight acres were pared and burnt, and sown with rape, except about an acre sown with rye; the produce about sixty quarters. The rye grew very strong, and in height not less than six feet, and was sold, while standing, for five guineas the acre. The land was only once ploughed, otherwise the crop of rape would probably have been much better. One hundred and twenty chaldrons (each thirty-two bushels) of lime were ploughed into the field; which, for want of more frequent ploughing, probably was not of the service it otherwise might have been. Part of the land was afterwards sown down with oats and grass seeds; the former of which afforded but a moderate crop, the latter a very good one, and has since produced two loads, 120 stones each, per acre. The seeds sown were rye-grass, rib-grass, white clover, and trefoil; of these, the first succeeded amazingly, the others not so well; potatoes throve very well; turnips not equal to them. A farm-house has been built upon it, which now, along with five acres more of the same kind of land, is let on lease at thirty pounds per annum. The soil consisted, in general, of benty peat, upon red gritstone, with a mixture of clay upon limestone; this last is, in some places, at a considerable depth, in others, sufficiently near the surface for lime to be burnt on the premises.

SECT. V. *Of Peat Mosses, Bogs, and Morasses, and their Improvement.*

4183. *Mossy and boggy surfaces* occupy a very considerable portion of the British isles. In Ireland alone there are of flat red bog, capable of being converted to the general purposes of agriculture, 1,576,000 acres; and of peat soil, covering mountains, capable of being improved for pasture, or beneficially applied to the purposes of plantation, 1,255,000 acres, making together nearly three millions of acres. Mossy lands, whether on mountains or plains, are of two kinds; the one black and solid, the other spongy, containing a great quantity of water, with a proportion of fibrous materials.

4184. *Black mosses*, though formerly considered irreclaimable, are now found capable of great melioration. By cultivation, they may be completely changed in their quality and appearance; and from a peaty, become a soft vegetable earth of great fertility. They may be converted into pasture; or, after being thoroughly drained, thriving plantations may be raised upon them; or, under judicious management, they will produce crops of grain and roots; or, they may be formed into meadow-land of considerable value.

4185. *Flow, fluid, or spongy mosses*, abound in various parts of the British isles. Such mosses are sometimes from ten to twenty feet deep, and even more, but the average may be stated at from four to eight. In high situations, their improvement is attended with so much expense, and the returns are so scanty, that it is advisable to leave them in their original state; but where advantageously situated, it is now proved that they may be profitably converted into arable land, or valuable meadow. If they are not too high above the level of the sea, arable crops may be successfully cultivated. Potatoes, and other green crops, where manure can be obtained, may likewise be raised on them with advantage.

4186. *Peat* is certainly a production, capable of administering to the support of many valuable kinds of plants. But to effect this purpose, it must be reduced to such a state, either by the application of fire, or the influence of putrefaction, as may prepare it for their nourishment. In either of these ways, peat may be changed into a soil fit for the production of grass, of herbs, or of roots. The application of a proper quantity of lime, chalk, or marl, prepares it equally well for the production of corn. (*Code.*)

4187. *The fundamental improvement* of all peat soils is drainage, which alone will in a few years change a boggy to a grassy surface. After being drained, the surface may be covered with earthy materials, pared and burned, fallowed, dug, trenched, or rolled. The celebrated Duke of Bridgewater covered a part of Chatmoss, with the refuse of coal-pits, a mixture of earths and stones of different qualities and sizes, which were brought in barges out of the interior of a mountain; and, by compressing the surface, enabled it to bear pasturing stock. Its fertility was promoted by the vegetable mould of the morass, which presently rose and mixed with the heavier materials which were spread upon it. (*Marshal on Landed Property*, p. 46.)

4188. *The fenny grounds* of Huntingdonshire are in some cases improved by applying marl to the surface. Where that substance is mixed with the fen soil, the finer grasses flourish beyond what they do on the fen soil unmixed; and when the mixed soil is ploughed, and sown with any sort of grain, the calcareous earth renders the crops less apt to fall down, the produce is greater, and the grain of better quality than on any other part of the land. (*Huntingdonshire Report*, p. 301.)

4189. *Covering the surface of peat bogs with earth* has been practised in several parts of Scotland. Clay, sand, gravel, shells, and sea-ooze, two or three inches thick, or more, have been used, and land, originally of no value, has thus been rendered worth from 2*l.* to 3*l.* and even 4*l.* per acre. The horses upon this land, must either be equipped with wooden clogs, or the work performed in frosty weather, when the surface of the moss is hard. Coarse obdurate clay (provincially *till*), is peculiarly calculated for this process, as, when it is blended with peat, and some calcareous matter, it contains all the properties of a fertile soil. (*Clydesdale Report*, p. 150, note.) This is certainly an expensive method of improving land, unless the substance to be laid upon it, is within 500 yards distance: but where it can properly be done, the moss thus obtains solidity, and after it has been supplied with calcareous earth, it may be cultivated, like other soils, in a rotation of white and green crops. In the neighborhood of populous towns, where the rent of land is high, the covering substance may be conveyed from a greater distance than 500 yards. (*Code*.)

4190. *Rolling peaty surfaces* has been found to improve them. The greatest defect of soft soils is, that the drought easily penetrates them, and they become too open. The roller is an antidote to that evil, and the expense is the only thing that ought to set bounds to the practice of this operation. It also tends to destroy those worms, grubs, and insects, with which light and fenny land is apt to be infested. The roller for such soils ought not to be heavy, nor of a narrow diameter. If it be weighty, and the diameter small, it sinks too much where the pressure falls, which causes the soft moss to rise before and behind the roller, and thus, instead of consolidating, it rends the soil. A gentle pressure consolidates moss, but too much weight has a contrary effect. A roller for moss ought therefore to be formed of wood, the cylinder about four feet diameter, and mounted to be drawn by two or three men. Three small rollers working in one frame, (*fig. 542.*), have sometimes been so drawn. If horses are employed, they ought to have clogs or pattens, if likely to sink. The oftener the rolling is performed, on spongy soils as long as the crops of corn or grass will admit of it, the better, and the more certain is the result.



4191. *An extensive tract of moss in the county of Lancashire* has been recently improved by the celebrated Roscoe of Liverpool, in a very spirited and skillful manner. Chatmoss in that county is well known; its length is about six miles, its greatest breadth about three miles, and its depth may be estimated from ten to upwards of thirty feet. It is entirely composed of the substance well known by the name of peat, being an aggregate of vegetable matter, disorganized and inert, but preserved by certain causes from putrefaction. On the surface it is light and fibrous, but becomes more dense below. On cutting to a considerable depth, it is found to be black, compact, and heavy, and in many respects resembling coal. There is not throughout the whole moss the least intermixture of sand, gravel, or other material, the entire substance being a pure vegetable. About 1820, Roscoe began to improve Trafford moss, a tract of three hundred acres, lying two miles east of Chatmoss; and his operations on it seem to have been so successful as to encourage him to proceed with Chatmoss. In the improvement of the latter, he found it unnecessary to incur so heavy an expense for drainage as he had done in the former. From observing that where the moss had been dug for peat, the water had drawn towards it from a distance of fifty to a hundred yards, he conceived that if, each drain had to draw the water only twenty-five yards, they would, within a reasonable time, undoubtedly answer the purpose. The whole of the moss was therefore laid out on the following plan.

4192. *A main road*, Roscoe states, "was first carried nearly from east to west, through the whole extent of my portion of the moss. This road is about three miles long and thirty-six feet wide. It is bounded on each side by a main drain, seven feet wide and six feet deep, from which the water is conveyed, by a considerable fall, to the river. From these two main drains, other drains diverge, at fifty yards distance from each other, and extend from each side of the road to the utmost limits of the moss. Thus, each field contains fifty yards in front to the road, and is of an indefinite length, according as the boundary of the moss varies. These field-drains are four feet wide at the top, one foot at the bottom, and four feet and a half deep. They are kept carefully open, and, as far as my experience hitherto goes, I believe they will sufficiently drain the moss, without having recourse to underdraining, which I have never made use of at Chatmoss, except in a very few instances, when, from the lowness of the surface, the water could not readily be gotten off without open channels, which might obstruct the plough."

4193. *The cultivation of the moss* then proceeds in the following manner:—"After setting fire to the heath and herbage on the moss, and burning it down as far as practicable, I plough a thin sod or furrow, with a very sharp horse-plough, which I burn in small heaps and dissipate: considering it of little use but to destroy the tough sods of the eriophora, nardus stricta, and other plants, whose matted roots are almost imperishable.

The moss being thus brought to a tolerable dry and level surface, I then plough it in a regular furrow six inches deep, and as soon as possible after it is thus turned up, I set upon it the necessary quantity of marl, not less than two hundred cubic yards to the acre. As the marl begins to crumble and fall with the sun or frost, it is spread over the land with considerable exactness, after which I put in a crop as early as possible, sometimes by the plough, and at others with the horse-scuffle or scarifier, according to the nature of the crop, adding, for the first crop, a quantity of manure, which I bring down the navigable river Irwell, to the borders of the moss, setting on about twenty tons to the acre. Moss land thus treated, may not only be advantageously cropped *the first year* with green crops, as potatoes, turnips, &c. but with any kind of grain; and as wheat has, of late, paid better to the farmer than any other, I have hitherto chiefly relied upon it, as my first crop, for reimbursing the expense."

4194. *The expense of the several ploughings, with the burning, sowing, and harrowing, and of the marl and manure, but exclusive of the seed, and also of the previous drainage and general charges, amounts to 18l. 5s. per acre; and in 1812, on one piece of land thus improved, Roscoe had twenty bushels of wheat, then worth a guinea per bushel, and on another piece eighteen bushels; but these were the best crops upon the moss. "Both lime and marl are generally to be found within a reasonable distance; and the preference given to either of them will much depend upon the facility of obtaining it. The quantity of lime necessary for the purpose, is so small in proportion to that of marl, that, where the distance is great, and the carriage high, it is more advisable to make use of it; but where marl is upon the spot, or can be obtained in sufficient quantity at a reasonable expense, it appears to be preferable."* Roscoe is thoroughly convinced, after a great many different trials, that all temporizing expedients are fallacious; and "that the best method of improving moss land is by the application of a calcareous substance, in sufficient quantity to convert the moss into a soil, and by the occasional use of animal or other extraneous manures, such as the course of cultivation, and the nature of the crops, may be found to require."

4195. *Roscoe's contrivance for conveying on the marl, seems peculiar. It would not be practicable, he observes, to effect the marling at so cheap a rate, (10l. per acre,) were it not for the assistance of an iron road or railway, laid upon boards or sleepers, and moveable at pleasure. Along this road the marl is conveyed in waggons with small iron wheels, each drawn by one man. These waggons, by taking out a pin, turn their lading out on either side; they carry about 15 cwt. each, being as much as could heretofore be conveyed over the moss by a cart with a driver and two horses.*

4196. *An anomalous mode of treating peat bogs was invented and practised by the late Lord Kaimes, which may be applicable in a few cases. This singular mode can be adopted only where there is a command of water, and where the subjacent clay is of a most fertile quality, or consists of alluvial soil. A stream of water is brought into the moss, into which the spongy upper stratum is first thrown, and afterwards the heavier moss, in small quantities at a time; the whole is then conveyed by the stream into the neighboring river, and thence to the sea. The moss thus got rid of, in the instance of Blair Drummond, in Perthshire, was, on an average, about seven feet deep. Much ingenuity was displayed in constructing the machinery, to supply water for removing the moss, previous to the improvement of the rich soil below. It required both the genius and the perseverance of Lord Kaimes, to complete this scheme; but by this singular mode of improvement, about 1000 English acres have been already cleared, a population of above 900 inhabitants furnished with the means of subsistence, and an extensive district, where only snipes and moor-fowl were formerly maintained, is now converted, as if by magic, into a rich and fertile carse, or tract of alluvial soil. (Code.) In *The General Report of Scotland*, Appendix, vol. ii. p. 38, will be found a detailed account of this improvement.*

#### SECT. VI. *Of Marshes and their Improvement.*

4197. *A tract of land on the borders of the sea or a large river, is called a marsh: it differs from the fen, bog, and morass, in consisting of a firmer and better soil, and in being occasionally flooded. Marshes are generally divided into fresh water marshes and salt water marshes; the latter sometimes called saltings or ings: fresh water marshes differ from meadows, in being generally soaked with water from the subsoils or springs.*

4198. *Fresh water marshes are often found interspersed with arable land, where springs rise, and redundant water has not been carried off; and may be improved by a course of ditching, draining, and ploughing. Where large inland marshes are almost constantly covered with water, or the soil is extremely wet, they may be drained, as large districts in the fens of Lincolnshire have been, and made highly valuable. The object, in that case, is, by embankments, draining, and other means of improvement, to convert these marshes into pasture or meadow, or even arable lands; and where such improvements cannot be accomplished, the most useful woody aquatics, as willows, osiers, &c. may be grown with advantage.*

4199. *Romney marsh* is one of the most extensive and fertile of fresh water marshes in Britain. It contains near 24,000 acres; besides which Walland marsh and Dingle marsh, which are comprised within the walls, contain the former 12,000, and the latter 8,000 acres. Boys informs us that "the internal regulations of these marshes are committed to the superintendance of expeditors. These are appointed by the Commissioners of Sewers, and are to take care that the repairs of the walls are maintained in due order, and that the costs attending the same be levied on each tenant according to the number of acres occupied by him; for which purpose they are to cause assessments to be made out, with the names of the occupiers, and the rateable proportions to be borne by them respectively; and these rates, which must be confirmed by the commissioners, are termed scots; and that when any occupier refuses to pay his scot, the expeditors can obtain a warrant from the commissioners empowering them to distrain for the same, as for any other tax." These marshes are both appropriated to the purposes of breeding and feeding.

4200. *Salt water marshes* are subject to be overflowed at every spring tide, or at other times, when by the violence of the wind, or the impetuosity of the tide, the water flows beyond its usual limits. Their goodness is in a great measure analogous to the fertility of the adjoining marshes; and the extent of them differs according to the situation. Embankments, as it is remarked in *The Code of Agriculture*, are perhaps the only means by which they can be effectually improved, especially when they are deficient in pasture. However, where pasture abounds, they are in some cases more valuable than arable lands, the pasture operating as a medicine to diseased cattle.

4201. *Marshes on the Thames.* In *The Agricultural Survey of Kent* it is asserted, that great profit is made by the renters of marshes in the neighborhood of London bordering on the Thames, from josting of horses, the pasture being deservedly accounted salubrious to that useful animal; for which reason, such horses as have been worn down by hard travel, or long afflicted with the farcy, lameness, &c. have frequently been restored to their pristine health and vigor, by a few months' run in the marshes, especially on the saltings; but as every piece of marsh land in some measure participates of this saline disposition, so do they all of them possess, in a comparative degree, the virtues above mentioned, and for this reason the Londoners are happy to procure a run for their horses, at 4s. or 5s. per week. And another method practised by the graziers in the vicinity of London, is to purchase sheep or bullocks in Smithfield at a hanging market, which being turned into the marshes, in the lapse of a few weeks are not only much improved in flesh, but go off at a time when the markets being less crowded, have considerably advanced in price, and thus a twofold gain is made from this traffick; and as many of the wealthy butchers of the metropolis are possessed of a tract of this marsh land, they have, from their constant attendance at Smithfield, a perfect knowledge of the rise and fall in the markets, and consequently are enabled to judge with certainty, when will be the proper time to buy in their stock and at what period to dispose of them.

4202. *In various districts of the island* that are situated on the borders of the sea, or near the mouths of large rivers, there are many very extensive tracts of this description of land, which by proper drainage and enclosure may be rendered highly valuable and productive. This is particularly the case in Somersetshire and Lincolnshire, as well as that mentioned above. In the former of these counties, vast improvements have, according to Billingsley, as stated in his able *Survey*, been effected by the cutting of ditches, for the purpose of dividing the property, and the deepening of the general outlets, to discharge the superfluous water. Many thousand acres which were formerly overflowed for months together, and consequently of little or no value, are now become fine grazing and dairy lands.

#### SECT. VII. Of Downs and other Shore Lands.

4203. *Downs* are those undulating smooth surfaces covered with close and fine turf met with in some districts on the sea-shore; the soil is sometimes sandy, and at other times clay or loam. In inland situations there are also down lands, as in Wiltshire, Lincolnshire, and Yorkshire; in the two latter counties they are called "wolds."

4204. *Sandy downs on the sea-shore*, are often more valuable in their natural state, than after cultivation. In a state of nature they frequently afford good pasture for sheep and rabbits, and at other times produce grasses that may be used as food for cattle, or as litter. But the great object should be to raise plants which contribute to fix these soils, and to prevent them from being drifted by the winds, which often occasion incalculable mischief. The most suitable plants for the purpose, are the *elymus arenarius*, *juncus arenarius*, *arundo donax*, *ononis communis*, *gallium verum*, *tussilago petasites*, and a variety of other creeping-rooted plants and grasses. Of woody plants, the elder is one of the best for resisting the sea breeze, and requires only to be inserted in the sand in large truncheons. Where the sands on sea-shores are mixed with shells, and not very liable to drift, if they can be sheltered by fences or an embankment, and sown with white clover, it will be found both an economical and profitable improvement.

4205. *Poor sandy soils, in inland districts* are not unfrequently stocked with rabbits. When the production of arable lands are high, it is found worth while to break up these warrens and cultivate corn and turnips; but it frequently happens that taking the requisite outlay of capital, and the expenses and risk into consideration, they do not pay so well as when stocked with rabbits. Such lands are generally well adapted for planting; but in this, as in every other case where there is a choice, circumstances must direct what line of improvement is to be adopted.



4206. *Shores and sea beaches of gravel and shingle*, without either soil or vegetation, are perhaps the most unimprovable spots of any; but something may be done with them by burying the roots of the arenarious grasses along with a little clay or loamy earth. Of these, the best is the *elymus arenarius* (fig. 543 a), already mentioned; and *E. geniculatus* (b), and *sibiricus* (c), would probably succeed equally well. The last grows on the sandy wastes of Siberia, and the preceding is found on the shores of Britain.

## CHAP. V.

### *Of the Improvement of Lands already in a state of Culture.*

4207. *A profitable application of many of the practices recommended in the Chapters of this and the foregoing Book may be made to many estates which have been long under cultivation.* It is certain, indeed, that the majority of those who study our work will have that object more in view, than the laying out or improvement of estates *ab origine*. Few are the estates in Britain in which the farm lands do not admit of increased value, by rectifying the shape of fields, adjusting their size, improving the fences, draining the soil, or adding to the shelter; and few are the farmeries that may not be rendered more commodious. Of this, we shall give a few examples, after recognising general principles and modes of proceeding.

#### SECT. I. *Of the general Principles and Modes of Procedure, in improving Estates already more or less improved.*

4208. *The groundwork of improvement, on which a practical man may tread with safety and full effect, is an accurate delineation of the existing state, together with a faithful estimate of the present value of the lands and other particulars of an estate to be improved.* A general map of the appropriated lands, promptly exhibiting the several farms and fields as they lie, and showing the existing watercourses, embankments, fences, and buildings; the woodlands, standing waters, morasses, and moory grounds; the known mines and quarries; together with the commonable lands (if any) belonging to the estate, forms a comprehensive and useful subject of study to the practical improver. It is to him, what the map of a country is to a traveller, or a sea-chart to a navigator. If an estate is large, a faithful delineation of it will enable him in a few hours to set out with advantages, respecting the connexions and dependencies of the whole and its several parts, with which as many days, weeks, or months could not furnish him, without such scientific assistance. If on the same plan appear the rental value of each field or parcel of land, and the annual produce of each mine, quarry, woodland, and productive water in its present state, the preparatory information which science is capable of furnishing may be considered as complete. And it remains with the artist to study with persevering attention the subject itself, in order to discover the species of improvements of which it is susceptible, and the suitable means of carrying them into effect.

4209. *The species of improvements that are incident to landed property are numerous.* They may, however, be classed under the following heads: the improvement of the outline, and general consolidation of an estate by purchase, sale, or exchange: the improvement of the roads; of the mines and minerals; of the towns, villages, mills, and manufactories; of the waters; of the woods and plantations; and of the farmeries and farm lands. This last subject is the most common, and it is to it that we shall devote the succeeding section. To discuss the other species of improvement, as applied to old estates, would necessarily include so much of what has already passed in review in the foregoing Book, as to be wearisome to the reader.

#### SECT. II. *Of the Improvement of Farmeries and Farm Lands.*

4210. *Farm lands are of more or less value according to the means of occupying them.* Arable lands in particular require buildings and other conveniences, proportioned to the size of a farm. We frequently see tenants curbed in their operations, and incurring a waste of produce, through the want of sufficient homestalls. On the other hand, we sometimes observe a prodigality of expenditure on farm buildings; thus not only sinking money unnecessarily, but incurring unnecessary expenses in subsequent repairs, by extending homesteads beyond the sizes of farms. In some cases, therefore, it will be found necessary to curtail the extent of farm buildings, as large barns; in others to enlarge the yards, and in many to add and re-arrange the whole. The subject therefore may be considered in regard to design and execution; but as we have already treated fully on laying out new farmeries, we shall here offer only a few general remarks as to alterations.

4211. *In improving the plan of a farmery the given intention is first to be maturely considered, and the several requisites to be carefully ascertained.* The given site is next

to be delineated, so as to show the existing buildings, yards, roadways, and entrances; and then, by maturely studying the plan alternately with the site itself, to endeavor to trace out the most suitable alterations; all the while keeping in view the perfection of arrangement, the situation and value of the existing buildings, and the expenses of alteration; returning to the charge repeatedly, until the judgment be fully satisfied. It is much easier to plan and erect a new farmstead, than to improve one which is already erected. The former requires science and ingenuity only; the latter good sense and judgment also.

4212. *In executing improvements on old farmeries* some difficulty occurs as to the incorporation of new and old materials. If the situation and plan are likely to be of permanent approval, the new erections may be made in the most substantial manner; keeping it in view that the old, which are repaired at the time, may afterwards be wholly renewed. But if the repairs and improvements are not to extend further than the duration of a lease, or till, by the expiry of various leases, some general plan of improvement can be determined on, then old materials or less permanent erections may be adopted.

4213. *As an example of adding part of a newly-enclosed common-field to a small anciently enclosed grass-farm (fig. 544.),* we give the following case:

544

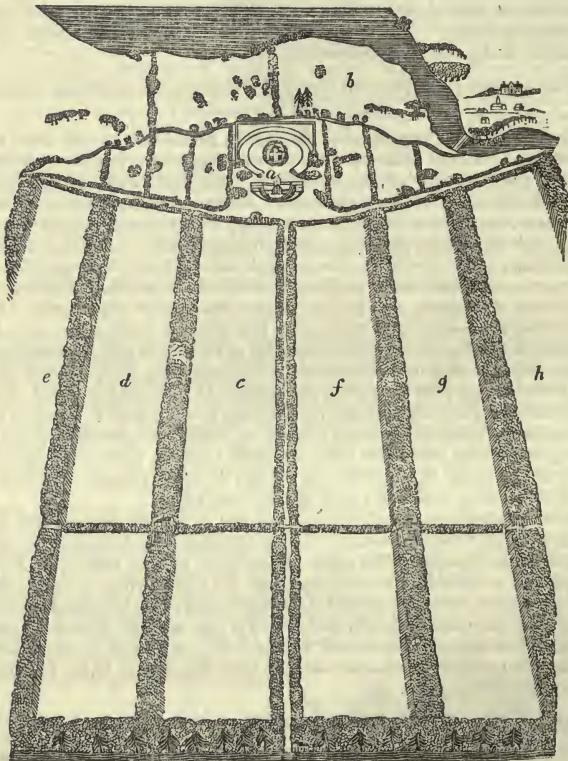

4214. *The farmery (a) and ancient enclosed fields (b),* are separated from the common field by a road, and bounded on the other side by a lake. The soil is a soft black earth on a gravelly subsoil; the surface a gentle slope towards the lake. The farm-house is supposed to be already placed in this ancient part; and the object in view is to unite a large portion of the common field, when enclosed to each ancient farm, so as to get a fair rent for the lands at the least expense. The soil of this common field is a light poor sand, with nearly a flat surface. The circumstances of the country are favorable to large farms, the climate is dry, and the situation such as to require shelter. The number of acres to be enclosed and added to this farm is 1200. These will be most advantageously cultivated in six shifts of, 1, turnips (c); 2, barley (d); 3, artificial grasses (e); 4 and 5, the same (f, g); 6, wheat or oats (h). Each shift is proposed to be separated by a plantation

for shelter, and no inferior divisions are made. In two of the plantations are field-barns, sheds, &c. where the corn grown on one-half of the arable lands is threshed by a moveable threshing-machine, and the straw consumed by cattle. There are cottages at each of these barns for laborers to attend to the stock, &c. The ridges in each of the breaks or shifts are supposed to extend their whole length; or they may be ploughed as if the whole break were only one ridge, by which means not a moment is lost in turning at the ends, &c. Hereford or Devon oxen are supposed the beasts of labor on this farm.

4215. *In place of the above rotation*, wheat may be added after the second year of artificial grasses, and one shift kept entirely under saintfoin. This saintfoin division must of course be changed every sixth or seventh year. However, if a proper mixture of artificial grasses are sown, such as red, white, and yellow clover, rib-grass, burnet, saintfoin, timothy, cocksfoot, rye-grass, and soft grass, the produce will be superior to that from either saintfoin or lucern alone, on a soil such as this, or even perhaps on any soil. Every agriculturist of observation must be aware that the efforts of annual and biennial plants are powerful for a few years at first, and that they uniformly produce a greater bulk than perennials: the latter seem to compensate for this temporary bulk by a steady durable produce.

4216. *The old pasture near the house* is supposed to be irrigated from the upper part of the lake, by a cut passing near the house. These pastures are particularly advantageous for early lambs, milch cows, &c. and for stock in general in seasons of great drought.

4217. *Correcting the outlines of fields* is one of the most obvious sources of amelioration on many, perhaps on most estates. The advantages of proper sized and shaped enclosures have been fully pointed out, when treating of laying out farm lands, and in altering existing fences the same principles must be steadily kept in view; for though, unless by a total eradication of all the existing fences, every requisite may not be attainable, yet such a number may be gained as amply to compensate for the expense. In altering the shape and size of fields, besides the advantages resulting from the improvement in form, it will generally be found that a number of culturable acres may be added to the farm in proportion to the crookedness of the fences and their width. Better drainage and roads will also be obtained, and where ornament is an object, a park-like appearance may be produced by leaving as single trees a part of what may have stood in the eradicated hedge-rows.

4218. *As an example of improving the shape and size of fields*, we shall refer to a farm of 350 acres, situated in Middlesex. (*fig. 545.*) In this case, the fields were larger than



usual, but the fences were in many parts from ten to fifteen yards in width, more resembling strips of copse wood than fences, as they contained hazel, dogwood, black and white thorns, wild roses, brambles, and a variety of native shrubs. The lines of these fences were so ill calculated for carrying off the surface water, that in one half of the fields there were open gutters for the discharge of the water collected in the hedge-row ditches.

4219. In the centre of one field (25), for example, above an acre was rendered waste by the water from other fields (19, 20, and 21), which water, it is curious to remark, might, if led over the same acre agreeably to the principles of irrigation, have produced

annually at least two and a half loads of good hay, in place of annually rendering the produce of this acre unmarketable. The water of some fields (as 16, 18, and part of 19), ran in a diagonal direction through another (15), two acres of which might have been irrigated by it to advantage.

4220. In the farm when altered (*fig. 546.*), the fields are more uniform in shape and size; their sides are parallel, and better adapted for ploughing the lands in straight

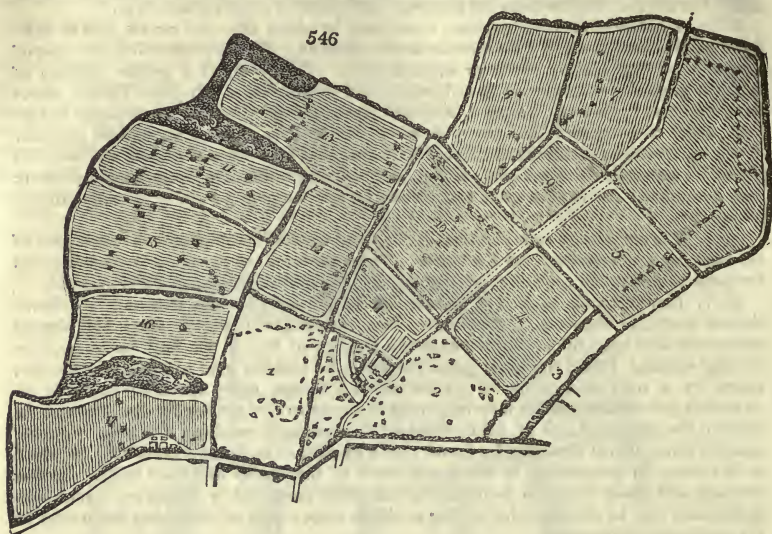

ridges. All the surface-water is carried off by the open fence drains. Access is had to every field by the shortest possible road from the farmery. Only two-thirds the number of gates formerly required are requisite. Fifty acres are rendered useful which were formerly lost, or pernicious, by occupying space for which rent was paid, and by harbouring insects and noxious weeds; and as much rich vegetable earth is obtained from the old hedge banks, as spread abroad in every direction may be said to manure at least ten acres. The whole is more open and healthful; and, from the number of single trees thrown into the fields, more elegant, and bearing a greater resemblance to a park. A part near the house (1, 2, 3) is in permanent pasture, and the rest (4, 5, 6, &c.) under a course of fallow, wheat, clover, beans, wheat.

4221. *As an example of altering the fields and consolidating a farm*, we submit the case of a meadow-farm, with the arable lands in a common field state. (*fig. 547.*) By an act of enclosure, these scattered arable lands (*a*), were exchanged for others adjoining the meadow grounds (*fig. 548 b*), and the whole rendered more compact and commodious. This farm being intersected by a public lane affords an example in which no private roads are wanting. The size and shape of the fields was improved, and the broad fences reduced as in the preceding case, and attended with the same advantages in an agricultural point of view.

4222. *But though in altering broad fences* there are obvious and indisputable advantages to the farmer, yet, as justly observed by Loch, gain is not every thing. "The fences on the Marquess of Stafford's estates," he says, "were liable to the same objection which is applicable to a great proportion of the counties of England. They are not composed of quick, at least but in a scanty degree; they for the most part consist of bushes, growing from the stump of every sort of forest-tree, intermixed with hazel, birch, hornbeam, maple, alder, willow, &c. They are planted on high and dry mounds, and thus are subject to constant decay. They occupy too much ground, provided agriculture alone was the occupation of life. But as they give great protection, when they thrive, to the game, they become an important object of preservation, inasmuch as every thing must be of consequence which contributes to the sport, and has the effect of retaining the gentry of England much upon their estates. For this reason, it may occasionally be proper to consider of the best way to preserve these hedges at the least expense, in place of substituting more perfect ones in their stead; nor should one object exclusively be attended to in the agricultural improvements of so great and so wealthy a country.

4223. *When farm-lands are exposed to high winds*, interspersing them with strips or masses of plantation is attended with obviously important advantages. Not only are such lands rendered more congenial to the growth of grass, and corn, and the health of pasturing animals, but the local climate is improved. The fact, that the climate may be thus improved, has, in very many instances, been sufficiently established. It is, indeed, astonishing how much better cattle thrive in fields even but moderately sheltered than





they do in an open exposed country. In the breeding of cattle, a sheltered farm, or a sheltered corner in a farm, is a thing much prized; and, in instances where fields are taken by the season for the purpose of fattening them, those most sheltered never fail to bring the highest rents, provided the soil be equal with that of the neighboring fields which are not sheltered by trees. If we inquire into the cause, we shall find, that it does not altogether depend on an early rise of grass, on account of the shelter afforded to the lands by the plantations; but, likewise, that cattle which have it in their power, in cold seasons, to indulge in the kindly shelter afforded them by the trees, feed better; because their bodies are not pierced by the keen winds of spring and autumn; neither is the tender grass destroyed by the frosty blasts of March and April. (*Plant. Kal.* p. 121.)

4224. *The operation of screen plantations*, in exposed situations, Marshal observes, is not merely that of giving shelter to the animals lodging immediately beneath them; but likewise in breaking the uniform current of the wind, — shattering the cutting blasts, and throwing them into eddies: thus meliorating the air to some distance from them. Living trees communicate a degree of actual warmth to the air which envelops them. Where there is life there is warmth; — not only in animal, but vegetable nature. The severest frost rarely affects the sap of trees. Hence it appears, that trees and shrubs properly disposed, in a bleak situation, tend to improve the lands so situated, in a threefold way, for the purposes of agriculture: namely, by giving shelter to stock; by breaking the currents of winds; and by communicating a degree of warmth or softness to the air, in calmer weather.

4225. *The proper disposal of screen plantations* for this purpose is in lines across the most offensive winds, and in situations best calculated to break their force. Placed across valleys, dips, or more open plains, in bleak exposures, they may be of singular use. Also on the ridges, as well as on the points, and hangs, of hills.

4226. *The width of screen plantations* ought generally to be regulated by the value of the land for agricultural uses, and the advantages of the situation for the sale and delivery of timber. In ordinary cases, from two to four statute poles may be considered as an eligible width.

4227. *The form of plantations* for shelter, however, will not in every case be that of a stripe or belt of uniform width. In hilly, rocky, and other situations, different forms will suggest themselves according to the situation and the objects in view. In rocky abrupt sites (*fig. 549.*), the plantation will consist of a number of masses (*a, b, c*), of forms determined by the rocks and precipices, among which some of the most valuable pasture may be left as glades (*d, e*), for use, effect, and for the sake of game. Strips and hedges for sheltering, or separating arable lands, should be formed as much as possible in straight and parallel lines, in order not to increase the expense of tillage.

549

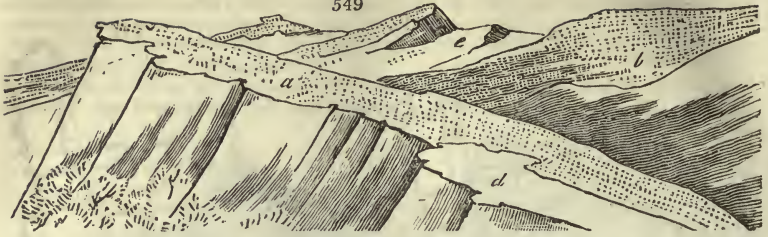

by short and irregular turnings. Straight parallel strips, on irregular surfaces, have a more varied appearance at a distance, than strips ever so much varied on a flat surface; for, in the former case, the outline against the sky is varied as much as that on the earth. In extensive, hilly pastures, in which it is often desirable to produce shelter, and at the same time to plant only the most rocky and unproductive spots, the forms may be of the most irregular description; and by planting chiefly on the eminences and slopes (fig. 550.), shelter will be most effectually produced, the pasture improved, the least valuable ground rendered productive in copse or timber, and the greatest richness and picturesque beauty conferred on the landscape. There are some fine examples of this on the hilly districts of Fifeshire; there, on many estates where nothing was sought for but profit and shelter, the greatest beauty has been produced; and the picturesque tourist now passes through glades and valleys, pastured by well-fed cattle and sheep, enlivened by rocks, thickets, hanging-woods, and occasional rills and lakes. Fifty years ago scarcely a tree was to be seen, and only the most inferior descriptions of live stock.

4228. *The species of woody plants* best adapted for shelter, are the rapid growing and evergreen trees, as the Scotch pine, and such as are at the same time clothed with branches from the ground upwards, as the spruce fir, the best of all trees for shelter, unless the situation is very elevated. Among the deciduous trees, the fast-growing branchy sort are most desirable, as the larch, birch, poplar, willow; in very elevated situations, the birch, mountain-ash, and Scotch-pine, exposed to the sea breeze, the elder and sycamore. To maintain a branchy, leafy screen from the ground upwards, intermix trees and shrubs which stole; or such as grow under the shade and drip of others, as the holly, hazel, dog-wood, box, yew, &c. To produce shelter, and yet admit of the growth of grass below the trees, prune any sort to single stems, and use chiefly deciduous sorts.

4229. In *bleak and barren situations*, Marshal observes, the larch will generally be found the most profitable, as timber. But, being deciduous, it does not in winter, when its services are most wanted, afford so much shelter as the common pine. A skreen, to shelter live stock, should be close at the bottom. It is, otherwise, injurious rather than beneficial. Not only the blast acquires additional current, but snow is liable to be blown through, and to be lodged in drifts on the leeward side, to the annoyance and danger of sheep that have repaired to it for shelter. A larch plantation margined with spruce firs, and these headed at twelve or fifteen feet high, would afford the required shelter, for a length of years. The firs, or pines, thus treated, would be induced to throw out lateral boughs, and feather to the ground: while the larches, in their more advanced state of growth, would, by permitting the winter's winds to pass through the upper parts of the skreen, break the current and mellow the blast.

4230. In *more genial situations*, the beech, by retaining its leaves in winter, especially while it is young, forms a valuable skreen. If the outer margins were kept in a state of coppice wood, and cut alternately, and the middle ranks suffered to rise as timber trees, the triple purpose of skreen plantations might be had in an eminent degree, and almost in perpetuity.

4231. In *deep-soiled, vale districts*, which not unfrequently want shelter, skreens of oak might be managed in a similar way. Hollies, or other hardy evergreens, planted as

550



underwood, in groves of either of the above descriptions, would, if suitable situations were assigned them, assist much in this intention.

4232. *A tall impervious fence* is, for the purpose of shelter to pasturing stock, nearly equal to a depth of coppice wood, and infinitely preferable to an open grove of timber trees; beside its additional use as a fence. There appears, one *species* of fence which is peculiarly adapted to this purpose. This is the coppice mound hedge of Devonshire and South Wales; namely, a high wide bank or mound of earth, planted with coppice woods. This becomes, immediately on its erection, a shelter and a guard to pasture grounds.

4233. *The method of forming fences of this intention* is that of carrying up a stratum of earth, between two sod facings, "battering," or leaning somewhat inward, to the required height; and planting on the top the roots and lower stems of coppice plants, gathered in woods, or on waste grounds; or with nursery plants, adapted to the given situation. If the mound be carried to a full height, as five or six feet, and about that width at the top, and this be planted with strong plants, with stems cut off about two feet above the roots (in the usual practice of Devonshire), a sufficient fence is thus immediately formed against ordinary stock. But if the bank be lower, or if nursery plants be put in, a slight guard, run along the outer brink, on either side, and leaning outward, over the face of the mound, is required (especially against sheep) until the plants get up. If a hedge of this kind be raised as a *plantation fence*, (especially on the lower side of a slope)



the outer side only requires to be faced with sods; the hedge plants being set in a rough shelving bank, on the inner side.

4234. *The species of hedge woods*, proper for mound fences, depends entirely on the soil and situation. On mounds of bad soil, in a bleak situation, the furze alone affords much shelter, and a good fence. The sides being kept pruned, so as to show a close firm face rising above the top of the bank, it is a secure barrier, even against the wilder breeds of Welsh sheep. The beech is commonly planted in high exposed situations; and in places more genial to the growth of wood, the hazel, the ash, and the oak are the ordinary plants of hedge mounds. The willow tribe have a quality which recommends them, in situations where they will flourish: they grow freely from cuttings, or truncheons set in the ground; whereas to secure the growth of ordinary coppice woods, rooted plants are required. The rock-willow (*Salix caprea*) will grow in high and dry situations.

4235. *On thin-soiled stoney surfaces*, tall mounds are difficult to raise; and these *stone walls* are not only built at a small expense, but are convenient receptacles for the stones with which the soil is encumbered. But a stone wall, unless it be carried up to an inordinate height, at a great expense, is useless as a skreen; may be said to be dangerous as such, in a bleak exposed situation, for as soon as the drifting snow has reached the top of the wall, on the windward side, it pours over it, and inevitably buries the sheep which may be seeking for shelter on the leeward side. Hence, in a situation where shelter is required, it is necessary that a stone fence should be backed with a skreen plantation.

4236. *To plant trees for shade* may in some cases be requisite for agricultural purposes. Where this is the case, close plantations are seldom desirable, a free circulation of air being necessary to coolness; therefore trees with lofty stems, and large heads, pruned to single stems are preferable: the oak, elm, chestnut, and beech, for thick shade; the plane, acacia, and poplar, for shade of a lighter degree.

4237. *An example of sheltering a hill-farm by plantation*, and at the same time improving the shape and size of fields, shall next be given. No farming subject affords better opportunities of introducing hedge-rows, and strips of planting than hill-farms. The one under consideration (*fig. 551.*) is a small estate farmed by its owner; it consists of nearly 370 acres; and is situated in an elevated, picturesque part of a central English county. The soil is partly a flinty loam or chalk, and partly a strong rich soil, incumbent on clay. The fields (1 to 34), are very irregular, bounded by strips of timber and copse. By the alterations and additions proposed (*fig. 552.*), all the most hilly and distant spots will be kept in permanent pasture; and the exposed and abrupt places, angles, &c. planted chiefly with oaks for copse, and beech for timber and shelter.

---

## CHAP. VI.

### *Of the Execution of Improvements.*

4238. *The mode in which improvements are executed* is a point of very considerable importance, and may materially affect their success as well as their expense. We shall first consider the different modes of execution, and next offer some general cautions to be held in view in undertaking extensive works.

#### SECT. I. *Of the different Modes of procuring the Execution of Improvements on Estates.*

4239. *The necessary preliminary to the execution of an improvement*, is a calculation of the advantages to arise from it, and an estimate of the expense of carrying it into effect. If the former, taken in their full extent, do not exceed the latter, the proposed alteration cannot, in a private view, be considered as an improvement. The next point to be ascertained is the practicability, under the given circumstances of a case, of executing the plan under consideration. There are three things essential to the due execution of an improvement. 1st, an undertaker, or a person of skill, leisure, and activity, to direct the undertaking; 2d, men and animals with which to prosecute the work; 3d, money, or other means of answering the required expenditure. A deficiency in any one of these, may, by frustrating a well planned work after its commencement, be the cause, not only of its failure, but of time, money, and credit being lost. — Improvements may be executed by the proprietor, either directly, gradually, by economical arrangements, or remotely to ascertain extent, by moral and intellectual means.

4240. *To execute improvements directly*, all that is necessary is to employ a steward or manager of adequate abilities and integrity, and supply him with the requisite plans, men, and money. This will generally be found the best mode of forming new roads, new plantations, opening new quarries or mineral pits, altering the course of waters, and all such creations or alterations as are not included in the improvement of farm lands.

4241. *To procure the gradual execution of improvements on farm lands*, various arrange-

ments may be made with the tenants: for example, by granting long leases; letting them find the requisites of improvement, and take the advantages during their terms; by granting shorter leases, with a covenant of remuneration for the remainder of such improvements as they have made, at the time of quitting; by granting leases, at a low rent, for the first years of the term, to give the tenants time and ability to improve at their own expense; by advancing money to tenants at will, or, which is the same, making allowances of rent for specified improvements, to be executed by them under the inspection and control of the manager, they paying interest for the money advanced, or allowed; by employing workmen on tenanted farms; the tenants in like manner paying interest on the money expended. The usual interest, till lately, was six per cent.; thus estimating the value of the improvement at sixteen years purchase.

4242. *The moral and intellectual means of improving farm lands* consists, as Marshal has observed, in enlightening the minds of tenants. Though this mode is but of slow operation, and respects more improvements in modes of culture, than such as require great outlay; yet it deserves notice in this place, as necessary to second the efforts of the landlord.

4243. *Farmers, as moral and intellectual agents,* may be divided into reading men, and illiterate beings; the first class derive hints for improvement from books; but the second can only, if at all, derive benefit from example.

4244. With respect to *improving farmers by books*,—agricultural newspapers, magazines, and county surveys, are probably what would be read with most eagerness, and as such works abound in statements of what actually has taken place in different situations, by farmers like themselves, perhaps they are the most likely to stimulate to exertion. Historical relations of the agriculture of other countries are also generally interesting to agriculturists, and though no great professional benefit is to be derived from them, yet they tend to enlarge and liberalize the mind, and promote a taste for knowledge. Under these circumstances it may be worthy of consideration whether an agricultural library might not be established in the steward's office of very extensive estates for the use of the tenants and all other persons belonging to the estate who chose to read from it.

4245. *The establishment of schools* for the children of the lower class of tenants, and of cottagers of every description, is an obvious and important source of moral and intellectual improvement; and considering it as decided by experience and the most competent judges, that the education of the lower classes will tend greatly to their amelioration and the benefit of society at large, we are of opinion that wherever they are not already established, they should be introduced. Working schools, somewhat in the German manner (343.), both for boys and girls, would also be a material improvement in such districts as are behind in a taste for cleanliness, fire-side comforts, cookery, and dress.

4246. *Examples as stimuli to improvement* may be exhibited in various ways; by letting a farm to a tenant of superior energy, or from a more improved district; by exhibiting improved implements and operations on one particular farm; by an itinerant ploughman of abilities, accompanied by a smith and carpenter, and with some implements, to go round the estate and instruct each tenant on his own farm; and finally, and perhaps preferably, by inducing every farmer to make a tour into some other district once a year.

4247. *In addition to these modes*, appropriate as we consider for two different classes of tenants, Marshal suggests the following as calculated to insure a spirit of improvement among all farmers not of sufficient energy and intelligence. They are to be adopted by a proprietor, or by the manager of an estate, who has a knowledge of rural affairs, and who possesses the good will and confidence of its tenantry, in various ways.

4248. *By personal attention only* much is to be done. By reviewing an estate, once or twice a year; by conversing with each tenant in looking over his farm; and by duly noticing the instances of good management which rise to the eye, and condemning those which are bad; vanity and fear, two powerful stimulants of the human mind, will be roused, and an emulation be created among superior managers; while shame will scarcely fail to bring up the more deserving of the inferior ranks. If, after repeated exhortations, an irreclaimable sloben be discharged as such, and his farm given to another, professedly for his superior qualifications as a husbandman, an alarm will presently be spread over the estate, and none, but those who deserve to be discharged, will long remain in the field of bad management.

4249. *Even by conversation*, well directed, something may be done. If, instead of collecting tenants to the audit, as sheep to the shearing, and sending them away, as sheep that are shorn;—or if, on the contrary, instead of providing for them a sumptuous entertainment, and committing them to their fate, in a state of intoxication;—a repast, suited to their conditions and habits of life, were set before them;—and if, after this, the conversation were to be bent towards agriculture, by distributing presents to superior managers, specifying the particulars of excellence, for which the rewards or acknowledgments were severally bestowed;—a spirit of emulation could not fail to take place among

the higher classes; while the minds of the lower order of tenants, and of the whole, would be stimulated and improved by the conversation.

4250. *By encouraging leading men*, in different parts of a large estate, — men who are looked up to, by ordinary tenants; — by holding out these as patterns to the rest; — by furnishing them with the means of improving their breeds of stock; by supplying them with superior varieties of crops, and with implements of improved constructions: and, in reclude and backward districts, much may be done by tempting good husbandmen, and expert workmen, from districts of a kindred nature, but under a better system of cultivation, to settle upon an estate.

4251. *By an experimental farm*, to try new breeds of stock, new crops, new implements, new operations, and new plans of management; such as ordinary tenants ought not to attempt, before they have seen them tried. To this important end, let the demense lands of a large estate, or a sufficient portion of them, be appropriated to a nursery of improvements, for the use of the estate; to be professedly held out as such, and be constantly open to the tenants; more particularly to the exemplary practitioners, the leading men of the estate, just mentioned; who, alone, can introduce improvements among the lower classes of an ignorant and prejudiced tenantry: it is in vain for a proprietor to attempt it. On the contrary, the attempt seldom fails to alarm, disgust, and prevent the growth of spontaneous improvements.

4252. *Under the present plan of demense farming*, the tenants see expensive works going forward, which they know they cannot copy, and hear of extraordinary profits, by particular articles, which they are certain cannot be obtained by any regular course of business. They therefore conclude that the whole is mere deception, to gain a pretext for raising the rents of their farms above their value. Whereas, if the demense lands were held out, as trial grounds, for their immediate benefit, and conducted, as such, in a manner intelligible to them, they would not fail to visit them. Instead of large proprietors attempting to rival the meanness of their tenants, in farming for pecuniary profit, which, on a fair calculation, they rarely, if ever, obtain; let their views in agriculture be professedly and effectually directed toward the pecuniary advantages of their tenants: for from these, only, their own can arise, in any degree that is entitled to the attentions of men of fortune. Instead of boasting of the price of a bullock, or the produce of a field, let it be the pride of him who possesses an extent of landed property, to speak of the flourishing condition of his estates at large, the number of superior managers that he can count upon them, and the value of the improvements which he has been the happy means of diffusing among them. Leave it to professional men, to yeomanry and the higher class of tenants, to carry on the improvements, and incorporate them with established practices; to prosecute pecuniary agriculture in a superior manner, and set examples to inferior tenantry. This is strictly their province; and their highest and best view in life. It has been through this order of men, chiefly or wholly, that valuable improvements in agriculture have been brought into practice, and rendered of general use.

4253. *The possessor of an extent of territory has higher objects in view*, and a more elevated station to fill. As a superior member of society, it may be said, he has still higher views than those of aggrandizing his own income. But how can a man of fortune fill what may well be termed his legitimate station in life, with higher advantage to his country, than by promoting the prosperity of his share of its territory; by rendering not one field, or one farm, but every farm upon it productive? This is, indeed, being faithfully at his post. And it is a good office in society which is the more incumbent upon him, as no other man on earth can of right perform it; valuable as it is to the public.

## SECT. II. *General Cautions on the Subject of executing Improvements.*

4254. *No work can be prudently commenced until the plan be fully matured*, not in idea only, but in diagrams, and in models, if the subject require them; in order that every bearing, and every hinge, may be sufficiently foreknown: the site of improvement being reverted to, again and again, with the draught or the model in hand; until the judgment be satisfied, and the mind be inspired with confidence. If a proprietor has not yet acquired sufficient judgment, within himself, let him consult some one man, or one council of men, in whose knowledge and judgment he can confide; and thus fix a rallying point. Having brought his plan to a degree of maturity, in this private manner, he may then venture to publish it; and endeavor to improve it, by the advice of its friends, and the animadversions of its enemies.

4255. *If a proprietor wants judgment himself, and a friend to supply it*, let him not attempt the more difficult works of improvement. Yet how often we see, both in public and private life, men engaged in arduous undertakings, embarked on the wide ocean of business, without rudder or compass to guide them: depending on casual information, to help them on their way: sponging, with porous brain, the minds that are bedewed with the knowledge they require. But having no store of their own to assimilate it with, it presently evaporates. They are consequently ever of opinion with the last persons they converse with. Such men's decisions and operations are always wrong: and for an obvious reason. They consult those who are best able to inform them, first: and receive their last impressions from those who are least capable, to give them. Men who have neither judgment in themselves nor any standard of practice to rally at, are liable to be led astray by the plausible schemes of theorists, the greater part of whom know nothing of the practical part of business; and by their calculations both of expense in the outlay, and of profit in the return, deceive both themselves and their friends or employers; some also may have sinister designs in view; though we believe the errors of speculative men are in most cases owing to their being endowed with more of the imaginative than of the judging faculty.

4256. *The execution of the different improvements*, of which an estate has been found susceptible being determined on, it is always advisable to begin with one which is obvious; which may be effected with the greatest certainty; which will repay most amply the expenses of carrying it into effect: or which leads to other improvements; as embankment, drainage, &c. To attempt a doubtful project, while plans which are obvious and certain, remain unexecuted, to try experiments before the list of known improvements has been gone through, is seldom to be recommended; though it might sometimes turn out to be right.

4257. *All rural operations are more or less public*, and as it were performed on a stage; and spectators fail not to criticise. If an experiment should prove abortive, or a proposed improvement turn out to be false, the ardor of the improver will be liable to be damped, his people to be discontented (as partaking in the discredit), and the expecting public around him, to be disappointed. A few miscarriages, in the outset, might frustrate the best intentions, and the most profitable schemes. But if, by prosecuting plain and certain improvements, a man once gain his own confidence, as well as that of the people about him, he may then venture to explore less beaten paths. And this he will be able to do with greater caution, and more probability of success, by the experience that he has already gained: this being a further motive for pursuing the line of conduct here suggested.

4258. *All works of improvement should be executed with vigor*. Many falter in the midst of well planned works, either through the want of foresight or of business-like exertion, in consequence the money already expended lies dead, and the works are injured by the delay. Some works, as embankments and drainages, may be ruined by the slightest neglect or relaxation, and indeed, as Marshal observes, we see in every department of the kingdom, these and other works deserted and left to moulder into nuisances or disreputable eyesores.

4259. *In carrying on a work, execute every thing substantially, and in a workman-like manner*. Too often a false economy leads to the subversion of this principle. To save a few pounds in the first cost, materials of an inferior quality are laid in, or an insufficient quantity used, to give the required substance and strength to the work. By either of these imprudences, its duration is abridged; and the eventual loss, by repairs and renewal, may be ten times greater than the sum injudiciously saved in the original erection. Nevertheless, to increase the evil of these ill-judged savings, inferior workmen are employed, or sufficient workmen at inferior prices, at which they cannot afford to make good work; nor can a superintendant urge them to make it under such circumstances. Consequently the work is ill performed, its duration is still more abridged, and a further loss, by injudicious saving, is incurred.

4260. *There are cases in which temporary works only are required*. A lease-tenant, for instance, wants to make an improvement which will last as long as his lease, without caring about its further duration. In such a case, it may be well-judged frugality and admissible "cleverness in business," to work up cheap materials in a cheap way. But it seldom can be right in the proprietor of an hereditary estate, whose interest in it may be said to be perpetual, to proceed in the same manner. His best policy is to take favorable opportunities of laying in good materials at moderate prices, to use them when duly seasoned, and to employ good workmen at fair prices, such as cannot furnish them with an excuse for being guilty of bad workmanship, and such as will warrant their employer to urge and enforce that which is good.

4261. *Accomplish one work before another is commenced*. A work may be considered as accomplished when the chief difficulties are surmounted, and cost expended; and till this is the case, it cannot be prudent to embark in another. By avoiding embarrassments, the execution of improvements becomes a present pleasure, as well as a source of future profit. No half-finished works are left as monuments of disgrace to an estate and its owner. No time nor interest of money is lost. Every work is brought into action and profit as it is finished; and if, as it frequently will happen with the most prudent calculators, it has exceeded the estimated sum which was set apart for it, due time may be taken to let the fund of improvement accumulate, so as to enable it to discharge the arrear, and to furnish, as they may be wanted, the estimated sums which the succeeding work may require.

---

## BOOK IV.

### OF THE MANAGEMENT OF LANDED PROPERTY.

4262. *The management of an extensive landed estate*, like that of every other great property, is a business both of talent and integrity. In former times, when every proprietor

may be said to have cultivated the whole of his agricultural territory, it constituted his whole occupation, when not engaged in war; or required a host of managers if he was a man of the first rank. On the continent, and especially in Russia and Hungary, where estates are of enormous extent, and wholly farmed by the proprietor, the largest estates, as we have seen (609.), are managed by a court of directors, and an executive department, with a numerous body of superintendant officers, artists, and artisans. A better system is now adopted in this country, in consequence of the creation of professional farmers, who, taking large portions of territory from the owner for a certain number of years at a fixed rent, and on certain stipulations, for mutual security, occasion little more trouble to the proprietor, during that period, than receiving payments. Hence it is, that the management of estates in Britain, though important, is a more simple business than in any other country.

4263, *Where there are only tenanted holdings*, the business of management is very simple; where there are woodlands, it requires a person to look after that department; and where there are waters, quarries, and mines, a greater number of subordinate officers are requisite. But what often occasions most expense, and at the same time is attended with the least profit, is the management of the abstract rights belonging to an estate; such as tithes, manorial rights, quit-rents, and other antiquated trifles, which require courts to be holden, and lawyers and other officers to be called in to assist. The only British author who has digested the business of managing estates into a regular system, is Marshal, and we shall follow him in considering this subject: — 1st, As to the superintendants on the executive establishment of an estate; and 2d, As to the general business of management.

---

## CHAP. I.

### *Of the Superintendants, or Executive Establishment of an Estate.*

4264. *Though every man who cannot manage his own estate in all important matters, deserves to lose it*; yet as extensive proprietors generally have their properties situated in different parts of the country, and have besides public duties to attend to, certain subordinate managers become necessary. In *The Code of Agriculture*, it is stated, that no individual having a large estate is equal to the task of managing it, unless he is in the prime of life, dedicates his whole time to the business, and gives up every other occupation. It is there stated to have been found expedient by the proprietor of an estate of great extent, to nominate two or three commissioners to assist him in its management. Under the superintendance of such commissioners, it is said, the affairs of a great property would be as well conducted, as on the best managed small or moderate sized estates; while the duties of the proprietor would principally be to carry these exercises of true benevolence into effect, which would consist in softening severe decisions; or in granting those marks of approbation and reward which, when bestowed by the proprietor himself, are the most likely to produce beneficial consequences. (*Code, &c. App. 58.*) Such may be the case on a few estates in the British isles not yet brought into a regular system of improvement, and about to be remodelled, of which a grand example occurs in the immense property of the Marquess of Stafford; but in the great majority of cases, a manager to each separate estate, of qualifications suited to its extent and duties, and a general receiver and controller in the capital or metropolis, (if the proprietor and his banker cannot effect these duties between them,) are all that is requisite. We shall first offer a few remarks on the qualifications and duties of managers, and next on the place of business and its requisites.

### SECT. I. *Of the Steward or Manager of an Estate, and his Assistants.*

4265. *The head manager of an estate ought unquestionably to be the proprietor himself, or his representative, if a minor or otherwise incompetent.* Next to the proprietor is his acting man of business, with proper assistants; together with such professional men as the circumstances of business may render necessary as advisers. A tenanted estate differs widely from other species of property; as giving power and authority over persons as well as things. It has, therefore, a dignity, and a set of duties, attached to it, which are peculiar to itself. A man who receives ten thousand pounds a year from the public funds, for instance, is an insulated being, compared with him who receives the same income from landed property; who is one of society's best members: provided his affairs are judiciously conducted. On the contrary, if, regardless of the dignity and the duties of his station, he lives but to dissipate his income, leaving the government of his estates and their inhabitants, to those whose interest and honor are unconcerned in their welfare, or to those whose best interests lie in their derangement, he becomes at once



an enemy to himself, to his family, and to the community. As unpardonable it would be in the possessor of a kingdom to be ignorant of state affairs, and unmindful of the ministers who reside about his court; — or in the commanding officer of a regiment to be a stranger to his men, — a priest to his parishioners, — or a shepherd to his flock; — as for the possessor of a tenanted estate to be ignorant of territorial concerns, and a stranger to his lands and their occupiers.

4266. Though it be an *essential part of the duty of a man of fortune to be intimately acquainted with his own affairs*, it does not follow that he should be absorbed in them, and neglect his duties as a superior member of society. In all matters of government and command, subordination is essential to good order and success. A commander in chief does not act as pioneer, nor does a naval commander reef his sails, or heave his anchor. Each has his subordinate officers to convey his commands, and men to execute them. But it is essentially necessary that the former should be well acquainted with military, the latter with naval affairs. Every heir apparent, therefore, to a large landed property, should be regularly, or at least more or less, bred up in the knowledge of rural affairs, so as to fill with honor and profit the high station he has in view. But if the possessor of an estate has not been fortunately initiated in the knowledge which belongs to his station, the task of acquiring it is far from great.

4267. *On a large estate we generally find a resident manager*, a land steward, a man who has some knowledge of what is termed country business, and who acts under the control of his employer, or of a confidential friend, who is more conversant in rural concerns; or perhaps of a law agent, who knows less of them; or such residing steward, especially of a detached estate which lies at some distance from the residence of its proprietor, acts without control. In the last case, if he is a man of judgment, it is fortunate both for the landlord and tenant. But, on the contrary, if such possessory manager wants those requisite qualifications, the consequence becomes mischievous to the lands, their occupiers, their proprietors, and the community.

4268. *The requisite acquirements of an acting manager*, according to Marshal, are a knowledge of agriculture, surveying, planting, some knowledge of mechanics, natural history, and a master of accounts. Agriculture is the only firm foundation on which the other required attainments can be securely reposed. It is not more essentially valuable in the superintendance, than in the improvement of an estate. It is difficult to become an accurate judge of the value of lands without a practical knowledge of their uses; nor can any man without it, properly appreciate the management of occupiers, much less assist them in correcting their errors, and improving their practice.

4269. *Land-surveying* is a requisite qualification. Not so much however, for the purpose of measuring and mapping an estate, at large, as for checking and correcting the works of professional men, as well as to assist in laying out its lands to advantage.

4270. *Planting*, and the management of woodlands, are acquirements that cannot be dispensed with. Nor should his knowledge and attention be confined to the surface of the estate entrusted to his care; he ought to have some acquaintance with natural history, chemistry, and experimental philosophy, to enable him to form just notions on the subject of the subterrene productions which it may contain.

4271. *Some knowledge of mechanics*, and other sciences that are requisite to the business of an engineer, may be highly useful in prosecuting the improvements incident to landed property.

4272. A competent knowledge of *rural architecture*, the doctrine of the strength of materials, and the superintendance of artificers, may be said to be of daily use.

4273. *A thorough knowledge of accounts* is essentially requisite to the manager of a landed estate.

4274. He should be a *man of good character, of upright principles, and conciliatory manners*; to set an example of good conduct to the tenants, and to become their common counsellor and peace-maker, in those trifling disputes which never fail to arise among the occupiers of adjoining land; and which too frequently bring on serious quarrels and lawsuits, that end in the ruin, not only of themselves, but of the tenements they occupy. A proprietor has, therefore, an interest in checking such disputes in the bud. And no man can do this with so much effect, as a manager in whom they have a proper confidence; and who possesses a due share of popularity on the estate.

4275. *The acting manager requires certain assistants* on a large estate; especially if it lies in a detached and scattered parts. Those in general use, are a ground officer and clerk.

4276. *A land-reeve, woodward, or ground officer*, is required on each district or department of a large estate; to attend, not only to the woods, and hedge-timber, but to the state of the fences, gates, buildings, private roads, driftways, and watercourses; also to the stocking of commons (if any), and encroachments of every kind; as well as to prevent, or detect, waste and spoil, in general, whether by the tenants of the estate, or others; and to report the same to the manager.

4277. *The office clerk, book-keeper, or under steward*, is employed to form registers, make out rentals, &c. and keep the accounts of the estate; as well as to assist the manager in his more active employments; also to act as his substitute in case of sickness, or absence; and to become his successor in the event of his death, or other termination of his stewardship.

4278. *A law assistant, solicitor, or attorney*, may next be considered as requisite to the good management of a landed estate. For although much is to be done by judicious regulations, and the timely interposition and advice of a resident manager, such are the

frailties of human nature, that, in a state of civilised society, and of property, legal assistance will sometimes be necessary. The error of country gentlemen consists, not in employing lawyers, but in committing the management of their landed estates to them.

4279. *In the feudal system*, under which every manor court was a court of law, we may perceive the origin of law land-stewards. It is allowed by the best agricultural writers in Europe (*Chateauvieux, Thaer, Thóuin, Sigismondi, Jovellanos, Young, Marshal, Brown, Coventry, &c.*), that these men by their rigid adherence to precedent in the clauses of leases, have contributed most materially to retard the progress of agricultural improvement.

4280. *The land-surveyor* is another professional man, whom the superintendent of an estate may want to call in occasionally. Not merely to measure and map the whole or parts of the estate, but to assist in matters of arbitration, and the amicable settlement of disputes; or to act himself, as valuer or referee.

#### SECT. II. *Of the Land Steward's Place of Business, and what belongs to it.*

4281. *A manager's place of business* may be considered in regard to its situation, accommodation, and appropriate professional furniture.

4282. *The situation* of the place of business should be under the roof of the proprietor's principal residence; round which, and in its neighborhood, some considerable parts of his estates may be supposed (as they ever ought) to lie. If a large bulk of his property lie at too great a distance for tenants to attend at the principal office, and on which he has a secondary residence, an inferior office is there required for such detached part. And it may be laid down as a rule, in the management of landed property, Marshal observes, that every distant part of an estate ought to have a place upon it (be it ever so humble) in which its possessor may spend a few days comfortably; to diffuse over it a spirit of good order and emulation. He has known the most neglected and almost savage spot, such as are many landed estates in Ireland, reclaimed and put in a train of improvement by this easy method.

4283. *The accommodation* requisite for a principal office, are a commodious business room, a small anti-room; and a safe-keep, or strong room fire proof, for the more valuable documents.

4284. *The professional furniture* with which an office of this description requires to be supplied are maps, rental-books, books of valuation, register, legal papers, and some others.

4285. *A general map* of the whole estate on a large scale is an obvious requisite; and portable separate maps, with accompanying registers and other descriptive particulars, are useful in proportion as improvements may be in contemplation.

4286. *Books of valuation* are essential, especially where there are numerous small holdings on short terms. In these registers is contained the number, name, admeasurement, and estimated value of each field, and every parcel of land, as well as of each cottage, or other building, not being part of a farmstead, on the several distinct parts or districts of the estate. The valuations being inserted in columns, as they arise, whether by general surveys, or incidentally; headed with the names of their respective valuers, so that whenever a farm is to re-let, these columns may be consulted, and its real value be fixed, in a re-survey, with the greater exactness.

4287. *A general register of timber trees, copsewood, and young plantations* is particularly wanted where there is much hedge-row timber. Marshal directs to specify in this register the number of timber trees in each wood, grove, hedge-row, and area, with the species, number, and admeasurement of each tree. He also recommends separate pocket-books, containing the particulars of each division, or of a number of contiguous divisions, for the occasional use of the manager and wood-reeve.

4288. *Contracts, agreements, accounts, letters on business, and other documents*, should be intelligibly endorsed, dated or numbered, and arranged so as to be easily referred to. A book of abstracts, or heads of papers of greater importance, should be made out to be referred to on ordinary occasions; and likewise to serve as an index to the originals, which require a more secure repository than a common business-room.

4289. *Legal documents*, such as title deeds, legal decisions, awards of arbitration, counterparts of leases, securities, cash, bills, passed accounts, &c., as being the most important objects, should be carefully deposited in the safety-chest or strong room.

4290. *Portable registers* of the tenanted lands in convenient pocket volumes, with maps on a small scale heading every farm, are a most invaluable description of books both for the manager and his employer. Two opposite pages being appropriated to each farm with its map, the following information should be given:—

Name of the farm and its number of acres.  
 The name of the tenant and the existing rent.  
 The tenancy; if on lease, the term of expiring.  
 Any extraordinary covenant of the lease.  
 The number of cottages let with the farm.  
 The number of timber trees growing on it.  
 The number of orchard trees growing on it.

The eligibility of the plan and circumstances of the farm.  
 The eligibility of the occupier.  
 The eligibility of the present rent.  
 The state of the buildings, fences and gates, roads, and watercourses.  
 The state of cultivation, and condition of the live stock.

4291. *Add, among other things, the following, viz.*

The repairs more immediately wanted.  
 The improvements of which the whole is susceptible.  
 The agreements entered into with the tenant.  
 The permissions granted him.  
 The injunctions delivered to him.  
 With a hint as to his personal character, and the number and general character of his family.

With any other incident or occurrence respecting the farm or its occupier, that requires to be remembered; and with references to the books and papers which may pertain to the several particulars; thus having at one view a complete abstract of the history and present state of every farm, together with the particulars of attention which each will require.

4292. *The trouble of forming an abstract of this kind, or of renewing it, when filled, or in order to adapt it to the varying circumstances of the several farms, is inconsiderable, compared with its uses; which are not only obvious to theory, but are fully established in practice.* On returning to an estate, after twelve months' absence, Marshal has generally found, that, by consulting a register of this sort, and, through its means, making systematic enquiries respecting the incidents that have occurred on the several farms during his absence; he, in this summary way, and before he entered upon a fresh view, became better acquainted not only with the general interests but with the more ordinary business, of the estate, than the acting manager, who had constantly resided upon it, without such a remembrancer. This abstract or remembrancer, he says, ought not to comprehend tenanted farms only; but should comprise woodlands, quarries, the demesne, &c., in hand; as well as the more important improvements going on: each of which ought to have its separate folio assigned it. To a proprietor, or his confidential friend, who only goes over his estate occasionally, such an intelligent companion is essentially serviceable. He cannot profitably direct, nor safely advise with, an acting manager, or other agent or officer of the estate, until he has consulted so infallible an oracle. The utility of such a register, while a proprietor is absent from his estate, if he can be said to be so, with such a faithful mirror in his possession, is too obvious to require explanation.

4293. *Among the instruments necessary for a manager's office, may be included those requisite for surveying, mapping, levelling, measuring timber, and every description of country work; together with boring machines, draught measurers, weighing scales, some chemical tests, models, and such other articles as may be required or rendered useful by particular circumstances.*

4294. *An agricultural library may be considered an essential requisite; including works on rural architecture, the prices and measuring of work, and other fluctuating matters; and one of the best Encyclopædia's of universal knowledge. We have already (4243.) suggested an important use to which such a library might be applied.*

4295. *Such an establishment and place of business as has been described, we agree with Marshal in thinking many will consider as in some degree superfluous or extravagant. In many cases we admit it would be so; but it is impossible to be determined what things can be done without, unless a particular case were given. Such a minute register of farms, for example, would be quite ridiculous on an estate in East Lothian, where tenants are of sufficient wealth and respectability of manners to be treated as men; and not watched and schooled like those which Marshal seems generally to have in view.*

## CHAP. II.

### *Of the Duties of Managers of Estates.*

4296. *The various duties of the manager, or the proprietor of a landed estate, may be considered under the heads of general business, business with tenants, and auditing accounts.*

#### SECT. I. *Of the general Principles of Business considered relatively to Land-Stewardship.*

4297. *The first and most general principle, in this and every other department of business, is to embrace readily the several matters as they occur: and not, on the contrary, to put them off from time to time, until they accumulate; and render the task of transacting them difficult and irksome. The only artifice, it may be said, which a man of character can well employ in business, is that of endeavouring to render it pleasurable. And, by meeting it cheerfully, as it rises, or as it becomes ripe for dispatch,*

this desirable end will generally be obtained. For, in that state a man not only enters upon it with pleasure himself, but he will generally find his opponent in the same temper of mind. Whereas through delay, misunderstandings, idle tales, and groundless surmises, are liable to intervene; the minds of both to be soured; a distant coolness to take place between them; and a barrier to be raised, which, though altogether imaginary, nothing but the mystic wand of the law may be able to remove.

4298. *There are three distinct methods of conducting business.* The first is that in which the parties meet, with fair intentions, to find out the point of equity, and there to close. In the second, they enter upon business, guarded with cunning, and armed with trick and artifice, as gamblers draw round a table, to take every advantage, fair or otherwise, which they can effect with impunity. The last method lies in the courts of law and equity.

4299. *A business founded on honorable intentions* is the only one in which a man of honor can voluntarily appear. Here honest men come as indifferent persons to arbitrate the matter in reference. In every settlement between man and man, there is a point of equity and right, which all good men are desirous to find; and when men of liberal minds fortunately meet and join in the search, it is seldom difficult to be discovered. Should some little difference of opinion arise, let them call in an umpire to decide between them; or leave the whole to the decision of three capable and disinterested men.

4300. *A man of strict integrity may become entangled in business with a man of looser principles.* In this case, it behoves him to be upon his guard; but still to enter into the negotiation with temper and civility. There is even a politeness in affairs of business which cannot be departed from on any occasion. Interruptions and schisms frequently arise, especially between men who are of keen sensibility, and who (though passably honest) are tenacious of their own interests, from mere matter of punctilio. The mind of either being once soured by neglect, or ruffled by disrespectful behaviour, the smooth path of peaceful negotiation is broken up, a spirit of warfare is roused, and advantages are taken, or attempted, which calm reason would not have suggested. Hence, when men of unequal degree are brought together in business, it is incumbent on the superior to set the example of liberality and civility of demeanor.

4301. *In extreme cases* there is no resource but the law; and here the most that an honest man can do is to procure, without loss of time, the best advice; and to spare no exertion or useful expense in bringing the dangerous and tormenting business to a speedy conclusion. Not only is a man's property endangered, while it is tossed on the troubled sea of the law; but his time and attention are led astray; and his peace of mind is liable to be broken in upon; thus deranging his ordinary concerns, and disturbing the stream of life. How much legal disputation might be prevented by a timely attention to business!

4302. *In forming connections in business, select the man who has a character to lose.* This principle should be invariably acted on. For if a man of established good character be properly treated, and determinately closed in with, in case he demur, or swerve from the right line of conduct, he will not forfeit his good name by doing a disreputable action; and must therefore come forward to the point of equity and justice.

## SECT. II. *Of the Management of Tenants.*

4303. *The general treatment of tenants and cottagers* may be considered as the most important part of every land-steward's occupation: it includes the mode and conditions of letting lands; and the time and manner of receiving rents.

### SUBSECT. 1. *Of the proper Treatment of Tenants.*

4304. *On every large hereditary estate, there are established customs and usages, to which the proprietor and the occupiers consider themselves mutually amenable, though no legal contracts may subsist between them.* Even where imperfect leases, or other legal agreements exist, still there is generally much left for custom and usage to determine. Though some of these may be improper, yet they ought to be strictly observed by its superintendent, until better can be placed in their stead; not merely on the score of moral justice, but, in the same observance, to set an example of integrity and good faith to the tenants. If a superintendent imprudently break through a custom or a covenant, what can he say to a tenant who follows his example?

4305. *A manager ought to set an example to the tenants* under his care, of liberality and kindness. This is more especially applicable to the case of cottagers and others who rent small holdings. There are numberless small favors which he can bestow upon them without loss, and many with eventual advantage to the estate. A spirited improving tenant should be refused nothing that he can reasonably ask — should have favors voluntarily conferred upon him; not merely as a reward for the services which he individually is rendering the estate, but to induce its other tenants to follow his

example, and to make known to the whole that their conduct is observed, and distinctions made between good and bad managers.

4306. *Estates, like men, have their good and bad characters.* No skilful farmer who has a capital to lose, will take up his residence on an estate of known bad character. On the contrary, when once an estate has acquired the character of good faith and proper treatment of its tenantry, men of money and spirit will ever be anxious there to gain a footing. Beside, the character of an estate will ever involve that of its possessor. And, setting income at nought, it surely behoves a man of property to pay some attention to the character of his estates. For what can well add more to the permanent respectability of a family of rank or fortune than having its estates occupied by a wealthy and respectable tenantry?

4307. *In a state of civilised society and property, one of the great arts of life is to teach character and interest to go hand in hand,* and on ordinary occasions to endeavor to turn every incident, as it fortuitously occurs, to their mutual advantage. If a tenant of capital and an improving spirit be found upon an estate, give him due encouragement, for the purposes already explained. On the contrary, if another is found to possess refractory habits, to swerve from his engagements, or to injure the lands in his occupation, it is but common prudence to take the first legal and fair opportunity of dismissing him, and supplying his place with another who is better qualified to fill it; not more with a view of rescuing his particular farm from further injury, and of making an example of him, in terror to others of similar habits, than to preserve and heighten the character of the estate.

4308. *These remarks may be considered as applicable chiefly to small tenants,* or such as from ignorance and want of leases may be considered as in a state of bondage. It ought never to be in the power of a landlord to make "an example of a tenant in terror to others;" it is enough if this power be left to the laws. A tenant who rents a farm on certain conditions, and fulfils them, is, in point of obligation, on an equality with his landlord; neither is obliged to the other: and while the one does not require those acts of kindness and liberality which Marshal inculcates, the other is not entitled to that submission and slavish deference so common among tenants at will, and indeed most others in England. It is justly observed by Brown (*Treat. on Rur. Aff.*), that the moral excitement, or degree of encouragement given to the tenant for improving the ground put under his occupation, is regulated entirely by the terms or conditions of the lease under which he holds possession. If the conditions be liberal and judicious, and accommodated to the soil and situation of the land thereby demised to the tenant, all that is obligatory upon the proprietor is faithfully discharged. But when matters are otherwise, when the tenant possesses under a short lease, when the covenants or obligations are severe in the first instance, and ultimately of little avail towards forwarding improvement; it may reasonably be inferred that the connection is improperly constituted, and that little benefit will thence follow either to the public or to the parties concerned.

#### SUBJECT. 2. *On the Business of letting Farms.*

4309. There are *three methods of letting a farm*: putting it up to public auction, and taking the highest bidder for a tenant: receiving written proposals, and accepting the highest offer, and asking more rent for it than it is worth: haggling with different chapmen, and closing with him who promises to give the most money, without regard to his eligibility as a tenant. After a variety of obvious remarks, Marshal concludes, that "seeing in every situation, there is at all times a fair rental value, or market price of lands; as of their products, there appears to be only one rational, and eventually profitable method of letting a farm; and this is to fix the rent, and choose the tenant. In the choice of a tenant every body knows the requisite qualifications to be, capital, skill, industry, and character. The respective advantages of these qualities are amply developed in *The Treatise on Landed Property.*"

#### SUBJECT. 3. *Of the different Species of Tenancy.*

4310. *The different holdings in use in Britain,* are at will, from year to year, for a term of years, or for a life or lives.

4311. *The tenant holding at will,* or until the customary notice be given by either party to the other, is without any legal contract, or written agreement; the only tie between the owner and the occupier being the custom of the estate, or of the country in which it lies, and the common law of the land. This may be considered as the simple holding which succeeded the feudal or copyhold tenure; but which is now fast going into disuse.

4312. *Holding from year to year,* under a written agreement, with specified covenants, is a more modern usage, and becoming more and more prevalent in some parts of England, and among small tenants, even where leases for a term of years were formerly granted.

4313. *Leases for a term of years*, as seven, fourteen, twenty-one, or a greater number of years, certain; but without the power of assignment, unless with the consent of the lessor.

4314. *Leases for lives*; as one, two, three, or more, without the power of assignment. In Britain, life leases of this description are now rarely granted. In Wales and Ireland they are still prevalent; the rent being there settled according to the value of the land at the time of letting; as on granting a lease for a term. And in the western extreme of England, what are termed life-leases are still common. But they are rather pledges for money taken up, or deeds of sale for lives, than leases. For nearly the whole of the estimated sale value of the land, during the life term, is paid down at the time of purchase; the seller reserving only a quit rent, or annual acknowledgement.

4315. *A lease for a term of years*, or for two or more lives, can alone be favorable for the progress of agriculture. A farmer holding at will, or from year to year, may plough, sow, and reap; but he will, if a prudent man, be very careful not to make improvements, well knowing that the first effect would be, a rise of rent or a notice to quit. Leases for a single life have the great disadvantage of uncertainty as to duration, both as landlord and tenant; and though the latter may insure a certain sum on his life for the benefit of his family, yet it were better that he should lay out that money in improving the farm. Leases on lives, renewable, are for all purposes of culture as good as freehold; but they have this disadvantage to a tenant, that they require a considerable part of his capital paid down, and a further draught on his capital on the falling in of any of the lives. Even the first of these payments would embarrass the great majority of professional farmers, and disable them from bestowing proper cultivation on the soil; but to a farmer with a surplus capital no description of lease can be better, as he lays out his surplus capital at the market rate of interest, and is, as it were, his own annuitant. To the landlord such leases cannot be advantageous, because, there being fewer who can compete for them, lands let on these conditions, do not fetch their full price.

4316. *The fundamental principle* from which both the duration and conditions of leases are established is evidently this: A. agrees to lend to B. a certain article for his use for an equivalent in money; but such is the nature of this article, that in order to use it with advantage, B. must possess it during a considerable time; he, therefore, requires a security from A. to that effect; and A. on his part requires a security from B. that he will return the article at least in as good condition as when it was lent to him. The term of years for which the article is to be lent, and the precautions taken to ensure its return without deterioration, are founded on experience, and vary according to the peculiar circumstances of lender and borrower. In general, however, this is obvious; that where the period of lending is not sufficient for profitable use; or the conditions required for ensuring the lender an undeteriorated return of the article unreasonable, the value of the loan or rent will be proportionably diminished. (*Sup. Enc. Brit. art. Agr.*)

4317. *In recurring to what actually exists in the best cultivated districts*, we shall quote the excellent observations of an experienced farmer and approved public writer. "The general principle which should regulate the connection between landlord and tenant seems to be, that while the farm ought to be restored to the owner at the expiration of the tenant's interest, at least without deterioration, the tenant should be encouraged to render it as productive as possible during his possession. In both of these views, a lease for a term of years is scarcely less necessary for the landlord than for the tenant; and so much is the public interested in this measure, that it has been proposed by intelligent men, to impose a penal tax on the rent of lands held by tenants at will.

4318. *That the value of the property is enhanced by the security which such a lease confers on the tenant*, will be put beyond all doubt, if the rents of two estates for half a century back are compared; the one occupied by tenants at will, and the other by tenants on leases for a moderate term, and where the soil and situation are nearly alike in every respect. If the comparison be made between two tracts, originally very different in point of value, the advantages of leases will be still more striking; while that which is held by tenants at will remains nearly stationary, the other is gradually, yet effectually, improved, under the security of leases, by the tenants' capital; and, in no long period, the latter takes the lead of the former, both in the amount of the revenue which it yields to the proprietor, and in the quantity of produce which it furnishes for the general consumption. The higher rents and greater produce of some parts of Scotland than of many of the English counties, where the soil, climate, and markets are much more favorable, must be ascribed to the almost universal practice of holding on leases in the former country, in a much greater degree than to any of the causes which have been frequently assigned. Less than a century ago, what are now the best cultivated districts of Scotland were very far behind the greater part of England; and, indeed, had made very little progress from the time of the feudal system. It is not fifty years since the farmers of Scotland were in the practice of going to learn of their southern neighbors an art, which was then very imperfectly known in their own country. But in several parts of England there has been

little or no improvement since, while the southern counties of Scotland have uniformly advanced; and at present exhibit very generally, a happy contrast to their condition in the middle of the last century.

4319. *In respect to farmers themselves*, it cannot be necessary to point out the advantages of leases. It may be true, that, under the security of the honor of an English landlord, tenants at will have been continued in possession from generation to generation, and acquired wealth which he has never, like the landholders of some other countries, attempted to wrest from them. But there are few individuals in any rank of life, who continue for a length of time to sacrifice their just claims on the altar of pure generosity. Something is almost always expected in return. A portion of revenue in this case is exchanged for power, and that power is displayed not only in the habitual degradation of the tenantry, but in the control over them, which the landlord never fails to exert at the election of members of parliament, and on all other political emergencies. No prudent man will ever invest his fortune in the improvement of another person's property, unless, from the length of his lease, he has a reasonable prospect of being reimbursed with profit; and the servility which holding at will necessarily exacts, is altogether incompatible with that spirit of enterprise which belongs to an enlightened and independent mind.

4320. *Every measure which has a tendency to fetter the productive powers of the soil*, must deeply affect the public at large, as well as depress one of the largest and most valuable classes. It is clearly their interest, that corn and other provisions should be supplied in abundance, and the people of England may justly complain of the want of leases, as one of the principal causes which checks the improvement of their own territory.

4321. *What ought to be the term of a lease*, can only be determined by a reference to the circumstances of each particular case. Lands naturally rich, or such as have already been brought to a high degree of fertility, requiring no great investment of capital, and returning all or nearly all the necessary outlay within the year, may be advantageously held upon short leases, such as perhaps give time for two, or at most three, of the rotations or courses of crops to which the quality of the soil is best adapted. The practice of England in this respect is extremely various, almost every term, from twenty years downwards, being found in different parts of it. In Scotland, by far the most common period is nineteen years, to which it was formerly the practice, in some places, to add the life of the tenant. In that country, even when it is thought expedient to agree for a much longer term, this is still expressed in periods of nineteen years, a sort of mysterious cycle, which seems to be no less a favorite with the courts of law, than with landholders and farmers. Yet this term is somewhat inconvenient, as it can never correspond with any number of the recognised rotations of arable land.

4322. *A lease for twenty years*, it has been maintained by several writers, is not sufficient to reimburse a tenant for any considerable improvements, and landholders have often been urged to agree to a much longer term, which, it is alleged, would be not less for their own interest than for that of the tenant. This is a question which our limits do not permit us to discuss, but, after viewing it in different lights, assisted by the experience of long leases in different parts of Scotland, we cannot help expressing some doubts of their utility, even in so far only as regards the parties themselves; and we are decidedly of opinion, that a greater produce will be brought to market, from any given extent of land held on successive leases of twenty years, for half a century, than if held on one lease of that duration, whether the term be specified or indefinite, as is the case of a lease for life. As a general mode of tenure, leases for lives seem to us particularly objectionable.

4323. *The great advantages of a lease* are so well known in Scotland, that one of her best agricultural writers, himself a landed proprietor, has suggested a method of conferring on it the character of perpetuity, to such an extent as, he thinks, would give ample security to the tenant for every profitable improvement, without preventing the landlord from resuming possession upon equitable terms, at the expiration of every specified period. But the author of this plan (Lord Kaim), in his ardent wishes for the advancement of agriculture, at that time in a very backward state in his native country, seems to have overlooked the difficulties that stood in the way of its adoption; and the great advance in the price of produce, and consequently in the rate of rents, since his lordship wrote, have long since put an end to the discussion which his proposal excited. For a form of a lease on his plan, the reader may consult Bell's *Treatise on Leases*; and the objections to the plan itself are shortly stated in the supplement to the sixth edition of *The Gentleman Farmer*, recently published.

4324. *Long leases granted upon condition of receiving an advance of rent at the end of a certain number of years* have been granted; but covenants of this kind, meant to apply to the circumstances of a distant period, cannot possibly be framed in such a manner as to do equal justice to both parties; and it ought not to be concealed, that, in every case of a very long lease, the chances are rather more unfavorable to the landholder than to the

farmer. If the price of produce shall continue to rise as it has done, till very lately, for the last forty years, no improvements which a tenant can be expected to execute will compensate the landlord's loss; and if, on the other hand, prices shall decline, the capital of most tenants must be exhausted in a few years, and the lands will necessarily revert to the proprietor, as has been the case of late in many instances. Hence a landholder, in agreeing to a long lease, can hardly ever assure himself, that the obligations on the part of the tenant will be fully discharged throughout its whole term, while the obligations he incurs himself may always be easily enforced. He runs the risk of great loss from a depreciation of money, but can look forward to very little benefit from a depreciation of produce, except for a few years at most. Of this advantage a generous man would seldom avail himself; and, indeed, in most instances, the advantage must be only imaginary, for it would be overbalanced by the deterioration of his property." (*Sup. Encyc. Brit. art. Agr.*)

4325. There are various objections made to leases of nineteen or twenty-one years. Some of these are of a feudal and aristocratical nature; such as the independence it gives the tenants who may become purse-proud and saucy under the nose of their landlord, &c. A greater objection has arisen from the depreciation of British currency during the last ten years of the eighteenth, and first ten of the nineteenth centuries. Various schemes have been suggested to counteract this evil; but the whole of them are liable to objections, and it may be safely stated, that it admits of no remedy, but the generous interference of the landlord.

#### SUBJECT. 4. *Of the Rent and Covenants of a Lease.*

4326. To avert the evils of fixed money rents, and long leases, both to landlords and tenants, the best mode known at present is the old plan of corn rents. This plan was first revived in 1811, by a pamphlet published in Cupar, which attracted considerable attention, and has led to the adoption in various parts of Scotland, of a mixed mode of paying rents, partly in corn or the price of corn, and partly in money. In hilly districts, instead of corn, wool, or the price of wool for an average of years, is sometimes fixed on. We shall quote from the same intelligent writer, on the duration of leases, his sentiments on corn rents, and subjoin his observations on covenants.

4327. Though the most equitable mode of determining the rent of lands on lease, would be to make it rise and fall with the price of corn; yet, "a rent paid in corn is liable to serious objections, and can seldom be advisable in a commercial country. It necessarily bears hardest on a tenant when he is least able to discharge it. In very bad seasons, his crop may be so scanty, as scarcely to return seed and the expenses of cultivation, and the share which he ought to receive himself, as the profits of his capital, as well as the quantity allotted to the landlord, may not exist at all. Though, in this case, if he pays a money rent, his loss may be considerable, it may be twice or three times greater if the rent is to be paid in corn, or according to the high price of such seasons. In less favorable years, which often occur in the variable climate of Britain, a corn rent would, in numerous instances, absorb nearly the whole free or disposable produce, as it is by no means uncommon to find the gross produce of even good land reduced from twenty to fifty per cent. below an average, in particular seasons. And it ought to be considered, in regard to the landlord himself, that his income would thus be doubled or trebled, at a time when all other classes were suffering from scarcity and consequent dearth; while, in times of plenty and cheapness, he might find it difficult to make his expenses correspond with the great diminution of his receipts. It is of much importance to both parties, that the amount of the rent should vary as little as possible from any unforeseen causes, though tenants in general would be perhaps the most injured by such fluctuations.

4328. To obviate these and other objections to a corn rent, and to do equal justice at all times to both landlord and tenant, a plan has been lately suggested for converting the corn into money, adopting for its price, not the price of the year for which the rent is payable, but the average price of a certain number of years. The rent, according to this plan, may be calculated every year, by omitting the first year of the series, and adding a new one; or, it may continue the same for a certain number of years, and then be fixed according to a new average. Let us suppose the lease to be for twenty-one years, the average agreed on being seven years, and the first year's rent, that is, the price of so many quarters of corn, will be calculated from the average price of the crop of that year, and of the six years preceding. If it be meant to take a new average for the second and every succeeding year's rent, all that is necessary is, to strike off the first of these seven years, adding the year for which the rent is payable, and so on during all the years of the lease. But this labor, slight as it is, may be dispensed with, by continuing the rent without variation for the first seven years of the lease according to the average price of the seven years immediately preceding its commencement, and, at the end of this period, fixing a new rent, according to the average price of the seven years just expired, to continue for the next seven years. Thus, in the course of twenty-one years, the rent would be calculated only



three times; and for whatever quantity of corn the parties had agreed, the money payments would be equal to the average price of fourteen years of the lease itself, and of the seven years preceding it; and the price of the last seven years of the old lease, would determine the rent during the first seven years of the new one.

4329. *The landlord and tenant could not suffer*, it has been thought, either from bad seasons or any change in the value of the currency, should such a lease as this be extended to several periods of twenty-one years. The quantity of corn to be taken as rent, is the only point that would require to be settled at the commencement of each of those periods; and though this would no doubt be greater or less, according to the state of the lands at the time, yet it may be expected, that in the twenty-one years preceding, all the tenant's judicious expenditure had been fully replaced. Instead of the twofold difficulty in fixing a rent for a long lease, arising from uncertainty as to the quantity of produce, which must depend on the state of improvement, and still more perhaps from the variations in the price of that produce, the latter objection is entirely removed by this plan; and in all cases where land is already brought to a high degree of fertility, the question about the quantity of produce may likewise be dispensed with.

4330. *If the corn rent plan be applied to leases of nineteen or twenty-one years*, the inconvenience resulting from uncertainty as to the amount of rent, as well as other difficulties which must necessarily attend it, would be as great perhaps as any advantages which it holds out to either of the parties. If it be said that a rent, determined by a seven year's average, could not suddenly nor materially alter, this is at once to admit the inutility of the contrivance. The first thing which must strike every practical man is, that corn is not the only produce of a farm, and in most parts of Britain, perhaps not the principal source from which rent is paid; and there is no authentic record of the prices of butcher meat, wool, cheese, butter, and other articles in every county to refer to, as there is of corn. This is not the place to inquire whether the price of corn regulates the price of all the other products of land, in a country whose statute books are full of duties, bounties, drawbacks, &c. to say nothing of its internal regulations; but it is sufficiently evident, that if corn does possess this power, its price operates too slowly on that of other products to serve as a just criterion for determining rent on a lease of this duration. Besides, in the progress of agriculture, new species or varieties of the *cerealia* themselves are established even in so short a period as twenty-one years, the prices of which may be very different from that of the corn specified in the lease. What security for a full rent, for instance, would it give to a landlord, to make the rent payable according to the price of barley, when the tenant might find it more for his interest to cultivate some of the varieties of summer wheat, lately brought from the continent? or, according to the price of a particular variety of oats, when, within a few years, we have seen all the old varieties superseded throughout extensive districts, by the introduction of a new one, the potatoe-oat, which may not be more permanent than those that preceded it? There can be no impropriety, indeed, in adopting this plan, for ascertaining the rent of land kept always in tillage; but it would be idle to expect any important benefits from it, during such a lease as we have mentioned.

4331. *The corn rent plan, in the case of much longer leases*, will no doubt diminish the evils which we think are inseparable from them, but it cannot possibly reach some of the most considerable. Its utmost effect is to secure to the landholder a rent which shall in all time to come be an adequate rent, according to the state of the lands and the mode of cultivation known at the date of the lease. But it can make no provision that will apply to the enlargement of the gross produce from the future improvement of the lands themselves, or of the disposable produce from the invention of machinery and other plans for encouraging labor. And the objections just stated, in reference to a lease of twenty-one years, evidently apply much more forcibly to one of two or three times that length. Old corn-rents, though much higher at present than old money-rents, are seldom or never so high as the rents could now be paid on a lease of twenty-one years. But, independent of these considerations, which more immediately bear upon the interests of the parties themselves, one insuperable objection to all such leases is, that they partake too much of the nature of entails, and depart too far from that commercial character which is most favorable to the investment of capital, and consequently to the greatest increase of land produce.

4332. *A lease for a term of years is not, in all cases, a sufficient encouragement to spirited cultivation*; its covenants in respect to the management of the lands may be injudicious; the tenant may be so strictly confined to a particular mode of culture, or a particular course of crops, as not to be able to avail himself of the beneficial discoveries which a progressive state of agriculture never fails to introduce. Or, on the other hand, though this is much more rare, the tenant may be left so entirely at liberty, that either the necessity of his circumstances, during the currency of the lease, or his interest towards its expiration, may lead him to exhaust the soil, instead of rendering it more productive. When a lease therefore is either redundant or deficient in this respect; where it either permits the lands to

be deteriorated or prevents their improvement; the connection between landlord and tenant is formed upon other views, and regulated by some other principle, than the general one on which we think it should be founded.

4333. *Restrictive covenants are always necessary to the security of the landlord*, notwithstanding the high authority of Dr. Smith to the contrary, and in some cases beneficial to the tenant. Their expediency cannot well be questioned in those parts of the country where an improved system of agriculture has made little progress. A landholder, assisted by the advice of experienced men in framing these covenants, cannot adopt any easy or less offensive plan for the improvement of his property, and the ultimate advantages of his tenantry. Even in the best cultivated districts, while farms continue to be let to the highest responsible offerers, a few restrictive covenants cannot be dispensed with. The supposed interest of the tenant is too feeble a security for correct management, even during the earlier part of a lease, and in the latter part of it, it is thought to be his interest, in most cases, to exhaust the soil as much as possible, not only for the sake of immediate profit, but frequently in order to deter competitors, and thus to obtain a renewal of his lease at a rent somewhat less than the lands would otherwise bring.

4334. *With tenants at will*, and such as hold on short leases, restrictive covenants are more necessary than with tenants on leases of nineteen or twenty years; but in many instances, they are too numerous and complicated, and sometimes even inconsistent with the best courses of modern husbandry. The great error lies, in prescribing rules by which a tenant is positively required to act, not in prohibiting such practices and such crops as experience has not sanctioned. The improved knowledge, and the liberality of the age, have now expunged the most objectionable of these covenants; and throughout whole counties, almost the only restriction in reference to the course of crops is, that the tenant shall not take two culmiferous crops, ripening their seeds in close succession. This single stipulation, combined with the obligation to consume the straw upon the farm, and to apply to it all the manure made from its produce, is sufficient not only to protect the land from exhaustion, but to ensure in a great measure its regular cultivation; for half the farm at least must, in this case, be always under either fallow or green crops. The only other necessary covenant, when the soil is naturally too weak for carrying annual crops without intermission, is, that a certain portion of the land shall be always in grass, not to be cut for hay but depastured. According to the extent of this will be the interval between the succession of corn crops on the same fields; if it is agreed that half the farm, for instance, shall always be under grass, there can be only two crops of corn from the same field in six years. In this case not more than two-sixths being in corn, one-sixth in green crops or fallow, and three-sixths in clover or grasses, it becomes almost impossible to exhaust any soil at all fitted for tillage. There are few indeed that do not gradually become more fertile under this course of cropping. It is sufficiently evident, that other covenants are necessary in particular circumstances; such as permission to dispose of straw, hay, and other crops from which manure is made, when a quantity of manure equal to what they would have furnished is got from other places; and a prohibition against converting rich old grazing lands or meadows into corn lands. In this place we speak only of general rules, such as are applicable to perhaps nine-tenths of all the arable land of Britain, and such as are actually observed in our best cultivated counties.

4335. *For the last four years of a lease*, the same covenants are generally sufficient, only they require to be applied with more precision. Instead of taking for granted, that the proportion of the farm that cannot be under corn will be properly cultivated, from the tenant's regard to his own interest, it becomes necessary to make him bound to this effect in express terms; the object generally being to enable the tenant, upon a new lease, to carry on the cultivation of the lands, as if the former lease had not terminated. What these additional stipulations should be, must depend in part on the season of the year at which the new lease commences, and in part on the course of crops best adapted to the soil, and the particular circumstances of every farm.

4336. With respect to the *form of a lease*, as no one form would suit every district, nothing specific can be laid down with advantage. The lawyers of every estate have particular forms, and it is easy for them, in concert with the proprietor or manager, to obliterate useless or injurious restrictions, and substitute such as may be deemed best for the estate, or in harmony with the progress of the age." (*Sup. Encyc. Brit. art. Agr.*)

#### SUBJECT. 5. *Of receiving Rents.*

4337. *The business of receiving the rents and profits of a landed estate*, simple as it may seem, is subject to analysis, and entitled to consideration. Indeed, on large properties, on which not farm rents only, but various other profits are to be received; as cottage rents, tith compositions, chief rents, and perhaps, quit rents of copyhold lands; the business becomes so complex as to require to be methodised and simplified, in order to obtain the requisite facility and dispatch. This is generally best effected by appointing distinct days, or distinct parts of the day, for each receipt, so that the different tenants and suitors may know their hours of attendance.

4338. *The business of holding manor courts* depends on whether they are held of right, or merely by custom. If the copyhold tenure is so far worn out in any manor, that there are not two ancient or feudal tenants remaining within it, the court has lost its legal power; it cannot by right, take cognizance of crimes, nor enforce americiaments. Nevertheless, manorial courts have their uses, in regulating farm roads, driftways, and watercourses, and in preventing nuisances of different kinds within a manor; and it is generally right to preserve the custom of holding them for these purposes.

4339. *Where copyhold courts remain in force*, and where legal forms are to be observed, a law "steward of the manor" is proper to hold them. It is not necessary, however,

that courts of this kind should interfere with the receipt of farm rents ; or that a business of this nature should in any way clash with the general receivership of the estate. Employ an attorney to hold courts, as a surveyor to arbitrate disputes, or an engineer to plan works of improvement.

4340. *The propriety of having fixed days for receiving the rents of farms* is evident, and some consideration is required to determine on the season of the year for holding them, so as not to oblige the farmer to forced sales of his produce. In England and Ireland, farm rents are generally due at Ladyday and Michaelmas, and in Scotland at Candlemas and Lammas. But the proper times of paying them depend on the marketable produce of an estate, and on the season of the year at which it goes in common course, and with the best advantage to market. A tenant should never be forced to sell his produce with disadvantage ; nor when he has received his money for it, ought he to be at a loss for an opportunity of discharging his debt to his landlord. On corn-farm estates, or those whose lands are kept in a state of mixed cultivation, which comprise the great mass of farm lands in this kingdom, Michaelmas may be considered as one of the worst times of the year, at which to call upon tenants for their rents. It is at the close (or, in the northern provinces, perhaps at the height) of harvest, when the farmers' pockets are drained by extra labor, and when they have not yet had time to thresh out their crops to replenish them ; nor is the summer's grass at that season yet consumed, nor off-going stock, perhaps, yet ready for market. In Norfolk, Marshal found the end of February or beginning of March, a very fit time to pay the half year's rent due at Michaelmas ; and June for paying those due at Ladyday. In some districts of the north it used to be the custom not to demand the first half year's rent, till the tenant was a year in his farm, by which means he had the use during his lease of nearly a year's rent in addition to his actual capital. But farmers there, being now considered as possessed of more wealth than formerly, the first half year's rent of the lease is paid nine months after possession, and the last half year's rent of the term on or immediately before its expiry.

4341. *The proper days for receiving rents* are to be sought for in the local circumstances of an estate, and the district in which it lies : most especially in the fairs of the neighborhood at that season ; and in other stated times, at which the tenants are accustomed, in conformity with the practice of the country, to receive for their dairy produce, or other articles, delivered in to dealers ; fixing the rent days, immediately after these days of imbursement.

4342. *On the subject of arrears*, a good deal has been said by Marshal ; but it is one of those which may very safely be left to the good sense and discretion of the proprietor or his manager.

### SECT. III. *Of Keeping and Auditing Accounts.*

4343. *Clearness and brevity* constitute the excellence of accounts, and these excellencies are only to be obtained by simplicity of method. Where lands lie in detached estates so as to require different receivers, a separate account is necessarily required for each receivership ; but to preserve this simplicity and clearness, it is necessary that the several sets should be precisely in the same form.

4344. *The ground-work of the accounts peculiar to a landed estate*, is the rent-roll : from this receiving rentals are to be taken, and with these and the miscellaneous receipts and disbursements incident to the estate, an account current is to be annually made out.

4345. *The receiving rental*, or particulars which a receiver wants to see, at one view, when receiving the rents of an estate under judicious management, — where rents are regularly received, — and where occupiers pay taxes and do ordinary repairs, — are few : the name of the farm, the name of the tenant, and the amount of his half year's rent, only are required. But upon an estate, on which arrears are suffered to remain, and on which matters of account are liable to take place, a greater number of particulars are necessary ; as the name of the farm, of the tenant, his arrears, his half year's rent, any other charge against him, any allowance to be made him, and the neat sum receivable, leaving a blank for the sum received and another for the arrear left.

4346. *Accounts current* are required to be delivered in annually by the acting manager, who ought generally to be the receiver. If the current receipts and disbursements are numerous, as where extensive improvements are going on, and woods, mines, quarries, &c. in hand, such accounts may be given in monthly which will show the progress of the several concerns, and simplify the business at the end of the year.

4347. *On the best managed estates* it is usual, besides the books which have been mentioned, to keep a ledger ; opening separate accounts for farm lands, woods, mines, quarries, waters, houses and their appurtenances, public works, &c. : and where a proprietor has several detached estates, besides such accounts being kept on each, one master ledger contains accounts for each property. This, indeed, is nothing but an obvious

application of mercantile book-keeping to territorial property, the advantages of which cannot but be as great in the one case as in the other.

4348. *In auditing estate accounts*, the rent accounts are to be checked with the arrears of the preceding year; the column of rents with the rent-roll, corrected up to the last term of entry in order to comprise the fresh lettings, and the columns of account with the particulars; those of allowances being signed by the respective tenants.

4349. *The monthly accounts of receipts and disbursements*, as well as the annual payments, are to be compared with vouchers. The receipts are checked by deeds of sale, contracts, and other written agreements, the awards of referees, or the estimates of surveyors, the market prices of produce, &c. &c.; the receiver, in every case, identifying the person, from whom each sum was received. Each disbursement requires a direct and sufficient voucher, endorsed and numbered; with a corresponding number affixed to the charge in the account; so that they may be readily compared.

4350. *The most essential part of the office of an auditor* is that of entering into the merits of each receipt and payment; and considering whether the charges correspond with the purposes for which they are made; and whether the several sums received are adequate to the respective matters disposed of; by these means detecting, and thenceforward preventing, imposition and connivance. This, however, is an office which no one but a proprietor, or other person who has been conversant with the transactions that have taken place upon the estate, and who has a competent knowledge of rural concerns, can properly perform. It may therefore be right to repeat, that if a proprietor has not yet acquired a competent knowledge of his own territorial concerns, to form an adequate judgment of the different entries in his manager's account, let him call in the assistance of those who are conversant in rural affairs, to enable him to judge of any particular parts that may seem to require it; and not set his hand to an account which he does not clearly understand; nor authorize another to sign it, who may have less knowledge than he has of its merits.

---

## BOOK V.

### OF THE SELECTION, HIRING, AND STOCKING OF FARMS.

4351. *Farms or lands let out to men who cultivate it as a business or profession*, exist in all highly civilised countries. Sometimes the farmer or tenant pays to the proprietor or landlord a proportion of the produce, determined yearly, or as the crops ripen; and sometimes he pays a fixed quantity of produce, or labor, or money, or part of each of these. In Britain, where farming, as a profession, is carried to a higher degree of perfection than in any other country, the connection between landlord and tenant is regularly defined by particular agreements and general laws; and the latter, on entering on a farm, engages to pay a fixed sum for its use for a certain number of years. This sum is fixed according to the estimated value of the land; but being fixed, and for a certain time, it admits of no abatement in proportion to the quantity or value of the produce, as in the proportional or metayer system, general in most countries (265. and 585.); and hence the necessity of a farmer maturely considering every circumstance connected with a farm before he becomes its tenant. The subjects of consideration form the business of this Book, and naturally divide themselves into such as relate to the farm; to the farmer; and to the landlord.

---

## CHAP. I.

### *Of the Circumstances of a Farm necessary to be considered by a proposed Tenant.*

4352. *Whoever intends to become a professional, or rent-paying farmer*, will, in searching for a farm, find it necessary to attend to a great variety of considerations. Those of the greatest importance may be included under climate, soil and subsoil, character of surface, topographical position, extent, buildings, roads, fields, tenure, rent, and outgoings. In *The Code of Agriculture*, a more valuable collection of facts as to these points is brought together than in any other work, and from it, therefore, we shall select the greater part of the following sections.

SECT. I. *Of Climate in respect to farming Lands.*

4353. *The climate of a farm* is one of the circumstances over which human art has less control than any other; and a farmer who has but a temporary interest in his possession may be considered as incapable of exercising any influence over it. He may improve the soil and subsoil by draining and culture; and the buildings, roads, and fences by additions and alterations; but it is for the landlord to attempt improving the climate by planting, and for a future generation to enjoy the effects.

4354. *Sufficient attention*, it is said in *The Code of Agriculture*, "is rarely paid by the farmer to the nature of the climate in which his operations are carried on. Unless the system he adopts be calculated for the weather his crops are likely to experience, every exertion will often terminate in disappointment. The system that is proper for warm and dry situations, is not suitable for cold and wet ones; and in a bleak and backward climate, the nature of the soil ought not only to be attended to, but the utmost care ought to be paid to the early sowing of the earliest varieties of seed. Even the species of stock to be bred, or kept on a farm, should in a great measure be regulated by the climate. Hence, this is a subject which the diligent farmer will invariably study with the greatest solicitude. Climate and soil, Curwen justly remarks, are, above all other considerations, those which the farmer ought constantly to keep in view." (*Report to the Workington Society.*)

4355. *In considering the climate of a country*, the following points are of peculiar importance: its general character, and the means of its improvement; its local heat; the light it furnishes; the quantity of its moisture; the prevailing winds; its position, whether maritime or inland; the regularity of the seasons; the phenomena to which it is liable; and the productions best suited to it; the expenses it may occasion in cultivation; and its suitableness for the introduction of exotic plants, and animals from other climates.

4356. *The general character of a climate* not only depends on position or latitude, but likewise on the elevation of a country above the level of the sea; its general aspect; the vicinity to mountains, forests, bogs, marshes, lakes, and seas; the nature of the soil and subsoil, and the power which the former possesses of retaining heat and moisture; the direction of the winds; the length of time the sun continues above the horizon; the difference of temperature between the day and the night; and the extent of dry surface in the neighborhood. The result of these particulars combined, form, what may be called, the general character of climate. Some of the causes of an unfavorable climate cannot be remedied by any human effort; in other cases art may effect much; but that art is generally such as the farmer can seldom undertake unless with a very long lease. Ameliorations of this sort, therefore, belong to the landlord.

4357. *The importance of heat*, as a stimulus to vegetation, cannot be doubted. It is at a certain degree of heat that vegetation commences, and it becomes nearly stationary when the temperature falls below it. There are, comparatively speaking, but few plants calculated for very cold countries, and these are seldom valuable; whereas in warm and temperate regions, the variety is great, and their value unquestionable. Indeed, such is the effect of cold, that while the thermometer is below 40° of heat, the strongest plants become torpid, and remain in that state while it continues. Revived by the warmth of spring, and strengthened by the heat of summer, they acquire fresh life and vigor, and are thus better enabled to withstand the rigors of the succeeding winter.

4358. *An increased temperature, when not carried to excess, will augment the quantity of nutritive matter in a plant*, or improve the quality of fruit grown under its influence. Thus English barley, of equal weight, is more valuable than the Scotch, because, from growing in a warmer climate, and enjoying the advantage of a greater quantity of heat and light, it is more fully ripened. It thence acquires more saccharine matter, and produces a greater quantity of spirits, or of malt liquor. It is also proved, by the experiments of Sir Humphry Davy, that wheat ripened in a more regular and warmer climate, contains more of that valuable article called gluten, than the same species of grain when raised in England.

4359. *The average heat of the year* is not, however, of so much importance to the growth of plants, as its duration, and its steadiness at a certain degree, during the season when the grain is ripening. This gives the uniform climates of the continent a great advantage over our variable seasons, in the production of the more delicate sorts of fruit; which, in this island, are often injured by the frosts in spring, and seldom ripen in a northern climate, where the greatest summer heat is both unsteady and of short duration.

4360. *The quantity of solar light* which a climate furnishes, is likewise an important object of inquiry. Light is essential to increase the proportion of starch or farina; to complete the formation of oils in plants; and to give to fruits their proper color and flavor. It has also the effect of augmenting saccharine matter, insomuch that those

sugar-canes which are exposed to the sun, have more of that important ingredient than when they grow under shade. Nor ought the observation to be omitted, that darkness and light have effects directly opposite upon vegetables. Darkness favors the length of the growth, by keeping up the pliancy of their parts; light consolidates them, and stops growth, by favoring maturation. Hence, in the northernmost regions, plants go through all their stages of growth at a time when the sun no longer quits the horizon; and the light, of which they thus experience the unremitting effect, hardens them before they have time to lengthen. Their growth is therefore quick, but of short duration. They are robust, but undersized. (*Mirbel.*) It has been remarked also, that a soil, not retentive, will be more productive in a wet climate than in a dry one. Hence, in the western coasts of England, as in Lancashire, where the quantity of rain that falls annually varies from forty to sixty inches, a siliceous sandy soil is much more productive than the same species of soil in the eastern districts, where seldom more than from twenty-five to thirty-five inches of rain fall in a year. In wet climates also, even wheat and beans will require a less coherent and absorbent soil than in drier situations. At the same time, weather moderately dry, is the most favorable to a great produce of corn; and the blossoms of wheat, in particular, set best if no rain falls in the flowering season.

4361. *The importance of moisture to vegetation* is obvious to every one. Water constitutes a large proportion of every plant, and is the vehicle of the food of plants held in solution. Hence, without so essential an ingredient, they must either become stunted in their growth, or perish. In dry weather, when vegetation seems at a stand, no sooner do showers of rain fall, than a rapid growth, of every kind of herbage, or of corn, immediately succeeds, even on poor dry soils, where otherwise, however well manured, vegetation would make but slow progress.

4362. *The quantity of rain that falls annually in any country*, is a very inferior consideration, when compared with that of the general and equable distribution of that quantity throughout the several days and months of the year. A great quantity, at the same time, is rather hurtful than beneficial; whereas those moderate, but *golden showers*, which regularly fall on a soil calculated to receive them, are real sources of fertility. It is by this that the character of a climate, whether wet or dry, is chiefly determined, and the operations of agriculture are principally influenced.

4363. *The utility of a moist atmosphere, with a view to vegetation*, is, in some respects, peculiarly remarkable. Thus in wet climates, as on the western coasts of England, Scotland, and Ireland, crops of grain and potatoes are found to exhaust the soil less than in dry situations. Oats in particular are impoverishing in a greater degree in dry climates, than in moist ones; and in the former, should be sown much earlier than in the latter.

4364. *The disadvantages of a wet climate to a farmer*, more especially if accompanied with a retentive soil, are very great. It is calculated, that in the richest district in Scotland, the Carse of Gowrie, there are only about twenty weeks in the year fit for ploughing; whereas in several parts of England, they have thirty weeks, and in many cases more, during which this essential operation can be performed. Hence ploughing must be much more expensive in the one case than in the other.

4365. *The season of the year in which rain abounds*, is likewise of much importance. An excess is prejudicial in any season, but is peculiarly so in autumn, when it often lodges the grain by its violence, or, by its long continuance, prevents the corn from being properly harvested. The hopes of the husbandman are thus blasted, and the fruits of his toil and industry are frequently diminished, and sometimes entirely lost.

4366. *Dews have a great effect in furnishing plants with moisture*; and, indeed, without their aid, vegetation, in warm and dry climates, could not go on. Even in temperate regions, dews are beneficial. In Guernsey, on the coast of Normandy, the autumnal dews are singularly heavy, so much so, that in the middle of a hot day, the dew-drops are not quite exhaled from the grass. From this moisture, the after-grass receives great benefit. Dr. Hales estimated the quantity of dew that falls in one year, at three and a half inches: Dalton at nearly five inches. In this matter, however, it is not easy to be correct.

4367. *The prevailing winds* have a great influence on the character of a climate, and a powerful effect on vegetation. When they pass over a large expanse of water, they are usually of a warmer or higher temperature in winter, than those which blow over high lands; more especially if such come from countries covered with snow. Hence the east and north-east winds, which have passed over the coldest regions of Europe, are much colder than the west and south-west winds, which blow over the Atlantic Ocean, and oftener occasions blights. The former are comparatively drier, unless when accompanied by those thick mists, called haars, arising from the copious evaporation of the German Ocean. The latter are loaded with the vapors of the Atlantic, and often, from excess of moisture, are rendered prejudicial. The strength of the prevailing winds, or the

violence with which they act, more especially during harvest, ought likewise to be considered. If they are very violent, they are apt to affect the crops, and of course it becomes an object to suit the produce to them; and to form fences, enclosures, and plantations accordingly.

4368. *A maritime position* occasions a more equal temperature in a climate. Where a great body of land is exposed to the heating rays of the sun, the air becomes much warmer than it would if resting upon a small body of land, contiguous to, or surrounded by the ocean. On the other hand, as the sea always preserves nearly the same temperature, and, except in the most northern regions, is never frozen, it communicates warmth, in the cold seasons of the year, to the air passing over it, which had been cooled in its passage over continents covered with ice and snow. Hence islands are more temperate than continents. It appears indeed, that the thermometer has not so great a range on the sea coast, as in the more inland parts of Great Britain, even at an elevation of 400 feet above the level of the sea. Of the influence of proximity to the sea, many proofs might be brought forward. It is in consequence of this circumstance, that the city of Moscow, which is situated somewhat farther south than Edinburgh, experiences winters much more severe. Another effect of a maritime position is, that strong winds which blow from the sea, are sometimes accompanied by salt spray, or vapor, which is injurious to crops of grain, and the leaves of trees. But when it comes in moderation, those saline particles, with which the westerly winds are loaded, contribute to the verdure of the fields in pasture.

4369. *The nature of the inland position* is also of much importance. The relative position of the neighboring hills, occasioning a material difference of climate, exposing some districts to great severity of weather, and by protecting others from that disadvantage, greatly promoting their fertility.

4370. *In many countries the seasons are regular.* In others, as in Great Britain, they are extremely variable, and often change, in the space of a few hours, from dry to moist, from hot to cold, from clear to cloudy, and from a pleasant serenity to all the violence of a tempest. But such irregularities of climate, however uncomfortable, are often favorable to vegetation, and compensated by the advantages they produce. It is not in countries where the seasons of heat and cold, wind and rain, are periodical, or where the greatest regularity of climate takes place, that mankind are the most healthy or vigorous, or the useful productions of the soil most perfect. Perhaps a sameness of climate, as well as of other things, is prejudicial rather than useful. Where a climate is inconstant, the air is refined and purified by the frequent changes it undergoes; and the disadvantages which originate from that source, are often counteracted, or at least essentially mitigated, by judicious management, and persevering exertions.

4371. *The climate of a country is likewise affected* by atmospherical and natural phenomena; by earthquakes; volcanos; violent thunder storms; lightning; hail storms in summer; early frosts; whirlwinds and hurricanes; water-spouts; and by that atmospherical appearance, known under the name of the *aurora borealis*, so frequently to be seen in northern, and sometimes, even in southern regions; but these phenomena, for the most part only occasional, sometimes prevent greater calamities, and in this country are rarely attended with permanent evils.

4372. *Early frosts* are highly injurious to the blossoms of fruit trees; and autumnal frosts creep along the banks of rivers, destroying the corn in the flowering season, and blasting the stems of potatoes in low situations. Winter frosts are ultimately rather favorable to vegetation; and snow, particularly when it covers the ground for some time, and gradually melts away.

4373. *The size, and, in many cases, the value of the productions of a country, depend upon its climate,* by whose influence their growth may either be advanced or retarded. The same species of tree, which, in a temperate climate, will rise to a great height, and swell to an immense size, in an exposed situation will remain small and stunted. By a favorable climate also, the most barren spots, which in a cold country must remain completely waste, in a warm one may be rendered productive. Thus, where the climate is adapted to the culture of the vine; rocks, which in Great Britain, and in colder countries, would in general be of little or no worth, in the southern provinces of France may yield as much in valuable produce, as the cultivated land in their neighborhood. The real excellence of a climate, however, depends on its yielding, in perfection and abundance, the necessaries of life, or those which constitute the principal articles of food for man, and for the domestic animals kept for his use. In this point of view, a meadow is much more productive, and in some respects more valuable than either a vineyard or a grove of oranges; though the one may be situated in a cold and variable climate, and the other in a country celebrated both for its regularity and warmth of temperature.

4374. *Even the nature of the articles raised,* depends upon the climate. Thus, in many elevated parts, both of England and Scotland, wheat cannot be grown to advantage,

and in some of the high-lying districts of the latter, it has never been attempted. In several of the northern counties, it has been found necessary to sow, instead of the two-rowed barley, the inferior sort called bear, or big; and oats, from the hardy quality of the grain, are found to be a more certain and more profitable species of corn, than any other; while in humid districts, peas or beans cannot be safely cultivated, from the periodical wetness of the autumn. On the whole, without great attention to the nature of the climate, no profitable system can be laid down by any occupier of land.

4375. *An inferior climate greatly augments the expenses of cultivation*, because a number of horses are required for labor, during the short period of the year, when the weather will admit of it, which, at other seasons, are a useless burden upon the farm. When to this are joined an uneven surface, and an inferior quality of soil, arable land is of little value, and yields but a trifling rent.

4376. *Exotic plants or animals* can only be naturalized in climates with success by paying attention to that whence they were brought, and by endeavoring, either to render the one as similar to the other as circumstances will admit of, or to counteract, by judicious management, the deficiencies of the new one.

4377. *In order to ascertain the nature of a climate*, the farmer, in modern times, has many advantages which his predecessors wished for in vain. The progress of science has given rise to many new instruments, which ascertain natural phenomena with a considerable degree of accuracy, instead of conjectures, or systems being founded on loose or general experience. It may still be proper to study the appearance of the heavens, and not to despise old proverbs, which often contain much local truth; but the vane now points out the quarters whence the winds blow, with all their variations; the barometer, often enables us to foretell the state of the weather that may be expected; the thermometer ascertains the degree of heat; the hygrometer, the degree of moisture; and the pluviometer, or rain-gauge, the quantity of rain that has fallen during any given period; and by keeping exact registers of all these particulars, much useful information may be derived. The influence of different degrees of temperature and humidity, occurring at different times, may likewise be observed, by comparing the leafing, flowering, and after-progress of the most common sorts of trees and plants, in different seasons, with the period when the several crops of grain are sown and reaped each year.

#### SECT. II. *Of Soil in respect to farming Lands.*

4378. *The necessity of paying attention to the nature and quality of the soil*, need not be dwelt upon. By ascertaining the qualities it possesses, or by removing its defects, the profits of a farmer may be greatly increased. He must, in general, regulate his measures accordingly, in regard to the rent he is to offer; the capital he is to lay out; the stock he is to keep; the crops he is to raise; and the improvements he is to execute. Indeed, such is the importance of the soil, and the necessity of adapting his system to its peculiar properties, that no general system of cultivation can be laid down, unless all the circumstances regarding the nature and situation of the soil and subsoil be known; and such is the force of habit, that it rarely happens, if a farmer has been long accustomed to one species of soil, he will be equally successful in the management of another. From the attention to the nature of soils, many foolish, fruitless, and expensive attempts have been made to introduce different kinds of plants, not at all suited to them; and manures have often been improperly applied. This ignorance has likewise prevented many from employing the means of improvement, though the expense was trifling, and within their reach. From ignorance also of the means calculated for the proper cultivation of the different soils, many unsuccessful and pernicious practices have been adopted. Soils may be considered under the following general heads: Sandy; gravelly; clayey; stoney; chalky; peaty; alluvial; and loamy, or that species of artificial soil, into which the others are generally brought, by the effects of manure, and of earthy applications, in the course of long cultivation.

4379. *Though sandy soils are not naturally valuable*, yet being easily cultivated, and well calculated for sheep, that most profitable species of stock, they are often farmed with considerable advantage; and when of a good quality, and under a regular course of husbandry, they are invaluable. They are easily worked, and at all seasons; they are cultivated at a moderate expense; are not so liable to injury from the vicissitudes of the weather; and in general they are deep and retentive of moisture, which secures excellent crops even in the driest summers. The crops raised on sandy soils are numerous, such as common turnips, potatoes, carrots, barley, rye, buck-wheat, pease, clover, saintfoin, and other grasses. This species of soil, in general, has not strength enough for the production of Swedish turnips, beans, wheat, oats, flax, or hemp, in any degree of perfection, without much improvement in its texture, the addition of great quantities of enriching manure, and the most skilful management. In Norfolk and Suffolk, it is found that poor sandy soils, unfit for any other purpose, under saintfoin, will produce, after the first year, about two tons per acre, of excellent hay, for several years, with an after-grass,



extremely valuable for weaning and keeping lambs. How much more beneficial, than any crops of grain that such soils usually yield! (*Young's Kalend.* 123.)

4380. *The fertility of sandy soils*, is in proportion to the quantity of rain that falls, combined with the frequency of its recurrence. As a proof of this, in the rainy climate of Turin, the most prolific soil has from seventy-seven to eighty per cent. of siliceous earth, and from nine to fourteen of calcareous; whereas in the neighborhood of Paris, where there is much less rain, the silex is only in the proportion of from twenty-six to fifty per cent. in the most fertile parts.

4381. *Gravelly soils* differ materially from sandy, both in their texture and modes of management. They are frequently composed of small soft stones, sometimes of flinty ones; but they often contain granite, limestone, and other rocky substances, partially, but not very minutely decomposed. Gravel, being more porous than even sand, is generally a poor, and what is called, *a hungry soil*, more especially when the parts of which it consists, are hard in substance, and rounded in form. Gravelly soils are easily exhausted, for the animal and vegetable matters they contain, not being thoroughly incorporated with the earthy constituent parts of the soil, (which are seldom sufficiently abundant for that purpose,) are more liable to be decomposed by the action of the atmosphere, and carried off by water.

4382. *A gravelly soil*, free from stagnant water, gives such an additional warmth to the climate, that vegetation is nearly a fortnight earlier, than where other soils predominate. About Dartford and Blackheath, in Kent, such soils produce early green pease, winter tares, rye, autumnal pease, and occasionally wheat, in great perfection.

4383. *Gravelly soils, in a wet climate*, answer well for potatoes; in Cornwall, in a sheltered situation, with a command of sea-sand, and of sea-weed, they raise two crops of potatoes in the same year.

4384. *Poor gravelly soils, full of springs*, and those sulphureous, are very unfriendly to vegetation; and are better calculated for wood than for arable culture.

4385. *The stoney, shaley, or stone-brash soils* of Gloucestershire, and the midland counties of England, are much mixed with small stones, but have more frequently sand, or clay, or calcareous loam, in their composition, than gravelly soils, and are therefore generally preferable.

4386. *A clayey soil* is often of so adhesive a nature, that it will hold water like a dish. In a dry summer, the plough turns it up in great clods, scarcely to be broken or separated by the heaviest roller. It requires, therefore, much labor to put it in a state fit for producing either corn or grass, and it can only be cultivated, when in a particular state, and in favorable weather. Though it will yield therefore, under a proper system of management, great crops, yet being cultivated at a heavy expense, requiring stronger instruments, and stouter horses, it is seldom that much profit is obtained, unless when occupied by a judicious and attentive farmer. The best management of clay soils, is that of the Lothians. There they are found well calculated for growing crops of beans, wheat, oats, clover, and winter tares; but are not adapted for barley, unless immediately after a fallow; nor for potatoes, unless under very peculiar management. In regard to turnips, they do not usually thrive so well in clays, as in soils which are more free and open. But it is now ascertained, that the Swedish, and above all, the yellow turnip, may be raised in them with advantage; that the quality is superior; that if they are taken up early, the soil is not injured; and that there is no difficulty in preserving them. Clays become good meadow-lands, and answer well for hay, or soiling, when in grass; but from their aptitude to be poached, they are, in general, unfit to be fed by heavy cattle in wet weather. In dry seasons the after-grass may be used to feed neat cattle till October, and sheep till March. A stiff clay, when not cold or wet, with a strong marl under it, is preferred in Cheshire and Derbyshire, for the dairy.

4387. *On reclaimed peat-bogs*, oats, rye, beans, potatoes, turnips, carrots, cole-seed, white and red clover, may be cultivated. Wheat and barley have succeeded on such lands, after they have been supplied with abundance of calcareous earth; and the florin grass (*Agrostis stolonifera*), seems likewise to be well adapted to that description of soil in a warm climate. In Leicestershire, and other counties, they have great tracts of meadow land, which, in many instances, are the sites of lakes filled up, the soil of which is composed of peat and sediment; the former originally formed by aquatic vegetation, and the latter brought down by rains and streams from the upland. This forms a soil admirably calculated for grass.

4388. *The fens* in Cambridgeshire, Lincolnshire, and several other districts in England, consist of peat and sediment.

4389. *Chalky soils* principally consist of calcareous matter, mixed with various other substances, in greater or lesser proportions. Where clayey or earthy substances are to be found in such soils in considerable quantities, the composition is heavy and productive; where sand or gravel abounds, it is light, and rather infertile. The crops chiefly culti-

vated on chalky soils, are pease, turnips, barley, clover, and wheat; and however much the soil is exhausted, it will produce saintfoin.

4390. *Chalky soils are in general fitter for tillage than for grazing*; for without the plough, the peculiar advantages derived from this soil by saintfoin, could not be obtained. The plough, however, ought not to extend to those fine chalky downs, (called ewe leases in Dorsetshire), which, by a very attentive management during a number of years, have been brought to a considerable degree of fertility as grazing land, and which are so useful to sheep in the winter season. A chalky soil that has been in tillage, permits water to pass through it so freely in winter, and is so pervious to the sun's rays in summer, that it is the work of an age to make it a good pasture of *natural grasses*, more especially when the chalk lies near the surface. Hence, in the western counties of England, several thousands of acres of this soil, though not ploughed for thirty years, have scarcely any grass of tolerable quality upon them, and are literally worth nothing. Such soils ought to be laid down with saintfoin.

4391. *Alluvial soils* are of two sorts; one derived from the sediment of fresh, and the other of salt water. Along the sides of rivers, and other considerable streams, water-formed soils are to be met with, consisting of the decomposed matter of decayed vegetables, and the sediment of streams. They are in general deep and fertile, and not apt to be injured by rain, as they usually lie on a bed of open gravel. They are commonly employed as meadows, from the hazard of crops of grain being injured, or carried off by floods, if cultivated.

4392. *Alluvial soils, arising from the operations of salt water*, called *salt marshes* in England, *carses* in Scotland, and *polders* in Holland and Flanders, are composed of the finest parts of natural clay, washed off by running water, and deposited on flat ground, on the shores of estuaries, where they are formed by the reflux of the tide, and enriched with marine productions. They generally have a rich, level surface, and being deep in the staple, they are well adapted for the culture of the most valuable crops. Hence wheat, barley, oats, and clover, are all of them productive on this species of soil; which is likewise peculiarly well calculated for beans, as the tap-root pushes vigorously through it, and finds its nourishment at a great depth. From the great mass of excellent soil, the fertility of these tracts is nearly inexhaustible; but from their low and damp situations, they are not easily managed. Lime, in considerable quantities, is found to answer well upon this species of soil.

4393. *The term loamy soil* is applied to such as are moderately cohesive, less tenacious than clay, and more so than sand. Loams are the most desirable of all soils to occupy. They are friable; can in general be cultivated at almost any season of the year; are ploughed with greater facility, and less strength than clay; bear better the vicissitudes of the seasons; and seldom require any change in the rotation adopted. Above all, they are peculiarly well adapted for the convertible husbandry; for they can be changed, not only without injury, but generally with benefit, from grass to tillage, and from tillage to grass.

4394. *As to the comparative value of soil*, it has been justly remarked, that too much can hardly be paid for a good soil, and that even a low rent will not make a poor one profitable. The labor of cultivating a rich and a poor soil, is nearly the same; while the latter requires more manure, and consequently is more expensive. Poor soils, at the same time, may have such a command of lasting manures, as lime or marl, or even of temporary sorts, like sea-weed, or the refuse of fish, as may render them profitable to cultivate. It is a wise maxim in husbandry, that the soil, like the cattle by whom it is cultivated, should always be kept up in good condition, and never suffered to fall below the work it may be expected to perform.

### SECT. III. *Of Subsoil relatively to the Choice of a Farm.*

4395. *On the nature of the under-stratum* depends much of the value of the surface soil. On various accounts its properties merit particular attention. By examining the subsoil, information may be obtained in regard to the soil itself; for the materials of the latter are often similar to those which enter largely into the composition of the former, though the substances in the soil are necessarily altered, by various mixtures, in the course of cultivation. The subsoil may be of use to the soil, by supplying its deficiencies, and correcting its defects. The hazard and expense of cultivating the surface are often considerably augmented by defects in the under-stratum, but which, in some cases, may be remedied. Disorders in the roots of plants are generally owing to a wet or noxious subsoil. Subsoils are retentive, or porous.

4396. *Retentive subsoils* consist of clay, or marl, or of stone beds of various kinds. A retentive, clayey subsoil is in general found to be highly injurious. The surface soil is soaked with water, is ploughed with difficulty, and is usually in a bad condition for the exertion of its vegetative powers, until the cold sluggish moisture of

the winter be exhaled. By the water being retained in the upper soil, the putrefactive process is interrupted, and manures are restrained from operating, consequently the plants make but little progress. Hence, its grain is of inferior quality, and when in grass, its herbage is coarse.

4397. *A stoney subsoil*, when in a position approaching to the horizontal, is in general prejudicial, and if the surface-soil be thin usually occasions barrenness, unless the rock should be limestone, and then the soil, though thin, can easily be converted into healthy pastures, and, in favorable seasons, will feed a heavy stock. They will also produce good crops of corn, though subject to the wire-worm.

4398. *A porous subsoil* is uniformly attended with this advantage, that by its means all superfluous moisture may be absorbed. Below clay, and all the variety of loams, an open subsoil is particularly desirable. It is favorable to all the operations of husbandry; it tends to correct the imperfections of too great a degree of absorbent power in the soil above; it promotes the beneficial effects of manures; it contributes to the preservation and growth of the seeds; and ensures the future prosperity of the plants. Hence it is, that a thinner soil, with a favorable subsoil, will produce better crops than a more fertile one, incumbent on wet clay, or on cold and non-absorbent rock. Lands whose substratum consists of clean gravel or sand, can bear little sun, owing to their not having the capacity of retaining moisture, and their generally possessing only a shallow surface of vegetable mould. In England this soil was formerly called *rye-land*, being more generally cropped with that species of grain than any other. When such soils are cultivated for barley, they should be early and thick, with seed soaked forty-eight hours in water, or in the exudation from a dung-heap. Thus its simultaneous germination, and ripening at the same time, may be secured.

#### SECT. IV. *Of the Elevation of Lands relatively to Farming.*

4399. *The elevation of lands above the level of the sea* has a material influence on the kind and quality of their produce. Land in the same parallel of latitude, other circumstances being nearly similar, is always more valuable in proportion to the comparative lowness of its situation.

4400. *In the higher districts* the herbage is less succulent and nourishing, and the re-production slower when the land is in grass; while the grain is less plump, runs more to straw, is less perfectly ripened, and the harvest is also later when the produce is corn. It has been calculated that in Great Britain sixty yards of elevation in the land are equal to a degree of latitude; or, in other words, that sixty yards perpendicularly higher, are, in respect of climate, equal to a degree more to the north. In considering the crops to be raised in any particular farm, attention ought therefore to be paid to its height above the level of the sea, as well as to its latitude. In latitude  $54^{\circ}$  and  $55^{\circ}$ , an elevation of 500 feet above that level is the greatest height at which wheat can be cultivated with any probable chance of profit; and even there the grain will prove very light, and will often be a month later in ripening than if sown at the foot of the hills.

4401. *The usual maximum of elevation* may be reckoned between 600 and 800 feet for the more common sorts of grain; and in backward seasons the produce will be of small value, and sometimes will yield nothing but straw. It is proper, at the same time, to remark, that in the second class of mountains in the county of Wicklow, in Ireland, where no other grain is considered to be a safe crop, rye is cultivated with success. Where the soil is calcareous, however, as on the Gloucestershire and Yorkshire wolds, from the superior warmth of that species of soil, compared to cold clays or peat, barley grows in great perfection at an elevation of 800 feet above the level of the sea. Some experiments have been made to raise corn crops, at even a higher elevation, on the celebrated mountain Skiddaw, in Cumberland, but unsuccessfully.

4402. *The greatest height at which corn will grow*, in the more remote parts of Scotland, so as to yield any profit to the husbandman, is stated to be at 500 feet above the level of the sea. At the same time corn has been produced, in other districts of that country, at still higher elevations, in particular at the following places: —

	Feet above the Level of the Sea.		Feet above the Level of the Sea.
Parish of Hume, in Roxburghshire	- 600	Doubruch, in Braemar, Aberdeenshire	129 $\frac{1}{2}$
Upper Ward of Lanarkshire	- 760	Lead-hills, in Lanarkshire	- 1564

4403. *These and other instances* of land being cultivated on high elevations, however, are merely small spots, richly manured, and, after all, producing nothing but crops of inferior barley and oats, and seldom fully ripe or successfully harvested. It is only where the soil is sandy or gravelly, that corn will at all answer in Scotland on such elevated situations; and even then, only when the seasons are propitious, and when there are local advantages, favorable to warmth and shelter, in the situation of the lands.

SECT. V. *Character of Surface in regard to farming Lands.*

4404. *A hilly irregular surface*, whether at a high or low elevation above the sea, is unfavorable to farming. The labor of ploughing, driving home produce, and driving out manure, are greatly increased, while the soil on the summit of steep hills, mounts, or declivities, is unavoidably deteriorated. On the sides of slopes the finer parts of the clay and mould are washed away, while the sand and gravel remain. Hence the soil in such districts often wants a proper degree of tenacity for supporting corn crops. A great part of the manure that is applied in such situations, is likewise soon lost. From various causes also they are colder than the plains.

4405. *Many extensive countries have no perceptible rise.* These have their advantages from uniformity of soil, where it is rich. In other districts, the surface is of a waving description, an inequality which contributes much to the ornament of the country, by the agreeable relief which the eye constantly meets with in the change of objects; while the universal declivity which prevails more or less in every field is favorable to the culture of the land, by allowing a ready descent to any water with which the surface may be encumbered.

SECT. VI. *Of Aspect in respect to farming Lands.*

4406. *Aspect, in hilly or mountainous districts*, is an important subject of attention to the farmer; more especially where the climate is unfavorable. It is proved in a variety of instances, both in the central highlands of Scotland, and in other parts of the kingdom, that where the aspect of a hill is towards the north, the soil is more fertile than when it lies with a southern exposure. This is attributed to the variations from frost to thaw in the spring months, which are greater in a southern than a northern aspect. Hence, while the soil to the north remains locked fast, and secured from waste, the other is loosened by the sun, and carried off by showers falling in the intervals of thaw.

4407. *Soils which face the south* are more liable to have their substance carried away by heavy rains, which are generally impelled from the south and south-west. But though the soil to the north often produces the heaviest crops of grass and hay, yet from possessing a more genial climate, and from the earlier and more powerful action of the sun, both corn and grass are harvested earlier on land which has a southern, than on that which has a northern aspect; and superiority of quality thus compensates for any inferiority in the quantity of the produce.

SECT. VII. *Of the Situation of Farm Lands in regard to Markets.*

4408. *No farming can go on without markets.* The system of farming to be adopted on any particular farm, and the expense attending it, must materially depend on its situation, in regard to markets; to the facility with which its produce can be conveyed, where a contiguous market is wanting; to vicinity to manure, to fuel, and to water.

4409. *The advantages resulting from a vicinity to a market*, or to a large town, by which that is insured, are very great. Some crops, as those of potatoes, turnips, and clover, are frequently sold on the ground, without any further trouble or expense to the farmer; and great quantities of manure may be purchased at a moderate expense. In such situations also there is a ready sale for every article the farm can produce; and the articles sold are not only brought to market at a small expense, but the payment is immediate. For all these reasons, it is contended, and apparently with justice, that the neighborhood of a capital is the most profitable spot to farm in, notwithstanding the high rent of land, and the great expense of labor.

4410. *Where markets are not at hand*, the farmer ought to take into consideration what articles will best suit those at a distance to which his produce must be sent. In such a situation, unless there are facilities for the conveyance of so bulky an article as corn by good roads, or by water-carriage, it is advisable, instead of cultivating grain, to attend either to the dairy husbandry, or to the breeding of stock which can be fattened in other districts where good markets are more numerous. This plan, by which the dairy, the breeding, and the fattening of stock, are made distinct professions, is highly beneficial to the country at large. Stock can be reared cheaper in remote districts than where land is dear and labor high. On the other hand, the purchaser of lean stock avoids the expense and risk of breeding great numbers of animals. His attention is not distracted by a multiplicity of objects; he can alter his system from cattle to sheep, or from sheep to cattle, as is likely to be most profitable; his business is simplified, and the capital he lays out is speedily returned. The division of professions between breeding and feeding (though they may be united in circumstances peculiarly favorable), is on the whole a most important link in the progress of agricultural prosperity.

4411. *In regard to facility of conveyance*, the state of public roads, bridges, iron railways, canals, rivers rendered navigable, and harbors, deserves the consideration of the farmer, and will most materially influence the value of produce.

4412. *The situation of the farm in regard to manures*, for an easy access to lime, chalk, marl, sea-weed, &c. is of essential advantage to cultivation. The price at which these articles can be purchased, their quality, their distance, and expense of conveyance, are likewise of importance. Farms, for example, possessing the advantage of sea-weed contiguous, and in abundance, can pay from fifteen to twenty per cent. more rent per acre than otherwise could be afforded.

4413. *Vicinity to fuel* in the cold and moist regions of Europe, are important considerations to the farmer. In the same county, even in England, the difference of expense is often material. In the Hebrides, from the moistness of the climate, the expense of fuel is reckoned equal to a third part of the rent of the land; and farmers who pay, in some cases, 150*l.* per annum, would give 200*l.* if the landlord would supply them and their servants with fuel.

4414. *Where a farmer is under the necessity of using peat*, from the labor attending the cutting, spreading, drying, and conveying it from a distance, several weeks of his horses and servants are devoted to that sole purpose; and much valuable time is lost, which ought to have been employed in the cultivation of his farm. It has been well remarked, that many farmers, to save five guineas on coal, often expend twenty, in thus misapplying the labor of their horses.

4415. *Where wood is used*, it occupies a great deal of ground, that might often be cultivated to advantage: and it is not of a lasting quality. Coal is preferable, for general purposes, to every other species of fuel; and besides its domestic application, its superiority for burning lime, that important source of fertility, or calcareous clay, also of much value to the farmer, is an object of great moment. The tenant, therefore, who resides in the neighborhood of coal, more especially if limestone or calcareous substances are at no great distance, farms at less expense, can afford to pay a higher rent, and may derive more profit from the land he cultivates, than if in these respects he were differently circumstanced.

#### SECT. VIII. *Of the Extent of Land suitable for a Farm.*

4416. *The extent of ground which a farmer proposes to occupy, demands due consideration.* If it be beyond his capital to cultivate or improve, he can derive no profit by taking it. On the other hand, a small occupation may not be worthy of his attention.

4417. *Farms as to size may be divided into three sorts*: small farms under 100 acres; moderate-sized farms, from 100 to 200 acres; large farms, from 200 to 1000 acres, and upwards, of land fit for cultivation. The expense of labor is now so great, and the rent of land so high, that the profits of a small farm are not sufficient, with the utmost frugality, or even parsimony, to maintain a family with comfort.

4418. *Moderate-sized farms* are well calculated for the dairy system, for the neighborhood of large towns, and where capital is not abundant. There are few trades, in which a small capital can be employed to a greater advantage than in a dairy farm, yet there is no branch of agriculture where such constant and unremitting attention is required. That is not to be expected from hired servants; but it is in the power of the wives and daughters of the farmer to perform, or at any rate to superintend, the whole concern, without whose aid it cannot be rendered productive.

4419. *Moderate-sized farms* are general in the neighborhood of towns. This necessarily results from the high rents paid in such situations; the shortness of the leases usually granted of land near towns; and the necessity the farmer is under, of selling, in small quantities, the articles produced on his farm. On this subject it has been remarked, that farmers in the vicinity of large towns resemble retail shopkeepers, whose attention must be directed to small objects, by which a great deal of money is got, the greater part of which would be lost, without the most unremitting attention. The farmer at a distance from markets, who cultivates on a great scale, may be compared, on the other hand, to a wholesale trader, who, as his profits are less, requires a greater extent of land, for the purpose both of engaging his attention, and of enabling him to support that station of life in which he is placed. There is this difference also between farmers in the neighborhood of towns, and those who reside at a distance from them, that the former find it more profitable to sell their produce, even such bulky articles as turnips, potatoes, clover, hay, and straw, than to fatten cattle for the butcher; and they are enabled to do so, without injury to their farms, as they can procure dung in return.

4420. *Farms of the largest size* differ in respect to the capital required. A mountain breeding farm of 5000 acres will not require more to stock it than an arable farm of 500 acres, and much less expense of labor to carry it on. In all cases the safe side for the farmer to lean to, is to prefer a farm rather under than exceeding his capital: and let him consider well beforehand whether he is going to commence a retail farmer for

daily markets, or a manufacturer of produce on a large and ample scale ; for the spirit, attention, and style of living of the one differs materially from that of the other.

SECT. IX. *Of the Tenure on which Lands are held for Farming.*

4421. *Perpetual tenures*, or absolute property in land, can never come into consideration with a farmer looking out for a farm. A proprietor cultivating his own property cannot, in correct language, be said to be a farmer, for to constitute the latter an essential requisite is the payment of rent.

4422. *The leases* on which lands are let for farming, are for various terms and with very different covenants. The shortest lease is from year to year, which unless in the case of grass lands in the highest order, and of the richest quality, or in some other very peculiar circumstances, no prudent man, whose object was to make the most of his skill and capital, would accept of. Even leases for seven or ten years are too short for general purposes ; fourteen or fifteen years seems to be the shortest period for arable lands so as to admit of the tenant paying a full rent ; but fourteen years, when the lands to be entered on are in bad condition, is too short a period, and twenty-one years much better for the true interest of both parties. In farming, however, as in every other occupation where there is more skill and capital in want of employment than can find subjects to work on, farms will be taken under circumstances, both in regard to leases and rent, that are highly unfavorable to the farmer ; and if they do not end in his ruin will keep him always poor, and probably not only pay less interest for his capital than any other way in which he could have employed it, but also infringe on its amount. The rapid depreciation of currency which took place in Britain during the wars against the French deceived many farmers, and flattered them for a time with the gradual rise of markets year after year. However high land might be taken at the commencement of a lease, it was always considered a consolation that it would be a bargain by the time it was half done ; and that the farmer's fortune would be made during the last few years of its endurance. When the currency of Britain was permitted to find its level with that of other countries, the delusion ceased, and the majority of farmers partially or wholly ruined.

4423. *In regard to the covenants of a lease*, it is necessary that there should be such in every one as shall protect both landlord and tenant. Certain general covenants in regard to repairs, renewals if necessary, timber, minerals, entry and exit crops, are common to all leases. Regulations as to manure are required where hay and straw, and other crops, are sold not to be consumed on the farm. Water meadows, rich old grass lands, copse woods, hop grounds, orchards &c., require special covenants. Fewest covenants are required for a mountain breeding farm ; and in all cases there should be a clause entitling the tenant to an appeal, &c. and a hearing from the landlord, and perhaps a jury of landlords or agents and farmers, against covenants as to cropping, repair, or renewals, which may, from extraordinary circumstances, press particularly heavy on the tenant.

4424. *The power of the landlord to grant a lease*, with liberal conditions, may in some cases be required to be ascertained by the tenant ; and in Scotland, where it is illegal to sublet a farm unless a clause to that effect has been asserted in the original lease, a farmer may cease to be the master of his own property, unless he has taken care to see that clause inserted. In England, as in every country where the laws are founded in equity, subletting a farm is no more prohibited than subletting a dwelling-house or a shop.

SECT. X. *Of Rent.*

4425. *The rent of land*, in a general point of view, must always depend on a variety of circumstances ; as the wealth of the country ; its population ; the price of produce ; the amount of public and other burdens ; the distance from markets ; the means of conveyance ; the competition among farmers ; and other less important considerations ; but the rent of any particular farm must be regulated by the nature of the soil ; the duration of the tenure, and the covenants contained in the lease ; the capital to be invested by the farmer in its culture ; and the expenses to which he is liable.

4426. *The rent of poor land* cannot possibly be the same as in the case of fertile lands. The labor of ploughing, harrowing, sowing, &c. when the land is in cultivation, is nearly the same, and yet the produce is greatly inferior, not only in quantity, but in quality. Indeed, where the produce is inconsiderable, or the quality much inferior, the whole, or nearly the whole, may be swallowed up by the expense of labor, and no rent whatever can be afforded, more especially in adverse seasons.

4427. *The duration of the tenure* must have a considerable effect in fixing the rent. No farmer can afford to pay the same sum for land on a short, as if he held it on a long lease. The covenants, also, which are in fact a species of rent, must influence the money payments.

4428. *Rent must also depend on the capital invested in the cultivation of the farm.*

Thus, if a farmer can lay out only 4*l.* of capital per acre, he may not be able to afford for it a higher rent than 10*s.* per acre; if he lays out 7*l.* he may pay 14*s.*; and with a capital of 10*l.* per acre, he may be enabled to pay 18*s.* or 20*s.* of rent.

4429. *The proportion of produce which should be paid as rent*, is a question that has long been considered as abstruse, mysterious, and very difficult to resolve. Some have supposed, that one-fifth was a reasonable proportion, while others contend for a fourth, or even a third part of the produce of arable land. But all former calculations on this subject are rendered fallacious by the effects of modern improvements. The rent ought certainly to depend upon the amount of the disposable produce; and that produce in grain is greatly augmented, both by a diminution of the consumption on the farm, effected by improved implements, and a more correct arrangement of labor, and likewise a better cultivation of the land in tillage. Hence, while the price of wheat has greatly advanced during the last twenty years, above the average price of the preceding twenty, the rent of land has not only risen, but in a higher proportion. More grain, and that of a better quality, has been produced on the same extent of land, and a greater amount of disposable surplus has gone to market. Out of this surplus disposable produce, it is evident, that the rent must be paid. But it is difficult to divide its amount between the landlord and tenant, as so much depends upon the seasons, and on the prices of the different articles which the farm produces. In bad seasons also, every deficiency of produce, in the acres set apart for supporting home population, must be made up from the disposable surplus; nor is it possible to apply the same rules to all situations, soils, and climates, in all the various districts of an extensive country. It may be proper, however, to give some general idea of the proportion of produce paid as rent, in Scotland, and in England.

4430. *In Scotland*, the following table states what is considered to be a fair proportion, where the land is cultivated :

	<i>Per acre.</i>
Where land produces 10 <i>l.</i> 10 <i>s.</i> per acre per annum, one-third, or	- £ 3 11 0
Where land produces 6 <i>l.</i> 12 <i>s.</i> per annum, one-fourth, or	- 1 13 0
Where land produces only 4 <i>l.</i> 5 <i>s.</i> per acre, one-fifth, or	- 0 17 0

4431. *In regard to grazing farms*, they are let on principles totally different from the arable; namely, according to the quantity of stock they can maintain; and as they are not liable to the same expense of management, both the landlord and the tenant receive larger shares of the produce than in the case of arable farms.

4432. *In England*, the tenant is allowed, on arable land, what is considered to be one moiety of the surplus, after defraying the expenses of cultivation, the taxes to which he is liable, and every other outgoing. Hay land requires much less of his attention, and for this he only obtains one-third of the surplus. But the profits of grazing, depending much on superior judgment in buying and selling stock, as well as skill in preventing, or curing their diseases, the grazier is entitled to a share of the surplus, fully equal to that of his landlord. It has been contended, as a general principle, that as both the expense of cultivating land, and the value of its produce, are infinitely various, a farmer ought to calculate what profit he can make on his whole farm, without entering into details; it being of little consequence to him, whether he pays at the rate of 10*l.* or 10*s.* per acre, provided he makes an adequate interest on the capital invested. That is certainly a fair criterion on which a tenant may calculate what he ought to offer; but a landlord, in estimating the rent he ought to insist on, will necessarily take into his consideration, the produce that his land is capable of yielding, and what proportion of it, or of its value, at a fair average, he has reason to expect, under all the circumstances of the case.

4433. *What the profits are to which a farmer is entitled*, is a subject of much dispute. On the one hand it is contended, that the produce of land is of such universal and absolute necessity to the existence of mankind, that it is not reasonable it should yield to him who raises it, more than a fair profit. On the other hand it is urged, that a farmer is entitled to be fully recompensed for the application of a considerable capital, exposed to the uncertainty of the seasons, when it is managed with economy, and conducted with industry and skill; and it has also been observed, that it is seldom more money is got by farming, than an adequate interest for the capital invested. This is owing to competition, the articles produced being in numberless hands, who must bring them to market; and necessity, the goods of the farmer being in general of a perishable nature, on the sale of which he depends, for the payments he has to make, and the subsistence of his family. To prove how moderate the profits of farming in general are, it appears from the most careful inquiries, that on arable farms they rarely exceed from ten to fifteen per cent. on the capital invested, which is little enough, considering that few employments are more subject to casualties than farming, or require more uniform attention. Some arable farmers, possessed of superior skill and energy, and who have got leases on reasonable terms, may clear from fifteen to twenty per cent.,

while others, who are deficient in these qualities, or pay too high rents, frequently become insolvent. Certain it is, that the great majority of farmers merely contrive to live and bring up their families; adding little or nothing to their capital, but that nominal addition which takes place in consequence of the depreciation of the currency.

4434. *In grazing farms* the case is different, as they are attended with less expense of labor, and produce articles of a more luxurious description, for which a higher price will be given. Hence, in such farms, fifteen per cent. and upwards, is not unusual. Besides, the grazier is more of a trader than the mere arable farmer; is frequently buying as well as selling stock, and sometimes makes money by judicious speculations, though occasionally, from a sudden fall of stock, his losses are considerable. The grazier who breeds superior stock, and thence incurs great expense, is certainly well entitled to more than common profit for his skill and attention.

4435. In regard to *the mode in which rent should be paid*, it is proper to consider, whether the whole, or at least part of the rent, ought not to depend upon the price of grain, not for the season, but on an average of a certain number of years preceding that for which the rent is due. By this plan, neither the landlord nor the tenant can suffer from the fluctuating price of grain, whereas, without some such arrangement, the tenant, on the one hand, cannot make a fair offer of rent, lest the price of grain should fall too low; nor on the other hand, can the landlord grant a lease of considerable duration, lest the price of grain should, in the progress of time, rise much higher. It seems therefore to be for the interest of both parties, that on arable farms a part of the rent should be payable in money and part in corn, and not in kind, but in money, according to the average value of a number of years. This plan is enforced by law to the extent of one-third in college leases, and thus an income is secured in some degree proportioned to the value of money. It is not, however, without its difficulties. The amount of rent for improvable and well cultivated farms, does not depend so much on the price of grain as is commonly imagined. A large proportion of such farms usually produce green crops, the value of which depends upon the prices of beef, mutton, and wool, and not on that of grain. Various circumstances also may arise, which may reduce the price of particular sorts of grain below its usual level, (for example, barley, when the distilleries are stopped); or may raise it disproportionately much higher, in case a large proportion of the wheat crop should be destroyed by rust or mildew. But if the proposed payment, by the conversion of corn into money, be extended to the various sorts of grain usually cultivated in the district, and be restricted to one-half of the rent, it does not seem liable to any material difficulty. If the payment also depends on the average of seven or more years, the main objection to a corn rent, that the farmer is often liable to pay the most when he is the least able to do it, is removed. (See 4327.)

4436. *The periods of payment* ought to be made so convenient to the tenant, that he may not be under the necessity of selling the produce of his farm to disadvantage, for the sake of ready money (4340.), nor should he be compelled to pay his rent out of his capital, for that would cripple all his future exertions. The periods should vary according to the nature of the occupation, and the time when the tenancy commenced. On the whole, the most successful farmers are those, who embark a capital sufficiently large in their undertaking; who feel it their duty to watch over that capital with unceasing care, and to add to it whenever it is practicable; and who have agreed to pay a fair, but not a speculative rent, for the lands they cultivate.

#### SECT. XI. *Of Taxes and other Burdens which affect the Farmer.*

4437. *Farmers are subjected to the payment of various taxes besides the rent paid to the landlord*; some of them imposed for local purposes, and others for the general expenses of the state. The real amount of such burdens, every careful tenant ought accurately to know, before he bargains for his lease. They may be classed under the following heads: parochial, national, and miscellaneous.

4438. *Parochial taxes* are for the support of the clergyman, for the maintenance of the poor, and in Scotland, for providing a parochial schoolmaster. The mode of supporting the clergy in England, by paying them a tenth part of the produce of the land in kind, is highly injurious to agriculture, and a bar to improvement. It is a great bar to improvement, because an improving farmer, one more enlightened or more spirited than his neighbors, would pay more tithe by means of his outlay and exertions, but it is not certain that he would likewise receive more profit. The produce would be more, but the expense would be greater. Nothing can be more obnoxious than a law, by which, when a person expends a large sum, either in reclaiming wastes, or augmenting the fertility of land already cultivated, he should be under the necessity of yielding up one-tenth of its produce to a person who has been liable to no share of the expense, who has run none of the risk, and who has sustained none of the labor attending the improvement. A commutation of tithe, therefore, instead of its being exacted in kind, would be one of the greatest benefits that could be conferred on agriculture; and there



is not the least difficulty in effecting it, by giving to the tithe-owner, either a proportion of the land, or by converting the tithe into a perpetual corn rent. Both these plans have been adopted in a variety of cases, by local acts in England, and they ought now to be enforced as a general system.

4439. *An assessment for the maintenance of the poor*, is another parochial burden, which is annually increasing, and which, if not speedily regulated upon proper principles, will inevitably absorb a very large proportion of rent in England. Indeed, there are instances, where between the years 1815 and 1822, it has absorbed the whole. This tax is the most dangerous of all for the farmer, on account of its fluctuation, and indeed, it may be said that it never falls but continually rises. During infancy, in sickness, and in old age, assistance may be necessary; but, as Malthus justly observes, the poor-laws hold out support to the vicious and idle, at the expense of the prudent and the industrious. These payments also destroy the spirit of independence, and those ideas of honest pride which stimulate a man to use his utmost exertions in support of himself and his family; and on its present footing, the boon is administered by the parish officers with caution and reluctance, and received by the poor with dissatisfaction and ingratitude.

4440. *In Scotland, the poor are in general maintained by voluntary contributions*; but when these are not found to be sufficient, the proprietors of the parish, with the clergyman and vestry, or kirk-session, are directed to make a list of the indigent persons in the parish, and then to impose an assessment for their relief, one half to be paid by the proprietors, and the other half by the tenantry.

4441. *The national burdens in general*, as the duties on houses and windows, and other assessed taxes; or assessments for the support of militia-men's wives and families, for the conveyance of vagrants, or the prosecution of felons, fall no heavier upon the farmer, than upon other classes of the community; but there is one impost which is severely felt by the arable farmer, namely, the tax on horses employed in husbandry. The inequality of that tax is strongly objected to; for lands, when pastured, and necessarily subject to the least expense, pay no part of it. The burden consequently falls exclusively on the lands in tillage, which, as a necessary consequence, must prevent the farmer from giving so high a rent on arable land as he would on grass land, in proportion to the produce.

4442. There are likewise *various miscellaneous burdens* affecting the farmer, as statute assessments for bridges, which are of such public utility, that moderate rates for their maintenance properly applied, cannot be objected to; statute labor on the highways; constable dues, which are seldom of much moment; charges of the churchwardens, including the repairs of the church; and in some populous parishes, there is sometimes a burial-ground tax. All these are paid by the occupiers. In some places also, there is a sewer's tax, chargeable on the landlords, where it is not otherwise settled by express contract. Adstriction to mills, however, is the severest burden where it exists, for not only is the expense of grinding double or treble what ought to be exacted, but the farmer is bound to carry his grain to be manufactured by a person, in whose skill or honesty he cannot always place any dependence.

4443. *As an example of the payments made by a farmer in England, whose rent is annually 500*l.** the following is submitted:

Tithes are compounded for at	- - - - -	£100 0 0
Poor's assessment is 5 <i>s.</i> on the pound	- - - - -	125 0 0
Church assessment	- - - - -	6 5 0
Highway assessment	- - - - -	13 10 0
House tax and window tax	- - - - -	10 0 0
Horse tax and dog tax	- - - - -	7 10 0
Stamped receipts for these and other payments	- - - - -	1 15 0

The whole are very nearly 53 per cent., or - - - - - £264 0 0

4444. *The vexations* to which farmers in England are subjected, from various uncertain burdens, operates as a premium to Scottish agriculture. It is ingeniously and justly remarked, that physical circumstances are much more favorable to agriculture in England, than in her sister country; but these advantages are counteracted by the accumulation of moral evils, which might be removed if the legislature were to bestow on matters connected with the internal improvement of the country, and the means for promoting it, a portion of that attention, which it so frequently gives to the amelioration or improvement of our foreign possessions.

#### SECT. XII. *Of other Particulars requiring a Farmer's Attention, with a view to renting of Land.*

4445. *A variety of miscellaneous particulars* require consideration, before a prudent farmer will finally resolve to undertake the cultivation of a farm; as, the nature of the property on which the farm is situated; in particular, whether the estate is entailed, and to what extent the possessor of the estate is authorized to grant a lease; the character of the landlord, and in case of his decease, that of his family, and of those whom they are likely to consult; the real condition of the farm in regard to the enclosures, drainage, buildings, &c.; the crops it has usually produced, and the manner in which it has been managed for some

years preceding; the general state of the district, in regard to the price of labor, and the expense of living; the character of its inhabitants, in particular of the neighboring farmers and laborers; and whether they are likely to promote or to discourage a spirit of improvement; the probability of subletting to advantage in case of not liking the situation, finding a better bargain, or of death. The chances of settling one's family; as of marrying daughters, or of sons' making good marriages. The social state of the farmers, or those that would be considered one's neighbors; the number and tone of clergy, and lawyers; the game, and the chances of disputes concerning it; the morals of the serving class; schools, places of worship, &c. It is evident, that in hardly any one instance can all the circumstances above enumerated be favorably combined. But the active and intelligent farmer will not be discouraged by the obstacles he may have to surmount; but will strenuously endeavor, by exertion, industry, and perseverance, to overcome the difficulties he must unavoidably encounter,

---

## CHAP. II.

*Considerations respecting Himself, which a Farmer ought to keep in view in selecting and hiring a Farm.*

4446. *Whoever intends to embrace farming as a profession, will be less likely to meet with disappointment, if he previously examines a little into his own disposition and talents; and weighs his expectations against ordinary results. Nor is it less essential that he should estimate justly the extent to which his capital may be adequate, and keep regular accounts.*

### SECT. I. *Of the personal Character and Expectations of a professional Farmer.*

4447. *Every one who proposes to farm with success, Professor Thaer observes, ought to unite energy and activity, to reflection, to experience, and to all necessary knowledge. It is true, he says, farming has long been considered as an occupation fit for a young man incapable for any other, and such have sometimes succeeded; but this has always been chiefly owing to a fortunate concurrence of circumstances, which it is not now very easy to meet with.*

4448. *The practice of agriculture consists of an infinite number of particular operations, each of which appears easy in itself; but is often for that very reason the more difficult to execute to the precise extent required; one operation so often interferes with another. To regulate them according to the given time and strength, and in such a way that none is neglected, or causes the neglect of others, requires at once a great deal of attention and activity, without inquietude; of promptitude without precipitation; of general views, and yet with an extreme attention to details.*

4449. *To casualties and accidents, no business is so much exposed as farming, and therefore to enjoy an ordinary degree of happiness, Professor Thaer considers it essential that the farmer possess a certain tranquillity of mind. This, he says, may either be the result of a natural phlegmatic habit of body, or of elevated views in religion, or philosophy. These will enable him to bear with every misfortune arising from adverse seasons, or the death of live stock; and only permit him to regret accidents which result from his own neglect.*

4450. *The expectations of profit and happiness which a young farmer has formed ought to be well weighed against the profits and happiness of farmers in general. However superior a farmer may consider his own talents and abilities, he may rest assured there are a number as skilful and adroit as himself, and just as likely to realize extraordinary advantages. Let none therefore engage in farming, thinking to make more money than other farmers similarly circumstanced with himself. If from a happy concurrence of circumstances he is more than usually successful, so much the better, and let him consider it as partly owing to good fortune as well as good farming; but never let him set out on the supposition of gaining extraordinary advantages with only ordinary means.*

4451. *The profits of farming are much exaggerated by people in general: but it may be asserted as an unquestionable fact, that no capital affords less profit than that employed in farming, except that sunk in landed property. This is the natural result both of the universality of the business and of its nature. Farming is every where practised, and every one thinks he may easily become a farmer; hence high rents, which necessarily lessen the profits on capital. From the nature of farming the capital employed is seldom returned. A tradesman may lay out and return his capital several times a year; but a farmer can never, generally speaking, grow more than one crop per annum. Suppose he succeeds in raising the best possible crops in his given circum-*

stances, still his profits have an absolute limit: for if an ordinary crop be as five, and the best that can be grown be as seven, all that the most fortunate concurrence of circumstances will give is not great and easily foreseen. It is hardly possible for a farmer, paying the market price for his land, to make much more than a living for himself and family. Those few who have exceeded this, will be found to have had leases at low rents; indulgent landlords; to have profited by accidental rises in the market or depreciation of currency; or to have become dealers in corn and cattle: and rarely indeed to have realized any thing considerable by mere good culture of a farm at the market price. Very different is the case of a tradesman, who, with the properties which we have mentioned as requisite for a good farmer, seldom fails of realizing an independency.

4452. *Many persons, chagrined with a city life, or tired of their profession, fancy they will find profit and happiness by retiring to the country and commencing farming.* Independently of the pecuniary losses attending such a change, none is more certain of being attended with disappointment to the generality of men. The activity required, and the privations that must be endured, are too painful to be submitted to; whilst the dull uniformity of a farmer's life to one accustomed to the bustle of cities, becomes intolerable to such as do not find resources in their fire-sides, their own minds, or, as Professor Thaer observes, in the study of nature.

4453. *The most likely persons to engage in farming with success, are the sons of farmers, or such others as have been regularly brought up to the practice, with their own hands, of every part of agriculture.* They must also have an inclination, as well as competent understanding of the theory or principles of the art. Books are to be found every where, from which the science of the art is to be obtained; and there are eminent farmers in the improved districts who take apprentices as pupils. In *The Husbandry of Scotland*, the case is mentioned of Walker, of Mellendean, an eminent farmer in Roxburghshire, who rents about 2866 acres of arable land, and is distinguished for his skill in agriculture, who takes young men under him as apprentices, who, instead of receiving wages, have uniformly paid him ten pounds each. Some of them remain with him two years, but the greater number only one. They eat in his kitchen, where they have always plenty of plain wholesome food. He takes none who are above living in that way, or who will not put their hand to every thing going forward on the farm. He has sometimes been offered ten times the above sum, to take in young gentlemen to eat and associate with his own family, but that he has uniformly declined. These young men have an opportunity of attending to every operation of husbandry, as practised on Walker's farm; and are taught to hold the plough, to sow, to build stacks, &c.

#### SECT. II. *Of the Capital required by the Farmer.*

4454. *The importance of capital in every branch of industry is universally acknowledged, and in none is it more requisite than in farming.* When there is any deficiency in that important particular, the farmer cannot derive an adequate profit from his exertions, as he would necessarily be frequently obliged to dispose of his crops for less than their value, to procure ready money; and it would restrain him from making advantageous purchases, when even the most favorable opportunities occurred. An industrious, frugal, and intelligent farmer, who is punctual in his payments, and hence in good credit, will strive with many difficulties, and get on with less money, than a man of a different character. But if he has not sufficient live stock to work his lands in the best manner, as well as to raise a sufficient quantity of manure; nor money to purchase the articles required for the farm, he must, under ordinary circumstances, live in a state of penury and hard labor; and the first unfavorable season, or other incidental misfortune, will probably sink him under the weight of his accumulated burdens. Farmers are too generally disposed to engage in larger farms than they have capital to stock and cultivate. This is a great error; for it makes many a person poor upon a large farm, who might live in comfort and acquire property, upon one of less extent. No tenant can be secure without a surplus at command, not only for defraying the common expenses of labor, but those which may happen from any unexpected circumstance. When a farmer, on the other hand, farms within his capital, he is enabled to embrace every favorable opportunity of buying when prices are low, and of selling when they are high.

4455. *The amount of capital required must depend upon a variety of circumstances; as whether it is necessary for the farmer to expend any sum in the erection, or in the repair of his farm-house and offices; what sum an in-coming tenant has to pay to his predecessor, for the straw of the crop, the dung left upon the farm, and other articles of similar nature; the condition of the farm at the commencement of the lease, and whether any sums must be laid out in drainage, enclosure, irrigation, levelling ridges, &c.; whether it is necessary to purchase lime, or other extraneous manures, and to what extent; on*

the period of entry, and the time at which the rent becomes payable, as this is sometimes exacted, before there is any return from the lands, out of the actual produce of which it ought to be paid; and, lastly, on its being a grazing, or an arable farm, or a mixture of both.

4456. *In pasture districts*, the common mode of estimating the amount of capital necessary, is according to the amount of the rent; and it is calculated, that in ordinary pastures, every farmer ought to have at his command, from three to five times the rent he has agreed to pay. But in the more fertile grazing districts, carrying stock worth from 20*l.* to 30*l.* and even upwards, per acre, (as is the case in many parts of England,) five rents are evidently insufficient. When prices are high, ten rents will frequently be required, by those who breed superior stock, and enter with spirit into that new field of speculation and enterprise.

4457. *The capital required by an arable farmer* varies, according to circumstances, from 5*l.* to 10*l.* or even 15*l.* per acre. An ignorant, timid, and penurious farmer lays out the least sum he can possibly contrive; and consequently he obtains the smallest produce or profit from his farm. These, however, will always increase, when accompanied by spirit and industry, in proportion to the capital employed, if judiciously expended. At the same time, attention and economy cannot be dispensed with. It is ill-judged to purchase a horse at forty guineas, if one worth thirty can execute the labor of the farm; or to lay out sums unnecessarily upon expensive harness, loaded with useless ornaments. Prudent farmers also, who have not a large capital at command, when they commence business, often purchase some horses still fit for labor, though past their prime, and some breeding mares, or colts; and in five or six years, they are fully supplied with good stock, and can sometimes sell their old horses without much loss. In every case, such shifts must be resorted to, where there is any deficiency of capital.

4458. *A mixture of arable and grass farming* is, on the whole, the most profitable method of farming. Independently of the advantages to be derived from the alternate husbandry (which are always considerable), the chances of profit are much more numerous from a varied system, than where one object is exclusively followed. Where this mixed mode of farming is practised, the farmer will frequently rely on the purchase of lean stock, instead of breeding his own; and derives great advantage from the quickness with which capital thus employed is returned. But, in that case, much must depend upon judicious selection. In general it may be said, that to stock a turnip-land arable farm, will require, at this time (1823), 5*l.* or 6*l.* and a clay-land farm from 7*l.* or 8*l.* per acre, according to circumstances.

4459. *This capital is necessarily divided into two parts.* The one is partly expended on implements, or stock of a more or less perishable nature, and partly vested in the soil; for this the farmer is entitled to a certain annual gain, adequate to replace, within a given number of years, the sum thus laid out. The other is employed in defraying the charges of labor, &c. as they occur throughout the year; the whole of which, with the interest, should be replaced by the yearly produce. These two branches of expense on a farm are the first to be attended to, both in order of time, and in magnitude of amount.

4460. *The most satisfactory statement hitherto given of the profit* derived from the expenditure of an adequate capital in arable farming, is that furnished by George Rennie, Esq. of Phantassie, in East Lothian. On a mixed soil of 702 English acres, he states the profits at 1*l.* 5*s.* per English acre, or about 14 per cent. on the capital employed. Rennie is one of the very first practical agriculturists in Scotland, and has been so successful as to purchase the farm which he occupies. (*Code, &c.* p. 70—73.)

---

### CHAP. III.

#### *On the Choice of Stock for a Farm.*

4461. *The stocking of a farm* may be considered as including live stock, implements, servants, and seed. A considerable portion of a farmer's capital is employed in manures, tillages, labor, &c. but a farm being once engaged, the above are the only descriptions of stock which admit of a choice.

#### SECT. I. *Of the Choice of Live Stock.*

4462. *The animals required by a farmer* are of two kinds; such as are employed to assist in labor, and such as are used to convert the produce of the farm into food, or other disposable commodities.

SUBJECT. 1. *Live Stock for the Purposes of Labor.*

4463. *The animals of labor used in British farming* are exclusively the horse and the ox. Much difference of opinion formerly prevailed, as to which of these two animals should be preferred, and the preference has generally been given by speculative writers to the ox, and by practical farmers to the horse. Lord Kaimes in the last century, and Lord Somerville in the present, may be considered the principal advocates for the ox. To their arguments, and to all others, the following objections have been stated by the able author of the supplement to the 6th edition of *The Gentleman Farmer*; and they may be considered as conveying the sentiments, and according with the practice of all the best informed, and most extensive British farmers.

4464. *The first objection to oxen* is, that they are unfit for the various labors of modern husbandry, — for travelling on hard roads in particular, — for all distant carriages, — and generally for every kind of work which requires dispatch: and what sort of work often does not in this variable climate? A great part of a farmer's work is indeed carried on at home, and it may still be thought that this may be done by oxen, while one or more horse-teams are employed in carrying the produce to market, and bringing home manure and fuel. But it is unnecessary to appeal to the author of *The Wealth of Nations*, to prove the impracticability of this division of labor, unless upon very large farms; and even on these the advantages of such an arrangement are at best extremely problematical. The different kinds of farm-work do not proceed at the same time; but every season, and even every change of weather, demands the farmer's attention to some particular employment, rather than to others. When his teams are capable of performing every sort of work, he brings them all to bear for a time upon the most important labors of every season; and when that is dispatched, or interrupted by unfavorable weather, the less urgent branches are speedily executed by the same means. This is one cause, more important perhaps than any other, why oxen have ceased to be employed; for even ploughing, which they can perform better than any other kind of work, is scarcely ever going forward all the year; and for some months in winter, the weather often prevents it altogether.

4465. *Another objection* is, that an ox team capable of performing the work of two horses, even such kind of work as they can perform, consumes the produce of considerably more land than the horses. If this be the case, it is of no great importance, either to the farmer or the community, whether the land be under oats, or under herbage and roots. The only circumstance to be attended to here, is, the carcass of the ox: the value of this, in stating the consumption of produce, must be added to the value of his labor. He consumes, from his birth, till he goes to the shambles, the produce of a certain number of acres of land; the return he makes for this is so much beef, and so many years' labor. The consumption of produce must therefore be divided between these two articles. To find the share that should be allotted to each, the first thing is to ascertain how many acres of grass and roots would produce the same weight of beef from an ox, bred and reared for beef alone, and slaughtered at three or four years' old. What remains has been consumed in producing labor. The next thing is to compare this consumption with that of the horse, which produces nothing but labor. By this simple test, the question, viewing it upon a broad national ground, must evidently be determined. Every one may easily make such a calculation suited to the circumstances of his farm; none that could be offered would apply to every situation. But it will be found, that if even three oxen were able to do the work of two horses, the advantages in this point of view would still be on the side of the horses; and the first objection applies with undiminished force besides.

4466. *The money-price of the horse and ox*, it is evident, is merely a temporary and incidental circumstance, which depends upon the demand. A work ox may be got for less than half the price of a horse, because there is little or no demand for working oxen, while the demand for horses by manufactures, commerce, pleasure, and war, enhance the price of farm-horses, as well as of the food they consume. Those who wish to see horses banished from all sorts of agricultural labor, would do well to consider where they are to be reared for the numerous wants of the other classes of society. Besides, if two oxen must be kept for doing the work of one horse, it ought to be foreseen, that though beef may be more abundant than at present, there will be a corresponding deficiency in the production of mutton and wool. A greater portion of the arable land of the country must be withdrawn from yielding the food of man directly, and kept under cattle crops, which, however necessary to a certain extent for preserving the fertility of the soil, do not return human food, on a comparison with corn-crops, in so great a proportion as that of one to six from any given extent of land of the same quality.

4467. *The demand for oxen is confined almost every where to the shambles*; and by the improvements of modern husbandry, they are brought to a state of profitable maturity at an early age. No difference in price at setting to work, — no increase of weight while working, — no saving on the value of the food consumed, can ever make it the interest of tillage farmers generally, to keep oxen as formerly, till they are eight or ten years old. They judiciously obtain the two products from different kinds of animals, each of them from the kind which is best fitted by nature to afford it, — the labor from the horse, and the beef alone from the ox. And though the price of the horse is almost wholly sunk at last, during the period of his labor he has been paying a part of it every year to a fund, which, before his usual term expires, becomes sufficiently large to indemnify his owner. The ox, on the other hand, is changed three or four times during the same period; and each of them gives nearly as large a carcass for the food of man, as if his days had been unprofitably prolonged in executing labor, from which he has been gradually exempted in Britain, in France, and in other countries, very nearly in proportion to the progress of correct systems of husbandry.

4468. *The description of horse* which a farmer ought to choose will depend chiefly on the soil of the farm, and partly also on the quantity of road-work. Stiff lands require obviously a heavier and more powerful breed than such as are light and hilly. In the latter case, two of the best breeds are the Clevelands and Clydesdale, or some local cross with these breeds. In general, it is not advisable to procure horses from a climate materially different from that where they are to remain; and therefore, for various reasons, a prudent farmer will look out for the best in his neighborhood. Often, however, he is

obliged to take the stock of his predecessor, and this he can only get rid of or improve to his mind by degrees. The farm-horses in most parts of England are much too cumbersome and heavy, and are more fitted for drawing heavy drays or waggons in towns, than for the quick step required in the operations of agriculture.

4469. *The objections of Davis of Longleat to the using of large heavy-heeled horses, in preference to the smart, the active, and the really useful breeds, merit particular attention.* In some situations, the steepness of the hills and the heaviness of the soil require more than ordinary strength; but in such cases, he maintains, that it would be better to add to the number of horses, than to increase their size. Great horses not only cost proportionably more at first than small ones, but require much more food, and of a better quality, to keep up their flesh. The Wiltshire carter also takes a pride in keeping them as fat as possible; and their food (which is generally barley) is given without stint. In many instances, indeed, the expense of keeping a fine team of horses, amounts nearly to the rent of the farm on which they are worked. They are purchased young when two years old colts, and sold at five or six years of age for the London drays and waggons. The expense of their maintenance is very seldom counterbalanced by the difference of price, more especially as such horses are gently worked when young, that they may attain their full size and beauty. In ploughing light soils, the strength of a dray-horse is not wanted; and in heavy soils, the weight of the animal does injury to the land.

SUBSECT. 2. *Of the Choice of Live Stock for the Purposes of breeding or feeding.*

4470. *The most desirable properties of live stock destined for food are considered in The Code of Agriculture, in respect to size, form, a tendency to grow, early maturity, hardness of constitution, prolific properties, quality of flesh, a disposition to fatten, and lightness of offal.*

4471. *Before the improvements introduced by Bakewell, the value of an animal was entirely judged of by its bulk; and if a great size could be obtained, more regard was paid to the price the animal ultimately fetched, than to the cost of its food.* Of late, since breeders began to calculate with more precision, small or moderate-sized animals have been generally preferred, for the following reasons:—

4472. *Small-sized animals are more easily kept, they thrive on shorter herbage, they collect food where a large animal could hardly exist, and thence are more profitable.* Their meat is finer grained, produces richer gravy, has often a superior flavor, and is commonly more nicely marbled, or veined with fat, especially when they have been fed for two years. Large animals are not so well calculated for general consumption as the moderate-sized, particularly in hot weather; large animals poach pastures more than small ones; they are not so active, require more rest, collect their food with more labor, and will only consume the nicer and more delicate sorts of plants. Small cows of the true dairy breeds give proportionably more milk than large ones. Small cattle may be fattened solely on grass of even moderate quality; whereas the large require the richest pastures, or to be stall-fed, the expense of which exhausts the profit of the farmer. It is much easier to procure well-shaped and kindly-feeding stock of a small size than of a large one. Small-sized cattle may be kept by many persons who cannot afford either to purchase or to maintain large ones, and by whom the loss, if any accident should happen to them, can be more easily borne. The small-sized sell better; for a butcher, from a conviction that, in proportion to their respective dimensions, there is a greater superficies of valuable parts in a small than in a large animal, will give more money for two oxen of twelve stone each per quarter, than for one of twenty-four stone.

4473. *In favor of the large-sized, it is, on the other hand, contended, that without debating whether from their birth till they are slaughtered the large or the small one eats most for its size, yet on the whole the large one will pay the grazier or farmer who fattens him as well for its food; that though some large oxen are coarse-grained, yet where attention is paid to the breed (as is the case with the Herefordshire), the large ox is as delicate food as the small one; that if the small-sized are better calculated for the consumption of private families, of villages, or of small towns, yet that large cattle are fitter for the markets of great towns, and in particular of the metropolis; that were the flesh of the small-sized ox better when fresh, yet the meat of the large-sized is unquestionably more calculated for salting, a most essential object in a maritime and commercial country, for the thicker the beef the better it will retain its juices when salted, and the fitter it is for long voyages; that the hide of the large ox is of very great consequence in various manufactures; that large stock are in general distinguished by a greater quietness of disposition; that where the pastures are good, cattle and sheep will increase in size, without any particular attention on the part of the breeder; large animals are therefore naturally the proper stock for such pastures; that the art of fattening cattle, and even sheep, with oil-cake, being much improved and extended, the advantage of that practice would be of less consequence, unless large oxen were bred, as small oxen*

can be fattened with grass and turnips, as well as oil-cake; and, lastly, that large oxen are better calculated for working than small ones, two large oxen being equal to four small ones in the plough or the cart.

4474. *Such are the arguments generally made use of on both sides of the question; from which it appears that much must depend upon pastures, taste, mode of consumption, markets, &c. and that both sides have their advantages. The intelligent breeder, however, (unless his pastures are of a nature peculiarly forcing,) will naturally prefer a moderate size in the stock he rears. Davis, of Longleat, one of the ablest agriculturists England has produced, has given some useful observations on the subject of size. He laments that the attempts which have been made to improve the breeds of cows, horses, and sheep, have proceeded too much upon the principle of enlarging the size of the animal; whereas, in general, the only real improvement has been made in the pig, and that was by reducing its size, and introducing a kind that will live hardier, and come to greater perfection at an earlier age.*

4475. *Though it is extremely desirable to bring the shape of cattle to as much perfection as possible, yet profit and utility ought not to be sacrificed for mere beauty which may please the eye but will not fill the pocket, and which, depending much upon caprice, must be often changing. In regard to form, the most experienced breeders seem to concur in the following particulars: — That the form or shape should be compact, so that no part of the animal should be disproportioned to the other parts, and the whole distinguished by a general fulness and rotundity of shape; that the chest should be broad, for no animal whose chest is narrow can easily be made fat; that the carcase should be deep and straight; that the belly should be of a moderate size; for when it is more capacious than common in young animals it shews a diseased state, and in older ones it is considered a proof that the animal will not return in flesh, in milk, or in labor, the value of the extra quantity of fruit which it consumes; that the legs should be short, for the long-limbed individuals of the same family or race are found to be the least hardy, and the most difficult to rear or to fatten; and that the head, the bones, and other parts of inferior value, should be as small as is consistent with strength, and with the other properties which the animal ought to possess. In animals bred for the shambles, the form must likewise be such as to contain the greatest possible proportion of the finer compared to the coarser and less valuable parts of the animal. This, by selection, may be attained, and thus the wishes of the consumer may be gratified. As to the broad loins and full hips, which are considered as a point of excellence in particular breeds, it is evident that the old narrow and thin make, required improvement; but the alteration is now carried to a faulty excess, and often occasions great difficulty and danger in calving.*

4476. *The form of animals has fortunately attracted the attention of an eminent surgeon, Henry Cline, Esq. of London, whose doctrines we have already laid down at length (1995.), and the substance of which is: — That the external form is only an indication of the internal structure; that the lungs of an animal is the first object to be attended to, for on their size and soundness the health and strength of an animal principally depend; that the external indications of the size of the lungs are the form and size of the chest, and its breadth in particular; that the head should be small, as by this the birth is facilitated; as it affords other advantages in feeding, &c. and as it generally indicates that the animal is of a good breed; that the length of the neck should be in proportion to the size of the animal, that it may collect its food with ease; and that the muscles and tendons should be large, by which an animal is enabled to travel with greater facility. It was formerly the practice to estimate the value of animals by the size of their bones. A large bone was considered to be a great merit; and a fine-boned animal always implied great size. It is now known that this doctrine was carried too far. The strength of an animal does not depend upon the bones, but on the muscles; and when the bones are disproportionately large, it indicates, in Cline's opinion, an imperfection in the organs of nutrition. Bakewell strongly insisted on the advantage of small bones; and the celebrated John Hunter declared that small bones were generally attended with corpulence in all the various subjects he had an opportunity of examining. A small bone, however, being heavier and more substantial, requires as much nourishment as a hollow one with a larger circumference.*

4477. Among the *qualities* for which thorough-bred cattle and sheep are distinguished, that of being good growers, and having a good length of frame, is not the least essential. The meaning of which is, that the animal should not only be of a strong and healthy constitution, but speedily should grow to a proper size. As specimens of rapid growth, a steer of three years old, when well fed, will weigh from 80 to 90 or 100 stone, 14lb. to the stone; and a two-year old Leicester wedder, from 25 to 28 lb. per quarter, immediately after his second fleece is taken from him. Animals having the property of growing, are usually straight in their back and belly; their shoulders well thrown back, and their belly rather light than otherwise. At the same time, a gauntness and paucity

of intestines should be guarded against, as a most material defect, indicating a very unthrifty animal. Being too light of bone, as it is termed, is also a great fault. A good grower, or hardy animal, has always a middling sized bone. A bull distinguished for getting good growers, is inestimable; but one whose progeny takes an unnatural or gigantic size, ought to be avoided.

4478. *Arriving soon at perfection*, not only in point of growth or size, but in respect of fatness, is a material object for the farmer, as his profit must in a great measure depend upon it. Where animals, bred for the carcass merely, become fat at an early age, they not only return sooner the price of their food, with profit to the feeder, but in general also, a greater value for their consumption, than slow-feeding animals. This desirable property greatly depends on a mild and docile disposition; and as this docility of temper is much owing to the manner in which the animal is brought up, attention to inure them early to be familiar, cannot be too much recommended. A tamed breed also has other advantages. It is not so apt to injure fences, or to break into adjacent fields; consequently it is less liable to accidents, and can be reared, supported, and fattened, at less expense. The property of early maturity, in a populous country, where the consumption of meat is great, is extremely beneficial to the public, as it evidently tends to furnish greater supplies to the market; and this propensity to fatten at an early age, is a sure proof, that an animal will fatten speedily at a later period of his life.

4479. In the wilder and bleaker parts of a country, *the possession of a hardy and healthy constitution*, is a most valuable property in stock. Where the surface is barren, and the climate rigorous, it is essential that the stock bred and maintained there, should be able to endure the severities and vicissitudes of the weather, as well as scarcity of food, hard work, or any other circumstance in its treatment, that might subject a more delicate breed to injury. In this respect, different kinds of stock greatly vary; and it is a matter of much consequence, to select, for different situations, cattle with constitutions suitable to the place where they are to be kept. It is a popular belief, that dark colors are indications of hardiness. In mountain breeds of cattle, a rough pile is reckoned a desirable property, more especially when they are to be kept out all winter. It enables them to face the storm, instead of shrinking from it. Hardy breeds are exempted from various diseases, such as having yellow fat, also being blackfleshed, defects so injurious to stock.

4480. *The prolific quality of a breed* is a matter deserving attention. The females of some breeds both bear more frequently than usual, and also have frequently more than one at a birth. This property runs more strikingly in sub-varieties, or individual families; and though partly owing to something in the habits of animals, and partly to their previous good or bad treatment, yet in some degree seems to depend upon the seasons, some years being more distinguished for twins than others. In breeding, not only the numbers, but the sex of the offspring, in some cases, seem to depend upon the female parent. Two cows produced fourteen females each in fifteen years, though the bull was changed every year. It is singular, that when they produced a bull calf, it was in the same year. Under similar circumstances, a great number of males have been produced by the same cow in succession, but not to the same extent.

4481. Breeds are likewise distinguished by *the quality of their flesh*. In some kinds it is coarse, hard, and fibrous; in others of a finer grain or texture. In some breeds also, the flavor of the meat is superior; the gravy they produce, instead of being white and insipid, is high colored, well flavored, and rich; and the fat is intermixed among the fibres of the muscles, giving the meat a streaked, or marbled appearance. Breeds whose flesh have these properties, are peculiarly valuable. Hence two animals of nearly the same degree of fatness and weight, and who could be fed at nearly the same expense to the husbandman, will sell at very different prices, merely from the known character of their meat.

4482. *A disposition to fatten* is a great object in animals destined for the shambles. Some animals possess this property during the whole progress of their lives, while in others, it only takes place at a more advanced period, when they have attained their full growth, and are furnished at the same time with a suitable supply of food. There are in this respect other distinctions: most sorts of cattle and sheep, which have been bred in hilly countries, will become fat on low land pastures, on which the more refined breeds would barely live; some animals take on fat very quickly, when the proper food has been supplied, and some individuals have been found, even in the same breed, which have, in a given time, consumed the least proportional weight of the same kind of food, yet have become fat at the quickest rate. Even in the human race, with little food, some will grow immoderately corpulent. It is probably from internal conformation, that this property of rapid fattening is derived.

4483. *The advantages and disadvantages of fattening cattle and sheep*, at least to the extent frequently practised at present, are points that have of late attracted much public



attention. But any controversy on that subject can only arise from want of proper discrimination. Fat meat is unquestionably more nourishing than lean, though to digest this oily matter, there are required, on account of its difficult solubility, a good bile, much saliva, and a strong stomach; consequently none, excepting those who are in the most vigorous state of health, or who are employed in hard labor, can properly digest it. Though fat meat, however, is unfit for general consumption, yet experiments in the art of fattening animals, are likely to promote useful discoveries; and though, in the course of trying a number of experiments, errors and excesses may be committed, yet on the whole, advantage may be derived from the knowledge thus to be obtained. As the bone also gains but little in the fattening animal, and the other offal becomes proportionably less, as the animal becomes more fat, the public has not sustained much loss by over-fatted animals. To kill even hogs till they are thoroughly fat, is exceeding bad economy. An ox or cow, though the little flesh it has may be of good quality, yet presents, when lean, little but skin and bone; and if slaughtered in that state would neither indemnify the owner for the expense of breeding and maintaining it, nor benefit the public. A coarse and heavy-fleshed ox, which would require a very long time, and much good food to fatten, may be slaughtered with most advantage while rather lean. It is not, however, so much the extent of fat, as the want of a sufficient quantity of lean flesh, of which the consumer complains; for it cannot be doubted, that the lean flesh of a fat animal is superior in quality, and contains more nourishment, than any other meat.

4484. *Handling well.* The graziers and butchers in various parts of the kingdom have recourse to the hand, and the feeling of the skin, or cellular membrane, for ascertaining a disposition to fatten; and since Bakewell directed the public attention so much to breeding, that practice has become more generally known. Handling cannot easily be defined, and can only be learnt by experience. The skin and flesh of cattle, when handled, should feel soft to the touch, somewhat resembling that of a mole, but with a little more resistance to the finger. A soft and mellow skin must be more pliable, and more easily stretched out, to receive any extraordinary quantity of fat and muscle, than a thick or tough one. The rigid-skinned animal must therefore always be the most difficult to fatten. In a good sheep, the skin is not only soft and mellow, but in some degree elastic. Neither cattle nor sheep can be reckoned good, whatever their shapes may be, unless they are first-rate handlers. The improved short-horned breed, besides their mellowness of skin, are likewise distinguished by softness and silkiness of hair. Too great a length, however, ought not to be aimed at, since it is not easy, in that case, to preserve a due proportion in the appearance of the animal, without which it cannot be considered perfect.

4485. *Lightness of offal.* An animal solely bred for the shambles, should have as little offal, or parts of inferior value, as possible (consistently with the health of the animal), and consequently a greater proportion of meat applicable as food for man. This, therefore, the skilful farmer will also keep in view in selecting his species of stock. (*Code, &c.*)

## SECT. II. *Of the Choice of Agricultural Implements, Seeds and Plants.*

4486. *The variety and excellence of agricultural implements* is so great that the prudent farmer in regard to that, as well as in every other branch of his art, must study economy. He should not incur an unnecessary expense in buying them, nor in purchasing more than are essentially requisite, and can be profitably used. This maxim ought to be more especially attended to by young improvers, who are often tempted, under the specious idea of diminishing labor, and saving expense, to buy a superfluous quantity of implements, which they afterwards find are of little use. (*Coventry's Disc.* p. 47.) It is remarked by an intelligent author on matters of husbandry, that a great diversity of implements, as they are more rarely used, prove in general a source of vexation and disappointment, rather than of satisfaction to the farmer.

4487. *The different implements required by the farmer* are: those of tillage, for drilling or sowing corn; for reaping corn; for harvesting corn; for threshing and cleaning corn; for mowing and harvesting hay; for conveyance; for draining; for harnessing stock; for rolling land; for the dairy; and, for miscellaneous purposes.

4488. *In purchasing implements*, the following rules are to be observed: they should be simple in their construction, both that their uses may be more easily understood, and that any common workman may be able to repair them, when they get out of order; the materials should be of a durable nature, that the labor may be less liable to interruption from their accidental failure; their form should be firm and compact, that they may not be injured by jolts and shaking; and that they may be more safely worked by country laborers, who are but little accustomed to the use of delicate tools. In the larger machines, symmetry, and lightness of shape, ought to be particularly attended to: for a heavy carriage, like a great horse, is worn out by its own weight, nearly as much as by what he carries. The wood should be cut up and placed in a position the best calcu-

lated to resist pressure ; and mortises, so likely to weaken the wood, should, as much as possible, be avoided ; at the same time, implements should be made as light as is consistent with the strength that is necessary. Their price should be such, that farmers in moderate circumstances can afford to buy them ; yet for the sake of a low price, the judicious farmer will not purchase articles, either of a flimsy fabric, or a faulty form ; and implements ought to be suited to the nature of the country, whether hilly or level, and more especially to the quality of the soil ; for those which are calculated for light land, will not answer equally well in soils that are heavy and adhesive. (*Code.*)

4489. *In the choice of seed corn* regard must be had to procure it from a suitable soil and climate, and of a suitable variety. A change from one soil to another of a different quality, is generally found advantageous ; but this is not always the case as to climate. Thus some of the varieties of oats, as the Angus oat, which answers well in most parts of Scotland, is found not to fill in the ear, but to shrivel up after blossoming in the south of England. In like manner, the woolley-chafed white wheats of Essex and Kent, rot in the ear, when grown in the moist climate of Lancashire. In settling on a farm in a country with which the farmer is little acquainted, he will often find it adviseable to select the best seed he can find in the neighborhood, and probably to resift it and free it from the seeds of weeds and imperfect grains. Particular care is requisite in selecting the seed of the bean and pea, as no crop depends more on the variety being suited to the soil and climate. Thus, on hot gravelly soils in the south, the late grey pea would produce little haulm and no pulse ; but the early varieties, or the pearl pea, will produce a fair proportion of both.

4490. The only *small seeds* the farmer has to sow on a large scale, are the different varieties of turnip, and probably the mangoldwurzel and carrot. No expense or trouble should be spared to procure the best turnip seed ; as if that is either mixed by impregnation with other varieties of the Brassica tribe, or has been raised from a degenerate small bulbed parentage, the progeny will never come to any size. The same may be said of carrot or mangold seed, raised from small misshapen roots. Even rape seed should be raised from the strongest and largest bulbed plants, as these always produce a stronger progeny.

4491. Of the *plants* which the farmer has to choose for stock, the chief is the potatoe, and every one knows that no circumstances in the soil, climate, or culture will compensate for planting a bad sort. The potatoe requires a climate rather humid as otherwise, and rather moderate and equable in temperature than hot : hence the best crops are found in Lancashire, Dumfriesshire, and Ayrshire in Britain, and in Ireland where the climate is every where moist. Excellently-flavored potatoes are also grown on mossy lands in most parts of the country. The prudent farmer will be particularly careful in choosing this description of plant stock, and also in changing it frequently so as to ensure prolificacy and flavor.

### SECT. III. *Of the Choice of Servants.*

4492. *On the moral and professional character of his servants* much of the comfort of the farmer depends, and every one who has farmed near large towns, and at a distance from them, knows how great the difference is in every description of laborers. The servants required in farmeries are the bailiff or head ploughman, common ploughmen, shepherds, laborers of all work, herdsmen, and women. Sometimes apprentices and pupils are taken ; but their labor is not often to be much depended on.

4493. *A bailiff* is required only in the largest description of farms, occupied by a professional farmer ; and is not often required to act as market man. In general young men are preferred, who look forward to higher situations, as gentlemen's bailiffs or land stewards. Most farmers require only a head ploughman, who works the best pair of horses and takes the lead of, and sets the example to, the other ploughmen in every description of work.

4494. *Ploughmen* should, if possible, be yearly servants, unless they are married and have families. Weekly or occasional ploughmen are found comparatively unsteady ; they are continually wandering from one master to another, and are very precarious supports of a tillage farm : for they may quit their service at the most inconvenient time, unless bribed by higher wages ; and the farmer may thus loose the benefit of the finest part of the season. Where day laborers, however, are married, they are more to be depended upon, than unmarried domestic servants, more especially when the laborer has a family, which ties him down to regular industry.

4495. *The mode of hiring servants* at what are called public statutes, so general in many parts of England, is justly reprobated, as having a tendency to vitiate their minds, enabling them to get places without reference to character, exposing good servants to be corrupted by the bad, promoting dissipation, and causing a cessation of country business for some days, and an awkwardness in it for some time afterwards. When hiring servants, it would be extremely important, if possible, to get rid of any injurious perquisites, which

are often prejudicial to the interests of the master, without being of any advantage to the servant. For instance, in Yorkshire and in other districts, it is a custom to give farm servants liquor, both morning and evening, whatever is the nature and urgency of the work. Nothing can be more absurd than permitting a ploughman to stop for half an hour in a winter day to drink ale, while his horses are neglected and shivering with cold.

4496. *The following plan of maintaining the hinds or ploughmen in the best cultivated districts in Scotland*, is found by experience to be greatly superior to any other mode hitherto adopted.

4497. *Proper houses* are built for the farm servants, contiguous to every farmstead. This gives them an opportunity of settling in life, and greatly tends to promote their future welfare. Thus also the farmer has his people at all times within reach, for carrying on his business.

4498. *The farm servants*, when married, receive the greater part of their wages in the produce of the soil, which gives them an interest in the prosperity of the concern in which they are employed, and in a manner obliges them to eat and drink comfortably; while young men often starve themselves in order to save money for drinking or clothes; in either of which cases they are deficient in the requisite animal strength. At least, under this mode of payment, they are certain of being supplied with the necessaries of life, and a rise of prices does not affect them; whereas, when their wages are paid in money, they are exposed to many temptations of spending it, which their circumstances can ill afford; and during a rise of prices they are sometimes reduced to considerable difficulties. From the adoption of an opposite system, habits of sobriety and economy, so conspicuous among the farm servants of Scotland, and the advantages of which cannot be too highly appreciated, have arisen and still prevail in these districts.

4499. A most important branch of this system is, that *almost every married man has a cow*, of a moderate size, kept for him by the farmer all the year round. This is a boon of great utility to his family. The prospect of enjoying this advantage has an excellent effect upon the morals of young unmarried servants, who, in general, make it a point to lay up as much of their yearly wages as will enable them to purchase a cow and furniture for a house when they enter into the married state. These savings, under different circumstances, would most probably have been spent in dissipation.

4500. They have *also several other perquisites*, as a piece of ground for potatoes and flax, (about one-eighth part of an acre for each); liberty to keep a pig, half a dozen hens, and bees; their fuel is carried home to them; they receive a small allowance in money per journey, when sent from home with corn, or for coals or lime; and during the harvest, they are maintained by the farmer, that they may be always at hand.

4501. *There are nowhere to be met with, more active, respectable, and conscientious servants, than those who are kept according to this system.* There is hardly an instance of their soliciting relief from the public. They rear numerous families, who are trained to industry, and knowledge in the operations of agriculture, and whose assistance in weeding the crops, &c. is of considerable service to the farmer. They become attached to the farm, take an interest in its prosperity, and seldom think of removing from it. Under this system, every great farm is a species of little colony, of which the farmer is the resident governor. Nor, on the whole, can there be a more gratifying spectacle, than to see a large estate, under the direction of an intelligent landlord, or of an agent competent to the task of managing it to advantage; where the farms are of a proper size; where they are occupied by industrious and skilful tenants, anxious to promote, in consequence of the leases they enjoy, the improvement of the land in their possession; and where the cultivation is carried on by a number of married servants, enjoying a fair competence, and rearing large families, sufficient, not only to replace themselves, but also from their surplus population, to supply the demand, and even the waste, of the other industrious classes of the community. Such a system, there is reason to believe, is brought to a higher degree of perfection, and carried to a greater extent, in the more improved districts of Scotland, than perhaps any other country in Europe. (*Code, &c.*)

4502. *A shepherd* is of course only requisite on sheep farms; and no description of farm servant is required to be so steady and attentive. At the lambing season much of the farmer's property is in his hands, and depends on his unwearied exertions early and late. Such servants should be well paid and comfortably treated.

4503. *The laborers* required on a farm are few; in general, one for field operations, as hedge and ditch work, roads, the garden, cleaning out furrows, &c.; and another for attending to the cattle, pigs, and straw-yard, killing sheep and pigs when required, &c. will be sufficient. Both will assist in harvest, hay-time, threshing, filling dung, &c. These men are much better servants when married and hired by the year, than when accidental day laborers.

4504. *The female servants* required in farmery are casual, as hay-makers, turnip hoers, &c.; or yearly, as house, dairy, and poultry maids: Much depends on the steady

ness of the first class, and it is in general better to select them from the families of the married servants, by which means their conduct and conversation is observable by their parents and relations. A skilful dairymaid is a most valuable servant, and it is well when the cattle-keeper is her husband; both may live in the farmer's house (provided they have no children), and the man may act as groom to the master's horse and chaise, and assist in brewing, butchery, &c. In the cheese districts, men often milk the cows and manage the whole process of the dairy; but females are surely much better calculated for a business of so domestic a nature, and where so much depends on cleanliness.

4505. *Farmers' apprentices* are not common, but parish boys are so disposed of in some parts of the west of England, and might be so generally. They are said to make the best and steadiest servants; and indeed, the remaining in one situation, and under one good master for a fixed period, say not less than three years, must have a great tendency to fix the character and morals of youth in every line or condition of life.

4506. *Apprentices intended for farmers* are generally young men who have received a tolerable education beforehand, and have attained to manhood or nearly so. These pay a premium, and are regularly instructed in the operations of farming. We have already alluded to the example of Walker, who considers such apprentices, notwithstanding the care required to instruct them, rather useful than otherwise. (*Husb. of Scot.* vol. ii. p. 106.)

4507. *To train ploughmen to habits of activity and diligence* is of great importance. In some districts they are proverbial for the slowness of their step, which they teach their horses, whereas these animals, if accustomed to it, would move with as much ease to themselves, in a quick, as in a slow pace. Hence their ploughs seldom go above two miles in an hour, and sometimes even less; whereas where the soil is light and sandy, they might go at the rate of three miles and a half. Farmers are greater sufferers than they imagine, by this habitual indolence of their workmen, which extends from the plough to all their other employments, for it makes a very important difference in the expense of labor. Where the land however is stiff, and deep ploughing is necessary, the operation ought not to be too much hurried. (*Code.*)

---

#### CHAP. IV.

##### *Of the general Management of a Farm.*

4508. The importance of an *orderly systematic mode of managing* every concern is sufficiently obvious. The points which chiefly demand a farmer's attention are the accounts of money transactions, the management of servants, and the regulation of labors.

##### SECT. I. *Of keeping Accounts.*

4509. It is a maxim of the Dutch, that "*no one is ever ruined who keeps good accounts,*" which are said, in *The Code of Agriculture*, to be not so common among farmers as they ought to be; persons employed in other professions being generally much more attentive and correct. Among gentlemen farmers there is often a systematic regularity in all their proceedings, and their pages of debtor and creditor, of expense and profit are as strictly kept as those of any banking-house in the metropolis. But with the generality of farmers, the case is widely different. It rarely happens, that books are kept by them in a minute and regular manner; and the accounts of a farmer, occupying even a large estate, and consequently employing a great capital, are seldom deemed of sufficient importance to merit a share of attention, equal to that bestowed by a tradesman, on a concern of not one-twentieth part of the value. There is certainly some difficulty in keeping accurate accounts respecting the profit and loss of so uncertain and complicated a business as the one carried on by the farmer, which depends so much on the weather, the state of the markets, and other circumstances not under his control; but the great bulk of farming transactions is settled at the moment, that is to say, the article is delivered, and the money instantly paid, so that little more is necessary than to record these properly. In regard to the expenses laid out on the farm, an accurate account of them is perfectly practicable, and ought to be regularly attended to by every prudent and industrious occupier. By examining these, a farmer is enabled to ascertain the nature and the extent of the expense he has incurred, in the various operations of agriculture; and to discover what particular measures, or what general system, contributes to profit, or occasions loss. The principle of economy may thus be introduced into the management of a farm, and the lessening of expense effected, which is every day becoming of greater importance, as bearing a higher proportion to the produce of the farm.

4510. *To record pecuniary transactions* is not the only object to be attended to in the accounts of a farmer. It is necessary to have an annual account of the live stock, and







4520.

Stock Account.

Increase and Decrease of Live Stock.							What Part of the Farm occupied by the Cattle.				
Description.	Increase by		Decrease by		Total.	Date when sent in.	When taken out.	Number and Description of Cattle.	No. of the Field.	Nature of the Crop in the Field.	
	No.	Purchase.	Birth.	Death.							Sale.
Sheep.	Rams										
	Ewes	Spaniard									
	Wethers										
	R. Lambs	Spaniards									
	E. Lambs	Ditto									
Cattle.	Bulls										
	Cows										
	Oxen										
	Heifers										
	B. Calves										
	C. Calves										
Pigs.	Boars										
	Sows										
	Barrows										
	Pigs										
Horses.	Horses										
	Mares										
	Colts										
Poultry and Eggs.	Turkies										
	Fouls										
	Fowls										
	Chickens										
	Geese										
	Goslings										
	Ducks										
	Ducklings										
	Pigeons										
Eggs											

4521. *The account books for a common farmer*, may be a cash-book for all receipts and payments, specifying each; a ledger for accounts with dealers and tradesmen; and a stock book for taking an inventory and valuation of stock, crop, manures, tillages, (and every thing that a tenant could dispose of or be paid for on quitting his farm) once a year. Farming may be carried on with the greatest accuracy and safety, as to money matters, by means of the above books, and a few pocket memorandum books for laborers' time, jobs, &c. With the exception of a time-book, such as we have before described (3140.), we should never require more, even from a proprietor's bailiff; to many of whom the nine forms just given (4512.) would only puzzle; — to some we have known them lead to the greatest errors and confusion. No form of books, or mode of procedure, will enable a farmer to know whether he is losing or gaining but that of taking stock. Valuing produce consumed, and crediting the farm with it, is in practice nonsense; and the same may be said of various items in most of these nine forms. An approximation to the profits yielded by particular crops or modes of management, may always be made by the farmer or bailiff from recollection. There can never be a field on the farm, which he cannot at the time of reaping the crop, tell how often it has been ploughed; when manured, what the seed was worth, &c.; and from these and the other usual data, he can easily make out a Dr. and Cr. account, sufficient for all practical purposes.

SECT. II. Management of Servants.

4522. In order that servants may be able and willing to do their work, it is necessary that they be well fed, comfortably lodged, and decently clothed. The last requisite may be



left to their own judgment, allowing an adequate sum or wages for that purpose: but the feeding and clothing of farm servants, and especially of single men, requires to be seen to by the master. Without this attention on the part of the latter, the sum allowed for these purposes will either be in part hoarded up, or idly spent, in either case lessening the physical strength, and often injuring the moral faculties of the man.

4523. *In former times*, the servants lived at the same table with their masters, and that is still the practice in those districts where the farms are small. On moderate-sized, and on large farms, they are usually sent to a separate table; but of late a custom has been introduced of putting them on board-wages. This is a most pernicious practice; which often leads them to the ale-house, corrupts their morals, and injures their health. It is a better plan, with a view of lessening trouble, to board them with the bailiff; but it is still more desirable for the farmer, to have them under his own eye, that he may attend to their moral conduct. He will find much more useful assistance, from the decent and the orderly, than from the idle and the profligate.

4524. *The best mode of managing yearly married servants*, whether ploughmen or laborers, we conceive to be that already referred to (4496.) as practised in Northumberland, and other northern counties. Marshal (*Review of Bailey's Northumberland*) calls it a remnant of feudal times; but certainly, if it is so, it appears one of those remains which should be carefully preserved. We may challenge the empire to produce servants and farm operations equal to those where this system is adopted. The great excellence of the system consists on its being founded in the comfort of the servant.

4525. *The permanent laborers* on a farm ought to be treated in the same manner as the ploughmen; and indeed it is much to be wished, for the sake both of humanity and morality, that all married laborers, who live in the country, should have gardens attached to their cottages, if not a cow kept, and a pig, and fowls, in the manner of the Scottish ploughmen. Some valuable observations on this subject will be found in *The Husbandry of Scotland*, and *The Code of Agriculture*.

4526. *Temporary laborers*, or such as are engaged for hay-making, reaping, turnip-hoeing, &c. are for the most part beyond the control of the farmer as to their living and lodging. It is a good practice, however, where hay-making and reaping is performed by the day, to feed the operators, and to lodge such of them as have not homes in the neighborhood, on the premises; providing them with a dry loft, and warm blankets. Piece or job-work, however, is now becoming so very general, in all farm operations performed by occasional laborers, that attention to these particulars becomes unnecessary, and the farmer's chief business is to see that the work be properly done.

4527. *A day's work of a country laborer* is ten hours during the spring, summer, and autumn quarters. Farmers, however, are not at all uniform in their hours of working during these periods. Some begin at five o'clock, rest three hours at mid-day, during the more violent heat of the sun, and fill up their day's work, by beginning again at one o'clock, and ending at six in the evening. Others begin at six, and end at six, allowing half an hour at breakfast, and an hour at dinner. But although these be the ordinary hours, both for servants and laborers, during the more busy seasons of the year, yet neither of them will scruple to work either sooner or later, when occasion requires. In regard to the winter months, the hours of labor are from the dawn of morning, as long as it is light, with the allowance of about half an hour at mid-day for dinner.

4528. *That the rate of labor* must in a great measure depend upon the price of grain, is a general principle. In England, the value of a peck of wheat, and in Scotland, of a peck of oatmeal, (being the principal articles of subsistence of the lower orders of the people in the two countries,) were long accounted an equivalent to the daily pay of a laborer. In both countries, however, the price of potatoes has, of late years, had a considerable influence in the rate of labor; and in England, the effects of the poor laws have tended to keep down that rate below the increased price of provisions, and thus have deranged the natural progress of things. It has been ascertained, that a man, his wife, and from two to three children, if wheat is their habitual food, will require ten gallons weekly. When they live on bread, hard working people ought to have the best kind, as that will furnish the most nutrition. How then could a laborer and his family exist, upon wages of from 6s. to 9s. per week, when wheat is from 8s. to 10s, or 12s. per bushel? The difference is compensated by the poor-rates, a most exceptionable mode of making up the deficiency; for labor would otherwise have found its own level, and the laborer would have obtained the price of a bushel and a half of wheat weekly.

4529. *In Scotland*, the rate of labor has increased beyond the price of provisions. Prior to 1792, the average price of a peck of oatmeal was 1s. 1d. and the average price of a day's labor in summer, 1s. 1½d. which nearly corresponded with the principle above stated: but the average price of a peck of oatmeal, in 1810, was 1s. 3¾d. whilst the average price of a day's labor was 1s. 10½d. which shews, in a most satisfactory manner, the very great improvement that has taken place, in the lot of the laboring classes, in that part of the united kingdom. (*Gen. Rep.* vol. iii. p. 262.)

4530. *The practice of giving laborers grain, &c. at a cheap rate*, was adopted by George III. who carried on farming operations to a considerable extent, allowing his laborers flour at a fixed price, whatever wheat might sell for. This benevolent system has been practised by several gentlemen farmers, some of whom have allowed bread, and others a daily quantity of milk, at moderate prices. The same system is general in several of the western counties, as in Dorset, Devon, and Cornwall, where the laborers have a standing supply of bread-corn; of wheat at 6s. and of barley at 3s. per bushel.

4531. *In the wages of labor, as well as in every thing else, moderation is desirable.* It is remarked, that high wages have a tendency to throw laborers out of employment, as farmers in general, and even small proprietors, are unable to give such wages; hence they are obliged to carry on their work with fewer hands, or to postpone improvements, which otherwise they would have undertaken. Nor is that all. The laborers themselves suffer by it, and so does the public. In the fens of Lincolnshire, wages have risen in harvest time, from 3s. 6d. to 7s. nay to 10s. 6d. per day, every day's hiring taking place at a certain spot, where masters, whose work is in haste, outbid each other, and thus raise the wages to that exorbitant height. The consequence was, that the laborers got drunk, would not work above four days out of the six, dissipated their money, hurt their constitutions, contracted indolent and vicious habits, and their labor was lost to the community, for at least one-third part of the time, at a most important crisis. (*Code, &c.*)

4532. *Most descriptions of country labor, performed without the aid of horses, may be let by the job.* Farey, in his excellent *Report of Derbyshire*, informs us, that besides all ordinary labor, the late John Billingsley, of Ashwick Grove, in Somersetshire, let his ploughing, harrowing, rolling, sowing, turning of corn when cut, hay-making, &c. by the acre, and from which he found great advantages, even where his own oxen and horses were used, by the takers of the work. Whether we regard dispatch, economy, perfection of rural works, or the bettering of the condition of the laborers therein, nothing will contribute so much to all these, as a general system of letting works at fair and truly apportioned prices, according to the degree of labor and skill required, in each kind of work. Few persons have doubted that dispatch and economy are attainable by this method, but those who have indolently or improperly gone about the letting of their labor, have uniformly complained of its being slovenly done, and of the proneness of the men to cheat, when so employed. These last are to be expected in all modes of employment, and can only be counteracted, or made to disappear, by competent knowledge and due vigilance in the employer, or his agents and foremen, who ought to study and understand the time and degree of exertion and skill, as well as the best methods, in all their minutiae of performing all the various works they have to let. At first sight, these might seem to be very difficult and unattainable qualifications in farmers' bailiffs, or foremen, but it is nevertheless certain, that a proper system and perseverance will soon overcome these difficulties. One of the first requisites is, the keeping of accurate and methodical day-accounts of all men employed; and, on the measuring up and calculating of every job of work, to register how much has been earned per day, and never to attempt abatement of the amount, should this even greatly exceed the ordinary day's pay of the country; but let this experience gained, operate in fixing the price of the next job of the same work, in order to lessen the earnings by degrees, of fully competent and industrious men, to  $1\frac{3}{4}$  to  $2\frac{1}{4}$  times the ordinary wages when working by the day.

4533. *Select the men into small gangs*, according to their abilities and industry, and always set the best gang about any new kind of work, or one whose prices want regulating, and encourage these by liberal prices at first, and gradually lower them, and by degrees introduce the other gangs to work with or near to them at the same kind of work. On the discovery of any material slight of, or deceptions in the work, at the time of measuring it, more than their proportionate values should be deducted for them, and a separate job made to one of the best gangs of men, for completing or altering it: by which means shame is made to operate, with loss of earnings, in favor of greater skill, attention, and honesty in future. When the necessity occurs of employing even the best men by the day, let the periods be as short as possible, and the prices considerably below job earnings, and contrive, by the offer of a desirable job to follow, to make it their interest and wish to dispatch the work that is necessary to be done by the day, in order to get again to piece-work. The men being thus induced to study and contrive the readiest and best methods of performing every part of their labor, and of expending their time, the work will unquestionably be better done than by the thoughtless drones who usually work by the day. And that these are the true methods of bettering the condition of the laborers, Malthus has ably shewn in theory, and all those who have adopted and persevered in them, have seen the same in practice. (*Farey's Derbyshire*, vol. iii. 192.)

### SECT. III. *Of the Arrangement of Farm Labor.*

4534. *The importance of order and system* we have already insisted on (3127.), and the subject can hardly be too often repeated. To conduct an extensive farm well, is not a matter of trivial moment, or to the management of which every one is competent. Much may be effected by capital, skill, and industry; but even these will not always

ensure success, without judicious arrangement. With it, a farm furnishes an uninterrupted succession of useful labor during all the seasons of the year; and the most is made that circumstances will admit of, by regularly employing the laboring persons and cattle, at such works as are likely to be the most profitable. Under such a system, it is hardly to be credited how little time is lost, either of the men or horses, in the course of a whole year. This is a great object; for each horse may be estimated at three shillings per day, and each man at two shillings. Every day, therefore, in which a man and horse are unemployed, occasions the loss of at least five shillings to the husbandman.

4535. *As the foundation of a proper arrangement*, it is necessary to have a plan of the farm, or at least a list of the fields or parcels of land into which it is divided, describing their productive extent, the quality of the soil, the preceding crops, the cultivation given to each, and the species and quantity of manure they have severally received. The future treatment of each field, for a succession of years, may then be resolved on with more probability of success. With the assistance of such a statement, every autumn an arrangement of crops for the ensuing year ought to be made out; classing the fields or pieces of land, according to the purposes for which they are respectively intended. The number of acres allotted for arable land, meadow, or pasture, will thus be ascertained. It will not then be difficult to anticipate what number of horses and laborers will be required during the season for the fields in culture, nor the live stock that will be necessary for the pasture land. The works of summer and harvest will likewise be foreseen, and proper hands engaged in due time to perform them.

4536. *A farmer should have constantly in view a judicious rotation of crops*, according to the nature and quality of his soil, and should arrange the quantity and succession of labor accordingly. Team labor, when frost and bad weather do not intervene, should be arranged for some months; and hand labor, for some weeks, according to the season of the year. "A general memorandum list of business to be done," may therefore be useful, that nothing may escape the memory, and that the most requisite work may be brought forward first, if suitable to the state of the weather. In this way, the labor will go on regularly, and without confusion, while by a proper attention, either a distribution of labor, or an occasional consolidation of it, may be applied to every part of the farm.

4537. *As general rules*, connected with the arrangement, and the successful management of a farm, the following are particularly to be recommended.

4538. *The farmer ought to rise early*, and see that others do so. In the winter season, breakfast should be taken by candle light, for by this means an hour is gained, which many farmers indolently lose; though six hours in a week are nearly equal to the working part of a winter day. This is a material object, where a number of servants are employed. It is also particularly necessary for farmers to insist on the punctual performance of their orders.

4539. *The whole farm should be regularly inspected*, and not only every field examined, but every beast seen, at least once a day, either by the occupier, or by some intelligent servant.

4540. In a considerable farm, it is of the utmost consequence to have *servants specially appropriated for each of the most important departments of labor*; for there is often a great loss of time, where persons are frequently changing their employments. Besides, where the division of labor is introduced, work is executed not only more expeditiously, but also much better, in consequence of the same hands being constantly employed in one particular department. For that purpose, the ploughmen ought never to be employed in manual labor, but regularly kept at work with their horses, when the weather will admit of it.

4541. To arrange the *operation of ploughing*, according to the soils cultivated, is an object of essential importance. On many farms there are fields, which are soon rendered unfit to be ploughed, either by much rain, or by severe drought. In such cases, the prudent farmer, before the wet season commences, should plough such land as is in the greatest danger of being injured by too much wet; and before the dry period of the year sets in, he should till such land as is in the greatest danger of being rendered unfit for ploughing by too much drought. The season between seed time and winter may be well occupied in ploughing soils intended to be sown with beans, oats, barley, and other spring crops, by means of the grubber (2533.). On farms where these rules are attended to, there is always some land in a proper condition to be ploughed; and there is never any necessity, either for delaying the work, or performing it improperly.

4542. Every means should be thought of to *diminish labor, or to increase its power*. For instance, by proper arrangement, five horses may do as much labor as six perform, according to the usual mode of employing them. One horse may be employed in carting turnips during winter, or in other necessary farm work at other seasons, without the necessity of reducing the number of ploughs. When driving dung from the farm-yard,

three carts may be used, one always filling in the yard, another going to the field, and a third returning; the leading horse of the empty cart ought then to be unyoked, and put to the full one. In the same manner, while one pair of horses are preparing the land for sowing turnips, the other three horses may be employed in carrying the dung to the land, either with two or three carts, as the situation of the ground may happen to require. By extending the same management to other farm operations, a considerable saving of labor may be effected.

4543. *Previously to engaging in a work*, whether of ordinary practice, or of intended improvement, the best consideration of which the farmer is capable ought to be given to it, till he is satisfied that it is advisable for him to attempt it. When begun, he ought to proceed in it with much attention and perseverance, until he has given it a fair trial. It is a main object, in carrying on improvements, not to attempt too much at once; and never to begin a work without a probability of being able to finish it in due season.

4544. *By the adoption of these rules, every farmer will be master of his time*, so that every thing required to be done, will be performed at the proper moment; and not delayed till the season and opportunity have been lost. The impediments arising from bad weather, sick servants, or the occasional and necessary absence of the master, will, in that case, be of little consequence, nor embarrass the operations to be carried on; and the occupier will not be prevented from attending to even the smallest concerns connected with his business, on the aggregate of which his prosperity depends.

#### SECT. IV. *Of domestic Management and personal Expenses.*

4545. *On domestic affairs*, a hint may suffice. Young farmers beginning house-keeping, like most others in similar circumstances, are apt to sink too great a proportion of their capital in furniture, and furnishing riding-horses, carriages, &c.; and sometimes to live up to, or even beyond, their income. We do not mean that farmers should not live as well as other men of the same property; but merely that all beginners should live within their income. Even in the marketing expenses care is requisite; and the prudent farmer will do well, every penny or sixpence he lays out, to reckon up in his mind what that sum per day would amount to in a year. The amount will often astonish him, and lead to economy, and where practicable, retrenchment. Saving, as Franklin has inculcated, is the only certain way of accumulating money.

4546. In regard to *housekeeping*, it is observed in *The Code of Agriculture*, that the safest plan is, not to suffer it to exceed a certain sum for bought articles weekly. An annual sum should be allotted for clothing, and the personal expenses of the farmer, his wife, and children, which ought not to be exceeded. The whole allotted expense should be considerably within the probable receipts; and if possible one-eighth of the income annually received, should be laid up for contingencies, or expended in extra improvements on the farm.

---

## BOOK VI.

### OF THE CULTURE OF FARM LANDS.

4547. *The business of farming* consists of the culture of vegetables, and the treatment or culture of animals; in practice these are generally carried on together, but may be more conveniently treated of apart. In this Book, therefore, we confine ourselves to the culture of vegetables, and shall consider in succession the general processes of culture; the culture of corn and pulse; of roots and leaves; of herbage plants; of grasses; and of manufactory plants.

---

#### CHAP. I.

##### *Of the general Processes common to Farm Lands.*

4548. Among *general processes*, those which merit particular notice in this place, are the rotation of crops, the working of fallows, and the management of manures. The theory of these processes has been already given in treating of soils and manures (PART II. BOOK III.); and it therefore only remains to detail their application to practice under different circumstances.

SECT. I. *Of the Rotations of Crops suitable to different Descriptions of Soils.*

4549. *The proper distribution of crops, and a plan for their succession, is one of the first subjects to which a farmer newly entered on a farm requires to direct his attention.* The kind of crops to be raised are determined in a great measure by the climate, soil, and demand; and the quantity of each, by the value, demand, and the adjustment of farm labor.

4550. *In the adjustment of farm labor, the great art is to divide it as equally as possible throughout the year.* Thus it would not answer in any situation to sow exclusively autumn crops, as wheat or rye; nor only spring corns, as oats or barley; for by so doing all the labor of seed-time would come on at once, and the same of harvest work, while the rest of the year there would be little to do on the farm. But by sowing a portion of each of these and other crops, the labor both of seed-time and harvest is divided and rendered easier, and more likely to be done well and in season. But this point is so obvious as not to require elucidation.

4551. *The succession or rotation of crops, is a point on which the profits of the farmer depend more than on any other.* It is remarked by Arthur Young, that the agricultural writers, previously to the middle of the eighteenth century, paid little or no attention to it. They recite, he says, courses good, bad, and execrable, in the same tone; as matters not open to praise or censure, and unconnected with any principles that could throw light on the arrangement of fields. The first writer who assigned due importance to the subject of rotations seems to have been the Rev. Adam Dickson, in his *Treatise on Agriculture*, published in Edinburgh, in 1777; and soon afterwards Lord Kaimes, in his *Gentleman Farmer*, illustrates the importance of the subject; both writers were probably led to it by observing the effects of the Norfolk husbandry, then beginning to be introduced to Berwickshire. But whatever may have been the little attention paid to this subject by former writers, the importance of the subject of rotations, and the rule founded on the principles already laid down, that culmiferous crops ripening their seeds should not be repeated without the intervention of pulse roots, herbage, or fallow, is now "recognised in the practice and writings of all judicious cultivators, more generally perhaps than any other." (*Edit. of Farmer's Mag.*)

4552. *The system of rotations is adopted for every soil, though no particular rotation can be given for any one soil which will answer in all cases, as something depends on climate, and something also on the kind of produce for which there is the greatest market demand.* But wherever the system of rotations is followed, and the several processes of labor which belong to it properly executed, land will rarely get into a foul and exhausted state; or, at least if foul and exhausted under a judicious rotation, "matters would be much worse were any other system followed."

4553. *The particular crops which enter into a system of rotation must obviously be such as are suited to the soil and climate, though as the valuable author so often quoted observes, "they will be somewhat varied by local circumstances; such as the proximity of towns and villages, where there is a greater demand for turnips, potatoes, hay, &c. than in thinly-peopled districts.* In general, beans and clover, with rye-grass, are interposed between corn crops on clayey soils; and turnips, potatoes, and clover and rye-grass, on dry loams and sands, or what are technically known by the name of turnip soils. A variety of other plants, such as pease, tares, cabbages, and carrots, occupy a part, though commonly but a small part, of that division of a farm which is allotted to green crops. This order of succession is called the system of *alternate husbandry*; and on rich soils, or such as have access to abundance of putrescent manure, it is certainly the most productive of all others, both in food for man and for the inferior animals. One half of a farm is, in this course, always under some of the different species of *cereal gramina*, and the other half under pulse, roots, cultivated herbage, or plain fallow.

4554. *But the greater part of the arable land of Britain cannot be maintained in a fertile state under this management; and sandy soils, even though highly manured, soon become too incohesive under a course of constant tillage.* It, therefore, becomes necessary to leave that division or *break* that carries cultivated herbage, to be pastured for two years or more, according to the degree of its consistency and fertility; and all the fields of a farm are treated thus in their turn, if they require it. This is called the system of *convertible husbandry*, a regular change being constantly going on from aration to pasturage, and *vice versa*.

4555. *Not to repeat the same kind of crop at too short intervals is another rule with regard to the succession of crops.* Whatever may be the cause, whether it is to be sought for in the nature of the soil, or of the plants themselves, experience clearly proves the advantages of introducing a diversity of species into every course of cropping. When land is pastured several years before it is brought again under the plough, there may be less need for adhering steadily to this rule; but the degeneracy of wheat and other corn crops recurring upon the same land every second year for a long period, has been very gene-

rally acknowledged. It is the same with what are called green crops; beans and pease, potatoes, turnips, and, in an especial manner, red clover, become all of them much less productive, and much more liable to disease, when they come into the course, upon the same land, every second, third, or fourth year. But what the interval ought to be has not yet been determined, and probably cannot (from the great number of years that experiments must be continued to give any certain result) be determined, until the component parts of soils, and particularly the sort of vegetable nourishment which each species of plant extracts from the soil, have been more fully investigated.

4556. *A change of the variety*, as well as of the species, and even of the plants of the same variety, is found to be attended with advantage; and in the latter case, or a change of seed, the species and variety being the same, the practice is almost universal. It is well known, that of two parcels of wheat, for instance, as much alike in quality as possible, the one, which had grown on a soil differing much from that on which it is to be sown, will yield a better produce than the other that grew in the same, or a similar soil and climate. The farmers of Scotland, accordingly, find that wheat from the south, even though it be not, as it usually is, better than their own, is a very advantageous change; and oats and other grain, brought from a clayey to a sandy soil, other things being equal, are more productive than such as have grown on sandy soil. (*Supp. Encyc. Brit. art. Agr. 144.*)

4557. *The following are examples of rotations suited to different soils*, as given in Brown's excellent *Treatise on Rural Affairs*. The basis of every rotation, he says, "we hold to be either a bare summer fallow, or a fallow on which drilled turnips are cultivated, and its conclusion to be with the crops taken in the year preceding a return of fallow or drilled turnips, when of course a new rotation commences.

4558. *Rotation for strong deep lands*. According to this rotation, wheat and drilled beans are the crops to be cultivated, though clover and rye-grass may be taken for one year in place of beans, should such a variety be viewed as more eligible. The rotation begins with summer fallow, because it is only on strong deep lands that it can be profitably practised; and it may go on for any length of time, or so long as the land can be kept clean, though it ought to stop the moment that the land gets into a contrary condition. A considerable quantity of manure is required to go on successfully; perhaps dung should be given to each bean crop; and if this crop is drilled, and attentively horse-hoed, the rotation may turn out to be one of the most profitable that can be exercised.

4559. *Rotation for loams and clays*. Where it may not be advisable to carry the first rotation into execution, a different one can be practised; according to which labor will be more divided, and the usual grains more generally cultivated; as, for instance,

- |                                   |                          |                                  |
|-----------------------------------|--------------------------|----------------------------------|
| 1. Fallow, with dung.             | 4. Barley.               | 7. Beans drilled and horse-hoed. |
| 2. Wheat.                         | 5. Clover and rye-grass. | 8. Wheat.                        |
| 3. Beans, drilled and horse-hoed. | 6. Oats or wheat.        |                                  |

This rotation is excellently calculated to insure an abundant return through the whole of it, provided dung is administered upon the clover stubble. Without this supply, the rotation would be crippled, and inferior crops of course produced in the concluding years.

4560. *Rotation for clays and loams of an inferior description*. This rotation is calculated for soils of an inferior description to those already treated of.

- |                       |                          |                                   |
|-----------------------|--------------------------|-----------------------------------|
| 1. Fallow, with dung. | 3. Clover and rye-grass. | 5. Beans, drilled and horse-hoed. |
| 2. Wheat.             | 4. Oats.                 | 6. Wheat.                         |

According to this rotation, the rules of good husbandry are studiously practised, while the sequence is obviously calculated to keep the land in good order, and in such a condition as to ensure crops of the greatest value. If manure is bestowed, either upon the clover-stubble, or before the beans are sown, the rotation is one of the best that can be devised for the soils mentioned.

4561. *Rotation for thin clays*. On thin clays, gentle husbandry is indispensably necessary, otherwise the soil may be exhausted, and the produce unequal to the expense of cultivation. Soils of this description will not improve much while under grass; but, unless an additional stock of manure can be procured, there is a necessity of refreshing them in that way, even though the produce should, in the mean time, be comparatively of small value. The following rotation is not an improper one.

- |                       |   |           |
|-----------------------|---|-----------|
| 1. Fallow, with dung. | 3. Grass pastured, but not too early eaten. | 5. Grass. |
| 2. Wheat.             | 4. Grass.                                   | 6. Oats.  |

This rotation may be shortened or lengthened, according to circumstances, but should never extend further in point of ploughing, than when dung can be given to the fallow-break. This is the keystone of the whole; and if it is neglected, the rotation is rendered useless.

4562. *Rotation for peat earth soils.* These are not friendly to wheat, unless aided by a quantity of calcareous matter. Taking them in a general point of view, it is not advisable to cultivate wheat, but a crop of oats may almost be depended upon, provided the previous management has been judiciously executed. If the subsoil of peat earth lands be retentive of moisture, the process ought to commence with a bare summer fallow; but if such are incumbent on free and open bottoms, a crop of turnips may be substituted for fallow; according to which method, the surface will get a body which naturally it did not possess. Grass, on such soils, must always occupy a great space of every rotation, because physical circumstances render regular cropping utterly impracticable.

- |                                  |  |  |
|----------------------------------|--|--|
| 1. Fallow, or turnips with dung. | 3. Clover, and a considerable quantity of perennial rye-grass. | circumstances permit the land to be broken up, when oats are to be repeated. |
| 2. Oats of an early variety.     | 4. Pasture for several years, till                             |  |

4563. *Rotation for light soils.* These are easily managed, though to procure a full return of the profit which they are capable of yielding, requires generally as much attention as is necessary in the management of those of a stronger description. Upon light soils, a bare summer fallow is seldom called for, as cleanliness may be preserved by growing turnips, and other leguminous articles. Grass also is of eminent advantage upon such soils, often yielding a greater profit than what is afforded by culmiferous crops.

- |                             |                          |
|-----------------------------|--------------------------|
| 1. Turnips.                 | 3. Clover and rye-grass. |
| 2. Spring wheat, or barley. | 4. Oats or wheat.        |

This is a fashionable rotation; but it may be doubted whether a continuance of it for any considerable period is advisable, because both turnips and clover are found to fall off when repeated so often as once in four years. Perhaps the rotation would be greatly improved were it extended to eight years, whilst the ground, by such an extension, would be kept fresh and constantly in good condition. As for instance, were seeds for pasture sown in the second year, the ground kept three years under grass, broke up for oats in the sixth year, drilled with beans and pease in the seventh, and sown with wheat in the eighth; the rotation would then be complete, because it included every branch of husbandry, and admitted a variety in management generally agreeable to the soil, and always favorable to the interest of cultivators. The rotation may also consist of six crops, were the land kept only one year in grass, though few situations admit of so much cropping, unless additional manure is within reach.

4564. *Rotation for sandy soils.* These, when properly manured, are well adapted to turnips, though it rarely happens that wheat can be cultivated on them with advantage, unless they are dressed with alluvial compost, marl, clay, or some such substances as will give a body or strength to them, which they do not naturally possess. Barley, oats, and rye, the latter especially, are, however, sure crops on sands, and in favorable seasons will return greater profit than can be obtained from wheat.

- |                                     |                 |
|-------------------------------------|-----------------|
| 1. Turnips, consumed on the ground. | 3. Grass.       |
| 2. Barley.                          | 4. Rye or oats. |

By keeping the land three years in grass, the rotation would be extended to six years, a measure highly advisable.

4565. *These examples* are sufficient to illustrate the subject of improved rotations; but as the best general schemes may be sometimes momentarily deviated from with advantage, the same able author adds, that "cross cropping, in some cases, may perhaps be justifiable in practice; as, for instance, we have seen wheat taken after oats with great success, when these oats had followed a clover crop on rich soil; but, after all, as a general measure, that mode of cropping cannot be recommended. We have heard of another rotation, which comes almost under the like predicament, though, as the test of experience has not yet been applied, a decisive opinion cannot be pronounced upon its merits. This rotation begins with a bare fallow, and is carried on with wheat, grass for one or more years, oats, and wheat, where it ends. Its supporters maintain that beans are an uncertain crop, and cultivated at great expense; and that in no other way will corn, in equal quantity and of equal value, be cultivated at so little expense, as according to the plan mentioned. That the expense of cultivation is much lessened, we acknowledge, because no more than seven ploughings are given through the whole rotation; but whether the crops will be of equal value, and whether the ground will be preserved in equally good condition, are points which remain to be ascertained by experience." (*Brown on Rural Affairs.*)

4566. *As a general guide to devising rotations on clay soils,* it may be observed, that winter or autumn sown crops are to be preferred to such as are put in in spring. Spring ploughing on such soils is a hazardous business, and not to be practised where it can possibly be avoided. Except in the case of drilled beans, there is not the slightest necessity for ploughing clays in the spring months; but as land intended to carry beans ought to be early ploughed, so that the benefit of frost may be obtained, and as the seed furrow is an ebb one, rarely exceeding four inches in deepness, the hazard of spring

ploughing for this article is not of much consequence. Ploughing with a view to clean soils of the description under consideration, has little effect, unless given in the summer months. This renders summer fallow indispensably necessary, and without this radical process, none of the heavy and wet soils can be suitably managed, or preserved in a good condition.

4567. *To adopt a judicious rotation of cropping for every soil*, requires a degree of judgment in the farmer, which can only be gathered from observation and experience. The old rotations were calculated to wear out the soil, and to render it unproductive. To take wheat, barley, and oats in succession, a practice very common thirty years ago, was sufficient to impoverish the best of land, while it put little into the pockets of the farmer; but the modern rotations, such as those which we have described, are founded on principles which ensure a full return from the soil, without lessening its value, or impoverishing its condition. Much depends, however, upon the manner in which the different processes are executed, for the best arranged rotation may be of no avail, if the processes belonging to it are imperfectly and unseasonably executed. (See 2158.)

#### SECT. II. *Of the working of Fallows.*

4568. *The practice of fallowing*, as we have seen in our historical view of Greek and Roman agriculture, has existed from the earliest ages; and the theory of its beneficial effects we have endeavored to explain. (2125.) The Romans with their agriculture introduced fallows in every part of Europe, and two crops, succeeded either a year's fallow, or by leaving the land to rest for two or more years, became the rotation on all soils and under all circumstances. This mode of cultivating arable land is still the most universal in Europe; its prevalence till very lately in Britain created a powerful aversion to naked fallows, by which a crop was lost every year they occurred, and called forth numerous attempts to shew that they were unnecessary, consequently an immense public loss. This anti-fallowing mania, as it has been called, was chiefly supported by Arthur Young, Nathaniel Kent, and others, members or correspondents of the Board of Agriculture: it was at its greatest height about the beginning of the present century, but has now spent its force, and after exhausting all the arguments on both sides, as an able author has observed, "the practice does not appear to give way, but rather to extend."

4569. *The expediency or in expediency of pulverising and cleaning the soil by a bare fallow*, is a question that can be determined only by experience, and not by argument. No reasons, however ingenious, for the omission of this practice, can bring conviction to the mind of a farmer, who, in spite of all his exertions, finds, at the end of six or eight years, that his land is full of weeds, sour and comparatively unproductive. Drilled and horse hoed green crops, though cultivated with advantage on almost every soil, are probably in general unprofitable as a substitute for fallow, and after a time altogether inefficient. It is not because turnips, cabbages, &c. will not grow in such soils, that a fallow is resorted to, but because, taking a course of years, the value of the successive crops is found to be so much greater, even though an unproductive year is interposed, as to induce a preference to fallowing. Horse-hoed crops, of beans in particular, postpone the recurrence of fallow, but in few situations can ever exclude it altogether. On the other hand, the instances that have been adduced, of a profitable succession of crops on soils of this description, without the intervention of a fallow, are so well authenticated, that it would be extremely rash to assert that it can in no case be dispensed with on clay soils. Instances of this kind are to be found in several parts of Young's *Annals of Agriculture*; and a very notable one, on Greg's farm of Coles, in Hertfordshire, is accurately detailed in the sixth volume of *The Communications to the Board of Agriculture*.

4570. *The principal causes of this extraordinary difference among men of great experience*, may probably be found in the quality of the soil, or in the nature of the climate, or in both. Nothing is more vague than the names by which soils are known in different districts. Greg's farm, in particular, though the soil is denominated "heavy arable land," and "very heavy land," is found so suitable to turnips, that a sixth part of it is always under that crop, and these are consumed on the ground by sheep; a system of management, which every farmer must know to be altogether impracticable on the wet tenacious clays of other districts. It may indeed be laid down as a criterion for determining the question, that wherever this management can be profitably adopted, fallow, as a regular branch of the course, must be not less absurd than it is injurious, both to the cultivator and to the public. It is probable, therefore, that, in debating this point, the opposite parties are not agreed about the quality of the soil; and in particular, about its property of absorbing and retaining moisture, so different in soils, that in common language have the same denomination.

4571. *Another cause of difference* must be found in the climate. It is well known, that a great deal more rain falls on the west than on the east coast of Britain; and that between the northern and southern counties there is at least a month or six weeks' difference in the maturation of the crops. Though the soil therefore be as nearly as possible similar in quality and surface, the period in which it is accessible to agricultural operations must vary accordingly. Thus, in the south-eastern counties of the island, where the crops may be all cut down, and almost all carried home by the end of August, much may be done in cleansing and pulverising the soil, during the months of September and October, while the farmers of the north are exclusively employed in harvest work, which is frequently not finished by the beginning of November.



In some districts in the south of England, wheat is rarely sown before December; whereas in the north, and still more in Scotland, if it cannot be got completed by the end of October, it must commonly be delayed till spring, or oats or barley be taken in place of wheat. It does not then seem of any utility to enter farther into this controversy, which every skillful cultivator must determine for himself. All the crops, and all the modes of management which have been purposed as a substitute for fallow, are well known to such men, and would unquestionably have been generally adopted long ago, if, upon a careful consideration of the advantages and disadvantages on both sides, a bare fallow was found to be unprofitable in a course of years. The reader who wishes to examine the question fully may consult, among many others, the following:—Young's *Annals of Agriculture*, and his writings generally; Hunter's *Georgical Essays*; Dickson's *Practical Agriculture*; Sir H. Davy's *Agricultural Chemistry*; *The Agricultural Chemistry of Chaptal*; Brown's *Treatise on Rural Affairs*; *The County Reports*; and *The General Report of Scotland*.

4572. *Fallows unnecessary on friable soils.* However necessary the periodical recurrence of fallow may be on retentive clays, its warmest advocates do not recommend it on turnip soils, or on any friable loams incumbent on a porous subsoil; nor is it in any case necessary every third year, according to the practice of some districts. On the best cultivated lands it seldom returns oftener than once in six or eight years, and in favorable situations for obtaining an extra supply of manure, it may be advantageously dispensed with for a still longer period. (*Suppl. to Encyc. Brit. art. Agr.*)

4573. *The operation of fallowing*, as commonly practised in England, is a very different and comparatively useless, or at least ineffectual operation, to what it ought to be. In most places the first furrow is not given till the spring, or even till the month of May or June; or, if it is given earlier, the second is not given till after midsummer, and on the third the wheat is sown. Land may rest under this system of management; but to clean it from weeds, or pulverise it, or give it the benefits of aeration and heat, is impossible. The farmer in some cases purposely delays ploughing his fallows for the sake of the scanty bite the couch and weeds afford to his sheep; and for the same reason having ploughed once, he delays the second ploughing. It is not to be wondered at, that under such a system the theoretical agriculturist should have taken a rooted aversion to what are thus erroneously termed fallows. The practice of the best farmers of the northern counties is very different, and that practice we shall here detail.

4574. *A proper fallow* invariably commences after harvest; the land intended to be fallowed getting one ploughing, which ought to be as deep as the soil will admit, even though a little of the till or subsoil is brought up. This both tends to deepen the cultivated, or manured soil, as the fresh accession of hitherto uncultivated earth becomes afterwards incorporated with the former manured soil, and greatly facilitates the separation of the roots of weeds during the ensuing fallow process, by detaching them completely from any connection with the fast subsoil. This autumnal ploughing, usually called the winter furrow, promotes the rotting of stubble and weeds: and if not accomplished towards the end of harvest, must be given in the winter months, or as early in the spring as possible. In giving this first ploughing, the old ridges should be gathered up, if practicable, as in that state they are kept dry during the winter months; but it is not uncommon to split them out or divide them, especially if the land had been previously highly gathered, so that each original ridge of land is divided into two half ridges. Sometimes, when the land is easily laid dry, the furrows of the old ridges are made the crowns of the new ones, or the land is ploughed in the way technically called *crown-and-furrow*. In other instances, two ridges are ploughed together, by what is called *casting*, which has been already described. After the field is ploughed, all the inter-furrows, and those of the headlands, are carefully opened up by the plough, and are afterwards gone over effectually by a laborer with a spade, to remove all obstructions, and to open up the water furrows into the fence ditches, wherever that seems necessary, that all moisture may have a ready exit. In every place where water is expected to lodge, such as *dishes*, or hollow places in the field, cross or oblique furrows are drawn by the plough, and their intersections carefully opened into each other by the spade. Wherever it appears necessary, cross cuts are also made through the head ridges into the ditches with a spade, and every possible attention is exerted, that no water may stagnate in any part of the field.

4575. *As soon as the spring seed-time is over*, the fallow land is again ploughed end-long. If formerly split, it is now ridged up; if formerly laid up in gathered ridges, it is split or cloven down. It is then cross-ploughed; and after lying till sufficiently dry to admit the harrows, it is harrowed and rolled repeatedly, and every particle of the vivacious roots of weeds brought up to view, carefully gathered by hand into heaps, and either burnt on the field, or carted off to the compost midden. The fallow is then ridged up, which places it in a safe condition in the event of bad weather, and exposes a new surface to the harrows and roller; after which the weeds are again gathered by hand, but a previous harrowing is necessary. It is afterwards ploughed, harrowed, rolled, and gathered as often as may be necessary to reduce it into fine tilth and completely to eradicate all root-weeds. Between these successive operations, repeated crops of seedling weeds are brought into vegetation and destroyed. The larvæ likewise of various insects, together with an infinite variety of the seeds of weeds, are exposed to be devoured by birds, which are then the farmer's best friends, though often proscribed as his bitterest enemies.

4576. *The use of the harrow and roller in the fallow process*, has been condemned by some writers on husbandry, who allege, that frequent ploughing is all that is necessary to destroy root-weeds, by the baking or drying of the clods in the sun and wind; but experience has ascertained, that frequently turning over the ground, though absolutely necessary while the fallow process is going on, can never eradicate couch-grass or other root-weeds. In all clay soils, the ground turns up in lumps or clods, which the severest drought will not penetrate so sufficiently as to kill the included roots. When the land is again ploughed, these lumps are turned over and no more, and the action of the

plough serves in no degree to reduce them, or at least very imperceptibly. It may be added that these lumps likewise inclose innumerable seeds of weeds, which cannot vegetate unless brought under the influence of the sun and air near the surface. The diligent use, therefore, of the harrow and roller, followed by careful hand-picking, is indispensably necessary to the perfection of the fallow process. (*General Report of Scotland*, vol. iv. p. 419.)

4577. *When effectually reduced to fine tillth*, and thoroughly cleaned from roots and weeds, the fallow is ploughed end-long into gathered ridges or lands, usually fifteen or eighteen feet broad; which are set out in the manner already described, in treating of the striking of furrows or *feiring*. If the seed is to be drilled, the lands or ridges are made of such widths as may suit the construction of the particular drill-machine that is to be employed. After the land has been once gathered by a deep furrow, proportioned to the depth of the cultivated soil, the manure is laid on, and evenly spread over the surface, whether muck, lime, marl, or compost. A second gathering is now given by the plough; and this being generally the furrow upon which the seed is sown, great care is used to plough as equal as possible. After the seed is sown and the land thoroughly harrowed, all the inter-furrows, furrows of the headlands, and oblique or *gaw* furrows, are carefully opened up by the plough, and cleared out by the spade, as already mentioned, respecting the first or winter ploughing.

4578. *The expense of fallowing* must appear, from what has been said, to be very considerable, when land has been allowed to become stocked with weeds; but if it be kept under regular management, corn alternating with drilled pulse or green crops, the subsequent returns of fallow will not require nearly so much labor. In common cases, from four to six ploughings are generally given, with harrowing and rolling between, as may be found necessary; and, as we have already noticed, the *cultivator* may be employed to diminish this heavy expense. But it must be considered, that upon the manner in which the fallow operations are conducted, depend not only the ensuing wheat crop, but in a great measure all the crops of the rotation. (*Supp. to Encyc. Brit. art. Agr.* 128.)

### SECT. III. *Of the general Management of Manures.*

4579. *The manures of animal, vegetable, or mineral origin* have been already described, and their operation explained (2161.) But a very few of these substances can be obtained by farmers in general; whose standard resources are farm-yard dung and lime, and composts of these with earth. It is on the management of these that we propose to deliver the practice of the best British farmers.

#### SUBJECT. 1. *On the Management of Farm-yard Dung.*

4580. *The basis of farm-yard dung* is straw, to which is added in its progress through the farm-yard the excrementitious substances of live stock. From every ton of dry straw, about three tons of farm-yard dung may be obtained, if the after-management be properly conducted; and, as the weight of straw per acre runs from one ton to one and a half, about four tons of dung, on an average of the different crops, may be produced from the straw of every acre under corn. (*Husbandry of Scotland*, vol. ii.) Hence (it may be noticed) the great importance of cutting corn as low as possible; a few inches at the root of the stalk weighing more than double the same length at the ear.

4581. *The conversion of straw into farm-yard dung* in the farmery, is thus effected: The straw is served out to cattle and horses in the houses and fold-yards, either as provender or litter, and commonly for both purposes; turnips in winter, and green clover in summer are given to the stock both in the houses and yards; on this food the animals pass a great deal of urine, and afford the means of converting the straw into a richer manure than if it were eaten alone. All the dung from the houses, as they are cleaned out, is regularly spread over the yards, in which young cattle are left loose where litter is usually allowed in great abundance; or over the dunghill itself, if there be one at hand. This renders the quality of the whole mass more uniform; and the horse-dung, which is of a hot nature, promotes the decomposition of the woody fibres of the straw.

4582. *The preparation of the contents of the farm-yard for laying on the land*, is by turning it over; or, what is preferable, carting it out to a dunghill. The operation of carting out is usually performed during the frosts of winter: It is then taken to the field in which it is to be employed, and neatly built in dunghills of a square form, three or four feet high, and of such a length and breadth as circumstances may require. What is laid up in this manner early in winter, is commonly sufficiently prepared for turnips in June; but if it be not carried from the straw-yards till spring, it is necessary to turn it once or oftener, for the purpose of accelerating the decomposition of the strawey part of the mass. When dung is applied to fallows in July or August, preparatory to autumn sown wheat, a much less degree of putrefaction will suffice than for turnips: a clay soil, on which alone fallows should ever be resorted to, not requiring dung so much rotted as a finely pulverized turnip soil; and besides, as the wheat does not need all the benefit of the dung for some time, the woody fibre is gradually broken down in the course of the winter, and the nourishment of the plants continued till spring, or later, when its effects are most beneficial.

4583. *In the application of farm-yard dung to land under tillage*, particular attention is paid to the cleanness of the soil; and to use it at the time when, from the pulverisation of the ground, it may be most intimately mixed with it. The most common time of manuring with farm-yard dung is, therefore, either towards the conclusion of the fallowing operations, or immediately before the sowing of fallow crops. If no dung can be procured but what is made from the produce of the farm, it will seldom be possible to allow more than ten or twelve tons to every acre, when the land is managed under a regular course of white and green crops; and it is thought more advantageous to repeat this dose at short intervals, than to give a larger quantity at once, and at a more distant period in proportion. (*General Report of Scotland*, vol. ii. p. 517.) Farm-yard dung, it is well known, is greatly reduced in value by being exposed to the atmosphere in small heaps, previous to being spread, and still more after being spread. Its rich juices are exhale by the sun, or washed away by the rains, and the residuum is comparatively worthless. This is in an especial manner the case with long fresh dung, the far greater part of which consists of wet straw in an entire state. All careful farmers, accordingly, spread and cover in their dung with the plough, as soon as possible after it is brought on the land.

4584. *The use of fresh dung* is decidedly opposite to the practice of the best farmers of turnip soils; its inutility, or rather injurious effects, from its opening the soil too much, is a matter of experience with every one who cultivates drilled turnips on a large scale. As the whole farm-yard dung, on such land, is applied to the turnip crop, it must necessarily happen that it should be laid on in different stages of putrefaction; and what is made very late in spring, often after a very slight fermentation, or none at all. The experience of the effect of recent dung is accordingly very general, and the result, in almost every case, is, that the growth of the young plants is slow; that they remain long in a feeble and doubtful state; and that they seldom, in ordinary seasons, become a full crop, even though twice the quantity that is given of short muck has been allowed. On the other hand, when the manure is considerably decomposed, the effects are immediate, the plants rise vigorously, and soon put forth their rough leaf, after which, the beetle or fly does not seize on them; and in a few weeks, the leaves become so large, that the plants probably draw the greatest part of their nourishment from the atmosphere. Though it were true, therefore, that more nutritive matter were given out by a certain quantity of dung, applied in a recent state, and allowed to decompose gradually in the soil, than if applied after undergoing fermentation and putrefaction, the objection arising from the slowness of its operation, would, in many instances, be an insuperable one with farmers. But there seems reason to doubt whether fresh strawey manure would ferment much in the soil, after being spread out in so small a quantity as has been already mentioned; and also, whether, in the warm dry weather of summer, the shallow covering of earth given by the plough would not permit the gaseous matters to escape, to a much greater amount than if fermentation had been completed in a well built covered dunghill.

4585. *Another great objection to the use of fresh farm-yard dung* is, that the seeds and roots of those plants with which it commonly abounds, spring up luxuriantly on the land; and this evil nothing but a considerable degree of fermentation can obviate. The mass of materials consists of the straw of various crops, some of the grains of which, after all the care that can be taken, will adhere to the straw; of the dung of different animals voided, as is often the case with horses fed on oats, with the grain in an entire state; and of the roots, stems, and seeds of the weeds that had grown among the straw, clover, and hay, and such as had been brought to the houses and fold-yards with the turnips and other roots given to live stock.

4586. *The degree of decomposition to which farm-yard dung should arrive*, before it can be deemed a profitable manure, must depend on the texture of the soil, the nature of the plants, and the time of its application. In general, clayey soils, as more tenacious of moisture, and more benefited by being rendered incohesive and porous, may receive manure less decomposed than well pulverised turnip soils require. Some plants, too, seem to thrive better with fresh dung than others, potatoes in particular; but all the small-seeded plants, such as turnips, clover, carrots, &c. which are extremely tender in the early stage of their growth, require to be pushed forward into luxuriant vegetation with the least possible delay, by means of short dung.

4587. *The season when manure is applied*, is also a material circumstance. In spring and summer, whether it be used for corn or green crops, the object is to produce an immediate effect, and it should therefore be more completely decomposed than may be necessary, when it is laid on in autumn for a crop whose condition will be almost stationary for many months. (*Sup. Ency. Brit. art. Agr.*)

SUBJECT. 2. *Of Lime and its Management as a Manure.*

4588. *Lime is by far the most important of the fossile manures*; and indeed it may be asserted that no soil will ever be fit for much, that does not contain a proportion of this earth, either naturally or by artificial application. Next to farm-yard dung, lime is in most general use as a manure, though it is one of a quite different character; and when judiciously applied and the land laid to pasture, or cultivated for white and green crops alternately, with an adequate allowance of putrescent manure, its effects are much more lasting, and, in many instances, still more beneficial than those of farm-yard dung. Fossil manures, Sir H. Davy observes, must produce their effect, either by becoming a constituent part of the plant, or by acting upon its more essential food, so as to render it more fitted for the purposes of vegetable life. It is, perhaps, in the former of these ways, that wheat and some other plants are brought to perfection after lime has been applied, upon land that would not bring them to maturity by the most liberal use of dung alone. This being an established fact may be considered one of the greatest importance to all cultivators.

4589. *With regard to the quantity of lime that ought to be applied to different soils*, it is much to be regretted that Sir Humphrey Davy has not thought proper to enter fully into the subject. Clays, it is well known, require a larger quantity than sands or dry loams. It has been applied, accordingly, in almost every quantity from 100 to 500 bushels or upwards, per acre. About 160 bushels are generally considered a full dressing for lighter soils, and 80 or 100 bushels more for heavy cohesive soils.

4590. *In the application of lime to arable land*, there are some general rules commonly attended to by diligent farmers, which we shall give nearly in the words of a recent publication.

1. As the effects of lime greatly depend on its intimate admixture with the surface soil, it is essential to have it in a powdery state at the time it is applied.

2. Lime having a tendency to sink in the soil, it should be ploughed in with a shallow furrow.

3. Lime may either be applied to grass land, or to land in preparation for green crops or summer fallow, with almost equal advantage; but, in general, the latter mode of application is to be preferred.

4. Lime ought not to be applied a second time to moorish soils, unless mixed up as a compost, after which the land should be immediately laid down to grass.

5. Upon fresh land, the effect of lime is much superior to that of dung. The ground, likewise, more especially where it is of a strong nature, is more easily wrought; in some instances, it is said, the saving of labor would be sufficient to induce a farmer to lime his land, were no greater benefit derived from the application than the opportunity thereby gained of working it in a more perfect manner. (*General Report of Scotland*, vol. ii. p. 536.)

4591. *In liming for improving hilly land, with a view to pasture*, a much smaller quantity has been found to produce permanent and highly beneficial effects, when kept as much as possible near the surface, by being merely harrowed in with the seeds, after a fallow or green crop, instead of being buried by the plough. As this is a matter of much importance to farmers of such land, especially when lime must be brought from a great distance, as was the case in the instance to which we are about to allude, the successful practice of one of the most eminent farmers in Britain cannot be too generally known. A few years after 1754, says Dawson, "having a considerable extent of outfield land in fallow, which I wished to lime previous to its being laid down to pasture, and finding that I could not obtain a sufficient quantity of lime for the whole in proper time, I was induced, from observing the effects of fine loam upon the surface of similar soil, even when covered with bent, to try a small quantity of lime on the surface of this fallow, instead of a larger quantity ploughed down in the usual manner. Accordingly in the autumn, about twenty acres of it were well harrowed, and then about fifty-six Winchester bushels only of unslacked lime were, after being slacked, carefully spread upon each English acre, and immediately well harrowed in. As many pieces of the lime, which had not been fully slacked at first, were gradually reduced to powder by the dews and moisture of the earth, to mix these with the soil, the land was again well harrowed in three or four days thereafter. This land was sown in the spring with oats, with white and red clover and rye-grass seeds, and well harrowed, without being ploughed again. The crop of oats was good; the plants of grass sufficiently numerous and healthy; and they formed a very fine pasture, which continued good until ploughed some years after for corn. About twelve years afterwards, I took a lease of the hilly farm of Grubbet; many parts of which, though of an earthy mould tolerably deep, were too steep and elevated to be kept in tillage. As these lands had been much exhausted by cropping, and were full of couch-grass, to destroy that and procure a cover of fine grass, I followed them, and laid on the same quantity of lime per acre, then harrowed, and sowed oats and grass seeds in the spring exactly as in the last mentioned experiment. The oats were a full crop, and the plants of grass abundant. Several of these fields have been now above thirty years in pasture, and are still producing white clover, and other fine grasses; no bent or fog has yet appeared upon them. It deserves particular notice, that more than treble the quantity of lime was laid upon fields adjoining, of a similar soil, but which being

fitter for occasional tillage, upon them the lime was ploughed in. These fields were also sown with oats and grass-seeds. The latter thrived well and gave a fine pasture the first year; but afterwards the bent spread so fast, that, in three years, there was more of it than of the finer grasses."

4592. *The conclusions* which Dawson draws from his extensive practice in the use of lime and dung, deserve the attention of all cultivators of similar land.

1. That animal dung dropped upon coarse, benty pastures, produces little or no improvement upon them; and that, even when sheep or cattle are confined to a small space, as in the case of folding, their dung ceases to produce any beneficial effect, after a few years, whether the land is continued in pasture, or brought under the plough.

2. That even when land of this description is well fallowed and dunged, but not limed, though the dung augments the produce of the subsequent crop of grain, and of grass also for two or three years, that thereafter its effects are no longer discernible either upon the one or the other.

3. That when this land is limed, if the lime is kept upon the surface of the soil, or well mixed with it, and then laid down to pasture, the finer grasses continue in possession of the soil, even in elevated and exposed situations, for a great many years, to the exclusion of bent and moss. In the case of Grubbet hills, it was observed, that more than thirty years have now elapsed. Besides this, the dung of the animals pastured upon such land adds every year to the luxuriance, and improves the quality of the pasture; and augments the productive powers of the soil when afterwards ploughed for grain; thus producing, upon a benty outfield soil, effects similar to what are experienced when rich infield lands have been long in pasture, and which are thereby more and more enriched.

4. That when a large quantity of lime is laid on such land, and ploughed down deep, the same effects will not be produced, whether in respect to the permanent fineness of the pasture, its gradual amelioration by the dung of the animals pastured on it, or its fertility when afterwards in tillage. On the contrary, unless the surface is fully mixed with lime, the coarse grasses will in a few years regain possession of the soil, and the dung thereafter deposited by cattle will not enrich the land for subsequent tillage.

*Lastly.* It also appears from what has been stated, that the four shift husbandry is only proper for very rich land, or in situations where there is a full command of dung. That by far the greatest part of the land of this country requires to be continued in grass two, three, four, or more years, according to its natural poverty; that the objection made to this, viz. that the coarse grasses in a few years usurp possession of the soil, must be owing to the surface soil not being sufficiently mixed with lime, the lime having been covered too deep by the plough. (*Farmer's Magazine*, vol. xiii. p. 69.)

#### SECT. IV. *Of Composts of Earth, Lime, and Dung.*

4593. *Mixing farm yard dung, in a state of fermentation, with earth*, in which there is much inert vegetable matter; as the banks of old ditches, or what is collected from the sides of lanes, &c., will bring this inert, dead matter, consisting of the roots of decayed grasses and other plants, into a state of putridity and solubility, and prepare it for nourishing the crops or plants it may be applied to, in the very manner it acts on peat. Dung, however, mixed with earth, taken from rich arable fields which have been long cultivated and manured, can have no effect as manure to other land that the same earth and dung would not produce applied separately; because there is generally no inert matter in this description of earth to be rendered soluble.

4594. *Mixing dung, earth, and quick-lime together*, can never be advisable; because quick-lime will render some of the most valuable parts of the dung insoluble. (See 2223.) It will depend on the nature of soil or earth, whether even quick-lime only should be mixed with it to form compost. If there be much inert vegetable matter in the earth, the quick-lime will prepare it for becoming food for the plants it may be applied to; but if rich earth be taken from arable fields, the bottoms of dung-pits, or, in fact, if any soil full of soluble matter be used, the quick-lime will decompose parts of this soluble matter, combine with other parts, and render the whole mass less nourishing as manure to plants or crops, than before the quick-lime was applied to it. Making composts, then, of rich soil of this description, with dung or lime, mixed or separate, is evidently, to say no more of it, a waste of time and labor. The mixtures of earths of this description with dung produces no alteration in the component parts of the earth, where there is no inert vegetable substances to be acted on; and the mixture of earth full of soluble matter with dung and quick-lime, in a mass together, has the worst effects, the quick-lime decomposing and uniting with the soluble matter of the earth, as well as that of the dung; thus rendering both, in every case, less efficient as manures, than if applied separately from the quick-lime, and even the quick-lime itself inferior as manure for certain soils, than if it had never been mixed with the dung and earth at all. (*Farmer's Magazine*, vol. xv. p. 351.)

4595. *Mixing dung in a state of fermentation with peat*, or forming what in Scotland are called meadow-bank middens (2177.) is a successful mode of increasing the quantity of putrescent manure. The peat being dug and partially dried may either be carted into the farm-yard and spread over the cattle court, there to remain till the whole is carted out and laid upon a dunghill to ferment; or it may be mixed up with the farm-yard dung as carted out. If care be taken to watch the fermenting process, as the fire of a clay kiln is watched, a few loads of dung may be made to rot many loads of peat. Adding lime to such composts does not in the least promote fermentation, while it renders the most valuable parts of the mass insoluble. Adding sand, ashes, or earth, by tending to consolidate the mass, will considerably impede the progress of fermentation.

## CHAP. II.

*Of the Culture of the Cereal Grasses.*

4596. *The corn crops* cultivated in Britain are, wheat, rye, barley, and oats. Other culmiferous plants, as the maize, millet, and rice, have been tried with partial success in warm districts, but they have no chance whatever of ever becoming general in our climate.

4597. *On the culture of culmiferous plants*, a few general remarks may be of use to the young farmer. Culmiferous plants, like most others, have two sets of roots. The first originate with the germination of the grain, and are always under the soil, and are called the seminal roots; the second spring from the first joint which is formed above the surface of the soil, and from that joint strike down into the soil; these are called the coronal roots. The coronal roots appear chiefly intended for drawing nourishment from the soil; and, as Professor Martyn has observed, are judiciously placed for this purpose, the richest part of all soils being on or near the surface. These fibres are of larger diameter, more succulent, and never so long as the seminal or tap-root. From these facts as to the roots of culmiferous plants, some important hints may be derived as to their culture. The use of stirring the surface in spring to facilitate the entrance of the coronal roots, is obvious; the immediate effect of a top-dressing is also apparent, and also that manures may be ploughed in too deep to give the full amount of their beneficial effects to corn crops or grasses. Sagret, a scientific French agriculturist, proved experimentally, that where any of the grains or grasses are etiolated immediately after germination, by growing too rapidly, or being sown too thick, or in too warm a season, the first joint from which the coronal or nourishing roots spring, is raised above the ground, and in consequence either throws out no roots at all, or so few, as to nourish it imperfectly, in which case it either dies before it comes into flower, or before the seed is matured. (*Mem. de la Soc. Ag. de Seine*, tom. ii.)

4598. *The nutritive products* of the plants to be treated of in this section, are thus given by Sir H. Davy.

Systematic Names.	English Names. The quantity analysed, of each sort 1000 parts.	Whole quantity of soluble or nutritive matter.	Mucilage or starch.	Saccharine matter or sugar.	Gluten or albumen.	Extract, or matter rendered insoluble during the operation.
Triticum hybernum æstivum	Middlesex wheat, average crop	955	765	—	190	
	Spring wheat	940	700	—	240	
	Mildewed wheat of 1806	210	178	—	32	
	Blighted wheat of 1804	650	520	—	130	
	Thick-skinned Sicilian wheat of 1810	955	725	—	230	
	Thin-skinned Sicilian wheat of 1810	961	722	—	239	
	Wheat from Poland	950	750	—	200	
Hordeum vulgare	North American wheat	955	730	—	225	
	Norfolk barley	920	790	70	60	
Avena sativa	Oats from Scotland	743	641	15	87	
Secale cereale	Rye from Yorkshire	792	645	38	109	

SECT. I. *Wheat*. — *Triticum*, L. *Triandria digynia*, L. and *Gramineæ*, J. *Fruentum*, Fr.; *Weitzen*, Ger.; and *Grano*, Ital.

4599. Wheat is by far *the most important of the cereal grasses*, the flour made from its grains or seeds, from the quantity of gluten it contains, making the best bread in the world. A greater proportion of mankind are nourished by rice than by wheat, but there is no grain which comes near this species in its qualities for bread-making. Rice and maize are comparatively unfit for it, and oats, barley, and rye but imperfectly so. Rye, however, comes nearer to wheat in its bread-making qualities, than any other grain.

4600. *Of what country wheat is a native*, is totally unknown; it has been supposed of Asia and Africa, and unquestionably it is more likely to belong to these parts of the world than any other; but all that can be advanced on this subject is conjecture. Wheat, with the exception as it is said of some parts of the southern coast of Africa, is cultivated in every part of the temperate and torrid zones, and in some places as high as 2000 feet above the level of the sea. It has been cultivated from time immemorial in Britain, but in few places at a greater elevation than 600 feet. Of course the elevation to which any plant can be cultivated, always depends on the latitude of the situation.

4601. *Species and varieties*. (*fig. 553*.) Botanists reckon seven species of triticum, which are or may be cultivated for their grains, besides many varieties and subvarieties of those in common culture. The species or subspecies are,

1. *Triticum æstivum*, Summer wheat or spring wheat (*a*).
2. *hybernum*, Lammas wheat (*b*).
3. *compositum*, Egyptian wheat (*c*).
4. *turgidum*, Turgid wheat (*d*).
5. *Triticum polonicum*, Polish wheat (*e*).
6. *spelta*, Spelt wheat (*f*).
7. *monococcum*, One-grained wheat (*g*).



The first, second, fourth, and fifth sorts, are by many botanists considered as only varieties, and it is doubtful whether the third and sixth may not be the same; the seventh has all the marks of a distinct species, but it is very questionable whether, if much cultivated, it would always continue to produce one row of grains.

4602. *The spring or summer wheat (a)* is distinguished from that generally sown, by its narrower ears, longer beards, smaller grains, and shorter and more slender straw, and also, that it will not endure our winters. It is commonly sown in April, or even so late as May. It was known to Parkinson in 1666, but has never been much cultivated, excepting in Lincolnshire. It was tried and given up in Northumberland and Mid Lothian, and also in some counties near London. Many varieties of summer wheat were transmitted a few years ago to the president of the Board of Agriculture from the Agricultural Society of Paris, for the purpose of experiment, and were divided among several distinguished agriculturists, (*Communications to the Board of Agriculture*, vol. vii. p. 11.); but there has not yet been time for establishing their comparative merits, or their adaptation to the climate of Britain. Summer, or as it is often called, spring wheat, has however been long and extensively cultivated in some parts of England, particularly in Lincolnshire; and it is probable may be found a valuable crop in the southern counties; but the trials that have been made in the north, do not seem to entitle it to a preference over winter wheat sown in spring, or even oats or barley, in that climate.

4603. *Of the winter or common wheat (b)*, there are a great number of varieties. Professor Martyn, in Miller's Dictionary, has described forty-nine sorts, and Professor Thaer speaks of a hundred, but affirms that those who describe them know nothing about them, and in all probability include one sort under different names. All the varieties may be reduced to two, the white, and the brown or red grained. As subvarieties, there are the bearded and beardless, the woolly-chaffed, and thin or hairy chaffed, both of the reds and whites. To these some add another variety, which is the spring-sowing common wheat. It is stated by those who maintain that this variety exists, that through long sowing, the progeny, after a number of generations, acquires a habit of coming earlier into blossom than seed from winter-sown grain. This we think very likely, but are not aware that the variety is distinctly known by any recognizable marks in the plants. The red or brown wheats are universally considered as more hardy than the white, but as yielding an inferior flour: the woolly-white is supposed to yield the best flour; but woolly-chaffed wheats are considered as more liable to the mildew than any other.

4604. *The Egyptian, or many-spiked wheat (c)*, the turgid grey pollard or duck-bill wheat (*d*), and the Polish wheat (*e*), may, for all agricultural purposes, be considered as only varieties of the common winter wheat. They are cultivated in a few places in England, and seeds of them may be procured from the public botanic gardens; but they are in little estimation.

4605. *Spelt wheat (f)*, the *epautre* of the French, is known by its stout straw, which is almost solid, and by its strong spikes, with chaff partially awned, the awns long and stiff. The chaff adheres so close to the grain as not to be separated without great difficulty. This grain, as we have seen, is a good deal sown in the south of Europe. In France it is sown in spring, on land too coarse for common wheat, and it ripens in July and August. It is the principal wheat sown in Suabia and the north of Switzerland; and is a good deal sown in Spain. The grain is light, and yields but little flour; but it is said to contain a larger portion of gluten than common wheat, and for that reason is recommended as superior to any other in pastry and confectionary. It is not cultivated in Britain.

4606. *The one-grained wheat (g)* is known by its small thin spike, and single row of grains; the leaves and straw are remarkably small, but very hard; and the plants tiller remarkably. It is chiefly cultivated in the mountainous parts of Switzerland, where its straw, like that of the former species, is much used for thatching. The grain makes a brown light bread; but its great excellence, according to Villars, is for gruel.

4607. *To procure new varieties of wheats*, the ordinary mode is to select from a field a spike or spikes from the same stalk, which has the qualities sought for; such as larger grains, thinner chaff, stiffer straw, a tendency to earliness or lateness, &c.; and picking out the best grains from this ear or ears, to sow them in suitable soil in an open airy part of a garden. When the produce is ripe, select the best ears, and from these the best grains, and sow these, and so on till a bushel or more is obtained, which may then be sown in a field apart from any other wheat. In this way, many of the varieties of our common winter wheat have been obtained; as the hedge-wheat which was reared from the produce of a stalk found growing in a hedge in Sussex, by one Wood, about 1790. Other varieties have assumed their distinctive marks from having been long cultivated on the same soil and climate, and take local names, as the Hertfordshire red, Essex white, &c.

4608. *Marshal* (Yorkshire) mentions a case in which a man of *accurate* observation, having, in a piece of wheat perceived a plant of uncommon strength and luxuriance, diffusing its branches on every side, and setting its closely-surrounding neighbors at defiance, marked it; and at harvest removed it separately. The produce was 15 ears, yielding 604 grains of a strong-bodied liver-colored wheat, differing in general appearance, from every other variety he had seen. The chaff was smooth, without awns, and of the color of the grain; the straws stout and reedy. These 604 grains were planted singly, nine inches asunder, filling about 40 square yards of ground, on a clover stubble, the remainder of the ground being sown with wheat in the ordinary way; by which means extraordinary trouble and destruction by birds were avoided. The produce was two gallons and a half weighing 20½ lbs. of prime grain for seed, besides some pounds for seconds. One grain produced 35 ears, yielding 1235 grains; so that the second year's produce was sufficient to plant an acre of ground. What deters farmers from improvements of this nature is probably the mischievousness of birds; from which at harvest it is scarcely possible to preserve a small patch of corn especially in a garden or other ground situated near a habitation; but by carrying on the improvement in a field of corn of the same nature, that inconvenience is got rid of. In this situation, however, the botanist will be apprehensive of danger from the floral farina of the surrounding crop. But from what observations *Marshal* has made he is of opinion his fears will be groundless. No evil of this kind occurred, though the cultivation of the above variety was carried on among *white* wheat.

4609. *But the most systematic mode of procuring new varieties*, is by crossing two sorts, as in breeding: that is, by impregnating the female organs of the blossoms of one ear with the fecundating matter or pollen of the male organs of the blossom of another variety of a different quality. Thus, supposing a farmer wished to render a very good variety which he was in the habit of cultivating somewhat earlier. Let him procure in the blossoming season, from a very early soil, some spikes of an early sort just coming into blossom, and let him put the ends of these in water and set them in the shade so as to retard their fully blossoming till the plants he has destined to become the females come into flower. Then let him cut out all the male organs of the latter before they have advanced so far as to impregnate the stigma; and having done this, let him dust the stigma with the blossoming ears of the early or male parent. The impregnated stalks must then be kept apart from other wheats so as the progeny may be true. When the grains ripen, sow the best, and from the produce when ripe, select the earliest and finest spikes for seed. Sow them and repeat the choice till a bushel or two of seed is procured. This operation has been successfully performed by T. A. Knight (1600.), and though it may be reckoned too delicate for farmers in general, it will be looked on by the philosophical agriculturist as not improbably leading to as important results as has attended the practice in the case of garden fruits and flowers.

4610. *The propagation of wheat by transplanting* may be employed to expedite the progress of cultivating a new variety of ascertained excellence. To show what may be gained in time by this mode, we shall quote from *The Philosophical Transactions* an account of an experiment made by C. Miller, son of the celebrated gardener of that name, in 1766. On the 2nd of June, Miller sowed some grains of the common red wheat; and on the 8th of August, a single plant was taken up and separated into 18 parts, and each part planted separately. These plants having pushed out several side shoots, by about the middle of September, some of them were then taken up and divided, and the rest of them between that time and the middle of October. This second division produced 67 plants. These plants remained through the winter, and another division of them, made about the middle of March and the 12th of April, produced 500 plants. They were then divided no further, but permitted to remain. The plants were, in general, stronger than any of the wheat in the fields. Some of them produced upwards of 100 ears from a single root. Many of the ears measured seven inches in length and contained between 60 and 70 grains. The whole number of ears which, by the process above-mentioned, were produced from one grain of wheat, was 21,109, which yielded three pecks and three quarters of clean corn, the weight of which was 47 lbs. 7 ounces; and from a calculation made by counting the number of grains in an ounce, the whole number of grains was about 386,840. By this account we find, that there was only one general division of the plants made in the spring. Had a second been made, Miller thinks the number of plants would have amounted to 2000 instead of 500, and the produce thereby been much enlarged.

4611. *In making a choice from all the species and varieties* which we have named, the thin-skinned white wheats are preferred by all the best British farmers whose soil and climate are suitable for this grain, and for sowing in autumn. In late situations, and less favorable soils and climates, the red varieties are generally made choice of; and these are also generally preferred for sowing in spring. Red wheats, however, are considered as at least fifteen per cent. less valuable than the white varieties. No sub-variety ever continues very long in vogue; nor is it fitting that it should, as degeneracy soon takes place, and another and better is sought for as a successor. Hence the only recommendation we can give as to the choice of subvarieties, is to select the best from among those in use by the best farmers in the given situation, or nearest well-cultivated district.

4612. *The soils best adapted for the culture of wheat*, are rich clays and heavy loams; but these are not by any means the only description of soils on which it is cultivated. Before the introduction of turnips and clover, all soils but little cohesive were thought quite unfit for wheat; but even on sandy soils, it is now grown extensively, and with much advantage after either of these crops. The greater part of the wheat crop throughout Britain, however, is probably still sown upon fallowed land. When it succeeds turnips consumed on the ground, or clover cut for hay or soiling, it is commonly sown after one ploughing; but upon heavier soils, or after grass of two or more years, the land is ploughed twice or three times, or receives what is called a rag fallow. (*Supp. Encyc. Brit.* art. *Agr.*)

4613. *On rich clays*, wheat may be cultivated almost every second year, provided due care



is taken to keep the land clean, and in good condition. A summer fallow once in four, six, or eight years, according to seasons and circumstances, is, however, necessary; and manure should either be applied on that fallow for the first crop of wheat, or, what some people think preferable, should be laid on the wheat-stubble for a crop of drilled beans, which ensures the succeeding crop of wheat. If the first crop of beans has been completely cleaned, there is no difficulty of repeating, and even of extending the course; and the crops will be little inferior to those gained at the beginning of the rotation, provided manure has been bestowed to each crop of beans. In this way, when the ground is fallowed every fourth year, two crops of wheat and one of beans are gained from manuring once; when fallowed every sixth year, three crops of wheat and two of beans are gained from manuring twice; and, when fallowed every eighth year, four crops of wheat and three of beans from manuring thrice. In the first-mentioned shift, less manure is bestowed than in any of the other two; and if the soil is of good quality, it will support itself; whereas, in the shifts of six and eight, unless foreign manure is procured, it rarely happens that they can go on successfully for any length of time, without abstracting dung from other parts of the farm on which they are practised. (*Brown's Tr. on Rural Affairs.*)

4614. *In cultivating wheat on thin clays*, the rotations just mentioned are inapplicable. A six-course shift of a different kind has, however, been successfully followed by many people; but it requires every branch of the work to be well executed. 1st, a summer fallow, dunged at the rate of twelve or fourteen double loads per acre; 2d, wheat; 3d, grass; 4th, oats; 5th, pease and beans drilled; 6th, wheat. If manure can be given in the middle of the shift, every one of the crops may be expected good; but if that is withheld, there will necessarily be a proportionable falling off in the two last crops. Husbandmen must, however, regulate their practice according to their means; though it deserves to be remarked, that, if greater attention were paid to the collecting of materials which ultimately are converted into manure, many deficiencies in the article would be fully supplied. (*Brown*)

4615. *Excellent wheat may be grown on light soils*, with the exception of soft sands. Such soils, however, are not constitutionally disposed to the growth of that grain; nor will they, under any management, bear such a frequent repetition of it as those already mentioned. Summer fallow on them may safely be dispensed with; because a crop of turnips, which admits every branch of the cleaning process to be more perfectly executed than even a naked or bare fallow does, may be profitably substituted. Wheat here comes in with propriety after turnips, though, in general cases, it must be sown in the spring months, unless the turnips are stored; in which case, it may be sown in November, or it may be sown after clover, for the fourth crop after the rotation; or in the sixth year, as a way-going crop, after drilled pease and beans, if the rotation is extended to that length. But, take it any way, it is scarcely possible to raise wheat so extensively upon light soils, even where they are of the richest quality, as is practicable upon clays; nor will a crop of equal bulk upon the one, return so much produce in grain as may be got from the other. To enlarge upon this point would only serve to prove what few husbandmen will dispute, though, it may be added, that, on thin sands, wheat ought not to be ventured, unless they are either completely clayed or marled, as it is only with the help of these auxiliaries that such a soil can gain stamina capable of producing wheat with any degree of success. (*Brown.*)

4616. *The culture of the soil intended for wheat varies according to its nature*, and the preceding and following crops. "On soils really calculated for wheat, though in different degrees, summer fallow is the first and leading step to gain a good crop or crops of that grain. The first furrow should be given before winter, or so early as other operations upon the farm will admit; and every attention should be used to go as deep as possible; for it rarely happens that any of the succeeding furrows exceed the first one in that respect. The number of after-ploughings must be regulated by the condition of the ground and the state of the weather; but, in general, it may be observed, that ploughing in length and across, alternately, is the way by which the ground will be most completely cut, and the intention of fallowing accomplished. It has been argued, that harrowing clay soils, when summer fallowed, is prejudicial to the wheat crop; but, without discussing this point (such a discussion being unnecessary), it may merely be stated, that, in a dry season, it is almost impracticable to reduce real clays, or to work them too small; and that, even in a wet one, supposing they are made surface-smooth, they will, when ploughed up again, consolidate into clods or big lumps after forty-eight hours' drought, and become nearly as obdurate as ever. It is only on thin soils, which have a mixture of peat earth, and are incumbent on a bottom impervious to water, that damage is at any time sustained by over harrowing. Such are generally of a weak texture, and may be broken down with facility by the roller and harrow. If caught by much rain before the pores are in some measure closed, the moisture is greedily absorbed; and being prevented from going downwards by the hardness of the subsoil, the

whole surface becomes a kind of mortar or paste, unless previously well ridged up; which, to a certain extent, prevents the consequences from being dangerous. These evils, however, must be submitted to by the possessors of such soils, if they want to have them sufficiently fallowed and prepared in a proper manner; for, without reducing them, couch-grass, and especially moss, with which they are commonly stored, cannot be eradicated. If they are reduced in the early part of the season, the danger is small; but to break them down in the latter part ought always to be avoided, unless called for by imperious necessity.

4617. When *wheat is sown after beans*, it rarely happens, in this northern climate, that more than one ploughing can successfully be bestowed. Before this is given, it is advantageous to cross-harrow the land, which levels the drills, and permits the ploughing process to be executed with precision. Almost in every case, the ridges should be gathered up, so that the furrows may be well cleared out, and the plants preserved from injury during the inclement winter season. Clover land should be neatly ploughed, and well laid over, so that the roots of the grasses may be buried and destroyed; for it frequently happens, that crops of wheat after clover and rye-grass, are greatly injured by inattention to the ploughing process. In short, sowing wheat after clover may be considered as the most hazardous way in which that grain can be cultivated. (*Brown's Tr. on Rural Affairs.*)

4618. *The manures* best calculated for wheat, are allowed by all agricultural chemists to be animal matters and lime. The former has a direct influence in supplying that essential constituent to wheaten flour, gluten; and the latter azote and lime, both actually found in the straw of wheat. At all events, it is certain wheat will not thrive on any soil that does not contain lime. In this, Sir H. Davy, Chaptal, Professor Thaer, and Grisenhwaite fully agree.

4619. *A more abundant supply of manure* is generally required for wheat than for any other grain. Professor Thaer says it absorbs more nourishment from the soil than any of the corn tribe; and he calculates (hypothetically, as he allows; that for every 100 parts of nutriment in a soil sown with this grain, 40 will be carried off by the crop. (*Principes Raisonné*, tom. iv. art. *Froment.*) At the same time too large a dose of manure on land in good tilth is very apt to cause the crop to lodge; and hence some people think it improper to dung rich clays or loams when fallowed, and choose rather to reserve that restorative till the succeeding season, when they are prepared for a crop of drilled beans. Delaying the manuring process for a year is attended with many advantages; because good land, fully wrought, contains such a principle of action within itself, as often causes the first wheat crop to be lodged before it is filled; under which circumstance, the produce is diminished both in quantity and quality. This delay in manuring is, however, attended with disadvantages; because, when dung is kept back till the end of autumn or beginning of winter, to be laid on the stubbles, the weather is often so wet that it cannot be carted on without subjecting the land to injury from poaching, whilst the labor in laying it on is also increased. On thin clays, or even upon soils of the other description not in high condition, there can be no doubt but that the end of summer, and upon summer fallow, is the most proper time for manuring them, though it will be found that an improvident expenditure of dung, on such occasions, ought always to be steadily avoided. (*Brown.*)

4620. *Where manure is abundant*, wheat alternating with a green crop, or indeed, any corn crop and a green crop may be grown alternately for any length of time. (*Farm. Mag.* vol. xxiii. p. 298.)

4621. *The climate* required to bring wheat to perfection must be such as affords a dry and warm season for the blossoming of the ear, and the ripening of the grain. Wheat will endure a great deal of cold during winter, if sown in a dry or well drained soil; and if it be covered with snow. Hence it is that wheat is sown as far north as Petersburg and in Sweden. Moderately moist weather before the flowering season, and after the grain is set or formed, is favorable to wheat; but continued heavy rains after the flowering season produces the smut. The dry frosty winds of February and March, and even April in some districts, are more injurious to the wheats of Britain than any other description of weather. Hoar frosts, when the plant is in the ear, produce blights; and mildews often result from or follow sultry winds and fogs. Cold, in the blossoming and ripening season in July, even unaccompanied by wind or rain, produces an inferior grain, greatly deficient in gluten; and heat the contrary. The most valuable wheat of Europe in this respect, is that of Sicily; which Sir H. Davy found to contain much more gluten than the best wheat of Britain.

4622. *The season of sowing* wheat on clays is generally the latter end of autumn; but on early turnip soils it is sown after clover or turnips, at almost every period from the beginning of September till the middle of March; but the far greater part is sown in September and October. For summer wheat in the southern districts, May is sufficiently early, but in the north, the last fortnight of April is thought a more eligible seed-time. In the cultivation of spring-sown winter wheat, it is of importance to use the produce of

spring-sown grain as seed, as the crop of such grain ripens about a fortnight earlier than when the produce of the same wheat winter-sown is employed as spring seed. (*Encyc. Brit. art. Agr.*)

4623. *Seed wheat is prepared for sowing by the process called pickling.* According to Brown (*Treatise on Rural Affairs*, art. *Wheat*), this process is indispensably necessary on every soil; otherwise smut, to a greater or less extent, will, in nine cases out of ten, assuredly follow. Though almost all practical farmers are agreed as to the necessity of pickling, yet they are not so unanimous as to the *modus operandi* of the process, and the article which is best calculated to answer the intended purpose. Stale urine may be considered as the safest and surest pickle; and where it can be obtained in a sufficient quantity, is commonly resorted to. The mode of using it does not, however, seem to be agreed upon; for, while one party contends that the grain ought to be steeped in the urine, another party considers it as sufficient to sprinkle the urine upon it. Some, again, are advocates for a pickle made of salt and water, sufficiently strong to buoy up an egg, in which the grain is to be thoroughly steeped. But whatever difference of opinion there may be as to the kind of pickle that ought to be used, and the mode of using it, all admit the utility of mixing the wetted seed with hot lime, fresh slaked; and this, in one point of view, is absolutely necessary, so that the seed may be equally distributed. It may be remarked, that experience justifies the utility of all these modes, provided they are attentively carried into execution. There is some danger from the first; for if the seed steeped in urine is not immediately sown, it will infallibly lose its vegetative power. The second, viz. sprinkling the urine on the seed seems to be the safest, if performed by an attentive hand; whilst the last may do equally well, if such a quantity of salt be incorporated with the water, as to render it of sufficient strength. It may also be remarked, that this last mode is oftener accompanied with smut, owing no doubt to a deficiency of strength in the pickle; whereas a single head with smut is rarely discovered when urine has been used.

4624. *A new mode of preparing wheat for sowing has recently been adopted in the south of Scotland and followed with great success.* It is thus described: "Take four vessels, two of them smaller than the other two, the former with wire bottoms, and of a size to contain about a bushel of wheat, the latter large enough to hold the smaller within them. Fill one of the large tubs with water, and, putting the wheat in the small one, immerse it in the water and stir and skim off the grains that float above, and renew the water as often as is necessary, till it comes off almost quite clean. Then raise the small vessel in which the wheat is contained, and repeat the process with it in the other large tub, which is to be filled with stale urine; and in the meantime wash more wheat in the water tub. When abundance of water is at hand, this operation is by no means tedious; and the wheat is much more effectually cleansed from all impurities, and freed more completely from weak and unhealthy grains and seeds of weeds, than can be done by the winnowing machine. When thoroughly washed and skimmed, let it drain a little, then empty it on a clear floor or in the cart that is to take it to the field, and sift quick-lime upon it, turning it over and mixing it with a shovel, till it be sufficiently dry for sowing." (*Sup. E. Brit. art. Agr.*)

4625. *The quantity of seed necessary depends both on the time of sowing and the state of the land; land sown early requiring less than the same land when sown in winter or spring; and poor land being at all times allowed more seed than the rich.* The quantity accordingly varies from two bushels or less, to three, and sometimes even to four bushels per English statute acre. Winter wheat, when sown in spring, ought always to have a liberal allowance, as the plants have not time to tiller much without unduly retarding their maturation. (*Supp. &c.*) Upon well prepared lands, if the seed be distributed equally, it can scarcely be sown too thin; perhaps two bushels per acre are sufficient; for the heaviest crops at autumn are rarely those which shew the most vigorous appearance through the winter months. Bean stubbles require more seed than summer fallows; because the roughness of their surface prevents such an equal distribution; and clover layers ought to be still thicker sown than bean stubbles. Thin sowing in spring ought not to be practised, otherwise the crop will be late, and imperfectly ripened. (*Brown.*)

4626. *The modes of sowing wheat are either broad-cast, drilling, ribbing, or dibbling.* The first mode is by far the most general, and the seed is for the most part covered by the harrows. No more harrowing, Brown observes, should be given to fields that have been fallowed, than what is necessary to cover the seed, and level the surface sufficiently. Ground which is to lie in a broken down state through the winter, suffers severely when an excessive harrowing is given, especially if it is incumbent on a close bottom; though, as to the quantity necessary, none can give an opinion, except those who are personally present.

4627. *Ploughing in.* Many farmers allege that wheat which is harrowed in is apt to be thrown out in spring; or if not thrown out at that season, that it does not tiller well, and that the stalks are apt to dwindle away and fall down in the flowering season. It is certain that this is the case in many parts of England; and the cause assigned by the

northern farmers is the defective manner in which the land is ploughed, by which there is not sufficient covering for the seed. To guard against these evils it is a very general practice in most of the southern counties, when wheat is sown broad-cast, to plough it in with a shallow furrow. This is done even after beans and on clover leys, and is a favorite practice on very opposite soils, as in Norfolk and Middlesex.

4628. *Drilling*, however, is extensively practised in some districts, and is becoming more general on lands infested with the seeds of annual weeds, especially when sown in spring. A machine which sows at three different intervals, according to the judgment of the farmer, of twelve, ten and a half, or nine inches, is much approved of in the northern districts. It deposits six, seven, or eight rows at once, according as it is adjusted to one or other of these intervals, and the work is done with ease and accuracy when the ridges are previously laid out of such a breadth, twelve and a half feet, as to be sown by one bout; the machine going along one side of such a ridge, and returning on the other, and its direction being guided by one of its wheels, which thus always runs in the open furrow between the ridges. If the ten and a half inch interval be adopted, and it is the most common one in that country, the machine sows seven rows at once, or fourteen rows on a ridge of twelve feet and a half. But the space between the rows varies in some parts still more than this machine admits of; it ought not, however, to be so narrow as to prevent hand hoeing, even after the crop has made considerable progress in growth; and it cannot advantageously be so wide as to admit the use of any effective horse-hoe.

4629. *Ribbing is a mode of sowing common in some places*, by which a drill machine is dispensed with, though the same purpose is nearly answered. This is what is called *ribbing*, which we have already adverted to in the section on tillage. The seed is scattered with the hand in the usual broad-cast manner, but as it necessarily falls for the most part in the furrows between the ribs, the crop rises in straight parallel rows, as if it had been sown by a drill machine; after sowing the ribs are levelled by harrowing across them. This plan has nearly all the advantages of drilling in so far as regards exposure to the rays of the sun, and the circulation of air among the plants; but as some plants must always rise between the rows, it is not quite so proper when horse-hoeing is required. (*Sup. E. Brit.*)

4630. *The dibbling of wheat is practised in some parts of Norfolk*. The furrow is laid over flat, and a row of holes is made along the middle of each by a man who uses a dibber in each hand. A middling workman will make four holes in a second. One dibbler is sufficient for three droppers; whence one man and three children are called a *set*. The dibbler carries on three flags or turned furrows; going on some yards upon one of the outside furrows, and returning upon the other, after which he takes the middle one; and thus keeps his three droppers constantly employed; and at the same time is in no danger of filling up the holes with his feet. The droppers put in two or three grains of wheat into each hole; but much time and patience is necessary to teach them to perform the business properly and quickly. An expert dibbler will hole half an acre in a day; though one-third of an acre is usually reckoned a good day's work. The seed is covered by means of a bush harrow; and from one bushel to six pecks is the usual quantity for an acre. Notwithstanding the advantages of saving seed, as well as some others which are generally reckoned undeniable, it is asserted by some very judicious farmers, that dibbling of wheat on the whole is not really a profitable practice. It is particularly said to be productive of weeds unless dibbled very thick: which indeed may probably be the case as the weeds are thus allowed a greater space to vegetate in. Marshal is of opinion, that the dibbling of wheat appears to be peculiarly adapted to deep rich soils, on which three or four pecks dibbled early may spread sufficiently for a full crop; whereas light, weak, shallow soils, which have lain two or three years, and have become grassy, require an additional quantity of seed, and consequently an addition of labor, otherwise the plants are not able to reach each other, and the grasses of course find their way up between them, by which means the crop is injured and the soil rendered foul. If a single grain of good size and sound, could be dropt in each hole and no more, there might be an advantage in dibbling where it could be accomplished at a moderate rate; but where two or three grains are put in each hole, and often six or eight, the source of profit is diminished or destroyed by twofold means; first, by using too much seed; and secondly, because three or four grains springing out of one hole will not make such a strong plant or stool as one sound grain. The only way in which we can conceive dibbling likely to answer is by the use of a machine such as that invented by Plunkett (2469.), but which never came into use. To attempt dibbling either wheat or beans by hand on a large scale, we consider as quite unsuitable for the present improved state of agriculture.

4631. *The after culture of wheat*, or culture of the growing crop, depends on the manner in which it has been sown. When wheat is sown broad-cast, the subsequent culture must generally be confined to harrowing, rolling, and hand-hoeing. As grass seeds are frequently sown in spring on winter-sown wheat, the harrows and roller are employed to loosen the soil, and cover the seeds. But these operations, to a certain extent, and at the proper season, are found beneficial to the wheat crop itself, and are sometimes performed even when grass seeds are not to be sown. One or two courses of harrowing penetrate the crust which is formed on tenacious soils, and operate like hand-hoeing in raising a fresh mould to the stems of the young plants. Rolling in spring ought never to be omitted on dry porous soils, which are frequently left in so loose a state by the winter frosts, that the

roots quit the soil and perish; and if the land be rough and cloddy, the roller has a still more beneficial effect than the harrows in pulverising the inert masses, and extending the pasture of the plants. Hand-weeding, so far as to cut down thistles and other long weeds, is never neglected by careful farmers; but the previous culture ought to leave as little as possible of this work to be done when the crop is growing. (*Supp.*)

4632. *When wheat has been drilled, ribbed, or dibbled*, the intervals may be hoed or stirred either by hand-hoes, common or pronged, or by horse-hoes, or drill harrows. In general, the drill used at sowing, will by the changes it admits of in its double character of drill and horse-hoe, be the best to use for hoeing or stirring. Or if a single drill should have been used, the expanding horse-hoe, or Blakie's inverted horse-hoe, may be successfully adopted. The operation of hoeing or stirring should generally be performed in March, and need not be repeated. When grass-seeds are to be sown among the wheat, the hoeing is an excellent mode of covering them. Weeding the rows should not be neglected, nor delayed later than the beginning of June.

4633. *Where wheats rise too thin* in some places, and too thick in others, whether in rows or broad-cast, the practice of transplanting from the latter to the former has been recommended. This is said to be practised occasionally in Essex and Norfolk, and the time is the end of March. To be attended with success the soil must be in a good state, and the blanks to which the plants are to be transplanted, must be stirred up with a trowel or small two-pronged fork. Under such circumstances we have no doubt of the plan being attended with success; but we are certain that without stirring the soil, the operation will not pay for the expense. Blanks are sometimes filled up by sowing summer wheat, dibbling beans, &c. but these are obviously bad modes; a better is either to stir the soil well, and encourage the tillering of the plants, or to stir the soil and then transplant.

4634. *Top dressing wheat crops* has been recommended, in cases where the land is not in a sufficient state of fertility or preparation to bring the crops to perfection. Substances of both the solid and fluid kinds have been made use of for this purpose; the first consist chiefly of the dung of different sorts of birds after being brought into a powdery state, bone dust, soot, peat ashes, and various saline matters. The latter are principally the drainings of dunghills and other similar liquid materials. The former should be thinly sown over the crop with as much evenness as possible, as early in the spring as horses can be admitted upon the land without injury; and if it can be done when the weather is inclined to be moist, it is the better, a roller may then be passed over the crop with advantage. Where the latter substances are made use of, care should always be taken that the plants be not injured by having too large a quantity applied to them. In this practice the expense should be a primary consideration, and small trials first made where dungs have not been used. The proper season for performing the business is the beginning of February.

4635. *When wheat appears too forward and luxuriant*, it is sometimes eat down in April, with sheep or even with horses, but this requires great judgment to be effected without injuring the crop.

4636. In *harvesting wheat*, the best farmers both of Britain and the continent agree, that it ought to be cut before it become dead ripe. When the latter is the case, the loss is considerable, both in the field and stack-yard, and the grain, according to Professor Thaer, produces a less white flour. In ascertaining the proper state, Brown observes, it is necessary to discriminate betwixt the ripeness of the straw, and the ripeness of the grain; for, in some seasons, the straw dries upwards; under which circumstance, a field, to the eye, may appear to be completely fit for the sickle, when, in reality, the grain is imperfectly consolidated: and perhaps not much removed from a milky state. Though it is obvious that, under such circumstances, no further benefit can be conveyed from the root, and that nourishment is withheld the moment that the roots die; yet it does not follow, that grain so circumstanced should be immediately cut: because, after that operation is performed, it is in a great measure necessarily deprived of every benefit from the sun and air, both of which have greater influence in bringing it to maturity, so long as it remains on foot, than when cut down, whether laid on the ground, or bound up in sheaves. The state of the weather at the time also deserves notice; for, in moist, or even variable weather, every kind of grain, when cut prematurely, is more exposed to damage than when completely ripened. All these things will be studied by the skilful husbandman, who will also take into consideration the dangers which may follow, were he to permit his wheat crop to remain uncut till completely ripened. The danger from wind will not be lost sight of, especially if the season of the equinox approaches; even the quantity dropped in the field, and in the stack-yard, when wheat is over ripe, is an object of consideration. Taking all these things into view, it seems prudent to have wheat cut before it is fully ripe, as less damage will be sustained from acting in this way than by avoiding a contrary practice.

4637. *The mode of reaping wheat* is almost universally by the sickle. When cut, it is usually tied up in sheaves, which it is better to make so small as to be done by bands the

length of the straw, than so thick as to require two lengths to be joined for bands. The sheaves are set up in *shocks* or *stooks*, each containing in all twelve, or if the straw be long, fourteen sheaves. In the latter case, two rows of six sheaves are made to stand in such a manner as to be in contact at the top, though in order to admit the circulation of air they are placed at some distance below: along this line, two sheaves more are placed as a covering, the corn end of both being towards the extremities of the line. In a few days of good weather the crop is ready for the barn or stack-yard. In the stack-yard it is built either in oblong or circular stacks, sometimes on frames supported with pillars to prevent the access of vermin, and to secure the bottom from dampness; and as soon afterwards as possible the stacks are neatly thatched. When the harvest weather is so wet as to render it difficult to prevent the stacks from heating, it has been the practice to make funnels through them, a large one in a central and perpendicular direction, and small lateral ones to communicate with it. In the best cultivated counties the use of large barns for holding the crop is disapproved of, not only on account of the expense, but because corn keeps better, or is less exposed to damage of any kind in a well-built stack.

4638. *The threshing of wheat*, before machines for that purpose were introduced, was an arduous and difficult task. The expense was very considerable, whilst the severity of the labor almost exceeded the power of the strongest man, especially in unfavorable seasons, when the grain adhered pertinaciously to the ear, and could not, without difficulty, be completely loosened and removed. In such seasons, expense was the smallest consideration which influenced the husbandman; it was the quantity of grain unavoidably lost which occupied his attention; and, as it appeared difficult to find out a remedy, most people considered it as an evil which could scarcely be avoided. In short, the loss was great in almost every case, but greater with wheat than any other grain. Every thing of this nature, however, may be prevented, now that threshing machines are introduced, provided the feeder is careful, and proportions the quantity on the board to the strength of the impelling power. Wheat, in fact, is now the cleanest threshed grain; because the length of the straw allows it to be properly beat out before it passes the machine, which sometimes is not the case with short oats and barley. If horses are used as the impelling power, thin feeding is necessary, otherwise the animals may be injured; but where wind or water is employed, the business of threshing is executed speedily, completely, and economically. (*Brown.*)

4639. *In performing the operation* one man feeds the grain in the straw into the machine, and is assisted by two half-grown lads, or young women, one of whom pitches or carries the sheaves from the boy close to the threshing-stage, while the other opens the bands of every sheaf, and lays the sheaves successively on a small table close by the feeder, who spreads them evenly on the feeding stage, that they may be drawn in successively by the fluted rollers, to undergo the operation of threshing. In the opposite end of the barn or straw-house, into which the rakes or shakers deliver the clean threshed straw, one man forks up the straw from the floor to the *straw-mow*, and two lads, or young women, build it and tread it down. In a threshing-machine, worked by water or wind, this is the whole expense of hand labor in the threshing part of the operation, and as a powerful machine can easily thresh from two to three hundred bushels of grain in a working day of nine hours, the expense is exceedingly small indeed. Assuming two hundred and fifty bushels as an average of the work of these people for one day, and their wages to be nine shillings, the expense does not amount to one halfpenny for each bushel of grain. Even reducing the quantity of grain threshed to one hundred and fifty bushels, the easy work of a good machine of inferior size and power, the expense does not exceed three farthings the bushel. But the whole of this must not be charged against the threshing only, the grain being half dressed at the same time, by passing through one winnowing-machine, which is always attached to a complete threshing-mill; and where a second can be conveniently connected with it, as is commonly the case if of considerable power, the corn comes down nearly ready for market. So that the threshing, dressing, and building of the straw, with the use of a powerful water-mill, will scarcely cost more than dressing alone when the flail is employed; after every reasonable allowance for the interest of money, and the tear and wear of the machine.

4640. *When grain is threshed with a machine worked by horses*, the expense is necessarily and considerably enhanced. One capable of effecting the larger quantity of work, already calculated on, will require eight good horses, and a man to drive them, who may perhaps require the aid of a boy. The value of the work of eight horses for a day cannot be less than forty shillings, and the wages of the driver may be called two shillings and sixpence. Hence the total expense of threshing two hundred and fifty bushels will amount to *2l. 2s. 6d.*; or about two-pence per bushel, when the wages of the attendants are added; still leaving a considerable difference in favor of threshing by the machine, in preference to the flail. Were it even ascertained that the expense of threshing by horses and by the flail is nearly the same, horse-mills are to be recommended on other accounts; such as better threshing, expedition, little risk of pilfering, &c.

4641. *The produce of wheat* must of course vary according to the soil, climate, culture, and kind grown. Professor Thaer says, that in general it gives double the weight of straw that it does of grain; on elevated grounds something less; and on low grounds something more. An acre, therefore, which produces four quarters of wheat, weighing sixty-one pounds per bushel, ought to produce about  $177\frac{1}{2}$  cwt. of straw; two load, or  $22\frac{1}{2}$  cwt., however, is only reckoned a tolerable crop in this country. The yield of grain in some seasons has been under twenty; while in others it is upwards of thirty bushels the acre, the soil and culture being in every respect the same. The average produce of Britain has been estimated at three, three and a half, and four quarters; and one of the largest crops ever heard of, at ten quarters, and the least at one and a half quarter. The proportion which the corn bears to the straw, in Middlesex, is eleven and a half bushels to a load of thirty-six truss of thirty-six pounds each, or eleven and a half cwt.,

no great deviation from Professor Thær's general estimate, a bushel of wheat weighing about six or six and a half cwt.

4642. *To judge of a sample of wheat*, examine by the eye whether the grain be perfectly fed or full, plump and bright, and whether there be any adulteration proceeding from sprouted grains, smut, or the seeds of weeds; and by the smell, whether there be any improper impregnation, and whether it has been too much heated in the mow, or upon the kiln; and finally, by the feel, to decide if the grain be sufficiently dry; as when much loaded with moisture it is improper for the uses of the miller and baker. In cases where a sample handles coarse, rough, and does not slip readily in the hand, it may be concluded not to be in a condition either for grinding or laying up for keeping.

4643. *The yield of wheat in flour* is, on an average, thirteen pounds of flour to fourteen pounds of grain. In the chemical analysis of wheat, Sir Humphry Davy found that one hundred parts of good full-grained wheat, sown in autumn, yielded of starch seventy-seven, and of gluten nineteen. One hundred parts of wheat sown in spring, seventy of starch, and twenty-four of gluten. American wheats he found to contain more gluten than the British; and in general the wheat of warm climates he found abounded more in gluten and in insoluble parts, and of greater specific gravity, harder and more difficult to grind.

4644. *The uses of wheat* in the baking, culinary, and confectionary arts are well known. It is also used for making starch, by steeping the grain and then beating it in hempen bags. The mucilage is thus mixed with the water, produces the acetous fermentation, and the weak acid thus formed renders the mucilage white. After settling, the precipitate is repeatedly washed, and then moulded into square cakes, and kiln dried. In drying the cakes separate into flakes, as in the starch of the shops. Starch is soluble in hot water, but not in cold; and hence, when ground down, it makes an excellent hair-powder. Its constituents are; carbon, 43.55; oxygen, 49.68; and hydrogen, 6.77 = 100.

4645. *The uses of wheat-straw* are various, and well known: as fodder it is, according to Professor Thær, the most nourishing of any; and it makes the best thatch: it is generally preferred for litter, though rye and barley-straw are softer; it is used for making bee-hives, horse-collars, mattresses, huts, boxes, baskets, and all kinds of what is called Dunstable work; for the cider press, and, among other things, for burning; to procure potash from the ashes. The straw of wheat, from dry chalky lands, is manufactured into hats both for men and women. For this purpose, the middle part of the tube, above the last joint, is taken, and being cut into a length of eight or ten inches, is split in two. These splits are then plaited, by females and children, into various kinds of plait or ribbands, from half an inch to an inch broad: these, when sewed together according to fancy or fashion, form different descriptions of ladies' bonnets, and the commoner plait and coarser straw of mens' hats. The hats are whitened by being placed in the vapor of sulphur. Leghorn hats are made from the straw of a bearded variety of wheat, which some have confounded with rye. It is cultivated on the poorest sandy soils in the neighborhood of the Arno, between Leghorn and Florence, expressly for this manufacture. It is of humble growth, and not above eighteen inches high; is pulled up when green, and bleached white, by spreading and watering on the gravelly banks of the Arno. The straws are not split; but in other respects the manufacture into ribbands is the same as at Dunstable in England.

4646. *The diseases of wheat* are the rust, smut, or black mildew, the latter including what is vulgarly called blight. These have been already treated of in our view of the vegetable economy, and we shall merely offer a few practical observations on the smut and mildew. In whatever manner the smut may be transmitted from the seed pickle in the ground to the ear, it seems certain that, in general, the proximate cause of smut is the infection of the seed by the dust of the smut-ball (*Lycoperdon globosum*); and that, though the most careful washing, even with the application of caustics, may not, in every case, insure against smut; yet, if the seed be prepared in the way already mentioned, the disease will never prevail to such a degree as to effect materially the value of the crop. This is all that cultivators need to know, and all, perhaps, in the present state of science, that can be known, of the cause and prevention of smut.

4647. *Mildew* is a much more destructive distemper than smut, and, as it is probably occasioned by a peculiar state of the atmosphere during the periods of flowering and ripening, it is likely to baffle all attempts at prevention. The prevalence of heavy fogs, or mist, drizzling rains and sudden changes in the temperature, have been assigned as the causes of mildew; and as it has been found, that open airy exposures are much less affected than low sheltered lands, in years when mildew prevails most generally, the disorder may perhaps be somewhat diminished by drilling, which admits a freer circulation of air. Spring or summer wheat is less liable to mildew than the winter species, though it does not always escape. Minute parasitical fungi are commonly detected on the straw of mildewed wheat; and there cannot be the least doubt that the barberry bush and probably several other shrubs, on which these fungi abound, have a powerful influence in communicating the disease to a certain distance. (*Sir Joseph Banks on Mildew, and Com. to the B. of Agr. vol. vii.*)

4648. *The culture of summer wheat* differs from that of winter or spring-sown winter wheat, in its requiring a more minutely pulverised and rather richer soil. It need not

be sown sooner than April, and it advances so rapidly to maturity that it hardly affords time for hoeing (if sown in rows) or harrowing and rolling. When grass seeds or clover are sown on the same ground, they are sown immediately after the wheat, and harrowed in with a light harrow or rolled in. In this, and indeed, all other respects, the preparation of the soil and sowing of this grain is the same as for barley.

4649. *The produce of summer wheat*, both in grain and straw, is considerably less than that of winter wheat; the straw is only fit for litter or inferior fodder; the flour produced by the grain is rather coarser and darker than that of common wheat. Of course this sort of wheat cannot, as already observed, be recommended for general culture.

SECT. II. *Rye*.—*Secale Cereale*, L. *Trian. Dig. L.* and *Gramineæ*, J. *Siegle*, Fr.; *Rogon*, Ger.; and *Segale*, Ital. (*fig. 554.*)

4650. *Rye*, according to some, is a native of Crete; but it is very doubtful if it be found wild in any country. It has been cultivated from time immemorial, and is considered as coming nearer in its properties to wheat than any other grain. It is more common than wheat on most parts of the continent; being a more certain crop, and one which requires less culture and manure. It is the bread corn of Germany and Russia. In Britain it is now very little grown; being no longer a bread corn, and therefore of less value to the farmer than barley, oats, or pease.

4651. *The varieties of rye* are not above two, known as winter and spring rye; but there is so little difference between them, that spring rye sown along with winter rye can hardly be distinguished from it.

4652. *The soil for rye* may be inferior to that chosen for wheat: it will grow in dry sandy soils, and produce a tolerable crop, and on the whole it may be considered as preferring sands to clays. The preparation of the soil should be the same as for wheat. According to Professor Thaer, rye abstracts 30 parts in a hundred of the nutriment contained on the soil in which it is grown.

4653. *The climate for rye* may be colder than for wheat; but it is rather more injured by rains during winter; and equally injured as wheat by moist weather during the flowering season.

4654. *Rye is sown* either in autumn or spring, and either broad-cast or in drills: two bushels and a half is the usual allowance when it is sown broad-cast. As it vegetates more slowly than wheat, it should be sown when the soil is dry: a wet soil being apt to rot the grain before it has completely germinated. No pickling or other preparation is given.

4655. *The after culture, harvesting, and threshing* are the same as for wheat: and the produce in grain is, under similar circumstances, equal in bulk: but in straw it is greater in rye than in any other grain. Sir H. Davy found in 1000 parts of rye 61 parts of starch and 5 parts of gluten. Professor Thaer says, rye is the most nourishing grain next to wheat. It contains an aromatic substance, which appears to adhere more particularly to the husk; since the agreeable taste and smell peculiar to rye-bread is not found in that which is made from rye-flour that has passed through a very fine bolting-cloth; while the fragrance may be restored by a decoction of rye-bran in the warm water used to make the dough. This substance, Thaer says, seems to facilitate digestion, and has an action particularly refreshing and fortifying on the animal frame.

4656. *The use of rye* is chiefly for bread, especially for gingerbread. It is also used in the distilleries; and the straw is used for the same purposes as that of wheat, excepting that it is useless as fodder. Some prefer it for thatching and litter, and also for collar-making; it is also employed in Dunstable work. Tanners are said to use it in some districts.

4657. *Rye is sometimes sown as a green crop*, with a view of affording some keep for sheep early in the spring; and also for being ploughed in as manure; but that husbandry must be bad or unfortunate which requires recourse to either mode. In some districts it is customary to sow the head-lands of wheat-fields with rye, which is said to keep poultry from penetrating to the wheat.

4658. *Rye is subject to few diseases*, and is even sown among wheat and round wheat-fields, from an idea that it will keep off blight and mildew, as well as poultry.

SECT. III. *Barley*.—*Hordeum*, L. *Trian. Dig. L.* and *Gramineæ*, J. *L'Orge*, Fr.; *Gerste*, Ger.; and *Orzo*, Ital.; *Byg*, Dan. and Swed.

4659. *Barley*, though less calculated for a bread-corn than rye, may be considered as next in value to wheat in Britain. Of what country it is a native is unknown: some assign it to Tartary, others to Siberia, and even Scotland has been mentioned. It has been cultivated from the earliest antiquity, and was much in use among the Romans, both as food for soldiers and horses. In Sweden and Lapland it is more cultivated than any

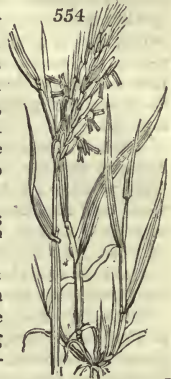



other grain, on account of its requiring to be so short a period in the soil; sometimes not longer than six weeks, and not often more than seven or seven and a half. In Spain and Sicily they have two crops a year on the same soil: one is sown in autumn and ripens in May, and the other is sown in May and reaped in autumn. In Britain, barley is a tender grain, and easily hurt in any of the stages of its growth, particularly at seed time; a heavy shower of rain will then almost ruin a crop on the best prepared land; and in all the after processes, greater pains and attention are required to insure success, than in the case of other grains. The harvest process is difficult, and often attended with danger; even the threshing of it is not easily executed with machines, because the corn generally adheres to the grain, and renders separation from the straw a troublesome task.

4660. *Species and varieties.* (fig. 555.) There are six species and subspecies of this grain in cultivation besides varieties. These are:

- |  |  |
|--|--|
| 1. <i>Hordeum vulgare</i> , Spring barley (a). | 4. <i>Hordeum distichon</i> , Common or long-eared barley (c). |
| 2. <i>coeleste</i> , Siberian barley.          | 5. <i>nudum</i> , Naked barley.                                |
| 3. <i>hexastichon</i> , Winter barley (b).     | 6. <i>zeocriton</i> , Sprat or battledore (d).                 |

The second and fifth sort are allowed to be subspecies or varieties of the first and fourth, and indeed there can be little doubt that the whole do not constitute more than one species.



4661. *The spring barley or early barley (a)*, is distinguished by its double row of beards or awns standing erect, and its thin husk which renders it favorable for malting. This is the sort principally cultivated in the southern and eastern districts of both England and Scotland, and of which the farmers make two sorts, viz. the common, and the rath-ripe barley: but these two sorts are in reality the same: for the rath-ripe is only an alteration of the common barley, occasioned by being long cultivated upon warm gravelly soils. The seed of this, when sown on cold or strong land, will, the first year, ripen near a fortnight earlier than the seed taken from strong land, and therefore the farmers in the vales generally purchase their seed-barley from the warm or gravelly lands; for, when preserved in the vales two or three years, it becomes full as late in ripening as the common barley of their own product: on the other hand, the farmers on warm lands are also obliged to procure their seed-barley from the strong lands, otherwise their grain would degenerate in bulk or fulness, which, by this change, is prevented.

4662. *The Siberian barley, Orge celeste, Fr. and Himmels gerste, Ger.*, is a variety of early barley with broader leaves and reckoned more productive than the other. It is much grown in the north of Europe, and was introduced to this country in 1768, but is believed to be now lost or merged in the parent species.

4663. *Winter barley, late barley, or square barley (b)*, has the grains disposed in four or in six rows, large and thick skinned. It is chiefly cultivated in the north of England and in Scotland, on account of its hardness; but from the thickness of its rind it is ill adapted for malting, and is growing out of use.

4664. *Bigg, byg, or barley big*, is a variety of winter barley known by always having six rows of grains, by the grains being smaller and the rind thicker, and by its being earlier than the parent variety. Professor Martyn says, he has frequently counted forty-two grains on one ear of bigg, when common or long-eared barley had only twenty-two.

4665. *Common or long-eared barley (c)*, is known by its very long spike or ear, flattened transversely, greater in breadth than thickness, with chaff ending in an awn sixteen times the length of the grain. This sort is cultivated in many parts of England and Scotland; though some object to it because the ears being long and heavy they think it apt to lodge.

4666. *Naked barley, or wheat barley*, is known by the grain separating easily from the chaff, and is by some considered as nothing else than spelt wheat, which it greatly resembles. It does not appear to be cultivated at present in any part of Britain.

4667. *Sprat, or battledore barley (d)*, is known by its low stature, coarse straw, short broad ears, and long awns. The long awns and closeness of the ears protect it better from birds than most other sorts, but as the straw is scanty and of little use it is not much cultivated.

4668. Besides these sorts there are some *local varieties*, as Thanet barley, Putney barley, &c. which are merely names given to the varieties common in those places. The Thanet is the winter, and the Putney the sprat barley.

4669. *New varieties* may be procured by selection or crossing, as in the case of wheat. (4607.)

4670. In choosing a sort of barley for cultivation, regard must be had to the soil and climate. The hardiest may be considered the winter barley, and the earliest, and perhaps the best, is the spring barley. The long-eared is also a much esteemed variety. In choosing from any particular variety, the best grain for sowing is that which is free from blackness at the tail, and is of a pale lively yellow color, intermixed with a bright whitish cast; and if the rind be a little shrivelled, it is so much the better, as it shows that it has

sweated in the mow, and is a sure indication that its coat is thin. The husk of thick rinded barley being too stiff to shrink, will lie smooth and hollow, even when the inside furrow has shrunk from it. The necessity of a change of seed from time to time, by sowing that of the growth of a different soil, as has been observed, is in no instance more evident than in the culture of this grain, which otherwise becomes coarser and coarser every year. But in this, as well as in all other grain, the utmost care should be taken that the seed be full bodied.

4671. *The best soil for barley* is a light rich loam, finely pulverised. It will neither grow well on a sandy or soft soil, nor on strong clays, such as are suitable for wheat.

4672. *The preparation of the soil* is sometimes by a naked fallow, but generally by a turnip fallow: sometimes it is taken after pease and beans, but rarely by good farmers, either after wheat or oats, unless under special circumstances. When sown after turnips, it is generally taken with one furrow, which is given as fast as the turnips are consumed, the ground thus receiving much benefit from spring frosts. But often two or more furrows are necessary for the fields last consumed; because, when a spring drought sets in, the surface, from being poached by the removal or consumption of the crop, gets so hardened as to render a greater quantity of ploughing, harrowing, and rolling necessary, than would otherwise be called for. When sown after beans and pease, one winter and one spring ploughing are usually bestowed; but, when after wheat or oats, three ploughings are necessary, so that the ground may be put in proper condition. These operations are very ticklish in a wet and backward season, and rarely in that case is the grower paid for the expense of his labor. Where land is in such a situation as to require three ploughings before it can be seeded with barley, it is better to summer fallow it at once, than to run the risks which seldom fail to accompany a quantity of spring labor. If the weather be dry, moisture is lost during the different processes, and an imperfect germination necessarily follows: if it be wet, the benefit of ploughing is lost, and all the evils of a wet seed-time are sustained by the future crop. (*Brown.*)

4673. *To whatever crop barley succeeds*, the harrow and roller, when the plough alone is insufficient, should be employed in reducing the soil to a considerable degree of fineness. In most cases more than one earth is given; though, after a winter furrow, the grubber may be used in spring instead of the plough. After turnips, eaten on the ground by sheep, the land, being consolidated by their treading, sometimes receives two ploughings; but if only one, it should be well harrowed and rolled; and it is often finished by harrowing after the roller, especially if grass-seeds be sown, which are covered by this last harrowing. Barley is sometimes sown on the first ploughing, and covered by a second shallow ploughing. As it is found of great importance, with a view to speedy and equal vegetation, that the ground should be fresh and moist, barley is generally sown upon what is termed *hot-fur*, that is, as soon as possible after it is turned up by the plough.

4674. *Manure* can seldom be given with advantage to a crop that occupies the soil so short a period as barley, and therefore it generally is sown on land which has been enriched for a preceding crop.

4675. *The climate* in which barley delights is warm and dry. There are instances of a crop being sown and ripened without having enjoyed a single shower of rain; but gentle showers from the time it is sown till it begins to shoot into the ear, are favorable; while heavy rains at any period, and especially immediately after sowing, or during the blossoming, ripening, and reaping season, are highly injurious.

4676. *The best season for sowing barley* is considered to be from the beginning of April to the middle of May; but *bigg* may be sown either in autumn to stand the winter, or as late as the first week of June. In England, the winter or four-rowed barley is frequently sown in autumn, and stands the most severe winters. With respect to the lateness at which *bigg* and summer barley may be sown, much depends on the sort of weather which occurs during the first three weeks after sowing. When barley is sown late it is sometimes steeped in common water to promote its germination; but it is seldom pickled or otherwise prepared. The advantages of steeping are procuring an equal germination, and consequently ripening and getting the start of weeds. The following directions are given for performing the operation. First, take out about one-third of the contents of the sacks of seed barley or bear to allow for the swelling of the grain; lay the sacks with the grain to steep in clean water; let it be covered with it for at least twenty-four hours; when the ground is very dry, and no likelihood of rain for ten days, it is better to lie thirty-six hours; sow the grain wet from steeping without any addition: the seed will scatter well as clean water has no tenacity; only the sower must put in a fourth or a third more seed in bulk than is usual of dry grain, as the grain is swelled in that proportion; harrow it in as quickly as possible after it is sown; and though not necessary, give it the benefit of a fresh furrow if convenient. You may expect it up in a fortnight at farthest. (*Brown.*)

4677. *The quantity of seed* is different in different cases, according to the quality of the soil and other circumstances. Upon very rich lands, eight pecks per acre are sometimes sown; twelve is very common; and upon poor land, more is sometimes given. Among the best farmers, it seems a disputed point whether the practice of giving so small a quantity of seed to the best lands is advantageous. That there is a saving of grain there can be no

doubt; and that the bulk may be as great as if more seed had been sown, there can be as little question. Little argument, however, is necessary to prove that thin sowing of barley must be attended with considerable disadvantage; for if the early part of the season be dry, the plants will not only be stunted in their growth, but will not send out offsets; and, if rain afterwards fall, an occurrence that must take place some time during the summer, often at a later period of it the plants begin to stool, and send out a number of young shoots. These young shoots, unless under very favorable circumstances, cannot be expected to arrive at maturity; or if their ripening is waited for, there will be a great risk of losing the early part of the crop, a circumstance that frequently happens. In almost every instance an unequal sample is produced, and the grain is for the most part of an inferior quality. By good judges, it is thought preferable to sow a quantity of seed sufficient to ensure a full crop, without depending on its sending out offsets; indeed, where that is done, few offsets are produced, the crop grows and ripens equally, and the grain is uniformly good. (*Brown on Rural Affairs.*)

4678. *The modes of sowing barley* are either broad-cast or in rows by the drill or ribbing. The broad-cast mode is almost universally adopted; unless in lands much infested with annual weeds, where drilling and horse-hoeing may be employed with advantage.

4679. The only *culture* which barley requires while in a growing state, is hoeing and weeding if in rows, and weeding alone if broad-cast. Sometimes barley is rolled to compress a soft soil and exclude the drought, and when very thick it may be first harrowed and then rolled. Grass seeds and clover are sown with the grain before the last harrowing, when the broad-cast mode is adopted; and immediately before hoeing, when the barley is in rows. The former is much the best mode for insuring a strong plant of clover.

4680. *Eating down barley*, which from winter or very early sowing is over luxuriant, is practised in some districts, but it is alleged that mowing is much better than feeding it; because the scythe takes off only the rank tops, but the sheep feed upon all indifferently; nor should they even, in any case, be left upon it too long, because, being particularly fond of the sweet end of the stalk next the root, they bite so close as to injure the future growth of the plant.

4681. *Barley is ripe* when the red roan, as the farmers term it, meaning a reddish color on the ear, is gone off, or when the ears droop, and fall, as it were, double against the straw, and the stalks have lost their verdure.

4682. *In the harvesting of barley* more care is requisite than in taking any of the other white crops, even in the best of seasons; and in bad years it is often found very difficult to save it. It is known to be ripe by the ears drooping and falling, as it were, doubly against the straw. Owing to the brittleness of the straw, after it has reached a certain period it must be cut down; as, when it is suffered to stand longer, much loss is sustained by the breaking of the heads. On that account it is cut at a time when the grain is soft, and the straw retains a great proportion of its natural juices, consequently requires a long time in the field before either the grain is hardened, or the straw sufficiently dry. When put into the stack sooner it is apt to heat, and much loss is frequently sustained. Barley is generally cut down in England with the cradle scythe, and either tied up or carted home loose after lying in the swath some days to dry. It is not apt to shed; but in wet weather it will be apt to spout or grow musty; and therefore every fair day after rain it should be shook up and turned; and when it is tolerably dry, let it be made up into shocks; but be careful never to house it till thoroughly dry, lest it mow-burn, which will make it malt worse than if it had spired in the field. It is remarked by Lisle, that poor thin barley should be cut a little sooner than if the same plants were strong and vigorous; as the straw, when the plants are full ripe, in such cases will not stand against the scythe. In this situation, barley in particular should lie in swarth till it is thoroughly dry. Some of his barley, which lay out in swarth five or six days in very fine weather, though both blighted and edge-grown, grew plump, and acquired very near as good a color as the best. He reckons short scythes the best for mowing lodged or crumpled corn, because they miss the fewest plants; and observes, that a bow upon the scythe, which carries away the swarth before it, is preferable to a cradle, the fingers of which would be pulled to pieces by the entangled corn, in drawing back the scythe. In Scotland and Ireland it is generally reaped with the sickle, bound in sheaves and set up in shocks.

4683. *In stacking barley* many farmers make an opening in the stack, from top to bottom. This opening is generally made by placing a large bundle of straw in the centre of the stack, when the building commences, and in proportion as it rises, the straw is drawn upwards, leaving a hollow behind; which if one or two openings are left in the side of the stack near the bottom, insures so complete a circulation of air, as not only to prevent heating, but to preserve the grain from becoming musty.

4684. *The threshing and dressing of barley* requires more labor than any other grain, on account of the difficulty of separating the awns from the ears. For this purpose some

threshing machines are furnished with what is called a hummelling machine, already described (2649.); and where this is wanting, it is customary to put the grain, accompanied with a portion of threshed straw, a second time through the machine. Where barley has been mown, the whole of the straw requires to be twice threshed, independently of the necessity of getting rid of the ears.

4685. *The produce of barley*, taking the average of England and the south of Scotland, Donaldson considers, might be rated at thirty-two bushels; but when Wales and the north of Scotland are included, where, owing to the imperfect modes of culture still practised, the crops are very indifferent, the general average over the whole will not probably exceed twenty-eight bushels the acre. Middleton states it as varying in England from fifteen to seventy-five bushels per acre. The average produce of the county of Middlesex, he says, is about four quarters of corn and two loads of straw per acre.

4686. *The uses of barley* are various. In Wales, Westmorland, Cumberland, and in the north, as well as in several parts of the west of Scotland, the bread used by the great body of the inhabitants is made chiefly from barley. Large quantities of the barley cultivated in England are converted into beer, ale, porter, and what is called British spirits, as English gin, English brandy, &c. The remainder, beyond what is necessary for seed, is made into meal, and partly consumed in bread by the inhabitants of the above-mentioned districts, and partly employed for the purpose of fattening black-cattle, hogs, and poultry. There is a much greater share of the Scotch barley consumed in distillation, in proportion to the quantity cultivated, than there is in England. Exclusive of what is used for seed, the Scotch barley is either converted into beer or ale; or made into pot-barley, or into meal, for the use of the inhabitants in the more remote and less cultivated parts of the kingdom; or, lastly, into whisky. In *The Report of Middlesex* it is stated, that much of the most ordinary barley is given to poultry: the rest is sold to the maltsters, except so much as is reserved for seed.

4687. *But malt is the great purpose to which barley is applied in Britain.* To understand the process of malting, it may be necessary to observe that the cotyledons of a seed, before a young plant is produced, are changed by the heat and moisture of the earth into sugar and mucilage. Malting grain is only an artificial mode of effecting this by steeping the grain in water and fermenting it in heaps, and the arresting its progress towards forming a plant by kiln-drying, in order to take advantage of the sugar in distillation for spirit or fermentation for beer. The grain of barley contains starch and sugar; and the chemical constituents of both these ingredients are very nearly alike. In the process of malting, a portion of the starch is converted into sugar, so that the total quantity of sugar, and consequently the source of spirit, is increased by the transformation.

4688. *To choose a proper sample of barley for malting*, observe the directions given for choosing seed barley. (4670.)

4689. *Of pot-barley* there are two sorts, pearl and Scotch; both are produced by grinding off the husk, and the pearly barley is produced by carrying the operation so far as to produce roundness in the kernel. It is used in soups, gruels, and medicinal drinks.

4690. *Barley meal* is ground like oatmeal or flour; the coarser sort, with the bran, is used for fattening live stock, especially pigs and poultry, but fine bolted barley flour, made into a thin pottage or pudding, and spread out in thick cakes, and toasted on a hot-plate of metal, forms a light breakfast bread, much esteemed in some parts of Scotland. It is served in a recent state, hot, and spread with butter and honey, and eaten in several folds. Two parts of barley flour, one of wheat flour, and one of rye, are said to make a light and very agreeable loaf bread.

4691. *The produce of barley in flour* is 12lbs. to 14lbs. of grain. Sir H. Davy found 1000 parts of barley meal to afford 920 parts of soluble or nutritious matter, viz. 790 of mucilage or starch, 70 of sugar, and 60 of gluten.

4692. *Barley straw* is chiefly used for litter and packing; it is unfit for thatch or rope making, and of little value as fodder.

4693. *The diseases of barley* are few, and chiefly smut, which it is found cannot be prevented by pickling and liming.

SECT. IV. *The Oat.*—*Avena Sativa*, L. *Trian. Dig. L.* and *Gramineæ*, J. *L' Avoine*, Fr.; *Haber*, Ger.; and *Vena*, Ital.

4694. *The oat* is a very useful grain, and more peculiarly adapted for northern climates than either wheat, rye, or barley. Its native country is unknown, unless the wild oat be considered as the parent species, which is highly probable. The culture of the oat is chiefly confined to latitudes north of Paris. It is scarcely known in the south of France, Spain, or Italy; and in tropical countries, its culture is not attended to. In Britain it has long been very generally cultivated, formerly as a bread corn, but now chiefly as horse food. Of all the grain this is the easiest of culture, growing in any soil that admits of ploughing and harrowing.

4695. *The varieties of oats are more numerous than of the other grains, and some of them very distinctly marked. The principal are as follow :*

4696. *The white oat or common oat (fig. 556 a) in most general cultivation both in England and Scotland, and known by its white husk and kernel.*

4697. *The black oat, known by its black husk ; cultivated on poor soils, in the north of England.*

4698. *The red oat, known by its brownish red husk, thinner and more flexible stem, and firmly attached grains. It is early, suffers little from winds, meals well, and suits windy situations and late climates. It is understood to have been originated in Peebleshire, on the estate of Magbie-hill, by which name it is sometimes known.*

4699. *The Poland oat, known by its thick white husk, awnless chaff, solitary grains, short white kernel, and short stiff straw. It requires a dry warm soil, but is very prolific.*

4700. *The Friezland or Dutch oat, has plump thin-skinned grains, mostly double, and the large one sometimes awned. It has longer straw than the Poland, but in other respects resembles it.*

4701. *The potatoe oat has large, plump, rather thick-skinned grains, double and treble, with longer straw than either of the two last sorts. It is almost the only oat now raised on land in a good state of cultivation in the north of England and south of Scotland, and usually brings a higher price in the London market than any other variety. It was discovered growing in a field of potatoes in Cumberland, in 1788, and from the produce of the single stalk which there sprung up by accident, probably from the manure, has been produced the stock now in general cultivation.*

4702. *The Siberian or Tatarian oat (b), is considered by some as a distinct species. The grains are thin and small, and turned mostly to one side of the panicle, and the straw is coarse and reedy. It is little cultivated.*

4703. *There are various other varieties, as Church's oat, the Angus oat, the dun oat, &c., but they are either too local or obsolete to require particular notice. In the oat, as in other plants extensively cultivated, new varieties will always be taking place of old ones.*

4704. *To procure new varieties adopt the mode by selection, by which, as appears above, the potatoe and red oat were brought forward ; or proceed systematically by cross impregnation, as directed for raising new varieties of wheat. Degeneracy, Brown observes, has taken place to a certain extent in the potatoe oat ; but it is presumed that the consequences might be removed with ease, were first principles returned to. To make a selection of the strongest ears, which carried the purest grain, is not a difficult business ; and were this selection attended to by half a dozen farmers in a district, it is obvious, that the breed, or variety, might be preserved pure and uncontaminated. If slovenly farmers were not provided with good seed, it would be their own fault, since, if they would not take the trouble to select and breed for their own use, they might always be provided by those who were either better qualified for making the selection, or were more attentive to the interests of agriculture. (Brown.)*

4705. *In choosing a sort from among the varieties described, the potatoe and Poland, are the best for lowlands, and the red oat for uplands, and late climates in a state of good cultivation. For inferior soils the white or common oat, and for the poorest of all the black oat may be adopted.*

4706. *The soil for oats may be any kind whatever, from the stiffest clays to moss or bog, provided it be laid sufficiently dry. The most tenacious clays, and meagre gravels and sands, where scarcely any useful seed-bearing plant, excepting buck-wheat, could be grown, will produce a crop of oats if ploughed at a proper season, and the seed judiciously sown and covered.*

4707. *The preparation of the soil for oats is less than for any other grain. It is almost always the first crop on newly-broke up lands ; and as it prospers best on a soil not too finely pulverised, it is commonly sown on one earth. In regular rotations, oats are chiefly sown after grass ; sometimes upon land not rich enough for wheat, that had been previously summer-fallowed, or had carried turnips ; often after barley, and rarely after wheat, unless cross-cropping, from particular circumstances, becomes a necessary evil. One ploughing is generally given to the grass-lands, usually in the month of January, so that the benefit of frost may be gained, and the land sufficiently mellowed for receiving the harrow. In some cases, a spring furrow is given when oats succeed wheat or barley, especially when grass-seeds are to accompany the crop. The best oats, both in quantity and quality, are always those which succeed grass ; indeed, no kind of grain seems better qualified by nature for foraging upon grass-land than oats ; as a full crop is usually obtained in the first instance, and the land left in good order for succeeding ones. (Tr. on Rural Affairs.)*

4708. *The climate for oats should be cool and moist ; when dry and warm, the panicles are so dried and contracted, that they cease to convey sufficient nourishment to the ears, which thus never become plump, but thick husked, long awned, and unproductive in meal. This is very often the case with the oats in Scotland in a very dry year, and very common in the south of England most years.*

556



4709. *The season of sowing oats* is from the last week in February to the end of April. About the middle of March is preferred by the best farmers. No preparation is ever given to the seed; but it should be plump, fresh, and free from the seeds of weeds. Oats sown in autumn are generally killed during winter, the plant being in this respect more tender than wheat, rye, or barley bigg.

4710. *The quantity of seed*, where oats are sown broad-cast, is usually from four to six bushels to the acre. Land sown with potatoe oats requires less seed, in point of measure, than when any of the other sorts are used; first, because this variety tillers better than any other, and next, because having no awn, a greater number of grains are contained in a bushel.

4711. *The mode of sowing oats* is almost universally broad-cast; but where they are sown after turnips, or on other well pulverised soils, some adopt the row culture.

4712. *The after-culture* depends on the mode of sowing, but seldom consists of more than weeding before the flower-stalks begin to shoot up.

4713. *In harvesting oats* in England, they are generally cut down with the scythe and carried loose to the barn or stack; but in the northern districts, and where threshing machines are used, they are tied into sheaves if mown, but, for the most part, reaped with the sickle, in order in both cases to facilitate the process of threshing. Oats are ready for the scythe or sickle when the grain becomes hard, and the straw yellowish. They should generally be cut before they are dead ripe, to prevent the shedding of the grain, and to increase the value of the straw as fodder. They rarely get much damage when under the harvest process, except from high winds, or from shedding, when opened out after being thoroughly wetted. The early varieties are much more liable to these losses than the late ones; because the grain parts more easily from the straw, an evil to which the best of grain is at all times subject. Early oats, however, may be cut a little quick, which, to a certain extent, lessens the danger to which they are exposed from high winds; and if the sheaves be made small, the danger from shedding after rains is considerably lessened, because they are thus sooner ready for the stack. Under every management, however, a greater quantity of early oats will be lost during the harvest process than of the late ones, because the latter adhere firmly to the straw, and consequently do not drop so easily as the former. (*Brown.*) In harvesting oats in wet seasons, the practice of gaiting the sheaves (2940.) is generally adopted. In Sweden, in most seasons, the oat crop is dried on frames or poles (683.), and in Russia, not only oats, but barley and rye are kiln-dried in the straw.

4714. *Kiln-drying oats and other corns in the straw* has been found necessary, and is very generally practised through the north of Russia, Livonia, Courland, and Lithuania, being the last operation of harvest for preserving all kinds of corns, pease, beans, and buck-wheat. They are dried in the fields as much as can be; but, when brought home, they are kiln-dried, and are then ready to be either threshed out immediately, or put up in barns, without any danger of either corn or straw becoming musty or rotting. The common practice of the boors is, during winter, to thresh out by degrees, as in this country, their oats and barley, in order to have straw fresh for their cattle, such straw being their only provender. The process of kiln-drying by no means prevents the germination of the grain when used for seed, while it not only preserves the grain and straw, but improves their taste and salubrity. It enables Russia to export large quantities of rye and wheat with less risk of damage to the grain, than is incurred by other nations of the north of Europe.

4715. *The kiln* (fig. 557.) in general and established use throughout Russia, for the purpose of drying corn in the straw, is heated commonly by fires of wood. It is a simple and cheaply-erected structure, the walls eight feet high, and fifteen feet square within: At this height there are two strong cross beams (*a*), to support the small timbers, laid over them as ribs. The corn stands in sheaves above these ribs (*b*), closely set up, the band ends of the sheaves down, and the corn or grain ends up: the walls then rise above the ribs about five or six feet more, the kiln being closed by a simple ceiling of cross joists at this height, covered with thin turf. Any cheap and ordinary roof answers to cover the whole. The fire-place is constructed so as to throw back the ascending spark; a small porch (*c*), directly opposite to the fire-place, prevents violent blasts of wind, and covers from rain the fuel and the attendant. About 300 sheaves (twenty-five stooks) of corn are dried at one time. It is put on in the evening, and left on the kiln through the night, after the wood has been burned into charcoal, and the door above the fire-place closed. At one end of the kiln there is frequently an open shed or barn (*d*), for convenience in bringing corn to, or taking it from the kiln.

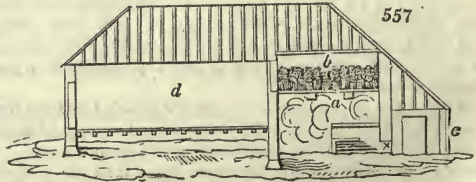

4716. *The produce of oats* is generally considered greater and of better quality in the northern than in the southern counties; and the reasons are obviously that, in the latter, more attention is paid to their culture, and the climate is more favorable for the maturation of the grain. Ten quarters an acre is reckoned a good crop in the north, but the produce is often twelve and thirteen quarters, and the straw from two to three and a half loads per acre.

4717. *The produce of oats in meal* is 8 lbs. for 14 lbs. of corn. Sir H. Davy found 100 parts of oats afford 59 parts of starch, six of gluten, and two of saccharine matter:

4718. *The use of oats in the north, in Ireland, and in some parts of Yorkshire and Derbyshire, is partly for meal and partly for horse food. In the south it is almost entirely for horse-food, poultry, and groats for gruel. It is occasionally malted and used in distillation. The fine powder which is produced by husking the corn, or making grist, forms the sowens of the Scotch (the flumerty of the Irish) an agreeable light and wholesome supper dish.*

4719. *The diseases of the oat are few. Sometimes it is found attacked by the smut; but the more common injury sustained by oats is from wire-worm, or larva of insects which generally abound in lands newly broken up from turf. One of the most certain practices of avoiding these is, by not ploughing the ground, especially if old turf, till immediately before sowing. By this means the insect is turned down, and before it can work its way to the surface (if ever it does), the corn is beyond its reach. In this way gardeners destroy and retard the progress of the gooseberry caterpillar by digging under the bushes, for it is found that the eggs and larvæ of insects, like seeds and bulbs, when buried too deep in the ground, have their progress retarded, or their vital principle destroyed. (Encyc. of Gard. 4663.)*

SECT. V. *Cereal Grasses cultivated in Europe, some of which might be tried in Britain.*

4720. *The cereal grasses which the climate of Britain does not readily admit of cultivating, are the millet, maize, and rice.*

4721. *Of the millet there are three distinct genera, the Polish millet (Digitaria), cultivated in Poland; the common millet (Panicum), or panic grass, cultivated in Germany, and sometimes in this country; and the great or Indian millet (Holcus), cultivated in India, Italy, and America.*

4722. *Of the common millet there are three species, the Panicum Germanicum (fig. 558 a), a native of the south of Europe; the P. miliaceum (b), a native of the East Indies; and the P. Italicum (c), also of Indian origin.*

4723. *The common or German millet (Panicum Germanicum, a), rises with a jointed reed-like stalk, about three feet high, and about the size of the common reed, with a leaf at each joint a foot and a half long, and about an inch broad at the base where broadest, ending in an acute point, rough to the touch, embracing the stalk at the base, and turning downwards about half the length. The stalks are terminated by compact spikes, about the thickness of a man's finger at bottom, growing taper towards the top, eight or nine inches long, closely set with small roundish grain. It is annual, and perishes soon after the seeds are ripe. There are three varieties of it, with yellow, white, and purple grains. It has been formerly cultivated for bread in some of the northern countries.*

4724. *The cultivated millet (Panicum miliaceum, b), rises with a reed-like channelled stalk, from three to four feet high; at every joint there is one reed-like leaf, joined on the top of the sheath, which embraces and covers that joint of the stalk below the leaf, and is clothed with soft hairs; the leaf has none, but has several small longitudinal furrows running parallel to the midrib. The stalk is terminated by a large loose panicle hanging on one side. Of this species there are two varieties, the brown and yellow;*

*the latter of which was formerly in cultivation, and is now sometimes sown for feeding poultry, and as a substitute for rice.*

4725. *The Italian millet (Panicum Italicum, c), rises with a reed-like stalk, near four feet high, and much thicker than that of the preceding; the leaves are also broader. The spikes are a foot long, and twice the thickness of those of the common millet, but not so compact, being composed of several roundish clustered spikes; the grain is also larger. There are two or three varieties of this, differing only in the color of the grain. It is frequently cultivated in Italy (whence its trivial name), and other warm countries. It is a native of both Indies, and of Cochin China.*

4726. *The Polish millet, or manna grass of the Germans (Digitaria sanguinalis, formerly Panicum sanguinale, fig. 559), is a low decumbent annual plant, seldom rising above nine inches or a foot high, with hairy leaves and slender panicles. It tillers much, and forms a close tuft, spreading and rooting at the joints. It is a native of England but not common, but grows in abundance in Poland, and is sometimes cultivated; the seeds being used like those of the other millets as a substitute for rice or sago.*

4727. *The great or Indian millet (Holcus sorghum, L. Sorghum vulgare, W. en. fig. 560. Honque sorgo, Fr.; Sorgsamem, Ger.; Sagina, Ital.; and Melœa, Span.), has a stem which rises five or six feet high, is strong, reedy, and like those of the maize, but smaller. The leaves are long and broad, having a deep furrow through, the centre;*



where the mid rib is depressed in the upper surface, and is very prominent below. The leaves are two feet and a half long, and two inches broad in the middle, embracing the stalks with their base. The flowers come out in large panicles at the top of the stalks, resembling at first appearance the male spikes of the Turkey wheat; these are succeeded by large roundish seeds, which are wrapped round with the chaff. This grain is a native of India, where it is much used to feed poultry, and is frequently sent to Europe for the same purpose. It is much cultivated in Arabia, and most parts of Asia Minor; and has been introduced into Italy, Spain, Switzerland, and some parts of Germany, also into China, Cochín China, and the West Indies, where it grows commonly five or six feet high, or more, and being esteemed a hearty food for laborers, is called negro guinea corn. Its long awns or bristles defend it from the birds. In England, the autumns are seldom dry and warm enough to ripen the seed well in the field. In Arabia it is called *dora* or *durra*; the flour is very white, and they make good bread of it, or rather cakes, about two inches in thickness. The bread which they make of it in some parts of Italy is dark and coarse. In Tuscany it is used chiefly for feeding poultry and pigeons, sometimes for swine, kine, and horses. Cæsalpinus says, that cattle fed on the green herb are apt to swell and die, but thrive on it when dried. They make brushes and brooms of its stalks in Italy, which are sent to this country, which Ray observed in the shops at Venice. Of this species there are two distinct varieties, known by their black and red husked seeds, besides subvarieties.

4728. *The only sorts of millet which can be cultivated with success in this country, are the German, cultivated, and the Polish sorts.* According to Professor Thær, the cultivated is to be preferred, as having the largest grain.

4729. *The soil for the millet should be warm, sandy, rich, and well pulverised to a good depth.* The seed is sown in May, very thin, and not deeply covered. In the course of its growth, no plant, Professor Thær observes, is more improved by stirring the soil, after which it grows astonishingly fast, and smother all weeds.

4730. *In harvesting the millet, great care is requisite not to shed the seed; and as it ripens rather unequally it would be an advantage to cut off the spikes as they ripen, as is done in reaping maize.* No grain is easier to thresh, or to free from its husk by the mill. It is used instead of rice, and in Germany bears about the same price. It produces a great bulk of straw, which is much esteemed as fodder.

4731. *The great Indian millet will grow in this country to the height of five or six feet, but will not ripen its seeds or even flower if the season is not dry and warm.* If its culture is attempted, it should be raised in a hot bed and transplanted.

4732. *The Zizania aquatica (fig. 561.) might be cultivated on the margin of ponds for its seeds, which much resemble those of Polish millet.* It is exceedingly prolific, grows in great luxuriance and produces abundance of bland farinaceous seeds, in all the shallow streams of the dreary wilderness in north-west America, between the Canadian lakes and the hilly range which divides Canada from the country on the Northern Pacific ocean. Its seeds contribute essentially to the support of the wandering tribes of Indians, and feed immense flocks of wild swans, geese, and other water-fowl, which resort there for the purpose of breeding. Productive as is this excellent plant, and habituated to an ungenial climate, and to situations which refuse all culture, it is surprising, says Pinkerton (*Geog.* vol. iii. 330.), that the European settlers in the more northern parts of America, have as yet taken no pains to cultivate and improve a vegetable production, which seems intended by nature to become, at some future period,

the bread-corn of the north.

4733. *The festuca fluitans resembles the zizania, and the seeds are used in Germany like those of Polish millet.* Various species of panicum, hordeum, and bromus, afford tolerable supplies of edible seeds.

4734. *The maize or Indian corn (Zea mays, fig. 192.) may be cultivated in this country in very dry warm situations, especially if the dwarf red-grained variety be adopted.* The straw forms an excellent fodder, and the grain as a bread-corn is much liked by some, but though it abounds in mucilage it contains little or no gluten, and is not likely to be much used by those who can procure wheaten or even rye bread.

4735. *The rice (Oriza sativa, fig. 562.) has been tried in this country, and if sown very early, would probably ripen its seeds.* The hill variety, which does not require watering, would probably succeed best. But there is no inducement to cultivate this and other grains or seeds when they can be imported at so low a rate. We merely introduce them to record the resources of British agriculture in case of necessity.

4736. *The buck-wheat (Fagopyrum) is vulgarly considered as a grain; and the canary grass (Phalaris) is a gramin cultivated for its seed; but neither being bread-corn grasses, we have classed them among manufactorial plants. (Chap. VIII. Sect. IV.)*





CHAP. III.

Of the Culture of Leguminous Field-Plants.

4737. The seed of the cultivated legumes are considered to be the most nutritive of vegetable substances grown in temperate climates. They contain a large proportion of matter analogous to animal substances, having when dry the appearance of glue, and equally nourishing as gluten. To the healthy workman this substance supplies the place of animal food ; and Von Thaer states, that in Germany neither sailors nor land laborers are content, unless they receive a meal of legumes at least twice a week. The straw or haulm, he says, cut before it is dead ripe is more nourishing than that of any of the cereal grasses. But leguminous plants are not only more than all others nourishing to man and animals, but even to vegetables they may be said to supply food ; since they are not only known to be less exhausting to the soil than most other plants, but some of them, and more especially the lupin, have been ploughed in green as manure from the earliest times. Many scientific agriculturists consider a luxuriant crop of pease or tares as nourishing the soil by stagnating carbonic acid gas on its surface ; which corresponds with the universal opinion of their being equal to a fallow, and with the value set on them in rotation, as already explained (4563). The legumes cultivated in British farming are the pea, bean, tare, and vetch, to which might be added the lentil, kidneybean, and chick pea.

4738. The nutritive products of these plants is thus given by Sir H. Davy, Einhoff, and Thaer :

Systematic name.	The quantity analysed, of each sort 1000 parts.	Whole quantity of soluble or nutritive matter.	Mucilage or starch.	Saccharine matter or sugar.	Gluten or albumen	Extract, or matter rendered insoluble during evaporation.
<i>Pisum sativum</i> - - -	Dry pease - - -	574	501	22	35	16
<i>Vicia faba</i> - - -	Common bean - - -	570	426	—	103	41
<i>sativa</i> - - -	Tares - - -	65	36	—	29	—
<i>Ervum lens</i> - - -	Lentils - - -	71	39	—	32	—
<i>Phaseolus vulgaris</i> - -	Kidneybean - - -	89	67	—	22	—

SECT. I. The Pea.—*Pisum sativum*, L. *Diadel. Decan.* L. and *Leguminosææ*, J. *Les Pois*, Fr. ; *Erbse*, Ger. and *Piscello*, Ital. (fig. 563.)

4739. The pea is the most esteemed legume in field cultivation both for its seed and haulm. It is supposed to be a native of the south of Europe, and was cultivated by the Greeks and Romans, and in this country from time immemorial, though its culture appears to have diminished since the more general introduction of herbage plants and roots ; and excepting near large towns for gathering green, and in a few places for boiling the pea, has given way to the bean or to a mixture of pease and beans. There are various inducements, however, to the cultivation of pease in dry warm soils near large towns. When the crop is good and gathered green, few pay better : the payment is always in cash, and comes into the pocket of the farmer in time to meet the exigencies of the hay, and sometimes even of the corn harvest. The ground after the pease have been removed is readily prepared for turnips, which also pay well as a retail crop near towns ; and the haulm is good fodder.

4740. The varieties of the pea are numerous ; but they may be divided into two classes ; those grown for the ripened seed, and those grown for gathering in a green state. The culture of the latter is chiefly near large towns, and may be considered as in part belonging to gardening rather than agriculture.

4741. The grey varieties are, the early grey, the late grey, and the purple grey ; to which some add the Marlborough grey, and horn grey.

4742. The white varieties grown in fields are the pearl, early charlton, golden hotspur, the common white or Suffolk, and other Suffolk varieties.

4743. New varieties of the pea are readily procured by selection or impregnation, of which a striking example given by Knight has been already referred to. (1599.)

4744. In the choice of sorts, where it is desired to grow grey pease for the sake of the seeds or corn, the early variety is to be preferred in late situations, and the late variety in



early ones ; but when it is intended to grow them chiefly for covering the ground and for the haulm, then the late varieties claim the preference, and especially the purple grey. Of white pease, to be grown for gathering green, the Charlton is the earliest, and the pearl or common Suffolk the most prolific. When white pease are grown for boilers, that is for splitting, the pearl and Suffolk are also the best sorts. It is supposed by some to be of considerable importance in the economy of a farm, when the nature of the soil is suitable, to have recourse to the early sorts ; as by such means the crops may in many cases be cut and secured while there is leisure, before the commencement of the wheat harvest. And that where the nature of the soil is dry and warm, and the pea crop of a sufficiently forward kind, it may be easy to obtain a crop of turnips from the same land in the same year, as has been suggested above. But in this view it is the best practice to put the crops in in the row method, and keep them perfectly clean by means of attentive hand and horse hoeing ; as in that way the land will be in such a state of preparation for the turnips, as only to require a slight ploughing, which may be done as fast as the pea crop is removed, and the turnip seed drilled in as quickly as possible upon the newly turned up earth. In some particular districts a third crop is even put into the same land, the turnips being sold off in the autumn and replaced by coleworts, for the purpose of greens in the following spring. This, according to Middleton, is the practice in some places in Middlesex. But it is obviously a method of cultivation that can only be attempted on the warm and fertile kinds of turnip soil, and where the pea crops are early ; on the cold heavy and wet descriptions of land, it is obviously impracticable, and wholly improper.

4745. The soil best suited for pease is a dry calcareous sand ; it should be in good tilth, not too rich nor dunged along with the crop. In Norfolk and Suffolk pease are often sown on clover leys after one furrow, or after corn crops on two furrows, one given in autumn, and the other early in spring.

4746. The climate required by the pea is dry and not over warm, for which reason, as the seasons in this country are very often moist and sometimes exceedingly dry and hot in June and July, the pea is one of the most uncertain of field crops.

4747. The season of sowing must differ considerably according to the intentions of the cultivator. When they are grown for podding early for sale green, they should be sown at different times, from January to the end of March, beginning with the driest and most reduced sorts of land ; and in this intention in some southern counties they are put in in the autumn. For the general crops from February to April, as soon as the lands can be brought into proper order is the proper season ; the grey sorts being employed in the early sowings, and the white sorts in the later. Young says, that where these crops cannot be put in in February, they should always be completed in the following month. It is observed by the same writer, in sowing on layers, that the white boiling pea, of many sorts and under various names, is more tender than the greys, and various kinds of hog pease ; but he has many times put them into the ground in February, and though very smart frosts followed, they received no injury. He has uniformly found, that the earlier they were sown the better. There is also a particular motive for being as early as possible : that is, to get them off in time for turnips. This is most profitable husbandry, and should never be neglected. If they are sown in this month and a right sort chosen, they will be off the land in June, so that turnips may follow at the common time of sowing that crop.

4748. *Steeping the seed in water* is sometimes practised in late sowings.

4749. The quantity of seed must be different in different cases and circumstances, and according to the time and manner in which the crop is put into the ground ; but in general, it may be from two and a half to three bushels, the early sowings having the largest proportion of seed. In planting every flag, Young says, two bushels and a half is the usual proportion ; but when drilled at greater distances, six or seven pecks will answer.

4750. The most common mode of sowing pease is broad-cast ; but the advantages of the row culture in the case of a crop so early committed to the soil must be obvious. The best farmers therefore always sow pease in drills either after the plough, the seed being deposited commonly in every second or third furrow, or if the land is in a pulverised state by drawing drills with a machine or by ribbing. In Norfolk and Suffolk pease are generally dibbled on the back of the furrow, sometimes one and sometimes two rows on each ; but dibbling in no manner appears to us so well suited for a farmer's purpose as the drill. In Kent, where immense quantities of pease are grown both for gathering green and for selling ripe to the seedsmen, they are generally sown in rows from eighteen inches to three-feet asunder, according to the kind, and well cultivated between. Pease laid a foot below the surface will vegetate ; but the most approved depth is six inches in light soil, and four inches in clay soil, for which reason they ought to be sown under furrow when the ploughing is delayed till spring. Of all gain, beans excepted ; they are the least in danger of being buried.

4751. *The after culture given to pease is that of hoeing, either by hand or horse. Where the method of hand-culture prevails, it is the general custom to have recourse to two hoeings; the first when the plants are about two or three inches in height, and again just before the period in which they come into blossom. In this way the vigorous vegetation of the young crop is secured, and a fresh supply of nourishment afforded for the setting of the pods and the filling of the pease. At the last of these operations the rows should be laid down, and the earth well placed up to them, the weeds being previously extirpated by hand labor. It has been stated, that in some parts of Kent, where this sort of crop is much grown, it is the practice, when the distance of the rows is sufficiently great, to prevent the vegetation of weeds, and forward the growth of pea crops, by occasionally horse-hoeing, and the use of the brake-harrow, the mould being laid up to the roots of the plants at the last operation by fixing a piece of wood to the barrow. This should, however, only be laid up on one side, the pease being always placed up to that which is the most fully exposed to the effects of the sun.*

4752. *In harvesting the ripened pea considerable care is requisite, both on account of the seed and haulm. When pea crops become ripe they wither and turn brown in the haulm or straw, and the pods begin to open. In this state they should be cut as soon as possible, in order that there may be the least loss sustained by their shedding. It is observed that in the late or general crops, after they are reaped or rather cut up by means of a hook, it is the usual practice to put them up into small heaps, termed wads, which are formed by setting small parcels against each other, in order that they may be more perfectly dried both in the seed and stem, and be kept from being injured by the moisture of the ground. But in the early crops, the haulm is hooked up into loose open heaps, which, as soon as they are perfectly dry, are removed from the ground and put into stacks for the purpose of being converted to the food of animals, on which they are said to thrive nearly as well as on hay. When intended for horses, the best method would seem to be that of having them cut into chaff and mixed with their other food. Young says, that forward white pease will be fit to cut early in July; if the crop is very great they must be hooked; but if small, or only middling, mowing will be sufficient. The stalks and leaves of pease being very succulent, they should be taken good care of in wet weather: the tufts, called wads or heaps, should be turned, or they will receive damage. White pease should always be perfectly dry before they are housed, or they will sell but indifferently, as the brightness and plumpness of the grain are considered at market more than with hog-pease. The straw also, if well harvested, is very good fodder for all sorts of cattle and for sheep; but if it receives much wet, or if the heaps are not turned, it can be used only to litter the farm-yard with. It is the practice in some districts to remove the haulm as soon as it has been cut up by hooks constructed with sharp edges for the purpose, to every fifth ridge, or even into an adjoining grass fields, in order that it may be the better cured for use as cattle food, and at the same time allow of the land being immediately prepared for the succeeding crop. When wet weather happens whilst the pease lie in wads, it occasions a considerable loss, many of them being shed in the field, and of those that remain a great part will be so considerably injured, as to render the sample of little value. This inability in pease to resist a wet harvest, together with the great uncertainty throughout their growth, and the frequent inadequate return in proportion to the length of haulm, has discouraged many farmers from sowing so large a portion of this pulse as of other grain; though on light lands which are in tolerable heart, the profit, in a good year, is far from inconsiderable.*

4753. *In gathering green pease for the market, it is frequently a practice with the large cultivators of early green pea crops in the neighborhood of London, to dispose of them, by the acre, to inferior persons, who procure the podders; but the smaller farmers, for the most part, provide this description of people themselves, who generally apply at the proper season for the purpose. The business of picking or podding the pease is usually performed by the laborers at a fixed price for the sack, of four heaped bushels. The number of this sort of persons is generally in the proportion of about four to the acre, the labor proceeding on the Sundays as well as other days. It is sometimes the custom to pick the crops over twice, after which the rest are suffered to stand till they become ripe for the purpose of seed. This, however, mostly arises from the want of pickers, as it is considered as a loss, from the pease being less profitable in their ripe state than when green. Besides, they are often improper for the purpose of seed, as being the worst part of the crop. It is therefore better to have them clear picked when hands can be procured. After this they are loaded into carts, and sent off at suitable times, according to the distance of the situation, so as to be delivered to the salesmen in the different markets from about three to five o'clock in the morning. In many cases in other parts, the early gatherings are, however, sent to the markets in half-bushel sieves, and are frequently disposed of at the high price of five shillings the sieve; but at the after periods they are usually conveyed in sacks of a narrow form, made for the purpose, which contain about three bushels each, which, in the more early parts of the season, often fetch twelve or fourteen shillings the*

sack, but afterwards mostly decline considerably; in some seasons so much as scarcely to repay the expenses. This sort of crop affords the most profit in such pea seasons as are inclined to be cool, as under such circumstances the pease are most retarded in their maturation or ripening, and of course the markets kept from being over abundantly supplied.

4754. *The threshing of pease* requires less labor than that of any other crop. Where the haulm is wished to be preserved entire it is best done by hand; as the threshing-machine is apt to reduce it to chaff. But where the fodder of pease is to be given immediately to horses on the spot, the breaking it is no disadvantage.

4755. *The produce of the pea* in ripened seeds is supposed by some to be from three and a half to four quarters the acre; others, however, as Donaldson, imagine the average of any two crops together not more than about twelve bushels; and that on the whole, if the value of the produce be merely attended to, it may be considered as a less profitable crop than most others. But as a means of ameliorating and improving the soil at the same time, it is esteemed as of great value.

4756. With respect to the *produce in green pease* in the husk, the average of the early crops in Middlesex is supposed to be from about twenty-five to thirty sacks the acre, which, selling at from eight to eighteen shillings the sack, afford about eighteen pounds the acre. The author of *The Synopsis of Husbandry*, however, states the produce about Dartford, in the county of Kent, at about forty sacks the acre, though, he says, fifty have sometimes been gathered from that space of land.

4757. *The produce of pease in straw* is very uncertain, depending so much on the sort and the season: in general it is much more bulky than that of the cereal grasses; but may be compressed into very little room.

4758. *The produce of pease in flour* is as 3 to 2 of the bulk in grain, and husked and split for soups as 4 to 2. A thousand parts of pea flour afforded Sir H. Davy 574 parts of nutritive or soluble matter, viz. 501 of mucilage or vegetable animal matter, 22 of sugar, 35 of gluten, and 16 of extract or matter rendered insoluble during the operation.

4759. *The use of pease* for soups, puddings, and other culinary purposes, is well known. In some places porridge, brose, and bread is made of pease-flour, and reckoned very wholesome and substantial. In Stirlingshire it is customary to give pease or bean biscuits to horses while in the yoke as a refreshment. The portion of pease that is not consumed as human food is mostly appropriated to the purposes of fattening hogs and other sorts of domestic animals; and, in particular instances, supplies the place of beans, as the provender of laboring horses; but, care should be taken, when used in this way, that they be sufficiently dry, as, when given in the green state, they are said to produce the gripes, and other bowel complaints, in those animals. Bannister, after observing that the haulm is a very wholesome food for cattle of every kind, says, there is generally a considerable demand for pease of every denomination in the market, the uses to which they may be applied being so many and so various. The boilers, or yellow pease, always go off briskly; and the hog-pease usually sell for 6d. or 1s. per quarter more than beans. For feeding swine the pea is much better adapted than the bean, it having been demonstrated by experience, that hogs fat more kindly when fed with this grain than on beans; and, what is not easy to be accounted for, the flesh of swine which have been fed on pease, it is said, will swell in boiling, and be well tasted; whilst the flesh of the bean-fed hog will shrink in the pot, the fat will boil out, and the meat be less delicate in flavour. It has, therefore, now become a practice with those farmers who are curious in their pork, to feed their hogs on pease and barley-meal, and if they have no pease of their own growth, they rather choose to be at the expense of buying them, than suffer their hogs to eat beans. Nay, so far, says he, do some of them carry their prejudice in this particular, as to reject the grey pease for this use, as bearing too near an affinity to the bean, and therefore reserve their growths of white pease solely for hog fattening.

4760. *In boiling split pease*, some samples, without reference to variety, fall or moulder down freely into pulp, while others continue to maintain their form. The former are called boilers. This property of boiling depends on the soil; stiff land, or sandy land, that has been limed or marled uniformly, produces pease that will not melt in boiling, no matter what the variety may be.

4761. *Pease straw cut green* and dried is reckoned as nourishing as hay, and is considered as excellent for sheep.

4762. In the *saving of any particular sorts of pease for seed*, they should be carefully looked over while in flower, in order to draw out all such plants as are not of the right sort; as there will always be, in every sort, some roguish plants, which, if left to mix, will degenerate the kind. As many rows as may be thought sufficient to furnish the desired quantity of seed should then be marked out, and left till their pods turn brown, and begin to split, when they should immediately be gathered up, with the haulm; and if the farmer has not room to stack them till winter, they may be threshed out as soon as

they are dry, and put up in sacks for use : but particular care should be taken not to let them remain too long abroad after they are ripe ; as wet would rot them ; and heat, after a shower of rain, make their pods burst in such a manner that the greater part of their seeds would be lost.

4763. *The diseases of pease are few, and chiefly the worm in the pod and the fly on the leaves and flower. They are also liable to be mildewed or blighted. None of these evils, however, are very common ; and there is no known way of preventing them but by judicious culture.*

SECT. II. *The Bean. — Vicia Faba, L. Diad. Decan. L. and Leguminosæ, J. Fève de marais, Fr. ; Bohm, Ger. ; and Fava, Ital.*

4764. *The bean is a valuable field plant, as affording food for live stock, and in part for man. It is said to be a native of Egypt ; but, like other long domesticated plants, its origin is very uncertain. It has been cultivated in Europe and Asia time out of mind : beans have been long known in Britain, but it is only of late years that they were extensively cultivated upon general soils, being formerly considered as adapted only to rich and moist clays. At that time they were all sown according to the broad-cast system ; in which way, instead of benefiting the ground, they were of incalculable detriment. Weeds got away at the outset, and, in dry seasons, often ruined the crop ; whilst in every season, the grass or perennial weeds, which happened to be in the ground, increased in strength and in quantity, the openness of the bean crop at bottom allowing them to thrive without interruption.*

4765. *The drilling of beans with a small mixture of pease is now become a general practice in every well cultivated district, more particularly in those where soil and climate permit the practice to be successfully executed. In this way not only heavy crops are raised, but, what is of great importance, the ground is kept constantly in good order, provided suitable attention is bestowed upon the cleaning process. This is generally carried on by horse-hoeing the crop at different times, so long as the hoe can be used without doing damage ; and in this way, an able auxiliary is brought forward to the assistance of summer fallow, whereby less stress need be laid upon that radical process than otherwise would be indispensably necessary. (Brown.)*

4766. *The varieties of the bean may be included under two general heads, the white or garden beans, and the grey or field beans. Of the white beans sown in the fields, the Mazagan and long-pod are almost the only sorts. Of the grey beans, that known as the horse-bean, the small or ticks, and the prolific or Heligoland, are the chief sorts. New varieties are procured in the same manner as in other plants.*

4767. *In the choice of sorts, tick beans are supposed by some farmers to be more productive than horse-beans ; but the latter grow higher in the stem, and produce a more stagnated state of the air, or smother the land more, consequently are the most suitable for the stronger sorts of soil ; and Young remarks, that "the common little horse-bean has the advantage of all others in being more generally marketable ; for, in certain situations, it is not always easy to dispose of ticks, Windsors, long-pods, and various other large sorts. They also grow higher, shade the ground in summer more from the sun, and yield a larger quantity of straw, which makes excellent manure. But some of the other sorts are generally supposed to yield larger products. In purchasing beans for seed, care should be taken to choose such as are hard and bright, without being shrivelled in their appearance."*

4768. *The best soils for beans are clays and strong loams : on such soils they generally succeed wheat or oats, but sometimes also clover leys. Turnip soils or sands are by no means proper for them.*

4769. *In the preparation of the soil, much depends on the nature of the land and the state of the weather ; for as beans must be sown early in the spring, it is sometimes impossible to give it all the labor which a careful farmer would wish to bestow. It must also be regulated, in some measure, by the manner of sowing. In all cases it ought to be ploughed with a deep furrow after harvest, or early in winter : and as two ploughings in spring are highly advantageous, the winter furrow may be given in the direction of the former ridges, in which way the land is sooner dry in spring than if it had been ploughed across. The second ploughing is to be given across the ridges, as early in spring as the ground is sufficiently dry ; and the third furrow either forms the drills, or receives the seed. (Supp. E. Brit. art. Agr.)*

4770. *Brown, one of the best bean growers in Britain, gives the following directions. The furrow ought to be given early in winter, and as deep as possible, that the earth may be sufficiently loosened, and room afforded for the roots of the plant to search for the requisite nourishment. This first furrow is usually given across the field, which is the best method when only one spring furrow is intended ; but as it is now ascertained, that two spring furrows are highly advantageous, perhaps the one in winter ought to be given in length, which lays the ground in a better situation for resisting the rains, and renders*

it sooner dry in spring, than can be the case when ploughed across. On the supposition, that three furrows are to be given, one in winter, and two in spring, the following is the most eligible preparation. The land being ploughed in length, as early in winter as is practicable, and the cross gutter and headland furrows sufficiently digged out, take the second furrow across the first as soon as the ground is dry enough in spring to undergo the operation; water-furrow it immediately, and dig again the cross gutter and headland furrows, otherwise the benefit of the second furrow may be lost. This being done, leave the field for some days, till it is sufficiently dry, when a cast of the harrows becomes necessary, so that the surface may be levelled. Then enter with the ploughs, and form the drills. (*Treatise on Rural Affairs.*)

4771. *Manure is frequently applied to the bean crop*, especially if it succeeds wheat. By some, dung is spread on the stubble previous to the winter ploughing, but this cannot always be done in a satisfactory manner, at least in the northern parts of the island, unless during frost, when it may lie long exposed to the weather before it can be turned down by the plough. The most desirable mode therefore is, to lay the manure into drills immediately before the beans are sown. (*Supp. &c.*)

4772. According to Brown, the best way is to *apply the dung on the stubble before the winter furrow is given*, which greatly facilitates the after process. Used in this way, a fore stock must be in hand; but where the farmer is not so well provided, spring dunging becomes necessary, though evidently of less advantage. At that season, it may either be put into the drills before the seed is sown, or spread upon the surface and ploughed down, according to the nature of the drilling process, which is meant to be adopted. Land dunged to beans, if duly hoed, is always in high order for carrying a crop of wheat in succession. Perhaps better wheat, both in respect of quantity and quality, may be cultivated in this way, than in any other mode of sowing.

4773. *The climate most favorable to the bean is one neither very dry nor very moist*, he first brings on the fly, and the last prevents the setting of the blossoms. In general, however, a dry summer is most favorable to the production of corn, and moist weather to the growth of the haulm.

4774. *The time of sowing beans is as early as possible after the severity of winter is over*; in the south, sometimes in January, but never later than the end of March; as the ripening of the crop and its safe harvesting would otherwise be very precarious in this climate. Bannister thinks, that the proper time for planting beans in Kent is towards the latter end of January, or early in the following month; though this business may be continued to advantage till the middle or latter end of March, if the weather had prevented their being got in at an earlier season: but in general it is best to embrace the first opportunity of sowing them after Candlemas, as they often miscarry if the season be procrastinated beyond that time, especially if a dry summer should succeed.

4775. *The mode of sowing is almost always in rows*. Though still sown broad-cast in several places, and sometimes dibbled, they are, for the most part, drilled by judicious cultivators, or deposited after the plough in every furrow, or only in every second or third furrow. In the latter method, the crop rises in rows, at regular intervals of nine, eighteen, or twenty-seven inches, and the hand-hoe ought invariably to be employed; but it is only where the widest interval is adopted, that the horse-hoe can be used with much effect in their subsequent culture.

4776. *There are two modes of drilling beans*. In one of these, the lands, or ridges, are divided by the plough into ridgetlets, or one bout stitches, at intervals of about twenty-seven inches. If dung is to be applied, the seed ought to be first deposited, as it is found inconvenient to run the drill-machine afterwards. The dung may then be drawn out from the carts in small heaps, one row of heaps serving for three or five ridgetlets; and it is evenly spread, and equally divided among them, in a way that will be more minutely described when treating of the culture of turnips. The ridgetlets are next split out or reversed, either by means of the common plough, or one with two mould-boards, which covers both the seed and the manure in the most perfect manner. When beans are sown by the other method, in the bottom of a common furrow, the dung must be previously spread over the surface of the winter or spring ploughing. Three ploughs then start in succession, one immediately behind another, and a drill barrow either follows the third plough, or is attached to it, by which the beans are sown in every third-furrow, or at from twenty-four to twenty-seven inches asunder, according to the breadth of the furrow-slice.

4777. *Another approved way of sowing beans*, when dung is applied at seed-time, is to spread the dung and to plough it down with a strong furrow; after this shallow furrows are drawn, into which the seed is deposited by the drill-machine. Whichever of these modes of sowing is followed, the whole field must be carefully laid dry by means of channels formed by the plough, and when necessary by the shovel; for neither then nor at any former period should water be allowed to stagnate on the land.

4778. *The dibbling of beans is considered by Arthur Young as an excellent method*, when well performed; but the grand objection to it is the difficulty of getting it well done. When it becomes the common husbandry of a district, the workmen find that great earnings are to be made by it; and this is much too apt to make them careless, and eager to earn still more; and if a very minute attention be not paid to them, by the constant attendance of the farmer, they strike the holes so shallow, that the first peck of a rook's bill takes the seed, and acres may be destroyed, if the breed of those birds be encouraged. Boys are employed for weeks together to keep the fields, but all works

that depend on boys are horribly neglected, and thus the farmer suffers materially; but if the seed is deposited two and a half, or (better) three inches deep, it is not so easily eradicated. In some districts, as Middlesex, Surrey, &c. the method is, to plant this pulse in rows stricken out by a line, by which a great saving is made in the article of seed, a circumstance which is thought to compensate for the extraordinary charge of this mode of husbandry; and thus far may be fairly acknowledged, that the method of planting beans by the dibber is greatly to be preferred to that of sowing the seed at random; the economy of this agricultural process is thus explained: the rows are marked out one foot asunder, and the seed planted in holes made two inches apart: the lines are stretched across the lands, which are formed about six feet over, so that when one row is planted, the sticks to which the line is fastened are moved by a regular measurement to the distance required, and the same method pursued till the field is completed. The usual price for this work is ninepence per peck, and the allowance two bushels per acre. Great confidence must necessarily be reposed in the people who transact the business of planting beans by the dibber, who, if inclined to fraud, have it in their power to deceive their employer by throwing great part of the seed into the hedge, from which their daily profits are considerably enhanced, their own labor spared, and every discovery effectually precluded, till the appearance of the crop, when the frequent chasms in the rows will give sufficient indications of the fraud; and by this time, perhaps, the villainous authors of the mischief may have escaped all possibility of detection, by having conveyed themselves from the scene of their iniquity.

4779. *The quantity of seed* allowed is very different in the southern and northern parts of Britain; in the former, even when the rows are narrow, only two bushels or two bushels and a half; but in Scotland, seldom less than four bushels to the English statute acre, even when sown in ridgelets twenty-seven inches distant, and a bushel more when sown *broad-cast*. We seldom have seen thin beans turn out well, unless the soil is particularly rich; nay, unless the rows close, weeds will get away after the cleaning process is finished, thereby disappointing the object of drilling, and rendering the system of little avail towards keeping the ground in good condition. Both in the broad-cast and drill husbandry, it is common to mix a small quantity of pease along with beans. This mixture improves both the quantity and quality of the straw for fodder, and the pease-straw is useful for binding up the sheaves in harvest.

4780. *The after culture* of the bean crop commences with harrowing just before the young plants reach the surface. When sown in rows, in either of the modes already mentioned, the harrows are employed about ten or twelve days after; and, being driven across the ridgelets, the land is laid completely level for the subsequent operations, and the annual weeds destroyed.

4781. *After the beans have made some growth*, sooner or later, according as the soil may happen to be encumbered with or free from weeds, the horse-hoe is employed in the interval between the rows; and followed by the hand-hoe for the purpose of cutting down such weeds as the horse-hoe cannot reach; all the weeds, that grow among the beans beyond the reach of either hoe, should be pulled up with the hand. The same operations are repeated as often as the condition of the land, in regard to cleanness, may require.

4782. *Before the introduction of the horse-hoe*, which merely stirs the soil, and cuts up the weeds, a common small plough, drawn by one horse, was used in working between the rows, and is still necessary where root-weeds abound. This plough goes one bout, or up and down in each interval, turning the earth from the beans, and forming a ridgelet in the middle; then hand-hoes are immediately employed; and after some time, a second hand-hoeing succeeds to destroy any fresh growth of weeds. The same plough, with an additional mould-board, finally splits open the intermediate ridgelet, and lays up the earth to the roots of the beans on each side. The benefit of laying up the earth in this manner, however, is alleged to be counterbalanced by the trouble which it occasions in harvest, when it is difficult to get the reapers to cut low enough, and may be properly dispensed with, unless the soil be very wet and level.

4783. *In moist warm seasons*, this grain hardly ever ripens effectually; and it is exceedingly difficult to get the straw into a proper condition for the stack. In such cases, it has been found of advantage to switch off the succulent tops with an old scythe blade set in a wooden handle, with which one man can easily top-dress two acres a day. This operation, it is said, will occasion the crop to be ready for reaping a fortnight earlier, and also, perhaps a week sooner ready for the stack-yard after being reaped.

4784. *Before reaping beans* the grain ought to be tolerably well ripened, otherwise the quality is impaired, whilst a long time is required to put the straw in such a condition as to be preserved in the stack. In an early harvest, or where the crop is not weighty, it is an easy matter to get beans sufficiently ripened; but, in a late harvest, and in every one where the crop takes on a second growth, it is scarcely practicable to get them thoroughly ripened for the sickle. Under these circumstances, it is unnecessary to let beans stand

uncut after the end of September, or the first of October; because any benefit that can be gained afterwards, is not to be compared with the disadvantages that accompany a late wheat seed-time. Beans are usually cut with the sickle, and tied in sheaves, either with straw ropes, or with ropes made from pease sown along with them. It is proper to let the sheaves lie untied several days, so that the winning process may be hastened, and, when tied, to set them up on end, in order that full benefit from the air may be obtained, and the grain kept off the ground. (*Brown.*)

4785. *Beans are sometimes mown, and in a few instances, even pulled up by the roots.* They should in every case be cut as near the ground as possible, for the sake of the straw, which is of considerable value as fodder, and because the best pods are often placed on the stems near the roots. They are then left for a few days to wither, and afterwards bound and set up in shocks to dry, but without any head sheaves. (*Supp. &c.*)

4786. *Beans are stacked either in the round or oblong manner, and it is always proper, if the stack be large, to construct one or more funnels to allow a free circulation of air.*

4787. *The threshing of beans is nearly as easy as that of pease.* Threshing them by a machine may be considered advantageous as breaking the coarser ends of the straw, and separating the earth from their root-ends, or roots, if they have been reaped by pulling.

4788. *The produce of beans, when proper management is exercised, and where diseases have not occurred, is generally from twenty-five to thirty-five bushels per acre.* Donaldson says, that a crop of beans, taking the island at large, may be supposed to vary from sixteen to forty bushels, but that a good average crop cannot be reckoned to exceed twenty. In Middlesex, Middleton tells us, that bean-crops vary from ten to eighty bushels per acre. They are rendered a very precarious crop by the ravages of myriads of small black insects of the same species. The lady-birds (*Coccinella*) are supposed to feed on them, as they are observed to be much among them. Foot says, the average produce is from three and a half to four quarters per acre. In Kent, A. Young thinks, they probably exceed four quarters; but in Suffolk, he should not estimate them at more than three; yet five or six are not uncommon.

4789. *The produce in haulm, in moist seasons, is very bulky.*

4790. *In the application of beans, the grain in Scotland is sometimes made into meal, the finer for bread and the coarser for swine; but beans are for the most part applied to the purpose of feeding horses, hogs, and other domestic animals.* In the county of Middlesex, all are given to horses, except what are preserved for seed, and such as are podded while green, and sent to the London markets. When pigs are fed with beans, it is observed that the meat becomes so hard as to make very ordinary pork, but good bacon. It is also supposed that the mealmen grind many horse-beans among wheat to be manufactured into bread.

4791. *The flour of beans is more nutritive than that of oats, as appears in the fattening of hogs; whence, according to the respective prices of these two articles, Dr. Darwin suspects that pease and beans generally supply a cheaper provender for horses than oats, as well as for other domestic animals.* But as the flour of pease and beans is more oily, he believes, than that of oats, it may in general be somewhat more difficult of digestion; hence, when a horse has taken a stomach-full of pease and beans alone, he may be less active for an hour or two, as his strength will be more employed in the digestion of them than when he has taken a stomach-full of oats. A German physician gave to two dogs, which had been kept a day fasting, a large quantity of flesh food; and then taking one of them into the fields, hunted him with great activity for three or four hours, and left the other by the fire. An emetic was then given to each of them, and the food of the sleeping dog was found perfectly digested, whilst that of the hunted one had undergone but little alteration. Hence it may, he says, be found advisable to mix bran of wheat with the pease and beans, a food of less nutriment but of easier digestion; or to let the horses eat before or after them the coarse tussocks of sour grass, which remain in moist pastures in the winter; or, lastly, to mix finely-cut straw with them. It is observed in the fifth volume of *The Bath Papers*, that it has been found by repeated experience, that beans are a much more hearty and profitable food for horses than oats. Being out of old oats the two last springs, the writer substituted horse-beans in their stead. In the room of a sack of oats with chaff, he ordered them a bushel of beans with chaff, to serve the same time. It very soon appeared the beans were superior to the oats, from the life, spirit, and sleekness of the horses.

4792. *Bean straw, when mixed with pease, Brown considers as affording almost as much nourishment when properly harvested, as is gained from hay of ordinary quality; when it is well got the horses are fonder of it than of pease straw.* It should either be given when newly threshed, or else stacked up and compressed by treading or coverings, as the air is found materially to affect both its flavor and nutritive quality.

4793. *The produce of beans in meal is like that of pease, more in proportion to the grain than in any of the cereal grasses.* A bushel of beans is supposed to yield fourteen



pounds more of flour than a bushel of oats, and a bushel of pease eighteen pounds more, or, according to some, twenty pounds. A thousand parts of bean flour were found, by Sir H. Davy, to yield 570 parts of nutritive matter, of which 426 were mucilage or starch, 103 gluten, and 41 extract, or matter rendered insoluble during the process.

4794. *The diseases of beans* are, the rust, the honey-dew, mildew, and black fly or aphides. These diseases are brought on by very dry weather; the fly almost always succeeds the honey-dew; both are most prevalent on the summits of the plants, and some have attempted to mitigate the evil by cutting them off. In general, however, these diseases are without remedy, either preventive or positive. In extreme cases they destroy both the leaves, stalks, and fruit; and when this is foreseen, the best thing the farmer can do is to mow them or plough them down, and prepare the land for wheat or otherwise, according to the rotation.

SECT. III. *The Tare.* — *Vicia sativa*, L. *Diadel. Decan.* L. and *Leguminosæ*, J. *Vesce*, Fr.; *Wicke*, Ger.; and *Loglio*, Ital.

4795. *The tare, vetch, or fitch* (*Vicia sativa*, fig. 564.), has been cultivated for its stem and leaves from time immemorial. It is considered as a native plant, and is found wild also in China and Japan. Ray, in 1686, informs us that the common tare or vetch, was then sown almost all over Europe; that it was chiefly used in England, mixed with pease and oats, to feed horses; but that it was sometimes sown separately for soiling cattle, and was reputed to cause milch cows to yield much milk. The tare, Brown observes, is of hardy growth, and, when sown upon rich land, will return a large supply of green fodder for the consumption of horses, or for fattening cattle.

4796. *The varieties of tares* are chiefly two, the winter and spring tare; both have local names, as gore vetch, rath ripe vetch, &c. Some consider them as distinct species, but this is doubtful. As the result of an experiment tried for two years at Bury, in Suffolk, Professor Martyn observes, that there appears a material difference in the constitution, if we may so call it, of the two tares in question. Not to say any thing of a trifling difference in the color and size of their seeds, the only visible marks of distinction seems to be a disparity in the first leaves of the upright stalks, which, in the spring tare, are elliptic and rounded or notched at the end; but in the winter tare, linear and drawn to a point. The leaves on the branches which afterwards issue below, and in time form the bulk of the plants, are the same in both vetches. But whatever the difference may be, it is evident that the seeds of the two sorts ought to be kept separate, since each sown out of its proper season is found not to prosper.

4797. *New varieties of tare* may be obtained by the usual means; and it is thought that some of the numerous species of this plant, which are natives of Europe, might be cultivated with advantage. The *vicia narbonnensis* and *seratifolia* are cultivated in Germany. Dr. Anderson has recommended the *V. sepium*; and a writer in *The Bath Agricultural Transactions*, the *V. cracca*. Some species of *lathyrus*, *orobus*, and *ervum*, might probably also be tried with success.

4798. *In choosing between the spring and winter tare*, every thing must depend on the intention of the crop. If the object is to have early feed, the winter variety is undoubtedly to be preferred; but where the land is foul and requires to be two or three times ploughed in spring, or where a late crop is desired, or a crop for seed, then the spring variety will generally deserve the preference.

4799. *The soil preferred by the tare* is a clay, but they will grow in any rich soil not over dry. In a moist climate, the haulm grows so luxuriant as to rot at bottom; and in one over dry it is deficient in length. A dry season, however, is on the whole more favorable than a moist one, as this crop soon covers the surface.

4800. *The preparation of the soil* seldom consists of more than one ploughing, if for autumn sowing; and of a winter and spring ploughing, when to be sown in spring. If in the latter case, the land is very foul, several ploughings are given, or one ploughing and several stirrings with the cultivator. In general, tares succeed some of the corn crops. In England manure is sometimes given either with a view to eating them off early, and following with a crop of turnips, or to the enriching the soil for a crop of wheat.

4801. *The time of sowing* depends on the kind of tare, and the purpose in view. The winter variety is sown in September and October; and the first sowing in spring ought to be as early as the season will permit. If they are to be cut green for soiling through-

564



out the summer and autumn, which is the most advantageous method of consuming them, successive sowings should follow till the end of May. Summer tares, when meant for seed, Brown observes, ought to be sown early, "otherwise the return will be imperfect; but when for green food, any time betwixt the first of April and the latter end of May will answer well, provided crops in succession, from the first to the last mentioned period, be regularly cultivated. Instances are not wanting of a full crop being obtained even when the seed was sown so late as the middle of June, though sowing so late is a practice not to be recommended. In Middlesex, the winter-sowings are commenced about the beginning of August: in the northern counties no winter-sowings are made, as the tare there will not endure the severity of the season.

4802. *The mode of sowing tares* is mostly broad-cast, which should be performed as evenly as possible over the surface of well-prepared land; the seeds being afterwards covered in by proper harrowing, in order to prevent their being picked up by birds, and ensure their perfect vegetation and growth. It has been suggested, however, that in rich clean soil, it is probable the row-method would succeed well with this sort of crop, as Marshal states, is the practice in some of the southern districts of the island. After the seed is sown, and the land carefully harrowed, a light roller ought to be drawn across, so that the surface may be smoothed, and the scythe permitted to work without interruption. It is proper also to guard the field for several days against the depredations of pigeons, who are remarkably fond of tares, and will pick up a great part of the seed, unless constantly watched.

4803. *The quantity of seed* to an acre is from two and a half to three and a half bushels, according to the time of sowing, and as they are to be consumed green or left to stand for a crop. When tares are intended for seed, less seed is required than when they are grown for soiling or for drying the haulm. A writer in *The Farmer's Magazine* (vol. i.) has suggested that the most productive method of sowing this crop, when intended for seed, is to mix them amongst beans when drilled, at the rate of one firlof of tares to one boll of beans. From trials made, it is ascertained, it is said, that the quality of the tares is vastly improved by being blended with beans, as, by clinging to the latter, they are kept from the ground, and enjoy the full benefit of the sun, for ripening them in a perfect manner; and they are in this way much easier harvested than when sown by themselves. They answer, at the same time, for bands to tie the principal crop; and the produce may, on an average of seasons, be considered as at least double. A little rye sown with winter tares, and a few oats with the spring sort, not only serve to support the weak creeping stems of the tares, but add to the bulk of the crop by growing up through the interstices.

4804. In the *choice of the seed* it is hardly possible to distinguish the grain of the winter from that of the spring variety: the former is alleged to be rather smaller and lighter colored; but the only reliance must be on the honesty of the vendor. Plump seed and a sample free from the seeds of weeds, will of course be selected, whatever be the variety.

4805. *The after culture* given to tares consists merely in pulling out the larger weeds, unless they are in rows, in which case the horse or hand-hoe is applied; or intended for seed, in which case weeding must be more particularly executed.

4806. In *reaping tares for soiling* they ought always to be cut with the scythe, as, the sickle by breaking asunder the stalks, and tearing up a number by the roots, renders the second crop of little value. When mown early, they will in a moist season produce three mowings, but generally two. In reaping tares for seed, they may be either mown or taken with the sickle, and treated like pease in drying, stacking, and threshing.

4807. Tares are *eaten off the ground* in some places by different kinds of live-stock, particularly by sheep; and as the winter-sown variety comes very early in spring, the value of this rich food is then very considerable. The waste, however, in this way, even though the sheep be confined in hurdles, must be great; and still greater when consumed by horses or cattle.

4808. *Tare crops are sometimes made into hay*, in which case more attention is found necessary than in those of most of the artificial grasses, as wet is more injurious to them, and they require more sun and air; but in other respects they demand the same cautious management, in order to preserve the foliage from being lost. The time for cutting for this purpose is, according to the author of *The Synopsis of Husbandry*, when the blossoms have declined and they begin to fall and lie flat. When well made, the hay is of the best and most nutritious quality or properties.

4809. *The produce of tares cut green* is, according to Middleton, ten or twelve tons per acre, which is a large crop; and when made into hay at about three tons the acre, which shows the disadvantage of making these crops into hay. And it is found, that the spring tare crops are lighter, and most liable to be injured by a dry season.

4810. *The produce in seed* is likewise found to be considerable, being by some stated at from three to six sacks; but in other instances forty bushels, or more, have been obtained from the acre.

4811. *In the application of tares* they are found to be a hearty and most nourishing food

for all sorts of cattle. Cows give more butter when fed with this plant than with any other food whatsoever. Horses thrive better upon tares than they do upon clover and ryegrass; and the same remark is applicable to fattening of cattle, who feed faster upon this article of green fodder, than upon any kind of grass or esculent with which we are acquainted. Danger often arises from their eating too many, especially when podded; as colics, and other stomach disorders, are apt to be produced by the excessive loads which they devour. Perhaps a great quantity of fixed air is contained in this vegetable; and as heavy crops are rarely dry at the root when cut, it is not to be wondered that accidents often happen, when the animal is indulged with the unrestrained consumption of them. Were oat straw mixed with the tares in the racks or stalls in which they are deposited, it is probable that fewer accidents would follow, though this assistant is only required when the tares are wet, foul, or over succulent. If the plants be cut green, and given to live-stock, either on the field, or in the fold-yards, there is, perhaps, no green crop of greater value, nor any better calculated to give a succession of herbage from May to November. The winter-sown tare, in a favorable climate, is ready for cutting before clover. The first spring crop comes in after the clover must be all consumed or made into hay; and the successive spring sowings give a produce more nourishing for the larger animals than the aftermath of clover, and may afford green food at least a month longer. In the county of Sussex, Young observes, "tare crops are of such use and importance that not one-tenth of the stock could be maintained without them; horses, cows, sheep, hogs, all feed upon them; hogs are soiled upon them without any other food. This plant maintains more stock than any other plant whatsoever. Upon one acre, Davis maintained four horses in much better condition than upon five acres of grass. Upon eight acres he has kept twelve horses and five cows for three months without any other food: no artificial food whatever is equal to this excellent plant." This statement must be coupled with the usual produce of turnips in Sussex, 10 or 15 tons per acre: hence the supposed superiority of tares to every other green crop. Tares cut green, Professor Thier observes, draw no nourishment from the soil whatever, while made into hay, they afford a fodder preferred by cattle to pease-straw, and more nutritive than hay or any other herbage.

4812. *The use of the grain of tares* is generally for reproduction; but they are also given to pigeons, by whom they are highly relished, and it is thought they would form a very good food for poultry. In Germany they are given to horses, cows, sheep, and swine.

4813. *The diseases of tares* are so few as to be of no consequence. A crop is sometimes, but rarely, lost by mildew.

#### SECT. IV. *Of other Leguminous Grains, which might be cultivated in British Farming.*

4814. *The lentil, kidneybean, and chick pea* are grown both in France and Germany as field plants for their grains, to be used as food. They are by no means likely to become articles of general culture in Britain; but it is worth while to know that they may be cultivated here instead of being imported, and also that they form very excellent articles of human food.

4815. *The lentil* is the *Ervum lens*, L. *Les lentilles*, Fr.; *Lentzen*, Ger.; and *Lenticcia*, Ital. (fig. 565.) It is a legume of the greatest antiquity, being in esteem in Esau's time, and much prized in eastern countries ever since. In Egypt and Syria, they are parched in a frying-pan and sold in the shops, and considered by the natives as the best food for those who undertake long journeys. The lentil is considered a native of France, but has been known in England from the earliest agricultural records. In Gerarde's time, they were sown like tates, their haulm given to cattle, and the grain to pigeons, and used in meagre soups.

4816. *There are three varieties of lentils* cultivated in France and Germany; the small brown, which is the lightest flavored, and the best for haricots and soups; the yellowish, which is a little larger, and the next best; and the lentil of Provence, which is almost as large as a pea with luxuriant straw, and more fit to be cultivated as a tare, than for the grains as human food.

4817. *A dry warm sandy soil* is requisite for the lentil; it is sown rather later than the pea, at the rate of a bushel or one and a half bushels to the acre; in other respects its culture and harvesting are the same, and it ripens sooner. The lentil, Young observes, is a crop not uncommon about Chesterford in Essex, where they sow a bushel an acre on one ploughing in the beginning or middle of March. It is there the custom to make hay of them, or seed them, for cutting into chaff for trough-meat for sheep and horses, and they sow them on both heavy and dry soils. It is, however, added, that the whole country is of a calcareous nature. It is likewise stated, that attention should



be paid not to water horses soon after eating this sort of food, as they are apt to hove them. They are likewise asserted to be cultivated for the same purpose in Oxfordshire, and probably in other districts.

4818. *The produce of the lentil in grain is about a fourth less than that of the tare; and in straw it is not a third as much, the plants seldom growing above one and a half feet high. The straw is, however, very delicate and nourishing, and preferred for lambs and calves, and the grain on the continent sells at nearly double the price of pease. Einhoff obtained from 3840 parts of lentils, 1260 parts of starch, and 1433 of a matter analogous to animal matter.*

4819. *The use of the lentil on the continent is very general, both in soups and dressed with a butter sauce as haricot. They are imported from Hamburg, and sold in London for the same purpose.*

4820. *The chick pea (Cicer arietinum, fig. 55.), grows naturally in the south of Europe, and is cultivated there for the same purposes as the lentil, but it is too delicate for field culture in this country.*

4821. *The kidneybean (Phaseolus vulgaris, L. Haricot, Fr.; Schmitzbohne, Ger.; and Fagiolo, Ital.) is a native of India, but ripens readily in dry summers in most parts of Britain. Its culture has been hitherto confined to gardens, but it might be grown equally well in dry, warm, rich, and sheltered soils, being grown in the fields of Germany, Switzerland, and similar climates. The sort generally used for this purpose is the small dwarf white; the ground is prepared by several stirrings, and the seed is dibbled in rows eighteen inches or two feet asunder in the beginning of May. The ground is hoed and weeded during the summer, and the crop is ripe in August. It is usually harvested by pulling up the plants, which, being dried, are stacked or threshed. The haulm is of little bulk or use, but the grain is used in making the esteemed French dish called haricot, which it were desirable the cottagers of this country were made acquainted with. There is perhaps no other vegetable dish so cheap and easily cooked, and at the same time so agreeable and nourishing. The beans are boiled and then mixed with a little salt butter or other fat, and a little milk or water, and flour. From 3840 parts of kidneybean, Einhoff obtained 1805 parts of matter analogous to starch, 851 of vegeto-animal matter, and 799 parts of mucilage. Haricots and lentils are much used in all Catholic countries during Lent and maigre days, as they, from their peculiar constituents, form so excellent a substitute for animal food. During the prevalence of the Roman religion in this country, they were probably much more generally used than at present; as reformations are often carried farther than is necessary, possibly lentils may have been left off by Protestants, lest the use of them may have been considered a symptom of popery.*

4822. *The lupin (Lupinus luteus, L. fig. 566.), was cultivated by the Romans as a legume, and is still occasionally grown in Italy. The grain was formerly, and is occasionally now used as food; but more generally the whole plant is mown and given as herbage to cattle, and sometimes the crop is ploughed down as manure.*



#### CHAP. IV.

##### *Of Plants cultivated for their Roots or Leaves.*

4823. *Plants cultivated for their roots or leaves are various, and most of them are adapted both for human food and that of domestic animals; but some are chiefly or entirely grown for the nurture of live-stock. The plants which we include under this head, are the potatoe, turnip, carrot, parsnep, beet, cabbage tribe, lettuce, and chicory. The culture of roots may be considered a branch of farming almost entirely of modern origin, and more peculiarly British than any other department. Turnips were cultivated by the Romans, and in modern times brought into notice as objects of field culture in the last century, but they were most imperfectly managed, and of very little utility in agriculture till their culture was undertaken by the British farmer. The potatoe, carrot, and parsnep, were also first cultivated in the fields of this country. Friable or light soil, superior pulverisation, and manuring, the row-method, and careful after-culture, are essential to the maturation of the plants to be treated of in this Chapter; and hence the importance of such crops as preparations for those of the bread corns.*

4824. *The nutritive products of these plants are thus given by Sir H. Davy :*

Systematic name.	The quantity analysed, of each sort 1000 parts.	Whole quantity of soluble or nutritive matter.	Mucilage or starch.	Saccharine matter or sugar.	Gluten or albumen.	Extract, or matter rendered insoluble during evaporation.
<i>Solanum tuberosum</i>	Potatoe	From 260 to 200.	From 200 to 155.	From 20 to 15.	From 40 to 30.	
<i>Beta vulgaris</i>	Red beet	148	14	121	13	
<i>Brassica rapa</i>	Common turnip	42	7	34	1	
var. <i>ruta baga</i>	Swedish turnip	64	9	51	2	2
<i>Daucus carota</i>	Carrot	98	3	95		
	Parsnep	99	9	90		
<i>Beta cicla</i>	White beet	136	13	119	4	
<i>Brassica oleracea</i>	Cabbage	73	41	24	8	

SECT. I. *The Potatoe.* — *Solanum tuberosum*, L. *Pentan. Monog. L.* and *Solanææ*, J. *Pomme de Terre*, Fr.; *Cartoffel*, Ger.; *Tartufflo* or *Pomo di Terra*, Ital.

4825. *The potatoe* is supposed to be a native of South America; but Humboldt is very doubtful if that can be proved; he admits, however, that it is naturalised there in some situations. Sir J. Banks (*Hort. Trans.* vol. i. p. 8.) considers that the potatoe was first brought into Europe from the mountainous parts of South America, in the neighborhood of Quito, where they were called *papas*, to Spain, in the early part of the sixteenth century. From Spain, where they were called *battatas*, they appear to have found their way first to Italy, where they received the same name with the truffle, *taratouffi*. The potatoe was received by Clusius, at Vienna, in 1598, from the governor of Mons, in Hainault, who had procured it the year before from one of the attendants of the Pope's legate, under the name of *taratoufflo*, and learned from him that it was then in use in Italy. In Germany it received the name of *cartoffel*, and spread rapidly even in Clusius's time.

4826. *To England the potatoe was brought from Virginia* by the colonists sent out by Sir Walter Raleigh in 1584, and which returned in July 1586, and "probably," according to Sir Joseph Banks, "brought with them the potatoe." Thomas Herriot, in a report on the country, published in De Bry's *Collection of Voyages*, (vol. i. p. 17.) describes a plant called *openawk*, with "roots as large as a walnut, and others much larger; they grow in damp soil, many hanging together, as if fixed on ropes; they are good food, either boiled or roasted." Gerarde, in his *Herbal*, published in 1597, gives a figure of the potatoe, under the name of the *potatoe of Virginia*, whence, he says, he received the roots; and this appellation it appears to have retained, in order to distinguish it from the *battatas*, or sweet potatoe (*Convolvulus ballatas*), till the year 1640, if not longer. "The sweet potatoe," Sir Joseph Banks observes, "was used in England as a delicacy long before the introduction of our potatoes: it was imported in considerable quantities from Spain and the Canaries, and was supposed to possess the power of restoring decayed vigor. The kissing comfits of Falstaff, and other confections of similar imaginary qualities, with which our ancestors were duped, were principally made of these and of eringo roots."

4827. *The potatoe was first planted by Sir William Raleigh* on his estate of Youghall, near Cork, and Gough says, was "cherished and cultivated for food" in that country before its value was known in England; for, though they were soon carried over from Ireland into Lancashire, Gerarde, who had this plant in his garden in 1597, under the name of *Battata Virginiana*, recommends the roots to be eaten as a delicate dish, not as common food. Parkinson mentions, that the tubers were sometimes roasted, and steeped in sack and sugar, or baked with marrow and spices, and even preserved and candied by the comfit-makers.

4828. *For encouraging the cultivation of potatoes*, with the view of preventing famine, the Royal Society took some measures in 1633. Still, however, although their utility as an article of food was better known, no high character was bestowed on them. In books of gardening, published towards the end of the seventeenth century, a hundred years after their introduction, they are spoken of rather slightly. "They are much used in Ireland and America as bread," says one author, "and may be propagated with advantage to poor people." "I do not hear that it hath been yet essayed," are the words of another, "whether they may not be propagated in great quantities, for food for swine or other cattle." Even the enlightened Evelyn seems to have entertained a prejudice against them: "Plant potatoes," he says, writing in 1699, "in your worst ground. Take them up in November for winter spending; there will enough remain for a stock, though ever so exactly gathered." But the use of potatoes gradually spread, as their excellent qualities became better understood. It was near the middle of the eighteenth century, however, before they were generally known over the country: since that time they have been most extensively cultivated. In 1796, it was found, that in the county of Essex alone, about 1700 acres were planted with potatoes for the supply

of the London market. This must form, no doubt, the principal supply; but many fields of potatoes are to be seen in the other counties bordering on the capital, and many ship-loads are annually imported from a distance. In every county in England, it is now more or less an object of field culture.

4829. *Potatoes, as an article of human food*, are, next to wheat, of the greatest importance in the eye of the political economist. From no other crop that can be cultivated will the public derive so much food as from this valuable esculent; and it admits of demonstration, that an acre of potatoes will feed double the number of people that can be fed from an acre of wheat. Potatoes are also a nourishing and healthy food, relished by almost every palate; and it is believed there is hardly a dinner served up for six months in the year without them, in any part of the kingdom. Notwithstanding all these things, and they are of great importance in one point of view, we are doubtful whether potatoes can be placed so high in the scale as several other articles of produce, when the profit and loss account of the agriculturist is to be ascertained. They require a great deal of manure from the farmer; while, generally speaking, little is returned by them; they are a bulky unhandy article, troublesome in the lifting and carrying processes, and interfering with the seed season of wheat, the most important one to the farmer. After all, from particular circumstances, they cannot be vended unless when raised in the vicinity of large towns; hence they are in most respects an unprofitable article to the agriculturist. To him the real criterion is the profit which potatoes will return in feeding beasts; and here we apprehend, the result will altogether be in favor of turnips, and ruta бага, as the most profitable articles for that purpose.

4830. *What is called the yam, or Surinam potatoe*, is of more importance to the farmer, because with this variety he has an excellent assistant to his turnip crop, or rather a succedaneum, which is of material benefit when turnips are consumed. Perhaps this root may be cultivated with greater advantage than ruta бага upon many soils, as the precariousness of ruta бага has been acknowledged by almost every one who has treated upon the subject. It requires soil of the best quality, and a large dose of rich dung, to insure even a middling crop of ruta бага; therefore it can never be generally nor profitably cultivated by common farmers. On the other hand, yams present every advantage which can be got from ruta бага, and are not so pettish in their growth. Their culture is a matter of far less difficulty, as they will grow upon soils where ruta бага would starve. They require less manure, and may be planted as late in the season as the other, thereby enabling the farmer to bestow the like previous preparation upon the ground, the want of which is a general argument against ordinary potatoe husbandry. By taking them up in October or November, they may be safely housed, and the ground directly ridged up and sown with wheat. (*Brown.*)

4831. *The value of potatoes as a fallow crop*, and as an article of food for cattle compared with turnips and cabbages for the same purposes, Marshal observes, may be considered thus: Potatoes are more nutritious; and, in the opinion of those who have used them, fatten cattle much quicker than either turnips or cabbages. Potatoes, too, being secured from the severities of winter, are a more certain article of fattening than turnips or cabbages; both of which are liable to perish under an alternancy of frost and thaw; and the turnip, more particularly, is locked up, or rendered more difficult to be come at, during a continuance of snow or frost. Turnips and cabbages, if they out-weather the severities of winter, occupy the soil in the spring when it is wanted to be prepared for the succeeding crop; while potatoes, if properly laid up, are a food which may be continued without inconveniency until the cattle be finished, or the grass has acquired the requisite bite for finishing them in the field. On the other hand, potatoes are a disagreeable crop to cultivate: the planting is a tedious dirty business; and taking them up, may be called the filthiest work of husbandry, especially in a wet autumn. A powerful argument for the extensive culture of potatoes as food for live-stock is, that in seasons of scarcity they can be adopted as human food. Here, as in many other points, the opinion of Marshal and other English agriculturists, is rather at variance with that of the Northumberland and Berwickshire cultivators.

4832. *The varieties of the potatoe* are innumerable: they differ in their leaves and bulk of haulm; in the color of the skin of the tubers; in the color of the interior compared with that of the skin; in the time of ripening; in being farinaceous, glutenous, or watery; in tasting agreeably or disagreeably; in cooking readily or tediously; in the length of the subterraneous stolones to which the tubers are attached; in blossoming or not blossoming; and, finally, in the soil which they prefer.

4833. *The earliest varieties of the potatoe* are chiefly cultivated in gardens, and therefore we shall only notice such early sorts as are grown in the fields. These are —

The early kidney,  
The nonsuch,

The early shaw, and  
The early champion.

The last is the most generally cultivated round London; it is very prolific, hardy, and mealy. Early varieties, with local names, are cultivated near most large towns, especially Manchester, Liverpool, Glasgow, Edinburgh, and the metropolis.

4834. *The late field varieties in most repute are —*

The red-nose kidney.

Large kidney.

Bread fruit, raised in 1810, from seed, and esteemed one of the best field potatoes; being white, mealy, well tasted, and prolific.

Lancashire pink eye, good.

Black skin, white interior, and good.

Purple, very mealy, productive, and keeps well.

Red apple, mealy, keeps the longest of any.

Tartan, or purple and white skinned, an esteemed Scotch potatoe, prolific, mealy, exceedingly well tasted, and keeps well.

4835. *The varieties grown exclusively as food for live-stock are —*

The yam or Surinam potatoe; large, red and white skinned, and the interior veined with red; flavor disagreeable, and not such as to admit of its being used as human food. It succeeds best on heavy lands.

The ox noble; large, yellow without and within, very prolific, not fit to eat.

The late champion; large and prolific, white skinned, and may be used as human food.

4836. *New varieties of potatoes are procured with the greatest ease. The following directions are given in a useful work on this plant. Pluck off the apples when the stalk has ceased to vegetate and is drying up. The seed being then fully ripe, break the apple in a hair sieve, wash the pulp clean from the seeds, and dry them in the sun; then sow the seed in beds in March, and take the potatoes up in October. They will attain the size of nutmegs, or at most be no larger than walnuts. Select the fairest and best, and keep them secure from frost by thoroughly drying, and intermixing, and covering them with sifted wood or coal-ashes. Plant them in April following, at the distance of fifteen inches asunder; and when the plant is two inches high, hill them with fresh earth. This may be done several times, constantly taking care to keep them clean from weeds. Observe when the stalks decay; some will be found decaying much sooner than others; these are the early kind, but those that decay last are the sort which comes late. Take them up in rotation as they ripen, and let the produce of each potatoe be kept separate till the next year. Such as come early, may be tried as soon as they are taken up, by dressing one or two; should they be approved, the remainder may be preserved; but those which are late should not be tried before January or February, for it will be found that the late kind of potatoes, newly raised, are very soft, and cut like soap, until they have been hoarded a certain time, when they become mealy. Under each stalk you may expect to find a gallon of potatoes. Those planted the third year may, perhaps, produce two sacks; and their increase afterwards will be very considerably greater. Thus it takes full three years to form an adequate judgment of potatoes raised from seed, and, after all, if one in ten succeed so as to be worth preserving, it is as much as can be reasonably expected.*

4837. *Some of the earlier sorts of potatoes do not blossom, and consequently do not, under ordinary management, produce seeds. To procure blossoms and seeds from these, it is necessary, from time to time, during the early part of the summer, to remove the earth from the roots of the plants, and pick off the tubers, or potatoes as they begin to form. By thus preventing the strength of the plant from being employed in forming tubers at the root, it will flow into the leaves and herbage, and produces blossoms and apples. Knight, the president of the Horticultural Society, by adopting this practice, succeeded in procuring seeds from some sorts of potatoes, which had never before produced blossoms; and from these seeds he raised excellent varieties, some hardy and less early, others small and very early. He farther impregnated the blossoms produced by these early potatoes with other sorts, some early and some late (in the way in which graziers cross the breeds of cattle to improve the offspring), and he succeeded in producing varieties, more early than late sorts, and more hardy and prolific than any early potatoes he had seen. These he cultivated in his fields, deeming them preferable to all other sorts as admitting of later planting and earlier removal, and this practice he justly considered as highly favorable to the succeeding crop of wheat.*

4838. *In choosing a sort or sorts of potatoes from the numerous varieties which are to be found every where, perhaps the best way is, for the selector to procure samples and taste them, and to fix on what best pleases his palate. The shaw is one of the best early potatoes for general field culture; and the kidney and bread-fruit are good sorts to come in in succession. The Lancashire pink is also an excellent potatoe, and we have never in any part of the British isles tasted a potatoe equal in mealiness and flavor to this variety, as cultivated round Prescot, near Liverpool. The red apple and tartan are of undoubted preference as late or long keeping potatoes. The yam is decidedly the best potatoe for stock, and will produce from twelve to fifteen tons per acre.*

4839. *The soil in which the potatoe thrives best is a light loam, neither too dry nor too moist, but if rich, it is so much the better. They may, however, be grown well on many other sorts of lands, especially those of the mossy, moory, and other similar kinds, where they are free from stagnant moisture, and have had their parts well broken down by culture, and a reasonable portion of manure added. The best flavored table potatoes are almost always produced from a newly broken up pasture ground not manured; or from any new soil, as the site of a grubbed up copse or hedge, or the site of old buildings or roads. Repeated on the same soil they very generally lose their flavor. The yam produces the largest crops on a loamy and rather strong soil, though it will grow well on any that is deep ploughed and well manured.*

4840. *In preparing the soil for potatoes*, it is of much importance to free it as completely as possible from weed roots, which cannot be so well extirpated afterwards, as in the culture of turnips, and some other drilled crops, both because the horse-hoe must be excluded altogether at a time when vegetation is still vigorous, and because at no period of their growth is it safe to work so near the plants, especially after they have made some progress in growth. It is the earlier time of planting, and of finishing the after-culture, that renders potatoes a very indifferent substitute for fallow, and in this respect in no degree comparable to turnips. For this reason, as well as on account of the great quantity of manure required, their small value at a distance from large towns, and the great expense of transporting so bulky a commodity, the culture of potatoes is by no means extensive in the best managed districts. Unless in the immediate vicinity of such towns, or in very populous manufacturing counties, potatoes do not constitute a regular rotation crop, though they are raised almost every where to the extent required for the consumption of the farmer and his servants, and, in some cases, for occasionally feeding horses and cattle, particularly late in spring. The first ploughing is given soon after harvest, and a second, and commonly a third, early in spring; the land is then laid up into ridgelets, from twenty-seven to thirty inches broad, as for turnips, and manured in the same manner.

4841. *The best manure for the potatoe* appears to be littery farm-yard dung; and the best mode of applying it immediately under the potatoe sets. Any manure, however, may be applied, and no plant will bear a larger dose of it, or thrive in coarser or less prepared manure: even dry straw, rushes, or spray of trees, may be made use of with success. It is alleged, however, that recent horse manure, salt, and soapers ashes, have a tendency to give potatoes a rank taste, and to render them scabby.

4842. *The best climate for the potatoe* is one rather moist than dry, and temperate or cool, rather than hot. Hence the excellence of the Irish potatoes, which grow in a dry loamy calcareous soil and moist and temperate climate: and hence, also, the inferiority of the potatoes of France, Spain, and Italy, and even Germany. In short, the potatoe is grown no where in the world to the same degree of perfection as in Ireland and Lancashire, and not even in the south of England so well as in Scotland, and the north and western counties: all which is, in our opinion, clearly attributable to the climate.

4843. *The season for planting* early potatoes in the fields, depends much on the soil. Where this is very dry, as it always ought to be for an early crop, the sets may be put in the ground in March or earlier; but for a full crop of potatoes, April is the best time for planting. Potatoes, indeed, are often planted in the end of May, and sometimes even in June; but the crops, although often as abundant, are neither so mellow nor mature, as when the sets are planted in April, or in the first eight or ten days of May.

4844. *In preparing the sets of potatoes*, some cultivators recommend large sets, others small potatoes entire, and some large potatoes entire. Others, on the ground of experience, are equally strenuous in support of small cuttings, sprouts, shoots, or even only the eyes or buds. With all these different sorts of sets, good crops are stated to have been raised, though tolerable sized cuttings of pretty large potatoes, with two or three good eyes or buds in each, are probably to be preferred. Independent of the increased expense of the seed, it is never a good practice to make use of whole potatoes as sets. The best cultivators in Ireland and Scotland invariably cut the largest and best potatoes into sets, rejecting in the case of kidney potatoes the root or mealy end as having no bud, and the top or watery end as having too many. No objection is made to two or even three buds on each set, though one is considered as sufficient. A very slight exercise of common sense might have saved the advocates for shoots, scooped out eyes, &c. their experiments and arguments, it being evident, as Brown has observed, to every one that has any practical knowledge of the nature of vegetables, that the strength of the stem at the outset depends in direct proportion upon the vigor and power of the set. The set, therefore, ought to be large, rarely smaller than the fourth part of the potatoe; and if the set is of small size, one half of the potatoe may be profitably used. At all events, rather err in giving over large sets, than in making them too small; because by the first error, no great loss can be sustained; whereas, by the other, a feeble and late crop may be the consequence.

4845. *The time for cutting the sets* should always be some days before planting, that the wounds may dry up; but no harm will result from performing this operation several weeks or months beforehand, provided the sets are not exposed too much to the drought so as to deprive them of their natural moisture.

4846. *The quantity of sets* depends on the size of the potatoes; in general where the sets are sufficiently large from eight to ten cwt. will be required for an acre: more than ten for yams, and fewer than eight cwt. for the early nonsuch and ash-leaved.

4847. *The modes of planting* the potatoe are various. Where spade culture is employed, they are very frequently planted on beds (provincially lazy-beds), of four or six



feet wide, with a trench or gutter between a foot or eighteen inches in width, and which supplies soil for earthing up the potatoes. This is the rudest mode of planting and cultivating potatoes, and unworthy of being imitated either on a farm or garden. The next mode is planting on a plain surface, either with or without manure, according to the state of the soil. Here the sets are placed in rows at from eighteen inches to two and a half feet distance between the rows, according to the kind of potatoe, and from four to nine inches distant in the rows. In planting, a hole for each set is made by a man with a spade, while a woman or boy drops the set, and the earth is replaced; or the potatoe dibber is used, and the ground afterwards slightly harrowed. Another mode of planting on a plain surface, when the soil is inclined to be dry, is in some cases practised, which is, after the land has been brought into a proper condition by ploughing over twice or oftener and well harrowed, to spread the manure regularly over the whole surface, the sets being planted in every third furrow, and the dung with the fine earth turned upon them by the next furrow of the plough. In this way the manure is however placed upon the sets, which has on experiment been fully shown to be injurious to the produce. Besides, from the whole of the surface of the ground being covered with dung, a considerably larger proportion must be requisite than when deposited only in the drills, and of course the crop cannot be cultivated to advantage in that respect.

4848. *In planting the potatoe on sward land*, after it has been prepared by the use of a plough that just pares off the surface and deposits it in the furrow, it is advised by Somerville to place the sets upon the inverted sod, and cover them with the loose mould from below by means of a common plough; or the trench plough may be used with perhaps more advantage: but a better method is that of paring and burning. In some cases the practice is, however, to turn down the turf with or without manure, and then to put in the sets by a dibble; though the former is probably the better practice, as the turfy material on which the sets are put soon begins to decay, and the purpose of a manure is in some measure answered by it. It is a plan that may be adopted with advantage where manure is scarce, as in bringing waste and other coarse grass lands into the state of preparation for grain crops.

4849. *A mode of planting potatoes and at the same time trenching the land*, is practised in Lancashire, and in some districts in the north-east of Scotland. The farmer having carried the dung, and laid it on the field in heaps, at proper distances, the operation is performed by the manufacturers and people who rent the field, and in the following manner: Across the end of the ridge, a trench is formed, about three feet wide, and from ten to fourteen inches deep, according to the depth and quality of the subsoil. That being done, a second trench of the same breadth is marked off, and the surface-soil, to the depth of six or eight inches, is thrown into the bottom of the former trench, over which a sufficient quantity of dung being laid, the potatoes are planted at the distance of eight or ten inches from each other, and then as much earth is taken from the bottom of the second trench, as is necessary for covering the potatoe-sets, and of making up the first trench to its former level. Thus the field being completely trenched, well manured, and kept thoroughly clean by repeated hand-hoings, must not only produce an abundant crop of potatoes, but also be in high condition for receiving whatever kind of seed may be afterwards sown.

4850. *The mode of planting potatoes by the best farmers of the northern districts*, is in drills formed by the plough in the same manner as in preparing the land for turnips. The soil is laid up into ridgelets from twenty-seven to thirty inches broad, the manure is distributed between them, and on this manure the sets are placed from four to eight inches asunder: they are then covered by reversing the ridgelets.

4851. *The planting of early potatoes* is carried to a very high degree of perfection in Lancashire. It is stated in *The Lancashire Agricultural Report*, in respect to the raising of seed potatoes, that upon the same ground from which a crop has already been taken, the early seed potatoes are in some places afterwards planted; which, after being got up about November, are immediately cut up into sets, and preserved in oat husks or saw-dust, where they remain till March, when they are planted, after having had one spit taken off, and planted with another, of a length sufficient to appear above ground in the space of a week. But the most approved method is, to cut the sets, and put them on a room-floor, where a strong current of air can be introduced at pleasure, the sets laid thinner, as about two layers in depth, and covered with the like materials (chaff or saw-dust) about two inches thick: this screens them from the winter frosts, and keeps them moderately warm, causing them to vegetate; but at the same time admits air to strengthen them, and harden their shoots, which the cultivators improve by opening the doors and windows on every opportunity afforded by mild soft weather: they frequently examine them, and when the shoots are sprung an inch and a half, or two inches, they carefully remove one half of their covering, with a wooden rake, or with the hands, taking care not to disturb

or break the shoots. Light is requisite as well as air, to strengthen and establish the shoots; on which account a green-house has the advantage of a room, but a room answers very well with a good window or two in it, and if to the sun still better. In this manner they suffer them to remain till the planting season, giving them all the air possible by the doors and windows, when it can be done with safety from frost: by this method the shoots at the top become green, leaves are sprung, and are moderately hardy. They then plant them in rows, in the usual method, by a setting-stick; and carefully fill up the cavities made by the setting-stick; by this method they are enabled to bear a little frost without injury. The earliest potatoe is the superfine white kidney; from this sort, upon the same ground, have been raised four crops; having sets from the repository ready to put in as soon as the other were taken up; and a fifth crop is sometimes raised from the same lands, the same year, of transplanted winter lettuce. The first crop had the advantage of a covering in frosty nights. It is remarked that this useful information was communicated by J. Blundell, Ormskirk, and has hitherto been known only among a very few farmers.

4852. *The after culture of potatoes consists in harrowing, hoeing, weeding, and earthing up.* All potatoes require to be earthed up, that is, to have at least one inch in depth of earth heaped on their roots, and extending six or eight inches round their stem. The reason of this is, that the tubers do not, properly speaking, grow under the soil, but rather on, or just, partially, bedded in its surface. A coating of earth, therefore, is found, by preserving a congenial moisture, greatly to promote their growth and magnitude, as well as to improve their quality, by preventing the potatoes from becoming green on the side next the light. The earth may be thrown up from the trenches between the beds by the spade; or, where the potatoes are planted in rows, the operation may be performed with a small plough, drawn by one horse, or by the hoe. In Scotland, where the potatoe is extensively cultivated by the farmer, as food for cattle as well as man, the plough is universally used. In Ireland, where the bed, or lazy-bed manner is adopted, the earth is thrown up from the intervening trenches. The hoe is generally used by market-gardeners.

4853. *The after culture, where potatoes are planted in ridgelets, as above described (4850.), commences when the plants begin to rise above the surface.* They are then harrowed across, and afterwards the horse-hoe, or small hoeing plough, and the hand-hoe, are repeatedly employed in the intervals, and between the plants, as long as the progress of the crop will permit, or the state of the soil may require. The earth is then gathered once, or oftener, from the middle of the intervals towards the roots of the plants, after which any weeds that may be left must be drawn out by hand; for when the radicles have extended far in search of food, and the young roots begin to form, neither the horse nor hand-hoe can be admitted without injury.

4854. *The after culture adopted in some parts of Devonshire is somewhat singular and deserves to be noticed.* The sets are there generally cut with three eyes and deposited at the depth of three inches with the spade or dibber; when the first shoot is three inches high, prepare a harrow with thorns interwoven between the tines, and harrow the ground over till all the weeds are destroyed, and not a shoot of the potatoes left. It may seem strange that such an apparent destruction of a crop should cause an increase; but it may be affirmed as an incontestible fact, that by this means the produce becomes more abundant. The reason appears to be this; although three eyes are left to a piece of potatoe, one always vegetates before the others, and the first shoot is always single; that being broken off, there is for the present a cessation of vegetation. The other eyes then begin to vegetate, and there appear fresh shoots from the broken eye; so that the vegetation is trebled, the earth made loose, and the lateral shoots more freely expanded. If these bints are observed, the produce of potatoes, it is said, will exceed a fifth of the crop obtained by the usual mode of cultivation.

4855. *Pinching off the whole of the potatoe blossoms is a part of after culture not unworthy the attention of the farmer.* This may at first sight appear too minute a matter to enter into the economy of farm management. But when it is considered that the seed is the essential part of every plant, and that to which the ultimate efforts of nature are always directed, it will be allowed that an important part of the nourishment of every vegetable must be devoted for this purpose. In the case of the potatoe, every person knows that the weight of the potatoe-apples, grown by a single plant, is very considerable. Now we have seen (4837.) that apples may be produced instead of tubers in early potatoes, from whence it may justly be inferred, that more tubers may be produced in late ones by preventing the growth of the apples. Such was the reasoning of Knight, and by repeatedly making the experiment, he came to this conclusion, that in ordinary cases of field culture, by pinching off the blossoms of late crops of potatoes, more than one ton per acre of additional tubers will be produced. The experiments are related in the second volume of *The Horticultural Transactions*, and the practice is similar to one

common among the growers of bulbous roots in Holland, as alluded to by Dr. Darwin, who also recommends its application to the potatoe. A woman, or boy, will crop the blossoms from an acre of potatoes in a day, or even in less time where the crop is not excessively luxuriant.

4856. *The taking of the crop of potatoes* is on a small scale generally performed with the spade or three pronged fork; but under judicious farm management and the row culture by the common plough. The coulter is removed and the plough goes first along one side of all the ridgelets of a ridge, or any convenient breadth, and then, when the potatoes so brought to view are gathered by women placed at proper distances, it returns and goes along the other side. When the land is somewhat moist, or of a tenacious quality, the furrow-slice does not give out the roots freely, and a harrow which follows the plough is commonly employed to break it and separate them from the mould. Various contrivances have been resorted to for this purpose. A circular harrow or break to be attached to the plough, of very recent invention, has been found to answer the purpose well, and to effect a considerable saving of labor.

4857. *A mode of taking part of a crop* suited to cottagers and others, especially in years of scarcity, deserves to be mentioned. Having ascertained that some of the tubers have attained an eatable size, go along the rows and loosen the earth about each plant with a blunt stick, taking two or three of the largest tubers from each and returning the earth carefully. By this means both an early supply, and the advantage of two crops, may be obtained; for the tubers which remain will increase in size, having now the nourishment destined to complete the growth of those removed.

4858. *Potatoes intended for seed* should be taken up a fortnight or three weeks before fully ripe, for reasons that will be given in treating of the diseases of this plant. The ill shaped, small, bruised, or diseased tubers, should be laid aside, and the fairest and best dried in the sun, and spread on a cellar or loft floor, and covered with ashes or chaff of sufficient thickness to keep out the frost. In this state they may remain till wanted for cutting.

4859. *Potatoes are stored and preserved* in houses, cellars, pits, pies, and camps. Whatever mode is adopted, it is essential that the tubers be perfectly dry, otherwise they are certain of rotting, and a few rotten potatoes will contaminate a whole mass. Putting them into close houses, and covering them well up with dry straw, is the most effectual mode, and that which is generally adopted. In some parts of Scotland it is a common practice to dig pits in the potatoe-field, when the soil is dry and light, and, putting in potatoes to the depth of three or four feet, to lay a little dry straw over them, and then cover them up with earth, so deep that no frosts can affect them. Another method, which is practised in England as well as Scotland, is to put them together in heaps, and cover them up with straw, in the manner of preserving turnips, with this addition, that the heaps are afterwards well covered with earth, and so closely packed together as to exclude frost. The farmers in Lancashire sort and separate their potatoes in the course of taking them up according to their sizes, and are particularly careful to throw aside all those that are spoiled before raising, or that are cut in the taking up. This is a very necessary and proper precaution (although by no means generally attended to), as the crop must have a much better chance for keeping, than when diseased or cut potatoes are stored up with it. It is also of great advantage to have the work performed in a dry season, as the potatoes seldom keep well when taken up wet, or when placed in any sort of repository for keeping while in that state.

4860. *But the best way of storing potatoes*, Young says, is in what are called potatoe-pies. A trench, one foot deep and six wide, is dug, and the earth clean shovelled out, and laid on one side, this has a bedding of straw, and the one-horse carts shoot down the potatoes into the trench; women pile them up about three feet high, in the shape of a house roof; straw is then carefully laid on six or eight inches thick, and covered with earth a foot thick, neatly smoothed by flat strokes of the spade. In this method he never lost any by the severest frosts; but in cases of its freezing with uncommon severity, another coat of straw over all gives absolute security. These pies when opened, should each be quite cleared, or they are liable to depredation. To receive one at a time, besides also being at first filled for immediate use, he has a house that holds about 700 bushels, formed of posts from fir plantations, with wattled sides, then a layer of straw, and against that earth six feet thick at the bottom and eighteen inches at top; the roof flat, with a stack of beans upon it. This he has found frost tight. The beans keep out the weather, he says, and yet admit any steam which rises from the roots, which, if it did not escape, would rot them.

4861. *Several other modes of preserving potatoes* are in use in different places. In Rutlandshire, Marshal says, the method of laying up potatoes is universally that of camping them; a method somewhat similar to the above, but which requires to be described. Camps are shallow pits, filled and ridged up as a roof with potatoes; which are covered up with the excavated mould of the pit. This is a happy mean, he thinks, between bury-

ing them in deep pits, and laying them upon the surface. Camps are of various sizes; being too frequently made in a long square form like a corn-rick, and of a size proportioned to the quantity to be laid up. It has, however, been found by experience, that when the quantity is large, they are liable to heat and spoil; much damage having sometimes been sustained by this imprudence. Experienced campers hold that a camp should not be more than three feet wide; four feet is perhaps as wide as it can be made with propriety, proportioning the length to the quantity; or, if this be very large, forming a range of short ones by the side of each other. The usual depth is a foot. The bottom of the trench being bedded with dry straw, the potatoes are deposited, ridging them up as in measuring them with a bushel. On each side the roof long wheat straw is laid, neatly and evenly as thatch; and over this the mould raised out of the trench, is evenly spread; making the surface firm and smooth with the back of the spade. A coat of coal ashes is sometimes spread over the mould, as a still better guard against frost. It is needless to observe that a camp should have a dry situation; and that the roots ought to be deposited in as dry a state as possible. These camps are tapped at the end, some bavons, or a quantity of loose straw being thrust close in the opened end, as a bung or safeguard. As it is a matter of the highest importance to preserve this root without spoiling during the whole year, it has been suggested, that the best method yet discovered for keeping potatoes sound for the longest period, is to spread them on a dry floor early in the spring, and to rub off the eyes occasionally, as they appear to have a tendency to push out; by using these precautions, Donaldson has frequently seen potatoes kept in good condition till the month of June.

4862. *In Canada and Russia* the potatoe is preserved in boxes in houses or cellars heated to a certain temperature by stoves. (*Farm. Mag.* vol. xx. p. 449.)

4863. *To keep potatoes any length of time*, the most effectual way is to place them in thin layers on a platform suspended in an ice cellar. There the temperature being always below that of active vegetation they will not sprout, while not being many degrees below the freezing point the tubers will not be frost bit. Another mode is to scoop out the eyes by a very small scoop, and keep the roots buried in earth. A third mode is to destroy the vital principle by kiln drying, steaming, or scalding.

4864. *The produce of the potatoe* varies from five to eight, and sometimes ten or twelve tons per acre; the greatest produce is from the yam, which has been known to produce twelve tons or 480 bushels per acre. The haulm is of no use but as manure, and is very generally burned for that purpose, being slow of rotting.

4865. *The application of the potatoe crop* of the greatest importance is as human food, on which it is unnecessary to enlarge. Einhoff found mealy potatoes to contain twenty-four per cent. of their weight of nutritive matter, and rye seventy parts. Consequently sixty-four and a half measures of potatoes afford the same nourishment as twenty-four measures of rye. A thousand parts of potatoe yielded to Sir H. Davy from 200 to 260 parts of nutritive matter, of which from 155 to 200 were mucilage or starch, fifteen to twenty sugar, and thirty to forty gluten. Now, supposing an acre of potatoes to weigh nine tons, and one of wheat one ton, which is about the usual proportion, then as 1000 parts of wheat afford 950 nutritive parts, and 1000 of potatoe say 230, the quantity of nutritive matter afforded by an acre of wheat and potatoes will be nearly as nine to four; so that an acre of potatoes will supply more than double the quantity of human food afforded by an acre of wheat. The potatoe is perhaps the only root grown in Britain which may be eaten every day in the year without satiating the palate, and the same thing can only be said of the West India yam, and bread fruit. They are, therefore, the only substitute that can be used for bread with any degree of success, and indeed they often enter largely into the composition of the best loaf bread without at all injuring either its nutritive qualities or flavor. (*Edin. Encyc. art Baking.*) In the answer by Dr. Tissot to M. Liqueur, the former objects to the constant use of potatoes as food, not because they are pernicious to the body, but because they hurt the faculties of the mind. He owns that those who eat maize, potatoes, or even millet may grow tall and acquire a large size; but doubts if any such ever produced a literary work of merit. It does not, however, by any means appear that the very general use of potatoes in our own country has at all impaired either the health of body or vigor of mind of its inhabitants.

4866. *The meal of potatoes* may be preserved for years closely packed in barrels, or unground in the form of slices; these slices having been previously cooked or dried by steam, as originally suggested by Forsyth, of Edinburgh. (*Encyc. Brit.*) Some German philosophers have also proposed to freeze the potatoe, by which the feculous matter is separated from the starch, and the latter being then dried and compressed, may be preserved for any length of time, or exported with ease to any distance. (*Annalen des Ackerbaues*, vol. iii. s. 389.)

4867. *The ordinary economical applications* of the potatoe, next to those of the culinary and baking arts, is in starch making and the distillery. Starch is readily made from the

scraped and washed tubers cut into small pieces and steeped in water; and a spirit is distilled from mashed potatoes fermented, so as to change a portion of the starch into sugar. In general it is found that three and a half bushels of potatoes afford the same quantity of spirit as one of malt.

4868. *Among extraordinary applications of the potatoe*, may be mentioned cleaning woollens, and making wine and ardent spirit.

4869. *Cleaning woollens*. The refuse of potatoes used in making starch when taken from the sieve, possesses the property of cleansing woollen cloths, without hurting their color; and the water decanted from the starch powder is excellent for cleansing silks, without the smallest injury to the color.

4870. *Wine*, of considerable quality, may be made from frosted potatoes, if not so much frosted as to have become soft and waterish. The potatoes must be crushed or bruised with a mallet, or put into a cider press. A bushel must have ten gallons of water, prepared by boiling it, mixed with half a pound of hops, and half a pound of common white ginger. This water, after having boiled for about half an hour, must be poured upon the bruised potatoes, into a tub or vessel suited to the quantity to be made. After standing in this mixed state for three days, yeast must be added to ferment the liquor. When the fermentation has subsided, the liquor must be drawn off, as fine as possible, into a cask, adding half a pound of raw sugar for every gallon. After it has remained in the cask for three months, it will be ready for use.

4871. *Ardent spirit*. Potatoes that have been injured by the frost, produce a much greater quantity of spirit, and of a much finer quality than those that are fresh; they require a proportion of malt-wash to promote the fermentation. About one-fourth part of malt-worts, or wash, ought to be fermented at least six hours before the potatoe wash is joined to it; otherwise the potatoe wash having an aptitude to ferment, will be ripe for the still before the malt-wash is ready; hence the effect will be, to generate an acid which renders the spirit coarse, and, when diluted with water, of a milky or bluish color. When the spirit is strong, the acid is held in solution; but appears as above, when diluted with water. (*Farmer's Mag.* vol. xvii. p. 325.)

4872. *In the application of potatoes as food for live-stock*, they are often joined with hay, straw, chaff, and other similar matters, and have been found useful in many cases, especially in the later winter months, as food for horses, cows, and other sorts of live-stock. With these substances, as well as in combination with other materials, as bean or barley-meal and pollard, they are used in the fattening of neat cattle, sheep and hogs. Potatoes are much more nutritive when boiled; they were formerly cooked in this way, but are now very generally steamed, especially in the north. The practice has been carried to the greatest extent by Curwen in feeding horses. He gives to each horse, daily, one and a half stone of potatoes mixed with a tenth of cut straw. One hundred and twenty stones of potatoes require two and a quarter bushels of coals to steam them. An acre of potatoes, he considers, goes as far in this way as four of hay. Von Thaer found them, when given to live-stock, produce more manure than any other food: 100 lbs. of potatoes producing 66 lbs. of manure of the very best description. The baking of potatoes in an oven has also been tried with success. (*Comm. Board of Agriculture*, vol. iv.); but the process seems too expensive. They are also given raw to stock of every description, to horses and hogs washed, but not washed to cows or oxen. Washing was formerly a disagreeable and tedious business, but is now rendered an easy matter, whether on a large or small scale, by the use of the washing machine.

4873. *Frosted potatoes* may be applied to various useful purposes, for food by thawing in cold water, or being pared, then thawed and boiled with a little salt. Salt, or saltpetre, chaff, or bruised oats, boiled with them, will render them fit food for cattle, swine, poultry, &c. Starch, and paste for weavers, bookbinders, and shoemakers, may be made from them when too sweet to be rendered palatable, and also an ardent spirit, from hydrometer proof to 10 per cent. over proof.

4874. *The diseases of the potatoe* are chiefly the scab, the worm, and curl. The scab, or ulcerated surface of the tubers, has never been satisfactorily accounted for. Some attributing it to the ammonia of horse-dung, others to alkali, and some to the use of coal ashes. Change of seed, and of ground, are the only resources known at present for this malady. The worm and grub both attack the tuber, and the same preventative is recommended. The only serious disease of the potatoe is the curl, and this is now ascertained to be produced by the too great concentration of the sap in the tuber, and this concentration, or thickening, is prevented by early taking up. This discovery was first made by the farmers near Edinburgh observing that seed potatoes procured from the moors, or elevated cold ground, in the internal parts of the country, never suffered from the curl, and it consequently became a practice, every three or four years, to procure a change of seed from these districts. On enquiry, it was found, that the potatoes in these upland grounds continued in a growing state till the haulm was blackened by the first frosts of October. They were then taken up, when, of course, they could not

be ripe. Subsequent experiments, which will be found detailed in *The Farmer's Magazine*, and *Caledonian* and *London Horticultural Transactions*, have firmly established the fact, that the curl is prevented by using unripe seed, therefore the farmer ought to select his seed stock a fortnight or three weeks before he takes up the general crop, as already recommended. It is also a safe practice frequently to change the seed, and also to change the variety.

4875. *Sheriff*, an ingenious speculator and yet practical agriculturist, is of opinion that there are only two causes for the curled disorder in potatoes. The first is excessive seed bearing, that is, carrying great quantities of plums or apples; from the effects of which, if the plant be not too far advanced in life, it may recover for a time, by removing it to a shady or upland situation. The second cause is time or old age, which never fails ultimately to bring the curled or shrivelled disorder, followed by death, on the whole animal and vegetable kingdoms. An old decaying oak is an instance of the curled or shrivelled state of trees from age, as is "the lean and slippered pantaloon" of the curled disorder from old age in the human species. An apple tree, again, that has carried extraordinary crops of fruit within a few years, is often in the state of a potatoe curled from excessive apple bearing; so is a hart, or a buck, immediately after the rutting season. Both the tree and animals will recover their health and vigor for a time, unless they are too old, or have gone to the very greatest and last extremity in seed bearing and ventry, in which cases the effects will be the same as those of time, viz. death. It is not then to over-ripening the tubers that the curled disorder in potatoes is to be attributed, but to time and seed-bearing, that is, carrying great quantities of plums or apples.

SECT. II. *The Turnip*. — *Brassica Rapa*, L. *Tetrad. Siliq.* L. and *Crucifereæ*, J. *Rave*, Fr.; *Rübe*, Ger.; and *Rapa*. Ital.

4876. *The turnip* is a native of Britain, but in its wild state is not to be recognized by ordinary observations from wild mustard. It was cultivated as food for cattle by the Romans; and has been sown for the same purpose in the fields of Germany and the low countries from time immemorial. When they were introduced in this country, as a field plant, is unknown; but it is probable turnips would be found in some gardens of convents from the time of the Romans; and it is certain that they were in field culture before the middle of the seventeenth century, though then, and for a long time afterwards, in a very inferior and ineffectual manner. It has been stated that turnips were introduced from Hanover in George I.'s time; but so far from this having been the case, George II. caused an abstract of the Norfolk system of turnip husbandry to be drawn up for the use of his subjects in Hanover. (*Campbell's Polit. Survey*, &c. vol. iii, p. 80.) The introduction of improved turnip culture into the husbandry of Britain, Brown observes, "occasioned one of those revolutions in rural art which are constantly occurring among husbandmen; and, though the revolution came on with slow and gradual steps, yet it may now be viewed as completely and thoroughly established. Before the introduction of this root, it was impossible to cultivate light soils successfully, or to devise suitable rotations for cropping them with advantage. It was likewise a difficult task to support live-stock through the winter and spring months; and as for feeding and preparing cattle and sheep for market during these inclement seasons, the practice was hardly thought of, and still more rarely attempted, unless where a full stock of hay was provided, which only happened in very few instances. The benefits derived from turnip husbandry are, therefore, of great magnitude. Light soils are now cultivated with profit and facility; abundance of food is provided for man and beast; the earth is turned to the uses for which it is physically calculated; and, by being suitably cleaned with this preparatory crop, a bed is provided for grass seeds, wherein they flourish and prosper with greater vigor than after any other preparation." (*Treatise on Rural Affairs*.)

4877. *Turnips and clover*, it is elsewhere observed, "are the two main pillars of the best courses of British husbandry; they have contributed more to preserve and augment the fertility of the soil for producing grain — to enlarge and improve our breeds of cattle and sheep — and to afford a regular supply of butcher's meat all the year, than any other crops; and they will probably be long found vastly superior, for extensive cultivation, to any of the rivals which have often been opposed to them in particular situations. Though turnips were long cultivated in Norfolk before they were known in the northern counties, yet it is an undoubted fact that their culture was first brought to perfection in Roxburghshire, Berwickshire, and Northumberland, and chiefly through the exertions of Dawson, of Frogden, in the first named county, and Bailey, of Chillingham, in the latter.

4878. *The varieties of turnip* grown by farmers may be arranged as whites and yellows.

4879. *Of white turnips*, by far the best and most generally cultivated, is the globe; but there are also the green topped, having the bulb tinged; greenish and purple topped, with the bulb reddish, which, though they do not produce so large a crop as the globe or oval, stand the winter better, and the red topped, it is said, will keep till February. The pudding, or tankard turnip, has a white bulb which rises from eight to twelve inches high, standing almost wholly above ground. It is less prolific than any of the others, and more liable to be attacked by frost.

4880. *Of yellow turnips*, there are the field yellow, which is more hardy than the globe, and answers well for succeeding that variety in spring; and the ruta бага, or Swedish

turnip, which may be preserved for consumption till June. The Siberian turnip has a bulb and a branchy top, but both of inferior quality. It is a hybrid between a white ruta бага and field cabbage, or between rape and cabbage.

4881. *New varieties* are obtained by selection and by counter impregnation; but in either case the greatest care is requisite to keep the plants at least a furlong from any others of the brassica tribe likely to flower at the same time, otherwise the progeny will certainly be hybridized.

4882. *The choice of sorts* may be considered as limited to the white globe, yellow, and Swedish, according as early, middling, or late supplies are wanted. No other varieties are grown by the best farmers.

4883. *In the choice of seed* the farmer must rely on the integrity of the seed-dealer, as it is impossible to discover from the grains whether they will turn out true to their kinds. Turnip-seed requires to be frequently changed; and the best is generally procured from Norfolk and Northumberland. The Norfolk seed, Forsyth observes, is sent to most parts of the kingdom, and even to Ireland; but after two years it degenerates; so that those who wish to have turnips in perfection, should procure it fresh every year from Norwich, and they will find their account in so doing. For, from its known reputation, many of the London seedsmen sell, under that character, seed raised in the vicinity of the metropolis, which is much inferior in quality.

4884. *Turnip-seed will grow of any age*, if it has been carefully preserved; that which is new comes up first, and therefore it is not a bad plan to mix new and old together, as a means of securing a braird against drought or the fly. Whether plants from new or old seed are most secure from the depredations of the fly, is perhaps a question which cannot be easily determined, even by experiments; for concomitant circumstances are frequently so much more operative and powerful as to render the difference between them, if there be any, imperceptible. It is, however, known to every practical man, that new seed vegetates several days before the old, and more vigorously; and it is equally well known that the healthy and vigorous plants escape the fly, when the stunted and sickly seldom or never escape it. Hence it would seem, that new seed, *cæteris paribus*, is more secure from the fly than old.

4885. *The soil* for turnips should always be of a light description. In favorable seasons very good crops may be raised on any soil; but from the difficulty of removing them, and the injury which the soil must sustain either in that operation, or in eating them on the spot with sheep, they never on such soils can be considered as beneficial to the farmer. Turnips cannot be advantageously cultivated on wet tenacious soils, but are grown on all comparatively dry soils under all the variations of our climate. On dry loams, and all soils of a looser texture, managed according to the best courses of cropping, they enter into the rotation to the extent of a fourth, a sixth, or an eighth part of the land in tillage; and even on clayey soils they are frequently cultivated, though on a smaller scale, to be eaten by cattle, for the purpose of augmenting and enriching the manure, into which the straw of corn is converted.

4886. *The climate* most desirable for the turnip is cool and temperate. This was long ago noticed by Pliny, and it is so obvious on the continent that it admits of no dispute. Von Thaer observes, that the turnips grown on the fields of Germany seldom exceed half a pound in weight, and that all his care could not raise one beyond fourteen pounds. In France and Italy they are still less. A rapid climate is equally disadvantageous to the turnip; and they are accordingly found of no size in Russia, Sweden, and many parts of North America. Even turnips grown in the southern counties of England, in the same excellent manner as in Northumberland, never equal the size of those grown in the latter county, or further north, or in Ireland.

4887. *In the preparation of the soil*, the first ploughing is given with a deep furrow soon after harvest, usually in the direction of the former ridges; though, if the soil be dry, it is of little consequence in what direction. As soon as the spring seed-time is over, a second ploughing is given across the former, and the harrows, and, if necessary the rollers, are then set to work to clean and pulverize the soil. All the weed-roots that are brought to the surface are carefully gathered into heaps, and either burnt on the ground, or carried off to form a compost, usually with lime. The land is then generally ploughed a third time, again harrowed well, sometimes also rolled, and the weed-roots picked out as before. Unless land is in a much worse state, in regard to cleanliness and pulverization, than it usually is after turnips have been some time a rotation crop, no more ploughings are necessary. It is next laid up in ridgelets, from twenty-seven to thirty inches wide, either with the common swing-plough, or one with two mould-boards, which forms two sides of a ridgelet at once. Well-rotted dung, at the rate of twelve or fifteen tons per acre, is then carried to the field, and dropped from the cart in the middle of three intervals, in such a quantity as may serve for that and the interval on each side of it. The dung is then divided equally among the three, by a person who goes before the spreaders, one of whom, for each interval, spreads it with a small three-pronged fork along the bottom. The plough immediately follows, and, reversing the ridgelets, forms new ones over the dung; and the drill-barrow, commonly one that sows two drills at once, drawn by one horse, deposits the seed as fast as the new drills are formed. This drill-machine is usually furnished with two small rollers; one

that goes before the sowing apparatus, and levels the pointed tops of the ridgelets, and another that follows for the purpose of compressing the soil and covering the seed. From the time the dung is carted to the ground, until the seed is deposited, the several operations should go on simultaneously; the dung is never allowed to lie uncovered to be dried by the sun and wind; and the new ridgelets are sown as soon as formed, that the seed may find moisture to accelerate its vegetation. (*Supp. Encyc. Brit. art. Agr.*)

4888. *Manure* may be considered as essential to turnips. Turnip-land, Brown observes, cannot be made too rich, for, in fact, the weight of the crop depends in a great measure upon its condition in this respect. Manure is sometimes applied to the crop which immediately precedes the turnips; but, to answer well in this way, the land must naturally be of an excellent quality. In other cases, where the land is in good order, it is laid on the stubble previous to the first ploughing. But generally the dung is laid on immediately before the seed is sown; the ground is formed into drills or ridges, and the manure spread in the intervals between them; the drills are then split by the plough, the earth on each side covers the dung, forms a drill where the interval formerly was, and furnishes a bed for the seed. These operations are now so well understood, that it is unnecessary to describe them more particularly. Farm-yard manure is the kind generally applied: it should be well rotted, and not less than twelve or fifteen tons allowed to each acre.

4889. *The time of sowing* the several varieties is somewhat different; the Swedish should be put in the earliest, and then the yellow, both of them in the month of May. But as these kinds are much less extensively cultivated than the globe, the month of June is the principal seed time; and after the first week of July a full crop is not to be expected in the northern parts of the island. But in the southern counties turnips are frequently sown in August after pease, wheat, or tares. The crop, however, is always light and only fit to be eaten down by sheep in spring, or to send their tops to market as greens. After a crop of hotspur pease sold green for the London market, the land is well cleared with the horse-hoe, and upon once ploughing, turnips are sown; and just before the young plants are observed to be cutting the ground, the field receives a light top-dressing of soot-ashes, or the most portable manure that can be conveniently procured. This dressing, upon frequent trial, has been found to have a very good effect in preserving the infant turnip plant from the deprivations of the fly.

4890. *The preparation of turnip-seed* for sowing, by steeping in the drainings of dung-hills and other similar matters, has been recommended as a likely mode to prevent the fly; but it is not found to have this effect, and is never followed. Sometimes the following mode of preparation is adopted; half new and half old seed are mixed together; then half is taken and steeped in water for three or four hours; afterwards both steeped and unsteeped seed are mixed and immediately sown. The object of this preparation is to obtain four different brairds or risings of the seed, which is supposed to give four chances of escaping the fly which attacks the infant plants, instead of one. Another mode is to join to the above radish-seed, new and old, steeped in the above manner, it being found that the fly prefers the radish to the turnip. The most common precaution, however, as to the fly, is to sow thick, or to mix the seed with soot, lime, or ashes.

4891. *The quantity of seed* is usually from two to three pounds per acre.

4892. *The mode of sowing* in all the best cultivated districts is on raised drills. Not only the broad-cast, but even rows on a flat surface are rejected by all who understand the culture of the turnip. This plant never does any good in the field till its roots reach the dung; and therefore the only mode to ensure a heavy crop, is to put the dung immediately beneath the row. This is only to be done by the ridgelet, or raised drill system, as already explained in treating of preparing the soil. The drill used may be either the hand-drill, which sows one row at a time, and is pushed along by a woman, or by the horse-drill, which sows two rows. The latter from its weight and breadth performs the work with greater accuracy, and much more effectually than can be done by any hand machine. So much has been written to prove the disadvantages of sowing broad-cast, and the benefits of the drill system, that the subject may be considered as settled in favor of the latter, even in the case of midsummer sowing after early pease gathered green.

4893. *The after culture* may, in some cases, require to commence with watering by Young's excellent machine (2564.), though this has by no means found its way among farmers, and is only likely to be occasionally necessary. Some commence by strewing soot or lime along the row to annoy the fly, or sharp sand, ashes, or barley awns, to ward off the slug. In general, however, these practices are confined to gardens or cultivators on a very small scale, and like many others they are much oftener talked of than put in practice. The turnip farmer, as soon as the plants have put forth the *rough leaf*, or sooner if annual weeds have got the start of them, runs a horse-hoe between the ridgelets and cuts up the weeds on each side, almost close to the rows of the turnip plants, clearing out the bottom of the interval at the same time. The hand-hoes are always set to work as



soon as possible after, and the plants are left about nine inches distant; the Swedish kind somewhat closer. If the ground has been well prepared, and the plants are allowed to get too large, three experienced hoers go over an acre a day. A few days after this, a small swing plough, drawn by one horse, enters the interval between the rows, and, taking a furrow-slice off each side, forms a smaller ridgelet in the middle. If the annuals still rise in great abundance, the horse-hoe may be employed again, otherwise the next operation is to go over them a second time with the hand-hoe, when the intermediate ridgelet is levelled. Sometimes a third hoeing must be given, but that is done very expeditiously. When no more manual labor is required, a small plough with two mould-boards is employed to lay up the earth to the sides of the plants, leaving the ridgelets of the same form as when sown, which finishes the process. Large fields throughout their whole extent, dressed in this manner, are left as clean and as pleasant to the eye as the best cultivated garden. The horse and hand-hoeing, in ordinary cases, may cost about fifteen shillings per acre. Where the soil is perfectly dry, and has been well prepared, the small plough has of late been laid aside by many farmers, and the space between the rows is kept clean by the horse and hand-hoe alone; but if the soil be either wet from springs, or so flat as not easily to part with surface water, it is still considered proper to earth up the roots as the concluding part of the process; and it is always useful to plough between the ridges when couch-grass and other weeds have not been completely picked out before the land was sown. The gathering of the weeds, the spreading of the dung, and the hand-hoeing, are almost always performed by women and boys and girls.

4894. *A summary of turnip culture in drills, is given in The Berwickshire Survey, by a copper-plate.* In this (fig.

567

567.) is first shown the ridgelets with the dung spread between (a), then the dung covered, and the drills formed (b); rolled and the seed sown (c); the young plants with the earth hoed away from them by a curved coulter hoe (d); the plants further advanced, covering the soil with their leaves, and enjoying the dung with their roots (e); and full grown, the leaves being cut off in November, to be eaten green, and the bulbs left for winter use. (f)

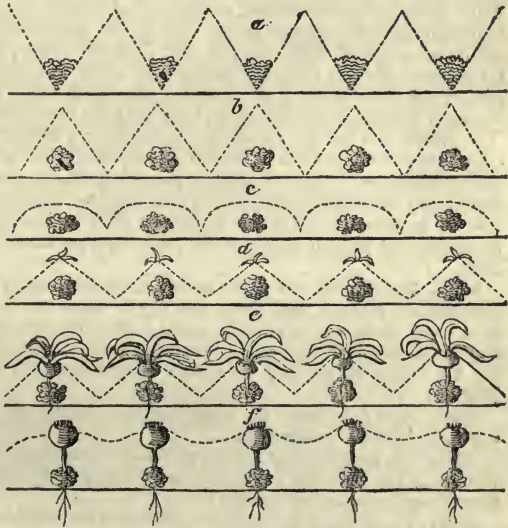

4895. *The turnip crop is generally taken and consumed at the same time.* They are consumed either on the spot where they grow; on grass-fields; in fold-yards; or in feeding-houses; but the far greater part, wherever they are extensively cultivated, by sheep. The price per acre when sold depends not only upon the weight of the crop, but also on the mode of its consumption.

4896. *When eaten by sheep in the place of their growth, turnips are lotted off, by means of hurdles or nets, that they may be regularly consumed.* When the first allowance is nearly eaten up, the bottoms or shells are picked out of the ground, by means of a two-pronged blunt hook adapted to the purpose; and then another portion of the field is taken in, by shifting the hurdles or nets, and so on regularly until the whole are finished; the cleared part of the field being usually left accessible as a drier bed for the sheep, and that they may pick up what shells remained when a new portion of the field was taken in.

4897. *The turnips required for other modes of consumption are usually drawn out, at regular intervals, before the sheep are put upon the field; unless the soil be so poor as to need all the benefit of their dung and treading, in which case, the whole are consumed where they grow; or so rich as to endanger the succeeding crops, by eating any part of the turnips on the ground.* In the latter very rare instance, the whole crop is carried to be consumed elsewhere, as must always be done, if the soil be naturally too wet for sheep feeding. In wet weather, when sheep ought not to be allowed to lie on the turnip field, it becomes necessary to carry the turnips to a grass field; and store sheep, not requiring to be so highly fed, frequently eat their turnips on such fields, as well as rear-

ing cattle, and sometimes milk cows. A grass field contiguous to the turnip one is always very desirable, that the sheep confined on other sides by hurdles or nets, may always find a dry place to lie on.

4898. In the *expenditure of turnips to young cattle*, and to sheep in their first year towards spring, when the loosening and shedding of their teeth render them unable to break the large roots, it is usual to cut or slice the turnips, either by means of a spade, or chopping knife, or by an implement constructed for the purpose, called a turnip-slicer, formerly mentioned (2456.); or they are crushed by means of a heavy wooden mallet.

4899. *During severe frosts*, turnips become so hard that no animal is able to bite them. The best remedy in this case is, to lay them for some time in running water, which effectually thaws them; or, in close feeding houses, the turnips intended for next day's use, may be stored up over night, in one end of the building, and the warmth of the animals will thaw them sufficiently before morning. But in those months when frosts are usually most severe, it is advisable to have always a few days' consumption in the turnip barn. When a severe frost continues long, or if the ground be covered deep with snow, potatoes ought to be employed as a substitute.

4900. *The advantages of eating turnips on the place of their growth by sheep*, both in manuring and consolidating the ground, are sufficiently well known to every farmer. One great defect of the inferior sort of turnip soil is the want of tenacity; and it is found that valuable crops of wheat may be obtained upon very light porous soils, after turnips so consumed. It is not uncommon to let turnips at an agreed price, or board, for each sheep or beast weekly. This varies according to age and size, and the state of the demand, from four-pence or less, to eight-pence or more for each sheep weekly, and from two shillings to five for each beast. An acre of good turnips, say thirty tons, with straw, will fatten an ox of sixty stone, or ten Leicester sheep. Supposing the turnips worth six guineas, this may bring the weekly keep of the ox to six shillings and three-pence halfpenny, and of the sheep to about seven-pence halfpenny a week. In this way of letting, however, disputes may arise, as the taker may not be careful to have them eaten up clean. The person who lets the turnips has to maintain a herd for the taker; and when let for cattle, and consequently to be carried off, the taker finds a man and horse, and the latter maintaining both. The taker has to provide hurdles or nets for fencing the allotments to sheep; but the latter must fence his own hedges if necessary. The period at which the taker is to consume the whole is usually fixed in the agreement, that the seller may be enabled to plough and sow his land in proper season. (*Suppl. to Encyc. Brit. art. Agr.*)

4901. *The Swedish and yellow turnip* are eaten greedily by horses; and afford a very nutritive and salutary food along with hay or straw for working stock. The best mode is to steam them after previously passing them through the slicing machine, as no root requires so much cooking as the Swedish turnip. Horses will also eat the white turnip, but not freely, unless they have been early accustomed to them, as in some parts of Norfolk.

4902. *Near large towns* the most profitable mode of disposing of turnips, is to the cow-keepers and green-grocers.

4903. *The application of turnips in domestic economy* is well known. They may also be used in the distillery, and a wine is said to be made from them by the London manufacturers of imitations of foreign wine.

4904. *The storing of turnips* is attended with too much labor and risk, to be of much advantage in the greater part of the kingdom. Common turnips are never stored in any great quantity, though sometimes a portion is drawn and formed into heaps, like potatoe camps, and lightly covered with straw, or preserved for some time under a shed. On these occasions, the shaws or leaves, and the tap-roots, must be cut off and removed before storing up, to prevent heating and rotting. The heaps must not be covered with earth like potatoes, for in this case their complete destruction is inevitable. This root contains too much water to be preserved for any length of time in a fresh and palatable state, after being removed from the ground; and though the loss in seasons unusually severe, particularly in the *white globe* variety, is commonly very great, it is probable that a regular system of storing the whole, or the greater part of the crop every season, would, upon an average of years, be attended with still greater loss; besides the labor and expense, where turnips are cultivated extensively, would be intolerable. (*Suppl. &c.*)

4905. *Taking up and replacing* is a mode by which turnips have been preserved, by Blaikie, of Holkham, and some others. The mode is to cart the turnips from the field where they grow, to a piece of ground near the farm-offices before the winter rains set in, when the tap-root being cut off, the plants are set on the surface of the ground, in an upright position, as close to each other as they can stand, where they keep much better than in a store, during the whole season. And the advantages of having them quite close to the homestead, in place of bringing them most probably from a distant part of the farm in

wet or stormy weather, are so obvious, as fully to justify a recommendation of the practice.

4906. *Replacing and earthing* have also been tried with success, especially with the Swedish turnip. Being pulled and freed from their roots and leaves, they are carted to a piece of well worked dry soil near the farmery, and there deposited in rows, so close as nearly to touch each other in the bottom of shallow furrows, the plough covering one row as another furrow is opened. In this way many tons are quickly earthed in, and on a very small space, and they can be turned out when wanted with equal facility. (*Farmer's Magazine*, vol. xxiii. p. 282.)

4907. *The produce of turnips* cultivated in the broad-cast manner in England, varies from five to fifteen tons per acre: the latter is reckoned a very heavy crop. In Northumberland and Berwickshire, a good crop of white globe turnips drilled usually weighs from twenty-five to thirty tons per acre, the yellow and Swedish commonly a few tons less. Of late there have been instances of much heavier crops, and in Ayrshire, it would appear, that above sixty tons have been raised on an English acre, the leaves not included. (*Farmer's Magazine*, vol. xv. and xvi.) But such an extraordinary produce must have been obtained by the application of more manure than can be provided, without injustice to other crops, from the home resources of a farm; and where turnips form a regular crop in the rotation, no such produce is to be expected under any mode of culture.

4908. *The produce of the turnip in nutritive matter*, as proved by Sir H. Davy, was forty-two parts in a thousand; of which seven were mucilage, thirty-four sugar, and one gluten. Swedish turnips afforded sixty four-parts in a thousand of nutritive matter, of which nine were starch, fifty-one sugar, two gluten, and two extract. According to Von Thaer, 100 lbs. of turnips are equal to twenty-two of hay; and an ox to get fat on turnips ought to have one-third of its weight daily.

4909. *To raise turnip seed*, the usual mode is to select the most approved specimens of the variety to be raised at the season when they are full grown, and either remove all others from the field and leave them to shoot into flower stems next year, or to transplant them to a place by themselves where they will be secure from the farina of other plants of their genus. In either case they must be protected by earthing up from the winter's frost and rains, and in the ripening season from the birds.

4910. *The Norfolk seed growers* have a sort of theory on the subject of transplanting turnips for seed which it may be worth while to attend to. According to that theory where turnip seed is collected from such turnips as have been sown three or four years in succession, the roots are liable to be numerous and long, and the necks or parts between the bulbs and leaves coarse and thick: and when taken from such as have been transplanted every year, these parts are liable to become too fine, and the tap-roots to be diminished in too great a proportion. Of course the most certain plan is to procure seed from turnips that are transplanted one year and sown the next; or, if they be transplanted once in three years, it is supposed, that the stock may be preserved in a proper state of perfection. It is stated, that the method of performing this business in the best way, is to select such turnips as are of the best kinds and of the most perfect forms, from the field crops, and, after cutting their tops off, to transplant them, about the month of November, or following month, into a piece of ground that has been put into a fine state of tillage by repeated ploughing or digging over, and which should be situated as near the house as it can be, in order that the birds may be better kept from it. The seed will mostly be ready for gathering in the end of July, or in the following month.

4911. *Other cultivators*, however, advise that the seed collected from a few turnips thus transplanted, should be preserved and sown in drills, in order to raise plants for seed for the general crop, drawing out all such as are weak and improper, leaving only those that are strong and which take the lead; and that when these have formed bulbs, to again take out such as do not appear good and perfect, as by this means turnip seed may be procured, not only of a more vigorous nature, but which is capable of vegetating with less moisture, and which produces stronger and more hardy plants. The practice of transplanting the whole of the turnips for seed for the main crops being contended to be not only highly expensive, but injurious, by diminishing the strength of the plants from the destruction of their tap-roots. Very good seed may, however, be raised in either of the methods that have been here described.

4912. *After the seed has become fully ripened*, it is mostly reaped by cutting off part of the stems, and afterwards tying them up into sheaves, which, when sufficiently dry, are put into long stacks, and kept through the winter, in order to be threshed out about the time when it is wanted. But as in this way much seed is liable to be lost, by its readiness to escape from the pods in which it is contained, it is advised as a much better practice to have it immediately threshed out, either upon a cloth in the field where it grew, or in some other convenient place, being then put into bags proper for the purpose and placed in a situation which is perfectly dry. From seed crops of this sort being subject to much injury and loss in different ways, the quantity of produce must be very different under different circumstances; but it may in general be stated at not less than from twenty to twenty-four bushels the acre. And the price of turnip seed being seldom less than seven or eight shillings the bushel, on account of the great demand for it, it may at first appear to be a very advantageous sort of culture; but from the exhausting nature of the crop, the loss sustained in grain, and the quantity of manure afterwards necessary, it is probable that turnip seed can only be grown to advantage in particular circumstances of soil and situation. In most cases it is, however, well for the farmer to raise his own seed, as that of the shops is seldom to be fully depended upon.

4913. *The diseases and injuries to which turnips are liable* are various. At their first appearance their leaves are liable to the attacks of the fly (*Aphis*, and *Crysmela*, L.), of the caterpillar (*Papilio noctua*, &c. L.), of the slug (*Limax*, L.), and of the mildew. Their bulbs and roots are attacked by worms of different kinds; by a singular tendency to monstrosity, known provincially by the name of fingers and toes; by the anbury; by canker, and by wasting or gangrene from water or frost. Of all or most of these injurious diseases, it may be observed, that they neither admit of prevention or cure by art. Under

favorable circumstances of soil, climate, culture, and weather, they seldom occur; and therefore all that the cultivator can do is to prepare and manure his land properly, and in the sowing season supply water when the weather is deficient in showers or the soil in humidity.

4914. *The fly* attacks the turnip when in the seed-leaf, and either totally devours it, or partially eats the leaves and centre-bud, so as to impede the progress of the plants to the second or rough leaves. Whether the eggs of these flies are deposited on the plants or in the soil, does not appear to be ascertained; in all probability they are attached to the former, as in the gooseberry caterpillar, and most cases of flies and insects which feed on plants. Preparations and mixtures of the seed, as already treated of (4890.), is all that has yet been done in the way of preventive to this evil.

4915. *The caterpillar* makes its appearance after the plants have produced three or more rough leaves; these they eat through, and either destroy or greatly impede the progress of the plants. There can be little doubt that the eggs of these caterpillars are deposited on the leaves of the plants by a species of moth, as the caterpillar may be detected when not larger in diameter than a hair. As preventives to the moths from fixing on the turnips for a deposit for their eggs, it has been proposed to place vessels with tar in different parts of the field, the smell of which is known to be very offensive to moths and all insects; by causing a thick offensive smoke to pass over the ground at the time when it is supposed the moths or parent flies were about to commence their operations. To destroy the caterpillar itself, watering with tobacco water, lime water, strong brine, and laying on ashes, barley awns, &c. have been proposed.

4916. *The slug and snail* attack the plants both above and under ground, and eat both the leaves and roots. Rolling, soot, quick-lime, awns, &c. have been proposed to annoy them; but the only effectual mode is, immediately after the turnips are sown, to strew the ground with cabbage leaves, or leaves of any of the Brassica tribe. On these the slugs will pasture, especially if they be beginning to decay (which produces a sweetness), and may be gathered off by women or children every morning. By procuring as many cabbage leaves, or handfuls of decaying pea haulm, or any similar vegetable, as will go over a ridge or two, say at the rate of a leaf to every square yard, a whole field may soon be cleared by picking off the slugs and removing the leaves once in twenty-four hours. This mode we have found most effectual in clearing a whole field of slugs, and it is extensively practised by market and other gardeners. (*Encyc. of Gard.* § 2275.)

4917. *The mildew* and blight attack the turnip in different stages of its progress, and always retard its growth. Its effects may be palliated by watering and strewing the leaves with sulphur; but this will hardly be considered applicable to whole fields.

4918. *The worms which attack the roots*, when they commence their ravages at an early period, impede their growth, and ruin or greatly injure the crop. They admit of no remedy or prevention.

4919. *The forked excrescences*, known as fingers and toes, is considered an alarming disease, and hitherto it can neither be guarded against nor cured. The following account of it is given by William Spence, president of the Holderness Agricultural Society in 1811. "In some plants, the bulb itself is split into several finger diverging lobes. More frequently the bulb is externally tolerably perfect, and the tap-root is the part principally diseased; being either wholly metamorphosed into a sort of misshapen secondary bulb, often larger than the real bulb, and closely attached to it, or having excrescences of various shapes, frequently not unlike human toes, (whence the name of the disease,) either springing immediately from its sides, or from the fibrous roots that issue from it. In this last case, each fibre often swells into several knobs, so as distantly to resemble the runners and accompanying tubers of a potatoe; and not seldom one turnip will exhibit a combination of all these different forms of the disease. These distortions manifest themselves at a very early stage of the turnip's growth; and plants, scarcely in the rough leaf, will exhibit excrescences, which differ in nothing else than size from those of the full-grown root:

4920. *The leaves discover no unusual appearance*, except that in hot weather they become flaccid and droop; from which symptom, the presence of the disease may be surmised without examining the roots. These continue to grow for some months, but without attaining any considerable size, the excrescences enlarging at the same time. If divided at this period with a knife, both the bulb and the excrescences are found to be perfectly solid, and internally to differ little in appearance from a healthy root, except that they are of a more mealy and less compact consistency, and are interspersed with more numerous and larger sap-vessels. The taste, too, is more acrid; and, on this account, sheep neglect the diseased plants. Towards the approach of autumn, the roots, in proportion as they are more or less diseased, become gangrenous and rot, and are either broken (as frequently happens) by high winds, or gradually dissolved by the rain. Some, which have been partially diseased, survive the winter; but of the rest, at this period, no other vestige remains than the vacant patches which they occupied at their first appearance.

4921. *This disease is not owing to the seed, nor to the time of sowing, nor to any quality of the soil*, either original or induced by any particular mode of cropping or of tillage; and Spence adds, that the most attentive and unbiassed consideration of the facts has led him to infer that the disease, though not produced by any insect that has yet been discovered, is yet caused by some unobserved species, which either biting the turnip in the earliest stage of its growth, or insinuating its egg into it, infuses at the same time into the wound a liquid which communicates to the sap-vessels a morbid action, causing them to form the excrescences in question.

4922. *For the prevention of this disease*, marl has been recommended by Sir Joseph Banks and others; and where marl cannot be procured, it has been thought that an addition of mould of any kind, that has not borne turnips, will be advantageous; such as a dressing taken from banks, woodlands, ditches, &c. and mixed up with a good dose of lime. But lime alone has been tried in vain; and no great dependence can be placed upon fresh mould, as this disease has been known to prevail upon lands that had scarcely ever before borne a crop of turnips. (*Farmer's Magazine*, vol. xiii.)

4923. *The anbury* is a disease in the roots of turnips which is thus described by Marshal in his *Rural Economy of Norfolk*:—It is a large excrescence, which forms itself below the apple. It grows to the size of both the hands, and, as soon as the hard weather sets in, or it is, by its own nature, brought to maturity, becomes putrid, and smells very offensively. At present, the state of three specimens which have been taken up and examined attentively, is this:—The apples of the turnips are just forming (about the size of walnuts in the husk), while the anburies are already as big as the egg of a goose. They are irregular and uncouth in their form, with inferior excrescences (resembling the lobes of ginger) hanging to them. On cutting them, their general appearance is that of a hard turnip; but on examining them through a magnifier, there are veins, or string-like vessels, dispersed among the pulp. The smell and taste somewhat resemble those of turnips, but without their mildness, having an austere and somewhat disagreeable flavor, resembling that of an old stringy turnip. The tops of those which are much affected, turn yellow, and flag with the heat of the sun; so that, in the day-time, they are obviously distinguishable from those which are healthy. It seems to be an idea among farmers, that the cause of the anbury is the soil being tired of turnips; owing to their having been too often sown on the same land. This, however, Marshal says, is positively erroneous; for the piece from which these specimens were drawn, was an old orchard, and never before bore turnips in the memory of man. The cause of this disease is probably not yet well ascertained; but if drought does not immediately produce it, the coincidence of a remarkably dry season, and a remarkably anburied turnip crop, justifies a suspicion, that the former does in some measure contribute to promote the latter. Marshal seems, indeed, to conceive that it is caused by some kind of grub or other, that, wounding the vessels of the tap-root, diverts the course of the sap; which, instead of forming the apple, forms this excrescence.

4924. *The canker* attacks the roots and partly the bulbs of turnips, and is known by the ulcerated appearance it produces. Some consider it owing to the presence of too much iron in the soil, and recommend liming as a preventive.

4925. *Wasting and putrefaction*, from excess of water or frost, are to be prevented by earthing up the bulbs, or taking up and storing.

SECT. III. *The Carrot*.—*Daucus carota*, L. *Pentan. Dig. L.* and *Umbelliferae*, J. *Carotte*, Fr; *Gelbe Rübe*, Ger.; and *Carota*, Ital.

4926. *The carrot* is a biennial plant, a native of Britain; but though long known as a garden plant it is comparatively but of recent introduction in agriculture. It appears to have been cultivated from an early period in Germany and Flanders, and introduced from the latter country to Kent and Suffolk early in the 16th century. As the carrot requires a deep soil inclining to sand, it can never enter so generally into cultivation as the potatoe or turnip. But as observed by a judicious writer, it has been too much neglected on lands where it would have yielded a more valuable product, perhaps, than any bulbous or tap-rooted plant whatever. Several contradictory experiments in its culture have been detailed in a number of publications, from which the practical husbandman will be at a loss to draw any definite conclusion. But, in a recent communication to the Board of Agriculture, from Robert Burrows, an intelligent Norfolk farmer, who has cultivated carrots on a large scale, and with great success, for several years, so accurate an account is presented of the culture, application, and extraordinary value of this root, that carrots will probably soon enter more largely into the rotation of crops on suitable soils. (*Supp. &c.*)

4927. *The varieties of carrot* cultivated in gardens are numerous and readily increased by the usual means; but the only sort adapted for the field is the long-red or field carrot. New seed is most essential, as it will not vegetate the second year. Old seed, or a mixture of old and new, and also the mixture of the horn carrot, the seed of which is set over in large quantities from Holland, ought to be carefully avoided.

4928. *The best soil for the carrot* is a deep rich sandy loam; such a soil ought at least to be a foot deep, and all equally good from top to bottom. On any other the field culture of the carrot will not answer.

4929. *In preparing the soil for the carrot*, it is essential to plough it before winter that it may be pulverized by frost; and to work it well by the plough and cultivator in spring, to at least the depth of a foot. This deep tillage may be perfectly accomplished

either by means of the trench-plough following the common one, or by the common one alone, with a good strength of team; but the former method is to be preferred, wherever the lands are inclined to be stiff or heavy. Three ploughings are mostly found sufficient, where the land has been previously in a state of tillage; but more may in other cases be necessary. The first ploughing should be made to the depth of ten, twelve, or fourteen inches, and be performed when the soil is tolerably dry, about the beginning of October. It may remain in this condition till towards the middle of February, when it should be turned over a second time, but in a cross direction, to nearly the same depths. In March, a third ploughing may be given, in order to the putting in of the seed. This may be somewhat lighter than the preceding ones. As soon as the last ploughing has been given in March, the land should be harrowed, and the surface made as fine as possible.

4930. *In Suffolk the farmers sow carrots after turnips*, barley, and pease set upon a rye-grass ley; the crops upon the first have generally been most productive; next to that they prefer the latter. In the first place they feed off the turnips by the beginning of February, and then lay the land up on small balks or furrows, in which state it remains till the second week in March, when it is harrowed down, double-furrowed to the depth of about twelve inches, and the seed sown.

4931. *The climate* most suitable to the carrot is the same as for the turnip; but they will thrive better than the turnip in a dry and warm climate, and are consequently of better growth in the south of England and France, in proportion to their size, in moist climates as Holland and Ireland, than the turnip.

4932. *Manure*, according to some, should not be given to carrots the year they are sown, as it is alleged when the roots meet with it they become forked, scabbed, and wormy. This, however, is chiefly applicable to cases in which recent unfermented manure has been given, or where other manure has not been properly broken in pieces and spread over the soil or in the drills. The Suffolk and Norfolk farmers, who are the best carrot growers, always use dung; a suitable proportion of well-rotted farm-yard dung being constantly turned into the soil at the last ploughing in March, as it has been fully shewn, by various trials detailed in *The Annals of Agriculture*, and other books on husbandry, that, though good crops of carrots may be occasionally grown without the use of manure, it is only by the liberal application of that substance that the greatest produce possible can be obtained, as they are in general found to bear a relative proportion to the quantity that may have been employed.

4933. *Burrows* prepares the land with a good dressing of about sixteen cart loads per acre of rotten farm-yard manure, or cottager's ashes: the load about as much as three able horses can draw, and, if bought, costs about four shillings and sixpence per load, besides the carting on the land. He usually sows wheat stubbles after clover, ploughing the first time in autumn, and once more in the early part of the month of February, if the weather permits; setting on the manure at the time of sowing, which is about the last week in March, or sometimes as late as the second week in April.

4934. *In Suffolk, when carrots are intended to be sown after pease*, they usually plough the stubble as soon as the harvest is over, in order that the land may clear itself of weeds; in December, it is laid up in small balks to receive the benefit of the frosts; in February, it is harrowed down, and manured at the rate of fifteen loads per acre; the manure is ploughed in to the depth of about four inches, and in the month of March the land is double-furrowed, and the seed sown. By pursuing this method, they say, the manure lies in the centre of the soil, and not only affords nourishment and support to the carrot in its perpendicular progress, but renders it easy to be turned up by a single ploughing, and greatly promotes the growth of the succeeding crop of barley. In Norfolk, it is the practice to sow carrots after a crop of turnips. The manure, after being put on the land in the beginning of March, is first ploughed in with a common plough, and afterwards trench-ploughed about fourteen or fifteen inches deep; it is then harrowed very fine, and the seed sown about the middle of March.

4935. *The season for sowing the carrot* preferred by Burrows, is the last week in March or first in April; but he prefers the first period, having generally found early sown crops the most productive.

4936. *The usual preparation of the seed* for sowing is by mixing it with earth or sand, to cause it to separate more freely; but Burrows adds water, turns over the mixture of seeds and moist earth several times, and thus brings it to the point of vegetating before he sows it. "Having weighed the quantity of seed to be sown, and collected sand or fine mould, in the proportion of about two bushels to an acre, I mix the seed with the sand or mould, eight or ten pounds to every two bushels, and this is done about a fortnight or three weeks before the time I intend sowing; taking care to have the heaps turned over every day, sprinkling the outside of them with water each time of turning over, that every part of the sand heaps may be equally moist, and that vegetation may take place alike throughout. I have great advantage in preparing the seed so

long beforehand; it is by this means in a state of forward vegetation, therefore lies but a short time in the ground, and by quickly appearing above ground, is more able to contend with those numerous tribes of weeds in the soil, whose seeds are of quicker vegetation." (*Supp. &c.*)

4937. *Crude*, the French translator of Von Thæer's work, describes in a note (*tom. iv. 237.*) a practice nearly similar to that of Burrows. *Crude* uses *sciure* (night soil) instead of earth, and waters with the drainings of dunghills. He keeps the mixture in a warm, but shady situation for eight days; by that time the seed is nearly ready to vegetate, and he sows it immediately.

4938. *The quantity of seed* when carrots are sown in rows, is two pounds per acre, and for broad-cast sowing five pounds. Burrows sows ten pounds per acre in the broad-cast manner.

4939. *The usual mode of sowing* the carrot is broad-cast; but a much better mode in our opinion would be to sow them in rows at twelve or fourteen inches distance; drawing the drills, and hoeing the intervals by any suitable drill and hoe. The most common practice, however, when carrots are best cultivated, is the hand or broad-cast method, the seed being dispersed as evenly as possible over the land, after the surface has been reduced to a very fine state of pulverisation by harrowing, in order to provide a suitable bed for it to vegetate in; being then covered in by means of a light harrow. As the seed of the carrot is not of a nature to be deposited with much regularity by the drill, and as the young plants can be easily set out to proper distances in the operation of hoeing, this is probably the most appropriate method of putting such sort of seed into the ground. And an additional proof of it is indeed found, in its being that which is almost universally adopted in those districts where carrot-husbandry is practised to the greatest extent. But with the view of having the after-culture of the crops more perfectly performed, and at the same time to save the great expense of hand-labor in hoeing the crop, the drill method has been attempted by some cultivators, but we believe without complete success. The work is finished in equi-distant rows at the distance of from twelve to fifteen or eighteen inches from each other, according to the mode of hoeing that is practised. In this business some cultivators do not make use of drill-machines, but strike the land into small furrows by hoes or other implements contrived for the purpose, and then cast the seed over the ground by the hand, covering it in either by slight harrowing, or hoeing in the tops of the ridgelets. It is added, that "in this method, where a drill-machine is used, it has been advised by an intelligent cultivator to deposit the seed to the depth of one inch in the rows, leaving the spaces of fourteen inches between them as intervals; the seed in these cases being previously steeped in rain-water for twenty-four hours, and left to sprout, after which it is mixed with saw-dust and dry-mould, in the proportion of one peck and a half of each to a pound of the seed. The land is afterwards lightly harrowed over once in a place. Two pounds of seed in this mode is found, as has been observed, sufficient for an acre of land."

4940. *The after-culture* given the carrot consists entirely of hoeing and weeding. In Suffolk they are hoed generally three times in the season. The first time, as soon as the plants can be distinguished from the weeds which surround them, which should be done with three-inch hoes, having handles not above two feet in length. It is an operation that requires to be performed with great attention, as it is extremely difficult to distinguish and separate the young carrots from the weeds. The second hoeing should be given in three or four weeks afterwards, according to the forwardness of the crop; it may be performed with common hoes, care being taken to set out the plants at proper distances. From eight to fifteen or eighteen inches, each way, is the common distance at which they are allowed to stand; and it has been proved, from many years' experience, in districts where they are most cultivated, that carrots which grow at such distances always prove a more abundant crop than when the plants are allowed to stand closer together. The third hoeing is commonly made about the middle or end of June, and in this, besides destroying the weeds, another material circumstance to be attended to, is to set out the carrots at proper distances, and also, wherever any have been left double at the former hoeings, to take the worst of the two plants away.

4941. *Carrots sown according to the plan of Burrows*, are ready to hoe within about five or six weeks. He hoes three and sometimes four times, or until the crop is perfectly clean: the first hoeing is with hoes four inches long, and two and a quarter inches wide. The second hoeing invariably takes place as soon as the first is completed, and is performed with six-inch hoes, by two and a quarter inches wide. By this time the plants are set; the first time of hoeing nothing was cut but the weeds. He leaves the plants nine inches apart from each other; sometimes they will be a foot, or even farther asunder.

4942. *Carrots are taken up* generally in the last week of October. Burrows's practice is to let the work to a man who engages women and children to assist him;

the work is performed with three-pronged forks; the children cut off the tops, laying them and the roots in separate heaps, ready for the teams to take away. "I take up in autumn a sufficient quantity to have a store to last me out any considerable frost or snow that may happen in the winter months; the rest of the crop I leave in the ground, preferring them fresh out of the earth for both horses and bullocks. The carrots keep best in the ground, nor can the severest frosts do them any material injury; the first week in March, it is necessary to have the remaining part of the crop taken up, and the land cleared for barley; the carrots can either be laid in a heap with a small quantity of straw covered over them, or they may be laid into some empty outhouse or barn, in heaps of many hundred bushels, provided they are put together dry. This latter circumstance, it is indispensably necessary to attend to, for if laid together in large heaps when wet, they will certainly sustain much injury. Such as I want to keep for the use of my horses until the months of May and June, in drawing over the heaps, (which is necessary to be done the latter end of April, when the carrots begin to sprout at the crown very fast), I throw aside the healthy and most perfect roots, and have their crowns cut completely off and laid by themselves; by this means, carrots may be kept the month of June out in a high state of perfection." (*Communications to the Board of Agriculture*, vol. vii. p. 72.)

4943. *The storing a whole crop of carrots* may be a desirable practice when winter wheat is to follow them, in which case the same mode may be adopted as for turnips or potatoes, but with fewer precautions against the frost, as the carrot, if perfectly dry, is very little injured by that description of weather.

4944. *The produce of an acre of carrots in Suffolk*, according to Arthur Young, is at an average 350 bushels; but Burrows's crops averaged upwards of 800 bushels per acre, which considerably exceeds the largest crop of potatoes.

4945. *The uses to which the carrot is applied in Suffolk* are various. Large quantities are sent to the London markets, and also given as food to different kinds of live stock. Horses are remarkably fond of carrots, and it is even said, that when oats and carrots are given together, the horses leave the oats and eat the carrots. The ordinary allowance is about forty or fifty pounds a day to each horse. Carrots when mixed with chaff, that is, cut straw, and a little hay, without corn, keep horses in excellent condition for performing all kinds of ordinary labor. The farmers begin to feed their horses with carrots in December, and continue to give them chiefly that kind of provender till the beginning or middle of May; to which period, with proper care, carrots may be preserved. As many of the farmers in that country are of opinion that carrots are not so good for horses in winter as in spring, they give only half the above allowance of carrots at first, and add a little corn for a few weeks after they begin to use carrots.

4946. *The application of the carrot to the feeding of working cattle and hogs* is thus detailed by Burrows. "I begin to take up the carrot crop in the last week of October, as at that time I generally finish soiling my horses with lucern, and now solely depend upon my carrots, with a proper allowance of hay, as winter food for my horses, until about the first week of June following, when the lucern is again ready for soiling. By reducing this practice to a system, I have been enabled to feed ten cart horses throughout the winter months for these last six years, without giving them any corn whatever, and have at the same time effected a considerable saving of hay, from what I found necessary to give to the same number of horses, when according to the usual custom of the country, I fed my horses with corn and hay. I give them to my cart-horses in the proportion of seventy pound weight of carrots a horse per day, upon an average, not allowing them quite so many in the very short days, and sometimes more than that quantity in the spring months, or to the amount of what I withheld in the short winter days. The men who tend the horses, slice some of the carrots in the cut chaff or hay, and barn-door refuse; the rest of the carrots they give whole to the horses at night, with a small quantity of hay in their racks; and with this food my horses generally enjoy uninterrupted health. I mention this, as I believe that some persons think that carrots *only*, given as food to horses, are injurious to their constitutions; but most of the prejudices of mankind have no better foundation, and are taken up at random, or inherited from their grandfathers. So successful have I been with carrots as a winter food for horses, that with the assistance of lucern for soiling in summer, I have been enabled to prove by experiments conducted under my own personal inspection, that an able Norfolk team-horse, fully worked two journeys a day, winter and summer, may be kept the entire year round upon the produce of only one statute acre of land. I have likewise applied carrots with great profit to the feeding of hogs in winter, and by that means have made my straw into a most excellent manure, without the aid of neat cattle; the hogs so fed are sold on Norwich hill to the London dealers as porkers." The profit of carrots so applied, he shews in a subsequent statement, together with an experiment of feeding four Galloway bullocks with carrots, against four others fed in the common way with turnips and hay. (*Communications*, &c.)



4947. *In comparing the carrot with the potatoe*, an additional circumstance greatly in favor of the former is, that it does not require to be steamed or boiled, and it is not more difficult to wash than the potatoe. These and other circumstances considered, it appears to be the most valuable of all roots for working horses.

4948. *The use of the carrot in domestic economy* is well known. Their produce of nutritive matter, as ascertained by Sir H. Davy, is ninety-eight parts in one thousand, of which three are starch, and ninety-five sugar. They are used in the dairy in winter and spring to give color and flavor to butter. In the distillery, owing to the great proportion of sugar in their composition, they yield more spirit than the potatoe; the usual quantity is twelve gallons per ton. They are excellent in soups, stews, and haricots, and boiled whole with salt beef.

4949. *To save carrot seed*, select annually some of the most perfect and best-shaped roots in the taking-up season, and either preserve them in sand in a cellar till spring, or plant them immediately in an open airy part of the garden, protecting them with litter during severe frosts, or earthing them over, and uncovering them in March following. The seed is in no danger of being contaminated by any other plant, as the wild carrot, even should it happen to grow in the neighborhood, flowers later. In August it will be fit to gather, and is best preserved till wanted on the stalks. This is the most certain mode of procuring genuine and new seed, but still it will be found advisable to change it occasionally.

4950. *The diseases of carrots* are only such as are common to most plants, such as mildew, insects, &c. The mildew and worms at the root frequently injure crops, and are to be guarded against as far as practicable by a proper choice of soil, season of sowing, and after culture.

SECT. IV. *The Parsnep.*—*Pastinaca sativa*, L. *Pentan. Dig. L.* and *Umbelliferæ*, J. *Le Panais*, Fr.; *Pastinake*, Ger.; and *Pastinaca*, Ital.

4951. *The parsnep* is a biennial plant with a fusiform root like the carrot, and nearly equal in its products of nutritive and saccharine matter. It is a native of most parts of Europe and generally cultivated in gardens, but is only of late and very partial introduction as a field plant. Its culture has been chiefly confined to the island of Jersey, where it attains a large size, and is much esteemed for fattening cattle and pigs. It is considered rather more hardy than the carrot, and its produce is said to be greater. It may be sown either in autumn or spring, and its seed admits of drilling by machinery. The plants when they come up are more easily recognized than carrots, and therefore their culture is on the whole more simple, less dependant on manual labor, and, therefore, more suited to farming. For the rest, their culture is the same as that of the carrot.

4952. *The variety best suited for the field* is the large Jersey, the seed of which should be procured from the island, as that of the garden parsnep sold by the seedsmen never attains the same size.

4953. *The soil, preparation, and manure* for this plant are the same as for the carrot.

4954. *The quantity of seed* for sowing in drills is from 4 to 5 lbs. per acre, and for broad-cast 6 or 8 lbs. It must always be new, as two years seed does not come up freely. It may or may not be prepared by steeping, but it requires no earth or sand, or rubbing, as it passes freely through the same drill that will sow tares or pease.

4955. *The time of sowing* is generally about the middle of February; but some sow in September, in which case the seed does not vegetate till early in spring. This last method, however, is obviously against the culture of the soil, which must thus remain a year in a consolidated state.

4956. *The manner of sowing* is generally in drills at fifteen or eighteen inches distance: but some sow broad-cast and harrow in the seed; and in Jersey parsneps and beans are generally cultivated together. The beans are first dibbled in, and afterwards the parsnep seed scattered over the surface and harrowed. It is acknowledged that a good crop of both plants is never obtained; and therefore, though this mode may be found to answer in the mild climate of Jersey, it is not to be imitated in other places. Drills or broad-cast without any intermixture of plants are the only advisable modes.

4957. *The after-culture and taking up* is the same as for the carrot, with this difference, that the parsnep when sown broad-cast is generally thinned out to twelve inches at an average plant from plant, and when in rows eighteen inches apart, to nine inches in the row.

4958. *The produce* is said to be greater than that of carrots; and the economical application the same. In the fattening of cattle it is found equal if not superior, performing the business with as much expedition, and affording meat of exquisite flavor and a highly juicy quality. The animals eat it with much greediness. It is reckoned that thirty perches, where the crop is good, will be sufficient to fatten an ox of three or four years old when perfectly lean, in the course of three months. They are given in the proportion of about thirty pound weight morning, noon, and night; the large ones being split in

three or four pieces, and a little hay supplied in the intervals of those periods. And, when given to milch-cows with a little hay in the winter season, the butter is found to be of as fine a color and as excellent a flavor as when feeding in the best pastures. Indeed, the result of experiment has shewn, that not only in neat cattle, but in the fattening of hogs and poultry, the animals become fat much sooner, and are more bulky, than when fed with any other root or vegetable. And that, besides, the meat is more sweet and delicate.

4959. *Parsnep leaves* being more bulky than those of carrots may be mown off before taking up the roots, and given to cows, oxen, or horses, by whom they will be greedily eaten.

4960. *The use of the parsnep in domestic economy* is nearly the same as that of the carrot. They are much esteemed to salt fish, and are sometimes roasted for that purpose. Their produce in nutritive matter is 99 parts in 1000, of which 9 are mucilage, and 90 sugar. Gerarde says, that a very good bread was made from them in his time. They afford as good spirit as the carrot, and make an excellent wine.

4961. *To save parsnep seed*, proceed as with the carrot. The parsnep being more hardy and luxuriant than the carrot, is less liable to the mildew and worms, but equally so to become forked if the soil be not deep and well pulverized, and the manure minutely divided and equally distributed.

SECT. V. *The Field-Beet.* — *Beta*, L. *Pentan. Dig. L.* and *Chenopodeæ*, J. *Betterave*, Fr.; *Mangold-würzel*, Ger.; and *Biettola*, Ital.

4962. *The field-beet*, commonly called the mangold-würzel, and sometimes erroneously the root of scarcity (in German *mangel würzel*), is supposed by Professor Thær to be a mongrel between the red and white beet. It has a much larger bulb than either, and that bulb, in some varieties, grows in great part above ground. It has been a good deal cultivated in Germany and Switzerland, both for its leaves and roots; the leaves are either used as spinach or given to cattle; and the roots are either given to cattle, used in distillation, or for extracting sugar. The culture of the field-beet in Britain is very recent, and it may be questioned whether it has any advantages over the turnip for general agricultural purposes. It admits, however, of being cultivated on ridgelets and with as little manual labor as the turnip, while it will prosper on a stronger soil, and near large towns it is not liable to the depredations usually committed on turnips or carrots, as the root is unpalatable either raw or boiled.

4963. *The variety* preferred in Germany is one slightly tinged with red for cattle, and the pale-yellow variety for the distillery and sugar manufacture. The seed must not exceed a year old, and great care should be taken that the seed of the common red and white beet are not mixed with it. The seed of every variety of beet is very apt to degenerate.

4964. *Any soil* will suit this plant provided it be rich; immense crops have been raised on strong clays; but such soils are not easily prepared for this sort of crop, and are also ill adapted for after-culture. The preparation should be exactly the same as for turnips; and the seed should be sown on the ridgelets in the same manner. Some, however, dibble in the seed in order to save the expense of thinning. The season of sowing is the same as for the parsnep, and should not be deferred later than the middle of April. The after-culture consists in horse-hoeing, hand-hoeing, and weeding, as in the culture of the turnip, and the plants are thinned out to about the same distance in the rows. Blanks may be filled up by transplanting, or, as in the case of the Swedish turnip, whole crops may be reared in this way; but the produce is never so large. As the transplanting, however, takes place in May, more time is afforded, and drier weather obtained for cleaning the soil. The plants are set by the dibbler along the centre of the ridgelets, which are previously consolidated by rolling.

4965. *The produce is, cæteribus paribus*, about the same as that of the Swedish turnip, but the nutritive matter afforded by the beet is 136 parts in 1000, of which 13 are mucilage, 119 sugar, and 4 gluten. According to Von Thær, they afford 10 per cent. of nutritive matter, and are in that respect to hay as 10 to 46, and to potatoes as 20 to 46. An acre would thus appear to afford more nourishment than either turnips, carrots, or parsneps.

4966. *The application of the field-beet* is almost entirely to the fattening of stock, and feeding of milch-cows. Near London they are in repute for the latter purpose; and, according to Von Thær, they cause a great increase of milk, as well as improve its flavor. The tops are first taken off, and given by themselves, and then the roots are taken up, washed, and given raw. The roots are much more easily injured by frost than the turnip, carrot, or parsnep, and are stored with difficulty. The leaves make a very good spinach, but the roots cannot be used in cooking like those of the red beet. In the distillery it is nearly half as productive as the potatoe; but, according to Von Thær, it is not likely to yield much profit in the manufacture of sugar.

4967. *To save seed*, select the finest specimens, preserve them in sand during winter, and plant them in an airy part of the garden in March. The rest is easy.

4968. *To diseases* no plant is less liable than the beet.

SECT. VI. *The Cabbage Tribe.* — *Brassica*, L. *Tetrad. Siliq. L.* and *Cruciferae. J.*  
*Chou*, Fr.; *Kohl*, Ger.; and *Cavolo*, Ital.

4969. *The cabbage tribe* are of the greatest antiquity in gardens, and most of them may be cultivated in the fields with success. For the common purposes of farming, however, there can be little doubt that they will afford less profit than any of the plants hitherto treated of in this chapter; but near large towns or sea-ports, they may answer the purpose of the farm-gardener. Cabbage culture, Brown observes, is much more hazardous, far less profitable, and attended with infinitely more trouble than that of turnips, while the advantages to be derived from them are not, in our opinion, of a description to compensate the extra hazard and trouble thereby incurred.

4970. *The culture of cabbage* has been strongly recommended by several speculative agriculturists, and examples adduced of extraordinary produce and profits; but any plant treated in an extraordinary manner will give extraordinary results; and thus an inferior production may be made to appear more valuable than it really is. One reason why so much has been said in their favor by Arthur Young and other southern farmers, is, that they compare them with the produce of turnips, which, in the south of England, is averaged at only 15 tons per acre.

4971. *The variety of cabbage* cultivated in the fields for cattle, is almost exclusively the large field cabbage, called also the Scotch, Strasburg, drumhead, &c. For the purposes of domestic economy, other varieties of early and late cabbage, as the York, Battersea, sugar-loaf, imperial, &c. are grown, and also German greens, Savoy cabbage, and even Brussels sprouts and brocoli. The Kohl rübe, or turnip-cabbage, has also been tried, but it is not fit to use in British cookery, and in respect to its properties in any other respect, it has not one to recommend it.

4972. *Any soil that is rich* will suit the cabbage, but a strong loam is preferred. The best mode of preparation for field cabbage is that for potatoes or turnips, the plants being dibbled along the centre of each ridgelet. For early cabbage no ridgelets are required, as the plants are inserted in rows, by a line at much narrower distances.

4973. *The season for planting* for a full crop of field cabbages, is usually March; but cabbages may be planted as late as June, and produce a tolerable crop by November; and in this way they may sometimes be made to succeed an unsuccessful sowing of turnips. The plants used in March should be the produce of seed sown in an open loamy part of the garden in the preceding August; but those planted in May or June may be the produce of seed sown in the February or March of the same year.

4974. *The preparation* given to the plants consists in pinching off the extremity of their tap-root, and any tubercles which appear on the root or stem, and in immersing the root and stem in a puddle, or mixture of earth and water, to protect the fibres and pores of the roots and stem from the drought. The plants may then be inserted by the dibber, taking care not to plant them too deep, and to press the earth firmly to the lower extremity of the root. If this last point is not attended to in planting by the dibber, the plants will either die, or, if kept alive by the moisture of the soil or rain, their progress will be very slow. When the distance between the ridgelets is twenty-seven inches, the plants are set about two feet asunder in the rows, and the quantity required for an acre is about 6000 plants. Some recommend sowing as for turnips; but by this mode one of the advantages of a green crop is infringed on: viz. the time given to clean the land. Where cabbages are sown, that operation must be performed at least a month sooner than if they were planted; consequently, the best month of the cleaning season is lost. To plant or sow a green crop on land in good heart, that does not require cleaning, will seldom be found good husbandry. It may succeed near large towns, where roots and other green produce sells high, but it can never enter into any general system of farming.

4975. *The after-culture* consists in horse and hand-hoeing and weeding; and the crop is taken by chopping off the heads with the spade, leaving an inch or two of stalk to each. They may be preserved by housing, but only for a short time. The produce is said to be from 35 to 40 tons per acre. Sir H. Davy found that 1000 parts of cabbage gave 73 of nutritive matter, of which 41 are mucilage, 24 saccharine matter, and 8 gluten.

4976. *The application of the field cabbage* is generally to the feeding of milch-cows, and sometimes to the fattening of oxen and sheep. For the former purpose great care must be taken to remove the outside decaying leaves, otherwise they are apt to give an unpleasant flavor to the milk and butter. Cabbages are also eaten by swine and horses, and are reckoned excellent food for sheep that have newly-dropped their lambs, and for calves. A cow will eat from 100 to 150 lbs. of cabbage per day, and a sheep ten or twelve pounds, besides a moderate allowance of hay. Early or garden cabbages are sold

to green-grocers, or to the consumers, or to ship's victuallers for the purpose of being pickled or made into sour croust.

4977. *To save cabbage seed* select a few fine specimens and plant them by themselves, and where they will be in no danger of being contaminated by others of the Brassica tribe when in flower. The seed will keep many years.

4978. *The diseases of cabbages* are the same as those of the turnip, with the exception of the forked excrescence. On the roots of the plants are frequently found knobs, which, in the preparation for transplanting, should, as we have already observed, be carefully removed.

SECT VII. *Of some other Plants which might be cultivated in the Fields for their Roots or Leaves.*

4979. *Every hardy garden plant* may be cultivated in the fields, and with very little manual labor. Accordingly we find onions, spinach, cress, radishes, and even cucumbers grown by farmers, or farm gardeners in the neighborhood of the metropolis, and also in other places. None of these plants, however, can be considered as belonging to agriculture, nor should we notice those which follow, but because they have been tried and recommended by zealous cultivators, and are treated of in some works on farming. No plant can be considered as belonging to agriculture that is not in sufficient demand, or of sufficient general use in feeding stock, as to admit of its frequent occurrence in rotations, and such certainly cannot be said to be the case with the Jerusalem artichoke and lettuce, now about to be noticed.

4980. *The Jerusalem artichoke* (*Helianthus tuberosus*, L.) is a tuberous-rooted plant with leafy stems from four to six feet high. It thrives well on soft moist soils, and even it is said on moist peat soils, and it is alleged that its tops will afford as much or more fodder per acre than a crop of oats, and its roots half as many tubers as an ordinary crop of potatoes. (*Agricultural Magazine*, 1807-8.) The soil may be cultivated in all respects like the potatoe. The tubers being abundant in the market gardens, are to be had at little more than the price of potatoes.

4981. *The common coss lettuce* (*Lactuca sativa*, L.) has been grown for feeding pigs and other purposes. Arthur Young informs us, in his *Calendar of Husbandry*, that he first observed the sowing of lettuces for hogs practised in a pretty regular system, on the farm of a very intelligent cultivator (not at all a whimsical man) in Sussex. He had every year an acre or two, which afforded a great quantity of very valuable food for his sows and pigs. He adds, that it yields milk amply, and all sorts of swine are very fond of it. And he thinks, that the economical farmer, who keeps many hogs, should take care to have a succession of crops for these animals, that his carts may not be for ever on the road for purchased grains, or his granary opened for corn oftener than is necessary. To raise this sort of crop, the land should have been ploughed before the winter frosts, turning in by that earth twenty loads of rich dung per acre, and making the ridges of the right breadth to suit the drill-machine and horse-hoes, so that in the month of March nothing more may be necessary than to scarify the land, and to drill the seed at one foot equi-distant, at the rate of four pounds of seed per acre. Where the stock of swine is large, it is proper to drill half an acre or an acre of lettuce in April, the land having been well manured and ploughed as directed above, being also scuffled in February and March, and well harrowed, repeating it before drilling. And at this period the crop which was drilled in March (a succession being essentially necessary) should be thinned in the rows by hand, to about nine or ten inches asunder. If this necessary attention be neglected, the plants, he says, draw themselves up weak and poor, and will not recover it. Women do this business as well as men. When about six inches high, they should be horse-hoed with a scarifier or scuffler, having the hoe about four inches, or at most five inches in width. With this sort of green food some kind of meal, or other dry meat, should be combined, as without it, it is apt to prove very laxative, &c. — This Sussex cultivator is not likely to be followed by any rent-paying farmer, who can grow any of the clovers, turnips, or potatoes. The quotation affords a good specimen of Arthur Young's mode of writing on agricultural subjects,

---

CHAP. V.

*Of the Culture of Herbage Plants.*

4982. *The cultivation of clovers and other herbage plants* used exclusively as food for live stock, is comparatively a modern improvement. They were known, as we have seen, to the Greeks and Romans, and cultivated from a very early period in the Low Countries; but do not appear to have attracted much notice in Britain till the sixteenth century, when our frequent intercourse with Holland led to the introduction of some of our best field plants and agricultural practices. At present clovers enter largely into the succession of crops, on all soils, and in every productive course of management. Before they were introduced into cultivation, when land was exhausted by grain crops, it was necessary to leave it in a state of comparative sterility for several years, before it was either valuable as pasture, or again fit for carrying corn. But at present, clovers are not only indispensable in the cultivation of white and green crops alternately, upon very rich soils, but are the foundation of convertible husbandry on land that is not so rich as to permit of a constant aration, and which therefore requires two or more years' pasturage at certain intervals. Lucern and saintfoin, though of much less value as general crops, are valuable plants

in particular situations; more especially the latter, which will produce good crops on dry chalky and limestone soils, when most other agricultural plants and even grasses would barely maintain their existence.

4983. *The characteristic points of culture of this class of plants are broad-cast sowing, mowing, soiling, and hay-making, and that when cut for the two last purposes, two or more crops may be had in a season from the same roots.*

4984. *The nutritive products of the principal herbage plants are thus given by Sir H. Davy :*

Systematic name.	The quantity analysed, of each sort 1000 parts.	Whole quantity of soluble or nutritive matter.	Mucilage or starch.	Saccharine matter or sugar.	Gluten or albumen.	Extract, or matter rendered insoluble during evaporation.
Trifolium pratense - -	Red clover - -	89	31	3	2	3
medium - -	Cow grass - -	39	30	4	3	2
repens - -	White clover - -	32	29	1	3	5
Hedysarum onobrychis - -	Saintfoin - -	39	28	2	3	6
Medicago medic - -	Lucern - -	23	18	1	—	4

SECT. I. *The Clover Family.*—*Trifolium*, L. *Diadel. Decan. L.* and *Leguminosæ*, 'J. *Tréfle, Fr. ; Klee, Ger. ; and Trifoglio, Ital.*

4985. *The clovers (fig. 568.) are a numerous family, chiefly natives of Europe: those selected by the agriculturist are natives of Britain; and one species, the white or*



creeping clover, is often found in great luxuriance in native pastures. As rye-grass is very generally sown with clovers, it will be necessary to treat of its culture in connection with these plants, reserving, however, the more particular consideration of rye-grass till we treat of the hay grasses. (Chap. VI.) Many intelligent cultivators consider rye-grass as a very severe crop for the soil; and it is alleged that wheat does not succeed well after the herbage with which rye-grass is intermixed in any considerable quantity. Other plants have accordingly been recommended as a substitute for rye-grass, and cock's-foot (*Dactylis glomerata*) has been tried, apparently with great success, by Coke, of Holkham in Norfolk, and others. But this is a very coarse grass when allowed to rise to any height, and the use of it for hay has not yet been ascertained. Donaldson considers the general introduction of clovers, and the cultivated grasses, as one of the greatest improvements in modern husbandry. The commencement of improvements in the different species of live-stock, in the modes of cultivation, and in the superior quality, as well as quantity, of the crops of grain, may all, he thinks, be dated from the period when the sowing of clovers and grass-seeds was first introduced into the different districts of the kingdom.

4986. *The species of clover in cultivation are the red clover, (Trifolium pratense, a), a biennial, and sometimes, especially on chalky soils, a triennial plant, known from the other species by its broad leaves, luxuriant growth, and reddish purple flowers.*

4987. *The white, or creeping, or Dutch clover, (T. repens, b), a perennial plant, known by its creeping stems and white flowers.*

4988. *The yellow clover, hop-trefoil, or shamrock clover, (T. procumbens, c), a biennial, known by its procumbent shoots, yellow flowers, and black seeds.*

4989. *The cow-grass, meadow clover, or marl-grass, (T. medium, d) a perennial, resembling the red clover, but of a paler hue, dwarfer habit, with pale red or whitish flowers, and long roots very sweet to the taste.*

4990. *Trifolium incarnatum*, an annual and native of Italy, has been recommended by an Italian professor to Sir John Sinclair (*Farm. Jour. Aug. 1821*); but it is not likely that such a plant, which even as an annual in our garden borders has not a fourth of the vigor of the common clover, should ever be worth culture in this country.

4991. *In the choice of sorts* the red or broad clover is the kind most generally cultivated on land that carries white and green crops alternately, as it yields the largest produce for one crop of all the other sorts. White and yellow clover are seldom sown with it, unless when several years pasturage is intended.

4992. *The soil best adapted for clover* is a deep sandy loam, which is favorable to its long tap-roots: but it will grow in any soil, provided it be dry. So congenial is calcareous matter to clovers, that the mere strewing of lime on some soils will call into action clover-seeds, which it would appear have lain dormant for ages. At least this appears the most obvious way of accounting for the well-known appearance of white clover in such cases.

4993. *The climate most suitable for the clovers*, as of most plants, natives of Europe, is one neither very hot nor very dry and cold. Most leguminous plants delight both in a dry soil and climate, and warm temperature, and the clover will be found to produce most seed under such circumstances; but as the production of seed is only in some situations an object of the farmer's attention, a season rather moist, provided it be warm, is always attended by the most bulky crops of clover herbage.

4994. *The preparation of the soil and manures*, which clover receives in ordinary farm culture, are those destined also for another crop; clover mixed with a certain proportion of rye-grass being generally sown along with or among corn crops, and especially with spring sown wheat, barley, and the early varieties of oats. Unless, however, the soil on which these crops are sown are well pulverized, and have been some years under tillage, clovers will not succeed in them, it being ascertained that newly-broken-up leys or pasture grounds cannot be sown down or restored to clover and grasses, till the soil is thoroughly comminuted, and the roots of the former grasses and herbage plants completely destroyed.

4995. *The time of sowing clover-seeds* is generally the spring, during the corn-seed time, or from February to May; but they may also be sown from August to October, and when they are sown by themselves, that is, unaccompanied by any corn crop, this will be found the best season, as the young plants are less liable to be dried up and impeded in their progress by the sun, than when sown alone in spring, and remaining tender and unshaded during the hot and dry weather of July.

4996. *Some prepare the seed for sowing* by steeping in water or in oil, as in Switzerland, and then mixing it with powdered gypsum, as a preventive to the attacks of insects.

4997. *The manner of sowing* is almost always broad-cast. When sown with spring corn, clover and grass-seeds are usually put in immediately after the land has been pulverized by harrowing in the corn-seed, and are themselves covered by one course more of the harrows; or, if the corn is drilled, the small seeds are sown immediately before or after hand-hoeing; and the land is then finished by a course of the harrows. A lighter harrow is generally employed in covering such seeds, than that used for corn. When the land is under an autumn sown crop of wheat or other grain, though the clovers and rye-grass are still sown in spring, the proper period must depend both upon the state of the land, and the progress of the crops; and it may be often advisable to break the crust formed on the surface of tenacious soils, by using the harrow before the clovers are sown, as well as afterwards to cover them. Sometimes the roller only is employed at this time, and there are instances of clover and rye-grass succeeding when sown, without either harrowing or rolling. But it is commonly of advantage to the wheat crop itself, to use the harrows in spring, and the roller alone cannot be depended on, unless the season be very favorable. In some cases grass-seeds are sown by themselves, either in autumn or spring, but rarely on tillage land. Nature has not determined any precise depth for the seed of red clover more than of other seed. It will grow vigorously from two inches deep, and it will grow when barely covered. Half an inch may be reckoned the most advantageous position in clay soil; a whole inch in what is light or loose. It is a vulgar error, that small seed ought to be sparingly covered. Misled by that error, farmers commonly cover their clover seed with a bushy branch of thorn; which not only covers it unequally, but leaves part on the surface to wither in the air.

4998. *In the operation of sowing* some consider it best to sow the clover and rye-grass separately, alleging that the weight of the one seed and lightness of the other, are unfavorable to an equal distribution of both.

4999. *The quantity of seed sown on an acre* is exceedingly various; not only according as more or less white or yellow clover is sown along with grass-seeds and red clover, or when pasturage is intended, but, even when they are the only kinds sown, the quantity is varied

by the quality of the soils, and the different purposes of hay, soiling, or one year's pasture, to which the crop is to be applied. When pasture is the object, more seed ought to be allowed than is necessary when the crop is to be cut green for soiling; and for hay, less may suffice than for either of the former. Finely pulverized soils do not require so much seed as clays, on which clover and rye-grass are very frequently sown among autumn or winter-sown wheat, when there is more danger of a part of it perishing from being imperfectly covered. In general, eight or ten pounds may be taken as the *minimum* quantity, though there have been instances of good crops from less; and from that to fourteen pounds or more per English statute acre. Rye-grass, commonly at the rate of a bushel per acre, but in many cases only half, or two-thirds of a bushel, is mixed with this weight of clover, and both are sown at the same time. The rye-grass may be either of the perennial or annual variety, as it is understood that the herbage is to be continued for only one year; and the annual is sometimes sown in preference, as producing a bulkier crop than the perennial.

5000. *When it is intended to retain the land in pasture for several years*, the quantity of red clover is diminished, and several kinds of more permanent herbage are added, the most common of which are white and yellow clover, and ribwort. No general rule can be laid down as to the proper quantity of each of these kinds; in some cases red and white clover are sown in equal proportions, and in others the latter is made greatly to predominate. The yellow clover and ribwort are not often sown at the rate of more than two or three pounds per acre. It is scarcely necessary to add, that, in this case, the rye-grass should always be of the perennial sort.

5001. *In the selection of clover and rye-grass seeds* particular attention should be paid to their quality and cleanness; the purple color of the clover seed denotes that it has been ripe and well saved; and the seeds of weeds may be detected in it by narrow inspection, if there be any; but various noxious weeds are frequently mixed up with the seeds of the rye-grass, which it is difficult either to discover or to separate from them. Between the seeds of the annual and perennial rye grass, the difference is hardly discernible; and therefore, unless it is of his own growth, the cultivator must depend in a great measure on the character of the person from whom he purchases it. Red clover from Holland or France, has been found to die out in the season immediately after it has been cut or pastured; while the English seed produces plants, which stand over the second, many of them the third year (*General Report of Scotland*, vol. i. p. 537.); thus remaining in the latter case four summers in the ground from the time of sowing.

5002. *The after-culture of clover and rye-grass* consists chiefly of picking off any stones or other hard bodies which may appear on the surface in the spring succeeding that in which it was sown, and cutting out by the roots any thistles, docks, or other large grown weeds. After this the surface should be rolled once to smooth it for the scythe. This operation is best performed in the first dry weather of March. Some give a top-dressing of soot, gypsum, common lime, peat, or wood-ashes at this time or earlier; Gypsum has been particularly recommended as a top dressing for clovers, and the other herbage legumes, because as their ashes afford that substance in considerable quantities, it appears to be a necessary ingredient of their food. Dutch ashes (420.) have been strongly recommended as a top-dressing for red clover, and they also contain gypsum; but where the soil is in good heart, and contains calcareous matter, any description of top-dressing, though it may be of advantage when it does not interfere with the general economy of the farm, cannot be considered as necessary. (*Sup. E. Brit. art. Agr.*)

5003. *The taking of the clover, or clover and rye-grass crop*, is either by cutting green for soiling, by making into hay, or by pasturing. It is observed in *The Code of Agriculture*, that it is a most important point to ascertain, in what cases cutting, or feeding, is most beneficial. If fed, the land has the advantage of the dung and urine of the pasturing stock; but the dung being dropt in irregular quantities, and in the heat of summer, when it is devoured by insects, loses much of its utility. If the dung arising from the herbage, whether consumed in soiling, or as hay, were applied to the land, in one body, and at the proper season, the operation would be more effectual. The smother of a thick crop, continued for any time upon the ground, greatly tends to promote its fertility; and it has been pretty uniformly found, after repeated trials, upon soils of almost every description, that oats taken after clover that has been cut, either for soiling or hay, is superior to the crop taken after clover pastured by sheep.

5004. *Soiling* is a term applied to the practice of cutting herbage crops green for feeding or fattening live stock. On all farms, under correct management, a part of this crop is cut green, for the working horses, often for milk cows, and, in some instances, both for growing and fattening cattle. There can be no doubt of the advantages of this practice, in regard to horses and cows; but for young, and for fattening beasts, a sufficient number of experiments are not known to have been yet made with any great degree of accuracy. Young animals require exercise in the open air, and, probably, will not be found to thrive so well in houses or fold-yards, during summer, as on pastures; and though in every

case there is a great saving of food, the long, woody, and comparatively naked stems of the plants, with leaves always more or less withered, are perhaps not so valuable in the production of beef on fattening stock, as a much smaller weight of herbage taken in by pasturage. Milk-cows, however, are so impatient of heat and insects, that this way of feeding them, and at least for a part of the day, in warm weather, ought to be more generally adopted; and the convenience of having working horses always at hand, besides that they fill their stomachs speedily, is of not less importance than economy. (See *Communications to the Board of Agriculture*, vol. vii. *Brown's Treatise on Rural Affairs*, vol. ii. *General Report of Scotland*, vol. ii. and iii.)

5005. *In feeding cattle with green clover*, attention must be paid to prevent swelling, or hoving, which is very apt to take place when they are first put on this food, especially if it be wet with rain or dew; and cattle are exposed to this danger, whether they are sent to depasture the clover, or have it cut and brought home to them; though, if the plants be somewhat luxuriant, the danger is greater in the former case. After being accustomed to this rich food for a few days, during which it should be given rather sparingly, the danger is much diminished; but it is never safe to allow milch cows, in particular, to eat large quantities of wet clover.

5006. *The making herbage plants into hay* is a process somewhat different from that of making hay from natural grasses. All the herbage tribe ought to be mown before the seed is formed, and indeed before the plants have fully blossomed, that the full juice and nourishment of the herb may be retained in the hay. By the adoption of this system, the hay is cut in a better season, it can be more easily secured, and it is much more valuable. Nor is the strength of the plant lodged in the seed, which is often lost. The great advantage of converting under-ripe herbage and grass into hay is now beginning to be known. There is much more saccharine matter in it, and it is consequently greatly more nutritious. A crop of clover or saintfoin, when cut in the early part of the season, may be ten per cent. lighter than when it is fully ripe; but the loss is amply counterbalanced, by obtaining an earlier, a more valuable, and more nutritious article; while the next crop will proportionably be more heavy. The hay from old herbage will carry on stock, but it is only hay from young herbage that will fatten them. When the stems of clover become hard and sapless, by being allowed to bring their seeds towards maturity, they are of little more value as provender, than an equal quantity of the finer sort of straw of corn.

5007. *The mode of making clover-hay*, and that of all herbage plants, as practised by the best farmers, is as follows. The herbage is cut as close to the ground and in as uniform and perfect a manner as it is possible to accomplish, by the scythe kept constantly sharp. The surface having been in the preceding spring freed from stones and well rolled, the stubble after the mower ought to be as short and smooth as a well shaven grass lawn. What part of the stems is left by the scythe, is not only lost, but the after-growth is neither so vigorous nor so weighty, as when the first cutting is taken as low as possible.

5008. *As soon as the swath or row of cut herbage is thoroughly dry above*, it is gently turned over (not tedded or scattered), without breaking it. Sometimes this is done by the hand, or by a small fork; and some farmers are so anxious to prevent the swath from being broken, that they will not permit the use of the rake shaft. The grass, when turned over, in the morning of a dry day, is put into cocks in the afternoon. The mode of performing this is very simple and expeditious; and none but women, boys, and girls, under the eye of a confidential servant, are usually employed. If the crop is heavy, a row of cocks is placed in the middle ridge of three, and if light of five ridges. A distinct company of carriers and rakers is allotted to every such number of ridges; and the separate companies proceed each on its own ground, and in the same manner as in reaping grain, which occasions a degree of competition among them for despatch, clean raking, and neat well-built cocks. The carriers gather the hay, and carry it to the ridge where the cock is to be built, by one of the most experienced hands. A raker follows the carrier, taking up and bringing to the cocks the remains of the swath. There may be, in general, about five people employed about each row of cocks; a carrier and raker on each side of the ridge on which the cocks are placed, and a person on the ridge, who builds them. But when the crop is not weighty, more rakers are required, as a greater space must be gone over.

5009. *As the cocks are thus placed in a line*, it is easy to put two or more into one afterwards; and the larger cocks may be speedily drawn together, to be put into tramp-ricks, by means of ropes thrown round their bottoms, and dragged along by a horse. It is impossible to lay down any rules for the management of hay, after it is put into cocks; one thing is, however, always attended to, not to shake out, scatter, or expose the hay oftener than is necessary for its preservation. Sometimes the cocks have been put up so large, that they never require to go to a tramp-rick, but were carted to the stack-yard, without ever being broken, and put up in alternate layers with old hay. But where this is attempted, there must not be much clover. The practice of mixing the new with the old hay is, however, a good one, and saves a great deal of time and labor, at the same time that the old hay is much improved by the mixture.

5010. The best managers disapprove of *spreading out the swaths of clover and rye-grass*, though this is often necessary with natural grasses, which are cut and harvested later in the season. The more the swath is kept unbroken, the hay is greener, and the more fragrant.

5011. *Another mode of hay-making*, said to have been originally practised in Lancashire, has been found to answer well in the moist atmosphere of the west of Scotland. This is called tipping or rippling; and if the grass be dry, the operation begins as soon as it is mown. "In making a tittle, a person with his right-hand, rolls the swath inwards, until he has a little bundle; then the same is done by the left, until both meet, and form eight to twelve pounds, or nearly so. This bundle is then set up against the legs, or between the feet; a rope is twisted of the grass, while the bundle is supported in this manner, and tied round it near its top; and from the top are drawn up a few straggling stems, which are twisted to make the tittle taper to a point, and give it as much a conical shape as possible. If the crop is strong, there is a row of tipples placed on each swath; if light, two of these are put into one row. After standing a few hours, they become so smooth on the outside, that the heaviest rains seldom wet them through; and when



wet, they are soon dried again in good weather. As soon as ready, they are put into the summer-rick, or, if very dry, even the winter-stack, but are never opened out or tedded, to make them dry, as they never require it. By this method, not a blade is lost, and the hay is nearly as green as a leaf dried in a book. In a moderate crop, one woman will tipple to one mower, and a woman will rake to two tippers, or two swathers. But where the crop is strong, it may require three women to keep pace with two mowers. After the hay is put up in this manner, the crop may be considered as secure, though it may continue wet weather for a considerable length of time." (*General Report of Scotland*, vol. ii. p. 11.)

5012. Hay is *stacked* in circular or oblong stacks, the latter form being most generally approved of, and carefully thatched, as has been already observed in regard to corn. It is never advisable to allow this kind of hay to become heated in any considerable degree, in the stack, though a slight exudation, with a very gentle warmth, is usually perceptible, both in the field-ricks and in the stacks, for a few days after they are built. But this is a quite different thing from that intentional heating, carried so far, in many instances, as to terminate in conflagration.

5013. *The after-growth or second crop of clover* is vigorous or weak, according to the proportion of clover plants to rye-grass, to the time when the first crop was cut, and to the moisture and warmth of the season. When the first cutting has been made early for soiling, there will sometimes be three cuttings in one season. The first of these after-cuttings may be made into hay, and sometimes the second; but in general, both are consumed by soiling or pasturing, unless in some dry warm districts, as Norfolk, and parts of Suffolk, Kent, &c., when the second growth is left to ripen its seed. In the northern counties the second crop is seldom made into hay, owing to the difficulty of getting it thoroughly dried at a late period of summer, when other more urgent operations usually employ all the laborers of a farm. If it be cut for this purpose, the best method of saving it, is to mix it up with straw, which will absorb a part of its juices. It is often cut green, as a part of the soiling system; or, where a sheep stock is kept, pastured by the old ewes, or other sorts, that are to be fattened the ensuing winter on turnips.

5014. *In consuming clover and other herbage plants by pasturing or eating down on the spot*, three methods have been adopted, tethering, hurdling, and free pasturage.

5015. *Tethering* may be considered a rude practice, and is chiefly confined to the north of Scotland and Ireland. In *The Agricultural Report of Aberdeenshire*, it is stated, that there are some cases, where the plan of tethering can be practised with more profit than even soiling. In the neighborhood of Peterhead, for instance, they tether milch-cows on their grass fields, in a regular and systematic method; moving each tether forward in a straight line, not above one foot at a time, so as to prevent the cows from treading on the grass that is to be eaten; care being always taken, to move the tether forward, like a person cutting clover with a scythe, from one end of the field to the other. In this way, a greater number of cows can be kept, on the same quantity of grass, than by any other plan; except where it grows high enough to be cut, and given them green in houses. In one instance, the system was carried to great perfection, by a gentleman who kept a few sheep upon longer tethers, following the cows. Sometimes also, he tethered horses afterwards upon the same field, which prevented any possible waste, for the tufts of grass produced by the dung of one species of animal, will be eaten by those of another kind, without reluctance. This system was peculiarly calculated for the cow-feeders in Peterhead; as, from the smallness of their holdings, they could not afford to keep servants to cut, or horses to carry home the grass to their houses, to be consumed in a green state. (*Code.*)

5016. *In hurdling off clovers or herbage crops*, a portion of the field is enclosed by hurdles, in which sheep are confined; and as the crop is consumed, the pen is changed to a fresh place, until the whole is fed off. This practice is very extensively adopted at Holkham, and is peculiarly calculated for light and dry soils. Its advantages are, that the grass is more economically consumed; that the stock thrive better, having daily a fresh bite; and that the dung that falls, being more concentrated, is more likely to be of use.

5017. *In the common pasturing of clover*, the stock are introduced into the field earlier than in tethering or hurdling, in order to avoid the loss that would be sustained by cattle or sheep treading *ad libitum* on tall herbage. Indeed, the principal advantage of pasturing clovers is, that sheep and lambs may be turned on them more early than on common grass-lands. Sometimes this advantage is taken for a month or six weeks, in the beginning of summer, and the field afterwards shut up for a crop of hay; but more frequently the red clovers are only pastured the second year. When white and yellow clovers are sown, the herbage is sometimes not mown at all, but pastured for three or more years, and sometimes a little red clover being sown along with these, a crop of hay is taken the first year.

5018. *The produce of clover-hay*, without any mixture of rye-grass, on the best soils is from two to three tons per acre, and in this state in the London market it generally sells 20 per cent. higher than meadow-hay, or clover and rye-grass mixed. The weight of hay from clover and rye-grass varies, according to the soil and the season, from one to three tons per English acre, as it is taken from the tramp-ricks; but after being stacked, and kept till spring, the weight is found to be diminished 25 or 30 per cent.

5019. *The value of clover and rye-grass hay*, in comparison with the straw of beans or pease, may be in the proportion of three to two; and with the finest straw of corn crops, in the proportion of two to one. One acre of red or broad clover will go as far in feeding horses or black cattle, as three or four of natural grass. And when it is cut

occasionally, and given to them fresh, it will, probably, go still much farther, as no part of it is lost by being trodden down. With the exception of lucern, and the herbage of rich marshes, there is no crop, by which so much stock can be supported, as by clover. It may be profitably employed in fattening sheep in spring, and with this food, they will soon be ready for the butcher. Afterwards, a crop of hay may be got, and two or three weeks after the hay has been taken off, sheep intended to be fattened on turnips, may be turned in, and kept there, until the turnips are ready for them.

5020. *The nutritive products of clovers* will be found in the table. (4984.)

5021. *The saving of clover seed* is attended by considerable labor and difficulty. Clover will not perfect its seeds, if saved for that purpose early in the year; therefore it is necessary to take off the first growth either by feeding or with the scythe, and to depend for the seed on those heads that are produced in the autumn. Seed-clover turns out to good account in those years when the crops are not injured by the blight, which is often fatal to them, or by the rains in the autumn, which sometimes prove their destruction; for the time of harvesting this seed falling out late when rainy weather may be expected, renders it, on that account, very tedious.

5022. *When the first crop is fed off*, it is eaten till about the end of May, frequently by ewes and lambs; and this is understood to be an advantageous practice, because the land is less exhausted, and the green food is of great value for stock in the spring months. It is not uncommon, however, to cut the first growth for a hay crop, and this should be done earlier than usual. The growth thus reserved for seed must be suffered to remain till the husks become perfectly brown, when it is cut and harvested in the usual manner, leaving it on the field till it is very dry and crisp, that the seeds may become more fully hardened; it may then be laid up dry, to be threshed out at the farmer's convenience. Much labor and expense are necessary in separating the seed from the capsule, or seed-coat, especially when it is effected by threshing, which seldom costs less than from five to six or seven shillings per bushel. By the use of mills the work may be done much cheaper.

5023. *The produce in seed* may generally be from three to four or five bushels per acre, when perfectly clean, weighing from two to three hundred weight. But there is great uncertainty in the produce of clover seed, from the lateness of the season at which it becomes ripe; and the fertility of the soil is considerably impaired by such a crop. Yet the high value of the seed is a great inducement to the saving of it, in favorable situations. (*Dickson's Practical Agriculture*, vol. ii. p. 863.)

5024. *The diseases of clover* are the blight or mildew, and suffocation or consumption, from insects, slugs, and worms. It often happens that clover after being repeated at short intervals on the same soil, either fails or does no good; whether that is owing to a disease or to a defect in some peculiar substance, which enters into the food of the plant, does not appear to be clearly ascertained. A top dressing with ashes or lime, is said to be unfavorable to the slug; but where vermin of this sort are very numerous, the most certain remedy is a naked fallow well worked in the hottest months.

SEED. II. *Lucern*. — *Medicago sativa*, L. *Diadel. Decan.* L. and *Leguminosæ*, J. *La Lucerne*, Fr.; *Futterklee*, Ger.; and *Medica*, Ital. (fig. 569.)

5025. *Lucern* is a deep rooting perennial plant, sending up numerous small and tall clover-like shoots, with blue or violet spikes of flowers. It is a native of the south of Europe, and appears to be acclimated in the warmer parts of England. Lucern or medic is highly extolled by the Roman writers, and also the cytissus, the latter a low evergreen shrub. Lucern is much grown in Persia and Lima, and mown in both countries all the year round; it is also of unknown antiquity in old Spain, Italy, and the south of France. It was introduced to England from the latter country, according to Miller, in 1657. It is mentioned by Hartlib, Blythe, and other early writers, and was tried by Lisle; but it excited little attention till after the publication of Harte's *Essays*, in 1757. It is now only cultivated in a few places, and chiefly in Kent. Columella estimated lucern as the choicest of all fodder, because it lasted many years, and bore being cut down four, five, or six times a year. It enriches, he says, the land on which it grows, fattens the cattle fed with it, and is often a remedy for sick cattle. About three quarters of an acre of it is, he thinks, abundantly sufficient to feed three horses during the whole year. But though it was so much esteemed by the ancients, and has been long cultivated to advantage in France and Switzerland, it has yet found no great reception in this country. If any good reason can be given for this, it is, that lucern is a less hardy plant than red clover, requires three or four years before it comes to its full growth, and is for these and other reasons, ill adapted to enter into general rotations. Where the climate and soil suit, perhaps, a field of it may be advantageously sown, adjoining the homestall, to afford early cutting or food for young or sick animals, for which it is said to be well adapted; but though it will produce good crops for eight or ten years, yet from the time the



farmer must wait till this crop attains its perfection, and from the care requisite to keep it from grass and weeds, we do not think it is ever likely to come into general culture.

5026. There are no varieties of the lucern deserving the notice of a cultivator. What is called the yellow lucern, or Swiss lucern, is the *Medicago falcata* (fig. 570.), a much more hardy and coarser plant, common in several parts of England, but not cultivated any where excepting in some poor soils in Switzerland.

5027. *The soil* for lucern must be dry, friable, inclining to sand, and with a subsoil not inferior to the surface. Unless the subsoil be good and deep, it is in vain to attempt to cultivate lucern. According to Young, the soils that suit lucern, are all those that are at once dry and rich. If, says he, they possess these two criteria, there is no fear but they will produce large crops of lucern. A friable deep sandy loam on a chalk or white dry marly bottom, is excellent for it. Deep putrid sand warp on a dry basis, good sandy loam on chalk, dry marl or gravel, all do well; and in a word, all soils that are good enough for wheat, and dry enough for turnips to be fed on the land, do well for lucern. If deficient in fertility, they may be made up by manuring, but he never yet met with any land too rich for it.

5028. *The preparation of the soil* consists in deep ploughing and minute pulverisation; and in our opinion, the shortest way to effect this, is to trench it over by the spade to two or three feet in depth, burying a good coat of manure in the middle or at least one foot from the surface. This is the practice in Guernsey, where lucern is highly prized.

5029. *The climate* for lucern, as we have already hinted, must be warm and dry; it has been grown in Scotland and Ireland, and might probably do well in the southern counties of the latter country, but in the former it has not been found to answer the commendations of its admirers.

5030. *The season* most proper for sowing lucern, is as early as can be done in the spring months, as in this way the plants may be fully established before the season becomes too hot. The latter end of March, for the more southern districts, may be the most proper period; and the beginning of the following month for those of the north. When sown late, there is more danger of the plants being destroyed by the fly, as has been observed by Tull. If the plants be intended to be transplanted out in the garden method, it will also be the best practice to sow the seed-bed as early in the spring as the frosts will admit, in order that they may be strong, and fit to set out about the beginning of August.

5031. *The manner of sowing* lucern is either broad-cast or in drills, and either with or without an accompanying crop of corn for the first year. Broad-cast, and a very thin crop of barley or other spring corn, is generally, and in our opinion, very properly preferred. Arthur Young, who has treated largely on this plant, observes, that "the greatest success by far that has been known, is by the broad-cast method, which is nearly universal among the best lucern farmers, even among men who practise and admire the drill husbandry in many other articles. But as they mostly (not all) depend on severe harrowing for keeping their crops clean, which is a troublesome and expensive operation, he still ventures to recommend drilling, but very different drilling from that which has been almost universally practised, viz. at distances of eighteen inches or two feet. Objections to these wide intervals are numerous. If kept clean hoed, the lucern licks up so much dirt, being beaten to the earth by rain, &c. that it is unwholesome, and the plants spread so into these spaces, that it must be reaped with a hook, which is a great and useless expense. For these reasons, as well as for superiority of crop, he recommends drilling at nine inches, which in point of produce, mowing, and freedom from dirt, is the same as broad-cast; and another advantage is, that it admits scarifying once a year, which is much more powerful and effective than any harrowing. These facts are sufficient to weigh so much with any reasonable man, as to induce him to adopt this mode of drilling, as nearer to broad-cast by far than it is to drills at eighteen to twenty-four inches, which open to a quite different system, and a set of very different evils. Nine inch rows might practically, but not literally, be considered as broad-cast, but with the power of scarifying. And in regard to the material point, of with or without corn, two considerations, he says, present themselves. One is the extreme liability of lucern to be eaten by the fly, which does great mischief to many crops when very young, and against which the growing of corn is some protection. The value of the barley or oats is another object not to be forgotten. It is also gained in the first year's growth of the lucern, which is very poorly productive even if no corn be sown, so that he must own himself clearly an advocate for drilling in among corn, either between the rows of nine inch barley, or across drilled barley, at a foot if perhaps the latter is the best method, as there is less probability of the crop being laid to the damage of the lucern. The quantity of seed-corn should also be small, proportioned to the richness of the land, from one bushel to a bushel and a half, according to the fertility of the soil, another security against the mischief of lodging. If these precautions are taken, it would be presumptuous to say that success must follow, that being always, and in all things, in other hands than ours; seed may prove bad, the fly may eat, and drought prevent vegetation, but barring such circumstances, the farmer may rest satisfied that he has done what can be done, and if he does succeed, the advantage will be unquestionable."

5032. *The quantity of seed*, when the broad-cast method is adopted, is said to be from 15 to 20 lbs. per acre, and from 8 to 12 if drilled. The seed is paler, larger, and dearer than that of clover: it is generally imported from Holland, and great care should be had to procure it plump and perfectly new, as two years old seed does not come up freely. The same depth of covering as for clover will answer.



5033. Lucern may be *transplanted*, and when the soil is very rich and deep, it is said to produce very large plants; but such plants, from the bulk of their stools, are not likely to be so durable as those of a less size, and on the whole, for this and other reasons relative to expense, the plan of transplanting does not seem advisable unless for filling up blanks.

5034. *The after-culture of lucern*, sown broad-cast, consists in harrowing to destroy grass and other weeds; rolling, after the harrowing, to smooth the soil for the scythe, and such occasional top-dressings of manure as the state of the plants may seem to require. Where lucern is drilled, horse-hoeing may be substituted for harrowing, which, as already observed, is the only advantage of that mode of sowing. The harrowing may commence the second year, and the weeds collected should always be carefully removed: light harrows may be used at first, and in two or three years such as are heavier. In succeeding years two harrowings may be required, one early in the spring, and the other at the close of the summer. For these, and especially the last, Arthur Young recommends the use of a harrow of such weight as is sufficient for four horses, and which does not cover a breadth of more than four feet. The mode of hoeing, either by the hand or horse-hoe, or of stirring by the drill harrow, requires no description.

5035. *The top-dressings* given to lucern may be either of the saline or mixed manures. Ashes are greatly esteemed, and also gypsum and liquid manure of any kind. Arthur Young advises to apply dung, in the quantity of about twenty tons to the acre, every five or six years. Kent, however, thinks it a better practice to put a slight coat on annually in the spring season. Some recommend a slight top-dressing sown by hand every spring. The farmer will in this, as in every case, exercise his own judgment, and be guided by the wants of the plants, the return they yield for the expense bestowed on them, and the equable distribution of manure among his other crops.

5036. *The taking of lucern* by mowing for soiling, or hay, or by tethering, hurdling, or pasturing, may be considered as the same as for clover. Lucern frequently attains a sufficient growth for the scythe, towards the end of April, or beginning of the following month; and in soils that are favorable for its culture, will be in a state of readiness for a second cutting in the course of a month or six weeks longer, being capable of undergoing the same operation, at nearly similar distances of time during the whole of the summer season. In this last sort of soil, with proper management, in the drill method, it has been found to rise to the height of a foot and a half in about thirty or forty days, affording five full cuttings in the summer. But in the broad-cast crops, in the opinion of some, there are seldom so many cuttings afforded in the season, three or four being more common, as the growth is supposed to be less rapid than by either of the other modes.

5037. *The application of lucern* is also the same as of clover. The principal and most advantageous practice, in the application of lucern, is that of soiling horses, neat cattle and hogs; but as a dry fodder, it is also capable of affording much assistance, and as an early food for ewes and lambs, may be of great value in particular cases. All agree in extolling it as food for cows, whether in a green or dried state. It is said to be much superior to clover, both in increasing the milk and butter, and improving its flavor. In its use in a green state, care is necessary, not to give the animals too much at a time, especially when it is moist, as they may be hoven or blown with it, in the same way as with clover, and other green food of luxuriant growth.

5038. *The produce of lucern*, cut three times in a season, has been stated at from three to five and even eight tons per acre. In soiling, one acre is sufficient for three or four cows during the soiling season, and a quarter of an acre, if the soil be good for all sorts of large stock, for the same period, or half an acre on a moderate soil. Say, however, that the produce is equal in bulk and value to a full crop of red clover, then, if continued yearly for nine or ten years (its ordinary duration in a productive state), at an annual expense of harrowing and rolling, and a triennial expense of top-dressing, it will be of sufficient value to induce farmers, who have suitable soils and climates, to lay down a few acres under this crop near their home-stalls.

5039. *The nutritive product of lucern*, according to Sir H. Davy, is  $2\frac{3}{10}$  per cent., and is to that of the clovers and saintfoin as 23 to 39. This result does not very well agree with the superior nutritive powers attributed to lucern.

5040. *To save seed*, the lucern may be treated precisely as the red clover, and it is much easier threshed, the grains being contained in small pods, which easily separate under the flail, or a threshing machine, or clover mill.

5041. *The diseases of lucern* appear to be the same as those of clover. In Kent, blight and the slug are its greatest enemies.

SECT. III. *Saintfoin*. — *Hedysarum Onobrychis*, L. *Diadel. Decan.* L. and *Leguminosæ*, J. *L'esparcet*, Fr.; *Espazette*, Ger.; and *Cedrangola*, Ital. (fig. 571.)

5042. *Saintfoin* is a deep rooting perennial with branching spreading stems, compound leaves, and showy red flowers. It is a native of England and many parts of Europe, but never found but on dry warm chalky soils, where it is of great duration. It has been long cultivated in France and other parts of the continent, and as an agricultural plant was introduced from the latter country to England about the middle of the seventeenth century. It has since been a good deal cultivated in the chalky districts; and its peculiar value is, that it may be grown on soils unfit for being constantly under tillage, and which would yield little under-grass. This is owing to the long and descending roots of the saintfoin, which will penetrate and thrive in the fissures of rocky and chalky understrata. Its herbage is said to be equally suited for pasturage or for hay, and that eaten green it is not apt to swell or hove cattle like the clovers or lucern. Arthur Young says, that upon soils proper for this grass no farmer can sow too much of it, and in *The Code of Agriculture* it is said to be "one of the most valuable herbage plants we owe to the bounty of Providence."



5043. There are no *varieties* of the saintfoin, but many other species of the same numerous family that might be cultivated, such, for example, as the French honeysuckle, a biennial, that might be substituted for red clover on rich soils.

5044. *The best soil* for this plant is that which is dry, deep, and calcareous; but it will grow on any soil that has a dry subsoil. Kent thinks that the soils most suited to the culture of this sort of grass are those of the chalky loam, and light sandy or gravelly kinds, or almost any of those of a mixed quality, provided they be not too wet, and have a rocky or hard calcareous bottom to check the roots at the depth of a foot or fifteen inches below the surface, which he, notwithstanding the above, conceives necessary, as the plants are apt to exhaust themselves in running down. And for this reason he considers it as improper for being sown where there is great depth of mould or soil. It is a plant that is asserted by Marshal to afford a large produce even on those soils which are of the poorest quality, and that on such as are of a more rich and friable nature it frequently produces abundant crops. Still, he conceives, that it is only in the calcareous soils, as the dry chalk and limestone, or such as have been well impregnated with that sort of matter, that it succeeds in a perfect manner or becomes durable. The advantages resulting from growing this plant on sandy soils in Norfolk have been already stated (4379.).

5045. *The best preparation* which any soil fit for this plant can undergo, is unquestionably that of trenching; and we have little doubt that in most cases, all things considered, it would be found the cheapest. The usual preparatory culture, however, is the same as for clover, ploughing however, deeper than ordinary, either by means of the trench plough, or, what is better because more simple, by the common plough going twice in the same track. Boys (*Communications to the Board of Agriculture*, vol. iii.) recommends as a preparation for saintfoin; 1st year, pare and burn for turnips, to be eaten on the land by sheep, with the aid of some fodder; 2d, barley, to be sown very early with clover seed; 3d, clover eaten off by sheep; 4th, wheat; 5th, turnips with manure; and, 6th, barley with saintfoin. The corn crops must be carefully weeded, and in particular cleared of charlock. Under this system, the produce has been great, and the ground has been laid down in the highest order with saintfoin, or any other grass calculated for this species of soil.

5046. With respect to the *season of sowing* saintfoin, it may be observed that the earlier it can be put into the soil in the spring the better, as from the greater moisture of such soils there will be a greater probability of their vegetating in a perfect manner. Where the sowing is executed at a late period, and dry weather succeeds, Bannister thinks that much of the seed would be prevented from growing, and the young plants be more exposed to the destruction of the fly; therefore, according to this writer, the sowing of saintfoin seed ought never to be deferred longer than the beginning of March, and that it is still better to complete this work in February. Some, however, suppose it may be deferred to the middle of March without injury.

5047. *The manner of sowing* is almost always broad cast, but it may be sown in drills and even transplanted, though neither of these modes can be recommended. Some advise its being sown with about half the quantity of barley which is usually sown for a full crop, as it may shade and keep it moist during the first summer, and at the same time not injure it from the crop being lighter, which is sometimes the case. Where the barley is drilled the saintfoin may afterwards be put in, in the same manner, but in a contrary

direction. If sown over the wheat it should be harrowed in, and afterwards rolled. In whatever method it is sown, as the seeds are larger than those of many other herbage plants, they should be covered in with more care, and to a somewhat greater depth. By some the ploughing the seed in with a very thin or shallow furrow is recommended. In most cases, especially in all the more light sorts of land in which this sort of crop is grown, the use of the roller may be necessary immediately after the seed is put into the ground. It is the practice in some districts to sow a small portion of clover seed with saintfoin, with the idea of increasing the first year's produce; but as plants of different kinds seldom answer well when grown together, from there being a continual contest in their growth for an ascendancy, it is perhaps a better method to increase the proportion of the seed, without mixing it with that of other sorts. It is, however, supposed by Marshal that such a practice is beneficial in ultimately procuring a fine clean crop of saintfoin upon the land. It is a sort of crop that grows in so perfect a manner in the broad-cast method, that there can seldom be any necessity for having recourse to the drill. It may, however, be cultivated in the latter mode with much success. And in Norfolk, it is the practice with some cultivators to have it drilled at nine inches across the barley crops which have been sown in the same way.

5048. *The quantity of seed in the broad-cast method, which is that mostly employed, is about four bushels the acre, though less is frequently given; but on such soils as are proper for this plant it is always necessary to have a full proportion of seed. By some, however, a much smaller quantity is made use of, and where the drill system is had recourse to, a still smaller proportion is used, as from two to two and a half, or three bushels. It has been observed, that in Lincolnshire, where this plant is much grown, "the common allowance of seed is five bushels to an acre, and that a gentleman south of Lincoln advises the sowing a small quantity of trefoil with it (about four pounds on an acre). The reason for which is, that in that exposed country, the young plants suffer more by the sun in summer than by the frost in winter. Of course the trefoil coming to perfection the first year, and living only three, will be a shelter for the young plants during the first year or two, and die off when the saintfoin wants its room.*

5049. *In the choice of the seed it is the best practice for the cultivator to select it from the best and most abiding plants in his particular soil, as such as is purchased from the seed-shops can rarely be depended upon. A certain method of knowing the goodness of the seed is, by sowing a number of the seeds, and seeing how many plants are produced by them. But the external signs of the seeds being good are, that the husk is of a bright color, and the kernel plump, of a light grey or blue color, and sometimes of a shining black. The seed may be good, though the husk be black, as that is owing sometimes to the letting it receive wet in the field, and not to its being half rotted in the heap. If the kernel be cut across, and appear greenish and fresh, it is a certain sign that it is good. But if it be of a yellowish color, and friable, and looks thin and pitted, they are bad signs. But others observe that the best seed is that which is plump, heavy, bright, and of a yellowish red color, and that it should always be sown while quite fresh, as that which is old, or that has been long kept, never vegetates in a perfect manner. In purchasing seed of this sort it is in general from about three to five shillings the bushel.*

5050. *The after-culture and management of saintfoin consists in occasional dressings with manure, and in the judicious intervention of mowing and pasturing. The first year some farmers do not mow, while others do; but the second year, and in the succeeding summers, a crop of hay may be taken, and the after-grass be fed down with any sorts of stock but sheep, till towards December, care being taken that they do not eat it in too close a manner, as where that is the case, from the largeness of the roots, they may be in danger of injuring the crowns of the plants. In the following autumn there will however be less risk in this respect, and sheep as well as cattle stock may be turned in and kept upon the pastures till they are well eaten down, being always careful to shut them up as early as possible in the beginning of the year. This is the opinion of Kent. And it is supposed that as this sort of herbage is considered to be improved in its taste by being nipped by the frost, it may be a proper practice not to turn stock upon these leys too early in the autumnal season. With this intention it may be advisable to defer it till the latter end of September, when this sort of rouen or after-grass will be found to have much effect in promoting the flow of milk in cows, as well as in forwarding the condition of fattening beasts; great store of feed being still left for sheep. But with this sort of stock they should not be too closely fed down, or the sheep remain too long upon them, as much injury may be sustained by it. It has been suggested that all sorts of cattle stock should be removed by the beginning of the year from these rouens, as much harm might be done by their continuing longer.*

5051. *In top-dressing saintfoin peat-ashes are the best material that can be made use of where they can be procured in sufficient quantity. And other sorts of ashes are likewise found beneficial where*

these cannot be had. They should be applied so as to form a thin, even, regular dressing over the whole surface of the crop. In this view soot has also been found of great utility when spread evenly over such leys about the beginning of January, in the proportion of about twenty-five or thirty bushels to the statute acre. And malt-dust has been employed in the same way with great success and advantage, as shown by Bannister in his *Synopsis of Husbandry*. And it is supposed that where those sorts of top-dressings can be applied every third or fourth year, the saintfoin crops, when well established in the soils, may be preserved in a state of vigorous growth for ten or fifteen years, or more, and the land be considerably improved by the roots striking so deeply into it.

5052. *In taking and using the saintfoin crop*, the same practices may be followed as in taking clover: it may be mown for soiling, or hay, or seed; and eaten on the spot by tethering, hurdling, or common pasturing. In making it into hay it is cut immediately on its coming into full blossom, and as it remains but a short time in this state, as much expedition as possible should be employed both in mowing and making the produce into hay. It is remarked by the author of *The Synopsis of Husbandry*, who resides in a district where the culture of saintfoin is frequent, that of all other hay plants, it requires the least pains in making; when the season is favorable, the hay-makers may follow the scythe, and having turned over the swaths, throw them into wind rows the succeeding day after the crop is mown, when it may be immediately formed into cocks, and the whole crop be fit for carting in a week after it is mown; and though it may appear very green, and the stack when made take on or acquire a considerable degree of heat, there is no danger to be apprehended, provided the weather has been fair during the hay-making; as it is so far from taking harm by heating in the stack, that the contrary state is the most to be feared; and for this reason great care is necessary not to suffer the fodder to continue long either in the swath or in cocks, lest the sun and wind should dry it up too fast, and by exhaling its juices prevent the heating in the stack, and thereby render it of little value. In order to preserve its succulence, in some places they put a number of these cocks together, so as to form large cocks of a size to contain a load in each, and finish the stacks out of the cocks. And it is likewise a practice with many farmers, where the crop is slight, to turn the swaths, and then run them into cocks with a three-pronged barley fork, following with a wooden dew-rake, the head of which is of sufficient width to cover the ground occupied by three or four swaths, in this manner proceeding with the utmost dispatch, saving a deal of labor and expense in the business.

5053. *In regard to the frequency of cutting saintfoin*, it is probable that on the thinner sorts of soils it can seldom be done more than once; but on those of the deeper sorts two crops may sometimes be taken, in the same manner as with clover, care being taken in these cases, that the future growth of the plants be not injured by this means.

5054. *The usual duration of saintfoin*, in a profitable state, is from eight to ten years. It usually attains its perfect growth in about three years, and begins to decline towards the eighth or tenth on calcareous soils, and about the seventh and eighth on gravels. There are instances, however, of fields of saintfoin, which had been neglected and left to run into pasture, in which plants have been found upwards of fifty years from the time of sowing. It has been cultivated upwards of a century on the Cotswold hills, and there roots of it have been traced down into stone quarries from ten to twenty feet in length, and in Germany Von Thaer found them attain the length of sixteen feet. In general the great enemy to the endurance of saintfoin is the grass which accumulates, and forms a close turf on the surface, and thus chokes up the plant.

5055. *The quantity of produce on a medium of soils and cultivation*, may probably be estimated at from about one and a half to two tons the acre. And on the poorer and thinner staple sorts of land, it will perhaps seldom afford less than from a ton to a ton and a half on the acre.

5056. *The nutritive products of saintfoin* are the same as clover; viz.  $3\frac{3}{10}$ , being  $1\frac{6}{10}$  per cent. more than those of lucern.

5057. *In saving seed from saintfoin*, it should remain on the land till the husks become of a somewhat brownish color, and the seeds are perfectly plump and firm, as by these means they will not only be better in their quality, but be in less danger of being injured in the field from the very short time that it will be necessary for them to remain, and also less in danger of being hurt by heating when laid up for future use. It has been stated, that it requires some experience to know of what degree of ripeness it is best to cut the seeded saintfoin; because all its seeds do not ripen at the same time. Some ears blossom before others; every ear begins blossoming at its lower part, and continues to blow gradually upwards for many days; so that before the flower is gone off at the top, the seeds are almost mature at the bottom. By this means, if the cutting be deferred till the top-seeds are quite ripe, the lower, which are the best, would shed and be lost.

5058. *The best time to cut it* is when the greatest part of the seed is well filled, the first blown ripe, and the last blown beginning to be full. The unripe seeds will ripen after cutting, and be, in all respects, as good as those that were ripe before. Some, for want of observing this, have suffered their saintfoin seed to stand till all of it has shed, and been lost in cutting. Saintfoin should never be cut in the heat of the day, while the sun shines out; for then much, even of the unripe seed, will shed in mowing. The right time for this work is the morning or evening, when the dew has rendered the plants supple. When the weather is fine and clear, the saintfoin will soon dry sufficiently in the swaths, without turning them; but if any rain has fallen, and there is a necessity for turning them, it should be done very gently while they are moist, and not two swaths together, as in the other hay made of saintfoin before it has seeded. If the swaths are turned with the handle of the rake, it is best to raise up the ear-sides first, and let the stub-side rest on the ground in turning; but if it is done with

the teeth of the rake, let the stub-side be lifted up, and the ears rested on the earth. If it be cocked at all, the sooner it is done the better; because, if the swaths are dry, much of the seed will be lost in separating them, the ears being entangled together. When moist, the seeds stick fast in the ear; but, when dry, it drops out with the least touch or shaking. It is, however, the best practice, as soon as the proper degree of maturity has been attained by the crop, that it should be mown in as short a time as can possibly be made convenient, and remain exposed in the swath until the upper surface is fully dried, when it must be wholly turned over, but in a very careful manner, so as to prevent the seeds from shedding and being lost, as much as the nature of the work may admit of. When this side has been rendered perfectly dry and crisp in the same way as the other, the crop should either be threshed out upon cloths in the field where it is grown, or laid up in stacks to be afterwards performed when the farmer has more leisure and convenience for the work.

5059. *The work of threshing out the seeds* in this kind of crop is much less troublesome and expensive than in that of the clover kind. In cases where threshing-machines are in use, the business may be executed with great ease and facility in that mode. It has, however, been observed by a late writer, that "when the season is favorable, the practice of threshing it out in the field is probably the most beneficial, as the stems or haulm may be laid up for the purpose of fodder in the stack."

5060. *As the threshing in the field* cannot be done but in very fine weather, and while the sun shines in the middle of the day, the best manner of performing it is to have a large sheet pegged down to the ground, for two men to thresh on with their flails, while two others bring them fresh supplies in a smaller sheet, and two more clear away the hay that has been threshed. The seed is emptied out of the larger sheet, and riddled through a large sieve, to separate it from the chaff and broken stalks; after which it is put into sacks, and carried into the barn to be winnowed. Care should be taken not to let the hay get wet, as in that case it would be spoiled. It is a very important, but difficult matter, to keep the seed that has been threshed in the field, without becoming wet. If it be winnowed immediately, and only a little of it laid amidst a great heap, or put into a sack, it will ferment to such a degree in a few days, that the greatest part of it will lose its vegetative quality. During that fermentation it will be very hot, and smell sour. Spreading it upon a barn-floor, though but seven or eight inches thick, will answer no end, unless it be frequently and regularly turned, until the heating is over; but even this will not make its color keep so bright as that which is well housed, well dried, and threshed in the winter. This last, laid up and unthreshed, will keep without any danger of spoiling, because it does not lie close enough to heat. The best way to preserve the seed threshed in the field is to lay a layer of straw upon a barn-floor, and upon that a thin layer of seed, then another layer of straw, and another layer of seed, and so on alternately. By this means the seed, mixing with the straw, will be kept well, and come out in the spring with as fresh a color as when it was put in.

5061. *In respect to the produce in seed*, it is said to be usually "from about four to five sacks in some districts, but in others it will probably be much less, especially on the shallower sorts of saintfoin soils." But this must obviously be liable to great variation from season, &c.

5062. *The diseases of saintfoin* are few, there being little danger of failure after it has escaped the fly, which attacks the clover tribe in germinating.

#### SECT. IV. *Of various Plants which are or may be cultivated as Herbage and for Hay.*

5063. *Among the inferior herbage plants* which are occasionally cultivated, are burnet, ribwort, chiccory, furze, and spurry. Those which might be cultivated are very numerous, and include several species of vicia, lathyrus, galega, lotus, trifolium, medicago, and others of the native leguminosæ, or pea-like flowering plants; and achillea, alchemilla, cheiranthus, spartium, apium, and a variety of others of different families. With the exception of the chiccory and furze, there are none of these plants that deserve the attention of the professional farmer; ribwort and burnet are occasionally sown; but they are of little value as hay plants, and in most pastures their place might be more advantageously occupied by one or other of the natural grasses. With respect to the other plants enumerated, they have never been tried but by way of experiment, and are only mentioned as resources under peculiar circumstances, and as a field of inquiry and exertion for the amateur cultivator.

5064. *The burnet (Poterium sanguisorba, L. fig. 572.)* is a native plant, a hardy perennial with compound leaves, blood-colored flowers, and a long tap-root. It was originally brought into notice by Roque, a commercial gardener, at Walham-green, near London, who found means to procure the patronage of the Dublin and other societies to this plant, which, being a novelty, attracted the attention, and called forth the eulogies of Arthur Young, and other leading agriculturists of the day. Miller, however, at the time observed, that whoever will give themselves the trouble to examine the grounds where it naturally grows, will find the plants left uneaten by the cattle, when the grass about them has been cropped to the roots; besides, in wet winters and on strong land, the plants are of short duration, and therefore very unfit for the purpose of pasture or hay, nor is the produce sufficient to tempt any persons of skill to engage in its culture.

5065. *Curtis* says of burnet, that it is one of those plants, which has for some years past been attempted to be introduced into agriculture, but not answering the farmer's expectations is now in a great degree laid aside. Cattle are said not to be fond of it; nor is its produce sufficient to answer the expense attending its culture. It is to be lamented that persons do not pay a little attention to the nature of plants before they so warmly recommend them. It seems very unlikely that a small plant, scarcely ever met with but on hilly and chalky ground, and to which cattle in such situations do not show any particular attachment, should afford better, or more copious nourishment, than the clovers and other plants already in use.





5066. According to Boys, in *The Agricultural Survey of Kent*, it affords herbage in the winter and spring months, but is not much liked either by cattle or sheep.

5067. Dr. Anderson reports, that burnet retains its verdure pretty well during the winter months, but affords such scanty crops, as hardly to be worth the attention of the farmer.

5068. A correspondent in the *Museum Rusticum*, a work very favorable to burnet, confesses with reluctance that it is not deserving of any exalted character, but rather the contrary; and that it is in no degree to be compared to the common clover, which is cultivated at half the expense. It appears from some accounts there, that horses will not eat it at all, and that kine frequently will not take it without great reluctance. Its slow growth is also made a great objection: being only about five inches high, and having scarce one head in flower; whilst lucern on the same soil, sown the same day and much thicker, was eighteen or twenty inches in height. It is not meant by this, however, to discourage that laudable spirit of improvement which so happily prevails at present; but to caution such as introduce any new plant, to make themselves well acquainted with its natural history.

5069. Those who wish to cultivate burnet as an herbage and hay plant, may treat it exactly as directed for saintfoin; as a pasture plant it is sown among the grasses in the same way as white or yellow clover. A bushel of seed is commonly sown to an acre.

5070. The ribwort plantain, (*Plantago lanceolata*, L., fig. 573.) is a hardy native with a tuft of long-ribbed leaves springing from the crown of the root, long naked flower-stems, and a long moniliform tap-root. It abounds in dry soils, as do several other species of plantain, especially the *P. midea*. On dry soils it affords little herbage, and is often left untouched by cattle. Curtis, Withering, and other British botanists, speak unfavorably of the ribwort as a pasture herbage; but Haller attributes the richness of the milk in the Swiss dairies to the flavor of this plant, and alchemilla, in the mountain pastures. In rich moist or watered lands, its herbage is more abundant, and its flavor altered, a circumstance not uncommon in the vegetable kingdom, but from which it does not always follow that the plant so altered, is deserving of culture. In conformity with this observation, though the ribwort be a scanty and rejected herbage, on poor dry soils, it is said by Zappa, of Milan, to grow spontaneously in every meadow of Lombardy, especially in those which are irrigated. It vegetates early, flowers at the beginning of May, ripens in five weeks, and is cut with the *poa trivialis*; the height of the leaves is about one foot, and of the stalk a foot and a half; it multiplies itself much by the seed and a little by the roots, which it continues for some time to reproduce. Ribwort is eaten heartily by every sort of cattle, and in particular by cows, who like it most in May, when it has great influence on the milk; as the hay has on the flesh. — Where kept well fed down by stock, there can be no doubt of its being a very good and nourishing pasture plant for both cattle and sheep; but it is by no means adapted for hay, or soiling.



5071. Young says, that he had long before recommended this plant for laying land to grass, and sowed it on his own farm. At the same time he thinks it extravagant to propose dandelion and sorrel, as plants proper for a cow pasture; and conjectures that those plants being found among good ones, have qualities given them, which do not properly belong to them; he is likewise inclined to make the same conjecture in respect to narrow-leaved plantain, ribwort or rib-grass, and should even have preferred dandelion and sorrel to it: but he is cautious of opposing theory to practice.

5072. Dr. Anderson states that narrow-leaved plantain or rib-grass is well liked by horses and cattle, and yields a very good crop upon rich ground tending to dampness, if it is at the same time soft and spongy; but that upon any soil which has a tendency to bind, or upon dry ground, it furnishes a very scanty crop. It has been made use of in some parts of Yorkshire as a summer grass. As an article of pasture for cattle and sheep it is there in high esteem: it is not however well eaten by horses; and as an article of hay it is held to be detrimental to the crop; retaining its sap an unusual length of time; and when fully dry falls into a small compass, or is broken into fragments and left behind in the field.

5073. The culture of the plantain is the same as that of clover; its seed is about the same size, and consequently the same proportion of it will sow an acre.

5074. The chicory (*Chicorium intybus*), wild endive or succory, L. (fig. 34.), has long, thick, perpendicular roots, a tuft of endive or lettuce-looking leaves, and when it shoots into flower its stems rise from one to three feet high, rigid, rough, branched, and clothed with leaves and blue flowers. It is found wild in dry calcareous soils in England and most parts of Europe of similar or greater temperature. It is cultivated in France as an herbage and pasture plant, and in Germany and Flanders for its roots, from which a substitute for coffee is prepared. It was first cultivated in this country about 1780 by Arthur Young, who holds it in very high estimation. It is of such consequence, he says, for different purposes of the farm, that on various sorts of soil the farmer cannot, without its use, make the greatest possible profit. Where it is intended to lay a field to grass for three, four, or six years, in order to rest the land, or to increase the quantity of sheep food, there cannot, he thinks, be any hesitation in using it. There is no plant to rival it. Lucern, says he, demands a rich soil, and will

always be kept as long as it is productive; but upon inferior land it is not an equal object. Upon blowing sands, or upon any soil that is weak and poor and wants rest, there is no plant, he supposes, that equals this. On such sort of blowing poor sandy lands, as many districts abound with, especially in Norfolk and Suffolk, it will yield a greater quantity of sheep food than any other plant at present in cultivation. On fen and bog-lands and peat-soils, it also thrives to much profit. On all land where clover from having been too often repeated is apt to fail, chicory may be substituted to great advantage. It does very well for soiling cattle both lean and fattening. It is of excellent use for those who keep a large stock of swine; and it does exceedingly well in an alternate system of grass and tillage, as it will last four, five, six, and even more years; but it should not be sown with any view of making hay in this climate, though it forms a considerable proportion of many of the best meadows in the south of France and in Lombardy. It has, however, he adds, been objected to, on the grounds of its rising and becoming a vivacious weed in succeeding crops. And if this circumstance be not guarded against, this will, he says, happen; but not more or so much as with lucern. But who, he asks, ventures to forbid chicory culture on account of this quality, which is really founded on its merit: when the land is ploughed, says he, only use a broad sharp share, and harrow in tares for feeding or soiling, or break it up for turnips, and there is an end of the objection.

5075. *The culture of chicory is the same as of clover.* As the plant is grown in gardens for culinary purposes, the seed may be procured in the seed shops, gathered in many places from wild plants, or saved by the grower. It is small, flat, black, and resembling that of lettuce; it should be procured fresh, and from eight to twelve pounds an acre are usually sown. The culture of this plant for its roots has been noticed in giving the outline of the agriculture of Flanders, and will be adverted to in a succeeding Chapter.

5076. *The whin, furze, or gorze, (Ulex europæus, L. fig. 574.),* is a well known shrub, found wild on dry light soils, and in rather hilly situations, in the warmer and more temperate parts of Europe, but not in Sweden, or in Russia, or Poland, north of Cracow and Casan. It has been known as a nourishing food for cattle from a very early period, and has been sown in some parts of England for that purpose and for fuel. Dr. Anderson knows few plants that deserve the attention of the farmer more than the whin. Horses are peculiarly fond of it, so much so that some persons think they may be made to perform hard work upon it, without any feeding of grain; but he thinks it tends more to fatten a horse than to fit him for hard labor, and that therefore some grain should be given with it where the work is severe. Cattle, he says, eat it perfectly well when thoroughly bruised, and grow as fat upon it as upon turnips; but unless it be very well bruised for them, they will not eat it freely, and the farmer will be disappointed in his expectations. Cows that are fed upon it yield nearly as much milk as while upon grass, which is free from any bad taste, and the best winter-made butter he ever saw, was obtained from the milk of a cow that was fed upon this plant. This food should be made use of soon after being prepared. Two bushels, with a proper allowance of hay, have been found to be sufficient for a day for three horses performing the same labor as with corn. It also seemed useful to horses laboring under broken-wind and grease. Poor hungry gravelly soils, which would not have let for five shillings an acre, have also been rendered worth twenty shillings by sowing them with furze-seed, in places where fuel has been scarce, this being frequently used for heating ovens, burning lime and bricks, and also for drying malt; but it is not worth cultivating in countries where fuel of any kind is cheap, or upon such lands as will produce good grass, corn, or other crops employed as the food of animals.

574



5077. *The culture of the whin is thus given by the same author.* "A field of a good dry loamy land, being well prepared, he sowed, along with a crop of barley, the seeds of the whin in the same way as clover is usually sown, allowing at the rate of from fifteen to thirty pounds of seed to the acre. The seeds, if harrowed in and rolled with the barley, quickly spring up and advance under the shelter of the barley during the summer, and keep alive during the winter. Next season, if the field has not a great tendency to run to grass so as to choke them, they advance rapidly after Midsummer, so as to produce a pretty full crop before winter. This you may begin to cut with the scythe immediately after your clover fails, and continue to cut it as it is wanted during the whole of the winter; but it is supposed, that after the month of February the taste of this plant alters, as it is in general believed that after that time horses and cattle are no longer fond of it. He, however, observes, that never having had a sufficiency of whins to serve longer than towards the middle of February, or beginning of March, he cannot assert the fact from his own experience. He has frequently seen horses beating the whins with their hoofs, so as to bruise the prickles, and then eat them, even in the months of April and May; and he says, that sheep which have been used to this food, certainly pick off the blossoms and the young pods at that season, and probably the prickles also, so that it is possible the opinion may only be a vulgar error. This is, he thinks, the best way of rearing whins as a crop for a winter food for cattle or horses. But for sheep, who

take to this food very kindly when they have once been accustomed to it, less nicety is required; for if the seeds be simply sown broad-cast, very thin (about a pound of seed per acre) upon the poorest soils, after they come up the sheep of themselves will crop the plants, and soon bring them into round close bushes, as this animal nibbles off the prickles one by one very quickly, so as not to be hurt by them. Sheep, however, who have not been used to this mode of browsing do not know how to proceed, and often will not taste them; but a few that have been used to the food will, he observes, soon teach all the rest how to use it.

5078. *Another very economical way of rearing whins*, but which he has seen practised rather than experienced himself, is this: let a farm be enclosed by means of a ditch all round, with a bank thrown up on one side, and if stones can be had, let the face of that bank be lined with the stones, from bottom to near the top, this lining to slope backwards with an angle of about sixty or seventy degrees from the horizon. Any kind of stones, even round ones gathered from the land, will answer the purpose very well; upon the top of the bank sow whin-seeds pretty thick, and throw a few of them along the face of the bank. Young plants will quickly appear. Let them grow for two years, and then cut them down by means of a hedge-bill, sloping down by the face of the bank. This mode of cutting is very easy, and as the seeds soon insinuate themselves among the crannies of the stones, the whole face of the bank becomes a close hedge, whose shoots spring up with great luxuriance. If another ditch be made on the other side of the bank, and if this be managed in the same way, and the hedge cut down only once every second year (and in this way it affords very good food for beasts), the inside and outside being cut down alternately, the fence will at all times continue good, as the hedge at the top will at all times be complete. This mode of rearing whins is, he remarks, both convenient and economical. But where stones cannot be obtained for making the facing, the bank very soon moulders down, and becomes unfit for the purposes of a fence. Circumstances have, he says, prevented him from ascertaining what is the weight of the crop that may be thus attained, but he thinks he may safely venture to say, that it is at least equal to that of a crop of green clover; and if it be considered, that this affords a green succulent food during winter, on which cattle can be fattened as well as on cut grass in summer, it will, he thinks, be admitted, that it must be accounted even a more valuable crop than clover. After being cut, he also remarks, that it springs up the following season with greater vigor than before, and in this situation acquires a degree of health and succulence very different from what it is ever observed to possess in its natural state. He has seen shoots of one season near four feet in length. The prickles too are so soft, and the stems so tender, that very little bruising is necessary; indeed horses, that have been accustomed to this food, would eat it without any bruising at all; but cattle, whose mouths seem to be more tender, always require it to be well bruised. How long crops of this sort may continue to be annually cut over, without wearing out, he cannot say, but he believes a long while in favorable circumstances; however, one thing is necessary to attend to in order to guard against its being destroyed: as, during the beginning of the season, nature seems to be solely employed about the great work of fructification only, and it is not till near Midsummer that the whin begins to push forth its wood-bearing branches, which advance with great luxuriance only during the latter part of the season, it may happen, that if care be not taken to have the grass that springs up on the field, before the whin begins to send out its shoots, eaten close down, that grass will acquire such a luxuriance before the young branches of the whin begin to advance, as to overtop them, and choke them entirely. Whoever, therefore, has a field under this particular crop, must, he says, be careful to advert to this circumstance, or if the field be in good heart, he will infallibly lose it. The field therefore should be kept as a pasture, bare as possible during the beginning of the season, and the cattle should only be taken from it when the shoots of the whin are discovered to begin to advance with vigor. Under this management, he presumes, it may be kept for many years, and yield full crops; but unless the mowers be particularly attentive at the beginning, to cut it as low as possible, it will very soon become impossible to cut the field with a scythe, as the stumps will soon acquire so much strength as to break the scythe when it happens to touch them.

5079. *The spurry*, (*Spergula arvensis*, L. fig. 63.) is a diminutive annual weed, on dry sandy corn-lands, in most parts of Europe. In Germany and the Netherlands, it is sown on the corn stubbles, and in the intervals of time that occur between some crops is fed with sheep. It may be sown and reaped in eight weeks, either in autumn or spring. It is said to enrich the milk of cows, so as to make it afford excellent butter; and the mutton fed on it is preferable to that fed on turnips. Hens eat spurry greedily, and it is supposed to make them lay a great number of eggs. Whether in hay, or cut green, or pasture, Von Thaeer observes, it is the most nourishing, in proportion of its bulk, of all forage, and gives the best flavored milk and butter. It has been recommended to be cultivated in England; but it is not likely that such a plant can ever pay the expense of seed and labor in this country, even on the poorest soil, or at all events, as Professor Martyn observes, we have many better plants for such soils.

5080. *The common broom*, (*Spartium scoparium*, L. fig. 575.) is cultivated in the southern parts of France, on the poorer sorts of soil, in the same way as hemp, for the purpose of stripping the bark from it, and converting it into a kind of thread. It is likewise cultivated in these places as a winter-food for sheep, and it is said they eat it with great avidity, preferring it to many other plants. It is, however, liable to produce diseases of the urinary passages, by its diuretic qualities. It has been recommended by Young, to be cultivated in England, as food for sheep and horses, who are said to eat it after they get accustomed to it; also for thatch, ropes, besoms, food for bees, fuel, and burning on the spot to improve the soil. Its culture is the same as that of the whin; but very peculiar, indeed, must be that situation, where its culture is attempted for any of the above purposes. It is a useful protection of game in plantations, from which source abundance may be had for besoms. The Spanish broom, (*S. junceum*, L.



fig. 576.) might be grown perhaps still more advantageously than the common species.

576



5081. *The parsley, (Apium petroselinum, L. fig. 577)* is a well known biennial with a large sweet tap-root. It is a native of Sicily, but endures the British winter like a native plant. It is sown along with clover and grass seeds in some places, and especially in Lincolnshire, as a preventive of the rot in sheep. Fleet, of Hampshire, famous for curing the rot in sheep, cultivates it largely with success; he sows half a bushel to the acre, with a bushel of rye-grass, with spring corn; and he finds that it lasts in the ground till it is permitted to seed. He feeds it constant-

577



ly, it being excellent for sheep, and when suffered to get a-head pigs feed wonderfully upon it in the autumn. After September, it will not, he says, run to seed. When it was ploughed up he obtained good oats. The land was poor, and in the next round of the course, the clover was much the better for the parsley having been sown or the clover omitted; for in a field half parsley, half clover, when the clover came again to be sown, it was excellent on the parsley half, but bad on the clover part. In laying down land to grass, Hoyte, in the fourth volume of *Communications to the Board of Agriculture*, advises the sowing with twelve pounds of white clover, two pounds of red clover, two pecks of rye-grass, and two pounds of parsley to the acre, as the parsley stands two years, and by its diuretic qualities prevents the sheep from dying of the red-water, which too luxuriant clovers are apt to produce. It has also been sown with success in Scotland, where it was greedily eaten by horses, cows, and hogs. The seed requires a longer period to germinate than that of any other agricultural plant, and might probably be advantageously prepared by steeping and turning. It must be fresh, as two year old seed will not grow; it is easily procured by the pound or bushel, from the seedsman, and as easily raised by letting a few drills in a garden shoot into flower stems.

5082. *The wall flower, (Cheiranthus cheiri, L.)* is a well known garden flower, and at the same time a native, and very hardy on dry soils. Like the parsley it is an antiseptic, and has been recommended to be cultivated for the same purposes, and in the same manner.

5083. *The bird's foot trefoil, (Lotus corniculatus, L. fig. 578.)* has been tried as a substitute for white clover on moist lands, and seems to succeed very well, but to have no particular advantages over the clover.

5084. *The oriental bunias, (Bunias orientalis, L. fig. 579 a.)* is a perennial

578



579



plant, with leaves, branches, and its general habit of herbage, not unlike the wild chicory. It is a native of the Levant, and has been cultivated by way of experiment in the

grass garden, at Woburn. It is less productive than chicory, bears mowing well, and affords the same nutriment, in proportion to its bulk, as red clover. (*Agricul. Chem.* p. 374.)

5085. *The yarrow* (*Achillea millefolium*, L. fig. 579 b.), the *common and alpine ladies' mantle* (*Alchemilla vulgaris* and *alpina*, L.), and others have been tried among perennial grasses, sown in parks, with a view to give flavor to milk, butter, mutton, and venison. Sinclair considers yarrow as an essential ingredient of the most fattening and healthy pastures. In all the pastures most celebrated for fattening or dairy produce, which he examined in Devonshire, Lincolnshire, and in the vale of Aylesbury, yarrow was present more or less in every part of the surface. (*Hort. Gram. Wob.* 2d edit. 412.)

## CHAP. VI.

### *Of the cultivated Grasses.*

5086. *The forage or hay and pasture grasses*, of which we are now about to treat, are found clothing the surface of the earth in every zone, attaining generally a greater height, with less closeness at the root in the warm climates; and producing a low, close, thick, dark green nutritive herbage, in the cooler latitudes. The best grass pastures, those which are most productive and nutritive, are such as are found in countries that have least cold in winter, and no excess of heat in summer. Ireland, Britain, and part of Holland and Denmark, may equal or surpass any countries of the world in this respect; but in every zone where, there are high mountains, there are certain positions between the base and summit, where, from the equability of the temperature, turf may be found equal to that in marine islands. It is a singular circumstance in regard to grasses, that in the greater part of North America, the sorts that grow naturally on the plains are almost all annuals, and consequently with the first frost they die, and the ground remains naked till a fresh crop rises from the self-sown seeds next spring. Nearly the same thing may be said of Poland and Russia, excepting on the banks of rivers and on the mountains.

5087. *The universal presence of the forage grasses*, and the rapidity with which all soils become covered with them when left uncultivated, is the obvious reason why their systematic selection and culture is but of recent date. Though the Romans cultivated clovers, and were careful of their meadows, it does not appear that the seeds of the proper grasses were collected and sown by them. None of the agricultural writers, from Peter of Bologna to Parkinson in 1640, say a word about sowing grasses, though they all mention clover and lucern. This branch of culture appears to have originated in England about the middle of the seventeenth century, and the grass made choice of was the rye-grass. The first mention made of it for cultivation is in Dr. Plot's *Oxfordshire*, printed in 1677. "They have lately sown," says he, "rye-grass, or the gramen lolliceum, by which they improve any cold, sour, clay-weeping ground, for which it is best, but good also for drier upland grounds, especially light stony or sandy land, which is unfit for saintfoin. It was first sown in the children parts of Oxfordshire, and since brought nearer Oxford by one Eustace, an ingenious husbandman of Islip, who, though at first laughed at, has since been followed even by those very persons that scorned his experiment." The first grass tried after rye-grass, appears to have been the *Pleum pratense* by Rocque of Walham Green, about 1760. Soon after the seed of cock's-foot grass was introduced from Virginia, under the name of orchard-grass, by the Society of Arts (*Ann. Reg.* 1765, 141.); fox-tail was tried at a later period, from the suggestions of Stillingfleet and Curtis. 5088. *Stillingfleet*, about 1759, drew the attention of the reading agriculturist to the selection of different species of grasses; as did Dr. Anderson about the same time, and Swayne (*Gramina Pascula*), and Curtis (*Observations on British Grasses*), soon afterwards. The origin of this attention to grasses and native plants may be traced to the practice of forming local floras by botanists, and especially to the *Flora Suecica* of Linnæus; and the *British Floras* of Hudson, Withering, Lightfoot, Smith, &c. in which the medical and economical properties of the plants were mentioned; and, in imitation of Linnæus, particular notice taken of the animals which fed upon them.

5089. *John Duke of Bedford* made the latest and most laborious efforts towards attaining a knowledge of the comparative value of all the British and some foreign grasses worth cultivating. The result is given in an appendix to Sir H. Davy's *Agricultural Chemistry*, and more at large in Sinclair's *Hortus Gramineus Woburnensis*, 8vo. 2d edit. 1825, and as it is of considerable interest, we shall afterwards present an abstract.

5090. *With respect to the general culture of grasses*, though no department of agriculture is more simple in the execution, yet, from the nature of grasses, considerable judgment is required in the design. Though grasses abound in every soil and situation, yet, all the species do not abound in every soil and situation indifferently. On the contrary, no class of perfect plants are so absolute and unalterable in their choice in this respect. The creeping-rooted and stoloniferous grasses will grow readily on most soils; but the fibrous-rooted species, and especially the more delicate upland grasses, require particular attention as to the soil in which they are sown; for in many soils they will either not come up at all, or die away in a few years, and give way to the grasses which would naturally spring up in such a soil when left to a state of nature. Hence in sowing down lands for permanent pasture, it is a good method to make choice of those grasses which thrive best in adjoining and similarly-circumstanced pastures for a part of the seed; and to mix with these what are considered the very best kinds.

5091. *New and excellent varieties* of many of the grasses, especially, those used or fit to be used in the convertible husbandry, might no doubt be obtained by selection and cross breeding, and it is much to be wished that this were attempted by cultivators. — The grasses to be here treated of may be classed as tall sorts, or those best fitted for hay; and dwarf grasses, or those fit only for pasturage: those experimented on at Woburn will next be noticed.

### SECT. I. *Of the tall growing or Hay Grasses.*

5092. *The hay grasses* for the purposes of agriculture may be advantageously divided into those of temporary, and those of permanent duration.

SUBJECT. I. *Of tall or Hay Grasses of temporary Duration.*

5093. *The most valuable of this division* are the biennial, or, as it is commonly but erroneously called, the annual and superbiennial rye-grass (fig. 580 a) the cock's-foot grass (b), and woolly soft grass (c). Where a crop of hay is desired within the year, it is necessary to resort to such grasses as are annuals in the strict sense of the word, and none can be better for this purpose than the common oat, cut and made into hay when it comes into flower. Next in order may be mentioned the other cereal grasses and the annual varieties of bromus: the latter, however, are very coarse grasses, though prolific in culm.

5094. *The biennial rye-grass* (*Lolium perenne*, var. *biennis*, L.) is well known, as being universally sown, either with or without one crop of hay the succeeding season. It attains a greater height, and produces a longer, broader spike of flowers, than the perennial rye-grass, and the produce in hay is considered greater than that of any other annual grass, equally palatable to cattle. It prefers a rich loamy soil, but will grow on any surface whatever, not rock or undecayed bog.

5095. *The perennial rye-grass* (*Lolium perenne*, L. *Ivraie vivace*, Fr.; *Daurende Lolche*, Ger.; and *Loglio vivace*, Ital.) differs from the other in being of somewhat smaller growth, and in abiding for several years, according to the variety and the soil and culture. Many consider this grass coarse, benty, and very exhausting to the soil; but after all the experiments that have been made on the other grasses, none have been found to equal it for a course of mowing and pasturing for two, three, or seven years. It is sown in Italy, and especially in Lombardy, and also in France and Germany, along with clover, for the same purposes as in this country; and, as Von Thier has remarked, though some have tried other species, both in these countries and in England, they have in the end returned to rye-grass. When intended as a pasture-grass, if stocked hard, and when for hay, if mown early, the objections to it are removed. (*Code of Agriculture*.) G. Sinclair says the circumstance of its producing abundance of seed, which is easily collected, and vegetates freely on any soil, its early perfection and abundant herbage the first year, which is much relished by cattle, are the merits which have upheld it to the present day, and will probably for some time to come continue it a favorite grass among farmers. But the lattermath is inconsiderable, the plant impoverishes the soil in a high degree if not cut before the seed ripens. When this is neglected, the field after midsummer exhibits only a brown surface of withered straws. Let the produce and nutritive powers of rye-grass be compared with those of the cock's-foot-grass, and it will be found inferior nearly in the proportion of 5 to 18; to meadow fox-tail of 5 to 12; and to meadow fescue of 5 to 17. (*Hort. Gram. Wob.* 2d edit. 215. and see § 5100.) In a subsequent page he observes, "The new varieties, however, of this species of grass, which have been discovered of late years, remove in a considerable degree the serious objections which applied to the common rye-grass" (*Ib.* 412.) The varieties alluded to are all perennial, and as under:

*Slender rye-grass*, common in dry impoverished pasture land.

*Compound or broad spiked rye-grass*, found in rich soils, long under grass, and chiefly in beaten parts, as cart-ways, &c. It has a short broad spike, crowded with spikelets at the top.

*Pacey's rye-grass*, found in rich meadow lands, and introduced by Pacey, a cultivator in the uplands of Staffordshire; spike nearly upright, spikelets shorter than in the compound r. g. the stem furnished with long leaves, and the root leaves arge and numerous. Sinclair considers this the most valuable variety of the rye-grass.

*Whitworth's rye-grass*, introduced by G. Whitworth, Esq.

All the above, excepting the two first, are excellent varieties. Pacey's and Russel's are considered the best.

5096. *The proportional value* which the grass at the time of flowering bears to that at the time the seed is ripe, is as 10 to 11. The proportional value which the grass of the lattermath bears to that at the time of flowering, is as 4 to 10, and to that at the time the seed is ripe, as 4 to 11.

5097. *The seed of perennial rye-grass* is not to be distinguished from that of the annual variety. It may be collected by hand, in most parts of Britain, from old pastures, and a considerable quantity is annually so got in Kent and Sussex. It is also grown purposely for seed in England and Scotland. Formerly it was the practice for farmers to collect the seed which dropped from the hay used by their horses; but rye-grass, grown for hay, is now cut by all judicious farmers, when it is just coming into flower; and therefore to collect the glumes or empty husks can be of no use as seed. It has also been a common practice, in regard to rye-grass, to let the mixed crop of that and clover stand till the seeds of the former have attained a considerable degree of ripeness, when it is cut down and made into hay, in the usual manner; and the seeds of the rye-grass are separated by the use of the flail, commonly before the hay is put into the field-ricks. Sometimes, when but a small quantity is wanted, the hay is merely shaken well upon a cloth, when it is



building in the stack-yard; or afterwards in the stable-loft, before it is put into the horse's racks. But in all of these methods, in order to obtain good seed, the clover must remain uncut beyond the proper season; and it is thus materially injured in quality, while the value of the rye-grass seed, in such a crop, is merely a secondary consideration.

5098. *When seed is the principal object of the culture of rye-grass, it ought not to be mixed with clover at all, though it may be sown along with any of the kinds of corn, and treated the year after in every respect as a crop of corn; bound up in sheaves, built in stacks, threshed with the flail, and dressed by the winnowing-machine in the same manner.*

5099. *The difficulty of distinguishing between the annual and perennial varieties of rye-grass has led to the practice, in some places, of cutting or pasturing the first year's crop, and taking a crop for seed the second year. If the growth of the rye-grass plants be close and vigorous the second year, there is reason to be satisfied that the seed is of the perennial variety; and though red clover has been sown with the rye-grass, a great part of it disappears by that time, and forms but a small portion of the second year's cutting. (Sup. Encyc. Brit. art. Agr.)*

5100. *The cock's-foot grass (Dactylis glomerata, L. fig. 580 b) is an imperfect perennial, and grows naturally on dry sandy soils. This grass may be known by its coarse appearance, both of the leaf and spike, and also by its whitish green hue. One writer says, he has cultivated it largely and to his satisfaction on wet loams on a clay marl bottom, upon which the finer grasses are apt to give way in a few years to the indigenous produce. If suffered to rise high, it is very coarse; but fed close, is a very valuable sheep pasture. He has sown two bushels an acre, and 10 lbs. Common red clover; and when the clover wears out, the grass fills the lands and abides well in it. It grows well in winter. It has been found highly useful as an early sheep feed. It is early, hardy, and productive, but is a coarser plant than rye-grass, and requires even greater attention in regard to being cut soon, or fed close. It does best by itself, and the time of its ripening being different from that of clover, it does not suit well to be mixed with that plant. The pasturage it affords is luxuriant, and particularly agreeable to sheep. It is cultivated to a great extent, and with astonishing success at Holkham. The quantity of sheep kept upon it, summer and winter, is quite surprising; and the land becomes renovated by laying two or three years under this grass, and enriched by the manure derived from the sheep. A field, in the park at Woburn, was laid down in two equal parts, one part with rye-grass and white clover, and the other part with cock's-foot and red clover: from the spring till midsummer, the sheep kept almost constantly on the rye-grass; but after that time they left it, and adhered with equal constancy to the cock's-foot during the remainder of the season. In The Code of Agriculture, (p. 497. third edit.) it is stated that Sinclair, of Woburn, considers "no grass so well suited for all purposes as cock's-foot;" and in the second edition of H. Gramineus Woburnensis, it is observed, that if one species only is thought preferable to another in the alternate husbandry, that species is the Dactylis glomerata, from its more numerous merits. But a certain supply of the most nutritious herbage throughout the season will be in vain looked for from any one species of grass, but only where nature has provided it in a combination of many. None appear better fitted for mixing with Dactylis than Festuca duriuscula and pratensis, Poa trivialis, Holcus avenaceus, Phleum pratense, Lolium perenne, and white clover. "A combination thus formed, of three parts cock's-foot, and one part of these species just mentioned, will secure the most productive and nutritive pasture in alternation with grain crops, on soils of the best quality; and even on soils of an inferior nature, under the circumstances of unfavorable seasons, will afford nutritive herbage, when otherwise the land would have been comparatively devoid of it, if one species of grass only had been employed." (Hort. Gram. Wob. 2d edit. 414.)*

5101. *The proportional value which the grass at the time of flowering bears to that at the time the seed is ripe, in as 5 to 7 nearly. The proportional value which the grass of the lattermath bears to that at the time of flowering, is as 6 to 10; and to that at the time the seed is ripe, as 6 to 14. Sixty-four dr. of the straws at the time of flowering afford of nutritive matter 1.2 dr. The leaves or lattermath, and the straws simply, are therefore of equal proportional value; a circumstance which will point out this grass to be more valuable for permanent pasture than for hay. The above details prove, that a loss of nearly one-third of the value of the crop is sustained, if it is left to the period when the seed is ripe, though the proportional value of the grass at that time is greater, i. e. as 7 to 5. The produce does not increase if the grass is left growing after the period of flowering, but uniformly decreases; and the loss of lattermath, (from the rapid growth of the foliage after the grass is cropped) is very considerable. These circumstances point out the necessity of keeping this grass closely cropped, either with the scythe or cattle, to reap the full benefit of its merits.*

5102. *The woolly soft grass (Holcus lanatus, L. fig. 580 c) is an imperfect perennial, and rather late flowering grass, of a soft unsubstantial appearance, and found chiefly in poor dry soils. It is, however, a very common grass, and grows on all soils, from the richest to the poorest. It affords abundance of seed, which is light, and easily dispersed by the wind. It was cultivated at Woburn on a strong clayey loam, and the proportional value which the grass at the time the seed is ripe, bears to that at the time of flowering, is as 11 to 12. Young, of Essex, observes of this grass, that it flourishes well on any moist soil, and should be sown chiefly with a view to sheep, for it is not equally good for other stock: many acres of it have been cultivated on his farm for sheep, and it has answered greatly when kept close fed. Marshal, in his Midland Counties, mentions it as a good grass for cows and other cattle, but bad for horses. In his Rural Economy of Yorkshire, he, however, condemns it in toto.*

5103. *According to Sinclair, of Woburn, "it appears to be generally disliked by all sorts of cattle. The produce is not so great as a view of it in the fields would indicate; but being left almost entirely untouched by cattle, it appears as the most productive part of the herbage. The hay which is made of it, from the number of downy hairs which cover the surface of the leaves, is soft and spongy, and disliked by cattle in general." The Woburn experiments lead to the conclusion that the holcus mollis is a better hay plant than the species here noticed; but as that is a more durable perennial it is less fitted for the temporary purposes of the grasses of this section.*

5104. With respect to the culture of these grasses, it may be considered as the same as that given to rye-grass, as discussed when treating of clover and rye-grass (5002.). The seeds of all of them are sold by the principal seedsmen, or may be gathered on grass-fields, or hedge wastes, by women or children at an easy rate.

SUBJECT. 2. *Of tall or Hay Grasses of permanent Duration.*

5105. No permanent grass has been found equal to the rye-grass for the purposes of convertible husbandry, but others have been selected which are considered superior for hay meadows. The principal of these are the fescue, fox-tail, and meadow-grass. Agriculturists, indeed, are not all agreed on the comparative merits of these grasses with rye-grass, but there are none who do not consider it advisable to introduce a portion of each, or most of these species along with rye-grass, in laying down lands to permanent pasture. The nutritive products of these grasses, of perennial rye-grass, and of that singular grass fiorin, are thus given by Sir H. Davy :

Systematic name.	English name.	Whole quantity of soluble or nutritive matter.	Mucilage or starch.	Saccharine matter or sugar	Gluten or albumen.	Extract or matter rendered insoluble during evaporation.
<i>Festuca loliacea</i> (fig. 581 c)	Spiked fescue grass	19	15	2	—	2
<i>Holcus odoratus</i> -	Sweet-scented soft grass	82	72	4	—	6
<i>Anthoxanthum vernalis</i> -	Sweet-scented vernal grass	50	43	4	—	3
<i>Alopecurus pratensis</i> (d)	Meadow fox-tail grass	33	24	3	—	6
<i>Poa fertilis</i> (e) -	Fertile meadow grass	78	65	6	—	7
<i>trivialis</i> (f) -	Roughish meadow grass	39	29	5	—	6
<i>Cynosurus cristatus</i> -	Crested dog's-tail grass	35	28	3	—	4
<i>Lolium perenne</i> -	Perennial rye-grass	39	26	4	—	5
<i>Agrostis stolonifera</i> -	Fiorin	54	46	5	1	2
	Fiorin cut in winter	76	64	8	1	3

581



5106. *Of the fescue grass* there are three species in the highest estimation as meadow hay grasses, viz. the meadow, tall, and spiked fescue. (fig. 581 a, b, c.) The *F. pratensis* (a), or the meadow or fertile fescue grass, is found in most rich meadows and pastures in England, and is highly grateful to every description of stock. It is more in demand for laying down meadows than any other species excepting the rye-grass. By the Woburn experiments, the value of this grass at the time the seed is ripe, is to that of the grass at the time of flowering, as 6 to 18. The loss which is sustained by leaving the crop of this grass till the seed be ripe is very great. That it loses more of its weight in drying at this stage of growth, than at the time of flowering, perfectly agrees with the deficiency of nutritive matter in the seed crop, in proportion to that in the flowering crop: the straws being succulent in the former, they constitute the greatest part of the weight; but in the latter they are comparatively withered and dry, consequently the leaves constitute the greatest part of the weight. It may be observed here, that there is a great difference between straws or leaves that have been dried after they were cut in a succulent state, and those which are dried by nature while growing. The former retain all their nutritive powers; but the latter, if completely dry, very little, if any.

5107. *The tall or infertile fescue grass* (*Festuca elatior*, E. B. b.) is closely allied to the *festuca pratensis*, from which it differs in little, except that it is larger in every respect. The produce is nearly three times that of the *F. pratensis*, and the nutritive powers of the grass are superior, in direct proportion, as 6 to 8. The proportional value which the grass at the time the seed is ripe, bears to that at the time of flowering, is as 12 to 20. The proportional value which the grass of the lattermath bears to that of the crop, is as 16 to 20; and to that at the time the seed is ripe, as 12 to 16 inverse. Curtis observes, that as the seeds of this plant, when cultivated, are not fertile, it can only be introduced by parting its roots and planting them out; in this there would, says he, be no great difficulty, provided it were likely to answer the expense,



which he is strongly of opinion it would in certain cases; indeed he has often thought that meadows would be best formed by planting out the roots of grasses, and other plants, in a regular manner; and that, however singular such a practice may appear at present, it will probably be adopted at some future period: this great advantage would, he says, attend it, noxious weeds might be more easily kept down, until the grasses and other plants had established themselves in the soil.

5108. *The spiked fescue grass*, or darnel fescue grass, (*Festuca loliacea*, L. c), resembles the rye-grass in appearance, and the tall fescue grass in the infertility of its seeds. It is considered as superior to rye-grass either for hay or permanent pasture, and improves in proportion to its age, which is the reverse of what takes place with the rye-grass.

5109. *The meadow fox-tail grass* (*Alopecurus pratensis*, d) is found in most meadows, and when the soil is neither very moist nor very dry, but in good heart, it is very productive. It also does well on water meadows. Sheep and horses seem to have a greater relish for this grass than oxen. In the Woburn experiments, it was tried both on a sandy loam and a clayey loam, and the result gave nearly three-fourths of produce greater from a clayey loam than from a sandy soil, and the grass from the latter is comparatively of less value, in proportion as 4 to 6. The straws produced by the sandy soil are deficient in number, and in every respect less than those from the clayey loam; which will account for the unequal quantities of the nutritive matter afforded by them; but the proportional value in which the grass of the lattermath exceeds that of the crop at the time of flowering, is as 4 to 3: a difference which appears extraordinary, when the quantity of flower-stalks which are in the grass at the time of flowering is considered. In the anthoxanthum odoratum the proportional difference between the grass of these crops is still greater, nearly as 4 to 9; in the poa pratensis they are equal; but in all the latter flowering grasses experimented upon, the flowering straws of which resemble those of the alopecurus pratensis, or anthoxanthum odoratum the greater proportional value is always, on the contrary, found in the grass of the flowering crop. Whatever the cause may be, it is evident that the loss sustained by taking the crops of these grasses at the time of flowering is considerable. The proportional value which the grass at the time of flowering bears to that at the time the seed is ripe, is as 6 to 9. The proportional value which the whole of the lattermath crop bears to that at the time the seed is ripe, is as 5 to 9, and to that at the time of flowering, proportionably as 13 to 24. Next to the fescue, this grass is in the greatest reputation for laying down mowing grounds; but it is unfortunately subject to the rust in some situations.

5110. Of the *meadow grass* there are two species in esteem as hay plants, the smooth-stalked, and roughish. These plants compose the greater part of the celebrated Orcheston meadows near Salisbury, and also of the meadows near Edinburgh.

5111. *The great or smooth-stalked meadow grass*, the spear grass of America, (*Poa pratensis*, e) is distinguished by its height, smooth stem, and creeping roots. According to Sole it is the best of all the grasses: its foliage begins to shoot and put on a fine verdure early in the spring, but not so soon as some other grasses. Every animal that eats grass is fond of it; while it makes the best hay, and affords the richest pasture. It abounds in the best meadows about Laycock and Chippenham, and has the valuable property of abiding in the same land, while most other grasses are continually changing. According to some it delights in rather a dry than a moist soil and situation, on which account it keeps its verdure better than most others in dry seasons; but it thrives most luxuriantly in rich meadows.

5112. *By the Woburn experiments*, the proportional value in which the grass of the lattermath exceeds that of the flowering crop, is as 6 to 7. The grass of the seed-crop, and that of the lattermath, are of equal value. This grass is, therefore, of least value at the time the seed is ripe; a loss of more than one-fourth of the value of the whole crop is sustained if it is not cut till that period: the straws are then dry, and the root-leaves in a sickly decaying state: those of the lattermath, on the contrary, are luxuriant and healthy. This species sends forth flower-stalks but once in a season, and those being the most valuable part of the plant for the purpose of hay, it will, from this circumstance, and the superior value of the grass of the lattermath, compared to that of the seed-crop, appear well adapted for permanent pasture. It was of this grass that the American prize bonnet, in imitation of Leghorn, was manufactured by Miss Woodhouse.

5113. *The roughish meadow grass* (*Poa trivialis*, L. f) delights in moist, rich, and sheltered situations, when it grows two feet high, and is very productive. By the Woburn experiments, it appears that the proportional value in which the grass of the seed-crop exceeds that at the time of flowering, is as 8 to 11. The proportional value by which the grass of the lattermath exceeds that of the flowering crop, is as 8 to 12, and that of the seed crop as 11 to 12. Here then is a satisfactory proof of the superior value of the crop at the time the seed is ripe, and of the consequent loss sustained by taking it when in flower; the produce of each crop being nearly equal. The deficiency of hay in the flowering crop, in proportion to that of the seed crop, is very striking. Its superior produce, the highly nutritive powers which the grass seems to possess, and the season in which it arrives at perfection, are merits which distinguish it as one of the most valuable of those grasses, which affect moist rich soils, and sheltered situations; but on

dry exposed situations, it is altogether inconsiderable; it yearly diminishes, and ultimately dies off, not unfrequently in the space of four or five years.

5114. The above are *six of the best British grasses*, for either dry or watered meadows. The seeds of the meadow fescue, fox-tail, and smooth and rough meadow grass, may be had from the seedsmen, and they are sown in various proportions with the clovers and rye-grass. The seeds of the two sorts of meadow grass are apt to stick together, and require to be well mixed with the others before being sown. The tall and spiked fescue grass, having a number of barren flowers, are not prolific in seeds, and they are therefore seldom to be got at the seed shops; though they may occasionally be had there gathered from plants in a wild state.

5115. As *hay grasses*, adapted for particular soils and situations, the cat's-tail or Timothy, floating fescue, and fiorin grass, have been recommended; but it cannot be said that the opinions of cultivators are unanimous in their favor.

5116. *The cat's-tail, or Timothy grass*, (*Phleum pratense*, L. fig. 582 a) is a native plant,



and found both in dry and moist soils. It was first brought into notice by Timothy Hudson, about 1780, who introduced it from Carolina, where it was in great repute. On moist rich soils it is a prolific grass, but late; on dry soils it is good for little, and for cultivation in any way is disapproved of by Withering, Swaine, Curtis, and others, as having no properties in which it is not greatly surpassed by the *alopecurus pratensis*. The Woburn experiments, however, present this grass as one of the most prolific for hay. The nutritive matter afforded by 64 drachms of the straws, was 7 drachms. The nutritive powers of the straws simply, therefore, exceed those of the leaves, in proportion as 28 to 8; and the grass, at the time of flowering, to that at the time the seed is ripe, as 10 to 23; and the lattermath, to the grass of the flowering crop, as 8 to 10. The comparative merits of this grass will appear from the above particulars to be very great; to which may be added the abundance of fine foliage that it produces early in the spring. In this respect it is inferior to the *poa fertilis*, and *poa angustifolia* only. The value of the straws at the time the seed is ripe, exceeds that of the grass at the time of flowering, as 28 to 10, a circumstance which increases its value above many others; for by this property its valuable early foliage may be cropped, to an advanced period of the season, without injury to the crop of hay, which in other grasses which send forth their flowering straws early in the season would cause a loss of nearly one half of the value of the crop, as is clearly proved by former examples; and this property of the straws makes the plant peculiarly valuable for the purpose of hay.

5117. *The floating fescue grass*, (*Festuca fluitans*, b) is found in rich swamps, especially in Cambridgeshire, where it is said to give the peculiar flavor to Cottenham and Cheddar cheese. It is also found in ditches and ponds in most parts of the country. It is greedily devoured by every description of stock, not excepting hogs and ducks, and geese eagerly devour the seeds, which are small, but very sweet and nourishing. They are collected in several parts of Germany and Poland, under the name of Manna-seeds (*Schwaden*), and are esteemed a delicacy in soups and gruels. When ground to meal, they make bread very little inferior to that from wheat. The bran is given to horses that have the worms; but they must be kept from water for some hours afterwards. Geese, and other water-fowl, are very fond of the seeds. So also are fish; trout, in particular, thrive in those rivers where this grass grows in plenty. It has been recommended to be sowed on meadows that admit flooding; but Curtis justly remarks, that the flote-fescue will not flourish except in land that is constantly under water, or converted into a bog or swamp.

5118. *The water meadow grass*, (*Poa aquatica*, c) is found chiefly in marshes, but

will grow on strong clays, and yield, as the Woburn experiments prove, a prodigious produce, flowering from June to September. It is one of the largest of our grasses. In the fens of Cambridgeshire, Lincolnshire, &c. immense tracts, that used to be overflowed, and produce useless aquatic plants, and though drained by mills, still retain much moisture, are covered with this grass, which not only affords rich pasturage in summer, but forms the chief part of their winter fodder. It has a powerfully creeping root; and bears frequent mowing well. It is sometimes cut thrice in one season near the Thames. It grows not only in very moist ground, but in the water itself; and with cat's-tail, burr-reed, &c. soon fills up ditches, and occasions them to require frequent cleansing. In this respect it is a formidable plant, even in slow rivers. In the Isle of Ely they cleanse these by an instrument called a *bear*, which is an iron roller, with a number of pieces of iron, like small spades, fixed to it; this is drawn up and down the river by horses walking along the bank, and tears up the plants by the roots, which float, and are carried down the stream. The grass was, however, cultivated at Woburn on a strong tenacious clay, and yielded considerable produce.

5119. *The florin grass (Agrostis stolonifera, d)* is a very common grass both in wet and dry, rich and poor situations. Few plants appear to be more under the influence of local circumstances than this grass. On dry soils it is worth nothing; but on rich marl soils, and in a moist soil, if we may put confidence in the accounts given of its produce in Ireland, it is the most valuable of all herbage plants. It was first brought into notice by Dr. Richardson, in 1809, and subsequently extolled, and its culture detailed in various pamphlets by the same gentleman. It appears to be exclusively adapted for moist peat soils or bogs. In *The Code of Agriculture*, it is said, "On mere bogs, the florin yields a great weight of herbage, and is, perhaps, the most useful plant that bogs can produce." According to Sir H. Davy, the florin grass, to be in perfection, requires a moist climate or a wet soil; and it grows luxuriantly in cold clays unfitted for other grasses. In light sands, and in dry situations, its produce is much inferior as to quantity and quality. He saw four square yards of florin grass cut in the end of January, in a meadow exclusively appropriated to the cultivation of florin, by the Countess of Hardwicke, the soil of which is a damp stiff clay. They afforded twenty-eight pounds of fodder, of which one thousand parts afforded sixty-four parts of nutritive matter, consisting nearly of one-sixth of sugar, and five-sixths of mucilage, with a little extractive matter. In another experiment, four square yards gave twenty-seven pounds of grass. Lady Hardwicke has given an account of a trial of this grass; wherein twenty-three milch cows, and one young horse, besides a number of pigs, were kept a fortnight on the produce of one acre. On the Duke of Bedford's farm, at Maulden, florin hay was placed in the racks before horses, in small distinct quantities, alternately with common hay; but no decided preference for either was manifested by the horses in this trial.

5120. There are *other species of agrostis*, as the *A. palustris* and *repens*, and some varieties of the *A. stolonifera*, that on common soils are little different in their appearance and properties from florin. Of one of these, the narrow-leaved creeping bent (*A. stolonifera*, var. *angustifolia*), the following remarks are made in the account of the Woburn experiments. "From a careful examination of the creeping-bent with narrow leaves, it will doubtless appear to possess merits well worthy of attention, though perhaps not so great as has been supposed, if the natural place of its growth and habits be impartially taken into the account. From the couchant nature of this grass, it is denominated couch-grass, by practical men, and from the length of time that it retains the vital power, after being taken out of the soil, it is called squitch, quick, full of life, &c."

5121. *The culture of florin* is different from that of other grasses. Though the plant will ripen its seeds on a dry soil, and these seeds being very small, a few pounds would be sufficient for an acre, yet it is generally propagated by stolones or root-shoots. The ground being well pulverised, freed from weeds, and laid into such beds or ridges as the cultivator may think advisable; small drills an inch or two deep, and six or nine inches asunder, are to be drawn along its surface, with a hand or horse-hoe, or on soft lands by the hoe-rake. In the bottom of these drills, the florin shoots (whether long or short is of no consequence) are laid in lengthways, so as their ends may touch each other, and then lightly covered with a rake, and the surface rolled to render it fit for the scythe. In six months the whole surface will be covered with verdure, and if the planting be performed early in spring, a large crop may be had the same autumn. Any season will answer for planting, but one likely to be followed by showers and heat is to be preferred. Those who wish to cultivate this grass will consult Dr. Richardson's *New Essay on Fiorin Grass* (1813), and also *The Farmer's Magazine* for 1810-14. Our opinion is, that neither florin, Timothy, or floating fescue, are ever likely to be cultivated in Britain; though the two last may perhaps succeed well on the bogs and moist rich soils of Ireland, where, to second the influence of the soil, there is a moist warm climate.

5122. A number of *other species of tall grasses*, well adapted for meadows and hay-making, might be here enumerated; but we have deemed it better to treat only of the most popular sorts, of which seeds may be purchased, all the others of any consequence will be found in a tabular view (Sect. III.), accompanied by a summary statement of their products, in hay and aftermath, nutritive matter, and general character.

5123. *The preparation of the soil, and sowing of the usual meadow grasses*, differs in nothing from that of clover and rye-grass already given; the after treatment of dry meadows, including the making of natural hay, will be found in the succeeding Chapter on the management of grass-lands, and that of watered meadows was naturally given when treating of their formation. (4053.)

## SECT. II. Grasses chiefly adapted for Pasturage.

5124. Of pasturage grasses we shall make a selection of such as have been tried to some extent, and of which the seeds are in the course of commerce. On soils in good condition, and naturally well constituted, no better grasses can be sown for pasturage than those we have described as tall grasses for hay-meadows; but for early and late pasturage, and secondary soils, there are others much more suitable.

5125. The pasture grasses for early pasturage on all soils, are the anthoxanthum odoratum, holcus odoratus, avena pubescens, and poa annua.

5126. The pasture grasses for late herbage on all soils are chiefly the different species of agrostis and phleum.

5127. The pasture grasses for poor or secondary soils are the cynosurus cristatus, festuca duriuscula and ovina, poa compressa, cristata, and angustifolia.

5128. The grasses that afford most nutritive matter in early spring, are the fox-tail grass and the vernal grass; the former has been already mentioned as one of the best hay-grasses.

5129. The sweet-scented vernal grass, (*Anthoxanthum odoratum*, fig. 583 a), is common



in almost all pastures, and is that which gives the fragrance to natural or meadow-hay. It is chiefly valuable as an early grass, as, though it is eaten by stock, it does not appear to be much relished by them. From the Woburn experiments, it appears that the smallness of the produce of this grass renders it improper for the purpose of hay; but its early growth, and the superior quantity of nutritive matter which the lattermath affords, compared with the quantity afforded by the grass at the time of flowering, causes it to rank high as a pasture-grass, on such soils as are well fitted for its growth; such are peat-bogs, and lands that are deep and moist.

5130. The downy oat grass, (*Avena pubescens*, b), according to the Woburn experiments, possesses several good qualities, which recommend it to particular notice; it is hardy, early, and more productive than many others which affect similar soils and situations. Its growth after being cropped is tolerably rapid, although it does not attain to a great length if left growing; like the *poa pratensis* it sends forth flower-stalks but once in a season, and it appears well calculated for permanent pasture on rich light soils.

5131. The annual meadow grass (*Poa annua*, c), is the most common of all grasses, and the least absolute in its habits. It is almost the only grass that will grow in towns and near works where the smoke of coal abounds. Though an annual grass, it is found in most meadows and pastures perpetually flowering, and affording an early sweet herbage, relished by all stock, and of as great importance to birds as wheat is to man. It hardly requires to be sown, as it springs up every where of itself. However, it may not be amiss to sow a few pounds of it per acre wherever perpetual pasture (not hay) is the object.

5132. The fine bent grass (*Agrostis vulgaris*, d), is one of the most common grasses, and according to the Woburn experiments, one of the earliest. The *A. palustris* is nearly as early in producing its foliage, though both flower late, and neither are very prolific either in bulk or nutritive matter.

5133. The narrow-leaved meadow grass (*Poa angustifolia*, e), though it flowers exp, yet is remarkable for the early growth of the leaves. According to the Woburn experiments the leaves attain to the length of more than twelve inches before the middle of April, and are soft and succulent; in May, however, when the flower-stalks make their appearance, it is subject to the disease termed rust, which affects the whole plant; the consequence of which is manifest in the great deficiency of produce in the crop at the time the seed is ripe, being one half less than at the time of the flowering of the

grass. Though this disease begins in the straws, the leaves suffer most from its effects, being at the time the seed is ripe completely dried up: the straws, therefore, constitute the principal part of the crop for mowing, and they contain more nutritive matter in proportion than the leaves. This grass is evidently most valuable for permanent pasture, for which, in consequence of its superior, rapid, and early growth, and the disease beginning at the straws, nature seems to have designed it. The grasses which approach nearest to this in respect of early produce of leaves, are the *poa fertilis*, *dactylis glomerata*, *phleum pratense*, *alopeurus pratensis*, *avena elatior*, and *bromus littoreus*, all grasses of a coarser kind.

5134. *The best natural pastures of England*, examined carefully during various periods of the season, were found by Sinclair, of Woburn, to consist of the following plants:—

<i>Alopecurus pratensis.</i>	<i>Anthoxanthum odoratum.</i>	<i>Bromus arvensis</i> (frequent.)
<i>Dactylis glomerata.</i>	<i>Holcus avenaceus.</i>	<i>Poa annua.</i>
<i>Festuca pratensis.</i>	<i>Vicia sepium.</i>	<i>Avena pratensis.</i>
<i>Phleum pratense.</i>	<i>Lolium perenne.</i>	

These afford the principal grass in the spring, and also a great part of the summer produce.

<i>Avena flavescens.</i>	<i>Poa trivialis.</i>	<i>Trifolium repens.</i>
<i>Hordeum pratense.</i>	<i>Poa pratensis.</i>	<i>Lathyrus pratensis.</i>
<i>Cynosurus cristatus.</i>	<i>Holcus lanatus.</i>	<i>Festuca duriuscula.</i>
<i>Festuca duriuscula.</i>	<i>Trifolium pratense.</i>	

These yield produce principally in summer and autumn.

<i>Achillea millefolium.</i>	<i>Agrostis stolonifera</i> and <i>palustris.</i>	<i>Triticum repens.</i>
------------------------------	---	-------------------------

These vegetate with most vigor in autumn.

<i>Ranunculus acris.</i>	<i>Plantago lanceolata.</i>	<i>Rumex acetosa.</i>
--------------------------	-----------------------------	-----------------------

The first and last of these plants are to be considered as injurious; and the other is of little value as herbage. (*Hort. Gram. Wob. 2d edit. 133.*)

5135. *The above mixture* sown at the rate of four or five bushels to the acre, on well prepared soil without corn or other crop of any kind, could hardly fail of producing excellent pasture the following year, and for an endless period. The best time for sowing is July or August, as spring sown seeds are apt to suffer with the droughts of June and July. Fifteen of the above sorts are to be had from the seed shops; and all of them may be gathered from natural pastures, or bespoke from collectors. Sinclair, of Woburn, having entered into the seed and nursery business, and having expressed his intention to devote his particular attention to supplying the public with grass and other agricultural seeds, will probably render such seeds more common in commerce. (*Advt. by Cormack, Son and Sinclair.*)

5136. *Of late pasture grasses* the different species of cat's-tail (*Phleum*), and bent-grass (*Agrostis*), are the chief, and especially the Timothy and florin-grass. The grasses, Sir H. Davy observes, that propagate themselves by stolones, the different species of agrostis, supply pasture throughout the year; and the concrete sap, stored up in their joints, renders them a good food even in winter.

5137. *Of pasture grasses for inferior soils* one of the most durable is the dog's-tail grass (*Cynosurus cristatus*, fig. 584 a). This is a very common grass on dry, clayey, or firm

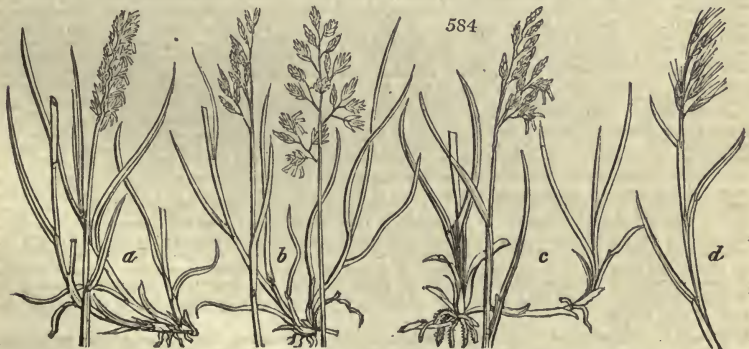

surfaces. It is one of the best grasses for parks, being highly relished by the South Down sheep and deer.

5138. *The hard fescue grass* (*Festuca duriuscula*, b), is one of the best of the dwarf sorts of grasses. It is grateful to all kinds of cattle; hares are very fond of it; at Woburn they crop it close to the roots, and neglect the *festuca ovina*, and *festuca rubra*, which grow contiguous to it. It is present in most good meadows and pastures, and with *F. ovina* is the best for lawns.

5139. *The festuca glabra* (c), and *hordiformis* (d), greatly resemble the hard fescue, and may be considered as equally desirable as pasture and lawn grasses.

5140. *The yellow oat grass* (*Avena flavescens*), is very generally cultivated, and appears, from the Woburn experiments, to be a very valuable grass for pasture on a clayey soil.

5141. *Of pasture grasses for inferior soils and upland situations, one of the principal is the festuca ovina, or sheep's fescue grass (fig. 585 a)* This grass is peculiarly adapted for hilly sheep pastures. It is a very dwarf grass, but relished by all kinds of cattle. According to Sinclair's experience, "on dry soils that are incapable of producing the larger sorts, this should form the principal crop, or rather the whole; for it is seldom or ever, in its natural state, found intimately mixed with others, but by itself.



5142. *The Poa alpina (b), Alopecurus alpinus, and Aira cæspitosa (c), Briza media (d), and minima, and Agrostis humilis and vulgaris, are all dwarf mountain grasses, well adapted for hilly parks or lawns.*

5143. *On the culture of these grasses it is unnecessary to enlarge, as it must obviously be the same as that of rye-grass or any of the others. The chief difficulty is to get the seed in sufficient quantity, for which a good mode is to contract with a seedsman for the quantity wanted a year before hand. With all the pasture grasses, excepting the last class, we should recommend at least half the seed used to be that of the perennial rye-grass; and we think it should also form a considerable part of the seeds used in laying down all meadows, excepting those for the aquatic or stoloniferous grasses. These, if they thrive, are sure to choke and destroy it, and therefore neither rye-grass, or any other grass, should ever be sown with Timothy grass or forin.*

5144. *The formation of grassy surfaces by distributing pieces of turf over them, has long been practised in gardening, in levelling down raised, or filling up hollow fences, and in other cases of partially altering a grassy surface; it is said to have been first used in agriculture by Whitworth, of Acre-house, Lincolnshire, and in 1812 it was brought forward on a large scale by John Blomfield, of Warham, in Norfolk, a tenant of Coke's. Blomfield planted eleven acres in this way. An account of the process, which is styled transplanting turf, or inoculating land with grass, has been published by Francis Bleakie, Coke's steward. (On the Conversion of Arable Land into Pasture, 12mo. 1817.)*

5145. *An abstract of the process of transplanting turf, and an opinion on it, are thus given in The Code of Agriculture. A piece of good, clean, sweet old turf, which ought principally to consist of fibrous rooted plants, is cut into small pieces of about three inches square, and placed about six inches apart on the surface of ground pressed for that purpose. In this way one acre of turf will plant nine acres of arable land. The pieces of flag should be carefully placed with the grass side uppermost, and the plants pressed well into the ground. No more turf should be cut, carried, and spread in any one day than is likely to be planted before night. If the transplanted turf is found deficient in any particular species of favorite plants, as white clover, permanent red clover, &c. the seeds of those plants should be sown upon the young pasture in April. When the ground is in proper temper (between wet and dry) the pasture should be frequently well pressed down by heavy rollers, which will cause the plants to extend themselves along the ground rather than rise into tufts, which otherwise they would be apt to do. No stock should be permitted to feed upon the transplanted pasture in the first spring or summer, nor until the grasses have perfected and shed their seeds. Indeed the pasturing should be very moderate until the mother grass-plants and their young progeny have united and formed a compact turf. The expense of this operation is about 2l. 10s. per statute acre; without making any allowance for the charges incurred by summer following the arable land on which the turf has been transplanted; nor for the year's rent, poor's rates, and taxes for that year; nor for restoring the land whence the turf plants were taken, to its previous state. This plan seems to be well calculated to promote the improvement of light soils, not naturally of a grassy nature, for the grasses and their roots being once formed on a rich soil, will probably thrive afterwards even on a poor one, as they will derive a considerable proportion of their nourishment from the atmosphere. For light and gravelly soils, therefore, where permanent pasture is desirable, the plan cannot be too strongly recommended; and if it were found to answer on peat, after the surface was pared for the reception of the plants, and burnt to promote their growth, it would be a most valuable acquisition to sheep farmers in many districts of the country. Thus far Sir John Sinclair, but from facts related by Sinclair of Woburn, it appears to be a plan of little or no merit, only brought into notice by its novelty. (H. G. Wob. 2d edit. 420, 421.)*

SECT. III. *General View of the Produce, Uses, Character, and Value of the principal British Grasses, according to the result of John Duke of Bedford's Experiments at Woburn.*

5146. *In all permanent pastures, Sir H. Davy observes, nature has provided a mixture of various grasses, the produce of which differs at different seasons. Where pastures are to be made artificially, such a mixture ought to be imitated; and, perhaps, pastures superior to the natural ones may be made by selecting due proportions of those species of grasses fitted for the soil, which afford respectively the greatest quantities of spring, summer, latermath, and winter produce; a reference to the results of the Woburn experiments, he adds, will show that such a plan of cultivation is very practicable.*

5147. *The manner in which these experiments were conducted is thus described. "Spots of ground, each containing four square feet, in the garden at Woburn Abbey, were enclosed by boards in such a manner that there was no lateral communication between the earth included by the boards, and that of the garden. The soil was removed in these enclosures, and new soils supplied; or mixtures of soils were made*

in them, to furnish as far as possible to the different grasses those soils which seem most favorable to their growth; a few varieties being adopted for the purpose of ascertaining the effect of different soils on the same plant. The grasses were either planted or sown, and their produce cut and collected, and dried at the proper seasons, in summer and autumn, by Sinclair, his Grace's gardener. For the purpose of determining, as far as possible, the nutritive powers of the different species, equal weights of the dry grasses or vegetable substances were acted upon by hot water till all their soluble parts were dissolved; the solution was then evaporated to dryness by a gentle heat in a proper stove, and the matter obtained carefully weighed. This part of the process was likewise conducted with much address and intelligence by Sinclair, by whom all the following details and calculations are furnished. The dry extracts supposed to contain the nutritive matter of the grasses, were sent to me for chemical examination. The composition of some of them is stated minutely; but it will be found from the general conclusions, that the mode of determining the nutritive power of the grasses, by the quantity of matter they contain soluble in water, is sufficiently accurate for all the purposes of agricultural investigation." (*Agr. Chem. app.*)

5148. *The leading results of these experiments* we have endeavored to present in a tabular view; farther details will be found in the paragraphs (antecedent and posterior) referred to in the first column. On the other columns of the table, it may be observed, that the height is given more by a guess than measurement, and after the appearance of the plants in a state of nature or medium soils. It is to be regretted, that the height of the plants at Woburn, were not included in the published details. The time of flowering is given, as it took place at Woburn, on which it is observed, that "to decide positively the exact period or season, when a grass always comes into flower, and perfects its seed, will be found impracticable; for a variety of circumstances interfere. Each species seems to possess a peculiar life in which various periods may be distinctly marked, according to the varieties of its age, of the seasons, soils, exposures, and mode of culture."

5149. *The soils*, as denominated in the column devoted to them, are thus described. 1st, By loam, is meant any of the earths combined with decayed animal, or vegetable matter. 2nd, Clayey loam, when the greatest proportion is clay. 3d, Sandy loam, when the greatest proportion is sand. 4th, Brown loam, when the greatest proportion consists of decayed vegetable matter. 5th, Rich black loam, when sand, clay, animal, and vegetable matters are combined in unequal proportions, the clay greatly divided, being in the least proportion, and the sand and vegetable matter in the greatest. The terms light sandy soil, light brown loam, &c. are varieties of the above, as expressed. The abbreviations of the names of books and native soils, will be found in common with all the other abbreviations used in this work explained in the General Index.

5150. *On the nutritive products*, Sir H. Davy has the following valuable remarks, some of which on the operations in the animal economy of the different substances, composing the nutritive matter, the agriculturist will find useful, as applied to the tables before given (4598. 4738, &c.) of the nutritive products of the corns, legumes, and roots. The only substances which Sir H. Davy detected in the soluble matters procured from the grasses, are mucilage, sugar, bitter extract, a substance analogous to albumen, and different saline matters. Some of the products from the aftermath crops, gave feeble indications of the tanning principle. In the experiments made on the quantity of nutritive matter in the grasses, cut at the time the seed was ripe, the seeds were always separated: and the calculations of nutritive matter made from grass and not hay.

5151. *The order in which these substances are nutritive*, is thus given: "The albumen, sugar, and mucilage, probably when cattle feed on grass or hay, are for the most part retained in the body of the animal; and the bitter principle, extract, saline matter, and tanning, when any exist, probably for the most part are voided in the excrement, with the woody fibre. The extractive matter obtained by boiling the fresh dung of cows, is extremely similar in chemical characters to that existing in the soluble products from the grasses. And some extract, obtained by Sinclair from the dung of sheep and of deer, which had been feeding upon the *lolium perenne*, *dactylis glomerata*, and *trifolium repens*, had qualities so analogous to those of the extractive matters obtained from the leaves of the grasses, that they might be mistaken for each other. The extract of the dung, after being kept for some weeks, had still the odor of hay. Suspecting that some undigested grass might have remained in the dung, which might have furnished mucilage and sugar, as well as bitter extract, I examined the soluble matter very carefully for these substances. It did not yield an atom of sugar, and scarcely a sensible quantity of mucilage." Sinclair, in comparing the quantities of soluble matter afforded by the mixed leaves of the *lolium perenne*, *dactylis glomerata*, and *trifolium repens*, and that obtained from the dung of cattle fed upon them, found their relative proportions, as 50 to 13.

5152. *From these facts it appears probable* that the bitter extract, though soluble in a large quantity of water, is very little nutritive; but probably it serves the purpose of preventing, to a certain extent, the fermentation of the other vegetable matters, or in modifying or assisting the function of digestion, and may thus be of considerable use in forming a constituent part of the food of animals. A small quantity of bitter extract and saline matter is probably all that is needed, and beyond this quantity the soluble matters must be more nutritive in proportion as they contain more albumen, sugar, and mucilage; and less nutritive in proportion as they contain other substances.

5153. *In comparing the composition of the soluble products afforded by different crops* from the same grass, Sir H. Davy found, in all the trials, the largest quantity of truly nutritive matter, in the crop cut when the seed was ripe, and least bitter extract and saline matter; most extract and saline matter in the autumnal crop; and most saccharine matter in proportion to the other ingredients, in the crop cut at the time of flowering.

5154. *The greater proportion of leaves in the spring*, and particularly in the late autumnal crop, accounts for the difference in the quantity of extract; and the inferiority of the comparative quantity of sugar in the summer crop, probably depends upon the agency of light, which tends always in plants to convert saccharine matter into mucilage or starch. Amongst the soluble matters afforded by the different grasses, that of the *elymus arenarius* (fig. 543 a.) was remarkable for the quantity of saccharine matter it contained, amounting to more than one-third of its weight. The soluble matters from the different species of *festuca*, in general afforded more bitter extractive matter, than those from the different species of *poa*. The nutritive matter from the seed crop of the *poa compressa* was almost pure mucilage. The soluble matter of the seed crop of *phleum pratense*, or meadow cat's-tail, afforded more sugar than any of the *poa* or *festuca* species. The soluble parts of the seed crop of the *holcus mollis*, and *holcus lanatus*, contained no bitter extract, and consisted entirely of mucilage and sugar. Those of the *holcus odoratus* afforded bitter extract, and a peculiar substance having an acrid taste, more soluble in alcohol than in water. All the soluble extracts of those grasses, that are most liked by cattle, have either a saline or subacid taste; that of the *holcus lanatus* is similar in taste to gum arabic. Probably the *holcus lanatus*, which is so common a grass in meadows, might be made palatable to cattle by being sprinkled over with salt.

5155. *No difference was found in the nutritive produce of the crops of the different grasses cut at the same season*, which would render it possible to establish a scale of their nutritive powers; but probably the soluble matters of the aftermath crop are always from one-sixth to one-third less nutritive, than those from the flower or seed crop. In the aftermath the extractive and saline matters are certainly usually in excess; but the aftermath hay mixed with summer hay, particularly that in which the fox-tail and soft grasses are abundant, would produce an excellent food.

5156.

Table of the Grasses experimented on at

References to further Details and Remarks.	Systematic Name and Authority.	English Name and Native Country.	Where figured or described.	Natural Duration.	Height in a wild state in inches.	Time of flowering at Woburn.	Time of ripening the Seed at Woburn.	Soil at Woburn.	Natural Soil and Situation as in Smith's Flora Brit.
5157.	<i>Anthoxanthum odoratum</i> , L.	Sweet-scented vernal grass, Brit.	E. B. 647	Peren.	12	April 29.	June 21.	Brown sandy loam	Meadows!
5158	<i>Holcus odoratus</i> , Host.	Sweet-scented soft grass, Ger.	Host. N.A.	Peren.	14	April 29.	June 25.	Rich sandy loam	Woods, moist mea.
5159.	<i>Cynosurus ceruleus</i> , E. B.	Blue moor grass, Brit.	E. B. 1613	-	20	April 30.	June 20.	Light sandy soil	Pastures
5142.	<i>Alopecurus alpinus</i> , E. B.	Alpine foxtail grass, Scot.	E. B. 1126	Peren.	6	May 20.	June 24.	Sandy loam	Scotch mountains
	<i>Poa alpina</i> , E. B.	Alpine meadow grass, Scot.	E. B. 1003	Peren.	6	May 30.	June 30.	Light sandy loam	Scotch Alps
5109.	<i>Alopecurus pratensis</i> , E. B.	Meadow foxtail grass, Brit.	E. B. 848	Peren.	24	May 30.	June 24.	Clayey loam Sandy loam	Meadows
5111.	<i>Poa pratensis</i> , E. B.	Smooth-stalked meadow grass, Brit.	E. B. 1075	Peren.	18	May 30.	July 14.	Bog earth and clay	Mead. & pastures
5161.	<i>Poa cerulea</i> , var. <i>pratensis</i> , E. B.	Short bluish meadow grass, Brit.	E. B. 1004	Peren.	14	May 30.	July 14.	Bog earth and clay	Meadows
5160.	<i>Avena pubescens</i> , E. B.	Downy oat grass, Brit.	-	Peren.	18	June 13.	July 8.	Rich sandy soil	Chalky pastures
5162.	<i>Festuca horridiformis</i> or <i>F. horridiformis</i> , H.C.	Barley-like fescue grass, Hungary	-	Peren.	18	June 13.	July 10.	Manured sandy soil	Corn fields
5113.	<i>Poa trivialis</i> , E. B.	Roughish mead. gr. Brit.	E. B. 1072	-	20	June 15.	July 10.	Man. light br. loam	Meadows
5165.	<i>Festuca glauca</i> , Curtis	Glaucaus fescue gr. Brit.	-	Peren.	12	June 15.	July 10.	Brown loam	Chalky pastures
5164.	<i>Festuca glabra</i> , With.	Smooth fescue gr. Scot.	-	Peren.	9	June 16.	July 10.	Clayey loam	Mountains
5165.	<i>Festuca rubra</i> , With.	Purple fescue grass, Brit.	-	Peren.	12	June 20.	July 10.	Light sandy soil	Mead. & pastures
5166.	<i>Briza media</i> , E. B.	Common quaking gr. Brit.	E. B. 585.	Peren.	6	June 24.	July 10.	Rich brown loam	Pastures
	<i>Dactylis glomerata</i> , E. B.	Rough-head, cock's-foot grass, Brit.	E. B. 340.	Peren.	16	June 24.	July 10.	Rich brown loam	Pastures
5100.	<i>Bromus tectorum</i> , Host.	Notting pencilled brome G. A.	E. B. 355.	Peren.	24	June 24.	July 14.	Rich sandy loam	Soft moist soils
	<i>Bromus cambrica</i> , Huds.	Cambridge fescue gr. Brit.	-	Annual	12	June 24.	July 16.	Light sandy soil	Hedges
5167.	<i>Bromus diandrus</i> , E. B.	Upright brome grass, Brit.	E. B. 1006	Annual	18	June 28.	July 16.	Rich brown loam	Dry pastures
5168.	<i>Poa angustifolia</i> , With.	Narrow-lea. mead. gr. Brit.	-	Peren.	24	June 28.	July 16.	Brown loam	Corn fields
5169.	<i>Avena elatior</i> , Curtis	Tall oat grass	E. B. 813	Peren.	50	June 28.	July 16.	-	Arable lands
5170.	<i>Holcus avenaceus</i> , Will.	Knot grass, Brit.	-	-	-	-	-	-	-
	<i>Poa elatior</i> , Curtis	Tall meadow grass, Scot.	-	Peren.	30	June 28.	July 16.	Rich clay loam	Meadows
5171.	<i>Avena elatior</i> , var.	Hard fescue grass, Brit.	E. B. 470	Peren.	12	July 1.	July 20.	Light sandy loam	Pastures
5172.	<i>Bromus erectus</i> , E. B.	Upright brome gr. Brit.	E. B. 471	Peren.	36	July 1.	July 20.	Rich sandy soil	Chalky pastures
	<i>Milium efusum</i> , E. B.	Common millet grass, Brit.	E. B. 1106	Peren.	40	July 1.	July 20.	Light sandy soil	Woods
5173.	<i>Festuca pratensis</i> , E. B.	Meadow fescue grass, Brit.	E. B. 1592	Peren.	50	July 1.	July 20.	Bog soil & coal ashes	Meadows
5174.	<i>Lolium perenne</i> , E. B.	Perennial rye grass, Brit.	E. B. 315	Peren.	24	July 1.	July 20.	Rich brown loam	Loamy pastures
5095.	<i>Poa maritima</i> , E. B.	Sea meadow grass, Brit.	E. B. 1140	Peren.	12	-	-	Light brown loam	Salt marshes
5177.	<i>Festuca lolifera</i> , E. B.	Spiked fescue grass, Brit.	E. B. 1821	Peren.	36	July 1.	July 28.	Rich brown loam	Moist pastures
5178.	<i>Alopecurus cristatus</i> , E. B.	Crested dog's-tail gr. Brit.	E. B. 648	Peren.	40	July 6.	July 28.	Manured br. loam	Pastures
5175.	<i>Avena pratensis</i> , E. B.	Meadow oat grass, Brit.	E. B. 1204	Peren.	24	July 6.	July 20.	Rich sandy loam	Pastures
5176.	<i>Bromus multiflorus</i> , E. B.	Many fl. g. brome gr. Brit.	E. B. 1884	Annual	24	July 6.	July 28.	Clayey loam	Poor past., hedges
5179.	<i>Festuca myurus</i> , E. B.	Wall fescue grass, Brit.	E. B. 1412	Annual	9	July 6.	July 28.	Light sandy soil	Walls
	<i>Aira flexuosa</i> , E. B.	Waved mount. hair gr. Brit.	E. B. 1519	Peren.	9	July 6.	July 28.	Heath soil	Dry soils & heaths
	<i>Hordeum bulbosum</i> , Hort. K.	Bulbous barley gr. Italy	-	Peren.	24	July 10.	July 28.	Man. clayey loam	Loamy pastures
5180.	<i>Festuca calamaria</i> , E. B.	Red-like fescue gr. Brit.	E. B. 1005	Peren.	40	July 10.	July 28.	Clayey loam	Hedges
5181.	<i>Bromus litoreus</i> , Host.	Seaside brome grass, Ger.	-	Peren.	20	July 12.	Aug. 6.	Clayey loam	Sea shores
	<i>Festuca elatior</i> , E. B.	Tall fescue grass, Brit.	E. B. 1593	Peren.	36	July 12.	Aug. 6.	Black rich loam	Meadows
5107.	<i>Festuca fluviatilis</i> , E. B.	Floating fescue grass, Brit.	E. B. 1520	Peren.	18	July 14.	Aug. 12.	Str. tenacious clay	Ponds
5117.	<i>Holcus lanatus</i> , W.	Meadow soft grass, Brit.	E. B. 1169	Peren.	24	July 14.	Aug. 26.	Strong clayey loam	Moist meadows
5102.	<i>Festuca dumetorum</i> , W.	Pubescent fescue gr. Brit.	H. D. 700	Peren.	12	July 14.	July 20.	Black sandy loam	Woods
5183.	<i>Poa fertilis</i> , Host. G. A.	Fertile mead. grass, Ger.	-	Peren.	20	July 14.	July 28.	Clayey loam	Meadows
5184.	<i>Arundo colostrata</i> , Hort. K.	Strip-lea. reed gr. Brit.	E. B. 402	Peren.	40	July 16.	July 28.	Black sandy loam	Moist loams
5119.	<i>Pheleum nodosum</i> , With.	Brown-stalked cat's tail grass, Brit.	-	Peren.	18	July 16.	July 20.	Clayey loam	Dry pastures
5116.	<i>Pheleum pratense</i> , With.	Meadow cat's tail gr. Brit.	-	Peren.	21	July 16.	July 30.	Clayey loam	Mead. & pastures
5185.	<i>Hordeum pratense</i> , E. B.	Meadow barley grass, Brit.	E. B. 409	Peren.	24	July 20.	Aug. 8.	Man. brown loam	Meadows
	<i>Poa compressa</i> , E. B.	Flat-stalked mead. gr. Brit.	E. B. 365	Annual	12	July 20.	Aug. 8.	Man. gravelly soil	Walls
5118.	<i>Poa aquatica</i> , E. B.	Red meadow grass, Brit.	E. B. 1515	Peren.	72	July 20.	Aug. 8.	Str. tenacious clay	Ditches
	<i>Aira aquatica</i> , E. B.	Water hair grass, Brit.	E. B. 1557	Peren.	9	-	-	Water	-
5142.	<i>Avena caspitosa</i> , E. B.	Yellow hair grass, Brit.	E. B. 1453	Peren.	9	July 24.	Aug. 10.	Str. tenacious clay	Clayey pastures
5186.	<i>Avena flavescens</i> , E. B.	Turfy oat grass, Brit.	E. B. 932	Peren.	18	July 24.	Aug. 15.	Clayey loam	Pastures
5187.	<i>Bromus sterilis</i> , E. B.	Barren brome grass, Brit.	E. B. 1030	Annual	24	July 24.	Aug. 20.	Sandy soil	Rubbish
5188.	<i>Holcus mollis</i> , Curtis	Creeping soft grass, Brit.	-	Peren.	30	July 24.	Aug. 20.	Sandy soil	Sandy pastures
5189.	<i>Poa fertilis</i> , var. B. Host. G. A.	Fertile meadow gr. Ger.	-	Peren.	24	-	-	Brown sandy loam	Meadows
	<i>Agrostis vulgaris</i> , E. B.	Fine bent grass, Brit.	E. B. 1671	Peren.	18	July 24.	Aug. 20.	Sandy soil	Mead. & pastures
5191.	<i>Agrostis palustris</i> , E. B.	Marsh bent grass, Brit.	E. B. 1189	Peren.	20	July 28.	Aug. 28.	Bog earth	Marshy places
	<i>Panicum dactyloides</i> , E. B.	Creeping panic grass, Brit.	E. B. 850	Peren.	24	July 28.	Aug. 28.	Man. sandy loam	Arable lands
	<i>Agrostis stolonifera</i> , E. B.	Flora of Dr. Richardson.	E. B. 1532	Peren.	24	July 28.	Aug. 28.	Bog soil	Moist places
5119.	<i>Agrostis stolonif</i> var. <i>angustif.</i>	Narrow-leaved, creeping bent, Brit.	-	Peren.	24	July 28.	Aug. 28.	Bog soil	Moist places
5120.	<i>Festuca pennata</i>	Spiked fescue, Brit.	E. B. 730	Peren.	24	July 28.	Aug. 30.	Man. light san. soil	Meadows
	<i>Agrostis canina</i> , E. B.	Gr. or couch gr. Brit.	E. B. 1836	Peren.	9	July 28.	Aug. 30.	Brown sandy loam	Clayey pastures
	<i>Agrostis stricta</i> , Curtis	Upright bent grass, Brit.	-	Peren.	9	July 28.	Aug. 30.	Bog soil	Clayey pastures
5191.	<i>Agrostis arvensis</i>	Snowy bent grass, Brit.	-	Peren.	9	Aug. 10.	Aug. 30.	Sandy soil	Clayey pastures
	<i>Agrostis fascicularis</i> , var. <i>canina</i> , Curtis	Tufted-lea. bent gr. Brit.	-	Peren.	9	Aug. 10.	Aug. 30.	Light sandy soil	Clayey pastures
	<i>Panicum viride</i> , Curtis	Green panic grass, Brit.	E. B. 875	Annual	36	Aug. 2.	Aug. 15.	Light sandy soil	Sandy pastures
	<i>Agrostis lobata</i> , Curtis	Lobed bent grass, Brit.	-	Peren.	20	Aug. 6.	Aug. 20.	Sandy soil	Sandy pastures
5120.	<i>Agrostis repens</i> , With.	Black or creeping rooted bent, bl. couch, Brit.	-	Peren.	26	Aug. 8.	Aug. 25.	Clayey loam	Arable lands
	<i>Triticum repens</i> , E. B.	Creeping rooted wheat gr. or couch gr. Brit.	E. B. 848	Peren.	30	Aug. 10.	Aug. 30.	Light clayey loam	Arable lands
	<i>Alopecurus agrestis</i>	Slender foxtail grass, Brit.	E. B. 1172	Annual	8	Aug. 10.	Sept. 8.	Light sandy loam	Road sides
	<i>Bromus asper</i> , E. B.	Hairy stalked br. gr. Brit.	E. B. 1510	Annual	48	Aug. 10.	Sept. 10.	Light sandy soil	Moist san. places
	<i>A. mexicana</i> , Hort. K.	Mexican bent gr. S. Amer.	E. B. 1356	Peren.	24	Aug. 15.	Sept. 25.	Black sandy soil	Rich pastures
	<i>Stipa pennata</i> , E. B.	Long awned fca. gr. Brit.	E. B. 909	Peren.	20	Aug. 15.	Sept. 25.	Heath soil	Peat bogs
	<i>Melica cerulea</i> , Curtis	Purple melic grass, Brit.	-	Peren.	20	Aug. 29.	Sept. 30.	Light sandy soil	Sandy pastures
	<i>Phalaris canariensis</i> , E. B.	Com. Canary grass, Brit.	E. B. 750	Annual	26	Aug. 30.	Sept. 30.	Clayey loam	Cultivated fields
	<i>Dactylis cynosuroides</i> , Lili.	Americ. cock's foot gr. N.A.	-	Peren.	21	Aug. 30.	Oct. 20.	Clayey loam	Loamy pastures





5157. *Anthozanthum odoratum*, E. B. — The proportional value which the grass at the time of flowering bears to that at the time the seed is ripe, is as 4 to 13. The proportional value which the grass of the lattermath bears to that at the time the seed is ripe, is nearly as 9 to 13.
5158. *Holcus odoratus*, Hors. G. A. — The proportional value which the grass at the time of flowering bears to that at the time the seed is ripe, is as 17 to 21. The grass of the lattermath crop, and of the crop at the time of flowering, taking the whole quantity, and their relative proportions of nutritive matter, are in value nearly as 6 to 10: the value of the grass at the time the seed is ripe, exceeds that of the latter-math, in proportion as 21 to 17. Though this is one of the earliest of the flowering grasses, it is tender, and the produce in the spring is inconsiderable. If, however, the quantity of nutritive matter which it affords, be compared with that of any of those species which flower nearly at the same time, it will be found greatly superior. It sends forth but a small number of flower-stalks, which are of a slender structure compared to the size of the leaves. This will account in a great measure for the equal quantities of nutritive matter afforded by the grass at the time of flowering, and the lattermath.
5159. *Cynosurus cæruleus*, E. B. — The produce of this grass is greater than its appearance would denote; the leaves seldom attain to more than four or five inches in length, and the flower-stalks seldom arise to more. Its growth is not rapid after being cropped, nor does it seem to withstand the effects of frost, which if it happen to be severe and early in the spring, checks it so much as to prevent it from flowering for that season; otherwise the quantity of nutritive matter which the grass affords (for the straws are very inconsiderable), would rank it as a valuable grass for permanent pasture.
5160. *Avena pubescens*, E. B. — The proportional value which the grass at the time of flowering bears to that at the time the seed is ripe, is as 6 to 8. The proportional value which the grass at the time of flowering bears to that of the lattermath, is as 6 to 8. The grass of the seed-crop, and that of the lattermath, are of equal value. The downy hairs which cover the surface of the leaves of this grass, when growing on poor light soils, almost entirely disappear when it is cultivated on a richer soil.
5161. *Poa cærulea*, var. *pratensis*, E. B. — If the produce of this variety be compared with that of *poa pratensis*, it will be found less; nor does it seem to possess any superior excellence. The superior nutritive power does not make up for the deficiency of produce by 80 lbs. of nutritive matter per acre.
5162. *Festuca hordiformis*, H. Cant. — This is rather an early grass, though later than any of the preceding species: its foliage is very fine, resembling the *F. duriuscula*, to which it seems nearly allied, differing only in the length of the awns, and the glaucous color of the whole plant. The considerable produce it affords, and the nutritive powers it appears to possess, joined to its early growth, are qualities which strongly recommend it to further trial.
5163. *Festuca glauca*, Curtis. — The proportional value by which the grass at the time of flowering exceeds that at the time the seed is ripe, is as 6 to 12. The proportional difference in the value of the flowering and seed crops of this grass is directly the reverse of that of the preceding species, and affords another strong proof of the value of the straws in grass which is intended for hay. The straws at the time of flowering are of a very succulent nature; but from that period till the seed be perfected, they gradually become dry and wiry. Nor does the root-leaves sensibly increase in number or in size, but a total suspension of increase appears in every part of the plant, the roots and seed vessels excepted. The straws of the *poa trivialis* are, on the contrary, at the time of flowering, weak and tender; but as they advance towards the period of ripening the seed, they become firm and succulent; after that period, however, they rapidly dry up, and appear little better than a mere dead substance.
5164. *Festuca glabra*, Wither. B. — The proportional value which the grass at the time the seed is ripe bears to that of the crop at the time of flowering is as 5 to 8. The proportional value which the grass of the lattermath bears to that of the crop at the time of flowering, is as 2 to 8, and to that of the crop, at the time the seed is ripe, is as 2 to 5. The general appearance of this grass is very similar to that of the *festuca duriuscula*: it is, however, specifically different, and inferior in many respects, which will be manifest on comparing their several produce with each other; but if it be compared with some others, now under general cultivation, the result is much in its favor, the soil which it affects being duly attended to.
5165. *Festuca rubra*, Wither. B. — The proportional value which the grass at the time of flowering bears to that at the time the seed is ripe, is as 6 to 8. This species is smaller in every respect than the preceding. The leaves are seldom more than from three to four inches in length; it affects a soil similar to that favorable to the growth of the *festuca ovina*, for which it would be a profitable substitute, as will clearly appear on a comparison of their produce with each other. The proportional value which the grass of the lattermath bears to that at the time the seed is ripe is as 6 to 8, and is of equal value with the grass at the time of flowering.
5166. *Festuca ovina*, E. B. — The dry weight of this species was not ascertained, because the smallness of the produce renders it entirely unfit for hay.
5167. *Festuca cambrica*, Hud. — This species is nearly allied to the *festuca ovina*, from which it differs little, except that it is larger in every respect. The produce, and the nutritive matter which it affords, will be found superior to those given by the *F. ovina*, if they are brought into comparison.
5168. *Bromus dianthus*, Curt. Lond. — This species, like the *festuca cambrica*, is strictly annual; the above is therefore the produce for one year, which, if compared with that of the least productive of the perennial grasses, will be found inferior, and it must consequently be regarded as unworthy of culture.
5169. *Poa angustifolia*, With. 2. — In the early growth of the leaves of this species of *Poa*, there is a striking proof that early flowering in grasses is not always connected with the most abundant early produce of leaves. In this respect, all the species which have already come under examination are greatly inferior to that now spoken of. The culms are most valuable for the manufacture of the finest straw plait.
5170. *Avena elatior*, Curt. — This grass sends forth flower-straws during the whole season; and the lattermath contains nearly an equal number with the flowering crop. It is subject to the rust, but the disease does not make its appearance till after the period of flowering; it affects the whole plant, and at the time the seed is ripe the leaves and straws are withered and dry. This accounts for the superior value of the lattermath over the seed crop, and points out the propriety of taking the crop when the grass is in flower.
5171. *Poa elatior*, Curt. — The botanical characters of this grass are almost the same as those of the *avena elatior*, differing in the want of the awns only. It has the essential character of the *holci*, (florets, male and hermaphrodite; calyx husks two-valved, with two florets); and since the *avena elatior* is now referred to that genus, this may with certainty be considered a variety of it.
5172. *Festuca duriuscula*, E. B. — The proportional value which the grass at the time the seed is ripe, bears to that at the time of flowering, is as 6 to 14 nearly. The proportional value which the grass of the lattermath bears to that at the time of flowering, is as 5 to 14, and to that at the time the seed is ripe 5 to 6. The above particulars will confirm the favorable opinion which was given of this grass when speaking of the *F. hordiformis*, and *F. glabra*. (5162. and 5164.) Its produce in the spring is not very great, but of the finest quality, and at the time of flowering is considerable. If it be compared with those affecting similar soils, such as *poa pratensis*, *festuca ovina*, &c, either considered as a grass for hay, or permanent pasture, it will be found of greater value.
5173. *Milium æfusum*. — This species in its natural state seems confined to woods as its place of growth; but the trial that is here mentioned, confirms the opinion that it will grow and thrive in open exposed situations. It is remarkable for the lightness of the produce in proportion to its bulk. It produces foliage early in the spring in considerable abundance; but its nutritive powers appear comparatively little.

5174. *Poa maritima*, E. B. — The proportional value which the grass of the lattermath bears to that at the time of flowering, is as 4 to 18.

5175. *Avena pratensis*, E. B. — The proportional value which the crop, at the time the seed is ripe, bears to that at the time of flowering, is as 4 to 9.

5176. *Bromus multiflorus*, E. B. — This species is annual, and no valuable properties have as yet been discovered in the seed. It is only noticed on account of its being frequently found in poor grass lands, and sometimes in meadows. It appears from the above particulars to possess nutritive powers equal to some of the best perennial kinds, if taken when in flower; but if left till the seed be ripe (which, from its early growth, is frequently the case), the crop is comparatively of no value, the leaves and straws being then completely dry.

5177. *Festuca loliacea*, Curt. Lond. — The proportional value which the grass at the time of flowering bears to that at the time the seed is ripe, is as 12 to 13; and the value of the lattermath stands in proportion to that of the crop at the time of flowering, as 5 to 12, and to that of the crop taken at the time the seed is ripe, as 5 to 13. This species of *Festuca* greatly resembles the rye-grass, in habit and place of growth; it has excellencies which make it greatly superior to that grass, for the purposes of either hay or permanent pasture. This species seems to improve in produce in proportion to its age, which is directly the reverse of the *lolium* perenne.

5178. *Poa cristata*, Host. G. A. — The produce of this species, and the nutritive matter that it affords, are equal to those of the *Festuca ovina* at the time the seed is ripe: they equally delight in dry soils. The greater bulk of grass in proportion to the weight, with the comparative coarseness of the foliage, render the *Poa cristata* inferior to the *Festuca ovina*.

5179. *Festuca myurus*, E. B. — This species is strictly annual; it is likewise subject to the rust; and, the produce being but little, it ranks as a very inferior grass.

5180. *Festuca calamaria*, E. B. — The proportional value which the grass at the time the seed is ripe, bears to that at the time of flowering, is as 12 to 18. This grass, as has already been remarked, produces a fine early foliage in the spring. The produce is very great, and its nutritive powers are considerable. It appears, from the above particulars, to be best adapted for hay. A very singular disease attacks, and sometimes nearly destroys the seed of this grass: the cause of this disease seems to be unknown; it is denominated *clavus* by some; it appears by the seed swelling to three times its usual size in length and thickness, and the want of the carcle. Dr. Willdenow describes two distinct species of it: first the simple *clavus*, which is mealy and of a dark color, without any smell or taste; secondly, the malignant *clavus*, which is violet blue, or blackish, and internally too has a blueish color, a fetid smell, and a sharp pungent taste. Bread, made from grain affected with this last species, is of a blueish color; and when eaten produces cramps and giddiness.

5181. *Bromus littoreus*, Host. G. A. — The proportional value which the grass at the time of flowering bears to that at the time the seed is ripe, is as 6 to 14. This species greatly resembles the preceding in habit and manner of growth; but is inferior to it in value, which is evident from the deficiency of its produce, and of the nutritive matter afforded by it. The whole plant is likewise coarser, and of greater bulk in proportion to its weight. The seed is affected with the same disease which destroys that of the former species.

5182. *Festuca stultans*, Curt. Lond. — The above produce was taken from grass that had occupied the ground for four years, during which time it had increased every year; it appears, therefore, contrary to what some have supposed, to be capable of being cultivated in perennial pastures.

5183. *Poa fertilis*, Host. G. A. — If the nutritive powers and produce of this species be compared with any other of the same family, or such as resemble it in habit and the soil which it affects, a superiority will be found, which ranks this as one of the most valuable grasses; next to the *Poa angustifolia*, it produces the greatest abundance of early foliage, of the best quality, which fully compensates for the comparative lateness of flowering.

5184. *Arundo colorata*, Hort. Kew. — The strong nutritive powers which this grass possesses, recommend it to the notice of occupiers of strong clayey lands which cannot be drained. Its produce is great, and the foliage will not be denominated coarse, if compared with those which afford a produce equal in quantity.

5185. *Hordeum pratense*, E. B. — The specific characters of this species are much the same as those of the *Poa fertilis*, differing in the compressed figure of the straws and creeping root only. If the produce was of magnitude, it would be one of the most valuable grasses; for it produces foliage early in the spring, and possesses strong nutritive powers.

5186. *Avena flavescens*, Curt. Lond. — The proportional value which the grass at the time the seed is ripe, bears to that at the time of flowering, is as 9 to 15. The proportional value which the grass of the lattermath bears to that at the time of flowering, is as 5 to 15; and to that at the time the seed is ripe, as 5 to 9.

5187. *Bromus sterilis*, E. B. — Sixty-four dr. of the flowers afford of nutritive matter 2.2 dr. The nutritive powers of the straws and leaves are, therefore, more than twice as great as those of the flowers. This species, being strictly annual, is of comparatively little value. The above particulars show that it has very considerable nutritive powers, more than its name would imply, if taken at the time of flowering; but if left till the seed be ripe, it is, like all other annuals, comparatively of no value.

5188. *Holcus mollis*. — Sixty-four dr. of the roots afford of nutritive matter 5.2 dr. The proportional value which the grass at the time the seed is ripe, bears to that at the time of flowering, is as 14 to 18. The above details prove this grass to have merits, which, if compared with those of other species, rank it with some of the best grasses. The small loss of weight which it sustains in drying might be expected from the nature of the substance of the grass; and the loss of weight at each period is equal. The grass affords the greatest quantity of nutritive matter when in flower, which makes it rank as one of those best adapted for hay.

5189. *Poa fertilis*, var.  $\beta$ . Host. G. A. — The proportional value which the grass at the time of flowering bears to that at the time the seed is ripe, is as 12 to 20. The proportional value which the grass of the lattermath bears to that at the time of flowering, is as 6 to 12; and to that at the time the seed is ripe, as 6 to 20.

5190. *Phleum nodosum*, Wither. — This grass is inferior in many respects to the *Phleum pratense*. It is sparingly found in meadows. From the number of bulbs which grow out of the straws a greater portion of nutritive matter might have been expected. This seems to prove that these bulbs do not form so valuable a part of the plant as the joints, which are so conspicuous in the *Phleum pratense*, the nutritive powers of which exceed those of the *P. nodosum*, as 8 to 28.

5191. *Agrostis vulgaris*, Wither. — This is one of the most common of the bents, and likewise the earliest; in these respects it is superior to all others of the same family, but inferior to several of them in produce, and the quantity of nutritive matter it affords. As the species of this family are generally rejected by the cultivator on account of the lateness of their flowering; and this circumstance, as has already been observed, does not always imply a proportional lateness of foliage, their comparative merits in this respect may be better seen, by bringing them into one view, as to the value of their early foliage.

	The apparent Difference of Time.	Their nutritive Powers.		The apparent Difference of Time.	Their nutritive Powers.
<i>Agrostis vulgaris</i>	- Middle of April	1.2 $\frac{1}{2}$	<i>Agrostis nivea</i>	- Three weeks later	- 2
<i>palustris</i>	- One week later	2.5	<i>littoralis</i>	- Ditto ditto	- 3
<i>stolonifera</i>	- Two ditto	3.2	<i>repens</i>	- Ditto ditto	- 5
<i>caudata</i>	- Ditto ditto	3.5	<i>medicana</i>	- Ditto ditto	- 2
<i>stricta</i>	- Ditto ditto	1.2	<i>fascicularis</i>	- Ditto ditto	- 2

5192. *Panicum sanguinale*, E. B. — This species is strictly annual; and from the results of this trial, its nutritive powers appear to be very inconsiderable.

5193. *The grasses which afford the best culms for straw plait* are, according to Sinclair, as follow :

*For heath or moor soil.* Festuca ovina, duriuscula and horridiformis, Nardus stricta.

*Dry soils.* Cynosurus cristatus, poa angustifolia, hordeum pratense, anthoxanthum odoratum, agrostis lobata, spicaveni, flavescens and vulgaris mutica, avena pubescens, festuca heterophylla.

*Moist soils.* Agrostis canina, fascicularis, canina mutica, stolonifera angustifolia, stolonifera cristata, alba, stricta, repens, poa nemoralis, angustifolia.

*Cereal grasses.* Wheat, spelt-wheat, rye and oats, have been sown on poor soils, and cut green and bleached, but are found inferior to the above grasses for the finest plait.

5194. *The period for cutting the culms* is when they are in blossom. They are bleached by pouring boiling water over them, in which they remain ten minutes, and are afterwards spread on a grass plat for seven or eight days. Sinclair found letting the culms remain in hot water from one to two hours required only two or three days bleaching. When bleached they are taken up, washed clean, and put in a moist state in a close vessel, where they are subjected to the fumes of burning sulphur for two hours. Green culms, immersed for ten minutes in a strong solution of acetic acid, and then subjected to the sulphureous acid gas, are bleached perfectly white in half an hour. Green culms, immersed for fifteen minutes in muriatic acid, diluted with twenty times its measure of water, and then spread on the grass, became in four days as perfectly bleached as those culms which were scalded and bleached eight days on the grass. The texture of the straw was not in the least injured by these processes. The application of the sulphureous acid gas to the moistened culms, even after scalding and bleaching on the grass, had, in every instance, the effect of greatly improving the color, and that without being productive of the smallest injury to the texture of the straw. (*Hort. Gram. Wob.* 2nd edit. 427.)

5195. *To imitate the Leghorn plait in the most perfect manner*, the straws should be plaited the reverse way of the common English split-straw plait. In the English plait, the straws are flattened by a small hand-mill made for the purpose, but the Leghorn plait has the straws worked without flattening, and pressure is applied after the plait is made. These two points are essential to be observed by those who wish to rival the finest Leghorn manufacture. By reversing the common mode of plaiting, the fingers have a much greater power in knitting firmly and intimately the straws, and the round or unflattened state of the straws allows of their being more closely knitted; a circumstance that gives an appearance similar to the real Leghorn plait. (*Ibid.*)

## CHAP. VII.

### *Of the Management of Lands permanently under Grass.*

5196. In every country by far *the greater proportion of perennial grass lands is the work of nature*: and it is not till an advanced period in the progress of agriculture that much attention is paid to their management. But as the extension of tillage, planting, and the formation of parks and gardens, limits the range of the domestic animals, their food becomes more valuable; and it then becomes an object to increase it by the culture of roots and artificial herbage on some lands, and by the improved management of the spontaneous productions of others. In a highly cultivated country like Britain, therefore, those lands retained in grass either are, or ought to be, such as are more valuable to the owners in that state than they would be in any other. Such lands naturally divide themselves into two classes: those which are fit either for mowing or pasture; and those which are fit for pasture only.

#### SECT. I. *Perennial Grass Lands fit for mowing, or Meadow Lands.*

5197. *Under the term meadow*, we include all such land as is kept under grass chiefly for the sake of a hay crop, though occasionally, and at particular seasons of the year, it may be depastured by the domestic animals; and we usually include under this term the notion of a greater degree of moisture in the soil, than would be thought desirable either for permanent pasture or lands in tillage. Where hay is in great demand, as near large towns, and especially if a good system of cropping be but little understood, a great deal of arable land may be seen appropriated to hay-crops; but the most valuable meadows are such as are either naturally rather moist, or that are rendered so by means of irrigation. There are three descriptions of these meadows: on the banks of streams and rivers; on the uplands, or more elevated grounds; and bog-meadows; and each of these kinds may be stocked with grasses either naturally or by art, and may be irrigated by one or other of the different watering processes already described. (4053.)

5198. *River-meadows*, or those which are situated in the bottoms of valleys, are in general by far the most valuable. They are the most productive of grass and hay, yielding sustenance for cattle through the summer and the winter, and producing an everlasting source of manure for the improvement of the adjoining lands. The soil is deep and commonly alluvial, having been deposited by water, or washed down from the adjoining eminences; the surface is even from the same cause; and what is of considerable importance, has a gradual declivity or surface-drainage to the river or stream, which almost invariably flows in the lowest part of every valley, and which is essential to this description of meadow. The principal defects to which such lands are liable are, the oozing out of springs towards their junction with the rising lands, and the inundations of the river or stream. The former evil is to be remedied by under-draining, and the latter by

embanking. Such meadows are generally stocked with the best grasses; and their culture consists of little more than forming and keeping open a sufficient number of surface-gutters or furrows to carry off the rain-water; rooting out such tufts of rushes or bad grasses and herbage, as may occasionally appear; destroying moles, and spreading the earth they throw up; removing heavy stock whenever their feet poach the surface; shutting up, bush-harrowing, and rolling at the commencement of the growing season; and finally so adjusting the mowing and pasturing as to keep the land in good heart without laying on manure.

5199. *The most suitable meadows for irrigation* are of this description; the necessary drains and other works are executed with greater care, and with less expense, and the management, as we have seen (4057.), is also comparatively easier than in watering sloping surfaces.

5200. *Upland meadows*, or mowing lands, are next in value to those of valleys. The soil is either naturally good, and well adapted for grass, or, if inferior by nature, it is so situated as to admit of enriching it by ample supplies of manure. Of this last description are the upland meadows, or hay lands of Middlesex; which, though on the most tenacious, and often stony clays, are yet, by the abundance of manure obtained from the metropolis, rendered as productive as the best upland soils employed as hay lands. The roots of perennial grasses, whether fibrous or creeping, never strike deep into the soil; and thus deriving their nourishment chiefly from the surface top dressings of well-rotted manure repeated on the same field for centuries, forms at last a thin black stratum among the roots of the grass, which produces the most luxurious crops.

5201. *The culture of upland meadows* requires more attention and expense than those of valleys; being more difficult to drain, and requiring regular supplies of manure. The irregular surface of uplands is apt either to contain springs or to stagnate the surface water; the first produces marsh plants and coarse herbage, and the latter destroys or weakens whatever is growing on the surface, and encourages the growth of moss. Both evils are to be remedied by the obvious resources of drainage. Moss is a very common enemy to grass lands, and is only to be effectually destroyed by rich dressings of manure. Rolling, and top-dressings of lime and salt, have been recommended for destroying it; but there is no mode by which it can be subdued and kept under, but by adding strength to the grass plants, and thereby enabling them to suffocate their enemy. Moss is never found on rich lands unless they are completely shaded by trees. Besides mole-hills, upland meadows, when neglected, are frequently troubled with ants, which form heaps or hillocks of grass and earth, more injurious and more difficult to get quit of than those of moles. The mode of taking moles is a simple operation, and will be described in the proper place: that of destroying ants is more complicated and tedious, and being peculiar to grass lands, shall here be described.

5202. *Ant-hills, or habitations*, are injurious to meadow lands, by depriving the farmer of a crop in proportion to the surface they occupy, and by interfering with the operations of rolling and mowing. They consist of little eminences, composed of small particles of sand or earth, lightly and artfully laid together, which may often be computed at a tenth part, or more, of old grass lands. And in some places, where negligence has suffered them to multiply, almost half of it has been rendered useless; the hills standing as thick together as grass-cocks in a hay-field: and what is very surprising, this indolence is defended by some, who affirm, that the area or superficies of their land is thereby increased; whereas it is well known that very little or no grass ever grows thereon, and, therefore, if the surface be increased, the produce is proportionably decreased.

5203. *In order to remove ant-hills*, and destroy the insects, it has been a custom in some places, at the beginning of winter, and often when the weather was not very cold, to dig up the ant-hills three or four inches below the surface of the ground, and then to cut them in pieces, and scatter the fragments about: but this practice only disseminates the ants, instead of destroying them, as they hide themselves among the roots of the grass for a little time, and then collect themselves together again upon any little eminence, of which there are great numbers ready for their purpose, such as the circular ridges round the hollows where the hills stood before. It is, therefore, a much better method to cut the hills entirely off, rather lower than the surface of the land, and to let them lie whole at a little distance, with their bottom upwards: by this means the ants, which are known to be very tenacious of their abodes, continue in their habitations until the rains, by running into their holes of communication, and stagnating in the hollows formed by the removal of the hills, and the frosts which now readily penetrate, destroy them. If a little soot were thrown on the places, and washed in with the rains, it would probably contribute greatly to the intended effect. The hills, when rendered mellow by the frosts, may be broken and dispersed about the land. By this method of cutting the hills, one other advantage is gained; the land soon becomes even and fit for mowing, and the little eminences being removed, the insects are exposed to the wet, which is very disagreeable and destructive to them. It would, perhaps, be a better practice than that of suffering the hills to remain on the ground, to collect the parts of them which have been pared off into a heap, in some convenient place, and then form them into a compost, by mixing a portion of quick-lime with them. In wet weather these insects are apt to accumulate heaps of sandy particles among the grass, called by laborers sprout-hills, which quickly take off the edge of the scythe. These hills, which are very light and compressible, may be conveniently removed by frequent heavy rolling.

5204. *In the Norfolk mode of cutting and burning ant-hills*, the process is, to cut them up with a heart-shaped sharp spade or shovel, in irregular lumps of from ten to fifteen inches in diameter, and from two

to five or six inches thick. These are to be turned the grass-side downwards, until the mould-side is thoroughly dry, and then to be set the grass-side outwards, until they are dry enough to burn. The fire may be kindled with brushwood, and kept smothering, by laying the sods or lumps on gradually, as the fire breaks out, until ten or fifteen loads of ashes are raised in one heap, which the workmen formerly completed for a shilling or eighteen-pence each load of ashes. The places from which the hills have been removed may be sown with grass-seeds. Besides the destruction of the ants, this is a ready, though by no means an economical way of raising manure, and in some cases ought not to be neglected, on grounds where such a process is required. On some soils ashes are found in themselves an excellent manure; and, perhaps, generally, ashes raised in this way, would be found highly advantageous as bottomings for farm-yards and dunghills.

5205. *Where grass lands are sufficiently rolled* with a heavy roller once or oftener every year, no ant-hills will ever be formed greater than the roller can compress, and consequently no injury will be sustained. In this, as in most other cases of disease, proper regimen is the best cure. In domestic economy, various directions are given for destroying bugs, lice, and other vermin; but who ever had any to destroy, who attended properly to cleanliness?

5206. *The surface of some grass lands that have been long rolled* are apt to get into that tenacious state denominated *hide bound*. When this is the case, scarifying the turf with a plough, consisting only of coulter, or harrow-teeth, so that the whole surface may be cut or torn, is to be recommended. That tenacious state, rolling tends to increase; whereas, by scarifying, the surface is loosened, and the roots acquire new means of improved vegetation. This operation seems particularly useful, when it precedes the manuring. When hay land of a retentive quality is pastured by cattle or horses in wet seasons, it receives much injury from their feet, and becomes what is technically called poached. Every step they take, leaves an impression, which rain fills with water, and then the hole stands full like a cup. This wetness destroys the herbage, not only in the hole, but that also which surrounds it, while at the same time the roots of the grasses, as well as the ground, are chilled and injured. No good farmer, therefore, will permit any cattle to set a foot on such land in wet weather, and few during the winter months, on any consideration. Sheep are generally allowed to pasture on young grasses in dry weather, from the end of autumn to the beginning of March; they are then removed, and it rarely happens that any animal is admitted till the weather be dry, and the surface so firm as to bear their pressure, without being poached or injured.

5207. In *manuring upland meadows*, the season, the sort, the quantity, and the frequency of application are to be considered.

5208. With regard to the season at which manure should be applied, a great difference of opinion prevails among the farmers of England. In the county of Middlesex, where almost all the grass lands are preserved for hay, the manure is invariably laid on in October (*Middlesex Report*, p. 224.), while the land is sufficiently dry to bear the driving of loaded carts without injury, and when the heat of the day is so moderated as not to exhale the volatile parts of the dung. Others prefer applying it immediately after the hay-time, from about the middle of July to the end of August, which is said to be the "good old time" (*Com. to Board of Agriculture*, vol. iv. p. 138.); and if that season be inconvenient, any time from the beginning of February to the beginning of April, (*Dickson's Practical Agriculture*, vol. ii. p. 915.) It is, however, too common a practice to carry out the manure during frosty weather, when, though the ground is not cut up by the carts, the fertilizing parts of the dung are dissipated, and washed away by the snow and rains before they can penetrate the soil.

5209. *There is scarcely any sort of manure that will not be useful when laid on the surface of grass grounds*; but, in general, those of the more rich dung kinds are the most suitable for the older sort of sward lands; and dung, in composition with fresh vegetable earthy substances, the more useful in the new leys or grass lands. In Middlesex it is the practice of the best farmers to prefer the richest dung they can procure, and seldom to mix it with any sort of earthy material, as they find it to answer the best in regard to the quantity of produce, which is the principal object in view; the cultivators depending chiefly for the sale of their hay in the London markets. It is the practice to turn over the dung that is brought from London in a tolerable state of rotteness, once chopping it well down in the operation, so as to be in a middling state of fineness when put upon the land. It is, necessary, however, that it should be in a more rotten and reduced state when applied in the spring, than when the autumn is chosen for that purpose. (*Dickson's Practical Agriculture*, vol. ii. p. 915.)

5210. *Some interesting experiments have been made with different kinds of manure*, for the purpose of ascertaining their effects, both in regard to the quantity and quality of the produce on different kinds of land. Fourteen lots, of half an acre each, were thus manured, and the grass was made into hay, all as nearly alike as possible. The greatest weight of hay was taken from the lot manured with horse, cow, and butcher's dung, all mixed together, of each about an equal quantity. It lay in that state about two months; and was then turned over, and allowed to lie eight or ten days more, after which it was put on the land before it had done fermenting, and spread immediately. And to ascertain the quality of the produce of the different lots, a small handful from each was laid down on a dry, clean place, where there was little or no grass, and six horses were turned out to them one after another. In selecting the lots, there seems to have been little difference of taste among the horses; and all of them agreed in rejecting two lots, one of which had been manured with blubber mixed with soil, and the other with soot, in both instances laid on in the month of April preceding. (*Lancashire Report*, p. 130. *et seq.*)

5211. *The proportion of manure that is necessary must, in a great measure, depend upon the circumstances of the land, and the facility of procuring it.* In the district of London, where the manure is of a very good and enriching quality, from its being produced in stables and other places where animals are highly fed, the quantity is usually

from four or five to six or seven loads on the acre, such as are drawn by three or four horses, in their return from taking up the hay to town. (*Dickson's Pract. Agr.* vol. ii. p. 916.)

5212. Manure is laid on at intervals of time more or less distant, according to the same circumstances that determine the quantity of it. Though there are some instances of hay grounds bearing fair crops every year during a length of years, without any manure or any advantage from pasturage, except what the after-grass has afforded (*Marshal's Review of Reports to the Board of Agriculture*, p. 183. *Western Department*); yet, in general, manure must either be allowed every third or fourth year, in the land depastured one year, and mown the other; "or what is better, depasture two years and mow the third." (*Northumberland Report*, p. 111.) A succession of hay crops without manure, or pasturage, on meadows not irrigated, is justly condemned by all judicious farmers, as a sure means of impoverishing the soil.

5213. *Bog meadows* are the least valuable of any; they are of two kinds, peat bogs and earthy bogs. The first are situated in hollows or basins, which, from having no natural outlet for water, and not being so deep or so plentifully supplied with that element as to constitute lakes, become filled up with aquatic plants and mosses. By the decay of these after a certain time, and the drainage and culture of art, a surface of mossy soil is formed on which some of the inferior grasses may be sown or will spring up naturally. In warm moist climates and where the mould of the bog is rich, florin or Timothy grass may be found to answer; but in general the woolly soft grass and cock's-foot are resorted to, unless indeed lime be applied, or a coating of sand or earth, in which cases the clovers and better grasses will sometimes answer. These bogs are in general too soft for pasturing any other animals than sheep.

5214. *Earthy bog meadows* are situated either in hollows or on slopes. They are formed by an accumulation of water in the subsoil, which not finding a free passage in any one point, spreads under and filtrates upwards through a considerable extent of surface. The grasses on such meadows before they are drained, are chiefly of the sprot or juncus kind; but by draining the quality of these is improved, and better kinds appear. Such meadows yield a considerable produce of coarse hay; they abound chiefly in cold hilly districts devoted to breeding.

5215. *The culture and management of bog meadows* differs in nothing essential from that of the river kinds. A lighter roller is used in spring, the greatest care is taken in eating down the latter grass, whether by small cattle or sheep; and in some cases, in very dry weather in summer, the main drains are dammed up for a few weeks in order to stagnate the water, and supply the soil with moisture. No manure is ever given unless in the case of some cultivated peat bogs, which are dressed with earthy or saline mixtures.

5216. *As branches of culture common to every description of hay lands* may be mentioned, the hay-making, the application of the after-grass, and pasturage.

5217. *The making of natural or meadow hay* has been carried to greater perfection in the neighborhood of London than any where else, and may therefore, with great propriety, be recommended as an example to the rest of the kingdom. The following account of it is drawn from *Middleton's Agricultural Survey of Middlesex*.

5218. *When the grass is nearly fit for mowing*, the Middlesex farmer endeavors to select the best mowers, in number proportioned to the quantity of his grass and the length of time it would be advisable to have it in hand; which having done, he lets it out, either as piece work, or to be mown by the acre. In the latter way, each man mows from one acre and a half to an acre and three quarters per day; some there are who do two acres per day during the whole season. About the same time he provides five hay-makers (men and women, including loaders, pitchers, stackers, and all others), to each mower. These last are paid by the day, the men attending from six till six, but the women only from eight till six. For an extra hour or two in the evening, when the business requires dispatch, they receive a proportionate allowance.

5219. *The mowers usually begin their work at three, four, or five o'clock in the morning*, and continue to labor till seven or eight at night; resting an hour or two in the middle of the day. Every hay-maker is expected to come provided with a fork and a rake of his own; nevertheless, when the grass is ready, and laborers scarce, the farmer is frequently obliged to provide both, but for the most part only the rake. Every part of the operation is carried on with forks, except clearing the ground, which is done with rakes; and loading the carts, which is done by hand.

5220. *First day.* All the grass mown before nine o'clock in the morning is tedded, in which great care is taken thoroughly to loosen every lump, and to strew it evenly over all the ground. By this regular method of tedding grass for hay, the hay will be of a more valuable quality, heat more equally in the stack, consequently not so liable to damage or fire; will be of greater quantity when cut into trusses, and will sell at a better price; for when the grass is suffered to lie a day or two before it is tedded out of the swath, the upper surface is dried by the sun and winds, and the interior part is not dried, but withered, so that the herbs lose much, both as to quality and quantity, which are very material circumstances. Soon after the tedding is finished, the hay is turned with the same degree of care and attention; and if, from the number of hands they are able to turn the whole again, they do so, or at least as much

of it as they can, till twelve or one o'clock, at which time they dine. The first thing to be done after dinner, is to rake it into what are called single wind-rows; and the last operation of this day is to put it into grass-cocks.

5221. *Second day.* The business of this day commences with tedding all the grass that was mown the first day after nine o'clock, and all that was mown this day before nine o'clock. Next, the grass-cocks are to be well shaken out into saddles (or separate plats) of five or six yards diameter. If the crop should be so thin and light as to leave the spaces between these saddles rather large, such spaces must be immediately raked clean, and the rakings mixed with the other hay, in order to its all drying of an uniform color. The next business is to turn the saddles, and after that, to turn the grass that was tedded in the first part of the morning, once or twice, in the manner described for the first day. This should all be done before twelve or one o'clock, so that the whole may lie to dry while the work-people are at dinner. After dinner, the first thing to be done, is to rake the saddles into double wind-rows; next, to rake the grass into single wind-rows; then the double wind-rows are put into bastard-cocks; and lastly, the wind-rows are put into grass-cocks. This completes the work of the second day.

5222. *Third day.* The grass mown and not spread on the second day, and also that mown in the early part of this day, is first to be tedded in the morning, and then the grass-cocks are to be spread into staddles as before, and the bastard-cocks into staddles of less extent. These lesser staddles, though last spread, are first turned, then those which were in grass-cocks; and next the grass is turned once or twice before twelve or one o'clock, when the people go to dinner as usual. If the weather has proved sunny and fine, the hay which was last night in bastard-cocks, will this afternoon be in a proper state to be carried; but if the weather should, on the contrary, have been cool and cloudy, no part of it probably will be fit to carry. In that case, the first thing set about after dinner, is to rake that which was in grass-cocks last night into double wind-rows; then the grass which was this morning spread from the swaths into single wind-rows. After this, the hay which was last night in bastard-cocks, is made up into full-sized cocks, and care taken to rake the hay up clean, and also to put the rakings upon the top of each cock. Next, the double wind-rows are put into bastard-cocks, and the single wind-rows into grass-cocks, as on the preceding days.

5223. *Fourth day.* On this day the great cocks, just mentioned, are usually carried before dinner. The other operations of the day are such, and in the same order, as before described, and are continued daily until the hay harvest is completed.

5224. *As general rules, the grass should, as much as possible, be protected both day and night, against rain and dew, by cocking.* Care should also be taken to proportion the number of hay-makers to that of the mowers, so that there may not be more grass in hand at any one time, than can be managed according to the foregoing process. This proportion is about twenty hay-makers (of which number twelve may be women), to four mowers; the latter are sometimes taken half a day to assist the former. But in hot, windy, or very drying weather, a greater proportion of hay-makers will be required than when the weather is cloudy and cool. It is particularly necessary to guard against spreading more hay, than the number of hands can get into cocks the same day, or before rain. In showery and uncertain weather, the grass may sometimes be suffered to lie three, four, or even five days in swath. But before it has lain long enough for the under side of the swath to become yellow (which, if suffered to lie long, would be the case), particular care should be taken to turn the swaths with the heads of the rakes. In this state, it will cure so much in about two days, as only to require being tedded a few hours when the weather is fine, previous to its being put together and carried. In this manner, hay may be made and put into the stack at a small expense, and of a moderately good color; but the tops and bottoms of the grass are insufficiently separated by it.

5225. *The hay tedding machine* has been invented since Middleton described the hand process as above. This machine (*fig. 337.*) is found to be a most important saving of manual labor. It is computed that a boy and horse with the machine will ted as much in an hour as twelve or fifteen women. The hay-rake, which may be added to the same axle when the tedder is removed, is also an equal saving, and a requisite accompaniment to it; as where few or no women are kept for tedding, there must necessarily be a deficiency of rakers. These machines are coming into general use near London, where the price of manual labor is high and hands sometimes scarce. They are also finding their way among the proprietors of extensive parks in all parts of the country, as saving much labor in making hay from natural pasture.

5226. *There are no hay-stacks more neatly formed, nor better secured, than those made in Middlesex.* At every vacant time, while the stack is carrying up, the men are employed in pulling it, with their hands, into a proper shape; and, about a week after it is finished, the whole roof is properly thatched, and then secured from receiving any damage from the wind, by means of a straw rope, extended along the eaves, up the ends, and on each side of the ridge. The ends of the thatch are afterwards cut evenly below the eaves of the stack, just of sufficient length for the rain-water to drip quite clear of the hay. When the stack happens to be placed in a situation which may be suspected of being too damp in the winter, a trench, of about six or eight inches deep, is dug round, and nearly close to it, which serves to convey all the water from the spot, and renders it perfectly dry and secure.

5227. *During the hay harvest it is of great advantage to the farmer, to give constant personal attendance on every party, directing each operation as it goes on.* The man who would cure his hay in the best manner, and at a moderate expense, must not only urge the persons who make the hay, the men who load the waggons, and those who make the stack, but he should be on the alert, to contrive and point out the manner in which every person may do his labor to the most advantage. Unless he does this, one



moiety of the people in his hay-field will be of no material use to him; and if he should be absent for an hour or more, during that time, little or nothing will be done. The farmers of Middlesex engage many hay-makers: some of them have been known to employ two or three hundred; such men find it necessary to be on horseback, and the work-people find them sufficient employment. A man of energy will make the most of every hour, and secure his hay while the sun shines: one of an opposite description lounges his time away, and suffers his hay to be caught in the rain, by which it is frequently half spoiled. Or if the latter should have the good fortune of a continuance of dry weather, his hay will be a week longer in the field than his neighbor's, and the sap of it dried up by the sun.

5228. *The waste of grass, on being dried into hay*, is supposed to be three parts in four by the time it is laid on the stack; it is then further reduced, by heat and evaporation, in about a month, perhaps one-twentieth more, or 600lb. of grass are reduced to 95 lb. of hay; and between that and 90, it continues through the winter. From the middle of March till September, the operations of trussing and marketing, expose it so much to the sun and wind, as to render it considerably lighter, probably 80; that is, hay which would weigh 90 the instant it is separated from the stack, would waste to 80 (in trussing, exposure on the road, and at market for about 24 hours), by the time it is usually delivered to a purchaser. During the following winter, the waste will be little or nothing. It is nearly obvious, that the same hay will weigh on delivery 80 in summer, and 90 in winter. From this circumstance, and others which relate to price, a farmer may determine what season of the year is the most advisable for him to sell his hay.

5229. *In making the hay of bog meadows*, considerable care is requisite both from the inferiority of the climates where such bogs abound, and from the nature of the grasses they produce. In some cases, the grass is of so soft a quality, that it is difficult to convert it into hay. To prevent its being consolidated in the cocks, it must be frequently opened up, and when the weather permits, completely exposed to the sun and wind; this sort of grass being only capable of sustaining a very moderate degree of fermentation.

5230. *When the natural herbage is of a coarser description*, it may be put into small cocks, in rather a green or damp state, so as to go through the progress of "a sweating," or slight fermentation. The woody fibres in coarse hay, are thus rendered more palatable and nutritious, while its condition for becoming fodder, is considerably improved: but when any warmth becomes perceptible, if the weather will permit it, the hay should be spread out, and put into large cocks the moment it is in a dried state.

5231. *In the moister pastoral districts*, in the north-west parts of Scotland, hay-barns are necessary, the construction of which is as open as possible, for the purpose of drying, as well as preserving the hay. In some of these districts, a curious device has been fallen upon, of making the hay, when dried, into ropes of two fathoms in length, and then twisted twofold. Being thus compressed, less room is required in the barn, and in this shape, it is carried, with greater facility, to distant glens, for the use of cattle during stormy weather.

5232. *In making florin hay* (if hay it may be called, which is never dried) it is merely cut and put into small cocks, from which it is commonly taken as wanted. When it is to be put into larger cocks, it must be proportionally better dried. The stolons of this grass being remarkably vivacious, cannot easily be so dried as to admit of stacking in large bodies.

5233. *The salting of hay*, at the time of stacking, has been practised in Derbyshire and in the North Riding of Yorkshire. The salt, particularly when applied to the crop of roun, or when the first crop has received much rain, checks the fermentation, and prevents moulding. If straw be mixed with the hay, the heating of the stack is still further prevented, by the straw imbibing the moisture. Cattle will eat, not only such salted hay, but even the straw mixed with it, more eagerly than better hay not salted, and also thrive as well upon it. The quantity recommended is, a peck of ground rock salt to a ton of hay. By this application, hay that had been flooded, was preferred by cattle to the best hay that had not been salted.

5234. *To make hay-tea*. Boil at the rate of a handful of hay to three gallons of water, or if the water be poured boiling hot on the hay, it will answer nearly as well. Give it to the cattle and horses to drink when cold; or if the cattle and horses are anyways ill, and under cover, give it them blood warm. This drink is so extremely nutritive, that it nourishes the cattle astonishingly, replenishes the udders of the cow with a prodigious quantity of milk, makes the horse stale plentifully, and keeps him healthy and strong; and by this method one truss or hundred of hay will go as far as eight or ten otherwise would do. The cattle and horses do not seem to like it at first; but if they are kept till they are very thirsty, they will drink freely of it ever afterwards. The hay after being used as before-mentioned and dried, may be used as litter for horses and cattle; it will make very good manure, and save straw, which is a considerable advantage, especially where there is a scarcity of that article. (*Davis's Rep. of Wüts.*)

5235. *The after-grass on all meadows* is generally fed off; on firm lands, and in the dry season, by either sheep or heavy cattle; but in the winter only by sheep, unless the soil is so dry as not to be injured by the feet of cows or horses. The feet of the latter are

much less injurious than those of the former; but their bite being closer is more apt to tear up the plants, than the bite of the horned tribe. In Middlesex cattle are generally removed from meadow-lands in November; horses in the month following, and sheep allowed to remain till February. In Lincolnshire, Leicestershire, and on many river-meadows, every description of stock is allowed to remain till April, and sheep to May. In some districts, the whole of the after-growth is preserved from every species of stock till the following May, when it is fed off for sheep: but this greatly retards the hay crop for that year. It is evident that a good deal must depend on the farmer's other resources for keep to his stock.

5236. *The after-grass, where manure is very abundant*, is sometimes made into hay or rouen, a soft and not very nutritive food, given to cows or sheep; but this is reckoned a bad practice, even in the neighborhood of London, where manure may be had in abundance. It is also the usage of some to leave the after-grass on the ground without being eaten till spring, when it is said to be preferable, for ewes and lambs, to turnips, cabbages, or any other species whatever of what is termed spring-feed. This mode of management, which is strongly recommended by Young, and in some cases by Marshal also, is unknown in the north, where, though it is, in many instances, found beneficial, with a view to an early spring growth, not to eat the pasture too close before winter, it would be attended with a much greater loss of herbage, than any advantage in spring could compensate, to leave the after-growth of mown grounds untouched till that season.

5237. A system of *alternate mowing and feeding* is practised on some hay lands, partly to save labor and manure, and partly to subdue mosses and coarse grasses. On some soils even rich grass lands, when annually mown, become subject to weeds; for it tends to encourage moss, and gives advantage to the stronger rooted grasses, which gradually change, and deteriorate the nature and quality of the herbage. The bottom becomes thin, the white clover disappears, and coarser plants occupy the ground. When this takes place, the pasture should be fed, instead of being mown, for the space of two or three years, until the weeds have been subdued, and the finer grasses re-appear.

5238. By adopting the plan of mowing and feeding alternately, a farmer, it is said, may go on longer without the application of manure, but his fields, in the end, will be ruined by it. It is contended, that to maintain a proper quantity of stock, the land must be accustomed to keep it, particularly in the case of sheep; that where land has been used to the scythe, if manured for pastures, it will often produce more grass, but that grass will not (*cæteris paribus*) support so much stock, nor fatten them nearly so well; and that old pasture will not produce so much hay as land that has been constantly mowed; for each will grow best as they have been accustomed to grow, and will not readily alter their former habits. On the other hand, it is asserted, that many experienced farmers prefer the system of feeding and mowing alternately, as they find, that under that system, the quality and quantity of the hay has been improved; and the pasturage, in the alternate year, has been equally sweet and productive.

## SECT. II. *Of permanent Pastures.*

5239. *Permanent pastures* may be divided into two kinds: rich or feeding lands; and hilly or rearing pastures. Under the former, we may comprehend all old rich pastures that are capable of *fattening* cattle; and under the second, such as are adapted to *rearing* them only, or are more advantageously depastured with sheep.

### SUBJECT. 1. *Of rich or feeding Pastures.*

5240. *Feeding pastures* may include such as are equally fit for hay-lands, or for being converted to arable husbandry; their characteristic being, that they are used for feeding stock, and keeping working animals and milk-cows in good condition. We have mentioned in a former chapter, that pasturage for one, two, or more years, is frequently interposed in the course of cropping arable land, to prevent that exhaustion of the soil which is commonly the consequence of incessant tillage crops. The same culture and management that is recommended here for rich grass lands, is equally applicable to them; there being no difference, excepting that the latter are generally considered less suitable for fattening heavy stock, such as large oxen, than rich old turf.

5241. *The culture and management of feeding pastures*, whether of a few years or perpetual duration, may be considered in regard to those necessary operations that have been already noticed, under the former section,—such as the extirpation of weeds and noxious shrubs, clearing away ant and mole-hills, the application of manure, the time of stocking, the number of the animals, and whether all should be of one or of different species,—the extent of the enclosures, and the propriety of eating the herbage close, or leaving it always in a rather abundant state; all these are questions which it is scarcely possible to decide in a satisfactory manner, by the application of general rules. They can only be resolved, with any pretensions to utility, by a reference to the particular circumstances of each case; for the practice of one district, in regard to these and other points, will be

found quite inapplicable to others where the soil and climate, and the purposes to which the pastures are applied, are materially different.

5242. *The weeding of pastures* should be regularly attended to. Weeds in pastures injure the farmer by the ground they occupy, the seeds they disperse, and sometimes, by influencing the quality of milk, or the health of the cattle. Small creeping weeds cannot be removed on the large scale of a farm; but large perennial plants, such as the dock, fern, nettle; and biennials, such as the thistle, ragweed, together with rushes and coarse tufts, or tussocks of tall oat-grass, should never be permitted to shoot up into flower. The dock ought to be taken out by the root with the dock-weeder, and the others cut over with spadlets or spuds. Nettles may be mown over, as may some other weeds, and some descriptions of rushes and fern is most effectually killed by bruising or twisting asunder the stem, when the frond or herb is nearly fully expanded. Smaller weeds may be mown, and this operation should never be deferred later than the appearance of the flowers. Where the sloe-thorn forms part of the enclosure-hedges, or the English elm, hoary poplar, and some other trees, grow in or around the field, they are apt to send up suckers; these should be pulled up, otherwise they will soon become a serious nuisance. In some parts of England, especially in the central districts, the hedge wastes, from the spread of the sloe-thorn and creeping rose (*Rosa arvensis*), are sometimes six or ten yards in width.

5243. *To prevent the growth of mosses* is one of the greatest difficulties in the management of old pasture lands; by these the finer species of grasses are apt to be overwhelmed, and the coarse sorts only remain. Drainage, and the use of rich composts, are in this case necessary. Harrowing and cross harrowing with a common harrow, or with what are called grass harrows (fig. 586.), which go from one to two inches deep, with a sprink-

586

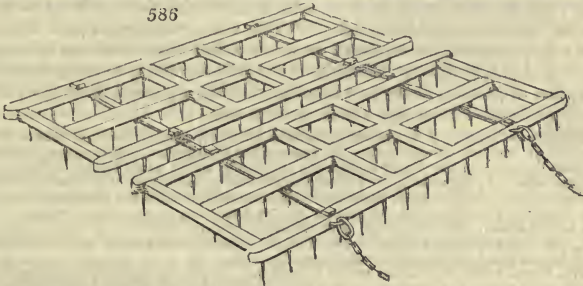

ling of grass-seeds afterwards, and some lime or well prepared compost, are the most likely means of destroying the moss, and improving the pasture. Feeding sheep with oil cake, and allowing them to pasture on the land, has also been found effectual for the destruction of moss, and bringing up abundance of grass. But the radical remedy is to plough up such grass lands upon the first appearance of moss, or before it has made any considerable progress, and sow them with corn.

5244. *The removal of ant and mole-hills* should be attended to during the whole summer. The manner of destroying ants has already been described; mole-hills spread on grass lands may be considered as of service rather than otherwise. These operations, together with weeding, and spreading the manure dropped by the larger stock, should go on together at intervals during the whole summer.

5245. *The application of manures* to grazing lands, which not being used as hay grounds afford no means of supply, may certainly be considered a preposterous practice, and one that must be ruinous to the other parts of a farm; yet in *The Code of Agriculture* it is stated, that "to keep grass in good condition, a dressing of from thirty to forty cubic yards or cart-loads of compost, is required every four years. The application of unmixed putrescent manure will thus be rendered unnecessary, which ought at least to be avoided, in meadows appropriated for the feeding of dairy cows, from its affecting the quality of the milk." (p. 476.) Grass lands kept at an expense of this kind will seldom, it is believed, be found to remunerate a farmer sufficiently. The same thing is recommended (probably from inadvertence or mere following the tract of preceding writers), in *Dickson's Practical Agriculture*, vol. ii. p. 953. But, excepting the dung dropped by the pasturing animals, which should always be regularly spread from time to time, it may be laid down as a rule of pretty extensive application, that if grass lands do not preserve their fertility under pasturage, it would be much better to bring them under tillage for a time, than to enrich them at the expense of land carrying crops of corn. (*Sup. &c. art. Agr.*)

5246. *Teething or stacking* on the field, or carrying to be consumed there during winter, the provender that ought to have furnished disposable manure for the use of the farm at large, is another practice not less objectionable. It is to no purpose that such a wasteful practice is defended, on dry light soils which are alleged to be thus benefited by the treading of the cattle. (*Marshal's Rural Economy of Yorkshire*, vol. ii.

p. 131.) During the frequent and heavy falls of rain and snow in winter, there is scarcely any land so dry as not to be injured by the treading of heavy cattle; and were there any thing gained in this respect by this management, it would be much more than counterbalanced by the loss of a great part of the manure, from the same cause. The able writer to whom we have just now referred, very properly disapproves of carting on manure in winter; and for the same reason, namely, the loss of it, which must necessarily be the consequence, he ought to have objected to foddering on the land, or teathing at that season. The practice, however, is but too common in those districts, both in South and North Britain, where the knowledge of correct husbandry has made but little progress. It is equally objectionable, whether the fodder be consumed on meadows where it grew, or on other grass lands. The fodder should, in almost every instance, be eaten in houses or fold-yards, instead of the dung being dropped irregularly over the surface; or, as must be almost always the case, accumulated in some spots sheltered by trees and hedges, to which the animals necessarily resort during the storms of winter.

5247. *The time of stocking pastures* in spring, must evidently be earlier or later, according to the climate, and in the same climate according to the season; and the state of growth, which it is desirable that the grass should attain before being stocked, must in some degree be determined by the condition and description of the animals to be employed in consuming it; whether they are only in a growing state or approaching to fatness; whether milk cows or sheep, or a mixture of animals of different species. It conveys no very precise idea respecting these points, though the remark itself is just, to say that the herbage should not be allowed to rise so high as to permit the coarser plants to run to seed; and that it is bad management to suffer store stock to be turned upon a full bite. (*Marshal's Yorkshire*, vol. ii. p. 129.) The great objects to be aimed at are, that the stock, of whatever animals it may consist, should be carried forward faster or slower, according to the purposes of their owner; and that no part of the herbage should be allowed to run to waste, or be unprofitably consumed. But nothing but careful inspection of the land and of the stock, from time to time, can enable any grazier to judge with certainty what are the best measures for attaining these objects. "Fattening cattle," says Marshal, "which are forward in flesh, and are intended to be finished with grass, may require a full bite at first turning out. But for cows, working oxen, and rearing cattle, and lean cattle intended to be fattened on grass, a full bite at the first turning out is not requisite. Old Lady-day to the middle of April, according to the progress of spring, appears to me, at present, as the best time for shutting up mowing grounds and opening pastures." (*Marshal's Yorkshire*, vol. ii. p. 152, 153.)

5248. In regard to *the state of the growth of pastures when first stocked*, some distinction should be made between new leys and old close swards. To prevent the destruction of the young plants, whether of clover or other herbage, on the former description of pasture, which would be the consequence of stocking them too early, especially with sheep, they should be allowed to rise higher than would be necessary in the case of old turf; and to secure their roots from the further injury of a hot summer, it is advisable not to feed them close in the early part of the season, and probably not at any time throughout the whole of the first or second season, if the land is to be continued in pasture. The roots of old and firm sward, on the other hand, are not in so much danger, either from close feeding or from the heats of summer; and they are in much less danger from the frosts and thaws of winter.

5249. With regard to *the stock which should be employed*, all soils rather moist and of such a quality, as is the case with rich clays, as to produce herbage suited to the fattening of cattle, will, in general, be more advantageously stocked with them than with sheep; but there can be no other rule for the total exclusion of sheep, than the danger of the rot; nor any other general rule for preferring one kind of stock to another, than their comparative profits. (*Sup. art. Agr.*)

5250. *Whether the stock should be all of one or of different kinds*, is another question to be discussed. With regard to a mixed stock, the sentiments and practice of the best graziers seem to be in its favor. "It is generally understood that horses and cattle intermixed will eat grass cleaner than any species will alone, not so much from their separately affecting different grasses, as from the circumstance of both species disliking to feed near their own dung." (*Marshal's Yorkshire*, vol. ii. p. 154.) "Some few graziers follow the old custom of keeping only one kind of stock upon the same ground, whilst others, we think, with more propriety, intermix with oxen and cows a few sheep, and two or three colts in each pasture, which both turn to good account, and do little injury to the grazing cattle. In some cases sheep are a real benefit, by eating down and destroying the ragwort (*Senecio jacobæa*), which disgraces some of the best pastures of the county, where oxen only are grazed." (*Northumberland Report*, p. 126.) And in Lincolnshire, where grazing is followed to a great extent, and with uncommon success, as well as in most other districts, the practice seems to be almost invariably, to keep a mixed stock of sheep and cattle on the same pasture (*Lincolnshire Report*, p. 174.), in proportion varying with the nature of the soil and the quality of the herbage.

5251. *To estimate the number of animals that may be depastured on any given extent of ground*, is obviously impossible, without reference to the particular spot in question; and the same difference exists with regard to the propriety of feeding close, or leaving the pastures rough, that prevails in most other parts of this subject. Though there be loss in stocking too sparingly, the more common and dangerous error is in overstocking, by which the summer's grass is not unfrequently entirely lost.

5252. *With respect to the size of enclosures*, small fields are much to be preferred to large ones, for heavy stock. Besides the advantages of shelter, both to the animals and the herbage, small fields enable the grazier either to separate his stock into small parcels, by which means they feed more at their ease, or to give the best pastures to that portion of them which he wishes to come earliest to market. The advantages of moderate sized enclosures are well known in the best grazing counties; but the subdivisions are in some

instances much more minute than is consistent with the value of the ground occupied with fences, or necessary to the improvement of the stock. In all cases, says Marshal, where fattening cattle or dairy cows make a part of the stock, and where situation, soil, and water will permit, every suit of grazing grounds ought, in my idea, to consist of three compartments. One for head stock (as cows or fattening cattle); one for followers (as rearing and other lean stock); and the third to be shut up to freshen for the leading stock. (*Marshal's Yorkshire*, vol. ii. p. 158.)

5253. *Large enclosures* are in general best adapted for sheep. These animals are not only impatient of heat and liable to be much injured by flies, in small pastures often surrounded by trees and high hedges, but they are naturally, with the exception perhaps of the Leicester variety, much more restless and easily disturbed than the other species of live stock. "Sheep," says Lord Kaimes, "love a wider range, and ought to have it, because they delight in short grass: give them eighty or ninety acres, and any fence will keep them in; confine them to a field of seven or eight acres, and it must be a very strong fence that keeps them in." (*Gentleman Farmer*, p. 203.) Though fields so large as eighty or ninety acres, can be advisable only in hilly districts, yet the general rule is nevertheless consistent with experience, in regard to all our least domesticated varieties.

5254. *With respect to the propriety of eating the herbage close, or leaving it rather in an abundant state*, an eminent agriculturist observes, that there seems to be a season, some time during the year, when grass lands, particularly old turf, should be eaten very close, not merely for the sake of preventing waste, but also for the purpose of keeping down the coarser kinds of plants, and giving to the pastures as equal and fine a sward as possible. The most proper period must partly depend upon the convenience of the grazier; but it can hardly be either immediately before the drought of summer or the frost of winter. Some time in autumn, when the ardent heat of the season is over, and when there is still time for a new growth before winter, may be most suitable for the land itself, and generally also for the grazier, his fat stock being then mostly disposed of, or carried to the after-grass of mown grounds. The sweeping of pastures with the scythe, may be employed as a substitute for this close feeding; the waste and labor of which, however, though they be but trifling, it does not seem necessary to incur on rich grazing lands, under correct management. (*Sup. E. Brit. art. Agr.*)

5255. *Fogging pasture lands* is a practice which is sometimes adopted in districts where there is a scarcity of winter food. Under that system, fields in pasture are shut up early in May, and continued in that state till November or December, when the farmer's stock is turned in, and continue to pasture, till the May succeeding. Such management, however, can only be advisable on a soil of the driest nature, which will not be injured by poaching in the wettest seasons. It is practised in a few places in Cardiganshire; but is considered by Thos. Johnes, Esq. of Havod, as being the result of necessity, the farmers not being able to bring sufficient stock to eat it down in season, when its nutritive powers are in their best state.

5256. *Water* should be provided for every field under pasture; and also shelter and shade, either by a few trees, or by a portable shed, which may be moved with the stock from one enclosure to another. Where there are no trees, rubbing posts are also a desirable addition. In Germany they have portable sheds which are employed both in summer and winter, and generally with a piece of rock-salt fixed to a post for the cattle to suck at. (*fig. 587.*)

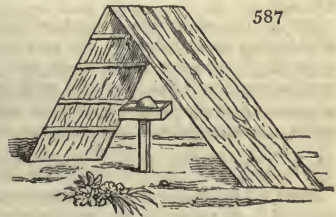

#### SUBJECT. 2. *Of Hilly and Mountainous Pastures.*

5257. *Hilly pastures* include such low hills as produce fine short herbage, and are with much advantage kept constantly in pasture, though they are not altogether inaccessible to the plough; as well as such tracts as, from their acclivity and elevation, must necessarily be exclusively appropriated to live stock. The former description of grass lands, though different from the feeding pastures, of which we have just treated, in respect of their being less convenient for tillage management, are nevertheless in other circumstances so nearly similar, as not to require any separate discussion. These low hills are for the most part occupied with sheep, a very few cattle being sometimes depastured towards their bases; and they frequently comprise herbage sufficiently rich for fattening sheep, together with coarser pastures for breeding and rearing them.

5258. *In regard to the management of upland pastures*, of the rules which judicious farmers practise, the following deserve to be selected. To enclose those pastures, as the same extent of land, when sheltered, and properly treated, will feed a greater

quantity of stock, and to better purpose, than when in an open and exposed state. Not to overstock upland pastures; for when this is done, the cattle are not only starved, and the quantity of herbage diminished, but the soil is impoverished. When the pasture ground is enclosed and subdivided, so as to admit of it, the stock ought to be shifted from one enclosure to another, at proper intervals; giving the first of the grass to the fattening, in preference to the rearing stock. This practice tends to increase the quantity of grass, which has thus time to get up; and the ground being fresh and untainted, when the stock returns to it, more especially if rain has fallen, they will feed with greater appetite and relish. The dung dropt by the stock, while feeding, should be spread about, instead of its being suffered to remain, in a solid body, on the place where it was dropt. Where the large and the smaller kinds of stock are to be fed on the same pastures, the larger species should have the first bite; and it is not thought by some advisable to pasture land with a mixed collection of different species of live stock, unless the field be extensive, or unless the herbage varies in different parts of the field. It is generally found, that the grass produced by the dung of cattle or horses, is injurious to sheep, producing grass of too rich a quality for that species of stock. There is no mode by which such pastures are more effectually improved, than by the application of lime, either spread upon the surface, or mixed with the soil. In the latter case, it is essential, that the lime should be mixed with the surface soil only; as lime is apt to sink, if covered deep by the plough. The coarse grasses would, in that case, regain possession of the soil, and the dung afterwards deposited by the cattle, will not enrich the land in the same manner as if the lime had been incorporated with the surface only. (*Code.*)

5259. *Mountainous pastures*, from which the plough is altogether excluded, have been commonly classed among waste lands; even such of them as bear herbage by no means of inconsiderable value; as well as heaths and moors, with patches of which the green pastures are often chequered. The general term wastes, is therefore a very indefinite expression; and, indeed, is not unfrequently made to comprehend all that extensive division of our territory that neither produces corn nor rich herbage. Yet it is on such tracts that by far the greater part of our butcher's meat and wool is grown, and not a little of the former fully prepared for the market. Foreigners and superficial readers at home must accordingly be greatly mistaken, if they imagine that what are called *wastes*, by the Board of Agriculture, and other writers on rural economy, are really altogether unproductive; and it would still be a grosser error to believe, that all those wastes owe their continuance to neglect or mismanagement; and that any exertions of human industry can ever render the greater part of them, including all the mountainous tract of Great Britain, more valuable than they are at present, without a much greater expenditure of capital, than, under almost any circumstances, they could possibly return. (*Sup. art. Agr.*)

5260. *The chief improvements of which mountainous pastures are susceptible*, are those of draining and sheltering by plantations. Some parts might probably be enclosed by strips of plantation between stone walls, or by stone walls alone; but as the stock on mountain pastures are generally under the care of a herdsman, the advantages of change of pasture and alternate eating down and saving or sparing the grass, by keeping out the cattle, are obtainable without the use of fields.

### SECT. III. *Of the Improvement of Grass Lands, by a temporary Conversion to Tillage.*

5261. *The practice of breaking up grass lands*, either with a view to their being soon after restored to that state, or to their permanent retention in aration, has occasioned much discussion, and even attracted the attention of the Legislature, and the Board of Agriculture. In *The Code of Agriculture*, it is stated, that a "much larger proportion of the united kingdom, than is at present so cultivated, might be subject to the alternate system of husbandry, or transferred from grass to tillage, and then restored to grass. Much of the middling sorts of grass lands, from 200 to 400 feet above the level of the sea, is of this description; and all well-informed husbandmen, and friends to the general prosperity of the country, regret, that such lands are left in a state of unproductive pasturage, and excluded from tillage.

5262. *A very extensive inquiry* was made, in consequence of a requisition from the House of Lords to the Board of Agriculture, in December 1800, "into the best means of converting certain portions of grass lands into tillage, without exhausting the soil, and of returning the same to grass, after a certain period, in an improved state, or at least without injury;" and the information collected by the Board, upon that subject, is in the highest degree satisfactory and important.

5263. On this subject the *opinion of one of our first writers* is, "that though it be impossible to deny that much grass land in England would be more productive, both to the proprietor and occupier, under a good course of cropping, than under pasture; yet it is no less certain, that there are large tracts of rich grazing land, which, in the present state of the demand for the produce of grass lands, and of the law of England, with regard to tithes, cannot be employed more profitably for the parties concerned, than in pasture. The interest which the Board of Agriculture has taken in this question, with

a view to an abundant supply of corn for the wants of a rapidly increasing population, seems, therefore, not to have been well directed. Instead of devoting a large portion of their volumes to the instruction of farmers, regarding the best method of bringing grass lands into tillage, and restoring them again to meadow or pasture, without deterioration; the first thing required was, to attempt removing the almost insuperable obstruction of tithes, by proposing to the legislature an equitable plan of commutation. If some beneficial arrangement were adopted on this head, there is no reason to doubt, that individual interest would soon operate the wished-for change; and that all grass lands capable of yielding more rent and profit under tillage than under pasture, would be subjected to the plough, as fast as the demands of the population might require. (*Sup. E. B. art. Agr.*)

5264. In giving the *essence of the information collected by the Board*, we shall first state the opinions as to such grass lands as should not be broken up, and next the directions for breaking up and laying down the others.

SUBJECT. 1. *Of Grass Lands that ought not to be broken up by the Plough.*

5265. *There are various sorts of grass lands that ought not to be broken up; as water meadows; salt marshes; lands apt to be overflowed; lands near large populous towns, where the produce of grass land is always in demand, and consequently dear; and low lying tracts, in the valleys of mountainous countries, particularly in chalky districts where old meadow land is scarce, and where a portion of it, to raise early and late food for stock, gives a great additional value to the adjoining upland. But whether rich lands, which have long remained in grass, and continue productive, should ever be converted into tillage, is a question respecting which a great diversity of opinion has been entertained.*

5266. *The lands considered as best adapted for permanent pasture, are of three kinds: strong tenacious clays, unfit for turnips, or barley, which are said to improve the more, the longer they are kept under a judicious system in grass; soft clayey loams, with a clayey or marly bottom or substratum; and, rich sound deep-soiled land, or vale land, enriched by nature at the expense of the higher grounds, generally lying in a situation favorable with respect to climate.*

5267. *The advantages of such pastures are represented in the strongest light. It is affirmed that they feed cattle to a greater weight; that they are not so easily scorched by the summer's drought; that the grasses are more nutritive both for sheep and cattle; that milch cows fed upon them give richer milk, and more butter and cheese; that the hoofs of all animals pastured on them are much better preserved; that they produce a greater variety of grasses; that when properly laid down, they yield a succession of pasture throughout the whole season; that the herbage is sweeter, and more easily digested; and that they return an immense produce at a trifling expense.*

5268. *To break up lands possessing these advantages, it is said, can only be justified by the most urgent public necessity, and to prevent the horrors of famine. The real value of such lands will appear, by considering their rent and produce. The grass lands in Lincolnshire are accounted the richest in the kingdom. The rents are various, from 1*l.* 1*s.* to 3*l.* per acre, and the value of the produce from 3*l.* per acre to 10*l.* This produce arises from beef, mutton, and wool, and is obtained, subject to little variation from the nature of the seasons, and at a trifling expense. The stock maintained per acre on the best grazing lands, surpasses what could be fed by any arable produce. It is not at all uncommon to feed at the rate of from six to seven sheep in summer; and about two sheep in winter. The sheep when put on the grass may weigh from 18 lbs. to 20 lbs. per quarter, and the increase of weight would be at the rate of 4 lbs. per quarter, or 16 lbs. per sheep. But suppose in all only 100 lbs. at 8*d.* per pound, that would amount to 3*l.* 17*s.* 10*d.* The wool would be worth about two guineas more, besides the value of the winter keep, and the total may be stated at about seven pounds per acre, got at little expense. Such lands, it is evident, cannot be better employed than in feeding stock.*

5269. *Grass land on tenacious clays and heavy loams, when brought in a succession of years, or perhaps of ages, into a state of great productiveness, cannot be ploughed without the risk of great injury, and are more profitable in the production of herbage than they could be in the production of grain.*

5270. *Grass on deep-soiled sound vale lands, would be productive of corn if ploughed; but would probably be injured by cultivation; from their texture being altered, and rendered unduly loose and open by tillage; from the native plants being more or less destroyed or enfeebled; and from the great decomposition and waste of the principles of fertility resident in the soil.*

5271. *The extent of these descriptions of land, however, is not so great, that the advantages of breaking them up could probably ever be a national object, or worth the risk of injuring their future productiveness in grass. But there are pasture lands of an inferior sort which are too apt to be confounded with those already described, and res-*

pecting the propriety of occasionally appropriating them to arable culture, there can hardly be a doubt. Such lands do not depend upon their intrinsic fertility, but upon annual supplies of manure derived from the arable land in their neighborhood.

SUBJECT. 2. *Of the Advantages and Disadvantages of breaking up Grass Lands.*

5272. *The advantages of breaking up grass lands, not of the richest quality, will appear by a comparison of their produce with that of arable lands.* From the inquiry of the Board of Agriculture, it appears that an acre of clover, tares, rape, potatoes, turnips, cole, or cabbages, will furnish at least thrice as much food as the same acre would have done had it remained in pasture of a medium quality; and consequently, that the same extent of land would maintain at least as much stock as when in grass; besides producing every other year a valuable crop of corn; and this, independently of the value of the straw, which, whether consumed as litter, or as food for cattle, will add considerably to the stock of manure. It follows that with the exception of rich pastures, arable land is, on an average, superior to grass land with respect to furnishing articles of human food in the proportion of three to one; and consequently every piece of land, unnecessarily kept in grass, the produce of which will only maintain one person, is depriving the community of food, capable of maintaining two additional members.

5273. *The principal objection to the conversion of old turf into arable land, arises from an alleged inferiority in the new when compared to the old herbage; a complaint which probably originates either from the improper choice of seeds, or from giving them in too small quantities, thus favoring the growth of weeds.* A gentleman who had a large farm, principally consisting of strong rich clay, (every field of which, with hardly an exception, he occasionally broke up) was accustomed to lay them down with a crop of barley, and to sow fourteen pounds of white clover, a peck of rib-grass, and three quarters of hay-seeds per acre. By this liberal allowance of seed, he always secured a thick coat of herbage the first year, which differed from old pasture only in being more luxuriant. Such lands, therefore, under judicious management, will rarely be injured by the plough. When laid down from tillage into grass, they may not carry for the first year or two, such heavy cattle as they would afterwards, but they will support more in number, though of a smaller size, and bring a greater weight of butcher meat to market. It is often desirable to keep one or two moderate-sized enclosures, of from ten to twenty acres, according to the size of the farm, in perennial pasture, for the feeding of cattle and sheep; and as a resource for the stock to go to in case of a severe spring, or summer drought; but the retaining of any considerable portion of a farm in old turf, or permanent pasture, unless of the richest quality, is, in general, injurious to the landlord, the tenant, and the public. The value of any estate, where the system of permanent pasture has been carried to an unreasonable extent, may be easily and greatly augmented by appropriating the manure of the farm to turnips and other green crops, and by the adoption of the convertible system of husbandry.

5274. *There are many cases where this doctrine, though in general to be recommended, ought not to be carried to its full extent.* In Norfolk, where the land is commonly light, and where sheep are both bred and fed upon the same farm, a proportion of permanent pasture is essential. Much injury in particular has been sustained by breaking up permanent pastures on such soils, more especially when subject to rectorial tithes. Many lands of an inferior soil, which kept two sheep on an acre, paying only vicarial tithes, and rented at ten shillings per acre, since they have been broken up, cannot pay, even without rent, the tithe of corn and the expense of cultivation. A farm in general lets best, with a fair proportion of grass land upon it, which admits of a mixed management, in consequence of which, if one object fail, another may be successful.

5275. *With respect to the disadvantages of breaking up pastures, it is alleged in The Code of Agriculture, that there is a risk of tenants breaking through their engagements (p. 473, 3d edit.), by which we suppose is to be understood their chance of their taking a few good crops from the newly-broke-up lands, and then leaving the farm.* Tenants who would do this must certainly be as wicked, as the landlords who would put it in their power would be imbecile. No other disadvantage is stated, and this may safely be left to work its own cure.

SUBJECT. 3. *Of breaking up Grass Lands, and afterwards restoring them to Grass.*

5276. *On the subject of breaking up and laying down grass lands, the following particulars are discussed in The Code of Agriculture, as the result of the information communicated to the Board.* Whether any previous steps are necessary before lands in grass are broken up; the proper mode of effecting that object; the course of crops; the manure necessary; the system of management during the rotation; the mode of laying down the land again to grass; that of sowing the grass-seeds; and, the subsequent management.

5277. *If the land be wet, it is advisable to drain it completely, previous to its being*



broken up; for it is not improbable that its being kept in pasture was partly on account of its wetness. Land that has been long in pasture does not require dung during the first course of crops that is taken after being broken up; but the application of calcareous manure is always, in such cases, expedient. Sometimes lime is spread on the ground before it is ploughed; at other times when it is either under summer-fallow, or a drilled crop of turnips. Marl and chalk also have been used for the same purpose with great advantage. The land thence derives additional strength and vigor; the succeeding crops are much improved; the soil is commonly so softened in its texture, that it may be ploughed with half the strength that would otherwise be necessary; and whenever it is restored to grass, the herbage is abundant.

5278. *Wherever the soil is not too shallow*, nor of a friable nature, or when the turf cannot soon be rotted, if land is to be broken up from old pasture, paring and burning is the proper system to be adopted. In this way, good tilth is speedily procured; the damage that might otherwise be sustained by the grub, the wire-worm, and other insects, is avoided, while the soil receives a stimulus which ensures an abundant crop. Where paring and burning, from any circumstance, cannot take place, the land may be trenched or double-ploughed. This is effected by means of two ploughs following each other, the first plough taking off a thin surface of about three inches, and the second going deeper in the same place, covering the surface-sod with fine mould; both furrows not exceeding the thickness of the vegetable mould or other good soil. If the land is ploughed with one furrow, the operation ought to be performed before winter, that it may receive the benefit of the succeeding frosts, by which the success of the future operations will not only be promoted, but most of the insects lodged in the soil will be destroyed. When one furrow alone is taken, the best size is four inches and a half deep by eight or nine broad. The strain on horses in ploughing ley land is mostly from the depth.

5279. *The rotation of crops to be adopted*, when grass lands are broken up, must partly depend upon the soil, and partly on the manner in which it is prepared for cultivation. As a general principle, however, it may be laid down, that unless by the course of cropping to be pursued the bad grasses and other plants indigenous in the soil are extirpated, they will, when the land is again laid down to grass, increase and prevail with more rapidity and effect than seeds chosen by the farmer; and the consequence must be, a heavy disappointment in the future crops of grass, perhaps solely, or at least principally, attributable to a previous defective management. It is necessary, therefore, to enter into details upon this subject as applicable to clay, chalk, peat, loam, and sand.

5280. *Clay*. The process of conversion in clayey soils should be commenced with paring and burning, especially where the grub is suspected. The following course may then be adopted:—1. rape, fed with sheep; 2. beans; 3. wheat; 4. beans; 5. wheat; 6. fallow; 7. wheat, sown with grass-seeds. This may seem severe cropping, but is justified by experience when old grass clay land is broken up. If the land has not been pared and burnt, the first crop ought to be either oats or dibbled beans. To do justice to the plan of restoring the land to grass, there ought to be, in all cases, according to the soil, either a naked or turnip fallow, before the sowing of grass-seeds be attempted. But on mellow loamy clay land, consisting of fine old grass pasture, where it is thought necessary or advisable to break up such land, it should be done in detached pieces, so as to suit the convenience of the occupier, and the following course should be adopted:—1. autumnal ploughing for oats in spring; 2. fallow for rape, to be eaten with sheep; 3. beans; 4. wheat, sown with clover; 5. clover; 6. clover; 7. wheat; 8. rape, to be partially eaten, and hoed in spring, and to stand for seed; and 9. wheat with grass-seeds. This is a very profitable rotation, and applicable to the best grazing land in Lincolnshire.

5281. *Chalk*. Paring and burning is considered in this case to be indispensable as a preparation for turnips, which ought, where manure can be got, to be raised two years in succession; then, barley, clover, wheat; and, after one or two additional crops of turnips, the land may be laid down with saintfoin to great advantage.

5282. *Peat*. On this soil paring and burning is essentially necessary. Under a judicious system, the greatest and quickest profit is thus secured to the farmer, with advantage to the public, and without injury to the landlord. Draining also must not be neglected. The crops to be grown on peat soils are, 1. rape or potatoes; 2. oats; 3. turnips; 4. oats or wheat; and 5. clover or grass-seeds. A liberal application of lime, where it can be obtained, is of the greatest service in enabling such soils to bring corn to its full perfection. In the fens of Thorney, the following course was recommended:—1. paring and burning for rape; 2. oats; and 3. wheat with grass-seeds; if the land was safe from water, the Lammas sort, if not, spring wheat. This short course, it is contended, preserves the land in heart; and it afterwards produces abundant crops of grass. But long courses, in such a soil, run the lands to weeds and straw, without quality in the grain.

5283. *Loam*. The courses of crops applicable to this soil are too numerous to be here inserted. If the sward be friable, the following rotation may be adopted:—1. oats; 2. turnips; 3. wheat or barley; 4. beans; 5. wheat; 6. fallow or turnips; 7. wheat or barley, and grass-seeds. If the sward be very tough and coarse, instead of taking oats, it may be pared and burnt for turnips.

5284. *Sand*. On rich and deep sandy soils, the most valuable crop that can be raised is carrots. For inferior sands, turnips, to be eaten on the ground, then to be laid down with barley and grass-seeds.

5285. *According to the improved system of laying down lands to grass*, land ought to be previously made as clean and fertile as possible. With that view, all the green crops raised ought to be consumed upon the ground; fallow or fallow crops ought not to be neglected; and the whole straw of the corn crops should be converted into manure, and applied to the soil that produced it. Above all, the mixing of calcareous matter with the soil, either previous to, or during the course of cropping, is essential. Nothing generally improves meadows or pastures more than lime or marl: they sweeten the herbage, render it more palatable to stock, and give it more nourishing properties.

5286. *When turnips are raised upon light land, sheep should be folded on them; whereas, if the land be strong or wet, the crop should be drawn, and fed in some adjoining grass-field, or in sheds. If the land be in high condition, it is customary to cart off half the turnips, and eat the other on the ground. But this is not a plan to be recommended on poor soils.*

5287. *It has been disputed whether grass-seeds should be sown with or without corn. In favor of the first practice, that of uniting the two crops, it is maintained, that where equal pains are taken, the future crop of grass will succeed equally well as if they had been sown separately, while the same tilth answers for both. On the other hand, it is observed, that as the land must, in that case, be put into the best possible order, there is a risk that the corn-crop will grow so luxuriantly, as to overpower the grass-seeds, and, at any rate, will exclude them from the benefit of the air and the dews. If the season also be wet, a corn-crop is apt to lodge, and the grass will, in a great measure, be destroyed. On soils moderately fertile, the grasses have a better chance of succeeding; but then, it is said, that the land is so much exhausted by producing the corn-crops, that it seldom proves good grass land afterwards. In answer to these objections, it has been urged, that where from the richness of the soil, there is any risk of sowing a full crop of corn, less seed is used, even as low as one-third of the usual quantity; and that a moderate crop of grain nurses the young plants of grass, and protects them from the rays of a hot sun, without producing any material injury. Where the two crops are united, barley is the preferable grain, except on peat. Barley has a tendency to loosen the texture of the ground in which it grows, which is favorable to the vegetation of grass-seeds. In the choice of barley, that sort should be preferred which runs least to straw, and which is the soonest ripe. On peat, a crop of oats is to be preferred.*

5288. *The manner of sowing the grass-seeds, also, requires to be particularly attended to. Machines have been invented for that purpose, which answer well, but they are unfortunately too expensive for the generality of farmers. It is a bad system, to mix seeds of different plants before sowing them, in order to have the fewer casts. It is better, to sow each sort separately, for the expense of going several times over the ground is nothing, compared to the benefit of having each sort equally distributed. The seeds of grasses being so light, ought never to be sown in a windy day, except by machinery, an equal delivery being a point of great consequence. Wet weather ought likewise to be avoided, as the least degree of poaching is injurious. Grass seeds ought to be well harrowed, according to the nature of the soil.*

5289. *When the corn is carried off, the young crop of grass should be but little fed during autumn, and that only in dry weather; but heavily rolled in the following spring, in order to press the soil home to the roots. It is then to be treated as permanent pasture. By attention to these particulars, the far greater proportion of the meadows and pastures in the kingdom, of an inferior, or even medium quality, may be broken up, not only with safety, but with great profit to all concerned.*

## CHAP. VIII.

### *Of Plants cultivated on a limited Scale for various Arts and Manufactures.*

5290. The plants used as food for men and animals, are by far the most generally cultivated in every country, and next, *those of clothing, building, and other arts of convenience or luxury.* The former are often called agricultural, and the latter commercial or manufactory plants. Of manufactory plants, only a few are at present cultivated in Britain; the national policy rendering it preferable to import them, or substitutes, from other countries. Some, however, are still grown in nearly sufficient quantities for home consumption, as the hop, mustard, rape, canary, and a considerable quantity of flax, anise, carraway; and some hemp, teazle, and woad are also raised. These and other plants may be classed as grown for the clothing, distilling, brewing, oil making, domestic, and medical arts.

#### SECT. I. *Of Plants grown chiefly for the Clothing Arts.*

5291. *The clothing plants are flax, hemp, teazle, madder, woad, and weld; the three first are used by the manufacturer of the fabric, and the others by the dyer.*

SUBSECT. 1. *The Flax. — Linum usitatissimum, L. Pentan. Pentag. L. and Caryophyllea, J. Lin, Fr.; Flacks, Ger.; and Lino, Span. and Ital. (fig. 588 a.)*

5292. *The flax has been cultivated from the earliest ages, and for an unknown length of time in Britain, of which it is now considered a naturalised inhabitant. It is cultivated both for its fibre for making thread, and its seed for being crushed for oil; but never has been grown in sufficient quantity for either purpose. The legislature of the country, as Brown observes, has paid more attention to framing laws regarding the husbandry of flax than to any other branch of rural economy; but it need not excite surprise that these laws, even though accompanied by premiums, have failed to induce men to act in a manner contrary to their own interest. The fact is, the culture of flax is found on the whole less profitable than the culture of corn. It is one of the most severe crops when allowed to ripen its seed; but by no means so when pulled green.*

5293. *The varieties of the common flax are few, and scarcely deserving of notice. Marshal mentions the blue or lead-colored flax as being cultivated in Yorkshire, and Professor Thær mentions a finer and coarser variety; he also, as*



well as some other agriculturists, has tried the *Linum perenne* (*b*), but though it affords a strong fibre, it is coarse and difficult to separate from the woody matter.

5294. *The soils* most proper for flax, besides the alluvial kinds, are deep and friable loams, and such as contain a large proportion of vegetable matter in their composition. Strong clays do not answer well, nor soils of a gravelly or dry sandy nature. But whatever be the kind of soil, it ought neither to be in too poor nor in too rich a condition; because, in the latter case, the flax is apt to grow too luxuriant, and to produce a coarse sort; and, in the former case, the plant, from growing weakly, affords only a small produce. (*Tr. on Rural Affairs*.)

5295. *If there be water at a small depth below the surface* of the ground, it is thought by some still better, as is the case in Zealand, which is remarkable for the fineness of its flax, and where the soil is deep and rather stiff, with water almost every where, at the depth of a foot and a half or two feet underneath it. It is said to be owing to the want of this advantage, that the other provinces of Holland do not succeed equally well in the culture of this useful plant; not but that fine flax is also raised on high lands, if they have been well tilled and manured, and if the seasons are not very dry. It is remarked, in the letters of the Dublin Agricultural Society, that moist stiff soils yield much larger quantities of flax, and far better seed, than can be obtained from light lands; and that the seed secured from the former may, with proper care, be rendered full as good as any that is imported from Riga or Zealand. M. Du Hamel, however, thinks that strong land can hardly yield such fine flax as that which grows on lighter ground.

5296. *The place of flax in a rotation of crops* is various, but in general it is considered as a corn or exhausting crop, when the seed is allowed to ripen; and as a green, or pea, or bean crop, when the plant is pulled green. Flax, Donaldson observes, is sown after all sorts of crops, but is found to succeed best on lands lately broken up from grass. In Scotland, the most skilful cultivators of flax generally prefer lands from which one crop of grain only has been taken, after having been several years in pasture. When such lands have been limed or marled, immediately before being laid down to grass, the crop of flax seldom or never misgives, unless the season prove remarkably adverse. In the north of Ireland flax is generally sown by the small farmers after potatoes. In Belgium, it is supposed not to do well after pease or beans; nor to succeed if sown oftener on the same soil than twice in nine years. (*Von Thaer*.)

5297. *The preparation of the soil*, when grass land is intended for flax, consists in breaking it up as early in the season as possible, so that the soil may be duly mellowed by the winter frosts, and in good order for being reduced by the harrows, when the seed process is attempted. If flax is to succeed a corn crop, the like care is required to procure the aid of frost, without which the surface cannot be rendered fine enough for receiving the seed. Less frost, however, will do in the last, than in the first case; therefore, the grass land ought always to be earliest ploughed. At seed-time, harrow the land well before the seed is distributed, then cover the seed to a sufficient depth, by giving a close double tine of the harrows. Water-furrow the land, and remove any stones and roots that may remain on the surface, which finishes the seed process.

5298. *The ordinary season of sowing flax seed* is from the middle of March to the middle or end of April, but the last week of March and the first ten days of April is esteemed the best time; and accordingly within these periods the greatest quantity of flax-seed is sown in this country. In France and Italy it is often sown in the autumn, by which a larger crop is produced, especially when seed is desired.

5299. *The quantity of seed* depends on the intention of the crop. When a crop of seed is intended to be taken, thin sowing is preferable, in order that the plants may have room to throw out lateral shoots, and to obtain air in the blossoming and filling seasons. But it is a mistake to sow thin when flax is intended to be taken, for the crop then becomes coarse, and often unproductive. From eight to ten pecks per acre, is the proper quantity in the last case, but when seed is the object, six pecks will do very well. (*Brown*.) Thick-sown flax runs up in height, and produces fine soft flax; if sown thin, it does not rise so high, but spreads more and puts forth many side branches, which produce abundance of seed, and such seed is much better filled, plump, and heavy, than the seed produced from thick-sown flax. (*Donaldson*.)

5300. *In the choice of seed*, that which is of a bright brownish color, oily to the feel, and at the same time weighty, is considered the best. Linseed, imported from various countries, is employed. That brought from Holland is, however, in the highest estimation, as it not only ripens sooner than any other that is imported, but also produces greater crops, and flax of that quality which best suits the chief manufactures of the country. American seed produces, in common, fine flax, but neither the quantity of flax nor of the pods, provincially the "bolls," which contain the seeds, is so large as the produce from Dutch linseed. Riga seed yields a very coarse sort of flax, but a greater quantity of seeds than any other. It is common in some parts of Scotland to sow seeds saved from the crop of the preceding year, especially when that crop was raised from seed imported from Holland. The success of this practice is found to depend greatly on changing the seed from one sort of soil to another of an opposite nature; but the saving in the expense of purchasing that sort of seed, in place of what is newly imported from

Holland, is so inconsiderable, and the risk of the crop misgiving so much greater in the one case than in the other, that those only who are ignorant of the consequences, or who are compelled from necessity, are chargeable with this act of ill-judged parsimony. Flax seed is by some farmers changed every three years, but many have sown the same seed ten years in succession without perceiving any degeneracy. When any degeneracy takes place, the seed of flax grown on a different soil, as moss, moor, sand, &c. without any view to the produce in fibre, will, it is said, answer as well as foreign seed.

5301. *The manner of sowing* is almost always the same, but when seed is the main object, drilling may be adopted, by which seed will be saved in sowing, cleaning conducted at less expense, and the plants rendered more vigorous and branchy by the stirring of the soil, and the admission of air between the rows. The fibres of flax grown in this way, however, will be shorter and less equal in thickness throughout their length, than flax grown by the broad-cast mode, and tolerably thick.

5302. *The after-culture of flax* consists chiefly in weeding, but sometimes it commences with rolling the surface, which is a very proper operation when the soil is very dry, the season advanced, or the earth very porous. By this process the earth is pressed firmly to the seeds, and they are thereby stimulated to vegetate sooner, and the drought is kept out. On some soils, and in wet or stormy seasons, flax is apt to be laid, to guard against which some cultivators run across their flax field slender poles fixed to stakes; but a better method is to run small ropes across the field, both lengthwise and breadthwise, where necessary, for these being fastened where they intersect one another, and supported by stakes at due distances, form a kind of net-work, which is proof against almost every accident that can happen from tempestuous weather.

5303. *In Scotland* a crop of flax is sometimes weeded by turning a flock of sheep at large into the field. They will not taste the young flax plants, but they carefully search for the weeds, which they devour.

5304. *The flax crop is taken by pulling*, on which there is a considerable difference of opinion. None, however, think of pulling it before it comes into flower, when fibre is the sole object; or before the seed in the capsules acquires a brownish color, when fibre and seed jointly, or seed alone, is the object. Some argue for pulling while it is green, in order that its fibres may be softer and finer: others, with the same view, pull it up before its seeds are quite formed; and others again think that it should not be pulled till some of the capsules which contain the seeds have begun to open, being of opinion that the fibres of green flax are too tender, and that they fall into tow. On the other hand, it is certain the fibres of flax which has stood till it is very ripe, are always stiff and harsh, that they are not easily separated from the reed, and that they do not bleach well. Here, therefore, as in most other cases, both extremes should be avoided, and it consequently seems most reasonable to think that the properest time for pulling flax, is when its stalks begin to turn from a green to a yellow, when its leaves begin to fall, and when its seeds begin to be brown. Donaldson observes, that a crop of flax frequently grows short, and runs out a great number of seed-bearing branches. When that is the case, the seeds, not the flax, ought to be the farmer's chief object, and the crop should be allowed to stand till the seeds are in a great measure perfected. But that when the crop thrives, and is likely to become more valuable for the flax than the seeds, it should be pulled soon after the bloom drops off, and before the pods turn hard and sharp in the points. When flax is grown for its fibre, Brown considers it the safest course to take it a little early, any thing wanting in quantity, being, in this way, made up by the superiority of quality.

5305. *The operation of pulling flax* differs according to the intention of the crop. When it is grown for the fibre it is pulled and tied immediately into sheaves like corn, being carried off immediately to be watered. But when the seed is to be taken from the plant, it is pulled and laid in handfuls.

5306. *In pulling flax*, it is usual, when it is intended to save the seeds, to lay it in handfuls, partly across each other; the reason for which is, that the business of rippling is thereby facilitated, as the rippers, in place of having to separate each handful from the bundle, find it by this simple precaution already done to their hand. Although it is of much importance, yet it very seldom happens, that much attention is bestowed to separate the different sorts of flax from each other, in pulling the crop. In most fields, there are varieties of soils; of course some parts of a field will produce fine flax; others coarse; some long; and some short: in a word, crops of different lengths and qualities. It cannot be supposed that all these sorts of flax will undergo an equal degree of watering, grassing, breaking, and heckling, without sustaining great injury.

5307. *As the flax is pulled*, it is laid together by handfuls, with the seed end turned to the south. These handfuls should neither lie quite in a line with each other, nor directly across, but a little slanting upwards, so that the air may easily pass through them. Some, instead of this method, tie the handfuls of flax loosely at the top, then spread out their roots, and thus set several of them together upright upon their roots. In either of these ways, the flax is generally left twelve or fourteen days in the field to dry it. This drying is certainly not necessary for the rippling, because the ripple will separate the capsules from the flax as effectually before it has been dried as it will afterwards; and if it be done with a view to ripen the seed, it should be considered, that the flax will be more hurt by the longer time of steeping, which will become necessary in consequence of this drying, than the seed can be benefited; because, the more the membrane which connects the fibres to the reed is dried, the greater must be the degree of putrefaction necessary to loosen and destroy the cohesion of this connecting membrane; the

finer parts of the flax itself must necessarily be destroyed by this degree of putrefaction; and if the putrefaction does not arise to such a degree as to destroy the cohesion of this membrane, the fibres of the flax will adhere so strongly to the reed, that the force necessary in scutching will prove equally detrimental to the flax. The practice adopted in some parts of Britany seems therefore much more rational, which is, to ripple the flax after it has lain in the air two or three days; but even one day will be sufficient, if the weather is dry.

5308. *In the process of rippling*, which is the next operation, a large cloth should be spread on a convenient spot of ground, with the ripple placed in the middle of it. In performing this business, the pods containing the seeds are forced from the stalks by means of the iron comb called a ripple, fixed on a beam of wood, on the ends of which two persons sit, who, by pulling the seed end of the flax repeatedly through this comb, execute the operation in a very complete manner. It is remarked by the author of *The Present State of Husbandry in Great Britain*, that "those who bestow much attention on the cultivation of flax in Scotland generally ripple off the seed, even when there is no intention of saving it; as it is found, when flax is put into water without taking off the pods, the water soon becomes putrid, in consequence of which the flax is greatly injured."

5309. *The management of the capsules and separation of the seed*, is the next operation. The capsules obtained should be spread in the sun to dry, and those which separate from the pods of their own accord being the fullest and ripest, should be set apart for sowing, in case the precaution of raising some flax purposely for seed has not been attended to. The capsules are then broken, either by treading or by threshing, in order to get out the remaining seeds, the whole of which, as well as the former, should be carefully sifted, winnowed, and cleaned. When the seed is laid up, it must be frequently stirred, or ventilated, to prevent its heating. Even this second seed affords a considerable profit, by the oil which it yields, and also by being used when broken for fattening of cattle.

5310. *To facilitate the separation of the fibre from the bark*, it is necessary to accelerate the process of decay or putrefaction. This may be done in different ways, but the chief are those of bleaching alone, or of steeping and bleaching. Bleaching is a tedious and laborious operation when it is intended as a substitute for steeping, but it is the most certain for not injuring the fibre, and may be adopted on a small scale when steeping places are not at hand. In Dorsetshire, and some other places, flax, instead of being steeped, is what is called dew-retted; that is, the stalks are allowed to arrive at that state in which the harl or woody parts, separate most easily from the boon, reed or fibre, by a more gradual process, that of ripening by the action and influence of the dew. This is nothing more than exposing the flax to the influence of the weather for a longer period than is necessary, when the operation of watering has been previously performed. Steeping, however, is the most universal practice both in Britain and on the continent. Of late, an invention has been made by Lee of Middlesex, by which with the aid of soft soap and machinery, the fibre is more completely separated than by steeping, and uninjured by that process. When flax is to be separated by this new process, the cultivator has only to pull it in handfuls, dry it, bind it into sheaves or faggots, and put it up in stacks like corn, till wanted by the manufacturer.

5311. *Steeping or watering*, however, is and will be the general practice till flax dressing machines come into universal use. In performing this operation, the flax, whether it has been dried and rippled, or pulled green, is loosely tied into small bundles, the smaller the better, because it is then most equally watered. These sheaves ought to be built in the pool in a reclining upright posture, so that the weight placed above may keep the whole firm down. The weights made use of are commonly stones placed on planks, or directly on the flax.

5312. *The Flemish mode of steeping flax*, as described by Radcliff, is said to improve the quality of the flax; and greatly increase its whiteness. This mode differs from the common practice, in placing the bundles in the steep vertically, instead of horizontally; in immersing the flax by means of transverse sticks, with that degree of weight annexed which shall not push it down to the bottom, but leave it the power to descend spontaneously towards the conclusion of the steepage; and in leaving at first a space of at least half a foot between the bottom and the roots of the flax. The spontaneous descent of the flax is an indication of its being sufficiently steeped; and the strength and quality of the fibre are said to be much better preserved by this mode, in which the temperature of the atmosphere acts with most force on the upper part of the plant, which needs it most.

5313. *The water most proper for steeping flax* should be clear, soft, and in standing pools. Compared with running water, pools occasion the flax to have a better color, to be sooner ready for the grass, and even to be of superior quality in every respect. When soft clear stagnating water cannot be obtained without art, a pit or canal is commonly formed, adjoining to a river or stream, whence water can be easily brought. This pit or canal is filled with water for some time (a week or two) before it be proposed to pull the flax; by this means the water acquires a greater degree of warmth than river-water possesses, and which contributes greatly to facilitate the object farmers have in view in

immersing green flax in water, namely, to make the harl or flaxy substance part easily and completely from the boon or reed.

5314. *The period that flax ought to remain in the water*, depends on various circumstances; as the state of ripeness in which it was pulled, the quality and temperature of the water, &c. The most certain rule by which to judge when flax is sufficiently watered, is, when the boon becomes brittle, and the harl separates easily from it. In warm weather, ten days of the watering process is sufficient; but it is proper to examine the pools regularly after the seventh day, lest the flax should putrefy or rot, which sometimes happens in very warm weather. Twelve days will answer in any sort of weather; though it may be remarked, that it is better to give too little of the water, than too much, as any deficiency may be easily made up by suffering it to lie longer on the grass, whereas an excess of water admits of no remedy. (*Brown.*)

5315. *Grassing or bleaching flax* is the next operation, the intention of which is to rectify any defect in the watering process, and carry on the putrefactive process to that point when the fibre will separate from the bark, boon, reed or harl, (as the woody part of the stem is called) with the greatest ease. In performing this operation, the flax is spread very thin on the ground, and in regular rows; the one being made to overlap the other a few inches, with a view of preventing, as much as possible, its being torn up and scattered by gales of wind. Old grass-ground, where the herbage does not grow to any great height, is the best for the purpose; as when the grass or weeds spring up so as to cover the flax, it is frequently rotted, or at least greatly injured thereby.

5316. *The time allowed for grassing* is regulated by the state of the flax, and seldom exceeds ten or twelve days. During this time it is repeatedly examined, and when it is found that the boon has become very brittle, so that, on being broken, and rubbed between the hands, it easily and freely parts from the harl, it is then taken up, a dry day being chosen for the purpose, and, being bound in sheaves, is either sent directly to the mill, which is the usual practice in the northern districts, or broken and scutched, by a machine or implement for the purpose.

5317. *Steeping flax in hot water and soft soap* (said to be the invention of Lee, and for which he was granted by parliament a secret or unenrolled patent) is said to separate the fibre from the woody matter better than steeping in water; and this in the short space of two or three hours, and either with green flax, or such as has been dried and stacked for months or years.

5318. *The dressing of flax* consists of various operations, such as scutching, tracking, or breaking, by which the woody part is broken; and heckling or combing, by which the fibre is separated from the woody part, and sorted into lengths. These operations are often all performed by the cottager, or small farmer, who grows flax for the purpose of spinning the fibre in his own family. But there are also public flax mills, impelled by water or other powers, by which flax is scutched, and it is then heckled by professed hecklers.

5319. *A method of preparing flax in such a manner as to resemble cotton in whiteness and softness*, as well as in coherence, is given in *The Swedish Transactions* for the year 1747. For this purpose a little sea-water is to be put into an iron pot or an untinned copper-kettle, and a mixture of equal parts of birch-ashes and quick-lime strewed upon it; a small bundle of flax is to be opened and spread upon the surface, and covered with more of the mixture, and the stratification continued till the vessel is sufficiently filled. The whole is then to be boiled with sea-water for ten hours, fresh quantities of water being occasionally supplied in proportion to the evaporation, that the matter may never become dry. The boiled flax is to be immediately washed in the sea by a little at a time, in a basket, with a smooth stick at first, while hot; and when grown cold enough to be borne by the hands, it must be well rubbed, washed with soap, laid to bleach, and turned and watered every day. Repetitions of the washing with soap expedite the bleaching; after which the flax is to be beat, and again well washed; when dry, it is to be worked and carded in the same manner as common cotton, and pressed betwixt two boards for forty-eight hours. It is now fully prepared and fit for use. It loses in this process near one-half its weight, which, however, is abundantly compensated by the improvement made in its quality.

5320. *Lee's method of breaking flax and hemp, without dew-retting*, was invented in 1810, and was the first step towards a great improvement, brought nearer perfection by the new patent machines of Messrs. Hill and Bundy.

5321. *Hill and Bundy's machines* (fig. 589.) are portable, and may be worked in barns or any kind of out-house; they are also well-calculated for parish work-houses and charitable institutions; a great part of the work being so light that it may be done by children and infirm persons; and such is the construction and simplicity of the machines, that no previous instruction or practice is required; their introduction, therefore, into those asylums, would be the means of effecting a considerable reduction of the poor's rate. The woody part is removed by a very simple machine; and, by passing through a second

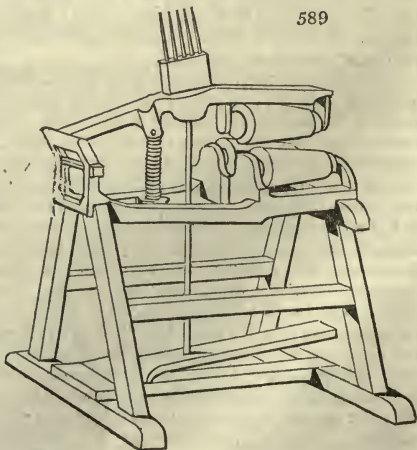

machine equally simple, the flax may be brought to any degree of fineness, equal to the best used in France and the Netherlands, for the finest lace and cambric. The original length of the fibre, as well as its strength, remains unimpaired; and the difference of the produce is immense, being nearly two-thirds; one ton of flax being produced from four tons of stem. The expense of working each ton obtained by this method is only five pounds. The glutinous matter may be removed by soap and water only, which will bring the flax to such perfect whiteness, that no further bleaching is necessary, even after the linen is woven; and the whole process of preparing flax may be completed in six days.

5322. *The produce of flax in seed* is generally from six to eight, sometimes as high as ten or twelve, bushels per acre; and the price depends, in a great measure, on that of foreign seed imported; as, when sold to oil-makers, it is generally about one half of that of Dutch seed sold for the purpose of sowing. The price of home-cultivated linseed is considerably advanced of late in some of the southern and western counties of the kingdom, in proportion to what it is in those of the northern, owing to the circumstance of its being much used as food for fattening cattle. The average price of the linseed cultivated in the kingdom at large, cannot, it is supposed, be rated higher than from three to four shillings the bushel. The seed is separated into three qualities; the best for sowing; the second best for crushing for oil; and the inferior for boiling or steaming for cattle.

5323. *The produce of flax in fibre* varies exceedingly. Before being sorted, the gross product of fibre varies from three cwt. to half a ton per acre.

5324. *The use of flax* in the linen manufacture is well known. The seed is crushed for oil, which is that in common use by painters; the cake or husk which remains, after the expression of the oil, is sold for fattening cattle, and in some places as a manure; and the inferior seed not fit to crush, is boiled and made into flax-seed jelly, esteemed an excellent nutriment for stock.

5325. As the *making of flax-seed jelly* is an agricultural operation, we shall here describe it. The proportion of water to seed is about seven to one. Having been steeped in part of the water eight-and-forty hours, previous to the boiling, the remainder is added cold, and the whole boiled gently about two hours, keeping it in motion during the operation to prevent its burning to the boiler; thus reducing the whole to a jelly-like, or rather a gluey or ropy consistence. After being cooled in tubs, it is given, with a mixture of barley-meal, bran, and cut chaff; a bullock being allowed about two quarts of the jelly per day, or somewhat more than one quart of seed in four days: that is, about one-sixteenth of the medium allowance of oil-cake.

5326. *The diseases of flax* are few, and chiefly the fly, which sometimes attacks the plants when young, and the mildew and rust.

SUBJECT. 2. *Hemp*. — *Cannabis sativa*, L. *Diæcia Pentandria*, L. and *Urticæ*, J. *Chanvre*, Fr.; *Hanf*, Ger.; *Canamo*, Span.; and *Canapa*, Ital.

5327. *The hemp* is a plant of equal antiquity with the flax. It is supposed to be a native of India, or of some other Asiatic country, being too tender to be even naturalized in Europe. It is one of the few plants employed in British agriculture, in which the male and female flowers are in different plants, a circumstance which has some influence on its culture and management. It grows to a great height on good soils, sometimes to six or seven feet in this country, but in Italy generally higher; and Crud states that he has seen it fifteen feet eight inches high in the Bolognese territory, and a friend of his eighteen feet six inches: in both cases the fibre being of remarkable beauty. This luxuriance of the hemp in warm countries may be one reason why it has never been much cultivated in England. In the isle of Axholme, in Lincolnshire, it has been cultivated from time immemorial, and also for some centuries in Suffolk, but chiefly for local manufacture. The culture, management, and uses of hemp, are nearly the same as of flax. When grown for seed it is a very exhausting crop; but when pulled green, it is considered a cleaner of the ground, and is said to have the property of preserving from insects any crop which it may surround. The objections to this crop are, that its coming in the midst of harvest is embarrassing; and that the attention it demands in every state of its progress is too great, where it is only a secondary consideration.

5328. *The soils* most suitable for hemp are those of the deep black putrid vegetable kind, which have a situation low, and somewhat inclined to moisture, as well as the deep mellow loamy or sandy sorts. But the quantity of produce is in general much greater on the former than the latter; though, according to some, of an inferior quality. Mellow rich clayey loams do well; and nothing better than old meadow land.

5329. *The preparation of the soil*, and place in the rotation, are the same as for flax.

5330. *The season of sowing* is towards the end of April, when there is no longer any danger of frost injuring the rising plants. The quantity of seed is from two to three bushels, according to the quality of the land. In quality the seed must be fresh, heavy, and bright in color. Broad-cast is the universal mode of sowing, and the only after-culture consists in keeping off birds when it is coming up; in weeding, and sometimes in supporting the crop by cross rods or lines, as in the case of flax. (5302.)

5331. In *taking the hemp crop*, two methods are in use according to the object in view. When the crop is grown entirely for the fibre, it is pulled when in flower, and

no distinction made between the male and female plants. But as it is most commonly grown, both with a view to fibre and seed, the usual practice is to pull the male plants as soon as the setting of the seed in the females shews that they have effected their purpose. As the female plants require four or five weeks to ripen their seeds, the males are thus pulled so long before them.

5332. In the operation of pulling the males, the pullers walk in the furrows, between the ridges, and reach across to the crown of the ridge, pulling one or two stalks at a time, and carefully avoiding to tread down the female plants. The male stalks are easily known by their yellowish hue, and faded flowers. They are tied in small bundles, and immediately carried to the watering pool, in the manner of flax.

5333. The operation of pulling the females commences when the seed is ripe, which is known by the brownish or greyish hue of the capsules and fading of the leaves. The stalks are then pulled and bound up into bundles, being set up in the same manner as grain, until the seed becomes so dry and firm as to shed freely; great care should be taken at pulling not to shake the stalks rashly, otherwise much of the seed may be lost. It is advised, that, after pulling the seed, hemp may be set to stand in shocks of five sheaves to dry the seed; but, in order to prevent any delay in watering, the seed-pods may be cut off with a chopping-knife, and dried on canvass exposed to the air, under some shed or cover. This last method of drying the seed will prove of great advantage to the hemp, as the seed and pods, when green, are of such a gummy nature, that the stems might suffer much by sun-burning or rain; which will discolor and injure the hemp before the seed can be sufficiently dried upon the stalks. Besides, the threshing-out the seed would damage the hemp in a considerable degree.

5334. Hemp is watered (provin. water-retted), bleached (provin. dew-retted), and grassed in the same manner as flax. Grassing is omitted in some places, and drying substituted; and in other districts watering is omitted with the female crop, which is dried and stacked, and dewed or bleached the following spring. On the continent hot-water and green soap has been tried, and here, as in the case of flax, it is found that steeping two hours in this mixture, is as effectual in separating the fibre from the woody matter, as watering and grassing for weeks.

5335. Although hemp in the process of manufacturing, passes through the hands of the breaker, heckler, spinner, whitester, weaver, and bleacher; yet many of these operations are frequently carried on by the same person. Some weavers bleach their own yarn and cloth, others their cloth only; some heckle their tow, and put it out to spinning, others buy the tow, and put it out; and some carry on the whole of the trade themselves.

5336. The produce of hemp in fibre, varies from 3 to 6 cwt. per acre; in seed from 11 to 12 bushels.

5337. The uses of hemp are well known, as well as its great importance to the navy for sails and cordage. Exceeding good huckaback is made from it, for towels and common table-cloths. The low-priced hempen cloths are a general wear for husbandmen, servants, and laboring manufacturers; the better sorts for working farmers and tradesmen in the country; and the finer ones, seven-eighths wide, are preferred by some gentlemen, for strength and warmth. They possess this advantage over Irish and other linens, that their color improves in wearing; whilst theirs declines, English hemp, properly manufactured, stands unrivalled in its strength, and is superior in this respect to the Russian. Considerable quantities of cloth are imported from that country for sheeting merely on account of its strength, for it is coarser at the price than other linen. Our hempen cloth, however, is preferable, being stronger from the superior quality of the thread, and at the same time lighter in washing. The hemp raised in England is not so dry and spongy a nature as what we have from Russia and India, and therefore it requires a smaller proportion of tar to manufacture it into cordage. Tar being cheaper than hemp, the rope-makers prefer foreign hemp to ours, because they can make a greater profit in working it: but cordage must certainly be stronger in proportion, as there is more hemp and less tar in it, provided there be a sufficient quantity of the latter to unite the fibres. An oil is extracted from the seeds of hemp, which is used in cookery in Russia, and in this country by painters. The seeds themselves are reckoned a good food for poultry, and are supposed to occasion hens to lay a greater quantity of eggs. Small birds in general are very fond of them, but they should be given to caged birds with caution, and mixed with other seeds. A very singular effect is recorded, on very good authority, to have been sometimes produced by feeding bullfinches, and goldfinches, on hemp-seed alone, or in too great quantity; viz. that of changing the red and yellow on those birds to a total blackness.

5338. The hemp has few or no diseases.

SUBJECT. 3. *The Fuller's Thistle, or Teazle.*—*Dipsacus fullonum*, L. *Tetran.* Mon. L. and *Dipsacæ*, J. *Chardon à foulon*, Fr.; *Kardendistel*, Ger.; *Cardencha*, Span.; and *Dissaco*, Ital. (fig. 590.)

5339. *The fuller's thistle* is a herbaceous biennial, growing from four to six feet high; prickly or rough in the stem and leaves, and terminated by rough burr-like heads of flowers. It is a native of Britain, flowers in July, and ripens its seed in September. It is cultivated in Essex, and the west of England, for raising the nap upon woollen cloths, by means of the crooked awns or chaffs upon the heads; which in the wild sort are said to be less hooked. For this purpose they are fixed round the circumference of a cylinder, which is made to turn round, and the cloth is held against them.

5340. There are no varieties of the cultivated teasle, but the wild species is not materially different from it, and may be used in its stead, though its chaff is not quite so rigid.



5341. *The soils on which the teazle grows strongest, are deep, loamy clays, not over rich. The situation should be rather elevated, airy and exposed to the south. In a rotation it may occupy the place of a green and corn crop, as the first year the plants are treated like turnips, and the second the crop is ripened. The soil should be ploughed deep, and well comminuted by cross ploughings, or stirrings with pronged implements, as the cultivator.*

5342. *The sowing season is the beginning of April: the quantity of seed is from one to two pecks per acre, and in quality it should be fresh and plump. The mode of sowing is almost always broad-cast, but no crop is better adapted for being grown in drills, as the plants require hoeing and thinning. The drills may be either sown on ridgelets or a flat surface, in the manner of turnips, or by ribbing. The distance between the rows may be from eighteen inches to two feet. In Essex, carraway is commonly sown with the teazle crop; but this is reckoned a bad plan.*

5343. *The after-culture of this crop consists the first year in hoeing and stirring the soil, and in thinning out the plants to the distance of one foot every way, if sown broad-cast, or to the distance of six inches if sown in rows. Vacancies may be filled up by transplanting; and a separate plantation may be made with the thinnings, but these never attain the same vigor as the seedlings. The culture the second year consists also of hoeing, stirring, and weeding, till the plants begin to shoot. When the teazle is grown broad-cast, the intervals between the plants are dug by means of spades which have long narrow blades, not more than about four inches in breadth, having the length of sixteen or eighteen inches. With these the land is usually worked over in the intervals of the plants three or four times during the summer months; and in the course of the following winter, as about the latter end of February, the land between the plants is to be again worked over by the narrow spades, care being taken that none of the mould falls into the hearts of the plants. And again about the middle of May, when they begin to spindle, another digging over is given, the earth being raised round the root-stems of the plants, in order to support and prevent them from being blown down by the wind. Some cultivators perform more frequent diggings, that the ground may be rendered cleaner and more mellow; consequently the growth of the plants will be the more effectually promoted. This business, in Essex, has usually the name of spaddling, and is executed with great despatch by laborers that are accustomed to perform it.*

5344. *The taking of the teazle crop, when no regard is had for seed, commences about the middle of July, when the blossoms begin to fall from the top, or terminating heads of flowers. It is the best method to have the heads cut as they become ripe; but the work is mostly executed at three different times, at the distances of about ten days or a fortnight from each other. It is performed by means of a knife, contrived for the purpose, with a short blade and a string attached to the haft. This last is done in order that it may be hung over the hand. A pair of strong gloves is likewise necessary. Thus prepared, the laborer cuts off the ripe heads along the rows or lines with about nine inches of stem, and ties them up in handfuls with the stem of one that is more perfectly ripened. And on the evening of the day on which they are cut, they should be put into a dry shed; and when the weather is fine and the air clear, they should be taken out and exposed to the sun daily till they become perfectly dry. Much care must, however, be taken that no rain falls upon them. In doing this, some make use of long small stakes or poles, on which these handfuls are hung during the time of their preparation.*

5345. *As soon as they are completely dried, they should be laid up in a dry room, in a close manner, till they are become tough and of a bright color, and ready for use. They should then be sorted or separated into three different kinds, by opening each of the small bundles. These are distinguished into kings, middlings, and scrubs, according to their different qualities. They are afterwards, the author of *The Somerset Report* says, made into packs, which, of the first sort, contain nine thousand heads, but when of the second twenty thousand; the third is a sort of very inferior value. By some, before forming them into packs, they are done up into what are termed staves, by means of split sticks, when they are ready for sale.*

5346. *The produce of teazle varies from ten to fifteen packs on the acre; nine packs of kings, nineteen of middlings, and two of scrubs, are reckoned a large crop, with a great bulk of haulm. Often, however, the crop fails.*

5347. *The use of the heads of the teazle has been already mentioned. The haulm is of no use but for burning as manure. Parkinson observes, that this is a sort of crop that may be grown to advantage on many lands; in a rotation as a fallow to prepare for wheat, and by burning the straw and refuse stuff after the crop is reaped, it will be found not to impoverish, but rather improve the land. In their young state, the teazle plants stand the winter without danger; and are a good crop for clearing land of all weeds, from their lateness in the process of hoeing, there being few weeds that vegetate at so advanced a season: on all these accounts they become an advantageous crop for the farmer.*

5348. *To save seed, leave a few of the very best plants uncropped, and then when the seed is ripe cut off only the largest and terminating heads, from which the seed is easily separated by beating with flails, and cleaned by the winnowing machine, or a sieve.*

590



5349. *The chief injuries to which the teazle is liable are those effected by the fly and slug in its infant state.*

SUBJECT. 4. *Madder.* — *Rubia tinctorum*, L. *Tetran. Monog. L.* and *Rubiaceæ*, J. *Garance*, Fr.; *Fürberrüthe*, Ger.; *Rubia*, Span.; and *Robia*, Ital. (*fig. 591.*)

5350. *The dyer's madder has a perennial root, and an annual stalk. The root is composed of many long, thick, succulent fibres, almost as large as a man's little finger; these are joined at the top in a head, like the roots of asparagus, and strike very deep into the ground, being sometimes more than three feet in length. From the upper part (or head of the root) come out many side roots, which extend just under the surface of the ground to a great distance, whereby it propagates very fast; for these send up a great number of shoots, which, if carefully taken off in the spring soon after they are above ground, become so many plants. It is a native of the south of Europe, flowers in June, and seeds soon afterwards; but by them it is never propagated. Madder is mentioned by the Greeks as a medical plant, but when it was first used in dyeing is uncertain. It has been cultivated in Holland and Flanders, and other parts of the continent for that purpose for many centuries, and has been tried in this country, but unless the importation of the root from the continent were entirely prevented, it will not answer. Its culture has been attempted at different times when our commerce with the Dutch was interrupted, or when they raised the price of the article exorbitantly high. At present it may be imported not only from Holland, but from France, Italy, and Turkey.*



5351. *The soils most suited to the cultivation of madder, are those of the deep fertile sandy loams that are not retentive of moisture, and which have a considerable portion of vegetable matter in their composition. It may also be grown on the more light descriptions of soil that have sufficient depth, and which are in a proper state of fertility.*

5352. *The preparation of the soil may either consist in trench-ploughings, lengthways and across, with pronged stirrings, so as to bring it to a fine tilth; or, what will often be found preferable, by one trenching two feet deep by manual labor.*

5353. *The sets or plants are best obtained from the runners, or surface-roots of the old plants. These being taken up, are to be cut into lengths of from six to twelve inches, according to the scarcity or abundance of runners. Sets of one inch will grow if they have an eye or bud, and some fibres, but their progress will be injuriously slow for want of maternal nourishment. Sets may also be procured by sowing the seeds in fine light earth a year before they are wanted, and then transplanting them; or sets of an inch may be planted one year in a garden, and then removed to the field plantation.*

5354. *The season of planting is commonly May or June, and the manner is generally in rows nine or ten inches asunder, and five or six inches apart in the rows. Some plant promiscuously in beds with intervals between, out of which earth is thrown in the lazy-bed manner of growing potatoes; but this is unnecessary, as it is not the surface, but the descending roots which are used by the dyer.*

5355. *The operation of planting is generally done by the dibber, but some ley-plant them by the aid of the plough. By this mode the ground is ploughed over with a shallow furrow, and in the course of the operation the sets are deposited in each furrow, leaning on and pressed against the furrow-slice. This, however, is a bad mode, as there is no opportunity of firming the plants at the roots, and as some of the sets are apt to be buried, and others not sufficiently covered.*

5356. *The after-culture consists in hoeing and weeding with pronged hoes, either of the horse or hand kind. Some earth up, but this is unnecessary, and even injurious, as tearing the surface-roots.*

5357. *The madder-crop is taken at the end of the third autumn after planting, and generally in the month of October. By far the best mode is that of trenching over the ground, which not only clears it effectually, but fits it at once for another crop. But where madder has been grown on land prepared by the plough, that implement may be used in removing it. Previously to trenching, the hulum may be removed with an old scythe, and carted to the farmery to be used as litter to spread in the straw-yards.*

5358. *Drying the roots is the next process, which, in very fine seasons, may sometimes be effected on the soil, by simply laying the plants on it as they are taken up; but in most seasons they require to be dried on a kiln, like that used for malt or hops. They are dried till they become brittle, and then packed up in bags for sale to the dyer.*

5359. *The produce from the root of this plant is different according to the difference of the soil, but mostly from ten to fifteen or twenty hundred weight where they are suitable to its cultivation.*

5360. *In judging of the quality of madder-roots, the best is that which, on being broken in two, has a brightish red or purplish appearance, without any yellow cast being exhibited.*

5361. *The use of madder-roots is chiefly in dyeing and calico-printing. The haulm which accumulates on the surface of the field, in the course of three years, may be carted to the farm-yard, and fermented along with horse-dung. It has the singular property of dyeing the horns of the animals who eat it of a red color.*

5362. *Madder-seed in abundance may be collected from the plants in the September of the second and third years; but it is never so propagated.*

5363. *Madder is sometimes blighted; but in general it has few diseases.*

SUBSECT. 5. *Woad. — Isatis tinctoria, L. Tetrad. Siliq. L. and Cruciferae, J. Pastel, Fr.; Waid, Ger.; Gualda, Span.; and Guade, Ital. (fig. 592.)*

5364. *The common woad is a biennial plant with a fusiform fibrous root, and smooth branchy stem rising from three to five feet in height. It is a native, or naturalised in England, flowers from May to July, and its seeds are ripe from July to September. It has been cultivated in France for an unknown length of time, and was introduced to England in 1582, and grown with success. It is now chiefly cultivated in Lincolnshire, where it is a common practice to take rich flat tracts near rivers, at a high price, for the purpose of growing it for two or four years. Those who engage in this sort of culture, form a sort of colony, and move from place to place as they complete their engagements. It is sometimes, however, grown by stationary farmers. The leaves are the parts of the plant used, and it is considered as a severe crop.*

5365. *There is a variety of woad called the dalmatian, described by Miller, and also a wild sort, but only the common is cultivated in this country.*

5366. *The soil for woad should be deep and perfectly fresh, such as those of the rich, mellow, loamy, and deep vegetable kind. Where this culture is carried to a considerable degree of perfection, as in Lincolnshire, the deep, rich, putrid, alluvial soils on the flat tracts extending upon the borders of the large rivers, are chiefly employed for the growth of this sort of crop; and it has been shown by repeated trials that it answers most perfectly when they are broken up for it immediately from a state of sward.*

5367. *The preparation of the soil, when woad is to be grown on grass land, may either be effected by deep ploughings, with the aid of the winter's frost; cross ploughing and harrowing in spring; by deep ploughing and harrowing in spring; by paring and burning; or by trench ploughing, or spade trenching. The first mode appears the worst, as it is next to impossible to reduce old turf in one year, and, even if this is done, the danger from the grub and wire-worm, is a sufficient argument against it. By ploughing deep in February, and soon afterwards sowing, the plants may germinate before the grub is able to rise to the surface; by trench ploughing, the same purpose will be more effectually obtained; and, best of all, by spade trenching. But a method which is equally effectual with the first, more expeditious, and which has a superiority over it in more completely destroying grubs, insects, and other vermin, which are apt to feed on the plants in their early growth, is that of paring and burning. This is, however, chiefly practised where the sward is rough and abounds with rushes, sedge, and other plants of the coarse kind, but might be had recourse to on others, with benefit.*

5368. *The time of sowing may be extended from February to July. Early sowing, however, is to be preferred, as in that case the plants come up stronger and afford more produce the first season.*

5369. *The mode of sowing is generally broad-cast, but the plant might be most advantageously grown in rows and cultivated with the horse-hoe. The rows may be nine inches or a foot apart, and the seed deposited two inches in depth. The quantity of seed for the broad-cast method is five or six pounds to the acre; for the drill mode, two pounds are more than sufficient, the seed being smaller than that of the turnip. New seed, where it can be procured, should always be sown in preference to such as has been kept for some time; but when of the latter kind, it should be steeped for some time before it is put into the ground.*



5370. *The after-culture of the woad consists in hoeing, thinning, prong-stirring, and weeding, which operations may be practised by hand or horse tools, as in the culture of teazel.*

5371. *In respect to the business of gathering the crops with the spring-sown ones, the leaves will generally be ready to be gathered towards the latter end of June or beginning of July, according to the nature of the soil, season, and climate; but for those put in at a later period in the summer, they are often fit to be gathered earlier. This business should, however, constantly be executed as soon as the leaves are fully grown, while they retain their perfect green color and are highly succulent, as when they are left remain till they begin to turn pale, much of their goodness is said to be expended, and they become less in quantity, and of an inferior quality for the purposes of the dyer. In the execution of this sort of business, a number of baskets are usually provided in proportion to the extent of the crop, into which the leaves are thrown as they are taken from the plants, which is effected by the hand, by grasping them firmly and giving them a sort of a sudden twist. In favorable seasons, where the soils are rich, the plants will often rise to the height of eight or ten inches; but in other circumstances they seldom attain more than four or five; and where the lands are well managed in the culture of the plants, they will often afford two or three gatherings, but the best cultivators seldom take more than two, which are sometimes mixed together in the manufacturing of them. It is necessary, that the after croppings, when they are taken, are constantly kept separate from the others, as they would injure the whole if blended together, and considerably diminish the value of the produce. It is said that the best method, where a third cropping is either wholly or partially made, is to keep it separate, forming it into an inferior kind of woad.*

5372. *The produce is mostly from about a ton to a ton and a half of green leaves. The price varies considerably; but for woad of the prime quality, it is often from twenty-five to thirty pounds the ton, and for that of an inferior quality six or seven, and sometimes much more.*

5373. *To prepare it for the dyer, it is bruised by machinery to press the watery part; it is afterwards formed into balls and fermented, re-ground, and fermented in vats, where it is evaporated into cakes in the manner of indigo. The haulm is burned for manure or spread over the straw-yard, to be fermented along with straw-dung.*

5374. *The use of woad in dyeing, is as a basis for the black and other colors.*

5375. *To save seed, leave some of the plants undenuded of their leaves the second year, and when it is ripe in July or August, treat it like turnip-seed.*

5376. *The only diseases to which the woad is liable, are the mildew and rust; when young it is often attacked by the fly, and obliged to be re-sown, and this even on winter-ploughed grass lands more than once.*

SUBSECT. 6. *Weld or Dyer's Weed. — Reseda luteola, L. Dodec. Trig. L. and Cappari-dea, J. Gaude, Fr.; Waud, Ger. (fig. 593.)*

5377. *Weld is an imperfect biennial, with small fusiform roots, and a leafy stem from one to three feet in height. It is a native of Britain, flowers in June and July, and ripens its seeds in August and September. It is cultivated in a few places in England, and chiefly in Essex, for its spike of flowers and sometimes also for its leaves, both of which are used in dyeing. Its culture may be considered the same as that of woad, only being a smaller plant it is not thinned out to so great a distance. It has this advantage for the farmer over all other coloring plants, that it only requires to be taken up and dried, when it is fit for the dyer. It is, however, an exhausting crop.*

5378. *Weld will grow on any soil, but fertile loams produce the best crops. In Essex, it is grown on a stiff loam, moderately moist. The soil being brought to a fine tilth, the seed is sown in April or the beginning of May, generally broad-cast. The quantity of seed is from two quarts to a gallon per acre, and it should either be fresh, or if two or three years old, steeped a few days in water previously to being sown. Being a biennial, and no advantage obtained from it the first year, it is sometimes sown with corn crops in the manner of clover, which, when the soil is in a very rich state, may answer, provided also that hoeing, weeding, and stirring take place as soon the corn crop is cut. The best crops, however, will obviously be the result of drilling and cultivating the crop alone. The drills may be a foot asunder, and the plants thinned to six inches in the row. In the broad-cast mode, it is usual to thin them to six or eight inches distance every way: often when weld succeeds corn crops, it is never either thinned, wed, or hoed, but left to itself till the plants are in full blossom.*

5379. *The crop is taken by pulling up the entire plant, and the proper period for this purpose is when the bloom has been produced the whole length of the stems, and the plants are just beginning to turn of a light or yellowish color; as in the beginning or middle of July in the second year. The plants are usually from one to two feet and a half in height. It is thought by some advantageous to pull it rather early, without waiting for the ripening of the seeds, as by this means there will not only be the greatest proportion of dye, but the land will be left at liberty for the reception of a crop of wheat or turnips; but in this case, a small part must be left solely for the purpose of seed. In the execution of the work the plants are drawn up by the roots in small handfuls, and set up to dry, after each handful has been tied up*



by one of the stalks, in the number of four together in an erect position against each other. Sometimes they, however, become sufficiently dry by turning without being set up. After they have remained till fully dry, which is mostly effected in the course of a week or two, they are bound up into larger bundles, that contain each sixty handfuls, and which are of the weight of fifty-six pounds each: sixty of these bundles constituting a load. These last, in places where this kind of crop is much grown, are tied up by a string made for the purpose, and sold under the title of weld cord.

5380. *The produce of weld* depends much on the nature of the season; but from half a load to a load and a half is the quantity most commonly afforded, which is usually sold to the dyers at from five or six to ten or twelve pounds the load, and sometimes considerably more. It is mostly bought by persons who afterwards dispose of it to the dyers occasionally, as they find it convenient. The demand for it is sometimes very little, while at others it is so great as to raise the price to a high degree. It is sometimes gathered green and treated like woad or indigo; but in general the dried herb is used by the dyers in a state of decoction.

5381. *The use of weld in dyeing* is for giving a yellow color to cotton, woollen, mohair, silk, and linen. Blue cloths are dipped in a decoction of it, which renders them green; and the yellow color of the paint, called Dutch pink, is obtained from weld.

5382. *To save seed*, select a few of the largest and healthiest plants, and leave them to ripen. The seed is easily separated.

5383. The chief disease of weld is the mildew, to which it is very liable when young, and this is one reason that it is often sown with other crops.

SUBJECT. 7. *The Bastard Saffron.* — *Carthamus tinctorius*, L. *Syngen. Polyg. Æqual.* L. and *Cynarocephala*, J. *Carthame*, Fr.; *Wilder Safran*, Ger. (fig. 170.)

5384. *The bastard saffron* is an annual plant, which rises with a stiff ligneous stalk, two feet and a half or three feet high, dividing upwards into many branches, with ovate pointed sessile leaves. The flowers grow single at the extremity of each branch; the heads are large, enclosed in a scaly calyx; each scale is broad at the base, flat, and formed like a leaf of the plant, terminating in a sharp spine. The lower part of the calyx spreads open, but the scales above closely embrace the florets, which stand out near an inch above the calyx; these are of a fine saffron color, and this is the part which is gathered for the use of the dyer.

5385. *It grows naturally in Egypt* and some of the warm parts of Asia, but being an annual our summers admit of its going through a course of existence in this country. Sown in April, it flowers in July and August, and the seeds ripen in autumn; but if the season proves cold and moist, when the plants are in flower, there will be no good seeds produced; so that there are few seasons wherein the seeds of this plant come to perfection in England.

5386. *It is cultivated in great plenty in Germany*, and was formerly grown in England. In *Houghton's Collections*, it is related by a gentleman, in 1683, that twenty-five acres in the vale of Evesham, in Gloucestershire, was sowed with this seed; the soil a mixed sand of about fifteen shillings an acre value; it bore a crop of wheat the year before, was dressed for barley, and had a harrowing extraordinary. This piece of ground was taken for two years by an adventurer in this seed, at the rate of twenty-five pounds per acre, in consideration that this plant is said to be a great impoverisher of land. He sold the flowers in London for 10*l.* per pound; a price, he said, much below his expectation. He gained above thirty shillings an acre clear profit, excepting the price of the seed; but of this there was a plentiful return (about one hundred and forty bushels) which, had it been well managed, would have amounted to a considerable value. Like most other manufacturing plants it is considered an impoverisher of the ground; both by exhausting it, and by affording but little haulm as manure.

5387. *The soil it requires is light*, and the preparation and culture, according to Von Thaer, equal to that of the garden. The seed is sown in rows, or deposited in patches, two feet apart every way, and when the plants come up, they are thinned out, so as to leave only two or three together. The soil is stirred and wed during summer. In August the flowers begin to expand: the petals of the florets are then to be cut off with a blunt knife and dried in the shade, or on a kiln, like the true saffron. This operation is made in the early part of the day, and continued daily till October. The plants are then pulled up, sheaved and shocked, and threshed for their seed.

5388. *The use of the flower of bastard saffron* is chiefly in dyeing. It is also put in soups, pies, and puddings, like the leaves of the marigold or the common saffron. The oil produced from the seed is used both in medicine and painting. The stalks of the plant are commonly burnt as manure.

SUBJECT. 8. *Of various Plants which have been proposed as substitutes for the Thread, and dyeing Plants grown in Britain.*

5389. *Though few of these are likely to come into cultivation*, yet it may be useful to notice them with a view of indicating our resources for extraordinary occasions; leading the young cultivator to reflect on the richness of that immense store-house, the vegetable kingdom; and pointing out sources of experiment and research for the amateur agriculturist. Every kind of limitation has a tendency to degrade the mind, and lessen enterprise. The plants to be here enumerated, naturally arrange themselves as thread plants and coloring plants.

5390. *The thread plants* that have been tried are the *asclepias syriaca*, *urtica dioica*,

(or nettle), the spartium junceum, and scoparium (brooms), epilobium angustifolium, eriophorum polystachion, &c. The asclepias syriaca, Syrian swallow-wort, or Virginian silk, is a creeping-rooted perennial, with strong erect stems from four to six feet high. It is a native of Virginia, and flowers in July. The flowers are succeeded by pods, containing a down or cotton, which the poor people in Virginia collect and fill their beds with. In Germany, and especially at Leignitz, attempts were made, in 1790 and 1800, Von Thaer informs us, to cultivate the plant as a substitute for cotton: the plant was found to grow readily on a poor soil, but the growers could not undersell the importers, nor produce so good an article. The eriophorum polystachion, or cotton grass, grows abundantly in our bogs, and its seeds are furnished with a cottony substance, gathered by the country people to stuff pillows, &c. This substance has been spun and wove into very good cloth. The common nettle affords a fibre which has also been spun and manufactured. The fibre of the spartium junceum, rush-like, or Spanish broom, a native of the south of Europe, but quite hardy in Britain, is made into very good cloth both in the south of France and in Spain. The fibre of the common broom makes an inferior description of cordage in the former country. The epilobium angustifolium, and other species of willow herb, common by the sides of brooks, affords a very good fibre, as do a great variety of plants: and in Sweden a strong cloth is made from the stems of the wild hop (*Humulus lupulus*), and the same thing has been done in England. (*Trans. Soc. Arts.* 1791.) It might be worth the attention of any one who had leisure to collect a few, say only two stalks, of a great number of species from a botanic garden, to immerse them a sufficient time in soft soap and warm water, and prove their absolute and comparative value as fibre plants.

5391. *Of coloring plants*, the number that may be, and even are employed, is almost endless. The reader has only to look into any botanical catalogue, and observe the number of plants whose specific name is formed from the adjective tinctorius; and still these, though numerous, are only a small part. On looking into *The Flora Britannica*, or *Flora Suecia*, he will there find a number of plants, trees, and even mosses and ferns used for dyeing. A number have been tried in this country and given up; as an instance we mention gallium verum, tried in 1789, (when the price of madder was high,) under the authority of the privy council for trade.

#### SECT. II. *Plants cultivated for the Brewery and Distillery.*

5392. *Of plants grown expressly for their use in the brewery*, the only one of consequence is the hop; the anise and carraway are grown on a very limited scale for the distillery.

SUBJECT. 1. *The Hop.* — *Humulus lupulus*, L. *Diac. Pentan.* L. and *Urticææ*, J. *Houblon*, Fr.; *Hoppen*, Ger.; *Lupulo*, Span.; and *Lupolo*, Ital. (*fig.* 594.)

5393. *The hop* is a perennial rooted plant, with an annual twining stem, which on poles or in hedges will reach the height of from twelve to twenty feet or more. It is a native of Britain, and most parts of Europe in hedges, flowering in June, and ripening its seeds in September. The female blossom is the part used: and as the male and female flowers are on different plants, the female only is cultivated. When the hop was first used for preserving beer, or cultivated for that purpose, is unknown; but its culture was introduced to this country from Flanders in the reign of Henry VIII. Walter Blith, in his *English Improver Improved*, 1649, the 3d ed., 1653, p. 240, has a chapter upon improvement by plantations of hops, &c. He observes that "hops were then grown to be a national commodity: but that it was not many years since the famous city of London petitioned the parliament of England against two anuancies, and these were Newcastle coals, in regard to their stench, &c., and hops, in regard they would spoyle the taste of drink, and endanger the people; and had the parliament been no wiser than they, we had been in a measure pined, and in a great measure starved, which is just answerable to the principles of those men who cry down all devices or ingenious discoveries, as projects, and thereby stifle and choak improvements."



5394. *The hop* has long been cultivated extensively in many parts of England, but not much in Scotland or Ireland. According to Brown, hops are not advantageous in an

agricultural point of view ; because much manure is abstracted by them, while little or none is returned. They are an uncertain article of growth, often yielding large profits to the cultivator, and as often making an imperfect return, barely sufficient to defray the expenses of labor. In fact, hops are exposed to many more diseases than any other plant with which we are acquainted ; and the trade affords a greater room for speculation, than any other exercise within the British dominions. (*Brown.*)

5395. There are *several varieties* of the hop. The writer of *The Synopsis of Husbandry* distinguishes them under the titles of the Flemish, the Canterbury, the Goldings, the Farnham, &c. and says, that the Flemish is held in the lowest estimation of any. It is, says he, of a smaller size, of a much closer texture, and of a darker green color than any of the rest, and grows on a red bind ; and has so near an affinity to the wild or hedge-hop, that it would never answer for cultivation, did it not possess the property of resisting the blast with greater vigor than the other kinds ; so that, in years when these last are covered with flies and lice, the Flemish hop appears strong and healthy. At picking time, likewise, this kind of hop, he says, takes less damage, either by the sun or rains, than any other ; and upon these accounts, it may answer the views of the planter to have a few acres of it, which will secure him a crop in a blasting season, when those of the more valuable class are destroyed, so as to be worth nothing.

5396. *The soils most favorable to the growth of hops* are clays and strong deep loams ; but it is also of great importance that the subsoil should be dry and friable, a cold, wet, tenacious, clayey understratum, being found extremely injurious to the roots of the plants ; as, when they penetrate below the good soil, they soon become unproductive, and ultimately decay. Bannister says, that a chalky soil is, of all others, the most inimical to the growth of this vegetable ; the reason of which he takes to arise from the dry and parching quality of the chalk, by which the roots are prevented from absorbing a quantity of moisture, equal to the supply of the vine or bind with sap during its growth ; for though a dripping summer is by no means kindly to the welfare of the hop, yet since the vine in a healthy state is very luxuriant, and furnished with a large abundance of branches, leaves, fruit, &c. it follows that the demand of moisture from the soil must be proportionably great to preserve the plant in health and vigor ; and for this reason the ground ought not to be deficient in natural humidity. Hence we generally find the most luxuriant vine growing on such land as is deep and rich, as moulds, &c. ; and in these grounds it is common, he says, to grow a load on an acre. But it is to be observed, however, that the abundance of fruit is not always in proportion to the length of the vines ; since those soils, which from their fertility cause a large growth of vine, are more frequently attacked with the blast than land of a shallower staple, where the vine is weaker and less luxuriant.

5397. But though *rich moulds generally produce a larger growth of hops than other soils*, there is one exception to this rule, where the growth is frequently eighteen or twenty hundred per acre. This is on the rocks in the neighborhood of Maidstone, in Kent, a kind of slaty ground, with an understratum of stone. On these rocks there is a large extent of hop-garden, where the vines run up to the tops of the longest poles, and the increase is equal to that on the most fertile soil of any kind.

5398. *The most desirable situation for a hop plantation* is ground sloping gently towards the south or south-west, and screened by means of high grounds or forest-trees, from the north and north-east. At the same time it ought not to be so confined as to prevent that free circulation of air which is indispensably necessary where plants grow so close together, and to such a height. A free circulation of air, in a hop-ground, not only conduces to the health and vigor of the plants, but also prevents the crops from being blighted, or what the hop-farmers call fire-blasted, which often happens towards the middle of a large close planted hop ground ; while the out-sides, in consequence of the more free circulation of air that there takes place, receive no injury whatever.

5399. Bannister asserts, that those fields that lie within a few miles of the sea, or in the neighborhood of marshy or fenny levels, are seldom favorable to the growth of hops, as such grounds generally miscarry in a blasting year ; and though, from the fertility of the soil, they may perhaps bring a plentiful crop in those seasons when the growth is general, such situation is by no means an eligible spot for a hop ground. In Worcestershire and Herefordshire hops are very generally grown between the rows of fruit trees in dug or ploughed orchards.

5400. *In preparing the soil* previously to planting, considerable attention is necessary by fallowing, or otherwise, to destroy the weeds, and to reduce the soil to as pulverised a state as possible. The ridges should also be made level, and dung applied with a liberal hand. The most effectual preparation is trenching either by the plough or by manual labor.

5401. *The motle of planting* is generally in rows, making the hills six feet distant from each other ; though there are some people who, from avaricious motives, prefer a five-foot plant. But as this vegetable, when advanced in growth, produces a large redundancy of bind or vine, and leaves, it should seem that six feet cannot be too wide a distance ; and that those which are planted closer will, from too confined a situation, be prevented from enjoying a free circulation of the air ; from which much injury may proceed, as blasts, mildews, mould, and other accidents, not to mention the disposition of the vine to house or grow together at the tops of the poles, whereby the hops are so overshadowed as to be debarred the influence of the sun, and thus not arrive to half their growth.

5402. *As the planters differ in their number of hills* to be made on the same given quantity of land, so are they no less capricious as to the manner of placing them ; some choosing to set them out with the most cautious regularity in rows of equal distances, whilst others prefer a triangular plant. The former method has this advantage over the other ; that the intervals may, in the early part of the summer, be kept clean by means of the cultivator and harrow, from which the latter is excluded by their irregular station ; and thus the ground must be tilled by the hoe at a great increase of charge, as the same labor

might be performed to as much advantage with one horse, a man, and a boy, who will do more work in a day than half a dozen laborers can with a hoe.

5403. The ordinary season for planting is spring, in February or March; but if bedded plants, or such as have been nursed for one summer in a garden are used, then by planting in autumn some produce may be had the succeeding year. But, according to the author of *The New Farmer's Calendar*, "the time for planting is commonly that of dressing and pruning the old vines when cuttings may be had, which is in March or April; but when root-sets are used, as on the occasion of grubbing up an old plantation, October to the beginning of November. But at whatever period they are planted, great care should be taken that the same sorts be planted together, as by this means there are advantages derived in their after-culture."

5404. *The plants or cuttings are procured* from the old stools; each should have two joints or eyes; from the one which is placed in the ground, springs the root; and from the other the stalk, provincially the bind; they should be made from the most healthy and strong binds, each being cut to the length of five or six inches. Those to be nursed are planted in rows a foot apart, and six inches asunder in a garden; and the others at once where they are to remain.

5405. *The mode of performing the operation* of planting in Kent is as follows: the land having been previously cleaned and prepared, dung is laid on the field in small heaps near the places where it is proposed to plant the hop slips or sets. These places are commonly marked off, by placing a number of stakes at proper and regular distances; that done, small pits are formed by taking out a spit or spade depth of earth; and the earth below being gently loosed, a certain quantity, about half a bushel, of dung is laid thereon; then the earth that was formerly taken out is again replaced, and so much added as to form a small hillock. On this hillock, five, six, or seven sets, procured from the roots or shoots of the old stock, are dibbled in. The plants are placed in a circular form towards the top of the hillock, and at the distance of five or six inches from each other. They are made to incline towards the centre of the hillock, where another plant is commonly placed.

5406. *Another mode of planting* is as follows: strike furrows with the plough equally distant, eight feet asunder; when finished, repeat the same across in the opposite direction, which will divide the piece into eight-foot squares. The hills are to be made where the furrows cross each other, and the horse-hoe may be admitted between the rows both ways. According to the Suffolk husbandry, the plantations are formed into beds sixteen feet wide, by digging trenches about three feet wide, and two or three feet deep; the earth that comes out being spread upon the beds, and the whole dug and levelled. Upon this they, in March, form the holes six feet asunder every way, twelve inches diameter, and a spit deep, by which three rows are formed on each bed. Into each hole they put about half a peck of very rotten dung, or rich compost; scatter earth upon it, and plant sets in each, drawing earth enough to them afterwards to form something of a hillock.

5407. *An interval crop* is generally taken the first summer of a hop plantation. Beans are very generally grown, and Bannister is of opinion that two rows of beans may be planted in each interval without any damage to the hops, whether bedded sets or cuttings. In the latter case, this method may be pursued the second year, at the end of which the vine from the cuttings will not be in a forwarder state than that from the bedded sets in the first autumn after planting. Others, however, think that neither beans, cabbages, or any other plants, except onions, should be put in.

5408. *The after-culture of the hop*, besides the usual processes of hoeing, weeding, stirring, and manuring, includes earthing-up, staking, and winter dressing.

5409. *Hoeing* in hop plantations may always be performed by a horse implement, and one in use for this purpose in the hop counties, is known by the name of hop-nidget, and of which the expanding horse-hoe (fig. 308.) is an improvement; when the hop-stools are formed in the angles of squares, the intervals may be hoed both lengthways and across, and nothing is thus left to be performed by manual labor but pulling out any weeds which may rise in the hills.

5410. *Stirring*, in the hop districts, is chiefly performed in winter by a three-pronged fork (provincially spud), but it might be equally well effected then or at any season of the year by the common plough, and the expanding horse hoe, set with coulters or prongs. With the use of the latter implement the soil might be stirred to any desirable depth, either in summer or winter; and by the use of the plough, the surface could be changed at discretion. Once going and returning would effect this, either by the paring or clearing out; that is, forming either a ridglet, or gutter between the rows, both lengthways and across. Twice or thrice going in the same direction would also succeed, and would be the preferable mode of covering in manure.

5411. *In the application of manure*, various modes are adopted. Some always use well rotten stable dung; others composts of earth and dung; and a few, littery dung. In laying it on, many prefer the autumn to the spring, and heap it on the hills without putting any between the rows. Others put it all between the rows, alleging that laying it on the hills encourages insects, exposes the dung to evaporation and loss, and sometimes, when mixed with earth, hinders the plants from coming up. A great deal will be found in favor and against each of these modes, in the numerous works on the culture of the hop, which have been written during three centuries; but it must be obvious to any person generally conversant with vegetable culture, that well-rotted stable dung must be the best kind for use; and early in spring the best season for laying it on; that little benefit can be derived by the roots when it is laid on the hills, and consequently



that it ought to be turned into the soil between the rows by the plough. Fifty cart loads of dung and earth, or thirty of dung, once in three years, is reckoned a good dressing; but some give ten or twelve loads every year. Too much dung renders the hops what are called mouldy, and with too little the crop will be poor and more liable to be eaten by insects.

5412. *Earthing-up* commences the first May after planting, whether that operation be performed in spring or autumn. By the end of that season, the young shoots have made some progress, and the earth is then drawn up to their roots from the surrounding intervals, in order to strengthen them. The next earthing-up is in autumn, when the hills are by some covered with compost or manure; but by such as prefer ploughing in the manure between the rows, this earthing-up does not take place. Some give an earthing-up of this kind in spring, and generally in February, chiefly to retard the plants, as that is found to render them less liable to disease, and the attacks of insects: for the shoots not beginning to grow till the weather is warm, they then shoot the more rapidly. In April and May, their progress is slow; but in June and July, when the nights are warm, they will grow nearly an inch in the hour. The only essential earthings up, however, are those given the first year in May, and those given annually whether in autumn or spring, and which indeed may be called replacings of earth, rather than earthing-up; after the operation of dressing, to be next described.

5413. *In dressing the hop plants*, the operations of the first year are confined to twisting and removing the haulm, to which some add cuping or earthing-up in autumn. The operation of twisting, is confined to such plants as have been planted in spring, and are not expected to produce any crop that season. It is performed in the end of June or in July, and consists in twisting the young vines into a bunch or knot; so that by thus discouraging their growth, the roots are enabled to spread out more vigorously, and to acquire strength previous to the approach of the winter season.

5414. *Removing the haulm* takes place soon after Michaelmas, and consists simply in cutting it over with a sickle, and carrying it off the field for litter, or burning. After this operation, some add cuping, or covering the hill with a compost, but this does not appear necessary, and is in many cases left undone.

5415. *The first year's dressing* of hops expected to produce flowers, such as those planted from bedded sets the preceding autumn, consists in supplying three or four half poles, that is, poles of four or five feet in length to each hill, and on removing the haulm in autumn, as in the other case.

5416. *The yearly dressing of established hop plantations* consists of what is provincially called picking. This operation is generally commenced on the return of good weather, in March, when the hills are spread out, in order to give opportunity to prune and dress the stocks. The earth being then cleared away from the principal roots by an iron instrument called a picker, the remains of the former year's vines are cut off, together with the shoots which were not allowed to attach themselves to the poles the former season, and also any young suckers that may have sprung up about the edges of the hills; so that nothing is allowed to remain that is likely to injure the principal roots, or impede their shooting out strong vigorous vines at the proper season. After the roots are properly cleaned and pruned, the hills are again formed, with an addition, if not every year, at least every second or third year, of a proper quantity of compost manure, that had been previously laid in small heaps on the hop-ground in the course of the winter, or in the early part of spring. At this season such sets are procured as may be wanted for the nursery, or for new plantations.

5417. *The yearly operation of stacking or setting the poles*, commences towards the end of April, or at whatever period, earlier or later, the shoots have risen two or three inches. The poles are straight slender shoots of underwood, ash, oak, chestnut, or willow, from sixteen to twenty feet high. These poles are set two, but more frequently three, to a hill: they are so placed as to leave an opening towards the south, to admit the sun-beams. The manner of fixing them is by making deep holes or openings in the ground with an iron crow. Into these holes the root-ends are put, when the earth is rammed so hard about them, that they very seldom alter from the position in which they were placed, except on occasion of very violent gales of wind. Great care is necessary in placing the poles, and no less judgment and experience in determining what ought to be the proper height. When very long poles are set in a hop ground, where the stocks are too old or too young, or where the soil is of indifferent quality, the stocks are not only greatly exhausted, but the crop always turns out unproductive; as, till the vines reach the top, or rather till they overtop the poles, which depends on the strength of the stocks and the quality of the soil, the lateral branches on which the hops grow, never begin to shoot out, or make any progress.

5418. *Planters are much divided in their sentiments as to the number of poles to be set against each hill.* Three poles are the general allowance, observing to place the stoutest pole to the northern aspect of the hill; though it is no uncommon practice to set four poles, and in strong land five or six, to a hill. In behalf of this latter mode it is urged, that, where the land usually produces a great redundancy of vine, it is prudent to set a number of poles answerable to the luxuriance of the shoots. But, if a free circulation of the air be a matter of that importance to the well-being of a crop of hops, as is generally imagined, (and this is a doctrine which it is believed cannot be controverted), the incumbrance of the hills, with an additional number of poles, cannot fail to be of infinite dis-service to the future growth of the hops; and it will be readily acknowledged, that the quantity of hops on the same given number of hills will be more considerable, where three poles only are set up, than when the hills are crowded with a larger number; whether we consider the mischief likely to accrue from the stagnated air, or from the redundancy of the vine, by which the hops are prevented from arriving to their proper size or growth. The chief art in piling a hop-ground is, first, to pitch the hole to a proper depth, about twenty inches: next to set down the pole with some exertion of strength, so that the same being well sharpened may fix

itself firm at the bottom; thirdly, that the tops of the poles may stand in such a direction as to lean outwards from the hill, to prevent, as much as possible, the housing of the vine; and lastly, to tread the earth close to the pole with the foot. For want of regard to these particulars in the laborer, a moderate blast of wind will loosen the poles, so as not only to occasion a double expense, but the hazard of injuring the future crop is very great, by tearing asunder the vine, which, from its great luxuriance, will become twisted together, or, as it is termed, housed at the extreme parts of the poles.

5419. *With respect to the species of woods proper for poles*, it is suggested that they appear to prefer a rough soft bark, to one which is more smooth and polished. An experienced grower particularises the maple, whose bark is peculiarly soft and warm; adding, that he has frequently observed, when the morning has been cold, the sensitive leader of a tender fresh-poled vine reclining its head against the velvet bark of the maple, while others held theirs aloof, from chilly smooth-barked poles. This is probably a general law, or ordinance of nature, to climbing plants; and may be essential to their preservation, showing, in a palpable manner, the perception and strength of vegetable instinct.

5420. And in regard to the *size of the pole*, hops, likewise, it is well known, have their instinctive choice or approbation, with respect to the thickness of their support; embracing, with greater readiness, a pole that is moderately small, than one which is thick at the bottom. The ordinary circumference of poles, at the thickest end, may be set down at six to nine inches, tapering to the size of a walking-cane at the top. And the length from fifteen to twenty feet, or upwards. Different grounds require different lengths of pole. In the rich grounds, in the neighborhood of Maidstone, the poles of grown hops stand, in general, from fourteen to sixteen feet above the hills, and have from eighteen inches to two feet beneath the surface. But, on weaker lands, poles are not seen to rise more than ten to twelve feet high. Hence, a variety of ground is convenient; as the poles, by decaying at the roots, grow shorter, and, in a course of years, get too short for strong vines, on rich land. They are, in this case, sold and transferred to less productive lands, and vines of humbler growth.

5421. *New poles have sometimes the bark shaved off*, under an idea that it saves them from the worm; while some men are of opinion, that there is a warmth in the bark, which is acceptable to the young vines; and although in two or three years the bark drops off, the surface of the wood has, by that time, acquired a degree of softness. Whether a hard, smooth, polished pole, is unfriendly to the hop or not, to peel the poles would evidently be improper, as promoting their decay.

5422. *Short light poles are usually pointed in hand*, without other support. But the tall heavy pole requires something to keep the top steady. This is simply had, by tying together three poles of equal length, two or three feet from their tops; and setting them up in the form of what are called triangles, in use for loading timber on wheel-carriages. The top of the pole to be sharpened, being dropped in between the points or horns of the triangles, receives the required stay; a block being placed in a convenient situation below, to work upon. And this sort of work, whether on new or on old poles, is sometimes done before they are stacked, or set up in piles; sometimes immediately before they are used. But in pointing poles that have been used, the part which stood in the ground the preceding year is struck off, if much tainted, and a fresh point given to the sound part. But, if the bottom part remain firm, it is sharpened again for another season.

5423. *Tying the shoots or vines to the poles* is the last operation in the after or summer culture of the hop. This requires the labor of a number of persons: women are generally employed, who tie them in several different places with withered rushes, but so loosely as not to prevent the vines from advancing in their progress towards the top of the poles. When the vines have got to such a height as to be beyond reaching with the hand, proper persons go round, and, using standing ladders, tie all the vines that appear inclined to stray from the poles.

5424. *The season for this operation* varies from the middle of May to the end of June, and one important part of the operation consists in selecting the shoots. The forwardest vine should always be extirpated, as it is well known that the branches arising from these early shoots will produce little, if any fruit. The second shoots, where the hills are not overloaded with plants, and where the ground is not of a nature to send forth a very luxuriant vine, may with safety be tied up. But where the land is apt to push forward a great redundancy of shoots, where the vine is always strong and vigorous, and where the failure in the crop chiefly arises from this cause, the greatest prudence is necessary, at the season for tying, to make choice of a proper vine; especially in years which may be supposed to be attended with a blast; such as those wherein an easterly wind has prevailed throughout the month of March, whence one may fairly conclude that the same weather will happen during the course on the month of May, which never fails to bring the long-winged fly. In such a season it would be well worth while to eradicate all the vine which first appears, and trust to a latter shoot, so as to protract the tying till the last week in May. This hint was taken from the observations made on the poor and thin lands in such blasting years where the vine is naturally backward, and seldom becomes fit for the tyers till towards the latter end of May, when that on the forward ground will have advanced nearly to the tops of the poles, and to an inattentive observer seems to promise fair for a crop; whereas, to those who have been conversant in these matters, the loss of the crop, though the vine at that time be green and flourishing, may be easily foreseen; whilst on the poorer soils there is generally a saving crop even in years when the blast is most prevalent. These considerations, he says, have suggested the protracting the growth of the vine in the manner above-mentioned, which seems conformable to reason and experience.

5425. *Taking the crop* is a most important operation in the hop economy. Hops are known to be ready for pulling when they acquire a strong scent, and the seeds become firm and of a brown color, which, in ordinary seasons, happens in the first or second week of September. And when the pulling season arrives, the utmost assiduity is requisite on the part of the planter, in order that the different operations may be carried on with regularity and dispatch; as the least neglect, in any department of the business, proves in a great degree ruinous to the most abundant crop, especially in precarious seasons. Gales of wind at that season, by breaking the lateral branches, and bruising the hops, prove nearly as injurious as a long continuance of rainy weather, which never fails to spoil the color of the crop, and thereby render it less saleable.

5426. *As a preparation for pulling the hops*, frames of wood, in number proportioned to the size of the ground, and the pickers to be employed, are placed in that part of the field which, by having been most exposed to the influence of the sun, is soonest ready. These frames, which are called *bins* or *cribs*, are very simple in the construction, being only four pieces of boards nailed to four posts, or legs, and, when finished, are about seven or eight feet long, three feet broad, and about the same height. A man always attends the pickers, whose business it is to cut over the vines near the ground, and to lay the poles on the frames to be picked. Commonly two, but seldom more than three, poles are laid on at a time. Six, seven, or eight pickers, women, girls, and boys, are employed at the same frame, three or four being ranged on each side. These, with the man who sorts the poles, are called a set. The hops, after being carefully separated from the leaves and branches, or stalks, are dropped by the pickers into a large cloth, hung all round within-side the frame on tenter-hooks. When the cloth is full, the hops are emptied into a large sack, which is carried home, and the hops laid on a kiln to be dried. This is always done as soon as possible after they are picked, as they are apt to sustain considerable damage, both in color and flavor, if allowed to remain long in sacks in the green state in which they are pulled. In very warm weather, and when they are pulled in a moist state, they will often heat in five or six hours: for this reason the kilns are kept constantly at work, both night and day, from the commencement to the conclusion of the hopping season.

5427. *To set on a sufficient number of hands*, is a matter of prudence, in the picking season, that the oasts or kilns may never be unsupplied with hops; and if it is found that the hops rise faster than could have been expected, and that there are more gathered in a day than can be conveniently dried off, some of the worst pickers may be discharged; it being very prejudicial for the green hops to continue long in the sacks before they are put on the oast, as they will in a few hours begin to heat, and acquire an unsightly color, which will not be taken off in the drying, especially if the season be very moist; though, in a wet hopping, it is no easy matter to prevent the kilns from being overrun, supposing that there were pickers enough to supply them if the weather had been dry, because in a wet cold time the hops require to lie a considerable while longer on the kiln, in order that the superabundant moisture may be dried up. It is therefore expedient in this case that each measuring be divided into a number of green pockets or pokes. The number of bushels in a poke ought never to exceed eleven; but when the hops are wet, or likely to continue together some time before they go on the kiln, the better way is to put only eight bushels in a sack, pocket, or poke.

5428. *Donaldson* asserts, that diligent hop-pickers, when the crop is tolerably abundant, will pick from eight to ten bushels each in the day, which, when dry, will weigh about one hundred weight; and that it is common to let the picking of hop-grounds by the bushel. The price is extremely variable, depending no less on the goodness of the crop than on the abundance or scarcity of laborers. The greatest part of the hops cultivated in England are picked by people who make a practice of coming annually from the remote parts of Wales for that purpose.

5429. *The operation of drying hops* is not materially different from that of drying malt, and the kilns, or oasts, are of the same construction. The hops are spread on a hair-cloth, and from eight to ten, sometimes twelve, inches deep, according as the season is dry or wet; and depending also on the state of the hops in regard to ripeness. A thorough knowledge of the best method of drying hops can only be acquired by long practice. The general rules are to begin with a slow fire, and to increase it gradually, till, by the heat on the kiln, and the warmth of the hops, it is known to have arrived at a proper height. An even steady fire is then continued for eight or ten hours, according to the state or circumstances of the hops, by which time the ends of the hop-stalks become quite shrivelled and dry, which is the chief sign by which to ascertain that the hops are properly and sufficiently dried. They are then taken off the kiln, and laid in a large room or loft till they become quite cool; and they are now in condition to be put into bags, which is the last operation the planter has to perform previous to sending his crop to be sold.

5430. *When hops are dried on a cockle-oast*, sea-coal is the usual fuel, of which a chaldron is generally esteemed the proper allowance to a load of hops. On the hair kilns, charcoal is commonly used for this purpose. Fifty sacks of charcoal are termed a load, which usually sells for about fifty shillings. The price for burning is three shillings per load, or twelve shillings for each cord of wood. The process of drying having been completed, the hops are to be taken off the kiln, and shovelled into an adjoining chamber called the stowage-room; and in this place they are continually to be laid as they are taken off the kiln, till it may be thought convenient to put them into bags, which is rarely done till they have lain some time in the heap; for the hops, when first taken off the kiln, being very dry, would (if put into the bags at that time) break to pieces, and not draw so good a sample as when they have lain some time in the heap; whereby they acquire a considerable portion of toughness, and an increase of weight.

5431. *The bagging of hops* is thus performed:—in the floor of the room, where the hops are laid to cool, there is a round hole or trap, equal in size to the mouth of a hop bag. After tying a handful of hops in each of the lower corners of a large bag, which serve afterwards for handles, the mouth of the bag is fixed securely to a strong hoop, which is made to rest on the edges of the hole or trap; and the bag itself being then dropped through the trap, the packer goes into it, when a person who attends for the purpose, puts in the hops in small quantities, in order to give the packer an opportunity of packing and trampling them as hard as possible. When the bag is filled, and the hops trampled in so hard as that it will hold no more, it is drawn up, unloosed from the hoop, and the end sewed up, other two handles having been previously formed in the corners in the manner mentioned above. The brightest and finest colored hops are put into pockets or fine bagging, and the brown into coarse or heavy bagging. The former are chiefly used for brewing fine ales, and the latter by the porter brewers. But it is to be observed, that where hops are intended to be kept for any length of time, it is most proper to put them into coarse cloth. The proper length of a bag is two ells and a quarter, and of a pocket nearly the same, being one ell in width. The former, if the hops are good in quality, well cured, and tight trodden, will weigh about two hundred and a half; and the latter, if of the Canterbury pocketing, about one hundred and a half. If the weight either exceeds or falls much short of this medium, it induces a surmise, that the hops are

either in themselves of an inferior quality, or have been injudiciously manufactured in some respect or other.

5432. *The stripping and stacking of the poles* succeeds to the operation of picking. It is of some consequence that this business be executed as soon as possible after the crop is removed; not only that the poles may be much safer from thieves when set up in stacks, but that in such form they may take far less damage by the weather than when dispersed about the ground with the vine on them. The usual price for stripping and stacking is five shillings per acre. At this time, such poles as may be deemed unfit for further service should be flung by, that the planter may have an early knowledge of the number of new poles which will be wanting; and thus the business of bringing on the poles may be completed in the winter time, when the horses are not required about other labor; and these new poles may be drawn from the wood on the ground, and adjusted to the separate stacks, as the state of the different parts of the ground may require, and the whole business be completed before the poling season: whereas, when this method of flinging out the old poles is neglected at the stacking, the planter being ignorant of the number of new poles that will be required for the ensuing year, often finds at the poling season that he has not laid in a sufficient stock.

5433. *In performing the operation of stacking* the poles are set up in somewhat conical piles, or congeries, of two to five hundred each. The method of proceeding is this: three stout poles of equal length are bound together, a few feet from their tops, and their feet spread out, as those already mentioned for pointing the poles. These serve as a stay to the embryo pile; the poles being dropped in on each side, between the points of the first three; cautiously keeping an equal weight on every side; for, on this even balance, the stability of the stack depends. The degree of inclination or slope, and the diameter of the base of the pile, vary with the length and the number of poles set up together. A stack of three or four hundred of the long poles of the environs of Maidstone, occupy a circle of near twenty feet in diameter. It is observable, however, that the feet of the poles do not form one entire ring; but are collected in bundles or distinct divisions, generally from three to six or eight in number; each fasciculus being bound tightly together, a few feet from the ground, with a large rough rope made of twisted vines, to prevent the wind from tearing away the poles; and the openings between the divisions give passage to violent blasts, and tend to prevent the piles from being thrown down in a body; a circumstance which does not often take place in screened grounds. But, on the high exposure of Cox Heath, where great quantities of new poles brought out of the Weald are piled for sale among the Maidstone planters, it is not uncommon for the piles to be blown down, and to crush in their fall the sheep or other animals that may have taken shelter under them. A caution, this, to the inexperienced in the business of stacking; and an apology, if one is wanted, for the minuteness of the detail.

5434. *The operation of stripping* is generally performed by women; being nothing more than tearing off the bind or vines. Many people burn it on the ground. Others suffer it to be carried off by their workmen for firing; and there are some, who tie it up into small bundles, which they bring home and form into a stack, to answer the purpose of bavons in heating their ovens or coppers.

5435. *The produce of the hop crop* is liable to very considerable variation, according to soil and season, from two or three to so much as twenty hundred weight; but from nine to ten, on middling soils, in tolerable seasons, are considered as average crops, and twelve or fourteen good ones. Bannister asserts, that sixty bushels of fresh gathered hops, if fully ripe, and not injured by the fly or other accident, will, when dried and bagged, produce a hundred weight. Where the hops are much eaten by the flea, a disaster which often befalls them, the sample is not only reduced in value, but the weight diminished; so that, when this misfortune occurs, the planter experiences a two-fold loss.

5436. *To judge of the quality of hops*, as the chief virtue resides in the yellow powder contained in them, which is termed the condition, and is of an unctuous and clammy nature, the more or less clammy the sample appears to be, the value will be increased or diminished in the opinion of the buyer. To this may be added the color, which it is of very material consequence for the planter to preserve as bright as possible, since the purchaser will always insist much on this article; though, perhaps, the brightest colored hops are not always the strongest flavored.

5437. *The duration of the hop plantation* on good soil may be from fifteen to thirty years; but in general they begin to decline about the tenth year. Some advise that the plantation should then be destroyed and a fresh one made elsewhere; others consider it the best plan to break up and plant a portion of new ground every two years, letting an equal quantity of the old be destroyed, as in this way a regular succession of good plantation will be kept up at a trifling charge.

5438. *The expenses of forming new hop-plantations* is in general very great, being estimated, in many districts, at from not less than seventy to a hundred pounds the acre. The produce is very uncertain; often very considerable; but some seasons nothing, after all the labor of culture, except picking, has been incurred. Where the lands are of the proper sort for them, and there are hop-poles on the farm, and the farmer has a sufficient capital, it is probably a sort of husbandry that may be had recourse to with advantage; but under the contrary circumstances, hops will seldom answer. In growing them in connection with a farm, regard should be had to the extent that can be manured without detriment to the other tillage lands. On the whole, hops are an expensive and precarious crop, the culture of which should be well considered before it is entered upon.

5439. *The use of the hop in brewing* is well known: their use is to prevent the beer from becoming sour. In domestic economy the young shoots are eaten early in the

spring as asparagus, and are sold under the name of hop-tops; they are said to be diuretic, and to be good against the scurvy, taken in an infusion. The herb will dye wool yellow. From the stalks a strong cloth is made in Sweden: for this purpose they must be gathered in autumn, soaked in water all winter; and in March, after being dried in a stove, they are dressed like flax. They require a longer time to rot than flax; and if not completely macerated, the woody part will not separate, nor the cloth prove white or fine. Hence a farmer who has a hop plantation need neither grow asparagus nor flax, and may, when the flowers fail from disease, separate the fibre from the vine, and employ the poor, or machinery, in spinning and weaving it. A decoction of the roots of hops is considered as good a sudorific as sarsaparilla; and the smell of the flowers is found to be soporific. A pillow filled with hops was prescribed for the use of Geo. III. in his illness of 1787.

5440. *The hop is peculiarly liable to diseases.* There is scarcely any sort of plant cultivated as a field-crop that is more liable to become diseased than the hop. It is apt, in the very early stage of its growth, to be devoured, as it rises above the surface of the ground, by the ravages of an insect of the flea kind. At a more advanced stage, it is subject to the still more injurious effects of the green or long-winged fly, red spider, and otter moth: the former, by the depositing of their ova, afford the means of producing lice in great abundance; by which the plants are often very greatly, if not wholly, destroyed, and the larvæ of the latter prey upon the roots, and thus render the plants weak and subject to disease. The honey-dew is another disease to which the hop is exposed about the same time, and by which it is often much injured. The mould occurs in general at a somewhat later period, being equally injurious. Hop-crops are also exposed to other injuries, as the blight, and fire-blast, but which take place at different times, though mostly towards the latter periods of the growth of the plants.

5441. With regard to *the flea*, which is said to be an insect of the same kind as that which is so prejudicial to the young turnip, it is observed to make the greatest havoc in seasons where the nights are cold and frosty, and the days hot and inclined to be dry; eating off the sweet tender tops of the young plants; and which, though not wholly destroyed, shoot forth afterwards in a far less vigorous manner, and of course become more exposed to diseases. It has been found to commit its depredations most frequently on the plants in grounds that have been dunged the same year; on which account it has been suggested that the manure employed for the purpose of covering the hills should be previously well mixed and incorporated as directed above (5411.); and that it should be applied either over the whole of the land, or only the hills, as soon as possible after the plants have been cut over; but the former practice is probably the best. It makes its greatest depredations in the more early cold spring months, as the latter end of April and beginning of the succeeding month, disappearing as the season becomes more mild and warm. In these cases, the principal remedy is that of having the land in a sufficient state of fertility, to enable the young plants to shoot up with such vigor and rapidity as to become quickly incapable of being fed upon and devoured by the insect. And the frequent stirring of the mould about the roots of the plants by the hoe may be of utility in the same view.

5442. With respect to the *green or long-winged fly*, it mostly makes its appearance about the latter end of May, and in the two succeeding months; being supposed to be produced by the prevalence of north-easterly winds about that period. It is highly destructive to the young leaves of the plants. They are said, under such a state of the wind, to scarcely ever fail covering the leaves; and, by dropping their ova, producing an abundance of lice, by which the crops are often much injured; as when they have once obtained complete possession of the plants, they seldom or ever leave them before they are wholly destroyed. The forwardest and most luxuriant hop-vines are in general the most disposed to be attacked by insects of this sort. Their removal chiefly depends upon a change taking place in the wind more to the south, and the setting-in of more mild, warm, and temperate weather.

5443. It has been found that *the otter moth*, by depositing its eggs upon the roots of the plants, renders them liable to be attacked by the larvæ, and the healthy growth of the hops to be thereby greatly impaired, the crops being of course much injured in their produce. Stirring the earth well about the roots of the plants may probably sometimes be serviceable in cases of this kind.

5444. *The honey-dew* mostly occurs after the crops have been attacked by some of these kinds of insects, and when the weather is close, moist, and foggy. In these cases, a sweet clammy substance is produced upon the leaves of the plants, which has the taste of honey, and they have at first a shining appearance, but afterwards soon become black. It is a disease that mostly happens in the more forward crops; and the chief dependence of the planter for its removal, according to Bannister, is that of heavy thunder showers taking place; as by this means, when the destruction of the hops has not proceeded too far, they are often much restored, the insects that devour the leaves and vines being greatly destroyed, the growth of fresh shoots promoted, and a favorable bloom brought on the plants.

5445. It is well known that *the fen, mould, or mildew*, is a disease to which the hop-crop is exposed at a later period of its growth, and which chiefly attacks the part where the hop is attached to the stem. It is said that its production is greatly promoted by moist damp weather, and a low situation; those hop-crops, that grow on low, close, rich grounds, being the most liable to be attacked by it: and it is found to soon spread itself over the whole crop, after it has once seized upon any part of it. The nature of this vegetable disease has not been yet sufficiently investigated; it has been suggested by Darwin and Willdenow to be a plant of the fungus kind, that is capable of growing without light or change of air, attaching itself to plants already in a morbid condition, and by its roots penetrating their vessels. And on this supposition, the best remedy is believed to be that of thinning the plants, in order to afford a more free circulation of air, and admit the light more extensively; by which the vigor of the hop-plants may be restored, and the disease be of course removed. In this view, it is probable, by planting the hills more thinly, and making them at greater distances from each other, the disease might in some measure be prevented from taking place. (See 1659.)

5446. *Diseases termed blights* are frequently met with in hop-crops, at different periods of the growth of the plants, but mostly in the more early stages of their rising from the hills, while the nights are cold and frosty in the spring months, and the days have much sun and heat; by which the living powers of the plants are greatly exhausted in the day-time by the stimulus of heat, and of course much injured, or wholly destroyed in the nights, from being exposed to a freezing air, which is incapable of exciting the actions, which are necessary for the preservation of vegetable life. As the presence of this disease is

supposed to be greatly connected with the prevalence of winds from the northern or easterly quarters, there is often a flea produced of a similar kind to that which attacks the shoots in their early growth. (5441.) It is highly injurious, by preying upon the nutriment of the blossoms, and thereby diminishing their weight and changing them to a brown color, which is very prejudicial in their sale at the market.

5447. *The fire-blast* is a disease that hop-crops are exposed to, in the later periods of their growth, and generally supposed to proceed from the particular state of the air or weather. It has been conjectured to be the effect of lightning, as it takes place, for the most part, at those seasons when it is the most prevalent, and in a very sudden manner: and besides, the most forward and most luxuriant vines are the most subject to be affected. It has been suggested, that in exposures that are particularly liable to have the crops thus injured, it may be advisable to plant thinner, to keep back the growth of the plants as much as possible, by extirpating all the most forward shoots, and to employ a less proportion of the earthy compost in their culture.

5448. *In respect to the duty on hops*, it is best for the planter to have the acts before him. But every grower of hops in Britain is legally obliged to give notice to the excise, on or before the first day of September, of the number of acres he has in cultivation; the situation and number of his oasts; the place or places of bagging, which, with the store-rooms, or warehouses, in which the packages are intended to be lodged, are entered by the revenue officer. No hops can be removed from the rooms thus entered before they have been weighed and marked by a revenue officer; who marks, or ought to mark, not only the weight, but the name and residence of the grower, upon each package.

SUBJECT. 2. *Of the Culture of the Coriander and Caraway (fig. 595 a, b).*

5449. *The coriander, (Coriandrum sativum, L. fig. 595 a)*, is a small rooted annual, with branchy stems rising from one to one and a half feet in height. It is a native of the south of Europe, and appears to be naturalized in some parts of Essex, where it has been long cultivated. It flowers in June and July, and the seeds ripen in July and August.

595

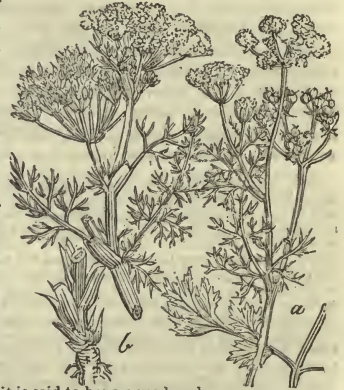

5450. *The culture and management of coriander*, consists in sowing it on a light rich soil in September, with seeds ripened the same year. Twenty pounds of seed will sow an acre. When the plants come up, thin them to six or eight inches distance every way, and next spring, stir the soil with a pronged hoe. In August the seed will be ripe, and if great care be not used, the largest and best part of it will be lost. To prevent this, women and children are employed to cut plant by plant, and to put it immediately into cloths, in which it is carried to some convenient part of the field, and there threshed upon a sail-cloth. A few strokes of the flail get the seeds clean out, and the threshers are ready for another bundle in a few minutes. In Essex it is sometimes cultivated with caraway and teazle. (See *Caraway*.)

5451. *The produce of coriander* is from ten to fourteen cwt. on an acre. It is used by the distillers for flavoring spirits; by the confectioners for incrusting with sugar; and by the druggists for various purposes, for all of which it is said to have a ready sale.

5452. *The Caraway (Carum carui, b)* is a biennial plant with a taper root, like a parsnep, but much smaller, running deep into the ground. The stems rise from eighteen inches to two feet, with spreading branches and finely cut deep green leaves. It is a native of England, in rich meadows in Lincolnshire and other places, and has been long cultivated in Essex. It flowers in May and June, and the seeds ripen in autumn.

5453. *The culture and management* is the same as that of coriander. In all probability both plants would answer if sown like clover among a crop of corn; hoed and thinned when the crop was removed, and again in the following spring. The method of culture in Essex is, about the beginning of March to plough some old pasture land; if it has been pasture for a century the better; and the soil should be a very strong clayey loam. Twelve pounds of caraway seed are mixed with ten pounds of coriander, and twelve pounds of teazle seed: this is sufficient for one acre; and is sowed directly after the plough, harrowing the land well. When the plants appear of sufficient strength to bear the hoe, which will not be until about ten weeks after sowing, it must not be omitted; and in the course of the summer, the crop will require three hoeings, besides one at Michaelmas. The coriander being annual, will be fit to cut about the beginning of July. It is left in the field after cutting, and threshed on a cloth in the same manner as rape seed. About April following the caraway and teazle will want a good hoeing done deep and well; and another about the beginning of June. The caraway will be fit to cut the beginning of July, and must be threshed in the same manner as the coriander. This compound crop is mostly sown on land, so strong, as to require being a little exhausted to make it fit for corn. Caraway and coriander are oftenest sown without teazle: the latter being a troublesome and uncertain crop, and the produce of caraway much greater without it.

5454. *The produce of caraway*, on the very rich old leys in the hundreds or low lands of Essex, has often been twenty cwt. to the acre. There is always a demand for the seed in the London market.

5455. *The uses of the caraway* are the same as those of coriander, and its oil and other preparations are more used in medicine. Dr. Anderson says, both the roots and tops may be given to cattle in spring.

SUBJECT. 3. *Of Plants which may be substituted for Brewery and Distillery Plants.*

5456. There are a great many plants with bitter juices which are or may be substituted for hops. In Sweden, Norway, and the north of Scotland, the heath (*Erica, L.*) and common broom, were, and still are, occasionally used for that purpose. In some parts of France and Germany nothing else is used but broom tops. In Guernsey, the *Teucrium scordonia* is used and found to answer perfectly. In England, the different species of mugwort and

wormwood have been used for that purpose; and the foreign bitter, quassia, a tree of Guiana, is still used by the porter brewers. Whoever has good malt, therefore, or roots, or sugar, and understands how to make them into beer, need be at no loss for bitters to make it keep.

5457. Of the *carminative seeds* there are a very considerable number of native or hardy plants that furnish them of equal strength, with those of the caraway and coriander, and of flavors to which the drinkers of cordials and liqueurs are also attached. Such, are the fennels (*Feniculum*), cultivated in Germany, parsley, myrrh, angelica, celery, carrot, parsnep, cow parsnep, and many other umbelliferous plants, avoiding, however, the hemlock, fool's parsley, æthusa, and some others which are poisonous. In Dantzic, where perhaps, more seeds are used for flavoring spirits than any where else, several of the above and other plants are employed. Kümmel, their favorite flavor, is that of the cumin (*Cuminum cyminum*), an annual plant, a native of Egypt, and cultivated in the south of Europe; but too tender for field culture in this country. But caraway or fennel seeds are very generally mixed with cumin, or even substituted for it in distilling kümmel-wasser.

### SECT. III. Of Oil Plants.

5458. In Britain there are few plants grown solely for the production of oil; though oil is expressed from the seeds of several plants, as the flax, hemp, &c. grown for other purposes. Our chief oil plant is the rape.

5459. Rape is the *Brassica napus*, L.; *Navette*, Fr.; *Rübsamen*, Ger.; *Naba silvestre*, Span.; and *Rapa silvatica*, Ital. It is a biennial plant of the turnip kind, but with a caulescent or woody fusiform root, scarcely fit to be eaten. Von Thaer considers the French and Flemish colza (*Kohlsaar*, Ger.) a different plant from our rape; colza is more of the cabbage kind, and distinguished by its cylindrical root, cut leaves, and greater hardness. Decandolle seems to be of the same opinion.

5460. According to these writers, *Brassica campestris oleifera* is the colsat or colza, or rape of the continent, the most valuable plant to cultivate for oil; its produce being to that of the *Brassica napus*, or British colsat or rape, as 955 to 700. It is distinguished from the *B. napus* by the hispidity of its leaves. It would be desirable for agriculture, Decandolle observes, that in all countries, cultivators would examine whether the plant they rear is the *B. campestris oleifera* or the *B. napus oleifera*, which can easily be ascertained by observing whether the young plant is rough or smooth; if hispid, it is the *B. campestris*; if glabrous, the *B. napus*. Experiments made by Gaujuc, shew the produce of the first, compared to that of the second, to be as 955 to 700. (*Hort. Trans.* v. 23.)

5461. For its leaves as food for sheep, and its seeds for the oil manufacturer, rape, or colseed, has been cultivated from time immemorial. It is considered a native, flowers in May, and ripens its seeds in July. It may be grown by sowing broad-cast, or in rows, like the common turnip, or transplanted like the Swedish turnip. The culture of rape for seed has been much objected to by some, on account of the great degree of exhaustion of the land that it is supposed to produce; but where it is grown on a suitable soil and preparation with proper attention in the after-culture, and the straw and offal, instead of being burnt, as is the common practice, converted to the purposes of feeding and littering cattle, it may, in many instances, be the most proper and advantageous crop that can be employed by the farmer.

5462. The soils best suited for rape are the deep, rich, dry, and kindly sorts; but, with plenty of manure and deep ploughing, it may be grown in others. Young says, that upon fen and peat soils and bogs, and black peaty low grounds, it thrives greatly, and especially on pared and burnt land, which is the best preparation for it; but it may be grown with perfect success on the fenny, marshy, and other coarse waste lands, that have been long under grass, after being broken up and reduced into a proper state of preparation. As a first crop on such descriptions of land, it is often the best that can be employed. The author of *The New Farmer's Calendar* thinks, that this plant is not perhaps worth attention on any but rich and deep soils; for instance, those luxuriant slips that are found by the sea-side, fens, or newly broken grounds, where vast crops of it may be raised.

5463. The preparation of old grass lands, if not pared and burned, need be nothing more than a deep ploughing and sufficient harrowing to bring the surface to a fine mould; and this operation should not be commenced in winter as some recommend, on account of the grub and wire-worm having time to rise to the surface; but in February or March, immediately before sowing, or in July or after the hay crop is removed, if the sowing is deferred till that season. When sown on old tillage lands, the method of preparation is pretty much the same as that which is usually given for the common turnip: the land being ploughed over four or five times, according to the condition it may be in, a fine state of pulverisation or tilth being requisite for the perfect growth of the crop. In

this view, the first ploughing is mostly given in the autumn, in order that the soil may be exposed to the influence of the atmosphere till the early part of the spring, when it should be again turned over twice, at proper intervals of time; and towards the beginning and middle of June one or two additional ploughings should be performed upon it in order that it may be in a fine mellow condition for the reception of the seed.

5464. *The place in a rotation of crops*, which rape occupies, is commonly between two of the culmiferous kind. On rich soils it may be succeeded to the greatest advantage by wheat, as it is found to be an excellent preparation for that sort of grain; and by its being taken off early, there is sufficient time allowed for getting the land in order for sowing wheat.

5465. *The season of sowing rape* is the same as that for the common turnip, and the manner, whether in broad-cast or rows, the same. The row method on the flat surface seems the best for newly broken up lands, and the rows on ridglets, with or without manure, the best for lands that have been under the plough. Where the object is the keep of sheep in autumn or winter by eating it down, the broad-cast method and thick sowing is evidently the best, and is that generally resorted to in Lincolnshire and the fenny districts. The quantity of seed when sown thick may be a peck an acre, but when drilled or sown thin, two or three pounds will suffice. The seed should be fresh, black, and plump. Vacancies may always be filled up by transplanting.

5466. *The season of transplanting* begins as soon after the corn harvest as possible, being generally performed on the stubble of some description of corn crop. One deep ploughing, and a sufficient degree of harrowing to pulverise the surface, is given, and the plants may be dibbled in in rows a foot apart, and six inches in the row or narrower, according to the lateness of the season of planting, and the quality of the soil; for it must be considered that plants transplanted so late as September or October will be far from being so strong the succeeding spring, as those sown in June and left where they are to run. The seed-bed from which the plants are obtained should have been sown in the June or July preceding the transplanting season, and may be merely a ridge or two in the same or in an adjoining field. We have already noticed (457.) the Flemish mode of transplanting by laying the plants in the furrow in the course of ploughing, but as the plants cannot be properly firmed at the lower part of the root, we cannot recommend it.

5467. *The after-culture of rape* is the same as that of the turnip, and consists in hoeing and thinning. The plants on the poorer soils may be left at six or eight inches apart or narrower, but on the rich they may be thinned to twelve or fifteen inches with advantage to the seed. Few are likely to grow the plant on ridglets with manure; but if this were done, the same distance as for turnips will ensure a better crop of seed than if the plants were closer together. In close crops the seed is only found on the summits of the plants; in wide ones on rich soils, it also covers their sides. When rape seed is grown purposely for sheep keep, no hoeing, thinning, or weeding, are necessary. Rape grown for seed will not be much injured by a very slight cropping by sheep early in the autumn, but considerably so by eating down in winter, or the succeeding spring. The seed begins to ripen in the last week of June, and must then be protected as much as possible from birds.

5468. *In harvesting rape* great care is requisite not to lose the seed by shaking, chaffing, or by exposing it to high winds or rains.

5469. *It is reaped with the hook*, and the principal point is to make good use of fine weather; for as it must be threshed as fast as reaped, or at least without being housed or stacked like other crops, it requires a greater number of hands in proportion to the land, than any other part of husbandry. The reaping is very delicate work, for if the men are not careful, they will shed much of the seed. Moving it to the threshing-floor is another work that requires attention; one way is to make little waggons on four wheels with poles, and cloths strained over them; the diameter of the wheels about two feet, the cloth body five feet wide, six long, and two deep, and drawn by one horse, the whole expense not more than 30s. or 40s. In large farms, several of these may be seen at work at a time in one field. The rape is lifted from the ground gently, and dropt at once into these machines without any loss; they carry it to the threshers, who keep hard at work, being supplied from the waggons as fast as they come, by one set of men, and their straw moved off the floor by another set; and many hands of all sorts being employed, a great breadth of land is finished in a day. Some use sledges prepared in the same way. All is liable to be stopped by rain, and the crop much damaged; it is, therefore, of very great consequence to employ as many people as possible, men, women, and boys, to make the greatest use of fine weather. The seed is likewise sometimes cleaned in the field, and put into sacks for the market. But when large quantities of seed are brought quickly together, as they are liable to heat and become mouldy, it may be a better method to spread them out thinly over a barn, granary, or other floor, and turn them as often as may be necessary.

5470. *The produce* where the plant succeeds well, and the season is favorable for securing the seed, is forty or fifty bushels or more on the acre. Marshal thinks, indeed, that on the whole it may be considered as one of the most profitable crops in husbandry. There have been, says he, instances, on cold unproductive old pasture-lands, in which the produce of the rape crop has been equal to the purchase value of the land. The



seed is sold by the last of ten quarters, for the purpose of having oil expressed from it, by mills constructed for that use. The price varies considerably, but has lately seldom been much below 30*l.* the last.

5471. *The use of the seed for crushing for oil is well known; it is also employed as food for tame birds, and sometimes it is sown by gardeners, in the same way as mustard and cress, for early salading.*

5472. *The rape-cake and rape-dust, the former adhering masses of seed husks, after the oil has been expressed, and the latter loose dry husks, are used as a top dressing for crops of different kinds. They are reduced into powder by a malt mill, or other grinding machine, and sometimes sown broad-cast over young clovers, wheats, &c. and at other times drilled along with turnip seed. Four cwt. of powder sown with turnip seed in drills, will go over one acre, but three times the quantity is required for an acre sown broad-cast. Experience has proved, that the success of this manure depends in a great measure on the following season. If rain happens to fall soon after the rape-dust is applied, the crop is generally abundant, but if no rain fall for a considerable period the effects of this manure are little discernible, either on the immediate crop, or on those which succeed it. There are turnip drills contrived so as to deposit the manure along with the seed. (2560.)*

5473. *The use of the haulm to cattle in winter is very considerable. The stover (pods and points broken off in threshing) is as acceptable as hay, and the tops are eaten with an avidity nearly equal to cut straw, at least better than wheat straw. When well got, the smaller stalks will be eaten up clean. The offal makes excellent litter for the farm-yard, and is useful for the bottoms of mows, stacks, &c. The haulm of this plant is frequently burned; and, in some places, the ashes, which are equal to potash, are sold; by which practice, if no manure be substituted, the soil must be greatly deteriorated. It is a custom in Lincolnshire, sometimes to lay lands down with cole, under which the grass seeds are found to grow well. But this sort of crop, as has been already observed, is most suited to fresh broken-up or burned lands, or as a successor to early pease, or such other green crops as are mowed for soiling cattle.*

5474. *The use of the leaves as a green food for sheep, is scarcely surpassed by any other vegetable, in so far as respects its nutritious properties, and that of being agreeable to the taste of the animals; but in quantity of produce, it is inferior to both turnips and cabbages. In this view the crops are fed off occasionally from the beginning of November to the middle of April: being found of great value, in the first period, in fattening dry ewes, and all sorts of old sheep; and, in the latter, for supporting ewes and lambs. The sheep are folded upon them in the same manner as practised for turnips, in which way they are found to pay from 50*s.* to 60*s.* the acre; that quantity being sufficient for the support of ten sheep, for ten or twelve weeks, or longer, according to circumstances. Rape has been found, by experience, to be superior to turnips in fattening sheep, and, in some cases, even to be apt to destroy them by its fattening quality. In *The Corrected Report of Lincolnshire*, it is likewise observed, that that which is grown on fresh land has the stem as brittle as glass, and is superior to every other kind of food in fattening sheep; while in that produced on old tillage land, the stem is tough and wiry, and has comparatively little nourishment in it.*

5475. *Among other plants which may be cultivated by the British farmer as oil plants, may be mentioned all the species of the Brassica family, the Sinapis or mustard family, and the Raphanis or radish family, with many others of the natural order of cruciferae. The seeds of these plants, when they remain too long on the seedsman's hands for growing, are sold either for crushing for oil, or grinding with mustard seed. This includes a good deal of wild charlock and wild mustard seed, which is separated in the process of cleaning grain by farmers, among whose corn these plants abound, and sold to the seed agents, who dispose of it to the oil or mustard millers. Various other cruciferae, as the Myagrum sativum, Raphanus chinensis, var. oleiferus, both cultivated in Germany, the Erysimum, Sisymbrium officinale, Turrites, &c. might also be cultivated for both purposes.*

5476. *The small or field poppy (Papaver Rhæas; Oilette, Fr.), and also the Maw seed (P. somniferum, var. Pavot, Fr.), a variety of the garden poppy, are, as we have seen (460.), cultivated on the continent as oil plants. The oil being esteemed in domestic economy next to that of the olive. Other species might be grown for the same purpose, all of them being annual plants require only to be sown on fine rich land in April; thinned out when they come up, to six or eight inches distance, according to the species; kept clear of weeds till they begin to run, and as the capsules ripen to be gathered by hand, and dried in the sun.*

5477. *The sunflower (Helianthus annuus; Turnesol, Fr., and Girasole, Ital.) has been cultivated in Germany for its seeds, which are found to yield a good table oil, and its husks are nourishing food for cattle.*

#### SECT. IV. *Plants used in Domestic Economy.*

5478. *Among agricultural plants used in domestic economy, we include the Mustard, Canary, Buck-wheat, Cress, Tobacco, Chicory, and a few others; with the exception of the two first, they are grown to a very small extent in Britain, and therefore our account of them shall be proportionately concise.*

SUBJECT 1. *Mustard*. — *Sinapis*, L. *Tetrad. Siliq. L.* and *Cruciferae*, J. *Moutarde* or *Sénévé*, Fr.; *Senf*, Ger.; *Mostaza*, Span.; and *Senapa*, Ital.

5479. *There are two species of mustard in cultivation in the fields, the white mustard (Sinapis alba, fig. 596 a), and the black or common (Sinapis nigra, b). Both are annuals, natives of Britain and most parts of Europe, and cultivated there and in China, for an unknown period. White mustard flowers in June, and ripens its seeds in July. Black mustard is rather earlier. Mustard is an exhausting crop, but profitable when the soil answers, and especially in breaking up rich loamy lands, as it comes off earlier, and allows time for preparing the soil for wheat. In breaking up very rich grass lands, three or four crops are sometimes taken in succession. It cannot however be considered as a good general crop for the farmer, even if there was a demand for it, as, like most of the commercial plants, it yields little or no manure. The culture of black or common mustard is by far the most extensive, and is chiefly carried on in the county of Durham. The seed of the black mustard, like that of the wild sort, and also of the wild radish, will remain in the ground, if below the depth of three or four inches, for ages without germinating, hence, once introduced it is difficult to extirpate. Whenever they throw the earth out of their ditches in the Isle of Ely, the bank comes up thick with mustard; the seed falling into the water and sinking to the bottom, will remain embalmed in the mud for ages without vegetation.*



5480. *Any rich loamy soil will raise a crop of mustard, and no other preparation is required than that of a good deep ploughing and harrowing sufficient to raise a mould on the surface. The seeds may be sown broad-cast at the rate of one lippie per acre; harrowed in and guarded from birds till it comes up, and hoed and wed before it begins to shoot. In Kent, according to the survey of Boys, white mustard is cultivated for the use of the seedsmen in London. In the tillage for it, the ploughed land is, he says, harrowed over, and then furrows are stricken about eleven or twelve inches apart, sowing the seed in the proportion of two or three gallons per acre in March. The crop is afterwards hoed and kept free from weeds.*

5481. *Mustard is reaped in the beginning of September, being tied in sheaves, and left three or four days on the stubble. It is then stacked in the field. It is remarked that rain damages it. A good crop is three or four quarters an acre: the price from 7s. to 20s. a bushel. Three or four crops are sometimes taken running, but this must in most cases be bad husbandry.*

5482. *The use of the white mustard is or should be chiefly for medical and horticultural purposes, though it is often ground into flour, and mixed with the black, which is much stronger, and far more difficult to free from its black husks. The black or common mustard is exclusively used for grinding into flour of mustard, and the black husk is separated by very delicate machinery. The French either do not attempt, or do not succeed in separating the husk, as their mustard when brought to table is always black. It is, however, more pungent than ours, because that quality resides chiefly in the husk. The constituents of mustard seed appear to be chiefly starch, mucus, a bland fixed oil, an acrid volatile oil, and an ammoniacal salt. The fresh powder, Dr. Cullen observes, shews little pungency; but when it has been moistened with vinegar and kept for a day, the essential acrid oil is evolved, and it is then much more acrid.*

5483. *The leaves of the mustard family, like those of all the radish and brassica tribe, are eaten green by cattle and sheep, and may be used as pot-herbs. The haulm is commonly burned; but is better employed as litter for the straw-yard, or for covering underdrains, if any happen to be forming at the time.*

5484. *As substitutes for either the black or common mustard, most of the Cruciferae enumerated when treating of oil plants (5475.), may be used, especially the Sinapis arvensis or charlock, S. orientalis, Chinensis, and Brassicata, the latter commonly cultivated in China. The Raphanis raphanistrum, common in corn-fields, and known as the wild mustard, is so complete a substitute, that it is often separated from the refuse corn and sold as Durham mustard seed.*

SUBJECT 2. *The Canary Grass*. — *Phalaris canariensis*, L. *Trian. Dig. L.* and *Gramineae*, J. (fig. 597.)

5485. *The canary grass is an annual, with a culm from a foot to eighteen inches in height, and lively green leaves almost half an inch in width. The seeds are thickly*

set in a subovate panicle or spike. It is a native of the Canary islands; but now naturalized in several parts of England, and on the continent. It flowers from June to August, and ripens its seeds from September to October. It has long been cultivated in the Isle of Thanet, and a few other places in Kent and Essex: it is there considered an uncertain crop, both on account of the seasons, it being the latest in ripening its seeds of all the grasses, and the fluctuation of prices.

5486. The culture of the canary grass consists in pulverising a loamy soil which is in good heart, or manuring it if worn out; though every judicious farmer tries to avoid giving manure to a corn crop unless after a naked fallow. The seeds are sown in rows at about a foot apart, generally by the ribbing process: the season the month of February, and the quantity of seed four or five gallons per acre. The after-culture consists in repeated hoings and weedings.

5487. The reaping process seldom commences before the end of September. The culm being leafy, and the seed difficult to separate from the chaff, it requires to lie in handfuls for a week or more, and to remain more than that time in the field after being tied up in sheaves. In the Isle of Thanet it is cut with a hook, provincially called a *twibil* and a *hink*; by which it is laid in lumps, or wads, of about a sheaf each. The seed clings remarkably to the husk; and, in order to detach it, the crop is left a long time on the ground, to receive moisture sufficient to loosen the enveloping chaff, otherwise it would be hardly possible to thresh out the seed. The wads are turned from time to time, to have the full benefit of the rains and sun.

5488. The common produce of canary grass is from thirty to thirty-four bushels per acre; but under the best management in the Isle of Thanet it is often fifty bushels per acre.

5489. The use of the seed is chiefly as food for Canary and other cage and aviary birds. The chaff is superior to that of every other culmiferous plant for horsefood, and the straw, though short, is also very nutritive.

SUBSECT. 3. *Buck-wheat*.—*Polygonum fagopyrum*, L. *Octan. Trig.* L.; and *Polygonæ*, J. *Blé noir* or *Blé Sarrasin*, Fr. (corrupted from Had-rasin, red corn, Celtic); *Buchweizen*, Ger.; *Trigo negro*, Span.; and *Miglio*, Ital. (fig. 598.)



598

5490. The buck-wheat, or more properly beech-wheat, (from the resemblance of the seeds to beech mast, as its Latin and German names import,) is an annual fibrous-rooted plant, with upright flexuose leafy stems, generally tinged with red, and rising from a foot to eighteen inches in height. The flowers are either white, or tinged with red, and make a handsome appearance in July, and the seeds ripen in August and September. Its native country is unknown; though it is attributed to Asia. It is cultivated in China and other countries of the east as a bread corn, and has been grown from time immemorial in Britain, and most parts of Europe as food for poultry, horses, and also for its meal to be used in domestic purposes. The universality of its culture is evidently owing to the little labor it requires: it will grow on the poorest soil, and produce a crop in the course of three or four months. It was cultivated so early as Gerard's time (1597), to be ploughed in as manure: but at present, from its inferior value as a grain, and its yielding very little haulm for fodder or manure, it is seldom grown but by gentlemen in their plantations to encourage game. Arthur Young, however, "recommends farmers in general to try this crop. Nineteen parishes out of twenty, through the kingdom, know it only by name. It has numerous excellencies, perhaps as many to good farmers, as any other grain or pulse in use. It is of an enriching nature, having the quality of preparing for wheat, or any other crop. One bushel sows an acre of land well, which is but a fourth of the expense of seed-barley. It should not be sown till the end of May. This is important, for it gives time in the spring to kill all the seed-weeds in the ground, and brings no disagreeable necessity from bad weather in March or April, to sow barley, &c. so late as to hazard the crop. It is as valuable as barley, and is the best of all crops for sowing grass-seeds with, giving them the same shelter as barley or oats, without robbing." If all these things were true at the time, they are now only matter of history.

5491. In the culture of the buck-wheat the soil may be prepared in different ways according to the intention of the future crop; and for this there is time till the end of

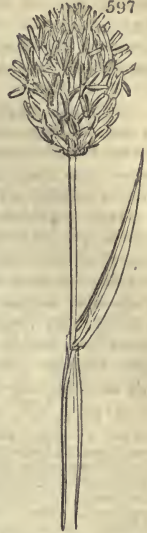

597

May, if seed is the object, and till June if it is to be ploughed in. It will grow on any soil, but only produce a good crop on one that is tolerably rich. It is considered one of the best crops to sow along with grass seed; and yet, (however inconsistent,) the voluminous writer last quoted, endeavours to prove, that buck-wheat, from the closeness of its growth at the top, smothered and destroy weeds, whilst clover and grass-seeds receive considerable benefit by the shade it affords them from the piercing heat of the sun!!

5492. *The season of sowing* cannot be considered earlier than the last week of April or first of May, as the young plants are very apt to be destroyed by frost. The mode is always broad-cast, and the quantity of seed a bushel per acre; it is harrowed in, and requires no other culture than pulling out the larger weeds, and guarding from birds till the reaping season.

5493. *Buck-wheat* is harvested by mowing in the manner of barley. After it is mown, it must lie several days, till the stalks be withered, before it be housed. It is in no danger of the seeds falling, nor does it suffer much by wet. From its great succulency it is liable to heat, on which account it is better to put it in small stacks of five or six loads each, than in either a large one or a barn.

5494. *The produce of the grain* of this plant may be stated upon the average, at between three and four quarters per acre; it would be considerably more did all the grains ripen together, but that never appears to be the case, as some parts of the same plant will be in flower, whilst others have perfected their seed.

5495. *The use of the grain* of buck-wheat in this country, is almost entirely for feeding poultry, pigeons, and swine. It may also be given to horses, which are said to thrive well on it; but the author of *The New Farmer's Calendar*, says, he thinks he has seen it produce a stupefying effect. It has been used in the distillery in England, and is a good deal used in that way, and also as horse-corn on the continent. Young says, a bushel goes farther than two bushels of oats, and mixed with at least four times as much bran, will be full feed for any horse a week. Four bushels of the meal, put up at four hundred weight, will fatten a hog of sixteen or twenty stone in three weeks, giving him afterwards three bushels of Indian corn or hog-pease, broken in a mill, with plenty of water. Eight bushels of buck-wheat meal will go as far as twelve bushels of barley meal.

5496. *The meal of buck-wheat* is made into thin cakes called crumpits in Italy and even in some parts of England, and it is supposed to be nutritious, and not apt to turn acid upon the stomach. (*Withering.*)

5497. *The blossoms* of this plant afford a rich repeat to bees, both from the quantity of honey they contain, and from their long duration. On this account it is much prized in France and Germany, and Du Hamel advises bee farmers to carry their hives to fields of this crop in the autumn, as well as to heath lands.

5498. *The haulm* of buck-wheat is said to be more nourishing than clover when cut while in flower. Banister says, it has a peculiar inebriating quality. He has seen hogs which have fed heartily on it, come home in such a state of intoxication as to be unable to walk without reeling. The dried haulm is not eaten readily by any description of animal, and affords but very little manure. On the whole, the crop is of most value when ploughed in green for the latter purpose. As a seed crop, the author of *The New Farmer's Calendar*, seems justified in saying, it is only valuable on land that will grow nothing else. The *Polygonum tartaricum* has been recommended for field culture, but Von Thaer, who tried it repeatedly, found its produce quite insignificant.

SUBJECT. 4. *Of other Plants used in Domestic Economy; which are or may be cultivated in the Fields.*

5499. *Many garden plants might be cultivated in the fields*, especially near large towns where manure is easily procured, and a demand for the produce exists. Among such plants may be mentioned the cress, parsley, onion, leek, lettuce, radish, &c. There are also some plants which enter into the agriculture of foreign countries where the climate is not dissimilar to our own, which might be very effectually cultivated in this country were it desirable. Among these are the tobacco and the chicory, the latter for its roots as a substitute for coffee. The lettuce might be grown for its milky juice, as a substitute for, or rather a variety of opium. Of dwarf fruits, as the strawberry, currant, gooseberry, raspberry, &c. we add nothing here, having already alluded to them in treating of orchards.

5500. The agriculturist who attempts to grow any of the above plants, can hardly expect to succeed unless his knowledge extends beyond the mere routine of country husbandry, either by reading and the study of the nature of vegetables, or by some experience in the practice of gardening. No farmer on a moderately extensive scale will find it worth while to attempt such productions, whatever may be his knowledge or resources; and for the garden-farmer, or the curious or speculative amateur, we would recommend observation and enquiry round the metropolis, and the reading of books on horticulture. All that we shall do here, will be to give some indications of the culture and management of cress, chicory, and tobacco.

5501. *The garden cress* (*Lepidum sativum*, L.), too well known to require any description, is grown in the fields in Essex, the seed being in some demand in the London market.

It is sown on any sort of soil, but strong loam is the most productive. After being well pulverised on the surface, the seed is sown broad-cast and lightly harrowed in. The season of sowing for the largest produce is March, but it will ripen if sown the first week in May. The quantity of seed to an acre varies from two to four pecks, according to the richness of the land; the seed will not grow the second year. No after-culture is required but weeding. The crop is reaped and left in handfuls to dry for a few days, and then threshed out like rapeseed or mustard in the field.

5502. *The use of the cress seed is chiefly for sowing to cut for young turkeys; and for forcing salads by the London cooks on hot moist flannels and porous earthenware vessels. A very considerable quantity is also used in horticulture, it being one of the chief early salads, and cut when in the seed leaf. The haulm is of very little use as litter, and on the whole, the crop is exhausting.*

5503. *The culture of the chicory as an herbage plant has already been given (5074.); when grown for the root to be used as a substitute for coffee, it may be sown on the same soil as the carrot, and thinned out to the same distance as that plant. These roots are taken up in the first autumn after sowing in the same manner as those of the carrot. When they are to be manufactured on a large scale, they are partially dried, and in that state sold to the manufacturers of the article, who wash them, cut them in pieces, roast them on a kiln, and grind them between fluted rollers into a powder, which is packed up in papers, containing from two ounces to three or four pounds. In that state it is sold either as a substitute for coffee, or for mixing with it. But when a private family cultivate this plant for home manufacture, the roots are laid in a cellar among sand, and a few taken out as wanted, washed, cut into slices, roasted in the coffee roaster till they become of a brown color, and then passed as wanted through the coffee mill.*

5504. *The value of the chicory as a coffee plant, Von Thaer observes in 1810, is proved by its having been cultivated for that purpose for thirty years. Dr. Howison has written some curious papers on the subject in *The Caledonian Horticultural Memoirs*, (vol iv.), and both that gentleman and Dr. Duncan approve of its dietetic qualities. The former indeed says, he thinks it preferable to coffee, which may be a matter of taste, as some prefer the flavor of the powdered roots of dandelion to that of either coffee or chicory. Dr. Duncan is of opinion that chicory might be cultivated with great national advantages as a substitute for the exotic berry. (*Disco. to Caled. Hort. Soc.* 1820.)*

5505. *Of the tobacco, there are two species which may be cultivated in this country: the Nicotiana tabacum, or Virginia tobacco, which is almost the only sort imported, and the N. rustica, common tobacco, the Bauern tabac of Germany, and cultivated in that country, Sweden, and many parts of France, Switzerland, Holland, &c., both for private use and manufacture for public sale. Almost every one who occupies a cottage and garden in these countries grows as much as supplies their pipes; but it is rarely made into snuff or chewing tobacco by private families. The culture of tobacco is prohibited in Britain for political reasons; but before that law was given, it was grown and cured in a very sufficient manner by farmers both in England and Scotland. At present every family may grow a sufficient quantity for their own use.*

5506. *The soil for tobacco must be deep, loamy, and rich; well pulverised before planting, and frequently stirred and kept free from weeds during the growth of the plants. The plants in this country should be raised in a warm part of the garden: the seed is very small, and should be sown and lightly covered, and then the surface pressed down with the back of the spade in the middle of March. In May they will be fit to transplant, and should be placed in lines three feet apart every way. If no rain fall, they should be watered two or three times. Every morning and evening the plants must be looked over, in order to destroy a worm which sometimes invades the bud. When they are about four or five inches high, they are to be cleared from weeds and moulded up. As soon as they have eight or nine leaves; and are ready to put forth a stalk, the top is nipped off, in order to make the leaves longer and thicker. After this the buds which sprout at the joints of the leaves are all plucked, and not a day is suffered to pass without examining the leaves, to destroy a large caterpillar, which is sometimes very destructive to them.*

5507. *The following is the mode of taking and fermenting the leaves in America. When they are fit for cutting, which is known by the brittleness of the leaves, they are cut with a knife close to the ground; and after lying some time, are carried to the drying shed or house, where the plants are hung up by pairs, upon lines, leaving a space between, that they may not touch one another. In this state they remain to sweat and dry. When perfectly dry, the leaves are stripped from the stalks, and made into small bundles, tied with one of the leaves. These bundles are laid in heaps, and covered with blankets. Care is taken not to overheat them, for which reason the heaps are laid open to the air from time to time, and spread abroad. This operation is repeated till no more heat is perceived in the heaps, and the tobacco is then stowed in casks for exportation.*

5508. *To save seed allow one or two of the best plants to run, they will flower and be very ornamental in June, July, and August, and ripen their seeds in September and October.*

5509. *In the manufacture of tobacco, the leaves are first cleaned of any earth, dirt, or decayed parts; next they are gently moistened with salt and water, or water in which some other salt, and sometimes other ingredients have been dissolved, according to the taste of the fabricator. This liquor is called tobacco sauce. The next operation is to remove the midrib of the leaf, then the leaves are mixed together to render the quality of whatever may be the final manufacture or application equal; next they are cut into pieces with a fixed knife, and crisped or curled before a fire; the succeeding operation is to spin them into cords, or twist them into rolls by winding them with a kind of mill round a stick. These operations are performed by the grower, and in this state (of rolls) the article is sent from America to other countries, where the tobaccoists cut it into chaff like shreds by a machine like a straw-cutter, for smoking; form it into small cords for chewing; or dry and grind it for snuff. In manufacturing snuff various matters are added to give it an agreeable scent; and hence the numerous varieties of snuff. The three principal kinds are called rappes, Scotch or Spanish, and thirds. The first is only granulated; the second is reduced to a very fine powder, and the third is the siftings of the second sort. In a former section (5439.) we have hinted that no farmer who cultivates the hop need be without a vegetable equal to asparagus, or fibre similar to that of flax to employ his servants in spinning; and from the foregoing observations it would seem that whoever has a garden may grow his own coffee and tobacco.*

SECT. V. *Of Plants which are or may be grown in the Fields for Medicinal Purposes.*

5510. A number of medical plants were formerly grown in the fields; but vegetable drugs are now much less the fashion; a few powerful sorts are retained, which are either collected wild or are natives of other countries, and the rest of the pharmacopœia is chiefly made up of minerals. It may safely be affirmed that there are no plants belonging to this section which deserve the notice of the general farmer; but we have thought it desirable to notice a few sometimes grown by farming gardeners, and which may be considered as belonging almost equally to horticulture and agriculture, or as points of connection between the two arts. These are the saffron, liquorice, rhubarb, lavender, mints, chamomile, and thyme.

5511. *The saffron or autumn crocus (Crocus sativus, L. fig. 599 a.),* is a bulbous-rooted

599



perennial, which has been long cultivated in the south of Europe, and since Edward III.'s time in England, and chiefly at Saffron Walden in Essex. It was abundantly cultivated there, and in Cambridgeshire, Suffolk, and Herefordshire, in the beginning of the seventeenth century, but the quantity of land under this crop has been gradually lessening for the last century, and especially within the last fifty years, so that its culture is now almost entirely confined to a few parishes round Saffron Walden. (*Young's Essex.*) This is owing partly to the material being less in use than formerly, and partly to the large importations from the East, often, as Professor Martyn observes, adulterated with bastard saffron (*Carthamus tinctorius*) and marygold (*Calendula officinalis*).

5512. The bulbs of the saffron are planted on a prepared soil not poor nor a very stiff clay, but if possible a hazel mould on chalk. The bulbs are planted in July, in rows six inches apart across the ridges, and at three inches distance in the rows.

5513. The flowers, which are purple and appear in September, are gathered, carried home, and the stigmas picked out, together with a portion of the style; these are dried on a kiln between layers of paper, and under the pressure of a thick board to form the mass into cakes.

5514. Two pounds of dried cake is the average crop of an acre after first planting, and twenty-four pounds for the two next years. After the third crop the roots are taken up, divided, and re-planted.

5515. The uses of saffron in medicine, domestic economy, and the arts, are various. It is detergent, resolvent, anodyne, cephalic, ophthalmic, &c.; but its use is not without danger: in large doses it promotes drowsiness, lethargy, vomiting, and delirium; even its smell is injurious, and has been known to produce syncope. It is used in sauces by the Spaniards and Poles; here and in France it enters into creams, biscuits, conserves, liquors, &c. and is used for coloring butter and cheese, and also by painters and dyers.

5516. *The liquorice (Glycyrrhiza glabra, L. fig. 599 b.)* is a deep-rooting perennial, of the leguminosæ, with herbaceous stems rising four or five feet high. It has long been much cultivated in Spain; and since Elizabeth's time has been grown in different parts of England.

5517. *The soil for the liquorice should be a deep sandy loam, trenched by the spade or plough, or the aid of both, to two and a half or three feet in depth, and manured if necessary.* The plants are procured from old plantations, and consist of the side roots, which have eyes or buds. These may be taken off, either in autumn when a crop of liquorice is taken up for use, and laid in earth till spring, or taken from a growing plantation, as wanted for planting. The planting season may be either October, or February and March. In general the latter is preferred. The plants are dibbled in in rows three feet apart, and from eighteen inches to two feet in the row, according to the richness of the soil. The after-culture consists in horse-hoeing and deep stirring, in weeding, and in cutting over and carrying away the haulm every autumn after it is completely withered. As the plants do not rise above a foot the first season, a crop of onions or beans is sometimes taken in the intervals. The plants must have three summers' growth, at the end of which the roots may be taken up by trenching over the ground. The roots are either immediately sold to the brewers' druggists, or to common druggists, or preserved, like carrots or potatoes, in sand, till wanted for use. They are used in medicine and porter-brewing.

5518. *The rhubarb (Rheum palmatum, L. fig. 599 c.)* is a perennial, with thick oval roots, which strike deep into the ground, large palmate leaves, and flower-stems six or eight feet high. The Society of Arts exerted themselves for many years to promote the culture of this plant, as did Dr. Hope, of Edinburgh. It has accordingly

been cultivated with success both in England and Scotland; though the quality of the root produced is considered by the faculty as inferior to that of the Russia or Turkey rhubarb, probably, as Professor Martyn thinks, owing to the moisture of our climate, and the imperfect mode in which it has been dried.

5519. *In the culture of this plant, if bulk of produce be the object, then a deep, rich, loamy sand, should be chosen; but if flavor, then a dry, warm, somewhat calcareous sand. Prepare, as for liquorice, and sow the seeds in patches of two or three seeds, in rows four feet apart, and the same distance in the rows. Transplanting from seed-beds may be adopted; but the roots are never so handsome and entire. As soon as the plants appear, leave only one in a place. The plants will now stand in the angles of squares of four feet to the side; and the after-culture consists in horse-hoeing and deep stirring, both lengthways and across; in ploughing in the same directions; in never letting the flower-stems rise higher than two feet, or shew flowers or seed, unless some is wanted for propagation; and in removing the decayed haulm every autumn. The plants having stood three or four summers, may be taken up, and their main roots dried in a very slow manner by any of the following modes:—The common British mode of curing or drying the rhubarb, after cleaning the roots, is to cut them into sections, an inch or more in thickness, string them and dry them in airy lofts, laundries, or kitchens, in a gradual manner. This has long been the practice of private gardeners who grow the root for their own use, and has also been adopted by cultivators for the druggists. The rhubarb is cured in Tartary by being thoroughly cleaned, the smaller branches cut off, and then cut transversely into pieces of a moderate size; these are placed on long tables or boards, and turned three or four times a day, that the yellow viscid juice may incorporate with the substance of the root. If this juice be suffered to run out, the roots become light and unserviceable; and if they be not cut within five or six days after they are dug up, they become soft and decay very speedily. Four or five days after they are cut, holes are made through them, and they are hung up to dry exposed to the air and wind, but sheltered from the sun. Thus, in about two months, the roots are completely dried, and arrive at their full perfection. The loss of weight in drying is very considerable; seven loads of green roots yielding only one small horse-load of perfectly dry rhubarb.*

5520. *The Chinese in curing rhubarb, after having cleaned the roots, by scraping off the outer bark, as well as the thin yellow membrane underneath, cut them in slices, an inch or two in thickness, and dry them on stone slabs, under which large fires are kindled. They keep continually turning these slices on the warm slabs; but as this operation is not sufficient to dry them thoroughly, they make a hole through them, and suspend them on lines, in a place exposed to the greatest heat of the sun, till they are in a condition to be preserved without danger of spoiling. A copious account of all the experiments made in Britain for the culture and curing of the rhubarb up to 1805, is given by Professor Martyn, in his edition of Miller's Dictionary, art. *Rheum*; and of the Turkey, Russian, and Chinese rhubarb, in Thomson's Dispensatory, 2d edit. 1822, p. 469.*

5521. *The lavender (*Lavandula spica*, L. fig. 599 d) is a dwarf odoriferous shrub of three or four years' duration, grown in the fields in a few places round London, and chiefly in Surrey, for the spikes of flowers used by the druggists, perfumers, and distillers. The soil should be a poor dry calcareous gravel; the seeds being sown in a garden in spring, may be transplanted in September or March following, in rows two feet apart and kept free of weeds. The second season they will yield a few flowers, and a full crop the fourth, after which the plants will continue productive for five or six years. The spikes are gathered in June, dried in the shade, and sold in bundles to the herbalists, druggists, &c.*

5522. *Thyme, wormwood, marjoram, savory, and some other aromatics, are cultivated in the same manner, and for similar purposes. Being usually smaller plants, they should be planted closer, but to have much flavor the soil must be dry and calcareous.*

5523. *Chamomile (*Anthemis nobilis*) is a creeping perennial, grown for its flowers. It only requires to be planted on a poor soil, in rows a foot apart and hoed between. It will produce abundance of flowers annually from June to September, which are gathered, and dried in the shade. They are sold by weight to the druggists and apothecaries. The double-flowered variety is, from its beauty, that commonly cultivated; but the single possesses more of the virtues of the plant according to its weight.*

5524. *The mints (*Mentha*), and especially the peppermint (*Mentha piperitis*), are creeping rooted perennials, cultivated on rich marshy or soft black moist soils for distilling. The plants are grown in beds with trenches of a foot or more in width and depth between, so as to admit of irrigation. The sets are obtained from old plantations, and planted in rows across the beds at six inches distance every way, in March or April. No produce is obtained the first year worth notice, but a full crop the third, and the shoots will continue to produce five or six years. The spikes of flowers, and in some cases the entire herbage, is cut over in June as soon as the flowers expand, and carried immediately to the druggist's still. Some growers distil it themselves.*

5525. *The common valerian (*Valeriana officinalis*, L.) is sometimes cultivated for its roots for the druggists. It is a native plant, and prefers a loamy soil. In Derbyshire it is planted in rows twelve inches apart, and the plants six inches asunder, which are either procured from the offsets of former plantations, or from wild plants found in wet places in the neighboring woods. Soon after it comes up in the spring the tops are cut off, to prevent its running to seed, which spoils it. At Michaelmas, the leaves are pulled and given to cattle, and the roots dug up carefully, and clean washed, and the remaining top is then cut close off, and the thickest part slit down to facilitate their drying, which is effected on a kiln, after which they must be packed tight, and kept very dry, or they spoil. The usual produce is about 18 cwt. per acre. This crop is manured in the winter, of which it requires a great deal.*

5526. *The orchis or saley plant (*Orchis mascula*, L.) is a tuberous perennial, which grows plentifully in moist meadows in Gloucestershire, and other parts of the country. It flowers in May and ripens seeds in July. It has been proposed to be cultivated for*

its tubers to be used as salep; but the plant is very difficult of propagation from seed, and can hardly be multiplied at all by the root, and though it may answer to collect the tubers and prepare them, it is not likely it ever will to attempt their culture. As the plant is very abundant in some situations, it may be useful to know its preparation, which is thus described in *Phil. Trans.* vol. lix.

5527. *The bulb is to be washed in water, and the fine brown skin which covers it, is to be separated by means of a small brush, or by dipping the root in hot water, and rubbing it with a coarse linen cloth. When a sufficient number of bulbs is thus cleansed, they are to be spread on a tin plate, and placed in an oven heated to the usual degree, where they are to remain six or ten minutes, in which time they will have lost their milky whiteness, and acquired a transparency like horn, without any diminution of bulk. Being arrived at this state, they are to be removed, in order to dry and harden in the air, which will require several days to effect, or by using a gentle heat, they may be finished in a few hours. By another process, the bulb is boiled in water, freed from the skin, and afterwards suspended in the air to dry; it thus gains the same appearance as the foreign salep, and does not grow moist or mouldy in wet weather, which those that have been barely dried by heat are liable to. Reduced into powder, they soften and dissolve in boiling water into a kind of muilage, which may be diluted for use with a large quantity of water or milk. Thus prepared, they possess very nutritious virtues; and if not the very same species as is brought from Turkey and used for making salep, so nearly resembles it as to be little inferior. In Turkey the different species of the orchis are said to be taken indifferently; but in England, the orchis mascula is the most common. (Gloucestershire Report, 377.)*

## CHAP. IX.

### *Of Marine Plants used in Agriculture.*

5528. *All marine plants may be used as manure with great advantage, either in a recent state or mixed with earth. But the most valuable vegetables which grow in or near salt water, are those from which kelp or soda may be manufactured. The use of sea-weed, as an article from which kelp might be manufactured, seems to have been practically recognised in Scotland about the beginning of the eighteenth century. The great demand for kelp in the manufacture of glass and soap at Newcastle, and of alum at Whitby, seems to have introduced the making of this commodity upon the shores of the Forth, so early as about the year 1720. It began to be manufactured in the Orkney Islands in the year 1723, but in the western shires of Scotland, the making of kelp was not known for many years after this date. The great progress of the bleaching of linen cloth in Ireland, first gave rise to the manufacture of kelp in that kingdom; and from Ireland it was transferred to the Hebrides about the middle of the eighteenth century. On the shores of England the kelp plants are not abundant.*

5529. *Of the different marine plants which are employed for the manufacture of kelp, the Fucus vesiculosus (fig. 600 a), is considered by kelp makers as the most productive; and the kelp obtained is, in general, supposed to be of the best quality.*



5530. *The fucus nodosus (b), is considered to afford a kelp of equal value to that of the above species, though perhaps it is not quite so productive.*

5531. *The fucus serratus (c) or black weed, as it is commonly called, is neither so productive, nor is the kelp procured from it so valuable as that obtained from the other two. This weed is seldom employed alone for the manufacture of kelp; it is in general mixed with some of the other kinds.*

5532. *The fucus digitatus (d), is said to afford a kelp inferior in quality to any of the others; it forms the principal part of the drift-weed.*

5533. *The plants are cut in May, June, and July; and exposed to the air on the ground, till they be nearly dried, care being taken to prevent them, as much as possible, from being exposed to the rain. They are then burned, either in a pit dug in the sand or on the surface of the ground, surrounded by loose stones, forming in both ways a rude sort of kiln. A peat fire is kindled on the ground, and the weed gradually added, till the*



fire extends over the whole floor of the kiln; the weed is then spread lightly on the top, and added in successive portions. As it burns it leaves ashes, which accumulating towards evening, become semifused, and are then well stirred. Another day's burning increases the mass; and this is continued till the kiln is nearly filled. On some occasions the kiln consists of a cavity in the ground, over which bars of iron are placed; and on this the ware is burned, the ashes falling into the cavity, where they are well worked by the proper instruments.

5534. *Kelp is generally divided into two kinds; the cut-weed kelp, and the drift-weed kelp; the former made from the weed which has been recently cut from the rocks, the latter from that which has been drifted ashore. The latter is supposed to yield a kelp of inferior quality. Some specimens of kelp, however, made from sea-weed, which had been drifted ashore, tend to prove that this is not always the case. Weed which has been exposed to rain during the process of drying, affords a kelp of inferior quality. It is of the utmost importance to the manufacturer of kelp, to keep his weed as much as possible free from rain. For this purpose many employ sheds; when these are not at hand, the weed which has been laid out to dry, should be collected into one heap during the rain; when this ceases, it should again be immediately spread out. It has often been matter of dispute, how old the plants should be before they be cut. In general, three years is the time allotted. This, however, from some trials which have been made to ascertain this point, seems to be too long. From experiments, it appears, that the produce of kelp, from one ton of three years old weed, is only eight pounds more than that from the same quantity of two years old; from this we would conclude, that the weed ought to be cut every two years. Though perhaps less weed may be procured from the same extent of ground occupied by weed of two, than of three year's growth, yet the difference may not be so great as to render it worth while to allow the weed to remain for three years.*

5535. *In order to increase the quantity of kelp, it has been suggested to the Highland Society, that the seed of the salsola soda might be imported and cultivated at a small distance from the shore, with the design of mixing the plant with the sea-ware, for the improvement of the kelp. It was formerly imagined, that the barilla plant would not produce any quantity of alkali, worth its cultivation, if planted in France; but in the year 1782, some spirited individuals procured a quantity of barilla seed, and made a plantation of it near the coast of the Mediterranean, in the province of Languedoc, and had the satisfaction for several years, to find, that the barilla which they produced from these plants, was of a quality equal to that which they usually procured from Alicante. Why, then, may not a similar attempt in our own country be equally successful?*

5536. *Other plants. If the growers of kelp could contrive to make some considerable plantations of the most productive of the kali, or of fumitory, wormwood, and other inland plants, which yield large quantities of potash, and collect the crop to burn with the other materials, the carbonate of potash resulting from their incineration would decompose the sea salt, and a great accumulation of carbonate of soda would be produced. It was proved long ago by Du Hamel, that the marine plants produced soda merely in consequence of their situation, for, when they have been cultivated for some years in an inland spot, they yield only potash.*

5537. *There are immense tracts of shore on the mainland and islands of Scotland which may be easily cultivated for the production of kelp, from which at present not one penny is derived. All the cultivation requisite is, to place whin or other hard stones, not under the size of the crown of a hat, upon such vacant spaces. Contracts have been made to plant shore lands in the Highlands with such stones, at the rate of 20*l.* per Scots acre. Such stones are generally to be found at high-water mark, on all the shores of the lochs of the Highlands. They are put into a boat at high water, then carried to the ground to be planted, and thrown overboard, and on the ebb of the tide they are distributed regularly over the shore, preserving a clear space round every stone of one foot, which distance, after very minute examination, appears to be the most eligible for producing the greatest crop of ware. It is evident these stones should be of a round shape, the more surface being exposed to the alternation of the air and water, so much more kelp-ware will be produced from a given space of ground. In four years the first crop may be cut, which, on the above data, will yield about four per cent. on the original expense. But the crop may be manufactured into kelp in every third year thereafter, which, on the same data, is equal to about five per cent. In this improvement there is no hazard of bad crops, and if the manufacture is begun early enough in the season, there is little danger to be apprehended from bad weather, it being understood that the operation of kelp-making can be carried on, should there be no more than two dry days in eight. (*Highland Society's Trans.* vol. viii.)*

## CHAP. X.

### *Of Weeds or Plants which are injurious to those cultivated in Agriculture.*

5538. *Every plant which appears where it is not wanted may be considered injurious, though some are much more so than others. A stalk of barley in a field of oats is a weed, relatively to the latter crop, but a thistle is a weed in any crop; weeds, therefore, may be classed as relative and absolute.*

5539. *Relative weeds*, or such cultivated plants as spring up where they are not wanted, give comparatively little trouble in extirpating them. The most numerous are the grasses when they spring up in fields of saintfoin or lucern, or among corn crops in newly broken up grass lands. The roots of chiccory, in fields that have been broken up after bearing that crop for some years, of madder, liquorice, &c. are also of difficult extirpation. When the potatoe crop has not been carefully gathered, or mustard has been allowed to shed its seed, they also occasion trouble. Other similar cases will readily occur to the practical man, and need not be mentioned.

5540. *Absolute weeds*, or such native plants as are considered injurious to all crops, are very numerous, and may be variously arranged. Some affect in a more peculiar manner corn-fields and tillage lands, and these are chiefly annuals, as wild mustard, wild radish, poppy, blue bottle, cockle, darnel, &c. ; or biennials, as the thistle ; or perennials, as couch-grass, knot-grass, black couch, polygonum, &c. ; on lands laid down to grass for a few years, dock, ox-eye daisy, ragweed, &c. Others infest grass lands, and these are chiefly perennials, such as crowfoot, one of the most difficult of weeds to extirpate ; thistles, docks, rushes, sedges, moss, and an endless variety of others. Some are more particularly abundant in hedges, of which the reedy and coarse grasses, as couch-grass, bromegrass, and the climbing and twining plants, as goose grass (*Galium aparine*), and the twiners, as bindweed (*Convolvulus*), are the most injurious.

5541. With regard to the *destruction of weeds*, they may be classed first, according to their duration. All annuals and biennials, as sandwort (fig. 601 *b*), and sorrel (*c*), are effectually destroyed by cutting over the plant at any point below that whence the seed leaves originated, as this prevents them from ever springing again from the roots. Perennials of the fibrous-rooted kind may be destroyed in the same manner, as the crowfoot, ragweed, the fibrous-rooted grasses, and many others. Some fusiform rooted perennials may also be destroyed by similar means ; but almost all the thick rooted perennials require to be wholly eradicated.

5542. *The perennial weeds which require their roots to be wholly eradicated*, may be classed according to the kind of roots. The first we shall mention are the stoloniferous roots or surface shoots of plants, by which they propagate themselves. Of this kind is the creeping crowfoot, goosefoot or wild tansy, and other potentillas, mints, strawberries, black couch-grass, and most of the agrostidæ and other grasses. The next are the under-ground creeping roots, as the couch-grass, convolvulus arvensis, and other species, of bind-weed, coltsfoot (fig. 601 *a*) sowthistle, several tetradynamous plants, as todflax, scrophularia, nettle, hedge-nettle, (*Stachys*), lamium, ballota, &c. Some of these, as the bindweed and corn-mint, are extremely difficult to eradicate : a single inch of stolone, if left in the ground, sending up a shoot and becoming a plant. The creeping and descending vivacious roots are the most difficult of all to eradicate. Of this class are the polygonum amphibium, (fig. 602 *a*), the reed (*Arundo phragmites*), the horse-tail (*Equisetum*, fig. 602 *b*), and some others. These plants abound in deep clays, which have been deposited by water, as in the carse and clay-vales of Scotland. In the carse of Falkirk for example, the roots of the polygonum amphibium are found every where in the subsoil alive and vigorous. They send up a few leaves every year in the furrows and on the sides of drains, and when any field is neglected or left a year or two in grass, they are found all over its surface. Were this tract to be left to nature for a few years, it would soon be as completely covered with the polygonum as it must have been at a former age, when it was one entire marsh partially covered by the Firth of Forth. The horse-tail is equally abundant in many soils, even of a drier description ; and the corn thistle, (*Serratula arvensis*, fig. 601 *e*) even in dry rocky grounds. Lightfoot (*Flora Scotica*) mentions plants of this species dug out of a quarry, the roots of which were nineteen feet in length. It would be useless to attempt eradicating the roots of such plants. The only means of keeping them under, is to cut off their tops or shoots as soon as they appear ; for which purpose, lands subject to them are best kept in tillage. In grass lands, though they may be kept from rising high, yet they will, after being repeatedly mown, form a stool or stock of leaves on the surface, which will suffice to strengthen their roots, and greatly to injure the useful herbage plants and grasses.



5543. *Tuberous and bulbous rooted weeds*, are not very numerous; wild garlick, arum, and bryony, are examples, and these are only to be destroyed by complete eradication.



5544. *Ramose, fusiform, and such like rooted perennials*, of which rest-harrow, fern, and scabious are examples, may in general be destroyed by cutting over below the collar or point where the seed-leaves have issued. Below that point the great majority of plants, ligneous as well as herbaceous, have no power of sending up shoots; though there are many exceptions, such as the dock, burdock, &c. among herbs, and the thorn, elm, poplar, cherry, crab, &c. among trees.

5545. *A catalogue of weeds* could be of little use to the agriculturist, as the mere names could never instruct him as to their qualities as weeds, even if he knew them by their proper names. Besides, weeds which abound most, and are most injurious in one district, are often rare in another. Thus, the poppy abounds in gravelly districts, the charlocks on clays, the chickweed, groundsoil, nettle, &c. only on rich soils. A local flora, or any of the national floras, as Lightfoot's *Flora Scotica*, and Smith's *British Flora*, by pointing out the native habits of indigenous plants, may be of considerable use to the agriculturist who has acquired a slight degree of the science of botany, so as to enable him to refer any plant which he may pick up in flower, not knowing the name, to its place in the arrangement of the book.

---

BOOK VII.

THE ECONOMY OF LIVE STOCK AND THE DAIRY.

5546. *The grand characteristic of modern British farming*, and that which constitutes its greatest excellence, is the union of the cultivation of live stock with that of vegetables. Formerly in this country, and in most other countries, the growing of corn and the rearing of cattle and sheep constituted two distinct branches of farming; and it was a question among writers, as Von Thier informs us it still is in Germany, which were the most desirable branches to follow. The culture of roots and herbage crops at last led gradually to the soiling or stall feeding husbandry, in imitation of the Flemings; and afterwards, about the middle of the last century, to the alternate husbandry, which is entirely of British invention, and has been the means of improving the agriculture of the districts where it is practised, more effectually than any thing else. It is observed

by Brown, that "though horses, neat cattle, sheep, and swine are of equal importance to the British farmer with corn crops, yet we have few treatises concerning the animals, compared with the immense number that have been written on the management of arable land, or the crops produced upon it. But though so little has been written, the improvement of those animals has not been neglected; on the contrary, it has been studied like a science, and carried into execution with the most sedulous attention and dexterity. We wish it could be stated, that one half of the care had been applied to the selecting and breeding of wheat and other grains, which has been displayed in selecting and breeding the best proportioned and most kindly feeding sheep. A comparison cannot, however, be made with the slightest degree of success; the exertions of the sheep-farmers having, in every point of view, far exceeded what has been done by the renters of arable land. Even with cattle considerable improvement has taken place. With horses, those of the racing and hunting kinds excepted, there has not been correspondent improvement; and as to swine, an animal of great benefit to the farmer, in consuming offal which would otherwise be of no value, it is to be regretted that very much remains to be done."

5547. *The first important effort in the improvement of live stock*, was made by Robert Bakewell, of Dishly, about 1730; and the first scientific work which appeared on the subject, was by George Cully, in 1782. Bakewell wrote nothing himself; but the principles on which he acted in selecting and breeding cattle and sheep, have been developed, by his contemporaries, in various agricultural reports. Some excellent observations on the subject have also appeared from the pens of Cline, Dr. Coventry, Sir. J. Sebright, Hunt of Leicester, and others. The improvement in the sciences of comparative anatomy and physiology has also led to an amended practice both in breeding and in pathology. The example of various opulent proprietors and farmers in all parts of the empire, tended to spread this improvement, by which the pursuit became fashionable. Add to these the accounts of the management of live stock in almost every county of the British Isles, as contained in Marshal's *Works* and the *County Reports*. From these sources we shall draw the information we are about to submit, and shall adopt the arrangement of the horse, the ass, the mule and hinny, the bull family and the dairy, the sheep, the swine, minor stock, and injurious animals or vermin.

---

#### CHAP. I.

*The cultivated Horse.* — *Equus Caballus*, L.; *Mammalia Belluæ*, L.; and *Pachydermes Solipedes*, Cuvier; *Cheval*, Fr.; *Pferde*, Ger.; *Caballo*, Span.; and *Cavallo*, Ital.

5548. *The horse family*, by far the most important among the brute creation as a servant to man, includes several species both in a wild and cultivated state, as the *Equus hemionus* or wild mule, a native of Arabia and China, and which it is supposed would form an excellent race of small horses, could they be reduced to a state of domestication; the *E. asinus*, or ass, well known; the *E. zebra*, or striped ass; the *E. quagga*, by some considered a variety of the zebra; and the *E. bisulcus* or cloven-footed horse, a native of Chili, and by many supposed to belong to a distinct genus.

5549. *The common horse*, justly considered as the noblest of animals, is found in a wild state in the deserts of Great Tartary, in the southern parts of Siberia, and in other parts of Asia, and in the interior of Africa. He is of the greatest antiquity, and has long been domesticated and cultivated in most parts of the earth, for the various purposes of war, hunting, parade, the saddle, or draught; and in some places, partly for his flesh and the milk of the female. The parts of a horse, when no longer endowed with life, are applied to various useful purposes: the blood for manure; the bones are broken and boiled, to produce oil, and afterwards are ground into an excellent manure; some of the bones are also used in the mechanical arts. The flesh supplies food for the domestic carnivorous animals, the cat and dog; for carnivorous birds, as the hawk, eagle, &c., kept for amusement or curiosity; and for fish and various similar purposes. We shall consider the horse, in regard to its varieties, organology, anatomy, physiology, diseases, breeding, rearing, training, feeding, and working.

#### SECT. I. *Of the Varieties of the Horse.*

5550. *The varieties of the domestic horse* vary exceedingly in different countries. The Arabian horse (*fig. 603.*) is a portrait of one brought by Buonaparte from

Egypt, and now living in the royal garden of Paris,) are reckoned the best, and their inhabitants the most expert in horsemanship. The care taken by the Arabs in preserving the breeds of their horses, is most remarkable. None but stallions of the finest form and purest blood are allowed access to their mares, which is never permitted but in the presence of a professional witness or public officer, who attests the fact, records the name, and signs the pedigree of each. The Persian horses are considered next in value; and after them the horses of Andalusia in Spain. The Barbary horses are descended from the Arabians, and much esteemed. Jackson (*Empire of Morocco*, p. 42.) mentions one very fleet variety, used for hunting the ostrich, and fed entirely on camel's milk.

603

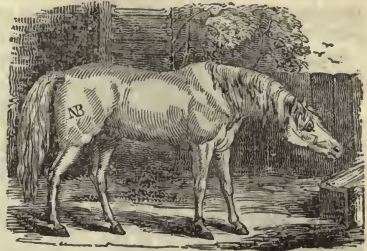

In Algiers they are said not to like to castrate their horses, but only squeeze their testicles when they are about three months old, which renders them incapable of propagation. The horses of India are small and vicious, the climate being unfavorable to their greater development. Those of Tartary are of a moderate size; but strong, muscular, full of spirit and active. The Tartars are considered skilful riders. Like the Kalmucks, they eat their flesh as we do that of oxen, and use their milk either in curd or fermented.

5551. *Of the European varieties of the horse*, those of Italy were formerly in greater esteem than at present; but still, those of the Neapolitans shine both under the saddle and in traces. Great numbers are bred in Sicily; those of Sardinia and Corsica are small, but active and spirited. The Swiss horses partake of the same qualities.

5552. *The Spanish horses* are much commended: some make them second to the Arabians, and place them before the Barb. Those of the finest breeds are generally finely carcassed and well limbed horses, active, ready and easy in their paces, docile and affectionate to their owners, full of spirit and courage, but tempered with mildness and good nature; they are for the most part, of a moderate size. Those which are bred in Upper Andalusia are deemed the most valuable. The Portuguese horses, or rather mares, were famous of old for being very fleet and long-winded; but of late it is said they are much degenerated.

5553. *France* abounds in horses of all kinds, but does not excel in native breeds; the best of those fit for the saddle come from Limousin: they resemble the Barbs in many particulars, and like them are fittest for hunting, but they are supposed not to be fit for work before they are seven or eight years old. There are also very good "Bidets" or ponies, in Auvergne, Poitou, and Burgundy. Next to those of Limousin, Normandy claims precedence, for a well formed and useful breed. Lower Normandy and the district of Cotentin furnish some very tolerable coach horses, and which are more active and appear more elastic in their motions than the Dutch horses. They have, however, a noble race of large draught horses equal to any seen in England, and, among which, the chestnut color seems to prevail. The French horses generally are apt to have their shoulders although oblique, yet too loose and open, as those of the Barbs are usually too confined and narrow.

5554. *The Flemish horses* are inferior in value to the Dutch, having usually large heavy heads and necks; their feet also are immoderately large and flat, and their legs subject to watery humours and swellings.

5555. *Holland* furnishes a race of horses which are principally serviceable in light draught work: the best come from Friesland.

5556. *Germany* is not destitute of good horses, and such as prove useful for many purposes; but they are reckoned to be heavy and defective in wind. The Germans possess, however, finer breeds obtained from Turks and Barbs which are kept as stallions; they obtain also some good specimens from the Italians and Spaniards. As racers and hunters they are inferior to the Hungarian and Transylvanian horses. The horses of Bohemia are not distinguished by any eminent qualities. The Hussars and Transylvanians are accustomed to slit the nostrils of their horses, under a notion of giving their breath a free passage, and improving their wind, as well as to render them incapable of neighing, which, in the field, would be often inconvenient. The Croatian horses are nearly allied in qualities and character to the Hungarian and Bohemian: these, as well as the Poles, are remarkable for being, as the French term it, "Begut," or keeping the mark in their teeth as long as they live.

5557. *The Polish horses* are hardy, strong, and useful, but they are generally of a middling size. In the marshy parts of Prussia, and towards the mouth of the Vistula, there is a breed of tall, strong horses, resembling those of Friesland, but of inferior value.

5558. *The horses of Bussia* are not much regarded by other nations. They are small but hardy, and capable of enduring great fatigue. Great attention is, however, paid to such as are very fast in their trot, and such a breed is much encouraged for trotting matches on the snow and ice. Those of the Turkish breed are handsome and finely shaped, but too slight and weak for heavy cavalry. The Kalmuck horses are somewhat higher than the Russian common horses, and are so lasting and constitutionally strong as to be able to run three or four hundred English miles in three days. They subsist, summer and winter, solely upon grass in the great deserts which are between the rivers Don, Volga, and Yaik, where they are collected in great herds of four hundred, five hundred, or even a thousand. They are excellent swimmers, and pass the river Volga, where it is from one to two miles broad, with great ease.

5559. *The horses of Sweden* are low and small, and the Norway breed may be comprehended under the same description, but they are strong, hardy, and active. Denmark, and also Holstein and Oldenburg, boast a large variety of horses, which has long been esteemed as peculiarly adapted for heavy cavalry and carriage uses, though they are apt to fail with respect to elegance of limb and symmetry of parts; their heads being large, their shoulders heavy, their backs long, with croups too narrow to correspond with their fore parts. In the islands of Ferøe there is a race of horses of small growth, but strong, speedy, and very sure-footed. They are never shod, and feed abroad without shelter both summer and winter. In Suederoe, one of these islands, they have a peculiarly swift breed, of great use to the inhabitants, who catch their sheep, which are wild, by hunting them with a dog, pursuing them at the same time with their horses. The horses of Lapland are small of stature, but active and willing; they are used only in

the winter season, in drawing sledges over the snow, and transporting wood, forage, and other necessities; but in summer they are turned into the forests, where they form separate troops, strictly confined to their own quarters.

5560. *The British varieties of saddle horse* may be reduced into the racer, the hunter, the improved hack, the old English road horse, the galloway, and the pony; the two latter of which we shall consider in another place.

5561. *The race horse* (fig. 604) is descended, some from Arabians and others from Barbs, but principally the former. Races or courses were very early a part of British sports; and it is natural to suppose that on this account, endeavors would be made to improve and enlarge the breeds of the native horses. Roger de Bellesme, Earl of Shrewsbury, is the first on record who imported a Spanish stallion, whose progeny was afterwards extolled by Michael Drayton, in his *Polyolbion*. In the reign of Henry IV., public ordinances were made favorable to the improvement of the breeding of horses. The courses of those times were, however, probably little more than ordinary trials of speed between the *indigenæ* or the slightly improved breeds; and it was not until the days of Henry VII. and VIII., that the true Arabian horses were imported. During these reigns, stallions from Arabia, Barbary, and Persia were procured, their progeny were regularly trained to the course, and from these periods we trace that gradual cultivation of the English race horse, which has, at length, produced a breed unrivalled throughout the world for symmetry of form, swiftness of progression, and durability under exertion. The accounts on record of feats performed by some of our horses on the turf are truly astonishing. Bay Malton, ran at York, four miles in seven minutes and forty-three seconds. Childers, known by the name of the flying Childers, moved through a space equal to eighty-two feet and a half in a second. After these Eclipse, Highflyer, Matchem, Hambletonian, and others, have contributed to keep up the reputation of the English racer.

5562. *Climate has a great influence over the form of animals*, and that form is found indigenous to each, which best fits it for the purposes required of it. In the arid plains of the east where herbage is scarce, a form is given which enables its brute inhabitants to readily transport themselves from one spot to another; and as in every situation the flesh of the horse is greedily sought after by the predatory tribes, so here, where those are peculiarly strong and active, the horse is formed peculiarly agile and swift to escape their attack, as well as peculiarly light, that his weight might not sink him in the sandy plains, nor his bulk retard him in his flight. Removed, however, to more temperate climes, where vegetation affords by its luxuriance more nutriment, and where the restrictions of danger have ceased to operate, we no longer see him equally small and slender, but with equal capacity for swift progression, we find him expanded into a form capable of keeping up that progression with a durability unknown to the original breeds from whence he sprang. Symmetrically formed as we now see him, he at once evinces his claim to great speed. His osseous or bony skeleton exhibits a base founded on the justest geometrical principles, presenting a series of lengthened levers acting by means of a condensed muscular and tendinous organization of great power, on angles capable of great flexion and extension; while his pointed form fits him to cleave that atmosphere, from which his deep chest enables him to draw by extensive inspirations wind and vigour to continue his exertions. Purity of blood, by which is meant the result of confining to particular races or breeds the means of continuing their species, is observed with equal care and jealousy by the breeders of the English race, as by the Arabians; and turf jockies assert they can discover a taint or departure from this purity to the sixteenth remove.

5563. *The hunter* (fig. 605.) is derived from horses of entire blood, or such as are but little removed from it, uniting with mares of substance, correct form, and good action. In some instances hunters are derived from large mares of the pure breed, propagating with powerful stallions of the old English road horse. This favorite and valuable breed is a happy combination of the speed of the Arabian, with the durability of the native horse. More extended in form, but framed on the same principles, he is able to carry a considerable weight through heavy grounds with a swiftness equalled only by the animal he pursues, and with a perseverance astonishing to the natives of every other country. Hence the extreme demand for this breed of horses in every European country; our racing stallions being now sent to propagate in the eastern climes, from whence they were some of them originally brought.

5564. *The improved hackney* (fig. 606.) is derived, like the former, from a judicious mixture of the blood breed with the native horse, but exhibiting a greater proportion of the latter. Hacknies are now, however, mostly bred from stallions possessing nearly the same proportion of blood with the hunter; but with a form and qualities somewhat differing. In the hackney as safety is as requisite as speed, we look particularly to the fore parts to see that they are high and well-placed; that the head is not heavy, nor the neck disproportionately long or short; that the legs stand straight, (that is, that a perpendicular line drawn from the point of the shoulder should meet the toe); and that the elbows turn out: and although a perfect conformation in the hinder parts is necessary to the hackney, it is in some measure subordinate to the same perfection in the fore parts; whereas in the racer and hunter, but particularly in the former, the form of the hinder is even of more consequence than that of the fore parts.

5565. *The old English road horse*. This most useful breed is now nearly extinct, although some northern agriculturists appear to be making efforts to revive the

race. It has so long been known in this country that it might almost be reckoned among its *indigenæ*: although it is probable that it originally sprang from a judicious culture from horses of Norman, German,

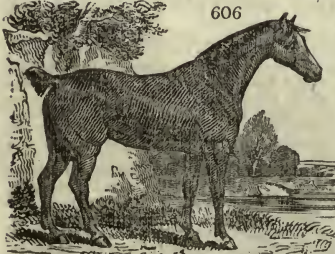
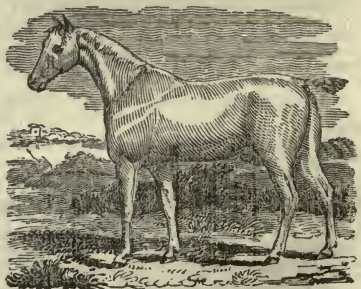
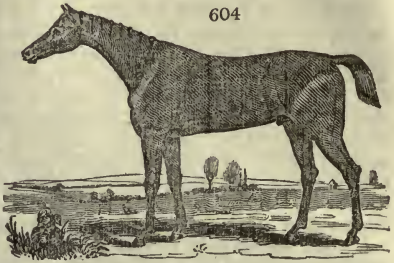

or Flemish extraction, which horses were very early imported to enlarge our smaller breeds, and to render them equal to the heavy loads they were accustomed to carry as pack-horses; and of which kind the old English road horse unquestionably is. (fig. 607.) Neither is it at all impossible, that in the more fertile parts of the island, an original breed existed of considerable power and bulk. Athelstan expressly prohibited the exportation of English horses, and the "scythed chariots drawn by fiery steeds" of the ancient Britons struck terror even into Caesar's legions. These accounts of the antiquity of the English horse, receive additional strength from the notices we obtain of the fossil bones of horses having been found, according to Parkinson, in various parts of the island. The old English road horse possessed great power, with short joints, a moderate shoulder, elevated crest, with legs and feet almost invariably good. The heights varied from fifteen hands to fifteen hands two inches; and the colors were frequently mixed.

607

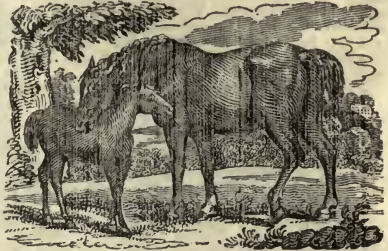

5566. *The objection, however, to English horses* both of the original and of the more early improved breeds, and which is even still seen among them, is, that they want grace or expression in their figure and carriage; that they are obstinate and sullen, and that a certain stiffness in their shoulders, and want of suppleness and elasticity in their limbs, renders them unfit for the manege. As this is an important charge against the excellence of our breeds, it may be worth consideration how far it is founded in truth. Commerce requires despatch, and England as a great commercial country makes every thing subservient to an economical use of time. Conformable to these principles, many of the qualities of our horses, but principally those of flexibility and safety in progression, are certainly sacrificed to speed, in which they undoubtedly excel all horses in the world. It is well known that all animals intended by nature for quick progression, are formed low in their fore parts, and have usually narrow upright shoulders; and which defects are too common in English horses in general. On the contrary, in most of the improved breeds of continental horses, the fore hands are elevated, and the shoulders wide and oblique; by which, flexibility and safety in progression are gained at some expense of celerity; for the strong lumbar muscles of such formed horses, operating on the lengthened spinous processes of the dorsal vertebrae with increased advantage, elevate the fore parts higher; and even in default of this form in the fore parts, yet a corresponding effect is produced in foreign horses by the great strength and expansion of their haunches and croups, and by the greater inclination in their hinder extremities towards the common centre of gravity of the body: for as speed depends first on the extent to which the angles of the limbs can be opened, and secondly, on the efforts of the body in its transit to counteract the tendency to the common centre of gravity, the earth; so it is evident that the form which is the most favorable to speed, is less so to safety or flexibility in progression.

5567. *The Irish road horse, or hunter, coeval with, or probably in some measure subsequent to the culture of the old English road horse, was a still more excellent breed.* With similar properties, but an improved form, with a great acquired aptitude for leaping, it gained the name of the Irish hunter; and when the dogs of the chase were less speedy than they now are, this horse was equal to every thing required of him as a hunter; even now the possessors of the few which remain find, particularly in an enclosed and deep country, that what others gain by speed these accomplish by strength to go through any ground, and activity sufficient to accomplish the most extraordinary leaps. As roasters, these horses have ever proved valuable, uniting durability, ease, and safety with extreme docility. In form they may be considered as affording a happy mixture of an improved hack with our old English roaster.

5568. *The British varieties of saddle horse of more inferior description* are very numerous, as cobs, galloways, and ponies. Cobs are a thick, compact, hackney breed, from fourteen hands to fourteen hands two inches high, in great request for elderly and heavy persons to ride, or to drive in low phaetons, &c. Galloways and ponies are lately in much request also for low chaises; a demand which will lead to a cultivation of their form; the number bred requires little increase, as several waste districts or moors throughout England are already appropriated principally to the purpose of rearing ponies.

5569. *The British varieties of war or cavalry horse, and of carriage and cart horse, are considered to have been derived from the German and Flemish breeds, meliorated by judicious culture.* Most of the superior varieties contain a mixture of Arabian or Spanish blood. Cavalry horses are found amongst the larger sort of hacknies; and the observations made in the late wars sufficiently shew the justice of the selection. Except in a few unhappy instances, where a mistaken admiration of the Hulans had led to selecting them too light, the English cavalry horse possessed a decided superiority over the best French horses in strength and activity, as well as over the Germans, whose horses, on the other hand, by their bulk and heavy make, were incapable of seconding the efforts of the British dragoons. The coach, chariot, and stage horses are derived, many of them from the Cleveland bays, further improved by a mixture of blood. Others are bred from a judicious union of blood and bone, made by the breeders in Yorkshire, Lincolnshire, and other midland counties.

5570. *The varieties of draught horse* were originally as numerous as the districts from whence they were bred, each having its favorite breed; but since the intercourse among farmers and breeders has been greater, those in common use are so mixed as to render it difficult to determine of what variety they partake the most. At present, the principally esteemed draught horses are the Suffolk punch, the Cleveland bay, the black, and the Lanark or Clydesdale. The native breeds of draught horses of England, Scotland, Wales, and Ireland, are much too small for the purposes of agricultural draught as now conducted; but by cultivation, the improved breeds pointed out, have furnished such animals as are equal to every thing required of them.

608

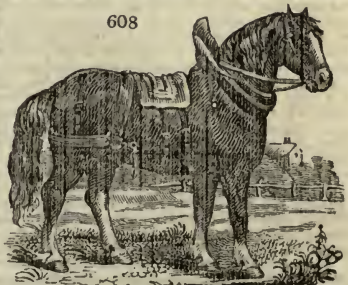

5571. *The black horse (fig. 608.), bred in the midland counties of England, is a noble and useful animal; and furnishes those grand teams we see in the coal, flour, and other heavy carts and waggons about London; where the immense weight of the animal's body assists his accompanying strength to move the heaviest loads. But the present system of farming requires horses of less bulk and more activity for the usual agricultural purposes, better adapted for travelling, and more capable of enduring fatigue; consequently this breed is seldom seen in the improved farms. The black cart horse is understood to have been formed, or at least to have been brought to its present state, by means of stallions and mares imported from the low countries; though there appears to be some difference in the accounts that have been preserved, in regard to the places from whence they were originally brought, and to the persons who introduced them, (Culley on Live Stock, p. 32., and*

*Marshal's Economy of the Midland Counties*, vol. i. p. 306.) Marshal, under too confined a view, and probably prejudiced against the breed on account of its fancied want of spirit, as well as for the alleged tendency to become flat and pomiced in the feet, is most unreasonably severe on it, when he says, "the breed of grey rats, with which this island has of late years been overrun, are not a greater pest in it than the breed of black fen horses; at least while cattle remain scarce as they are at present, and while the flesh of horses remains to be rejected as an article of human food." (*Marshal's Yorkshire*, vol. ii. p. 164). The present improved sub-variety of this breed is said to have taken its rise in six Zealand mares, sent over from the Hague by the late Lord Chesterfield, during his embassy at that court.

5572. *The Cleveland bays* (fig. 609.), which owe some of their most valuable properties to crosses with



the race-horse, have been long celebrated as one of the best breeds in the island; but they are said to have degenerated of late. They are reared to a great extent in Yorkshire, the farmers of which county are remarkable for their knowledge in every thing that relates to this species of live stock. In activity and hardiness, these horses, perhaps, have no superior. Some capital hunters have been produced by putting full-bred stallions to mares of this sort; but the chief object latterly has been to breed coach-horses, and such as have sufficient strength for a two-horse plough. Three of these horses carry a ton and a half of coals, travelling sixty miles in twenty-four hours, without any other rest but two or three bays upon the road; and frequently perform this labor four times a-week.

5573. *The Suffolk punch* (fig. 610.) is a very useful animal for rural labor, and is particularly esteemed by the farmers of Norfolk, Suffolk, and Essex, but the merit of this breed seems to consist more in constitutional hardiness than in any apparent superiority of shape. "Their color is mostly yellowish or sorrel, with a white ratch or blaze on their faces; the head large, ears wide, muzzle coarse, fore-end low, back long, sometimes, but always very straight, sides flat, shoulders too far forward, hind-quarters middling, but rather high about the hips, legs round and short in the posteriors, deep-bellied, and full in the flank. Here, perhaps, lies much of the merit of these horses; for we know, from observation and experience, that all deep-bellied horses carry their food long, and, consequently, are enabled to stand longer and harder days' works. However, certain it is, that these horses do perform surprising days' works. It is well known, that the Suffolk and Norfolk farmers plough more land in a day than any other people in the island; and these are the kind of horses every where used in those districts." (*Culley on Live Stock*, p. 27.) Since Culley's time much pains have been taken to improve this useful breed, and to render them,

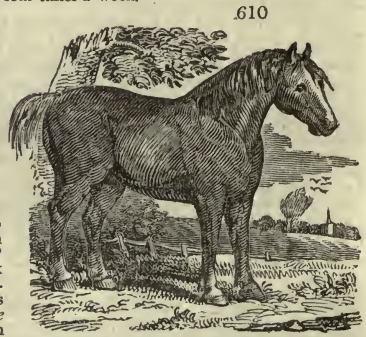

by cultivation, fitted not only for heavy but for light work. So great has been the estimation of this breed in Ireland, that Beresford of —, procured from Suffolk a cart stallion, for which he gave a hundred guineas; and which he allowed to cover all the Suffolk mares brought to him gratis.

5574. *The Clydesdale horse* (fig. 611.) has been long in high repute in Scotland and the north of England; and, for the purposes of the farmer, is probably equal to any other breed in Britain. Of the origin of this race, various accounts have been given, but none of them so clear, or so well authenticated as to merit any notice. They have got this name, not because they are bred only in Clydesdale or Lanarkshire, for the same description of horses are reared in the other western counties of Scotland, and over all that tract which lies between the Clyde and the Forth, but because the principal markets at which they are sold, Lanark, Carnwath, Rutherglen, and Glasgow, are situated in that district, where they are also preserved in a state of greater purity than in most other parts. They are rather larger than the Suffolk punches, and the neck is somewhat longer; their color is black, brown, or grey, and a white spot on the face is esteemed a mark of beauty. The breast is broad; the shoulder thick, with the reaching cartilaginous portion of the blade-bone nearly as high as the withers, and not so much thrown backwards as in road horses; the hoof round, and usually black, with wide heels; the back straight and broad, but not too long; the hucks visible, but not prominent, and the space between them and the ribs short; the tail heavy, and well haired; the thighs meeting each other so near as to leave only a small groove for the tail to rest on. One most valuable property of this breed is, that they are remarkably true pullers, a restive horse being rarely found among them.

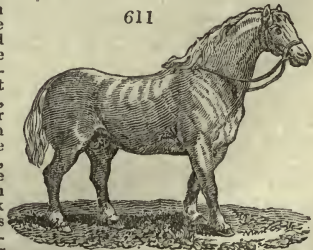

5575. *The Welsh horse* (fig. 612 a) bears a near resemblance, in point of size and hardiness, to the best of the native breed of the highlands of Scotland, and other hilly countries in the north of Europe. It is too small for the present two-horse ploughs; but few horses are equal to them for enduring fatigue on the road. "I well remember," says Culley, "one that I rode for many years, which, to the last,



would have gone upon a pavement by choice, in preference to a softer road." (*Observations on Live Stock*, p. 35.)



612

5576. *The galloway (b)*, so called from its being found chiefly in that province of Scotland, has now become very rare; it is a little horse, of much the same size with the former, or rather larger; the breed having been neglected from its unfitness for the present labors of agriculture. The true galloways are said to resemble the Spanish horses; and there is a tradition, that some of the latter, that had escaped from one of the vessels of the Armada, wrecked on the coast of Galloway, were allowed to intermix with the native race. Such of this breed as have been preserved in any degree of purity, are of a light bay or brown color, with black legs, and are easily distinguished by the smallness of their head and neck, and the clearness of their bone.

5577. *The still smaller horses of the Highlands and isles of Scotland, (c)* are distinguished from larger breeds by the several appellations of *ponies, shelties*, and in Gaelic of *garrons or gearrons*. They are reared in great numbers in the Hebrides, or western isles, where they are found in the greatest purity. Different varieties of the same race are spread over all the Highland district, and the northern isles. This ancient breed is supposed to have been introduced into Scotland from Scandinavia, when the Norwegians and Danes first obtained a footing in these parts. "It is precisely the same breed that subsists at present in Norway, the Feroe Isles, and Iceland, and is totally distinct from every thing of horse kind on the continent of Europe, south of the Baltic. In confirmation of this, there is one peculiar variety of the horse in the Highlands, that deserves to be noticed: it is there called the *eel-backed horse*. He is of different colors, light bay, dun, and sometimes cream-colored; but has always a blackish list that runs along the ridge of the back, from the shoulder to the rump, which has a resemblance to an eel stretched out. This very singular character subsists also in many of the horses of Norway, and is no where else known." (*Walker's Hebrides*, vol. ii. p. 158.) "The Highland horse is sometimes only nine, and seldom twelve hands high, excepting in some of the southern of the Hebrides, where the size has been raised to thirteen or fourteen hands by selection and better feeding. The best of this breed are handsomely shaped, have small legs, large manes, little neat heads, and are extremely active and hardy. The common colors are grey, bay, and black; the last is the favorite one." (*General Report of Scotland*, vol. iii. p. 176.)

## SECT. II. *Organology or exterior Anatomy of the Horse.*

5578. A just knowledge of the *exterior conformation of the horse*, to be able to form a correct judgment of the relative qualities of the animal, forms the *ne plus ultra* of a scientific horseman's aim; but it is a branch of knowledge not to be obtained without much study and experience. In considering a horse exteriorly, his age, his condition, and other circumstances should be attended to; and without which attention it is not possible to determine, with precision, the present or future state of a horse when he is seen under various peculiarities. A horse of five years old, though considered as full grown, yet experiences very considerable alterations of form after that period. He then becomes what is termed *furnished*; and all his points, before hidden in the plumpness of youth, now shew themselves. He is, in fact, more angular, and in a painter's eye would be more picturesque, but less beautiful. A horse likewise low in flesh and condition, is hardly the same animal as one in full flesh and condition; and again, the sleekness acquired from relaxed labor, with full and gross feeding, is very unlike the robust form acquired from generous diet with correspondent exertion.

5579. *The examination of the subject of organology* is conveniently pursued by dividing it into head, neck, trunk, or body, and extremities or legs. The greater number of well proportioned horses, with the exception of the head and neck, come within a quadrangle; but not one strictly equilateral as depicted by Lawrence (Richard), and Clark; but one whose horizontal dimensions are usually between a twenty-fourth and twenty-eighth greater than their perpendiculars. It must, however, be kept in mind, that with some considerable deviations from this quadrangular form, many horses have proved superiorly gifted in their powers; and that a deviation from these proportions, appears in some instances, as in that of the race horse, not only favorable, but necessary also to his exertions. Nature will not be limited, and the perfection of her operations is not alone dependant on an arbitrary arrangement of parts, but on a harmony and accordance of the whole, internal as well as external. To the artist, however, such admeasurement is useful, inasmuch as it prevents any singular departure from a symmetrical appearance, which is but too common among our animal draughtsmen. To the amateur it also offers a convenient, though not an unerring guide. Our exemplification of the organology appears by placing a blood and a cart horse within the same square (fig. 613), by which the differences between the various parts of the one and the other are readily contrasted.

5580. *The organs of the head.* The head of the horse is remarkable for its dimensions, formed by an elongation of the jaws; yet in him, as in most of the grazing tribes, its bulk is in an inverse proportion to

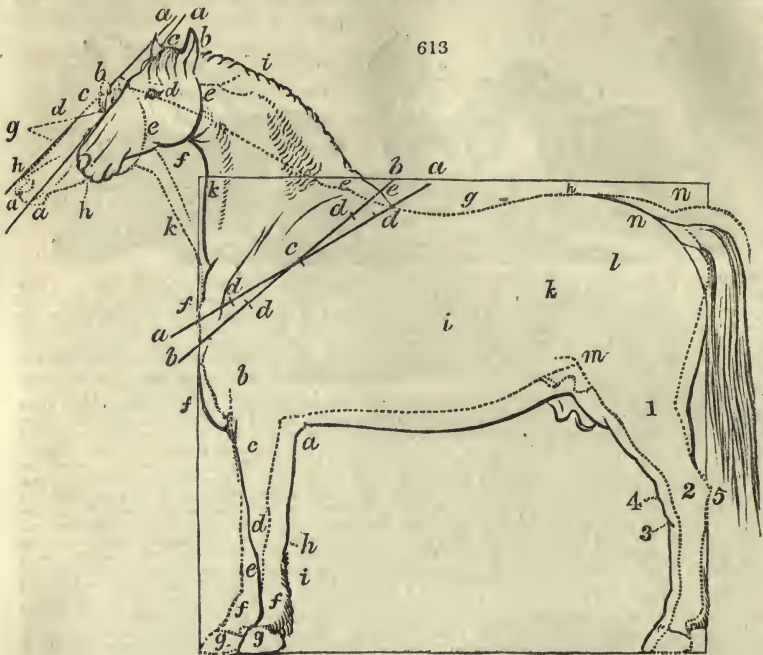

the length of the neck, otherwise the muscles would not be able to lift it. It is an important part considered as relative to beauty alone, it being in the inferior heavy breeds but little marked by grace or expression; but in the improved varieties it presents lines worthy the painter's pencil and the poet's fancy. Neither is it too much to say, that in no part of the body is this amelioration of breed so soon detected as in the head. Can anything be conceived more dissimilar than the small inexpressive features of the cart horse, and the bold striking ones that grace the head of the blood horse? The quick succession of movements in his pointed ears, the dilations of his expanded nostrils, or his retroverted eyes, which give fire and animation to the character of his head when under the influence of any excitement. This is the more worthy of remark, when it is considered that some of the principal aids to expression in the human countenance are wanting in the horse. Man borrows much of his facial expression from his eyebrows, and when to these the varied action of the mouth is added, it amounts to more than a half of the total expression. A great accession of beauty is gained in the improved breeds by the increase to the facial angle, which in them is about  $25^\circ$ , but in the heavy breeds is usually only  $23^\circ$  (a a a).

5581. *The ears* (b b) in the improved breeds are small and pointed; in the heavy they are not only large and ill shaped, but they frequently separate from each other: these defects gave rise to the barbarous custom of cropping, now happily in a great measure abolished. The ears are criteria of the spirit, as well as of the temper; we have seldom seen a horse which carried one ear forward and the other backward during his work, that was not hardy and lasting. Being not subjected to early fatigue, he is attentive to every thing around him, and directs his ears different ways to collect sound from every quarter. The ears are also indications of temper, and a horse is seldom either playful or vicious, but his ears are laid flat on the neck. It is fortunate that we are provided with such a warning, by an animal that does not want craft to surprise us, nor strength to render his resentment terrible.

5582. *The forehead* next presents itself (c c), straight, and of a proper width in the improved breeds, adorned by nature with an elegant portion of hair, which, detaching itself from the rest of the mane, flows down the face to protect both that and the ears from the attacks of insects.

5583. *The eyes* (d d) deserve particular attention, not only for their utility, but as objects of beauty and expression. In the blood horse the orbital fosse, or eye sockets, are more prominent and more inclined, by which the axes of his eyes diverge more from each other than those of the heavy breed; by which not only he is enabled to see further behind him, but the prominence of his eyes gives great beauty and expression to the blood head. The further consideration of the eyes and their criteria of soundness, will be postponed to the anatomical detail. In old horses most of the fat of the body which is superficially placed, becomes absorbed; in this way the eye, which is usually embedded in a vast quantity of this matter, losing its assistance, sinks within its orbits, and thus the cavities above, called eye-pits, shew themselves deeply in an aged horse.

5584. *From the ears to the angle of the jaws* (e e) large vessels and extensive glands are situated. Within these branches of the posterior jaw is lodged the throat, and it will be observed how necessary it is that these branches should expand sufficiently to admit of the motions of the head, particularly of those influenced by the reining-in of the bridle; otherwise the blood vessels and other parts must be injuriously pressed upon.

5585. *The hollow between the jaws* is called the channel, and at the under part of it (f) a considerable branch of an artery proceeds from the inner side over and around the outer, and which branch forms the most convenient situation for feeling the pulse of the horse.

5586. *The face* (g) of the improved breed of horses presents either a straight line, or one slightly curved inwards towards the lower part; whereas in the heavy breeds, it is very commonly found to be curved outward. This part comprises, as with man, from the forehead to the lips. When the face is covered with white, it is considered a blemish; but when a white spot only exists in the forehead, it is considered a beauty.

5587. *The markings in the face are useful to describe a horse by, and frequently lead to the recovery of a strayed or stolen one.* In regimental accounts these marks are carefully noted. When a spot extends down the face, it is termed a blaze; and when further continued into the muzzle, it is called blaze and snip. When a star is distinct, but with it there are white markings which begin some distance below it, and are continued downwards, it is called a race.

5588. *The muzzle (h h) includes the lips, mouth, and nostrils; the darker the colour of this part the more is the horse esteemed: very dark brown horses are an exception, for in them it is usually of a tan color, and is praised both as a beauty and indicative of excellence.*

5589. *The lips should be thin, firm, and by no means loose and pendulous, as is the case in very old or very sluggish horses.*

5590. *The form of the mouth, as receiving the bit, is important.* It is also of more consequence than is usually supposed, that the commissure or opening of the mouth be sufficiently deep; when shallow, it is not only inelegant, but it will not admit a bridle favorably into its proper resting place upon the bars. Within the mouth are situated the teeth, which are so placed as to have interrupted portions of jaw above and below of considerable extent. These vacancies are called *bars*, and are parts of extreme importance to the horseman, as it is by means of agents called bits resting on these parts, and operating on their sensibility by means of a lever, the long arm of which is in the hand of the rider, that he ensures obedience. In aid of this mechanism, to one portion of this lever is attached a chain, called a curb, which acting on the outer part of the chin, increases the pressure. This latter part has been called the *barb* or *beard*, but its situation is evidently above that. In the examination of a horse intended to wear a bitted bridle, it is also of considerable importance that both the bars and barbs should be thin, and not covered with thick fleshy matter which deadens their sensibility. If scars or cicatrices are seen on them, particularly in the bars, being the remains of former injuries, they in a great measure render the mouth insensible, and are greatly against the proper action of the bit: and it is to be observed that a scar on one side is worse than one on both.

5591. *The teeth (fig. 614), which present themselves on the lower parts of the jaws, are the incisive and canine. The two front incisives are popularly called nippers or gatherers (a). The two next adjoining, separators or middle teeth (b), and the outer, the corners (c), but it would be more definite to say the first, second, and third incisives, beginning at the corner. The tusks (d d) occupy part of the intermediate space between the incisive and grinding teeth. The teeth, as criteria of age, will be considered in another place, and as organs of digestion, they will be further noticed in the anatomical detail.*

5592. *The organs of the neck.* The exterior parts which compose the neck are first the upper surface, which is furnished throughout its whole extent with an elegant assemblage of hair called mane (e e). In some instances, as in stallions, it is of enormous length and thickness. In a cream-colored one exhibited some years ago, it was so long as to be suspended in a bag. Nature appears particularly to have studied the beauty of the animal by this gift; had it been designed as a guard, it would have grown on both sides: whereas when not altered by art, as in cavalry horses, it naturally hangs to one side only. In dark colored horses it is commonly black, but in horses of colors approaching to a light hue, the reverse is frequently seen, and the mane and tail are in these often lighter than the body.

5593. *To make the hairs of the mane and tail lie smooth* is an object with most horsemen, but the pulling the hair out in tufts by wrapping it round the fingers is a most erroneous practice, and not only at the time frustrates the end intended, but a mane so pulled, will seldom hang well after. The writer of this has always made use of a three-pronged angular mane puller, which, if used two or three times a week, will bring both mane and tail into perfect order, and will keep them so. This iron is manufactured and sold by Long, veterinary instrument maker in Holborn, London.

5594. *The upper surface of the neck (i) should form a moderate but elegant curve, which is greatly favorable to beauty: this curve is however not so considerable in the pure eastern variety as in the better sort of northern horse.*

5595. *The under surface of the neck (k k) should be nearly straight; in the cock throated horse it arches outwards, and the upper surface in these instances is sometimes hollowed inwards in equal proportions, when such horse is called ewe-necked.* When this deformity is considerable, it prevents the head from being carried in its true angle, and particularly so under the action of the bridle; in which cases the nose being projected forwards carries the axis of the eyes upwards, such horses are called star gazers; and it is to be observed that they are seldom safe goers. In mares and geldings a very just criterion of a sluggish disposition, may be formed from the presence of a considerable quantity of flesh on the upper surface of the neck: when the crest is very thick and heavy, it is almost an unerring prognostic of a decided sluggard. In stallions it however forms a distinctive sexual mark, and therefore is less to be depended upon in them. In a well proportioned horse, the length of the neck, the length of the head, and of the angle uniting the two, should give the height of the withers from the ground. When the neck is too long, the head must of course gravitate by the increased length of the arm of the balance; it likewise seldom presents a firm or proper resistance to the bridle. When on the contrary the neck is too short, the head is frequently ill placed, and the lever in the hand of the rider will be too short also.

5596. *The organs of the trunk or carcase are various.* Considered as a whole, Clark has not unaptly likened it, when separated from the limbs, to a boat; within which are disposed various important viscera. The bony ribs he likens to the wooden ones encompassing the vessel, and the sternum or breast bone, being perpendicularly deep and thin, carries the resemblance further, and fits the machine to cleave the air as the boat does the water. Within this animal vessel, according with the justest mechanical principles, the weightiest of the viscera, the liver is placed in the centre, and the others follow nearly in the relative order of their gravity; so that the lungs, the lightest of the whole, are stowed in front, where great weight would have been most disadvantageous.

5597. *The shoulders (a a, b b) are commonly considered as extending from the withers above to the point in front, and to the line behind formed from the elbow upwards: but a correct description considers them as those parts immediately concerned in motion; that is, of the scapula or blade-bone, and its attachments. The shoulders are too apt to be confounded with the withers above, and with the arm below, erroneously called the point of the shoulders. From this confusion, great error is committed in appreciating their nature and action; but this is removed by recourse to the skeleton (fig. 615 i, k, l). The withers (e e) may be justly proportioned at the same time that the shoulders are narrow, straight, and altogether badly formed, and vice versa. The shoulders should be muscular and narrow, but not heavy; and to determine between these essential points, requires the eye of experience in the viewer, and the presence of condition in the viewed. A muscular shoulder is essentially necessary, when we consider that*



the fore extremities are wholly connected by muscle, and not as in man, by the intervention of the bony union of the clavicle or collar bone. In the horse, therefore, we find that large muscular masses unite the shoulder blade, by its upper and inner surfaces, to the chest; while other powerful muscles suspend as it were the machine between them. By this contrivance, elasticity is preserved and strength gained; for had the shoulders possessed a bony connection, when the body is propelled forwards, its weight and force being received by the fore extremities, painful and hurtful shocks would have been experienced at every step. Powerful muscles for the shoulders are also as necessary for progression as for attachment; but here strength is not alone all that is wanted, just proportion and proper situation are also requisite.

5598. *The centre of action in the shoulders (c)* is in their common centre, and the extent of action of any part moving on its centre, is dependent on the length of such part; the motion the shoulder enjoys is confined to the perpendicular backwards, and to as great an elevation of the muscles as they will admit of forwards. It will be therefore evident that the more oblique is the situation of the shoulder blade, the greater number of degrees it can go through; it must be as evident also that when the shoulder blade is long and deep, as well as oblique, that this advantage is increased. It is commonly observed, although it is not invariably the case, that when the shoulder is short, it is also upright (*b b*). Obliquity and length in the shoulder favor the safety of the progression also, for as the angles formed between the shoulder, the arm, and fore arm, are consentaneous, and make, when in action, a bony arch; so the obliquity and length of the shoulders is favorable to a due elevation of the limb, on which, in a great degree, depends the safety of progression. Thus mares are, *ceteris paribus*, more unsafe than horses, their shoulders being short to correspond with the low mare-like forehead; and their decreased obliquity usually regulates an increased obliquity in the whole limb downwards, or, as is familiarly expressed, they stand with their legs under them. Unfavorable as is this form of the mare, both for the speed and safety of their action, it was given for purposes advantageous to the animal: for, by such a position in the fore extremities, the hinder are raised higher to afford additional security against the evils of gravitation, and dislodgement of the foal from the pelvis. Few rules can be laid down in the exterior conformation that are more important, or of such general application, as that a short and upright shoulder, particularly when united with an inclined direction of the whole limb backwards, is a sure mark of an unsafe goer, and commonly, though not invariably, of a slow one also. It now and then happens indeed, that horses having defective shoulders, prove speedy and good movers, which would appear to contravene these principles; but it will be found, that wherever horses, having these defects in their fore parts, are yet good, it, in every instance happens that, in them, the hinder parts are particularly and unusually strong and well placed, which serves to make up the deficiency. Indeed, it appears probable, that the hind and fore parts do not bear the same relative proportion in all horses alike; in blood horses, the withers are not always high, and although their shoulders are commonly deep and oblique, yet the fore limbs are altogether short in proportion to the hinder, in a great number of the fleetest racers: for, as speed appears to be a principal end in their formation, and as comparative anatomy furnishes us with abundant proof that all animals destined to make considerable leaps, which is, in fact, speed, are low before; the end of their formation is really best answered by this arrangement of parts; it is also more than probable that although speed in the gallop may be found with a defective forehead, that yet, in the slower paces of the canter, trot, and walk, a justly formed shoulder is more immediately requisite. This subject will be still further elucidated when we treat on the mechanical properties of the skeleton.

5599. *The withers (e e)* are formed by the long transverse processes of the dorsal vertebræ (*y*), and as their use is to serve as levers to muscles, so their length and the height of the withers must be of great advantage, and enable such horses to go high above their ground; for the muscles of the back, acting to greater advantage, elevate the fore parts more forcibly. From this we may also learn that the elevation of the fore parts, or the horse's going above his ground, is not altogether dependant on the motion of the shoulders, nor on the height to which the animal may be inclined to lift his legs; but likewise, on the extent to which the fore half of the machine is altogether elevated by the action of the dorsal and lumbar muscles. When the withers are high, or the forehead well up, as it is termed, it is favorable to the celerity and to the safety of the action; but as these properties are less wanting in the heavy breeds, we find in them a considerable variation of form: in the cart horse, whose heavy forehead is of great service, as he draws by an effort to preserve himself from the tendency his weight gives him to the centre of gravity; so the more weighty and bulky he is before, and the nearer he approximates this centre, the more advantageously he will apply his powers. It is not here intended to be hinted that nature gave him this form purposely to enable him to draw: this indeed would be an argument of necessity; but this form has been judiciously imposed on him by men, by regulation of the sexual intercourse, and by a careful selection of specimens having some of the requisites to propagate from, until at last we have produced the massive weighty animal whose powers astonish as well as benefit us.

5600. *The breast or counter (f f)* is the part between the point of the arms or shoulders, and which should be moderately wide and extended: when it is otherwise, the horse is seldom durable, or even strong, although he may be speedy; neither have the lungs sufficient room for expansion, nor the muscles great extent of attachment; frequently too it accompanies a general flatness of ribs, and want of circular form in the carcase in general; all which, experience has shewn to be necessary to the perfection of the machine. The breast, may however, be too wide; it may also hang over or project beyond the perpendicular of the fore limbs, so as to overweigh the machine: this form, however, though unfavorable to the saddle horse, for the reasons just assigned, is much desired in the heavy draught horse.

5601. *The back.* Where the withers end the back commences (*g*); the length should be moderate only, for a long cylinder cannot be so strong as one of less length; long-backed horses are easy because the action and the reaction are considerable; but what is gained in elasticity is lost in strength. When the back is too short, the extremities are so much approximated that they frequently overreach each other; the back should be nearly straight, it has naturally an inclination in the line of its gravity; but this exists in very different degrees in different horses. When the incurvation inwards is considerable, such horses are called saddle-backed, and are usually considered as weak; but to keep up the counterpoise, so the crest in such horses is generally good; they also ride pleasantly, and commonly carry much apparent carcase; sometimes indeed too much. When the back is curved upwards, it is called roach-backed; when considerably so, it is unfavorable to the liberty of action, as well as to the elasticity of motion; and for the reasons given, with too short a back, a horse is often found to overreach: in these cases, to counteract the curve outward, the head is also carried low usually. A short-backed horse is in considerable request with many persons, who do not consider that when it is too much so, there is seldom great speed; for the hinder extremities cannot be brought sufficiently under the body to propel the mass forwards.

5602. *The loins (h)* may be considered as the part which extends from immediately behind the hinder edge of the saddle when properly placed, extending from thence to the rump. Anatomically it begins at the sacrum (*fig. 615 z*), whose processes being sometimes defective or interrupted, leave an indentation, as though the union between the back and loins was incomplete; and such horses are said to be badly loined: but although it may in some measure deprive the muscles of some slight attachments; yet the evil is not so considerable as is imagined. The width of the loins is of considerable import to the strength of the animal, as it affords a greater surface for the attachment of the powerful muscles of the back and loins; and the muscles themselves should be so prominent, as to seem to swallow the back

bone between them. When the protuberances of the ilium or haunch bone are very prominent, the horse is said to be ragged hipped; but it operates to his disadvantage only in appearance, as extent in these parts, being favorable to muscular attachment, is always beneficial.

5603. *The croup* extends from the loins to the setting on of the tail (*n n*). It should be long and only slightly rounded, which is another characteristic of the blood or improved breed. In the cart horse, on the contrary, it is seen short and much more considerably rounded (*n n*). A long croup is in every point of view the most perfect, for it affords a very increased surface for muscular attachment, and although the large buttocks of the cart horse would at first sight convey an idea of great strength and extent, yet attentively viewed, it will be found that the early rounding of the sacral line, the low setting on of the tail, and the small space which necessarily exists between the hips and buttocks, all tend to lessen the surface of muscular attachment, compared with the broad croup, wide haunches, and deep spread thighs of the blood horse.

5604. *The flank* (*k*), is the space contained between the ribs and haunches; when too extensive, it indicates weakness, because it is the consequence of too long a back; and such a horse is said not to be well ribbed up. When the transverse processes of the lumbar vertebrae are short, as in bad joined horses, this part is hollow. The flank is usually looked to also as indicative of the state of respiration: thus, when it rises and falls quicker than ordinary, unless violent exertion has just been used, it betokens present fever, or otherwise, chronic disease of the lungs.

5605. *The belly* (*l*). Having taken a tour round the upper parts of the carcass, we will carry the survey downwards and forwards. Anteriorly, the ribs should be wide upwards, and as much deepened below as possible, which affords what is termed great depth in the girth. This form greatly increases the surface of attachment of the motive organs, the muscles, and also allows room for the free expansion of the lungs, and consequently is favorable to the wind. Posteriorly, the ribs should form the body as much as possible into a circular figure, that being of all others the most extended, and affording the best surface for the absorption of nutriment; thus barrelled horses, as they are termed, are greatly admired. When the chest is too flat and straight, the belly is also small; hence, neither can the blood absorb its vital principle from the air, nor the lacteals the chyliferous juices from the intestines; these horses are therefore seldom durable. As less nutriment is taken up by the constitution, so less is eaten, thus also they are seldom good feeders; and as the pressure on the intestines must be considerable from the small containing surface, so they are usually likewise what is termed washy; that is, easily purged, whereby an additional cause of weakness exists, from the too early passing off of the food. Such horses are, however, very commonly spirited and lively, although not lasting. A knowledge of the advantages gained by a circular form of carcass or belly, as affording the greatest capacity, is what constituted Bakewell's grand secret in the breeding of cattle: he always bred from such animals as would be most likely to produce this form, well knowing that no other would fatten so advantageously.

5606. *The whirlbone* (*l*), among the jockies and grooms, is the articulation of the thigh bone, with the pelvis, or basin, and forms the hip joint. The ligaments of this powerful joint are sometimes extended, and a very obstinate lameness is usually the consequence. Thus the situation of the thigh (*l, m*), is in the horse, as in most quadrupeds, enveloped within the range of the trunk.

5607. *The stifle* (*m*) corresponds with the knee of the human figure, and is the point at the lower portion of the flank. It is evident that the part below this, which is generally called the thigh or gascion, is erroneously so named. It should be very muscular and extended, it should also make a considerable angle with the femur or thigh, and form a direct line under the hip or haunch. Its length in all animals destined for speed is considerable.

5608. *The fore extremities or legs*. In treating on the mechanical properties of the skeleton, we shall have to point out the essential differences between the geometrical structure and functions of the fore and hinder extremities. We shall here content ourselves with a simple examination of the individual parts.

5609. *The arm of the horse* (*b*) is apt to be overlooked, nor, without some consideration, does it strike the observer, that the arm covered with muscles, and enveloped within the common skin of the chest, extends from the elbow (*a*) to the point of the shoulder, as it is termed, but correctly to its own point below and before the shoulder blade (*fig. 615*). The same reasons which render a muscular, oblique, and deep shoulder advantageous, also make it desirable that this part should be muscular and extensive in length and breadth, and that its obliquity should be proportionate to that of the shoulder: from whence it results, that the more acute the angle between them, the greater will be the extent of the motion gained by the flexion and extension of the parts.

5610. *The fore arm* (*c*), which horsemen consider and call the arm, is placed upright to counteract the angular position of the real arm and shoulder bones. As it is always found long in animals destined for great speed, as we witness in the hare and greyhound, it should therefore be of considerable length when speed is a requisite quality; but for the cadences of the manege, where the elasticity is required to be distributed equally through all parts of the limb, it is chosen short. The fore arm is broad and large, particularly upwards, for here the powerful muscles that operate the motions of the parts below, are almost all of them situated. To prevent encumbrance, and to give solidity, these muscles degenerate into tendons and ligaments below the fore arm; but above, it is essentially necessary to strength that they should be large and well marked.

5611. *The knee* (*d*), so called, is properly, with reference to human anatomy, the carpus or wrist. It is composed of many bones to enable it to resist the jar arising from the action of the perpendicular parts above and below it. All the joints of the extremities, but particularly those of the knee and hock, should be broad, that the surface of contact may be increased, and the stability augmented; by this means likewise, a more extensive attachment is afforded to muscles and ligaments; their insertions are also thereby removed farther from the centre of motion.

5612. *As criteria of safe going, the knees should be particularly examined* when it is contemplated to purchase a horse, to see whether the skin has been broken by falls; and in this, very minute attention is required; for sometimes the wound heals so perfectly, or otherwise so much art is used in shaving the hair, blistering, coloring, and rubbing it down, picking out the white or staring hairs, &c., that more than common nicety is required to detect a slight scar. It is, however, prudent to remember, that it is not every horse whose knees betray a scar, that is a stumbler: the best may have a fall in the dark. It is also necessary to caution persons against the admission of a very common prejudice, that when a horse has once been down, however little he may have hurt his knees, he is rendered more liable than before to a similar accident. If his limbs have not been weakened by the accident, or if the scar be not sufficiently large to prevent the free bending of the knee, he is not at all more liable to fall than another horse. If, therefore, a horse with a scar on his knee have the forehead good, and if his action correspond thereto, he ought not to be refused on this ground: but with a different conformation he ought to be steadily rejected, let the tale told be ever so plausible. In gross heavy horses a scabby eruption often seats itself around the inner bend of the knee (*h*), which is called mallenders.

5613. *The canon or shank* (*e*) carries the limb down elegant, light, straight, and strong. Much stress is deservedly laid on the necessity that this part of the limb should be wide when viewed laterally. Viewed in front, its being thin is favorable, because made up as it is principally of bone and tendon, any addition to it beyond these must arise from useless cellular matter, or otherwise from matter worse than useless, being placed there by disease. Any thickening of the part generally or partially, should be

looked on with suspicion; as, if natural, likely to interfere with motion without adding to strength; or if accidental, as a mark of acquired injury likely to remain. In the bony skeleton may be seen within and behind the knee, an apparatus destined to remove the acting ligaments and tendons from the centre of motion, by which great advantage is gained in the strengthening and facilitating their flexions. It is a default in this conformation that renders horses *tied in under the knee*, as it is usually termed, and such horses are the best proof of the truth of the reasoning here offered; for they are invariably found to bear exertion badly; their legs at an early period become bowed or arched, and totter on the slightest exertion. In cart horses this conformation is very common; but in them it is of less consequence than in those destined for quicker motion, where the elevation of the limb is so extensively and so frequently repeated. To render this subject familiarly clear, we will recommend that a cord be placed round the ball of the thumb, and passed up close to the arm until it reaches the bend: with the other hand, by straightening and extending this cord, but held close to the arm, endeavour to flex the hand and wrist inwards: operated in this way it will require great force to do it; but remove the hand only two inches from the arm, and the bound hand will yield readily to a less force. Exactly the same happens to the ligaments and tendons called back sinews which flex or bend the fore legs; for by an apparatus, formed from the position of one of the carpal bones, (*pisiformis*), they are, in well formed legs, set out wide from the knee.

5614. *The back sinews* should not only be large and firm, but they should, like the limb generally, be very distinct from the knee to the fetlock; in this course, if any thickening be observed, it betokens former injury, as extension or rupture of ligamentous fibres, which usually have a disposition to recurring weakness.

If a hard swelling appear on the inner side, not on the tendon, but on the bone, a splint is present which is more or less injurious as it is nearer or farther from the knee, or distinct from or situated among the tendons and ligaments; but when it is considerable in size, hot to the feel, and extends inwards and backwards among them, it usually produces most injurious consequences. To detect these evils the eye alone should not be trusted, particularly where there is much hair on the legs, as on cart horses, and even on hacknies in the winter, but the hand should be deliberately passed down the shank before and behind. An enlargement or scar situated close to and on the inner side of the knee, must not be mistaken for a splint; it more frequently arises from a custom some horses have when trotting fast, of elevating their legs and cutting this part with their shoes, and thence called the *speedy cut*.

5615. *The pastern and fetlock (f.f)*. General usage has applied the term fetlock to the joint itself, and pastern to the part extended from the fetlock to the foot; properly speaking, the fetlock or footlock is only the posterior part of the joint, from whence grows the lock or portion of hair, which, in many horses, flows over and around the hinder part of the foot; a short and upright pastern is inelastic, and such horses are uneasy goers; they are unsafe also, for the pastern being already in so upright a position, requires but little resistance, or only a slight shock, to bring it forwards beyond the perpendicular; and the weight of the machine then forces the animal over. Nor are these the only evils arising from this formation, for the ends of the bones being opposed to each other in nearly a perpendicular direction, receive at each movement a jar or shock, which leads to an early derangement of the joint, and to the appearance called *overshot*. On the contrary, when the pasterns are too long they are frequently too oblique also; and although their elasticity may be pleasant to the rider, such formation detracts from the strength of the limb. These joints both before and behind are very subject to what is called *windgalls*, which are swellings formerly supposed full of air, whence their name; but they are now known to contain an increased quantity of the mucus destined to lubricate the parts in their motions. These puffy elastic tumours are originally small and hidden between the lower end of the canon, and the flexor tendon, or back sinew; but when hard work has inflamed all the parts, the secretion in them becomes increased, and then they become visible to the eye; but unless they are so considerable as to obstruct the due action of the parts, they are no otherwise objectionable than as they tell a tale of inordinate wear of the limbs generally.

5616. *The form of the pasterns influences the defect called cutting*, which arises from a blow given to either the fore or hind fetlocks by one leg to the other during its elevation. Horses narrow in the chest, or which turn their toes out, or have other peculiarities of form, cut permanently, and are then very objectionable; but others only cut when fatigued, or when very low in flesh. Young horses often cut, and when they become furnished, leave it off.

5617. *The feet (g.g)*. These essential and complex organs will be more fully examined in the anatomical detail, but much also presents itself to the consideration in an exterior examination. Horses might be presumed to be naturally born with perfect feet; but experience shows that defects in these organs are hereditary. In some, the peculiarities of climate operate; and in others, a constitutional predisposition exists; dependant on some cause with which we are unacquainted.

5618. *Climate influences the form of the horse's foot*. In the arid plains of the east, where every impediment is removed for an extensive search for food, the feet are hard, dry, and small; this form, notwithstanding the alterations of breed and culture, in some degree still adheres to the blood or aboriginal eastern horse: artificial habits have extended the evil, and now small and contracted feet are to be seen in every variety, excepting in the coarse heavy breeds.

5619. *Constitutional and hereditary causes operate on the feet*. That a constitutional predisposition exists in the production of a particular form of foot, we know from the fact, that dark chestnut horses are more prone to contraction of the hoofs than any other colored horse: and that the form of the foot is hereditary, may be gained from the known circumstance that some of the Lincolnshire stallions always get large flat-footed progeny; while some full bred entire horses entail small upright feet on all their offspring.

5620. *Local situation will also affect the form of the feet*. The effect of situation is remarkably exemplified in the horses which we used to obtain from Lincolnshire, Cambridgeshire, and some parts of Norfolk and Yorkshire, before the draining system was perfected. These horses had, almost invariably, large, flat, heavy feet; which however convenient and natural they might prove to the animals while moving on the quaggy surface of marshy districts, yet were found very unfit for quick, light movements in drier situations. Such horses go heavily and stumble; and as the horn of which these enormous feet are formed, is always weak, the anterior or front part yields to the heat and inflammation brought on by exercise on hard roads, and falls inwards, which letting the weight of the body fall on the soles pushes that downward; and at last from a concave, it presents a convex surface. The feet cannot then bear shoeing, but with much art and difficulty: pain and tenderness bring on lameness and uselessness; and therefore horses with such feet should be rejected. Feet preternaturally small, are equally objectionable, as betokening a disposition to contraction. Horses with a tendency to foundered feet stand with pain in the stable, first placing one foot before, and then shifting it to place the other in the same situation. The contraction usually begins in the heels, which are found higher than natural, and drawn inwards; the foot altogether is likewise narrower, and the sole hard and hollow. When a preternatural fulness is seen around the coronets, *ring-bone* may be suspected; and if heat and hardness be accompanied with any tenderness in going, its existence is certain. But although too much horn is to be avoided, too little produces a weak foot; in which the heels, quarters, and soles all participate: the thin horn cannot resist the impressions of the stones on the road, and then lameness ensues. The under surface of the foot should exhibit a full healthy wide frog with bars prominent and properly infected. The concavity of the sole should be particularly attended to; when less than natural, it is weak, when more, it indicates contraction; from whence such feet have been called too strong. White feet are objectionable, because they are found more liable to this evil than others. *Corns* are an evil to which the under surface of the foot is liable, and which should always be looked for on the purchase or examination of a horse; for which purpose, it would be well that the fore shoes should be removed, and the foot carefully pared

by a judicious or clever smith. Merely picking out the foot will often, also, detect the remains of former cuttings or parings out of the corns. Some hoofs are very brittle, and a horse with this defect should, in every instance, be rejected. The evil may in general be easily detected by the marks of the fragile parts detaching themselves from every old nail hole. This kind of foot, particularly in hot weather, breaks away till there is no room for the nails to hold; when the horse of course becomes useless. *Sanderacks* are also another evil to which the feet are liable; and which should engage the attention in the examination of a horse: they consist of longitudinal fissures; one only is usually present at once; but that one if deep is fully equal to produce lameness. The subject of the feet will be concluded by an observation on their general appearance, well worthy of attention. The eye should be directed to the degree and to the manner in which the shoes are worn; which will often save much useless trouble in trying a horse. A stumbling horse may be frequently, nay, commonly detected by simply lifting up one fore foot: for the unequal wearing away of the shoe at the toe, while the other parts remain good, is a full proof of his going unsafely and *digging his toes*.

5621. On a review of the conformation of the fore extremities, it may be remarked, that whereas the hinder may be considered as more particularly concerned in impelling the machine forwards with its requisite velocity; yet, that upon a proper form and a true direction of the various component parts of the fore limbs must depend the stability, the truth, and the safety of the movements. Viewed anteriorly, the fore legs should stand rather widest at the upper part, inclining a little inwards below; but when we view them latterly, they should present a perpendicular from the arm downwards; and the toe should place itself directly under the point of the shoulder, as it is called. If the foot should stand beyond this, which is seldom the case, the action will be confined, for the limb will have already passed over a point of its ground; such a horse, however, generally treads even, flat, and safe; and, in proportion as it stands in the direct line downwards, he generally inherits these desirable properties. When the foot stands behind the perpendicular line, the defect is considerable, by the removal of the centre of gravity too much forward, by which an increased tendency to stumble and fall is entailed; and as the fact in general accompanies a want of extent and obliquity in the shoulder, so it likewise lessens the speed.

5622. *The hinder extremities.* We have already described the thigh, correctly so called, which is so concealed by muscles as frequently to escape this consideration of it, by which the part immediately below it popularly receives the name of thigh, but is, in fact, the leg.

5623. *The leg* (1, 2), commonly called *the thigh*, in well formed horses is powerfully furnished with muscles, and very extended in its figure; it should also make a considerable angle with the femur or real thigh, and form a direct line under the hip or haunch; for the same reasons that make it desirable to have a long arm in the fore extremities, it is also advantageous that the leg should be so likewise, and which is the form usual among all quadrupeds of speed.

5624. *The hock* (2) is the important joint immediately below the leg, or thigh commonly called, and is interposed between the tibia and tarsal bones (*fig. 615*), purposely to increase the extent of attachment, and to break the shock of great exertion; it may be considered as the most complex and important joint of the body: like the knee, it should be extended and broad; for, in proportion as the calcaneum or point of the hock (5), and which is the real heel, extends itself beyond the other bones; so the powerful *tendo achilles* inserted into it, acts with a longer lever, and with a greater increase of power. This joint is subject to several important diseases, which in the examination of a horse, require particular attention; when a soft puffy swelling is discovered in the ply or bend of the hock (3), it is termed a *blood spavin*, which will be noticed among the diseases; it is, in fact, a similar enlargement with the windgalls before mentioned, and what has been said on them equally applies to these. When similar mucous capsules become enlarged on each side of the hock, the enlargement receives the name of *thorough-pin*. A small bursal enlargement is sometimes found at the very point of the hock (5), and is then called a *capulet*; to all which, what has been said on wind galls, applies, that they are only to be deemed of consequence when so large as to interfere with the motion of the parts they are situated with, or near; or, as indicative of an undue portion of work. The ligaments at the back of the hock sometimes become strained or extended, and heat, inflammation, and swelling follow, which is then called a *curb*. As rest or very mild treatment soon reduces it, it is not to be considered as of great consequence. The inner part of the joint at the ply or bend, is sometimes attended with a skin affection similar to the mallenders before alluded to, and is called *scallenders* (4); but the most serious disease to which the hock is liable, is a disease of the ligaments of some of the dorsal bones. Sometimes one or more of these bones take on *spavin*: to detect the existence of this affection, the hocks should be attentively viewed from behind, when any enlargement in the spavin place (3, 4) may be easily detected. The mechanism of this joint will be further considered when we treat of the skeleton generally.

5625. *The color of horses* does not depend on their real skin as with man, but upon an exterior beautiful covering which nature has given them, called *hair*; nevertheless, the hair is, in some measure, influenced by the skin, as light skinned horses have light hair, and when the hair is light, the eyes are usually so likewise: hair presents many varieties of tint, so horses are said to be of various colors. Buffon has conjectured that horses were originally of one color, which he presumes to be bay; but such wild horses as have been seen, and which have been supposed to be pure originals, have not justified this opinion. This same author has divided the colors of the horse into simple, compound, and strange or extraordinary.

5626. *The simple colors* are bay, chestnut, dun, sorrel, white, and black; bay is a very prevailing tint among European horses, and admits of many shades, but is admired in all: there are bright bays, blood bays, dark and dappled bays; *brown bay* is a very esteemed color, and consists of bay and black in unequal proportions in different horses: *brown* horses are highly prized; the darker varieties have usually beautiful tan markings, as about the muzzle, &c: they have commonly also black manes and tails, with legs and feet of the same hue; and it may be here remarked, that horses of compounded colors, of whatsoever tint the mane and tail may be, will be found invariably formed of one of the compounding colors; thus light greys, which are a compound of black and white, have often white manes and tails: sorrels, again, which are formed of white, with a small proportion of red, have also frequently white manes and tails: *chestnut*, which is also a very common color, admits of almost as many shades as the bay, from the lightest tint to the deepest tone. Very light chestnuts have frequently still lighter manes and tails, with mealy legs and light feet; so marked, they are certainly not to be chosen for strength, durability, or pliancy of temper: the *suffolk punch*, however, may be considered in some degree an exception, although the true breed are hardly so light as those hinted at here. Dark chestnuts are considered, and with justice, as fiery in their dispositions; they are also more subject to contracted feet than horses of any other hue. *Dun* is a color that has several varieties; it is sometimes accompanied with a white mane and tail, at others they are seen even darker than the rest of the hair. In some, a list or line of deeper tint extends along the back, which is regarded by some as an indication of hardihood: it

similar line is sometimes seen in the bay. Dun horses do not appear to be at all influenced in their qualities by their color, or rather, no criteria are offered by it, for there are good, bad, and indifferent in all the varieties of shade. The *sorrel* is a variety of the chestnut, but not a favorite one. *White*, as a native color, is not in much estimation, neither is it very common, for many horses are white only through age, as all light-grey, and flea-bitten horses become so. *Black* is a very usual color, and in the large heavy northern breed, it seems to be an original tint; and, perhaps it is to this their godness may be attributed, for, among the lighter breeds, there are more indifferent black horses than of any other color. The tempers of black horses are commonly in the extreme, either sluggish to stupidity, or fiery to excess. The color itself admits of many shades; but a perfect black horse is more unusual than it is generally thought to be: a star in the forehead is common to relieve the ebony hue; and in the absence of that, a few white hairs on the breast frequently interrupts the uniformity. It is perhaps on this principle that black horses have white legs so often as they do.

5627. *The compound colors* may be considered as those in which the hairs are compounded, but not the colors themselves; otherwise the bay, the chestnut, brown, &c. might be considered as compounded colors. The *roan* is a mixture of red and white: its varieties are the common, the red, and the dark. All the roans are esteemed. *Grey* admits of a great number of shades and varieties, but all are compounded of black and white, except the iron grey, which receives a few bay hairs among the black and white; a considerable prejudice exists in favour of this colour. Greys are light or dark; there are also the dappled, the markings of which are extremely beautiful, and the silver grey. Grey horses become lighter by age: many old white horses have been grey until age overtook them. Grey horses, like black, admit of no settled character; though unlike them, they are not to be generally disapproved of. They have, however, all the extremes within their range; the darker ones are usually good, the lighter ones not generally so.

5628. *The extraordinary colors* are not very numerous, and it may be remarked, that white is always the relieving tint, intermixed with distinct markings, in various proportions, of bay, brown, black, or chestnut. *Flea-bitten* is grey or white, with small bay spots. When these spots are very large, and have a marginal surface of lighter markings, they give the name *tiger colored*; and although they are uncommon with us, they are not unfrequent in Germany and Barbary. *Pied* or *pie-bald* is one of the most numerous extraordinary colors, and is usually composed of two colors, in distinct large markings. Now and then a third interferes: there are pies of all original colours with white, and all are held in estimation.

5629. *Color, as a criterion of mental and personal qualities*, is laid much stress on by many persons; and notwithstanding the adage, that "a good horse cannot be of a bad color," long experience has shown that in general cases, certain tints are usually accompanied by certain qualities of person or disposition. As a general rule, dark coloured horses are certainly the best; but as before observed, it is peculiar that black, as the darkest of all, should form an exception to this rule. Light shades appear unfavorable to strength and durability; they are also accompanied frequently with irritability, and perverseness of temper. Something like a general law in the animal economy seems to prevail, to make white a distinctive mark of weakness. Age, which is the parent of weakness, brings with it white hairs, both in man and in horses, and most other quadrupeds. The hair formed after a wound has robbed a part of its original covering, is often white, because the new formed surface is yet in a state of debility. It is likewise a fact well known among the observant, that the legs and feet when white, are more obnoxious to disease than those of a darker tone. The Arabs remark, that light chestnut horses have soft tender feet. It is the observance of these peculiarities, that has at length guided our taste, and formed our judgment of beauty. With us much white on the legs is considered as a deformity, and is expressively called *foul marked*, whereas pied markings in other parts are reckoned beautiful. In Africa, however, Captain Lyon informs us a superstitious dependance is placed on horses with legs and feet stockened with white. It does not appear that climate has the same influence on the color of horses, as on other domesticated animals. In all latitudes in which the horse can live, he is black or white indiscriminately; but as he cannot endure extreme rigour, it is not necessary he should vary.

### SECT. III. *The Anatomy or Osseous Structure of the Horse.*

5630. All quadrupeds are formed on an earthy base called bone, and the assemblage of bony parts is called a skeleton. Bones are formed of earth and membrane (1844); they are covered also by an investiture called periosteum. The earthy part is the last formed, and consolidates the bones as the animal becomes fitted to exert all his powers. This deposit of earth in the bones appears to be hastened by any thing that permanently quickens the circulation: heat does this, and hence the human and brute inhabitants of warm climates come to perfection sooner than those of northern regions; but they are generally smaller, for by preternaturally hastening the earthy deposit before the membranous part of the bones becomes fully evolved or grown, they will not attain the bulk they are capable of. Undue exertion has the same effect, and thus we learn why horses too early and too hard worked become stunted in their growth. Pressure likewise occasions an early, and also a preternatural ossification: in this way the parts of the spine which bear heavy loads, present large masses of bone, brought on by this cause alone. For the same reasons, horses early worked put out splints, spavins, and other bony concretions. Bones are all of them, more or less, hollow: within their caverns an oily fluid is secreted, called medulla or marrow, which serves for their support, and of the constitution generally. The bones have nerves, blood vessels, and absorbents. Bones are capable of reproduction, as is proved by their uniting when broken; and also by the yearly renewal of the antlers of the deer, which are not horn as in the ox or sheep, but pure bone. Bones are connected together by *articulation*: when such articulation is moveable, it is termed a joint. In some cases bones articulate by suture or indentation of parts, as in the skull. We shall consider, in succession, the anatomy of the head, trunk, and extremities.

#### SUBJECT. 1. *Anatomy of the Head.*

5631. *The bones of the head* are the *occipital*, (fig. 615 between *a* & *b*) which is the largest bone of the skull: in the colt it is composed of several pieces which unite by age, by two apophyses; it articulates with the atlas (*a*) or first of the cervical or neck vertebrae. At its posterior surface it is perforated by a large hole, which gives passage to the spinal marrow. The two *frontal* bones (*b*) unite also by age;



behind them is lodged the anterior and inferior portion of the brain. A division of their bony surfaces forms two cavities called the frontal sinuses, which are lined by the nasal or smelling membrane

615

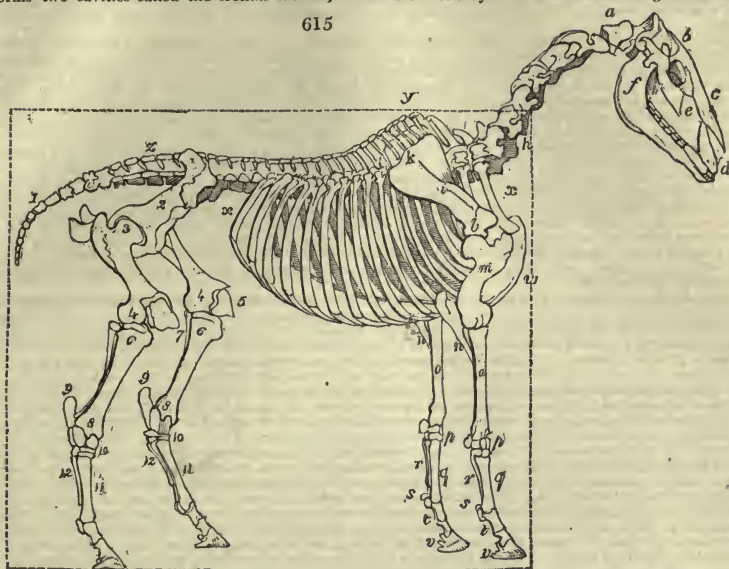

throughout. The union of these two bones is by means of the sagittal suture. The remainder of the bones of the skull are the *two parietals*, the *two temporals*, divided into a squamous and petrous portion, within the latter of which is situated the internal ear; and to the former the posterior or lower jaw articulates. The *sphenoid* and *ethmoid* bones are hollow and irregular, serving to intersect and attach the others; and also to assist by their cavities in extending the pituitary or smelling membrane.

5632. *The bones of the face* are ten pairs and two single bones. The *nasal* (c) pair within their union, hold the septum narium or long cartilaginous plate which separates one nostril from the other. These bones also greatly assist to extend the surface of the smelling organ. In the old heavy breeds, it was very common to see these bones arched outwards; but in the improved breed, particularly in those approaching full blood, it is not uncommon to find them slightly curved inward. The fossæ within these bones are the principal seat of glands. The two *angulars* form a considerable portion of the orbits of the eyes. The two *malar, jugal, or cheek* bones occupy also a portion of the orbits. The *superior maxillary bones* (c) are the largest of the face bones, and contain all the upper molar teeth. The *inferior or intermaxillary bones* (d) are wanting in man, in whom the face is short: these bones concur with the former in forming alveoli or sockets for lodging the teeth. The *superior palatines*, the *inferior palatines*, the *pterygoids*, the two *anterior*, and the two *posterior turbinated* bones, with the *vomer or plough share*, make up the remaining facial bones, with the exception of the *posterior maxillary or lower jaw bone* (f), which on its anterior edge is pierced to lodge the teeth; at the upper part it extends itself into two angular branches, each of which ends in two processes, and an intermediate groove. The most superior of these processes articulates with the upper jaw. This bone throughout shows the most admirable mechanism; the molar or grinding teeth, on whom most is dependent, and whose exertions are greatest, are placed near the centre of motion; and as the upper jaw in most animals is fixed, or nearly so, it was necessary that the lower should have considerable extent of motion for the purpose of grinding; and it is accordingly so formed as to admit of motion in every direction. The *os hyoides* is a bone situated within the head at the root of the tongue, to which it serves as a support, and for the attachment of muscles.

5633. *The teeth* of the horse are the hardest and most compact bones of the body. There are usually forty of them in the horse, and there are thirty-six in the mare; in which latter, the tushes are usually wanting. In anatomical language, they are divided into *incisores, cuspidati, and molares*, or according to the language of farriers and horsemen, into twelve *nippers* (fig. 614 a, b, c), four *tushes* (d, d), and twenty-four *grinders*, which numbers are equally divided between the two jaws. The teeth are received into indentations or sockets between the bony plates of the jaw, called alveoli, by cone like roots. The bodies of the teeth are principally composed of two substances, one of the nature of common bone, giving bulk and form, and one of extreme hardness, placed in man and carnivorous animals, wholly without the teeth to give strength and durability; but in the horse and other granivore, the latter particularly, is placed in the grinders, in perpendicular plates, within the body of the teeth; by which contrivance, a rough grinding surface is kept up; for the mere bony parts wearing faster than the lamellæ of enamel, it follows that ridges remain to triturate the vegetable matter that passes between the teeth.

5634. There are *two sets of teeth*, a temporary or milk set, and a permanent or adult set, in which wise provision, man and most brutes participate. The milk set are some of them, as the molars, apparent at birth; there being usually six grinders in each jaw, three on each side in the new born foal, and which number of this set is never increased. The nippers begin to appear soon after birth, and follow a regular order of succession until the animal is three or four months old; at which time he begins to require support from herbage as well as milk. The temporary set, remove gradually one after another; had they all been displaced at the same time, or even had several of them fallen out together, the animal must have suffered great inconvenience, and perhaps have been starved. This removal, which commences at the age of two years and a half, and is completed between the fourth and fifth year, is effected by the action of the absorbents on their fangs, and appears to be occasioned by the stimulus of the pressure received from the growing teeth under them. For although these two sets appear with an interval of some years between them; yet the rudiments of both are formed at nearly the same period, and both sets may be thus seen in a dissected jaw. Regulated by the stimulus of necessity, as soon as the temporary set falls out, the permanent appears: and that such appearance follows the necessity is evident; for a premature or accidental removal of the colts teeth is soon followed by the appearance of the others.

Dealers and breeders aware of this, draw the milk teeth to make their colts appear as horses. It was necessary there should be two sets of teeth, for as they grow slowly in proportion to the jaws; so had there been but one only, the disproportion of growth between the teeth and jaws must have separated them.

5635. *The forms of the teeth vary more than their structure.* The incisive or nippers are round, which is favorable for the pressure they undergo; the upper more so than the lower. On the upper surface a hollow is seen in the young tooth, which, not extending through the whole substance, naturally wears out with the wear of the tooth; and as a considerable degree of regularity occurs in this wearing away in all horses, it has gradually settled into the general criterion of age. The nippers are not all of them exactly similar; the corner teeth differ most in being nearly triangular, and in having an internal wall or side, which does not become level with the rest until long after the others. The cuspidate tusks or tusches are permanent, appearing at about five years or rather earlier; those in the front jaw are usually nearer the nippers than those below. Each presents a slight curve, which follows the direction of all the canine or pugnatory teeth of other mammalia. The pointed extremity wears away by age, leaving merely a buttoned process, which may serve as a guide to the age when a horse is suspected to be bishoped, as it is called, from a man of that name who was peculiarly dexterous in imitating on old teeth the distinctive cavity of youth. The molar or grinding teeth are stronger in the upper than in the lower jaw; which was necessary, as they form the fixed point in the process of grinding. The upper surface presents nearly a long square, indented from the alteration of the enamel with the bony portions; and as the interior or upper teeth hang over the posterior, so the ridges of the one set are received into the depressions of the other.

5636. *Wear of the teeth.* The teeth, in a state of nature, would probably present a surface opposed to each other for mastication, to the latest period of the most protracted life; but the removal of the animal from moist food to that which is hard and dry, must occasion an unnatural wear in those organs; and hence, although the teeth of the horse, even in a domesticated state, are not subject to the caries of the human; yet the grinders are liable to become thus injured by continued exertion. In the young or adult horse, the upper and under grinders do not meet each other horizontally; on the contrary, they have naturally an inclination obliquely inwards; and those of the upper jaw present small spaces between each other, while those of the lower are more continuous: by which means as the food, but particularly as interrupted portions, as grain, become ground, they fall within the mouth to be replaced under the grinding surface, if necessary, by the joint action of the tongue and muscles of the cheek. This arrangement becomes in a great measure frustrated in old horses, by the superior wear of the inner surface of the upper grinders, as well as by the general misapplication of the surfaces of both upper and under teeth, by constant attrition when worn down to the gums nearly. The unfortunate animal feels sensible of this, and endeavours to remedy it by throwing the wear on the outer edge, by an inclination of the lower jaw and of the head in general; and which is so particular in its appearance as to engage the attention of the by-standers. This defect may be in a considerable degree remedied by casting the animal, and having opened and wedged the mouth so as to keep it so, with a well-tempered concave file, to remove the inequality as much as may be. When the defect is considerable, and the horse is mild and quiet, it is better to file the inequalities every day, which will gradually but effectually wear them down. It however happens, that the inclination thus to wear is commonly resumed, and gradually the same loss of nutriment takes place: in which case, soft moist food, as carrots, mashes, soiling, or grazing, must be substituted for harder substances, and if corn be actually necessary, let it be bruised. Whenever an old horse betrays symptoms of want of condition, or weakness and emaciation, that neither his mode of feeding, nor his ratio of work will account for, and particularly if whole grains should be found in his dung, his teeth should be examined carefully. This undue wearing of the teeth occasions another evil often, which is ulceration of the cheeks, by reason of the projecting ragged surface of the uneven teeth, which can only be remedied by the removal of such portions. These projecting portions are called by farriers *wolves' teeth*.

#### SUBJECT. 2. *The Anatomy of the Trunk.*

5637. *The trunk of the skeleton consists of the spine, the pelvis, and the thorax or chest, composed of the ribs and sternum.*

5638. *The bony column called the spine, is made up of seven cervical, eighteen dorsal, six lumbar, and five sacral vertebræ, with the addition of thirteen or fourteen small tail-bones.* The spinal bones are thus divided on account of the varieties they present; they have, however, some characteristics in common. Each is composed of a spongy bony body, with protruded points called processes, which processes unite to form a hollow through which the spinal marrow is transmitted; and by some of these processes the vertebræ are articulated with each other, as well as by their bodies, by which their strength as a column is much increased. Though but little motion exists between any two vertebræ, yet the flexibility of the whole spine is considerable.

5639. *The cervical or neck vertebræ (g, h), are called by farriers and butchers, the rack bones.* It is remarkable that, let the neck be long or short, the number of bones is the same in most quadrupeds. The first and second differ from the rest in figure, and present some other peculiarities. The first is the only one of them to which the great suspensory ligament of the neck does not attach itself, which would have interfered with freedom of motion. It articulates with the second by receiving its tubercular process within it, and from which process the second of these bones has been called *dentata*. Between these two neck bones is situated a part, where the spinal marrow is exposed from any bony covering; at which part butchers plunge a pointed knife into what they call the pith of the neck, when they want to kill their animals instantaneously, and without effusion of blood; from whence it is called pithing. The remaining five neck bones are not very dissimilar from each other.

5640. *The dorsal vertebræ (y) are now and then, though rarely, nineteen in number; they do not differ materially from each other, but in the length of the spinous processes of the first seven or eight. It is to these elongated spines that we owe the height of the withers, and as the intention of these parts seems principally to serve as levers for the muscles of the back inserted into them; so we can readily understand why their increased or diminished height is favorable or unfavorable to progression.* These like the former articulate with each other by processes as well as by the anterior and posterior surfaces of their bodies; between each of which is interposed a substance semi-cartilaginous in its structure, which is most compressible at its sides, these permitting the motion of the spine.

5641. *The six lumbar vertebræ differ from the foregoing in having a longer body, and very long transverse processes to make up for the deficiency of ribs in the loins.* These bones often unite by the pressure of heavy weights, and sometimes spontaneously by age, and thus we need not be surprised at the stiffness with which some old horses rise when down.

5642. *The five sacral vertebræ (z) are united into one to give strength to the column, and to serve as a fixed support to the pelvis, or basin, with which it is interwoven.* From this detail it will appear how admirably this spinal column is adapted to its important functions of serving as a flexible but powerful support to the machine; and how by the formation of a large foramen within the substance of each vertebræ, a bony canal is offered for the safeguard of the spinal marrow, from which, through lateral openings in these vertebræ the spinal nerves are given off in pairs. *The pelvis or basin (2)* is composed of the sacrum, the two ossa innominata and coccygis. *The ossa innominata* in the foetal colt before birth are each composed of the ilium, the ischium, and the pubis, before birth all traces of this division are

lost. The *ilium* is the most considerable, and forms the haunches by a large unequal protuberance which, when very prominent, occasions the horse to be called ragged hipped. The next largest portion is the *ischium* or *hip bone*, on each side. It forms a part of the cotyloid cavity, or hollow for the thigh bone, and then stretches back also into a tuberosity which forms the points of the buttocks. The *tubis* or *share bone* is the least of the three: in conjunction with the former it forms the *acetabulum* or cavity in which the head of the thigh-bone lodges. The pelvis or basin is attached to the sacrum by ligaments of immense strength; but it has no bony union, by which means, as in the fore extremities, some play is given, and the jar of pure bony connection is avoided. The *ossa coccygis*, or bones of the tail, vary from eight to sixteen, but are very commonly thirteen or fourteen.

5643. The *thorax* or *chest* comprises the sternum or breast bone, and the ribs. The *sternum* (*w*) of the horse is inclined like the keel of a ship to which the ribs are attached by strong ties. The *ribs* (*x x*) are usually eighteen to each side, of which eight articulate with the sternum, and are called *true*, while the remaining ten, uniting together by intervening cartilages, are called *false ribs*. The centrals are the longest, those more anteriorly as well as posteriorly are less so: the first is placed perpendicularly, the second less so, and their obliquity as well as dimensions increase as they advance, so as to enlarge the chest to an almost circular form, which is the most desirable; but when they are less arched, the belly partakes of the defect, and a flat-sided horse is always without much carcass also.

### SUBJECT. 3. *The Anatomy of the Extremities.*

5644. *An examination of the bony parts of the limbs* excites our admiration at the wonderful mechanism displayed in their formation: but this is not all, they must be regarded as presenting parts which appear less useful than intended to keep up that vast chain of continuity and similarity observable throughout nature's works. In the following explanation we shall have occasion to notice several of these.

5645. The *scapula* or *shoulder blade* presents itself first (*k, l*), and is a broad and rather triangular bone very unlike the same bone of the human figure, having neither acromion, coracoid, nor recurrent process: neither is its situation at all similar to the human blade bone applied to the back; for in this instance the horse may be said to have no proper back, but to be made up of sides and chest. In man, the scapula is in a direct angle with the humerus, but in the horse it does not pass out of the plane of the arm. Its superior surface is furnished with a considerable cartilage (*l, m*), by means of which its surface is augmented without weight. The posterior surface ends in a superficial cavity called *glenoid*, which receives the head of the humerus or arm bone. It is divided in its upper surface by its spine. The shoulder blade, as has been already shown in the exterior conformation, has neither bony nor ligamentous union, but is held in its situation by very powerful muscles, as the *serratus major*, *pectorals*, and others. Its usual situation is to a plane perpendicular to the horizon, at an angle of thirty degrees; and it has a motion in its greatest extent of twenty degrees: hence, as it does not pass beyond the perpendicular backwards, so the more oblique its natural situation, the more extensive are its motions.

5646. The *humerus* or *arm bone* (*n*), is so concealed by muscles as to be overlooked by a cursory observer, and hence the *radius* or next bone is popularly called the arm. It extends from what is called the point of the shoulder, but which in fact is a protuberance of its own to the elbow, forming an angle with the scapula, and extending obliquely backwards as that does forwards. Near its upper extremity it sends off a very powerful head to articulate with the shoulder blade. The motions of the humerus are necessarily confined to a removal from its inclined point backward to the perpendicular line of the body. When this bone is too long, it carries the fore legs too much under the animal, and if this defect be joined to a shallow upright shoulder, the evil will be increased. It however fortunately happens that both the angle and extent of these two parts are usually regulated by each other.

5647. The *fore arm* (*n n, o o*) is composed of the *radius* (*o o*), and an appendage united to it, which in man and some animals, forms the *ulna* (*n n*), but which as the leg of the horse requires no rotatory motion was unnecessary in him. Here, however, to keep the link of resemblance in all her children of the higher order, nature has stretched out a large process; which in the colt is really distinct, and may then deserve the name of *ulna*; and in the adult horse unites with the *radius*, and serves as an attachment to muscles. On the slightest inspection of the skeleton, it will appear how much the motions of the fore leg must depend on the length and obliquity of this process; which acting on the principle of a lever in the extension of the arm, must necessarily, as it is either long or short, make all the difference between a long and a short purchase. The breadth of the arm as it is called, at this part, will from this reasoning be seen to be very important. This bone articulates with the knee by its inferior portion.

5648. The *carpus* or *wrist*, called the *knee* (*p p*), is composed of seven bones, whose principal uses appear to be to extend the surface of attachment of ligaments and tendons, and by their interruptions to lessen the shocks of progression. It may be remarked that all hoofed quadrupeds have the anterior extremities permanently in the state of pronation, or with what is called the back of the wrist turned outwards. The carpal bones articulate with each other, and have one investing capsular ligament, by which means the smallest wound of the knee which penetrates this ligament, has the effect of opening the whole joint; hence the quantity of *synovia* or joint oil which escapes in these cases, and hence also the dangerous consequences which ensue.

5649. The *metacarpus* (*q q, r r*), *canon* or *shank*, is formed of one large metacarpal bone (*q*), and two small ones (*r*). Here the wide palm of the human, and the paw of the digitated animal, is formed into one solid cylindrical bone, and two small additamentoræ, called *splint* bones; which are united with it by strong ligamentary attachment, converted by age into a bony one. Although these additions may somewhat increase the surface of attachment, their principal use appears to be to keep up the connection with the digitii, of which they appear the rudiments. In the cow there are no splint bones, but the uniformity is more perfectly kept up by the divided hoof: in her, therefore, the canon branches at its inferior surface into condyles for the reception of the two claws.

5650. The *pastern* (*t t*). The rest of the extremity below the canon, consists of one phalange only, comprising all the mechanism, and a double portion of complexity of all the phalanges of the digitated tribes. Four bones enter into its composition with two small *sesamoids* (*s s*) to each fetlock; placed there not only to act as a spring and prevent concussion, but to throw the tendon of the foot which runs over them, farther from the centre of motion. The pastern bone is situated obliquely forward, and on which obliquity depends the ease and elasticity of the motion of the animal: nevertheless when it is too long, it requires too great efforts in the tendons and ligaments to preserve it in its situation; and thus long jointed horses must be more subject to fatigue and to strains than others.

5651. The *lesser pastern* or *coronary bone* (*l, v*) receives the great pastern, and below expands into a considerable surface articulating with the *coffin* and *navicular* bones.

5652. The *coffin bone* (*v v*) forms the *third phalange*, and corresponds in shape with the hoof. It is very porous, and laterally receives two prominent cartilages. It is around the outer surface of this bone that the sensible laminae are attached; and the inferior surface receives the flexor tendon.

5653. The *navicular nut* or *shuttle bone* is situated at the posterior part of the coffin, and unites with that and the preceding bone.

5654. *The posterior extremities differ much from the anterior, not only in their superior*

strength, and in the different lengths and directions of the parts, but also, in some degree, in their uses.

5655. *The femur or thigh bone* (3, 4) is the largest of the body, its vast indentations and risings, almost peculiar to it, shew the great strength of the muscles inserted into it. It articulates with the acetabulum or hip joint by a strong head called the *whirl-bone*. In this situation it is held not only by a powerful capsular ligament, and still more powerful muscles, but by an admirable contrivance resulting from a ligamentous rope, which springs immediately from the middle of its head, and is firmly fixed within the socket of the joint. In its natural situation it is not perpendicular as the human femur, but inclines to an angle of about 45°. This bone presents large protuberances for the attachment of very powerful muscles called trochanters. Throughout it exhibits a mechanism uniting the combined qualities of celerity and strength unknown to other animals. The inferior end of this bone is received by its condyles into depressions of the tibia, while the patella or knee-pan slides over the anterior portions of both bones.

5656. *The patella* (5), which is by farriers called the stife, is nearly angular, and serves for the insertion of some of the strongest muscles of the thigh, which are then continued down to the leg. It thus appears to act as a pulley.

5657. *The tibia or leg bone* (6, 6) is usually in horsemen's language called the thigh. It is a bone formed of a large epiphysis, with a small attached part called the fibula (7), a long body, and an irregular inferior end, adapted to the peculiarities in shape of the principal bones of the back with which it articulates. The obliquity in the situation of this bone corresponds with that of the femur, being as oblique backwards as the former is forwards. The length of the tibia is a prominent character in all animals of quick progression; and in this respect it corresponds with the fore arm, and the remarks before made on that, apply with even more force to this — that length is advantageous to the celerity, but less so to the ease of the motion.

5658. *The fibula* (7, 7) forms a prominent instance, in common with the splint bones, of what was remarked in the outset of our osteological detail of the extremities — that many parts whose uses were not apparent, would be found to be organs of harmony, placed in the body to prevent the interruption to the completing the general plan of animal organization. In this way the *fibula* appears but a process springing from the posterior part of the tibia, forming but the rudiments of the human bone of that name. In the ox it is wanting; in the dog and cat, as requiring numerous motions in their limbs, it is, on the contrary, perfect.

5659. *The tarsus, or hock of the horse* (10, 10), is a striking instance of the perfect mechanism displayed in the bony structure of this admired animal. It is formed by an assemblage of six bones, and sometimes of seven; while in the ox, sheep, and deer, there are seldom more than five. Between these bones there is little motion, yet there is sufficient to give a spring to the parts, and to preserve the joints from the effects of shocks, &c. As the human anatomy is generally received as the standard of comparison, we must, in order to a proper consideration of the hock, consider it as the instep and heel; and all the parts beyond it as the foot. The human tarsus, and that of some quadrupeds, as the monkey, and some varieties of the bear, makes a right angle with the tibia in standing or walking; but in the horse, the hock makes an open angle with the tibia, and is far removed from the ground. In him and the greater number of quadrupeds, all the bones from the hock downwards are much elongated, and form a part of the upright pillar of the limb. In the horse, therefore, the point of the hock is the true point of the heel, and, as in the human figure, the great twisted tendons of the gastrocnemii muscles are inserted into it: but the appellation of tendo achilles, would be too forced here. A broad hock, as already observed in the exterior confirmation, may be now still more plainly seen to be very important to strength and speed; for the longer the calcaneum or heel bone of the hock, the longer must be the lever that the muscles of the thigh act by; and a very slight increase or diminution in its length must make a very great difference in the power of the joint. It is by this tendon acting on this mechanism, that when the animal has inclined the angle between the canon and the tibia, or in other words, when the extremities are bent under him in the gallop or trot, that he is enabled to open it again. The bones of the hock, like those of the knee, are united together by strong ligamentous fibres; and it is to an inflammation of those uniting the calcaneum and cuboid bones, that the disease called *curb* is to be attributed; and to a similar inflammatory affection of the ligaments in the front of the hocks, that *spavins* of the first stage are owing; in the latter stages the periosteum and bones themselves become affected. The remainder of the bones below do not differ so essentially from the corresponding bones in the fore extremities as to need an individual description. It may, however, be remarked, that the hinder canon or shank bone is longer than the fore, and that the pastern is also the same, but is less oblique in its situation; by which wise provision the horse is enabled to elevate and sustain his body entirely on his hinder parts without danger, which would not have been the case if the obliquity of those parts had been considerable.

#### SECT. IV. *Of the Physiology or Functions of the Horse.*

5660. *The admirable mechanism displayed in the composition of the body of the horse, will appear by considering its various functions generally and particularly as a whole.*

##### SUBSECT. 1. *General Functions of the Bony Skeleton.*

5661. *The skeleton of the horse will be found to present nearly a quadrilateral figure, having an inclined cylinder resting on four supporting pillars. The spinal column, as the inclined cylinder, serves as a base for the soft parts, and is found not truly horizontal, but dipping downwards over the fore legs; by which the propelling force of the hinder extremities is relieved by the maximum of strength thus transferred. The increased weight of the hinder part of the cylinder, is admirably counterpoised by the head and neck, which are projected forwards; by these means leaving the line of direction near the centre of the whole. The length of the cylinder may be such as not to support its own weight; nature, therefore, has limited the length of the spines of animals: hence, *celeribus paribus*, a long-backed horse must be weaker than a short one; and thus, likewise, small horses can carry proportionably more than larger ones. The four pillars which support this cylinder, are not perpendicular partially; but they are so totally: for a perpendicular drawn from their common centre of gravity, will be found to fall nearly in their common base, by which means they are supported as firmly as though their individual axes had been in a line perpendicular to the horizon. Had they been perpendicularly opposed to each other, there could have been but little elasticity, and consequent ease in motion: every exertion would have proved a jar, and every increased effort would have produced laxation or fracture. To increase our admiration of this*

mechanism, we need only turn our attention to the contra-disposition of these angles in the fore and hinder supporting pillars. Had these angles presented themselves in the same direction, the body must have been precipitated forward or backward; but each offering a counteraction to the other, the body is firmly sustained within them.

5662. *The bony masses are operated on by muscles*, for this deviation from a perpendicular direction in the various bony portions of the limbs, must necessarily have powers to correct it, which is done by the muscles; and wherever the angles are found most extensive, the muscles will be found proportionally strong and large. This muscular exertion, to counterbalance the angular inclination, occasions fatigue; as the set of muscles immediately employed becoming weary, the animal is obliged to call another set into action, which change is necessarily more or less frequent as the animal is weaker or stronger.

5663. *The extent of the action of the bony portions of the extremities*, is the produce of the length and direction of the various parts entering their composition, and of the different angles they are capable of forming, as progression itself is effected by these angles closing, and suddenly extending themselves again. The force of the action arises from the direction of the component parts of the angles, in combination with the agency of the muscles. The repetition of the action is dependant on the muscles alone; but as the original action arose out of the length and direction of the parts, so it will be evident that in every subsequent repetition, it will be more or less extensive, as these are more or less perfect in their formation, even though the muscular exertions should be the same: thus some strong animals cannot move so fast as others with less strength, as the cart-horse and racer, or greyhound and mastiff.

5664. *The bony mechanism of the fore and hinder extremities presents some differences.* That of the fore limb may be said to exhibit altogether a different character. The fore-leg bones are much less angular, and appear framed purposely to receive the weight imposed on them by the impulse of the hinder limbs. This weight they are destined to sustain, until the elevation is forced on them by the tendency the general inclined mass has to meet the ground, or to find its common centre in the earth. The fore extremities, under this view of the matter, could not have been placed with equal wisdom in any other situation, nor have taken any other form. The hinder extremities having less weight on them, and at no time bearing an increase of pressure as the fore do, by the impetus communicated from behind, are much more angular; and their angles, by being thrown into a backward direction, afford the necessary impetus for the projection of the body forward. This important operation of impelling the mass being almost wholly dependent on the hind extremities, as that of sustaining it is principally confined to the fore extremities; so the former are also much stronger in point of muscular apparatus; by which their angles can be advantageously opened and closed with superior effect in progression.

5665. *The appendages to bone* are cartilage or gristle, periosteum, medulla or marrow, ligaments, and synovia or joint oil. *Cartilages* are of three kinds, *articular* (1850.) which cover the ends of the bones by a thin layer, enabling them to slide easily on one another; *nonarticular*, or such as are placed between bones immovably joined; *unattached*, as those of the ears and larynx; and *temporary*, as the ends of bones in very young animals before their earthy deposit is completed. The general nature of cartilage is smooth, white, solid, elastic, and hard. The *periosteum* is a general uniting membrane to bones and their appendages (1845.), on the skull, called *pericranium*; when it covers ligaments, *peridensium*; and *perichondrium* when it invests cartilage. Its uses appear to be to furnish vessels to the bones. It is little sensible, except under inflammation, when it becomes highly so. *Medulla*, or marrow, is a soft fatty substance deposited in the cavities of bones.

5666. *Ligaments* (1854.) are close, compact, fibrous substances, of immense strength in the horse, necessary to bones as a connecting medium; ligament is also a common membrane in every part of the body. The nature of ligament is considered as inelastic; there are, however, many exceptions, of which the cervical and metacarpal and metatarsals are instances. In some cases they are semicartilaginous. The *suspensory* ligaments attach and suspend parts, as that of the thigh bone to its socket, &c. *Capsular* ligaments surround the two opposed ends of jointed bones, and form a complete cavity.

5667. *The synovia* or joint oil, being secreted from the inner surface of the capsular ligaments, fills up this cavity, and affords a slippery medium, which enables the bones to slide readily over each other.

5668. *Muscle* is that part of the body of the horse which we term flesh, to distinguish it from skin, gristle, bone, ligament, &c.; and the phenomena it exhibits, are so universal, that we are warranted in considering that it exists in every animal. Muscles appear composed of bundles of reddish fibres, the ultimate division of which it is impossible to trace. When a number of these fibres are connected together into a determinate form, and circumscribed extent, it is called a muscle; and as the motions of an animal are very various, and as almost all motion is operated through the agency of the muscles; so the peculiar shape they take on is very varied. Muscular fibre is spread over the body, and it has been very properly remarked, that our ideas of it are probably too limited: thus it constitutes a principal part of all the viscera, and enters, it is probable, into the composition of many membranes. But what is more generally considered as a muscle, is a distinct body having its determinate parts. To the generality of muscles, particularly to those ending in bones, is added a portion of a very different nature, called *tendon*.

5669. *Tendons* are inextensible, inelastic, tough, fibrous substances, of a whitish colour: expanded into thin layers, they are called *aponeuroses*. The tendons are eminently useful to muscles, for the size of the termination is thereby diminished, without the strength being decreased. What would have become of the lightsome elegant limb, had their large muscular masses been continued downwards of the dimensions we witness them above in the shoulder and thigh, instead of the condensed substance of the tendons or back, and fore sinews? Muscles are highly vascular, as their color testifies; but the tendons are very little so, hence their powers of life are very different: one can regenerate itself with ease, the other with extreme difficulty. The muscles also possess a large share of nerves, and consequently of sensibility and irritability, to which properties the surprising phenomena they exhibit must be attri-

buted; while their extreme vascularity furnishes them with powers to keep the energies requisite for these agencies. They contract and shorten at pleasure, acquire a power of acting dependant on their situation, and can change the fixed for the movable point, and *vice versa*.

5670. *Muscles are voluntary and involuntary.* The former are immediately under the influence of the will, as those of the legs, eyes, mouth, &c. Involuntary muscles are such as are not under the guidance of the will, and whose functions go on without control, as the heart, the respiratory and digestive muscular organs. Voluntary muscles have usually antagonists, whereby the perpetual tendency to contraction is counterbalanced: they are also usually covered by a cellular or membranous covering, called *fascia*, and their tendons by another, but stronger investure, called *theca* or *sheath*. At the tendinous extremity there is usually a *capsule* containing a quantity of lubricating mucus, the diseased increase of which forms what is termed windgall.

### SUBJECT. 2. *The Blood Vessels of the Horse.*

5671. *The arteries are long membranous canals,* composed of three strata, which are called *tunicæ* or *coats*, as, an external elastic, a middle muscular, and an internal cuticular. Each of these coats is the cause of some important phenomena, as well in disease as in health. The *elastic* power enables them to admit a larger quantity of blood at one time than another, and thus they are *turgid* under inflammation: by this also they can adapt themselves to a smaller quantity than usual; otherwise a small hemorrhage would prove fatal. The muscular tunic appears to exist in much greater proportion in the horse than in man, and this accounts for his greater tendency to inflammation, and also why inflammatory affections run to their terminations so much sooner in the horse than in man. The arteries gradually decrease in their diameter as they proceed from the heart. Our knowledge of the terminations of these vessels is very confined; we know they terminate by anastomosis, or by one branch uniting with another. They terminate in veins, and they terminate on secreting surfaces, in which case their contents become changed, and the secretion appears under a totally different form. Another common termination of the arteries is by exhalant openings, by which sweat is produced. The use of the arteries is evidently to convey blood from the heart to different parts of the body, and according to the part the artery proceeds from, or proceeds to, so does it receive an appropriate name.

5672. *The aorta* is the principal member of this system. Originating from the left ventricle of the heart it soon divides into two branches, one of which, the *anterior, or aorta ascendens* (fig. 618 p), proceeds forward to be divided into two principal divisions—the *carotids* (q), by which the head is furnished, and the *axillaries*, by which the fore limbs receive their blood, under the names of humeral, radial, and metacarpal arteries. The *posterior, or aorta descendens* (o), which is distributed to the trunk and hinder extremities, forms the other branch.

5673. *The pulmonary artery* is a trunk of five or six inches in length; arising out of the anterior ventricle of the heart, and is continued by the side of the aorta. It soon divides and enters the lungs, through which it ramifies.

5674. *The veins are vessels, which return the blood* of the body which has been distributed to it. They have less solidity, and possess two tunics or coats only. They usually accompany the arteries in their course, but are more numerous, being wisely divided into a superficial and a deep seated set, to avoid the dangerous effects of interruption. To prevent the return of the blood they are furnished with valves also.

5675. *The original venal trunks of the horse* are ten in number; as the anterior cava, the posterior cava, and eight pulmonary, to which may be added the *vena portæ*.

5676. *The vena cava* passes out of the heart by two trunks from separate parts of the right auricle. The *anterior, or cava ascendens* (fig. 618 n), opposite to the first rib, divides into four principal trunks; two axillaries, and two jugulars, (fig. 618 r). The axillaries furnish the fore limbs under the names of the humeral, the ulnar, and the metacarpals. The *jugulars* (r) run up one on each side of the trachea to return the blood of the head. The *posterior, or cava descendens* (o), returns the blood from the body and hinder extremities.

5677. *The vena portæ* is formed from the veins returning the blood from the viscera, which, uniting to enter a sac of that viscus, are ramified through all parts of the liver, to have some remarkable operation performed in their contained blood. Collected again after this operation, the blood is returned by the *vena hepatica*, and carried into the posterior cava.

5678. *The blood is a homogenous fluid,* contained in the heart, arteries, and veins, and constantly circulating through the whole body. It appears formed with the body; is red in the arteries, and purple in the veins. (5723.) The component parts of the blood are the cruor or coagulum; the coagulable lymph, fibrin, or gluten; and the serum. The coagulum is composed of red globules, whose intensity of color is less in the horse than in man. A red color is not necessary to the essential properties of blood, seeing the blood of some animals is white; and even some parts of the horse's body are furnished with colorless blood, as the transparent part of the eye, &c. The coagulable lymph or fibrin, (1904.), appears the most essential part of the blood, and from which all the parts are formed. The serum seems to dilute the whole. The quantity contained in the body is uncertain: young animals possess more than older, and hence bear bodily injuries better. It is less in quantity in fat than in lean animals; and in domesticated than in those which run wild. An animal will lose 1.15th before he dies. A horse lost 44 pounds without apparent injury. Probably the quantity contained in the body may vary according to circumstances: between 1.8th, and 1.10th of the whole mass, is a fair medium.

5679. *The pulse.* From the contraction of the heart and consequent dilatation of the arteries to receive the blood, and pass it onward to all parts of the body, which is called the *diastole*; so a dilatation of the heart and contraction of the arteries necessarily occurs, which is called the *systole*: and these two causes operating alternately produce the phenomena of circulation. The momentary increase in capacity in the diameter of the artery is called the *pulse*. As there is seldom disease present, without some alteration in the circulation also, so the pulse is attended to as an indication of health or disease. The circulation being carried on over the whole body, the pulse may be felt universally; but some situations are more favorable than others; as the heart itself, the pasterns, at the root of the ear, &c.: but the most convenient of all, is at the branch of the posterior jaw, where the maxillary artery may be readily detected. (fig. 618 t). The natural pulse in the horse is about 45 beats in a minute; in the ox the same; in man 75; in the dog 90. When the pulse is much accelerated, the circulation is accelerated also. If to its quickness, fullness of vessels and hardness are apparent, the circulation is *morbidly* hurried, and inflammation general or partial is present. (5678.)

### SUBJECT. 3. *The Absorbents of the Horse.*

5680. *The absorbent system* is a very extraordinary and a very important one, for if the blood builds up and repairs parts, the absorbents pull down, remove, and take them away again. They are composed of the *lymphatics* and *lacteals*. Both kinds, although thin and transparent, are strong, and appear to have a contractile power: where very minute they are called *capillaries*. The lacteal absorbents are situated in the mesentery and intestines, from whence they draw the chyle or nutritious fluid by which the blood is nourished and augmented, by being carried forward from the mesentery into a tube called the

*thoracic duct*, which, passing up by the side of the aorta, pours its contents into the heart through the medium of the jugular vein. The *lymphatic absorbents* differ from the latter only, in being situated over the whole body, and being the recipients of the various matters of the body; whereas the lacteals appear to absorb the chyle only. From numerous facts, we know that the various organs are continually suffering a destruction and a removal of parts, and that what the absorbents take away, the arteries renew; and to this constant change, most of the alterations of the body are to be attributed as regards the structure of parts. We use our power over these vessels in the horse medicinally. We stimulate the absorbents to take up diseased solutions of fluids from various parts of the body, as in watery swellings in the legs by mercury, and by friction, or by pressure in the way of bandage. When deposits are made of hard matter, on ligament or bone, we stimulate them by blistering or by firing. It is by stimulating the absorbents that splints and spavins are removed. Exercise is a very powerful stimulus to absorbents; thus it is that swelled legs are removed by half an hour's exercise. In the horse, the lymphatics are more liable to disease than the lacteals, but in man the reverse. Farcy diseases the lymphatics irreparably.

#### SUBJECT. 4. *Nerves and Glands of the Horse.*

5681. *The nervous system of the horse* is composed of white medullary cords, springing from the brain and spinal marrow, whence they are generally distinguished into the cerebral and spinal nerves: the internal structure of these bodies is fibrous, and their ramifications extend to every part of the body; it is supposed that the brain is the seat of sensation and volition, and that the nerves are only the messengers of it. The sensibility of a part is usually proportioned to the number and size of its nerves; nervous influence occasions motion. From some cause, unknown to us, some motions are voluntary, and some involuntary; but both are brought about by nervous agency. As the nerves are the media of sensation; so a division of their cords has lately been attempted, with success, to relieve certain painful affections; the most prominent instance is, in the division of the pastern nerves for the relief of the painful affection of founder. Tetanus, or locked jaw, which seems a morbid irritation on the nerves, has been recommended to be treated in the same way.

5682. *The cerebri-nerve*, arising in pairs immediately from the brain, are the *olfactory, optic, motorius oculi, pathetici, trigemini, abducens, auditory, lingual, par vagum*, and the pair called the *intercostal* or *great sympathetic*, from its extensive connection.

5683. *The spinal nerves* are those which arise immediately from the spinal marrow, as the *cervicals, humerals, ulnar, metacarpal, and pastern* nerves; the *dorsal, the lumbar, crural, sciatic, popliteal, sacral*, and the nerves; to the posterior extremities, which correspond with those of the anterior.

5684. *The glands* are numerous, and placed in every part of the body; they may be characterized as secretory bodies, composed of all the different vessels inclosed in a membrane; their office appears to be to secrete or form some fluid, as the liver secretes bile, and the kidney urine. They are classed into folliculose, globate, glomerate, and conglomerate; they also receive specific names according to their situations, or according to the fluid they secrete, as lachrymal, salivary, &c.

#### SUBJECT. 5. *Integuments of the Horse's Body.*

5685. *The common integuments* may be considered as the hair, the cuticle, the epidermis, or insensible or outer skin, the rete mucosum, which is immediately under this, the cutis, sensible or true skin, the cellular membranes, which contain fat and other fluids, and the *panniculus carnosus* or fleshy pannicle; to these may be added, the *unguis*, nails or hoofs, which we shall describe separately.

5686. *Hair* is the clothing of brutes, and hence is very important to them, and as it enters largely into the arts, it is also important to us. (1814.) It appears to be a production of the true skin, arising from a bulbous end, which penetrates the rete and cuticle in the form of an elongated cone. In some parts hairs appear, singly, as about the muzzle; in others in masses, as on the mane, tail, and over the body generally, as an inclined congregated mass; hair varies in color, and therefore appears by nature intended both for ornament and use.

5687. *The cuticle is situated immediately under the hair* (1807.), and appears a hard insensible covering, purposely placed to guard or defend the sensible skin underneath. The cuticle lines many of the large openings of the body, as the mouth, from whence it is continued into the stomach, lining one half of it. It is perforated by innumerable small vessels that give out and take in various matters; through these blisters act on the true skin, inflame it, and force it to secrete a quantity of fluid, which thus pushes the cuticle from the cutis. It exists before birth, and is speedily renewed after birth, when accidentally destroyed, and, like the true skin, thickens by pressure; it is constantly undergoing changes; it exfoliates in the form of powder, or little scales, over every part of the body, and is that substance called dandruff, which grooms are so careful to remove with the currycomb. The *rete mucosum* is a mucilaginous substance placed like a net between layers of cuticle and cutis; and although very universal in animated nature, its use is unknown.

5688. *The cutis, corium, or true skin.* (1810.) This very general investiture of the body is situated immediately under the two former; it is very vascular, and is furnished with innumerable small villous processes of exquisite sensibility, and which, without doubt, were intended to constitute it as the real organ of touch. It is much thickened by pressure; asses, from the beatings they are subjected to, have it of immense thickness on the rump. It naturally also exists in various degrees of density according to the wants of the animal. Like the cuticle it is perforated by numerous openings which correspond with those of the latter membrane. Its composition appears principally gelatine, and hence it is employed in the manufacture of glue; its gelatine uniting with the matter called tannin, becomes insoluble in water, and then forms leather; and the value of the horse's hide in this particular is sufficiently known.

5689. *Adipose membrane and fat.* These form very considerable parts of the body of most animals. The adipose membrane is not so universal as the skin; some parts are completely without it, as the eyelids, ears, sheath, and some parts of the extremities. It is cellular, but the cells fortunately do not communicate or the fat would gravitate. The fat is the unctuous juice poured or rather secreted into these cells. It appears in greater quantities, and in different degrees of consistence in some parts than in others: in the belly of some it is lard, and suet in others; within the bones it is oleaginous in all. Different quadrupeds have their fat of different degrees of consistence, from the firm suet of the ox, and the tallow of the sheep, to the soft lard of the hog, and the intermediate state of the horse; it guards the parts, it preserves warmth, but above all, it is a depot against occasional want: thus a fat animal can sustain itself without food much longer than a lean one. The torpid bear comes from his hibernation emaciated, because his constitution has been subsisting on his fat.

5690. *Cellular membrane.* (1812.) This complete investiture of the body enters every part, and is formed of communicating cells, as we see by the practice of butchers who blow up their meat; and also by the emphysematous effects of a fractured rib, and the gaseous distention in some putrid diseases; it exists in different quantities, and under various modifications of density throughout the body, and is a very universal medium of connection in the form of ligament.

5691. *Panniculus carnosus.* (1819.) The fleshy pannicle was kindly given to quadrupeds in lieu of hands, to enable them to corrugate or pucker the skin, and thus to shake off dust and insects. It is a thin muscular expansion peculiar to brutes, but not to all; the swine family being denied it. By its attachments it can operate variously, as we see by the uses the horse makes of it; it is very vascular, and sensible also from the numerous nerves which enter it.

SUBJECT. 6. *The Head generally.*

5692. *The parts of the head* are external and internal; some of these have been touched on, as the integuments, &c.: such as have not will follow in the order of their magnitude or situation.

5693. *The brain of the horse* (fig. 616 a, b, c), is contained within the hollow of the skull, and is surrounded by two coverings, the dura and pia mater, between which lies a third membrane called the tunica arachnoidea. The duplicatures of these membranes are called septa and falx. The brain is divided into three portions, the cerebrum, cerebellum, and medulla oblongata. The cerebrum, or greater brain (a), is divided into two hemispheres and two lobes; it has an outer or cortical substance, and an inner, the substantia alba, or medullary matter. The cerebellum, or lesser brain (b), is contained within the occipital bone, and is in the horse placed superiorly and posteriorly to the cerebrum. It is less than the cerebrum, and is divided into four lobes, and like the former is composed of two substances, a cortical and a medullary. The medulla oblongata (c) is a medullary continuation of the cerebrum and cerebellum, and is continued upwards and backwards to the edge of the foramen magnum of the os occipitis, to be continued under the name of spinal marrow. The medulla spinalis, or spinal marrow (k), is a direct continuation of the medulla oblongata, and like that is composed of a cortical and medullary part. It has lately been discovered to be hollow in the horse, ox, sheep, hog, and dog. It leaves the skull by the great foramen of the occipital bone, and is continued backwards in a bony canal formed by the vertebrae, giving off in its passage the spinal nerves in pairs. The brain presents four cavities called ventricles, it has also many prominences, and peculiarities, which our limits will not admit of noticing, but which is less necessary, as in no part of brute anatomy is the analogy so close to the human as in the brain of the horse. With the exception of the situation, to describe the one is to portray the other.

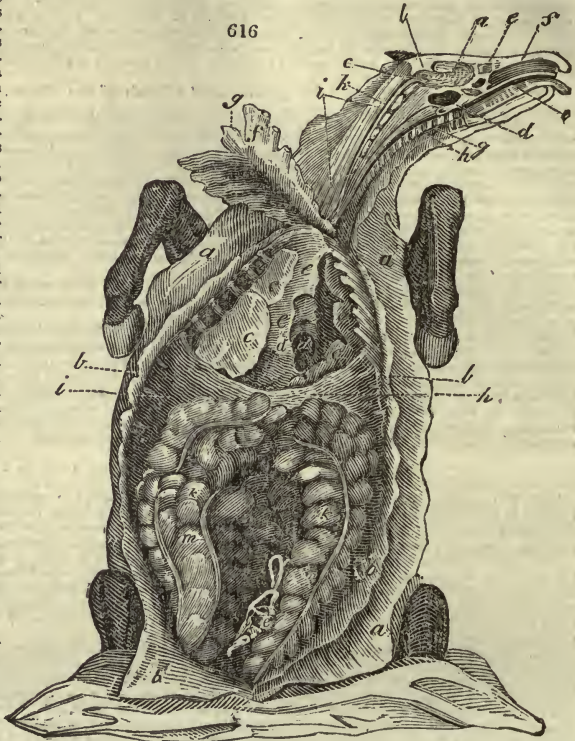
SUBJECT. 7. *The Ear.*

5694. *The number and situation of the ears* of the horse are sufficiently known. The internal parts do not differ from those of the human, but the outer are adapted to his situation and habits. These exterior parts are composed of the skin, the outer hair, the cartilages, and the muscles by which they are moved. The skin within the ears is furnished with sebaceous glands, which secrete a bitter matter, noxious to insects; and further to guard against these, it is filled with hair; which the false taste of grooms induces them to remove, and thus to expose the animal to dust, hail, rain, and insects.

5695. *The form of the ear is dependent on the concha cartilage*, which is found pointed and small in the Arabian, but large and broad in the heavy breeds. The cavity within the concha is thrown into folds throughout, which increases its surface, and reflects the sonorous waves. This outer ear is attached to the internal, by connecting cartilaginous portions and appropriate ligaments. The parts of the internal ear are, the meatus auditorius internus, or passage; the membrana tympani, or separating membrane between the external and internal parts; the tympanum, drum, or barrel of the ear; and the labyrinth. The eustachian tube is an opening at the upper and anterior edge of the hollow of the tympanum, forming a duct which is in part bony, and in part cartilaginous; extending from the tympanum to a large and peculiar cavity at the posterior part of the nasal fossa.

5696. *The sense of hearing* is formed through the medium of the expansion of the soft portion of the auditory nerve over the internal ear; sounds, therefore, entering the cavity of the concha, are reflected alternately from its sides into the tympanum, whose oscillations are imparted to the brain.

SUBJECT. 8. *The Eye and its Appendages.*

5697. *The appendages to the eye* are first, a funnel-shaped cavity formed by the concurrence of the bones of the skull, called the orbit, not placed directly in front as in man, but inclining laterally, to enable the animal to embrace a larger field of view. The eyelids are an upper and under, of which the upper is the most considerable, and



enjoys the greatest motion. United, they form an admirable curtain to defend the eye from dust, insects, and the light during sleep; and are moved by two appropriate muscles. Attached to the edge of each is a cartilaginous rim, called the tarsus. The *cilia*, or eyelashes, are not, as in the human, above and below; the upper lid only is furnished with hairs, and which are not placed in one, but in several smaller rows. The horse has no supercilia or eyebrows, unless we reckon as such the few long hairs over the orbits. The *lachrymal gland* is a body lodged within the upper part of the orbit, and is furnished with five or six excretory ducts, which secrete the lachrymæ or tears to lubricate the surface of the globe. The superfluous tears are carried off by two openings at the inner angle, called *puncta lachrymalia*, by which means the tears are at once carried into the nose, and not as in man first into a lachrymal sac. The *caruncula lachrymalia* is a small black substance in view at the inner canthus, whose office appears to be to direct the tears aright in this course. The *haw*, or *nictating membrane*, is an important part, seen when the eye is drawn inwards, but which is at all other times hidden within the fatty matter surrounding the globe of the eye. Though called a membrane it is cartilaginous, and when the eye is forcibly withdrawn into the socket, it is pressed out from the inner angle, and passes completely over the surface of the globe, to which its shape is adapted. A moderate pressure only, shows about half of it; and it is thus seen in tetanus or stag-evil, by the action of the retractor muscle; and under inflammation of the eye it also becomes visible, which has led ignorant farriers to cut it off, under a suspicion that it formed one cause of the disease. The use of this nictating membrane cannot be for a moment dubious. It is denied to man and to monkeys, because they, having hands, can with their fingers remove dust and dirt from the eyes; but to the horse and most other quadrupeds, it is essentially necessary for these purposes.

5698. A diagram of the eye (fig. 617.) displays the transparent cornea in front of the eye (a), the crystalline lens (b), its posterior convexity (c), its anterior convexity (d), the iris, or curtain (e, f), the anterior chamber occupied by the aqueous humor of the pupil (g), the posterior chamber filled with the vitreous humor (h h), the retina (i), the choroid coat (k), the sclerotic coat (l), and optic nerve (m), rays of light showing the different degrees of refraction they suffer in passing through the humors of the eye (n n).

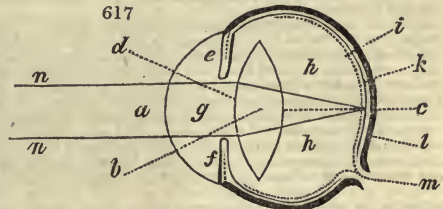

5699. The globe of the eye is composed of coats, chambers, and humors, and is operated on in its movements by muscles. It may be considered as forming a large cup posteriorly, with a smaller cup applied to its margin anteriorly; or as though the segment of a large sphere were adapted to that of a smaller one. The substance which gives figure and consistence to the larger segment is the *sclerotic coat* (l), which is very firm and fibrous. The anterior cup or segment is supplied by the cornea, which is transparent, and formed of thin concentric plates of very different degrees of convexity in different animals, and often of similar animals; to a defect in which is ascribed the indistinct vision or starting of some horses. The *cornea* (a) is vascular and sensible, and in an inflamed state it admits the red blood, as we see by the universal redness over the whole; at other times it admits only the colorless parts of that fluid. Immediately within the sclerotic coat is a thin vascular membrane, called the *choroides* (k), which is spread over it nearly as far as the cornea, where it turns in and expands into the ciliary processes. It also, by a peculiar fold, forms a ligament, after which it produces another projection into the cavity of the eye, termed the *uvea*. It is here continuous, and presents a veil perforated in the centre.

5700. The pupil of the eye (g) is the perforation which is seen annular in the human, oblong in the horse, ox, and sheep, and perpendicular in the cat. The anterior surface of the uvea is covered with a membrane, termed iris, on which the color of the eye depends; in man it is grey, brown, black, or blue; in the horse it is usually brown, but now and then white, when the animal is said to be wall-eyed. At the central margin of the iris are seen, in a strong light, some little globular bodies or bags, covered with a black pigment. They are usually attached to the upper margin only, but when any excess on the lower they are small; they have been mistaken for disease. The *iris* (e, f) is capable of accommodating itself to circumstances; that is, it can enlarge the diameter of the central aperture or pupil (g), so as to admit or shut out the rays of light. Over the central surface of the choroid expansion is spread a dark mucous substance, called *nigrum pigmentum*. In animals, whose vision is distinct at night, this pigment is found of a lighter color; in man it is very dark, and his crepuscular vision is, therefore, indistinct. In the grazing tribes it is of a greenish cast, lost in azure blue; in the predaceous tribes it is still lighter. Under this pigment is the mucous expansion, peculiar to quadrupeds, called *tapetum*. The *optic nerve* (m) penetrates the sclerotic coat, and becomes expanded on its inner surface, in a membranous lamina of exquisite fineness, called *retina*. On this it is supposed objects are painted, and thus taken cognizance of by the brain.

5701. The humors of the eye are the vitreous, the crystalline, and the aqueous. The vitreous humor (h h) is of a jelly-like consistence, and occupies all the globe, except those parts taken up by the other humors. The *crystalline humor* forms a lenticular body of moderate consistence, and is, therefore, more properly called a *lens* (b). It is doubly convex (c, d), its posterior side resting in a concavity of the vitreous humor. It is not of equal consistence throughout, being much firmer in the middle. Different animals have the lens of different figures, to suit the purposes of their existence: in fishes it is nearly spherical, but in quadrupeds, lenticular. It is a diseased opacity of this body that forms cataract. The *aqueous humor* is a limpid fluid which fills up the spaces not occupied by those already described.

5702. The muscles of the eye. The motions of the eye ball are operated by seven muscles; four recti or straight, which elevate, depress, and draw to and from; two oblique, which rotate the eye, and a retractor or choanoid, which is peculiar to quadrupeds, to draw the eye within the socket, and thus preserve it from danger, draws the globe on wards.

5703. The phenomena of vision. If the diagram be examined, it will be evident that the eye of the horse presents an optical instrument of exquisite workmanship and mechanism, admirably fitted to collect the luminous rays from the various objects around, and to transmit them with truth to the brain. If the

luminous rays reflected from objects passed through the eye in a rectilinear course, as they do through the atmosphere, no cognizance at all useful to the animal could be taken of them by the eye; all would be glare and indistinctness: but being refracted or bent by the media, through which they pass, the rays finally meet at a point called their focus or focal point. Neither would one simple line of refraction have been sufficient to have answered all the purposes of perfect vision, under its various modifications. It is necessary that the refraction should be increased in its passage by increased degrees of density in the media of its transit (*n n*). In the passage of the rays through the cornea and aqueous humor, they must encounter their first refraction; and it is evident, that the more convex the anterior portion of the eye may be, the more will this refraction be increased. We need not, therefore, be surprised that a goggler, or horse with this form of eye, should start. The next and largest degree of bending which the rays receive occurs in their passage through the crystalline lens, which from its lenticular form must necessarily be considerable; in their progress through the vitreous humor a farther refraction is effected, till meeting in a point on the retina, a perfect representation of the object or objects viewed is obtained; the rays forming in their passage numerous cones, the basis of which will be the object viewed, and the apex of each a radiant point. Amidst the number of objects around, it appears that the eye has a capability of collecting rays from such only as are immediately necessary for the purposes of the animal it belongs to; hence, although the general field of view may fall under an angle of vision, yet such rays only as are immediately capable of this convergency produce effect, all others are lost in the black pigment of the eye, apparently placed there purposely to absorb the superfluous rays. As the eye must necessarily have a vast variety of objects painted on it, whose distances are widely different; there must be some optical adjustment of the powers of the part to enable it to effect a distinct vision of all objects near or remote. But whether this takes place by means of the angle formed on the two opposite axes, or as has been more lately taught, by a muscular power in the lens itself, is not yet satisfactorily ascertained; certain it is that after the loss of one eye, time is required both in the human and brute subject for the remaining eye to learn to adjust itself to judge of relative distances; which fact is certainly in favor of the opinion that an angle formed between the eyes regulates the judgment of distances. In this way we can account for the well known fact, that hunters, which have before the loss of an eye been excellent and sure leapers, have afterwards lost the power of measuring their leaps. Were it not for some adjustment of the optical organ itself, the rays reflected from objects very near the eye would fall behind it, and those from distant ones would, from being almost parallel, meet together before the retina. The mechanical adjustment of the focus is also assisted in some measure by the iris, which contracts almost to a point when we look at a very minute object; and by this means only permits such rays to pass through as penetrate the centre of the lens, by which such rays will be very much refracted; but when the eye regards distant objects, the iris becomes dilated, and the rays are then viewed through the edges of the lens, and their inclination is thereby lessened.

5704. *The criteria of soundness in the eyes are gained by a careful examination of them; and which experience has shown to be best made by placing the horse within a stable, with his head nearly approaching the stable door, which should be fully open. Small eyes are found more prone to inflammation than large, and large goggling eyes are more liable to accompany a starting horse than lesser ones: and when the convexity is extreme, not only is the starting in proportion; but such eyes are more liable than others to become affected with the disease popularly termed glass eyes, but correctly gutta serena. It is not however to be understood that all starters have defective eyes; many are so from natural timidity, and still more from harsh usage. The eyes should be examined together, not only to observe whether each presents an equal degree of clearness in the transparent part and within the pupil; but also that an equal degree of contraction exists between each of the pupils. This is of much consequence: if any inequality in size or form be observable between the pupils, the least of them has been in some way affected, and will probably become so again. It is even more suspicious when a turbid milkiness appears on any part of the transparent portion; and equally so, when the inferior part looks other than clear; or in a very strong light, with a lively bluish tinge. When it is at all turbid, viewed under various aspects, regard it attentively, and there may probably be found an inward speck of perfect white; which is the nucleus or central point of an incipient cataract.*

5705. *A glassy greenish cast in the eye should occasion suspicion, and the hand should be placed over such eye so as to exclude the light; remove the hand suddenly and watch the motions of the iris or curtain of the pupil. If it do not contract, carry the examination still further, and it will probably be found such eyes are totally blind. A blind horse usually carries his ears about, as though in alarm, on his leaving the stable; he also lifts his feet on such occasions, particularly in strange quarters, higher than a sound horse.*

#### SUBJECT. 9. *The Nose and Sense of Smelling;*

5706. *The organ of smell is, in most quadrupeds, the next in importance to that of vision, and in many points of view it is even more so. With the herbivorous tribe, it forms their principal means of judging between the noxious and the innoxious. It is not therefore to be wondered, that it should in these tribes form so large a portion of the head; nor that it should be so exquisitely gifted with sensibility, or so admirably formed to answer its important purposes. The external parts of the nasal organ are the two nostrils, and as much of their convolutions and linings as come into immediate view. Internally these two cavities are carried upwards into the pharynx, but completely divided by a cartilaginous septum, (fig. 616 f). In this course they communicate with numerous openings and cavities, formed within the bones of the skull, (5631.) the whole of which are lined by one continuous membrane of exquisite vascularity and sensibility; being largely furnished with blood vessels, which gives them such a ready tendency to inflame and become red, as we witness under only a slight degree of exertion, and as we see more evidently when violent colds or inflammations on the chest are present. Its sensibility is derived from the olfactory nerves, which are spread over all its surface. It is this membrane which is the peculiar seat of glands, becoming first inflamed, and next ulcerated throughout its extent; and as the membrane itself appears to be continued to the pharynx and larynx, so we need not wonder why the glands proceed to disease the lungs; nor why a common cold, which is at first a simple inflammation of this membrane, so readily degenerates into inflammation of the lungs. The common integuments or coverings of other parts are extended over the nose, but it is little furnished with fat. Of hairs it has a fine thin covering to the edges of the nostrils, and a longer set, which are carefully removed in trimming. By a fold of the skin, within which is a cartilage, the false nostril, as it is termed, is formed, whose use appears to be to keep open the canal for the transmission of air, and yet to offer an interruption to extraneous matter. When the nostrils are a little separated, a small canal may be seen, which is the nasal duct for the transmission of the superfluous moisture from the eyes. The horse breathes or respire wholly through his nostrils in all ordinary cases.*

5707. *The sense of smelling. The volatile particles from all odorous bodies are continually passing off from them, and consequently some must reach the olfactory organs, whose capability of taking cognizance of their qualities appears derived as before pointed out, by the expansion of nervous fibrillæ from the olfactory nerves which transmit impressions to the brain.*

#### SUBJECT. 10. *The Cavity of the Mouth.*

5708. *The external parts of the mouth are the lips, cheeks, and beard. The lips are made up of fleshy masses so disposed as to give them motion every way; they are covered over with a very fine expansion of skin almost devoid of hair, their exquisite sensibility forms them into an organ of touch; and in this*

point of view they may be considered as supplying the part of the points of the fingers in man. The cheeks are equally muscular and movable, but are more furnished with hair; and the beard, in addition to its thin hairy expansion, has a set of long hairs.

5709. *The internal parts of the mouth* are the teeth, already described (5591.), the gums,\* the alveolar edges, the palate, the tongue, and the parts of the great posterior cavity. The gums are a spongy substance which embraces and holds fast the teeth in their *alveolar sockets*. The membrane which covers the gums at the lower part of the channel forms a kind of fold to connect and confine the tongue on each side. These folds are called the *barbs*, and are apt to be mistaken and cut off as excrescences. The *bars* are the spaces in the jaw left between the grinders and nipper teeth; and which man, ever ready to take advantage for his own purposes, has applied to ensure obedience by placing on its sensitive surface the pressure of the bridle bit. The *palate* forms a bony arch, covered by membranous folds, which are apt, when the stomach is affected, to become swollen, in which case the horse is said to have the lampas or lampers. (5756.) By means of these rugose folds, the food is retained within the mouth. The *curtain of the palate* or *velum palati*, which is situated at the extreme end of the palatine arch, is stretched directly across the hinder mouth, and is not intercepted as in man by the pendulous body, termed uvula. This palate curtain is intended to shut out the communication between the mouth and the great cavity of the fauces, which it does at all times, except when the horse is swallowing, at which period the curtain is forced back and the food passes. From this cause likewise the horse is prevented breathing but by his nostrils; and when any air does pass by the mouth, as in coughing, crib-biting, &c., it is only effected by a forcible displacement of the curtain.

5710. *The tongue is a long fleshy mass* (fig. 616 e), which adapts itself below to the form of the channel, and above to the arch of the palate: its external surface is rough by means of papillæ, which are inclined backwards, and thus resist the loss of the food received within the mouth. In some animals, as the ox, bear, &c., they are very large, and in the cat pointed. The tongue is a very principal organ in mastication, carrying, by its great mobility, the food into every direction until fully acted upon, and finally passing it into the pharynx.

5711. *Sense of tasting.* It is not observed that this sense is so diversified in brutes as in man; but it is instinctively so correct, that it seldom errs in the herbivorous tribes; and when it does, there is reason to suspect some present defect in the organ, arising from morbid sympathy, which (as in the instance of salt-water, of which at some times horses will drink immoderately,) prompts them to take in matters they are accustomed to refuse. Taste was given to brutes to regulate their other senses, and thus there are few plants or substances, whose application to the tongue, under ordinary circumstances, produces an agreeable effect, but such as are proper for food. Nature, therefore, stimulates her creatures to search for edibles by a double motive, the calls of hunger and the pleasures of taste; and these are usually in unison, for the nausea of repletion destroys the appetite of taste.

5712. *The pharynx.* Both the cavities of the mouth and nose terminate in the great cavity of the fauces called by this name, to which also is appended another lesser opening called the larynx, immediately appropriate to the entrance of the trachea or windpipe. Within this great chamber, at the after-part of the mouth, shut from it by a membrane only, is the eustachian cavity, into which the eustachian tube opens, and which great membranous hollow is unknown to man and most quadrupeds (fig. 616 d). Its use is not understood, but it is probably connected with the voice.

5713. *The larynx* is situated at the posterior part of the former cavity, and appears as a cartilaginous box between the os hyoides, to which it is attached for support. This cartilaginous box, or entrance to the windpipe, is formed of several pieces, and is furnished with a kind of movable door, which, in ordinary cases, exactly fills up the cavity left by the arch of the palate curtain, thereby shutting the cavity of the mouth, and forcing the animal to breathe through his nasal openings. In extraordinary cases, as when the animal swallows food, this cartilage is forced down, and then it becomes a door to the glottis or funnel part of the trachea, and thus prevents the entrance of extraneous matter into the lungs. All these parts are operated on by numerous muscles.

5714. *The voice.* The larynx forms the larger part of a funnel-shaped tube, intended to introduce air within the lungs; but it has also another important office in being the organ of the voice. The cartilages of the larynx are very movable on one another, and are furnished with muscular cords, which tighten or relax them; besides which, they are also furnished with peculiar and appropriate sacs or cavities, independent of the tracheal opening; and which are of different magnitudes and directions in different animals. The cartilages of the larynx being acted on by the *cordæ vocales*, produce different degrees of density, and consequently different degrees of expansion in the laryngeal sacs; by which, either in expiration or inspiration, are produced different degrees of vibration, and consequent intonation. *Neighing* appears produced wholly by expirations through the nose, as are most of the tones of the horse's voice. This is proved by slitting the nasal cartilage, which wholly stops it. *Knuckering*, as it is termed, is only a lesser neigh, with shorter, deeper, and less forcible tones. The former sound is used as a call, the latter as either call or recognition. It is likewise, when used mildly, significant of joy and affection, and is then beautifully sonorous. The horse has an acute sound produced by inspiration, usually descriptive of lust: in most other cases his intonations are accompanied by expirations; nor does it appear that the tongue or teeth of the horse are much concerned in the modulations of his voice.

5715. *The parotid glands*, or, in the language of farriers, the *vines*, are two considerable bodies on each side of the head, extended from the base of the ear around the angle of the jaw. Each parotid is a conglomerate gland, furnished with numerous little ducts, which unite into one, and enter the mouth about the second molar tooth. These glands furnish saliva for the use of the mouth, and it is an induration and gathering, either in them or the maxillary glands, which forms the strangles of young horses. Assistant to these in the furnishing of saliva are the *maxillary* glands, situated within the branches of the lower jaw, and the *sublingual* also.

#### SUBJECT. 11. *The Neck.*

5716. *The external parts of the neck* are the common coverings which have been described; the cervical ligament, the muscles, and the jugular or neck veins, &c. The *cervical ligament* (fig. 616 i), is a very strong substance, in some parts semimuscular, and in all extremely elastic, stretched from the occipital bone along the back of all the cervical vertebræ except the first. Continued on the spinous processes of the dorsal vertebræ, it fills up the dip or depression of the spinal column of the neck, so completely as to form the neck either into a plane, or an elegantly convex line upwards. By its extreme tenacity, the ponderous mass of the head is preserved in its situation, without the necessity of an immense mass of muscle, which would, without this contrivance, have been necessary. It is to an injury received at the upper and anterior part of this ligament, that the pole evil is owing. The muscles of the neck are too numerous to allow of particularization; it is sufficient to say, they most of them run longitudinally. The jugular veins run one on each side of the neck superficially, on the side of the trachea and windpipe, and form the vessel usually bled from (fig. 618 r). A few inches before they reach the angle of the jaw, each divides to furnish the head.

5717. *The internal parts of the neck* are the vertebræ, within which passes the spinal marrow. The *carotid arteries* pass up under the jugular veins, near the œsophagus (fig. 618 s). The *trachea* or windpipe (fig. 618 g), is a large canal for the transmission of air, formed by alternate rings of membrane and segments of cartilage, rendering it at once flexible, yet cylindrically hollow. The *œsophagus* (figs. 616 h & 618 s), is the continuation of the funnel-like cavity of the pharynx. It is externally muscular, and internally membranous and cuticular, by which formation it is elastic, to allow of distension in

the act of swallowing. The œsophagus penetrates the chest between the mediastinum, and passing along the spine (fig. 618 *l*), through an opening in the diaphragm, terminates in the stomach.

#### SUBJECT. 12. *The Thorax or Chest.*

5718. *The chest* of the horse is bounded anteriorly by the matters filling up the space between the two first ribs, posteriorly by the diaphragm, laterally by the ribs, above by the vertebræ, and below by the sternum or breast bone. In dissecting the horse, after the interior membranes, muscles, &c. are thrown back (fig. 616 *bbb b*), there appear the lobes of the lungs (*c c c*); & the heart (*d*); mediastinum or membranous division of the chest (*ee*); the sternum or breast-bone (*f*); the ensiform cartilage (*g*); tendinous centre of the diaphragm (*h, i*).

5719. *When the chest is opened* a smooth polished membrane is seen, which covers the surface, and then is reflected over its contents; this is called the pleura: and by a junction of the two pleuræ, a division of the chest into two nearly equal portions is effected, which membranous division is called the mediastinum. By this division of the chest into two parts, very important benefits arise; as when one cavity is opened the lungs immediately collapse, but the respiration may be carried on by the other. In a similar manner ulceration may proceed to destroy the lobes of one side of the chest, as in glanders, but may be checked by the mediastinum from proceeding to the other. The pleura does not, as in man, appear to take on inflammation independently of the substance of the lungs; thus the horse is not subject to pleurisy. The thymus gland, which is a considerable body in the colt, and which forms the sweetbread in calves, is hardly discernible in the old horse. It is situated between the folds of the mediastinum, but its uses are unknown.

5720. *The diaphragm or midriff* (fig. 616 *i, h*) is a very important part of the body of the horse, dividing the chest from the belly by its disk, but which is far from elliptical, extending much further backwards than forwards. Its fibres radiate from their origins to unite in one tendinous centre (*h*). In a state of rest it is anteriorly convex, and posteriorly concave; but at each inspiration these appearances are nearly reversed. (5724.) It is perforated for the passage of the vena cava, the aorta, the vena azygos, thoracic duct, and œsophagus, all which pass through it by means of three openings.

5721. *The heart* (fig. 616 *d*) is the great agent of circulation, and thus is made independent of the will; were it otherwise, man and other animals might cease to live at their own discretion. *The pericardium* is first seen surrounding the heart so completely, that it swims within it by means of a little fluid termed liquor pericardii. The heart is a composition of membranous and muscular fibres, having four principal cavities, and several openings. It is situated between the mediastinum, so as to occupy a cavity of its own, distinct from either side of the chest. Its base is in a line with the dorsal vertebræ, and its apex is directed to the left of the sternum, between the eighth and ninth ribs. Its two ventricles are immediately within its body, and its two auricles are rather without, appended to it. The left ventricle contains arterial blood, and from it originates all the arteries except the pulmonary. The right ventricle is the reservoir of the venous blood, and it receives all the veins except the pulmonary. Within the ventricles are valves to prevent the return of the blood. The auricles are less muscular than the ventricles; the left, or pulmonary, opens into the left ventricle: and the right, communicates with the right ventricle. Into the right and larger auricle the anterior and posterior cavas enter by two openings, and into the left, the pulmonary veins pass.

5722. *The circulation of the blood* may be shortly described as originating with the left ventricle of the heart, which sends its blood, by means of the great vessel called the aorta, to all parts of the body. It is received by the veins in like manner from all parts, and proceeds to return its blood into the heart by means of the two great veins called cavas, which pour the returned blood into the right auricle, which immediately forces it into the right ventricle. From the right ventricle it is again forced out into the pulmonary artery, which carries it throughout the lungs to undergo a change, and to be finally returned by eight trunks into the left auricle, which immediately empties it into the left ventricle to renew the process described.

5723. *The lungs are spongy masses* divided into right and left, with lesser divisions called lobes. Their color varies according to age: thus, in the colt they are of a light lively pink; in the full grown horse they approach to a greyer tint; and in the very old subject they are of a still deeper tone. The bronchia are continuations of the trachea or windpipe, which, dividing on its entrance into the chest, ramifies throughout the substance of the lungs; giving these masses their spongy cellular structure, in which distribution the air vessels are accompanied by ramifications of the pulmonary artery and veins. From the extreme vascularity of these parts they are very liable to inflammation.

5724. *The theory of respiration.*—By some extraordinary sympathy, the colt at birth gasps, and air rushes into the lungs before collapsed: having once felt this stimulus, by a common consent between the diaphragm and intercostal muscles, the cavity of the chest is diminished to expel the air received, and to inspire a fresh quantity; and which process is then continued through life. The body appears vitally nourished by two sources: the one through the medium of digestion, the other by means of the blood itself; which, in its progress through the body, gives out its vital principles of heat to the mass, and vitality to the muscular fibre: for unless the blood effect its part in the contractile phenomena, it will be in vain for nervous influence to exert its power. Having given out these principles, it is returned by the veins, and is passed forwards into the lungs, circulating throughout their substance, and imbibing by their contiguity or continuity with the air vessels, oxygen gas from the atmospheric air contained in them. In return for the oxygen received, carbon is given out, which passes off in the form of aqueous vapor. As the blood is renovated, so the air it acted on is deteriorated, and is therefore expired from the chest to make room for a fresh inhalation, to oxygenate a fresh quantity of blood, and thus to renovate afresh the vital powers subservient to its influence.

#### SUBJECT. 13. *The Abdomen.*

5725. *The viscera of the abdomen* includes the stomach (fig. 618 *a*); lobes of the liver (*bb*); omentum or cawl attached to the whole inferior curvature of the stomach (*c*); the spleen (*d*); the kidneys (*ee*); the rectum (*f*); the ovaria (*gg*); the uterus (*h*); the bladder distended with urine (*i*); the diaphragm or muscular partition dividing the belly from the chest (*kk*); œsophagus or gullet proceeding to the stomach (*l*); trachea (*m*); vena cava ascendens (*n*); aorta descendens (*o*), which passes through the abdomen (*aa*), as does the cava descendens (*b*); the aorta ascendens (*p*); carotid arteries (*q*); jugular veins (*r*); œsophagus (*s*); and maxillary artery, forming the most convenient situation for feeling the pulse (*t*), complete the viscera and general appearances of the horse when laid open.

5726. *The abdomen or cavity of the belly* is the largest cavity of the body, and forms an extensive oval vault, containing very important viscera, which may be considered; as, the chylopoetic, the

urinary, and the spermatic, all which are invested by a membrane called the peritoneum, which, after covering each of these organs separately, is reflected over the cavity of the belly itself. It is very strong, and very elastic, as we perceive by the effects of dropsy, great fatness, and likewise by the increase in pregnancy. The *omentum or cawl* (c) is the fatty apron which first presents itself on opening an animal's body, extending in some, as the dog, pig, &c., into the pelvis; but in the horse it is less considerable, by which he is not subjected to epistocle as they are. Its uses are unknown.

571. *The stomach and its digestive functions.* The horse has one stomach only, and that a very small one, drawing a very wide line of separation by this means between his family and the ruminants. In fact the stomach of the horse may be regarded as intermediate between the triturating muscular one of fowls, and the membranous one of the graminivora. It is peculiarly constructed to keep up this intermediate character, being partly membranous, partly muscular, and partly cuticular; in which latter formation much of its peculiarity consists, and which it shares in common with asses, rats, and mice; whose habits of living on grain give them a like claim to this wise provision. In a state of rest, or only moderately distended, its direction is across the abdomen, with its two orifices directed upwards; but the cardiac or recipient orifice, to which the oesophagus is attached, the most so; while the pyloric or expellent orifice is rather lower, and more inclined backward. The situation of the stomach is immediately contiguous to the diaphragm or great breathing muscle (fig. 618 k k), from which we are at no loss to understand why a very full meal obstructs respiration; and why it is so imprudent to gallop a horse very hard after drinking or eating fully. Small as the stomach is in a natural state, it is yet capable of great distention, as has been witnessed in stomach staggers, when upwards of half a hundred weight of undigested food has been extracted from it. The membranous portion of the stomach is gained from the peritoneum; within this is situated its muscular part, principally composed of longitudinal and transverse layers, by which its motions in digestion are regulated. Around the cardiac or recipient orifice, a strong band of circular fibres is very evident, which effectually constricts this part, and prevents regurgitation or vomiting in the horse, except under extraordinary circumstances of muscular relaxation and sympathy. It has been already shown that the anterior part of the alimentary canal, as the mouth, throat, and gullet, are lined with cuticle or skin. This cuticle is continued into the stomach, and lines nearly a half of its internal surface, whose office seems to be a more perfect comminution of the food, which the horse has no opportunity of remasticating like the ox, sheep, &c. The villous or sensible portion of the stomach is thrown into folds, so as greatly to increase its surface: here the comminuted food in its passage becomes saturated with the solvent gastric juice, and is then passed forward into the intestines.

572. *The derangements of the stomach* may be explained from its anatomy. Though small, and its sensible parts still smaller, yet it is subject to more diseases, and to more frequent derangement than is generally supposed. It has been proved to be muscular, and that its digestive functions are performed by means of its muscularity. It has also been shown that the contractile energy of the muscular fibre, is mainly gained from the oxygen derived from the blood; whatever tends to interrupt this separation, as an unhealthy state of the lungs, too quick action of them, &c. must derange the action of the stomach also. The perfection of its digestive powers is also derived from its secreting healthy gastric juice, consequently whatever interrupts this process, must likewise interfere with stomachic health, and that such health is more often impaired than is generally supposed, and that many ailments, attributed to other causes, are really dependent on an affection of this organ, experience and observation will fully evince. Out of condition is a most frequent complaint among horsemen; their horses are out of condition, and unfit for work: the appearances are various, but are all well known; yet it is seldom considered, that it is owing in every seven cases out of ten, to the stomach being morbidly affected. (5756.) It is evident that too full feeding must derange it, not only by keeping it constantly distended, and thus weakening its capacity; but by entrenching too much on its secreting office, and requiring an inordinate quantity of gastric fluid to saturate an undue quantity of farinaceous matter. The bots, that are frequently found on its cuticular coat, and are there probably harmless, sometimes displace themselves, and settle on the villous part, where they must occasion uneasiness and probable inflammation.

573. *The intestines* (fig. 616 k, l) in the horse may be considered not merely as secreting organs alone, as in man and many animals, but as really digestive organs, and continuations of the stomachic viscus. This is more particularly the case with the small intestines, and may therefore entitle them to the term of alimentary canal, and the large to that of the excremental; the former measure from twenty-one to twenty-three yards in length, and the latter from seven and a half to eight yards and a half, according to the size of the animal. The duodenum is the first of the small intestines, commencing at the pyloric orifice of the stomach; the jejunum, which is the next and larger portion, and the ilium (fig. 616 e), which is still longer, form the remainder. The alimentary

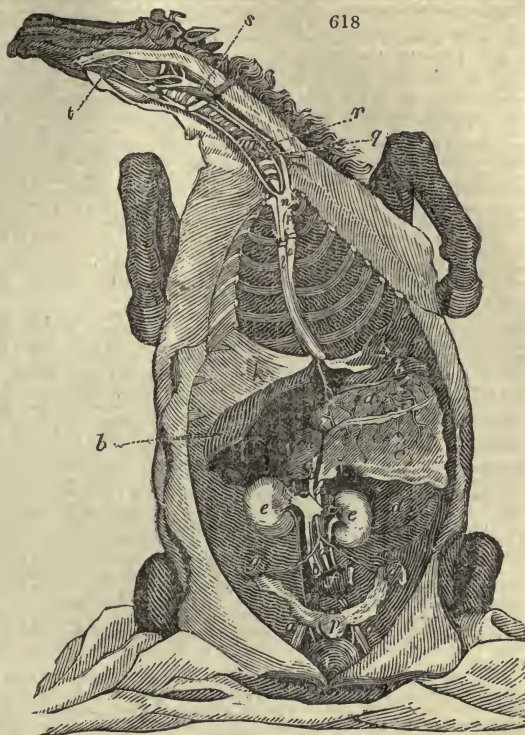

canal in its structure does not differ from the sensible part of the stomach, having like that two plans of muscular fibres, a circular and a longitudinal, by which its peristaltic motions are regulated; the longitudinal shortening the canal, and the circular diminishing its size. The alimentary part of the intestinal canal ends with this small gut, which itself terminates abruptly in the cæcum or first of the large intestines (fig. 619 a), and which intestine commences what has been termed the excrementitious canal. This entrance is effected in such a manner as to leave, by a protrusion of its surface inwards, a kind of valvular apparatus, which prevents the return of the contents.

5730. The large intestines (fig. 616 k k), in the horse are really deserving of that name, being very capacious; while in man and carnivorous animals they are little different from the small. They occupy and completely fill up the lower portion of the abdomen: the cæcum occupies the right side, and carries its blind end towards the diaphragm, which is not furnished with an appendix as the human. A careful inspection of this intestine will show that the appellation of excrementitious canal does not wholly apply to it; but that on the contrary, it performs some of the offices attributed to the smaller intestines. The colon commences small from the side of the base of the cæcum, but soon enlarging, it makes a turn around the abdomen, when contracting it ends in the rectum, and passes backwards to the anus. Along the course of the large intestines are muscular bands, which throw their surfaces into folds, and also form them into a continuation of cells (fig. 616 m). By these means, the matters are detained to be acted on more fully, and finally they are expelled in dry hardened balls.

5731. The digestive process in the horse is one of the most curious as well as one of the most important which goes on in the body. The various actions of an animal body produce relaxation and waste, which are indicated by fatigue and hunger. To restore the one, rest is required, and to restore the other, food becomes necessary. For the herbivorous tribes, vegetable matter is sought for, which being collected, is masticated by the grinders and mixed with saliva, until it becomes a softened mass, when it is passed backwards by the tongue and molar muscles, through the arch of the palate in the form of a bolus. Received into the pharynx, which rises to receive it, and the action of which forces down the epiglottis, all impediment is removed to its falling in the open funnel of the œsophagus; which having received it, the spiral fibres of the œsophagus force it inwards into the stomach. While the food remains within the cuticular part, it is acted on by pressure, but being further removed, it meets the action of the gastric fluid, by which it is reduced to a pulvaceous mass called chyme. In this state it is passed into the small intestines: for in the horse, as before observed, the process of digestion is by no means completed in the stomach, as in man and many animals. The exertions of the horse require that he should eat largely and nutritiously; but the bulky viscera of the ox would have ill suited with his necessities; for he is not only strong, but his motions are designed to be quick also: it was therefore necessary that some speciality should occur to meet these seeming discordances. This consists in the mode of digestion, which being but partially completed in the stomach, requires a less bulk in that organ, the intestines participating in the labor. A horse will eat two or three pecks of corn or ten pounds of hay at a meal, and yet in a natural state his stomach will not hold half of either. He will also drink two pails of water, when the same organ cannot hold one. What is taken into the stomach is therefore quickly passed through it, and more is required. A horse cannot fast long without injury and pain; his food does not produce a lasting effect in the constitution as animal food does on the carnivora. A dog fed once a day will thrive, and when fed every other day only, will not suffer materially; but no horse fed once a day would support himself: even oxen and sheep, as having a slower digestion and more intestinal room, can bear fasting better than the horse. As an animal destined for quick as well as great exertions, his wants prompt him to take in a moderate portion of food only at a time, which his digestive powers peculiarly fit him to convert into nutriment quickly and efficaciously, by distributing the task through a long tract of canal; instead of confining it, as in man and the carnivora, to one simple organ, the stomach.

5732. The chyme passes into the duodenum from the stomach, where it receives the addition of the pancreatic and biliary fluids, whose ducts open into that part of the intestinal tracts. Conducted onwards by the creeping peristaltic motion it passes through this long alimentary tract rather rapidly in the horse; but it remains sufficiently long to receive further additions from the secreting surfaces of the smaller intestines, and probably to have its work of division and absorption begun in it. Arrived at the larger part of the intestinal tract, it is purposely delayed to be fully strained and separated, the open mouths of the lacteals spread over the villous surface, receiving the nutritious part under the name of chyle, and the residue being carried backward, and thrown out as dung. The chylous orifices belong to minute tubes termed lacteals, which pass onwards enveloped in membranous folds termed mesentery, until uniting in one trunk called thoracic duct, their contents are poured into the heart, whereby they become mixed with and converted into blood, producing an increase to its quantity; as the alteration it receives in the lungs is an amelioration of its quality, which it has been shown is equally necessary.

5733. The liver may also be considered as a digestive organ (fig. 618 b b), inasmuch as it secretes a fluid whose office appears to be to quicken the action of the intestines; at the same time that perhaps the very matter separated tends to purify that blood which has been already distributed to the chylopoetic viscera. All other animals, except the horse, ass, and deer, are furnished with a receptacle for the bile, where it may be retained and rendered more acrid: but the horse has no gall bladder, and in his foetal state, another speciality presents itself in this organ, which is, that he is deprived of a canalis venosus, and thus the whole of the abdominal blood flows through the liver. From this simplicity of structure in the horse he is seldom affected with obstructed, or concrete bile; but the organ itself is liable, to inflammation, and also to a chronic disease of it through the medium of the stomach.

5734. The pancreas is an assistant to digestion also, as we have reason to conclude by its pouring its contents into the duodenum with the bile. It is situated behind the liver, between the stomach and left kidney.

5735. The spleen or milt, (fig. 618 d), is a spongy body situated at the greater extremity of the stomach, whose use is likewise not clearly ascertained; but has been supposed to be that of a reservoir of blood for the use of the stomach.

5736. The kidneys are two excremental glands (e e) situated in the lumbar region, the right more anterior than the left. In many brutes, as the ox, sheep, and hog, they are embedded in fat; but in the horse, dog, and the predatory tribes, they are seldom so. The structure of the kidneys exhibits an external reddish part, an internal whitish part, and a cavity called the pelvis. From this cavity passes out the duct called the ureter, and brings with it the urine which is secreted within the kidney. The ureters convey the urine to the bladder.

5737. The urine appears to be a fecal separation from the blood, and is in some measure connected with the skin in its office. Thus, when the perspiration is great, the urine is less; and on the contrary in winter, when the perspiration is small, the urine is more considerable. The kidneys of the horse are more easily stimulated into increased action by diuretics than the human or those of most other animals; and substances which would not appear potent, act with violence on his urinary organs. Thus mow-burnt hay, kiln-dried oats, &c., will produce diabetes.

5738. The bladder of the horse (fig. 618 i), is a membranous sac for the reception of the urine, it rests on the pubis, and is immediately under the rectum. It is in part muscular, by which it can expel its contents almost to the last drop. At its neck is a kind of sphincter to prevent the involuntary escape of urine, and at its posterior part it is pierced by the ureters. To the bladder is attached a membranous pipe called the urethra, which passes through the penis, and by that means ejects the urine.

619

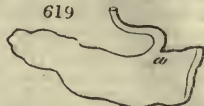

SUBJECT. 14. *The Organs of Generation.*

5739. The *male generative organs* are most of them external, on the contrary in man they are mostly internal; but in both the one and the other they are connected with the urinary organs, so that one general formation is made to answer a double purpose.

5740. The *male organs of generation* consist of the *testes* or *testicles*, which are two in number, that in case one should suffer injury, one may remain to carry on the great work of reproduction. In the fetal colt they are lodged within the belly, but after birth they descend into a bag prepared for them. The *scrotum* is this bag, whose situation is between the hinder extremities. It contains the testicles in two sacs, one appropriate to each. Each testicle is enveloped by two tunics, called *vaginalis* and *albuginea*, obtained from the peritoneum. To each testicle is attached an appendage called the *epididymis*. The *vasa deferentia* are the united trunks of the secretory vessels of the testicle continued from the epididymis. Each vas deferens proceeds to join the *vesicula seminales* of that side to run parallel with it and to terminate near it in the urethra. The *prostate glands* are in the horse two, whose use, like the hollow bodies called seminal receptacles, is not obvious, but probably they dilute the semen.

5741. The *penis* or *yard* is a long body, in one part nearly prismatic, and in another cylindrical. In the usual state the penis is hidden within the *sheath*, which is a prolongation of the skin of the abdomen. The body of the yard is composed of two cavernous flattened portions closely connected, a spongy canal, which is the urethra before mentioned as the continuation of the bladder, and the *glans* or head, which appears in the horse a distinct part. The penis is capable of being distended by means of its blood vessels, which fill its cells to turgidity, particularly under the excitement of lust.

5742. The *generating use of the male organs* is principally derived from the vivifying principle contained in the semen secreted within the testicles, and which the horse is impelled by lust to plant in such a situation as shall produce its effect in the formation of a foetus. In the act of copulation therefore, it appears that the nervous influence acts on the muscular system of the penis, whereby the arteries carry more blood, while the veins are rendered unable from some cause to effect its removal; by which the cavernous cells of the penis become filled, and the member thereby erected; when, from the friction produced by the female vagina, the penis becomes stimulated into a more exquisite sensation, with which the vasa deferentia and vesicula seminales participate, then by the assistance of the cremaster muscles, the semen and diluting fluids become pressed out, and by a convulsive effort are injected into the generative organs of the mare. The stimulus of the retained semen being now removed, the appetite becomes satisfied, the nervous influence is removed from the vessels, and the penis returns to its ordinary size.

5743. The *female generative organs* are first the *bag* or *mamæ*. In the multiparous animals, as the hog, the dog, and rabbit, these bags are numerous, and distinctly placed along the line of the abdomen; but in the uniparous, as the mare, cow, sheep, &c., one bag, situated between the hind legs, contains the secretory of the whole. In the mare there are two *nipples* or *teats*, which form excretory ducts to the milk secreted within. In ordinary cases, the milk is prevented from flowing out by valves, which open on pressure upwards: the colt, sensible of this, is observed to push up the teat with its nose; pigs and puppies with their feet, &c. The milk in different animals has different proportions of certain component parts, but in each it has those best adapted to the animal it is intended to nourish. The *volva* or *sheath* is the long oval opening immediately below the anus, at the inferior commissure of which is situated the *citoris*, whose structure is not unlike the male penis. Above this, and rather more internally, is situated the *urethra*, which in the mare is a short membranous canal. The *vagina* is a long membranous canal above the last described parts, capable of great distention; but in its natural state about 9 or 10 inches long and 2 in diameter. It is placed horizontally between the bladder and rectum, and terminates in the neck of the womb. The *uterus* (fig. 618 p) of the mare is very dissimilar to the human, being not an uniform bag; but having a body and two branching *horns*, in which, in the multiparous animals, the young are lodged. The extremity of each *cornua* has a small concealed tube attached to it called the *fallopian tube*, and a little beyond are seen the oval oblong bodies called *ovaria*, (fig. 618 g g).

5744. *Conception, pregnancy, and evolution of the foetus.* *Estrum, heat, or horsing* is in animals not constant, but returns at such periods that the evolution of the foetus consequent on it shall take place at the most convenient season of the year. The horsing of the mare produces an inflammation in the vagina and vulva, from whence are ejected what are termed the heats. In this disposition all the parts unite, and when by the injected semen pregnancy has been produced, a vesicle from the ovaria enters the fallopian tubes; and by this means becomes deposited in the womb to be nourished into maturity. In its residence within the womb, it is covered with expansions from the neighboring parts; and it derives its nourishment from a communication with the mother by a fleshy tube called the umbilical cord, and thus situated, it swims within a fluid called the liquor amnii: so circumstanced, the foetus continues to grow, until the distention it occasions, becomes too great for the capacity, when the muscular fibres of the uterus, powerfully assisted by the diaphragm and abdominal muscles, contract, and thus force both the foal and the membranes into the world.

5745. The *new born foal*, on its entrance into active life, finds its organs of immediate necessity in a full state of capacity. Unlike the infant, it is far from indigent, but can run and perform the common phenomena of an animal with dexterity and ease. Its powers are however not sufficiently developed to enable it to live independent: it has therefore a necessity for seeking support from the mother, from whose person it derives its food in the form of milk; and it may therefore be now considered in some measure as carnivorous. Gradually it becomes fitted to perform all the more matured functions, and when fully able to counteract its own wants, it sympathises only with itself; when the parent's care being no longer necessary, lactiferous secretion ceases, her generative organs prepare anew for the same great work, and she again feels estrum or heat.

5746. The *period of gestation* varies in different mares, one hundred and two mares were observed by Tessier, of which 3 foaled on the 311th day, 1 on the 314th, 1 on the 325th, 1 on the 326th, 2 on the 333th, 47 from the 340th to the 350th, 25 from the 350th to the 360th, 21 from the 360th to the 377th, and 1 on the 394th day: which gives a latitude of 83 days in the time of gestation.

SUBJECT. 15. *The Foot.*

5747. The *feet of the horse* present in their united functions a series of springs with great complexity of structure. An unreflecting observer considers only the horny box, and perhaps attaches as little merit to its mechanism, as he would to a well turned wooden leg of a man. But a little examination will convince him that all the complexity, all the admirable mechanism displayed in the assemblage of four fingers and a thumb, are here concentrated within this horny box and its appendages. As the parts which compose the hind and the fore feet do not materially differ, a description of one foot will serve for the whole.

5748. On examining a perpendicular section of the foot and pastern (fig. 620), there appears the coffin-bone (a), the navicular or nut bone (b), the coronary or little pastern bone (c), the larger pastern

bone (*d*), the back sinew or great flexor tendon of the foot (*e*), the same tendon sliding over the navicular bone (*f*), its termination or insertion into the bottom of the coffin bone (*g*), the elastic matter of the sensible frog (*h*), the insensible or horny frog (*i*), the horny sole (*k*), which includes the parts of the sensible foot; the outer wall of the hoof (*l*), the elastic processes (*m*), the attachment of the extensor tendon to the coffin bone (*n*), and its attachment to the coronary bone (*o*), which completes the section.

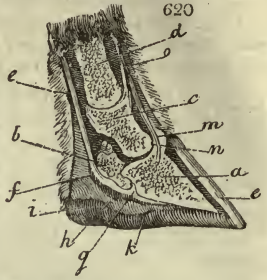

5749. *The coffin bone* (fig. 620 *a*) adapts itself to the form of the hoof, or rather is adapted by nature to this eligible form. The eminence in front receives the insertion of the tendon of the great extensor muscle of the foot, whose upper attachment is to the humerus or arm bone where it is fleshy, but as it passes onwards, it becomes tendinous, expanding over every joint, both to prevent friction, and to embrace and give attachments to each bone, by which a simultaneous movement of the whole limb is made. In the hinder limb, this extensor and its two lesser adjuncts arise from the tibia and in part from the femur. To the sides of the coffin bone are attached the lateral cartilages, and around its surface are marks of the attachment of the laminated substance.

5750. *The coronary or small pastern bone* (*c*), articulates with the coffin at its posterior part, and articulating also with both these is the *navicular or nut bone* (*f*), whose attachments to them are effected by ligaments.

5751. *The hoof is conical*, or rather, as Clark observes, slightly truncated, and is a secretion as well from the vascular parts of the foot as from the skin, as our nails are from the portion of skin called the quick. The structure of the hoof is firm and fibrous; externally plane and convex, but internally concave and laminated. The *quarters* are the lateral parts. As the horn approaches the heels it becomes soft, and is reflected inwards. The heels are parted by the *horny frog* (fig. 621 *b*), and without the frog on each side, the hoof infects its fibres to form the bars which are seen on the under surface (fig. 621 *c*).



In a healthy foot (fig. 621.) the heels are round, wide and smooth (*a a*), the frog fully expanded (*b*), the bars or binders distinct (*c*), no corns in the usual angle (*d*), the sole broad, and concave (*d*). In a diseased foot (fig. 622.), the heels are high and drawn together by contraction (*a a*), the frog narrow and filled with fissures from contraction and thrush (*b*), and the sole greatly shortened in its transverse diameter which is morbidly counterbalanced by the increased heights in the truncated form (*c*). When the hoof is removed, the *sensible or fleshy sole* (fig. 620 *k*), above which it immediately lies, presents

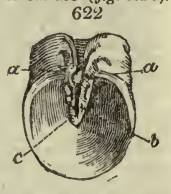

itself, covering the whole of the horny sole, except so much as is taken up by the *sensible frog* (*h*). This part is exquisitely sensible and vascular, and thus we learn why injuries to it from punctures, produce such serious effects; and why very slight pressure from contraction of the hoof gives so much pain. The sensible frog and the sensible sole form the insensible frog and sole; but when from pressure, too much moisture, or other causes, the sensible frog, instead of forming horn, secretes pus or matter as in thrush, the structure of the whole becomes injured, and the horny frog, thus losing its support, gradually wastes and decays. It is therefore evident that no thrush can be entirely harmless, as is erroneously supposed. Above the sensible frog and sole, is the great flexor tendon, or back sinew, inserting itself into the vaulted arch of the coffin, (fig. 620 *e*.) This important tendon arising from its parent muscle above the knee, whose origin is taken from the humerus and ulna, in its passage unites with an assistant flexor, but which latter is principally distributed to the pastern bones; while the *perforans*, so called because it is perforated by the assistant flexor tendon, is inserted into the vault of the coffin. In the posterior extremities the attachments of these two leading flexors, and a smaller *lateral one*, are from the femur and tibia.

5752. *The sensible laminae*. Around the surface of the coffin bone, it has been noticed that there are linear indentations to which about five hundred semicartilaginous leaves are attached. Each of these is received between two of the horny lamellæ which line the interior of the horny hoof: and when it is considered what a vast surface of attachment is formed by these means, the strength of the union will not be wondered at. No violence can separate these parts, and their use, as so many springs to support the actions of an animal, at once weighty, strong, and extremely agile, must be apparent. The vessels and nerves of the foot are derived from the metacarpal arteries, veins, and nerves, which pass behind the pastern, when the main trunks divide to proceed to each side of the foot, and are ramified from thence throughout. It is a division of the metacarpal nerve on each side of the lesser pastern, or of the larger, as occasion suits, which forms the *nerve operation*, now in vogue as a remedy for founder.

SECT. V. *Of the Diseases of the Horse.*

5753. *The diseases of the horse* are as numerous and as important as his complicated structure and the artificial state of his present mode of life would lead one to expect. Until of late the treatment of these diseases was confined to the hands of ignorant farriers, presumptive grooms, or shoeing smiths; and the fate of the animals was commensurate with the wretched treatment they were subjected to. The establishment of a school for the veterinary art, has disseminated an improved practice, and spread improved practitioners throughout the country; and we would earnestly recommend an application to one of established reputation in all cases of difficulty and danger. But as it is not always that such a one is within reach, to enable the agriculturist to have in his own hands the means of informing himself, or of being a check on others, we submit a concise view of the diseases of the head, neck, trunk, and extremities, preceded by some general observations.

SUBJECT. 1. *General Remarks on the healthy and diseased State of the Horse.*

5754. *Condition of horses*. Being in condition, in stable language, signifies not only perfect health internally, but such an appearance externally, as the philosopher would call 'unnatural, or at least artificial': while the amateur considers it as an essential requisite to the other qualities of the horse. This external condition is denoted by a sleek, short, shining coat, with a degree of flesh neither bordering on fatness, nor emaciation. Even in this sense of the term, *condition* must be varied according to the use



of the animal. In the cart horse, provided there be sleekness of coat, looseness of hide, sound wind, freedom from grease or swelled legs, with good digestion; a fulness and rotundity of bulk, instead of detracting from his beauty or impeding his exertions, will add to the one and assist the other. In the coach horse, the hackney, the hunter, and the racer, a different condition is expected, varying in different degrees from that of the cart horse. In both cart horse and racer, it is equally necessary that the various internal organs should be in a state to act uninterruptedly for the benefit of the whole; but in addition to this, it is necessary to the racer, that the greatest possible quantity of animal fibre should be condensed into the smallest possible bulk; and that the absorption of all useless fat and other interstitial matter should be promoted by every possible means, as essentially necessary to unite lightness of body, with full strength and elasticity. It is in the attempts to produce such a state in its full perfection, that all the *secrets of training* consist: but whether a total departure from natural rules, by unnatural heat, deprivation of light, stimulating food, restraint from water, and excessive clothing, are best calculated to promote it, admits of much doubt; and it is to be observed that the dawn of reason and science appears to be shining through the crevices of these darkened casements; for even at Newmarket the system has lately much relaxed from its artificial rigor.

5755. *To bring a horse into condition*, not only should the purposes he is intended for be taken into account, but also his previous state. If he be taken up from grass with much flesh on him, it is evident that what is required is to remove the soft interstitial matter it may be supposed he has gained by green food, and to replace it by hard flesh; and also to produce a sleekness of coat and beauty of appearance. To accomplish these ends, the horse should be accustomed to clothing and the full heat of the stable by degrees only; and also by degrees only to the meditated change of food; which is best done by mashes. In two or three days a mild dose of physic may be given, during all which moderate exercise only should be allowed, as walking, but which may be continued two hours at a time. After the physic has set, begin to dress his coat, increase his exercise and his food, and accustom him to an increase of warmth. In four or five days time again mash him for two days, and give a second dose of physic, a very little stronger than the first. (5875.) After this, still further increase his warmth, his exercise, and his food, by which his belly will be taken up, his flesh will harden, and his coat will begin to fall. A third dose of physic, or urine balls, &c. are only necessary in the training of hunters, &c., and even in these, a gradual increase of exercise, rather long continued than violent, with proper food, will effect the end, if not so quickly, more beneficially to the animal. *To bring a lean horse into condition*, a somewhat different plan should be pursued. If from grass, still mash him for a day or two, by no means stint him in his water, and with his mash let corn be also soaked. If corn be speared or malted, it will produce flesh sooner. But even here, give the horse moderate walking exercise, and if he be not too much reduced, add a mild dose of physic to prevent his heels flying, or his getting hide bound by the increased food; but if great emaciation forbid the physic, give him nightly an alterative. (*Vet. Pharm.* 5881. No. 1.) As his appearance improves, gradually harden his food and increase his exercise.

5756. *Diseased condition of horses*. What has been already said relates to that alteration from one state to another, neither being an unhealthy one, which custom has rendered necessary; thus a man in training for running or fighting, and a man out of training, are both considered equally healthy. But there are circumstances that produce a *morbid state of condition*, different from all these. It is common to hear persons say "my horse is sadly out of condition, and I cannot tell either what is the matter with him, or how to get him into better case." Various are the causes that may produce this: a sudden alteration of the food, or temperature, or of habits altogether, may become a cause. Removing a horse from grass to a heated stable, full feeding, and hard exercise will often do it: therefore these changes should always be gradual. Bad food, as mow-burnt hay, musty oats, beans, &c., likewise mineral waters, foul air, &c., are frequent causes. Diabetes, or profuse staling, is often brought on by these means, and the condition of the horse becomes greatly reduced. It is requisite, therefore, to enquire whether any of these errors are in existence, and to immediately remove them: but it often happens that the stomach has become relaxed and the hide become bound; neither of which readily remove, even though the original evil may be amended. When the relaxed stomach has produced lampas, treat the mouth as described under that disease (5771.), but the stomach itself must be principally attended to. First mash and give a dose of physic; after it has set, commence the treatment, if the horse be of a full habit, by a moderate bleeding and a nightly *alterative* (*Vet. Pharm.* 5881. No. 1. or 2.) But if he be not in full, but in low flesh, commence by a daily *tonic*, (*Vet. Pharm.* 5882. No. 1. or 2.) which will gradually remove the swelling within the mouth, and loosen the hide. A sudden cold applied to the skin often brings on a want of condition with *surfeit*. In which cases bleeding, nightly alteratives (*Vet. Pharm.* 5881. No. 1. or 2.) with or without an assistant dose of physic, as the habit of the horse may require, constitute the proper treatment. Worms form another cause of morbid condition which are to be removed as described (5809.). *Excessive fatigue* is also productive of a bad state of condition, which often proves very obstinate. Turning out to very good grass is the quickest cure, and when that is impracticable, soiling in the stable, or feeding with carrots, parsneps, beet root, &c. will be food restoratives; as medicines give tonics daily. (*Vet. Pharm.* 5882. No. 1. or 2.) It will be only necessary to add, that in considering the state of a horse's condition, the effect is apt to be mistaken for the cause, and the symptoms for the disease. Hide bound and lampas are not in themselves any thing more than effects, or symptoms; the former being commonly, and the latter being always dependent on a deranged state of the stomach: both are therefore to be treated accordingly. Exactly the same will apply to all the other symptoms of morbid condition.

### SUBJECT. 2. *Inflammatory Diseases of the Horse.*

5757. *The inflammatory diseases of the horse* are numerous, but his fevers are few; a febrile state being generally brought on by the inflammation of some important organ. Inflammation may be considered as general or diffused, and local or confined, and both seem to arise from an affection of the blood vessels, and perhaps from a peculiar state of the blood itself.

5758. *General or diffused inflammation* constitutes fever or extensive inflammatory affection, and appears to consist in an increased action of the heart and arteries, accompanied with an increase of heat. In some instances where the fever is purely symptomatic, and dependent on the inflammation of some important organ, as of the lungs, or the intestines, the circulation appears retarded rather than increased, from interruption arising to its passage through the heart.

5759. *Local or confined inflammation* is also dependent on an affection of the blood vessels, but confined principally to the blood vessels of the part affected. It is betokened by redness in the skin, tumor or swelling, heat and tenderness, with pain. Inflammations, both diffused and local, are brought on by excitements, such as over-feeding, excessive heat, the reaction produced after cold, and the reaction produced by inordinate exertion. Those more exterior, arise from injuries, the application of im-

proper substances, &c. Inflammations terminate in various ways; but it is to be remarked, that in consequence of the very large circulatory system in the horse, his febrile affections rage higher, and terminate sooner than in man. The usual termination of inflammatory affections in the horse, are by resolution, effusion, suppuration, and gangrene. Schirrus is not at all a common termination of inflammation in the horse.

5760. *Inflammation of the brain (phrenitis), brain fever, phrensy fever, staggers, mad and sleepy.* There are few diseases more likely to be mistaken by inexperienced farriers than this; it is not to be wondered at, therefore, if indifferent persons should be led into error by it. It appears in two forms, a violent frantic one, and a sleepy lethargic one, and the latter appearance is also common to a disease, not dependent as this is, on idiopathic inflammation of the brain; but on a paralytic affection of the stomach, and thence it is called stomach staggers. This latter affection, however, may be distinguished from the former by attending to the color of the eyelids, nose linings, mouth, &c., which in stomach staggers are usually more yellow than red: whereas in sleepy staggers, they are more red than yellow. Inflammation of the brain shows itself in general cases by disinclination to food and motion, drowsiness, accompanied by a heaviness and closing of the eyelids, with moisture and redness of them; and also of the linings of the mouth and nose. Sometimes these symptoms increase until the horse becomes comatose, and after a few frightful struggles, he sinks to rise no more. In these cases the pulse is apt to be oppressed instead of increased. But most frequently after the first stages he becomes furious, plunges about, and is vicious to himself and others, approaching to a state of madness, in which state he continues till he sinks from his own exertions, when he rises again to renew his violence.

5761. *The causes of staggers may be various:* the immediate are either an original accumulation of blood within the brain, or the translation of the inflammation of some organ to the brain: as a remote cause it is often brought on by too full feeding, without sufficient exercise, and particularly in horses at one time working very hard, and at another suffered to remain inactive; but which horses, whether used, or not, are equally fed. Sudden cold, violence, &c. may bring it on.

5762. *The treatment of staggers should be begun by abstracting a very large quantity of blood promptly, by opening both jugulars, and letting the horse bleed to the amount of ten or even twelve quarts; repeating the same until the delirium ceases.* After the first bleeding, back rake, throw up a laxative clyster (*Vet. Pharm.* 5895.), blister the head, promote a current of free air in the stable, and treat altogether as directed under other febrile affections.

5763. *Locked jaw, stag-evil, or tetanus,* arises from cold, excessive fatigue, sometimes perhaps from worms, but more often from a wound of some part, as pricks in shoeing, &c. Such wound is seldom in a recent state; but after two or three weeks' continuance, sometimes after it has healed even: it follows docking, gelding, and nicking frequently; and is preceded by a flabby unhealthy state of the wound. It appears as an affection of the brain, which transmits its morbid irritation, particularly to the nerves attached to muscles, by which they become cramped, or may be considered as in a high state of action, giving the horse a peculiar look of energy, as though immediately stopped from full speed; with his nostrils extended, his head raised, and nose carried forward; his legs straddle wide, and his tail is cocked and quivers, as after violent exercise. The jaws will now be found, if not closed, yet nearly so, when he is called *jaw set*.

5764. *The treatment is not often successful, but, however, it is sufficiently frequent that it is so, to deserve the utmost attention.* Blaine informs us that enormous bleedings have succeeded; but he places his principal dependence on the application of cold by the means of ice, or of constant dashing with cold water, with an active blister applied the whole length of the spine. Balls of camphor and opium, to the amount of two drachms of each, may be given every three hours. If any room remains in the mouth, the ball may be passed up by means of a stick, or it may be given as a drink by means of a syringe; and even when the mouth is entirely closed, he informs us we may give a drink by the nostrils. Moorcroft used cold also. Fearon, on the contrary, has experienced benefit from a bath, heated to ninety degrees, and kept at that temperature for three hours. White recommends camphor and opium; Wilkinson of Newcastle has been very successful by keeping up heat and stimulus over the skin in general, by means of newly stripped sheep skins put on hot. Perhaps if the body were previously rubbed with oil of turpentine one part, and common oil two parts, it might assist Wilkinson's plan. When locked jaw arises from nicking, it might be prudent for a veterinary surgeon to dissect down on the nerves of the tail, and divide them; and when from nicking, it would be advisable at once to cut off another portion of the tail, which practices in both instances would afford a moderate chance of saving the animal. It is necessary further to remark, that it is of great consequence that the bowels be kept free from fæces, by raking and clysters. With regard to the latter they are very important in this disease, as a medium, commonly the only one, of giving support. A horse has been kept alive on nourishing clysters alone, for seven or eight days. (*Vet. Pharm.* 5897.)

5765. *Catarrhal fever, epidemic catarrh, influenza, distemper, cold, morfoundering, &c.* These names apply to one common disease, which often in rainy, variable seasons, appears as an epidemic, and affects thousands of horses at once. It is observed to be particularly prevalent in this form in the spring of some years, more than of others. It is not contagious, like the more malignant form, but is brought on as an epidemic by the same causes being applied to nearly all subjects alike; which are alternations of heat with cold, moisture and dryness, &c. In crowded cities and large towns it is more prevalent than in more open situations, and it is more frequently found in the young than in aged horses. Where it does not exist as an epidemic, it is brought on by an accidental cold taken. It is of great consequence to distinguish it from pure inflammation of the lungs, with which it is very apt to be confounded; and which mistake is often a fatal one, from the treatment being in some essential particulars different. Inflammation of the lungs commences by a short cough, without much other disturbance to the health, than the pain it gives the horse to cough, but which is often so considerable as to make him stamp his feet while coughing. If a horse in the distemper coughs early, it is not a hollow, harsh sounding, and distressing cough of this kind; if he expresses uneasiness, it is principally from a sore throat, which is very common in distemper, but by no means common in pneumonia. The sore throat in distemper gives the horse a disposition to refuse his food, or he chews it and lets the quid fall without swallowing it. He refuses water, particularly if it be placed on the ground; his cough is quick, short, and usually sounds more moist than harsh and dry; but though common, this is not invariably the case; his eyes are heavy and moist, his breathing is quickened, and his ears and legs are alternately hot and cold. His nose on looking into it is redder than usual, and sometimes his glands, as well submaxillary or jaw glands, as his parotid or vives, are tumefied. On the second or third day excessive weakness comes on; the cough becomes more painful, the pulse is quickened, and the nose begins to run. After which the horse either runs off the disease by this suppuration, or it goes on to destroy him by the height of the fever, and degree of weakness produced, or by suffocation from water in the chest. Now and then, although recovery takes place, an obstinate cough is left; and in a few cases the disease terminates in glanders.

5766. *The treatment may in some cases be cut very short; for as in almost every instance a shivering fit begins the disease, so when many horses are in a stable, and the disease is very prevalent, those who have not been attacked should be watched, and the moment such an attack does take place, give of sweet spirit of nitre, or when not at hand of spirit of hartshorn, an ounce, in a pint of sound ale. Exercise the horse briskly, then well hand rub him, clothe him warmly; and it is more than probable that the disease will be cut short. But should it proceed, or should the disease have gone on unobserved to the appearance of the symptom, detailed, begin by bleeding moderately, if the horse be not already*

weak; or if there have not appeared the running of matter from the nose. If there have, the bleeding had better be dispensed with, unless the fever appear, from the quick full pulse and redness of the inner surface of the nostrils and eyelids, to be still so considerable as to require it; in which case we must not be deterred from one moderate bleeding; and which, if the febrile symptoms do not abate, may be even repeated. It will, however, in general cases, be advisable to avoid bleeding after the second day of the attack, or after the running has appeared from the nose, or after considerable weakness has come on. In all cases a very cool temperature is essentially requisite: hot stables, or hot clothing are very pernicious; but particularly the former. A hood is not improper over the head, because it encourages the running to make an early appearance; and for this reason a warm mash may advantageously be hung round the neck three or four times a day. Before the running commences, give night and morning the fever powder (*Vet. Pharm.* 5909. No. 1. or 2.) in a mash or drink; after the running has come on, or as soon as the weakness has become considerable, give night and morning either of the fever drinks. (*Vet. Pharm.* 5910. No. 3. or 4.) Malt mashes, when the weakness is great, are proper; at other times bran mashes with plenty of chilled water are best. To relieve the throat, rub the outside with mild liquid blister, (*Vet. Pharm.* 5894.), and if the weather be warm enough to allow it, two or three hours turning out in a field each day is proper. Green meat in the stable, when it can be procured, should likewise be given.

5767. *Malignant epidemic, murrain, or pest.* Now and then the distemper or influenza assumes a character of uncommon malignance, which is happily not frequent here, but not infrequent in continental countries, sweeping off a third of the horses and kine, without any means being found sufficient to arrest its progress. In these cases it is found highly contagious, attacking almost all the horses as well as cattle within its sphere of action, or which communicate with each other. Dr. Layard, and Osmer, English writers of established reputation, noticed the appearances of this disease long ago; and their descriptions are not different from the milder kind noticed (5763.) but in degree. The throat is intensely sore, and the mouth ulcerated; the glands of the head swell, and sometimes these and other parts suppurate and burst. The matter from the nose is bloody, and the stench intolerable; the weakness is also peculiarly great, and shews itself early.

5768. The treatment recommended by Blaine is the early use of malt mashes; even ale is indispensable. Green meat should be allowed and a very cool stall is necessary, having a free communication with the open air. As medicine, three doses are necessary, every day, of the malignant epidemic fever drink (*Vet. Pharm.* 5912.); half a pint of yeast with a pint of ale has been given, with good effect, three times a day; also, to prevent the infection from spreading, fumigate the stables and all the outhouses with the preventive fumigation (*Vet. Pharm.* 5913.)

### SUBJECT. 3. Diseases of the Head.

5769. *Epilepsy, megrims, sturidy, or turnsick,* are epileptic attacks of greater or less violence, and which are apt to be confounded with the accidental strangulation that sometimes takes place, from a collar too tight, or from driving a horse hard up hill, &c. The epileptic fit makes its appearance by a sudden stop; if the horse be in action he shakes his head, looks wild and irresolute, but after some time he proceeds; when more violent, he suddenly falls down, is convulsed, dungs and stales insensibly, and remains some time before he recovers. This disease, like staggers, is generally the consequence of too full a habit; and is, therefore, best relieved by bleeding, and a more moderate diet; and, where it is convenient, a run at grass should be allowed to alter the habit.

5770. The diseases of the horse's eyes are not numerous, but they are very destructive. The principal are ophthalmia and gutta serena.

5771. The *ophthalmia, lunatic, or moon-blindness,* is a very peculiar disease among horses, affecting their eyes generally about their full growth, but sometimes later, and seldom earlier. It is but little known among mules and asses, and unknown in oxen and sheep. It does not, however, appear to be a disease natural to the horse, as wild, or even horses little subjected to artificial restraints, are not observed subject to it. But among others, it is become so common as to have the tendency handed down in the breed; the progeny of some stallions being more prone to it than others. It is often very sudden in its attack, the eyelids being found swelled and almost closed to avoid the light; they are also very red within, and the haw is half drawn over the surface; the tears flow down the face perpetually, and the whole head is hot; now and then these appearances come on gradually. The suddenness of the attack makes the complaint to be attributed to accident, as blows, hay seeds within the eye, &c., and it is frequently difficult to get the owner of such a horse, to believe that a constitutional attack, as it usually is, can come on so suddenly. Sometimes as it comes on, so it goes off as quickly, the eye from being opaque and milky, in twenty-four hours becoming clear and almost well. When such an attack has taken place, even if nothing be done, the horse sooner or later amends, and the eye or eyes, for it is sometimes one and sometimes both that are so attacked, become again clear and well, and remain so an indefinite period, from five or six weeks to as many months. Another attack, however, sooner or later follows, to which others succeed, each leaving increased milkiness on the outer coats, and some dimness within the pupil, either speck-like or diffused; and finally the horse becomes blind from *cataract*. When one eye goes blind totally before the other, it is often a means of preventing the future attack on the remaining one; which has given rise to a custom of putting out one eye to save the other, and which has succeeded. As this is a constitutional disease, brought on by artificial habits, as over exertion, close unhealthy confinement, and heating food; so it is clear the abstraction of all these are necessary to remove the complaint, and to prevent a recurrence; but particularly the close, dark, and unventilated state of the stable should be attended to, as well as the removal of the litter, which retains the volatile alkali of the urine, and irritates the eyes most injuriously. The food should be mild and cooling, and the exercise moderate, but long continued. Under the height of the attack, however, rest is advisable, with moderate light, which may be still further moderated by keeping over the eye or eyes a thick cloth wet with gouldard water. (*Vet. Pharm.* 5906.) Sometimes one quarter of vinegar to three quarters of water has been found a useful application, and whichever is used, the eyes and eyebrows should be kept continually wet with it, which by exciting evaporation will keep the part cool. A seton may be introduced under the eye or jaw. In some cases, blistering the forehead or cheek is found useful; but in every instance bleeding is proper, which should be repeated until the disease lessens. When the horse is very full and gross, physic and alteratives assist the cure. When blistering is used in any part near the eye, the greatest care is requisite to prevent the blistering matter from being rubbed into it.

5772. *Gutta serena or glass eyes,* so called from the peculiar glassy appearance of the eye, arise from a paralysis of the optic nerve. As the eye is not materially altered in appearance, a horse often becomes blind without its being noticed, until his cautious stepping, quick motion of his ears, &c., give notice of the case. On examination it will be found that the pupil remains dilated, however great the light, and the eye is irrecoverably lost. In the very early stages, blisters to the forehead and stimulants to the eyes, (as *white vitriol a drachm, water four ounces,* may be tried, but with faint hopes of success.

5773. *Pole evil.* This complaint commonly requires the attendance of an experienced practitioner; but the prevention is often in the power of owners, and others about horses; and to this point we shall particularly direct their attention. Pole evil is commonly the effect of accident. Repeated small blows of the manger, or continued pressure from hanging back on the halter, &c., will, if not remedied, produce swelling at the nape of the neck with some tenderness. In this early state, if the collar be removed and the part be kept continually wet with vinegar and water, the swelling will often disperse; but if, in spite of this, it proceeds to suppuration, let a vent be made for the matter by a seton (5868.) so that it may readily flow out. Introduce nothing healing, but encourage a free discharge, and it may

yet heal at once. When such is not the issue, the disease attacks the ligaments; sinuses form, and the matter burrows under the skin and muscles, when a seton must be introduced from the opening above and should be brought out at the bottom: the seton should be then daily wetted with the liquid blister. (*Vet. Pharm.* 5893.) Should this plan fail, escharotics will be required in the form of *scalding mixture*. (*Vet. Pharm.* 5917.)

5774. *Strangles, vives, or ives*. This disease has been likened to the human measles, because it usually attacks every horse, and most of them at a young period, between three and five years; it is fortunate when it attacks colts at grass, as it seldom occasions inconvenience, and which has led some persons into error by turning their horses out as soon as attacked; but it is not found that stabled horses, thus turned out, pass through the disease more mildly, but the contrary, except the disease exists under its very mildest form. White has conjectured that colts breeding the strangles while at grass, are afterwards exempt from glanders, but this wants confirmation. Prosser has also affirmed, that inoculation by the matter of strangles, is good, because it mitigates the complaint, and renders the horse not liable to any future attack; but the practice has never gained ground: when strangles occurs in the stable, and now and then also in the field, it proves a severe disease, and shews itself under the appearance of a cold, with cough, sore throat, and swelling of the glands under the jaws, or behind and under the ears. Sometimes there is not much external swelling, and the tumors break inwardly, and nature effects a cure; at others they break outwardly, and the disease runs off that way, and sometimes the swellings disperse either by nature or art, which breeders think unfavorable, as they suppose it renders the animal liable to a future attack, but many so treated, pass the remainder of their lives without more affection.

5775. *The treatment of strangles*. When the swelling lingers, and neither comes forward or recedes, poultices are preferable to fomentations, which, by leaving the horse wet, promote evaporation and produce cold. Peal recommends blistering the part, as the best means of promoting suppuration. The horse should be kept very cool, and bran mash with warm water should be his principal support, unless the complaint last long, and produce much weakness, when malt mash should be substituted; bleeding is only advisable when the early symptoms are violent, as heaving at the flanks, extreme soreness of throat, with much swelling around it, and considerable cough, in which case, bleeding and fever medicines are proper.

5776. *Vives, or ives*, is supposed to be a relic of the latter complaint, and it does appear now and then that after the strangles, the parotid or vive glands do remain enlarged (5794.), which occasions the disease in question; resolution may be attempted by mercurial frictions, suppuration should be avoided, otherwise the gland may be destroyed.

5777. *Diseases of the mouth, lampas*. All horses, but particularly very young ones, are liable to enlargement of the rugæ or ridges of the palate, dependent not on any local disease confined to the part itself, but occasioned by an affection of the whole passage of the mouth, throat, and stomach. It is usual to attend to the part only, which is scarified or burnt to little purpose, when a mild dose of physic, or gentle alteratives, would prove more certain expedients; to which may be added rubbing the part with bay salt, or with vinegar.

5778. *Bride sores*. When the bit in colt breaking, or in hard pulling horses, has hurt the bars, care is requisite to prevent the bone becoming carious. Touch daily with ægyptiacum, and cover the bit with leather, unless total rest can be allowed.

5779. *Diseases of the teeth* are fully treated of under the anatomical description of the bones. (5636.)

#### SUBJECT. 4. Diseases of the Neck.

5780. *Fistulous withers* are brought on usually by pressure from a saddle with too low or narrow a tree, and what has been said both with regard to prevention and cure on the subject of pole evil, applies here also. (5668.)

5781. *Sore throat* is common to horses in colds, in influenzas, and in strangles. (5765. 5774.) In every case, the horse finds great difficulty in reaching every thing that stretches his neck downwards or upwards; his water therefore should be held to him, and his hay should be pulled for him: omission of these services greatly aggravates the sufferings of horses laboring under sore throat.

5782. *Swelled neck*. A very serious swelling sometimes follows on bleeding with a rusty or poisoned lancet, or fleam, and sometimes from causes not apparent. (5878.)

#### SUBJECT. 5. The Chest.

5783. *Inflammation of the lungs* is a disease to which the horse is peculiarly liable, as we might *a priori* suspect, from the vast dimensions of his circulatory system, and the vast alteration from a natural state to which we subject him, and thereby increase his pulmonary circulation.

5784. *The causes* are these deviations remotely, but the immediate attack is generally brought on by sudden cold, acting on a heated surface, and thus it is that knackers and collarmakers in frosty weather expect a glut of horses that die from this disease. Hard riding is a very common cause, and high feeding also; it often commences slowly, a hard dry cough has been slightly noticed, but occasioning no alarm for two or three days: gradually, however, the cough appears to give the horse pain; he occasionally shivers, and his ears and feet feel colder than the rest of his body; he heaves at the flanks, and the lining of his nose is inflamed, and his eyelids also: the appetite now becomes affected, and although there is not much apparent pain, except when the horse coughs; yet there is much anxiety of countenance present. The pulse is usually small but quick; if in this state the horse be taken out and exercised quickly, it is almost always fatal to him: it likewise happens that this complaint is sometimes mistaken for distemper, and from a fear of profuse bleeding, the only remedy that is to be depended on, is omitted, and the horse is lost. At the veterinary college, in these cases, a small dose of aloes is given every six hours, and after being bled and rowelled, the horse is turned out in the open air; and it is affirmed that many recover from this treatment. Certain it is that the stable in which a horse is placed in this disease can hardly be too cool; but when entirely turned out, his feet and legs cannot conveniently be hand-rubbed, or bandaged up to promote circulation; neither can we blister a horse when turned out, so conveniently; and on blistering we depend as the second source of cure.

5785. *The treatment* is to be commenced by attempts at lessening the action of the arterial system by early and large bleedings, as seven or eight quarts from a large horse, and which should be repeated in five or six hours if he be not relieved in his breathing. Immediately rub into the brisket, on the chest, and behind the fore legs, the blister (*Vet. Pharm.* 5890. No. 1.). Give half a dose of physic, and assist it by mashes and warm water, which, if not readily taken, horn down. Back-rake also, and throw up the laxative clyster, (*Vet. Pharm.* 5895.). Avoid all exercise, clothe moderately, allow a free circulation of cool air through the stable, and rub the legs frequently, and when not under this process, keep them handaged up to the knees with hay-bands or woollen cloths. The terminations of this complaint are various. It is not uncommon for the horse to appear better, to eat and to drink, and to excite every hope of a perfect recovery; but on some sudden exertion he falls down and expires. On examination after death, it is found that effusion of a large quantity of serous fluid has taken place in the chest.

5786. *Thick wind* is another termination of *pneumonia*, by leaving the bronchial passages charged with coagulated blood. Moderate exercise and soiling in the stable with mild mercurial physic, form the best modes of treatment; but it frequently happens that the cough resists all these, and terminates in broken wind.

5787. *Roaring is also a termination of pneumonia*, in which case the lungs are not affected, but congealed blood, under the name of coagulable lymph, remains in the trachea or windpipe, and obstructs the free passage of the air; by means of which the roaring noise is made. It is in vain to expect a cure: blistering the throat sometimes slightly relieves it.

5788. *Chronic cough is also a termination of pneumonia*, and appears dependent on a peculiar irritability the disease leaves in the bronchial passages, which are found afterwards incapable of bearing any sudden alteration of temperature: thus horses with this kind of cough are excited to it as soon as the stable door opens, and by every exertion, by drinking, by eating, and, in fact, by any thing that alters the situation of the body, or is new to the part. But besides pneumonia or inflammation of the lungs producing it, it is often brought on likewise by gross feeding, which, weakening the stomach, impoverishes the blood, and thus injures the lungs which are fed by that blood. Worms also by the same means are a cause of chronic cough. It is thus that we expect to derive benefit by mediums acting on the stomach. Green food is often found useful, but particularly carrots. The hay should be excellent in quality and small in quantity; and it will be found that soiling in the stable, but particularly a course of carrots, forms a better plan of treatment than turning out. If worms be suspected, treat as under that head. (5809.) Formule of chronic cough balls are seen in the *Vet. Pharm.* (5900.)

5789. *Broken wind is also sometimes brought on by pneumonia*, and sometimes by occult causes. It is often occasioned by over-exertion after full meals, in which the lungs become permanently weakened, perhaps ruptured in their air cells. Inexperienced persons find some difficulty in detecting broken wind from other chest affections, as chronic cough, occasional colds, &c. &c.

5790. *Criteria of broken wind.* The cough which accompanies broken wind is a short deep hollow grunting noise, and the short grunting expiration is peculiarly excited by turning a horse quickly round, striking him smartly with a stick at the same time, which often produces the deep sound without the cough; and which is so significant as never to be mistaken when once heard and attended to: but the principal peculiarity arises from the beating of the flanks, which operate rather by three efforts than by two as usual. In the first, the air is drawn in, in the usual manner, and the flanks fill up as in common; but in the next, the falling of the flanks is by no means natural, for it is not done by a gradual sinking of the sides, but it takes place at once, with a kind of jerk, as though the horse were sighing; and then a third effort takes place by a more slow drawing up of the muscles of the belly and flanks, to press out the remaining air. Broken wind destroys the fecundity of the mare, and hence argues permanent alteration of structure; it is also always incurable, but horses may be rendered very useful that have it, by feeding them very nutritiously, but with their food much condensed in bulk. Little hay should be allowed, and that little should be wetted, water in any other way should be given but sparingly, for which they are however very greedy: from which circumstance, as well as that they are peculiarly flatulent, we learn, that the vitiation of the lungs is either aggravated by the deranged state of the digestive organs; or, which is more probable, that the digestive powers become weakened from the state of the lungs.

5791. *Diseases of the belly.* Inflamed stomach seldom attacks the horse as an idiopathic affection, but it is not unrequent for the stomach to become inflamed by mineral poisons as well as rendered inert by vegetable ones.

5792. *Mineral poisons inflame the stomach* acutely, and produce excessive distress, and cold sweats; the animal lies down, rolls, gets up again, looks short round to his ribs, stamps with his fore feet, and his pulse beats quick and short. When arsenic or corrosive sublimate have occasioned the malady, a viscid mucus distils from the nose and mouth, and the breath is fetid. When copper in the form of vitriolic salts, or verdigris has been given, to the foregoing symptoms are usually added ineffectual attempts to vomit. Immediately the poisoning is discovered, pour down two ounces of *sulphuretted potash*, in a quart of water, or in the absence of that, an ounce of common potash in the same quantity of water: or when no better substitute is at hand, even strong soap suds are advisable. Mineral poisons have also another mode of acting, and are often received into the constitution, neither by design to do mischief, nor by mistake; but are purposely given as remedies. In this way, both mercury and arsenic are frequently given for worms, glanders, farcy, &c., in daily doses, which, when even of considerable magnitude, occasion for many days no inconvenience: all at once, however, the constitution becomes fully saturated with the poison, and although before diffused throughout the blood, it now appears to return and act on the stomach to the great surprise of the owner. In these cases the symptoms are not usually so violent as in the former instance, but they are equally fatal. A similar treatment with the one already prescribed is necessary, and as soon as the first symptoms are abated, give laxatives. In all these cases, large quantities of linseed tea should be horned down, the back should be raked, and clysters thrown up, blood should also be taken away plentifully. As a preventive to this latter mode of poisoning, whenever mineral agents are used, it is prudent every five or six days to stop a while, and then recommence, by which the constitution will part with the previous quantity.

5793. *Salivation is also another mode of poisoning*, and though not equally injurious to the stomach, it often proves distressing, and sometimes fatal. Whenever, therefore, mercurials are given, carefully watch the gums, and as soon as they look red, and the horse quids his hay, give him a mild purge instead of his mercurial.

5794. *Vegetable poisons also inflame the stomach*, but by no means in an equal degree with the mineral poisons; nor is it supposed that it is the inflammation they raise that proves destructive, but by an effect communicated through the stomach to the nervous system. *Digitalis purpurea* or foxglove, *Iarus baccata* or yew, *anemone crocata* or water dropwort, *cicuta virosa* or water hemlock, *phellandrium aquaticum* or water parsley, *conium maculatum* or common hemlock, are all poisonous in a high degree to horses, and may be taken accidentally by the animal as food, or given injudiciously as medicine. *Nicotiana* or tobacco, and the vegetable acid or vinegar, are also poisonous, and are sometimes productive of injurious consequences by over-doses, when intended as remedies. It is little known that a pint of strong vinegar has destroyed a horse. As we cannot remove the matters from the stomach, we must endeavor to neutralize their effects by acids and demulcents, as oil, butter, &c. Thus, when narcotics have been taken, a drachm of sulphuric acid or oil of vitriol may be given in a quart of ale; or six ounces of vinegar, with six of gin, and a quart of ale, may be tried.

5795. *Stomach staggers.* This peculiar complaint, which is even yet but little understood, appears dependent on a particular state of stomach, acting on particular foods; and not on what is taken in, acting on the stomach, as was supposed by Coleman, White, and others. From later communications of White, he also now appears to consider it as originating in "a peculiar state of stomach." Blaine appears always to have characterised it as "a specific inflammation of the stomach." It appears among horses of every description, and at grass as well as in the stable; and there is reason to think it epidemic, as it is prevalent in some seasons more than in others. It may, perhaps, be regarded now and then as endemic also; under which circumstance it appears confined to low wet situations, where long marshy grass is abundant, and where noxious aquatic plants mix themselves with the grasses. When it occurs at grass, the horse is found stupidly dull, or asleep with his head resting against something. This has occasioned the disease to be called the sleepy staggers: and it has often been confounded with the phrenitis or inflammation of the brain. (5760.) In the stable the horse drowses, and rests his head in the manger; he then wakes up and falls to eating, which he continues to do until the distention of the stomach becomes enormous; for the peculiarity of the complaint consists in the total stop that is put to digestion, and the uneasy feel of the distention consequent to such indigestion appears to deceive the horse, and by a morbid excitement to force him to take in more. In this way he continues eating until the distention prevents the return of the blood from the head, and the animal dies apoplectic, or his stomach bursts with over-distention. More fre-

quently, however, the stomach becomes flabby, inert, and paralytic, and after death presents marks of inflammation towards the pylorus.

5796. *The treatment.* When recovery has taken place, it has occurred only when the disease has been very mild, and has been assisted by stimulating the stomach into action by purgatives, at once active and invigorating, as an ounce of aloes dissolved in half a pint of gin. When a horse of extreme value is attacked, croton oil might be tried to the amount of ʒo or ʒ5 drops in two ounces of tincture of aloes. Warm water in small quantities, or mixed with common salt, should be frequently passed down. Remove every eatable, rake, clyster, and hand-rub; and if the determination to the head be extreme, bleed, otherwise avoid it.

5797. *Inflammation of the bowels, enteritis, or red colic,* is a very distinct disease from the gripes, gullion, or fret, with which it is, however, very apt to be confounded on the destruction of many horses. The peritoneal inflammation of the bowels, the one here treated on, is an affection of their outer covering.

5798. *The causes are various.* It is not unfrequently brought on by a sudden translation of cold after great heats, as swimming during hunting, or from the removal of a horse from grass at once into heated stables, clothing and hard food; neglected gripes, or long-continued costiveness, excessive riding, and the immediate drinking of cold water, have brought it on. It begins by restlessness, loss of appetite, some uneasiness; the mouth is hot and dry, the inner membranes of the mouth, nose, and eyelids, are often redder than natural. As the disease advances, the pain, before not violent, now increases so as to force the horse to lie down and rise again frequently; and when very violent, he kicks at his belly, or looks round at his sides, pawing his litter very frequently. The pulse is usually small, quick, or hard; sometimes it is more full and small, but always hard. Breathing is quickened, the extremities are alternately hot and cold, but continue longer cold than hot; and the animal is costive: sometimes pain may force away a few hardened balls of fæces, but the principal contents are retained. Blaine has given the distinguishing features between this disease and colic, under which head we have stated them.

5799. *The treatment* must be active and immediate, or a fatal termination may be expected. Begin by abstracting a considerable quantity of blood; from a large horse to the amount of seven or eight quarts; proceed to back-rake, throw up a large clyster of warm gruel. Give by the mouth, if the expense be not considered an object, a pint of castor oil, mixed by means of the yolk of two eggs, with half a pint of broth or gruel. If the expense be objected to, give olive oil instead, following it up in half an hour by a gruel drench, in which six ounces of Epsom salts have been dissolved. A sheep-skin, immediately as it is removed from the sheep, may be applied to the belly, which should first be well rubbed with the stronger liquid blister. (*Vet. Pharm.* 5893.) In four hours repeat the bleeding, if a considerable improvement have not taken place, and if the bowels be not unloaded, give more oil, and clyster frequently, having first back-raked. Avoid exercise; first hand-rub, and afterwards wrap up the extremities to the knees. As a clear passage for the dung is found, the symptoms mitigate, and the animal slowly recovers; but he must be fed at first very sparingly.

5800. *Inflammation of the inner surface of the intestines* is, in some measure, different from the former, which is rather an affection of their outer covering; whereas this is usually confined to their villous surface, and may be brought on by superpurgation from over-strong physic, or from mineral acids being taken in, particularly mercurials, which often exert more influence on the bowels than on the stomach. It differs from the former in the symptoms being generally accompanied with purging; neither is there usually so much pain or uneasiness present, nor such cold extremities; but where from the violence of the inflammation these symptoms are present, bleeding to the amount of three or four quarts is a proper preliminary, but can hardly be with propriety continued. The same stimulants to the outside of the belly should be used as in the last disease; but here, clothing is recommended as well as warmth in the stable, as also hand-rubbing to keep up the circulation in the extremities. Give astringent drink (*Vet. Pharm.* 5883. No. 1. or 2.) with a pint of boiled starch every three hours, and give the same by clyster with two quarts of pot liquor, or tripe liquor, free from salt.

5801. *Dysenteric inflammation of the horse's bowels* is happily not very common, but now and then appears, and is then called by farriers molten grease; they mistaking the morbid secretion from the intestines, for the fat of the body melted down and passing off thus. But dysentery is a peculiar inflammation of the mucous surface of the intestines, not contagious as in the human, nor epidemic, nor exhibiting a putrid tendency; but is peculiarly confined to a diseased increase in the mucous secretions, yet very different from simple diarrhœa, which is a mere increase in the peristaltic motion, by which the common aliments are quickly passed through the intestines, and ejected in a liquid form by an increase in their watery secretion. Whereas in the dysentery of the horse, the mucous of the intestines separates from them in large quantities; and comes away with the dung surrounding it; but when it does not pass in this way it appears in membranous films like sodden leather, or in stringy evacuations, like morsels of fat floating in water; sometimes there is a little bloody appearance. The usual symptoms of fever are always present, but not in a very high degree.

5802. *The causes* are cold, over-riding, and not unfrequently acrid substances within the intestines: change of food has occasioned it.

5803. *The treatment.* In the first stages bleed considerably, and give as the first internal remedy six ounces of castor oil, which will amend the fecal evacuations considerably; afterwards administer the following: powdered ipecacuanha, a drachm; powdered opium, a scruple; liquid arrow-root, eight ounces. Should this not check the evacuation, and should it continue as mucous as at first, again give castor oil, and then follow it up by either of the drinks directed for the cure of scouring or looseness. (*Vet. Pharm.* 5883.)

5804. *Diarrhœa or looseness.* This complaint originates in an increased peristaltic motion of the intestines with an increase of their watery secretion, and is distinguished from dysentery by the purging being complete from the first, and seldom occasioning much fever or disturbance in the general health, unless exceedingly violent. The stools are merely solutions of the aliment, and unmixed with membranous films as in dysentery or molten grease. It sometimes succeeds to over-strong physic; at others the food enters into new combinations, and forms a purge. Some horses have their bowels constitutionally weak, as lank-sided small carcassed ones, where the mechanical pressure hurries the contents forwards. Salt washes and sea water will purge horses violently sometimes. It is always proper to encourage warmth in the skin, and to change the food. The change should be generally from one more moist to one less so, as beans, &c. Barley will sometimes stop looseness; malt usually increases it. Buck-wheat is often a check to habitual diarrhœa. Efficacious astringents will be found in the *Vet. Pharm.* (5883.) Repeat either of these night and morning. Give but little water and that little warm.

5805. *Colic, flatulent, or spasmodic,* called also gripes, fret, or gullion, is an important, because a frequent, disease, and because it frequently destroys either quickly by its irritation, or by its degenerating into the red or inflammatory colic, when improperly treated or long continued. It is usually very sudden in its attack.

5806. *The causes of colic are not always apparent.* It is sometimes occasioned by intestinal stones, which accumulate to a great size, remaining for years in the cells of the colon, until some accidental displacement occasions an interruption to the peristaltic motion. Cold in its various forms is a parent of colic; but under the form of cold water given when a horse is hot, it is most common. In some horses it is so frequent as to become a constitutional appendage.

5807. *The distinguishing marks between colic and inflammation of the bowels* are gained, according to Blaine, by attending to the following circumstances. In gripes the horse has violent fits of pain, but they remit, and he has intervals of ease. The pain in red colic is more uniform and less violent. In gripes, the pulse is, in general, natural; in red colic it is quicker than natural, and commonly small.

The extremities are not usually cold in gripes; in red colic they usually are. In gripes, the horse attempts to roll on his back, which in red colic he seldom does. There are no marks of fever with gripes, as red eyelids, inflamed nostrils, &c.; but in red colic they are always present. When the complaint has continued some hours it is always proper to bleed to prevent its ending in inflammation: bleeding in the mouth is quite useless. Back-rake, and throw up clysters of warm water, one after another as fast as possible, which often overcomes the irritation. La Fosse recommends a curious remedy, but as it can always be obtained, and has the sanction of long experience, it may be tried. An onion is pounded and mixed up with some powdered savine: in default of which, use powdered ginger. This is to be introduced up the rectum as high as possible, and the horse is to be then moved briskly about. An onion put up the fundament whole has long been a domestic remedy. The following is recommended by Blaine: *spirit of vitriolic ather, an ounce; powdered opium, one drachm; oil of turpentine, three ounces; warm ale, a pint.* He also recommends the following more simple remedy as always at hand: *the expressed juice of two or three large onions, common gin, common oil, of each half a pint; mix and give.*

White recommends a pint of brandy, or of gin, with water, as an excellent carminative. Clark, who has expressly written on gripes, extols the virtues of a mixture thus made; which, if it have the qualities he attributes to it, and which there is no reason to doubt, no agriculturist, coach, or post master should be without it: *pimento berry, called also allspice, ground fine, half a pound; spirits of wine, and of water, of each a pint and a half; infuse these together, and keep for use.* Give a quarter of a pint every hour until full relief is obtained; hand rubbing, wiping, or fomenting the bowels with hot water at the time.

5808. *Inflammation of the intestines from wounds in the belly* frequently occurs; and these injuries may happen in leaping over hedges or pale gates, or may be inflicted by the horns of a cow. Sometimes the strong tendinous covering of the belly is ruptured, while the skin remains entire; the gut then protrudes and forces out the skin into a tumor. The first thing to be done is to put the gut back, taking care at the same time, otherwise extensive inflammation follows, to remove any dirt or other matter that may be sticking to it; for which purpose, should it be found necessary, it may be washed with warm water, but with nothing stronger. If the gut cannot be returned, from its being full of air, and the opening in the belly be too small to put it back again, such opening may be carefully enlarged to the necessary size. But if the animal can be thrown upon his back conveniently, a great deal may be done that cannot otherwise be accomplished; after the gut is returned the skin only should be stitched up, and a cushion of several folds of old linen and tow being placed in the wound, it should be kept in its situation by means of a wide bandage rolled round the body, and carefully secured. The animal should then be copiously bled, and have his bowels emptied by clysters. The only food he should be allowed is grass, or bran mash, and that only in moderate quantity. When the distention of the intestines wholly prevents their return, it would be prudent to puncture them with a very fine instrument, and thus to suffer the air to escape, which, although subjecting the horse to the risk of inflammation, is better than the certainty of death by having the intestines protruded.

5809. *Worms of horses* are found, as bots, in the stomach, but which as they attach themselves to the hard insensible part of that organ seldom do harm. Clark fancifully supposes they do good, and devises means for furnishing them when not in existence. The bot is the larva of the *æstrus equi*, a fly which deposits its eggs, it is supposed, on the grasses on which horses feed, and probably on parts of the horse himself, from whence they pass into the stomach by the food or by being licked off. Certain it is they get there, are hatched, and there remain hanging to the coats of it by two tentacula, receiving the juices of the masticated food as nutriment. After a considerable time they make their way out by the anus, drop on the ground, and are first transformed into chrysalids, and afterwards into parent flies. When bots fix themselves on the sensible portion of the stomach they may do harm; but no medicine that we know of will destroy them. The *teres* or large round worm sometimes occasions mischief, when it exists in great numbers, such as a starting colic, binding of the hide, irregular appetite, and clammy mouth. The best remedy is the *spigelia marylandica* or Indian pink, in daily doses of half an ounce. *Tania* are not common in the horse, now and then they exist, and are best combated by weekly doses of oil of turpentine, three ounces at a time, mixed by means of the yolk of an egg with half a pint of ale. *The ascaris* or thread worms are best removed by mercurial purgatives. The existence of worms may be known by the appearance of a yellow matter under the tail, and by the disposition the horse has to rub his fundament. Blaine recommends the following vermifuge: *powdered arsenic, eight grains, pewter or tin finely scraped, Venice turpentine, half an ounce,* make into a ball, and give every morning. He also recommends salt to be given daily with the food; which agrees with our own experience as one of the best vermifuges known. It is a fact acknowledged by the residents along the sea-coast, that horses troubled with worms will often voluntarily drink largely of sea water, and thus cure themselves.

5810. *The diseases of the liver are acute inflammation or hepatitis, and chronic inflammation or yellows.* *Hepatitis* is the acute inflammation of this organ, which, like the lungs, stomach, and intestines, may spontaneously take on the affection. The symptoms are not unlike those which attend red colic, but with less violence. If it be not however arrested, the termination will be equally fatal. About the third day, the whites of the eyes turn yellow and the mouth also. Bleeding, blistering, and purgatives form the methods of cure as practised in red colic.

5811. *Chronic inflammation or yellows.* The liver of horses is less complex than that of many other animals, and is therefore not very liable to disease; indeed some authors affirm that the horse is never affected with jaundice, but that the yellowness of skin is a mere stomach affection: this is, however, erroneous, and not only does the liver become hardened and thickened occasionally; but the bile becomes diseased, and is thrown out in that state by the blood over the body. If fever be present, bleed, but if the symptoms present no token of active inflammation, give each night, ten grains of calomel, and every ten days, work it off with a mild dose of physic. It is, however, necessary to remark, that it is not every yellowness of the skin that betokens either an acute or chronic inflammation of the liver. It is the property of every serious inflammation of any of the important organs of the chest and belly, to communicate a portion of the evil to the other organs immediately in conjunction with the liver: thus an affection of the stomach or intestines, of the inflammatory kind, very often occasions redness of the membranes of the nose, eyelids, &c. &c.

5812. *Diseases of the urinary organs.* Inflammation of the kidneys is an idiopathic affection, not one of frequent occurrence; but as brought on by injuries, such as over-riding, heavy loads, or violent diuretics, it is not unfrequent: when idiopathic, it may be the effect either of cold, heating food, or a translocation of some other inflammation, in which cases, it comes on suddenly, and assumes the same febrile appearances that other intestine inflammations produce; but there is not often great apparent pain, but a frequent inclination to stalt, the quantity made being so small as almost to amount to a stoppage of urine, which is less or more complete, as one or both kidneys are affected. What little urine is made is also at first very thick, and then bloody. When the disease is the effect of external injury, the urine is not so scanty, but is more bloody; and this symptom precedes the other. There is usually much pain and stiffness about the loins, and we learn from Blaine, that a swelling and a paralytic affection of the hind leg of the side of the affected kidney, sometimes is a feature in the complaint. To distinguish this inflammation from that of the neck or body of the bladder, with which it may be confounded, the same author recommends that the hand be passed up the rectum, when, if the affection belong to the kidneys, the bladder, whether full or empty, will not be hotter than usual; but the contrary occurs when any part of the bladder is the seat of the disease.

5813. *The treatment* must be active, and in most respects similar to what has been recommended for red colic, as regards bleeding, emptying the bowels, and endeavoring to lessen the arterial action by bleeding; but here we must carefully abstain from irritating the kidneys by diuretics internally, or blisters ex-

ternally. A newly stripped sheep skin placed over the loins, or active fomentations of hot water, are the only sources of counterirritation that are proper; neither should diluting liquors be pressed, on account of the distention they occasion, but no evil can arise from clustering.

5814. *Inflammation of the bladder.* When the body of the bladder becomes inflamed, there is frequent staling from the very first attack; but when the neck of the bladder is the seat of the evil, the squeezing out of a few drops will only take place when the bladder has become filled, which may be known by passing the hand up the rectum. The treatment will be alike in both cases, and is the same as recommended for the last affection. It must be evident, that warm, mild, and frequent clustering, must here be peculiarly advisable.

5815. *Strangury or suppression of urine; incontinence of urine; bloody urine.* Strangury may arise from an injury done to the kidneys, or to the bladder, by strains, or by the absorption of irritating matters. In these cases, bleed if there be fever, and if not, merely give the horse absolute rest; mash him, give gruel, and warm his water for drink. *Bloody urine* should be treated in the same way; some horses have such a natural or acquired weakness of kidneys, as to stale blood with their urine on every occasion of over-exertion: the means frequently used for relief are such as aggravate the complaint, and indeed are often the occasion of it, which are diuretics. Strong diuretics injure horses more than strong physic, and benefit them less than any other of the popular means made use of. In retentions of urine, but particularly in the case of bloody urine, they are absolutely improper.

5816. *Diabetes, profuse staling, or pissing evil.* This disease is more frequently forced on the horse, by long continued diuretics, or from a similar effect brought on by kiln-dried oats, mow-burnt hay, and some green vegetables, than acquired from constitutional indisposition. The horse first stales often and profusely, he then becomes weak and faint, and sweats on any exertion. If it be at all constitutional, his hide is bound from the beginning, and his urine will have a sweet taste; but if his appetite were good, and his coat sleek, bright, and elastic when the urine was first observed to be immoderate, the evil arises from some fault in the feeding, clothing, exercise, or other management of the horse. Examine into these matters, particularly into the food, and next the water. Enquire whether diuretics have been given, under an erroneous supposition of increasing the condition, and alter what may be amiss. If this do not remove the complaint, try the following, after Blaine's directions: *liver of sulphur two drachms, uva ursi four drachms, oak bark one ounce, catechu half an ounce, alum half a drachm*: give as a daily drink in a pint of water.

5817. *Stone and gravel.* Calculous concretions are not uncommon in the large intestines of horses, where they grow sometimes to an enormous size, lodged in one of the cells usually, and where they occasion but little inconvenience, except a displacement occurs, when serious evils, as colic, inflammation, or total stoppage, follow. In the bladder, stone is very seldom found; and there is reason to believe, that though gravel is a common term in the farrier's list, that it seldom if ever occurs; injuries of the kidneys and bladder being usually mistaken for it.

#### SUBJECT. 6. Diseases of the Skin.

5818. *Mange is a contagious disease* not uncommon among low bred and badly kept horses, but which is seldom generated in those properly managed. When it is the effect of impoverished blood, a different course of feeding must be substituted, not heating, but cooling though generous; as carrots, speared corn, malt mashes, stable soiling, &c. When it arises in full fed horses, bleed twice, lower the feeding, substituting for corn, soilings, carrots, or bran mashes. Give a nightly alterative (*Vet. Pharm.* 5831. No. 1. or 2.), and dress with either of the mange dressings. (*Vet. Pharm.* 5923.) After a cure has been effected, carefully clean all the apartments with soap and water.

5819. *Surfeit will now and then degenerate into mange*, but more generally it is brought on by a fulness of habit acted on by sudden transitions from cold to heat, or heat to cold; it is likewise not unfrequently the consequence of over-fatigue. If it show a disposition to spread, and the skin become scaly and scurfy, treat as under mange; otherwise treat as directed under want of condition. (5756.)

5820. *Warbles* are of the nature of surfeits in many instances, in others they are brought on by the pressure of the saddle, which either suppurate and burst, or become indolent and remain under the name of *sifstas*. In the early state, bathe them with chamberlye or vinegar: if they proceed to suppuration refrain, and when they neither go back or come forward, put on a pitch plaster, and if this do not promote suppuration, let the sifstaf be dissected out.

5821. *Warts are common to old horses*, and had better be put up with, unless they be situated in some inconvenient or very conspicuous part. In this case tie a thread tightly around the root, and the wart will drop off, or it may be cut off. Blaine recommends the following, when warts are too numerous to be so removed: *crude sal ammoniac two drachms, powdered savin one ounce, lard an ounce and a half*.

5822. *Hide bound is a state of the skin*, where the interstitial matter between that and the fleshy pannicle is not in a state to allow of its pliancy and elasticity. The binding down of the hide thus closely, acts on the hair, which it protrudes in a contrary direction to its naturally inclined position; and thus a staring coat usually accompanies hide binding. In considering the subject of condition (5756.), we have seen that it is not a disease of itself, but is in every instance a symptom only.

#### SUBJECT. 7. Glanders and Farcy.

5823. *The glanders is the opprobrium medicorum*, for hitherto no attempts have succeeded in the cure of more than a few cases. By some peculiar anomaly in the constitution of the horse, although conclusive proofs are not wanting that this and farcy are modifications of one disease, and can each generate the other; yet the one is incurable, while the other is cured every day. When glanders has been cured, the time and labor necessary to accomplish the end has swallowed up the value of the horse; and has also in many supposed instances of cure, left the animal liable to future attacks which have occurred. The experiments on glanders, pursued at the veterinary college and by White of Exeter, have thrown great light on the disease itself, its causes, connections, and consequences; but have done little more. From these we are led to conclude that glanders will produce farcy, and that farcy can produce glanders. That glanders is highly infectious, and that such infection may be received by the stomach, or by the skin when it is at all abraded or sore; and it is also probable that it is received by the noses of horses being rubbed against each other. White's experiments go to prove that the air of a glandered stable is not infectious; but this matter is by no means certain, and should not be depended on without a greater body of evidence.

5824. *The marks of glanders* are a discharge of purulent matter from ulcers situated in one or both nostrils, more often from the left than the right. This discharge soon becomes glairy, thick, and white-egg-like: it afterwards shows bloody streaks, and is foetid. The glands of the jaw of the affected side, called the kernels, swell from an absorption of the virus or poison, and as they exist or do not exist, or as they adhere to the bone or are detached from it, so some prognosis is vainly attempted by farriers, with regard to the disease; for in some few cases these glands are not at all affected, and in a great many they are not bound down by the affection to the jaw. As there are many diseases which excite a secretion of matter from the nose, and which is kept up a considerable time; so it is not always easy to detect glanders in its early stages. Strangles and violent colds keep up a discharge from the nostrils for weeks sometimes. In such cases a criterion may be drawn from the existence of ulceration within the nose, whenever the disease has become confirmed. These glanderous chancre are to be seen on opening the nostril a little way up the cavity, sometimes immediately opposed to the opening of the nostril; but a solitary chancre should not determine the judgment. The health often continues good, and sometimes the condition also, until hectic takes place from absorption, and the lungs participate, when death soon closes the scene.



5825. The treatment of glanders, it has already been stated, is so uncertain that it is hardly worth the attempt; however, when the extreme value of the horse or the love of experiment leads to it, it may be regarded as fixed by experience, that nothing but a long course of internal remedies, drawn from the mineral acids, can effect it. These have all been tried in their endless variety: White recommends the mildest preparations of mercury, as *athlops mineral*; under the conviction that the more acrid preparations disturb the powers of the constitution so much, as to destroy as effectually as the disease. At the veterinary college the *sulphate of copper* (blue vitriol) has been long in use. Others have used the *sulphates of iron and zinc*. Clark recommends the daily administration of a drink or ball, composed of the following ingredients: *sulphate of zinc 15 grains, powdered cantharides 7 grains, powdered allspice 15 grains*; of which he gives one or two extraordinary proofs of utility.

5826. The farcy is a disease more easily cured than the glanders, of which our daily experience convinces us; farcy, or farcin, attacks under distinct forms, one of which affects the lymphatics of the skin, and is called the *bud or button farcy*: the other is principally confined to the hind legs, which it affects by large indurations, attended with heat and tenderness. A mere dropsical accumulation of water in the legs sometimes receives the name of *water farcy*; but this has no connection whatever with the true disease in question; farcy is very contagious, and is gained from either the matter of farcy or from that of glanders.

5827. Treatment of farcy. The distended lymphatics or buds may often be traced to one sore, which was the originally inoculated part, and in these cases the destruction of this sore, and that of all the farcied buds, will frequently at once cure the disease, which is here purely local. But when the disease has proceeded farther, the virus must be destroyed through the medium of the stomach; although even in these cases, the cure is rendered more speedy and certain, destroying all the diseased buds, by caustic or by cautery. Perhaps no mode is better than the dividing them with a sharp firing iron; or if deeper seated, by opening each with a lancet, and touching the inner surface with *lapis infernalis*. The various mineral acids may any of them be tried as internal remedies with confidence; never losing sight of the necessity of watching their effects narrowly, and as soon as any derangement of the health appears, to desist from their use; *oxymuriate of quicksilver* (corrosive sublimate) may be given in daily doses of fifteen grains; *oxide of arsenic* may also be given in similar doses. The *subacetate of copper* (verdigris) may also be tried, often with great advantage, in doses of a drachm daily. Blaine joins these preparations, and strongly recommends the following: *oxymuriate of quicksilver, oxide of arsenic, subacetate of copper, of each eight grains; sulphate of copper one scruple*; make into a ball and give every morning, carefully watching the effects, and if it be found to occasion distress, divide, and give half, night and morning. The same author professes to have received great benefit from the use of the following: *the expressed juice of divers or goose-grass, a strong decoction of hempseeds, and of sassafras, of each six ounces*, to be given after the ball. It remains to say, that whatever treatment is pursued will be rendered doubly efficacious if green meat be procured, and the horse be fed wholly on it; provided the bowels will bear such food; but if the medicines gripe, by being joined with green food, add to the diet bean-meal. When green meat cannot be procured, carrots usually can; and when they cannot, still potatoes may be boiled, or the corn may be speared or malted. As a proof of the beneficial effects of green meat, a horse, so bad with farcy as to be entirely despaired of, was drawn into a field of tares, and nothing more was done to him, nor further notice taken of him, although so ill as to be unable to rise from the ground when drawn there. By the time he had eaten all the tares within his reach, he was enabled to struggle to more; finally he rose to extend his search, and perfectly recovered.

#### SUBSECT. 8. Diseases of the Extremities.

5828. *Shoulder strains* are very rare, most of the lamenesses attributed to the shoulder belong to other parts, and particularly to the feet. Out of one hundred and twenty cases of lameness before, Blaine found that three only arose from ligamentary or muscular extension of the shoulder, or rather of the adductor and sustaining muscles: when shoulder strain does happen, it is commonly the consequence of some slip, by which the arm is forced violently outwards. It is less to be wondered at than at first seems probable, that farriers mistake foot lameness for shoulder strains, when we reflect that a contracted foot occasions inaction, and favoring of the limb; which thus wastes the muscles of the shoulder. Seeing that one shoulder is smaller than the other, the evil is attributed to that, and it is pegged, blistered, swam, and fired, to the torture of the animal and the increase of the foot's contraction by the confinement. In real shoulder strains, the toe is dragged along the ground while in motion; at rest it is planted forward, but resting on the point of the toe. When the lameness is in the foot, the horse points his foot forward also, but he does so with the whole limb unbent, and the foot flat. These differences are highly necessary to attend to, as well as the peculiar difficulty there is in moving down hill, which he does with reluctance, and by swinging his leg round to avoid flexing it. This lameness may be farther brought to the test by lifting up the fore leg considerably, which, if the evil be in the shoulder, will give evident pain. The muscles between the fore legs are likewise tumefied and tender in these cases.

5829. The treatment consists, when it is recent, in bleeding in the plate vein, rowelling in the chest, and fomenting with hot water two or three times a day. When the heat and tenderness have subsided, first bathe daily with the astringent wash for strains (*Vet. Pharm.* 5886. No. 1.) for a week; and afterwards, if necessary, proceed to blister in the usual manner.

5830. *Strain in the whirl bone* (5655.). This important joint is sometimes strained, or its ligaments and muscles unnaturally extended, from a greater force being applied to them than their structure is able to bear, or their powers to resist: a lesion takes place of some of their fibrille, or in lesser injuries their elasticity is injured by being put on the stretch beyond their power of returning. In all such cases, the parts react, and inflammation follows; by which heat, tenderness, and swelling ensue.

5831. *Treatment.* The first indication is the same in this as in all ligamentary strains, which is to moderate the inflammation by fomentations, &c. &c., and when that has subsided, to endeavor by astringents and bracers to restore the tone of the parts: after which, if any swelling remains, from the extravasated blood becoming organised, to promote its absorption by mercurial frictions, and blistering. This applies to all strains, and will direct the treatment therefore of that of strain in the articulation of the thigh with the body also.

5832. *Strain in the stifle*, is treated in the same manner.

5833. *Strain or clap in the back sinews.* This is generally an injury done to the sheaths of the tendons, or of the ligaments which bind them down. In very aggravated cases, it sometimes occurs that even the tendons themselves are extended beyond their capacity. The heat, swelling, and tenderness, are first to be combated by fomentations, and if these be extreme, bleed also, and give a dose of physic. Next proceed to poultice with saturnine applications, until the heat and swelling are reduced: then use tonics,

*astrigent wash*, (*Vet. Pharm.* 5886. No. 1. or 2.) : bandage and exercise very carefully. If swelling remain after heat, pain, and lameness are past; or when lameness only remains, after all heat is gone, proceed to blister mildly twice. In all cases of ligamentary extension when the heat has subsided, the part may be considered as in a state of atony; and bandages judiciously applied are then proper, particularly during the day.

5834. *Rupture of the tendons and ligaments of the leg.* It is very seldom that the tendons themselves are ruptured, but the suspensory ligaments are more often so, and the evil is called breaking down. It is usually very sudden, and the fetlock is brought almost to the ground. A perfect cure is seldom obtained; but the inflammation should be moderated by the means already described, and the heels should be raised. A laced stocking or firm bandage, when the inflammation has subsided, is necessary; and firing is often prudent as a permanent bandage.

5835. *Strains of the ligaments of the fetlock and coffin joints* often occur, and may always be distinguished by the heat, tenderness, and swelling. Treat as already described. In all strains of the leg, attended with inflammation, a goulard poultice is a convenient and useful application. The goulard water should be mixed with bran, and a worsted stocking being drawn over the foot, and up the leg, it is first tied around the foot; the poultice is then put in, and the stocking fastened around the leg above the injury. (5867.)

5836. *Mallenders and scellenders* are scurvy, scabby eruptions, affecting the back of the knee, and ply of the hock; common only in coarse, low-bred, and in cart-horses. Wash with soft soap every day, after which anoint with an unguent formed of equal parts of mercurial ointment, tar, and Turner's cerate.

5837. *Broken knees.* The usual cases of broken knees are referrible to wounds in general; and the treatment of them in no wise differs therefrom, with this caution, that here it is more immediately necessary, both for appearance and safety, that if any flap of skin hang apart, to cut it off, or the wound will heal with rugged edges. But when the joint of the knee is broken into by the violence of the injury, it becomes of a very different nature; and is known first by the extreme lameness and swelling that occur; and next, by the escape of a slippery mucus not unlike the white of an egg. If this continue to escape, violent inflammation follows, and either the horse or the joint are lost by it. Farriers are apt to attempt to stop the flow of the *joint oil*, as it is called, by oil of vitriol, or other escharotics, which treatment is usually followed by the most disastrous consequences. It is, however, necessary to stop the immediate flow, by other means; the best of which is by a fine budding-iron heated. Should the laceration be considerable, this cannot be done; but the treatment must then consist of saturnine poultices, bleeding, low diet, and the other antifebrile remedies, until the swelling has subsided, when apply the astringent paste recommended by Clark, made of pipe-clay and alum, every day; but by no means introduce any escharotics. On the subject of broken knees, a prejudice prevails, that a horse that has once broken his knees, is more liable to fall again than a horse that has not before fallen down; but unless the knees be injured so as to become stiff by such an accident, the supposition is wholly erroneous. Horses fall as often by treading on sharp stones when they have corns, as they do by stumbling; and as corns sometimes come on rapidly by pressure, so such a horse becomes afterwards liable to trip, and this gives rise to the opinion formed, that when once he has been down he will ever after be liable to it.

5838. *Splints and bone spavins.* The former are usually situated on the inner side of the canon or shank bone; and as they are situated, so they are more or less injurious. When buried, as it were, within the tendons or back sinews, they are very apt to lame the horse seriously; but when situated on the plain bone, unless they be very large, they seldom do much injury. If a splint be early attended to, it is seldom difficult to remove. Blaine recommends the swelling to be rubbed night and morning for five or six days, with a drachm of mercurial ointment, rubbing it well in; after which to apply a blister, and at the end of a fortnight or three weeks to apply another. In very bad cases, he recommends firing in the *lozenge form*.

5839. *Bone spavin* is an exostosis of the hock bones, the treatment of which in no wise differs from that of splint; except that as a spavin in general is more injurious than a splint, so it is more necessary to commence the treatment early, and to continue it energetically. It also unfortunately happens, that from the complexity of structure on the hock, spavin is not so easily removed as splint, and more usually requires the application of firing.

5840. *Ring bone* is of the same nature, being an exostosis or bony circle formed around the coronet, the treatment of which is the same with splint and spavin.

5841. *Blood spavin, bog spavin, and thoroughpin,* are all of them originally of the nature of windgalls, and are nothing more than enlargements of the bursal capsules described in the anatomy, as surrounding tendons, ligaments, and bones, to furnish them with a lubricating medium. By over-exertion or hard work these bursal bags become extended, and their contents increased, and distended into puffy swellings in the hock, called, when on the pty, bog spavin. The pressure of this sometimes occasions a varicose state of the superficial vein, which passes directly over it on the inner side of the hock, and which enlargement then receives the name of *blood spavin*. When the bursal enlargement extends through the hock, it is called *thoroughpin*. When it is situated below, in the bursæ of the flexor tendons, near the fetlock joint, it receives the name of *windgall*.

5842. *The treatment* of all these cases must be similar in principle, and consists in lessening the distended sac; not as was formerly practised to the destruction of the horse often, by letting out the contents of these windgalls; but by strengthening the sides of the tumors by stimulants or by pressure. The more active stimulants are the liquid blister (*Vet. Pharm.* 5893.), milder ones are found in the astringent wash. (*Vet. Pharm.* 5886. No. 1.) Bandages assist greatly, when well applied to the part, and in desperate cases firing has been resorted to, which is nothing more than a more violent stimulant, and a more permanent bandage.

5843. *Capulet* is a bursal enlargement of the point of the hock, and is to be treated by friction, astringents, and bandage.

5844. *Curb* is an inflammation of the ligaments at the back of the hock, and is usually removed by astringents. (*Vet. Pharm.* 5886.) When it does not give way to these, the sweating liquid blister may be applied. (*Vet. Pharm.* 5894.)

5845. *Cracks and grease* may be considered as modifications of one and the same affection, and are commonly brought on by some neglect in all horses; but when they occur in any but the thick-heeled low-bred animals, they are invariably so. Over-feeding or under-feeding, but much more frequently the former, will bring it on. A very frequent cause of it is the practice of washing the legs of horses, and suffering them to dry of themselves. In every case, without exception, washing the legs should be avoided, unless they be rubbed perfectly dry afterwards. When horses have long hairs about their heels, and are washed and then left wet, the evil must be doubled; as the evaporation going on, cools and chills the heels, and thus produces a species of chilblain; and we well know how difficult these are to heal when broken. Cracks in the heels very often occur in horses removed too suddenly into full keep from previous straw or grass, or from these to a hot stable; which, by the heat and moisture of the litter, occasions a determination of blood and humors to the legs, and they break out into cracks or scabs, from which issue a bloody ichor, or a more thick matter. Between the sores the hair stares and gets pen-feathered, and the horse finds difficulty and pain in moving.

5846. *The treatment* must depend on the state in which the animal is at the present. If there be reason to suspect the horse to be full and foul, bleed, lower his food, soil him in the stable; or mash and give a mild dose of physic. But when some mismanagement is the sole cause, remove that, and if the case be a severe one, by means of an old stocking drawn over the foot, bury the whole heel in a poultice, made of scraped carrots or turnips; which will subdue the irritation, and bring the parts into a state to bear the application of the astringent paste (*Vet. Pharm.* 5888. No. 2.), or if more convenient, of the astringent wash.

(*Vet. Pharm.* 5886, No. 1, or 2.) Moderate exercise should be continued, and the heels carefully cleaned from dirt by soft soap and water on each return therefrom; after which, always again apply the astringent.

5847. *Grease* is nothing more than an aggravated state of the same affection, and is more common to the hind than to the fore legs. Coarse fleshy-legged horses are peculiarly prone to the affection, from the great accumulation that takes place in their legs; and from the difficulty that the capillaries find in carrying the increased quantity of lymph upwards. In these, long stable confinement should be avoided, and when that is impossible, it should be counteracted by exercise frequently and judiciously administered. Many cart horses never go out but to work: they often work three days incessantly, or nearly so; and they perhaps rest two days entirely. Can it be wondered at, that the change occasions swelling, acting on the weakness and exhaustion of previous fatigue? and could not this be avoided by turning out for an hour; or walking for half an hour night and morning? Stable soiling should be used; bleeding and physicking also in very bad cases; and when the inflammation and irritation or soreness are great, the poultices recommended for cracks, should be applied until these circumstances are removed; when commence the use of some of the astringents recommended. (*Vet. Pharm.* 5886.) White has stated two remarkable cases of grease cured by the application of corrosive sublimate, in the form of a wash, as of two drachms of sublimate to ten ounces of water; increasing it to three drachms, if the pain occasioned by the first be not too considerable. Blaine says that the clivers or goose-grass has been known to be of great service in bad cases of grease: half a pint of the expressed juice to be given daily as a drink; and a poultice of the herb to be applied to the heels. In some cases of long standing when the running has ceased, a thickened state of the limb remains, which is best removed by firing, and which likewise is a preventive to a return.

### SUBSECT. 9. Diseases of the Feet.

5848. *Founder of the feet* is of two kinds, an acute and a chronic. *Acute founder* is a disease that, until lately, was less understood than almost any other. After a very severe day's work, or when very much heated, if a horse get a sudden chill by standing in snow or cold water, it is not uncommon for him to be seized with universal stiffness and every symptom of great fever. Such a horse is said to be *body founded*. By degrees, however, it is observed that the animal has an extreme disinclination to remain on his feet; from whence it will appear that the whole of them are affected. When the horse draws his hind feet under him, his fore only are affected; and when he draws his fore feet under him, the hinder feet are the seat of the complaint; but which is seldom the case. On feeling the feet they will be found intensely hot, and the pastern arteries will beat with great violence. After a few days, unless the disease abate, a separation of the hoofs from the coronet takes place, and at last they fall entirely off.

5849. *The treatment.* At the commencement of the disease bleed largely, as well by the neck as from the toe of each affected foot, by paring, until the blood flows freely. After which immerse each foot in a goulard poultice, (5867.), give the fever powder or drink (*Vet. Pharm.* 5909. and 5910.), litter up to the belly; and if amendment do not take place, renew the bleedings, and blister round the pasterns.

5850. *Chronic founder, contraction or fever in the feet.* The artificial life that horses lead, subjects them to many diseases; one of the principal of which is that of contracted feet. Blaine considers a neglect of sufficient paring of hoof, the application of artificial heat from hot stables, and hotter litter, the deprivation of natural moisture, constitutional liability, and the existence of thrushes, as among the principal causes of this evil. It is more common to blood horses than to others; and he observes, that dark chestnuts are of all others most prone to it. The appearances of a contracted foot, as contrasted with a healthy one, we have already displayed. (5751.) It is there shewn that the contracted hoof becomes longer, higher, and narrower: the heels (*fig. 621 a a*) particularly are drawn in, and seem to screw the frog between them, which becomes wasted and thrushy from this pressure. The hinder hoofs are seldom affected.

5851. *The treatment of contraction in the feet.* It is better to prevent, than to be under the necessity of attempting to cure the evil. Prevention may be practised by avoiding the acting causes. As soon as all suspected to be likely to occur, keep the hoofs pared low; never suffer the horse to stand on litter, nor allow the stable to be too hot, feed moderately, and never allow the horse to go without daily exercise; whatever increases the general fulness of habit, flies to the feet. Above all, keep the feet moist by means of wet cloths tied loosely around the coronet, falling over the whole hoof, but not extending beyond the edge. Then moisten repeatedly, and stop the feet (5918.) every night. When contraction has already taken place, many plans have been recommended; as jointed shoes by Coleman, Clark, and others; but it is not found that mechanical expansion in this way produces permanent benefit. The most effectual mode is to obviate all previous causes of contraction; and then to thin the hoofs around the heels from each quarter so thin as to be able to produce an impression by means of the thumb: in fact, to remove so much of the horn as is consistent with safety, from the coronet downwards. It is also prudent to put in a score or two from above downwards, drawn a quarter of an inch deep on each side towards the front of the hoof; but whether this be done or not, the front of the hoof should be rasped thin about an inch in width; by which means a hinge is formed, which operates most advantageously in opening the heels. After this is done, tips should be put on, and the horse should be turned out to grass, where he should remain three months, by which time the new formed heels will have reached the ground, and will bear a shoe. This process is fully described by Blaine in his *Veterinary Outlines*, where a plate completely elucidates the operation, and to which we would recommend the reader.

5852. *The pumiced foot* is a very common consequence of acute founder, in which the elasticity of the lamina becoming destroyed, the support of the coffin bone is removed, and it rests wholly on the sole, which it gradually sinks from a concave to a convex surface, drawing with it the front of the hoof inwards. In weak, broad, heavy feet, this evil comes on sometimes without founder; the treatment can be only palliative, a wide webbed shoe exactly fitted to the foot, without at all pressing on it, prevents the lameness consequent to the disease. A shoe exactly the contrary to this has been tried in some cases with benefit, the form of which has been one with a web so narrow as only to cover the crust, but so thick as to remove the feet from accidental pressure. In other cases, no shoe answers so well as a strong bar shoe. (5932.)

5853. *Corns* are most troublesome ailments, to which horses are very liable, and which injure and ruin thousands; they are wholly accidental; no horse having any peculiar tendency to them, but being always brought on them by some improper pressure, usually of the shoe, or from something getting in between the shoe and the horny heel. A shoe too long worn is a very common cause, and a still more frequent one is the clubbing the heels of the shoe; neither is it necessary to the production of corns, that the shoe itself should press on the sole; but they are equally produced when the outer horn of the heels or of the bars, is the immediate offending part, rendered so by too luxuriant growth, by unequal wear, or by secondary pressure from the shoe, or by gravel working in. (*fig. 621.*) It is the fleshy sole itself that is bruised, from which, a speck of extravasated blood follows; and if not immediately relieved, it gathers, or the part becomes habitually defective, and instead of forming healthy horn, it always afterwards forms a spongy substance of extreme sensibility, and thus always is liable to produce pain and lameness when exposed to pressure.

5854. *The treatment of corns* is seldom difficult or unsuccessful at their first appearance, but afterwards, it can be only palliative. Blaine directs that by means of a fine drawing knife, every portion of diseased horn should be pared away, and the extravasation underneath likewise. Having done this, he advises to introduce some *butter of antimony* into the opening, to place over this some tow, which should be kept in its place by means of a splint. If any contraction of the heels (*fig. 621 a a*) be present, it will materially assist

the cure to lower them, and to thin the hoof a little around the quarters, and afterwards to put on a shoe without heels opposed to the corn, or a shoe chambered opposite the weak part; or a bar shoe may be applied, so framed as completely to leave the heel untouched. Introduce the butter of antimony once or twice more, with the interval of two days between, and then turn the horse out to grass: in about six weeks' time the foot will be sound. The treatment of corns, when of long standing, does not materially differ; for although they are never wholly eradicated, they may be rendered but little troublesome. The diseased part must be carefully pared out at each shoeing, and such a shoe put on as will completely free the heel from pressure.

5855. *Running thrush is always a dangerous disease*, and few errors in horse management are more glaring than the common one of supposing they are necessary to carry off humors. If less food, more exercise, cool stables, and dry standings, were substituted to correct the fullness, instead of thrushes, which invariably contract the feet whenever they continue any length of time, it would save many valuable horses. To the cure, begin by clearing out all the fissures of the frog (*fig. 621 a a*) from loose ragged horn, and then introduce to the bottom of the sinuses, by means of a thin piece of wood, some of the *thrush paste* (*Vet. Pharm.* 5885.), smeared on tow, which will enable it to be held within the cleft, especially if it be guarded by splints of wood passed under the shoe; renew the dressing daily: turning out to grass may be practised to great advantage for thrushes by this mode of dressing.

5856. *Sandcracks are fissures in the hoofs*, commonly of those before, and usually towards the inner, but now and then towards the outer quarter also, from above downwards: from the crack, a little oozing of blood or moisture is seen; and the sensible parts underneath getting between the edges of horn, being pressed on, lame the horse. White recommends to fire the fissure crossways, so as to destroy the connection between the divided and the undivided parts of the hoof.

5857. *Pricks or punctures in the feet* are often very serious evils, either when received by nails in shoeing, or by one picked up on the road, &c. The danger arises from the inflammation, which is always great from any injury done to the sensible and vascular parts within the foot. This inflammation quickly proceeds to suppuration; and the matter is apt to make its way upwards, unless it find a ready vent below. When it does not break out at the coronet, it will often penetrate under the sole, and finally disease the bones, ligaments, or cartilages, and produce quittor. It is very seldom that a horse is pricked in shoeing, but that the smith is aware of it by the peculiarity of the feel on the hammer, and by the finching of the animal. At such times were he to immediately withdraw the nail a little, enlarge the opening, and introduce some spirit within the puncture, nothing would occur; but on the contrary, he sends the horse home to avoid trouble, who, the next or following day, is found lame, and with his foot hot. If the nail be only driven too near the sensible laminae, it will only require to be removed to free the horse from his evil; but if it have been driven through, and have wounded them, then suppuration ensues, and on examining the foot by the pincers when the shoe is removed, he will find at the pressure on the diseased part. It is probable, on the removal of the shoe, that matter will at once flow out at the immediate nail hole; if not, the drawing knife will soon detect the injury. If the heat be great, and instead of matter, bloody dark ichor flows out, wrap the foot up in a poultice; but if healthy matter flows out, this will not be necessary: sometimes it is requisite to detach all the horn that is underrun by the matter; but when the injury has not proceeded to this extent, apply over the part a pledget of tow steeped in friar's balsam; tack on the shoe lightly, and retain the dressing by means of *splints*, which are thin pieces of wood (the withy which binds birch brooms, is convenient for the purpose,) passed under the shoe; repeat the dressing daily, and avoid moisture, which would encourage quittor. A nail picked up on the road, and which passes through the sole, below or through the frog, is to be treated in the same manner, and also when the matter breaks out at the coronet; but when a nail is picked up, and penetrates the coffin joint, which is known by the synovia or joint oil appearing; such opening should be immediately stopped by paring towards the wounded joint, and then applying a heated budding-iron, not to the capsular ligament itself, but to the skin immediately near it; if this be inconvenient, put a pledget dipped in a little butter of antimony, just within the opening, but do not press it into the cavity of the joint: if this be insufficient to stop the flow, but more particularly if the original wound penetrated to the bone, it is probable that the bone itself will become in some measure diseased, which is known by the rough grating felt at the point of the probe when passed. In this case, enlarge the opening so as to be able to scrape the diseased bone away. *Bruises of the sole*, from whatever cause, will all fall under some of these points of view, according as the case may be.

5858. *Quittor and canker are the consequences of these injuries* when neglected, or originally extensive. In these cases either the bones, ligaments, or cartilages, or all, become diseased; and a cure can only be obtained by removing the diseased parts by the knife or by caustic.

5859. *Treads, over-reach, &c.* A wound on the coronet is not uncommon from one foot being placed on the other; or the hinder foot may strike it, &c. First wipe away the dirt, and remove any loose edges that cannot unite; avoid washing, unless stones and dirt are suspected to be within, and bind up, having first placed over the wound a pledget of lint or tow moistened with balsamic tincture, or tincture of myrrh, or of aloe, &c. *Over-reaching, or over-stepping*, is often an injury done to the fetlock joint before, by the hinder foot, or to the back sinew higher up. Sometimes it is simply a violent bruise, at others the laceration is extensive, in which case treat as a tread; and when no laceration has taken place treat as a bruise or strain.

5860. *Cutting* is a defect to which some horses are liable from their form, as when they turn their toes out, or have bent legs. Others cut only when they are lean, which brings their legs nearer together. Weak horses cut because they cross their legs when fatigued, and young unfurnished horses cut at youthful periods, and grow out of it afterwards. The part in which a foot interferes with the opposed limb is very different. When it strikes the shank high up it is called *speedy cut*, and is best remedied by wearing knee boots or rollers. When it is at the fetlock the cutting is at the side, or rather backward, according to circumstances. Some horses cut by the edge of the shoe, others by the hoof at the quarters; and some by the point of the heels. It is to be remarked, that it is better to put up with the evil of cutting, than to do as is too frequently done, which is, to pare away the hoof until it excites contraction. The shoe may be feather edged, or it may be set a little within the cutting quarter; but by no means alter the size or the form of the hoofs themselves, and particularly avoid taking liberties of this kind with the fore feet. Boots, or rollers, are but little trouble to put on, and when not buckled too tight never injure: whereas to allow a horse to continue to cut produces a callus, and often throws the animal down.

## SECT. VI. *Veterinary Operations.*

5861. The general practices to be here enumerated are chiefly the treatment of wounds, the application of fomentations, setons, blisters, clysters, and physicking; and the operations of castrating, nicking, bleeding, &c.

### SUBSECT. 1. *Treatment of Wounds.*

5862. *A wound* must be treated in some measure according to the part of the horse's body in which it happens; but there are some principles to be observed alike in all horse surgery. There are likewise a few, which, as they differ from the principles of human surgery, should be first noticed, and which should guide the practice of those who might be misled by analogy. The wounds of horses, however carefully brought together and confined in their situation, as well as shut out from the sti-

mulus of the external air, are seldom disposed to unite at once, or, as it is called in surgical language, by the *first intention*. It is always, therefore, necessary to expect the suppurative process: but as the adhesive inflammation does now and then occur, we should never wash with water or other liquids a mere laceration, if no foreign matter, as dirt, &c., be suspected to be lodged within it, still less should we stuff it with candle or tents of any kind. On the contrary, it should be carefully and smoothly brought together, and simply bound up in its own blood; and if it do not wholly unite at once, and by the *first intention*, perhaps some portion of it may; and, at all events, its future progress will be more natural, and the disfigurement less than when stuffed with tents, tow, &c., or irritated with heating oils or spirits. When an extensively lacerated wound takes place, it is common, and it is often necessary to insert sutures, or stitches, into the lips of the wound: and here we have to notice another considerable variation from the principles of human inflammation, which is, that these stitches in the horse, ox, and dog, soon ulcerate out, seldom remaining longer than the third or fourth day at farthest. It therefore is the more necessary to be careful, that by perfect rest, and the appropriation of good bandages, we secure the wound from distortion. In this we may be assisted by strips of sticking plaster, made with diachylon and pitch: but these strips should be guarded from touching the wound itself by means of lint or tow first put over it. When, in addition to laceration in a wound, there is a destruction of substance, then the caution of washing will not apply, as it will be necessary to bathe with some warming spirit, as, *tincture of myrrh*, *tincture of aloe*, or *friars' balsam*, to assist in restoring the life of the part, and in preventing mortification. Bleeding must be stopped by pressure and astringents, as powdered alum: when it is very considerable, the vessel from whence the blood comes must be taken up. When great inflammation follows wounds or bruises, counteract it by bleeding, a cooling temperature, opening medicines, and continual fomentations to the part itself.

### SUBJECT. 2. *Balls and Drinks.*

5863. *Mode of giving a ball.* Back the horse in his stall, and being elevated on a stool, (not a bucket turned up side down,) gently draw the tongue a little out of the mouth, so as to prevent its rising to resist the passage of the hand: the tongue should however not be laid hold of alone, but it should be held firmly by the fingers of the left hand against the jaw. The ball previously oiled, being taken into the right hand, which should be squeezed into as narrow a shape as possible, must be passed up close to the roof of the mouth, and the ball placed on the root of the tongue, when both hands being withdrawn, it will readily pass down. This mode is much preferable, when a person is at all handy, to using a balling iron. At Long's, veterinary surgeons' instrument maker, is sold a clever machine for this purpose.

5864. *Mode of giving a drink.* Exactly the same process is pursued, except that a horn holding the liquid matter is forced up the mouth; the passage being raised beyond the level line, the liquid is poured out from the larger end of the horn, and when the tongue is loosened it is swallowed. Clark, however, ingeniously proposes to substitute the smaller end of the horn, the larger being closed, by which, he says, the horn can be forced up the mouth between the teeth, and poured farther back so as to ensure its not returning.

### SUBJECT. 3. *Fomentations and Poultices.*

5865. *Fomentations* are very commonly recommended of various herbs, as rue, chamomile, St. John's wort, wormwood, bay leaves, &c.; but the principal virtue is to be found in warmth and moisture, which unload the vessels: but this warmth ought not to be too considerable, except when the inflammation is within, as in inflamed bowels. Here we foment to stimulate the skin, and cannot foment too hot: but when we do it at once to an inflamed part, it ought not to be more than of blood heat; and it should be continued long, and when removed the part should be dried or covered, or cold may be taken, and the inflammation increased instead of diminished. *Anodyne fomentations* are made of poppy heads, and of tobacco, and are frequently of great use.

5866. *The method of applying fomentations* is conveniently done by means of two large woollen cloths wrung out of the heated liquors; as one is cooling the other should be ready to be applied.

5867. *Poultices* act in the same way as fomentations in allaying irritation and inflammation; but are in some respects more convenient, because they act continually. It is an error to suppose that poultices, to be beneficial, should be very hot: however hot they may be applied, they soon become of the temperature of the surrounding parts. When poultices are applied to the extremities, a stocking, as has been before stated, is a convenient method of application. When it is drawn over the leg and bound around the lower part of the hoof, or of the pastern, or otherwise, the matter of the poultice may be put within, and it may be then kept in its situation, if high up on the extremity, by means of tape fastened to one part of it, and passed over the withers or back to the other side, and again fastened to the stocking. In this way, also, loose bandages may be retained from slipping down. *Cold poultices* are often useful in the inflammations arising from strains, &c. In these cases bran and gould water form a convenient medium: but when the poultice is necessarily hot, a little linseed meal added to the bran will render it adhesive, and give it consistence. It is a very necessary caution in this, as in every instance where bandages are wanted around the extremities, to have them broad, and only so tight as to secure the matters contained, as in a poultice, or as in common bandaging. It is often supposed that "as strong as a horse," denotes that nothing can be too strong for him, nor any means too violent to hurt him. The horse, on the contrary, is one of the most tender animals alive; and a string tied very tight round the leg would occasion, first a falling off of the hoof, next a mortification of the rest of the limb, and lastly the death of the animal; and all this as certainly as though he were shot with a bullet through the head.

### SUBJECT. 4. *Setons and Rowels.*

5868. *Setons* are often useful in keeping up a drain to draw what are termed humors from parts; or by their irritations on one part, they lessen the inflammation in another part not very remote, as when applied in the cheek for ophthalmia or inflamed eyes. They also in the same way lessen old swellings by exciting absorption. Another useful action they have is to make a dependent or convenient orifice for the escape of lodged matter: thus a seton passed from the upper part of the opening of pole evil, through the upper part of the integuments of the neck, as low as the sinuses run, will often effect a cure without farther application. The same with fistulous withers, which sometimes run under the shoulder blade, and appear at the arm point; in which cases a blunt seton needle, of sufficient length to be passed down to that point, and to be then cut down upon, will form the only efficient mode of treatment. Setons may be passed in domestic farriery, with a common packing needle and a skain of thread, or piece of tape: but in professional farriery they are made by a proper needle armed with tape or lamp cotton, or skains of thread or silk smeared over with digestive ointment. When the seton needle is removed, the ends of the tape should be joined together, or otherwise knotted, to prevent them from coming out.

5869. *Rowels* in their intention act as setons, and as irritating a larger surface, so when a general drain is required they act better; as in grease, &c.: but when their action is confined to a part only, setons are more convenient. Any person may apply a rowel by making an incision in the loose skin about an inch, separating with the finger its adherences around, and then inserting in the opening a piece of round leather with a hole in the middle smeared with a blistering ointment. Then plug the opening with tow, and in three days, when the suppuration has begun, remove it. The rowel leather is afterwards to be daily moved and cleaned.

SUBJECT. 5. *Blistering and Firing.*

5870. *Blistering* answers the same purposes as setons; and is practised by first cutting or shaving the hair from the part, when the blistering ointment (*Vet. Pharm.* 5890.) should be well rubbed in for ten minutes, or a quarter of an hour. Some of the ointment after the rubbing may be smeared over the part. The head of the horse should now be tied up to prevent his gnawing or licking. If a neck cradle be at hand it may also for safety be put on; in which case the head may let down the third day.

5871. *A neck cradle for blistered horses* is very convenient for other occasions also, when the mouth is to be kept from licking or biting other parts; or to keep other parts from being rubbed against the head. It is of very simple construction, and may be made by a dozen pieces of wood of about an inch and half diameter, as old broom handles, &c. These bored at each end admit a rope to be passed through; and as each is passed on, a knot may be tied to the upper part of the pieces of the cradle, two inches apart; and those which form the lower part, four inches: by which means the neck will be fitted by the cradle when it is put on; and the horse will be prevented from bending his head to lick or gnaw parts to be protected. When the lower parts of the legs, particularly of the hinder, require blistering, it is necessary to bear in mind that in gross full horses, particularly in autumn, grease is very apt to follow blistering; and almost certainly if the back of the heels below the fetlock be blistered. First, therefore, smear this part over with lard or suet; and afterwards avoid touching it with the ointment. After blistering in summer, the horse is often turned out before the blistered parts are quite sound; in this case guard them from flies by some kind of covering, or they may become fly-blown; and likewise the fourth or fifth day rub into the blistered part some oil or lard to prevent the skin from cracking.

5872. *Sweating or liquid blisters* (*Vet. Pharm.* 5894.) are only more gentle stimulants, which are daily applied to produce the same effects on a diseased part without removing the hair. Of course less activity is expected; yet as the action is repeated, they are often more beneficial even than blistering itself: as in old strains and stiffnesses.

5873. *Firing*, as requiring the assistance of an experienced practitioner, we shall not describe; it will be only prudent to point out that it is a more active mode of blistering; and that it acts very powerfully as a stimulant, not only while its effects last as blisters do, but also after its escharotic effect is over, by its pressure; and in this way it is that it operates so favorably in bony exostosis, as splints and spavins; and in this way it is so useful in old ligamentary weaknesses; because by lessening the dilatibility of the skin it becomes a continual bandage to the part.

SUBJECT. 6. *Clystering and Physicking.*

5874. *Clystering* should always be preceded by *back-raking*, which consists in oiling one hand and arm, and passing them up the fundament, and by that means to remove all the dung balls that can be reached. The large pewter syringe for clystering, is neither a useful or safe machine. A much better consists in a turned box pipe, to which may be attached a large pig or ox-bladder, by which four or five quarts of liquid can be administered at one time. (*Vet. Pharm.* 5895. to 5898.) The pipe should be previously oiled, by which means it passes more easily: the liquor should then be steadily pressed up; and when the pipe is removed, the tail should be held down over the fundament a little to prevent the return of the clyster. In some cases of a spasmodic nature, as gripes and locked jaw, great force is made by the bowels to return the clyster, and nothing but continued pressure over the fundament can enable it to be retained. *Clysters* not only act in relaxing the bowels, but they may be used as means of nutriment when it cannot be taken by the mouth; as in locked jaw, wounds of the mouth, throat, &c., &c. In locked jaw, it was observed by Gibson, that he kept a horse alive many days by clysters alone: and by clysters also, many medicines may be given more conveniently than by the mouth.

5875. *Physicking of horses.* It is equally an error to refrain altogether from giving horses physic, as it is to give it on every occasion, as some do. Neither is it necessary for horses to be bled and physicked every spring and autumn, if they be in perfect health, and the less so, as at this time they are generally weak and faint from the change going on in their coats. Nor is it always necessary to give horses physic when they come from grass or a straw yard; provided the change from the one state to the other be very moderately brought about. But on such a removal, it certainly expedites all the phenomena of condition, (5754.), and such horses are less likely to *fall to pieces*, as it is termed, afterwards. (5755.) In various morbid states physic is particularly useful, as in worms, hide-bound, from too full a habit, &c. &c. It is not advisable to physic horses in either very cold, or very warm weather. Strong physic is always hurtful: all that physic can do is as well operated by a mild as by a strong dose, with infinitely less hazard. No horse should be physicked whose bowels have not been previously prepared by mashing for two days at least before. By these means the physic will work kindly, and a moderate quantity only is requisite. Most of the articles put into the purging balls for horses, to assist the aloes, are useless. Jalap will not purge a horse, nor rhubarb either. Aloes are the only proper drug to be depended on for this purpose, and of all the varieties of aloes the socotorine and Cape are the best. (*Vet. Pharm.* 5915.) Barbadoes aloes are also not improper, but are thought more rough than the socotorine. For formulae of purging balls, see *Vet. Pharm.* (5915.) Blaine gives the following as the process.

5876. *Physicking process.* The horse having fasted an hour or two in the morning from food, but having had his water as usual; give him his purge, and two hours after offer him a little chilled, but not warm water, as is often done, by which horses are disgusted from taking any: it may be here remarked that in this particular much error is frequently committed. Many horses will drink water with the chill taken off, provided it be perfectly clean, and do not smell of smoke from the fire, kettle, or saucen: but few, very few, will drink warm or hot water; and still fewer, if it be in the least degree greasy or smoky. After the ball has been given two hours, a warm bran mash may be offered, and a very little hay. He should have walking exercise as usual, moderately clothed: and altogether he should be kept rather more warm than usual. At noon mash again, and give a little hay, which should be repeated at night, giving him at intervals chilled water. On the following morning the physic may be expected to work; which if it do briskly, keep the horse quiet: but should it not move his bowels, or only relax them, walk him quietly half an hour, which will probably have the desired effect. Continue to give mashes and warm water, repeating them every two or three hours to support him. When physic gripes a horse, give him a clyster of warm water, and hand rub the belly, as well as walk him out. If the griping prove severe, give him four ounces of gin in half a pint of sound ale, which will soon relieve him. On the next day the physic will probably *set*, but should it continue to work him severely, pour down some boiled starch; and if this fail, turn to the directions under diarrhoea. (5804.) The horse should return to his usual habits of full feeding, and full exercise by degrees; and if more than one dose be to be given, a week should intervene. It is often requisite to make the second and third doses rather stronger than the first. A very mild dose of physic is likewise often given to horses while at grass in very warm weather, and without any injury. When worms, or skin foulness are present, and mercurial physic is deemed necessary, it is better to give two drachms of calomel in a mash the previous night, than to put it into the purging ball.

SUBJECT. 7. *Castration, Nicking, Docking, &c.*

5877. *The operations of castration, docking, nicking, and that of cropping* (which is now seldom practised), all require the assistance of a veterinary surgeon; and it is only necessary to remark of them, that the after treatment must be the same as in all other wounds. To avoid irritation, to preserve a cool temperature and a moderate diet; and if active febrile symptoms make their appearance, to obviate them by bleeding, &c., &c. It likewise is proper to direct the attention of the agriculturist who attends to these

matters himself, that the moment the wound following any of these operations looks otherwise than healthy, locked jaw is to be feared, and no time should be lost in seeking the best assistance that can be obtained. (5763.)

SUBJECT. 8. *Bleeding.*

5878. *Bleeding* is a very common, and to the horse a very important operation, because his inflammatory diseases, on account of the great strength of his arterial system, run to a fatal termination very soon, and can only be checked in the rapidity of their progress, by abstracting blood, which diminishes the momentum of circulation. Bleeding is more particularly important in the inflammatory diseases of the horse; because we cannot, as in the human, lower the circulation by readily nauseating the stomach. Bleeding also lessens irritation particularly in the young and plethoric, or those of full habit: hence we bleed in spasms of the bowels, in locked jaw, &c., with good effect. Bleeding is general or topical. *General*, as from the neck, when we mean to lessen the general momentum. *Topical*, when we bleed from a particular part, as the eye, the plate vein, the toe, &c. Most expert practitioners use a large lancet to bleed with; and when the habit of using it is acquired, it is by far the best instrument, particularly for superficial veins where a blow might carry the fleam through the vessel. In common hands the fleam (*fig. 623.*), as the more general instrument, is best adapted to the usual cases requiring the agriculturist's notice. Care should, however, be taken not to strike it with vehemence; and the hair being first wetted and smoothed down, it should be pressed close between the hairs, so that its progress may not be impeded by them. A ligature should be first passed round the neck, and a hand held over the eye, unless the operator be very expert, when the use of the fingers will dispense with the ligature. The quantity of blood taken is usually too small. In inflammatory diseases, a large horse, particularly in the early stage of a complaint, will bear to lose eight or ten quarts: and half the quantity may be taken away two or three times afterwards, if the violence of the symptoms seem to require it; and the blood should be drawn in a large stream to do all the good it is capable of. After the bleeding is finished, introduce a sharp pin, and avoid drawing the skin away from the vein while pinning, which lets the blood escape between the vein and skin: wrap round a piece of tow or hemp, and next day remove the pin, which might otherwise inflame the neck. In drawing blood, let it always be measured: letting it fall on the ground prevents the ascertaining the quantity; it also prevents any observation on the state of the blood, which if it form itself into a cup-like cavity on its surface, and exhibit a tough yellow crust over this cavity, it betokens an inflammatory state of body that will require further bleedings, unless the weakness forbid. After the bleeding, it now and then happens, from rusty lancets, too violent a stroke with the blood stick, or from drawing away the skin too much while pinning up, that the orifice inflames and hardens, and ichor is seen to ooze out between its edges. Immediately this is discovered, recourse must be had to an able veterinary surgeon, or the horse will lose the vein, and perhaps his life.

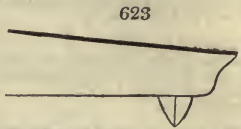

SECT. VII. *The Veterinary Pharmacopeia.*

5879. The following *formulæ* for veterinary practice have been compiled from the works of the most eminent veterinary writers of the present day, as Blaine, Clark, Laurence, Peel, White, &c.; and we can from our own experience also, confidently recommend the selection to the notice of agriculturists, and the owners of horses in general. It would be prudent for such as have many horses, and particularly for such as live at a distance from the assistance of an able veterinarian, to keep the more necessary articles by them in case of emergence: some venders of horse drugs keep veterinary medicine chests; and where the compositions can be depended on, and the un-compounded drugs are genuine and good, one of these is a most convenient appendage to every stable. The best arranged veterinary medicine chest we have seen, was in London, at the veterinary laboratory of Youatt of Nassau Street, Middlesex Hospital.

5880. *The veterinary pharmacopeia for oxen, calves, and sheep* has been included in the arrangement. When any speciality occurs, or where distinct recipes are requisite, they have been carefully noticed; it will therefore only be necessary to be kept in mind, that with the exception of acrid substances, as mineral acids, &c., which no cattle bear with equal impunity with the horse; the remedies prescribed require about the following proportions. A large ox will bear the proportions of a moderate sized horse; a moderate sized cow something less; a calf about a third of the quantity; and a sheep about a quarter, or at most a third of the proportions directed for the cow. It is also to be remarked, that the degrees in strength in the different recipes, are usually regulated by their numbers, the mildest standing first.

5881. *Alteratives.*

- 1. Levigated antimony, 2 drachms.
  - Creas of tartar,
  - Flower of sulphur, each half an ounce.
  - 2.
  - Cream of tartar,
  - Nitre, of each half an ounce.
  - 3.
  - Æthiops mineral,
  - Levigated antimony,
  - Powdered resin, each 3 drachms.
- Give in a mash, or in corn and bran a little wetted, every night, or make into a ball with honey.

- 2.
- Winter's bark in powder, 3 drachms.
- Green vitriol, do., one and a half drachm.
- Gentian, do. 3 drachms.
- Make either of these into a ball with honey, and give every morning.
- 3.
- White vitriol, 1 drachm.
- Ginger or pimento ground, 2 drachms.
- Powdered quassa, half an ounce.
- Ale, 8 ounces. — Mix, and give as a drink.
- 4.
- Arsenic, 10 grains.
- Oatmeal, 1 ounce.
- Mix, and give in mash or moistened corn nightly.

5882. *Tonic Alteratives.*

- 1.
- Gentian,
- Aloes,
- Ginger.
- Blue vitriol, in powder, of each 1 drachm.
- Oak bark in powder, 6 drachms.

5883. *Astringent Mixtures for Diarrhœa, Lax, or Scouring.*
- 1.
  - Powdered ipecacuanha, 1 drachm.
  - Do., opium, half a drachm.
  - Prepared chalk, 2 ounces.
  - Boiled starch, 1 pint.

<sup>2.</sup>  
Suet, 4 ounces; boiled in  
Milk, 8 ounces.  
Boiled starch, 6 ounces.  
Powdered alum, 1 drachm.

The following has been very strongly recommended in some cases, for the lax of horses and cattle.

<sup>3.</sup>  
Glauber's salts, 2 ounces.  
Epsom do., 1 ounce.  
Green vitriol, 4 grains.  
Gruel, half a pint.

When the lax or scouring at all approaches to dysentery or molten grease, the following drink should be first given.

<sup>4.</sup>  
Castor oil, 4 ounces.  
Glauber's salts (dissolved), 2 ounces.  
Powdered rhubarb, half a drachm.  
Powdered opium, 4 grains.  
Gruel, 1 pint.

5884. *Astringent Balls for Diabctes or Pissing Evil.*  
Catechu (Japan earth), half an ounce.  
Alum powdered, half a drachm.  
Sugar of lead, 10 grains.  
Conserve of roses to make a ball.

5885. *Astringent Paste for Thrush, Foot-rot, Foul in the Foot, &c.*

Prepared calamine,  
Verdigris, of each half an ounce.  
White vitriol,  
Alum, of each half a drachm.  
Tar, 3 ounces: mix.

5886. *Astringent Washes for Cracks in the Heels, Wounds, &c.*

<sup>1.</sup>  
Sugar of lead, 2 drachms.  
White vitriol, 1 drachm.  
Strong infusion of oak, or elm bark, 1 pint: mix.

<sup>2.</sup>  
Green vitriol, 1 drachm.  
Infusion of galls, half a pint.  
Mix, and wash the parts three times a day.

5887. *Powder for Cracks, &c.*

<sup>3.</sup>  
Prepared calamine, 1 ounce.  
Fuller's earth, powdered,  
Pipe clay, do., of each 2 ounces.  
Mix, and put within gauze and dab the moist surfaces of the sores frequently.

5888. *Astringent Paste for Grease.*

<sup>1.</sup>  
Prepared calamine,  
Tutty powdered,  
Charcoal, do. of each 2 ounces.  
Yeast enough to make a paste.

<sup>2.</sup>  
To the above, if more strength be required, add of alum and verdigris, each a drachm.

5889. *Astringent Wash for Do.*

<sup>3.</sup>  
Corrosive sublimate, 2 drachms.  
Spirit of wine or brandy, 1 ounce.  
Soft water, 10 ounces.  
Rub the sublimate in a mortar with the spirit till dissolved, then add the water. This is a strong preparation, and has often proved successful in very bad cases of grease, which have resisted all the usual remedies.

5890. *Blisters.*

<sup>1.</sup> A general one.  
Cantharides powdered, 2 ounces.  
Venice turpentine, do.  
Resin, do.  
Palm oil or lard, 2 lbs.  
Melt the three latter articles together, and when not too hot stir in the Spanish flies.

<sup>2.</sup>  
5891. *A strong cheap Blister, but not proper to be used in Fevers or Inflammations, as of the Lungs, Bowels, &c.*  
Euphorbium powdered, 1 ounce.  
Oil of vitriol, 2 scruples.

Spanish flies, 6 ounces.  
Palm oil or lard,  
Resin, of each, 1 lb.  
Oil of turpentine, 3 ounces.

Melt the resin with the lard or palm oil. Having previously mixed the oil of vitriol with an ounce of water gradually, as gradually add this mixture to the melted mass; which again set on a very slow fire for ten minutes more: afterwards remove the whole, and when beginning to cool, add the powders previously mixed together.

<sup>3.</sup>  
5892. *A Mercurial Blister for Splints, Spavins, and Rhngbones.*

Of either of the above, 4 ounces.  
Corrosive sublimate, finely powdered, half a drachm

<sup>4.</sup>  
5893. *Strong Liquid Blister.*

Spanish flies in gross powder, 1 ounce.  
Oil of origanum, 2 drachms.  
Oil of turpentine, 4 ounces.  
Olive oil, 2 ounces.  
Steep the flies in the turpentine three weeks, strain off, and add the oil.

<sup>5.</sup>  
5894. *Mild Liquid or Sweating Blister.*

Of the above, 1 ounce.  
Olive oil or goose grease, one and a half ounce.

5895. *Clysters, a, Laxative one.*

<sup>1.</sup>  
Thin gruel or broth, 5 quarts.  
Epsom or common salts, 6 ounces.

5896. *Clyster for Gripes.*

<sup>2.</sup>  
Mash two moderate sized onions,  
Pour over them oil of turpentine, 2 ounces.  
Capsicum, or pepper, half an ounce.  
Thin gruel, 4 quarts.

5897. *Nutritious Clyster.*

<sup>3.</sup>  
Thick gruel, 3 quarts.  
Strong sound ale, 1 quart.  
or 4.  
Strong broth, 2 quarts.  
Thickened milk, 2 quarts.

5898. *Astringent Clyster.*

<sup>5.</sup>  
Tripe liquor, or suet boiled in milk, 3 pints.  
Thick starch, 2 pints.  
Laudanum, half an ounce.  
or 6.  
Alum whey, 1 quart.  
Boiled starch, 2 quarts.

5899. *Cordial Balls.*

Gentian powdered, 4 ounces.  
Ginger, do., 2 ounces.  
Coriander seeds, do., 4 ounces.  
Caraway, do. 4 ounces.  
Oil of aniseed, a quarter of an ounce.  
Make into a mass with honey, treacle, or lard, and give one ounce and a half for a dose.

5900. *Chronic Cough Balls.*

<sup>1.</sup>  
Calomel, 1 scruple.  
Gum ammoniacum,  
Horse radish, of each 2 drachms.  
Balsam of Tolu,  
Squills, each 1 drachm.  
Beat all together, and make into a ball with honey, and give every morning fasting.

5901. *Drink for the same.*

<sup>2.</sup>  
Tar water,  
Lime water, of each half a pint.  
Tincture of squills, half an ounce.

5902. *Powder for the same.*

<sup>3.</sup>  
Tartar emetic, 2 drachms.  
Powdered foxglove, half a drachm.  
Powdered squill, half a drachm.  
Calomel, 1 scruple.  
Nitre, 3 drachms.  
Give every night in a malt mash.



5903. *Diuretic Balls.*

Resin, yellow, 1 lb.  
 Nitre, half a pound.  
 Horse turpentine, half a pound.  
 Yellow soap, quarter of a pound.  
 Melt the resin, soap, and turpentine over a slow fire; when cooling, add the nitre. For a strong dose, an ounce and a half, for a mild one an ounce. It should be kept in mind, that mild diuretics are always equal to what is required; and that strong diuretics are always hurtful.

5904. *Diuretic Powders.*

Yellow resin, powdered, 4 ounces.  
 Nitre, ditto, 8 ounces.  
 Cream of tartar, ditto, 4 ounces.  
 Dose—6, 8, or 10 drachms nightly, which some horses will readily eat in a mash.

5905. *Urine Drink.*

Glauber's salts, 2 ounces.  
 Nitre, 6 drachms.  
 Dissolve in a pint of warm water.

5906. *Embrocations.—Cooling for Inflammations.*

1.  
 Goulard's extract, half an ounce.  
 Spirit of wine or brandy, 1 ounce.  
 Soft water, 1 quart.

2.  
 Mindererus spirit, 4 ounces.  
 Water, 12 ounces.

5907. *For Strains.*

Bay salt, bruised, half a pound.  
 Crude sal ammoniac, 2 ounces.  
 Sugar of lead, quarter of an ounce.  
 Vinegar, 1 pint and a half.  
 Water, 1 pint.

5908. *For the Eyes.*

1.  
 Sugar of lead, 1 drachm.  
 White vitriol, 2 scruples.  
 Water, 1 pint.

2.  
 Brandy, 1 ounce.  
 Infusion of green tea, 4 ounces.  
 Tincture of opium, 2 drachms.  
 Infusion of red roses, 4 ounces.

3.  
 Rose water, 6 ounces.  
 Mindererus spirit, 3 ounces.

4.  
 Corrosive sublimate, 4 grains.  
 Alcohol, 1 ounce.  
 Lime water, 1 pint.

5.  
 Alum, powdered, 1 drachm.  
 Calomel, half a drachm.

Mix, and insert a little at one corner of the eye. The custom of blowing it in alarms the horse.

5909. *Fever Powders.*

1.  
 Tartar emetic, 2 drachms.  
 Nitre, 5 drachms.

2.  
 Antimonial powder, 2 drachms.  
 Cream of tartar,  
 Nitre, of each 4 drachms.

5910. *Fever Drink.*

3.  
 Sweet spirit of nitre, 1 ounce.  
 Mindererus spirit, 6 ounces.  
 Water, 4 ounces.

5911. *Epidemic Fever Drink.*

4.  
 Sweet spirit of nitre, 1 ounce.  
 Simple oxymel, 6 ounces.  
 Tartar emetic, 3 drachms.

5912. *Malignant Epidemic Fever.*

5.  
 Simple oxymel,  
 Mindererus spirit,  
 Beer yeast, of each 4 ounces.  
 Sweet spirit of nitre, 1 ounce.

5913. *Fumigations for purifying infected Stables, Sheds, &c.,*  
 Manganese, 2 ounces.

Common salt, ditto.  
 Oil of vitriol, 3 ounces.  
 Water, 1 ounce.

Put the mixed manganese and salt into a bason; then, having before mixed the vitriol and water very gradually, pour them by means of tongs, or any thing that will enable you to stand at a sufficient distance, on the articles in the bason gradually. As soon as the fumes rise, retire and shut up the door close.

5914. *Hoof Liquid.*

Oil of turpentine, 4 ounces.  
 Tar, 4 ounces.  
 Whale oil, 8 ounces.

This softens and toughens the hoofs extremely, when brushed over them night and morning.

5915. *Purging Medicines.*

Balls—very mild.

Aloes, powdered, 6 drachms.  
 Oil of turpentine, 1 drachm.

Mild.

Aloes, powdered, 8 drachms.  
 Oil of turpentine, 1 drachm.

Strong.

Aloes, powdered, 10 drachms.  
 Oil of turpentine, 1 drachm.

The aloes may be beaten with treacle to a mass, adding, during the beating, the oil of turpentine. All spices, oil of tartar, cream of tartar, jalap, &c. are useless, and often hurtful additions.

5916. *Liquid Purge.*

Epsom salts dissolved, 8 ounces.  
 Castor oil, 4 ounces.  
 Watery tincture of aloes, 8 ounces.

Mix.—The watery tincture of aloes is made by beating powdered aloes with the yolk of egg, adding water by degrees; by these means half an ounce of aloes may be suspended in eight ounces of water; and such a purge is useful when a ball cannot be got down, as in partial locked jaw.

5917. *Scalding Mixture for Pale Evil.*

Corrosive sublimate, finely powdered, 1 drachm.  
 Yellow basilicon, 4 ounces.

5918. *Foot Stoppings.*

Horse and cow dung, each about 2 lbs.  
 Tar, half a pound.

5919. *Wash for coring out, destroying Fungus, or proud Flesh, &c., &c.*

Lunar caustic, 1 drachm.  
 Water, 2 ounces.

5920. *Wash for Mange.*

Corrosive sublimate, 2 drachms.  
 Spirit of wine or brandy, 1 ounce.  
 Decoction of tobacco,  
 Ditto of white hellebore, of each 1 pint.  
 Dissolve the mercury in the spirit, and then add the decoctions.

5921. *Ointments for Healing.*

1.  
 Turner's cerate, 4 ounces.  
 White vitriol powdered, half a drachm.  
 Lard, 4 ounces.

5922. *For Digesting.*

2.  
 Turner's cerate, 2 ounces.  
 White vitriol, 1 drachm.  
 Yellow basilicon, 5 ounces.

5923. *For Mange.*

Sulphur vivum, 8 ounces.  
 Arsenic in powder, 2 drachms.  
 Mercurial ointment, 2 ounces.  
 Turpentine, 2 ounces.  
 Lard, 8 ounces.

Mix, and dress with every morning.

5924. *For Scab or Shab in Sheep, Mollenders and Scallenders in Horses, and foul Blotches and Eruptions in Cattle in general.*

Camphor, 1 drachm.  
 Sugar of lead, half a drachm.  
 Mercurial ointment, 1 ounce.

SECT. VIII. *The Shoeing of Horses.*

5925. *The importance of the subject of shoeing to the agriculturist is sufficiently attested by the immense number of inventions which the ingenuity of philosophers and artists are every day devising, to render the system complete. Almost every veterinary professor has his favorite shoe; and we find one of the most ingenious of the present day endeavoring to force on our notice, and introduce into our stables the French method; which, with the exception of the mode of nailing on, White observes, is the very worst he ever saw. The French shoe (fig. 624 a) has a wide web towards the toe, and is concave above, and convex below (b), on the ground surface, by which neither the toe nor heel touch the ground (c); but the horse stands pretty much in the same way with an unhappy cat, shod by unlucky boys with walnut shells. But as Blaine observes, in reference to these inventions, "No one form of foot defence can be offered as an universal pattern." It is, he continues, plain that the principles of shoeing ought to be those that allow as little departure from nature as circumstances will justify. The practice also should be strictly consonant to the principles; and both ought to consist, first, in removing no parts but those which, if the bare hoof were applied to natural ground, would remove of themselves. Secondly, in bringing such parts in contact with the ground (generally speaking) as are opposed to it in an unshod state; and above all, to endeavor to preserve the original form of the foot, by framing the shoe thereto; but never to alter the foot to the defence. The shoe at present made at the forges of the most respectable smiths in the cities and large towns throughout the kingdom, if it have not all the requisites, is, however, so much improved on, that with some alterations, not difficult either to direct or adopt, is the one we shall hold up as the most eligible for general shoeing. It is not that a better might not be offered to the notice; and in fact such a one we shall present to our readers; but so averse are the generality of smiths to have any improvements forced on them, and so obstinately determined are they to adhere to the forms handed down to them by their forefathers, that their stupidity or malevolence, or both, frequently makes the improvement itself, when seemingly acquiesced in, a source of irreparable injury. It is for these reasons we would recommend to agriculturists in general, a modified shoe of the common stamp.*

5926. *The improved shoe for general use (fig. 625.), is rather wider than what is usually made. Its nail holes (a) extend no further towards the heels than is actually necessary for security; by which the expansion of these parts is encouraged, and contraction is avoided. To strengthen the attachment, and to make up for this liberty given to the heels, the nails should be carried around the front of the shoe (c). The nail holes, on the under or ground surface of the shoe (a), are usually formed in a gutter, technically called the *fullering*; but in the case of heavy treading powerful horses, this gutter may be omitted, or if adopted, the shoe in that part may be steeled. The web, should be quite even on the foot or hoof surface (b), and not only be rather wider, but it should also have rather more substance than is common: from half an inch to five eighths in thickness, according to circumstance, forms a fair proportion; when it is less it is apt, in wearing, to bend to pressure and force out the clinches. A great error is committed in setting shoes out so much wider than the heels themselves: this error has been devised to correct another, which has been that of letting horses go too long without shoeing; in which case, if the heels of the shoe were not too wide originally, as the foot grew, they became lost within the heels; and thus bruised and produced corns: but as we will suppose that few will wish to enter into a certain error to avoid an uncertain one, so we recommend that the heels of the shoe should stand only wide enough to prevent the expansion of the quarters pushing the heels of the feet over the outer edge of the heels of the shoe: for which purpose if the iron project rather less than a quarter of an inch, instead of three-eighths, or even half an inch, as it frequently does, many advantages will be gained. Whoever attentively examines a shoe *well set off* at the heels, as it is termed, will find only one third of its flat surface protecting the heels; the remainder projects beyond, and serves but to form a shelf to lodge dirt on; or as a convenient clip for another horse to tread on; or for the wearer to cut his own legs with; or to afford a more ready hold for the suction of clayey*

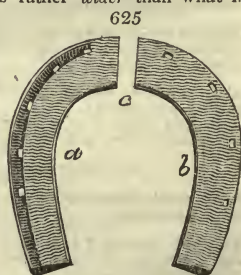

grounds to force off the shoe by. The heels of the common shoe are likewise not in general sufficiently long for the protection of the foot; and which defect, more than a want of width, causes the tendency to press on the crust of the heels. It is further to be observed, that if the decreased width of the outer standing of the heels, and the increased width of the web, should make the inner angle of the shoe heel in danger of interfering with the frog, the corner may be taken off. In forging this shoe, it may be bevelled, or left plane on both surfaces, or rather nearly so, for it is usual with most smiths to thin it in some degree towards the inner edge. This shoe is applicable to most feet, is easily formed, and as such, in country places is all that can be expected.

5927. *The injurious effects of bad shoeing* would only require to be known to excite every endeavor to obviate them; and there are some circumstances in the more common shoes of country smiths, that ought to be impressed on the mind of every agriculturist, and guarded against by every one who possesses a horse. It is too frequently observed that the ground side of their shoe is convex, and that the inward rim, when the foot is on the ground, is the lowest part; on which it is evident the weight must first press; and by which pressure, the crust will be forcibly thrust on the extreme edge of the shoe; and the only resistance offered to its being forced from it, depends on the nails and clinches, instead of its just application to the ground, and the support derived from the uniform pressure of the whole. Every shoe should therefore be perfectly level on its ground surface: nor should any shoe be put on that has not been tried on a *plane iron* purposely made for such trial; which irons are kept in some smithies, but are absent from too many. The substance of the shoe should be the same throughout, forming two parallel lines of upper and under surface; in plain language, the heels, instead of being clubbed as is too frequent, should be the exact thickness of the toe. Neither should the width at the heels diminish in the proportion it usually does; on the contrary, for a perfectly formed foot, the web should present an uniform width throughout.

5928. *Varieties in form of foot, differences in size, weight, and uses of horses,* will necessarily make deviations in the form and substance of shoes. The very shoe recommended may be considered as a variation from what would be immediately necessary, were the feet generally perfect; but it is to be considered that there are but very few feet but what have undergone some unfavorable alteration in their form, which makes them very sensible to concussion. It is for this reason, therefore, that it is recommended, that a shoe be used, for general purposes, somewhat wider and thicker than the common one. In weak, tender, flexible feet, it will be found particularly advantageous; and here the benefit of wide heels to the shoe will be most apparent. Good as the roads now are, yet most horses are occasionally subjected to travel on bad ones; some know no other: to these the addition of one, or at the most, two ounces to each shoe is nothing; but the ease to the horse, and its superior covering, as well as support, is incalculable. In very young, very light, and very firm feet, the width and substance may be somewhat diminished at pleasure, and particularly in situations where the roads are uniformly good; but a very long and extensive experience has assured us, that the shoe portrayed, is one well calculated to meet the ordinary purposes of travelling, and the present state of the art of horse shoeing.

5929. *An improved shoe on the present plan* (fig. 626.), would be found to unite all the perfections of the modern English improvements, with some derived from our neighbors the French. What has since been called a *seated shoe* was introduced by Osmer; but from the obstinacy and ignorance of smiths, as it could not be brought into general use, it became little thought of, until revived by Clark of Edinburgh; by whom it was patronized and recommended. It finally was taken up by Moorcroft, and has ever since attracted some attention, and continues to be forged in some shops where the work is superiorly done; and where the employers have liberality enough to pay for such work, and judgment enough to discriminate between its advantages and those of the common shoe. If to this shoe were added the French mode of fastening it to the foot, we think the improvement would almost shut out all others. On examining the figure it will be seen that this shoe presents a flat surface opposed to the ground (a), but a concave one towards the sole (b); but that this concavity does not begin, as in some seated shoes near the outer edge, but embraces two thirds only of the web, leaving by this means a sufficient surface for the crust: but this bevelling is not intended to reach the heels; it stops short of them (c), leaving the web at this part plane for the heels to rest upon. The

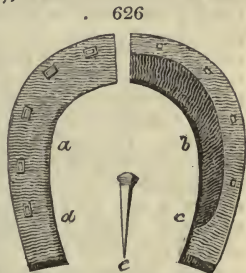

626

great advantages of this seating are, first, that as the crust rests on a flat surface instead of an inclined plane, as most of the common forged shoes present, so its position is maintained entire, and the inclination to contraction is in a great degree avoided. The nailing on of this shoe we would recommend to be after the French method, which consists in conical nail holes, punched with a square countersink (*d*), into which are received conical nails (*e*), which exactly fill up the countersink; by which means so long as any part of the base of the nail remains, the shoe must be held firmly on, and which is not the only advantage gained; for the nail holes being obliquely formed, and at some distance from the outer rim, act less detrimentally on the crust of the foot.

5930. *To prepare the foot for the application of the shoe* is also an important consideration. Avoid taking off more than one shoe at a time; otherwise the edges of the crust become broken away. Observe that the clinches are all carefully removed. Let the rough edges of the crust be rasped away; after which, the sole should be pared throughout until a strong pressure with the thumb can produce some yielding: too strong a sole tends to heat and contraction, too weak a one will not require paring. In this paring imitate the natural arch of the sole as much as possible. The line of concavity should not begin, as it usually is made to do, from the extreme margin of the foot, but should begin from the inner line of the crust only; by which means the crust, or outer wall of the hoof, will have a firm bearing on the flat surface of the shoe. Let no heated shoe be applied to correct the inequalities that may be left, unless it is for a moment, only to observe, but not burn them; but still more carefully avoid putting a plane shoe on an uneven foot. The portion of sole between the bars and quarters (*fig. 622 d*) should be always pared out as the surest preventive against corns. The heels also should be reduced to the general level of the foot, never allowing their hardness to serve as an excuse for being left; neither suffer the inner heel to be lowered more than the outer. After all the rest has been done, the frog should be so trimmed as to remain on an exact level with the returns of the heels, and no more. The custom of taking away the point or angle of the horny inflexions of the heels, under the false term of opening the heels, is to be carefully avoided. Let all these operations be performed with a drawing knife. The butteris should never be allowed to come near the foot of any horse but the largest and coarsest of the cart breed.

5931. *The shoes for the hind feet are somewhat different to the fore*, being a little squarer at the toe for about an inch; to which squareness the hoof is to be also adapted by rasping it slightly so, avoiding, however, to do it injuriously. By this mode a steady point of bearing is afforded to the hinder feet in the great exertions they are often called upon to make in galloping, leaping, &c. They are, when thus formed, less liable, also, to interfere with the fore shoes by clicking. When horses *click* or *over-reach* very much, it is also common to square, or rather to shorten the toes of the hinder shoes; but not to do so by the horn; by which, the hoof meets the middle of the fore shoe instead of the shoe itself; and the unpleasant noise of the stroke or click of one foot against the other is avoided.

5932. *Varieties which necessarily occur in shoeing.* The *bar shoe* (*fig. 627.*), is the most important variety, and it is to be regretted that so much prejudice prevails against the use of this shoe, which can only arise from its supposed unsightly appearance as betokening unsoundness. As a defence to weak thin feet it is invaluable, as it removes a part of the pressure from the heels and quarters, which can ill bear it, to the frog which can well bear it; but a well formed bar shoe should not have its barred part raised into an edge behind, but such part should be of one uniform thickness throughout the web of the bar, which, instead of being the narrowest, should be the widest part of the shoe. The thickness of the bar should be greater or less (*a*), so as to be adapted to take only a moderate pressure from the frog. When the frog is altogether ulcerated away by thrush, the bar may be altogether plain; but this form of shoe is still the best for these cases, as it prevents the tender surface from being wounded. In corns this shoe is invaluable, and may then be so made as to lie off the affected part, which is the great desideratum in corns.

5933. *The hunting shoe* is made lighter than the common one, and it is of consequence, that it is made to sit as flat to the foot as it can safely do without pressing on the sole: by which the great suction in clayey grounds is much lessened. Hunting fore shoes should also be as short at the heels as is consistent with safety to the foot, to avoid the danger of being pulled off by the hinder shoes: nor should the web project at all. It is the custom to turn up the outer heel to prevent slipping; which is done sometimes to both fore and hind feet, and sometimes only to the latter. As this precaution can hardly be avoided in hilly slippery grounds, it should be rendered as little hurtful

627

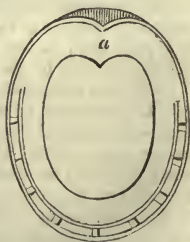

as possible by making the tread equal; to which purpose, thicken the inner heel and turn up the outer. This is better than lowering the outer heel to receive the shoe, which still leaves both the tread and foot uneven.

5934. *The racing shoe, or plate*, is one made as light and slender as will bear the weight of the horse, and the operations of forging, grooving, and punching: to enable it to do which, it ought to be made of the very best Swedish iron. Three, or at most four nails, are sufficient on each side; and to avoid the interfering of the hind with the fore feet, the heels of the fore shoes are made as short as they can safely be. As racers are shod in the stable, the owners should be doubly careful that the plate is an exact fit. Many pairs ought to be brought and tried before any are suffered to be put on, and which is more important than is at first considered.

5935. *Grass shoes or tips* are very short pieces placed on the toe alone, in horses turned to grass in summer; at which time they are essentially necessary to guard the fore feet, which otherwise become broken away, and irretrievably injured. They should be looked at occasionally to see that they do not indent themselves into the soles.

5936. *Frost shoes*, (fig. 628 a) have the ends turned up to prevent the foot from sliding; unless the turning up or calkin be hardened, they soon wear level and require to be renewed, to the injury of the foot by such frequent removals. To remedy this, many inventions have been tried; one of the best of these is that of Dr. Moore, in which the frost clip is made distinct and moveable by means of a female screw (b) worked in it, to which a knob or wedge (c), and male screw (d) are adapted; a key (e) being used for fixing or removing it.

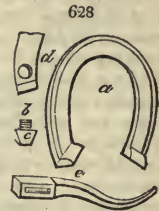

5937. *High calkins*, or turn ups, however objectionable in general shoeing, yet, in precipitous counties, as those of Devonshire, Yorkshire, and of Scotland, &c., are absolutely necessary for their draught horses. It greatly obviates the evils of uneven pressure, if a calkin be also put to the toe; and it would be still better were these calkins steeled, particularly the fore ones.

5938. *The shoeing of diseased feet* is necessarily very various, and is too often left to the discretion of the smith, by which the evils themselves are greatly aggravated, if he be ignorant. The most prominent alterations for these purposes will be found described under the respective diseases of the feet requiring them.

5939. *Horse pattens* are in use by some cultivators who occupy soft or mossy soils. Those esteemed the best are constructed of alder or elm, and are fixed to the hoof by means of three links and a staple, through each of which passes a leathern strap that goes twice round the hoof, and is fastened by a buckle. The staple is placed behind the patten, which is ten inches one way, by ten and a half the other. The links are about three inches in length, and rivetted through pieces of hoop iron to prevent the wood from splitting. After numerous trials it has been found that pattens made in this way, answer the purpose better than any other kind. (*Farm. Mag.*)

#### SECT. IX. *Criteria of the Qualities of Horses for various purposes.*

5940. *The general criteria of the qualities of a horse* are derived from inspection and trial. His outward appearance among judges affords a pretty just criterion of his powers, and a moderate trial usually enables the same judgment to decide on the disposition to exercise such powers.

5941. *The criteria of a horse derived from his color* have been already noticed. (5629.) As a general principle dark are preferable to light horses, except in the instance of black, which has fewer good horses within its range, particularly in the lighter breeds, than any other. Grey horses are also, in some degree, an exception to the rule; for there are many good greys. Bay and brown are always esteemed colors.

5942. *The criteria of action* are derived from a due consideration of the form generally, and of the limbs particularly; as well as from seeing the horse perform his paces in hand.

5943. *The criteria of hardihood* are derived from the form of the carcase, which should be circular, or barrelled; by which, food is retained, and strength gained, to perform what is required. Such horses are also generally good feeders.

5944. *The criteria of spirit, vigor, or mettle*, as it is termed, are best derived from trial. It should always be kept in mind, that a hot fiery horse is as objectionable as a horse of good courage is desirable. Hot horses may be known by their disinclination to stand still; by their mettle being raised by the slightest exercise, especially when in company. Such horses seldom last long, and under accident are impetuous and frightened in the extreme. A good couraged horse, on the contrary, moves with readiness as well alone as in company: he carries one ear forward and one backward; is attentive and cheerful, loves to be talked to, and carressed even while on his journey; and

if in double harness, will play with his mate. Good couraged horses are always the best tempered, and, under difficulties, are by far the most quiet, and least disposed to do mischief.

5945. *The criteria of a race-horse*, derived from form, are, that he have the greatest possible quantity of bone, muscle, and sinew, in the most condensed form. There should be a general length of parts to afford stretch, scope, and elasticity, with great muscles hardened by condition, to act on the length of these parts advantageously. In particular his hind-limbs should be furnished with ample thighs, and broad hocks, which should be low set. His fore arm ought also to be broad, and the knee, like the hock, should be near the ground.

5946. *The criteria of a hunter* are, that he have somewhat similar proportions with the racer, but with more bulk to enable him to continue his exertions longer, and to carry more weight. In him, a good carcass is essentially necessary to fit him to go through a long chase; and the more, if he be required to hunt more than one or two days in the week. Some light carcassed horses will do one day's hunting work a week very well; but knock up at more. The hunter should be well formed in his loins, and well let down in his thighs to propel him forward in his gallop, and give him strength to rise sufficiently to cover his leaps. It is also of great use to a hunter to be a good trotter; many such horses, when fatigued, break out of the gallop and relieve themselves by trotting, particularly over heavy ground.

5947. *The criteria of a hackney*. If it be necessary that the hackney be well formed behind to give him strength, and to propel him forward, it is even of more consequence that he be well formed before; and in this kind of horse the hind parts are in some measure subordinate to the fore, as safety is preferable to speed. The head in the hackney should be small, and well placed on a neck of due length and substance to make a proper appui for the bridle; and that proper resistance to the hand, so pleasant to the feel, and so necessary for ease and safety. The shoulders should be oblique and well furnished with muscle, but not heavy; and the withers in particular should be high. The elbows should be turned rather out than in, and the legs should stand out straight, and by no means fall under the horse, or it betokens a stumbler. The pasterns should neither be too oblique, which bespeaks weakness; nor too straight, which wears the horse out, and is unpleasant to the rider. The carcass should be round, or the horse will be washy and weak; the loins straight, wide, and ribbed home; the thighs of good substance; and although the being cat-hammed, or having the hocks turned inwards, is defective in beauty, it often bespeaks a trotter.

5948. *The criteria of a cavalry horse* are, that he have considerable extension of bulk or size, to enable him to carry weight, with good carcass to allow him to feed coarsely, and yet thrive at piquet or on service. He should have also liberty of action; but great speed is not requisite. The best cavalry horses are those formed of the united properties of hackneys, and very light draught horses.

5949. *The criteria of road horses for quick draught*, or coach, chariot, stage and post chaises, &c., are derived from the immediate purposes for which they are intended; as requiring either strength or speed in greater proportions. To make them safe, the fore-hand should rise, the back should be straight, the step should be short but quick, which fatigues least. As they approach the hunter in form, they are best fitted for quick work; and as they resemble the best kind of light agricultural horses, they are calculated for heavy draught, as coaches, &c. But in all, a portion of blood gives courage, durability, and condenses strength into lessened bulk; by which activity is gained. It is of great consequence to a coach-horse that the neck and head be so formed as to be enabled to rein-in well to the bridle.

5950. *The criteria of a dray-horse* are, that he be very broad-breasted and muscular, and thick in the shoulders, which should not lie backward. Nor should the fore-hand be up, as recommended in the road-horse; for, by holding up their heads, such horses may be choked by the collar, as they would, if so formed, draw too much by the throat, and their wind being thus stopped, would be in danger of falling down. The neck of a dray-horse is not the better for being long, and the head should be proportionate to it. Like all horses, he should be chosen with short legs, and good strong hoofs. He ought to be thick in his thighs, and large in bone; but above all, he ought to be a steady collared horse, with courage to make him true to a severe pull; and yet, without a hot fiery spirit to make him fretful.

5951. *The criteria of a waggon-horse* are, in some respects, different from those of the dray-horse. He should be more weighty, and altogether larger. Rapidity of motion is greatly subordinate, in the heavy stage-waggons usually seen on our roads, to strength. It is all collar work; nothing is gained from the momentum of the dragged mass, which, the instant the pull ceases, stands still. The waggon horse should be patient in the extreme; willing to lie to his collar up hill, and yet settle into his own share of work on level ground. As his exertions are constant, it is of the greatest consequence that he be a good feeder.

5952. *The criteria of a horse peculiarly adapted to the labors of agriculture*, are thus given by Culley. His head should be as small as the proportion of the animal will admit; his nostrils expanded, and muzzle fine; his eyes cheerful and prominent; his ears small, upright, and placed near together; his neck, rising out from between his shoulders with an easy tapering curve, must join gracefully to the head; his shoulders, being well

thrown back, must also go into his neck (at what is called the points) unperceived, which perhaps facilitates the going much more than the narrow shoulder; the arm, or fore-thigh, should be muscular, and tapering from the shoulder, to meet a fine, straight, sinewy, and bony leg; the hoof circular, and wide at the heel; his chest deep, and full at the girth; his loins or fillets broad and straight, and body round; his hips or hooks by no means wide, but quarters long, and the tail set on so as to be nearly in the same right line as his back; his thighs strong and muscular; his legs clean and fine-boned; the leg-bones not round, but what is called *lathy* or flat.

5953. *The chief points in a farming cart-horse*, in the opinion of the author of the *New Farmer's Calendar*, are, "neck not long, nor too thick; short legs, rather flat than round and gummy; fore-feet even, not too distant; wide chest; strong, but not high, shoulders; considerable length of waist, supported by a wide loin; quarters full, and rather raised; strong muscular thigh; size, fifteen hands one inch, to sixteen hands high. Being somewhat forelow, gives them an advantage in draught; and a moderate length of waist insures speed in the walk.

5954. *The horse used in husbandry*, according to the writer of the *Experienced Farmer*, ought to be larger, but in other respects like the road horse; and, instead of walking two or three miles an hour, be able to walk four or five. In that case he would be able both to plough more land in a given time, and work in the cart or wagon with more dispatch, when wanted. In harvest time, a nimble and strong horse is valuable. In drawing manure into the field, or corn to the market, the farmer will also find his account in strength and activity; for, as the draught in all these cases is light one way, such horses would do their business with speed. The small farmer need not with this kind of horse keep an idle one; he might carry his master to market, and plough the remainder of the week.

5955. *In a horse for the plough*, according to Brown, both strength and agility are required; a dash of blood, therefore, is not disadvantageous. It is not size that confers strength, the largest horses being often soonest worn out. A quick even step, an easy movement, and a good temper, are qualities of the greatest importance to a working horse; and the possession of them is of more avail than big bones, long legs, and a lumpy carcass. To feed well is also a property of great value; and this property, as all judges know, depends much upon the shape of the barrel, deepness of chest, strength of back, and size of the hips or hooks with which the animal is furnished. If straight in the back, and not over short, high in the ribs, and with hooks close and round, the animal is generally hardy, capable of undergoing a great deal of fatigue, without lessening his appetite, or impairing his working powers; whereas horses that are sharp pointed, flat ribbed, hollow backed, and wide set in the hooks, are usually bad feeders, and soon done up when put to hard work.

5956. *The criteria of a horse's age* are derived from the appearance of the teeth. According to La Fosse the younger, there are these appearances. The horse is foaled with six molar or grinding teeth in each jaw (*fig. 629 a*); the tenth or twelfth day after, the

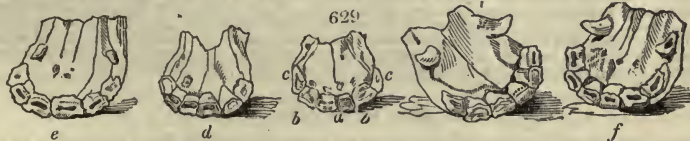

two front nippers (*a*) appear above and below, and in fourteen or fifteen days from this, the two intermediate (*b b*) are pushed out; the corner ones (*c c*) are not cut till three months after. At ten months the incisive or nippers are on a level with each other, the front less than the middle, and these again less than the corners; they at this time have a very sensible cavity (*d*). At twelve months this cavity becomes smaller, and the animal appears with four molar teeth on each side, above and below, three of the temporary or colts', and one permanent or horse tooth: at eighteen the cavity in the nippers is filled up, and there are five grinders, two of the horse, and three temporary: at two years, (*fig. 630.*) the first of the colt's molar teeth in each jaw, above and below, are

630



displaced: at two years and a half, or three years, the front nippers fall and give

place to the permanent ones: at three and a half the middle nippers are likewise removed, at which period the second milk-molar falls: at four years, the horse is found with six molar teeth, five of his new set, and one of his last: at four years and a half the corner nippers of the colt fall and give place to the permanent set (*fig. 629 e*), and the last temporary grinder disappears: at five years old the tushes in the horse usually appear: at five and a half they are completely out, and the internal wall of the upper nippers, which before was incompletely formed, is now on a level with the rest; at this period the incisive or nippers have all of them a cavity formed in the substance between the inner and outer walls, (*fig. 629 f*) and it is the disappearance of this that marks the age: at six years those in the front nippers below are filled up, (*fig. 630 e*) the tushes are likewise slightly blunted: at seven years the mark or cavity in the middle nippers is filled up, and the tushes a little more worn (*fig. 630 f*): at eight years old the corner nippers are likewise plain, and the tushes are round and shortened. (*fig. 630 g*) In mares, the incisive or nippers alone present a criterion (*fig. 630 a*); at this period the horse is said to be aged, and to have lost his mark; but among good judges the teeth still exhibit sufficient indications. At nine the groove in the tushes is worn away nearly, and the nippers become rather rounded: at ten these appearances are still stronger: at twelve the tushes only exhibit a rounded stump, the nippers push forward, become yellow, and as the age advances, appear triangular and usually uneven.

5957. *M. St. Bel*, the late professor of the English Veterinary College, used to assert, that after eight years the cavities in the anterior or upper incisive teeth, are filled up with equal regularity; thus from eight to ten the front ones were filled up, from ten to twelve the two middle, and from twelve to fourteen those of the corner; but though some pains have been taken to ascertain this, it does not appear that the disappearance of the cavities in these teeth is attended with sufficient regularity to warrant implicit confidence.

5958. *To make a colt appear older than he really is*, both breeders and dealers very commonly draw the nippers, particularly the corner ones; by which means the permanent set which are underneath immediately appear, and the animal is thus fitted for sale before he otherwise would be.

5959. *To make a horse look younger than he really is*, dealers perform an operation on the teeth called bishopping (from the name of a noted operator); which consists in making an artificial cavity in the nippers, after the natural one has been worn out by age, by means of a hard sharp tool; which cavity is then burned black by a heated instrument. But no art can restore the tushes to their form and height, as well as their internal grooves. It is, therefore, common to see the best judges thrust their finger into a horse's mouth, contenting themselves with merely feeling the tush. To less experienced judges other appearances present themselves as aids. Horses, when aged, usually become hollow above the eyes, the hoofs appear rugged, the under lip falls, and if grey, they become white. In this country, where horses are so early worked before the frame is consolidated, and where afterwards they continue to be exerted unceasingly on hard roads, it is not uncommon to find a horse at six years old, feeble, debilitated, and exhibiting all the marks of old age, except in his mouth; on the contrary, when the animal falls into other hands, at ten or twelve he has all the vigor of youth, and his teeth are the only parts that present an indication of age: it is, therefore, more useful to examine the general appearance of the animal, than to be guided altogether by the marks in the teeth; a too strict adherence to which, Blaine observes, leads into great error on the subject of the age of horses. The commonly received marks, he says, grant not a criterion of a third of the natural life of the animal, nor of one half of the time in which he is perfectly useful. Many good judges will not purchase a horse for hunting earlier than eight years old, and regard him only in his prime at twelve. A gentleman at Dulwich has a monument to the memory of each of three several horses, which died in his possession at the age of thirty-five, thirty-seven, and thirty-nine years; the latter of which was suddenly taken off by a fit of colic, having been in harness but a few hours before. Culley mentions a horse of forty-five; and an instance lately occurred of one which lived to fifty. Blaine, in continuation, draws the following comparison between the relative situations of the state of the constitution, between the horse and man, under the ordinary circumstances of care towards each. The first five years of the horse, may be considered as equivalent to the first twenty of a man; a horse of ten as a man of forty; of fifteen as a man of fifty; of twenty as a man of sixty; of twenty-five as a man of seventy; of thirty as a man of eighty; and of thirty-five as a man of ninety. (*Vet. Outlines, p. 35.*)

#### SECT. X. *Of Breeding Horses.*

5960. *The general principles of breeding* we have already laid down at length, (1994.), and have here to notice what are considered the best practices in the choice of stallions and mares, and in the treatment of the latter during pregnancy. Unfortunately, however, much less attention has been paid to breeding horses, than to breeding cattle or sheep; though, as Brown has observed, a pound of horse flesh is worth two of that of any other stock; and it costs just as much to breed a bad horse as a good one. Every one, an eminent writer observes, exercises some degree of judgment in regard to the stallion; but there are few breeders, comparatively, who hesitate to employ very ill-formed and worthless mares, and often solely because they are unfit for any thing else than bringing a foal. All the best writers on agriculture reprobate this absurd and unprofitable practice. "In the midland counties of England, the breeding of cart horses is attended to with the same assiduity as that which has of late years been bestowed on cattle and sheep; while the breeding of saddle horses, hunters, and coach horses is almost entirely neglected; or left almost wholly to chance, even in Yorkshire, — I mean as to females. A breeder here would not give five guineas for the best brood mare in the kingdom, unless she could draw or carry him occasionally to market; nor a guinea extraordinary for one which could do both. He would sooner breed from a rip, which he happens to have upon his premises, though not worth a month's keep. But how absurd! The price of the leap, the keep of the mare, and the care and keep of her progeny, from the time they drop to the time of sale, are the same, whether they be



sold from ten to fifteen, or from forty to fifty pounds each." (*Marshal's Economy of Yorkshire*, vol. ii. p. 166.)

5961. *In those districts where the breeding of horses is carried on upon a large scale and a regular plan, the rearing of stallions forms in some degree a separate branch; and is confined, as in the case of bulls and rams, to a few eminent breeders.* These stallions, which are shown at the different towns in the vicinity, sometimes sent to be exhibited at a considerable distance, are let out for the whole season, or sold to stallion men, or kept by the breeder himself, for covering such mares as may be offered, at a certain price per head; and this varies according to the estimation in which the horse is held, and sometimes according as the mare has more or less of what is called blood. For farm mares, the charge for covering by a stallion of the same kind is commonly about a guinea, with half-a-crown to the groom; and it is a common practice in the north, to agree for a lower rate if the mare does not prove with foal; sometimes nothing more is paid in that case than the allowance to the groom.

5962. *In choosing the parents, or stallion and mare, regard must be had to the kind of stock desired to be bred.* Whatever may the particular purpose of the breed, a stallion ought first to possess all the general properties of a good horse, and next the characteristic criteria of the desired stock. The produce, whether a male or female, much more frequently acquires and retains the form, make, marks, and disposition of the sire than the dam. On this account, stallions with the least appearance of disease, blemish, or bodily defect of any kind, where there is the slightest probability of its being transmitted to the offspring, should be rejected as improper. And it is even considered by some, necessary to descend to the minutæ of symmetry in the head, neck, shoulder, forehead, ribs, back, loins, joints, and pasterns, attending even to a strict uniformity in the form, make, and texture of the hoofs: and, were it possible, even to ascertain the temper and disposition of both sire and dam, in order to avoid the procreation of vices or imperfections. But provided either parents be free from hereditary infirmities, disorders which arise from accident are of no consequence.

5963. *The general properties required in a breeding mare, are a good shape, a gentle disposition, a large carcass conformably to her height, and belly well let down; she must be perfectly free from all sorts of blemishes and defects.* The size, frame, bone, strength, and blood, will of course be regulated by the purposes of the breeder.

5964. *The mare which is intended to supply draught-colts should, according to the author of the Synopsis of Husbandry, be large limbed, close jointed, short decked, wide chested, home ribbed, with a capacious body; her eyes good, and her nostrils large and open; in disposition she ought to be gentle and tractable; of a constitution healthy and vigorous, free from any blemishes either hereditary or acquired.* The horse should be bold and spirited, well made, and of a kindly disposition; his constitution should be strong, his temper good, and, in short, neither in mind or body ought he to be contaminated with vices or disease of any kind; since on the good qualities and strength of constitution in the sire and the dam depends, in a great measure, the future welfare of the colt.

5965. *The age at which a stallion and mare should be allowed to copulate is not determined by uniform practice; and is made to depend, in some measure, on the degree of maturity, which, in animals of the same species, is more or less early, according to breed and feeding.* Yet it would seem, in general, to be an improper practice to allow animals of any kind to propagate, while they are themselves in a raw unformed state, and require all the nutriment which their food affords, for raising them to the ordinary size of the variety to which they belong. It may, therefore, be seldom advisable to employ the stallion till he is about four years old, or the mare till she is a year older, and if the stallion be five also it is better, and still more so if he be six or seven. But the greater number of mares left for breeding are not very young; being in many cases, not allowed to bring foals till they are in the decline of life, or otherwise unable to bear their full share in rural labor.

5966. *Three months before a stallion is to cover a mare, he should be fed with sound oats, peas, or beans, or with coarse bread, and a little hay, but a good quantity of wheat straw; he should be watered regularly, and have long continued walking exercise every day, but he should not be over heated.* If he be not prepared and put in condition, the colts will be likely to be weakly, and the horse himself will become injured, begetting humors, or becoming broken winded. If he be put to too many mares, he will not last long; his main and tail will begin to fall off through weakness, and it will be difficult to get up his flesh again by the next year. The number of mares should be proportioned to his strength, and twelve, fifteen, or at the most twenty are as many as a horse will well serve for in a season.

5967. *The usual season when a mare takes the horse is from the beginning of April to the beginning of July.* The month of June is considered the best season in this country; although from the middle to the end of May is more approved of on the Continent, particularly in Normandy, where the farmers devote much of their attention to this branch of husbandry; and in which, especially in regard to useful farm horses, they have succeeded, perhaps, beyond those in any other part of Europe. This difference, as to the time when a mare should be allowed to take the horse, in the different

countries, is easily reconcilable: a mare goes eleven months and a few days with foal; and the great object with all farmers, where practicable, is to have her covered at such a period as to ensure abundance of grass, and the return of warm and comfortable weather at the period of foaling. An early colt is always to be preferred to one that falls late in the season. It is generally understood, and is an opinion that is believed to be well founded, that a mare may be covered on the ninth day after she has foaled, with a greater degree of success than at any other period. This practice is, of course, often followed; but in such cases the mare ought, Donaldson thinks, to be fed in an extraordinary manner, otherwise it is impossible she can do justice to her present and her future foal. But modern farmers would probably, he says, come nearer their purpose, were they to follow the example of the Romans, and content themselves with one foal in the two years.

5968. *At the season of parturition, there should be a suitable supply of food for the mother and young.* The time of covering mares ought, therefore, to be partly regulated by a due regard to this circumstance, and may be earlier in the south than in the north, where grass, the most desirable food both for the dam and foal, does not come so early by a month or six weeks. In Scotland, it is not advantageous to have mares to drop their foals sooner than the middle of April; and as the period of gestation is about eleven months, they are usually covered in May, or early in June. But if mares are intended to bring a foal every year, they should be covered from the ninth to the eleventh day after foaling, whatever may be the time; and the horse should be brought to them again nine or eighteen days afterwards.

5969. *In breeding horses on a large scale, it is easy to contrive so that all the foals may be brought forth at a time when there is plenty of grass.* About the end of May the mares are to be put into an enclosure capable of feeding them as long as the stallion is to be with them, or that they are in season. In this enclosure all the mares are to be put together, as well those which are barren as others. The stallion's hind shoes are to be taken off, but the fore shoes should be left, or tips put on to preserve his feet; then lead him forth, and let him cover a mare twice in hand, to render him more tame and gentle. After this take off the bridle and turn him loose among the rest, where he will become familiar with them, and not one of them will be horsed but when they are in season. There should be a little lodge built up in some part of the enclosure, and peas, beans, oats, bread, and other good food, put into the manger in it, that the horse may retire into it in the scorching heats, and eat what he likes best. He must be thus entertained during the whole time he is with the mares, which is to be about six or seven weeks. Mares that are very fat and gross do not hold well; but those which are moderately fat conceive with the greatest success and ease.

5970. *To bring a mare in season, it is a common thing to give her a quart of hemp-seed, or twice that quantity, night and morning, for eight days before she is brought to the horse.* If she refuse it alone, it may be mixed with beans or oats, and will go down; and if the stallion eat of it also, it will force him also; but it must be remembered that these provocatives are unnatural, and often defeat their own purposes. They are therefore seldom now resorted to among intelligent breeders. Still more improper is it to attempt an early horsing, by injecting stimulating fluids up the vagina as is sometimes done; for when it succeeds, the future progeny seldom answers the expectation.

5971. *The treatment of a pregnant mare is in general little different from that of any other horse.* Mares of draught are worked in summer as usual, and more moderately in the ensuing winter, till near the time of foaling; when, if the season be somewhat advanced, even though the pasture be not fully sufficient for their maintenance, they should be turned out to some grass field near the homestead, and receive what additional supply of food may be necessary under sheds adjoining. It is both inconvenient and dangerous to confine a mare about to foal in a common stable, and still more so to leave her loose in a close stable among other horses; and confinement is not much less objectionable after dropping her foal.

5972. *Breeding mares are usually worked through the greatest part of the year, laying them aside only for a week or two before foaling, and during the summer season, when giving suck to the young foal.* In this way, Brown observes, the strength and vigor of the mother is not only weakened, but the size and power of the foal stand a great chance of being diminished, by the exertions of the mother when kept at work. Under these impressions we are led to consider the working of breeding mares as an unprofitable practice. Were they suffered to remain at ease, to roam upon coarse pastures, where sheds were erected in which they might find shelter during inclement weather, we are almost certain that their progeny would enter upon action with increased abilities. The expense of a breeding mare kept in this way would not be great, whilst the advantages would be innumerable. In Yorkshire, and in those midland counties where the breeding and rearing of horses is better understood than in any other part of the island, they are often worked till the very time of foaling. Great care, however, is necessary in working and managing a mare heavy with foal: an over-heat, too severe exercise, a fright, or a sudden and violent jerk, are very apt to cause an untimely birth, whereby the foal is lost, and the life of the mare very much endangered.

5973. *In the mountains of Wales, and in the Highlands of Scotland, the breeding mares are never worked during the summer. They are driven to the hills and mountains at the close of the barley-seed season, where they remain till the inclemency of the weather forces them to return for shelter. But their scanty subsistence, the labor they are subjected to in procuring their food, and the moistness and coldness of the climate in the latter part of the season, render both themselves and their progeny of but little value or importance.*

5974. *Breeding farms, consisting chiefly of pasture land unfit for feeding, are the situations where breeding is generally carried on. Arable farmers may breed occasionally; but the inconvenience of wanting any part of their working stock at the time of foaling operates almost as a prohibition to the breeding of horses. The greater number of horses are bred in situations where a small portion of arable land is attached to farms chiefly occupied with cattle or sheep; or where the farms are so small as not to afford full and constant employment to the number of horses that must, nevertheless, be kept for the labor of particular seasons.*

#### SECT. XI. *Of Rearing Horses.*

5975. *Rearing includes the treatment of the foal till it is fit to work, or to be put in training for use, and also the treatment of the mother till she has weaned her foal.*

5976. *In regard to the treatment of the mare till she has weaned her foal in England, and in the improved parts of Scotland, a mare after having foaled, is turned, together with the foal, into a pasture field, and is allowed two or three weeks' rest, before she is again worked, either in plough or cart; the foal being allowed to suckle at pleasure during the time. After having had a few weeks' rest, she is again worked in the usual manner; the foal being commonly shut up in a house during the hours of working. In Yorkshire, some farmers are particularly careful not to allow the mare to go near the foal, after her return from labor, till her udder has been bathed with cold water, and not till most of the milk is drawn from it. These precautions are used with a view of preventing any bad consequences from the foal's receiving over-heated milk. Another practice, and which is superior to the above, is also common in Yorkshire, and in many parts of Scotland: — after the foal is a few weeks old, and has acquired strength and agility enough to follow its mother, it is allowed to attend her in the field during the hours of labor, and to suckle occasionally. By this means, not only does the foal receive sufficient exercise; nor can any prejudicial effect happen from the over-heated state of the milk, as the foal is allowed to draw it off repeatedly, and at short intervals; but the little animal becomes hardy, and loses all timidity, and afterwards requires less breaking; these may be considered as the general modes of management in those parts of the kingdom mentioned above, during the period while the foal is allowed to suckle its dam, which is usually about six months; that is, from the time of foaling, till Michaelmas, which is the period at which foals are generally weaned, or prevented from sucking. Breeding mares are evidently unable to endure the fatigue of constant labor, for some months before and after parturition: this had led a few farmers to rear foals upon cow milk; but the practice is neither common nor likely ever to become so: and as it is a philosophical fact, well established, that all animals partake, in some measure, of the nature of their foster parent, so there is great reason to fear this practice would prove injurious to foals so reared.*

5977. *In weaning the foal at the end of six or seven months, great care should be taken to keep the mare and foal from the hearing of each other, that neither may fret or pine after the other. The best method will be to confine the foal in a small stable by itself, which should be furnished with a rack and manger, where it may be fed with clean shaken hay, and clean sifted oats, bruised a little in a mill, or chopped carrots, or boiled potatoes. With this management, he will quickly forget his dam, and become gentle and familiarised to his keeper, and in fair weather may be suffered to exercise himself in a pasture adjoining to the stable; but this should be only for a little while in the middle part of a sunny day; the tenderness of the young animal rendering it dangerous to keep him out in the night.*

5978. *The treatment of weaned foals in England, is to put them immediately into a good fresh pasture, where they remain as long as the winter continues moderate. On the approach of winter, they are fed with a sufficient quantity of hay, placed in a stable or hovel, erected in the field for the purpose, and into which they have free access at all times. The next summer they are put into other pastures, commonly the most indifferent on the farm, where they remain till the beginning of the following winter, when they are either allowed to range in the pasture fields, or brought home to the straw-yard. The inclemency of the winter in Scotland, and the great falls of snow which generally take place, render it necessary always to house the foals there during that season.*

5979. *During the first winter foals are fed on hay with a little corn, but should not be constantly confined to the stable; for even when there is nothing to be got on the fields, it is much in their favor to be allowed exercise out of doors. A considerable proportion of succulent food, such as potatoes, carrots, and Swedish turnips (oil cake has been recommended), should be given them through the next winter,*

and bean and peas meal has been advantageously substituted for oats, which, if allowed in a considerable quantity, are injurious to the thriving of the young animal, from their heating and astringent nature.

5980. *During the following summer* their pasture depends upon the circumstances of the farms on which they are reared. In the second winter they are fed in much the same manner as in the first, except that straw may be given for some months instead of hay; and in the third winter, they have a greater allowance of corn, as they are frequently worked at the harrows in the ensuing spring. (*General Report of Scotland*, vol. iii. p. 183.) When about three years old, the author of the *New Farmer's Calendar* advises foals to be fed all winter with a little corn twice a day, or carrots, with hay, oat-straw, &c. allowing a well-littered shed, or warm straw-yard. Colts fed at home with green meat, cut during summer, should have a daily range on a common, or elsewhere, for exercise. Yearlings to be carefully kept separate from the milch mares.

5981. *The time for gelding colts* is usually the same in both parts of the kingdom, which is, when they are about a year old; although, in Yorkshire, this operation is frequently suspended till the spring of the second year, especially when it is intended to keep them on hand, and without employing them in labor till the following season. Parkinson disapproves of delaying this operation so long, and recommends twitching the colts, a practice well known to the ram-breeders, any time after a week old, or as soon after as the testicles are come down; and this method, he says, he has followed himself, with great success. (*Parkinson on Live Stock*, vol. ii. p. 74.) Blaine's remarks on the subject of castration appear worthy of notice: he says, when the breed is particularly good, and many considerable expectations are formed on the colt, it is always prudent to wait till twelve months: at this period, if his fore parts are correspondent with his hinder, proceed to castrate; but if he be not sufficiently well up before, or his neck be too long and thin, and his shoulders spare, he will assuredly improve by being allowed to remain whole six or eight months longer.

Another writer suggests for experiment, the *spaying* of mares, thinking they would work better, and have more wind than geldings. (*Marshal's Yorkshire*, vol. ii. p. 169.) But he does not appear to have been aware that this is by no means a new experiment: for Tusser, who wrote in 1562, speaks of *gelding fillies* as a common practice at that period. The main objection to this operation is not that brood mares would become scarce, as he supposes, but that, by incapacitating them from breeding in case of accident, and in old age, the loss in this expensive species of live stock would be greatly enhanced. An old or lame mare would then be as worthless as an old or lame gelding is at present.

5982. *The rearing of horses* is carried on in some places in so systematical a manner, as to combine the profit arising from the advance in the age of the animals, with that of a moderate degree of labor, before they are fit for the purposes to which they are ultimately destined. In the ordinary practice of the midland counties, the breeders sell them while yearlings, or perhaps when foals, namely, at six or eighteen months old, but most generally the latter. They are mostly bought up by the graziers of Leicestershire, and the other grazing parts of that district, where they are *grown* among the grazing stock until the autumn following. At two years and a half old, they are bought up by the arable farmers, or dealers of Buckinghamshire, Berkshire, Wiltshire, and other western counties, when they are broken into harness, and worked till they are five, or more generally, six years old. At this age the dealers buy them up again to be sent to London, where they are finally purchased for drays, carts, waggons, coaches, the army, or any other purpose for which they are found fit. (*Marshal's Economy of the Midland Counties*, vol. i. p. 311.)

5983. In the west of Scotland, a similar *mode of transferring horses* from hand to hand, is common. The farmers of Ayrshire, and the counties adjacent, who generally grow corn on not more than one-fourth, or at the most, one-third of their arable land, and occupy the remainder with a dairy stock, purchase young horses at the fair of Lanark and Carnwath, before mentioned; work them at the harrows in the following spring when below two years old; put them to the plough next winter, at the age of two and a half, and continue to work them gently till they are five years old, when they are sold again at the Rutherglen and Glasgow markets at a great advance of price, to dealers and farmers from the south-eastern counties. A considerable number of horses, however, are now bred in the Lothians, Berwickshire, and Roxburghshire, the very high prices of late having rendered it profitable to them, even upon good arable ground; but many farmers of these counties, instead of breeding, still prefer purchasing two and a half or three and a half year old colts, at the markets in the west country, or at Newcastle fair, in October; they buy in a certain number yearly, and sell an equal number of their work horses before they are so old as to lose much of their value, so that their stock is kept up without any other loss than such as arises from accidents; and the greater price received for the horses they sell, is often sufficient to cover any such loss. (*General Report of Scotland*, vol. iii. p. 182.)

SECT. XII. *Of Training Horses.*

5984. *Horses are trained for various purposes*, but principally for carrying our persons or drawing our burdens. Formerly, burdens were principally borne on the back by pack-horses, but the improvements in our roads have removed them from the back, to machines called carriages, drawn by means of harness applied over the person of the horse. Under saddle, we train horses as racers, hunters, hacknies, or troop horses. In harness we use them in coaches, stages, chariots, and various lighter vehicles, or we employ them in waggons, carts, ploughs, and various other agricultural or commercial machines. Horses are held in obedience by means of bridles, with appendages called reins, which are long or short, as used in riding or driving. Horses are directed and urged forward by whip, spur, and language, and they are chastised by the same means.

5985. *The directive language used to horses ought to be everywhere the same*, which is the more easily accomplished, as words or phrases are sufficient for giving every requisite direction to a horse. The first of these words may be "on," or go on, or merely the common chuck of the tongue, &c. as used by all coachmen in the world; the second to make the horse go to the right-hand side, "right-hand;" the third, to the left-hand side, "left-hand;" the fourth to make them stop, may be "stop," or "stand still." Any attempt to modify these directions, ought to be given in the correct language of the country, and not in provincial words, as go on, slowly, briskly, right-hand, a little round, or turn, left-hand, a little, or left-hand and round, stop, or stand gently, &c. As a proof that only four words are requisite for giving every requisite direction to horses, we may mention that foreigners in Stockholm, Petersburg, and Moscow, who know nothing of the language, require only four corresponding words of Swedish or Russian, to direct the native coachmen and sledge drivers to any street, house, or place, the situation of which they know by the maps, or otherwise.

5986. *The three natural and ordinary movements of horses* are, walking, trotting, and galloping, to which, some horses naturally add another, which is known by the name of "ambling," or "pacing;" the trot is, perhaps, the most natural motion of a horse, but the pace, and even the gallop, are most easy to the rider.

5987. *In training saddle horses*, the first thing is to make them familiar with man, and other general objects, and which is best effected at the earliest periods, which then saves almost all the trouble of breaking, and docility follows as a matter of course: to effect this, the greatest kindness should be used to the colts from the moment they are dropped: they should be accustomed to be handled, should be fed with bread, patted in various parts of the body, have light matters put on their heads and backs, and subjects of different colors and forms should be shown them with caution. While at foot, the mare and foal should be led out into roads, and where carriages pass, during which time, nothing should be allowed to intimidate the foal. By this management, the animal will be easily prepared for the future operations; and it is thus that the single foal the ploughed land farmer breeds, and which daily follows the mother in her work, as it were breaks itself.

5988. *Backing* is the next operation, and if the colt has been judiciously used, and taught familiarity and docility by early handling and kindness, it is by no means difficult. It should be commenced before the colt is two and a half or three years old. The first backing of a horse is a thing of great consequence, as his value afterwards very much depends on it. The application of the saddle should be gradually done, and without alarm to the horse. After a colt has become habituated to the saddle and bridle, and has been exercised some time, morning and evening in them, and become somewhat obedient, he is to be taken to some ploughed lands, the lighter the better; he must be made to trot over these in the hand sufficient to slightly tire him. This should be at first done in a cavesson, to insure obedience. Care being taken that all the tackling be good and firm, and every thing in its due and proper place; then a person is to hold his head and another to mount him; but this must by no means be done suddenly, or at a jerk, but very gradually and slowly, by several risings and heavings. If he bear this patiently, the person is to seat himself firmly on his back; but if he be troublesome and not tame enough, the person is to forbear the attempt to mount, and he is to be trotted in the hand over the same ploughed lands again, till he is more fatigued and willing to receive the rider quietly on his back: when this is done, the person who is on his back must encourage him, and the man who has his head must lead him a few paces forward; all the while encouraging him. The feet are to be fitted well in the stirrups, and the toes turned out, afterwards the rider is to shrink and move himself in the saddle, and the person who holds his head is to withdraw his hand a little farther from the mouth. As the rider moves his toes forward, the holder must move him forward with the rein, till he is made to apprehend the rider's motion of body and foot, which must always go together, and with spirit, and will go forward without the other's assistance, and stay upon the restraint of the rider's hands. When this is accomplished, let him be cherished, and again have grass and bread to eat; and then let the rider mount and alight several times, encouraging him between each time, and thus he is to be managed till he will go on, or stand still at pleasure. This being done, the long rein may be laid aside, and the band about the neck, which are always used on this occasion, and nothing will be necessary but the trenches and cavesson, with the martingal. A groom must lead the way before; or another horse going only straight forwards, and making him stand still when desired. In this manner, by sometimes following, and sometimes going before another horse on the trot, the creature will by degrees be brought to know that it is his business to be quiet and governable.

5989. *To teach a horse the different movements of walking, trotting, galloping, and ambling*, comes next in order.

5990. *Walking* is the slowest and least raised of all a horse's movements. It is performed, as any one may observe, by the horse's lifting up its two legs on a side, the one after the other, beginning with the

hind leg first. Thus if he leads with the legs of the right side, then the first foot he lifts is the far hind foot, and in the time he is setting it down (which in a step is always short of the tread of his fore foot on the same side) he lifts his far fore foot, and sets it down before his near fore foot. Again, just as he is setting down his far fore foot, he lifts up his near hind foot, and sets it down again just short of his near fore foot; and just as he is setting it down, he lifts his near fore foot, and sets it down beyond his far fore foot. This is the true motion of a horse's legs in a walk; and this is the pace in which many things are best taught. For instance when the horse is to be taught to turn to the right and left, or from one hand to another, he is first to be taught it on the walk, then on the trot, and finally on the gallop. The walk is a pace to which team, carriage, and road horses should constantly be well broke, as being of great use in all such cases and intentions. It is an excellent pace too, in a saddle horse, when well performed by being properly taught.

5991. In trotting the limbs are diagonally employed; but their tenses or times, or rising and falling, are very different, as it is conducted slow or fast. In the slow trot the diagonal legs are elevated and replaced simultaneously; while those on the ground are preparing to elevate themselves, and the horse is for a moment on tiptoe; but until the original diagonal legs are set down, these are not wholly elevated; therefore the horse is during the moderate trot at no time without support. But it is very different when the trot is accelerated, as to nine or ten miles an hour; for then there is a period in every spring made by the diagonal members, when all the feet are in the air at the same time; and the body completely suspended from the ground by these means. Thus during this accelerated action, the off fore leg and near hind leg having been elevated in the air before they meet the ground, the near fore leg and the off hind one are not only prepared, as in the slow trot, to elevate themselves, but actually do so before the others are set down; consequently, the feet at this precise time, must be all in air. (fig. 631.) To speed in the trot, it is necessary that a horse pick up his feet quick, and extend them far forward. To the safety also, it is necessary he elevate his knee; at the same time the general elevation of the whole is operated by high withers, and oblique shoulders.

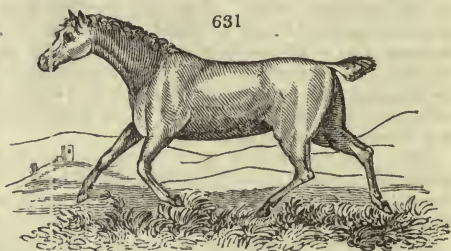

5992. Three qualities are essentially necessary to make the trot useful. It ought to be extended, supple, and even, or equal: these three qualities mutually depend upon each other, so that you cannot pass to the supple trot, without having first worked upon the extended trot; and you can never arrive at the even and equal trot, without having practised the supple. The extended trot is that in which the horse trots out without retaining himself, being quite straight and going directly forwards; and this consequently is the kind of trot with which you must begin. The supple trot is that in which the horse, at every motion he makes, bends and plays his joints by the elasticity of the organs composing them; as those of his shoulders, his knees, and feet, which no colts or raw horses can execute, who have not had their limbs suppled by exercise, and who always trot with a surprising stiffness and awkwardness, without the least spring or play in their joints. The even or equal trot is that in which the horse makes all his limbs and joints move so equally and exactly, that his legs never cover more ground one than the other, nor at one time more than another. To do this, the horse must necessarily unite and collect all his strength, and if the expression may be allowed, distribute it equally through all his joints. To go from the extended trot to the supple, you must gently and by degrees hold in your horse; and when by exercise he has attained sufficient ease and suppleness to manage his limbs readily, you must insensibly hold him in still more and more, and by degrees you will lead him to the equal trot.

5993. The manner of trotting a colt who has never been backed is as follows: put a plain snaffle in his mouth; fit a cavesson to his nose, to the ring of which tie a longe of a reasonable length. Let a groom hold this longe, who, having got at some distance from the colt, must stand still in the middle of the circle which the horse will make. Let another follow him with a long whip or chambrière in his hand. The colt being alarmed, will be forced to go forward, and to turn within the length of the cord, the groom must hold it tight in his hand; by this means he will draw in, or towards the centre, the head of the colt, and his croupe will of consequence be without the circle. In working a young horse after this manner do not press or hurry him. Let him walk first, and afterwards put him to the trot. If you neglect this method his legs will be embarrassed; he will lean on one side, and be more upon one haunch than the other; the inner fore foot will strike against the outer one, and the pain which this will occasion will drive him to seek some means of defence, and make him disobedient. If he refuses to trot, the person who holds the chambrière will animate him by trotting him, or striking the ground with it. If he offers to gallop instead of trotting, the groom must shake or jerk the cord that is tied to the cavesson, and he will fall into his trot. (Berenger's Art of Horsemanship, vol. i. ch. 4.) The value of this longing in a circle is incalculable, inasmuch as it supple the shoulders, and gives them a greater extent of action. It also increases the action of the whole limb downwards, and accustoms the horse to affect other movements, to be performed with an elevated hand.

5994. The gallop is the swiftest natural pace of a horse, performed by reaches or leaps; the two fore feet being raised almost at the same time; and when these are in the air, and just ready to touch the ground again, the two hind feet are lifted almost at once. In galloping, the horse may lead with which fore leg he pleases; the most usual way is that with the right, in which case the gallop is said to be just; but whichever it be, the hind leg of the same side must follow it next, which forms an even or equal gallop; otherwise the legs are said to be disunited, and the gallop to be false; to remedy which disorder, the rider must stay the horse a little on the hand, and help him on the spur on the contrary side to that on which he is disunited. However, this rule has not been always strictly observed; for hunting horses have been trained to lead indifferently with both legs, because it has been found, that a horse which has never been suffered to gallop but with his right fore leg, has been worn out on one side, when he has been fresh and sound on the other. In order to make a stop in a gallop straight forwards, the rider should carefully put his horse together, without altering or disturbing the appui, and throw his body back a little to accompany the action, and to relieve the horse's shoulders. In doing this he should seize the time of making the stop, keeping the hand and body quite still, exactly when he feels the horse put his fore feet to the ground, in order that by raising them immediately by the next motion which he makes, he may be upon

his haunches. When horses do not put out their strength sufficiently, they should be galloped briskly, and then slowly again by turns, and they will thus be compelled to obey the hand and heel. In the slow gallop, as well as in the trot, it is sometimes necessary to close the heels to the horse's sides, which is called *pinching*; but this should be done in such a manner as not to make the horse abandon himself upon the hand, and care must be taken that he be upon his haunches, and not upon his shoulders; and, therefore, when he is pinched, he should be kept in the hand. To put a horse well together, and make him bring his hinder legs under him, the rider must close his legs upon him, putting them very much back; this will oblige him to slide his legs under him; at the same instant let the hand be raised a little to support him before, and yielding again immediately. Let him be thus supported, and have the rein again from time to time, till he begins to play and bend his haunches, and gallops leaning and sitting down, as it were, upon them; let the rider then press him with the calves of his legs, and he will thus become quick and sensible to the touch. If a horse has too fine a mouth, gallop him upon sloping ground; this will oblige him to lean a little upon the hand, in order the better to put himself upon the haunches; and through fear of hurting his bars, he will be prevented from resisting the operation of the bit. If the horse is heavy in hand, gallop him up sloping ground; and when his appui is too strong, this will lighten him. The gallop serves to assure and make steady a weak and delicate mouth, and also to supple a horse, and make him steady and active in his limbs. (*Berenger's History and Art of Horsemanship*, vol. ii. p. 104, &c.)

5995. *In galloping in a circle* the horse is confined always to lead with his fore leg, within the turn; otherwise he is said to gallop false. But here, too, the hind leg of the same side must follow. The varieties of gallop are a *hand-gallop*, a *Canterbury-gallop*, a *school-gallop*, &c. A smooth gallop, close to the ground, the French call the English gallop, *galop à l'Anglois*.

5996. *The canter is different from the gallop* in some essential particulars. Whether the gallop be fast or slow, still the legs are at one period wholly removed from the ground, and the horse is all in air. In the canter, on the contrary, at no period is the horse completely elevated from the ground, but has always one or more points of contact with it. Blaine describes its operation thus: when performed on the right, the horse commences by first placing his off hind leg a little beyond the other; at nearly the same instant he elevates the fore hand, and places first the near fore leg on the ground; the off doubling over and beyond, is placed in an instant after it. In the next movement the hind legs are thrown in, and, while elevated, the off fore leg becomes raised from the ground; but the near fore leg is not elevated until the hinder ones are replaced. The near fore leg is, therefore, the whole point of support in cantering at each remove, and thus it is that cantering horses always first fall on that leg.

5997. *The amble* is a peculiar kind of pace, by which the horse changes sides at each remove; two legs of a side being always in the air, and two on the ground. An amble is usually the first natural pace of young colts, which, as soon as they have strength enough to trot, they quit. There is no such thing as an amble in the manege; the riding-masters allowing of no other paces beside walk, trot, and gallop; their reason is, that a horse may be put from a trot to a gallop, without stopping him; but not from an amble to a gallop without stopping. This movement, which is very laborious to the horse, and in which he ought not to be indulged, except on smooth ground, is very easy to the rider; it has not the hardness of a trot, because the hind leg moves along with the fore one, and creates no resistance to the motion. It is, however, now never taught, and therefore any directions regarding it would be useless.

5998. *The training of cavalry horses* is exclusively performed in the military establishments, and therefore can never be required of the farmer or breeder.

5999. *The training of coach horses* commences with taming, walking, trotting, and repeated longing; and next with yoking and driving in a break or four-wheeled frame, with no other load than that of the coach box or seat placed in the usual position, the driver and his assistant sitting on a board fixed to the perch or hind axle, in order to be ready at a moment's notice, to descend and re-strain, or direct the horses. Coach horses, from 15 to 16 hands high, should walk light five miles an hour, and trot twelve. They should be first accustomed to this exercise in the country, next in the outskirts of a large city, and lastly in the most crowded streets.

6000. *The age at which a horse is fit to be worked in a coach*, is four and a half or five years; but by the fraudulent practice both of the country and town dealers, horses of three and four years old are frequently employed. The first business of the Yorkshire dealer, who has three or four year old colts to dispose of, is to draw their corner teeth, in order to make them have the mouths of those of five. They also undergo the operation of docking and nicking; and after having been kept two or three months on mashes, made of bran, ground oats, or boiled corn, they are sold to the London dealers, who, it is said, sell these three or four year old horses as if they were five years old. They are then taken into immediate work, either for the coach or saddle; and in a few months are completely destroyed by this premature and too severe labor. The drawing of the teeth is not a fraud practised on the London dealers; they know the deception, and insist upon its being done by the country dealers. It is requisite to be done some months before the London dealers finally sell them for use, or the tooth which denotes a horse to be five years old would not be grown, consequently the deception could not have taken place.

6001. *The training of cart and plough horses* commences with taming before they are a year old, with walking and rubbing them down in the stable when they are two, and with training to work when they are of three years growth. They should be placed under the charge of a very steady careful servant, who will teach them to back, and to go into the shafts. They ought not, however, to be made to draw any other than a very light empty cart, till their fourth or fifth year; nor ought they to be put into the shafts of a threshing machine before their fifth year. The first work to which an agricultural horse may be applied, is harrowing; but this during the fourth year only half a day at a time, or with a light harrow the whole day. Next he may be put to plough with similar care and caution in regard to strength. In general, agricultural horses require very little training; but one thing is too often neglected, and that is, teaching plough horses a quick step, and keeping them at that step ever after in working them. By not attending

to this, and leaving the step to be regulated by lazy, spiritless ploughmen, the loss to many farmers is very considerable.

### SECT. XIII. *Of the Art of Horsemanship.*

6002. *Horsemanship, as an art,* is unquestionably of very ancient date, and it is curious how very different are the modes by which it is practised in different countries; but which differences are yet principally confined to the situation of the legs of the rider: for wherever the horse is used to carry the person, it is by the rider placing himself astride the animal. Horses were used in this way for centuries before any apparatus was used or applied to their bodies to spare fatigue to the rider; and we know that the first saddles were mere pads strapped round the body, but without the appendages of stirrups. In England, riding is systematically divided in two kinds, which are manege and jockey riding.

6003. *Manege riding,* called also *riding the great horse,* in the strict application of the term, was formerly more practised than at present; and required a system of education for both horse and rider long and severe. Horses perfectly broke for the manege, were taught several paces and motions, as ambling, pacing, passaging, yerking, capriole, and cornetti. The practice of these artificial cadences, it is supposed, injures the natural pace of the horse; and this circumstance, united to a particular form of horse (defective for other purposes) being required for the elasticity of these actions, has tended to bring manege riding, as formerly practised, into disrepute. Manege riding also taught the constant application of the seat of the body of the rider, to the seat of the saddle, during all the motions of the horse; and as a severe education, and a particular form, had bestowed ease and elasticity to the rudeness of the manege horse, the inconveniences of this seat were not felt. But when another form of horse, capable of great speed over excellent roads, was in general use, this kind of riding was found hurtful to both horse and rider; fatiguing the one, and injuring the other.

6004. *The art of proper riding,* as practised among experienced horsemen, is derived from a knowledge of the judicious application of the aids of the bridle, as taught in our schools, and as practised in the army generally: and also from a proper application or placing the body on the horse. These we certainly owe to manege riding; and a knowledge of them is as essential to the safety of the rider, as it is to the grace of his appearance as a horseman. The proper art of riding embraces all that is taught in the best schools, or practised on the road; and is equally applicable to both. This is allowed to its fullest extent by those who have possessed themselves of the requisite information, and practise on the subject; but is denied by those who, wedded to field riding, contend that the perfection of horsemanship consists in a snaffle bridle and a jockey seat.

6005. *The use of the curb bridle* is considered in the schools to be essential to good riding: by it the horse is not only restrained, but he is also aided and assisted. He is alternately thrown on his haunches, or forced on his forehead, by which changes fatigue is prevented to both. Great nicety, however, is required in the use of the curb; and without an inclination and ability to use it lightly and dexterously, a snaffle is the best and safest bridle. The curb is to be operated by a gentle turn of the wrist only; and the action of the hand in this respect should be as fine, and as pliable as the fishing rod and line. The force of the curb should in every instance be portioned to the mouth of the horse.

6006. *The best form of saddle* for general riding is one in which the cantle is not so high as the military, nor so low as the racing saddle. The pommel should be no more raised than is necessary to keep the whole completely free from the withers. The stirrups should be substantial, not only to prevent breaking; but also that by their weight they may fall to the foot when accidentally slipped away; which is of more consequence than at first sight may appear. If they are of the spring kind, it is also desirable: but it is still more so, that the spring stirrup leather should be used; which prevents the danger arising from horses catching the leather in the projections of doors, gates, &c. Having saddled and bridled our horse we will proceed to mount our rider.

6007. *If you would mount with ease and safety,* says Hughes, stand rather before the stirrup than behind it; then, with the left hand, take the bridle short, and the mane together, help yourself into the stirrup, with your right, so that, in mounting, your toe do not touch the horse. Your foot being in the stirrup, raise yourself till you face the side of the horse, and look directly across the saddle; then, with your right hand, lay hold of the hinder part of the saddle, and, with your left, lift yourself into it. When mounted, let your position on the saddle be square, and the purchase of your bridle such as not to pull your shoulders: and let your body be in such an even posture as if you held a rein in each hand.

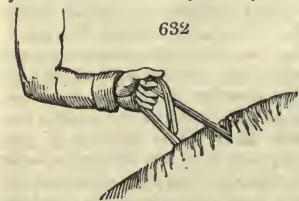

632

In holding the bridle, grasp the reins with your hand, which should be held perpendicular with the reins passed, the lower within the hand, and the upper, between the fore and next fingers. (*fig. 632.*) The reins are then brought over the fore finger and firmly held by the thumb. It is often directed to place the little finger between the lower reins; the practice of this may be optional with the rider, and in a very fine hand is desirable. The bridle should be held at such a length as to enable you if your horse stumbles, to raise his head and support it with your arms; and by throwing your body backwards at the same time you frequently save a horse that would otherwise fall.

6008. *A graceful and proper seat* on horseback is greatly dependent on a right disposition of the legs and thighs, which should hang nearly straight down, easily, and without force or constraint: all which is brought about from above; by placing the body flat and evenly on the saddle, and opening the knees, whereby the fork will come lower on the saddle. (*fig. 633.*) The thighs should be applied to the saddle and to the sides of the horse by their inner surfaces, so as to bring in the knees and toes; and although the line may be properly broken by some little irregularities, yet the foot, the knee, the hip, and shoulder, should deviate but little from one perpendicular line. The ball of the foot should rest within the stirrup, and should be even with the heel, or very slightly elevated above it. Avoid any stiffness in the legs, thighs, or body; all should be lax, but in a state to be able to embrace the horse, either for support, or as aids to him. The loins particularly, should be lax and pliable, as a coachman's on his box; and for the same reasons: for by sitting thus loosely, the rough motions of both are broken. To depend on the embrace of the knees for support, is to lose the benefit of a true equipoise of body, and is rather to stick on a horse than to sit on one.

6009. *When you are troubled with a horse that is vicious,* which stops short, or, by rising or kicking, endeavors to throw you off, you must not bend your body forward, as is commonly practised in such cases; because that motion throws the breech backward, and moves you from your fork, or twists and casts you out of your seat: but the right way to keep your seat, or to recover it when lost, is, to advance the lower part of your body, and to bend back your shoulders and upper part. In flying or standing leaps, a horseman's best security is the bending back of the body. The rising of the horse does not affect the rider's



633



seat; he is chiefly to guard against the lash of the animal's hind legs, which is best done by inclining the body backward. But the usual method of fixing the knees in all cases of danger only serves, in great shocks, to assist the violence of the fall. To save yourself from being hurt, in these cases, you must yield a little to the horse's motion; by which means you will recover your seat, if displaced, or keep it at such times as would dismount an unskilful horseman.

6010. *If your horse grows unruly*, take the reins separately, one in each hand, put your arms forward, and hold him short, but do not pull hard with your arms low; for, by lowering his head, he has the more liberty to throw out his heels: but if you raise his head as high as you can, this will prevent him from rising before or behind; nor, while his head is in this position, can he make either of these motions. Is it not reasonable to imagine, that, if a horse is forced towards a carriage which he has started at, he will think he is obliged to attack or run against it? Can it be imagined that the rider's spurring him on, with his face directly to it, he should understand as a sign to pass it? These rational queries are submitted to the serious consideration of such as are fond of always obliging their horses to touch those objects at which they are, or affect to be, frightened.

6011. *Indifferent horsemen*, Lawrence observes, should never venture on horseback without spurs. Those who reflect upon the predicament of being placed between a deep ditch and a carriage, at which their horse shies, will see the necessity of this precaution.

6012. *Previous to mounting*, every person will find his account in examining the state of both horse and furniture with his own eyes and hands; for, however good and careful his groom may generally be, it is a maxim, that too much ought not to be expected from the head of him who labors with his hands. Besides, all such sedulously avoid trouble, particularly in nice matters. For example, see that your curb is right, that your reins are not twisted, that your girths, one over the other, still bear exactly alike; that the pad be not wrinkled up; but, above all, that your saddle lies exactly level upon the horse's back.

6013. *On getting off the horse's back*, hold the bridle and mane in the same manner as when you mounted, hold the pommel of the saddle with your right-hand; to raise yourself, bring your right leg over the horse's back, let your right-hand hold the hind part of the saddle, and stand a moment on your stirrup, just as when you mounted. But beware that, in dismounting, you bend not your right knee, lest the horse should be touched by the spur.

6014. *The jockey mode of riding* is practised in its fullest extent in racing. With some modification it is also in use by many who esteem themselves excellent fox-hunters. English post-boys unite these two kinds of riding in a manner at once easy to themselves and horses. True jockey riding consists in the use of a snaffle bridle, which is held firmly; and, as an advocate for it expresses himself, to enable the rider to give his horse the proper pulls. To this end, the same writer recommends a firm seat, upright, and as you would sit in a chair, with the knees nearly as much bent, and turned inward; the toes somewhat out and upward; the leg falling nearly straight, and the foot home in the stirrup (*fig. 634.*); elbows close to the sides; hands rather above the horse's withers, or pommel of the saddle; and the view directed between his ears. The same writer further advocates the jockey mode, by commenting on the decline of riding-house forms, and the universal preference given to expedition, which, as he says, fully confirm the superior use and propriety of a jockey-seat. Indeed, our riding-schools are now, he continues, considerably reformed from the stiffness of ancient practice in all respects. It was the practice formerly in the schools, and indeed pretty generally upon the road, to ride with the tip of the toe only in the stirrup; as if it were of more consequence to prepare for falling with safety, than to endeavor to sit securely. Those who preserve a partiality for this venerable custom, we would advise to suspend a final judgment, until they have made a few more essays upon a huge cock-tail half-bred, of that kind which 'cannot go, and yet won't stand still,' and will dart from one side of the road to the other, as if he really desired to get rid of his burden. Nor is the ball of the foot a proper rest; chiefly because inconvenient to that erect, or rather almost kneeling, posture, which is required in speedy riding. The riding-house seat is preserved by the balance or equipoise of the body solely; that recommended here by the firm hold of the knee, which is obviously strengthened by the opposite directions of the knee and toe, the one in, the other outward.

634



SECT. XIV. *Of the Feeding of Horses.*

6015. *The feeding of horses generally*, is an important feature in their management. In considering the food for horses, we are apt to locate our notions to the matters around us, without taking into account that every country has its peculiar products. White observes that the best food for horses is hay and oats; and had he added for English horses, it might have been just, but without such notice the assertion is much too confined. In some sterile countries, horses are forced to subsist on dried fish, and even vegetable mould; in Arabia on milk, flesh balls, eggs, broth, &c. In India, where the native grasses are tall, but little nutritious, the better sorts are fed on Indian corn, rice, millet, &c.; and the poorer on rushes, sedge, leaves, &c. In the West Indies on maize, Guinea corn, and sugar-cane tops; and in some instances on the sugar itself, in the form of molasses. In France, Spain, and Italy, besides the grasses, the leaves of limes, vines, the tops of acacia, the seeds of the carob tree, &c. are used.

6016. *The food of British horses* may be divided into herbage, grain, roots, and mixtures. Of herbage, the principal kind is the proper graminæ, eaten either moist, or dried into hay. When eaten moist in their natural state, such a horse is said to *graze*; but when these matters are cut and carried into the stable to a horse, he is said to be *soiled*. Hay is herbage cut during its flowering and seeding processes, which being subjected to the action of the sun and air a proper time, are then collected into large masses called ricks, where a certain degree of fermentation takes place before the matter is fitted to become wholesome or nutritious, or before it receives such alteration as fits it for resisting further decomposition and decay. The judicious management of this fermentative process forms one of the greatest desiderata in hay making. Pursued to a proper extent, the remaining moisture acting on the farinaceous parts, as the seeds, &c., in conjunction with the heat evolved during the process, as it were malts the whole, and sugar is produced. Pushed beyond this, the hay becomes carbonised, and mow burnt; its nutritive properties are lessened, and its noxious qualities increased, it being found in this state to excite diabetes, sweating, and extreme weakness and emaciation. (5756.) The quality of the hay is too little attended to, but which is of very great importance; and more particularly so where little corn but much hay is given. Hay should therefore be of the best, whether meadow, clover, or mixed. Many horses thrive best on clover hay, particularly draught horses. It is very grateful to horses, and it saves much waste of saliva; to sprinkle hay with water, has the same effect, but it should only be done as it is wanted.

6017. *Hay should never be given in large quantities at a time*, horses breathe on it, become disgusted, and then waste it. They also, when it is good, eat too much, and distend their stomachs, and then

become crib-biters. Hay should not be kept in the stable in great quantities, otherwise it becomes impregnated with the volatile alkali of the stable, and is then spoiled. As substitutes for hay, the straw of wheat, barley, oats, and rye are used; but these are much less nutritive, and rather serve to excite mastication by mixing them with other matters, than to be depended on for animalization. On hay, when good, many horses subsist; and when no exertions are required of them they are sufficiently nourished by it.

6018. *The grain used as horse food* is of various kinds, possessing, it is supposed, different degrees of nutriment, according to their different proportions of gluten, sugar, or farinaceous matter. In South Britain, oats are almost exclusively used as horse grain; and which, according to the experiments of Sir Humphrey Davy, as we have seen (4598), contain 748 parts of nutritious matter out of 1000. In wheat, 955 parts of 1000 are nutritious; but wheat is seldom given with us except to racers and hunters, or on extraordinary occasions when great excitement is required, when it is sometimes given in the form of bread. Barley is more frequently given than wheat, and contains 920 parts in 1000 of nutritious particles. Made into malt, where its sugar is evolved, it becomes still more highly nutritious. Barley appears to have been the principal horse food of the ancients.

6019. *The pulse used as horse food*, are the seeds of beans, peas, vetches, &c. Beans are seldom given alone on account of their heating and astringent qualities, but are mixed with straw or hay, cut into chaff, either whole or broken.

6020. *The roots used as horse food*, are such as contain much sugar, but in which the gluten is in small proportion only. Carrots stand deservedly high, on this list. They are favorable to condition, as the skin and hair always look well under their use. They are highly nutritious we know, from the fattening that occurs from them. They also generate good flesh, as we know horses can work on them, and have their wind increased by their use; indeed, so favorable are they to the proper action of the lungs, that a course of carrots will frequently remove the most obstinate coughs. The parsnep has similar properties. Swedish turnips, as having the saccharine particles in abundance, are also found good. Beet-root likewise.

6021. *Mixtures, or mixed food*, is formed of several kinds among agriculturists; and it possesses many advantages, as it can be varied to every taste, and made either cooling as an alternative, or nutritious and stimulating as a tonic. Although it is principally used for waggon, post, and farm horses, it would be better were its use more universal. Of this manger feeding, one of the best is formed from a chaff made of one part best meadow or clover hay, and two parts wheaten straw; to three bushels of this mixture add one of bruised oats. The importance of bruising or flattening the oats is very great. When used whole, the grains are apt to slip between the teeth or the chaff in mastication. In fact, corn when either given alone, or with chaff, would, in most instances, benefit by bruising. To horses under great exertion, the stomach must be, to a certain degree, weakened also; in such cases, by bruising their corn, not only the work of mastication is much of it spared, but that of the stomach also. In old horses with worn teeth, bruised oats are of great consequence. Fast eating horses do not properly masticate more than one half of their corn; much of it remains in the dung so perfectly unaltered, that it will afterwards vegetate; and the celebrated agriculturist Curwen states, that during his residence in India, in a season of scarcity, half famished wretches actually followed the cavalry, and drew their principal subsistence from the unchewed grains of corn extracted from the excrement of the horses. Of this manger food, three, four, five, or six pecks may be given daily, according to size and exertions required; and as but little hay is required, so hard worked horses are enabled to lie down much more, instead of standing on their already fatigued limbs to eat hay.

6022. *Cooked food* is also now much used by practical agriculturists for horses. The articles made use of are potatoes, carrots, turnips or parsneps. To horses with their digestion weakened by hard work, old age, or other causes, food in sufficient quantities, thus already reduced to a pulaceous mass, resembling chyme, without the loss of time, or the waste of saliva, may be very important: for as Curwen very judiciously observes, a horse will consume nearly six hours in eating a stone of hay, whereas he will eat a stone of steamed potatoes in twenty minutes. Horses are observed of themselves to lie down after eating cooked food sooner than other times.

6023. *The quantity of food* to be given to a horse must be regulated by circumstances, the principle of which is the exertions or nature of the work required of him. If this be simply laborious, as drawing of loads, or carrying of weights, all that is requisite is that the food be sufficiently nutritious. The bulk from whence such nutriment is gained is not a matter of import: but if such exertions are to be combined with celerity, as in our racers, hunters, &c.; it is evident that such feeding is best adapted to the end required which combines nutriment without bulk; and which increases the durability by increasing the mental irritability, and thus giving tone and courage. These are found to be better derived from a proportionate allowance of grain or corn, than any other mode of feeding at present known. It remains only to add, that although experience has fully proved this, in all cases where the exertions are extreme; yet it has also led to another evil, by introducing a plan of treating all horses of value alike. Thus most of the more valuable hacknics, the carriage horses of the wealthy, &c., are accustomed to be fed, not as though their exertions were moderate; but as though they were unceasing, to the great injury of themselves, and to the destruction of a vast quantity of valuable corn. To thousands of such horses, at least one third of their hay and corn might be advantageously abstracted.

6024. *Too great a quantity of food* injures not only the community but the horse also. The stomach becomes distended by over-feeding, and it then becomes weak and incapable of a healthy digestion; crib-biting, hiccough, and pursiveness follow; or when the stomach does digest this undue quantity, it generates fulness, which shews itself in inflammations or foulness, appearing in the form of cracks and grease.

6025. *A horse in full work*, of whatever kind, will require, according to his size, a peck of sound oats in twenty-four hours; and when the work is unremitting, as in post horses, even more may be required. Some post horses have an unlimited quantity given them; but this practice is always erroneous. If they eat more, it serves only to distend the stomach unduly, and also to require stronger digestive powers: if they blow on it they leave it, and it is wasted, or a more greedy one swallows it up without mastication; and both stomach, horse, and master, are thereby robbed. The oats should be of the very best, with a thin skin, and should weigh from thirty-eight to forty pounds the bushel. They should also be sweet and free from must, and not kiln-dried. When put into a wide manger and spread about, being first sprinkled with water, their benefit is increased. No horse will require more than eight or ten pounds of hay, in twenty-four hours: from six to eight pounds are usually sufficient. When it can be conveniently done, the quantity of both hay and corn should be divided into four portions. The largest portion both of hay

and corn should be given at night; the next in quantity in the morning; the other two portions at noon, and about four in the afternoon. This however must depend on the work of the horse, and other circumstances.

6026. *Watering of horses* is an important part of their management, and many errors are committed relative to it. It is equally erroneous to debar them from it, as it is to allow them too much; and the former is much the most common evil. In summer, or when from great perspiration, the animal juices are wasted, it generates fevers, and wastes the strength and spirits. All horses prefer soft water, and as nature is unerring, there is no doubt but that it is the most wholesome. As some horses drink quicker than others, it is not a good custom to take riding horses to a pond, unless at night, when the quantity cannot harm them; or when not intended for early work the next morning, as hunting, &c.

6027. *The necessary quantity of water* for a horse should be regulated by circumstances, as the weather, the work, &c. In common cases, a large horse requires rather more than the half of a large stable pail full twice in the day. At night a full pail should be allowed. Horses should never be galloped after drinking; it has destroyed thousands, by gripes, inflammations, and broken wind. This custom also uses horses to expect they are to run away directly they are accidentally watered at any time. Others, expecting they are to be fatigued with a gallop, will avoid drinking at all. The most that should ever be done, is to suffer no horse to drink his fill at a river or pond; but having giving him half what is necessary, walk him ten minutes, and then give him all that is required, and walk him again.

#### SECT. XV. *Of the Stabling and Grooming of Horses.*

6028. *The stabling of horses* is likewise a most important point in their management, the more so as being wholly a deviation from nature; hence, under the most judicious management it is liable to produce some departure from health, and as some times managed, is most hurtful to it. Clothing, dressing or combing, and exercise, are also highly important.

6029. *Every stable should be large, cool, and airy.* It is too common to suppose that warmth is so congenial to horses, that they cannot be kept too hot; but there is reason to suppose that many of the diseases of horses are attributable to the enervating effects of unnatural heat, and of an air breathed and rebreathed over again. Blaine says, Is it not alike repugnant to reason and experience, to expect to keep animals in health, that from stables heated to sixty degrees, and further protected by warm clothing, are first stripped, and then at once exposed to a temperature at the freezing point? If it be argued that habit and exercise render these less hurtful, it will be easy to answer that their original hardihood is lost by confinement and artificial treatment; and that neither does exercise always tend to obviate the effects of this sudden change: for our best carriage horses, and hackneys also, have often to wait hours in roads and streets the convenience of their owners, or the pleasure of the groom.

6030. *The heat of a stable* should be regulated by a thermometer, and the heat shown by it should never exceed 50° of Fahrenheit in winter, or 62° or 63° in summer. To renew the air, the stable should be well ventilated; and which is best done by trunks or tubes passing from the ceiling through the roof.

6031. *A stable should not only be well ventilated, but it should be light also;* and the windows should be so constructed as to admit light and air, without making a current of wind on the bodies of the horses. Darkened stables are very hurtful to the eyes; neither do they, as was formerly supposed at Newmarket, tend to the condition or rest of a horse.

6032. *A stable should have a close ceiling* to keep the dust and dirt from the hay-loft from entering the horses' eyes. It also necessary to prevent the ammoniacal gases from ascending and lodging in the hay. It is preferable that the hay-loft be altogether removed from over the stable; and if a very high ceiling even to the roof were substituted, it would be for the benefit of the horses.

6033. *The form of the rack and manger* should be attended to. Sloping racks are disadvantageous, as encouraging dust in the eyes. They should therefore be upright, and by no means so high as they usually are, by which the head and neck are put injuriously on the stretch. As a proof that this is unpleasant to horses, many of them first pull out all the hay, and then leisurely eat it. The manger should be wide at the bottom, and of a proper height: care should be taken that no splinters are present to endanger the lips, nose, and mouth. The halter reins should, in good stables, be suffered to run within a groove within the manger post, to prevent the rein entangling the legs.

6034. *The stalls of a stable should be wide.* Strains in the back, and sometimes even worse evils, are the consequence of the standings being too narrow. Bails are objectionable from the ease with which horses can kick over them; and also from the quickest feeder getting most food, when several horses stand together bailed.

6035. *The acclivity of the stalls* is a matter of much dispute: when too much raised, as in dealers' stables, they put the back sinews on the stretch, and fatigue horses much. It is more natural that they should be even; or that a very slight slope only be allowed to carry off the urine. The best mode, however, of carrying off the urine, is by means of a small grating to each stall, communicating with a cess pool without doors, which should be closed up, that a current of air may not come through the grating. Such a contrivance will effectually carry off the water, and prevent the volatile alkali of the urine from impregnating the air around. For the same reasons the dung should be removed, if possible, wholly without the stable as soon as dropped; for the exhalations from that are also ammoniacal, and consequently hurtful. To this cause alone, we may attribute many diseases; particularly the great tendency stabled horses have to become affected in the eyes. The pungency of this effluvia is familiar to every one on entering a close stable in the morning, and when the long-soiled litter is removed, it is absolutely unbearable.

6036. *The litter of horses* should be kept dry and sweet, and should be often removed. When it is suffered to remain, under the notion of making better dung, the horse may be ruined; neither does the manure benefit as is supposed; for when it is removed to the dung pit, the close confinement does it more good than the open exposure in the stable, when it parts with its salts, on which its properties as manure partly depend.

6037. *Horses should not stand on litter* during the day, although very generally suffered to do so. Litter is thought to save the shoes and even the feet, by preventing the uneven surface of the stable from hurting them: but it holds the urine; it tenders the feet; it heats them also; and is very apt to encourage swelling at the heels: as we know by removing it, when they immediately go down. A little litter may be strewed behind to obviate the effect of kicking, or the splashing of urine in mares.

6038. *The clothing of horses* is apt to be carried to as erroneous an extent, as the heat of their stables. When horses go out in cold weather, and are intended to have merely a long walking exercise, then clothing is very proper: but it must be evident, that when taken clothed from a stable and exercised briskly so as to produce perspiration, it is erroneous; for not only are the clothes wetted and thus liable to give cold, but the horse is unfitted to go out afterwards with a saddle only. Saddle horses kept in condition stand clothed in a kersey sheet, and girted with a broad roller, with occasionally the addition of a quarter-piece; the breast-plate is sometimes put on when going out to exercise; the hood is used to race-horses only, except in case of sickness. All horses, excepting racers, are best without clothing in the summer season.

6039. *The grooming or dressing of horses* is generally thus practised: having tied

up the horse's head, take a curry-comb, and curry him all over his body, to raise the dandruff or scurf, beginning first at his neck, holding the left cheek of the head-stall in your left hand, and curry him from the setting on of his head, all along his neck, to his shoulder, and so go all over his body to the buttocks, down to his hocks; then change your hands, and curry him before on his breast, and laying your right arm over his back, join your right side to his left, and curry him all under his belly to his chest, and so all over very well, from the knees and shoulders upwards: after that, go to the far side, and do in like manner. Then take a dead horse's tail, or a dusting-cloth of cotton, and strike that dust away which the curry-comb has raised. Then take a round brush, made of bristles, and dress him all over, both head, body, and legs, to the very fetlocks, always cleansing the brush from that dust which it gathers, by rubbing it upon the curry-comb. After that, take a hair-cloth, and rub him again all over very hard, both to take away the loose hairs, and to help to lay his coat; then wash your hands in fair water, and rub him all over with wet hands, as well head as body; for that will cleanse away all those hairs and dust the hair-cloth left. Lastly, take a clean cloth, and rub him all over till he be very dry, for that will make his coat smooth and clean. Then take another hair-cloth (for you should have two, one for his body and another for his legs), and rub all his legs exceedingly well, from the knees and hocks downwards to his very hoof, picking and dressing them very carefully about the fetlocks from gravel and dust, which will lie in the bending of his joints.

6040. *The curry-comb should not be too sharp*, or, at least, not used in a rude and severe manner, so as to be an object of torture and dread, instead of delight and gratification to the horse. It is too often the fate of thin-skinned horses to suffer much from the brutality of heavy-handed and ignorant fellows, who do not recollect that the unhappy animal is suffering, every time he writhes and attempts to escape from the comb or brush, the same tortures that they themselves experience when tickled on the soles of their feet.

6041. *The care of the legs and feet* forms a most important branch of stable discipline. The legs must be kept perfectly dry, and so clean that not a speck of dirt be suffered to lodge in any crevice under the knee or fetlock, or around the coronet, and withal preserved cool and free from stiffness and inflammation. Dirt suffered to form a lodgment, or wet remaining upon the legs in cold weather, will fret the skin, and cause cracked heels, mallenders and sellenders, rat's-tails, crown-scab, and such a train of stable plagues, as may baffle the most vigorous efforts during a whole winter. From want of care, the best flat-legged horses, whatever may be their condition, will soon become greased. Much care should likewise be taken not to irritate and add to the inflammation of the legs, by harsh rubbing; and if they be moderately bandaged with linen or woollen, which every groom knows how to perform neatly, it will contribute to cleanliness and the general end. Some gallopers are apt to crack the skin of their heels in exercise: in that case, supple the skin occasionally with simple ointment, though, in general, warm-water will be a sufficient preservative. Pains and soreness in the shins and shank-bones are often the consequence of exercise over hard ground in very dry seasons, for which there is no better palliative than frequent warm emollient fomentations. It forms a part of the constant attention of a good horse-keeper, to see that the feet of his horses be well-cleansed beneath the shoe with the picker from all small stones or gravel, at every return from abroad. The shoes must be examined, that their ends do not press into the crust, and that the nails be fast, and that the clinches do not rise to cut the horse. In these cases, instant application must be made to the farrier: horses ought by no means to remain in old shoes until the toe is worn away, or the webs become so thin that there is danger of their breaking, unless in case of brittle hoofs, when it is an object to shoe as seldom as possible. Upon the average, good shoes will wear near a month. Steeling the toes is, in general, an useful practice, but less necessary when the best iron is made use of. Where any tendency to dry hoofs exists, the feet should be stopped with equal parts of clay, cow dung, and chamberlye every night, otherwise, twice or three times a week will be sufficient. A still better stopping is made by adding a little tar to the other matters. It is also prudent, when the hoofs have any tendency to hardness and contraction, to water the front part of the stall a little; and also occasionally, or constantly, to hang around the hoofs an apparatus, made by doubling a circle of woollen cloth over a tape, which should be tied around the fetlocks loosely: the two segments of the cloth will then fold around the hoof, and correspond to it in shape. This may be dipped in water, and will be found very convenient in keeping the feet moist and cool. Very brittle hoofs are greatly benefited by brushing them over with a mixture of whale oil and tar. It is considered as beneficial, in general, to take off the shoes of a horse who is necessitated to stand long in the stable, and who does no work, and to substitute tips; the growth of the crust, and the enlargement of the heels being thereby promoted.

6042. *The care of the furniture and trappings* is another part of the duty of a horse-keeper. These are best kept in order by being instantly rubbed clean after use, and placed in a dry situation; by which method, neither oil nor scouring-paper is often found necessary. Great care should be taken to dry the pads of the saddles after journeys, and never to put a hardened and damp saddle upon the horse's back. The same is also necessary with regard to the body-clothes. The pads of the saddles ought to be kept perfectly soft, and free of dirt and sweat; and, after use, should be dried either in the sun or by the fire, and hung in a dry place: the clothes also should be washed much oftener than they generally are, and ever kept perfectly dry, and in a sweet state.

6043. *The exercising of horses* is essentially necessary for their health, as it counteracts the effects of the artificial life we force on them. High feeding, heated stables, and unnatural clothing are, particularly the first, counteracted by proper exercise; and without it, horses become pursive, fat, heavy, and greased; for, when the secretions do not find themselves natural vents by perspiration, &c., they will find themselves artificial ones. Exercise keeps down the fat, and it also hardens and condenses the muscles by drawing their fibres nearer together; it likewise enlarges the muscles. Thus the appearance, as well as the feel, when we handle the flesh of a horse in condition by proper exercise, is totally different from those of one merely full of flesh by fat, &c. Exercise increases the wind by taking up the useless fat, and by accustoming the lungs to expand themselves.

6044. *The quantity of exercise necessary for a horse* must be regulated by a variety of circumstances; as age, constitution, condition, and his ordinary work. A young horse requires more exercise than an old one, but it should be neither very long, nor very fatiguing. Some colts are observed to come out of the breaker's hands with splints and spavins, owing to the severe exercise they have undergone. When

horses are in general work, a little walking exercise in the morning in body cloths, if the condition be very high, or the weather be very cold, is all that is necessary: but, on days when their common work is not expected to occur, a full fed horse should be exercised twice a day, an hour at each time; or, if only once a day, then an hour and a half or two hours' exercise should be given; two-thirds of which ought to be passed in walking; the other should be passed in a moderate trot in the hackney, and divided into galloping and trotting in the hunter. The racer has his regular gallops at stated periods; but the exercise of each should always finish with a walk of sufficient length, to bring the horse in cool, both in person and temper.

#### SECT. XVI. *Of the Management and Working of Horses.*

6045. *The working of horses* includes the racing, hunting, and journeying of saddle horses; and the treatment in harness of coach, waggon, cart, and farm horses.

##### SUBJECT. 1. *Management and Working of Race Horses.*

6046. *In the managing and working of race horses*, three things are to be considered, the preparation of the horse, the conduct of the rider, and the after treatment of the horse. The preparation of a race horse for running a race is not the work of a few days, if there be any great dependence on the success. A month at least is required to harden his muscles in training, by proper food and exercise, and to refine his wind, by clearing his body to that degree of perfection that is attainable by art. It is first necessary to ascertain correctly the present state of the horse, as whether he be low or high in flesh; and in either case, a proper estimate should be formed of the time and means required to bring him into true running condition.

6047. *If a race horse be low in flesh*, it is necessary to judge of the cause of such state, and to act accordingly, the necessary proceedings for which were detailed in treating of condition. (5756.) It is to be remarked, that spices are less to be depended on for this purpose than generous food, as malt mashes; and if any thing of the kind be used, let it be the simple cordial ball. (*Vet. Pharm.* 5899.) Feed frequently, and by little at a time: while he is thus low, let his exercise be walking only, and by no means spare his water, or he will become hide-bound: carefully watch him, that full feeding may not disagree by making his heels swell, or his coat unthrifty; and if such appearances occur, mash him, and begin his scourgings, otherwise abstain from physicking until he is in better health. As he improves in condition, increase his exercise, but not to such a degree as to make him sweat: his food must now be the best oats and beans, with wheat or barley bread; the beans and oats are to be put into a bag, and beaten till the hulls are all off, and then winnowed clean; and the bread, instead of being chipped in the common way, is to have the crust clean off.

6048. *If the horse be in good flesh and spirits* when taken up for his month's preparation, cordials are altogether unnecessary; and the chief business will be to give him good food, and so much exercise as will keep him in wind, without over-sweating, or tiring his spirits. When he takes larger exercise afterwards, towards the end of the month, it will be proper to have some horses in the place to run against him. This will put him upon his mettle, and the beating them will give him spirits. This, however, is to be cautiously observed, that he has not a bloody heat given him for ten days or a fortnight before the plate is to be run for; and that the last heat that is given him the day before the race, must be in his clothes: this will make him run with greatly more vigor when stripped for the race, and feeling the cold wind on every part. In the second week, the horse should have the same food and more exercise; and in the last fortnight he must have dried oats, that have been hulled by beating; after this jockies wet them with the whites of eggs, beaten up, and then laid out in the sun to dry; and when as dry as before, the horse is to have them: this sort of food being considered by them as very light of digestion, and very good for the creature's wind. The beans in this time should be given more sparingly, and the bread should be made of three parts wheat and one part beans, or of wheat and barley in equal parts. If he should become costive under this course, he must then have bran-water to drink, or some ale and whites of eggs beaten together; and keep his body moist. In the last week all mashing is to be omitted, and barley-water given him in its place; and every day, till the day before the race, he should have his fill of hay; then he must have it given him more sparingly, that he may have time to digest it; and in the morning of the race-day, he must have a toast or two of white bread soaked in ale, and the same just before he is led out of the field. This is an excellent method, because the two extremes of fulness and fasting are at this time to be equally avoided; the one heating his wind, and the other occasioning a faintness that may make him lose. After he has had his food, the litter is to be shook up, and the stable kept quiet, that he may be disturbed by nothing till he is taken out to run.

6049. *In the choice of a rider* for winning a race, it is necessary, as far as possible, to select one that is not only expert and able, but honest. He must have a very close seat, his knees being turned close to the saddle skirts, and held firmly there; and the toes turned inwards, so that the spurs may be turned outward to the horse's belly; his left hand governing the horse's mouth, and his right the whip. During the whole time of the race, he must take care to sit firm in the saddle, without waving or standing up in the stirrups. Some jockies fancy the last a becoming seat, but it is certain, that all motions of this kind do really incommode the horse. In spurring the horse, it is not to be done by sticking the calves of the legs close to the horse's sides, as if it were intended to press the wind out of his body; but, on the contrary, the toes are to be turned a little outwards, that the heels being brought in, the spurs may just be brought to touch the sides. A sharp touch of this kind will be of more service toward the quickening of a horse's pace, and will sooner draw blood than one of the common coarse kicks. The expert jockey will never spur his horse until there is great occasion, and then he will avoid striking him under the fore bowels between the shoulders and the girth; this is the tenderest part of a horse, and a touch there is to be reserved for the greatest extremity.

6050. As to *whipping the horse*, it ought always to be done over the shoulder, on the near side, except in very hard running, and on the point of victory; then the horse is to be struck on the flank with a strong jerk; for the skin is the most tender of all there, and most sensible of the lash. When a horse is whipped and spurred, and is at the top of his speed; if he clap his ears in his pole, or whisk his tail, it is a proof that the jockey treats him hard, and then he ought to give him as much comfort as he can by

sawing the snaffle backward and forwards in his mouth, and by that means forcing him to open his mouth, which will give him wind, and be of great service. If there be any high wind stirring in the time of riding, the artful jockey will let his adversary lead, holding hard behind him, till he sees an opportunity of giving a loose; yet, in this case, he must keep so close behind, that the other horse may keep the wind from him; and that he, sitting low, may at once shelter himself under him, and assist the strength of the horse. If the wind happen to be in their back, the expert jockey is to keep directly behind the adversary, that he may have all the advantage of the wind to blow his horse along, as it were, and at the same time intercept it in regard to his adversary.

6051. *When running on level smooth ground*, the jockey is to beat his horse as much as the adversary will give him leave, because the horse is naturally more inclined to spend himself on this ground; on the contrary, on deep earths, he may have more liberty, as he will there spare himself.

6052. *In riding up hill* the horse is always to be favored, by bearing him hard, for fear of running him out of wind; but in running down hill, if the horse's feet and shoulders will bear it, and the rider dares venture his neck, he may have a full loose. If the horse have the heels of the rest, the jockey must always spare him a little, that he may have a reserve of strength to make a push at the last post.

6053. *On the jockey's knowing the nature of the horse that is to run against him*, a great deal depends; for by managing accordingly, great advantages are to be obtained: thus, if the opposite horse is of a hot and fiery disposition, the jockey is either to run just behind him, or cheek by jowl with him, making a noise with the whip, and by that means forcing him on faster than his rider would have him, and consequently, spending him so much the sooner; or else keep him just before him, in such a slow gallop, that he may either overreach, or by treading on the heels of the fore-horse, endanger tumbling over. Whatever be the ground that the adversary's horse runs worst on, the cunning jockey is to ride the most violently over; and by this means it will often happen, that in following he either stumbles or claps on the back sinews. The several corrections of the hand, the whip, and the spur, are also to be observed in the adversary, and in what manner he makes use of them: and when it is perceived by any of the symptoms of holding down the ears, or whisking the tail, or stretching out the nose like a pig, that the horse is almost blown, the business is to keep him on to this speed, and he will be soon thrown out or distanced. If the horse of the opponent looks dull, it is a sign his strength fails him; and if his flanks beat much, it is a sign that his wind begins to fail him, and his strength will soon do so too.

6054. *The after-management of a horse who has run*, includes the treatment between the heats, and the treatment after the race is over. After every heat for a plate, there must be dry straw, and dry clothes, both linen and woollen, ready to rub him down all over, after taking off the sweat with what is called a sweat-knife; that is, a piece of an old sword-blade, or some such thing. After the horse has been well rubbed, he should be chafed all over with cloths wetted in common water, till the time of starting again. When it is certainly known that the horse is good at the bottom, and will stick at the mark, he should be rid every heat to the best of his performance; and the jockey is, as much as possible, to avoid riding at any particular horse, or staying for any, but to ride out the whole heat with the best speed he can. If, on the contrary, he has a fiery horse to ride, and one that is hard to manage, hard-mouthed, and difficult to be held, he is to be started behind the rest of the horses with all imaginable coolness and gentleness; and when he begins to ride at some command, then the jockey is to put up to the other horses; and if they ride at their ease, and are hard held, they are to be drawn on faster; and if it be perceived that their wind begins to rake hot, and they want a sob, the business is to keep them up to that speed; and when they are all come within three quarters of a mile of the post, then is the time to push for it, and use the utmost speed in the creature's power.

6055. *When the race is over*, the horse is immediately to be clothed up and rode home; and immediately on his coming into the stable, the following drink is to be given him: Beat up the yolks of three eggs, and put them into a pint and a half of sound ale, made warm; and let it be given with a horn. After this, he is to be rubbed well down, and the saddle-place rubbed over with warm water and vinegar, and the places where the spurs have touched, with the same; after this he should have a feed of rye-bread, then a good mash, and at some time after these as much hay and oats as he will eat. His legs, after this, should be bathed some time with a mixture of vinegar and water.

#### SUBJECT. 2. *Of the Management and Working of the Hunter.*

6056. *The managing and working of the hunter* includes his preparation for hunting, his condition, and his treatment while taking his regular day's work in the field, whether after buck, fox, or hare hounds.

6057. *The preparation of the hunter* must, like that of the race horse, be commenced by an estimate of his state and condition. If taken fresh from grass, it should be in due time; first, that he may be well prepared; and next, because the grass does not yield much nutriment in the heat of summer. A still better method is to continue to let him run out in the day and graze, having a shed to house himself from heat and rain. He is also to be fed and exercised, nearly as in the common training, for hunting condition. In this way he is sure to be free from cracks, hidebound, or surfeit; and he will prove infinitely more hardy afterwards. It is even the practice with some of the best sportsmen, to allow their horses to run out all the hunting season, unless the weather be very severe; when they are only stabled in a loose place. They are allowed as much corn as they can eat, and are found, if a little rougher in their coats, infinitely superior in hardihood, and exemption from the dangers of cold.

6058. *A hunter taken from grass* or in very low case, should be treated as already fully detailed under condition. (5755.) Great care must be taken that all the alterations in heat of stable, clothing, feeding, &c., are gradually brought about; by which means his flesh will harden gradually, and by using first walking exercise, and increasing it as he advances in flesh and strength, his wind also will become excellent.

6059. *In the physicking of hunters*, particularly when they are low in flesh, much caution is requisite, that it be not over-done. It is the practice with some, and by no means a bad one, to give no physic; but to give more time in the preparation. Others again give mild grass physic, which is an excellent plan, when the weather is fine. (See *physicking*, 5875.)

6060. *The preparation of a hunter in full flesh and not from grass*, depends principally on regular exercise, and the best hard food; physicking him or not, according as he may be suspected to be foul, or as his wind may seem to want mending; but above all, whatever is done, should be done regularly; and

his exercise should be rather long continued than violent. Oats, with beans, are the proper hard food for hunters, taking care that the beans do not constipate the bowels; which must be obviated by bran mixed with the other food, if such should be the case. Bread is not necessary, but for tender delicate horses; but every thing should be of the best.

6061. *The day before a horse is to hunt it is common to treat him somewhat differently, but which is seldom necessary. It is evident he should be well fed, and that not late at night, that he may lie down early. Some feed in the morning, which others avoid; but when it is considered, as has been fully explained (5731.), how ill a horse bears fasting, it will be at once seen, that if very early in the morning, as by five o'clock, he could be fed with a moderate quantity of corn wetted, it would tend to support him through the day.*

6062. *On the return of a horse from hunting, the care bestowed on him should be extreme; as on it depends the immediate recovery of his strength. If he have fasted very long, and particularly if he be disinclined to eat of himself; horn down a pint of ale, with two pints of thick gruel. No prudent sportsman will bring in a horse hot; but if unavoidable accidents prevent this caution, let the horse be again led out for a few minutes, hooded and clothed; but he must have fresh clothes when afterwards dressed. Encourage him to stalc as quickly as possible, after which proceed to hand-rub him all over carefully, placing before him a little of the best hay well sprinkled with water. If he refuse this, offer him three quarts of very clean chilled water. When perfectly cleaned, let his feet be carefully examined, that stubs have not pierced them; or that his shoes have not been forced awry, by over-reaching, or by the suction of clayey ground; or that thorns be not lodged in his knees, hocks, and sinews. After all these matters have been well attended to, remove him from his stall to a loose box, well bedded up. A loose box is invaluable to a hunter; it gives room for stirring to prevent the swelling of the legs; and is better than bandaging when it can be avoided; which gives a disinclination to lie down. If the horse be off his food the next day, give him a cordial ball (*Vet. Pharm.* 5899.) and a malt mash, and afterwards a few cut carrots, which will assist to bring him round more speedily.*

### SUBJECT. 3. *Of the Working and Management of Riding Horses.*

6063. *The working and managing of hackney or riding horses, includes what is required for them as pleasure horses for ordinary airings; and what they require when used for purposes of travelling or long journeyings. It embraces also their stable management in general, with the proper care of horse and stable appointments: all which are usually entrusted to a servant, popularly called a groom, whose qualifications should be, moderate size, light weight, activity and courage, joined with extreme mildness and good temper; and above all, a natural love of horses, by which every thing required is done as a pleasure for the animal he loves, and not as a task for those he is indifferent to.*

6064. *The hackney for gentlemen's airings should be in high condition, because a fine coat is usually thought requisite, and here the groom ought to be diligent that he may keep up this condition by regularity and dressing, more than by heat, clothing, and cordials. Whenever his master does not use his horse, he must not fail to exercise him (but principally by walking) to keep up his condition, and to keep down useless flesh and swellings of the heels. The horse appointments are to be peculiarly bright and clean. The bridle should be billeted and buckled, that the bits may be removed to clean them without soiling the leather, and which cleaning ought not to be done with rough materials, but fine powder and polishing. On the return from exercise, they should be wiped dry and then oiled. Two pair of girths should be used, that a clean pair may always be ready, and the same if saddle cloths are used.*

6065. *The preparation for, and the care of a horse on a journey involve many particulars which should not escape the eye of the master. The first is, Is the horse in hard travelling condition? Next, Do his appointments all fit, and are they in proper order? The bridle for journeying should always be a double curbed one. The snaffle can be ridden with, certainly; but the snaffle cannot do the work of the curb, in staying a horse, in saving him from the ground under stumbling or fatigue; or throwing him on his haunches; or in lightening his mouth. The bridle should not be new, but one to which the horse is accustomed. It is of still more consequence that the saddle be one that the horse has worn before, and that fits him thoroughly. The girths should also be of the best material to prevent accidents; and if the saddle be liable to come forward, however objectionable the appearance, a crupper had better be used. Some days before a long journey is attempted, if the shoes are not in order, shoe the horse; but by no means let it be done as you set off, otherwise having proceeded on the journey a few miles, you find that one foot is pricked, and lameness ensues; or, if this be not the case, one or more shoes pinch, or do not settle to the feet; all which cannot be so well altered as by your own smith.*

6066. *It is always best to begin a long journey by short stages, which accustoms the horse to continued exertion. This is the more particularly necessary if he have not been accustomed to travel thus, or if he be not in the best condition. The distance a horse can perform with ease depends greatly on circumstances. Light carcassed horses, very young ones, and such as are low in flesh, require often baiting, particularly in hot weather: horses in full condition, above their work, and well carcassed, and such as are from seven, or ten, or twelve years old, are better when ridden a stage of fifteen or twenty miles, with a proportionate length of baiting time afterwards, than when baited often, with short stoppages: the state of the weather should also be considered; when it is very hot the stages should be necessarily shorter.*

6067. *To a proper consideration of the baiting times on a journey, the physiology of digestion should be studied. (5727.) Fatigue weakens the stomach; when we ourselves are tired, we seldom have much inclination to eat, and fatigue also prevents activity in the digestive powers. To allay these consequences, ride the horse gently the last two or three miles. If a handful of grass can be got at the road side, it will wonderfully refresh your horse, and not delay you three minutes. In hot weather, let the horse have two or three good downs (gulps), but not more, of water occasionally as you pass a pond; this tends to prevent excessive fatigue. Occasionally walk yourself up hill, which greatly relieves him, and at which time, remove the saddle, by shifting which, only half an inch, you greatly relieve him; and during this time, perhaps he may stale, which also is very refreshing to him. It may be as well, in a flinty country, to take this opportunity of examining that no stones are got into the feet likewise.*

6068. *When a horse is brought into an inn from his journey; if he be very hot, first let him be allowed time to stale; let his saddle be taken off, and with a sweat knife draw the perspiration away; then, with a rug thrown over him, let him be led out and walked in some sheltered place till cool, by which means he will not afterwards break out into a secondary and hurtful sweat: but by no means let an idle oster hang him to dry without the stable. Being now dried, remove him to the stable, where, let some good hay, sprinkled with water, be placed before him: if very thirsty, give three or four quarts of water now, and the remainder in half an hour, and then let him be thoroughly dressed, hand-rubbed, foot-picked, and foot-washed; but by no means let him be ridden into water; or, if this practice is customary, and cannot be avoided, let it be not higher than the knees, and afterwards insist on the legs being rubbed perfectly dry; but good hand-rubbing and light sponging is better than washing. Having thus made him comfortable, proceed to feed him with corn and beans according as he is used.*

6069. *To feed a horse when very hard ridden, or if weakly and tender, it is often found useful to give bread, or bread with ale: if this be also refused, horn down oatmeal and ale, or gruel and ale. It is of*

the utmost consequence if the journey is to be of several days continuance, or if it is to consist of a great distance in one or two days, that the baitings are sufficiently long to allow the horse to digest his food : digestion does not begin in less than an hour, and is not completed in less than three; consequently any bait that is less than two hours, fails of its object; and such a horse rather travels on his former strength than on his renewed strength, and therefore it cannot continue. After a horse is fed he will sometimes lie down; by all means encourage this, and if he is used to do it, get him a retired corner stall for the purpose.

6070. *The night baiting of a journeying horse* should embrace all the foregoing particulars, with the addition of foot stopping; and care that his stable be of the usual temperature to that to which he is accustomed; and that no wind or rain can come to him; give him now a full supply of water; if he has been at all exposed to cold, mash him, or, if his dung be dried by heat, do the same; otherwise, let a good proportion of oats and beans be his supper, with hay, not to blow on half the night, but enough only to afford nutriment.

6071. *When returned home from a journey*; if it has been a severe one, let the horse have his fore shoes taken off, and, if possible, remove him to a loose box, with plenty of litter; but if the stones be rough, or the pavement be uneven, put on tips, or merely loosen the nails of those shoes he has on; keep the feet continually moist by a wet cloth, and stop them at night if the shoes be left on; mash him regularly, and if very much fatigued, or reduced, let him have malt or carrots, and if possible, turn him out an hour or two in the middle of the day to graze: bleeding or physicking are unnecessary, unless the horse shows signs of fear. If the legs be inclined to swell, bathe them with vinegar and chamber-lye, and bandage them up during the day, but not at night, and the horse will soon recover to his former state.

#### SUBJECT. 4. *Of Horses in Curricles and Coaches.*

6072. *In working and managing horses in curricles, two wheel chaises, and similar cases, great feeling and nicety is required, not to overload or overdrive the animal; to see that the weight is duly proportioned between the wheels and horse's back, and that the harness does not pinch; but no directions on this head can be of much use, unless the driver be a humane and considerate person, and one who sets a just value on the services of the noble animal committed to him. In Russia, the drivers of two wheel carriages, as droscheys, sledges, and others, corresponding to our gigs and curricles, have a barbarous custom of teaching the horses to turn round their heads, the one to the left, and the other to the right (fig. 635.), the sight of which is very offensive to a stranger.*



6073. *In working and managing coach horses, the same attention to grooming in all its departments is required as for saddle horses. Coach horses should never be brought into full work before they are five years old: when well fed on hard food they may be worked at an average of thirty miles a day at twice. In general they should not be longer than five or six hours in the yoke at a time. Their principal meals should be in the morning and after their work is over for the day, as the action of trotting fast materially impedes digestion.*

#### SUBJECT. 5. *Working of Cart, Waggon, and Farm Horses.*

6074. *In working and managing cart and waggon horses, a similar attention is requisite as for coach horses, though perhaps in a somewhat less degree, the animal being hardier.*

6075. *The working and managing of farm horses includes the age at which they are put to work, the quantity of work they should perform, and their feeding and general management.*

6076. *The age at which horses are put to full work, in the labors of a farm, is usually when four or five years old, according to the nature of the soil, and the numbers of the team; but they are always understood to be able to pay for their maintenance after they are three years old, by occasional work in ploughing and harrowing. Brown thinks it probable they might be put to work at four years old, were the same attention paid to their breeding and rearing, that is paid to cattle and sheep.*

6077. *The work which a farm horse ought to perform is evidently a question of circumstances, which does not admit of any precise solution, a two-horse plough may, on an average, work about an English acre a day throughout the year; and, in general, according to the nature of the soil, and the labor that has been previously bestowed on it, a pair of horses, in ploughing, may travel daily from ten to fifteen miles, overcoming a degree of resistance equal to from four to ten hundred weight. On a well made road, the same horses will draw about a ton in a two wheeled cart for twenty or twenty-five miles every day; and one of the better sort, in the slow movement of the carrier or waggoner, commonly draws this weight by himself on the best turnpike roads. In some places horses are in the yoke, when the length of the day permits, nine hours, and in others ten hours a day, but for three or four months in winter, only from five to eight hours. In the former season they are allowed to feed and rest two hours from mid-day, and in the latter they*



have a little corn on the field, when working as long as there is day light, but none if they work only five or six hours. (*Sup. Enc. Brit. art. Agr.*)

6078. *The feeding of farm horses* is a subject of great agricultural importance, and has excited considerable discussion among speculative agriculturists, who have generally urged the great expenses attending it as an argument against horses, in favor of oxen. Others, without preferring oxen to horses, have, instead of corn and hay, proposed to feed them on roots, leaves, whins, and even haws from the hedges. The latter have been given in large quantities by West, of Hampshire, and it is said (*Complete Farmer, art. Team.*) were found to answer. That horses as well as men may live on very inferior food is evident; but that either will be able to perform their work under such treatment, as well as if they were properly nourished, is contrary to reason and experience. It is observed by the judicious writer so often quoted, that horses can never perform their labor according to the present courses of husbandry, on carrots, turnips, potatoes, or other roots alone, or as their chief food. They will work and thrive on such food, but they will work as much more, and thrive as much better with oats or beans in addition, as fully to repay the difference in expense. One of the three meals a day, which farm horses usually receive, may consist of roots; and a few of them, every twenty-four hours, are highly conducive to the health of the animals: but we have never had occasion to see any horse work regularly throughout the year, in the way they are usually worked in the best cultivated districts, without an allowance of at least an English peck of oats, or mixed oats and beans, daily, less or more at particular periods, but rather more than this quantity for at least nine months in the year.

6079. *Brown* does not approve of giving much grain to young horses, thinking it expensive, and not so conducive to their health as when they are supported on green food. In the winter and spring months, a few turnips are eminently beneficial to young horses, by keeping their blood in good order, swelling their bone, and hastening their growth. A plentiful supply of grass in summer ought always to be allowed, as their condition through the winter depends greatly upon that circumstance. It is an object deserving of attention, that flesh once gained ought never to be lost, but that every animal whatever should be kept in a progressive state of improvement, and not suffered to take a retrograde course, which afterwards must be made up by extra feeding, or a loss be sustained, in a direct proportion to the degree of retrogradation that has actually occurred.

6080. *The leanness of a farmer's working cattle*, and their reluctant movements under this severe stimulus, clearly marks his unprosperous condition. There are particular operations, indeed, such as turnip-sowing, seeding, fallows, harvest work, &c., which require to be executed with so great dispatch, in our variable climate, that unusual exertions are often indispensable. At these times, it is hardly possible, by the richest food and the most careful treatment, to prevent the animals from losing flesh, sometimes even when their spirit and vigor are not perceptibly impaired. Such labors, however, do not continue long, and should always be followed by a corresponding period of indulgence. It is particularly dangerous and unprofitable, to begin the spring labor with horses worn down by bad treatment during winter. (*Sup. &c.*)

6081. *Donaldson* observes, that the coarse garbage with which farm horses are commonly stuffed, profitably or otherwise, is the real cause of the frequent occurrence among them of blindness, grease, and colic; more particularly the last, which, with care, might be prevented from happening so frequently. The remedy lies in physic, once or twice a-year; either the regular aloetic dose, or salts given in pails of warm water, or sulphur and cream of tartar; one third of the latter mixed in the corn. All horses kept in the stable become, more or less, internally loaded; and it is an error, to suppose cart-horses are not equally benefitted with others by purging physic.

6082. *The cleaning and dressing of farm horses* was formerly very little attended to; but at present its importance to the health of the animal is better understood. *Donaldson* recommends that the heels, legs, bend of the knee, and hock, the twist under the flanks; in short, all parts out of sight, of cart-horses, whilst standing in the house, should be kept perfectly free from dirt and scurf, and the skin supple; the parts more in sight will take care of themselves. In a deep country, it is much the better practice, notwithstanding the prejudice to the contrary, to trim their legs coach-horse fashion. It is now well understood, the editor of *The Farmer's Magazine* observes, that the liberal use of the brush and the curry-comb twice a day; frequent but moderate meals, consisting of a due proportion of succulent joined to more solid food; abundance of fresh litter, and great attention to method and cleanliness, are as indispensable in the stable of a farmer (as far as is consistent with a just regard to economy), as they have always been held to be in the treatment of horses kept for pleasure. Good dressing, with all well-informed and attentive men, is considered to be no less necessary to the thriving of the horses than good feeding; according to a common expression, it is equal to half their food.

6083. *The general management of farm horses in the improved districts of the north*, may be presented as a good example. There, for about four months in summer, horses are fed on pastures; or on clover and rye-grass, and tares cut green, and brought home to the stable or fold-yard; the latter method being by far the most economical and advantageous. For the other eight months, they are kept on the straw of oats, beans, and peas, and on clover and rye-grass hay. As soon as the grass fails towards the end of autumn, they have hay for a few weeks, and when the days become so short as to allow

of no more than from six to eight hours' work, they are very generally fed with different kinds of straw, according to the circumstances of the farm; in the month of March they are again put to hay till the grass is ready for being cut. Throughout all the year they are allowed more or less corn, when constantly worked; and during the time they are on dry fodder, particularly when on straw, they have potatoes, yams, or Swedish turnips, once a day, sometimes boiled barley, and, in a few instances, carrots. A portion of some of these roots is of great importance to the health of horses, when succulent herbage is first exchanged for hay at the end of autumn; and it is no less so towards the latter end of spring, when hay has become sapless, and the labor is usually severe. At these two periods, therefore, it is the practice of all careful managers, to give an ample allowance of some of these roots, even though they should be withheld for a few weeks during the intermediate period.

6084. *The quantity of these different articles of food must depend on the size of the horses, and the labor they perform; and the value upon the prices of different seasons, and, in every season, on the situation of the farm with respect to markets, particularly for hay and roots, which bring a very different price near large towns, and at a few miles distant. It is for these reasons, that the yearly expense of a horse's maintenance has been estimated at almost every sum, from 15*l.* to 40*l.* But it is only necessary to attend to the expense of feeding horses that are capable of performing the labor required of them, under the most correct and spirited management. Such horses are fed with oats, sometimes with beans, three times a day, for about eight months; and twice a day for the other four, when at grass; and, at the rate of eight feeds per bushel, each horse will eat fifteen quarters of oats, or twenty bolls Linlithgow measure in the year. When on hay, he will require about one stone of twenty-two pounds *avoirdupois* daily, and five pounds more if he does not get roots. One English acre of clover and rye-grass, and tares, may be necessary for four months' soiling; and a quarter of an acre of potatoes, yams, or Swedish turnips, during the eight months he is fed with hay or straw. The use of these roots may admit of a small diminution of the quantity of corn in the winter months, or a part of it may be, as it almost always is, of an inferior quality.*

6085. *The expense of feeding a horse throughout the year, may therefore be estimated, in regard to quantities, as follows:*

Oats, fifteen quarters.  
Soiling, one acre of clover and rye-grass, and tares.  
Hay part of October and November, March, April, and  
May, 1½ ton.

Straw for other four months, half the price of hay.  
Potatoes, yams, or Swedish turnips, ½ acre.  
(*Sup.*, &c. art. *Agr.*)

6086. *The extent of land required for a horse's maintenance, supposing the soil to be of a medium quality, may be about five acres; that is, for oats three acres, soiling one, and one more for hay and roots. On rich soils four acres will be sufficient, but on poor soils, and wherever horses are kept at pasture, the produce of six acres and a half, or seven acres, will be consumed by one of them, when worked in the manner already mentioned. The straw of about two acres must be allowed for fodder and litter, the last of which has not been stated above, because, at a distance from towns, what is allowed for litter must at any rate be converted into dung. If sixty acres, therefore, should be assumed as the average extent of land that may be kept in cultivation by two horses, according to the best courses of modern husbandry, the produce of ten acres of this will be required for their maintenance; or, a horse consumes the produce of one acre out of every six which he cultivates, according to a four or six years' course, and sometimes more than one acre out of every five which he ploughs annually. (*General Report of Scotland*, vol. iii. p. 192.)*

## CHAP. II.

*The Ass.* — *Equus Asinus*, L. *Ane*, Fr.; *Esel*, Ger.; *Asno*, Span. and *Asino*, Ital.

6087. *The ass is a native of the mountainous deserts of Tartary, of Arabia, Persia, and other parts of the Asiatic continent; and at present is very generally domesticated throughout most civilized countries. The wild ass feeds chiefly on the most saline or bitter plants of the desert, as the kalis, atriplices, chenopodium, &c.; and also prefers the saltest and most brackish water to that which is fresh. Of this the hunters are aware, and usually station themselves near the ponds to which they resort to drink. Their manners greatly resemble those of the wild horse. They assemble in troops under the conduct of a leader, or centinel; and are extremely shy and vigilant. They will, however, stop in the midst of their course, and even suffer the approach of man, and then dart off with the utmost rapidity. They have been at all times celebrated for their swiftness. Their voice resembles that of the common ass, but is shriller.*

6088. *The excellencies and defects of the common ass* have amply engaged the lively pens of several descriptive writers on the history of animals; and of none with more happy effect than those of the eloquent Buffon, and the ingenious Abbé la Pluche. The ass, in his natural temper, is humble, patient, and quiet, and bears correction with firmness. He is extremely hardy, both with regard to the quantity and quality of his food, contenting himself with the most harsh and disagreeable herbs, which other animals will scarcely touch. In the choice of water he is, however, very nice; drinking only of that which is perfectly clear, and at brooks with which he is acquainted. He is very serviceable to many persons who are not able to buy or keep horses; especially where they live near heaths or commons, the barrenest of which will keep him; being contented with any kind of coarse herbage, such as dry leaves, stalks, thistles, briers, chaff, and any sort of straw. He requires very little looking after, and sustains labor beyond most others. He is seldom or never sick; and endures hunger and thirst longer than most other kinds of animals. The ass may be made use of in husbandry to plough light lands, to carry burdens, to draw in mills, to fetch water, cut chaff, or any other similar purposes. The female (*fig. 636.*) is also useful in many cases for her milk, which is excellent; and she might be of more advantage to the farmer if used, as in foreign countries, for the purpose of breeding of mules. The skin of the ass is extremely hard, and very elastic, and is used for various purposes; such as to cover drums, make shoes, or parchment. It is of the skin of this animal that the Orientals make the fagri, or, as we call it, shagreen. The milk of the ass is the lightest of all milks, and is recommended by medical men, to persons of delicate stomachs; the flesh, and the hair of the tail and mane, are used as those of the horse.

636



6089. *The ass attains his full growth* in three or four years, and may then be put to work. Like the horse he will live to 25 or 30 years; it is said the female lives longer than the male; but, perhaps, this happens from their being often pregnant, and at those times having some care taken of them, instead of which the males are constantly worn out with fatigue and blows. They sleep less than the horse, and do not lie down to sleep, except when they are exceedingly tired. The male ass also lasts much longer than the stallion; the older he is, the more ardent he appears; and, in general, the health of this animal is much better than that of the horse; he is less delicate, and not nearly so subject to maladies. Ophthalmia, which may be reckoned among the indigence of the cultivated horse, is almost unknown to the ass. Contraction of the feet also, is very seldom observed in him.

6090. *The different breeds or races of the ass* are much less known than those of the horse, because in this country they have not been taken the same care of, or followed with the same attention. Travellers inform us, that there are two sorts of asses in Persia, one of which, being slow and heavy, is used for burdens; and the other is kept like horses for the saddle. The latter have smooth hair, carry their heads well, and are much quicker in their motion; but when they ride them they sit nearer the buttocks than when on horseback. They are dressed like horses, and like them are taught to amble; and they cleave their nostrils to give them more room for breathing. According to Dr. Russell, there are two sorts in Syria, one of which are like ours, and the other very large, with remarkably long ears; but both kinds are employed for the purpose of carrying burdens, and sedan chairs. (*fig. 637.*)

637

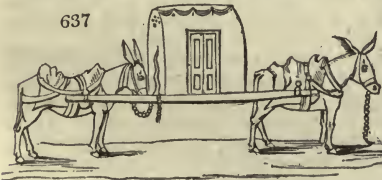

6091. *In breeding from the ass, the same general rules* should be attended to as in the horse breeding. The male ass will procreate at the age of two and a half years, and the female still earlier. The stallion ass should be chosen from the largest and strongest of his species; he must at least be three years old, but should not exceed ten; his legs should be long, his body plump, head long and light, eyes brisk, nostrils and chest large, neck long, loins fleshy, ribs broad, rump flat, tail short, hair shining, soft to the touch, and of a deep grey. Those are reckoned the best shaped that are well squared, have large eyes, wide nostrils, long necks, broad breasts, high shoulders, a great back, short tail, the hair sleek, and of a blackish color.

6092. *The best time of covering* is from the latter end of May to the beginning of June, nor must the female be hard worked whilst with foal, for fear of casting; but the more the male is worked, in moderation, the better he will thrive. She brings forth her foal in about a twelvemonth, but, to preserve a good breed, she should not produce more than one in two years. She should be covered between the months of March and June. The best age to breed at is from three years old to ten. When the foal is cast, it is proper to let it run a year with the dam, and then wean it by tying up and giving it grass, and sometimes milk; and, when it has forgot the teat, it should be turned out into a pasture; but, if it be in winter, it must then be fed at times, till it be able to shift for itself.

6093. *The ass may be broken and trained* at the end of the second year; but should not be worked sooner than the third year. Breaking is easily effected when two years old, or it may be let alone still longer, as till three years. It is easily done by laying small weights on his back, and increasing them by degrees; then set a boy upon him, and so increase the weights as may be proper, till they are sufficiently heavy.

6094. *The age of the ass* is known by his teeth in the same manner as the horse. At two years and a half old, the first middle incisive teeth fall out, and the other on each side soon follow; they are renewed at the same time, and in the same order.

6095. *The anatomy and physiology of the ass* do not differ from those of the horse essen-

tially. The concha cartilages of the ears are, however, considerably more elongated; the spinous processes of the dorsal vertebræ forming the withers are less extensive; and the bones of the extremities in general are less angularly placed; from whence results his inferiority in speed. It is also to the unbending lines of the spine, that his motions are rendered so uneasy to a person placed on the middle of his back. Some specialty occurs in the feet, which, like the horses of arid climes, are small and upright. His laryngeal sonorous sacs and cordæ vocales are not altogether like those of the horse, from whence his aptitude to bray instead of neighing. In the ass there are three laryngeal sacs as in the horse; but instead of a wide opening into them, there is a small round hole, and the anterior sac is a real bag of considerable size. In the horse, there is also, at the commissure of the cordæ vocales, a slight membranous fold not visible in the ass. These organs in the mule are compounded of these forms. Braying appears produced through the mouth, whereas neighing is principally effected by the nose. There is a hollow membranous cavity at the back of the mouth that is greatly assistant to this trumpet-like noise, which is effected by convulsively displacing the velum palati by alternate inspirations and expirations.

6096. *The diseases of the ass*, as far as they are known, bear a general resemblance to those of the horse. As he is more exposed, however, and left to live in a state more approaching to natural, he has few diseases. Those few, however, are less attended to than they ought to be; and it is for the veterinary practitioner to extend to this useful and patient animal the benefit of his art, in common with those of other animals. The ass is seldom or never troubled with vermin, probably from the hardness of its skin.

6097. *The ass is shod* with a narrow web, and with heels projecting beyond the heel of the foot, and slightly turned up, for he seldom overreaches; but much care is required in using small nails, and in very carefully driving them. The hinder shoes differ little from those used for the fore feet.

### CHAP. III.

#### *Of the Mule and Hinny, Hybrids of the Horse and Ass.*

6098. *The Mule* — *Equus Asinus*, var.  $\gamma$ . *Mulus*, L. *Grand Mulet*, Fr.; *Grosser Maulessel*, Ger.; *Mula*, Span. and Ital. — is the hybrid produce of an ass with a mare; having a large clumsy head, long erect ears, a short mane, and a thin tail,

6099. *The Hinny* — *Equus Asinus*, var.  $\delta$ . *Hinnus*, L. *Bardeau* or *Petit Mulet*, Fr.; *Kleiner Maulessel*, Ger.; *Mulo*, Span. and Ital. — is the hybrid produce between the she-ass and a stallion; the head is long and thin, the ears are like those of a horse, the mane is short, and the tail is well filled with hair. The hinny is much less common than the mule, because, being less hardy and useful than the other, he is never cultivated.

6100. *The mule*, commonly so called, is much valued for the saddle, and for drawing carriages in Spain, Portugal, Italy, and the East, and in the warmer parts of America. In those countries where great attention is paid to the breed, it is as tall as the horse, exceedingly well-limbed, but not so handsome, especially about the head and tail. These animals are mostly sterile; some, indeed, have thought that they are altogether incapable of producing their kind; but some few instances have occurred, in which female mules have had foals, and in which even the male has impregnated females both of the ass and horse species, though such instances are exceedingly rare.

6101. *The mules made use of in the southern parts of Europe*, are now brought to an astonishing perfection as well as great size. (fig. 638.)

They are usually black, strong, well-limbed, and large, being mostly bred out of fine Spanish mares.

They are sometimes fifteen or sixteen hands high, and the best of them worth forty or fifty pounds. No creatures are so proper for large burdens, and none so sure-footed. They are much stronger for draught than our horses, and are often as thick-set as our dray-horses, and will travel several months together, with six or eight hundred weight upon their backs. Some think it surprising that these animals are not more propagated here, as they are so much hardier and stronger than horses, less subject to diseases, and capable of living and working to twice the age of a horse. Those that are bred in cold countries are more hardy and fit for labor than those bred in hot; and those which

638



are light made are fitter for riding than horses, as to the walk and

trot; but they are apt to gallop rough; though these do it much less than the short-made ones. The general complaint made against them is, that they kick and are stubborn; but this is owing to neglect in breeding them, for they are as gentle as horses in countries where they are bred with proper care.

6102. *In the breeding of mules*, mares that are of a very large breed and well made should be employed. They should be young, full of life, large barrelled, but small limbed, with a moderate sized head, and a good forehead. It is found of advantage to have the foals from the time of their being dropped often handled, to make them gentle: it prevents their hurting themselves by skittishness and sudden frights; and they are much easier broken at the proper age, and become docile and harmless, having nothing of that viciousness which is so commonly complained of in these animals. They may be broken at three years old, but should never be permitted to do much hard work till four, as they are thus secured from being hurt by hard labor, till they have acquired strength enough to bear it without injury. An expert breeder of these animals found, that feeding them too well while young, though it made them very fat, was far from being any advantage to them; as it was not only incurring a much larger expense than was any way necessary, but also made them wonderfully nice and delicate in their appetites ever after, and also by increasing their weight of flesh, rendered them more subject to strains and hurts in their morning gambols. He therefore contented himself with giving them food enough to prevent their losing flesh, and to keep up their growth without palling their appetites with delicacies, or making them over-fat: he also took care to defend them from the injuries of the weather by allowing them stable room, and good litter to sleep on, besides causing them every day to be well rubbed down with a hard wisp of straw by an active groom. This was scarcely ever omitted, particularly in cold, raw, wet weather, when they were least inclined to exercise themselves. When three years old, mules are proper for use.

6103. *The shoe for the mule* is for the fore foot very similar to that which farriers call the *bar shoe*. It is very wide and large, especially at the toe, where it sometimes projects four inches and upwards beyond the hoof. This excess is given it with a view to enlarge the basis of the foot, which is in general exceedingly narrow in this animal. The shoe for the hind feet is open at the heels, like the horse's shoe: but it is lengthened at the toe, like the preceding one. Mules are however by no means invariably shod in this manner: it is not unusual to shoe them either like horses or asses, as they approach the one or the other in size or work required.

---

#### CHAP. IV.

*Of Neat or Horned Cattle.* — *Bos*, L. *Mammalia Pecora*, L. *Ruminaleæ*, Cuv. *Bêtes à corne*, Fr.; *Vieh*, Ger.; *Ganado*, Span., and *Bestiame*, Ital.

6104. *The neat or horned cattle used in agriculture* are included under two species of *Bos*; the *B. taurus* or Ox, and the *B. bubulus* or Buffalo; the latter less used in Britain than on the continent and in other countries. These animals are more universally used as beasts of draught and burthen than the horse, and have the additional advantage of furnishing excellent food and other valuable products. There is scarcely a country in which the ox or the buffalo is not either indigenous, or naturalized and cultivated; while in many parts of the world, the horse is either wanting, or reserved for the purposes of war or the saddle.

SECT. I. *Of the Ox.* — *Bos Taurus*, L. *Ochs*, Ger.; *Bœuf*, Fr.; *Buey*, Span., and *Bue*, Ital.

6105. *The male ox* is the Bull, *Taureau*, Fr.; *Stier*, Ger.; *Toro*, Span. and Ital.; and the female the Cow, *Vache* Fr.; *Kuh*, Ger.; and *Vaca*, Span. and Ital. The bull and cow inhabit various parts of the world, and, as already observed, are domesticated every where. In most countries, however, they are the mere creatures of soil and climate, the same attention in breeding and rearing that is bestowed on the horse being withheld; the natural habits little restrained or the form improved for the purposes of milking, fattening, or for labor. It is almost exclusively in Britain that this race of animals have been improved so as to present breeds for each of these purposes, far superior to what are to be found in a state of nature or in any other country. Notwithstanding this, however, much certainly remains to be known regarding the nutriment afforded by different kinds of herbage and roots; the quantity of food consumed by different breeds, in proportion as well to their weight at the time, as to the ratio of their increase, and the propriety of employing large or small animals in any given circumstances. Even with regard to the degrees of improvement made by fattening cattle generally, from the consumption of a given weight of roots or herbage, no great accuracy is commonly attempted; machines for weighing the cattle themselves and their food, from time to time, not being yet in general use in any part of Britain. We shall consider the bull family as to his variety, criteria, breeding, rearing, feeding, working, fattening, and milking: the manufacture of milk will be treated of in a succeeding chapter.

#### SUBJECT. 1. *Of the Varieties and Breeds of the Bull.*

6106. *The varieties of the wild ox* are the Bonasus and the Bison (*fig.* 130.); the

first with a long mane, and the last with a gibbous back. They inhabit the woods in Madagascar and many other countries of the east; and the bison is even said to be found in Poland.

6107. The *varieties of the cultivated ox* are the European, Indian, Zebu, Surat, Abyssinian, Madagascar, Tinian, and African. From the European variety have been formed the different breeds cultivated in Britain. They are very numerous, but we shall only notice such as are in most esteem. These different breeds are generally distinguished by the length or flexure of their horns, by the absence of horns, by the districts where they are supposed to have originated, abound, or exist in the greatest purity, or by the name of the breeder.

639



said to afford more cream in proportion to its quantity. They are more varied in their color than any of the other breeds; but, whatever the color be, they have in general a white streak along their back, which the breeders term *finched*, and mostly a white spot on the inside of the hough. (*Culley*, p. 53.) In a general view, this race, notwithstanding the singular efforts that have been made towards its improvement, remains with little alteration; for, excepting in Leicestershire, none of the subvarieties (which differ a little in almost every one of those counties where the long horns prevail) have undergone any radical change or any obvious improvement. The improved breed of Leicestershire (*fig. 640.*), is said to have been formed by Webster, of Cauley near Coventry, in Warwickshire, by means of six cows brought from the banks of the Trent, about the beginning of the present century, which were crossed with bulls from Westmoreland and Lancashire. Bakewell, of Dishley in Leicestershire, afterwards got the lead as a breeder, by selecting from the Cauley stock; and the stocks of several other eminent breeders have been traced to the same source. (*Marshal's Midland Counties*, vol. i. p. 318.)

640

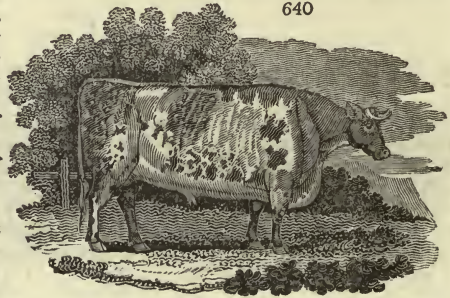

641



6109. The *short-horned*, sometimes called the *Dutch breed*, is known by a variety of names, taken from the districts where they form the principal cattle stock, or where most attention has been paid to their improvement: thus, different families of this race are distinguished by the names of the *Holderness*, the *Teeswater*, the *Yorkshire*, *Durham*, *Northumberland*, and other breeds. The *Teeswater* breed, a variety of short horns, established on the banks of the Tees, at the head of the vale of York, is at present in the highest estimation, and is alleged to be the true Yorkshire short-horned breed. Bulls and cows from this stock, purchased at most extraordinary prices, are spread over all the north of England, and the border counties of Scotland. The bone, head, and neck of these cattle are fine; the hide is very thin; the chine full; the loin broad, and the carcass throughout large and well-fashioned; and the flesh and fatting quality equal, or perhaps superior to those of any other large breed. The short-horns give a greater quantity of milk than any other cattle; a cow usually yielding twenty-four quarts of milk per day, making three firkins of butter during the grass season: their colors are much varied, but they are generally red and white mixed, or what the breeders call *flecked*. The heaviest and largest oxen of the short-

horned breed, when properly fed, victual the East India ships, as they produce the thickest beef, which, by retaining its juices, is the best adapted for such long voyages. Our royal navy should also be victualled from these; but by the jobs made by contractors, and other abuses, it is feared our honest tars are often fed with beef of an inferior quality; however, the coal ships from Newcastle, Shields, Sunderland, &c. are wholly supplied with the beef of these valuable animals. These oxen commonly weigh from sixty to a hundred stone (fourteen pound to the stone), and they have several times been fed to one hundred and twenty, one hundred and thirty, and some particular ones to upwards of one hundred and fifty stone, the four quarters only. (Culley, p. 48.)

6110. In comparing the breeds of long and short-horned cattle, Culley observes, that the long-horns excel in the thickness and firm texture of the hide, in the length and closeness of the hair, in their beef being finer grained, and more mixed and marbled than that of the short-horns, in weighing more in proportion to their size, and in giving richer milk; but they are inferior to the short-horns, in giving a less quantity of milk, in weighing less upon the whole, in affording less tallow when killed, in being generally slower feeders, and in being coarser made and more leathery or bullish in the under side of the neck. In few words, says he, the long-horns excel in the hide, hair, and quality of the beef; the short-horns in the quantity of beef, tallow, and milk. Each breed has long had, and probably may have, its particular advocates; but if he may hazard a conjecture, is it not probable that both kinds may have their particular advantages in different situations? Why not the thick, firm hides, and long close-set hair of the one kind, be a protection and security against those impetuous winds and heavy rains to which the west coast of this island is so subject; while the more regular seasons and mild climate upon the east coast are more suitable to the constitutions of the short-horns.

6111. The middle-horned breeds comprehend in like manner, several local varieties, of which, the most noted are the *Devons*, the *Sussexes*, and the *Herefords*; the two last, according to Culley, being varieties of the first, though of a greater size, the Herefords being the largest. These cattle are the most esteemed of all our breeds for the draught, on account of their activity and hardiness; they do not milk so well as the short-horns, but are not deficient in the valuable property of feeding at an early age, when not employed in labor.

6112. The *Devonshire cattle* (fig. 642.) are of a high red color (if any white spots, they reckon the breed impure, particularly if those spots run one into another), with a light-dun ring round the eye, and the muzzle of the same color, fine in the bone, clean in the neck, horns of a medium length, bent upwards, thin-faced, and fine in the chops, wide in the hips, a tolerable barrel, but rather flat on the sides, tail small, and set on very high; they are thin skinned, and silky in handling, feed at an early age, or arrive at maturity sooner than most other breeds. (Culley, p. 51). Another author observes, that they are a model for all persons who breed oxen for the yoke. (Parkinson on Live Stock, vol. i. p. 112). The weight of the cows is usually from thirty to forty stone, and of the oxen from forty to sixty; the North Devon variety, in particular, from the fineness in the grain of the meat, is held in high estimation in Smithfield. (Dickson's Practical Agriculture, vol. ii. p. 120).

6113. Lawrence says, that the red cattle of North Devon and Somerset are doubtless one of our original breeds, and one of those which has preserved most of its primitive form: the excellence of this form for labor is best proved by the fact, that the fashionable substitution of horses has made no progress in the district of these cattle, by their high repute as feeders, and for the superior excellence of their beef, which has been acknowledged for ages. They are, he says, the speediest working oxen in England, and will trot well in harness; in point of strength, they stand in the fourth or fifth class. They have a greater resemblance to deer than any other breed of neat-cattle. They are rather wide, than middle-horned, as they are sometimes called; some, however, have regular middle horns, that is, neither short nor long, turned upward and backward at the points. As milkers, they are so far inferior to both the long and short-horns, both in quantity and quality of milk, that they are certainly no objects for the regular dairy, however pleasing and convenient they may be in the private family way.

6114. The *Sussex and Herefordshire cattle* (fig. 643.) are of a deep red color, with fine hair and very thin hides; neck and head clean, the face usually white, horns neither long nor short, rather turning up at the points; in general, they are well made in the hind quarters, wide across the hips, rump, and sirloin, but narrow in the chine, tolerably straight along the back, ribs too flat, thin in the thigh, and bone not large. An ox, six years old, when fat, will weigh from sixty to one hundred stone, the fore-quarters generally the heaviest; the oxen are mostly

642



643



worked from three to six years old, sometimes till seven, when they are turned off for feeding. The Hereford cattle are next in size to the Yorkshire short-horns: both this and the Gloucester variety are highly eligible as dairy stock, and the females of the Herefords have been found to fatten better at three years old than any other kind of cattle except the spayed heifers of Norfolk. (*Marshal's Economy of Gloucestershire.*)

6115. *The polled or hornless breeds.* The most numerous and esteemed variety is the Galloway breed (*fig. 644.*), so called from the province of that name, in the south-west of Scotland, where they most abound. The true Galloway bullock "is straight and broad on the back, and nearly level from the head to the rump, broad at the loins, not, however, with hooked bones, or projecting knobs, so that when viewed from above, the whole body appears beautifully rounded; he is long in the quarters, but not broad in the twist; he is deep in the chest, short in the leg, and moderately fine in the bone, clean in the chop and in the neck; his head is of a moderate size, with large rough ears, and full, but not prominent eyes, or heavy eyebrows, so that he has a calm though determined look; his well-proportioned form is clothed with a loose and mellow skin, adorned with long soft glossy hair." (*Galloway Report*, p. 236.) The prevailing color is black or dark-brindled, and, though they are occasionally found of every color, the dark colors are uniformly preferred, from a belief that they are connected with superior hardness of constitution. The Galloways are rather undersized, not very different from the size of the Devons, but as much less than the long horns, as the long horns are less than the short horns. On the best farms, the average weight of bullocks three years and a half old, when the greater part of them are driven to the south, has been stated at about forty stone, *avoirdupois*; some of them, fattened in England, have been brought to nearly one hundred stone.

644

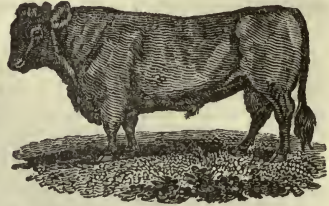

6116. *The general properties of this breed* are well known in almost every part of England, as well as in Scotland. They are sometimes sent from their native pastures directly to Smithfield, a distance of four hundred miles, and sold at once to the butcher; and in spring, they are often shown in Norfolk, immediately after their arrival, in as good condition as, or even better than, when they began their journey; with full feeding, there is perhaps no breed that sooner attains maturity, and their flesh is of the finest quality. Culley was misinformed about the quantity of milk they yield, which, though rich, is by no means abundant; it is alleged not to be more than seventy or eighty years since the Galloways were all horned, and very much the same in external appearance and character, with the breed of black cattle which prevailed over the west of Scotland at that period, and which still abound in perfection, the largest sized ones in Argyleshire, and the smaller in the Isle of Skye; the Galloway cattle, at the time alluded to, were coupled with some hornless bulls, of a sort which do not seem now to be accurately known, but which were then brought from Cumberland, the effects of which crossing were thought to be the general loss of horns in the former, and the enlargement of their size: the continuance of a hornless sort being kept up by selecting only such for breeding, or, perhaps, by other means, as by the practice of eradicating with the knife, the horns in their very young state. (*Coventry on Live Stock*, p. 28.)

6117. *The Suffolk duns*, according to Culley, are nothing more than a variety of the Galloway breed: he supposes them to have originated in the intercourse that has long subsisted between the Scotch drovers of Galloway cattle, and the Suffolk and Norfolk graziers who feed them. The Suffolks are almost all light duns, thus differing from the Galloways, and are considered a very useful kind of little cattle, particularly for the dairy. (*Culley*, p. 66. *Parkinson*, vol. i. p. 116.)

6118. *The cattle of the Highlands of Scotland* are divided into a number of local varieties, some of which differ materially from others, probably owing to a difference in the climate and the quality of the herbage, rather than to their being sprung from races originally distinct, or to any great change effected either by selection or by crossing with other breeds. It is only of late that much attention has been paid to their improvement, in any part of this extensive country; and in the northern and central Highlands the cattle are yet, for the most part, in as rude a state, and under management as defective, as they were some centuries ago. These cattle have almost exclusive possession of all that division of Scotland, including the Hebrides, marked off by a line from the Frith of Clyde on the west, to the Murray Frith on the north, and bending towards the east till it approaches in some places very near to the German ocean. Along the eastern coast, north of the Frith of Forth, the Highland cattle are intermixed with various local breeds, of which they have probably been the basis. There are more or less marked distinctions among the cattle of the different Highland counties; and, in common language, we speak of the Inverness-shire, the Banffshire, &c. cattle, as if they were so many separate breeds; but it is only necessary in this place to notice the two more general varieties, now clearly distinguishable by their form, size, and general properties.

6119. The most valuable of these are the *cattle of the Western Highlands and Isles*,



commonly called the *Argyleshire breed* (fig. 645.), or the breed of the Isle of Skye, one of the islands attached to the county of Argyle. The cattle of the Hebrides are called *kyloes*, a name which is often applied in the south to all the varieties of the Highland cattle, not as a late writer (*Dickson's Practical Agriculture*, vol. ii. p. 1124.) has imagined, from the district in Ayrshire called Kyle, where very few of them are kept, but from their crossing, in their progress to the south, the *kyloes* or *ferries* in the mainland and Western Islands, where these cattle are found in the greatest perfection. (*General Report of Scotland*, vol. iii. p. 26.)



6120. *A bull of the Kyloe breed* should be of a middle size, capable of being fattened to fifty stone avoirdupois. His color should be black or dark brown, or reddish brown, without any white or yellow spots. His head should be rather small, his muzzle fine, his horns equable, not very thick, of a clear green and waxy tinge; his general appearance should combine agility, vivacity, and strength; and his hair should be glossy, thick, and vigorous, indicating a sound constitution and perfect health. For a bull of this description, Macneil, of Colonsay, in 1812, refused 200 guineas; and for one of an inferior sort he actually received 170*l.* sterling. Macdonald, of Staffa, bought one, nine years old, at 100 guineas. (*Report of the Hebrides*, p. 425.)

6121. *The lean weight* of the best stock, from three to four years old, when they are commonly sold to the south, is from twenty-six to thirty stone the four quarters; but when brought to good pastures, they can be easily raised to fifty stone and upwards. There is, perhaps, no other breed whose weight depends so much on feeding; nor any that fattens and grows so much at the same time. They are exceedingly hardy, easily maintained, speedily fattened on pastures where large animals could scarcely subsist; their beef is fine in the grain, and well marbled or intermixed with fat; and their milk is rich, but small in quantity.

6122. The other variety of Highland cattle is the *Norlands*, or *North Highlanders*, including the stocks of the counties of Ross, Cromarty, Sutherland, Caithness, and parts adjacent. Their hides are generally coarse; backs high and narrow; ribs flat; bones large; and legs long and feeble for the weight of the chest; and they are considered very slow feeders. But though this description be but too applicable to the cattle of the greater part of that remote district, considerable improvement has been effected in many parts of it, by crossing with the Skye or Argyle breeds, within the last twenty years.

6123. *The cattle of Orkney and Zeland*, are of a most diminutive size; an ox weighing about sixty pounds a quarter, and a cow forty-five pounds. They are of all colors, and their shapes are generally bad; yet they give a quantity of excellent milk; fatten rapidly when put on good pastures; and, in their own district, are considered strong, hardy, and excellent workers, when well trained to the yoke, and so plentifully fed as to enable them to support labor.

6124. *Of the Fifeshire cattle*, Culley observes, "you would at first imagine them distinct breed, from their upright white horns, being exceedingly light lyered and thin thighed, but I am pretty clear it is only from their being more nearly allied to the kyloes, and consequently less of the coarse kind of short horns in them." (*Culley*, p. 69.) Notwithstanding this opinion, the cattle of the North-eastern counties of Scotland require, for every useful purpose, to be mentioned separately from the Highland herds; and as all of them have a general resemblance, it will only be necessary in this place to notice the Fife cattle in particular. There are various traditions about the origin of this variety. It is said to have been much improved by English cows sent by Henry VII. to his daughter, the consort of James IV. who usually resided at the palace of Falkland, in that county; and as there is some resemblance between the cattle of Fife and Cambridgeshire, they are supposed to have been brought originally from the latter county. Others ascribe the origin of the present breed to bulls and cows sent by James VI. (James I. of England), in payment of the money which his obliging neighbors in Fife are said to have advanced for his equipment, when he went to take possession of the English throne. (*Report of Nairn and Moray*, p. 305.)

6125. *The prevailing color of the Fife cattle* is black, though sometimes spotted or streaked with white, and some of them are altogether grey. The horns are small, white, generally pretty erect, or at least turned up at the points, bending rather forward, and not wide spread like the Lancashire long-horned breed. The bone is small in proportion to the carcass; the limbs clean, but short; and the skin soft. They are wide between the hook-bones; the ribs narrow, wide set, and having a great curvature. They fatten quickly, and fill up well at all the choice points; are hardy, fleet, and travel well, and are excellent for labor, both at plough and cart. A good cow of this breed gives from eighteen to twenty-four quarts of milk per day, yielding from seven to nine pounds of butter, and from ten to twelve pounds of cheese per week (twenty-four ounces to the pound) for some months after calving. (*Fife Report*, p. 251. and 253.)

6126. *The cattle of Aberdeenshire*, the largest of which are said to have been produced by crossing with Fife bulls, have been long highly esteemed in the southern markets. It is observed, that every succeeding generation of them has increased in size, for the last thirty years; and that the native breed has doubled its former weight since

the introduction of turnips. (*Aberdeenshire Report*, p. 468.) The color is commonly black, but there are many of a red and brindled color. They are thinner in the buttock, in proportion to their weight; and deeper in the belly, in proportion to their circumference, than the west Highlanders, and they yield a much larger quantity of milk. Many of them are brought to the south of Scotland, and kept during winter in the straw yards, for which they suit better than smaller cattle, as they are not so impatient of confinement. The ordinary weight of middle-sized oxen, at from three to five years old, is from forty to fifty stone; but after being worked for some time, and thoroughly fattened, they have been known to reach double this weight.

6127. *Of the Welsh cattle*, (fig. 646.) "there seem to be two distinct kinds. The large sort are of a brown color, with some white on the rump and shoulders, denoting a cross from the long-horns, though in shape not the least resembling them. They are long in the legs, stand high according to their weight, are thin in the thigh, and rather narrow in the chine; their horns are white and turned upwards; they are light in flesh, and next to the Devons, well formed for the yoke; have very good hoofs, and walk light and nimble. The other sort are much more valuable; color black, with very little white; of a good useful form, short in the leg, with round deep bodies; the hide is rather thin, with short hair; they have a likely look and a good eye; and the bones, though not very small, are neither large nor clumsy; and the cows are considered good milkers." (*Parkinson on Live Stock*, vol. i. p. 135.)

646

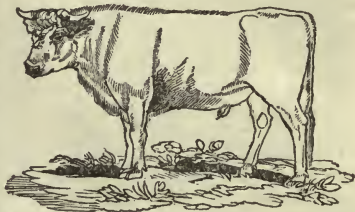

6128. *The Alderney cattle* are to be met with only about the seats of a few great landholders, where they are kept chiefly for the sake of their milk, which is very rich, though small in quantity. This race is considered, by very competent judges, as too delicate and tender, to be propagated to any extent in Britain, at least in its northern parts. Their color is mostly yellow or light red, with white or mottled faces; they have short crumpled horns, are small in size, and very ill shaped; yet they are fine boned in general; and their beef, though high colored, is very well flavored. I have seen, says Culley, some very useful cattle bred from a cross between an Alderney cow and a short horned bull.

6129. *The Irish cattle*, Culley thinks, are a mixed breed between the long-horns and the Welsh or Scotch, but more inclined to the long-horns, though of less weight than those in England.

6130. The last variety of cattle we shall mention is one entirely of luxury, it is the *wild breed*, (fig. 647.) which is found only in the parks of a few great proprietors, who

647

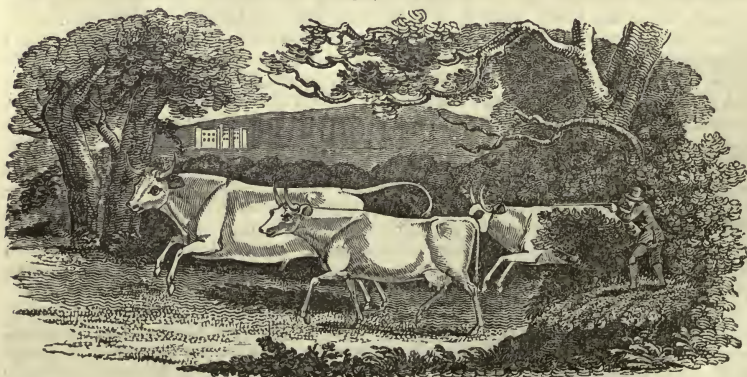

preserve the animals as curious and ornamental, or for the sake of their high-flavored beef. Those kept at Chillingham Castle, in Northumberland, a seat belonging to the Earl of Tankerville, have been very accurately described in the *Northumberland Report*, and in Culley's book on live stock, so often quoted. Their color is invariably of a creamy white; muzzle black; the whole of the inside of the ear, and about one-third of the outside, from the tips downward, red; horns white, with black tips, very fine, and bent upwards; some of the bulls have a thin upright mane, about an inch and a half, or two inches long. The weight of the oxen is from thirty five to forty-five stone,

and the cows from twenty-five to thirty-five stone the four quarters (fourteen pounds to the stone). The beef is finely marbled, and of excellent flavor. From the nature of their pasture, and the frequent agitation they are put into by the curiosity of strangers, it is scarcely to be expected they should get very fat; yet the six years old oxen are generally very good beef, from whence it may be fairly supposed that, in proper situations, they would feed well.

6131. *The habits* of these animals are entirely rude; at the first appearance of any person they set off in full gallop, and, at the distance of about two hundred yards, make a wheel round and come boldly up again, tossing their heads in a menacing manner; on a sudden they make a full stop, at the distance of forty or fifty yards, looking wildly at the object of their surprise, but, upon the least motion being made, they all again turn round, and fly off with equal speed, but not to the same distance, forming a shorter circle, and again returning with a bolder and more threatening aspect than before; they approach much nearer, probably within thirty yards, when they again make another stand, and again fly off: this they do several times, shortening their distance, and advancing nearer and nearer till they come within such a short distance, that most people think it prudent to leave them, not choosing to provoke them farther.

6132. *When the cows calve*, they hide their calves for a week or ten days in some sequestered situation, and go and suckle them two or three times a day. If any person come near the calves, they clap their heads close to the ground, and lie like a hare in form, to hide themselves. This is a proof of their native wildness, and is corroborated by the following circumstance that happened to the writer of this narrative (Bailey, of Chillingham,) who found a hidden calf, two days old, very lean and very weak. On stroking its head it got up, pawed two or three times like an old bull, bellowed very loud, stepped back a few steps, and bolted at his legs with all its force; it then began to paw again, bellowed, stepped back, and bolted as before; but knowing its intention, and stepping aside, it missed him, fell, and was so very weak that it could not rise, though it made several efforts; but it had done enough: the whole herd were alarmed, and, coming to its rescue, obliged him to retire; for the dams will allow no person to touch their calves without attacking them with impetuous ferocity.

6133. *When a calf is intended to be castrated*, the park-keeper marks the place where it is hid, and when the herd are at a distance, takes an assistant with him on horseback; they tie a handkerchief round the calf's mouth to prevent its bellowing, and then perform the operation in the usual way, with as much expedition as possible. When any one happens to be wounded, or is grown weak and feeble through age or sickness, the rest of the herd set upon it and gore it to death. (Culley, p. 73.)

6134. *The mode of killing them* was, perhaps, the only modern remains of the grandeur of ancient hunting. On notice being given that a wild bull would be killed on a certain day, the inhabitants of the neighborhood came mounted and armed with guns, &c., sometimes to the amount of an hundred horse; and four or five hundred foot, who stood upon walls or got into trees, while the horsemen rode off the bull from the rest of the herd, until he stood at bay, when a marksman dismounted and shot. At some of these huntings, twenty or thirty shots have been fired before he was subdued. On such occasions, the bleeding victim grew desperately furious from the smarting of his wounds, and the shouts of savage joy that were echoing from every side. But, from the number of accidents that happened, this dangerous mode has been little practised of late years, the park-keeper alone generally shooting them with a rifled gun at one shot.

#### SUBJECT. 2. *Criteria of Cattle for various objects and purposes.*

6135. *The criteria of a well-made bull*, to whatever breed he belongs, are according to Culley as follows: the head should be rather long, and the muzzle fine; his eyes lively and prominent, his ears long and thin, his horns wide, his neck rising with a gentle curve from the shoulders, and small and fine where it joins the head; the shoulders moderately broad at the top, joining full to his chine or crops and chest backwards, and to the neck-vein forwards; his bosom open, breast broad, and projecting well before his legs; his arms or fore-thighs muscular, and tapering to his knee; his legs strait, clean, and very fine-boned; his chine and chest so full as to leave no hollows behind the shoulders; the plates strong, to keep his belly from sinking below the level of his breast; his back or loin broad, straight, and flat; his ribs rising one above another in such a manner that the last rib shall be rather the highest, leaving only a small space to the hips or hooks, the whole forming a round or barrel-like carcase; his hips should be wide placed, round, or globular, and a little higher than the back; the quarters from the hip to the rump long, and instead of being square, as recommended by some, they should taper gradually from the hips backward, and the turls or pott-bones not in the least protuberant; rumps close to the tail, the tail broad, well haired, and set on so high as to be in the same horizontal line with his back. Bulls should be constantly well fed, and kept in proper enclosures, never being suffered to ride before they are three years old, as when the contrary is the practice, they never attain so perfect a growth. It is observed by Lawrence, that the above description delineates that barrel-shape, which Bakewell supposed most advantageous for all kinds of animals intended to be fed for slaughter, or even used for labor.

6136. *The criteria of excellence in neat cattle in general* are thus given by John Wilkinson of Linton, near Nottingham, an eminent breeder. (*Remarks on Cattle, &c.* 1820.) "The head ought to be rather long, and muzzle fine; the countenance calm and placid, which indicates a disposition to get fat; the horns fine; the neck light, particularly where it joins the head; the breast wide and projecting well before the legs; the shoulders moderately broad at the top, and the joints well in, and when the animal is in good condition, the chine so full as to leave no hollow behind them; the fore flank well filled up, and the girth behind the shoulders deep; the back straight, wide and flat; the ribs broad, and the space between them and the hips small; the flank full and heavy; the belly well kept in, and not sinking low in the middle, or so formed that a cross section of it would resemble an oval, whose two ends are of the same width, and whose

form approaches to that of a circle, or of an ellipsis, whose eccentricity is not great; the whole forming, not a round or barrel like carcass, as some have expressed it, for this would leave a deficiency both in the upper and lower part of the ribs; the hips globular, wide across, and on a level with the back itself; the hind quarters, that is, from the hips to the extremity of the rump, long and straight; the rump points fat, and coming well up to the tail; the twist wide, and the seam in the middle of it so well filled, that the whole may very nearly form a plane, perpendicular to the line of the back; the lower part of the thigh small; the tail broad and fat towards the top, but the lower part thin; the legs straight, clean, and fine boned; and when the animal is in high condition, the skin of a rich and silky appearance. These appear to be the most material points for the formation of true symmetry in cattle: there are others of a minor consideration, which will readily be suggested by attention and experience."

6137. *The criteria of an ox well adapted to labor* differ from the above only in requiring long and strong legs, and broad hardy feet and hoofs.

6138. *The criteria of a beautiful cow*, according to Wilkinson, may be thus expressed.

She's long in her face, she's fine in her horn,  
She'll quickly get fat, without cake or corn,  
She's clear in her jaws, and full in her chine,  
She's heavy in flank, and wide in her loin.

She's broad in her ribs, and long in her rump,  
A straight and flat back, with never a hump;  
She's wide in her hips, and calm in her eyes,  
She's fine in her shoulders, and thin in her thighs.

She's light in her neck, and small in her tail,  
She's wide in her breast, and good at the pail,  
She's fine in her bone, and silky of skin,  
She's a Grazier's without, and a Butcher's within.

6139. *Culley's marks of a good cow* are these: wide horns, a thin head and neck, dewlap large, full breast, broad back, large deep belly; the udder capacious, but not too fleshy; the milk-veins prominent, and the bag tending far behind; teats long and large, buttocks broad and fleshy, tail long and pliable, legs proportionable to the size of the carcass, and the joints short. To these outward marks may be added a gentle disposition, a temper free from any vicious tricks, and perfectly manageable on every occasion. On the other hand, a cow with a thick head and a short neck, prominent back-bone, slender chest, belly tucked up, small udder or a fleshy bag, short teats, and thin buttocks, is to be avoided as totally unfit for the purposes either of the dairy-man, the suckler, or the grazier. The most valuable cows are those which are bred in Yorkshire, Staffordshire, and upon the strong lands in other parts of England, and in Ayrshire in Scotland.

6140. *The criteria of excellence in cattle as derived from color*, is of no importance, and all that can be said is, that white and red cattle are less hardy than the black haired.

6141. *The criteria of age in cattle* is derived from the teeth and horns. At the end of about ten years they shed their first four teeth, which are replaced by others, larger, but not so white; and before five years all the incisive teeth are renewed. These teeth are at first equal, long, and pretty white; but as the animals advance in years, they wear down, become unequal, and black. These animals likewise shed their horns at the end of three years; and they are replaced by other horns, which, like the second teeth, continue. The manner of the growth of these horns is not uniform, nor the shooting of them equal. The first year, that is, the fourth year of the animal's age, two small pointed horns make their appearance, neatly formed, smooth, and towards the head terminated by a kind of button. The following year this button moves from the head, being impelled by a horny cylinder, which lengthening in the same manner, is also terminated by another button, and so on: for the horns continue growing as long as the animal lives. These buttons become annular joints or rings, which are easily distinguished in the horn, and by which the age of the creature may be easily known; counting three years for the point of the horn, and one for each of the joints or rings. The cow continues useful for more than twenty years, but the bull loses his vigor much sooner. It is common with dealers to obliterate these rings, by shaving the horns, in order to conceal the age of the beast.

6142. *The terms applied to different ages* are as follow. A young castrated male, after the first year, is called a stot, stirk, or steer; at five years old an ox. A female, after the first year, is called an heifer, or quey; at five years old, a cow. And afterwards, a castrated female is called a spayed heifer or cow. Certain of the Welsh and Scots cattle, of rather a coarse and sturdy kind, are denominated runts. Bullock is the general term for any full-grown cattle, male or female, fat or lean.

6143. *The natural duration of life with the bull and cow* may be stated at upwards of twenty years, to nearly the end of which the latter is useful with her milk, but the former usually loses his vigor, consequently his use, many years sooner.

SUBJECT. 3. *Of the Breeding of Horned Cattle.*

6144. *The objects to be kept in view* in breeding cattle, are a form, either well adapted to fatten; well adapted for producing milk; or for labor. These three objects have each of them engaged the attention of British agriculturists; but experience has not hitherto justified the expectation that has been entertained of combining all these desirable properties, in an eminent degree, in the same race. That form which indicates the property of yielding the most milk, differs materially from that which we know from experience to be combined with early maturity and the most valuable carcase; and the breeds which are understood to give the greatest weight of meat for the food they consume, and to contain the least proportion of offal, are not those which possess, in the highest degree, the strength and activity required in beasts of labor.

6145. *A disposition to fatten, and a tendency to yield a large quantity of milk, cannot be united.* The form of the animal most remarkable for the first, is very different from that of the other; in place of being flat in the sides, and big in the belly, as all great milkers are, it is high-sided and light-bellied: in a word, the body of the animal well adapted to fatten is barrel-formed, while that of the milker is widest downwards. It is not probable, therefore, that the properties of two breeds of cattle, so opposite in form and general appearance, can ever be united in the same animal.

6146. *The long and short horned breeds* have hitherto been in possession of the best part of the island; but various others, as the Ayrshire, the Galloway cattle, and Kyloes, might be bred with advantage in many situations, so as to be more profitable than either the short-horns or the long-horns. These breeds of cattle, as true quick feeders, and being kindly-fleshed, or excellent eating beef, have established their character in the first market in the island. The Scotch or Kyloes are better adapted to cold, exposed, heathy, mountainous situations, than any other breed we have. Particular breeds are probably best adapted to particular situations; on which ground breeders of cattle should endeavor to find out what breed is the most profitable and best suited to their situations, and to improve that breed to the utmost, rather than to try to unite the particular qualities of two or more distinct breeds by crossing. The latter is a precarious practice, for we generally find the produce inherit the coarseness of both breeds, and rarely attain the good properties which the pure distinct breeds individually possess. In order to have good cattle of any breed, particular regard must be paid in selecting those that are the most complete and perfect in their form, shape, and other qualities, and to breed from them.

6147. *An extraordinary degree of attention* has been paid to the breeding of cattle in England since the time of Bakewell, and some illustrious names might be mentioned in addition to those of professional farmers. Pedigrees of the best cattle have been preserved with no less care, in several places, than those of race-horses, and in the selection of breeders, the properties of the family from which they have descended, are matters of scarcely less importance than the form of the young animals themselves. The extraordinary prices paid for the best bred bulls and cows, show that this attention has not been without its reward.

6148. *The best bulls* are either let out for the season, or cows are brought to them at a certain rate per head. The practice of letting bulls is said to have originated with Bakewell (*Marshal's Midland Counties*, vol. i. p. 334.), who, so far back as 1732, let a bull for one hundred and fifty-two guineas, to be used only four months (*Parkinson*, vol. ii. p. 469.); and five guineas per cow were about that time commonly paid to him and other eminent breeders.

6149. *The age at which bulls should begin to be employed,* and the number of seasons they should be allowed to serve, as well as the age at which the females should begin to breed, are points regarding which practice is by no means uniform. In the midland counties, the bulls are pretty commonly allowed to leap while yearlings, and if good stock-getters are kept on as long as they will do business, perhaps till they are ten or twelve years old. In other places they are employed only three seasons, for the first time at two years old. The females, in many instances, bring their first calf at the age of two years, but more commonly, perhaps, not till they are a year older; and in some of the Highland districts, where, owing to a want of proper nourishment in their infancy, they are later in coming to their full growth, the females do not often become mothers till they are about four years old.

6150. *The period of gestation with cows* has been found, upon an average of a great number of experiments, to be about forty weeks. M. Tessier communicated to the National Institute of France the following observations on this subject: Of 160 cows 14 calved from the 241st to the 266th day; three on the 270th; 50 on the 280th; 68 on from the 280th to the 290th; 20 on the 300th, and five on the 308th. Cows seldom bring more than one calf at a time. When they produce twins, one of them a male and the other a female, the latter, which is called a free martin, is commonly considered to be incapable of procreation. Yet there seems to have been well authenticated instances to the contrary. (*Farmer's Magazine*, vol. vii. p. 462.; and vol. viii. p. 466.)

6151. *The most desirable period for putting cows to the bull* is midsummer, in order that they may be dropped in spring, and have the whole of the grass season before them. Where no regular system is followed, and cows are sent to the bull merely because they are in heat, calves will be dropped at all seasons;

but excepting in those districts where the fattening of calves is an object of importance, it is probably the most advantageous time; as the calves, having all the grass season before them, become sufficiently strong for enduring the change to a less agreeable food in the ensuing winter. A calf newly weaned seldom thrives well during that period, unless it is pampered with better food than usually falls to the share of young animals. By midsummer the cows are readier to take the bull than at any other season, and will bring calves in proper time. If a cow goes till after May before she calves, the calf will be too weak the winter following; the dam will not be so ready to take the bull again, but will often grow barren.

#### SUBJECT. 4. *Of Rearing Horned Cattle.*

6152. *The mode of rearing calves* is various. There can be little doubt but that the best and most natural mode is that of allowing them to suck their dams, at least for some length of time after they are brought forth. The usual method in Yorkshire, and most parts of Scotland, is that of giving them milk to drink, there being few instances where they are allowed to suck. For the first two or three weeks they mostly get milk warm from the cow; but for the next two or three weeks, half the new-milk is withdrawn, and skimmed milk substituted in its stead: and at the end of that period, the new-milk is wholly withdrawn; they are then fed on skimmed milk alone, or sometimes mixed with water, till they are able to support themselves by eating grass, and other food of that sort.

6153. *In Cheshire*, the practice is to allow the calves to suck for the first three weeks. They are then fed on warm new whey, or scalded whey and butter-milk mixed; with the green whey, water is frequently mixed, and either oat-meal, or wheat and bean flour added. A quart of meal or flour is thought sufficient to mix with forty or fifty quarts of liquid. Oat-meal gruel and butter-milk, with an addition of skimmed milk, are also used for the same purpose. Some one of these prepared kinds of food is given night and morning for a few weeks after the calves are put on that diet, but afterwards only once a-day, till they are three months old or more.

6154. *The calves in Gloucestershire* are not allowed to suck above two or three days; they are then fed on skimmed milk, which is previously heated over the fire. When they arrive at such an age as to be able to eat a little, they are allowed split beans or oats, and cut hay, and water is mixed with the milk.

6155. *In Sussex* it is common to allow the calves, either to suck for ten or twelve weeks, or to wean them at the end of three or four, and to give them a liberal allowance of skimmed milk for six or eight weeks longer.

6156. *In Middlesex* the methods pursued for rearing calves, are either by giving them a pailful, containing about a gallon, of milk, warm from the teat of the cow, morning and evening, for eight or ten weeks; or, which is certainly the most agreeable to nature, and, therefore, to be preferred to any other that can be adopted, to allow the calf to suck its dam, as is sometimes done in the county of Sussex, and generally in Wigtownshire.

6157. *According to Marshal* the best method is this: The calves suck a week or a fortnight, according to their strength (a good rule); new milk in the pail, a few meals; next, new milk and skim-milk mixed, a few meals more; then, skim-milk alone; or porridge, made with milk, water, ground oats, &c., and sometimes oil-cake, until cheese-making commences; after which, whey porridge, or sweet whey, in the field; being careful to house them in the night, until warm weather be confirmed. (*Midland Counties*, vol. i. p. 338.) This method of suckling is not, however, free from objection, and, in the ordinary practice of rearing calves, it is held to be a preferable plan to begin at once to learn them to drink from a pail. The calf that is fed from the teat must depend upon the milk of its dam, however scanty or irregular it may be; whereas, when fed from a dish, the quantity can be regulated according to its age; and various substitutes may be resorted to, by which a great part of the milk is saved for other purposes, or a greater number of calves reared upon the same quantity. (*General Report of Scotland*, vol. iii. p. 51.) Yet it would seem to be a good practice to allow calves to suck for a few days at first, if there was no inconvenience to be apprehended both to themselves and their dams, from the separation afterwards.

6158. *When fed from the pail*, the average allowance to a calf is about two English wine gallons of milk daily, for twelve or thirteen weeks; at first fresh milk as it is drawn from the cow, and afterwards skim-milk. But after it is three or four weeks old, a great variety of substitutes for milk are used in different places, of which linseed oil-cake, meal, and turnips, are the most common.

6159. *Where calves are reared with skim-milk*, it should be boiled, and suffered to stand until it cools to the temperature of that first given by the cow, or a trifling degree more warm, and in that state be given to the calf. Milk is frequently given to calves warm only; but that method will not succeed so well as boiling it. If the milk be given over-cold, it will cause the calf to skit or purge. When this is the case, put two or three spoonfuls of rennet in the milk, and it will soon stop the looseness. If, on the contrary, the calf is bound, bacon-broth is a very good and safe thing to put into the milk. One gallon of milk per day will keep a calf well till it be thirteen weeks old. A calf may then be supported without milk, by giving it hay, and a little wheat-bran, once a-day, with about a pint of oats. The oats will be found of great service as soon as the calf is capable of eating them. The bran and oats should be given about mid-day: the milk in portions, at eight o'clock in the morning, and four in the afternoon. But whatever hours are chosen to set apart for feeding the calf, it is best to adhere to the particular times, as regularity is of more consequence than many people think. If the calf goes but an hour or two beyond his usual time of feeding, he will find himself uneasy, and pine for food. It is always to be understood, that calves reared in this manner are to be enticed to eat hay as early as possible; and the best way of doing this is to give them the sweetest hay that can be got, and but little at a time. Turnips or potatoes are very good food, as soon as they can eat them; and they are best cut small, and mixed with the hay, oats, bran, and such articles. It may be observed, that it is not absolutely necessary to give milk to calves after they are one month old; and to wean them gradually, two quarts of milk, with the addition of linseed boiled in water to make a gruel, and given together, will answer the purpose, until, by diminishing the milk gradually, the calf will soon do entirely without. Hay-tea will answer the purpose, with the like addition of two quarts of milk; but is not so nutritious as linseed. It is a good method of making this, to put such a proportion of hay as will be necessary into a tub, then to pour on a sufficient quantity of boiling water, covering up the vessel, and letting the water remain long enough to extract the virtues of the hay. When bacon or pork is boiled, it is a good way to preserve the liquor or broth, and mix it with milk for the calves.

6160. *In summer, calves may sometimes be reared on whey only*; but when reared in winter, they must be fed with hay; and clover-hay is probably the best of any for this use. Calves may also be raised with porridge of different kinds, without any mixture of milk. It is sometimes a good and convenient plan, the author of the *New Farmer's Calendar* says, to bring up calves under a step-mother; an old cow, with a tolerable stock of milk, will suckle two calves, or more, either turned off with her, or at home, keeping them in good condition, until they are old enough to shift: they ought to suck the first of their mother's milk, for two or three days, although many are weaned without ever being suffered to suck at all. Calves, whether rearing or fattening, should also always suck before milking, the cow being milked

afterwards, as the first and thinnest of the milk is sufficiently rich. Old milk will, perhaps, scour a very young calf; but the effect will go off without any ill consequences. He observes, that the Duke of Northumberland's recipe is to take one gallon of skimmed milk, and to about a pint of it add half an ounce of common treacle, stirring it until it is well mixed; then to take one ounce of linseed oil-cake, finely pulverised, and with the hand let it fall gradually, in very small quantities, into the milk, stirring it, in the mean time, with a spoon or ladle, until it be thoroughly incorporated; then let the mixture be put into the other part of the milk, and the whole be made nearly as warm as new milk, when it is first taken from the cow; and in that state it is fit for use. The quantity of oil-cake powder may, from time to time, be increased as occasion may require, and as the calf becomes inured to the flavor of it. And Crook's method is to make a jelly of one quart of linseed, boiled ten minutes in six quarts of water, which jelly is afterwards mixed with a small quantity of the best hay-tea; on this he rears many calves without milk; thinks many calves are annually lost by artificial rearing, and more brought up with poor and weak constitutions.

6161. *When calves are dropped during the grass season*, Donaldson observes, they should be put into some small home-close of sweet rich pasture, after that they are eight or ten days old, not only for the sake of exercise, but also that they may the sooner take to the eating of grass. When they happen to be dropped during winter, or before the return of the grass-season, a little short soft hay or straw, or sliced turnips, should be laid in the trough or stall before them.

6162. *Castration* is performed both on male and female calves, when neither are intended for procreation. On cow calves, however, it is often omitted. But in Norfolk no distinction is made as to sex; males and females are equally objects of rearing, and are both occasionally subject to castration, it being a prevailing custom to spay all heifers intended to be fatted at three years old; but such as are intended to be finished at two-years old, are, it is believed, pretty generally left "open;" as are, of course, those intended for the dairy. There are two reasons for this practice: they are prevented from taking the bull too early, and thereby frustrating the main intention; and by this precaution may lie more quietly, and are kept from roving at the time of fattening. This may be one reason why spayed heifers are thought to fatten more kindly at three years old, and to be better fleshed, than open heifers.

6163. *The time of performing the operation of castration* in horned cattle, as in all kinds of live stock, is while the animals are yet very young, and just so strong as to endure this severe operation, without any great danger of its proving fatal. The males, accordingly, are cut commonly when about a month old, and the females at the age of from one to three months; but in Galloway, where more heifers are spayed than perhaps in all the island besides, this is seldom done till they are about a year old.

6164. *The best time for rearing calves* is the spring; but that operation must depend in some degree on the time when the calf was dropped. Such as are weaned during autumn or winter, however, seldom do any good. At the season when the calf is weaned from the teat, it ought to be turned abroad, in the day-time, into a small close or orchard near the yard, where there is a good bite of grass, which may be expected at the time of the year when the weaning-calves are of this age; and, as there will generally be more than one calf weaned in a season, they will each be company for the other, and become in a short time reconciled to their situation. It is to be observed, that this pasture should be at some distance from that whereon the dams are turned, and that there be neither ponds nor ditches, nor any annoyance which might endanger the lives of these youthful animals; and, in order to habituate them still more to their pasture, milk-pottage should be carried to them at each of their feeding hours. For the first month or six weeks, the calves ought every night to be brought out of the meadow, and lodged in the pens; but, after this time, they may be left in the pasture as well in the night-season as in the day; and at this time their food may be lowered by degrees, till it be at length reduced to simple water only; for, when the calves get to the age of twelve or fourteen weeks, they will no longer require the aid of this sustenance, but will be able to satisfy their appetites by grass. Care, however, must be taken throughout the summer that they be frequently shifted from one pasture to another, in order that they may be kept up in good flesh, and enabled to grow away with the utmost celerity. At Michaelmas, or soon after, the calves should be taken into the yard; and if they were allowed the indulgence of a small close to themselves it would be still better.

6165. *The treatment of young cattle*, from the time they are separated from their dams, or able to subsist on the common food of the other stock, must entirely depend upon the circumstances of the farm on which they are reared. In summer, their pasture is often coarse, but abundant; and in winter, all good breeders give them an allowance of succulent food along with their dry fodder. The first winter they have hay and turnips; the following summer coarse pasture; the second winter straw in the fold-yard, and a few turnips once a day, in an adjoining field, just sufficient to prevent the straw from binding them too much; the next summer tolerably good pasture; and the third winter as many turnips as they can eat, and in every respect treated as fattening cattle. (Culley, p. 47.)

6166. *The method of managing young cattle* during the first winter is, according to Donaldson, pretty generally the same in every part of the island. They are almost always housed: sometimes bound up to the stall; but more frequently allowed to remain at freedom. The way of feeding them in England is chiefly with hay, or hay and straw mixed; and in Scotland, sometimes hay, but more frequently straw and turnips. They are mostly turned out on some of the inferior pastures on the farm the following summer, and maintained the second winter on straw in the straw-yard, or in houses or sheds erected for the purpose. Some farmers in the more northern parts of the kingdom, from being situated at a distance from any market at which they can dispose of stall-fed beef, very frequently give a considerable part of their turnip-crop to their young cattle. This is, he thinks, an excellent practice; and one that ought to be followed, even by those who, from being better situated in regard to markets, can adopt other methods of using turnips to advantage. The benefit of green winter food for live-stock is so great, that there is probably, he says, no way in which turnips can be used, by which the farm or the farmer would reap greater benefit, than by giving the young cattle a daily allowance during the first two or three winters.

#### SUBJECT. 5. *Of Fattening Calves by Suckling.*

6167. *The most advantageous stock for suckling calves* for the butcher, is that sort of cow which gives the greatest quantity of milk, richness of quality being not so great an object, or so well adapted to the desired purpose. The Holderness cows are to be preferred in this view; not, however, to suckle calves of the same, but of a smaller breed; perhaps Devon

calves surpass all others as sucklers, whether for quickness of proof, or beauty of the veal; they are not, however, to be procured, but in or near their own country.

6168. *The method most commonly employed in fattening calves is, to allow them to suck; as by this method the object is probably not only sooner, but more effectually attained than by any other means.* The period which is necessary for fattening calves in this way must be different, according to circumstances, but it is generally from seven to nine weeks; however, in the dairy districts, where milk is considered a valuable article, scarcely half that time is allowed. There is another method, which is, to give them the milk to drink; and when that is done, it is given them morning and evening warm from the cow, and the quantity increased according to their age and strength. In whatever way they may be managed, they should be kept in pens in a close-house, and well littered. The author of the *Synopsis of Husbandry* observes, that as it is necessary that the calves should lie always quiet, in order that they may indulge in sleep at those times when they are not employed in sucking; it seems proper that the cow-house should be situated in the most retired part of the yard, and that the pens should be kept as dark as possible. But notwithstanding this caution, the calves should by no means be suffered to lie too hot in the summer-time, which would be apt to produce a sickness amongst them. To admit, therefore, an occasional draught of fresh air, let a window be cut in each pen, with shutters adapted to the same, and let these windows be opened whenever the closeness of the atmosphere indicates it to be necessary. In the summer season, they should rarely, if ever, be closely shut; and when it is required, the stream of air may be increased by opening the cow-house door at the opposite end of the building. Each calf should have a collar round his neck, with which the attendant may direct him in his suckling, but should never be fastened up in the pen. It is necessary that the pens be kept constantly well littered with the cleanest wheat-straw, a proportion of which should be thrown into them every day; cleanliness being a most essential article in the fattening of every animal, and not more necessary to any than the calf, which, but for this precaution, would in a short time demonstrate the ill effects of lying on his accumulated dung, which of all other animals is the most offensive, and of a quality highly septic. As the calves are yeaned, they are to be taken into the pens, and suckled on their own dams, which, at first, will yield a far greater quantity of milk than is necessary for their offspring, so that another calf may be suckled thereon; or the cow may be milked, and the cream be reserved for butter, or applied to any other use that the owner may think proper. As the calf increases in size, it will require a larger quantity of milk: but whilst calves are young, one good cow will yield a noble supply for two; and when the whole produce is demanded for one calf, another new milch cow should be provided, and these two cows will abundantly supply the three calves with milk till the oldest is fit for the butcher; after which, if necessary, a fresh suckler may be brought in, and the business be carried on progressively by keeping the house constantly supplied with calves, so that the whole milk may be sucked, as the fattening of calves by suckling and the dairy cannot be conveniently united.

6169. *Young calves, when permitted to suck their fill, are often seized with a lax or scouring.* To prevent which, the calves for the first fortnight or three weeks may be stinted in their allowance; and at the same time due regard should be taken that they do not pine or decrease in flesh for want of milk. But after this age they should be allowed to suck as long as they choose, and every means ought to be made use of to increase their appetite, and render them more eager after their food. Chalk may be given for this purpose, as well as for giving to the flesh a delicate whiteness. An excellent astringent remedy has been already given. (5883.) Salt sprinkled in the trough will likewise act as a stimulus to the appetite; besides which, it is a common practice with some people to cram their calves with balls compounded of flour, pounded chalk, and milk, with the addition of a small quantity of common gin. Of these balls they give two, about the size of a walnut, once a-day, or oftener, to each calf. These balls being very nutritious, in some degree supply the place of milk, and at the same time the spirituous mixture operates on the creatures as a soporific, and thus, by composing them to sleep, increases their disposition to fatten: but where milk can be had in sufficient abundance, it is never worth while to have recourse to these factitious aids. When the demands of the calf, however, are beyond the ability of the cow, these balls come seasonably to their relief. In order that the calves may be provided with sufficient store of milk, the pastures should still be changed, whenever the cows are found to be deficient in this particular: and in the winter-time, such food as is of a succulent nature, as grains, turnips, &c. should be always at hand to supply the want of grass: and these, with a due allowance of the sweetest hay, should be their constant aliment during the time that the cows are confined to the yard.

6170. *The prices of suckling calves vary according to the goodness of the young animal, and the time of year wherein the purchase is made.* In general, sucklers fetch the largest price in summer, when veal sells the cheapest; and the reason of this arises from the smaller number to be met with at that time than



in the spring. When calves are slaughtered at six weeks or two months old, the veal is seldom of a good color; neither has the flesh of these young calves a taste equal to that where the animal has been suffered to live a few weeks longer. To attain both these ends of color and flavor, it is necessary that the calves should be maintained with plenty of milk, and regulated under such management as before directed, till they arrive at the age of eight or ten weeks, according to the season of the year, the more or less kindly state of the calf, the particular demand of the markets, or other eventual circumstances. In the summer season, it may be proper to dispose of them at an earlier period than in the winter; not only on account of their growing away with greater celerity in warm weather, but likewise because of the increased demand for small veal, which is then most saleable. During the last three or four weeks, blood should frequently be drawn from the calf, which will be a likely means towards rendering the veal of a color delicately white; a circumstance so much attended to by the butcher, that he will commonly depreciate such calves, which, from the appearance of their eyes, are likely to die black, as they term it, though in other respects not to be despised.

6171. *Such calves as are suckled on their own dams* will, generally speaking, fatten in a shorter time than those which are afterwards bought in to supply their places. The first obvious reason for this difference in their favor is, their not having been removed from the place where they were first dropped, and having always continued to suck the milk of their parent animal, which must in all reason be supposed of a more nutritious quality to them than that of any other cow. Secondly, the cow having so lately calved, the aliment nourishes and fattens in a higher degree than when the animal becomes stale-milched. Cow-calves are observed to fatten more kindly than the male or bull-calves; and these last are much more coarse-grained, and their flesh less delicate in taste than the former. Calves of the largest size are fattened in Essex, where the business of suckling seems to be better understood, and more properly conducted, than in any other county, and where the farmer keeps the calves to a greater age than in any other part of the kingdom.

6172. *Marshal* is clearly of opinion, that to suckle calves in general after they are ten weeks old is bad management; for his account in this respect is uniform, those of nine or ten having paid as much a week as those of twelve or thirteen; and although a calf of six weeks old may suck nearly as much milk as a calf of twelve weeks old, yet the first month or five weeks the quantity is considerably less, and this advantage of their infancy is doubly as valuable to nine as it is to twelve weeks. There can be no doubt but that the profit of this system of fattening depends materially upon the quickness of return.

6173. *In some districts*, barley-meal, linseed boiled into a kind of jelly, and such-like articles, are given to calves in the course of fattening; but the methods above described are greatly superior, although it must be allowed that they may sometimes be considerably more expensive.

#### SUBJECT 6. *Of Fattening Horned Cattle.*

6174. *The fattening of cattle demands considerable and constant attention*, and the grand object is to fatten quickly. An animal when in a state of rearing may be considered as a vessel open at both ends, in which the supply and the waste being nearly equal it can never be filled: fattening an animal may be considered as an attempt to fill the vessel, and which can only be done by excess of supply. The waste being the same as before, this excess must be great; if it is not so, the vessel may be rendered fuller than before without ever becoming full. An important hint might be taken from this simile by many farmers, who know little of the difference between feeding and fattening. We have known cattle, sheep, and swine, kept for months and fed, with a view to fattening them, without their gaining a pound of meat.

6175. *The food on which cattle are fatted*, is grass in summer, commonly on pastures, but in a few instances on herbage cut and consumed in feeding-houses or fold-yards; and in winter, by far the greater number are fatted on turnips, along with hay or straw, oil-cake; carrots, potatoes, and other articles of food, are used occasionally, and in particular districts; oil-cake chiefly for feeding the larger animals; but few, comparatively, are fatted on any of these without the addition of turnips, of one or other of the varieties formerly mentioned. (4879.) A considerable number of cattle are also fatted on the offals of distilleries, when distilling from corn; a source of supply, the frequent interruption of which has been much felt in those situations where the soil does not permit the extensive cultivation of turnips. It is seldom or never the practice of the best managers to fatten cattle with roots or other winter food on the field, during that season; but to confine them to houses or fold-yards, where they are well littered, regularly fed, not liable to be disturbed, and sheltered from the inclemency of the weather, and where the manure they make is an object of very considerable importance, and of much greater value than if it were dropped at random over a whole field.

6176. *The age at which cattle are fatted* depends upon the manner in which they have been reared; upon the properties of the breed in regard to a propensity to fatten earlier or later in life; and on the circumstances of their being employed in breeding, in labor, for the dairy, or reared solely for the butcher. In the latter case, the most improved breeds are fit for the shambles when about three years old, and very few of any large breed are kept more than a year longer. As to cows and working oxen, the age of fattening must necessarily be more indefinite: in most instances the latter are put up to feed after working three years, or in the seventh or eighth year of their age. In general, it may be said, that the small breeds of cattle are fattened on pastures, though sometimes

finished off on a few weeks' turnips; and that large cattle, at least in the north, are chiefly fattened in stalls or fold-yards, by means of turnips, and the other articles before mentioned.

6177. *Stall-feeding* is the most common, and, when judiciously conducted, probably the most eligible method, in regard to the cattle themselves, the economy of food, and the expense of farm-buildings. The small shed and fold-yard, called a *hammel* (2657.), are used only for the larger breeds; but they do not seem well calculated for an extensive system of fattening by those who do not breed, but purchase stock every year from different parts. (*Sup. E. Brit. art. Agr.*)

6178. *The two great points in feeding animals, to proof*, according to the author of the *Farmer's Calendar*, are, regularity, and a particular care of the weaker individuals. On this last account there ought ever to be plenty of trough or rack-room, that too many may not feed together; in which very common case the weaker are not only trampled down by the stronger, but they are worried, and become cowed and spiritless, than which there cannot be a more unfavorable state for thrift; beside, these are ever compelled to shift with the worst part of the meat. This domineering spirit is so remarkably prevalent amongst horned cattle, that he has a hundred times observed the master-beasts running from crib to crib, and absolutely neglecting their own provender for the sake of driving the inferior from theirs. This is, much oftener than suspected, the chief reason of that difference so visible in a lot of beasts, after a winter's keep. It is likewise, he says, a very common and very shameful sight, in a dairy of cows, to see several of them gored and wounded in a dozen places, merely from the inattention of the owner, and the neglect of tipping the horns of those that butt. The weaker animals should be drawn and fed apart; and in crib-feeding in the yard, it is a good method to tie up the master-beasts at their meals.

6179. *Fattening cattle*, Donaldson observes, are usually put to grass in May or June, according to the season and situation in regard to climate. The period necessary for fitting an ox for the butcher depends on several circumstances; as the condition he was in when put to grass, the nature of the pasture, and many others; but, in ordinary cases, an ox will be completely fattened in three months. There is, he says, one method of fattening, connected with the grazing system, that the farmers in England are enabled, from the superior excellence of the climate, to adopt with success, which can never be attempted with propriety in Scotland. It is very common, at the close of the grass-season, when the fattening stock happen not to be fully in condition for the butcher, to render them so, by giving them hay two or three times a day in the field, or in hovels erected for the purpose, into which they have access at pleasure.

6180. *When turnips are employed for the purpose of fattening cattle*, especially if they are put up to the stalls in proper condition, which, considering the season of the year (November), must, with ordinary attention, always be the case, from ten to thirteen weeks is fully sufficient to render them fit for market.

6181. *The fattening of cattle with grains* may, in some respects, be considered as a branch of the distillery business; but yet there are some instances wherein those who cultivate farms practise it with a double view — of obtaining a profit on the sale of cattle, and the acquisition of a valuable treasure of useful manure. Adam, the renter of the farm of Mount Nod, near Streatham, in the county of Surrey, erected a very complete building, for the purpose chiefly of fattening cattle on grains. In this building might sometimes be seen several hundred head of cattle.

6182. *The method of fattening cattle with oil-cake*, corn, cut chaff, &c. is practised in many of the English counties, with a degree of success sufficient to warrant farmers in other parts of the island to follow the same practice. The cattle are commonly put up to fatten at the end of the grass season. The usual allowance of oil cake, after it is broken in a large mortar, or, in the fruit districts in a cyder-mill, is about half a peck per day, which is given, one half in the morning, and the other in the evening; to which is added hay, and in some cases ground corn, that is, oats or barley of inferior quality, and cut straw — provincially “chaff.” As bullocks fattened in this manner get regularly five, and sometimes six meals a day, it is sufficiently evident that, although it may be upon the whole an expensive mode of fattening, yet it must be both expeditious and effectual.

#### SUBSECT. 7. *Of the Management of Cows kept for the Dairy.*

6183. *Milch cows* are kept for the manufacture of butter and cheese, for the suckling of calves for the butcher, and for the immediate use of the milk.

6184. *The kind of cow used by the dairymen* who supply the London market, is chiefly the Holderness, a variety of the short-horned breed, with large carcasses and short horns. They are bred chiefly in Yorkshire and Durham; but in part in most counties. The Edinburgh dairies are supplied by short-horned cows from Roxburghshire, and other pastoral districts in the south of Scotland. For private dairies, the variety bred in Ayr-

shire (*fig. 648.*) have a decided preference as, giving a rich milk and large proportion of butter; and the cheese made from the milk of this breed, known as Dunlop, is decidedly celebrated. In Lancashire, the native long-horned breed, is said in the Report of that county to obtain the general preference. But in Hodgson's dairy at Caton, in the same district, it was found that a short-horned cow, upon an average of twelve months, will yield nine quarts of milk in the day, and four and a half pounds of butter in the week; and a long-horned cow gives eight quarts of milk in the day, and four pounds of butter in the week, for the same period. The cows of both kinds had constantly the same kind of food; but in order to have the clear result, the quantity of food consumed by each cow of the different breeds, should have been fully ascertained. The produce of milk and butter is on the side of the short-horned sort; but it is not ascertained whether the neat balance is in favor of the short or long-horned. (*Lancashire Rep. 561.*) The Guernsey breed is valued by some for the richness of the cream and butter; but both for the dairy and butcher, it is very unprofitable.



648

6185. *Where butter is the principal object*, such cows should always be chosen as are known to afford the best and largest quantities of milk and cream, of whatever breed they may be. But the quantity of butter to be made from a given number of cows must always depend on a variety of contingent circumstances: such as the size and goodness of the beasts; the kind and quantity of the food; and the distance of time from calving. As to the first, it need scarcely be mentioned that a large cow will give greater store of milk than one of a smaller size; though cows of equal size differ as to the quantity of cream produced from the milk of each: it is, therefore, on those cows whose milk is not only in large abundance, but which, from a peculiar inherent richness, yields a thick cream, that the butter dairy-man is to place his chief dependence; and where a cow is deficient in either of these, she should be parted with, and her place supplied by one more proper for this use. As to the second particular, namely, the kind and quality of the food, those who would wish to profit by a dairy ought to provide for their cows hay of a superior goodness, to be given them in the depth of winter, and this in an unlimited degree, that they may always feed till they are perfectly satisfied. And, when the weather will permit, the cows should be indulged with an outlet to marshes or low meadow-grounds, where they may feed on such green vegetables as are present; which is far preferable to the practice of confining them the whole day on dry meat, will enable them to yield greater plenty of milk, and will give a fine yellow color to the butter even in the winter season.

6186. *In the vales of Buckinghamshire and Oxfordshire*, very great numbers of cows are kept for the purpose of butter. These fertile lands maintain a breed of large cows, which yield great store of milk; so that it is no uncommon circumstance for one farmer to keep a herd of fifty or sixty, and to collect a quantity of cream sufficient to fill a barrel-churn of sixty gallons in a week. The butter made from this cream is sold by the farmer or dairyman, to persons who make it their business to purchase this article at a stated price from Michaelmas to Lady-day, and at an inferior rate from Lady-day to Michaelmas. The butter thus collected is sent to London every week in waggons. It is consigned to the dealers, who retail it to the consumer; and no small profit from this traffic accrues to the waggoner and the butter-merchant. This butter is mostly made up in lumps, containing the quantity of two pounds in each, and for that reason it has obtained the name of lump-butter. Its flavor is peculiarly sweet and agreeable, which is chiefly owing to the goodness of the pasture whereon the cows are fed; for this intrinsic merit would in vain be sought for in butter made from ordinary pastures, how great soever may be the skill of the dairy-woman. And though the grass should be equally luxuriant, the cows of the same breed, and the cream in like abundance, yet would a decided preference still remain in favor of the vale-fed cows; for, as a fattening beast on rich land will thrive much quicker than on thin soils, though the herbage be shorter on the former than on the poor ground, so will cows give a larger store of milk, and that of a more nutritious quality, when fed on deep fertile meadows, than if depastured on those of inferior goodness or quality.

6187. *Epping butter* has long been held in the highest estimation: and great quantities are manufactured in Cambridgeshire and the adjoining counties. The Cambridge butter is sent in small pans; and has an additional quantity of salt mixed with it, to insure its keeping for ten days or a fortnight, and is generally perfectly free from any rancid taste. Yorkshire, Lincolnshire, and other neighboring counties, where the land is rich and fertile, likewise supply large quantities of butter, which is salted and put into tubs for the southern markets.

6188. *Where cheese is the principal object, the management in respect to the cows must be the same.*

6189. *When the object is the suckling of calves, the farmer should provide himself with a breed of cows suited to the quality of his land. Where the farm abounds with fertile pastures, watered with wholesome streams, and not far distant from the yard, so that the cows may be turned immediately out of the suckling house upon their feed, the benefit will be in every respect superior to what can be expected from an arable farm, or where the green land is in a small proportion to the ploughed. For in this latter case, the cows must depend for their sustenance chiefly on artificial fodder; such as clover, rye-grass, turnips, and other roots and herbage.*

6190. *The cow-house should be of a size adapted to the number of the beasts. Each cow should be driven into the house at suckling-time, and her head confined in a proper manner (fig. 649.), having some fodder lying constantly before her, and a space left between every beast. When they become accustomed to this kind of restraint, they will without any trouble come into the places destined for them, when the calves may be suckled with the greatest ease and facility.*

6191. *The time cows should become dry before their calving is not agreed on, some contending, that they may be milked almost to the time of their dropping the calf without injury; while others maintain, that it is absolutely necessary that they should be laid dry from one to two months, both for the advantage of themselves and their calves. It is probable that much in this business must depend on the manner in which they are kept; as where they are well fed they may be continued in milk till within a week or two of their calving, without suffering any injury whatever from it; but in the contrary circumstances it may be better to let them run dry for a month, six weeks, or more, according to their condition, in order to their more fully recruiting their strength. It appears not improbable, but that the longer the milking is continued, the more free the cows will be from indurations and other affections of the udder; which is a circumstance deserving of attention. Where only one or two cows are kept for the supply of a family, it is likewise useful to know, that by good feeding they may be continued in milk without any bad consequences till nearly the time of calving. In the *Agricultural Survey of the West Riding of Yorkshire* it is stated, that no advantage was found on trial to result from allowing the cows to go dry two months before calving. They have there been kept in milk within ten days of the time of dropping the calf. This practice, however, cannot be considered generally advisable.*

6192. *Cows sometimes slip their calves before they are sufficiently grown. Where this occurs, it is essentially necessary to remove such cows immediately from the cow-yards, or from mixing with the other cattle, for a few days. But where cows are much subject to such accidents, it is the best method to get quit of them as soon as possible, as they will seldom turn out profitable afterwards.*

6193. *Cows should be kept constantly in good condition, as where they are ever suffered to become very lean, and that in the winter season, it is impossible that they can be brought to afford a large quantity of milk, by getting them into perfect condition in the summer months. Where cows are lean at the period of calving, no management afterwards is ever capable of bringing them to afford for that season any thing near the proportion of milk that they would have done if they had been supported in proper condition during the winter. Food of the most nourishing and succulent kinds should therefore be regularly given in suitable proportions in the cold inclement months, and the animals be kept warm, and well supplied with pure water. Some advise their being cleaned by combing and other means; but this is a practice, which, though useful in making them yield their milk more freely, can perhaps seldom be employed on an extensive scale with advantage.*

6194. *Where the herd of cows is extensive, an account should always be kept of the time when each cow takes the bull, that she may be dried off at a reasonable distance of time before the expected term of gestation be completed. The usual time when the cow is dried off is two months before her calving, when she ought to be suffered to lie quiet, and not to be brought up with the other cows at milking or suckling-time. According to some, if a cow be continued in milk nearer to the time of calving than the period above allotted, it will not only greatly injure her future progeny by rendering it weakly and stunted, but will also have an ill effect on her own health: while others, as we have seen (6191.), consider ten days or a fortnight as sufficient. When a cow is four months gone with calf, the fact may easily be ascertained by pressing upon her off-flank, when the calf will be felt to kick against the hand.*

6195. *Cows may be known to be near the time of calving, by springing at the udder or at the bearing. By springing at the udder is meant the collection of liquid in the bag,*



which, a few weeks before the time of gestation is accomplished, assumes, in some degree, the appearance of milk, and may be drawn from the teats. To spring at the bearing, is when this part is more than ordinarily large and distended. Heifers are said to spring soonest at bearing, and old cows at the udder. Some cows are peculiarly given to abortions: and where this happens, they should never be continued long in the herd, as being unlikely to yield any considerable degree of profit to the owners of them.

6196. *Cows which are shortly expected to calve*, ought to be lodged at night in a large convenient out-house, or some other place, for a week or two previous to calving, as it may be the means of saving the life of the calf, and perhaps of its dam likewise: for, when a calf drops in the yard or field under such circumstances, the hazard of its perishing through the inclemency of the weather is very great, and it may considerably endanger the life of the cow. But if from inattention, or other causes, the creature should catch cold by calving abroad in sharp winter nights (which may be perceived by a refusal of her food, and by her trembling joints), she ought immediately to be driven into a warm shed, together with her calf, and fed with sugar-sops and ale, and with the best and sweetest hay, and should not be suffered to drink any cold water. By this treatment she will mostly recover in a few days; but should the disorder hang about her, balls composed of aromatic cordial substances may be given.

6197. *A milch cow is in her prime at five years old*, and will generally continue in a good milking state till ten years or upwards; but this depends greatly on the constitution of the animal, some cows, like other animals, exhibiting marks of old age much earlier than others.

6198. *Cows of large size yield great store of milk*, when turned on pastures where the grass is in sufficient abundance, or fed with a constant supply of such food as from its succulency conduces much towards the nutriment of the creature, and enables her to give large quantities of milk, such as turnips, grains, garden-vegetables, &c. But as these large cows require a more ample provision than would fall to their share on the generality of farms, it would seem that they should not be had by those farmers whose land is not of the most fertile kind; for, on ordinary keep, a small cow will yield a fairer profit than one of the Yorkshire or Staffordshire breed, which having been bred on the best kind of land, would be starved where a Scotch or a Welsh cow would find an ample supply of food.

6199. *Those who would make the utmost advantage from cows*, either as calf-sucklers, dairy-men, or milk-sellers, should always provide a bull to run in the herd, to obviate the perpetual trouble of driving them perhaps a mile or more to the bull, and in order to prevent the loss and inconvenience of their becoming frequently barren. One bull will generally be sufficient for twenty cows. These animals are in their prime at two years old, and should never be suffered to continue longer in a state of virility than to the fifth year; as, after that time, bulls which before were gentle and lay quiet in the cow-pastures are mostly apt to contract vicious dispositions, and become very unmanageable. Whenever this happens, they should be immediately castrated.

6200. *For feeding of stalled cows*, the following directions are given to the cow feeder in an improved dairy establishment near Farnham, in Surrey. "Go to the cow stall at 6 o'clock in the morning, winter and summer; give each cow half a bushel of the field beet, carrots, turnips, or potatoes cut; at 7 o'clock, the hour the dairy maid comes to milk them, give each some hay, and let them feed till they are all milked. If any cow refuses hay, give her something she will eat, such as grains, carrots, &c., during the time she is milking, as it is absolutely necessary the cow should feed whilst milking. As soon as the woman has finished milking in the morning, turn the cows into the airing ground, and let there be plenty of fresh water in the troughs; at 9 o'clock give each cow three gallons of a mixture composed of eight gallons of grains and four gallons of bran or pollard; when they have eaten that, put some hay into the cribs; at 12 o'clock give each three gallons of the mixture as before; if any cow looks for more, give her another gallon; on the contrary, if she will not eat what you give her, take it out of the manger, never at one time letting a cow have more than she will eat up clean. Mind and keep your mangers clean, that they do not get sour. At 2 o'clock give each cow half a bushel of carrots, field beet, or turnips; look the turnips, &c., over well before you give them to the cows, as one rotten turnip, &c. will give a bad taste to the milk, and most likely spoil a whole dairy of butter. At 4 o'clock put the cows into the stall to be milked; feed them on hay as you did at milking time in the morning, ever keeping in mind that the cow whilst milking must feed on something. At 6 o'clock give each cow three gallons of the mixture as before. Rack them up at eight o'clock. Twice in a week put into each cow's feed at noon, a quart of malt dust."

6201. *Directions to the dairy maid*. "Go to the cow stall at 7 o'clock; take with you cold water and a sponge, and wash each cow's udder clean before milking; douse the udder well with cold water, winter and summer, as it braces, and repels heats. Keep your hands and arms clean. Milk each cow as dry as you can, morning and evening, and when you have milked each cow, as you suppose, dry, begin again with the cow you first milked, and drip them each; for the principal reason of cows failing in their milk is from negligence in not milking each cow dry, particularly at the time the calf is taken from the

cow. Suffer no one to milk a cow but yourself, and have no gossiping in the stall. Every Saturday night give in an exact account of the quantity of milk each cow has given in the week." (*Farm. Mag.* vol. xv. 314.)

6202. *Harley's dairy establishment at Glasgow* has been celebrated since 1813. The object of the proprietor, who is engaged in various extensive concerns, is to supply the public with new milk free from adulteration, and to have the cow-house, cows, and milk, kept in a more cleanly state than by the usual mode.

6203. *Harley's cow-house* is fitted up upon a new construction. The cattle stand in rows, twelve in a row across the house, head and head, and tail and tail alternately; there is a passage behind for cleaning, and one in front for feeding. In front of each cow is a wire grating, hung like a window sash, which lifts up when giving the soft food and cleaning the cribs, and is put down when they get hay, &c. The contrivances for washing the cribs, collecting the urine, ventilating the house, &c., gives peculiar advantages to the establishment, which may be summed up in the following items: the health of the cattle; the preservation of the timbers; the diminished danger from fire, there being no hay-loft above the cattle; the preservation of the provender; and, the flavor of the milk. The heat is regulated by thermometers. A circulation of air can be produced, so as to keep the cattle comfortable in the hottest weather, by which their health is promoted. The ventilation also prevents the timber from rotting; makes the cows eat their fodder better; as their breath is allowed to escape, instead of being thrown back upon the food, as is the case when their heads are placed opposite a wall. It is well known that milk easily takes a taste from any other substance; of course, if the cow-house is filled with bad air, the milk, while passing from the teat to the pail, and during the time it may stand in the house, will be impregnated with the foul atmosphere.

6204. *In feeding and preparing the food* Harley has made many experiments, and by the mode he now follows, the cattle fatten and milk better, than by the ordinary process; and the milk has no taste from turnips or other vegetables.

6205. *The arrangement for milking*, insures the cows to be clean milked, and also prevents fraud; and the mode of locking up the milk, and at the same time of admitting air, prevents adulteration by the retailer. The cows are not farmed out to milkmen as in London.

6206. *The stock of cows* for some time back, has been 120, averaging eleven English quarts each per day; but both quality and quantity depends much upon the kind of food. Harley gives a decided preference to the Ayrshire breed of cows. They are bought chiefly at country fairs, either newly calved, or a few weeks before calving, and never turned out till they go to the butcher.

6207. *The food of the cows during summer* is cut grass and green barley mixed with old hay; and during winter Harley uses a good many turnips and potatoes, all of which are steamed, and mixed with cut hay and straw; also grains and distillery wash, when these can be got.

6208. *When there is more new milk than supplies the demand*, part is put in the milk-house till next day, when the skimmed milk is sold at half price, and the cream sold at 1s. 6d. per quart. When any cream is left, it is put in a churn and made into butter, once a week or fortnight.

6209. *A table of regulations* has been adopted for the times of feeding, milking, currying the cattle, cleaning the house, &c. Each person has a curry comb and a hair cloth for cleaning the cows twice a day, and a mop and pail for the house, which is washed and sanded twice a day.

6210. *The cleanly state of the cattle and house* make it a treat for visitors to see the establishment; and the way the vessels and milk-house are kept, have made some people fond of milk who formerly were disgusted at it, from the manner in which many town dairies are conducted.

6211. *The advantage of irrigating grass lands with the cow's urine*, almost exceeds belief. Last season some small fields of old grass were cut six times, averaging fifteen inches in length at each cutting, and the sward very thick. The soap-suds of a public washing house are applied to the same purpose with considerable advantage.

6212. *The advantage of this system* to the owner of the cattle is shown by the following abstract, in Harley's own words: but the benefit of a liberal supply of genuine milk to the community at large, particularly to children, it is not easy to estimate

To the general health of the cattle by ventilation	- - - - -	} 15 per cent.
To the prevention of a disease called grain sickness, when fed on grains	- - - - -	
To the prevention of swelling, by eating young and wet grass	- - - - -	} 15 do.
To the prevention of choking, when feeding on turnips or potatoes, &c.	- - - - -	
To saving in the expense of feeding, by improved modes of cooking, &c.	- - - - -	} 20 do.
To saving of labor in feeding, dunging, &c. 50 per cent, as one person will do as much as	- - - - -	
two on the old plan; but allow 25 of this for draining, &c., leaves 25 per cent. profit	- - - - -	} 25 do.
on servants' wages	- - - - -	
To saving of timber in the building, as they will last more than double the time.	- - - - -	50 do.

6213. Harley has a steam-engine for driving the following machinery.

A small threshing-mill.	The churning apparatus.
A straw-cutter.	Pumping water, &c.
A turnip and potato slicer.	The same boiler that drives the engine, steams the food, warms water, &c.

6214. *After much study, labor, and expense*, the establishment is now brought to such a state of perfection, that it receives the cordial approbation of all who have seen it; — furnishing the community with genuine milk at comparatively a low price. It is admitted, that the greater part of the system is original, and is not to be met with in any part of the kingdom. — (*Farm. Mag.*, xv. 189.)

SUBJECT. 8. *Of Working Horned Cattle.*

6215. *The arguments for and against the working of oxen* have been already stated. (4463.) Though horned cattle are gradually disappearing as beasts of labor, it is probable they will in many places be occasionally used as a substitute for horses, or to get up one or two additional teams on extraordinary occasions. Indeed we see no objections to the occasional use of both oxen and cows for this purpose; more especially in such cases as those of a nobleman's farming; as when breaking up his park, or cutting down and carting away timber, or earth, gravel, &c. to an extent, more than can be readily performed by the ordinary teams of the establishment. For these and such like purposes of amateur farmers; and probably occasionally for some purposes on the farms of rent-paying cultivators, the horned cattle of the farm may afford a valuable resource. For these reasons it seems fitting in this work not to consider the working of oxen as altogether an obsolete practice; and we shall, therefore, notice the training, harnessing, shoeing, age of being put to work, and general treatment of these animals so employed.

6216. *The training of the calf intended for labor, according to some, should commence at an early period, and after being accustomed to be handled, he should be taught to present his foot to the shoeing smith, as readily as the horse, which is partially the practice in some places.* No animal, however, is so easily broke as the ox at any age; and in most countries, where they are used in labor, they are never handled till harnessed and put in the plough, or to drag a tree. This is the case both in Devonshire and Herefordshire, and as they are only worked a few years it does not seem desirable to be at any great expense in their training. The Roman practice, in this particular, may deserve imitation. (99.)

6217. *Working oxen when kept in a house are generally confined to their places by the same sort of fastening used for cows, (fig. 650.), in which their neck has free play between two upright spars; but in some establishments a ring of a particular description (fig. 651.) is used, to which they are tied by a halter attached to a head strap or bridle. The ring is generally screwed into the front of the manger or eating trough.*

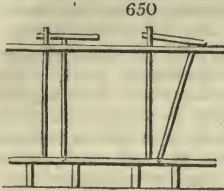

650

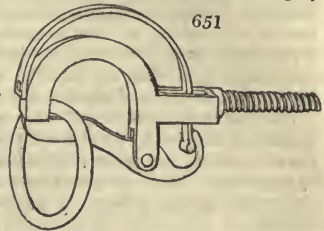

651

The cattle fastening used in Devonshire is a wooden bow put on their necks and fastened to a round post. The bow consists of two pieces — the yoke, which has two slits terminating in round holes, and the bow, which is made of split ash, and has a knob at each end. These knobs being put through the round holes, the elasticity of the bow forces it along the slit and prevents it returning.

6218. *The most approved kind of harness for the ox is little different from that of the horse, excepting in the shape of the collar. In many places, however, and especially on the continent, the ox draws solely by the withers, by means of what is called a yoke and bow. (fig. 652.)*

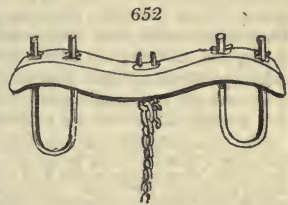

652

6219. *The shoeing of oxen is a practice which is yet far from being performed in a perfect manner. Clark says, that in many parts of France, where the ox is used for draught, it is sometimes necessary to employ eight shoes, one under each nail; or four, one under each external nail; and sometimes only two, one under the external nail of each fore foot. In this country two pieces or shoes to each foot are generally made use of, being mostly fixed on, especially in the northern districts, with three or four large headed nails to each shoe. They are fitted on in a similar manner to those of the horse. But, from the shoes of these animals being from the smallness of the pieces so liable to break, it has been suggested to have them shod with whole shoes in the manner of the horse; but how far this practice would answer, must depend upon future trials. As there is much trouble in the shoeing of these animals, from it being necessary to cast them each time, it has been found requisite to have recourse to contrivances for shoeing them standing (fig. 653.)*

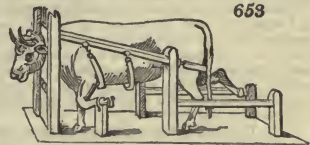

653

6220. *An ox shoe (fig. 654.) consists of a flat piece of iron, with five or six stamp holes on the outward edge to receive the nails; at the toe is a projection of some inches, which passing in the cleft of the foot, is bent over the hoof, so as to keep the shoe in its proper place. This projection is not, however, employed in the general practice of making these shoes.*

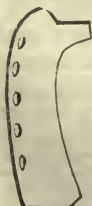

654

6221. *The age at which an ox may be worked is from two and a half to three and a half years. Some begin at two, but it ought to be for very light operations, and such as are not of long duration. The period to which the ox is worked varies from his fifth to the tenth year.*

6222. *Parkinson's father used to make up occasionally an ox team for the plough of four oxen and one horse as a leader, which he found did about two-thirds of the labor of two horses. There are, he says, great objections to ox-teams in the plough. He has, however, found them useful in some sorts of farm-work, from their slow, steady pace; as in scarifying, leading dung, &c., as the work suits them from its being easy, and having a great deal of standing: they are, says he, much cheaper kept than horses, and eat straw in the winter, and are valuable for making dung. He never saw this practice injure their growth. They may be worked from two till five years old, without any loss of time, as they grow to that age, and are then both larger and better beef than three year old steers. He, therefore, recommends ox-teams for leading dung and the other odd jobs, but not to plough and harrow. If they are worked to*

the age of eight or ten years, it is, he thinks, a real injury to the public, and an unprofitable practice to the farmer.

6223. *Bakewell* used to work moderately his heifers whilst carrying their first calves; an unobjectionable practice, provided they be well fed. Bulls are generally allowed to be good laborers, and capable, if high fed, of vast exertions.

6224. *The length of time, per day, which an ox is kept in the yoke, varies according to the kind of labor, and the age and keep of the ox.* If an ox is fed on hay, oats, and some roots, he will plough four days a week; but if on straw and roots only, not above three days. In the former case he is worked two whole days, and two half days, and in the latter case six half days. The latter is the best plan, for which reason, where oxen are regularly worked, two pairs should be kept for each ploughman.

6225. *The most desirable breeds of oxen to work* are the Devonshire and Herefordshire varieties, which are long-legged, quick-stepping animals. Lord Somerville, who has carried the working of oxen to greater perfection than any one else, prefers the Devon breed, which most cultivators consider the quickest walkers in England. When horned cattle are only worked occasionally, whatever sort of animals are on the farm, whether bulls, cows, or oxen, of good or bad breeds, will necessarily be employed.

6226. *The food of horned cattle employed in labor* must be substantial. It is a great mistake to suppose they can work on straw alone. Unless they have roots added to straw in winter, and green food in summer, it will be an idle attempt to harness animals so nourished. The best and indeed the only way is to feed them well with straw, coarse hay, roots, green herbage, or pasturage, as the season and other circumstances may indicate.

#### SUBJECT 9. *Of the Anatomy and Physiology of the Bull and Cow.*

6227. *The general structure of the bull and cow* presents some peculiarities when compared with the horse, whose anatomy having been fully explained, will be taken as the subject of comparison. The ox, as an animal machine, displays less complexity of structure than the horse; but the principal differences between the two will be found to arise from the evident intention of nature to bound the locomotion of horned cattle; the limbs of the ox are therefore not found favorable to speed; nor does his general mass betray that symmetrical proportion and mechanical composition that would fit it to be acted on to advantage, as regards quick motion, by the powerful muscles he evidently possesses. For strength alone will not produce speed.

6228. *The skeleton of the ox* is formed under the above view; and though the number of his bones differs little from that of the horse, the general form differs materially;—the frontal, the occipital, and indeed most of the bones composing the skull are broad and extended, while to the former are appended the horns. These, as we have seen (1822.), partake of the nature of true bone, placed within a membranous envelopment, of a mixed nature between cuticle and cartilage. The ox has no upper nippers; the grass being cropped into a tuft by means of the tongue, is cut off by the under nippers; whereas in the horse it is nipped off by the approximation of both incisive teeth.

6229. *The vertebrae or neck bones* are the same in number and form as in the horse, but from the diminished elevation of the head, and the peculiarity of attachment of the great suspensory ligament, the ox has no cervical crest. The dorsal vertebrae are thirteen, with spinous processes, or withers less high. The lumbar vertebrae are six, and the sacral four; the coccyx or bones of the tail are indefinite in number, from eighteen to twenty-five. The pelvic bones in the ox are very large, and the rugged outline of the rump in cattle, arises from the great rising of the spine of the ilium, and tuberosity of the ischium: the ribs are thirteen, eight of them true, and five false; and upon the former rest the scapulae, which do not materially differ from those of the horse.

6230. *The fore limb bones* are, the arm, and the fore-arm, which, as in the horse, is composed of the radius and ulna, and bears a general resemblance to that of the horse. The knee is composed of four bones in the first row, and two in the second, which renders that joint inferior to that of the horse in complexity and elasticity: the same holds good with regard to the hock, where the bones entering its composition are also less numerous than in the horse. The canon or shank has no splint bones attached to it, but it is lower, and enlarges into two articular portions corresponding with the metacarpal before, and metatarsal bones behind: thus from the pastern downwards, the limb is double, and ends in two separate hoofs, which present, individually, a similarity of structure and design to the single hoof of the horse, but less developed; to the posterior part of each, are appended two imperfect phalanges or claws, thus keeping a connection with the digiti.

6231. *The hinder limbs* present nothing remarkable, but preserve the same increased simplicity of structure with the fore.

6232. *The viscera of the chest* offer no peculiarities from those of the horse to deserve notice; neither is the economy of the organs concerned, different.

6233. *The viscera of the belly of the ox* have some specialties, the principal of which consist in the digestive organs, which differ in form, structure, and economy, in some essential particulars, from the same system in the horse.

6234. *The ox has four stomachs*, in which formation, the goat, sheep, camel, and deer, participate. As it is necessary that these animals should collect much herbage for their support; and as it would fatigue and keep them too long in motion to gather and masticate such a quantity at the same time, so a peculiar provision has been made for them, by which, they first hastily collect their food, pass it into a reservoir, and afterwards commence the mastication of it at their leisure.

6235. *The first stomach, rumen, or paunch*, is a very large membranous and muscular bag, principally occupying the left side, and extending, when full, from the middle of the ribs to the haunch, into which the unruminated food is received; consequently, it is the over-distention of this which occasions the malady called boven: it is in this stomach also that the concretions called hair balls are found. It presents numerous processes to assist in the retention of the food.

6236. *The second stomach*, called also reticulum, bonnet, or kingshood, would appear as a globular appendage to the paunch merely, were it not for its peculiarity of structure, which resembles the cells of the honey-comb, and which is well known to the eaters of tripe. The oesophagus, or gullet, enters at the junction of this with the first stomach, and is continued in the form of a muscular ridge, or segmental tube along the line of junction between these two stomachs, and which is from thence continued into the



*many-plics.* In the hornless ruminants, the second stomach is exclusively designed as a reservoir for water, and is capable of holding and preserving a vast quantity of it. A little of this water is passed up, as wanted, to be mixed with the dry matters chewed during rumination. In the deserts of Arabia, where water is met with only at long distances, this reservoir is peculiarly advantageous to the camel and dromedary; and the Arabian travellers, when famishing for water, save themselves frequently at the expense of their camels, by killing of which, and taking out this stomach, they find a supply.

6237. *The third stomach* is named after its foliated structure *many-plics*; there are about eighty or ninety of these septa or folds, which are covered with cuticle, in common with the two former stomachs, by which, some resemblance is kept up between the digestive processes of the horse and ruminants. By the comparative insensibility of these stomachs, they can also bear potent medicines, which would be destructive to the carnivoræ. By this curious extension of surface, the ruminated food is applied and re-applied to the sides of the bag, to be acted upon in its early stage of digestion.

6238. *The fourth stomach*, called also the *red bag*, abomasum faliscus, and ventriculus intestinalis, is about two feet nine inches long in an ox, and resembles the simple digestive stomach of the mammalia. It is in this stomach that the pulaceous mass of the chyme undergoes a more perfect animalization by being mixed with the gastric fluid, which appears to be wholly secreted here, and thus it is that this stomach only produces rennet. The red bag, to increase its secreting surface, has likewise about nine longitudinal plicæ to each side, with an intervening rugose structure.

6239. *Rumination, or chewing the cud*, is the process whereby the ruminant animals collect their food, and with little or no mastication; when such food is perfectly soft and moist, as in grass, they form it into a bolus, and, with little expenditure of saliva, they pass it down the gullet into the paunch, which, when it has become distended with a sufficient quantity, stimulates the animal to seek for rest and quiet, and he commonly lies down. The paunch begins now to exert its extraordinary powers of separating a portion from the contained mass, and to return it into the mouth, where it undergoes a complete mastication; being retained from falling out of the mouth again by the numerous papillæ or roughnesses on the tongue, which are pointed backwards, and also by the ridges of the palate: sufficiently masticated, and mixed with the saliva, it is again passed down the throat, but instead of again entering the first stomach, the muscular gutter forms itself into a tube, and carries it at once into the third stomach, where, having to undergo a further change, it is passed into the red bag, or fourth stomach; to undergo a further solution by means of the gastric fluid, preparatory to its being converted into nutriment under the name of chyle.

6240. *The intestines of the ox* have not their divisions into great and small so well marked as in the horse; yet the tract is very extended, to admit of a perfect separation of all the chylous particles. In the intestines of the horse, it has been shown (5729.) that much of the digestive as well as the operative process goes on; but the chymous mass is more broken down in the stomachs of a cow than by the united forces of the stomachs and intestines of the horse. Grass, containing less organical moluculæ than grain, requires to be minutely acted on to afford nutriment; and thus the well fed horse, after having been sufficiently nourished, passes off dung containing much of the original principles of his farinaceous food, and which forms excellent manure; while that of the ox is almost wholly decomposed, merely fæculent, and unfitted for this purpose.

6241. *The liver of the ox* is large, and presents a gall-bladder, which that of the horse does not. This gall bag is furnished by several hepatic ducts leading into the neck of the gall duct. By the existence of a gall bladder, the bile is evidently more concentrated; but it is difficult to understand why this should be necessary to the ruminants and not to the horse.

6242. *The pancreas of the ox* is of a lozenge form. The *spleen* is very large, and is placed on the left side of the paunch. The biliary and pancreatic ducts unite together. The principal fold of the *omentum* is very large, and incloses the four stomachs, and part of the intestines. The *renal capsules* are flat and triangular. The kidneys are lobulated.

6243. *The organs of generation* in the cow differ but little from those of the mare, and other mammalia. The penis in the bull is more pointed and taper than that of the horse. The vesiculæ seminales are wanting, but have a small ligamentous bridge instead. The prostates are two.

#### SUBJECT. 10. Of the Diseases of Horned Cattle.

6244. *Cattle are subject to some very dangerous diseases*, but as their life is less artificial, and their structure less complex, they are not liable to the variety of ailments which affect the horse. The general pathology of the horse and ox being little different, the fundamental rules for veterinary practice, and the requisite medicines, when not particularized, will be found in the *Veterinary Pharmacopœia*, already given. (5879.)

6245. *Mild fever*, pantas or pantasia. Cattle sometimes appear affected with heat, redness of the nostrils and eyelids: they refuse food, are dull, evacuate and stale with difficulty; and the urine is high colored. These symptoms are often aggravated every other day, giving it the appearance of an intermittent affection. The complaint is often brought on by over-driving in very hot weather, occasionally by pushing their fattening process too fast. If there be no appearance of malignancy, and the heaving be considerable, bleed, and give half an ounce of nitre in a drink night and morning; but unless the weather be cold do not house the animal.

6246. *Inflammatory fever* is called among farriers, cow-leeches, and graziers, by the various names of black quarter, joint felon, quarter evil, quarter ill, showing of blood, joint murrain, striking-in of the blood, &c. Various causes may bring this on. It is sometimes epidemic, and at others it seems occasioned by a sudden change from low to very full keep. Over-driving has brought it on. No age is exempt from it, but the young oftener have it than the mature. Its inflammatory stage continues but a few days, and shows itself by a dull heavy countenance, red eye and eyelids: the nostrils are also red, and a slight mucus flows from them. The pulse is peculiarly quick; the animal is sometimes stupid, at others watchful, particularly at first; and in some instances irritable. The appetite is usually entirely lost at the end of the second day, and the dung and urine either stop altogether, or the one is hard, and the other red. About the third day a critical deposit takes place, which terminates the inflammatory action: and it is to the various parts on which this occurs, that the disease receives its various names. The deposit is, however,

sometimes universal, in the form of a bloody suffusion throughout the whole skin. In others, swellings form on the joints, or on the back or belly; and in fact, no part is exempt from their attack. Sometimes the animal swells generally or partially, and the air being suffused under the skin, crackles to the feel. After any of these appearances have come on, the disease assumes a very malignant type, and is highly contagious.

6247. *Treatment of inflammatory fever.* Before the critical abscesses form, or at the very outset of the disease, bleed liberally, and purge also: give likewise a fever drink. (5910.) If, however, the disease be not attended to in this early stage, carefully abstain from bleeding, or even purging: but instead, throw up clysters of warm water and salt to empty the bowels, and in other respects treat as detailed under malignant epidemic. (5767.) It may be added, that four drachms of muriatic acid in three pints of oak bark decoction, given twice a-day, has proved useful. The swellings themselves may be washed with warm vinegar, both before and after they burst.

6248. *Catarrh or influenza* in cattle, also known by the name of *felon*, is only a more mild form of the next disease. Even in this mild form it is sometimes epidemic, or prevalent among numbers; or endemic by being local. Very stormy wet weather, changing frequently, and greatly also in its temperature, are common causes. We have seen it brought on by change of food from good to bad; and from too close pasturage. It first appears by a defluxion from the nose; the nostrils and eyelids are red; the animal heaves, is tucked up in the flanks, and on the third day he loses the cud. There is a distressing and painful cough, and not unfrequently a sore throat also, in which case the beast almost invariably holds down his head. The treatment does not at all differ from that directed under the same disease in horses. (5765.) Bleeding only the first two days, carefully sheltering, but in an open airy place, and littering well up.

6249. *The malignant epidemic influenza* is popularly called the *murrain* or *pest*; and has at various times made terrible havoc among cattle. Ancient history affords ample proof of its long existence; and by the accounts handed down, it does not seem to have varied its types materially. In 1757 it visited Britain, producing extreme fatality among our kine. From 1710 to 1714 it continued to rage on the Continent with unabated fury. (*Lancisi's Disputatio Historica de Bovilla Peste.*) The years 1730 and 1731, and from 1744 to 1746, witnessed its attack, and produced many written descriptions of it, among which stand pre-eminent, that of Sauvages, the celebrated professor of medicine at Montpellier. The British visitation of the malady in 1757, elicited an excellent work from the pen of Dr. Layard, a physician of London, which was afterwards translated into several other languages.

6250. *Symptoms of the murrain.* Dr. Layard describes it as commencing by a difficulty of swallowing, and itching of the ears, shaking of the head, with excessive weakness and staggering gait; which occasioned a continued desire to lie down. A sanious fetid discharge invariably appeared from the nostrils, and eyes also. The cough was frequent and urgent. Fever exacerbating, particularly at night, when it usually produced quickened pulse. There was a constant scouring of green fetid dung after the first two days, which tainted every thing around: even the breath, perspiration, and urine were highly fetid. Little tumors or boils were very commonly felt under the skin, and, if about the seventh or ninth day these eruptions become larger, and boils or buboes appeared with a lessened discharge of faeces, they proved critical, and the animal often recovered; but if, on the contrary, the scouring continued, and the breath became cold, and the mouth dark in color, he informs us, mortality followed. Sauvages describes the murrain as shewing itself by trembling, cold shivers, nose excoriated with an acrid discharge from it; purging after the first two days, but previous to which there was often costiveness. Great tenderness about the spine and withers was also a characteristic, with emphysema, or a blowing up of the skin by air discharged underneath it.

6251. *Dissections of those that have died* of this disease, according to Sauvages, have shown marks of great inflammation, and of a great putrid tendency; but the solid parts seldom ran into gangrene. The fluid secretions, however, always were sufficiently dissolved and broken down by putridity. The paunch, he says, was usually filled with undigested matter, and the other stomachs highly inflamed: the gall bladder was also commonly distended, with acrid thick brown bile. Goelich, who likewise dissected these subjects, describes the gall as particularly profuse and intolerably fetid. According to him, the whole alimentary canal, from the mouth to the anus, was excoriated; and Lancisi, contrary to Sauvages, found the viscera of the chest and belly, in some cases, sphacelated and gangrenous. Gazola describes the murrain as accompanied with pustulous sores; and so great was the putrid tendency, that even the milk, before it dried up, which it usually did before the fourth day, became fetid.

6252. *The treatment of the murrain.* In the very early stages, all eminent authors recommend bleeding; but which should not only be confined to the very early periods, as to the first two days; but also to such subjects as by their previous health and condition can bear it. The animals should be placed in an open airy place; the litter should be frequently renewed; and the place itself should be fumigated with the preventive fumigation. (5913.) It has been recommended to burn green boughs with pitch as a substitute: even charcoal fires occasionally carried round the place would be useful. Dr. Layard advised the body to be washed with aromatic herbs in water; but vinegar would have been better. In early stages, saline purgatives, as from ten to twenty ounces of Epsom salts, are to be invariably used. If the scouring have already come on, still, however, purge; but with only half the quantity: an artificial purge will carry off the morbid bile; and if excessive weakness do not come on, the same may be advantageously repeated. Setons are also recommended in the dewlap. When abscesses appear, they may be opened, and their contents discharged, washing the wound with brandy or vinegar, if putrid sloughing takes place. The emphysematous swellings, or cracklings may also be opened, and the air discharged. The other essentials of medical treatment, as detailed under malignant epidemic among horses, is here applicable in every particular. When recovery takes place, it is usually a very slow process, and requires care to prevent other diseases supervening. The animals should continue to be housed, and neither exposed to sun or wind for some time, and the feeding should be nutritious.

6253. *The prevention of the murrain*, or the prevention of its spreading, in many respects is even more important than its medical treatment. Where it has already appeared, all the out-buildings, but particularly the ox-lodges or stalls, should be daily fumigated with the preventive fumigation (5913); and, even the whole of the infected districts should have frequent fires of green wood made in the open air, and every such district should be put under a rigorous quarantine. The cattle on every farm should be carefully examined three or four times every day, and the moment one is found to droop, he should be removed to a distance from the others. In very bad weather, while it is prevalent, the healthy cattle should be housed, and particularly well fed; and their pasture should also be changed. The bodies of those who die of the disease should be buried with their skins on, very deep in the earth, and quick-lime should be strewn over them.

6254. *Phrenzy fever*, or inflammation of the brain, called also *sough*, now and then, but by no means frequently, attacks cattle. The symptoms differ but little from those which attack horses. The treatment must be exactly similar.

6255. *Inflammation of the lungs* occasionally occurs in cattle, in which also the symptoms, progress, and proper treatment, are similar to those detailed under that head in horse pathology.

6256. *Inflammation of the stomach* sometimes occurs from poisonous matters; and in such cases, when the nature of the poison is discovered, the treatment detailed under poison in horse pathology must be pursued. But there is a species of indigestion, to which cattle are liable in the spring, from eating voraciously of the young sprouts of wood; to which some woods are more conducive than others. The symptoms are heat, thirst, costiveness, lessened urine, quick and hard pulse, with heat and redness in the mouth and nose; the belly is hard and painful, and the stools, when they appear, are covered with glare. When the mouth and nose discharge a serous fluid, the animal usually dies.

6257. *Treatment.* Bleed at first, open the bowels by saline purgatives. (5916.) After this give large quantities of nitrated water, and glister also largely.

6258. *The hove or blown* in cattle is also an inflammatory affection of the paunch, ending in paralysis and rupture of its substance. From the frequency of its occurrence, it has become a subject of investigation with almost every rational grazier, and a particular matter of inquiry with every agricultural body; from whence it is now very successfully treated by the usual attendants on cattle, when skilful; but when otherwise, it usually proves fatal. It is observed to be more frequent in warm weather, and when the grass is wet. When either oxen, cows, or sheep, meet with any food they are particularly fond of, or of which they have been long deprived, as potatoes, turnips, the different grasses, particularly red clover; they eat greedily, and forget to lie down to ruminate, by which means the first stomach, or paunch, becomes so distended as to be incapable of expelling its contents. From this inflammation follows, and fermentation begins to take place: a large quantity of air is let loose, which still adds to the distention, till the stomach either bursts, or, by its pressure on the diaphragm, the animal is suffocated. The situation of the beast is known by the uneasiness and general swelling of the abdomen; with the circumstances of the animal being found with such food, or the presumption that it has met with it.

6259. *Treatment.* There are three modes of relieving the complaint, which may be adverted to according to the degree of distention, and length of time it has existed. These are the internal medicines; the introduction of a *probang* of some kind into the paunch by the throat; and the puncturing it by the sides. Dr. Whyatt, of Edinburgh, is said to have cured eighteen out of twenty hoved cows, by giving a pint of gin to each. Oil, by condensing the air, has been successfully tried. Any other substance, also, that has a strong power of absorbing air, may be advantageously given. Common salt and water, made strongly saline, is a usual country remedy. New milk, with a proportion of tar equal to one-sixth of the milk, is highly spoken of. A strong solution of prepared ammonia in water often brings off a great quantity of air, and relieves the animal. Any of these internal remedies may be made use of when the hoven has recently taken place, and is not in a violent degree. But when otherwise, the introduction of an instrument is proper, and is now very generally resorted to. The one principally in use is a species of *probang*, invented by Dr. Monro, of Edinburgh. Another, consisting of a cane of six feet in length, and of considerable diameter, having a bulbous knob of wood, has been invented by Eager, which is a more simple machine, but hardly so efficacious. It is probable that, in cases of emergency, even the larger end of a common cart-whip, dexterously used, might answer the end. But by far the best instrument for relieving, hoven cattle, as well as for clystering them, is Read's enema apparatus, which is alike applicable to horses-cattle, and dogs. It consists of a syringe, (*fig. 665.\* a.*) to which tubes of different kinds are applied, accord-

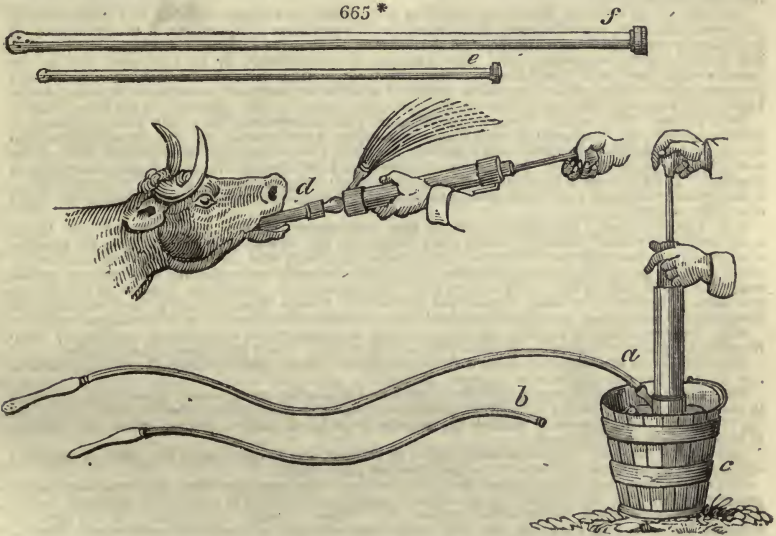

ing to the purpose, and the kind of animal to be operated upon. There is a long flexible tube or giving an enema to horses and cattle, (*a*), and a smaller one for dogs (*b*). To relieve hoven bullocks effectually, it is necessary not only to free the stomach from an accumulation of gas, but from the fermenting pultaceous mixture which generates it; for this purpose a tube (*f*) is applied to the extremity of the syringe, and then passed into the animal's stomach through the mouth (*d*), and being put in action, the offending matter is discharged by a side opening. When the same operation is performed on sheep, a smaller tube (*e*), is made use of. The characteristic excellency of Read's instrument is, that there is no limit to the quantity of fluid that may not be injected or extracted. The same syringe is used for extracting poison from the stomach of man, for smoking insects, extinguishing fires, and syringing fruit trees. (*Encyc. of Gard.* 1419.) The introduction of any of these instruments may be effected by the help of an assistant, who should hold the horn of the animal by one hand, and the dividing cartilage of the nose with the other; while the operator himself, taking the tongue in his left hand, employs his right in skilfully and carefully introducing the instrument; the assistant bringing the head and neck into such an attitude as to make the passage nearly straight, which will greatly facilitate the operation. But when no instruments can be procured, or as cases may occur when indeed it is not advisable to try them, as when the disease has existed a considerable time, or the animal has become outrageous, or the stomach so much distended with air, that there is danger of immediate suffocation or bursting; in these instances the puncture of the maw must be instantly performed, which is called *paunching*. This may be done with the greatest ease, midway between the ilium, or haunch-bone, and the last rib of the left side, to which the paunch inclines: a sharp penknife is frequently used; and persons in veterinary practice should always keep a long trochar, which will be found much the most efficacious, and by far the most safe, as it permits the air escaping certainly and quickly, at the same time that it prevents its entrance into the cavity of the abdomen, which would occasion an equal distention. As soon as the air is perfectly evacuated, and the paunch resumes its office, the trochar may be removed; and, in whatever way it is done, the wound

should be carefully closed with sticking plaster or other adhesive matter. It is necessary to observe, that this operation is so safe, that whenever a medical assistant cannot be obtained, no person should hesitate a moment about doing it himself. After relief has been afforded by means of either the probang or the paunching, a stimulant drink may yet be very properly given, such as half a pint of common gin; or one ounce of spirit of hartshorn in a pint of ale, or two ounces of spirit of turpentine in ale, may any of them be used as an assistant stimulus. When also the cud is again chewed, still some relaxation of the digestive organs may remain; at first, therefore, feed sparingly, and give, for a few mornings, a tonic. (5882. No. 1.)

6260. *Inflammation of the bowels, or red colic*, is by no means unknown in cattle pathology; the symptoms of which do not differ from those common to the horse, and the *treatment* also is in every respect the same. (5797.)

6261. *Inflammation of the liver, or hot yellows*, sometimes occurs, in which case, in addition to the symptoms detailed under hepatitis in the horse (5810.), there is, from the presence of systic bile in the ox, a more determined yellowness of the eyelids, mouth, and nostrils; the *treatment* must be similar. (5810.)

6262. *Inflammation of the kidneys, called red water* by the cow-leeches, is not uncommon among cattle, and is, perhaps, dependent on the lobulated form of these parts in them. The animal, to the other symptoms of fever, adds stiffness behind, and often straddles, but always shrinks on being pinched across the loins, where frequently increased heat is felt; the urine is sometimes scanty, and now and then increased in quantity, but it is always first red, then purple, and afterwards brown or black, when a fatal termination may be prognosticated. The *treatment* has been fully detailed under nephritis, in the horse pathology (5812.), and which consists in plentiful bleedings, &c., but carefully abstaining from the use of diuretics, as advised by ignorant cow-leeches.

6263. *The black water* is only the aggravated and latter stages of the above.

6264. *Inflammation of the bladder* also now and then occurs, and in no wise differs from the cystitis of the horse in consequences and *treatment*. (5814.)

6265. *The colics of cattle* arise from different causes: they are subject to a *spasmodic colic*, not unlike that of horses, and which is removed by the same means. (5805.) *Costiveness* also brings on a colic in them, called *clue bound, fardel bound*, &c. which often ends in the *red colic*, unless early removed; the *treatment* of this we have fully detailed. (5807.) Another colic is accompanied with relaxation of bowels.

6266. *Diarrhœa, scouring, or scouring cow*, is common in cattle, and is brought on by exposure to rain, improper change of food, over-driving, and other violences. It is essentially necessary that the animals be taken under cover, kept warm, and dry, and have nutritious food allowed them. The *medical treatment* has been detailed. (5804.)

6267. *Dysentery, or braxy, bloody ray, and slimy flux*, differs from simple scouring, in a greater degree of fever attending it, and in its being an inflammation of a particular kind, and part of the intestines. It is frequently dependent on a vitiated putrid state of the bile, brought on by over-driving in hot weather, low damp pastures in autumn, &c. The discharge is characterised by its bad smell, and by the mucous stringy patches in it, and also by its heat and smoking when voided: all which are very different from the mere discharge of the aliments in a state of solution in diarrhœa, and which differences should be carefully marked, to distinguish the one from the other: *treat* as under dysentery in the horse. (5801.)

6268. *Yellows*. When active fever is not present, and yet cattle are very dull, with great yellowness of eyelids, nostrils, &c., it arises from some biliary obstruction, to which oxen and cows are more liable than horses, from their being furnished with a gall bladder; it is a more common complaint in some of the cold provinces on the continent, where they are housed and stall fed all the year round, than it is in England. The *treatment* is the same as detailed for chronic inflammation of the liver in horses, (5811.) adding in every instance to it, a change of pasturage, and if convenient, into salt marshes, which will alone often effect a cure.

6269. *Loss of the cud*. This enters the list of most cow-leeches' diseases, but is less a disease than a symptom of some other affection; indeed it is evident that any attack sufficient to destroy the appetite, will generally occasion the loss of the cud. It is possible, however, that an occasional local affection, or paralysis of the paunch may occur, particularly when it is distended with unhealthy substances, as acorns, crabs, the tops of some of the woody shrubs, &c. The *treatment*, in such cases, consists in stimulating the stomach by tonics, as aloes, pepper, and gin mixed: though these, as liquids, may not enter the stomach in common cases, yet in this disease or impaired action of the rumen, they will readily enter there.

6270. *Staggers, daisey, or turning*, are sometimes the consequences of over-feeding, particularly when from low keeping cattle are suddenly moved to better pasturage. *Treat* with bleeding and purging.

6271. *Tetanus, or locked jaw*, now and then attacks cattle, in which case it presents the same appearances and requires the same *treatment* as in horses. (5763.)

6272. *Cattle surgery* is in no respect different from that in practice among horses, the wounds are treated in the same manner. Goring with the horns will sometimes penetrate the cavity of the belly, and let out the intestines: the *treatment* of which is the same as in the horse. (5808.) Strains, bruises, &c. are also to be *treated* like those of horses.

6273. *Foul in the foot*. This occasionally comes on of itself, but is more often the effect of accident: cleanse it well, and keep it from dirt:—apply the foot paste. (5918.)

6274. *Worms, or puckeridge*, are tumors on the backs of cattle, occasioned by a dipterous insect which punctures their skin, and deposits its eggs in each puncture, but which is erroneously attributed to the fœrn owl or goat-sucker (*Caprimulgus europæus*, L.). When the eggs are hatched, and the larvæ or maggots are arrived at their full size, they make their way out, and leave a large hole in the hide, to prevent which the destruction of the egg should be attempted by nipping the tumor, or thrusting in a hot wire.

6275. *Cattle obstetrics* are not very varied; young cows of very full habits have sometimes a superabundant secretion of milk before calving, which produces fever and heat; sometimes, from cold taken; the same will occur after calving also: in either case, give mild dry food, or hay, bathe the udder also with vinegar and water: in some cases, warm fomentations do best. If the fever run high, *treat* as under fever in horse pathology.

6276. *The process of calving* is usually performed without difficulty; sometimes, however, cross presentations take place, and sometimes a constriction of parts prevents the natural passage of the calf. To act properly on these occasions, great patience is required, and much mildness: many cows have been lost by brutal pulling; we have seen all the men and boys of the farm mustered to pull at a rope affixed about a calf, partly protruded, which, when it was thus brought away, was forced to be killed, and the mother soon died also from the protrusion of parts this brutal force brought with the calf. A steady moderate pull, during the throes of the animal, will assist much; having first directed the attention to the situation of the calf, that the presentation is such as not to obstruct its progress; if it does, the calf must be forced back, and turned or placed aright.

6277. *Whethering, or retention of the after-birth or burden*.—It sometimes happens that this is retained; for which no better remedy has been hitherto discovered than warm clothing and drenching with ale, administered as a forcer.

6278. *The diseases of calves* are principally confined to a species of *convulsions* which now and then attacks them, and which sometimes arises from worms, and at others from cold. When the first cause operates, it is then relieved by giving a mild aloetic purge, or in default of that, a mild dose of oil of turpentine, as half an ounce, night and morning. In the second, wrap up the animal warm, and drench with ale and laudanum a drachm. Calves are also very subject to diarrhœa or *scouring*, which will readily yield to the usual medicines. (5883.)

SECT. II. *Of the Buffalo.*—*Bos bubulus*, L. *Buffle*, Fr.; *Buffalo*, Span.; *Büfflochs*, Ger.; and *Bufile*, Ital.

6279. *The buffalo* is found wild in India, America, and various parts of the globe, and is in some degree domesticated in many countries. He is gregarious, docile, alert, and of surprising strength; his carcase affords excellent beef; and the horns, which are jet black, and of a solid consistence, take a polish of wonderful beauty: they can be converted into fabrics of use and ornament, such as mugs, tumblers, knife-handles, &c. In this way they sometimes apply them; and when ornaments of silver or mother-of-pearl are employed, the contrast with the polished black of the horn is agreeably striking. The boss on the shoulders is, as well as the tongue, extremely rich and delicious, and superior to the best English beef. It is usual to cure the tongues for sale. The buffalo far surpasses the ox in strength. Judging from the extraordinary size of his bones, and the depth and formation of his chest, some consider him twice as strong as the ox, and, as an animal of labor, he is generally preferred in Italy. In this country the ingenious physiologist, Hunter, has caused buffaloes to be trained to work in a cart; at first they were restive, and would even lie down; but afterwards they became steady, and so tractable, that they were driven through the streets of London in the loaded cart as quietly and steadily as in Italy or India.

6280. *The buffalo is kept in several gentlemen's parks* as an object of luxury, and has been trained and worked by Lords Sheffield, Egremont, and some other amateur agriculturists. Many prefer his flesh, and some his milk, to that of the bull family.

6281. *The breeding, rearing, and general treatment* of the buffalo may be the same as those of the bull family.

---

#### CHAP. V.

##### *Of the Dairy and its Management.*

6282. *The manufacture of butter and cheese* is of necessity carried on where the milk or raw material is at hand. The subject therefore forms a part of farm management, more or less on every farm; and the principal one in dairy farms. In most of those countries where the profit of the cow arises chiefly from the subsequent manufacture of the milk, the whole care and management of the article rests with the housewife, so that the farmer has little else to do but to superintend the depasturing of his cattle; the milking, churning, and in short, the whole internal regulation of the dairy, together with the care of marketing the butter, where the same is made up wholly for home-consumption, falling alone upon the wife. In this department of rural economy, so large a portion of skill, of frugality, cleanliness, industry, and good management, is required in the wife, that without them the farmer may be materially injured. This observation will indeed hold good in many other parts of business which pass through the hands of the mistress in a farm-house; but there is none wherein he may be so greatly assisted, or so materially injured, by the good conduct or want of care in his wife, as in the dairy.

6283. *The operations of the dairy* in all its branches, are still conducted, perhaps more empirically than those of any other department of husbandry, though it would appear that science, chemistry in particular, might be applied to discover the principles, and regulate the practice of the art, with facility and precision. We have heard it admitted, an eminent author observes, even by experienced dairymen, that the quality of their cheeses differs materially in the same season, and without being able to assign a reason. Every one knows how different the cheese of Gloucester is from that of Cheshire, though both are made from fresh milk, the produce of cows of the same breed, or rather, in both counties, of almost every breed, and fed on pastures that do not exhibit any remarkable difference in soil, climate, or herbage. Even in the same district, some of what must appear the most important points are far from being settled in practice. Marshal, in his *Rural Economy of Gloucestershire*, has registered a number of observations on the heat of the dairy-room, and of the milk when the rennet was applied in cheese-making; on the time required for coagulation; and the heat of the whey after; which are curious, only because they prove that no uniform rule is observed in any of these particulars. The same discrepancy is observable in all the subsequent operations till the cheese is removed from the press, and even afterwards in the drying room. One would think the process of salting the cheeses the most simple of all; and yet it is sometimes, as in the west of Scotland, mixed with the curd; in other instances poured into the milk, in a liquid state, before being coagulated; and still more commonly, never applied at all till the cheeses are formed in the press, and then only externally. In treating of the dairy we shall first offer a few remarks on the nature of milk, and the properties of that of different animals; and next consider the dairy house and its furniture, milking, churning, cheese-making, and the different kinds of cheese, butters, creams, and other products of the dairy.

SECT. I. *Of the Chemical Principles of Milk, and the Properties of the Milk of different Animals.*

6284. *The milk* used by the human species is obtained from various animals, but chiefly the cow, ass, ewe, goat, mare, and camel; that in most general use in British dairying is the milk of the cow, which in modern times has received great improvement in quantity as well as quality, by ameliorations in the form of milch cows, in their mode of nourishment, and in the management of the dairy. Whatever be the kind of animal from which milk is taken, its external character is that of a white opaque fluid, having a sweetish taste, and a specific gravity somewhat greater than that of water. Newly taken from the animal, and allowed to remain at rest, it separates into two parts; a thick white fluid called cream, which collects on the surface in a thin stratum; and a more dense watery body, which remains below. The quantity and quality of cream, and the time it requires to separate from the milk, vary according to the nature of the milk and the temperature of the atmosphere. Milk which has stood some time after the separation of the cream first becomes acescent, and then coagulates. When the coagulum is pressed gently, a serous fluid is forced out, and the remainder is the caseous part of milk, or pure cheese.

6285. *Butter*, or solidified cream, one of the most valuable products of milk, is obtained artificially by churning; an operation analogous in its effects to shaking or beating, by which the cream separates from the caseous part and serum, in a more solid form than when left to separate spontaneously. It is afterwards rendered still more solid by beating with a wooden spatula.

6286. *Cheese* is obtained by first coagulating the milk, either with, or deprived of, its cream, and then expressing the serum or whey; the consolidated curd so produced forms cheese. The milk may be coagulated in various ways, but that effect is chiefly produced by the use of rennet, which is prepared by digesting the coat of young ruminating animals, especially that of the calf. The rennet is poured into the milk when newly brought from the cow, or the milk is warmed to 90° or 100° for that purpose. The richness of cheese depends on the quantity of cream which the milk may have contained; its quality of keeping to the quantity of salt added; and the degree of pressure used to exclude the whey.

6287. *Whey* expressed from coagulated milk, if boiled, and the whole curd precipitated, becomes transparent and colorless. By slow evaporation it deposits crystals of sugar, with some muriate of potash, muriate of soda, and phosphate of lime. The liquid which remains after the separation of the salts, is converted by cooling into a gelatinous substance. If whey be kept it becomes sour, by the formation of an acid, which is called the lactic acid; and it is to this that the spontaneous coagulation of milk after it remains at rest is owing. Milk may after it is sour be fermented, and it will yield a vinous intoxicating liquor. This is practised by the inhabitants of the most northerly islands of Europe, with butter-milk, and by the Tartars with the milk of the mare. Milk is likewise susceptible of the acetous fermentation.

6288. *The constituent parts of milk* are found to be oil, curd, gelatine, sugar of milk, muriate of soda, muriate of potash, phosphate of lime and sulphur. These substances enter into the milk of all animals, but the proportions vary in different species. The various milks in use as food are thus distinguished.

6289. *Cow's milk* produces a copious, thick, and yellow cream, from which a compact consistent butter is formed; the curd is bulky, and retains much serum, which has a greenish hue, a sweet taste, and contains sugar of milk, and neutral salts. The milk of the buffalo is essentially the same as that of the cow.

6290. *Ass's milk* throws up a cream resembling that of woman's milk; the butter made from it is white, soft, and disposed to be rancid; the curd is similar to that of the woman, but not unctuous; the whey is colorless, and contains less salts, and more sugar, than that of the cow.

6291. *Ewe's milk* throws up as much cream as that of the cow, and of nearly the same color; the butter made from it is yellow and soft; the curd is fat and viscid; the whey is colorless, and contains the smallest quantity of sugar of any milk, and but a small portion of muriate and phosphate of lime.

6292. *Goat's milk* produces abundance of cream, which is thicker and whiter than that from the cow; the butter is white and soft, and equally copious, and so is the curd, which is of a firmer consistence than that of the cow, and retains less whey.

6293. *Mare's milk* produces a very fluid cream, similar in color and consistence to good cow's milk before the cream appears on the surface; the butter made from it has but little consistence, and is readily decomposed. The curd is similar to that obtained from woman's milk, and the whey has little color, and contains a large proportion of saccharine matter, and of saline substances.

6294. *Camel's milk* throws up little cream, which is whitish and thin, and affords an insipid whitish butter; the curd is small in quantity, and contains but little whey, which is colorless and somewhat saccharine.

6295. *In the use of these milks*, that of the camel is chiefly confined to Africa and China, and that of the mare to Tartary and Siberia. In India the milk of the buffalo is preferred by the natives to that of the domestic cow. The milk of the goat is more generally used in Italy and Spain, than in any other countries in Europe; they are driven into Leghorn, Florence, Madrid, and other towns, in flocks early in the morning, and milked in the streets. The goat will allow herself to be sucked by the young of various other animals, and a foal which has lost its mother, has been suckled by a goat, placed on a barrel to facilitate the operation. As the butter of goat's milk contains a larger proportion of gelatine, and less oil than that of the cow, it is recommended by physicians as nearly equally light as ass's milk; it is the most prolific of all in curd, and forms excellent cheese; but it is an error to suppose that the parmesan (a skim-milk cheese) is made from it. Ewe's milk is gradually wearing out of use, though it makes excellent cheese, and some milking ewes as well as goats might be kept for that purpose, by those who have extensive upland grass-lands. The milk of the ass comes the nearest to that of the woman, and being the lightest of any is much recommended in pulmonary and hepatic affections. Soda water and warm cow's milk is taken as a substitute, and found almost equally light. The milk in universal use as an article of food in Britain is that of the cow.

6296. *Lactometers* for ascertaining the value of milk, relatively to butter and cheese, will be described among the utensils of the dairy in the succeeding section.

SECT. II. *Of the Dairy House, its Furniture, and Utensils.*

6297. *The properties requisite in a good milk-house* are, that it be cool in summer and moderately warm in winter, so as to preserve a temperature nearly the same throughout the whole year, or about 45 degrees; and that it be dry, so as to admit of being kept clean and sweet at all times. For these reasons a northern exposure is the best, and this as much under the shade of trees or buildings as possible; if it can be so situated that the sun can have no influence either on the roof or walls, so much the better. A well-constructed butter-dairy should consist of three apartments; a milk-house, a churning-house, with proper boiler, as well as other conveniences for scalding and washing the implements, and a room for keeping them in, and for drying and airing them, when the weather will not permit of its being done without doors. The cheese-dairy should likewise consist of three apartments; a milk-house, a scalding and pressing-house, and a salting-house. To these should be added a cheese-room or loft, which may with great propriety be made above the dairy. This is, however, generally separate from the dairy. But a milk-dairy requires only a good milk-house, and a room for scalding, cleaning, and airing the utensils.

6298. *A dairy for the private use of any farmer or family* need not be large, and may very economically be formed in a thick walled dry cellar, so situated as to have windows on two sides, the north and east in preference, for ventilation; and in order that these windows may the better exclude cold in winter, and heat in summer, they should be fitted with double sashes, and on the outside of the outer sash should be a fixed frame of close wire netting or hair cloth to exclude flies and other insects.

6299. *Of dairies for dairy farmers*, there are different sizes and shapes.

6300. *A dairy-house connected with a cow-house*, and mill for preparing food for the cows, churning, and washing the family linen, is thus arranged. (fig. 655.) The dairy

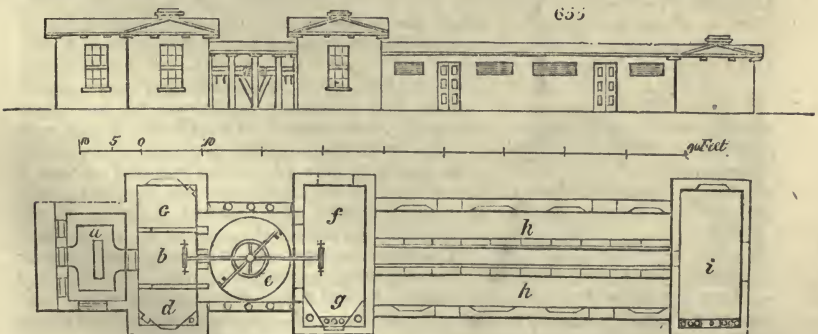

(a, b, c, d), is at the north end, has hollow walls, double doors, double sashed windows and an ice-house under. The milk room (a), is surrounded by milk coolers, and has a butter slab and jet in the centre. The jet is supplied from a cistern over the steaming,

house (*f, g*), to which the water is raised from a well by a forcing pump worked by the gin wheel. Besides supplying the jet, it furnishes, by cocks and pipes, water for the usual dairy purposes, the steaming or boiling of food for the cows, their drink, and washing out the cow-house, the washing machine, &c. The churning room (*b*), is separated from the milk-room by double doors, as is the latter from the cheese-room (*c*) and store closet (*d*). The gin wheel (*e*) is worked by one or two horses, or oxen or asses, according to the work to be done. The steaming and washing room (*f, g*) is a large roomy apartment properly fitted up, and furnished with two boilers, a machine for steaming cattle food, another for washing linen by steam; one impelled by the gin wheel operating on an axle with beaters or lifters (*fig. 656.*), and a cylinder of open spars, which turns round in a box of water for washing potatoes or other roots. The cow-house (*h h*) is calculated for forty cows to be fed from a broad passage in the centre. At the south end is a large apartment (*i*) open to the roof for hay, straw, green herbage for soiling, turnips and other food; and under it is an urinarium vaulted, and from which the liquid is drawn by a Buchannan pump (4154.) outside of the building, and some yards distant.

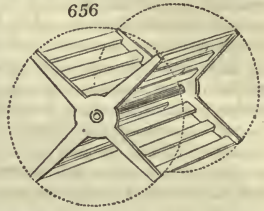

6301. *The dairy-house recommended by Dr. Anderson*, is surrounded by double walls, the inner of brick or stone, nine inches or a foot in thickness; and the outer about two feet distance, built of stone or turf; or a bank of earth faced with turf may be placed against the inner walls.

6302. *The size of the dairy-house* should vary according to that of the number of cows. Marshal found in Gloucestershire one for forty cows to be twenty feet by sixteen, and one for one hundred, thirty by forty. The North-Wiltshire dairy-rooms have in general, he says, outer doors, frequently opening under a pent-house or open lean-to shed; which is a good convenience, affording shade and shelter, and giving a degree of coolness to the dairy-room. In one instance he observed two doors: a common close-boarded door on the inside, and an open-paled gate-like door on the outside; giving a free admission of air in close warm weather, and, at the same time, being a guard against dogs and poultry. A convenience which, he thinks, would be an improvement to any dairy-room in the summer season. The inside wall may be seven or eight feet high in the sides, on which may be placed the couples to support the roof, and the walls at the gables carried up to the height of the couples. Upon these should be laid a roof of reeds, or thatch, that should not be less than three feet in thickness, which should be produced downward till it covers the whole of the walls on each side to the ground: but here, if thatch or reeds be not in such plenty as could be wished, there is no occasion for laying it quite so thick. In the roof, exactly above the middle of the building, should be placed a wooden pipe of a sufficient length to rise a foot above the roof, to serve occasionally as a ventilator. The top of this funnel should be covered, to prevent rain from getting through it, and a valve fitted to it, that by means of a string could be opened or shut at pleasure. A window also should be made upon one side for giving light, to be closed by means of two glazed frames, one on the outside, and the other on the inside. The use of this double sash, as well as the great thickness of the wall, and of the thatch upon the roof, are to render the temperature of this apartment as equal as possible at all seasons of the year, by effectually cutting it off from having any direct communication with the external air.

6303. *The dairy-house made use of by Wakefield of Liverpool*, contains three apartments; a milk-house, churning-room, and room for the utensils. In the milk-house, were the coolers; a slab for laying butter on after it is made up; cocks for drawing off the milk from the coolers; a large cock to throw water on the floor, which slopes a little from that part; cocks at the back part of the coolers, for letting in water; a door, latticed, and another door most commonly used, but pannelled. In the churning-room is a fire-place, a boiler, a large copper, also used when brewing. The room for drying or airing the utensils is also used occasionally as a laundry. Over the whole are apartments for the servants.

6304. *A very neat dairy for a private family* may be made under the shade of two or three tall trees, in the following manner:—Build the walls of bricks, and hollow in Silverlock's manner, by which every course of brick-work is laid on edge, and forms oblong

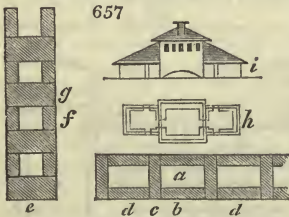

cavities (*fig. 657 a*), the bricks of the one course being laid alternately lengthways (*b*), and cross ways (*c*), and those of the next breaking joint with these, by the cross ones being placed on the middle of the long ones (*d*). The elevation of such a wall (*e, f, g*) should of course be founded on solid work, of breadth and thickness according to the height of the wall, and nature of the foundations. The plan of a dairy with such walls should contain the three usual apartments for milk, churning, and utensils (*h*), and should have double doors and win-

dows: the latter guarded by flywire. The elevation (*i*), may be of any style of simple architecture.

6305. *As a complete dairy on a large scale*, we submit the following. The plan (*fig. 658.*), is of an oblong form, and consists of the three usual principal apartments, enclosed by walls of four inches in thickness, and surrounded by a passage two feet



wide to the north, and three feet to the south, which is again surrounded by a nine inch wall. The passages communicate with the roof by covered openings, in the ridge of

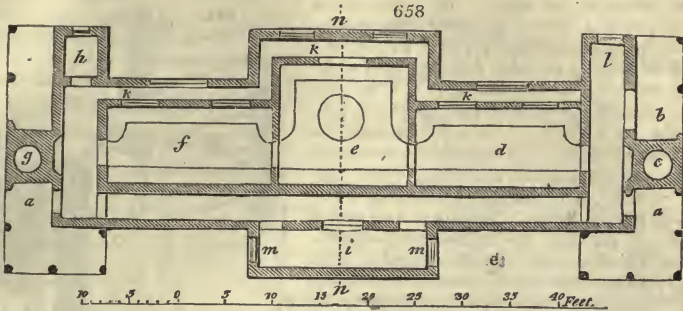

which and by the windows, ventilation is completely effected. In detail, the plan exhibits two principal entrance porches (a), back entrance (b), copper for heating water (c), churning-room (d), milk-room (e), utensils and cheese-press (f), boiler for heating milk (g), store closet or butter-room (h), cheese-room (i), passage surrounding the whole (k), water closet (l), and windows to cheese-room (m).

6306. A section (fig. 659.) taken across the milk-room (fig. 658 n n) exhibits the ventilating funnel in the roof (a), projecting eaves (b, c), cheese-room (d), passage on the north side (e), raised part of the roof for ventilation (f, g), fountain in the centre of the dairy (h), and south passage (i).

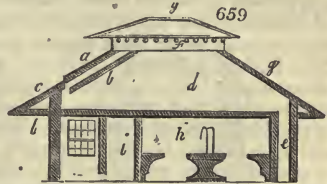

6307. The elevation (fig. 660.), presents a simple shed roof, varied, however, by projections and recesses: it presents no windows or doors to the south, and, therefore that side, if other circumstances permit, may be covered with vines or other fruit-trees, or with ornamental creepers.

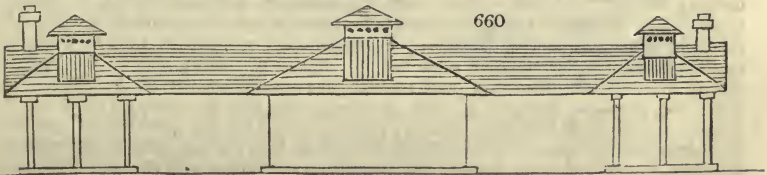

6308. The fixtures of the dairy are, in the scalding room, a copper boiler fixed over a fire-place, for boiling water to wash and scald the utensils; next, some benches and shelves in this room and the cheese-room; and a bench or table not more than two feet wide surrounding the milk-room. It is very desirable, also, that there should be a jet, or fountain, or pump, or spring, in the centre of the milk-room, in order to cool down the air in summer, and to supply clear water at a moderate temperature at all times.

6309. The utensils of the dairy are, pails for milking into; sieves of hair cloth, or silver-wire cloth for passing the milk through, to free it from hairs and other impurities; milk dishes, or coolers, for holding the milk till it throws up its cream; a cream-knife of ivory, for separating, and skimming dishes of willow or ivory for removing the cream; bowls and barrels for holding it, or other preparations of milk-churns, butter-makers, butter-prints; one or more tubs for hot or cold water, in which to immerse vessels that require extraordinary purification; and a portable rack for drying dishes in the open air. All these utensils are requisite where butter only is to be produced.

6310. The utensils requisite, if cheese is to be made, are, the cheese-tub, in which the curd is broken, and prepared for being made into cheese; the cheese-knife, generally a thin spatula of wood, but sometimes of iron, used for the purpose of cutting or breaking down the curd while in the cheese-tub. The cheese-cloth is a piece of thin gauze, like linen cloth, in which the cheese is placed in the press; the cheese-board is circular, and on it the cheeses are placed on the shelves of the cheese-room; their diameter must be somewhat less than that of the interior or hoop part of the vat. The vat is a strong kind of wooden hoop with a bottom, which, as well as the sides, is perforated with holes

to allow the whey to escape while the cheese is pressing: the size of vats must depend on that of the cheese and the number required, as of most of the other implements on the extent of the dairy. The cheese-press (fig. 661.), is a power generally obtained by a screw, though sometimes by a dead weight, and is used for forcing the whey from the curd while in the vat. The cheese-tongs is a wooden frame, occasionally placed on the cheese-tub, when the vat is set on it in order to drain the whey from the curd. To these implements some

662 add a lactometer, one kind of which (fig. 662.), is a glass tube a foot long, with a funnel at top. The upper two inches of the tube are marked in small divisions, and when the instrument is filled to the height of one foot with milk, the depth of cream it yields is noted by the gradations on the upper part. Another lactometer "for ascertaining the richness of milk from its specific gravity, by its degree of warmth taken by a thermometer, on comparing its specific gravity with its warmth," was invented by Dicus, of Liverpool, but never came into use. Another invention for the same purpose was made by Mrs. Lovi, of Edinburgh, in 1816. It consists of aerometric beads, by which the specific gravity of the milk is tried first when new-milked, and next when the cream is removed. When milk is tried as soon as it cools, say to 60°, and again, after it has been thoroughly skimmed, it will be found that the skimmed milk is of considerably greater gravity; and as this increase depends upon the separation of the lighter cream, the amount of the increase, or the difference between the specific gravity of the fresh and skimmed milk, will bear proportion to, and may be employed as a measure of, the relative quantities of the oily matter or butter contained in different milks. The specific gravity of skimmed milk depends both on the quantity of the saccharo-saline matters, and of the curd. To estimate the relative quantities of curd, and by that determine the value of milk for the purpose of yielding cheese, it is only required to curdle the skim-milk, and ascertain the specific gravity of the whey. The whey will, of course, be found of lower specific gravity than the skimmed milk, and the number of degrees of difference affords a measure of the relative quantities of the curd. According to this hypothesis, the aerometric beads may be employed to ascertain the qualities of milk, relatively both to the manufacture of butter and cheese. (*Trans. of the High. Soc. sect. v. part i.*)

6311. In *milk coolers and churns* there is considerable variation of form. Milk coolers are generally made of earthen ware or wood; but of late years they have been formed of lead, marble, slate, and cast iron. Their general form is round, and diameter from one to two feet; but in extensive dairies they are often made several feet or yards in length, and from two to three feet wide, with holes at one or more corners to admit the escape of the milk after the cream is removed. The safest dish is wood, though it requires most labor to keep it sweet; next is earthen ware or china, though on the leaden glaze of the former, the acid of the milk is apt to operate. Leaden dishes or troughs, though very general in Cheshire, are the most dangerous; and the objection to slate coolers is the joinings of the plates, which are always unsightly, imperfect, and liable to be operated on by the lactic acid. The annealed and tinned cast iron dishes of Baird's invention (in 1806), and which are now becoming universal in Scotland, are perhaps the best for such as do not chuse to go to the expense of China dishes. They are durable from the nature of the material, not liable to be broken by falls from being annealed, easily kept clean from being turned smooth, and also very economical, and said to throw up more cream from a given quantity of milk than any other.

6312. With respect to churns, besides the common *plunge and barrel churns*, there are various improved sorts. One of the best for using on a small scale is the patent box churn (fig. 663.); and on a large scale the plunge churn, worked by levers put in motion either by a man or horse. The Derbyshire churn (fig. 664.), which works on the principle of the barrel churn, is an excellent implement on a large scale. The bottom is a segment of a circle, and the advantage of the plan is, that when the butter is made, the lid (a) being removed the beaters (b) may be taken out at pleasure by with-

661

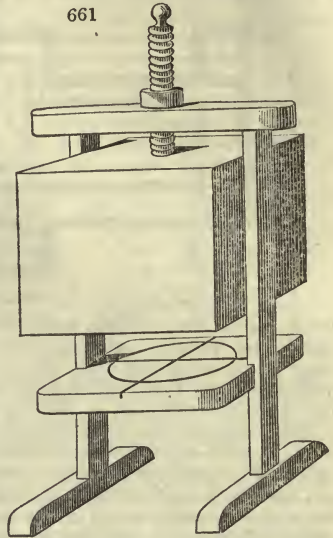

drawing the spindle (c) to admit the removal of the butter or the cleaning and scalding of the churn.

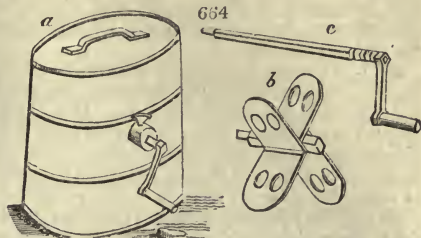
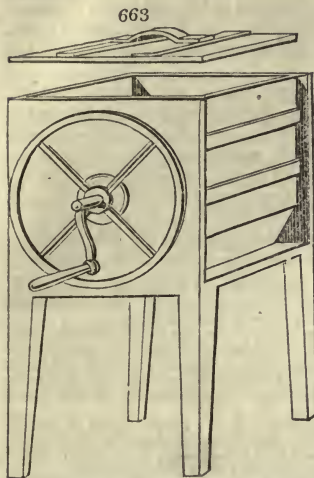

663. The Lancashire *plunge churn*, (fig. 665.) is a simple and effective implement, worked by the operator standing on the levers (a, b) throwing his whole weight alternately on each, so as by means of the line (c, d) connected with the churn staff to raise it and turn it round, and lower it and turn it round alternately.

664. The most exquisite cleanliness in the dairy, is an essential requisite, as to the walls, floor, shelves, benches, and in the different utensils. The milk

coolers and all the dishes in which milk is put, as well as the churn, must be scalded, scrubbed, rinsed and dried every time they are used. Scalding is less frequently requisite in the cheese utensils, but they also must be almost daily washed in hot water, dried, and aired. When any vessel becomes tainted with the acidity of milk, it operates like leaven, on what is put into it; if this taint cannot be removed by ordinary scalding, it may by boiling or immersing in water impregnated with alkali; but afterwards it must be well boiled; or a day or two immersed in pure water.

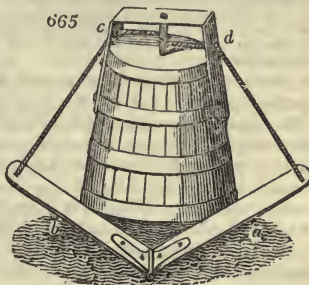

SECT III. Of Milking and the general Management of Milk.

665. The *times of milking* vary greatly in different districts. In most places cows are milked twice in twenty-four hours throughout the year; but in the best managed dairies where they are abundantly fed, they are milked at morning, noon, and the approach of night; the additional quantity thus obtained is very considerable, but according to the experiments of Parmentier it must be inferior in quality; for he found twelve hours requisite for the due preparation of the milk in the cow. Where quantity of milk or cheese is an object, three times milking must be decidedly preferable; but it is certain that in the best butter districts of England the cows are only drawn twice a day, between five and six o'clock morning and evening. Whatever may be the times of milking, it is essential that the milk be drawn off clear; for if the milk which the cow can be made to yield at the time be not completely taken away, the quantity left will be reabsorbed into the system, and no more will be generated than is necessary to supply the quantity actually drawn off.

666. The *operation of milking* is performed by men in many districts, but taking Britain generally it is more commonly the work of women. The milker, whether a man or woman, ought to be mild in manners and good tempered. If the operation be performed harshly, it becomes painful to the cow, who in this case often brings into action her faculty of retaining her milk at pleasure; but if gently performed, it seems rather to give pleasure, as is exemplified on a large scale in Tiviotdale, and Switzerland, where the cows come to be milked at the call of the milkers. Many instances have occurred, Dr. Anderson observes, in which cows would not let down a single drop of milk to one dairy-maid, which let it flow in abundance whenever another approached them; exhibiting unequivocal marks of satisfaction in the one case, and of sullen obstinacy in the other. For the same reason, when cows are ticklish, they should be treated with the most soothing gentleness, and never with harshness or severity; and, when the udder is hard and painful, it should be tenderly fomented with luke-warm water, and stroked gently, by which simple expedient the cow will be brought into

good temper, and will yield her milk without restraint. Lastly, as it sometimes happens that the teats of cows become scratched or wounded, so as to produce foul or corrupted milk, whenever this is the case, such milk ought on no account to be mixed with the sweet milk, but should be given to the pigs, without being carried into the milk-house; lest, by continuing there, it should taint the atmosphere, and consequently prove injurious to the rest of the milk.

6317. To promote cleanliness in regard to milking, cows are in some places curried, combed, brushed, and clothed like horses; before milking, their udders and teats are washed and dried, and their tails trussed up. It would be well if a part of this refinement were adopted in all dairies; that of using the comb and brush, and washing the udder, is indispensable in every establishment where clean milk is an object. According to Moubray snuff-takers, sluts, and daudles, are unfit to be dairy-women, and no milker should ever be suffered to enter the dairy in a dirty apron covered with hairs from the cow-house.

6318. The following aphorisms respecting the management of milk in the dairy are from the "Recreations" of Dr. Anderson, one of the most scientific writers on this subject.

1. Of the milk drawn from any cow at one time, that part which comes off at the first is always thinner, and of a much worse quality for making butter, than that afterwards obtained; and this richness continues to increase progressively to the very last drop that can be drawn from the udder.

2. If milk be put into a dish, and allowed to stand till it throws up cream, the portion of cream rising first to the surface is richer in quality, and greater in quantity, than that which rises in a second equal space of time: and the cream, which rises in the second interval of time, is greater in quantity, and richer in quality, than that which rises in a third equal space of time; that of the third is greater than that of the fourth, and so of the rest; the cream that rises continuing progressively to decrease in quantity, and to decline in quality, so long as any rises to the surface.

3. Thick milk always throws up a much smaller proportion of the cream which it actually contains, than milk that is thinner; but the cream is of a richer quality: and if water be added to that thick milk, it will afford a considerably greater quantity of cream, and consequently more butter than it would have done if allowed to remain pure; but its quality is, at the same time, greatly debased.

4. Milk, which is put into a bucket or other proper vessel, and carried in it to a considerable distance, so as to be much agitated, and in part cooled before it be put into the milk-pans to settle for cream, never throws up so much, or so rich cream, as if the same milk had been put into the milk-pans directly after it was milked.

6319. From these fundamental facts, the reflecting dairyist will derive many important practical rules. Some of these we shall enumerate, and leave the rest to be discovered. Cows should be milked as near the dairy as possible, in order to prevent the necessity of carrying and cooling the milk before it is put into the creaming dishes. Every cow's milk should be kept separate till the peculiar properties of each is so well known as to admit of their being classed, when those that are most nearly allied may be mixed together. When it is intended to make butter of a very fine quality, reject entirely the milk of all those cows which yield cream of a bad quality, and also keep the milk that is first drawn from the cow at each milking entirely separate from that which is last obtained, as the quality of the butter must otherwise be greatly debased, without materially augmenting its quantity. For the same purpose take only the cream that is first separated from the first drawn milk. Butter of the very best quality can only be economically made in those dairies where cheese is also made; because in them, the best part of each cow's milk can be set apart for throwing up cream, the best part of this cream can be taken in order to be made into butter, and the remainder, or all the rest of the milk and cream of the dairy, can be turned into cheese. The spontaneous separation of cream, and the production of butter, are never effected but in consequence of the production of acid in the milk. Hence it is that where the whole milk is set apart for the separation of cream, and the whole of the cream is separated, the milk must necessarily have turned sour before it is made into cheese; and no very excellent cheese can be made from milk which has once attained that state.

#### SECT. IV. Of Making and Curing Butter.

6320. The milk from which butter is to be made may either be put at once into the churn, and left there till it send up the cream; or it may be made to cream in milk dishes, and the cream alone churned. The last is generally considered the best mode, and in carrying it into effect, the milk being drawn from the cow, is to be strained into the creaming dishes, which should never be more than three inches deep, and of about a gallon and a half or two gallons in capacity. In general the best cream will be fit for removal in seven or eight hours, though for ordinary good butter it may stand twelve hours; but where the very best butter is wished, and such arrangements are formed as admit of converting the milk to cheese, or some other use while it is sweet, it may be separated after standing only two or three or four hours. In performing the operation, first pass the cream knife round the edges of the vessel, to separate the adhering stratum of cream, and then draw it to one side, lift it off with the skimming dish, and put it in the cream bowl to be carried to the cream barrel.

6321. Cream may be kept from three to seven days before it is churned. Where quantity more than quality is desired, the whole of the milk is churned, without separating any cream; the milk is kept in the churn or in large barrels for two or three days, till it begins to get sour. The operation of churning, where the cream and milk are both to agitate, is necessarily tedious and laborious; but a great weight of

butter is undoubtedly obtained, the quality and flavor of which will depend a good deal on the peculiar properties of the milk. The milk of Galloways, Ayrshires and Alderneys, so treated, makes excellent butter.

6322. *In the process of churning* great nicety is required; a regular stroke in plunge or pump churns, and a regular motion in those of the barrel or turning kind, must, if possible, never be deviated from. A few hasty irregular strokes or turns has been known to spoil what would otherwise have been excellent butter. Twamley (*Essays on the Dairy*) recommends the selection of a churner of a cool phlegmatic temper, of a sedate disposition and character; and advises never to allow any individuals, especially the young, to touch the churn without the greatest caution and circumspection. To those who have been accustomed to see cream churned without being properly prepared, churning may, perhaps, appear to be severe labor for one person in a large dairy; but nothing is more easy than the process of making butter, where the cream has been duly prepared.

6323. *The best time for making butter, during summer*, is early in the morning, before the sun acquires much power: and if a pump churn be used, it may be plunged a foot deep into a tub of cold water, where it should remain during the whole time of churning; which will very much harden the butter. During winter, from the equality of temperature, which (if it be properly managed) will generally prevail in a dairy, it will very rarely, if ever, be necessary to churn near the fire. Should any circumstance, however, require this, care should be taken not to churn so near the fire as to heat the wood; as it would impart a strong rancid taste to the butter. As soon as the butter is made, it must be separated from the milk, and be put into a clean dish; the inside of which, if of wood, should previously be well rubbed with common salt, to prevent the butter from adhering to it. The butter should then be pressed and worked with a flat wooden ladle or skimming-dish, having a short handle, so as to press out all the milk that may be lodged in the cavities of the mass. A considerable degree of dexterity, as well as of strength, is requisite in this manipulation: for, if the milk be not entirely removed, the butter will infallibly spoil in a short time; and, if it be much worked, the butter will become tough and gluey, which greatly debases its quality. In some places it is the practice to beat up the butter with two flat pieces of board, which may, perhaps, answer very well. In this operation, some persons pour cold water upon the butter, for the purpose of washing it: this practice, however, is not only useless, for the butter can be perfectly cleared of the milk without it; but it is also pernicious, and debases the quality of the butter in an astonishing degree. Nothing is so detrimental in a dairy, as water improperly used; which, if mixed in any way, either with milk or butter, tends greatly to debase the quality of the latter.

6324. *The making up of butter* is the next process. Before being sent to table or market, sweet or fresh butter is made up into various forms, sometimes in rolls or cylinders, six or eight inches long, and from half an inch to two inches in diameter, at other times in small round figures, or casts, with impressions in relief from butter moulds. When the butter is too soft for the last purpose, it may be put into small wooden vessels, which may be allowed to swim in a tub or cistern of cold water; or they may be set in an ice-house for an hour or two, or the water in which the small vessels float may be iced. At all events, whatever mode is adopted, no water ought to be allowed to touch the butter. When formed into the desired shapes it may be placed in dishes, and set in the margin of the central cistern of water till wanted.

6325. *In salting or curing butter* the use of wooden vessels is preferable. These should previously be rendered as clean and sweet as possible, well rubbed with salt, and the cavity between the bottom and sides filled in with melted butter. An excellent composition for preserving butter may be made, by reducing into a fine powder, and carefully mixing together, sugar and nitre, of each one part, and two parts of the best common salt. Of this composition, one ounce should be thoroughly mixed with every sixteen ounces of butter, as soon as the latter has been freed from the milk; and the butter must be immediately put into the firkin, being pressed so close, as to leave no air-holes, or any kind of cavities within it. The surface must be smoothed; and, if a day or two be expected to elapse before more can be added, the vessel must be closely covered up with a piece of clean linen, upon which should be laid a piece of wetted parchment, or (if this be not procurable) with a piece of fine linen dipped in melted butter, that is exactly fitted to the edges of the vessel, all round, so as to exclude the air as much as possible. When more butter is to be added, these coverings are to be removed; the butter is to be applied close upon the former layer, pressing it down, and smoothing it as before, till the vessel be full. The two covers are then to be spread over it with the greatest care; and a little melted butter is to be poured all round the edges, so as to fill up every part, and effectually to exclude the air. A little salt may then be strewed over the whole, and the cover be firmly fixed down. Butter thus cured does not taste well till it has stood at least a fortnight after it has been salted; but after that period, it acquires a rich marrowy taste, and will continue perfectly sweet in this climate for many years. As, however, its quality is liable to be impaired by being improperly treated while it is using, it will be necessary, when the firkin is opened, first to pare off a small portion of the whole surface, especially near the edges, in case the air should, by any accident, not have been entirely excluded. If it is to be quickly consumed, it may be taken up as it is wanted, without any other precaution than that of keeping it carefully covered up; but, on the contrary, if it is to be used very slowly, and if the person employed to take it up, be not very careful in closing it up each time with the covers, the part which is thus exposed to the air, will be liable to contract a small degree of rancidity. To prevent the occurrence of this inconvenience, when the vessel

is opened, a strong brine of common salt (strong enough to float an egg) should be poured, when cold, upon the surface of the butter; and although the quality of the latter will be slightly injured by the action of the water upon it, yet that is a much less evil, than the slightest rancidity would occasion.

6326. *When butter is to be exposed to the heat of a warm climate*, it should be purified by melting before it is salted and packed up. For this purpose, let it be put into a proper vessel, and this be immersed into another containing water. Let the water be heated till the butter be thoroughly melted: let it continue in this state for some time, when the impure parts will subside, leaving at the top a perfectly pure transparent oil. This, when it cools, will become opaque, and assume a color nearly resembling that of the original butter, being only somewhat paler, and of a firmer consistence. When this refined butter is become a little stiff, but while it is still somewhat soft, the pure part must be separated from the dregs, and be salted and packed up in the same manner as other butter; it will continue sweet much longer in hot climates, as it retains the salt better than in its original state. It may also be preserved sweet, without salt, by adding to it a certain portion of fine honey, perhaps one ounce to a pound of butter, and mixing them together thoroughly, so that they may be perfectly incorporated. A mixture of this sort has a sweet pleasant taste, and will keep for years without becoming rancid: there is no doubt, therefore, but that butter might thus be preserved in long voyages without spoiling.

6327. *As winter made butter* is mostly pale or white, and, at the same time, of a poorer quality than that made during the summer months, the idea of excellence has been associated with the yellow color: hence various articles have been employed in order to impart this color; those most generally used, and certainly the most wholesome, are the juice of the carrot, and of the flowers of the marigold, carefully expressed and strained through a linen cloth. A small quantity of this juice (and the requisite proportion is soon ascertained by experience) is diluted with a little cream, and this mixture is added to the rest of the cream when put into the churn. So small a quantity of the coloring matter unites with the butter, that it never imparts to it any particular taste.

6328. *The butter most esteemed in London* is that of Epping and Cambridge; the cows which produce the former feed during summer in the shrubby pastures of Epping forest, and the leaves of the trees, and numerous wild plants which there abound are supposed to improve the flavor of the butter. It is brought to market in rolls from one to two feet long, weighing a pound each. The Cambridgeshire butter is produced from the milk of cows that feed one part of the year on chalky uplands, and the other in rich meadows or fens; it is made up into long rolls like the Epping butter, and generally salted, not cured, before brought to market. By washing it, and working the salt out of it, the London cheesemongers often sell it at a high price for fresh Epping butter.

6329. *The Suffolk and Yorkshire butter* is often sold for that of Cambridgeshire, to which it is little inferior. The butter of Somersetshire is thought to equal that of Epping; it is brought to market in dishes, containing half a pound each, out of which, it is taken, washed, and put into different forms by the buttermen of Bath and Bristol. The butter of Gloucestershire and of Oxfordshire is very good; it is made up in half pound packs or prints, packed up in square baskets, and sent to the London market by waggon.

6330. *The butter of the mountains of Wales and Scotland*, and the moors, commons, and heaths of England is of excellent quality, when it is properly managed; and though not equal in quantity, it often is confessedly superior to that produced from the richest meadows. Bad butter is more frequently the result of mismanagement, want of cleanliness, and inattention, than of any other cause. Ireland would produce the finest butter in the empire, were it not for the intolerably filthy state of their cows, and the want of cleanliness in their dairies.

6331. *In packing fresh butter*, or butter salted only for immediate use, the leaves of cabbage, white beet, or of the garden orache (*Atriplex hortensis*) are to be preferred. The bottom of the basket should be bedded with a thick cloth, folded two or three times; then a thin gauze, dipped in cold water, spread over it, on which the prints or rolls of butter are to be placed, each with one or more leaves beneath, and smaller ones over it. The lowermost layer being adjusted, fold half of the gauze cloth over it, put in another layer in the same way, and then cover with the remainder of the gauze. The butter should be put into the basket, as well as taken from thence, without being touched.

6332. *Whey butter*, as its name implies, is butter made from the whey which is taken from the curd, after the milk is coagulated for the manufacture of cheese. It is chiefly made in those counties where cheese is manufactured, and where it forms no inconsiderable part of the profits of the dairy. In the county of Derby, more butter is said to be made from whey than from the cream of milk, or from milk churned altogether.

6333. *Whey is divided into two sorts*, green and white, the former escaping readily from the curd, while the latter is freed from it by means of pressure. "There are different methods of extracting the whey. In some dairies the whole whey, when taken from the cheese tub, is put into pails or other vessels, where it remains for about twenty-four hours; when it is creamed, and the whey is applied to the use of calves and pigs, which are said to thrive as well on it, after the cream has been taken from it as before. The cream, when skimmed off the whey, is put into a brass pan and boiled, and afterwards set in pans or jars, where it remains till a sufficient quantity for a churning be procured, which, in large dairies, happens generally once, but sometimes twice in the week."

6334. *Butter forming an important article of commerce as well as food*, the legislature has passed various statutes respecting its package, weight, and sale. The principal of these are the 36th and 38th of Geo. III.

#### SECT V. *Of the Process of Cheese-making.*

6335. *The production of cheese* includes the making of rennet, the selection of a coloring matter, the setting of the curd, and the management of the cheese in the press.

6336. *The milk fresh drawn from the cow is to be immediately strained into the dishes or shallow troughs, if these are used, in order to promote cooling, as the surest guard against fermentation. The same object may be attained by repeatedly drawing off the milk from the coolers, and pouring it back again.*

6337. *To understand what rennet is and its uses it is necessary to premise that milk is no sooner taken into the stomach, than it becomes curdled by the operation of the gastric juice, as every one who has seen much of infant children must have observed. What is called rennet is nothing more than the stomach of an animal in which the gastric juices are preserved by means of salt. The application of any kind of acid will cause milk to coagulate, as well as the infusion of several plants, as ladies' bedstraw (*Galium verum*), butter-wort (*Pinguicula vulgaris*), and others. With the former plant the Jews coagulate the milk for all their cheese; the Mosaic law prohibiting them to mingle meat with milk, and rennet they consider as meat. The maw or stomach of ruminating animals, which admit of obtaining the gastric juice in a less mixed state than those of others, and chiefly of a young calf that has been killed before the digestion is perfected, is almost universally preferred as rennet. This bag or maw is cleaned and salted in different ways in different districts; but the following method described by Marshal in his *Rural Economy of Norfolk*, is considered as one of the best. "Take a calf's bag, maw, or stomach; and having taken out the curd contained therein, wash it clean, and salt it thoroughly inside and out, leaving a white coat of salt over every part of it. Put it into an earthen jar, or other vessel, and let it stand three or four days; in which time it will have formed the salt and its own natural juice into a pickle. Take it out of the jar, and hang it up for two or three days, to let the pickle drain from it. Re-salt it, place it again in a jar, cover it tight down with a paper, pierced with a large pin, and in this state let it remain till wanted for use. In this state it ought to be kept twelve months; it may, however, in case of necessity, be used a few days after it has received a second salting; but it will not be so strong as if kept a longer time."*

6338. *In order to prepare this rennet for use, Marshal gives the following directions; "Take a handful of the leaves of sweet-briar, the same quantity of the leaves of the dog rose, and the like quantity of bramble leaves; boil them in a gallon of water, with three or four handfuls of salt, about a quarter of an hour; strain off the liquor, and, having let it stand till perfectly cool, put it into an earthen vessel, and add to it the maw, prepared as above. To this is added, a good sound lemon, stuck round with about a quarter of an ounce of cloves, which give the rennet an agreeable flavor."*

6339. *The strength of the rennet thus prepared will increase in proportion to the length of time during which the bag remains in the liquor; the quantity to be used for the purpose of coagulating milk can, therefore, be ascertained only by daily use and occupation. In general, however, it may be stated, upon the average, that somewhat less than half a pint of wine measure, will suffice for fifty gallons of milk, for which quantity, in Gloucestershire, the practice is to employ about one third of a pint. Throughout the whole process of preparing and preserving rennet, too much attention cannot be given to its cleanliness and sweetness; for if it be kept too long, so as to become foul or tainted, the cheese will invariably become affected by it, and will prove unfit for use.*

6340. *In Holland a small quantity of the muriatic acid is used instead of rennet; and it is the use of this article which gives to the Dutch cheese that pungent relish, which induces so many persons to prefer it.*

6341. *Coloring matter.* As cheese in its native state, that is, such as is well manufactured, being put together in proper time, the milk being of a proper degree of warmth, and in all other respects properly pressed, salted, and dried, is uniformly of a bright yellow cast, the idea of excellence is generally attached to cheese of such a color. Hence it has become necessary for the dairyman, who would dispose of his cheese to advantage, to impart a light yellow orange color to it by artificial means. Formerly, turmeric, marigolds, hawthorn buds, and other vegetables, were employed for this purpose; but these have long since been rejected for the *Spanish Arnotto*, which is unquestionably the best ingredient of the kind that can be used for the coloring of cheese. It is a preparation of the *roucon* or arnotto tree (*Bixa orellana*, Lin. fig. 204.), which is a native of America. The red pulp, that covers the seeds of this tree, is suspended in hot water, and allowed to subside, and when dry, is formed into cakes or balls, which are further set aside, until they become completely dry and firm. One ounce of this substance, when genuine, will be sufficient to color an hundred weight of cheese; and this is the common allowance in the county of Gloucester; in Cheshire, the weight of a guinea and a half, is considered to be sufficient for a cheese of sixty pounds weight. The usual mode of applying the arnotto is, to dip a piece, of the requisite size and weight, in a bowl of milk, and rub it on a smooth stone, until the milk assume a deep red color. This infusion is to be added to the milk, of which cheese is intended to be made, in such a quantity as will impart to the whole a bright orange color, which will

become the deeper in proportion to the age of the cheese. The mixing of the arnotto in no respect affects either its taste or smell.

6342. *In the county of Cheshire*, however, a somewhat different practice obtains. There, when the coloring matter is wanted, it is usual to tie up as much of the substance as may be deemed sufficient, in a linen rag; and putting it into half a pint of warm water, to let it stand over night. In the morning, immediately before the milk is coagulated, the whole of this infusion is mixed with it in the cheese-tub, and the rag is dipped in the milk, and rubbed on the palm of the hand, until all the coloring matter is completely extracted. A more simple method is directed by Parkinson: "Take," says he, "a piece about the size of a hazel nut, put it into a pint of milk the night before you intend to make cheese, and it will dissolve. Add it to the milk at the time the rennet is put in. The quantity will suffice to color a cheese of twenty pounds weight." (*Parkinson on Live Stock*, vol. i. p. 62.)

6343. *Setting the curd.* The proper season for making cheese is from the beginning of May till the close of September, or, in favorable seasons till the middle of October. Very good cheese, however, may be made in winter, provided the cows be well fed. A certain elevation of temperature is requisite to the coagulation of milk, and it may naturally be supposed to be nearly that of the stomachs of milk-taking animals. Marshal is of opinion that from 85 to 90 degrees of heat, and two hours of time are the fittest for coagulation. Climate, season, weather, and pasture may require that these limits should sometimes be violated. Milk produced from poor clays will require to be coagulated at a higher temperature than that which is procured from rich pastures. In some dairies the milk is heated to the proper temperature; but the most approved practice is to mix boiling water in such a proportion as shall render the milk of a proper degree of heat to receive the rennet; this the thermometer should be used to determine. In hot weather the milk in the cows' udders is liable to become very much agitated by their running about, or being driven to too great a distance: so that if rennet be put to it in this state, the curd, instead of coming in one or two hours, will require three, four, or five hours, and will be so spongy, tough, and in every respect so imperfect, as to be scarcely capable of being confined in the press or vat; and when released from the press, it will heave or split, and be good for little. Whenever therefore cows are discovered to be in this state, which, perhaps, can scarcely be avoided during very hot weather, where cows are pastured abroad, in unsheltered grounds, or where water is not within their reach; it will be advisable to add some cold fresh spring water to the milk as soon as it is brought into the dairy. The quantity to be mixed, in order to impart the proper degree of heat, can in this case only be regulated by experience and the use of the thermometer. The effect of the water thus added, will in both cases be, to make the rennet take effect much sooner, and consequently to accelerate the coagulation of the milk.

6344. *The proportion of rennet and time requisite for coagulation* have been already mentioned (6339. 6343.); too much rennet ought not to be put in, otherwise the cheese will be ready to heave, as well as become rank and strong; the same effects will also be produced if the rennet be made with bad or foul materials, or if it be too strong to operate in the given time (two hours). During the process the milk ought to be covered so as not to lose more than five or seven degrees of its original heat. One or two handfuls of salt added previously to mixing the rennet will promote coagulation. Some put in a bowl, which is an absurd ancient custom, is injurious rather than useful.

6345. *When the coagulation has taken place*, the curd is broken or cut with a cheese knife, which causes the whey to rise through the incisions, and the curd sinks with more ease. After a short time the cutting is repeated, still more freely than before; and is continued until the curd is reduced to small uniform particles. This operation will require about three quarters of an hour: the cheese tub is again covered with a cloth, and is allowed to remain for the same time. When the curd has sunk to the bottom of the vessel, the whey is taken off by the hand, or by means of a skimming-dish; another quarter of an hour should now be allowed for the curd to settle, drain, and become solid, before it is broken into the vat, as it prevents the fat from being squeezed out through the fingers, and of course contributes to improve the quality of the cheese. Sometimes in addition to the skimming-dish, a semicircular board and weight, adapted to the size of the tub, are employed. The curd is again cut as before, in order to promote the free separation of the whey, and pressure is again applied till it be wholly drawn off. Great attention is requisite in conducting this part of the business; and if any particles of slip curd should be seen floating in the whey, it ought to be carefully laded off with the whey; as it will not incorporate with the solid curd, but, dissolving in the cheese, causes whey-springs, as already mentioned, and materially impairs its soundness. If the whey be of a green color, when loaded or pressed out, it is a certain criterion that the curd has been properly formed; but if it be of white color, it is equally certain that the coagulation is imperfect, the cheese will be sweet, and of little value, and much valuable caseous matter will be completely thrown away. In the counties of Norfolk and Suffolk, the cheese manufacturers have recourse to a somewhat different method for extracting the whey, which is worthy of notice: when they think the milk sufficiently coagulated, they lay a strainer in a basket made for the purpose; into which they put the



curd, and suffer it to remain there for some time to drain, before they break the curd. When the curd is sufficiently drained, it is put into two or three separate vessels, and is broken with the hand as small as possible. During this part of the process, salt is scattered over the curd, and intimately mixed with it; the proportion, however, has not been correctly ascertained, and is regulated by experience.

6346. *Management in the press.* The breaking and salting completed, a cloth is spread over the cheese vat, and the broken curd being packed into it, and covered up with the cloth, a smooth round board is laid over the vat; which is usually filled to the height of one inch above the brim, to prevent the curd from shrinking below its sides, when the whey is squeezed out. The whole is then put into a press for two hours, and as it is of the utmost importance that every drop of whey should be expressed, skewers are thrust into the cheese through the holes in the lower part of the vat to facilitate its escape. The two hours expired, the cheese is taken out, and put into a vessel of warm or hot whey for an hour or two, in order to harden its skin. On taking the cheese out of the whey it is wiped dry, and when it has become cool, is wrapped in a clean dry cloth, of a finer texture, and again submitted to the press for six or eight hours. The cheese is now turned a second time, and is taken to the salting room, where it is rubbed on each side with salt; after which it is wrapped in another dry cloth, of a finer texture than either of the preceding cloths, and is again pressed for twelve or fourteen hours; if any edges project these are pared off, and the cheese being laid upon a dry board, is turned every day. In the salting room cheese should be kept warm until it has had a sweat, or has become regularly dry and somewhat stiff; as it is warmth that ripens cheese, improves its color, and causes it when cut to have a flakey appearance, which is the surest sign of superior excellence.

6347. *Management in the cheese-room.* After the processes of salting and drying are completed, the cheeses are deposited in the cheese-room or loft, which should be airy and dry; but on no account should hard and soft cheeses be placed in the same room, for the dampness or moisture arising from the latter, will cause the hard cheese to chill, become thick-coated, and often spotted. Throughout the whole process of cheese-making, the minutest attention will be requisite: for if the whey be imperfectly expressed, or the rennet be impure, or the cheese be not sufficiently salted, it will become rank and pungent. For this defect there is no remedy. The imperfect separation of the whey will cause cheese to heave or swell, as well as to run out at the sides. In order to prevent as well as to stop this heaving, the cheese must be laid in a moderately cool and dry place, and be turned regularly every day. If the heaving be very considerable, the cheese must be pricked on both sides in several places, particularly where it is most elevated, by thrusting a skewer into it: by this pricking, though the heaving will not be altogether prevented, a passage will be given to the confined air, the heaving or swelling will consequently be considerably reduced, and the cavities of the cheese will be less offensive to the eye. Another remedy for *heaving* in cheese, consists in applying a composition of nitre, and bole armeniac, which is vended in the shops under the name of *cheese-powder*. It is prepared by mixing one pound of saltpetre with half an ounce of bole armeniac thoroughly together, and reducing them to a very fine powder. About a quarter of an ounce of this is to be rubbed on a cheese, when put a second and third time into the press, half on each side of the cheese at two different meals, before the salt is rubbed on, that the cheese may be penetrated with it. This preparation is very binding, and sometimes proves serviceable, but the nitre is apt to impart an acid taste; and if too much be applied, and the cheese should be exposed to too great heat, the quantity of air already confined in it will be increased by fermentation, and the cheese will swell much more than it would, if no powder had been rubbed in. The greatest care, therefore, will be necessary whenever this remedy is adopted.

6348. *Hard and spoiled cheese* may be restored in the following manner: take four ounces of pearl-ash, and pour sweet white wine over it, until the mixture ceases to effervesce. Filter the solution, dip into it clean linen cloths, cover the cheese with them, and put the whole into a cool place, or dry cellar. Repeat this process every day, at the same time turning the cheese, and, if necessary, continue it for several weeks. Thus the hardest and most insipid cheese, it is affirmed, has frequently recovered its former flavor.

#### SECT. VI. Catalogue of the different Sorts of Cheeses and other Preparations made from Milk.

6349. *Of cheeses*, we shall first enumerate the British sorts, and next, those peculiar to foreign countries: the description of each will be such as to enable any ingenious dairymaster to imitate them.

6350. *The brick-bat cheese* is so named from the form of the mould; it is formed of new milk and cream in the proportion of two gallons of the former to a quart of the latter. It is principally made in Wiltshire in the month of September, and should not be cut until it is twelve months old.

6351. *Cheddar cheese*, so named from the vale of that name in Somersetshire, where it is exclusively made. It is made in cheeses about thirty pounds each, which have a spongy appearance, and the eyes are filled with a limpid and rich, but not rancid oil.

6352. *Cheshire cheese* is in universal esteem; it is made from the whole of the milk and cream, the

morning's milk being mixed with that of the preceding evening, previously warmed. The general weight is sixty pounds each cheese.

6353. *Dunlop cheese*, so named from the parish of Dunlop in Ayrshire, where it was originally made; the whole of the cream goes with the curd; the cheeses are from twenty to sixty pounds weight, and no coloring matter is used. A cheese in every respect similar is made in Derbyshire, excepting that these last are generally of a smaller size.

6354. *Gloucester cheese* is in very considerable demand from its mild taste, which suits most palates, especially those of the young and of simple habits: there are two kinds, double and single, the first made from the milk and cream, and the latter with the milk deprived of about half the cream: the latter are of course the least valuable; but as they may be often mistaken for the former, upright dairymen, Marshal observes, impress a heart-shaped stamp upon them to distinguish them from the former. They are made of various sizes, from twenty to seventy, or even eighty pounds weight, but generally from fifty to sixty pounds.

6355. *Green, or sage cheese*, is made by steeping over night in a proper quantity of milk, two parts of sage, one part of marigold leaves, and a little parsley, after they have been bruised. On the following morning, the greened milk is strained off, and mixed with about one third of the whole quantity intended to be run or coagulated. The green and white milks are run separately, the two curds being kept apart until they be ready for vatting: these may be mixed, either evenly and intimately, or irregularly and fancifully, according to the pleasure of the manufacturer. The management is the same as for common cheese. Green cheeses are made in the vale of Gloucester, as also in Wiltshire.

6356. *Lincolnshire cheese* is made by adding the cream of one meal's milk to that which comes immediately from the cow; it is pressed gently two or three times, and is turned for a few days previously to being used. It is chiefly made in spring, but the richest is that made in autumn. It will not keep above three months.

6357. *Norfolk cheese* is made from the whole of the milk and cream; the size is from thirty to fifty pounds; it is generally colored yellow, and is reckoned a good keeping cheese.

6358. *Soft, or slip-coat cheese*, is made from new milk hot from the cow, and the afterings; and what is required to make one pound of butter, will, in general, make one pound of cheese: this is a small soft rich cheese, which must be used immediately.

6359. *Stilton cheese*, which, from its peculiar richness and flavor, has been called the parmesan of England, is made in the following manner:—the night's cream is put to the morning's milk, with the rennet; when the curd is come, it is not broken as is usual with other cheese, but is taken out whole, and put into a sieve to drain gradually; while draining, it is gently pressed till it becomes firm and dry, when it is placed in a vat, a box made exactly to fit it; as it is so extremely rich, that without this precaution, it is apt to bulge out, and break asunder. It is afterwards kept on dry boards, and turned daily, with cloth binders round it, which are tightened as occasion requires. After being taken out of the vat, the cheese is closely bound with cloth till it acquires sufficient firmness to support itself: when these cloths are removed, each cheese is brushed once every day for two or three months, and if the weather be moist, twice every day; the tops and bottoms are treated in a similar manner daily before the cloths are taken off. Stilton cheese derives its name from the town where it is almost exclusively sold; it is made principally in Leicestershire, though there are also many who manufacture it in the counties of Huntingdon, Rutland, and Northampton. Sometimes the cheeses are made in a net, resembling a cabbage net, which gives them the form of an acorn, but these are neither so good nor so richly flavored, as those made in vats, having a thicker coat, and being deficient in that mellowness which causes them to be in such general request. (*Bath Papers*, vol. iii. p. 152, 153.) Stilton cheese is not reckoned to be sufficiently mellow for cutting, until it is two years old, and is not saleable unless it is decayed, blue, and moist. In order to mature them the more rapidly, it is a frequent practice to place the cheeses in buckets, which are covered over with horse-dung. Wine is also reputed to be added to the curd, in order to accelerate the ripening of the cheese.

6360. *Cottenham cheese*, from the town of that name in Cambridgeshire, is a thicker kind of cream cheese than the Stilton; its superior delicacy and flavor are attributed to the fragrant nature of the herbage on the commons on which the cows are pastured, and according to Professor Martyn, to the prevalence of *Poa aquatica* and *pratensis*.

6361. *Suffolk or skim cheese* is made of skimmed milk; it forms a part of every ship's stores, not being so much affected by heat as richer cheese, nor so liable to decay in long voyages.

6362. *Wiltshire cheese* is made of new milk coagulated as it comes from the cow, sometimes a small quantity of skimmed milk is added. In some dairies it is manufactured in winter as well as summer; in the former case it is liable to become scurfy and white coated; the last of which defects is frequently concealed by a coat of red paint.

6363. *Of foreign cheeses*, the most common is the *Dutch cheese*; this is prepared much in the same manner as the Cheshire cheese, excepting that muriatic acid is used instead of rennet, which renders it pungent, and preserves it from mites; that of Gouda is preferred.

6364. *Parmesan cheese* was formerly supposed to be made from the milk of goats, but it is merely a skim-milk cheese, the curd hardened by heat, well salted, pressed, and dried, long kept, and rich in flavor from the rich herbage of the meadows of the Po, where the cows are pastured.

6365. *The process*, according to Pryce, (*Bath Papers*, vol. vii.) is as follows:—the evening's milk, after having been skimmed in the morning, and standing till ten o'clock, and the morning's milk skimmed about two hours after it is drawn from the cow, are mixed together. The mixture is then suspended in a copper cauldron over a wooden fire (*fig. 33.*), and frequently stirred till it attains about 82° of Fahrenheit; the rennet is then put in, and the copper being removed from the fire, the coagulation quickly takes place, and the curd is afterwards worked with a stick till it is reduced to a small grain. The whey now occupies the surface, and a part of it being taken out, the cauldron is again turned over the fire, and its contents brought to nearly a boiling heat. A little saffron is now added to impart color, the whole being all the while well stirred, and the superintendent examining it from time to time with his finger and thumb, to ascertain the exact moment when the curd shall have become sufficiently solid. When this is the case, the cauldron is removed from the fire, and the curd allowed to subside; three fourths of the whey is then drawn off, water poured round the bottom of the cauldron outside to cool it, so as to admit of a cloth being passed below the curd, which is thus brought up and placed in a tub to clear. When drained, it is put into a wooden hoop, and about half a hundred weight laid on it for half an hour; the cloth is then removed, and the cheese being replaced in the hoop is laid on a shelf; here it remains for two or three days, at the end of which, it is sprinkled over with salt; this sprinkling is repeated every second day for about thirty days if it be summer, and for about forty or fifty-five days if it be winter, after which, no further attention is required. The best Parmesan cheese is that which has been kept for three or four years, but none is ever carried to market for sale, until it has been kept at least six months.

6366. *Swiss cheese* is of several varieties, mostly of skimmed or partially skimmed milk, and manufactured like the Parmesan. Its varied and rich flavor is more owing to the herbage of the pastures, than the mode of making; and some sorts, as the Gruyère

(so called from the bailiwick of that name in the canton of Fribourg), are flavored by the dried herb of *Melilotus officinalis* (fig. 46.) in powder. Gruyère cheeses weigh from forty to sixty pounds each, and are packed in casks containing ten cheeses each, and exported to the most distant countries. This cheese requires to be kept in a damp place, and should frequently be washed with white wine, to preserve it from the depredations of insects. Neufchâtel is celebrated for a very fine sort of cheese made there, which in shape resembles a wash-hand ball.

6367. *Westphalia cheese* is of the skim-milk kind, and of a different character from any of those hitherto described. The cream is allowed to remain on the milk till the latter is in a sub-acid state; it is then removed, and the milk placed near a fire spontaneously to coagulate. The curd is then put into a coarse bag, and loaded with ponderous stones to express the whey; in this dry state it is rubbed between the hands, and crumbled into an empty clean milk vat, where it remains from three to eight days according as the cheese is intended to be strong or mild. During this part of the process, which is called mellowing, the curd undergoes the putrid fermentation, and acquires a coat or skin on the top, before it is taken out of the vessel, and kneaded into balls or cylinders with the addition of a considerable portion of carraways, salt, and butter; or occasionally a small quantity of pounded pepper and cloves. When over-mellowed a third part of fresh curds, likewise crumbled into small pieces, is superadded, to prevent or correct its putrid tendency. As the balls or cheeses do not exceed three or four ounces each in weight, they soon dry in the open air, and are then fit for use. When nearly dry they are sometimes, for the palate of epicures, suspended in a wood fire chimney, in a net, for several weeks or months; and both their taste and flavor are said to be remarkably improved, whether kept in a dry air, or subjected to the action of smoke. This sort of cheese, M. Hochheimer, who describes it, affirms to be preferable to the Dutch, Swiss, and even Parmesan cheese. It is sometimes to be had in London, but is not very common.

6368. *Potatoe cheese* is a German manufacture, of which there are three sorts. One of the best is thus prepared. Select mealy potatoes, and only half dress them in steam, for by bursting their flavor and efficacy are diminished. Peel them, and then grate or beat them into a fine pulp. To three parts of this mass add two parts of sweet curd, knead and mix them, and allow them to stand three days in warm, and four or five days in cold weather; form into small pieces like the Westphalia cheeses, and dry in the same manner. A still better sort of potatoe cheese is formed of one part of potatoes, and three of the curd of sheep's milk. This sort is said to exceed in taste the best cheese made in Holland, and to possess the additional advantage that it improves with age, and generates no vermin.

6369. *The preparations of milk*, which can neither be included under butter nor cheese, are various, and constitute a class of wholesome luxuries or rural drinks. We shall do little more than enumerate them, and refer for further details to the cookery books.

6370. *Curds and whey* is merely coagulated new milk stirred up, and the curd and whey eaten together with or without sugar and salt.

6371. *Curds and cream*; here the whey is removed and cream substituted with or without sugar. The milk coagulated is often previously skimmed.

6372. *Sour cream*; cream allowed to stand in a vat till it becomes sour; when it is eaten with fresh cream and sugar, or new milk and sugar, and is found delicious.

6373. *Corstorphin cream*, so named from a village of that name two miles from Edinburgh, from which the latter city is supplied with it. The milk of three or four days is put together with the cream, till it begins to get sour and coagulated, when the whey is drawn off and fresh cream added. It is therefore simply *sour curd and fresh cream*; it is eaten with sugar as a supper dish, and in great repute in the north.

6374. *Devonshire cream*, is a term applied in the county of that name, sometimes to sour curd, and sometimes to sour cream; in either case mixed with new milk or fresh cream, and eaten with sugar like the Corstorphin cream.

6375. *Clotted cream*. The milk when drawn from the cow is suffered to remain in the coolers till it begins to get sour and the whole is coagulated. It is then stirred, and the whey drawn off, or the cream (now in clots among the curd) and the curd removed.

6376. *Hatted kitt*, a gallon of sour butter-milk is put in the bottom of the milk pail, and a quart or more of milk drawn from the cow into it by the milk-maid. The new warm milk as it mixes with the acid of the sour milk, coagulates, and being lighter rises to the top and forms a creamy scum or hat over the other, whence the name. This surface stratum is afterwards taken off, and eaten with sugar.

6377. *Milk syllabub* is formed in a similar manner over a glass or two of wine; and the whole is then eaten with sugar. Both sorts may be formed by those who have no cow, by warming the sweet or new milk, and squirting it into the wine or the sour milk.

6378. *Skim-milk*, is milk from which the cream has been removed; when this has been done within twelve or fifteen hours from the time of milking, it is sweet and wholesome, and fit either for being heated or coagulated, in order to make cheese, &c., or used as it is with other food; but if allowed to remain twenty or thirty hours it becomes sour, coagulates spontaneously, the whey separates from the curd, and if it remain a certain period, generally three weeks longer in a warm temperature, the vinous fermentation takes place, and a wine or a liquor from which ardent spirit may be distilled is produced.

6379. *Butter-milk*, is that which remains in the churn after the butter has been taken off. When butter has been made from cream alone, it is seldom of much value; but where the whole milk has been churned, and no water poured in during the process, it is a very wholesome cooling beverage. Some prefer it when it has stood a few days and become sour. In England it is chiefly given to pigs, but in Ireland it forms a very common diluter to porridge, potatoes, oat cakes, pease cakes, and other food of the laboring classes, and especially of the farm servants. In Scotland the same thing used formerly to be the case, but the practice there has within the last twenty years become nearly the same as in England; in the Orkney islands, and other northern parts of Britain, as well as in Ireland. Butter-milk is sometimes kept till it undergoes the vinous fermentation, when it is used to procure intoxication.

6380. *Whey*, when new and of a pale green color, forms an agreeable beverage, and with oatmeal makes an excellent gruel or porridge. Left till it gets sour, it undergoes the vinous fermentation as readily as butter-milk; and man, who in every state of civili-

zation feels the necessity of occasionally dissipating the cares of his mind, when he cannot find tobacco, opium, malt liquors, or ardent spirit, has recourse to sour whey.

---

CHAP. VI.

*The Sheep.* — *Ovis aries*, L.; *Mammalia Pecora*, L., and *Ruminaleæ*, Cuv. *Brevis*, Fr.; *Schaf*, Ger.; *Oveja*, Span. and *Pecora*, Ital.

6381. *The sheep* is an inhabitant of every part of the globe, from Iceland to the regions of the torrid zone. The varieties of form and clothing necessary to fit it for existing in so many climates are of course numerous. In most of these countries it is cultivated for its wool or flesh, and in many for both; but it is most cultivated in Europe, and especially in France, Spain, and Britain. In the latter country its culture has attained an astonishing degree of perfection. Besides the *O. aries*, or common sheep, there are three other species, the *O. Ammon* or Siberian sheep; the *Pudu* or South American, and the *Strepsiceros* or Cretan sheep. By some these are considered mere varieties. The Cretan and Siberian are cultivated in Hungary and Siberia.

6382. *The common sheep in a wild state* prefers open plains, where it herds together in small flocks, which are in general active, swift, and easily frightened by dogs or men. When completely domesticated, the sheep appears as stupid as it is harmless; it is characterised by Buffon as one of the most timid, imbecile, and contemptible of quadrupeds. When sheep, however, have an extensive range of pasture, and are left in a considerable degree to depend on themselves for food and protection, they exhibit a more decided character. A ram has been seen in these circumstances to attack and beat off a large and formidable dog, and even a bull has been felled by a stroke received between his eyes as he was lowering his head to receive his adversary on the horns and toss him in the air. Sheep display considerable sagacity in the selection of their food; and in the approach of storms, they perceive the indications with accurate precision, and retire for shelter always to the spot which is best able to afford it. The sheep is more subject to disorders than any of the domesticated animals; giddiness, consumption, scab, dropsy, and worms frequently seizing upon and destroying it. Of all disorders the most fatal is owing to vast numbers of worms of the genus *fasciola*, which are found in the liver and gall-bladder. They are of a flat form, of an oval shape, with slightly pointed extremities, and bear a general resemblance to the seeds of a gourd. The fly is another formidable enemy, and is often fatal in the course of twenty-four hours, breeding within the skull of the animal. To extricate the sheep from this danger, the French shepherds apply the *trephine* instrument, without the smallest hesitation, and with the greatest dispatch and success.

6383. *Of all the domestic animals of Britain*, Brown observes, *sheep are of the greatest consequence*, both to the nation and to the farmer; because they can be reared in situations, and upon soils, where other animals would not live; and, in general, afford greater profit than can be obtained either from the rearing or feeding of cattle. The very fleece, shorn annually from their backs, is of itself a matter worthy of consideration, affording a partial return not to be obtained from any other kind of stock. Wool has long been the staple commodity of this island, giving bread to thousands who are employed in manufacturing it into innumerable articles for home consumption, and foreign exportation. In every point of view, sheep husbandry deserves to be esteemed as a chief branch of rural economy, and claims the utmost attention of agriculturists. For many years back, it has been studied with a degree of diligence and assiduity not inferior to its merits; and the result has been, that this branch of rural management has reached a degree of perfection favorable to those who exercised it, and highly advantageous to the public.

SECT. I. *Of the Varieties of Sheep.*

6384. *The varieties of the O. aries*, or common sheep, dispersed over the world are, according to Linnæus, the hornless, horned, blackfaced, Spanish, many-horned, African, Guinea, broad-tailed, fat-rumped, Bucharian, long-tailed, Cape, bearded, and morvant; to which some add the Siberian sheep, cultivated in Asia, Barbary, and Corsica, and the Cretan sheep, which inhabits the Grecian islands, Hungary, and Austria; by Linnæus considered as species.

6385. *The varieties of British sheep* are so numerous that, at first sight, it appears almost impossible to reduce them into any regular classes. They may, however, be divided in two ways; first, as to the length of their wool; and, secondly, as to the presence or absence of horns; a third classification might be made after the place or districts in which such species are supposed to abound, to be in greatest perfection, or to have originated.

6386. *The long-wooled British sheep* are chiefly the \*Teeswater, the \*old and \*new Leicester, the \*Devonshire nots, Exmoor, and the Heath sheep.

6387. *The short-wooled sheep* are chiefly the Dorsetshire, \*Hereford or Ryeland, the \*South Down, the Norfolk, the \*Cheviot, the \*Shetland sheep, and the \*Merinos.

6388. *The hornless breeds* are those in the above classes marked (\*), the others have horns. These breeds, and their subvarieties, may be further arranged according as they are suited to arable or enclosed lands, and to open or mountainous districts.

6389. *The sheep best suited to arable land*, an eminent writer observes, in addition to such properties as are common in some degree to all the different breeds, must evidently be distinguished for their quietness and docility; habits which, though gradually acquired and established by means of careful treatment, are more obvious, and may be more certainly depended on in some breeds than in others. These properties are not only valuable for the sake of the fences by which the sheep are confined, but as a proof of the aptitude of the animals to acquire flesh in proportion to the food they consume.

6390. *The long-wooled large breeds, are those usually preferred on good grass-lands*; they differ much in form and size, and in their fatting quality, as well as in the weight of their fleeces. In some instances, with the Lincolns or old Leicesters in particular, wool seems to be an object paramount even to the carcase; with the breeders of the Leicesters, on the other hand, the carcase has always engaged the greatest attention: but neither form nor fleece, separately, is a legitimate ground of preference; the most valuable sheep being that which returns, for the food it consumes, the greatest marketable value of produce.

6391. *The Lincolnshire, or old Leicestershire breed*, have no horns, the face is white and the carcase long and thin; the ewes weighing from 14 to 20lbs., and the three-year-old wethers, from 20 to 30lbs. per quarter. They have thick, rough, white legs, bones large, pelts thick, and wool long, from ten to eighteen inches, weighing from eight to 14lbs. per fleece, and covering a slow-feeding, coarse-grained carcase of mutton. This kind of sheep cannot be made fat at an early age except upon the richest land, such as Romney-marsh, and the richest marshes of Lincolnshire; yet the prodigious weight of wool which is shorn from them every year, is an inducement to the occupiers of marshlands to give great prices to the breeders for their hogs or yearlings; and though the buyers must keep them two years more, before they get them fit for market, they have three clips of wool in the meantime, which of itself pays them well in those rich marshes. Not only the midland counties, but also Yorkshire, Durham, and Northumberland, can send their long-wooled sheep to market at two years old, fatter in general than Lincolnshire can at three. Yet this breed, and its subvarieties, are spread through many of the English counties.

6392. *The Teeswater sheep (fig. 666.)* differ from the Lincolnshire in their wool not being so long and heavy; in standing upon higher, though finer boned legs, supporting a thicker, firmer, heavier carcase, much wider upon their backs and sides; and in affording a fatter and finer-grained carcase of mutton: the two year old wethers weighing from 25 to 35lbs. per quarter. Some particular ones, at four years old, have been fed to 55lbs. and upwards. There is little doubt that the Teeswater sheep were originally bred from the same stock as the Lincolnshire; but, by attending to size rather than to wool, and constantly pursuing that object, they have become a different variety of the same original breed. (*Culley on Live Stock*, p. 122.) The present fashionable breed is considerably smaller than the original species; but they are still considerably larger and fuller of bone than the midland breed. They bear an analogy to the short-horned breed of cattle, as those of the midland counties do to the long-horned. They are not so compact, nor so complete in their form, as the Leicestershire sheep; nevertheless, the excellence of their flesh and fatting quality is not doubted, and their wool still remains of a superior staple. For the banks of the Tees, or any other rich fat-land county, they may be singularly excellent.

6393. *The Dishley, or new Leicester breed (fig. 667.)*, is distinguished from other long-wooled breeds by their clean heads, straight, broad, flat backs, round barrel like bodies, very fine small bones, thin pelts, and inclination to make fat at an early age. This last property is most probably owing to the before-specified qualities, and which, from long experience and observation, there is reason to believe, extends through every species of domestic animals. The Dishley breed is not only peculiar for its mutton being fat, but also for the fineness of the grain, and superior flavor, above all other large long-wooled sheep, so as to fetch nearly as good a price, in many markets, as the mutton of the small Highland and short-wooled breeds. The weight of ewes, three or four years old, is from 18 to 26lbs. a quarter,

666



667



and of wethers, two years old, from 20 to 30lb. The wool, on an average, is from 6 to 8lbs. a fleece. (*Culley*, p. 106.)

6394. *The Devonshire Nots* (fig. 668.) have white faces and legs, thick necks, narrow backs, and back bone high; the sides good, legs short, and the bones large; weight much the same as the Leicesters, wool heavier, but coarser. In the same county, there is a small breed of long-wooled sheep, known by the name of the *Exmoor* sheep, from the place where they are chiefly bred. They are horned, with white faces and legs, and peculiarly delicate in bone, neck, and head; but the form of the carcass is not good, being narrow and flat-sided. The weight of the quarters, and of the fleece, about two-thirds that of the former variety.



6395. *The shorter woolled varieties, and such as, from their size and form, seem well suited to hilly and inferior pastures,* are also numerous. Generally speaking, they are too restless for inclosed arable land, on the one hand, and not sufficiently hardy for healthy mountainous districts, on the other. To this class belong the breeds of Dorset, Hereford, Sussex, Norfolk, and Cheviot.

6396. *The Dorsetshire sheep* (fig. 669.) are mostly horned, white faced, stand upon high small white legs, and are long and thin in the carcass. The wethers, three years and a half old, weigh from 16 to 20lbs. a quarter. The wool is fine and short, from 3 to 4lbs. a fleece. The mutton is fine grained and well-flavored. This breed has the peculiar property of producing lambs at almost any period of the year, even so early as September and October. They are particularly valued for supplying London and other markets with house lamb, which is brought to market by Christmas, or sooner if wanted, and after that, a constant and regular supply is kept up all the winter.



6397. *The Wiltshire sheep* are a variety of this breed, which, by attention to size, have got considerably more weight; viz. from 20 to 28 lbs. a quarter. These, in general, have no wool upon their bellies, which gives them a very uncouth appearance. The variations of this breed are spread through many of the southern counties, as well as many in the west, viz. Gloucestershire, Worcestershire, Herefordshire, &c.; though some of them are very different from the Dorsetshire, yet they are, *Culley* apprehends, only variations of this breed, by crossing with different tups; and which variations continue northward until they are lost amongst those of the Lincolnshire breeds. (*Culley*, p. 131.)



6398. *The Herefordshire breed* (fig. 670.) is known by the want of horns, and their having white legs and faces, the wool growing close to their eyes. The carcass is tolerably well formed, weighing from 10 to 18lbs. a quarter, and bearing very fine short wool, from  $1\frac{1}{2}$  to  $2\frac{1}{2}$  lbs. a fleece: the mutton is excellent. The store or keeping sheep of this breed are put into racks at night, winter and summer, and in winter foddered in racks with peas-straw, barley-straw, &c., and in very bad weather with hay. These cots are low buildings, quite covered over, and made to contain from one to five hundred sheep, according to the size of the farm or flock kept. The true Herefordshire breed are frequently called *Ryeland* sheep, from the land formerly being thought capable of producing no better grain than rye; but which now yields every kind of grain. A cross between this breed and the merinos, was extensively cultivated by the late Dr. Parry, of Bath, an eminent wool-grower, and promoter of agricultural improvement.

6399. *The South Down sheep* (fig. 671.) are without horns; they have dark or black-grey faces and legs, fine bones, long small necks; are low before, high on the shoulder, and light in the fore quarter; the sides are good, and the loin tolerably broad, back-bone too high, the thigh full, and twist good. The fleece is very short and fine, weighing from  $2\frac{1}{2}$  to 3 lbs. The average weight of two years old wethers is about 18 lbs. per quarter, the mutton fine in the grain, and of an excellent flavor. These sheep have been brought to a high state of improvement by Elman, of Glynd, and other intelligent breeders. They prevail in Sussex, on very dry chalky downs, producing short fine herbage.



6400. In the *Norfolk sheep* the face is black, horns large and spiral; the carcass is very small, long, thin, and weak, with narrow chins, weighing from 16 to 20 lbs. per quarter; and they have very long dark or grey legs, and large bones. The wool is short

and fine, from  $1\frac{3}{4}$  to 2 lbs. per fleece. This race have a voracious appetite, and a restless and unquiet disposition, which makes it difficult to keep them in any other than the largest sheep-walks or commons. They prevail most in Norfolk and Suffolk, and seem to have been retained solely for the purpose of folding; as it does not appear they have any other good property to recommend them, besides being good travellers, for which they seem well adapted, from their very long legs and light clean carcasses.

6401. *The Cheviot breed* (fig. 672.) are without horns, the head bare and clean, with jaws of a good length, faces and legs white. The body is long, but the fore-quarters generally want depth in the breast, and breadth both there and on the chine; though, in these respects, great improvement has been made of late. They have fine, clean, small-boned legs, well covered with wool to the hough.

The weight of the carcase, when fat, is from 12 to 18 lbs. per quarter; their fleece, which is of a medium length and fineness, weighs about 3 lbs. on an average. Though these are the general characters of the pure Cheviot breed, many have grey or dun spots on their faces and legs, especially on the borders of their native districts, where they have intermixed with their black-faced neighbors. On the lower hills, at the extremity of the Cheviot range, they have been frequently crossed with the Leicesters, of which several flocks, originally Cheviot, have now a good deal both of the form and fleece. The best kind of these sheep are certainly a very good mountain stock, where the pasture is mostly green sward, or contains a large portion of that kind of herbage, which is the case of all the hills around Cheviot, where those sheep are bred. Large flocks of them have been sent to the Highlands of Scotland, where they have succeeded so well as to encourage the establishment of new colonies; yet they are by no means so hardy as the heath or black-faced kind, which they have, in many instances, supplanted.

6402. *Of those races of sheep that range over the mountainous districts of Britain*, the most numerous, and the one probably best adapted to such situations, is the *heath breed*, distinguished by their large spiral horns, black faces and legs, fierce wild-looking eyes, and short, firm carcasses, covered with long, open, coarse shagged wool. Their weight is from 10 to 16 lbs. a quarter, and they carry from 3 to 4 lbs. of wool each. They are seldom fed until they are three, four, or five years old, when they fatten well, and give excellent mutton, and highly flavored gravy. Different varieties of these sheep are to be found in all the western counties of England and Scotland, from Yorkshire northwards, and they want nothing but a fine fleece to render them the most valuable upland sheep in Britain.

6403. *The Herdwick sheep* (fig. 673.) are peculiar to that rocky mountainous district, at the head of the Duddon and Esk rivers in the county of Cumberland. They are without horns, have speckled faces and legs, wool short, weighing from 2 to  $2\frac{1}{2}$  lbs. per sheep, which, though coarser than that of any of the other short-wooled breeds, is yet much finer than the wool of the heath sheep. The mountains upon which the Herdwicks are bred, and also the stock itself, have, time immemorial, been farmed out to herds, and from this circumstance their name is derived.

6404. *The dun-faced breed*, said to have been imported into Scotland from Denmark or Norway at a very early period, still exists in most of the counties to the north of the Firth of Forth, though only in very small flocks. Of this ancient race there are now several varieties, produced by peculiarities of situation, and different modes of management, and by occasional intermixture with other breeds.

We may, therefore, distinguish the sheep of the mainland of Scotland from those of the Hebrides, and of the northern islands of Orkney and Zetland.

6405. *The Hebridean sheep* is the smallest animal of its kind. It is of a thin, lank shape, and has usually straight shorn horns. The face and legs are white, the tail very short, and the wool of various colors; sometimes of a bluish grey, brown or deep russet, and sometimes all these colors meet in the fleece of one animal. Where the pasture and management are favorable, the wool is very fine, resembling in softness that of Shetland; but, in other parts of the same islands, the wool is stunted and coarse, the animal sickly and puny, and frequently carries four, or even six horns. The average weight of this poor breed, even when fat, is only 5 or  $5\frac{1}{2}$  lbs. per quarter, or nearly about 20 lbs. per sheep. It is often much less, only amounting to 15 or 16 lbs.; and the price of the animal's carcase, skin and all, is from 10s. to 14s. Fat wethers have been sold in the Long Island at 7s. a head, and ewes at 5s. or 6s. The quantity of wool which the fleece yields is equally contemptible with the weight of the carcase. It rarely exceeds one pound weight, and is often short of even half that quantity. The quantity of the wool is different on different parts of the body; and inattention to separating the fine from the coarse, renders the cloth made in the Hebrides very unequal and precarious in its texture. The average value of a fleece of this aboriginal Hebridean breed is from 8d. to 1s. sterling. From this account it is plain, that the breed in question has every chance of being speedily extirpated. (*Macdonald's Report of the Hebrides*, p. 447.)

6406. *Of the Zetland sheep* it would appear that there are two varieties, one of which is considered to be the native race, and carries very fine wool; but the number of these is much diminished, and in some places they have been entirely supplanted by foreign breeds; the other variety carries coarse wool above, and soft fine wool below. They have three different successions of wool yearly, two of which resemble long hair more than wool, and are termed by the common people *fors* and *scudda*. When the wool begins to loosen in the roots, which generally happens about the month of February, the hairs, or *scudda*, spring up; and when the wool is carefully plucked off, the tough hairs continue fast until the new wool grows up about a quarter of an inch in length, then they gradually wear off; and when the new fleece has acquired about two months' growth, the rough hairs, termed *fors*, spring up and keep root until the proper season

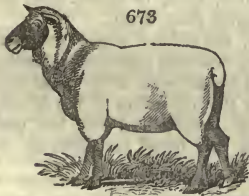

for pulling it arrives, when it is plucked off along with the wool, and separated from it, at dressing the fleece, by an operation called forsing. The scudda remains upon the skin of the animal as if it were a thick coat, a fence against the inclemency of the seasons, which provident nature has furnished for supplying the want of the fleece. The wool is of various colors; the silver grey is thought to be the finest, but the black, the white, the *mourat*, or brown, is very little inferior, though the pure white is certainly the most valuable for all the finer purposes in which combing wool can be used. (*Sir John Sinclair on the different Breeds of Sheep, &c. Appendix, No. 4. Account of the Shetland Sheep, by Thomas Johnston, p. 79.*) In the northern part of Kincardineshire, as well as in most other of the northern counties, there is still a remnant of this ancient race, distinguished by the yellow color of the face and legs, and by the dishevelled texture of the fleece, which consists in part of coarse, and in part of remarkably fine wool. Their average weight in that county, is from seven to nine pounds a quarter, and the mutton is remarkably delicate and highly flavored. (*Kincardineshire Report, p. 385. Sup. E. Brit. art. Agr. 176.*)

6407. *The Spanish, or Merino breed, bears the finest wool of the sheep species; the*

674

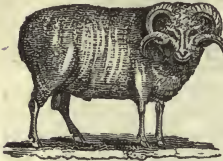

males (*fig. 674.*) usually have horns of a middle size, but the females (*fig. 675.*) are frequently without horns: the faces and legs are white, the legs rather long, but the bones fine. The average weight per quarter of a tolerably fat ram, is about seventeen pounds, and that of ewes about eleven pounds. The shape of

675



this race is far from being perfect, according to the ideas of English breeders, with whom symmetry of proportion constitutes a principal criterion of excellence. The throatiness, or pendulous skin beneath the throat, which is usually accompanied with a sinking or hollow in the neck, presents a most offensive appearance, though it is much esteemed in Spain, as denoting both a tendency to fine wool, and a heavy fleece. Yet the Spanish sheep are level on the back, and behind the shoulders; and Lord Somerville has proved that there is no reason to conclude that deformity in shape is, in any degree, necessary to the production of fine wool.

6408. *The fleece of the Merino sheep weighs, upon an average, from three to five pounds; in color, it is unlike that of any English breed: there is on the surface of the best Spanish fleeces, a dark brown tinge, approaching almost to a black, which is formed by dust adhering to the greasy properties of its pile, and the contrast between this tinge and the rich white color below, as well as that rosy hue of the skin which denotes high proof, at first sight excites much surprise. The harder the fleece is, the more it resists any external pressure of the hand, the more close and fine will be the wool: here and there, indeed, a fine pile may be found in an open fleece, though this occurs but rarely. Nothing, however, has tended to render the Merino sheep more unsightly to the English eye, than the large tuft of wool which covers the head; it is of a very inferior quality, and classes with what is produced on the hind legs; on which account, it does not sort with any of the three qualities, viz. *rafinos*, or prime, *finos*, or second best, and *tercenos*, the inferior sort, and consequently, is never exported from Spain.*

6409. *Merinos were first brought into England in 1788, but did not excite much interest before his Majesty's sales, which began in 1804: the desirable object of spreading them widely over the country, and subjecting them to the experiments of the most eminent professional breeders, has been greatly promoted by the institution of the Merino Society in 1811, to which belonged some of the greatest landholders, and the most eminent breeders in the kingdom. For some years past, this breed has been on the decline. (Sup. E. Brit. art. Agr.)*

## SECT. II. *Criteria of Properties in Sheep.*

6410. *The criteria of an excellent ram, as given by Culley, combines qualities which ought to be found in every breed of sheep cultivated for its flesh and wool. His head should be fine and small, his nostrils wide and expanded, his eyes prominent, and rather bold or daring, ears thin, his collar full from his breast and shoulders, but tapering gradually all the way to where the neck and head join, which should be very fine and graceful, being perfectly free from any coarse leather hanging down; the shoulders broad and full, which must, at the same time, join so easy to the collar forward, and chine backward as to leave not the least hollow in either place; the mutton upon his arm or fore-thigh, must come quite to the knee; his legs upright, with a clean fine bone, being equally clear from superfluous skin and coarse hairy wool, from the knee and hough downwards; the breast broad and well forward, which will keep his fore-legs at a proper wideness; his girth or chest full and deep, and instead of a hollow behind the shoulders, that part, by some called the fore-flank, should be quite full; the back and loins broad, flat, and straight, from which the ribs must rise with a fine circular arch; his belly straight, the quarters long and full, with the mutton quite down to the hough, which should neither stand in nor out; his twist, or junction of the inside of the thighs, deep, wide, and full, which, with the broad breast, will keep his four legs open and upright; the whole body covered with a thin pelt, and that with fine, bright, soft wool.*



6411. *The criteria of a sound healthy sheep*, are, a rather wild or lively briskness; a brilliant clearness in the eye; a florid ruddy color on the inside of the eyelids, and what are termed the eyestrings, as well as in the gums; a fastness in the teeth; a sweet fragrance in the breath; a dryness of the nose and eyes; breathing easy and regular; a coolness in the feet; dung properly formed; coat or fleece firmly attached to the skin, and unbroken; the skin exhibiting a florid red appearance, especially upon the brisket. Where there are discharges from the nose and eyes, it indicates their having taken cold, and should be attended to by putting them in dry sheltered situations. This is a necessary precaution also in bringing them from one situation to another while on the road.

6412. *The criteria of the age of sheep* is the state of their teeth: by their having, in their second year, two broad teeth; in their third year, four broad teeth; in their fourth year, six broad teeth; and in their fifth year, eight broad teeth before. After which, none can tell how old a sheep is while their teeth remain, except by their being worn down. About the end of one year, rams, wethers, and all young sheep, lose the two fore-teeth of the lower jaw; and they are known to want the incisive teeth in the upper jaw. At eighteen months, the two teeth joining to the former, also fall out; and at three years, being all replaced, they are even and pretty white. But as these animals advance in age, the teeth become loose, blunt, and afterwards black. The age of the ram, and all horned sheep, may also be known by their horns, which show themselves in their very first year, and often at the birth, and continue to grow a ring annually to the last period of their lives.

6413. *The different ages and conditions of sheep* have different names in different districts. After being weaned, the ram, or wedder lamb, is sometimes termed hog, hoggit, or tag, during the whole of the first year; and the female lamb, an ewe, or gimmer lamb, and ewe tag. The second year the wedder has the title of shear hog, or a two-toothed tag; and the ewe is called a thaive, or two-toothed ewe. In the third year, a shear hog, or four-toothed wedder; and a four-toothed ewe or thaive. The fourth year, a six-toothed wedder, or ewe; and in some places, from the time of lambing till that of salving, the males are called tup-lambs; and from that period, till the time of shearing, tup-hogs, and ever afterwards, tups: the females in the same order being termed, ewe-lambs, ewe-hogs, gimmers, young ewes, old ewes. The gelded male lambs, castrated wedder lambs, wedder hogs, dummonds, wedders. Crones also signify old ewes; and there are several other provincial names, which are explained in their proper places.

### SECT. III. *Of Breeding Sheep.*

6414. *In the breeding of sheep* a greater degree of perfection has been attained than in any other live stock; and in this branch, in particular, the breeders of England stand higher than those of any other country. Bakewell, by careful selection during several generations, raised his stock to a state of excellence, in regard to fattening at an early age with a moderate consumption of food, and with the smallest proportion of offal, which has been with difficulty equalled, certainly has not been exceeded, by the most skilful of his successors. It is a striking instance of the division of labor and skill, that there are breeders who devote themselves entirely to the breeding of rams for the purpose of letting out on hire. This practice originated in Lincolnshire, where in the early part of the last century, rams were let out at from 10s. to 20s. each; but so great has been the improvement since that period that they are now let out to common graziers at from 1 to 10 guineas, and to breeders of rams at from 20l. to 200 guineas. The breeding rams are shown for hire at certain times and places during the summer, where every one may select such as promise to maintain or improve the particular state of his flock, and at such prices as his means and experience may justify. Two or more individuals frequently join together in the hire of one ram, to which they put the best of their ewes, for the purpose of obtaining superior males for the future service of the rest of their flocks; and in particular cases, when the owner of the ram does not choose to part with him, even for a season, ewes are sent to him to be covered at a certain price per head; superior animals of this class being very seldom sold altogether. Much as this mode of doing business has been reprobated as a monopoly, and much as there sometimes may be of deception in *making up* rams for these shows, all intelligent practical men must agree, that there can be no better method of remunerating eminent breeders, and of spreading their improvements most widely, in the shortest period, and at the least possible expense. A single ram thus communicates its valuable properties to a number of flocks, often in distant parts of the country, without distracting the attention of ordinary breeders from their other pursuits.

6415. *The two methods of breeding common to all animals* are also adopted in breeding sheep. Breeding from different families of the same race, commonly called *breeding in and in*; and breeding from different races, generally called *cross breeding*. Bakewell, according to Sir J. Sebright, (*On improving the Breeds of domestic Animals, &c.*), effected his improvements by breeding from the same family; but according to Hunt, who

has written an able answer to Sir J. Sebright's pamphlet, (*Letter, &c. to Sir J. Sebright, &c.*), he bred from different relationships of the same family; it being out of his power to breed from different families of a race which he was at the time employed in forming, and cross breeding he did not approve of. Breeding *in and in* is so repugnant to human feeling, that it is difficult to avoid considering it an unnatural practice; for it does not follow that a flock of sheep in a wild state must necessarily breed in the nearest relationships, as father and daughter, &c.; on the contrary, it is more probable that remoter relationships would be chiefly bred from, as these must necessarily be much more numerous. In a flock of sheep, or a herd of savage men, springing each from one pair, every parent must necessarily have many more cousins, and cousins many times removed, than he can have mothers or daughters.

6416. *Breeding from different families of the same race* is the more general and approved practice. When a number of families of any breed have been for some time established in a variety of situations, and have had some slight shades of difference impressed upon them, by the influence of different soils and treatment, it is found advantageous to interchange the males, for the purpose of strengthening the excellencies, or remedying the defects of each family. Of this advantage, Bakewell could not avail himself; but it has been very generally attended to by his successors. Culley, for many years, continued to hire his rams from Bakewell, at the very time that other breeders were paying a liberal price for the use of his own; and the very same practice is followed by the most skilful breeders at present. In large concerns, two or more streams of blood may be kept distinct for several generations, and occasionally intermixed with the happiest effects, by a judicious breeder, without having recourse to other flocks. (*Sup. E. Brit. art. Agr. 177.*)

6417. In *breeding from two distinct races*, the object is to acquire new properties or remove defects. The mode of effecting this by cross breeding is attended with greater difficulties than in breeding from the same race. The very distinction of breeds implies a considerable difference among animals in several respects; and although the desirable property be obtained, it may be accompanied by such others as are by no means advantageous to a race, destined to occupy a situation which had excluded that property from one of its parents. To cross any mountain breed with Leicester rams, for example, with a view to obtain a propensity to fatten at an early age, would be attended with an enlargement of size, which the mountain pasture could not support; and the progeny would be a mongrel race, not suited to the pastures of either of the present breeds. If the object be to obtain an enlargement of size, as well as a propensity to fatten, as is the case when Cheviot ewes are crossed with Leicester rams, the progeny will not prosper on the hilly pastures of their dams, and will be equally unprofitable on the better pastures of their sires. But the offspring of this cross succeeds well on those intermediate situations on the skirts of the Cheviot hills, where, though the summer pasture is not rich, there is a portion of lowland for producing clover and turnips. (*Supp. Encyc. Brit. art. Agr. &c.*)

6418. As *general rules in crossing breeds* it is to be noticed that in every case where the enlargement of the carcass is the object, the cross breed must be better fed than its smaller parent. The size of the parents should also be but little disproportioned at first; and when some increase has been produced, one or more crosses afterwards may raise the breed to the required size. With these precautions, there is little reason to fear disappointment, provided both parents are well formed. (*General Report of Scotland, vol. iii. p. 14. 18.*)

6419. *The most advantageous and proper age for ewes taking the ram* in the different breeds has not been fully shown; but from a year to a year and a half old may be sufficient, according to the forwardness of the breed and the goodness of the keep. Some judge of this by the production of broad or sheep's teeth. It should not be done while too young in any case.

6420. In regard to *the season of putting the rams to the ewes*, it must be directed by the period at which the fall of the lambs may be most desirable, which must depend on the nature of the keep which the particular situation affords; but the most usual time is about the beginning of October; except in the Dorsetshire ewes, where the intention is suckling for house-lamb, in which case it should be much earlier, in order that the lambs may be sufficiently forward. But, by being kept very well, any of the breeds will take the ram at a much earlier period. Where the rams are young, the number of ewes should seldom exceed sixty for each ram; but in older rams a greater number may be admitted without inconvenience, as from one to two hundred; but letting them have too many should be cautiously avoided, as by such means the farmer may sustain great loss in the number of the lambs.

6421. With respect to *the period of gestation*, the ewe goes with lamb about the space of five months, consequently the most common lambing-season is March, or the early part of April; but "it has been observed that in many of the more southern districts, where sheep-husbandry is carried on to a considerable extent, some parts of the ewe-stocks are put to the rams at much earlier periods, so as to lamb a month or six weeks sooner; a

practice which is attended with much profit and advantage in many situations where early grass-lamb is in great demand. It is usual for the rams to remain with the ewes for a month or six weeks, and in some cases longer, in order to complete the business of impregnation, which in some districts is ascertained by smearing the fore-bows of the rams with some coloring substance."

6422. *The practice of turning a number of rams among the flocks, formerly adopted, is highly exceptionable, as tending to prevent the main object, and injure the rams. A better way is to let each ram have a proper number of ewes, and with very choice stock to keep the ram in an inclosed small pasture, turning a few ewes to him, and as they are served replacing them with others. By this means there is more certainty, and more ewes may be impregnated. In such sort of fine stock, it is likewise of great utility to keep the rams during this season in a high manner. In this view a little oats in the straw, or a mixture of barley and pea meal, are excellent. Where ewes are backwards in taking the ram, the best means to be employed are those of good stimulating keep. The rams should always be continued with the ewes a sufficient length of time.*

6423. *The ewe will breed twice or even thrice a year, if it be made a point to produce such an effect by attention and high keep, since she will receive the male indifferently at any season, and, like the rabbit, very soon after bringing forth. Lisle gives an instance of three of his ewes, well kept, lambing at Christmas, fattening off their lambs at Lady-day, and producing lambs again the first week in June. It seems they stole the ram immediately after lambing, but brought the second time only single lambs, although of a breed that generally produces twins. There is no doubt but the sheep would produce young thrice a year, were the bad practice resorted to, which has been so currently recommended with the rabbit, of allowing the male immediately after parturition; the ready way to render both the female and her progeny worthless. Could the lambs be advantageously weaned at two months, sufficient time would, he conceives, remain for the ewe to bring forth twice within the year: for example, suppose the young ewe tupped in August, the lamb would be dropped in the middle of January, and might be weaned in mid March, the ewe again receiving the ram on the turn of the milk, like the sow, perhaps in or before April, she would then bring forth within the twelve months or in August. This plan would, continues Lisle, at least injure the dam infinitely less than suckling during gestation.*

6424. *When ewes are in lamb they should be kept in the pastures, and as free from disturbance as possible, being carefully attended to, in order to prevent accidents which are liable to take place at this time, such as those of their being cast in the furrows, &c. Where any of the ewes slip their lambs, it is advised by Bannister that they should be immediately removed from the flock. They also require, under these circumstances, to be kept as well as the nature of the farm will admit, in order that there may be less loss at lambing-time from the ewes being stronger, and the lambs more healthy, and better capable of contending with the state of the season at which they may be dropped. The shepherd should at this period be particularly careful and attentive to afford his assistance where it may be necessary. He should constantly have regard to the suckling of the lambs, and to see that the udders of the ewes are not diseased. His attendance will often be required in the night as well as the day. At this season covered sheep folds are often of very great advantage, in saving and protecting both ewes and their lambs.*

6425. *In respect to the number of lambs at a birth, it is remarked by Lawrence that the ewe brings most commonly one, next in degree of frequency, two, rarely from three to five lambs at a birth. This property of double birth, is, he says, in some instances specific; the Dorset sheep usually yeaning twins, and the large polled Belgic sheep, with their descendants, our Teeswater, doing the same, and producing occasionally more at a birth. Other breeds bring twins, in the proportion of one third of the flock, which is supposed to depend considerably on good keep. A certain number of ewes per centum prove barren annually: the cause very rarely, natural defect; sometimes over-fatness, a morbid state of body from poverty or neglect of the ram, in other words want of system in the shepherd.*

6426. *The keep of sheep after lambing, where rich pastures or other kinds of grass lands cannot be reserved, should consist of turnips or other kinds of green food provided for the purpose, and given them in a suitable manner; but where it can be done, it is always better to leave this sort of food untouched till about the period of lambing, when it should be regularly supplied in proportion to the necessity there may be for it. The ewes also demand at this time much care to see that they are put upon a dry sheltered pasture, free from disturbance, and that neither they or their lambs sustain injury from the too great severity of the season. Whenever this is the case, they should be carefully removed into a proper degree of warmth and shelter until perfectly restored. It is likewise a necessary as well as useful practice, as they lamb down, to take them and their lambs away from the common stock, putting them into a piece of turnips or fresh dry pasture where there is shelter when necessary, as by this means much fewer lambs would be lost than would otherwise be the case. It is also found that by a proper supply of turnips or other similar green food at this period, the milk of the ewes is much increased, and the growth of the lambs greatly promoted; which is of much future importance, as when they are stinted at this early period of their existence, they never turn out so well afterwards for the farmer. With the green and root crops and preserved after-grass, hay, straw, corn, and oil cake, are in some cases made use of in the winter support of sheep stock. With turnips, where the soil is not sufficiently dry to admit the sheep, it is the practice to draw them and convey them to a sound firm pasture, that the ewes may be baited upon them once or twice in the day, as there may be occasion, care being taken that they are eaten up clean, as the circumstance of their being thus eaten may serve as a guide to the farmer for the supply that may be daily necessary. In this way this sort of food will be consumed with the greatest economy. Where the land is perfectly dry, and the intention is to manure it for a grain crop, eating the turnips on the land, by means of portions hurdled off as wanted, is a good practice. With this sort of*

food, especially where it produces scouring in the ewes, green rouen hay, cut straw, or pease haulm should constantly be given, and also with rape, &c.

6427. *The castrating lambs* may be performed any time from the age of a fortnight or three weeks, to that of a month or six weeks, and in some districts it is deferred to a considerably later period. It is, however, the safest method to have it executed early, as there is less danger of too much inflammation taking place. But in all cases the lambs should be in a healthy state when it is done, as under any other circumstances they are liable to be destroyed by it. The operation is usually performed by the shepherd, by opening the scrotum or cod, and drawing out the testicles with the spermatic cord. This he often does with his teeth in the young state of the animal. But where the operation is performed at a later period, it is usual to have recourse to the knife, the arteries being taken up and secured by means of ligatures, or the searing iron. The business, if possible, should be done in fine weather, when not too warm, and the gelded lambs be kept in a dry, sheltered, quiet situation for a few days, until the inflammation is gone off. If it should happen to be wet at the time, it may be advisable to have them under some sort of shelter, where they can have room to move freely about.

6428. *The weaning of lambs* should be effected when they are three or four months old, as about July, but it is done more early in some districts than in others. A proper reserve of some fresh pasture grass, where there may be a good bite for the lambs to feed upon, should be had recourse to, as it is of much consequence that an ample provision of this sort be had, in order that the growth of this young stock may not suffer any check on being taken from the mother. Where they have been continued so long as to graze with the dams, little check will be sustained in their separation if turned upon such good feed. Some advise clover in blossom as the most forcing sort of food in this intention, and with others saintfoin rouen is highly valued for the same purpose. When good feed is not provided, of some of these kinds, the lambs soon decline in flesh, or, in the technical language of the flock, are said to pitch; and when once this happens, they never afterwards thrive so well, however good the management may be. With regard to the ewes, they should be removed to such distant pastures, or other places as that they may not be heard by the lambs, which would cause them to be disturbed in their feeding. And where the ewes sustain any inconvenience from their milk, as by their udders swelling, it should be drawn once or twice, as by this means bad consequences may be prevented. And as soon as the lambs have been removed, the ewes are returned upon the pastures destined for their summer support. There is, however, one caution to be attended to in first turning the lambs upon rich keep, which is that of letting them be in some degree satisfied with food previously, that they may not be surfeited by too quick and full feeding, and *heave* or *hove* as it is termed; keeping them gently moving about the field has also been advised in this intention. In some places where the lands are of the more poor kind, it is a custom to send the lambs to the more rich vale or marsh districts, to be brought forward in condition or fattened. In those cases, where the lambs of the male kind are reared on the home lands, as wethers, they are usually restored to the flock in the latter end of the year, but which is not by any means a good practice, as they often suffer for want of proper keep in the winter, and lose what they had previously gained in growth and condition.

#### SECT. IV. *Of the Rearing and general Management of Sheep.*

6429. *In the practice of sheep husbandry different systems are had recourse to*, according to the extent and nature of the farms on which they are kept, and the methods of farming that are adopted on them; but under all circumstances the best sheep-masters constantly endeavor to preserve them in as good condition as possible at all seasons. With the pasture kinds of sheep this is particularly the case; and with the view of accomplishing it in the most complete manner, it is useful to divide them into different parcels or lots in respect to their ages and sorts, as by that practice they may be kept with greater convenience and benefit than in large flocks together under a mixture of different kinds; as in this way there is not only less waste of food, but the animals thrive better, and the pastures are fed with much more ease. The advantage of this management has been fully experienced in many of the northern districts, where they usually divide the sheep-stock into lambs, yearlings, wethers, and breeding ewes: and in this method it appears not improbable that a much larger proportion of stock may be kept, and the sheep be preserved in a more healthy condition. With a breeding stock the sheep-master must act according to his circumstances, situation, and capital which he possesses, either selling the lambs to go to keep, fattening them for grass lamb, suckling them for house lamb, or keeping them on to be grazed and sold as store or fat wethers; the ewes being sold lean as they are called, or fattened as circumstances, profit, and convenience may point out.

6430. *Another practice*, but which requires much capital as well as knowledge, experience, and attention, is that of breeding and fattening off all lambs, both wethers and ewes, especially where markets for their sale when fat, are conveniently situated; or this system may be partially acted upon, varying the plan according to capital, circumstances, and the nature of the times. In which case, whenever store stock become extravagantly high, it is mostly a good way to sell.

6431. *The sheep farming of the arable or low warm districts of the kingdom consequently differs in various particulars from that of the hilly and mountainous districts*; we shall therefore first give a general view of the sheep management of arable lands, and next of mountainous districts.

SUBJECT. 1. *Of the Rearing and Management of Sheep on rich grass and arable Lands.*

6432. *The most general sheep husbandry on rich lands, or where turnips and other green food is raised for winter consumption, is to combine the breeding and feeding branches, leaning to each according to the returns of profit*: a method very common among arable farmers, and which is attended with the least trouble and hazard, is that of purchasing a store flock, as lambs, wethers, and what are termed crones, or old ewes; some of the last sort often proving with lamb, may be fattened off with them to good account. It is likewise often the case that ewes are disposed of in lamb, or with lambs by their sides, in what are termed couples, in which circumstances, it is frequently a good practice to make annual purchases of them, in order to the fattening of both, and selling them in that state within the year. In the purchasing of sheep, which is often done from very distant fairs and markets, much care and circumspection is necessary, whatever the sort or intention with which they are bought may be. In these cases much advantage, especially when at a considerable distance, may be derived by employing a salesman on the spot.

6433. *The treatment of the lambs is the first consideration in the mixed sheep husbandry*: lambs are either suckled or fattened on grass, or sold in autumn as lean stock. Those that have been suckled or fattened in the house, in which system of fattening, much attention is required to have them early, to their being well, regularly, and very cleanly kept and suckled, as well as to the ewes being of the right sort, and the best milkers that can be provided, and to their being fully supplied with food of the most nourishing and succulent kinds. Their tails and udders should have the wool well clipped away from them, in order that they may be preserved in a perfectly clean state. The lambs also require, especially towards the close of their fattening, to have regular supplies of barley, wheat, and pease meal, ground together in combination with fine green rouen hay. When these have been sold off, the lambs which have been fattened on the best grass land will be ready to succeed them at the markets, in the spring and summer months, and these will be followed by the sale of the store lambs, at the different autumnal fairs.

6434. *The selection or setting of the lamb-stock is the first business of sheep management after the lambs have been weaned. It is generally performed in the month of August, at which period the fairs for the sale of lambs mostly take place. And as at this time the whole are collected together for drawing into different lots, it is a very suitable period for selecting or choosing those that are to supply such deficiencies in the breeding flocks. In his Calendar of Husbandry, Young has remarked, that in making this selection the farmer or his shepherd usually (whatever the breed may be) rejects all that manifest any departure from certain signs of the true breed: thus, in a Norfolk flock, a white leg, and a face not of a hue sufficiently dark, would be excluded, however well formed; in the same manner a white face on the South Downs; in Wiltshire a black face would be an exclusion, or a horn that does not fall back; in Dorsetshire a horn that does not project, &c.*

6435. *The selection of the grown stock generally takes place after the lambs are weaned, or, at all events, before tupping season, though wethers may be drawn out of the flock at any time. A certain number of old ewes or crones are removed every year, and these as well as the wethers, are fed off for the butcher, either on grass, artificial herbage, or roots, according to the situation and circumstances of the farm, and season of the year.*

6436. *The shearing of sheep is an annual operation, which includes several preparatory measures and after-processes. These are, washing, separation, catching, clipping, marking, and tail cutting.*

6437. *The proper time for clipping or shearing sheep must be directed by the state of the weather and the climate in the particular district, as by this means the danger of injury by cold from depriving the sheep of their coats at too early a season, and from heat by permitting them to continue on them too long, may be avoided in the best manner: but another circumstance that should likewise be attended to in this business, is that of the wool being fully grown or at the state of maturity; as where the clipping precedes that period, it is said in the *Annals of Agriculture* to be weak and scarcely capable of*

being spun, and if protracted later, it is yellow, felted, and of an imperfect nature. It has been stated, that for the more warm sheltered situations in the southern parts of the kingdom, the beginning or middle of June, when the weather is fine, may be in general the most proper; but in the more exposed districts in the northern parts of the island, the middle or latter end of the same month may be more suitable, provided the season be favorable. But with the fattening sheep in the inclosures, it will mostly be necessary to perform the work at an earlier period in every situation, as the great increase of heat from the setting in of the summer weather, added to the warmth of the fleece, becomes very oppressive and injurious to them in their feeding.

6438. *Sheep-shearing, in Romney Marsh*, commences about midsummer, and finishes about the middle of July. Those who shear first, think they escape the effects of the fly, and those that shear late, apprehend they gain half a pound weight in every fleece, by the increased perspiration of the sheep. In early shearing, the wool has not the condition which it afterwards acquires, but the hot weather occasions a good deal of trouble in detecting the fly! The lambs are generally shorn, especially in the northern districts, a few weeks after the old sheep, and the operation is termed *shertling*. The lambs that are sold in Smithfield market are, we believe, seldom or ever shorn.

6439. *Clipping off the coarse soiled wool* about the thighs and docks, some weeks before the usual time of washing and clipping the sheep, is an excellent practice; as by this means the sheep are kept clean and cool when the season is hot, and with ewes the udders are prevented from becoming sore.

6440. In *separating* for the purpose of washing, the flock is brought to the side of the washing-pool, and there lambs and sheep of different kinds, fit to be washed, are put into separate fields; and such lambs as are too young to be clipped are not washed, but confined in a fold or enclosure of any kind, at such a distance from the washing place as that they may not disturb their mothers by their bleating. The object of washing is simply to free the fleece from dust and dirt of various kinds. In Devonshire and Spain, the short-wooled sheep are not washed.

6441. In *performing the operation of washing*, it was formerly the method to have the washers standing up to the breast in the water; but from the inconvenience and danger of it, the men requiring a large supply of spirituous liquors, and being liable to be attacked with colds, rheumatisms and other diseases, as well as being apt to dispatch the work with too much expedition, so as to leave the wool insufficiently clean; it has been proposed by Young, in his *Calendar*, to rail off a portion of the water in a stream or pond (*fig. 676.*), for the sheep to walk into by a sloping mouth

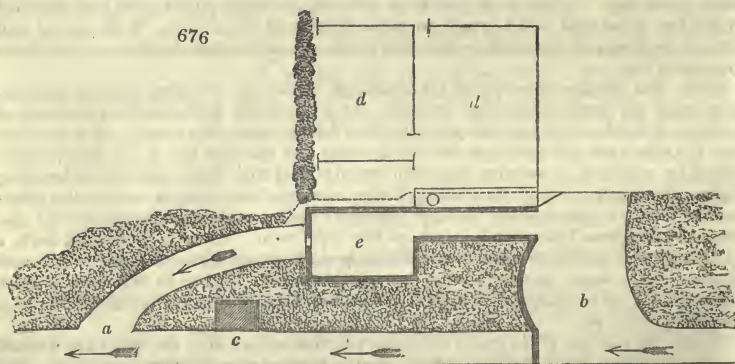

at one end (a), and to walk out by another at the other end (b), with a depth sufficient at one part for them to swim; and to pave the whole: the breadth need not be more than six or seven feet. At one spot on each side of this passage, where the depth is just sufficient for the water to flow over the sheep's back, a cask or box (c), water-tight, should be fixed, for a man to stand in dry; the sheep being in the water between them, they wash in perfection, and pushing them on, they swim through the deep part, and walk out at the other mouth, where a clean pen (d), or a very clean dry pasture is ready to receive them; of course there is a bridge rail-way to the tubs, and a pen at the first mouth of the water (e), whence the sheep are turned into it, where they may be soaking for a few minutes before being driven to the washers. But other more cheap contrivances may be provided, where there is clean water at hand for the purposes.

6442. *After sheep are washed*, they should on no account be driven on dry or dusty roads; but should have a clean hard pasture for a few days, until they are perfectly dry and in a proper condition to be shorn.

6443. The common method of *catching the sheep*, in order to lay it on its back to be shorn, is by the hinder leg, drawing the animal backward with a crook (fig. 677 a, b, c) to the adjacent shearing place; the hand holding the leg to be kept low, when at the place it is turned on its back; or they are moved bodily, or one hand placed on the neck, and another behind, and in that manner walked along: the first or common mode he thinks the most safe. Sheep fed on rich pastures, and fleshy, if handled hard and bruised, the parts are liable to fatal mortifications; an accident which often happens, on which accounts pens upon some lands are obliged to be lined with woollen, or many would die from bruises.

6444. In performing the operation of *shearing*, the left side of the sheep is placed against the shearer's left leg, his left foot at the root of the sheep's tail, and his left knee at the sheep's left shoulder. The process commences with the shears at the crown of the sheep's head, with a straight cut along to the loins, returning to the shoulder, and making a circular shear around the off side to the middle of the belly; the off hinder leg next: then the left hand holding the tail, a circular shear of the rump to the near huck of the sheep's hind leg; the two fore feet are next taken in the left hand, the sheep raised, and the shears set in at the breast, when the remaining part of the belly is sheared round to the near stifle; lastly, the operator kneeling down on his right knee, and the sheep's neck being laid over his left thigh, he shears along the remaining side.

6445. The method in *Northumberland* is to begin at the back part of the head, in order to give room for the shears to make their way down the right side of the neck, to the middle of the breast. The man then sits down upon his right knee, laying the head of the sheep over his left knee bent, and beginning at the breast, clips the underside of the throat upwards to the left check; then takes off the back of the neck, and all the way down below the left shoulder. He then changes to the contrary side, and makes his way down to the open of the right flank. This done, he returns to the breast, and takes off the belly, after which it matters not which side he clips, because being able to clip with either hand, he meets his shear points exactly at the middle of the back, all the way, until he arrive at the thighs or legs. He then places the sheep on its left side, and putting his right foot over the neck, and the other forward to the undermost hind leg, clears the right side; then turning the sheep over, finishes the whole.

6446. The fleece being removed, is wound up; that is, deprived of any clotted wool or dirty part, and lapped with the shorn side outwards, beginning at the breech and ending at the shoulders, where the neat wool serves as a bandage.

6447. *Marking* is performed on each sheep as soon as the fleece is removed. The object is to identify the individuals as the property of the master. Sometimes initials are impressed, and at other times other marks. They are impressed by stamps, or merely chalked or painted on. A stamp dipped in warm tar is the most durable mode. Some place the mark on different parts of the sheep, according to its age; others cut the margin of the ears in different ways.

6448. *Shortening the tails of the sheep* is performed in almost all the sheep districts of the kingdom except in Dorsetshire, which seems to be an useful practice in keeping the animals more clean behind, and of course less liable to be stricken with the fly. It has however been suggested in the ninth volume of *Annals of Agriculture*, that by this custom the sheep may be rendered less able to drive away the flies. The general prevalence of the practice would, however, seem to prove its being of advantage. There is much difference in the manner of performing the business in different districts in respect to the length, but four or five inches being left, is quite sufficient. It is usually done while the animals are young. In all sheep pastures the hedges should be well cleared from briars, as their coats are often injured by being torn by them. And all sorts of pernicious reptiles should be as much as possible destroyed, and removed from such land.

6449. The mode of *pasturing sheep*, or of *feeding them* on herbage or roots having been described when treating of these crops, the more general practices of rearing and management of lowland sheep husbandry may be considered as developed. Some peculiar practices and the mode of *fating lambs* will be found in subsequent sections.

SUBJECT. 2. *Of the Rearing and general Management of Sheep on Hilly and Mountainous Districts, or what is generally termed Store Sheep Husbandry.*

6450. The best *store farmers* in Britain, are unquestionably those on the Cheviot hills, which border the two kingdoms, and an account of their management may be considered as applicable to the mountainous districts of the whole kingdom. It is indeed applied by the migrations of the Cheviot and Teviotdale farmers, both in the North Highlands, on the Sutherland estate, and in Wales. No regular system of store farming, as observed by Napier, (*Treatise on Store Farming*), appeared previously to his

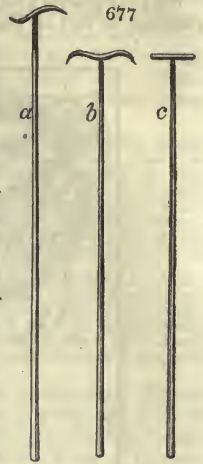

own; and accordingly from this work, and an excellent account published in the *Supplement to the Encyclopædia Britannica*, we have extracted what follows.

6451. *A general idea of the extent and nature of a store farm* may be obtained by referring to that of Thirlstane in Ettrick forest, a plan of which (*fig. 678.*) is given by

678



Captain Napier. It contains one thousand six hundred and fifty-one acres; of which one thousand four hundred and sixty-four acres are in open hill pasture, seventy in plantation, forty in arable and meadow, about sixty in six enclosures, and the rest in shepherd's and other cottager's houses, with their allowance of ground for a garden and cow. What distinguishes this farm from most others is the number of stells or small circular enclosures (O) for sheltering and feeding cattle during storms of snow, which are distributed over it; being no fewer than thirty-seven. The advantages of these stells in districts where sheep are liable to be buried by snow, Captain Napier considers very great, and to promote their more general introduction seems to have been one principal inducement for publishing his book. We shall recur to the subject in the following section, when treating of coting, folding, housing, &c.

6452. *In the practice of store farming* the rams are put to the ewes for the purpose of copulation in November, a little earlier or later, according to the prospect of spring food, but seldom before the eighth or tenth of that month. The number of rams required is more or less, according to the extent of the pasture, and their own age and condition. If the ewes are not spread over an extensive tract, one ram to sixty ewes is generally sufficient. It is usually thought advisable to separate the gimmers (sheep once shorn) from the older ewes, and to send the rams to the latter eight or ten days before they are admitted to the former. Notwithstanding this precaution, which retards their lambing season till the spring is farther advanced, ewes which bring their first lamb when two years old, the common period on the best hill farms, are often very bad nurses, and in a late spring lose a great many of their lambs, unless they are put into good condition with turnip before lambing, and get early grass afterwards. This separation, and difference in the time of admitting the rams to the ewes and gimmers, should therefore be always attended to. When a farm under this description of stock has the convenience of a few good inclosures (as in Thirlstane farm for example), still more minute attention is paid by skilful managers. It is not sufficient that the rams are carefully selected from perhaps



double the number, the ewes also are drawn out and assorted, and such a ram appropriated to each lot, as possesses the properties in form or fleece in which the ewes are deficient. In other cases, the best ram and the best lot of ewes are put together. When neither of these arrangements can be adopted, owing to the want of inclosures, it is the practice to send the best rams to the ewes for a few days at first, and those of an inferior description afterwards. In every case, when the farmer employs rams of his own flock, he is careful to have a few of the best ewes covered by a well formed and fine-woolled ram, for the purpose of obtaining a number of good ram-lambs, for preserving or improving the character of his stock.

6453. *The stock through winter*, in a mere breeding farm, consists of ewes and gimmers, which should have lambs in spring; ewe lambs or hogs; and a few young and old rams. All these are sometimes allowed to pasture promiscuously, but on the farms around Cheviot, the ewes and ewe hogs are kept separate, and the ewe hogs are either put on rough pastures, which have been lightly stocked in the latter end of summer, or get a few turnips once a day, in addition to the remains of their summer pasture. The most effectual preventive of the desolating distempers to which sheep of this age are liable, is turnips; and though they should never taste them afterwards, a small quantity is frequently given them during their first winter. After the rams have been separated from the ewes, they are usually indulged with the same feeding as the hogs.

6454. *The ewes, during winter*, are seldom allowed any other food than what their summer pasture affords, except that a small part of it may sometimes be but lightly eaten, and reserved as a resource against severe storms. When these occur, however, as they often do in the Cheviot district, there is little dependence on any other food than hay. When the snow is so deep as completely to cover the herbage, about two stones *avoirdupois* of hay are allowed to a score of sheep daily, and it is laid down, morning and evening, in small parcels on any sheltered spot near the house, or under the shelter of *stalls* or clumps of trees, on different parts of the farm.

6455. *The ewes in March*, at least the gimmers or young ewes, are commonly allowed a few turnips once a day, on farms on which there is any extent of arable land; which are either carted to their pastures, or eaten on the ground, by bringing the sheep to the turnip field through the night. A part of the field, in the latter case, is cut off by nets, or by hurdles, which inclose the sheep in the same way as if they were intended for fattening. When they are ready to drop their lambs, they are no longer kept on the turnip field, and get what turnips may be left on their pastures. But it is seldom that the turnips last so long, though it is desirable to have a few remaining to be given to the weakest ewes, or to such as have twins, in a separate inclosure.

6456. *A few days before the time of lambing*, the ewes are collected for the purpose of being udder-locked. The sheep are raised upon their buttocks, their backs next to the operator, who then bends forward and plucks off the locks of wool growing on or near the udders, for the purpose of giving free access to the expected lambs. At the same time he ascertains the condition of the ewes, and marks such as do not appear to be in lamb, which may then be separated from the others. This operation is not without danger, and several premature births are usually the consequence. It is therefore not so general a practice as it was formerly, though still a common one on many, if not on most farms.

6457. *The separation of the hogs from the ewes*, where these have been allowed to pasture promiscuously, should always take place at the commencement of the lambing season, and the lowest and finest part of the pasture exclusively appropriated to the nursing ewes. On the Cheviot hills the hogs are generally pastured apart on the coarser herbage.

6458. *The lambing season* commences with the first or second week of April, according to the time at which the rams were admitted; and such as have twins, generally lamb among the first of the flock. At this season, the most constant attention is indispensable on the part of the shepherds, both to the ewes in labor, and to the newly dropped lambs. Though the Cheviot ewes are not so liable to losses in parturition, as some larger breeds which are in higher condition, and though they make good nurses, unless they are very lean, and their food scanty, yet, among a large flock, there are always a number that need assistance in lambing, and in a late spring not a few who have not milk sufficient for their lambs, particularly among the gimmers or young ewes. A careful shepherd at this time always carries a bottle of milk along with him, which he drops from his own mouth into that of the lamb that may need it; brings the ewes that have little milk to a better pasture, or to turnips, and confines such as have forsaken their lambs in a small pen, or barrack as it is called, temporarily erected in some part of the farm-steading. The same confinement is necessary when it is wished to make a ewe that has lost her own lamb, nurse that of another ewe that has had twins, or that has perished in lambing, or is from any other cause incapable of rearing her lamb. The ewe after being shut up a few hours with the strange lamb, usually admits it to the teat, and ever after treats it as her own; though sometimes a little deception is necessary, such as covering the stranger with the skin of her own lamb. At this important season, an inclosure of rich early grass, near the shepherd's cottage, is of vast advantage. Thither he carries the ewes and twins, such as have little milk; those that have been induced to adopt another's offspring; and generally, all that need to be frequently inspected, and are in want of better treatment than the rest of the flock. (*Supp. &c.* 178.)

6459. *Castration* is performed in the male lambs when a few days old, the ewe lambs

are never spayed: mild weather is chosen, and the operation performed in a fold on small quantities at a time.

6460. *The late lambing ewes* are separated from the ewes and lambs at the end of the lambing season, and kept by themselves, that they may be more under the eye of the shepherd, than if scattered over all the pasture. It is desirable to allow them fine grass for a few weeks after lambing, that their lambs may come to be nearly equal to the rest of the flock when weaned; or if they are too late for this, that they may get ready for the butcher by the month of August, beyond which period the ewes must be much injured by suckling them. (*Supp. &c.*, art. *Agr.* 179.)

6461. *Washing*, in store-farming, is performed when the wool has risen sufficiently, which is easily known by the appearance of a new growth. The barren sheep are brought to the washing pool. Sometimes they are hand-washed by men who stand in the pool, and have the sheep forced towards them singly; but more commonly, the Cheviot sheep, especially if the flock be numerous, are compelled to leap into the pool in a body for three or four times successively; and it is desirable that they should have room to swim a little, and come out on a green low bank on the opposite side. After being washed, the sheep are preserved as far as possible from rubbing against earthen dykes or banks, and from lying down on any dirty spot which might soil their wool. (*Supp. &c.*)

6462. *Marking*, as in general sheep-farming (6447.), takes place before the shorn sheep are turned out to pasture; they are marked, commonly with the owner's initials, by a stamp, or *boost* in provincial language, dipped in tar heated to a thin fluid state, and it is not unusual to place this mark on different parts of the body, according to the sheep's age.

6463. *The weaning of lambs* takes place when they are about three months old, sometimes sooner. When the ewes are gathered to be washed or shorn, the ewe lambs to be kept for supplying the place of the old ewes occasionally sold, are stamped in the same way as the ewes. The store-lambs are sent to some clean grassy pasture for a few weeks; and where the farm does not afford this accommodation, they must be *summered*, as it is called, at a distance. Several farms near Cheviot, and on the Lammermuir hills in Berwickshire, are appropriated to this purpose, the owner of the lambs paying so much a-head for six or eight weeks. In the mean time the ewe hogs, or gimmers as they are denominated after shearing, have joined the ewe stock, and the lambs, when brought home, go to the pasture which they had occupied. Wherever they may be kept in winter, it is always desirable to allow them a few turnips, along with a full bite of coarse herbage.

6464. *The practice of milking ewes* after the separation of the lambs is still continued in a few places. This very objectionable management is generally continued for six or eight weeks. The value of the milk of each ewe for this time, may not exceed from one shilling to one shilling and six-pence a-head and the sheep are injured to at least three times that amount, independent of accidents at the milking fold. The cream is separated from the ewe milk, and made into butter for smearing, and the milk itself mixed with cow milk, and converted into cheese. The most skilful store-masters, however, have either laid aside milking, unless for a few days, or have shortened the period to two or three weeks.

6465. *The selection of the crones or old ewes* to be sold, generally takes place in September or October, when they are sold to the feeder, and replaced by lambs of the current year. On the lower hills, ewes are generally disposed of after having lambed three seasons, or under four and a half years of age. In some situations they are kept on till a year older; but when they are purchased, as they usually are, to be kept another year on lower grounds, it is commonly for the interest of the store-farmer, to sell them when still in their full vigor. Skilful managers do not content themselves with drafting them merely according to age; and as there is no disadvantage in keeping a few of the best another year, they take this opportunity of getting rid of such of the flock of other ages as are not of good shapes, or are otherwise objectionable. As soon as the ewes to be disposed of are drawn from the flock, they are kept by themselves on better pasture, if the circumstances of the farm will admit of it. Sometimes they are carried on till they are fattened, and turnips are often purchased for them at a distance. When this is the case, it is not thought advisable to keep them longer, than till between Christmas and Candlemas, as an old ewe does not improve like a wether in the spring months. (*Supp. &c.*)

6466. *The salving or smearing of sheep* is an operation scarcely known in England, and not practised by the Welsh: some store-farmers in the milder districts of the northern counties, consider it unnecessary, but in all very cold situations it is still employed. The object of this operation is to destroy vermin, to prevent cutaneous diseases, and to promote the warmth and comfort of the animal during the storms of the ensuing winter. It is not necessary with sheep kept on low grounds, and well fed during winter, and it may occasionally be omitted for one season, particularly with old sheep, without material injury; but notwithstanding the ridicule that speculative writers have attempted to throw upon the practice, it is almost universally considered necessary and beneficial on high exposed situations, by the store-farmers of the border hills. Smear'd wool does not sell so high as white wool, but the greater weight of the former more than compensates for the difference in price. (*General Report of Scotland*, vol. iii.) The season of salving or smearing is usually towards the end of October or beginning of November, before the rams are sent to the ewes. The most common materials are butter and tar, mixed in different proportions; a greater proportion of tar being employed for the hogs or young sheep than for the older ones. The proportions are also different on almost every farm,

and more tar is thought to be necessary, according to their greater elevation and exposure. In Roxburghshire, some mix two gallons of tar with thirty-six pounds of butter, as a sufficient allowance for three score of sheep, but for the same number it is more common to allot only one stone (twenty-four pounds) of butter, to two gallons of tar. (*Roxburghshire Report*, p. 155.) A common proportion of late has been about fourteen pounds of butter, to two Scotch pints of tar (nearly  $3\frac{1}{2}$  quarts English wine measure), for ewes, and eleven pounds to the same quantity of tar for hogs. This mixture should smear from twenty to twenty-five of each, which is the number one man can do in a day. The expense, according to present prices, will be about nine-pence for each sheep: and the articles, such as oil, palm-grease, tallow, &c., have been recommended in place of butter; but none of them are in general use, and the only addition that is approved of is a little butter-milk. The butter is slowly melted and poured upon the tar, and the mixture is constantly stirred till it becomes cool enough for use. The wool is accurately parted into rows from the head to the tail of the animal, and the salve is carefully spread upon the skin with the point of the finger at the bottom of each row. (*Sup. En. Brit. art. Agr.* 180.)

6467. *The care of sheep during storms* is a business requiring constant attention. In storms of wind and rain, or what are called *black storms* by the shepherds, the sheep will, in a great measure, take care of themselves, by pasturing in situations naturally sheltered. All that is required from it here is to remove any of the more delicate into a covered fold or sheep house; though such conveniences are seldom to be found on mountain farms. But in a storm of snow the natural shelter to which the sheep have recourse, becomes the great receptacle of drift, and the harbinger of death to the flock. It is in such situations that Captain Napier purposes to place his stalls, or circular folds, (*fig.* 678 O), into which the sheep should be driven, or will naturally enter on the commencement of the storm. The round form for these stalls or folds is decidedly preferable to any figure with straight lines, as these invariably harbour drift. Where no artificial shelter is provided immense losses sometimes take place on mountain farms. The sheep are buried many feet deep in the snow; and though the shepherd, with such assistants as he can procure, armed with poles and spades, and aided by the sagacity of his dog, may dig out a few, yet the greater number perish. While the sheep remain in artificial shelters of any kind they must of course be fed; and the only convenient food in such cases is hay, straw, or dried spray—the latter, fortunately, seldom resorted to in this country, which should be put into baskets, or racks. (*fig.* 679.) The Ryeland breed of sheep in Herefordshire, and some of the flocks in the Highlands of Scotland, are put under cover nightly throughout the year: a practice which has probably originated in security, and been continued as matter of convenience and habit.

679



#### SECT. V. *Of the Folding of Sheep.*

6468. *Cotting or folding* is a practice more or less extensively followed with particular breeds and in particular districts, but now generally on the decline. It was formerly thought to be indispensably necessary to the success of the farmer in different districts; but of late a different opinion has prevailed, except in particular cases, and it is considered as merely enriching one field at the expense of another. The practice may however be beneficial where there are downs, heaths, or commons. Folding has been chiefly confined to England, and a small part of Wales and Ireland. The object is to enrich the arable land; but as this is done at the expense of the pasture, it is truly, as Bakewell expressed it, “robbing Peter to pay Paul.”

6469. *The sheep best adapted to the fold* are those of the more active, short-woolled varieties, such as the Norfolk, Wiltshire, and South Down breeds; the heavy long-woolled kinds being less hardy, and some of them, as the Leicesters, much too valuable for a mode of treatment that converts them into dung carriers. The following calculation by Marshal will show, that though, in open lands, the practice may be in some cases tolerated on the ground of conveniency or expediency, it can possess no recommendation as a profitable mode of management in other circumstances.

6470. *This morning* (September 22d, 1780), measured a sheep-fold, set out for six hundred sheep, consisting of ewes, wedders, and grown lambs. It measures eight by five and half rods, which is somewhat more than seven rods to one hundred, or two yards to a sheep.

6471. *August 29, 1781.* Last autumn made an accurate experiment, on a large scale, with different manures for wheat, on a sandy loam, summer fallowed. Part of an eighteen acre piece was manured with fifteen or sixteen loads of tolerably good farm-yard dung an acre; part with three chaldrons of lime an acre; the rest folded upon with sheep twice; the first time at the rate of six hundred sheep to a quarter of an acre (as in first minute), the second time thinner. In winter and spring, the dung kept the lead; and now, at harvest, it has produced the greatest burden of straw. The sheep-fold kept a steady pace from seed-time to harvest, and is now evidently the best corned, and the cleanest crop. The

lime, in winter and spring, made a poor appearance, but after some showers in summer, it flourished much, and is now a tolerable crop, not less, I apprehend, than three quarters of an acre.

6472. *From these data* the value of a sheep-fold, in this case, may be calculated. It appears from the first minute, that one hundred sheep manured seven square rods daily. But the second folding was thinner; suppose nine rods, this is, on a par of the two foldings, eight rods a day each folding. The dung could not be worth less than half a crown a load; and the carriage and spreading ten shillings an acre; together fifty shillings an acre; which quantity of land the hundred sheep teathed twice in forty days. Supposing them to be folded the year round, they would, at this rate, fold nine acres annually; which, at fifty shillings an acre, is twenty-two pounds ten shillings a hundred, or four shillings and sixpence a head. In some parts of the island, the same quantity of dung would be worth five pounds an acre, which would raise the value of the teathe to nine shillings a head; which, at two-pence a head a week, is more than the whole year's keep of the sheep. It does not follow, however, that all lands would have received equal benefit with the piece in consideration; which, perhaps, had not been folded upon for many years, perhaps never before; and sheep folds, like other manures, may become less efficacious the longer it is used on a given piece of land. (*Marshal's Rural Economy of Norfolk*, vol. ii. p. 29.)

6473. *To fold on land in tillage all the year* is nearly impracticable; and where it could be done, the manure would be greatly diminished in value from rain and snow, to say nothing of the injury to the sheep themselves. So that the estimate of four shillings and sixpence, or nine shillings a head, is evidently in the extreme.

6474. *According to Arthur Young, (Farmer's Calendar)*, the same land will maintain one-fourth more stock when the animals are allowed to depasture at liberty, than when confined during the night in folds. The injury to the stock themselves, though it is not easy to mention its precise amount with any degree of accuracy, cannot well be doubted, at least in the case of the larger and less active breeds, when it is considered that they are driven, twice a day, sometimes for a distance of two, or even three miles, and that their hours of feeding and rest are, in a great measure, controlled by the shepherd and his boy. When they are kept in numerous parcels, it is not only driving to and from the fold that affects them, but they are in fact driving about in a sort of march all day long, when the strongest have too great an advantage, and the flock divides into the head and tail of it, by which means one part of them must trample the food to be eaten by another. All this points the very reverse of their remaining perfectly quiet in small parcels.

6475. *The result of Parkinson's experience* is "that were the pasture sheep of Lincolnshire to be got into a fold once a-week, and only caught one by one, and put out again immediately, it would prevent their becoming fat." (*Parkinson on Live Stock*, vol. i. p. 367.) The only sort of folding ever adopted to any extent by the best breeders is on turnips, clovers, tares, and other rich food, where the sheep feed at their ease, and manure the land at the same time.

6476. *Folding in littered yards* is described by Dickson (*Complete Farmer*, art. *Sheep*) as combining all the advantages of folding on arable lands without any of its disadvantages. By this practice the sheep are confined at night in a yard well and regularly littered with straw, stubble, or fern; by which means the flock is said to be kept warm and healthy in bad seasons, and at the same time a surprising quantity of manure accumulated. A great improvement on this method, it is said, would be, giving the sheep all their food (except their pasture) in such yard, viz. hay and turnips: for which purpose they may be brought up not only at night, but also at noon, to be baited; but if their pasture be at a distance, they should then, instead of baiting at noon, come to the yard earlier in the evening, and go out later in the morning. This is a practice, he says, that cannot be too much recommended; for so warm a lodging is a great matter to young lambs, and will tend much to forward their growth: the sheep will also be kept in good health; and, what is a point of consequence to all farms, the quantity of dung raised will be very great. If this method is pursued through the months of December, January, February, March, and April, with plenty of litter, one hundred sheep will make a dunghill of at least sixty loads of excellent stuff, which will amply manure two acres of land; whereas one hundred sheep folded (supposing the grass dry enough) will not, in that time, equally manure an acre.

6477. *Our opinion of this sort of folding*, so warmly recommended by Sir J. Sinclair and A. Young, in the husbandry of Scotland, coincides with that of a very superior judge, who says, "that such a method may be advantageous in particular cases, it would be rash to deny; but generally, it is not advisable, either on account of the sheep, or any alleged advantage from the manure they make. As to the sheep, this driving and confinement, especially in summer, would be just as hurtful as folding them in the common way, and it has been found that their wool was much injured by the broken litter mixing with the fleece in a manner not to be easily separated: besides, now that it is the great object of every skilful breeder to accelerate the maturity of his sheep, as well as other live stock; among other means, by leaving them to feed at their ease, and if circumstances permit, in small parcels; such a practice as this can never be admissible in their management; and with regard to manure, there can be no difficulty in converting into it, any quantity of straw, stubble, and fern, by cattle fed in fold-yards, on green herbage in summer, and turnips, or other succulent food, in winter; while the soil, especially if it be of a light porous quality, is greatly benefited both by the dung and treading of sheep, allowed to consume the remainder of both sorts of food on the ground. It is true, that the dung of sheep has been generally supposed to be more valuable than that of cattle, but accurate experiments have not been made to determine the difference in this respect, among these and other polygastric animals. The greater improvement of pastures by sheep, is probably owing as much to their mode of feeding, as to the richer quality of their dung." (*Sup. E. Brit. Agr.*)

#### SECT. VI. *Of Fattening Sheep and Lambs.*

6478. *The subject of fattening sheep* may be considered in regard to the age at which fattening is commenced, the kind of food, and the manner of supplying it.

6479. *The age at which sheep are fattened* depends upon the breed, some breeds, such as the Leicester, maturing at an earlier age than others, under the same circumstances; and also in the abundance and quality of the food on which they are reared; a disposition to early obesity, as well as a gradual tendency towards that form which indicates a propen-

sity to fatten, being materially promoted by rich food, while the young animals are yet in a growing state. On good land, the Leicester wethers are very generally brought to a profitable state of fatness before they are eighteen months old, and are seldom kept for fattening beyond the age of two years: the Highland breeds, on the other hand, though prepared, by means of turnips, a year at least sooner than they could be in former times, usually go to the shambles when from three to four years old. The ewes of the first description are commonly fattened after having brought lambs for three seasons, that is, after they have completed their fourth year, and those of the small breeds, at from five to seven years of age, according to circumstances. (*Sup. E. Brit. art. Agr.*)

6480. *The kinds of food on which sheep are fattened, are good pastures, permanent or temporary, herbage crops, as clovers, tares, &c., turnips, and other roots; and linseed cake, grains, or other edible refuse of the oil manufactory, brewery, and distillery.*

6481. *The mode of feeding on rich pastures, herbage, and turnips, has already been described when treating of these crops, and it remains only to notice the modes of using grains and oil cake. These and also bran, oats, pease, and other grains and meals, whether given in winter or summer, should always be accompanied with pasture or dry food of some sort, especially hay. All food of this sort should be given in moveable troughs, divided in the middle, so that the sheep may feed on each side, with a sloping roof over them, so as to cover the sheep's heads and necks while feeding, as wet is not only prejudicial to the sheep, but spoils the food. A rack for hay, fixed over the trough, might probably be made to answer in this intention, while it would be very convenient for holding that material, and preventing waste. The whole should be fixed on wheels, and be made to stand steady, and a sufficient number for the quantity of sheep, be always in readiness. In the fattening of wethers, the use of barley meal, with grass or some other sort of green food, has likewise been found highly beneficial, and when it can be procured at a reasonable rate, should not be neglected, as it is quick in rendering them fat, and the mutton is excellent. A pound of oil cake, or of meal per day, with hay, or turnips, for each crone or wether, is reckoned a fair allowance in Lincolnshire. In the report of that county, several instances of oil cake feeding are given, by which it appears that that sort of food fattens in a shorter time than any other, is the most suitable food for fattening old sheep, and a rapid promoter of the growth of the wool.*

6482. *As general rules for fattening sheep, as well as other animals, it should be made a rule never to allow them to lose flesh from the earliest age, till they are sent to the butcher; that it is found of much advantage with a view to speedy fattening, as well as to the economy of food, to separate a flock into divisions, corresponding with its different ages, and the purpose of the owner as to the time of carrying them to market; and that the change from the food of store to fattening stock, from that which is barely capable of supporting the condition which they have already attained, to that which is adapted to their speedy improvement in fattening, ought to be gradual and progressive. Thus, very lean sheep are never, in good management, put to full turnips in winter, nor to rich pastures in summer; they are prepared for turnips in good grass land; often on the after-grass of mown grounds, and kept on second year's leys, and afterwards a moderate allowance of turnips, if they are fattened on pastures. It is a common practice, in the instance of the Leicesters, to keep all that are not meant for breeding always in a state of fatness, and after full feeding on turnips through winter and spring, to finish them on the first year's clover early in summer, when the prices of meat are usually the highest.*

6483. *The fattening of lambs during summer, requires nothing more than keeping their mothers and them on the richest and best pasturage, and supplying such artificial food as the situation, season, or other circumstances may require; but the fattening of lambs during winter and spring, requires attention to three things, the breed, or if any breed be used indifferently, the period of dropping, the lamb house, and the feeding.*

6484. *With respect to the breed, as the sheep will take the ram at any season, any variety may be so managed as to drop their lambs at any period of the year, but it is found by experience, that the Dorsetshire sheep is easiest made to yearn, and therefore this is the sort generally employed in Middlesex for rearing what is called house lamb, for the metropolis. The selection of the rams for breeding the lambs to be house fed, is, according to Middleton, founded on the following circumstances: the sucklers, salesmen, and butchers of London, are aware that such lambs as have sharp barbs on the inside of their lips, are certainly of a deep color after being butchered; and all those whose barbs are naturally blunt, do as certainly produce fair meat. This knowledge has been the occasion of many lambs of the latter kind being kept for rams, and sent into Dorsetshire expressly for the purpose of improving the color of the flesh of house lambs, the issue of such rams can generally be warranted fair, and such meat always sells at a higher price; hence arose the mistaken notion that Middlesex rams were necessary to procure house lambs.*

6485. *A lamb-house may be any close shed, cow-house, or other spare house, or, even on a small scale, a roomy pigstye. But they are built on purpose by the extensive dealers in this article; and one to suckle from one hundred and sixty to one hundred and eighty lambs at a time, should be seventy feet long, and eighteen feet broad, with three coops of different sizes at each end, so constructed as to divide the lambs according to*

their ages. A plan of a sheep-house, combining also a lamb-house, is given by Kraft in his *Rustic Designs*. It is wholly built of unbarked spars, or young fir-trees. The plan (*fig. 680.*), contains four close apartments with doors for the lambs (*a*), and four others with racks for the sheep (*b*). The elevation (*fig. 681.*) shows a gallery (*c*), which sur-

680

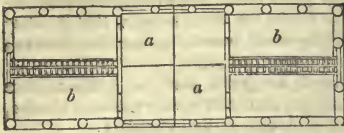

681



rounds the building, and is used as a passage for viewing the sheep, handling them with the crook, and at night for the perambulations of a watch-dog. The roof being twenty feet from the floor, the interior is abundantly airy, which for sheep is an important object. Another design in the same work (*fig. 682.*), is accompanied by an elegant Italian watch-tower, with apartments therein for the shepherd.

6486. *The economy of the suckling-house* is as follows: The sheep which begin to lamb about Michaelmas are kept in the close during the day, and in the house during the night, until they have produced twenty or thirty lambs. These lambs are then put into a lamb-house, which is kept constantly well littered with clean wheat straw; and chalk, both in lump and in powder, is provided for them to lick, in order to prevent looseness, and thereby preserve the lambs in health. As a prevention against gnawing the boards, or eating each other's wool, a little wheat straw is placed, with the ears downwards, in a rack within their reach, with which they amuse themselves, and of which they eat a small quantity. In this house they are kept, with great care and attention, until fit for the butcher.

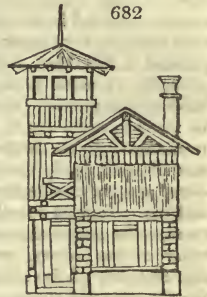

682

6487. *The mothers of the lambs* are turned, every night at eight o'clock, into the lamb-house to their offspring. At six o'clock in the morning, these mothers are separated from their lambs, and turned into the pastures; and at eight o'clock, such ewes as have lost their own lambs, and those ewes whose lambs are sold, are brought in and held by the head till the lambs, by turns, suck them clean: they are then turned into the pasture; and at twelve o'clock, the mothers of the lambs are driven from the pasture into the lamb-house for an hour, in the course of which time each lamb is suckled by its mother. At four o'clock, all the ewes that have not lambs of their own are again brought to the lamb-house, and held for the lambs to suck; and at eight, the mothers of the lambs are brought to them for the night.

6488. *This method of suckling* is continued all the year. The breeders select such of the lambs as become fat enough, and of proper age (about eight weeks old), for slaughter, and send them to markets during December, and three or four succeeding months, at prices which vary from one guinea to four, and the rest of the year at about two guineas each. This is severe work for the ewes, and some of them die under excess of exhaustion. However, care is taken that they have plenty of food; for when green food (*viz.* turnips, cole, rye, tares, clover, &c.) begins to fail, brewer's grains are given them in troughs, and second-crop hay in racks, as well to support the ewes, as to supply the lambs with plenty of milk; for, if that should not be abundant, the lambs would become stunted, in which case no food could fatten them. (*Middlesex Report*, p. 355.)

SECT. VII. *On the probable Improvement which may be derived from Crosses of the Merino Breed of Sheep.*

6489. *The Merino*, or Spanish variety of the *Ovis Aries*, is supposed by Rozier and other French writers, to have been originally imported from Africa to Spain. It is, however, at least as probable, that they are indigenous to that country, or if originally imported, that they have become modified to what they are, by the soil and climate. Merinos first attracted attention in this country in 1764, in consequence of the reports of travellers, and a letter by Don John Bowley to Peter Collinson, published in the *Gentleman's Magazine* for that year. A few were imported in 1788, and more in 1791, and placed on the King's farm at Windsor, under the care of Sir Joseph Banks, who was then constituted His Majesty's shepherd. The first sale of stock was made in 1800; and from these, a flock imported from Spain in 1801, by Lord Somerville, and some other importations by different persons subsequently, have sprung all the Merinos and Merino rams in the empire. Since that period, a number of eminent breeders and scientific agriculturists have cultivated this breed both alone and by crossing, but especially Dr. Parry and Lord Somerville; and though the utility which its introduction may ultimately prove to the country can by no means be estimated at present, that it has already done much good by directing the public attention to the subject, there can be no

doubt; and many are of opinion, that by it the fleeces of our short-wooled sheep may be so improved as to render them fit substitutes for imported Spanish wool.

6490. *Dr. Parry's experiments* with the Merino breed were begun nearly at the same time with the King's. His farm was elevated, exposed, and unfit for any other purpose than breeding; and he fixed on the Ryeland breed, as one of the finest woolled varieties of British sheep, for crossing with Merino rams. His only object was the improvement of the fleece.

6491. *The effect of the fourth cross of the Merino ram*, according to the opinion of sheep cultivators on the continent, on any breed of ewes, however coarse and long in the fleece, will be to give progeny with short wool equal to the Spanish. Of the truth of this proposition, however, Dr. Parry justly expresses some doubts, derived from his own experience and that of others. But it is certain, he adds, that one cross more will, in most cases, effect the desired purpose. If we suppose, he says, the result of the admixture of the blood of the Merino ram to be always in an exact arithmetical proportion, and state the native blood in the ewe as 64; then the first cross would give  $\frac{32}{64}$  of the Merino; the second  $\frac{16}{64}$ ; the third  $\frac{8}{64}$ ; the fourth  $\frac{4}{64}$ ; the fifth  $\frac{2}{64}$ ; the sixth  $\frac{1}{64}$ , and so on. In other words, the first cross would leave thirty-two parts in sixty-four, or half of the English quality; the second sixteen parts, or one-fourth; the third eight parts, or one-eighth; the fourth four parts, or one-sixteenth; the fifth two parts, or one-thirty-second; the sixth one part, or one-sixty-fourth, and so on. Now, if the filaments of the Wiltshire, or any other coarse wool, be in diameter double that of the Ryeland, it is obvious, that, according to the above statement, it would require exactly one cross more to bring the hybrid wool of the former to the same fineness as that of the latter. This, he believes, very exactly corresponds with the fact. The difference between one-eighth and one-sixteenth is very considerable, and must certainly be easily perceived, both by a good microscope, and in the cloth which is manufactured from such wool. In the latter method, he adds, "it certainly has been perceived; but I have hitherto had no opportunity of trying the difference by the former. The fifth cross, as I have before observed, brings the Merino-Wilts wool to the same standard as the fourth of the Merino Ryeland." (*Com. to the Board of Agr. vol. v. p. 438.*)

6492. In the *lambing season*, the Ryeland breed are usually cotted, because the newborn lambs are very thinly covered with wool. As January was considered the best lambing season for the produce of the cross, Dr. Parry found cotting was doubly necessary. Every night the flock were well sheltered; and they were allowed, in addition to the pasture which they could pick up in the day-time, linseed jelly, ground oil-cake, or grains, cabbages, rouen, winter and spring vetches, and tares. Salt, he says, I never gave to my flock but once, and that in the following way: A small field of lattermath, cut in September, had been so often wetted, that I despaired of its ever being eaten. While it was putting into the rick, I strewed some salt between the layers; the consequence was, that cows and sheep greedily devoured it, scarcely leaving a single blade. (*Com. to the Board of Agr. vol. v. p. 505.*)

6493. *The shearing of the sheep* was performed in the second week of June, and of the lambs at the end of July. The finer fleeced lambs need not be shorn till the second season. Washing previously to shearing Dr. Parry disapproves of; because the fleece is so thick, that when thoroughly soaked with water, it is very long in drying; and if the weather prove wet and cold, the sheep are evidently much incommoded; he, therefore, recommends cleansing the wool, after being shorn, as in Spain.

6494. *The produce of wool*, considered as the result of Dr. Parry's well conducted experiments, was found to be 14lb. 14oz. per acre, which at 3s. per lb. in the yolk throughout the fleece gives 2l. 4s. 7½d. per acre on land certainly not worth on an average 26 shillings. (*See Comm. to the B. of Agriculture, vol. v.*)

6495. *Lord Somerville's experiments* may be considered as of equal, if not more importance than these of Dr. Parry. His Lordship tried crosses with several short woolled breeds, but was most successful with the South Downs and Ryelands. Morris Birkbeck, a professional farmer of the first order, found that the fleeces of the first cross between Merinos and South Downs, washed, are to the parent South Downs as six to five in weight, and as three to two in value per pound, and believes that the improvement of the wool may go on, without detriment to the carcase, until we shall obtain a breed of sheep with Spanish fleeces, and English constitutions; but this must be the result of careful and judicious selection.

6496. *Merino flocks are now established in most districts* of the empire, and but few years can elapse before their value to the farmer and the country be practically ascertained and evinced. (*See Sir J. Banks in Annals of Agriculture, Com. to B. of Agr. Bath Society's Papers, Dublin Society's Transactions, The Farmer's Magazine, Farmer's Journal. Lord Somerville's, and Dr. Parry's Tracts on Wool and Merinos, and various other works.*)

SECT. VIII. *Of the Anatomy and Physiology of Sheep.*

6197. The *general structure of the sheep* resembles that of the ox very intimately. Sheep however, like the ox, experience considerable variations in size, form, and qualities; resulting from the physical and moral agencies which they become exposed to, under various climates; and also, as whether fostered by cultivation, or left to the natural operations around them. These circumstances have operated on even the bony base of the machine, as we see in the formations of the three horned breed (*Ovis polycerta*, Lin.), natives of the north; in the spiral horned (*O. strepsiceros*, Lin.), which inhabit Wallachia; and the long horned (*Capra ammon*, Lin.), which are found in the countries bordering the Mediterranean: and which have been thought to be the parents of the present cultivated British sheep. Cultivation weakens the otherwise inherent aptitude to retain the original stamp of nature; and we find therefore, that by these means, the original form of the sheep has submitted to vast alterations. We see some of them wholly without horns; we also find that the bony structure is otherwise subjected to our command, by becoming much more slender, though more compact. Accidents are also laid hold on by man to produce particular forms: thus a breed has been cultivated in America, called the ancon or otter breed, remarkable for crooked and deformed legs; which, by continued breeding from specimens that presented this originally accidental deformity, is become now a fixed and permanent breed, valuable for their incapacity to wander or climb. (Dwight.) The dunky or wry-faced breed, is another instance of accidental deformity cultivated into a permanent variety: as the monstrous rump of the Tartarian sheep, and the over-grown tails of some breeds in Turkey, are similar instances in the softer parts of the body.

6498. The *skeleton of the sheep* presents an assemblage of bones, which bears a general resemblance to that of the ox in number and direction. Like him, the head naturally is surmounted by horns springing from the frontal bones. Like him, his frontal sinuses are large and open, and thus liable to the entrance of insects. The skull bones are wide and extended; his orbits are more lateral than central; and his facial angle is about 30 degrees. His vertebral column is the same as the ox, and his ribs also. The extremities descend on the same construction, ending in a divided hoof.

6499. The *visceral and soft parts* are but little dissimilar likewise. His brain is as one two hundredth to the whole body; and his cerebellum to the brain generally, as 1 to 5. The pigment of the eye is of a pale yellowish green, varying occasionally to a blue. The viscera of the chest correspond with the ox; and those of the belly also, the stomachs being the same, and the economy of rumination not differing. The liver, pancreas, and spleen are similar. The penis is taper, vesiculæ seminales wanting, and prostates two.

6500. The *wool of the sheep* is but a crisped hair; and indeed in some foreign varieties, the outer covering is of long hair like that of oxen; while in others the hair and wool are mixed.

SECT. IX. *The Diseases of Sheep.*

6501. The *diseases of sheep* are numerous; for these animals are now so highly cultivated that they may be regarded in some respects as artificial machines: and thus, as a natural consequence, they are subjected to a variety of artificial defects or maladies.

6502. The *rot* is a popular term among shepherds, and includes within its range diseases widely different. We shall not therefore follow the custom of treating the different rots of sheep together; but we shall allow them to fall in their natural order, according to the plan pursued with the diseases of oxen.

6503. The *inflammatory and putrid fever*, popularly known by the names *higham striking*, or *blood striking*, does not differ materially from the same disease in oxen and cows; and is in sheep also sometimes epidemic; appearing by panting, dulness, watery mucus from the nose and eyes; and great redness of all such parts as are usually white.

6504. The *red water*. The inflammatory fever sometimes resolves itself into an universal secretion of serum throughout all the cavities; in which case after a few days, the lymph tinged with blood will come away from the nose and mouth in large quantities. Sometimes after death the bloody serum is found suffused throughout the skin as in the blood striking of skins.

6505. The *clavéau* or *sheep pox* is also another variety of this disease, in which it takes on a pustular form. About the third day small variolæ appear: sometimes they are rather blotches than pustules. The weakness is usually extreme, and the putridity great. This form of the disease is seldom seen with us; but is still known on the continent, where the pastures are very poor and low, and the general keep meagre.

6506. The *treatment* of all these in no wise differs from that directed under the inflammatory putrid fever of the ox. The doses of medicines being about a third of what is directed for them.

6507. *Malignant epidemic or murrain*. Sometimes an epidemic prevails, which greatly resembles the murrain of oxen: in appearances termination and treatment it resembles malignant epidemic of oxen. (6249.)

6508. *Peripneumonia or inflamed lungs, rising of the lights, glanderous rot, hose, &c.* These terms are all modifications of an inflamed state of the viscera of the chest, caught by undue exposure, bad pasturage, and often from over-driving. The cough, the tremblings, the redness of the eyes and nostrils, and the distillation of a fluid from them, with the heavings and hot breath, are all similar to those which characterise the pneumonia or rising of the lights in oxen. We remember to have seen the disease strongly marked in the February of 1808, on a farm in the neighborhood of Streatham; where eleven sheep were attacked almost together, after a very stormy night. They were first affected with a loss of appetite; next with a fixed staid look, which was common to every one. After this, they reeled about, fell backwards, and became convulsed. When seen, five were already dead, whose internal appearances fully confirmed the nature of the disease. The rest recovered by bleeding and drenching, with drenches composed of nitre and tartar emetic. Sometimes, the symptoms of pneumonia do not kill immediately, but degenerate into an ulceration of the lungs; which is then called the *glanderous rot*. This stage is always fatal: the others may, by early attention, be combated by judicious treatment, as detailed under the same disease in oxen.

6509. A *chronic cough* in sheep, when not symptomatic of rot, is always cured by a change of pasturage, particularly into a salt marsh.



6510. *Inflammation of the stomach* occurs from various causes. A common one arises from eating noxious vegetables; and produces the affections termed *tremblings*. It also produces the *grass ill* in lambs; which latter is always accompanied with black, fetid fæces, and is readily removed by an ounce of castor oil; while the former usually yields to half an ounce of oil of turpentine, beaten up with the yolk of an egg. Some herbs (as *Atropa belladonna*,) when eaten produce spasmodic affections, which are called by shepherds the *leaping ill*: in such cases the watery solution of aloes (*Vet. Pharm.* 5916.) in doses of two or three ounces is useful. Daffy's elixir we have also known to be given with good effect.

6511. *The hove, blast, or wind colic*. Sheep are as liable to be distended with an enormous collection within the maw as oxen. An instrument, similar to that invented by Dr. Monro, is also made for them; and when not relieved by these means, the same remedies are applicable, as are directed for oxen. (6259.)

6512. *A wind colic* will also sometimes affect sheep more from the quality than the quantity of what they eat; it is best relieved by an ounce of castor or salad oil with an ounce of gin.

6513. *Inflamed liver, blood rot, or hot yellows*, are liver affections, arising from fever settling in that organ; or from obstructed bile irritating it. Sometimes there are great marks of fever; and at others more of putridity; according to which, treat as may be gathered from ox pathology.

6514. *Jaundice* also now and then occurs, when refer to that disease in oxen. (6268.)

6515. *Dysentery, gall scour, braxy*, are all affections brought on by sudden changes of temperature, or of undue moisture acting with cold pasturage. It is often seen in sultry autumns:—treat as under ox braxy. (6267.)

6516. *Scouring* is the diarrhœa of sheep, and in very hot weather soon carries them off. It should be early attended to, by abstracting the affected, and housing them. The *treatment* is seen under diarrhœa of oxen (6266.), which it closely resembles.

6517. *Pinning, tag-belt, break-share*. The two former are only the adhesion of the tail to the wool, and the excoriation brought on by diarrhœa; the latter is the diarrhœa itself, known to some by this term.

6518. The *rot in sheep* is also called *great rot*, and *hydropic rot*, &c.; but it is more popularly known by the single term of *rot*. Many causes have been assigned for it, as the *fasciola hepatica*, or fluke worm; some particular plants eaten as food; ground eating; snails, and other ingesta: but, as most of the supposed deleterious herbs have been tried by way of experiment, and have failed to produce the disease, so it is attributable to some other cause. Neither is there reason to suppose that the fluke worm occasions it, since we know that the biliary vessels of other animals, as horses, asses, rats, &c., often have them: and above all, because that they are not always present in the rotted subject. From long experience, and the almost invariable effect produced by a humid state of atmosphere, soil, and product; we are warranted in concluding these are the actual and immediate agents: perhaps the saturated food itself is sufficient to do it. The morning dew has been supposed equal to it. Bakewell, when his sheep were past service, used to rot them purposely, that they might not pass into other hands. This he always readily did by overflowing his pastures. But great differences of opinion exist as to the quantity, form, and varieties of moisture, productive of this fatal disease. It is said that land on which water flows, but does not stagnate, will not rot, however moist: but this is contradicted by the experience of Bakewell, who used merely to flood his lands a few times only to rot his sheep. It is also said that they are safe from rot on Irish bogs, salt marshes, and spring flooded meadows, which experience seems to verify. It is also said, that the very hay made from unsound land will rot; but this wants confirmation. When salt marshes are found injurious it is only in such years when the rain has saturated, or rather super-saturated such marshes. That putrid exhalations unaccompanied with moisture can occasion rot wants confirmation also: for these commonly go together, and it is difficult to separate their effects. It is not, perhaps, the actual quantity of water immediately received by land, but the capacity of that land to retain the moisture, which makes it particularly of a rotting quality.

6519. The *signs of rottenness* are sufficiently familiar to persons about sheep. They first lose flesh, and what remains is flabby and pale; they lose also their vivacity. The naked parts, as the lips, tongue, &c., look livid, and are alternately hot and cold in the advanced stages. The eyes look sad and glassy, the breath is fetid, the urine small in quantity and high-colored; and the bowels are at one time costive, and at another affected with a black purging. The pelt will come off on the slightest pull in almost all cases. The disease has different degrees of rapidity, but is always fatal at last. This difference in degree occasions some rotted sheep to thrive well under its progress to a certain stage, when they suddenly fall off, and the disease pursues the same course with the rest. Some graziers know this crisis of declension, as it has been called, and kill their sheep for market at the immediate nick of time with no loss. In these cases, no signs of the disease are to be traced by ordinary inspectors, but the existence of the flukes, and still more, a certain state of liver and of its secretions, are characteristic marks to the wary and experienced.

6520. The *treatment of rot* is seldom successful unless when it is early commenced, or when of a mild nature; a total change of food is the first indication, and of that to a dry wholesome kind: all the farina are good, as the meals of wheat, barley, oats, pease, beans, &c. Carrots have done good mixed with these: broom, burnet, elder, and mellilot, as diuretics, have also been recommended; but it is necessary to observe, that there is seldom any ventral effusion but in the latter stages of the complaint. As long as the liver is not wholly disorganized, the cure may be hoped for a simple removal of the

cause, which has been shown to be a variable temperature, with excessive moisture of pasturage, which may also be aided by such remedies as assist the action of the biliary system; salt acts in this way, and thus salt mashes are good; salt may also be given in the water. Salt appears the principal ingredient in Flesh's patent restorative for sheep, for it states it to be composed of turpentine, sal ammoniac, turmeric, quicksilver, brimstone, salt, opium, alkanet root, bark, antimony, camphor, and distilled water; but of this medley, none of the articles can be in sufficient quantity to prove useful, but the salt. In the more advanced stages of the disease, when the liver has become materially affected, it is prudent to rub the bellies of each sheep with half a drachm of mercurial ointment every other day for a week: give also the following, every morning: watery tincture of aloes, half an ounce, decoction of willow bark, four ounces, nitric acid, twenty-five drops.

6521. *The pelt rot, hunger rot, or naked disease*, is a variety of the former, but with this difference, that whereas the liver in the hydropic rot is principally affected; in this the whole of the chylopoietic viscera are injured; the mesenteric glands are always swollen and obstructed, and from thence arises the emaciation and unhealthy state of all the secretions, by which the rot becomes incapable of receiving nutriment, and falls off, leaving the body bare, and in the last stages the teeth and horns also loosen. Indifferent, unhealthy keep, is a very common cause of this malady, and a contrary course of feeding is the best remedy when the disease has not gone on too long.

6522. *The scab, shab, ray, or rubbers*, are sometimes erysipelatous eruptions, and sometimes they are psoric or mangy ones. In the former instance they are universal and very red, occasioning a great heat and itching, and are thence called the *rubbers*: in such cases, nitre administered quickly relieves, with change of food. The eruptive scab is seldom cured without an external application; either of those directed for mange, lowered to half the strength, will relieve it at once. (See *Vet. Pharm.*)

6523. *Foot rot* sheep have a secretory outlet between the claws peculiar to them, which is liable to become obstructed; their feet are also liable to become injured, and then diseased, from travelling or continued standing on wet soils: but the real foot rot is an endemic affection which sometimes attacks half of the flock. It must be attended to by removing all diseased portions, and then dressing with the thrush paste, or foot rot application, (*Vet. Pharm.* 5885.), and afterwards wrapping up from external exposure.

6524. *Staggers, gid, turnsick, goggles, worm under the horn, sturdy, watery head, and pendro*, are all popular terms for hydatids, or an animal now known as the *tænia globulus*, which, by some unaccountable means, finds its way to the brain, and settles itself there either in some of its ventricles, or more frequently on its substance. Their size varies from the smallest speck to that of a pigeon egg, and the sheep it attacks are usually under two years old. These animals are likewise occasionally found in all the natural cavities of the body.

6525. *The appearances of cerebral hydatids* are, stupidity, a disposition to sit on the rump, to turn to one side, and to incline the head to the same while at rest. The eyes glare, and from oval, the pupils become round. An accurate examination will now usually discover some softness at a particular part of the skull, generally on the contrary side to that on which the animal hangs the head: when no softness of the skull is discernible, the hydatid usually exists in some of the ventricles, and the destruction of the sheep is certain and quick, from the greater disturbance to the functions of the brain; but when it is situated on the surface, it sometimes requires many months to destroy; an absorption of the bone taking place as the hydatid increases, which produces the thinness in the skull opposite to the affected part.

6526. *This disease is not incurable*, as has been supposed, but it is only relieved by a manual operation. In France it has been successfully treated by the application of the actual cautery: a pointed iron, heated red hot, is forced through the skin and skull, to the surface of the brain; the principal nicety of which, is in penetrating the hydatid with the hot iron without wounding the brain itself. In England, some shepherds are very dexterous in *wiring*, which they do by thrusting a wire up the nostrils till it rests against the skull. In the passage of the wire, the hydatid is usually ruptured; others elevate the skull (by means of a trephine, or even a knife) opposite to the softened portion, and extract the hydatid, if possible, whole, which a little care will effect, by drawing it away with a blunt pincer, gently moving it from side to side. Tapping is merely letting out the fluid contents of the hydatid by an awl, which is practised by some shepherds with success; and if the instrument be not thrust too far, the animal is never injured: to avoid which, it is passed obliquely. A well hardened gimlet is a very proper instrument, with which the skull is easily penetrated, and an opening by the twisting of the instrument is made, sufficiently large in the hydatid itself, to discharge its contents, which is all that is sufficient to ensure its destruction, and which, if no others exist, is followed by immediate recovery.

6527. *Frontal worms*. Sheep are observed to gather together, with their noses thrust inwards to avoid the attack of the *æstrus ovis*, or fly, that lays its eggs on the inner margin of the nose, which, having become hatched, the larva creep up into the frontal and maxillary sinuses, to the torment of the sheep. The continental shepherds trepan an opening into these cavities, and effect their removal; but our shepherds have not succeeded in the operation.

6528. *Fluke worms* are a parasitic animal, found in the biliary sinuses, not only of the sheep, but of the horse, ass, goat, deer, &c., and whose existence is rather a consequence than a cause of morbidity.

6529. *The diseases of lambs* are confined to indigestion, and eruption of secretive matter: the former shews itself in colic, which is relieved as in sheep, and also by diarrhœa, to be likewise cured by the means detailed for them; the latter is more obstinate, and begins on the rump, gradually extending along the chine, and when it becomes more universal, it usually destroys. The cure consists in giving daily drinks of half a drachm of cream of tartar, and one drachm of sulphur, in four ounces of chamomile decoction. Anoint also with mild mercurial ointment and Turner's cerate in equal quantities.

## CHAP. VII.

*The Swine.* — *Sus Scrofa*, L.; *Cochon*, Fr.; *Schwein*, Ger.; *Puerco*, Span. and *Porco*, Ital.

6530. *Of swine* there are several species, but none in general domestication, or much used as food when taken wild, excepting the common sort, which includes the wild hog or wild boar, the original stock of our domestic breed, the European hog, and the Chinese hog. The common hog is found either in a wild or domestic state, in almost

all the temperate parts of Europe and Asia; but it is not met with in the most northern parts of these continents. It is found in many parts of Africa. Mr. Pennant asserts, that the wild boar was formerly a native of this country, and hunted from the middle of November to the beginning of December; and it is asserted by Fitz-Stephens, that the vast forest which in his time grew on the north side of London, was the retreat of stags, wild-boars, and bulls.

6531. *The wild-boar* (fig. 683.) inhabits woods, living on various kinds of vegetables, such as roots, masts, acorns, &c. It also occasionally devours animal food: it is in general considerably smaller than the domestic hog, and is of a dark brindly-grey color, sometimes blackish; but when only a year or two old, it is of a pale



683

red or dull yellowish-brown cast; and when quite young, it is marked with alternate dusky and pale stripes, disposed longitudinally on each side the body. Between the bristles, next the skin, is a finer or softer hair, of a woolly or curling nature. The snout is somewhat longer in proportion than that of the domestic animal; but the principal difference is in the superior length and size of the tusks, which are often several inches long, and capable of inflicting the most severe and fatal wounds. The hunting of the wild boar forms one of the principal amusements of the great in some parts of Germany, Poland, &c. and is a chase of some difficulty and danger, not on account of the swiftness, but the ferocity of the animal. Wild boars, according to Buffon, which have not passed the third year, are called by the hunters beasts of company, because previous to that age they do not separate, but follow their common parent. They never wander alone till they have acquired sufficient strength to resist the attacks of the wolf. These animals, when they have young, form themselves into flocks, and it is upon this alone that their safety depends. When attacked, the largest and strongest front the enemy, and by pressing all round against the weaker, force them into the centre. Tamed bears have afforded subjects of barbarous sport in most parts of Europe, from the earliest period, and though bear baiting is happily no longer in vogue in Britain, as it still is in Spain; yet the animal is taught various ludicrous movements, which are exhibited to the country people, by itinerant showmen. When real bears cannot be got, boys are metamorphosed and taught to imitate them. (fig. 684.)

684



6532. *Of the tame hog*, white is the most general color; but other colors are often intermixed in various proportions. In some respects, the hog seems to form an intermediate link between the whole and the cloven-footed animals; in others, he seems to occupy the same rank between the cloven-footed and digitated. Destitute of horns; furnished with teeth in both jaws; with only one stomach; incapable of ruminating; and producing at one birth a numerous progeny: the union of these faculties confers on the hog a remarkable peculiarity of character. He does not, like other animals, shed his fore-teeth, and put forth a second set, but retains his first set through life.

6533. *Hogs seem to enjoy none of the powers of sensation in eminent perfection.* They are said to hear distant sounds; and the wild boar distinguishes the scent of the hunter and his dogs, long before they can approach him. But so imperfect is their feeling, that they suffer mice to burrow in the fat of their backs without discovering any uneasiness, or appearing even to notice it. In their taste they show a singular degree of caprice. In the choice of herbs they are more delicate than any other herbiferous animal, yet devour the most nauseous and putrid carrion with more voracity than any beast of prey. At times they do not scruple to eat their own young; they will even mangle infants out of desperate voracity.

6534. *Hogs are remarkable for the smallness of their eyes*: hence a person whose eyes are very diminutive, and deep sunk in his head, is said to be pig-eyed. The form of the hog is inelegant, and his carriage is equally mean as his manners. His unwieldy shape renders him no less incapable of swiftness and sprightliness, than he is of gracefulness of motion. His appearance is always drowsy and stupid. He delights to bask in the sun, and to wallow in the mire. An approaching storm seems to affect his feelings in a very singular manner. On such an occasion, he runs about in a frantic state, and utters loud shrieks of horror. Hogs are infested with lice, and are subject to many disorders, such as the scurvy, scab, and scrofula. The sow brings forth in the beginning of the fifth month after conception, and she has often two litters in a year. She generally produces a numerous progeny at a birth; but her first litter is less numerous than those that follow. Hogs, when suffered to see the natural term of life, live from fifteen to thirty years. Their size and strength continue to improve till they are five or six years old.

6535. *Tame hogs are often very troublesome* in cultivated grounds, ploughing them up with their snouts, and thus entirely frustrating the labors of the agriculturist. Worms, the wild carrot, and other roots, are the objects of their search. The wild boar having a longer and stronger snout than the domestic variety, digs deeper, and continues his furrow nearly in a straight line. The inhabitants of America find the hog very beneficial in clearing their lands of rattlesnakes and other serpents, upon which he constantly preys, without apparently suffering any injury.

6536. *The hog is, in a very considerable degree, beneficial to mankind.* His flesh is pleasant, substantial, and nutritious. It affords numberless materials for the table of the epicure; among these is brawn, which seems peculiar to England. Pork takes salt better than the flesh of any animal, and is, in consequence, preserved longer, and always makes an important article in naval stores. The lard of the hog is essential to the cook and confectioner; it is used in various medical preparations, and is compounded by the perfumer into pomatums. The bristles are made into brushes, and are, moreover, of great use to the shoemaker. The skin is worked into coverings for pocket-books, and other articles.

6537. *The hog in British farming is in general viewed as a subordinate species of live stock, and chiefly valuable as consuming what would otherwise be lost.* There are, however, swine husbandmen who keep large herds to advantage, especially millers, brewers, distillers, and dairymen, to whom they are an object of importance; and return, for the offal they consume, a greater weight of meat, according to some double the weight, than could be obtained from cattle. In those parts where potatoes are raised as a fallow crop, much beyond the demand for them as human food; as is the case in particular in Ireland, and the west of Scotland, the rearing and feeding of swine, the most of them sent to a distance in the state of bacon and pickled pork, is a branch of management on which great dependence is placed for the payment of their rents and other charges. The prolific nature of this animal, however, rendering it so easy to increase the supply beyond the demand, the price of swine flesh varies more than that of any other sort of butcher's meat, and their culture can never be so much depended on by the general farmer as that of cattle or sheep. A writer in the *Farmer's Magazine* observes, that the swine are the only variety of granivorous animals that can be fed upon the offal of grain, or such articles as would otherwise go to waste about a farm-steading. Since the erection of threshing machines, a much greater quantity of light grain is beat from the straw, than was gained when the flail was employed. To use this extra quantity to advantage becomes an important concern to the occupiers of land; and this writer thinks that the using of it in raising and supporting swine is by far the most profitable mode of consuming an article, which, in other respects, is comparatively of little value.

#### SECT. I. *Of the Varieties of the common Hog.*

6538. *The domesticated European variety of the common hog (fig. 685.) is too well known to require any description.*



6539. *The Chinese hog (fig. 686.) is distinguished from the common, by having the upper part of its body almost bare, its belly hanging nearly to the ground; its legs are very short, and*



its tail still more disproportionately short. The flesh of this variety is whiter and more delicate. The color is commonly a dark grey. It abounds in China, and is diffused through New Guinea, and many islands in the South Sea. The New Hebrides, the Marquesas, the Friendly and the Society Islands, possess this animal, and cultivate it with great care, as it is almost the only domestic animal of which they can boast. The varieties of hog cultivated in Britain, are partly the result of climate and keep in the European variety, and partly the effects of crossing with the Chinese. At the same time, it is only in particular districts that so much attention has been paid to this animal, as to give rise to any accurate distinction of breeds; and nowhere has it received any considerable portion of that care in breeding, which has been so advantageously employed on the other animals of which we have treated. Yet, among none of the varieties of those is there so great a difference as among the breeds of this species, in regard to the meat they return for the consumption of a given quantity of food. Some races can with difficulty be made fat, even at an advanced age, though fed from the trough with abundance of such food as would fatten any other animal; while others contrive to raise a valuable carcase out of materials on which no other creature could subsist.

6540. *The Chinese race, according to Culley, has been subdivided into seven varieties or more; and it would be easy to point out twice the number of as prominent distinctions among the sorts in the third class. But such an affectation of accuracy is as useless as it would be tedious. One general form, approaching to that of other animals kept for their carcase, ought certainly to be preferred; and the size, which is the other distinguishing characteristic, must be chosen with a view to the food provided for their maintenance, and not because it is possible to raise the individuals to a great, and probably, unprofitable weight. The fineness of the bone, and the broad, though also deep, form of the chest, denote in this, as in the other species, a disposition to make fat with a moderate consumption of food; and, while it may be advisable to prefer the larger breeds in those places where bacon and fitches are in most demand, the*

smaller breeds are most esteemed for pickling, and are, beyond all doubt, most profitable to those farmers who allow them little else than the range of the farm-yard, and the offals of the kitchen.

687



6542. *The Hampshire breed* (fig. 688.) are large, longer in the body and neck, but not of so compact a form as the Berkshire; they are mostly of a white color, or spotted, and are well disposed to fatten, coming up to a great weight when properly managed in respect to food. Lawrence says they are generally dark spotted, some black, of a longer and flatter make than those of Berks, ears more pointed, head long and sharp, resembling the Essex.

6543. *The Shropshire breed* is another large breed of hogs, which are found valuable where the keep is in sufficient abundance for their support. They are not so well formed as those of the Berkshire kind, or equal to them in their disposition to fatten, or to be supported on such cheap food. The standard color of this breed is white, or brindled: Shropshire has long bred stores for the supply of the London feeders, and of the Essex farmers, who thus turn their clovers to the most profitable account.

6544. *The Gloucestershire breed* is likewise a larger breed, but inferior to either of the above, being tall and long in shape, and by no means so well formed. The color is in general white. It has two wattles hanging from the throat.

689



6545. *The Herefordshire breed* (fig. 689.) is also a large useful breed, but perhaps without possessing any advantage over those that have been described above.

6546. *The Rudgwick breed* is a large kind of swine, which the author of the *Survey of Middlesex* says, is the largest in the island, met with at the village of that name, on the borders of Sussex and Surrey. They feed to an extraordinary size, and weigh, at two years old, nearly double or triple the usual weight of other sorts of hogs of that age. As large breeds pay the farmers best in many cases, such a breed deserves to be attended to in the system of hog management.

6547. *The large spotted Woburn breed* is a breed introduced by the late Duke of Bedford, being large in size and of various colors. It is a hard, well formed prolific sort, rising quickly to a large weight.

6548. *The Wiltshire breed* is a long-bodied, low hog, hollow about the shoulder, and high on the rump, middling large pointed ears, round bone, light in color.

6549. *Yorkshire breed*. This, in the old breed, was probably the worst large variety we had; extremely long-legged and weak-loined, their constitution not of the soundest; and bad styepigs in the winter season; they were yet quicker feeders than some of the superior breeds. They have been improving some years from the Berkshire cross, but are still inferior to the north-western stock, rendering a less price at market.

6550. *The Northamptonshire breed* was formerly a handsome, light-eared, white, deep-sided pig, with middling bone, and quick of proof: the breeders have since tried the new Leicester.

6551. *The Leicestershire breed* is, in the original stock, large, deep, and flat-sided, light-spotted, with rather handsome head and ear. The Bakewell variety has much merit.

6552. *The Lincolnshire breed* was formerly light-colored and white, like those of Northamptonshire, many of them having curled and woolly coats. They are middle-sized, quick-proving pigs.

6553. *The Norfolk breed* is, a small, short, up-eared porking sort, various in color, white, bluish, striated; generally an inferior kind, which it would be to the interest of that great corn county to improve; they are, however, of a thin-skinned, quick proving kind. But in the vicinity of Lynn, and generally on the Lincoln side of the county, there is a larger spotted variety of very good form and quality, which should be encouraged.

690



6554. *Suffolk breed* (fig. 690.). This is a small delicate white pig, which has for many years had great reputation, and at this time there is not only a strong prejudice in their favor in their own county, but they have many advocates out of it. They are shorter, and more pug-formed than the Norfolks, and by their dish-face, and pendent belly, it may be supposed, that the variety proceeded originally from the white Chinese. Some of the Suffolks are very handsome, and very regularly shaped; their defects are, that they are great consumers in proportion to their small bulk, and that they produce little flesh.

6555. *The Essex breed* are up-eared, with long sharp heads, roach-backed, carcasses flat, long, and generally high upon the leg, bone not large, color white, or black and white, bare of hair, quick feeders, but great consumers, and of an unquiet disposition.

6556. *The small white English breed* is met with in many districts; it is of a white color, thick, compact, and well made in the body; short in the leg; the head and neck well formed, and the ears slouching a little downwards. It is well disposed to fatten, and perfectly hardy. It prevails much in the northern districts.

6557. *Swing-tailed breed*. This is an useful sort of the smaller kind of hogs, hardy in its nature, and of considerable weight in proportion to its size.

6558. There are many other varieties and subvarieties in England which it is unnecessary to notice here. Donaldson remarks, that the Berkshire and Hampshire hogs are the largest; but that it is most probably from the Berkshire stock, that the greatest number of the varieties of the country have sprung.

6559. Of the *Highland breeds*, that of the Hebrides, supposed by Dr. Walker to be the original, is of the smallest size, neither white nor yellow, but of a uniform grey color;

and shaggy, with long hair and bristles; they graze on the hills like sheep; their sole food is herbage and roots, and on these they live the whole year round, without shelter, and without receiving any other sustenance. In autumn, when they are in the best order, their meat is excellent, and without any artificial feeding; but when driven to the low country, they fatten readily, and rise to a considerable bulk. (*Walker's Hebrides*, vol. ii. p. 17.) In the Orkney islands they are commonly of a dark red, or nearly black color, and have long bristles, with a sort of coarse wool beneath them.

6560. *The old Irish breed* are a long legged, thin-sided, lank, haggard, unprofitable sort of swine; but where they have been crossed with the Berkshire, they are considerably improved.

## SECT. II. *Of Breeding and Rearing of Swine.*

6561. In the *breeding* of swine, whatever be the variety, the most perfect and best formed boar and sow should be chosen, and a due regard paid to their age, time of copulation, period of gestation, farrowing, castrating or spaying, and weaning.

6562. *In choosing the boar and sow*, regard must be had to their size, as well as perfection of form. Where food is abundant, or the object of the progeny is the production of bacon and flitches, the larger breeds, as already observed, are to be preferred: but where food is scarce or uncertain, as in the case of the cottager's stock, or rearing for suckled pork, fresh pork, or pickled pork, the smaller breeds, as the Berkshire, are to be preferred. A breeding sow ought to have a large capacious belly, and not to be too much inclined to obesity. To check this tendency, some allow them to breed five times in two years.

6563. *The age of the boar* should not be less than a year, as he will then be at his full growth; nor that of the female less than ten months. They may be used in breeding for three or five years, and then fed off for the shambles.

6564. *The period of gestation* in swine is about four months, so that two litters may be easily produced in a year, five in two years, or ten in four years.

6565. *The best times for copulation* are November and May; because then the progeny are brought forth in mild weather, and when green food is to be had. They should not be allowed to farrow in winter, as young pigs are exceedingly tender, and can with difficulty be preserved in very cold weather; nor at a time when food is scarce, as is generally the case upon corn-farms in summer, if the stock of them is large. When the object is suckled pigs for the shambles, copulation should be so contrived as to produce parturition at all seasons.

6566. *The usual produce* is from about eight to ten or twelve pigs in the large, but more in the smaller breeds, which in general bring the greatest number, and the most early. Twenty swine are estimated to bring at an average seven pigs and a half each for their first litter; but the number varies much, and many young pigs are lost soon after their birth by the unkindness of their dam, and by casualties, to which they are more exposed than most other young animals.

6567. *The pregnant swine* should be separated from the herd some time before she is expected to farrow, carefully watched, and littered with a small quantity of dry short straw. Too much straw is improper, both at the time of farrowing, and for a week or two afterwards, as the pigs are apt to nestle beneath it unperceived by the sow, and are thus in danger of being smothered when she lies down. A breeding sow should be well fed, particularly when nursing; and it is advantageous early to accustom the pigs to feed from a low trough on milk or other liquid food, mixed with meal or bran. Such of the pigs of both sexes as are not to be kept for breeding, are usually castrated or spayed when about a month old, and the whole may be weaned at the end of six or seven weeks.

6568. *The food allowed to growing swine* depends in almost every case upon the circumstances of their owners, for, as already observed, it is a doubtful point whether swine will pay when all their food both in rearing and fattening is to be purchased. The cottager's pig must be contented with the scanty offals of his kitchen and of his dairy, the produce generally of a single cow; towards the end of autumn a few potatoes are added for the purpose of preparing it for the slaughter, and perhaps a little meal is mixed with boiled potatoes for a week or two before. Such pigs, however, often thrive amazingly, make themselves moderately fat, and form a most valuable addition to the winter stores of their owners. In the south-eastern counties of Scotland, the hinds or married ploughmen are commonly allowed to keep a pig each, which they feed in this manner, and from which their families derive much benefit at very little expense. Near woods, acorns, mast, and other seeds, as well as some roots and vermin, afford excellent nourishment. On many corn farms, the chief, and not unfrequently, the only dependence of swine is on the straw-yards. The sweepings of the barn floor, corn left upon the straw, and oats found among the dung of horses, with a share of the turnips given to the cattle in winter, and of the clover in summer, afford ample subsistence to swine, in the proportion, perhaps, of one to every five or six acres under corn, clover, and turnips.

The kitchen and dairy give some assistance to pigs newly weaned, and also to such as are soon to be slaughtered. A great many are killed when about a year old, that have never been fed at any expense that can be estimated. A few pigs, if of a good breed, will always be moderately fat at that age with the run of the straw-yard, and their flesh is of an excellent quality.

6569. *To prevent swine from digging* in the soil, the best method is to cut the two strong tendons of their snouts with a sharp knife, about an inch and a half from the nose. This may be done with little pain, and no prejudice to the animal, when about two or three months old. The common practice of restraining them by rings fixed in the snout is painful and troublesome; they must be replaced as often as they give way, and that happens so frequently, that rings afford but little security against this nuisance.

### SECT. III. *Of Fattening Swine.*

6570. The following system of *rearing and fattening swine on an arable farm* is recommended by a writer in the *Farmer's Magazine*. Upon a tillage farm consisting of three hundred acres, whereof two hundred are kept under the plough, he is of opinion that a considerable sum may be annually gained from keeping swine, were the management arranged in a systematic manner. One main advantage of such a branch of rural economy arises from little or no capital being required to carry it on, while the trouble and outlay attending it scarcely deserve notice. With the addition of one acre of broad clover, and one acre of tares, for the summer and autumn months, and the like extent of ground for turnips and yams during the winter and spring months, this stock of swine may be amply supported.

6571. *Were two breeding sows* kept on a farm of the size mentioned, and their produce reared by the farmer, it may be calculated that forty swine, weighing seven or eight stone each, would be annually fed off, in the months of January and February each year, the time when pork is most in demand. That such a number of swine can be supported and fed upon the offals of a three hundred acre farm, and the other auxiliary articles specified, may be pronounced a certain fact.

6572. *The breeds*, he recommends, are the hardy smaller varieties, but not the Chinese, or any of the pot-bellied sorts; because he has found that such breeds will thrive and grow fat where larger and finer breeds would starve.

6573. *The mode of management* is, that a boar and two good sows of a proper age should constantly be kept, and that one young sow shall annually be reared, in order to supply the others when they pass maturity. He would cast off the oldest sows, *i. e.* feed them when they arrive at three years of age, which, of course, would cause four sows to be in hand at one time. These annually would produce more than the forty pigs which are to be held on; but the remainder might be sold as they are weaned, there being a regular and steady demand in most parts of the country for young pigs. He has for a number of years, kept a stock of swine in the way recommended. They go at large in the court or yard belonging to the farm, and receive a feeding of offal grain in the morning, and of yams or turnips in the evening; and the meat fed in this way has constantly drawn the highest price. They get also the dish-washings of the house, any milk or whey that remains unconsumed, and have the dunghill to roam upon, where perhaps more food is to be gathered, especially if the horses are fed upon unbroken grain, than is commonly imagined. It will readily be figured, that under this mode of management, the latter end of summer and the harvest months is the critical period for carrying on a stock of swine. During these months little threshing goes forward, and horses seldom receive any corn for aliment; hence all that can be consistently attempted is to keep the animals in a growing state, and prepare them for fattening cleverly, when food of a more nutritious quality can be procured. Clover and tares will do this effectually, the last particularly so when in a podded state. Turnips can also be got by the end of September; and it must be recollected, that through the summer months a considerable quantity of milk and whey can be given, upon which swine will be found to thrive heartily. He does not know a more beneficial stock upon a farm than swine, so long as the quantity kept is in proportion to the extent of offals about the premises. The other articles recommended are merely meant to render the consumption of offals more beneficial, to carry on the stock at periods when such offals are scarce. The charge of attendance is very small; indeed, the benefit gained by the dunghill will more than compensate the expenses incurred. To make as much profit from cattle or sheep requires a great advance of money; but in the article of swine hardly any is necessary, while the most part of the articles consumed cannot, in any other way, be converted to such beneficial purposes.

6574. *In fattening for bacon and flitches* the larger breeds are chosen; and in breweries, distilleries, oileries, and dairies, fed on grains, oil-cake, and milk: but where arable farmers keep swine of this description, as is the practice in some of the western counties, the method is to rear chiefly on raw potatoes and Swedish turnips, and to fatten on these roots, boiled or prepared by steam, with a mixture of oat, barley, or bean and pea meal. Their troughs should be often replenished with a small quantity of food at a time, and kept always clean; and their food changed occasionally, and seasoned with salt. If proper care be taken, says a late writer, a feeding pig should not consume more than six Winchester bushels of oats made into meal. It ought to be shelled before it is ground, the same as for family use, but need not be sifted. (*Henderson's Treatise on Swine*, p. 26.)

6575. *In fattening sucking pigs* all that is requisite is to keep the mother well lodged and nourished. Weaned pigs when to be fatted are kept constantly on whey, or skimmed or butter-milk, with frequently an addition of pease or beans, or barley-meal. Such good keeping not only makes them increase rapidly in size, but renders them fit for the butcher at an early age. Swine are sold to the butcher at different ages, and under different names; as pigs when a few weeks old; as porkers at the age of five or six months; and as full grown hogs at from eighteen months to two years old. The young pigs are commonly roasted whole; the porkers are used as fresh or pickled pork;

and the full grown hogs are for the most part converted into ham and bacon. The demand for porkers, which for London in particular is very great, and which continues almost throughout the year, is chiefly supplied from the dairies within reach of that metropolis.

#### SECT. IV. *Of curing Pork and Bacon.*

6576. *The curing or pickling of pork* is carried on to a considerable extent at many of our sea-ports. The carcase is cut in pieces, and packed in casks or kits, made for the purpose, containing from one to two hundred weight. Salt is dissolved in water till the mixture be strong enough to swim an egg; it is then boiled, and, when cold, poured upon the pork: when the end of the cask is fixed in, the article is ready for being sent to market. Henderson, a late writer, has given particular directions for the curing of bacon, founded upon a long course of experience, which, therefore, deserves to be more generally known.

6577. *The curing of bacon* is thus described by Henderson, after much experience. After the carcase has hung all night, lay it upon a strong table, or bench, upon its back; cut off the head close by the ears, and cut the hinder feet so far below the hough as will not disfigure the hams, and leave plenty of room to hang them by; then take a cleaving knife, and, if necessary, a hand mallet, and divide the carcase up the middle of the back bone, laying it in two equal halves: then cut the ham from the side by the second joint of the back bone, which will appear on dividing the carcase; then dress the ham, by paring a little off the flank or skinny part, so as to shape it with a half round point, clearing off any top fat that may appear; the curer will next take off the sharp edge along the back-bone with his knife and mallet, and slice off the first rib next the shoulder, where he will perceive a bloody vein, which he must take out, for if it is left in, that part is apt to spoil. The corners must be squared off where the ham was cut out.

6578. *In killing a number of swine*, what sides you may have dressed the first day, lay upon some flags or boards, piling them up across each other, and giving each pitch a powdering of saltpetre, and then covering it with salt: proceed in the same manner with the hams, by themselves, and do not omit giving them a little saltpetre, as it opens the pores of the flesh to receive the salt, and, besides, gives the ham a pleasant flavor, and makes it more juicy. Let them lie in this state about a week, then turn those on the top undermost, giving them a fresh salting: after lying two or three weeks longer, they may be hung up to dry in some chimney, or smoke house; or, if the curer chooses, he may turn them over again without giving them any more salt, in which state they may lie for a month or two without catching any harm, until he has convenience for drying them. Henderson practised for many years the custom of carting his fitches and hams through the country to farm houses, and used to hang them in their chimnies, and other parts of the house to dry, some seasons, to the amount of five hundred carcases: this plan he soon found was attended with a number of inconveniences, and therefore he invented a smoking house.

6579. *Henderson's smoking house* is about twelve feet square, and the walls about seven feet high: one of these huts require six joists across, one close to each wall, the other four laid asunder, at proper distances. To receive five rows of fitches, they must be laid in the top of the wall; a piece of wood strong enough to bear the weight of one fitch of bacon, must be fixed across the belly end of the fitch, by two strings, as the neck end must hang downwards: the piece of wood must be longer than the fitch is wide, so that each end may rest upon a beam; they may be put so near to each other as not to touch; the width of it will hold twenty-four fitches in a row, and there will be five rows, which will contain one hundred and twenty fitches; as many hams may be hung at the same time above the fitches contrived in the best manner we can. The lower end of the fitches will be within two and a half or three feet of the floor, which must be covered five or six inches thick with saw-dust, and must be kindled at two different sides; it will burn, but not cause any flame to injure the bacon. The door must be kept close, and the hut must have a small hole in the roof, so that part of the smoke may ascend. That lot of bacon and hams will be ready to pack up in a hogshead, to send off in eight or ten days, or a little longer, if required, with very little loss of weight. After the bacon is salted, it may lie in the salt-house as described, until an order is received, then immediately hang it up to dry. Henderson found this smoke-house to be a great saving, not only in the expense and trouble of employing men to cart and hang it through the country, but it did not lose nearly so much weight by this process.

6580. *In the disposal of bacon*, whatever is shipped for the London market, or any other, both bacon and hams, must be packed into a sugar hogshead, or something similar, to hold about ten hundred weight. Bacon can only be cured from the middle of September, until the middle of April. (*Henderson's Treatise on Swine*, p. 39.)

#### SECT V. *Of the Diseases of Swine.*

6581. *Swine are subject to various diseases*, but according to Laurence, they are not easily doctored. They are subject, he says, to pox or measles, blood striking, staggers, quincy, indigestion, catarrh, peripneumonia, and inflammation of the lungs called heavings. When sick, pigs will eat, and they will take medicine in their wash; when they will not eat, there is no help for them. As aperients, cleansers, and alteratives, sulphur, antimony, and madder, are our grand specifics, and they are truly useful. As cordials and tonics, treacle and strong beer, in warm wash, and good pease and pollard. In the measles, sulphur, &c. and, if the patient require it, give cordials now and then; in staggers, bleeding, fresh air, and perhaps nitre; in catarrh, a warm bed, and warm cordial wash, and the same in quincy, or inflammation of the glands in the throat. If external suppuration appear likely, discharge the matter when ripe, and dress with tar and brandy, or balsam. The heavings or unsoundness of the lungs in pigs, like the unsoundness of the liver in lambs, is sometimes found to be hereditary; there is no remedy. This disease in pigs is often the consequence of colds from wet lodging, or of hasty feeding in a poor state; in a certain stage it is highly inflammatory, and without remedy. Uncion with train oil, and the internal use of it, have been sometimes thought beneficial.



## CHAP. VIII.

*Of the Goat, Rabbit, Hare, Dormouse, Deer, and various other Animals, that are or may be subjected to British Agriculture.*

6582. The goat, (*Capra agagrus*, L., fig. 691.) is a native of many mountainous parts of Europe, Africa, Persia, and India; he is domesticated throughout Europe, feeds on branches of shrubs, on lichens, hemlock, &c.; is seldom destitute of horns, of active habits like the deer, treacherous, petulant, roaming, and lascivious; gravid four months and a half, brings from one to two at a birth, and lives ten or twelve years. The female will allow itself to be sucked by the young of various other animals, and a foal which has lost its mother has been seen thus nourished by a goat, which, in order to facilitate the process, was placed on a barrel. The attachment between the nurse and foal appeared strong and natural: in its internal structure, it extremely resembles sheep, but is far superior to them in alertness, sentiment, and intelligence. The goat approaches man without difficulty, is won by kindness, and capable of attachment. The extremely unpleasant odor attending these animals, is supposed to be beneficial, and horses appear so much refreshed by it, that a goat is, on this account, often kept in the stables of the great. It is a singular local peculiarity, that in Angora only, the animals of the *Capra*, *Ovis*, and *Lepus* tribe, have long soft silky hair.

691



6583. The *Angora goat*, a native of Turkey, is chiefly valued for its exquisitely fine hair down, which grows under its coarse hair, and of which the Cashmere shawls are manufactured. The down is obtained by gently combing them. A considerable number of this breed were imported to France from Persia, in 1819, and stationed at St. Omers, with a view to their increase, and the establishment of the shawl manufacture. The kids of this flock are said to be abundantly covered with down and hair, and superior in strength and appearance to indigenous French kids of the same age. It is a common opinion, that the down of this goat degenerates when the animals are removed from the pasturage of Angora; but this is likely in part to arise from the neglect of cleaning and washing them, which at Angora is so assiduously attended to. By a late Report of M. Terneaux to the Paris Agricultural Society, the French Angoras have increased in number, and prosper equally with the native variety.

6584. The *Syrian goat* (fig. 692.) is remarkable for its pendulous ears, and is common in various parts of the East. The animals of this variety are driven in flocks through the Oriental towns every morning and evening, and each housekeeper sees drawn from them, before her door, as much milk as she is in want of.

692



6585. The *Chamois goat*, a native of Switzerland, is a species of antelope, and will be afterwards noticed.

6586. The *goats of Wales* are generally white, and are both stronger and larger than those of other hilly countries. Their flesh is much used by the inhabitants, and often dried and salted, and substituted for bacon. The skins of the kids are much valued for

gloves, and were formerly employed in furniture, when painted with rich colors, of which they are particularly capable, and embellished with ornamental flowers, and works of silver and gold. The goat may be of some advantage in rocky barren countries, where nothing else can get a support for life. They will climb the steepest rocks, and there browse upon briars, heath, and shrubs of various kinds, which other creatures will not taste of. They will feed on grass in pastures; but, as they love browsing on trees much better, great care should be taken to keep them from valuable plantations.

6587. The produce of the goat, from which advantage is chiefly obtained, is the milk, which it yields in large quantities, and which is accounted the best milk of all animals. They mix this and cows' milk together in some parts of the kingdom, and a very valuable cheese is made from it. Besides this, the kids or young goats are very fine food, and the best kinds bring forth two or three at a time, and that twice a year.

6588. Goat's hair is also valuable; it may be sheared as the wool from sheep, and is excellent for making ropes that are to be used in the water, as they will last a great while longer than those made in the common way. A sort of stuff is also made of it in some places.

6589. *The suet of the goat* is also in great esteem, and many of the inhabitants of Caernarvonshire kill them merely for the sake of their fat, which makes candles of a superior quality to the common. Of their horns excellent handles are made for tucks and pen-knives. The skin is peculiarly well adapted for the glove manufactory, especially that of the kid; as it takes a dye better than any other skin. The old skin is also of great use, being preferred to that of the sheep, and the flesh affords a cheap and plentiful provision in the winter months, particularly when the kids are brought to market. The haunches of the goat are frequently salted and dried, and supply all the uses of bacon: this by the Welsh is called *coch yr wden*, or hung venison.

6590. *The kind of goats for keeping to advantage* should be chosen in this manner: the male should have a large body, his hair should be long, and his legs straight and stiff; the neck should be plain and short, the head small and slender, the horns large, the eyes prominent, and the beard long. The female should have a large udder, with large teats, and no horns, or very small ones. Goats should be kept in flocks, that they may not straggle; and they should have good shelter both in summer and in winter, the heat and cold being both prejudicial to them, and coupled in December. They should have no litter in winter, but only a paved floor kept clean. The kids are to be brought up for the table in the same manner as our lambs are.

6591. *The rabbit* (*Lepus cuniculus*, L., fig. 693.), is indigenous in most temperate climates, but not so far to the north as the hare. In a wild state it forms long-winding burrows; keeps its hole by day; feeds morning, evening, and night on vegetables and grain; is the prey of hawks, badgers, polecats, and caught by ferrets; gravid thirty days, brings from four to eight young seven times a year. The varieties common in Britain are the white, black, variegated, and silvery grey. The hare and rabbit are distinguished from each other externally, chiefly by the proportional length of the hind legs to that of the back, and in the ears of the hare being longer, and those of the rabbit shorter than the head. The haunts of rabbits are called warrens; which are most numerous in the sandy soils of Norfolk and Cambridgeshire. They sometimes extend to 2000 or 3000 acres, and many have been hitherto considered to pay better in that state than in any other. Arthur Young, however, has shown in his *Survey of Lincolnshire*, that though a rabbit-warren may afford a high interest on the capital of the occupier, yet the rent it affords to the owner of the soil is less than would ultimately be obtained by planting or breaking up, and laying down with chicory or some other suitable herbage plant. In the meantime, as they continue to exist, and are subjected to a kind of management, we shall submit a short outline of it under the heads of extent, soil and situation, fencing, stocking, breeding, rearing, and produce. Afterwards we shall take a view of the mode of managing rabbits in hutches.

693



6592. *The extent of warrens varies* from 100 to 3000 acres, but a convenient size is considered to be 1500 or 2000 acres. The soil and situation should be dry, sandy, warm, and poor; rich grass or herbage being found to produce a scouring, which sometimes carries off the greater part of the stock. Warrens are generally inclosed with walls either of stone or turf, an essential addition to the latter being a coping of furze, reeds, or stiff straw. Paling is used in some places, but a brook is found insufficient, as the rabbits have been found to swim across.

6593. Warrens are often *stocked* by nature, and all that art has to do in that case is to protect the produce; but in some cases they are formed on ground where rabbits do not exist naturally, or where they exist it is considered desirable to change the breed.

6594. *In stocking a warren*, whether the surface be flat or hilly, artificial burrows are sometimes made, to reconcile the rabbits to the ground, and to preserve them from vermin, until they have time to make their own burrows. These are bored with an auger of a diameter large enough to make a burrow of a sufficient width. In a level warren, these augers may, from time to time, be found useful in forming such holes. They, however, in most cases, are capable of making burrows for themselves. Some warren lands are stocked in the proportion of three couple to an acre; while in others it is in a considerably larger proportion. In Lincolnshire, one buck or male rabbit is said to be sufficient for one hundred does, or females; but this is certainly a much larger proportion, than in most other districts. On the wold warrens of Yorkshire, according to Marshal, one male is considered sufficient for only six or seven females, and the nearer they can be brought to that proportion the greater the stock of young ones that may be expected, it being the nature or economy of the males to destroy their young, especially when the proportional number is too great.

6595. *The varieties employed as stock for warrens* are the common grey and silver grey breeds. The former of which is found to be considerably more hardy and much better for the purposes of food; but the latter has greatly the advantage in the value of the skin. Till lately the common grey rabbit, probably the native wild rabbit of the island, was the only species. At present, the silver-haired rabbit is sought after, and has, within the last few years, been introduced into most warrens. The skin of the grey rabbit is cut; that is, the wool is pared off the pelt, as a material of hats: whereas, that of the silver-haired rabbit is dressed as fur; which, it is said, goes principally to the East Indies. The color is a black ground, thickly interspersed with single white hairs. The skins of this variety sell for about four shillings a dozen more than those of the common sort; a sufficient inducement for propagating it in preference to the grey breed.

6596. *The rabbit begins to breed at an early age*, as at eight, ten, or twelve months, going only about thirty days with young, the young being little more than three weeks old before they appear from the burrows, during which time they are suckled twice in the day by the mother. It is therefore evident, that they may breed three or four times in the course of the year under good keep, as the does take the buck almost immediately after producing their young. In warrens that are inclosed, it is, however, said that they seldom breed more than two or three times in the year.

6597. *The management of a rabbit warren* is a very simple business. Birds and beasts of prey are to be kept off by taking them in traps; dogs and cats kept off, and rats, moles, mice, and other vermin destroyed if abundant or troublesome. Man himself is to be guarded against in some situations. Additional food is to be supplied in the winter season, when the weather is severe, such as fine green hay, raintfoin, clover

turnips, and others of the same sort, which must be distributed over the warrens. It is supposed that turnips answer the best in deep snow, as the rabbits can discover them by the scent. This sort of food is given in the quantity of two or three large cartfuls to a thousand couple per day, and one load of hay in the same time during a storm. It is likewise sometimes the practice to distribute billets of new cut ash-boughs, gorse or whins, and other similar woods in the warrens, the bark and other parts of which is eaten, by which the proportion of hay is lessened in a considerable degree. In great snows it is necessary to clear it away from the ditches or fences to prevent the rabbits from getting over them.

6598. This sort of stock is *mostly taken by nets or traps*, set in the form of a fold between the places where they run, and those where they feed, the rabbits being hunted into them as they return from feeding. Sometimes they are taken by ferrets and terriers. The wold warreners, Marshal says, have three ways of catching their rabbits: with fold nets; with spring nets; and with types, a species of trap. The fold nets are set about midnight, between the burrows and the feeding grounds; the rabbits being driven in with dogs, and kept inclosed in the fold, until morning. But the spring net, when used, is, he believes, generally laid round a hay stack, or other place, where rabbits collect in numbers. It is added that the trap is a more modern invention. It consists of a large pit or cistern, formed within the ground, and covered with a floor: or with one large falling door, having a small trap-door towards its centre, into which the rabbits are led by a narrow mouth. This trap on its first introduction, was set mostly by a hay-stack; hay being, at that time, the chief winter food of rabbits; or on the outside of the warren wall, where rabbits were observed to scratch much, in order to make their escape. Since the cultivation of turnips, as a winter food for this species of stock, has become a practice, the situation of the trap has, he says, been changed. Turnips being cultivated in an enclosure within the warren, a trap is placed within the wall of this enclosure. For a night or two, the mouth is left open, and the trap kept covered, (with a board or triangular rail), in order to give the rabbits leave to retreat.

6599. *The annual produce per acre*, is mostly estimated at from three or four, to eight or ten couple, yielding a profit of from eight to ten, or even fifteen shillings, where they are conducted under a good system of management. The produce is the largest on new lands; however, much of the profit must always depend on situation, so as to be near good markets. These animals are in what is termed season from the end of October to the beginning of January, in which period the best skins are produced, of course a large proportion of them is killed in this short time. The farmer often sustains great loss in what by the purchasers are called half skins, quarter skins and racks, sixteen of which are only considered as a whole skin. The rabbits are disposed of by the hundred, six score couple being considered as an hundred.

6600. *The breeding and rearing of tame rabbits* is carried on in hutches or stores of boxes placed in sheds or apartments of any kind secure from vermin. We shall give a view of the practice as to rabbitry and furniture, varieties, breeding, feeding, and produce.

6601. *The rabbit house*, should be particularly dry and well ventilated, as these quadrupeds are very subject to the rot, and to liver complaints like sheep.

6602. *The huts or hutches*, (fig. 694.) are boxes or chests eighteen inches or more high, and from two and a half to three feet wide, generally divided in two (a and b), and the rooms thus formed communicating by a sliding door, the use of which is to confine the rabbits in the inner division (a), whilst the outer, which has a wire door, (fig. 695.) is cleaned. Generally these hutches



694

695

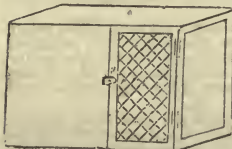

are placed in rows above each other against one side of the rabbit-house, and sometimes they are placed in the open air, against a wall within a wired or netted enclosure. Sometimes they are ranged along the floor; but the neatest mode is to place them on brackets round the room, or on stands about three feet high on the floor. In both these cases it is to be understood that they are not allowed to run about the rabbit room, the use of which is solely to enclose and protect them in an atmosphere of moderate temperature, and to contain a birr with corn, a truss of clover, hay, and any such food as sheep will live and thrive upon. The utensil for feeding rabbits so hutched is simply a trough (c), which may be formed of pewter, very hard wood, earthenware, or cast iron, as rabbits are very apt to gnaw them; and it should

be divided on the surface cross ways every four or six inches to prevent them from scratching and throwing out their corn. Some add a small rack for their clover, but that will not be lost if given on the floor in small quantities.

6603. There are numerous *varieties of tame rabbits*; but the broad-chested and short-legged are the most hardy, and fatten most expeditiously. There is a large variety of the hare color, which has high colored and high flavored flesh, more savoury than that of the common rabbit; they make a good dish cooked like the hare, which at six or eight months old they nearly equal in size. The large white, and yellow and white species, have whiter and more delicate flesh, and, cooked in the same way, will rival the turkey. The Turkish or French rabbit is esteemed by some, but differs little from the common variety. All these and other varieties are to be had from the London dealers and poultrymen.

6604. *Breeding*. The doe will breed at the age of six months; and her period of gestation is thirty or thirty-one days. It should be premised, that the buck and doe are by no means to be left together; but their union having been successful, the buck must be immediately withdrawn, and the doe tried again in three days: in fact, with rabbits, this business is conducted on the same principle as in the stud. Like chickens, the best breeding rabbits are those kindled in March. Some days before parturition, or kindling, hay is to be given to the doe, to assist in making her bed, with the fue, which nature has instructed her to tear from her body for that purpose. She will be at this period seen sitting upon her haunches, and tearing off the fue, and the hay being presented to her, she will with her teeth reduce and shatter it to her purpose. Biting down of the litter or bed, is the first sign of pregnancy. The number produced, generally between five and ten; and it is most advantageous always to destroy the weak or sickly ones, as soon as their defects can be perceived, because five healthy and well-grown rabbits are worth more than double the number of an opposite description, and the doe will be far less exhausted. She will admit the buck again with profit at the end of six weeks, when the young may be separated from her and weaned. Or the young may be suckled two months, the doe taken back at the end of five weeks, so that the former litter will leave her about a week before her next parturition. A notion was formerly prevalent, of the necessity for giving the buck immediately after the doe had brought forth, lest she should pine, and that no time might be lost; and if it were intended that no time might be lost in destroying the doe, such indeed, would be the most successful method. Great care should be taken that the doe, during her gestation, be not approached by the buck, or indeed by any other rabbit; as, from being harassed about, she will almost certainly cast her young. One doe in a thousand may devour her young; the sign

that she ought to be otherwise disposed of. Some does admit the buck with difficulty, although often apparently in season; such should be immediately fattened off, since it can never be worth while to keep any individual for breeding of a stock to be produced in such multitudes, against which there lies an objection. Should the doe be weak on her bringing forth, from cold, cough, or other causes, she will drink beer-cuddle, as well as any other lady; or warm fresh grains will comfort her; a salt-mash; scalded fine pollard, or barley-meal, in which may be mixed a small quantity of cordial horse-ball. With due attention to keeping them warm and comfortable, and guarding against every sudden impression from cold, and more particularly moist air, and with the aid of the best and most nourishing food, rabbits may be bred throughout the winter, with nearly equal success as in the summer season. But, in truth, their produce is so multitudinous, that one might well be satisfied with four or five litters, during the best part of the year, giving the doe a winter fallow.

6605. *Feeding.* According to Mowbray, it is better to feed three times than twice a day. The art of feeding rabbits with safety and advantage, is, always to give the upper hand to dry and substantial food. Their nature is congenial with that of sheep, and the same kind of food, with little variation, agrees with both. All weeds, and the refuse of vegetation, should be banished from rabbit feeding. Such articles are too washy and diuretic, and can never be worth attention, whilst the more solid and nutritious productions of the field may be obtained in such plenty, and will return so much greater profit. Rabbits may, indeed, be kept, and even fattened upon roots, good green meat, and hay; but they will pay for corn; and this may be taken as a general rule: rabbits which have as much corn as they will eat, can never take any harm from being indulged with almost an equal portion of good substantial vegetables. However, the test of health is, that their dung be not too moist. Many, or most, of the town feeders never allow any greens at all; the reason, I suppose, because they feed almost entirely on grains. The corn proper for rabbits, is oats, peas, wheat, pollard, and some give buck-wheat. The greens and roots, the same as our cattle crops, namely carrots, Jerusalem artichokes, and if potatoes, baked or steamed. Lucerne, cabbage leaves, clover, tares, furze. Mowbray has had them hoven, from eating rape; and not improbably, field-beet might have a similar effect. The best dried herbage is clover and meadow hay, and pea and bean straw.

6606. *Rabbits are generally sold from the teat*, but there is also a demand for those of larger size, which may be fattened upon corn and hay, with an allowance of the best vegetables. The better the food, the greater weight, better quality, and more profit, which is generally the case in the feeding of all animals. Some fatten with grains and pollard. Mowbray tried wheat, and potatoe oats, comparatively; but could find no difference in the goodness of their flesh. The rabbit's flesh being dry, the allowance of succulent greens may tend to render it more juicy; and probably the old complaint of the dryness of the flesh in Devon beef, entirely fed with hay, might be remedied in the same way. Rabbits are in perfection for feeding at the fourth or sixth month; beyond which period, their flesh becomes more dry and somewhat hard. It requires three months, or nearly so, to make a rabbit thoroughly fat and ripe; half the time will make them eatable, but by no means equal in the quality of the flesh: they may yet be over fattened, as appears by specimens exhibited a few years since at Lord Somerville's show, which were loaded with fat, without and within, like the best feeding sheep.

6607. *The flesh of the rabbit* is esteemed equally digestible as that of fowls, and equally proper for the table of the invalid.

6608. *Castrated rabbits* might be fattened, no doubt, to the weight of upwards of ten pounds, at six or seven months old. It is said to be successfully practised in Sussex, near Chichester, where on the average, not one in three hundred is lost by the operation, which is performed at five or six weeks old. With respect to the quantity of corn consumed in fattening; a young buck, which weighed three pounds, fit for the spit, was put up in good case in August, and was only one month in feeding, consuming not quite four quarts of oats, with hay, cabbage, lucerne, and chicory; the skin, silver and black, worth four pence.

6609. *In slaughtering full-grown rabbits*, after the usual stroke upon the neck, the throat should be perforated upwards towards the jaws with a small pointed knife, in order that the blood may be evacuated, which would otherwise settle in the head and neck. It is an abomination to kill poultry by the slow and torturing method of bleeding to death, hung up by the heels, the veins of the mouth being cut; but still more so the rabbit, which in that situation, utters horrible screams. The entrails of the rabbit, whilst fresh, are said to be good food for fish, being thrown into ponds.

6610. *The rabbit is a caressing animal*, and equally fond, with the cat, of the head being stroked; at the same time it is not destitute of courage. A whimsical lady admitted a buck rabbit into her house, when he became her companion for upwards of a twelvemonth. He soon intimidated the largest cats so much, by chasing them round the room, and darting upon them, and tearing off their hair by mouthfuls, that they very seldom dared to approach. He slept in the lap by choice, or upon a chair, or the hearth rug, and was as full of mischief and tricks as a monkey. He destroyed all the rush-bottomed chairs within his reach, and would refuse nothing to eat or drink, which was eaten or drank by any other member of the family.

6611. *Diseases.* No live stock is less liable to disease than the rabbit, with regular and careful attention, such as has been pointed out, so that any sudden and accidental disorder is best and most cheaply remedied by a stroke behind the ears. But want of care must be remedied, if at all, by an opposite conduct, and improper food exchanged for its contrary. Thus, if rabbits become pot bellied in the coramon phrase, from being fed on loose vegetable trash, they must be cured by good hard hay and corn, ground malt or pease, or any substantial or absorbent food. Their common liver complaints are incurable, and when such are put up to fatten, there is a certain criterion to be observed. They will not bear to be pushed beyond a moderate degree of fatness, and should be taken in time, as they are liable to drop off suddenly. The dropsy and rot must be prevented, as they are generally incurable; nor is a rabbit worth the time and pains of a probable cure.

6612. *The hare, (Lepus timidus, L., fig. 696.)* if taken young may be tamed and domesticated, and has occasionally been nursed by a cat. Sonnini the naturalist, and Cowper the poet, had hares in a complete state of domestication. As the fur of this animal is of greater value for hat making than that of the rabbit, it would be a very desirable circumstance if it could be substituted for that animal in warrens. Its flesh would certainly be deemed preferable, and in general it is a large animal. It lives on the same sort of food as the rabbit, produces generally three young ones at a time, and breeds at least three times in a year. It is not improbable that in some dry situations where the soil is dry and poor, a hare warren or pack might be found to answer; the price in the metropolis being never less than ten times that of rabbits.



6613. There is a *hare warren* near Banstead Downs: it contains about three acres of ground; 200 brace are usually kept in it; they are fed in the summer on clover, rape, &c.; and in the winter, on hay. The warren is surrounded by a brick wall about ten feet high, with openings at regular distances, within which are wire gratings on hinges: these give way to the hares, when they enter the warren; and they are so constructed, that they immediately close after them, and so prevents their escape.

6614. The *Guinea pig*, or *restless Cavy*, (*Cavia Cobaya*, L. fig. 697.) is a native of Brazil, but domesticated in Europe, and treated and used like the tame rabbit. In Italy, the flesh is considered a delicacy, and the skins are nearly as valuable as those of rabbits. The Guinea pig is one of the most prolific of animals, and Buffon calculates that in twelve months only, 1000 might be produced from a single pair, as the female has been known to bring forth young when two months old only; the time of gestation is only three weeks; and she will produce at least every two months. The young are six or seven months before they arrive at their maturity of growth, but within the short period of twelve hours from their birth are nearly as alert and active as those fully grown, and therefore require parental assiduity only for a little time. Vegetables form their food, and on a great variety of these they will flourish and fatten. They drink but little, appear after eating to ruminate, and are extremely apt to be affected by cold. They are uncommonly clean in their habits, and are often to be seen smoothing and cleansing their fur with particular attention and perseverance.

697



6615. The *fat dormouse* (*Myoxus glis*, L.) is a native of the woods of Germany and Russia; and has a good deal of the habits of the squirrel. It feeds on fruits, lays up a winter store, forms its nest in hollow trees, sleeps by day, and grows very fat in autumn. It was cultivated by the Romans, and highly prized by them as food. The body is six inches long.

6616. Of the *deer* (*Cervus*, L.) there are three species in cultivation in this country: the stag, roe, and fallow deer. The latter are now almost exclusively cultivated in parks, as articles of luxury, and, it is conceived, might answer to a small extent in farming.

6617. The *stag* (*C. Elephus*, L., fig. 698 a) is found in nearly all the temperate

698



climates of Europe and Asia. It is also found in North America, but attains its largest size in Siberia. From the branchiness of its antlers, the elegance of its form and movements, and the strength of its limbs, it deservedly attracts particular admiration, and may be regarded as a principal embellishment of the forest. The stag is remarkable for a fine eye, and an acute sense of smelling. His ear also is exquisitely sensible, and musical sounds appear to possess over him the power of exciting complacency, if not rapture. His enemies not unfrequently employ the shepherd's pipe to decoy him to his destruction; and Playford, in his *Introduction to Music*, states that he once met a herd of twenty stags near Royston, which readily followed the tones of a violin and bagpipe, played by their conductors, but stopped whenever the music was suspended. Their whole progress from Yorkshire to Hampton Court was attended, and it was supposed extremely facilitated, by these sounds. The stag is simple and unsuspecting, and employs no arts to avoid detection or pursuit, until after having received considerable molestation. His food consists in winter of moss and bark; in spring of the catkins of willow and hazel, and the flowers and buds of cornel; in summer, of the grain of rye, and the tender shoots of the alder; in autumn, of the leaves of brambles, and the flowers of heath and broom. He eats with slowness, and ruminates with some considerable effort, in consequence of the distance between the first stomach and the mouth. In March,

generally, he sheds his antlers, which are not completely renewed till August. He will live to between thirty and forty years of age, and was formerly, amidst the other vulgar errors of antiquity, supposed capable of attaining most extraordinary duration. The stag is supposed to have been introduced from France into England, where he has latterly been made to give way to the fallow deer, an animal more gentle in its manners, and more valuable as food. In some parts of Scotland he is yet to be found in his original wild state. A stag of five years old is, in hunting, termed a hart; the female, hinds; and the young, fawns.

6618. *The roe* (*C. capreolus*, L., fig. 698 b) is the smallest of the deer tribes which are natives of Europe; it is generally of a reddish brown color; graceful, sprightly, and courageous, particularly cleanly, and delighting in dry and mountainous situations: it leaves a strong scent behind it, but possesses such arts of defence, that by various doublings and intermixtures of past with present emanations from its body, it frequently baffles the most experienced dogs, and remains in a state of security, while the full pack passes almost close by its retreat, distinguishing it neither by sight nor smell: it differs from the stag in the constancy of its attachment, and the parents and their young constitute a family, never associating with strangers: two fawns are generally produced by the female at a birth, one of each sex, which, living together, form a mutual and invincible attachment. When a new family is to be nursed, the former is driven off to provide for itself, but returns again after a certain interval to the mother, whose former affection is restored: a final separation speedily takes place, however, soon after this return, between the fawns of the season preceding the last and their dam; and the former remove to a distance, constituting a distinct establishment, and rearing an offspring of their own. When the female is about to bring forth, she secludes herself in some remote recess of the forest, from which she returns at the end of about ten days, with her fawns, just able slowly and weakly to follow her steps: in cases of danger she hides them in a place deemed by her most secure from the enemy, and attracts the attention of the latter from them to herself; happy, by her own perils or even destruction, to effect the security of her offspring. In winter, these animals feed on brambles, broom, heath, and catkins; and in spring they eat the young wood and leaves of almost every species of tree, and are said to be so affected, as it were with intoxication, by the fermentation of this food in their stomachs, that they will approach men and other enemies (whom they generally shun with great care), without apprehension or suspicion. The flesh of these animals is excellent, though after two years of age that of the males is ill-flavored and tough. The roe exists now in no part of Ireland, and, in Great Britain, only in a few districts of the Highlands.

6619. *The fallow deer* (*C. dama*, L., fig. 698 c) is in general much smaller than the stag; but in Spain is nearly equally large: in France and Germany it is rarely to be found, and it has never been known to have existed in America: it has the elegance of the stag, connected with a much more tractable disposition: it sheds its antlers, which, as in the stag species, are peculiar to the male, every year; is stated to live to the age of twenty years, and arrives at its maturity in three; it is by no means fastidious in its food.

6620. *Deer husbandry*. The author of the *Agricultural Survey of the County of Hertford*, observes, that "the Earl of Clarendon, justly considering that there is no more impropriety in converting one animal to profit than another, makes deer an object of husbandry. As soon as the rutting season is over, or usually about the 10th of November, his lordship selects from the herd, the weak ones, some of which would probably die in the winter, and keeps them in a small yard that has a shed on one side, and a net over the whole against pigeons, &c.; the spot very warm, and well sheltered. Their antlers are immediately sawn off, the place is well littered, and they are fed at a very small expense on pea-straw, hay, &c. warmth making up for the want of better food. At times, during the winter, they have clover-hay cut into chaff, and if they do not eat it well, a little salt is added. They have always plenty of water, and are kept perfectly clean: much attention should, he says, be paid by the keeper to make himself familiar with them, that he may enter the place without disturbing them. The first week in March he gives them oil-cake, about half a cake each a-day, with chaff, which fattens them so quickly, that all are gone in May. Before killing, they have some green meat given, to take away any ill flavor from the cake, supposing such to be the effect of the food, for it is certain that the venison is exceedingly good. As to weight, a haunch usually weighs about 24 pounds; a brace is sold for 15 guineas: the skin, worth 2l. 2s. is the keeper's perquisite; so that the value of a brace amounts to 17l. 17s. exclusive of some trifling articles. The purchaser sends for them." It is added, that his lordship usually fattens nine brace: his whole winter-stock rises to 350 head, in a park of 250 acres, but much of it is thickly covered with timber; 30 sheep and ten cows also feed in it. The park consumption of hay amounts to 32 loads, being reduced to that quantity by the use of much browse; all ash, elm, and Scotch pine, being brought for that purpose before faggotting, which not only saves hay, but improves the flavor of the venison.

6621. By *castrating the males of deer* when newly dropped, which is not in the least dangerous, it affords the means of having good venison until Christmas, without any other sort of food than the common grass; they also fatten more quickly; the operation must, however, be performed while they are quite young. (*Devonshire Report*.)

6622. *The moose deer, or elk* (*Cervus alces*, L.), is indigenous in Europe, America, and Asia, as far as Japan, and was formerly wild in this country though now extinct. It is of the size of a horse; gentle, except when teased by the gad-fly; feeds on twigs, and branches of trees, and marsh plants; goes on its hoofs with a shambling gait at the rate of

fifty miles a day; has a skin so hard as almost to resist a musket ball, but flesh tender and good. This animal might be introduced as an inhabitant of parks, where it would add to the variety of animated woody scenery and of venison.

6623. The rein deer (*Cervus tarandus*, L., fig. 699.) is an inhabitant of the alpine mountains of America, Europe, and Asia, and is too remarkable an animal, and too well known, to require a particular description or account of his habits. The tame variety have been introduced more than once in this country by the Hon. Daines Barrington, Bullock, and others, but cannot be kept in parks on account of the want of their particular lichen. As this lichen abounds on several mountains in Yorkshire, and on many in Scotland and Ireland, some patriotic and curious noblemen might attempt its cultivation. The milk and cream, as Dr. Clarke states, are most

699



excellent, and also the flesh, and even as an article of profit, the sale of the animals as breeding stock would pay for a time. Lichen hay might no doubt be imported at an easy rate from the gulf of Bothnia; and the animal by degrees in the course of a few generations might be habituated to grass or the spray of trees.

6624. The antelope (*Antelope*, L.) is a beautiful and numerous genus of animals, partaking of the nature of the goat and deer. Two species, the *A. saiga*, or scythoon, and the *A. rupicapra* or chamois, are natives of Europe, but the rest of hot climates. Antelopes, Pennant observes, are animals generally of a most elegant and active make; of a restless and timid disposition; extremely watchful, of great vivacity, remarkably swift and agile, and most of their boundings so light and elastic, as to strike the spectator with astonishment. What is very singular, they will stop in the midst of their course, gaze for a moment at their pursuers, and then resume their flight. As the chase of these animals is a favorite amusement with the eastern nations, from that may be collected proofs of their rapid speed. One of the highest compliments that can be paid to female beauty in the eastern regions, is *Aine el Cazel*, 'you have the eyes of an antelope.' Some species of antelopes form herds of two or three thousand, while others keep in troops of five or six. They generally reside in hilly countries, though some inhabit plains: they often browse like the goat, and feed on the tender shoots of trees, which gives their flesh an excellent flavor.

6625. The common antelope (*A. cervicapra*, L.) abounds in Barbary, and in all the northern parts of Africa. It is somewhat less than the fallow deer: its horns are about sixteen inches long, surrounded with prominent rings almost to the top, where they are twelve inches distant from point to point. The horns are remarkable for a beautiful double flexion, which gives them the appearance of the lyre of the ancients. The color of the hair on the back is brown, mixed with red; the belly and inside of the thighs white; and the tail short.

6626. The chamois antelope (*A. rupicapra*, fig. 700 a) was formerly considered as belonging to the genus capra, and is generally called the chamois goat. It is found on the mountains of Switzerland, where it is very shy, and hunted both for its flesh and skin. (341.)

700



6627. The Scythian antelope, (*A. saiga*, L.) bears a good deal of resemblance to the common goat, and it is fully as easily tamed. They are found in immense flocks on the banks of Boristhenes and other parts of Russia, where they are valued both for the flesh and their skin, which is equal to that of the chamois for gloves.

6628. The nilgau, or white-footed antelope, (*A. pictor*, L., fig. 700 b) is a large and beautiful species, known only within the space of a few years past. Its height is four feet one inch to the top of the shoulders; its length, from the bottom of the neck to the base of the tail, four feet; and the color a fine dark grey. The nilgau has of late years been often imported into Europe, and has bred in England. In confinement, it is generally pretty gentle, but is sometimes seized by fits of sudden caprice, when it will attack with

great violence the object of its displeasure. The nilgau is said to go with young about nine months, and to produce sometimes two at a birth: the young is of the color of a fawn.

6629. The above and various other species of antelopes might probably be acclimated and introduced in parks as objects of luxury. The cultivator who first succeeded in breeding them would find an ample demand at his own price if they happened to come in vogue.

6630. The camel (*Camelus*, L.), is a genus of which there are several species, three of which, the dromedary, or Arabian camel (fig. 701.), the Bachian, and the lama or Peruvian sheep, might certainly be partially acclimated in England, as the first is completely so in Italy. (297.) They live upon a very little of the coarsest herbage; might have a warm house well littered to retire to in winter, or in cold nights, and would form a singular ornament to park scenery. Besides their hair and skin are valuable, and they might be sold perhaps to romantic travellers, or cavalier quacks.

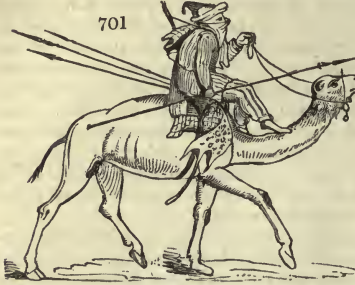

6631. The lama (*Camelus glama*, L., fig. 702.) is the camel of South America; and appears to hold a middle place between the sheep, deer, and camel. Before the entry of the beasts of burden known to the South

trance of the Spaniards, lamas were the Americans. Like camels, they travel slowly, but are persevering, tractable, and very sure-footed. Since the introduction of mules, they are much less cultivated; but before they were depended on to carry the ores dug out of the rich mines of Potosi. The lama is furnished as the camel with ability to abstain from water, by keeping a quantity in its second stomach. Like the camel, its feet also divide, and spread; but by no means equal to those of the camel. It is also furnished with a singular protuberance or spur behind, which enables it the better to lay hold on the ground. The tame are of various colors, and some of them are smooth and others rough. The height of the lama is about four feet, and its length from the neck to the tail about six feet. It has a capacity of throwing out the saliva to a considerable distance, but which is not possessed of any acrid quality.



6632. The *camelopard* (*Camelopardalis giraffa*, L.), a most singular and noble animal, seventeen feet high, and as tame and gentle as the camel, might also be naturalized. It lives on the green spray of trees, and grass, and frequents forests.

6633. The *elephant*, *rhinoceros*, *musk ox*, and a variety of other exotic domestics, might be so far acclimated as to live in Britain as they do in the *Jardin des plantes* at Paris, viz., with an enclosure for each sort, and a lodge or house for protection in winter or during inclement weather. Were as much attention paid to introducing alive, and acclimating foreign animals, as there is directed to the same branch of culture in plants, we should soon possess a rich Fauna, and the public taste may in time take this direction.

6634. In *acclimating* the more tender animals, it might be desirable to rear a few generations, first in the south of Italy or in Spain, next in France and afterwards in the south of England. But the camel, musk ox, zebra, quagga, and antelope might be had at once from the acclimated stock in Italy.

6635. The *dog* (*Canis familiaris*), is an animal of universal utility and interest. From the earliest ages he has been the companion and assistant of the herdsman; and without his aid the flocks must have been confined to narrow limits, and consequently their propagation would have been greatly lessened. But hardy and bold, he watched by night, and toiled by day; securing his charge from the human thief, or the ravenous predatory beasts in the one, and collecting and organising their march during the other. Without the dog, sheep-farmers of the present day would be often at a loss to restrain the wanderings of their flocks; nor is he less useful in guarding the yard by nightly watchings.



6636. *The genus canis* includes other animals, as the wolf, the fox, the jackal, and the hyæna: and many naturalists have supposed our subject, the dog, to be only a mixed animal, originating from the union of some of these. Such is the opinion of Guldenstadt, Pallas, and Pennant; while the higher names of Blumenbach and Cuvier, are ranged among those who assign him a distinct and specific origin. Blaine, who has long successfully advocated the cause of the dog, has bestowed much research on this point; and appears clearly to have traced the dog through his numerous varieties, to a specific origin; but whether originating from a specific or a spurious source, the dog has descended down into such innumerable varieties, that a detail of the forms and properties of them, as they appear among us only, would be utterly impossible. The wants, as well as the luxuries of man, have, however, laid hold on some of these varieties, and have fixed them into permanencies, by confining the sexual intercourse to their congeners alone, and of this number there are no less than forty. It would be unnecessary to draw the character of the dog as stated at length by Linnæus and others: the outlines are the same in all.

6637. *The shepherd's dog*, in an agricultural point of view, ranks foremost among the numerous varieties: indeed, the fanciful Buffon makes him the father of the whole race of dogs. But did no other difficulty arise, an insuperable one would be found in the opposite characters which different breeds of this dog possess. Few animals can be more unlike than the small sheep-dog of the Highlands of Scotland, and the monstrous drovers' dog of Smithfield.

703



6638. *The English sheep-dog* (fig. 703.), is usually larger than the northern, is longer on the legs, and has been so long accustomed to have the tail taken off nearly close to the rump, that in some instances the custom has operated on nature; and these dogs are sometimes pupped tailless. The shepherd's dog is not, however, usually bred so large as the real cattle or drover's dog; but is yet sufficiently strong and fierce. Their color is in general black and white, with half pricked ears: they are extremely docile and intelligent, and seem almost to understand the looks of the shepherd. Some of them are smooth-coated; but by far the greater number are rough, and have their hair crisped, which enables them better to bear the effects of continued

exposure. The dog very erroneously described by minor naturalists as the *cur dog*, is nothing more than the shepherd's dog, confined principally to the operations of the farm; and often bred rather taller, and either smooth or rough, according to circumstances. The very term *cur* destroys all individuality of breed; it being applied to characterise any dog of spurious origin: neither in these farm-yard dogs is any characteristic difference whatever observed in forms, qualities, or uses. When the sheep-dog is generally employed in watching the farm-yard, he becomes more fierce and active; he accommodates his powers to the particular circumstances required of him; he knows every field, and every beast, and keeps the whole in subjection. His bite is keen, and principally directed at the heels of cattle, by which he keeps himself safe, and does not injure them.

6639. *The sheep-dogs of Scotland* are varied in form and size (figs. 704. and 705.), but are all of them usually smaller than those in use in England: they are, nevertheless, without competitors in sagacity and excellence. Their general characters are, ears

704



705



partially upright, head rather pointed, shaggy coat, and a remarkable villocity, or fulness of tail beneath. Immense flocks of sheep may be seen ranging the wilds, without other control save the shepherd and his dog, which receives his commands, executes them, and then waits for further instructions: or, he often acts with great judgment and promptitude from the impulses of his own sagacity, in which, perhaps,

these dogs never shine more than in their readiness to distinguish the individuals of their own flocks, and their adroitness in keeping out intruders. In driving a number of sheep to any distance, a well-trained dog never fails to confine the sheep to the road: he watches every avenue that leads from it, where he takes his stand, threatening every delinquent; and pursues the stragglers, forcing them into the ranks without doing them any injury. If the herdsman be at any time absent, he rests satisfied, knowing his dog will not abandon his charge, but will keep them together; and the moment he returns, the sagacious animal gives up his trust, or conducts them to his master according to the word or signal given.

6640. *The mastiff or guard* (fig. 706.), is a noble animal derived from the Dane; but by selection and cultivation is rendered thicker and heavier, though less tall than his original. The powers of this dog are immense; and as a guard he is unrivalled: having the ferocity of a tiger to a stranger, with the gentleness of a lamb towards those he knows. His sagacity in detecting the attempts of robbers, and his fidelity in resisting all their bribes, are such, that it is to be lamented his breed has given place to that of the Newfoundland dog, whose qualities as a guard are certainly not equal to his. The mastiff is characterised by small pendulous ears, smooth coat, color various, often reddish or brindled. The lips are pendulous, jaws of immense strength, but seldom under-hung; and his general form is symmetrical for strength.

706



6641. *The bull-dog* can no otherwise be considered as connected with agriculture, than as he is too often used in the disgraceful and inhuman sport of bull-baiting: and however we may admire his invincible fortitude, and his contempt of pain and danger, we must

allow him to be the most useless among the dog species. In his attack on cattle he always aims at the front, and generally fastens on the upper lip, where he will hang in spite of every effort of the animal to disengage himself.

6642. *The terrier* (fig. 707.) is a dog of very great utility, and of very varied form and size. His qualities have gained him the greatest care in selection, training, and continuing the numerous distinct breeds we witness. The principal varieties may be reduced into the rough and the smooth breeds. The *rough breed* is originally derived from Scotland, where it is still preserved in a few families in its original purity. These specimens are seldom large, but are exceedingly rough and shaggy in their hair, which is much crisped and brindled. The rough breed in England has become larger, and is very often seen white. When mixed with the bull breed, this terrier becomes fierce, much inclined to combat, and forms an excellent guard. The *smooth breed* produces endless varieties; the principal of which is an elegant black animal with tan markings. A second variety is of varied colors, smaller, thicker, and longer; and is used for earthing foxes, badger-baiting, and vermin killing in general. For rabbit hunting, a wry-legged breed is in considerable request. Although particular varieties are often appropriated to particular purposes, yet all have a common property, which renders them invaluable to the agriculturist; which is their determined hostility to those animals termed vermin, as foxes, otters, badgers, polecats; with rats and mice. To attack the former, they are bred strong, and have a portion of the bull breed in them: for the latter their hardihood, activity, and keenness of gripe, are particularly studied: in which the middle-sized breeds are frequently found to excel.

707



6643. The *pointer, setter, and spaniel*, (fig. 708.), it might seem at the first view unnecessary to introduce to the notice of the agriculturist; but a little examination of the subject will show that they



may be made an object of considerable importance to the farmer. Few dogs command such prices as sporting dogs; and few persons have such opportunities of rearing them so cheaply, or so well, as farmers. Many farmers shoot game; most of them do it more or less: and it would be very easy to make two brace of pointers or setters, with one or two brace of spaniels, pay a considerable part of the rent of the farm, without other expense than skimmed milk and potatoes, or occasionally a little barley meal. We will suppose that a farm has on it three pointer bitches, and one pointer dog, all of acknowledged excellence, and two out of the three bitches may be expected to go to heat early, and to produce progeny between the seasons of shooting, when they are wanted: from these, four brace of puppies may be saved, and by continually following the servants and their master, they will become so handy, that their breaking will be effected daily, and without any other trouble than what occurs in restraining them when a little wild. If their breed is very good, their stopping and barking will commence towards the end of the first season, and during the periods between this and the next autumn they may be steadied and practised in fetching their game, &c., as directed in good sporting works. At the commencement of the following season, if they have been well attended to, although only fifteen months old, the whole may be sold to the London or country dealers, to average six or seven guineas each: or if sold privately, they will fetch from eight to twelve and fifteen guineas each: out of which, perhaps not more than half a guinea can fairly be deducted for keep, &c. The trouble occasioned to the master will be trifling, because connected with a pleasing employ to him as a sportsman, and who will thus have his own sporters for nothing.

6644. *Setters*, as more valuable, will fetch a higher price: but they do not always command so ready a sale, and are more troublesome to break.

6645. *Spaniels* are commonly thought, but most erroneously, almost to break themselves. A really well broke spaniel, however, is so rare, that instead of being worth two or three guineas, which is the usual price, it will fetch from five to ten pounds. It would be even less difficult to the farmer to rear spaniels than pointers; and by following him continually about the grounds they might be taught to perfect obedience, and close rangings, which are the grand requisites, without trouble or expense. In this way, four or five brace might be easily brought every season to market, and would always command a ready sale, and a price according to the perfection of their breaking.

6646. In the *breeding and rearing* of dogs for the above purposes, it is necessary to observe the greatest care in their original selection; that the breed be of the very best, and one which as it were breaks itself, for this shows the purity of the breed. It is likewise no less necessary that the breed be carefully preserved so: to do which, the moment the dogs begin to smell a bitch, shut her and the intended male closely up, in a confinement inaccessible to other dogs, and there let them remain a fortnight. It is likewise, almost equally necessary, that the dogs peculiarly appropriated to agriculturists, particularly the shepherd's dog, should be bred as pure, for no animal is more liable to sport into varieties. No crossing can on any account be permitted; but choice may be made among families of the same variety. In the rearing of this dog, his education should be early and carefully attended to, to make him hardy and familiar with all the signs of the shepherd; who ought himself to be equal to the regular education of his own dog.

6647. The *diseases of dogs* are very numerous. The following are described by Blaine, as the most prevalent, with their methods of cure.

6648. The *canine asthma* is hardly ever observed to attack any but either old dogs, or those who, by confinement, too full living, and want of exercise, may be supposed to have become diseased by these deviations from a state of nature. It is hardly possible to keep a dog very fat for any great length of time, without bringing it on. This cough is frequently confounded with the cough that precedes and accompanies distemper, but it may be readily distinguished from this by an attention to circumstances, as the age of the animal, its not affecting the general health, nor producing immediate emaciation, and its less readily giving way to medicine.

6649. The *cure* is often very difficult, because the disease has in general been long neglected before it is sufficiently noticed by the owners. As it is in general brought on by confinement, too much warmth, and over-feeding; so it is evident the cure must be begun by a steady persevering alteration in these particulars. The medicines most useful, are alteratives, and of these occasional emetics are the best. One grain of tartarised antimony (*i. e.* tartar emetic) with two, three, or four grains of calomel, is a very useful and valuable emetic. This dose is sufficient for a small dog, and may be repeated twice a week with great success, — always with palliation.

6650. Of *diseases of the eyes*, dogs are subject to almost as great a variety as ourselves, many of which end in blindness. No treatment yet discovered will remove or prevent this complaint.

6651. *Sore eyes*, though not in general ending in blindness, is very common among dogs. It is an affection of the eyelids, is not unlike the scrofulous affection of the human eyelids, and is equally benefited by the same treatment: an unguent made of equal parts of nitrated quicksilver ointment, prepared tully and lard, very lightly applied. Dropsy of the eyeball is likewise sometimes met with, but is incurable.

6652. *Cancer*. The virulent dreadful ulcer, that is so fatal in the human subject, and is called cancer, is unknown in dogs; yet there is very commonly a large scirrhous swelling of the teats in bitches, and of the testicles (though less frequent) in dogs, that as it sometimes becomes ulcerated, so it may be characterised by this name. In the early state of the disease discutients prove useful, as vinegar with salt, and camphor and Spanish flies, with mercurial ointment, have sometimes succeeded; taking care to avoid irritating the part so much as to produce blister. But when the swelling is detached from the belly, and hangs pendulous in the skin, it had better be removed, and as a future preventive suffer the bitch to breed. Scirrhous testicles are likewise sometimes met with; for these no treatment yet discovered succeeds but the removal of the part, and that before the spermatic chord becomes much affected, or it will be useless.

6653. *Colic*. Dogs are subject to two kinds of colic; one arising from constipation of the bowels, the other is of a kind peculiar to dogs, apparently partaking of the nature of rheumatism, and also of spasm. From a sudden or violent exposure to cold, dogs become sometimes suddenly paralytic, particularly in the hinder parts; having great tenderness and pain, and every appearance of lumbago. In every instance of

this kind, there is considerable affection of the bowels, generally costiveness, always great pain. A warm bath, external stimulants, but more particularly active aperients, remove the colic. Colic arising from costiveness, is not in general violently acute from the pain it produces; sometimes, however, it appears accompanied with more spasms than is immediately dependant on the confinement of the bowels. In the former give active aperients, as calomel with pil. cochine, *i. e.* aloetic pill and glysters; in the latter castor oil with laudanum and ether.

6654. *Cough.* Two kinds of cough are common among dogs, one accompanying distemper, the other in an asthmatic affection of the chest. (See 6648. 6355.)

6655. *Distemper.* This is by far the most common and most fatal among the diseases of dogs; hardly any young dog escaping it; and of the few who do escape it in their youth, three-fourths are attacked with it at some period afterwards: it being a mistake that young dogs only have it. It, however, generally attacks before the animal arrives at eighteen months old. When it comes on very early, the chances of recovery are very small. It is peculiarly fatal to greyhounds, much more so than to any other kind of dog, generally carrying them off by excessive scouring. It is very contagious, but it is by no means necessary that there should be contagion present to produce it; on the contrary, the constitutional liability to it is such, that any cold taken may bring it on: and hence it is very common to date its commencement from dogs being thrown into water, or shut out on a rainy day, &c. There is no disease which presents such varieties as this, either in its mode of attack, or during its continuance. In some cases it commences by purging, in others by fits. Some have cough only, some waste, and others have moisture from the eyes and nose, without any other active symptom. Moist eyes, dulness, wasting, with slight cough, and sickness, are the common symptoms that betoken its approach. Then purging comes on, and the moisture from the eyes and nose from mere mucus becomes pus, or matter. There is also frequently sneezing, with a weakness in the loins. When the disease in this latter case is not speedily removed, universal palsy comes on. During the progress of the complaint, some dogs have fits. When one fit succeeds another quickly, the recovery is extremely doubtful. Many dogs are carried off rapidly by the fits, or by purging; others waste gradually from the running from the nose and eyes, and these cases are always accompanied with great marks of putridity.

6656. *The cure.* In the early stages of the complaint give emetics; they are peculiarly useful. A large spoonful of common salt, dissolved in three spoonfuls of warm water, has been recommended; the quantity of salt being increased according to the size of the dog, and the difficulty of making him to vomit. While a dog remains strong, one every other day is not too much: the bowels should be kept open, but active purging should be avoided. In case the complaint should be accompanied with excessive looseness, it should be immediately stopped by balls made of equal parts of gum arabic, prepared chalk, and conserve of roses with rice milk as food. Two or three grains of James's powder may be advantageously given at night, in cases where the bowels are not affected, and in the cases where the matter from the nose and eyes betokens much putridity, we have witnessed great benefits from balls made of what is termed Friars balsam, gum guaiacum, and chamomile flowers in powder: but the most popular remedy is a powder prepared and vended under the name of Distemper Powder, with instructions for the use of it. Dogs, in every stage of the disease, should be particularly well fed. A seton we have not found so useful as is generally supposed; where the nose is much stopped, rubbing tar on the upper part is useful, and when there is much stupidity, and the head seems much affected, a blister on the top is often serviceable.

6657. *Fits.* Dogs are peculiarly subject to fits. These are of various kinds, and arise from various causes. In distemper, dogs are frequently attacked with convulsive fits, which begin with a champing of the mouth and shaking of the head, gradually extending over the whole body. Sometimes an active emetic will stop their progress, but more generally they prove fatal. *Worms* are often the cause of fits in dogs. These deprive the animal wholly of sense; he runs wild till he becomes exhausted, when he gradually recovers, and perhaps does not have one again for some weeks. Confinement produces fits and likewise costiveness. Cold water thrown over a dog will generally remove the present attack of a fit; and for the prevention of their future recurrence it is evident, that the foregoing account of causes must be attended to.

6658. *Inflamed bowels.* Dogs are very subject to inflammation of their bowels, from costiveness, from cold, or from poison. When inflammation arises from costiveness it is in general very slow in its progress, and is not attended with very acute pain, but it is characterised by the want of evacuation and the vomiting of the food taken, though it may be eaten with apparent appetite. In these cases the principal means to be made use of, are the removal of the constipation by active purging, clysters, and the warm bath. Calomel with aloes forms the best purge. But when the inflammation may be supposed to arise from cold, then the removing of any costiveness that may be present is but a secondary consideration. This active kind of inflammation is characterised by violent panting, total rejection of food, and constant sickness. There is great heat in the belly, and great pain; it is also accompanied with great weakness, and the eyes are very red. The bowels should be gently opened with clysters, but no aloes or calomel should be made use of. The belly should be blistered, having first used the warm bath. When the inflammation arises from poison, there is then constant sickness, the nose, paws, and ears are cold, and there is a frequent evacuation of brown or bloody stools. Castor oil should be given, and clysters of mutton broth thrown up, but it is seldom any treatment succeeds.

6659. *Inflamed lungs.* Pleurisy is not an uncommon disease among dogs. It is sometimes epidemic, carrying off great numbers. Its attack is rapid, and it generally terminates in death on the third day, by a great effusion of water in the chest. It is seldom that it is taken in time, when it is, bleeding is useful, and blisters may be applied to the chest.

6660. *Madness.* The symptoms of madness are concisely summed up by Daniel, in the following words: "at first the dog looks dull, shews an aversion to his food and company, does not bark as usual, but seems to murmur; is peevish and apt to bite strangers; his ears and tail drop more than usual, and he appears drowsy; afterwards he begins to loll out his tongue and froth at the mouth, his eyes seeming heavy and watery; if not confined he soon goes off, runs panting along with a dejected air, and endeavors to bite any one he meets. If the mad dog escapes being killed, he seldom runs above two or three days, when he dies exhausted with heat, hunger, and disease. As this is a subject of no slight importance, we shall stand excused for introducing the criteria as described by Blaine, whose account of the disease, founded on long experience and attentive observation, is calculated to remove many unfounded and dangerous prejudices relative to it. He describes it as commencing sometimes by dullness, stupidity, and retreat from observation; but more frequently, particularly in those dogs which are immediately domesticated around us, by some alteration in their natural habits; as a disposition to pick up and swallow every minute object on the ground; or to lick the parts of another dog incessantly; or to lap his own urine, &c. About the second or third day the disease usually resolves itself into one of two types. The one is called raging, and the other dumb madness. These distinctions are not however always clear; and to which is owing so much discrepancy in the accounts given by different persons of the disease.

6661. The *raging madness*, by its term, has led to an erroneous conclusion, that it is accompanied with violence and fury; which, however, is seldom the case: such dogs are irritable and snappish, and will commonly fly at a stick held to them; and are impatient of restraint: but they are seldom violent except when irritated or worried. On the contrary, till the last moment they will often acknowledge the voice of their master and yield some obedience to it. Neither will they usually turn out of their way to bite human persons; but they have an instinctive disposition to do it to dogs; and in a minor degree to other animals also: but as before observed, seldom attack mankind without provocation.

6662. *Dumb madness* is so called, because there is seldom any barking heard, but more particularly, because the jaw drops paralytic, and the tongue lolls out of the mouth, black, and apparently strangulated: a strong general character of the disease, is the disposition to scratch their bed towards their belly; and equally so is the general tendency to eat trash, as hay, straw, wood, coals, dirt, &c.: and it should be remembered, that this is so very common and so invariable; that the finding these matters in the stomach after death, should always render a suspicion formed of the existence of the disease, confirmed into certainty. Blaine is also at great pains to disprove the notion generally entertained, that rabid dogs are averse to water; and neither drink or come near it. This error he contends has led to most dangerous results; and is so far from true, that mad dogs from their heat and fever are solicitous for water, and lap it eagerly. When the dumb kind exists in its full force, dogs cannot swallow what they attempt to lap; but still they will plunge their heads in it, and appear to feel relief by it: but in no instance out of many hundreds, did he ever discover the smallest aversion to it. He lays very great stress on the noise made by rabid dogs, which he says is neither a bark nor a howl, but a tone compounded of both. It has been said by some that this disorder is occasioned by heat or bad food, and by others that it never arises from any other cause but the bite. Accordingly this malady is rare in the northern parts of Turkey, more rare in the southern provinces of that empire, and totally unknown under the burning sky of Egypt. At Aleppo, where these animals perish in great numbers, for want of water and food, and by the heat of the climate, this disorder was never known. In other parts of Africa, and in the hottest zone of America, dogs are never attacked with madness. Blaine knows of no instance of the complaint being cured, although he has tried to their fullest extent, the popular remedies of profuse bleedings, strong mercurial and arsenical doses, vinegar, partial drowning, night shade, water plantain, &c.: he therefore recommends the attention to be principally directed towards the prevention of the malady.

6663. The *preventive treatment of rabies or madness* is, according to Blaine, always an easy process in the human subject, from the immediate part bitten being easily detected; in which case the removal of the part by excision or cautery is an effectual remedy. But, unfortunately for the agriculturist, it is not easy to detect the bitten parts in cattle, nor in dogs; and it would be therefore most desirable if a certain internal preventive were generally known. Dr. Mead's powder, the Ormskirk powder, sea bathing, and many other nostrums are deservedly in disrepute: while a few country medicines, but little known beyond their immediate precincts, have maintained some character. Conceiving that these must all possess some ingredient in common, he was at pains to discover it; and which he appears to have realized by obtaining among others the composition of Webb's Watford drink. In this mixture, which is detailed below, he considers the active ingredient to be the *buxus* or *box*, which has been known as a prophylactic as long as the times of Hippocrates and Celsus, who both mention it. The recipe detailed below has been administered to nearly three hundred animals of different kinds, as horses, cows, sheep, swine, and dogs: and appears to have succeeded in nineteen out of every twenty cases where it was fairly taken and kept on the stomach. It appears also equally efficacious in the human subject; in which case he advises the extirpation of the bitten parts also. The *box* preventive is thus directed to be prepared:

Take of the fresh leaves of the tree-box	2 ounces.
of the fresh leaves of rue	2 ounces.
of sage,	½ ounce.

chop these fine, and boil in a pint of water to half a pint; strain carefully, and press out the liquor very firmly; put back the ingredients into a pint of milk, and boil again to half a pint; strain as before; mix both liquors, which forms three doses for a human subject. Double this quantity is proper for a horse or cow. Two thirds of the quantity is sufficient for a large dog; half for a middling sized, and one third for a small dog. Three doses are sufficient, given each subsequent morning fasting; the quantity directed being that which forms these three doses. As it sometimes produces strong effects on dogs, it may be proper to begin with a small dose, but in the case of dogs we hold it always prudent to increase the dose till effects are evident, by the sickness, panting, and uneasiness of the dog. In the human subject, where this remedy appears equally efficacious, we have never witnessed any unpleasant or active effects, neither are such observed in cattle of any kind. About forty human persons have taken this remedy, and

in every instance it has succeeded equally as with animals: but candor obliges us to notice, that in a considerable proportion of these, other means were used, as the actual or potential cautery: but in all the animals other means were purposely omitted. That this remedy, therefore, has a preventive quality, is unquestionable, and now perfectly established; for there was not the smallest doubt of the animals mentioned either having been bitten, or of the dog being mad who bit them, as great pains were in every instance taken to ascertain these points.

6664. *To prevent canine madness*, Pliny recommends, worming of dogs; and from his time to the present it has had, most deservedly says Daniel, its advocates. He tells us, that he has had various opportunities of proving the usefulness of this practice, and recommends its general introduction. Blaine, on the contrary, asserts, that the practice of worming is wholly useless, and founded in error; and that the existence of any thing like a worm under the tongue is incontestibly proved to be false; and that what has been taken for it, is merely a deep ligature of the skin, placed there to restrain the tongue in its motions. He also observes, that the pendulous state of the tongue in what is termed dumb madness, with the existence of a partial paralysis of the under jaw, by which they could not bite, having happened to dogs previously wormed, has made the inability to be attributed to this source, but which is wholly an accidental circumstance; and happens equally to the wormed and unwormed dog.

6665. *Mange*. This is a very frequent disease in dogs, and is an affection of the skin, either caught by contagion, or generated by the animal. The scabby mange breaks out in blotches along the back and neck, and is common to Newfoundland dogs, terriers, pointers, and spaniels, and is the most contagious. The cure should be begun by removing the first exciting cause, if removable, such as filth or poverty; or, as more general the contrary (for both will equally produce it), too full living. Then an application should be made to the parts, consisting of sulphur and sal ammoniac: tar-lime-water will also assist. When there is much heat and itching, bleed and purge. Mercurials sometimes assist, but they should be used with caution; dogs do not bear them well.

6666. *Worms*. Dogs suffer very much from worms, which, as in most animals, so in them, are of several kinds; but the effects produced are nearly similar. In dogs having the worms the coat generally stares; and the appetite is ravenous, though the animal frequently does not thrive; the breath smells, and the stools are singular, sometimes loose and flimsy, at others hard and dry; but the most evil they produce is occasional fits, or sometimes a continued state of convulsion, in which the animal lingers some time, and then dies; the fits they produce are sometimes of the violent kind, at others they exhibit a more stupid character, the dog being senseless, and going round continually. The cure consists, while in this state, in active purgatives joined with opium, and the warm bath; any rough substance given internally, acts as a vermifuge to prevent the recurrence.

6667. *The worming of whelps* is performed with a lancet, to slit the thin skin which immediately covers the worm; a small awl is then to be introduced under the centre of the worm to raise it up; the farther end of the worm will, with very little force, make its appearance, and with a cloth taking hold of that end, the other will be drawn out easily; care should be taken that the whole of the worm comes away without breaking, and it rarely breaks unless cut into by the lancet, or wounded by the awl.

6668. *The cat* (*Felis catus*, L.) is distinguished from the lion, tiger, leopard, and others of the genus *Felis*, by its annulate tail. Its habits are thus given by Linnæus. Inhabits woods of Europe and Asia; domesticated every where; when tranquil, purrs, moving the tail; when irritated is very active, climbs, spits, emits a foetid odor; eyes shine at night, the pupil by the day a perpendicular line; by night large, round; walks with its claws drawn in; drinks sparingly; urine of the male corrosive; breath foetid; buries its excrements; makes a horrid mewling in its amours; mews after and plays with its kittens; wags its tail when looking after prey; the lion of mice, birds, and the smaller quadrupeds; peaceful among its tribe; eats flesh and fish, refuses hot or salted things, and vegetables; washes behind its ears before a storm; back electric in the dark; when thrown up, falls on its feet; is not infested with fleas; gravid 63 days, brings three to nine young, blind nine days; delight in marum, cat-mint, and valerian.

6669. *The cat is of great use in the farmery* in catching mice, rats, and even birds. It is most desirable to keep males, as where females are kept, the noisy gallantry of the adjoining tom cats is exceedingly annoying.

6670. *The Genet cat* (*Viverra genetta*), is a species of weasel, with an annulate tail, and spotted blackish tawny body. It is a native of Asia, Spain, and France; is mild and easily tamed, and answers all the purposes of a cat at Constantinople and other places.

6671. *The ferret* (*Mustella ferro*, L., fig. 709.), is an animal of the weasel and polecat kind, distinguished by its red fiery eyes. It is a native of Africa, but is tamed in Europe for the purpose of catching rabbits. It procreates twice a year, is gravid six weeks, brings from six to eight young: smells very foetid. The ferret is very susceptible of cold, and must be kept in a box provided with wool, or other warm materials, and may be fed with bread and milk. Its sleep is long and profound, and it awakes with a voracious appetite, which is most highly gratified by the blood of small and young animals. Its enmity to rats and rabbits is unspeakable, and when either are, though for the first time, presented to it, it seizes and bites them with the most phrensied madness. When employed to expel the rabbit from its burrows, it must be muzzled, as otherwise it will suck the blood of its victim, and instantly fall into a profound sleep, from which it will awake only to

709



the work of destruction, committing in the warren, where it was introduced only for its services, the most dreadful waste and havoc. It is possessed of high irritability, and when particularly excited, is attended with an odor extremely offensive.

## CHAP. IX.

### *Of Animals of the Bird kind employed in Agriculture.*

6672. Though *poultry* form a very insignificant part of the live-stock of a farm, yet they ought not to be altogether despised. In the largest farm, a few domestic fowls pick up what might escape the pigs and be lost; and on small farms, and among cottagers, the breeding and rearing of early chickens and ducks, and in some situations the rearing of turkies, and the keeping of geese, are found profitable. There are few who do not relish a new egg or a pancake, not to say the flesh of fowls; and there are some of these comforts which happily can be had in as great perfection in the cottage as in the palace. The various kinds of domestic fowls and birds which are used in agriculture, may be classed as gallinaceous, or with cleft feet; anserine, or web-footed; and birds of fancy or luxury. Before proceeding to the first division, we shall offer some remarks on poultry-hovels.

#### SECT. I. *Of Poultry Houses and their Furniture and Utensils.*

6673. *The situation of the poultry house* should be dry, and exposed either to the east or south-east, so as to enjoy the sun's rays in winter as soon as he appears above the horizon. Though in many cases all the commoner sorts of poultry are lodged in the same apartment, yet to be able to bestow on each species its proper treatment, they ought to be separated by divisions, and enter by separate doors. Apartments for aquatic fowls may be made in part under those of the gallinaceous tribe, and the peacock often prefers roosting on a tree, or on the roof of high buildings, when it forms an excellent watch bird to the poultry yard or farmery.

6674. Where a complete set of poultry houses are intended, then a situation should be fixed on near or close to the farmery, and with ample space around for the fowls to disperse over in the day time, and one or more ponds for the aquatic sorts. A space thirty feet by fifty feet may be made choice of for the buildings and yard (fig. 710.); the building may be ranged along the north side, and the three other sides enclosed with a trellis or wire fence, from six to eight feet in height, and subdivided with similar fences, according to the number of apartments. The hen-house (a), and turkey-house (b), may have their roosts (c c), in part over the low houses for ducks (d) and geese (e), and besides these there may be other apartments (f, g, h) for hatching, or newly hatched broods, for fattening, to serve as an hospital, or for retaining, boiling, or otherwise preparing food, killing poultry, and other purposes. A flue may pass through the whole in moist or very severe weather; the walls should be built hollow in the manner already described, (6304.) which will at the same time be a saving of material; and the windows ought to have outside shutters both for excluding excessive heats and excessive colds. In every apartment there ought to be a window opposite the door in order to create a thorough draught when both are opened, and also a valve in the roof to admit the escape of the hottest and lightest air. Every door ought to have a small opening at bottom for the admission of the fowls when the door is shut. The elevation (fig. 711.) should be in a simple style, and there may be a pigeonry over the central building.

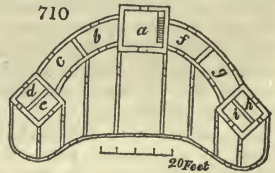

711

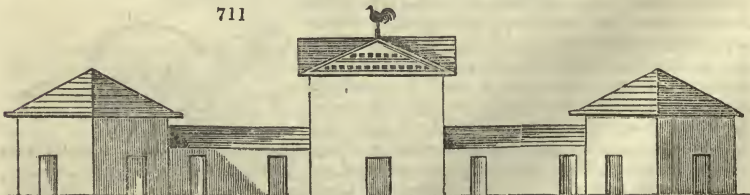

6675. In ordinary cases, where poultry are kept on a farm merely to consume what would otherwise be lost, one or two compartments of the low range of buildings on the south side of the yard are usually devoted to them; or any dry convenient place according to the general plan of the farmery.

6676. *The furniture or fixtures* of the poultry houses are very few; the roost is sometimes a mere floor or loft, to which the birds fly up or ascend by a ladder; at other times it is nothing more than the coupling timbers of the roof, or a series of cross battens; but the most approved mode is a series of rough polygonal or angular battens or rods rising in gradation from the floor to the roof, as already explained, (2682. and 2684.). The battens placed at such a distance horizontally, as that the birds when roosting may not incommode each other by their droppings. For this purpose they should be a foot apart for hens, and eighteen inches apart for turkeys. The slope of the roost may be about 45°. and the lower part should lift up by hinges in order to admit a person beneath to remove the dung. No flying is requisite in the case of such a roost as the birds ascend and descend by steps.

6577. *Nests* are sometimes fixtures, in which case they are niches built against the wall, not unlike wine bins; where there is more than one tier on the ground floor, each superincumbent range must have a projecting balcony in front of about a foot in width, with stairs of ascent at convenient distances.

6678. *A small boiler* for preparing food may sometimes be requisite, though on a small scale this may be done in the kitchen. Watering troughs are generally fixed in the yards. In confined situations there should be a large cistern of sand, in which the fowls may nestle and roll about in order to free themselves from vermin; there should also be a spot composed of gravel, sand, and soft earth, for nearly the same purpose, but more especially for exercising the young chickens. A roof for shelter and protection from the sun may very appropriately be placed over this last compartment, or a part of it.

6679. *The utensils* are the portable nest, (fig. 712 a), coops (b, c), portable shelter (d); feeding

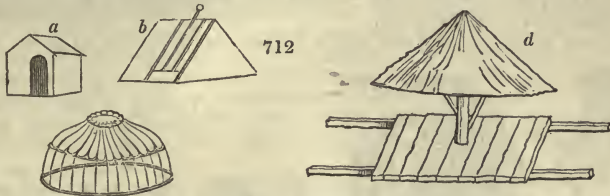

dishes, corn bin for retaining a store of food, egg basket, and feather bags. We avoid enumerating the utensils used in cramming, considering that unwholesome and disgusting practice as unfit for the present age.

SECT. II. *Of Gallinaceous Fowls, their Kinds, Breeding, Rearing, and Management.*

6680. Under the order *Gallinæ*, are included the common hen, turkey, Guinea, and peacock; and we shall here treat of each of these genera in succession.

6681. *The dunghill cock and hen, (Phasianus gallus,)* is a native of the warm countries of the east, and still found in a wild state on the banks of the Phasis (now Rioni) in Georgia; but is now domesticated almost every where. It is both granivorous and carnivorous. The term chicken is applied to the female young of gallinaceous animals, till they are four months old; afterwards they are called pullets, till they begin to lay, when they become hens. The male is a chicken till he is three months old, then he is a cock bird till the age of twelve months, when he becomes a cock; unless indeed he has been artificially deprived of the faculty of procreation, when he becomes a capon, and when the ovarium is taken from a pullet or hen, she is called a hen capon.

6682. *The varieties* of a bird so long under culture may naturally be expected to be numerous; those most esteemed in Britain at the present time, are the following.

6683. *The common dunghill cock and hen,* middle size, of every color, and hardy.

6684. *The gamecock and hen,* (fig. 713.) rather small in size, delicate in limb, color generally red or brown; flesh



white, and superior to that of any other variety for richness and delicacy of flavor;

eggs small, fine shaped, and extremely delicate; the chickens are difficult to rear from their pugnacity of disposition. The game cock has long been a bird both of cruel and curious sport in this as well as other countries, (fig. 714.); but the taste for this amusement, like that for others suited to times of comparative leisure and ignorance, is now happily on the decline in Britain.



6685. *The Dorking cock and hen*, (fig. 715.) so named from the town in Surrey of that name, is the largest variety; shape handsome, body long and capacious, legs short, five claws on each foot; eggs large, and lays abundantly; color of the flesh inclining to yellowish or ivory. Both hens and cocks often made into capons.

6686. *The Poland cock and hen* (fig. 716 a) were originally imported from Holland. The color shining black, with white tops on the head of both cock and hen; head flat, surmounted by a fleshy protuberance, out of which spring the crown feathers, or top, white or black, with the

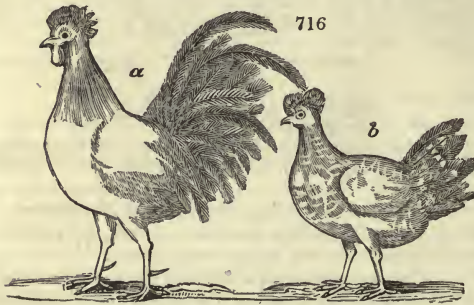

6687. *The every-day cock and hen*, is a subvariety of the above, of Dutch origin; they are of smaller size, and said to be everlasting layers. Their tops are large, and should be periodically clipped near the eyes, otherwise, according to Moubray (*Treatise on Domestic Fowls*, 24 and 115.), they will grow into the eyes of the fowls and render them very subject to alarm.

6688. *The bantam cock and hen* (fig. 717.), is a small Indian breed, valued chiefly for its grotesque figure and delicate flesh. Mowbray mentions a subvariety, extremely small, and as smooth legged as a game fowl. From their size and delicacy they are very convenient, as they may always be used as substitutes for chickens, when small ones are not otherwise to be had. They are also particularly useful for sitting upon the eggs of partridges and pheasants, being good nurses, as well as good layers. There are two varieties of this breed, of which the more common is remarkable for having the legs and feet furnished with feathers. The other, and more scarce variety, is even smaller; and is most elegantly formed, as well as most delicately limbed. There is a society of fanciers of this breed, who rear them for prizes, among which Sir John Sebright stands pre-eminent.



6689. *The Chittagong or Malay hen* (fig. 718.) is an Indian breed, and the largest variety of the species. They are in color, striated yellow and dark brown, long necked, serpent-headed, and high upon the leg; their flesh dark, coarse, and chiefly adapted to soup. They are good layers, and being well fed produce large, substantial, and nutritive eggs; but these birds are too long-legged to be steady sitters.



6690. *The shackbag or Duke of Leeds breed*, was formerly in great repute, but is now nearly lost. It is sometimes to be met with at Wokingham (Oakingham), in Berkshire, and is so large, and the flesh so white, firm, and fine, as to afford a convenient substitute for the turkey.

6691. *The improved Spanish cock and hen* is a cross between the Dorking and Spanish breed, also to be found in and around Wokingham. It is a large bird with black plumage, white and delicate flesh, the largest eggs of any British variety, and well adapted for capons.



6692. *Breeding.* The common variety is easily procurable; but the others must either be procured from those parts of the country where they are usually bred, or from the poulterers and bird fanciers in large towns, and especially in London. It should be a general rule to breed from young stock; a two-year-old cock, or stag, and pullets in their second year. Pullets in their first year, if early birds, will indeed, probably lay as many eggs as ever after; but the eggs are small, and such young hens are unsteady sitters. Hens are in their prime at three years of age, and decline after five, whence, generally, it is not advantageous to keep them beyond that period, with the exception of those of capital qualifications. Hens with a large comb, or which crow like the cock, are generally deemed inferior; but I have had hens with large rose combs, and also crows, which were upon an equality with the rest of the stock. Yellow-legged fowls re often of a tender constitution, and always inferior in the quality of their flesh, which is of a loose flabby texture, and ordinary flavor.

6693. *The health of fowls* is observable in the fresh and florid color of the comb, and the brightness and dryness of the eyes; the nostrils being free from any discharge, and the healthy gloss of the plumage. The most useful cock is generally a bold, active, and savage bird, cruel and destructive in his fits of passion, if not well watched, to his hens, and even to his offspring. Hens above the common size of their respective varieties, are by no means preferable either as layers or setters. The indications of old age are paleness of the comb and gills, dulness of color, and a sort of downy stiffness in the feathers, and length and size of talons, the scales upon the legs becoming large and prominent.

6694. *The number of hens to one cock* should be from four to six, the latter being the extreme number, with a view of making the utmost advantage. Ten and even twelve hens have been formerly allowed to one cock, but the produce of eggs and chickens under such an arrangement will seldom equal that to be obtained from the smaller number of hens. Every one is aware that the spring is the best season to commence breeding with poultry, and in truth it scarcely matters how early, presupposing the best food, accommodation, and attendance, under which hens may be suffered to sit in January.

6695. *The conduct of the cock towards his hens* is generally of the kindest description, and sometimes, as in the Polish breed, so remarkably so, as to be quite incredible to those who have not witnessed it. It is not an uncommon occurrence, however, for the cock to take an antipathy at some individual hen; when it continues for any length of time it is best to remove her, and supply her place by another, taking care that the stranger be not worried by the hens. Spare coops or houses will be found useful on such occasions.

6696. *The change of a cock*, from death or accident, is always attended with interruption and delay, as it may be some considerable time before the hens will associate kindly with their new partner: and further, a new cock may prove dull and inactive from the change, however good in nature. This frequently happens with cocks of the superior breeds, purchased from the London dealers, in whose coops they have been kept in such a high state of temperature, that they are unable to endure the open air of the country, unless in the summer season. Such being removed in autumn, winter, or early in spring, if immediately turned abroad with hens, are liable to become aguish, torpid, and totally useless; perhaps, in the end, turning rousy or glandered. The only method of safety in this case, is to keep such a cock in the house, upon the best and most nourishing food, turning the hens to him several times in the day, and permitting him to be abroad an hour or so, the weather being fine, until in a few weeks, he shall be accustomed to the air.

6697. *In making the nests*, short and soft straw is to be preferred, because, the straw being long, the hen, on leaving her nest, will be liable to draw it out with her claws, and with it the eggs. The hen, it is ascertained, will breed and lay eggs, without the company of a cock; in course, such eggs are barren.

6698. *Eggs for setting* should never exceed the age of a month, the newer to be preferred, as nearly of a size as possible, and of the full middle size; void of the circular flaw, which indicates the double yolk, generally unproductive, nor should there be any roughness or cracks in the shells. The number of eggs, according to the size of the hen, from nine to fifteen, an odd number being preferable, on the supposition of their lying more close. The eggs to be marked with a pen and ink, and examined when the hen leaves her nest, in order to detect any fresh ones which she may have laid, and which should be immediately taken from her, as they, if at all, would be hatched too late for the brood. It is taken for granted the box and nest have been made perfectly clean for the reception of the hen, and that a new nest has not been sluggishly or sluttishly thrown upon an old one, from the filth of which vermin are propagated, to the great annoyance of the hen, and prevention of their steady sitting. Eggs broken in the nest, should be cleared away the instant of discovery, and the remaining washed with warm water, and quickly replaced, lest they adhere to the hen, and be drawn out of the nest; if necessary, the hen's feathers may also be washed, but always with warm water.

6699. With respect to *the capriciousness of some hens*, in the article of sitting, it is a risk which must be left to the judgment of the attendant, who has to determine whether the hen which appears desirous of sitting, may be safely trusted with eggs. Leaving a number of eggs in the nest is an enticement. Very frequently, a hen will cluck, and appear hot for incubation, yet after sitting over her eggs a sufficient number of hours to adde them, will then desert them: and, probably, in the course of a few days will be taken with another fit of incubation. Much useless cruelty is, too often exercised, to prevent the hen

from sitting, when eggs, rather than chickens, are in request. A late author recommends to thrust a feather through the hen's nostrils, in order to prevent her from sitting: and to give her half a glass of gin, then swing her round until seemingly dead, and confine her in a pot, during a day or two, leaving her only a small breathing hole, to force her to sit! It is full time that those and a hundred other such utterly useless and barbarous follies of former days, practised upon various animals, should be dismissed with the contempt they merit. The pamphlet alluded to, is the *Epicure*, by Thomas Young, a publication replete with good things on the interesting subjects of eating, wines, spirits, beer, cider, &c. It is written with *haut gout*. (Mowbray.)

6700. *Moulting*. Every succeeding year after the third, the hen continues to moult later in the season, and laying fewer or no eggs during the moulting period, which is sometimes protracted to two or three months. It should seem that old hens are seldom to be depended upon for eggs in the winter, such being scarcely full of feather until Christmas; and then, probably, may not begin to lay till April, producing at last, not more than twenty or thirty eggs. In general, it is most profitable to dispose of hens whilst they are yet eatable or saleable for that purpose, which is in the spring of the third year. Nor do delicate white hens lay so many eggs in the cold season, as the more hardy colored varieties, requiring warmth and shelter, particularly by night. Moulting, or the casting and renewal of feathers, lasts with its effects from one to three months, according to the age and strength of the bird. Whilst under this natural course, poultry are unfit for the table, as well as for breeding. It is the same with respect to young poultry, whilst shedding their feathers in the spring. The regular moulting of full-grown fowls begins in the autumn.

6701. *In some hens the desire of incubation* is so powerful that they will repeat it five or six times in the year; in others it is so slight, that they will probably not sit more than once or twice in the season. A skilful breeder will take advantage of these qualities, and provide abundance of eggs from the one variety, and of chickens by means of the other. Hens when sitting drink more than usual, and it is an advisable practice to place water constantly before them when in this state, and food (say corn) at least twice a day. The time of incubation is twenty-one days.

6702. *Hatching*. The chicken, hitherto rolled up like a ball, with its bill under the right wing like a bird asleep, begins generally on the morning of the twenty-second day to break its way through the shell, neither the hen, nor can the art of man, with safety render them aid in this very interesting and wonderful operation. The parental affection of the hen, as Mowbray and Parmentier have observed, is always intensely increased, when she first hears the voice of the chicks through the shells, and the strokes of their little bills against them. The signs of a need of assistance, the former author observes, are, the egg being partly pecked, and the efforts of the chicken discontinued for five or six hours. The shell may then be broken cautiously, and the body of the chicken carefully separated from the viscous fluid which lines it. Reaumur gives it as his opinion, that no aid ought to be given to any chickens but those which have been near twenty-four hours employed without getting forward in their work.

6703. *The chickens first hatched* should be taken from the hen, lest she be tempted to leave her task unfinished. Those removed, may be secured in a basket of wool or soft hay, and kept in a moderate heat, if the weather be cold, near the fire. They will require no food for many hours, even four and twenty, should it be necessary to keep them so long from the hen. The whole brood being hatched, the hen is to be placed under a coop abroad, upon a dry spot, and, if possible, not within reach of another hen, since the chickens will mix, and the hens are apt to maim or destroy those which do not belong to them. Nor should they be placed near numbers of young fowls, which are likely to crush young chicks under their feet, being always eager for the chickens' meat. The first food should be split grits, afterwards tail wheat; all watery food, soaked bread, or potatoes, improper. Eggs boiled hard, or curd chopped small, are much approved as first food. Their water should be pure and often renewed, and there are convenient pans made in such forms, that the chickens may drink without getting into the water, which often, by wetting their feet and feathers, numbs and injures them; a bason whelmed in the middle of a pan of water, will answer the end, the water running round it generally; and independent on situation, and the disposition of the hen, there is no necessity for cooping the brood beyond two or three days, but they may be confined as occasion requires, or suffered to range, as they are much benefitted by the scratching and foraging of the hen. They must not be let out too early in the morning, or whilst the dew remains upon the ground, far less be suffered to range over the wet grass, one common and fatal cause of disease. Another caution is of the utmost consequence, to guard them watchfully against sudden unfavorable changes of the weather, more particularly if attended with rain. Nearly all the disorders of gallinaceous fowls arise from cold moisture.

6704. *For the period of the chickens quitting the hen*, there is no general rule, the most certain is, when the hen begins to roost, leaving them; if sufficiently forward, they will follow her, if otherwise, they should be secured in a proper place, the time having

arrived when they are to associate with the young poultry, as nearly of their own age and size as possible, since the larger are apt to overrun and drive from their food the younger brood.

6705. *Hatching by artificial heat* is an Egyptian practice, mentioned by Diodorus and Aristotle, and was brought into notice about the middle of the eighteenth century, by Reaumur in his "*Art de faire eclore &c. des Oiseaux domestiques.*" The requisite degree of heat is 90 degrees, which is supplied by fire, steam, or fermentible substances; after hatching, the birds are placed in a cage, in which is placed a lamb-skin suspended from the roof of a box, and enclosed by a curtain of green baize; or, according to Parmentier, they may be placed under a capon, who after being prepared for receiving pleasure from feeling the chickens under its belly, by depriving it of the greater part of the feathers and excoriation, is to be confined with them in the same coop, and after being fed together for a day or two, it is said the capon will become an excellent nursing mother. Excepting as matter of curiosity, however, it is not at present worth while either to hatch or rear chickens artificially in this country. Whether Reaumur's mode of hatching be adopted, or Mrs. D'Oyley's of depriving hens of their chickens as soon as hatched, and thus causing one hen to hatch five or six broods in succession, the human attention required, and the risk of failure are so great, that the surest modes, under all the present circumstances, are such as are natural. Where it is tried for experiment or curiosity, the heat of tan or dung is more likely to prove steady, than that from smoke, air, or steam. An enclosure in the middle of a broad viney or hot-house might serve at once to hatch and rear early chickens; and such a mode of rearing, at least in the winter season, certainly deserves the attention of those who are curious in having this luxury in February and March.

6706. *The products of the cock and hen* are eggs, feathers, and the carcase.

6707. *Eggs* become desiccated, and, in consequence, lose great part of their substance and nutritive quality, by keeping, and every body knows the value of a fresh-laid egg. They will retain their moisture and goodness, however, three or four months, or more, if the pores of the shell be closed and rendered impervious to the air, by some unctuous application. We generally anoint them with mutton suet melted, and set them on end, wedged close together, in bran, *stratum super stratum*, the containing box being closely covered. Laid upon the side, the yolk will adhere to the shell. They thus come into use, at the end of a considerable period of time, in a state almost equal to new-laid eggs, for consumption, but ought not to be trusted for incubation, excepting in the case of the imported eggs of rare birds.

6708. *The largest eggs* will weigh two ounces and a half, those of the Chittagong hen, perhaps, three ounces. To promote fecundity and great laying in the hen, nothing more is necessary than the best corn and fair water; malted or sprouted barley has occasionally a good effect, whilst the hens are kept on solid corn; but if continued too long they are apt to scour. Cordial horse-hall is good to promote laying in the cold season, and also toast and ale, as every hen-wife well knows. It must be noted, that nothing is more necessary towards success in the particular of obtaining plenty of eggs, than a good attendance of cocks, especially in the cold season; and it is also especially to be observed, that a cock whilst moulting is generally useless. Buffon says, a hen well fed and attended will produce upwards of one hundred and fifty eggs in a year, besides two broods of chickens. Mowbray observed, that a hen generally cackled three or four days previously to laying; and that some half-bred game hens began to lay as soon as their chickens were three weeks old; and the consequence of high keep and good attendance of the cocks.

6709. *Feathers or down* intended for use, should be plucked as soon as possible after the bird is dead, and before it is cold, otherwise they are defective in that elasticity which is their most valuable property, and are liable to decay. The bird should, beside, be in good health, and not moulting, for the feathers to be in perfection; and being plucked, and a sufficient number collected, the sooner they are dried upon the oven, the better, since they are else apt to heat and stick together.

6710. *Where hens are kept more than a year* they are sometimes plucked towards the end of the spring season for the sake of their feathers. This operation, where it takes place, ought to be performed in the most tender and careful manner, and the birds housed afterwards for a time sufficient to enable them to endure the air: but the practice is cruel, and we trust it is not likely to come into general use.

6711. *Feeding and fattening the carcase.* Fowls will become fat on the common run of the farm-yard, where they thrive upon the offals of the stable, and other refuse, with perhaps some small regular daily feeds; but at threshing time, they become particularly fat, and are thence styled barn-door-fowls, probably the most delicate and high flavored of all others, both from their full allowance of the finest corn, and the constant health in which they are kept, by living in a natural state, and having the full enjoyment of air and exercise. They are also confined during a certain number of weeks, in coops, those fowls which are soonest ready being drawn as wanted. It is a common practice with some house-wives, to coop their barn-door fowls for a week or two, under the notion of improving them for the table, and increasing their fat; a practice which, however, seldom succeeds, since the fowls generally pine for their loss of liberty, and slighting their food, lose instead of gaining additional flesh. Such a period, in fact, is too short for them to become accustomed to confinement.

6712. *Feeding-houses,* should be warm and airy, with earth floors well raised, and capacious enough to accommodate twenty or thirty fowls; the floor slightly littered down, and the litter often changed. Sandy gravel and a little lime rubbish should be placed in different places, and often changed. A sufficient number of troughs, for both water and food, should be placed around, that the stock may feed with as little interruption as possible from each other, and perches in the same proportion should be furnished for those birds which are inclined to perch, which few of them will desire, after they have begun to fatten, but which helps to keep them easy and contented until that period. In this

mode fowls may be fattened to the highest pitch, and yet preserved in a healthy state, their flesh being equal in quality to that of the barn-door fowl. To suffer fattening fowls to perch, is contrary to the general practice, since it is supposed to bend and deform the breast-bone; but as soon as they become heavy and indolent from feeding, they will rather incline to rest in the straw; and the liberty of perching in the commencement of their cooping, has a tendency to accelerate that period, when they are more inclined to rest on the floor. Fowls, moreover, of considerable growth, will have many of them become already crooked breasted from perching whilst at large, although much depends upon form in this case, since we find aged cocks and hens of the best shape, which have perched all their lives with the breast bone perfectly straight.

6713. *The privation of light*, by inclining fowls to a constant state of repose, excepting when moved by the appetite for food, promotes and accelerates obesity; but a state of obesity obtained in this way cannot be a state of health; nor can the flesh of animals so fed, equal in flavor, nutriment, and salubrity, that of the same species fed in a more natural way. Economy and market interest may perhaps be best answered by the plan of darkness and close confinement; but a feeder for his own table, of delicate taste, and ambitious of furnishing his board with the choicest and most salubrious viands, will declare for the natural mode of feeding; and in that view, a feeding-yard, gravelled and turfed, the room being open all day, for the fowls to retire at pleasure, will have a decided preference, as the nearest approach to the barn-door system.

6714. *Insects and animal food* form a part of the natural diet of poultry, are medicinal to them in a weakly state, and the want of such food may sometimes impede their thriving.

6715. *For fattening the younger chickens*, the above feeding room and yard is well calculated. These may be put up as soon as the hen shall have quitted her charge, and before they have run off the sucking flesh. For generally when well kept and in health, they will be in fine condition and full of flesh at that period, which flesh is afterwards expended in the exercise of foraging for food, and in the increase of stature, and it may be a work of some time afterwards to recover it, and more especially in young cocks, and all those which stand high upon the leg. In fact, all those which appear to have long legs, should be fattened from the hen, to make the best of them; it being extremely difficult, and often impossible, to fatten long-legged fowls in coops, which, however, are brought to a good weight at the barn-door.

6716. *In the choice of full-sized fowls for feeding*, the short-legged and early hatched always deserve a preference. The green linnet is an excellent model of form for the domestic fowl, and the true Dorking breed approaches the nearest to such model. In course the smaller breeds and the game are the most delicate and soonest ripe. The London chicken butchers as they are termed, or poulterers, are said to be of all others, the most dexterous feeders, putting up a coop of fowls and making them thoroughly fat within the space of a fortnight; using so much grease, and that perhaps not of the most delicate kind, in the food. In the common way, this business is often badly managed, fowls being huddled together in a small coop, tearing each other to pieces, instead of enjoying that repose which alone can ensure the wished-for object; irregularly fed and cleaned, until they are so stench and poisoned in their own excrement, that their flesh actually smells and tastes of it when smoking upon the table. Where a steady and regular profit is required from poultry, the best method, whether for domestic use or sale, is constant high keep from the beginning, whence they will not only be always ready for the table, with very little extra attention, but their flesh will be superior in juiciness and rich flavor, to those which are fattened from a low or emaciated state. Fed in this mode, the spring pullets are particularly fine, and at the same time most nourishing and restorative food. The pullets which have been hatched in March, if high fed from the nest, will lay plentifully through the following autumn, and not being intended for breeding stock, the advantage of their eggs may be taken, and themselves disposed of thoroughly fat for the table in February, about which period their laying will be finished. Instead of giving ordinary and tail corn to fattening and breeding poultry, it will be found most advantageous to allow the heaviest and best, putting the confined fowls upon a level with those fed at the barn door, where they have their share of the weightiest and finest corn. This high feeding shows itself not only in the size and flesh of the fowls, but in the size, weight, and substantial goodness of their eggs, which in those valuable particulars will prove far superior to the eggs of fowls fed upon ordinary corn or washy potatoes; two eggs of the former going further in domestic use than three of the latter. The water also given to fattening fowls should be often renewed, fresh, and clean; indeed, those which have been well kept, will turn with disgust from ordinary food and foul water.

6717. *Barley and wheat are the great dependence for chicken poultry*; oats will do for full grown hens and cocks, but are not so good as barley; both, when they have their fill of corn, will eat occasionally cabbage or beet leaves. Steamed potatoes and oatmeal

mixed together make an excellent mess, but must not be given in great quantities, otherwise it renders the flesh soft and flabby.

6718. *Cramming.* Barley and wheat meal are generally the basis or chief ingredient in all fattening mixtures for chickens and fowls; but in Sussex, ground oats are used, and there oats are in higher repute for fattening than elsewhere, many large hogs being fattened with them. In the report of that county, the Rev. Arthur Young says, "North Chappel, and Kinsford, are famous for their poultry. They are fattened there to a size and perfection unknown elsewhere. The food given them is ground oats made into gruel, mixed with hog's grease, sugar, pot-liquor, and milk: or ground oats, treacle, and suet, sheep's plucks, &c. The fowls are kept very warm, and crammed morning and night. The pot-liquor is mixed with a few handfuls of oatmeal and boiled, with which the meal is kneaded into crams or rolls of a proper size. The fowls are put into the coop, two or three days before they are crammed, which is continued for a fortnight; and they are then sold to the higglers. These fowls, full grown, weigh seven pounds each, the average weight five pounds; but there are instances of individuals double the weight. They were sold at the time of the survey (1809.), at four to five shillings each. Turner, of North Chappel, a tenant of Lord Egremont, crams two hundred fowls per annum. Great art and attention is requisite to cut the capons, and numbers are destroyed in the operation."

6719. *Oakingham in Berks, is particularly famous for fatted fowls,* by which many persons in that town and vicinity gain a livelihood. The fowls are sold to the London dealers, and the sum of 150*l.* has been returned in one market day by this traffic. Twenty dozen of these fowls were purchased for one gala at Windsor, after the rate of half a guinea the couple. At some seasons, fifteen shillings have been paid for a couple. Fowls constitute the principle commerce of the town. Romford, in Essex, is also a great market for poultry, but generally of the store or barn-door kind, and not artificially fed.

6720. *The Oakingham method of feeding* is to confine the fowls in a dark place, and cram them with paste made of barley-meal, mutton-suet, treacle, or coarse sugar, and milk, and they are found completely ripe in a fortnight. If kept longer, the fever that is induced by this continued state of repletion, renders them red and unsaleable, and frequently kills them. Geese are likewise fed in the same neighborhood, in great numbers, and sold about Midsummer to itinerant dealers, the price at the time the survey was made (1808.), two shillings, to two and three-pence each. It appears utterly contrary to reason, that fowls fed upon such greasy and impure mixtures, can possibly produce flesh or fat so firm, delicate, high flavored, or nourishing, as those fattened upon more simple and substantial food; as for example, meal and milk, without the addition of either treacle or sugar. With respect to grease of any kind, its chief effect must be to render the flesh loose and of indelicate flavor. Nor is any advantage gained, excluding the commercial one.

6721. *The methods of cramming by confining in a box* the size of the body of the fowl, and allowing its head and vent to project, for intromission and ejection; of blinding the bird for this purpose; or of nailing it to the board; and also the mode of forcing down liquid food by a particular kind of pump, worked by the foot of the feeder, all these and other cruel practices we wish we could abolish in practice, and obliterate from the printed page.

6722. *Castration* is performed on cocks and hens only in some districts, and chiefly in Berkshire and Sussex. The usual time is when they have left the hen, or when the cocks begin to crow, but the earlier the better. It is a barbarous practice and better omitted. Capons are shunned both by hens and cocks, who it is said will not roost on the same perch with them. The Chinese mode of making capons is fully described and illustrated with cuts in the *Farmer's Magazine*, vol. vi. p. 45.

6723. *Pinioning of fowls* is often practised to restrain them from roosting too high, or from flying over fences, &c.; and is much more convenient than the cutting their wing feathers only. But in the ordinary methods of merely excising the pinion, it is frequently fatal; and almost always so to full grown birds or fowls, by their bleeding to death. To prevent this in the long-winged tribes, as ducks, geese, &c., pass a threaded needle through their wing, close by the inside of the smaller bone, (fig. 719 *a*), and making a ligature with the thread across the larger bone, and returning it on the outside of all, the principal blood vessels are secured, which could not be accomplished by a ligature confined to the surface only. After the blood vessels have been thus secured, cut off the portion of wing beyond the ligature with scissors or shears. In the gallinacea or short winged tribes, as cocks, hens, &c., the operation is rendered safer, by being performed on the beginning of the next joint (*b*), making the ligature embrace all the vessels between these two bones by passing it twice through, and securing each bone individually, and passing the ligature around the whole of that part of the wing generally. In this way also birds which have been accidentally winged in shooting may be preserved.



720

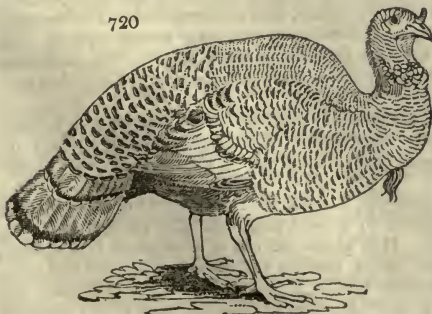

6724. *The turkey, (Meleagris gallinavo, L., fig. 720.)* is a native of America, and

was introduced into this country from Spain soon after the discovery of the former country. The color in the wild state is black, but domestication has produced great variety. In a state of nature they are said to parade in flocks of five hundred, feeding, in general, where abundance of nettles are to be found, the seed of which, and of a small red acorn is their common food in the American woods. They get fat in a wild state, and are soon run down by horses and dogs. They roost on the highest trees, and since the clearing of extensive tracts in America, have become rare in many places: their antipathy to any thing of a red color is well known. In this country they are supposed to be of a tender constitution, which only applies to them when young, for when grown up they will live in the woods with occasional supplies of food, as is actually the case to a great extent in the demesne lands of the Marquis of Bute in Bute.

6725. The *varieties* are few, and chiefly the copper white, said to be imported from Holland, the former too tender for general culture; and the black Norfolk, esteemed superior to all others.

6726. *Breeding.* One turkey cock is sufficient for six hens or more, and a hen will cover according to her size from 9 to 15 eggs. The hen is apt to form her nest abroad in a hedge, or under a bush, or in some insecure place; she lays from eighteen to twenty-five eggs, or upwards, and her term of incubation is thirty days. She is a steady sitter, even to starvation, and therefore requires to be regularly supplied with food and water. Buffon says she is a most affectionate mother; but Mowbray observes that from her natural heedlessness and stupidity, she is the most careless of mothers, and being a great traveller herself, will drag her brood over field, heath, or bog, never casting a regard behind her to call in her straggling chicks, nor stopping while she has one left to follow her. The turkey differs from the common hen in never scratching for her chicks, leaving them entirely to their own instinct and industry, neither will they fight for their brood, though vigilant in the discovery of birds of prey, when they will call their chickens together by a particular cry, and run with considerable speed. Hence, when not confined within certain limits, they require the attendance of a keeper.

6727. *Turkey chicks* should be withdrawn from the nest as soon as hatched, and kept very warm by wrapping them in flannel, or putting them under an artificial mother in a warm room or other warm place. Various nostrums are recommended to be given and done at this season, as a peppercorn, and a tea spoonful of milk, immersion in cold water, &c. Mowbray wisely rejected all these unnatural practices, and succeeded by giving curd and hard eggs, or curd and barley meal kneaded with milk, and renewed with clear water rather than milk, as he found the last often scoured them. A sort of vermiceli, or artificial worms, made from pulling boiled meat into strings, he found beneficial for every species of gallinaceous chicken. Two great objects are to avoid superfluous moisture, and to maintain the utmost cleanliness, for which purposes as little slop food is given as possible. A fresh turf of short sweet grass should be daily given as green food, but not snails or worms, as scouring, and no oats; nettle seed, clover, rue, or wormwood gathered, as recommended by the elder housewives. Water is generally preferable to milk. When the weather is favorable, the hen is cooped abroad in the forenoon. During the rest of the day and night, for the first six weeks, she is kept within doors. After this the hen may be cooped a whole day externally for another fortnight, to harden the chickens; and afterwards they may be left to range within certain limits, or tended by an old man or woman, being fed at going out in the morning and returning in the evening. Their ordinary food may be that of the common cocks and hens. They will prefer roosting abroad upon high trees in the summer season, but that cannot generally be permitted with a view to their safe keeping.

6728. *Fattening.* Sodden barley, or barley and wheat-meal mixed, is the most approved food; and the general mode of management is the same as that of the common cock and hen. They are generally fed so as to come in at Christmas, but they may be fattened early or late. Sometimes, though but rarely, they are caponized. Buffon says, the wild turkey of America has been known to attain the weight of sixteen pounds; the Norfolk turkeys are said sometimes to weigh twenty and thirty pounds; but Mowbray says, he never made any higher than fifteen pounds ready for the spit. The living and dead weight of a turkey are as 21 to 14.

6729. *Feathers.* Turkeys are sometimes plucked alive, a barbarous practice which ought to be laid aside. Parmentier proposed to multiply the breed of white turkeys in France, and to employ the feathers found on the lateral part of the thighs, instead of the plumes of the ostrich.

6730. *The Guinea hen* (*Numidia meleagris*, L., fig. 721.), is a native of Guinea, and found in various parts of South America in a wild state, where it perches on trees, and builds its nest in the palm-tree. It is about the size of a common hen, gregarious, and often found in large flocks; active, restless, and courageous; and will even attack the turkey, though so much above its size. This bird has been said to unite the properties of the pheasant and the turkey; its flesh is more like that of the pheasant

than that of the common cock and hen both in color and taste, and is reckoned a very good substitute for the former bird. It is also very prolific, and its eggs are nourishing and good. It assimilates perfectly with common fowls in its artificial habits and kinds of food; but it has this peculiarity—that the cocks and hens are so nearly alike, that it is difficult to distinguish them, and it has a peculiar gait, and cry, and chuckle.

6731. *The peacock (Pavo cristatus, L.)* is a native of India, and found in a wild state in Java and Ceylon, where they perch on trees like the turkey in America. The age of the peacock extends to twenty years, and at three the tail of the cock is full and complete. The cock requires from three to four hens; and where the country agrees with them, they are very prolific, a great ornament to the poultry-yard and lawn, and useful for the destruction of all kinds of reptiles. Unfortunately, they are not easily kept within moderate bounds, and are very destructive in gardens. They live on the same food as other domestic fowls, and prefer barley. They are in season from February till June; but though a peacock forms a very showy dish, the flesh is ill-colored and coarse, and they are therefore kept more as birds of ornament than of use.



SECT. III. *Anserine, or Aquatic Fowls.*

6732. The order *anserines* comprehends the duck, goose, swan, and buzzard. Under a regular system, Mowbray observes, it would be preferable to separate entirely the aquatic from the other poultry, the former to have their houses ranged along the banks of a piece of water, with a fence, and sufficiently capacious walks in front; access to the water by doors to be closed at will. Should the water be of considerable extent, a small boat would be necessary, and might be also conducive to the pleasure of angling.

6733. *The duck (Anas boschus, L., fig. 722.)* is a native of Britain, and found frequenting the edges and banks of lakes in most parts of Europe. The flesh of this and various other species of the duck is savory and stimulant, and said to afford preferable nourishment to that of the goose, being less gross, and more easily digested. The flesh of the wild duck, though more savory than that of the tame, is reckoned still more easy of digestion. The ancients went even beyond our greatest modern epicures in their high esteem for the flesh of the duck, and Plutarch asserts, that Cato preserved his whole household in health by dieting them on duck's flesh.

6734. *Varieties and species.* There are the *Rhone*, the *Aylesbury*, the *Canvass-backed*, and the *Muscovy*.

6735. *The Rhone duck* is originally from France, and generally of a dark-colored plumage, large size, and supposed to improve our breed. They are of darker flesh, and more savory than the English duck; but somewhat coarse. Rhone-ducks have been so constantly imported for a great number of years, that they are very generally mixed with our native breed. The English duck, particularly the white variety, especially when they chance to have light-colored flesh, are never of so high and savory flavor as the darker colors. Muscovy and other foreign species of the duck, are kept rather out of curiosity than for the table.

6736. *The white Aylesbury* are a beautiful and ornamental stock, matching well in color with the Embden geese. They are said to be early breeders.

6737. *The canvass-backed*, bred only on the Potowmac and Susquehanna rivers, are of very recent introduction from America, and are only to be found in a few places near Liverpool; they are said to be the best in the world, and if so will soon become better known.

6738. *The Muscovy duck (A. Moschata, L.)*, is a native of Brazil, but domesticated in Europe. It is a curious dark-colored bird, distinguished by its naked face, kept more out of curiosity than use; to be retained in any place, they must be reared there from the egg, otherwise they will fly away.

6739. *Breeding.* One drake is generally put to five ducks; the duck will cover from eleven to fifteen eggs, and her term of incubation is thirty days. They begin to lay in February, are very prolific, and are apt, like the turkey, to lay abroad, and conceal their eggs, by covering them with leaves or straws. The duck generally lays by night, or early in the morning; white and light-colored ducks produce similar eggs, and the brown and dark-colored ducks, those of a greenish blue color, and of the largest size. In setting ducks, it is considered safest to put light-colored eggs under light ducks, and the



contrary; as there are instances of the duck turning out with her bill those eggs which were not of her natural color.

6740. During *incubation*, the duck requires a secret and safe place, rather than any attendance, and will, at nature's call, cover her eggs, and seek her food, and the refreshment of the waters. On hatching, there is not often a necessity for taking away any of the brood, barring accidents; and having hatched, let the duck retain her young upon the nest her own time. On her moving with her brood, prepare a coop upon the short grass, if the weather be fine, or under a shelter, if otherwise: a wide and flat dish of water, often to be renewed, standing at hand; barley, or any meal, the first food. In rainy weather particularly, it is useful to clip the tails of the ducklings, and the surrounding down beneath, since they are else apt to draggle and weaken themselves. The duck should be cooped at a distance from any other. The period of her confinement to the coop, depends on the weather and the strength of the ducklings. A fortnight seems the longest time necessary; and they may be sometimes permitted to enjoy the pond at the end of a week, but not for too great a length at once, least of all in cold wet weather, which will affect, and cause them to scour and appear rough and dragged. In such case they must be kept within a while, and have an allowance of bean or pea-meal mixed with their ordinary food. The meal of buck-wheat and the former is then proper. The straw beneath the duck should be often renewed, that the brood may have a dry and comfortable bed; and the mother herself be well fed with solid corn, without an ample allowance of which, ducks are not to be reared or kept in perfection, although they gather so much abroad.

6741. *Duck eggs are often hatched by hens*, when ducks are more in request than chickens; also as ducks, in unfavorable situations, are the more easy to rear, as more hardy; and the plan has no objection in a confined place, and with a small stock, without the advantage of a pond; but the hen is much distressed, as is sufficiently visible, and, in fact, injured, by the anxiety she suffers in witnessing the supposed perils of her children venturing upon the water.

6742. *Ducks are fattened*, either in confinement, with plenty of food and water, or full as well restricted to a pond, with access to as much solid food as they will eat; which last method is preferable. They fatten speedily, in this mode, mixing their hard meat with such a variety abroad as is natural to them, more particularly, if already in good case; and there is no check or impediment to thrive from pining, but every mouthful tells and weighs its due weight. A dish of mixed food is preferable to white corn, and may remain on the bank, or rather in a shed, for the ducks. Barley, in any form, should never be used to fatten ducks or geese, since it renders their flesh loose, woolly, and insipid, and deprives it of that high savory flavor of brown meat, which is its valuable distinction; in a word, rendering it chickeny, not unlike in flavor the flesh of ordinary and yellow-legged fowls. Oats, whole or bruised, are the standard fattening material for ducks and geese, to which may be added pea-meal, as it may be required. The house-wash is profitable to mix up their food, under confinement; but it is obvious, whilst they have the benefit of what the pond affords, they can be in no want of loose food. Acorns in season, are much affected by ducks which have a range; and they will thrive so much on that provision, that the quantity of fat will be inconvenient, both in cooking, and upon the table. Ducks so fed, are certainly inferior in delicacy, but the flesh eats high, and is far from disagreeable. Fed on butcher's offal, the flesh resembles wild fowl in flavor, with, however, considerable inferiority. Offal-fed duck's flesh does not emit the abominable stench which issues from offal-fed pork. When live ducks are plucked, only a small quantity of down and feathers should be taken from each wing.

6743. *Decoys for wild ducks*. Wild ducks, and other aquatic birds, are frequently taken by the device termed a decoy, which, in the low parts of Essex, and some other marshy districts, may be considered as connected with husbandry. A decoy is a canal or ditch, provincially pipe, of water (*fig. 723.*), with a grassy sloping margin (1) at its junction with a river or larger piece of water (8), to invite aquatic fowls to sit on and dress their plumage; but in other parts, covered with rushes and aquatic plants for concealment. Along the canal of the decoy are placed reed fences (2, 2), to conceal the decoy-man and his dogs from the sight of the ducks. There is an opening in this fence (3), where the decoy-man first shows himself to the birds to force them to take the water; and having taken it, the dog drives them up the canal, the man looking through the fence at different places (4, 5, 6) to frighten them forward. At the end of the canal is a tunnel net (7), where the birds are finally taken. In operating with this trap, as the wild duck is a very shy bird, and delights in retirement, the first step is to endeavor to make the given water a peaceful asylum, by suffering the ducks to rest on it undisturbed. The same love of concealment leads them to be partial to waters whose margins abound with underwood and aquatic plants; hence, if the given water is not already furnished with these appendages, they must be provided; for it is not retirement alone which leads them into these recesses, but a search after food also. At certain



times of the day, when wild fowl are off their feed, they are equally delighted with a smooth, grassy margin, to adjust and oil their plumage upon. On the close-



pastured margins of large waters, frequented by wild fowl, hundreds may be seen amusing themselves in this way; and perhaps nothing draws them sooner to a water than a conveniency of this kind: hence, it becomes essentially necessary to success, to provide a grassy, shelving, smooth-shaven bank (1) at the mouth of the decoy, in order to draw the fowl, not only to the water at large, but to the desired part of it. Having, by these means, allured them to the mouth of the decoy; the difficulties that remain are, those of getting them off the bank into the water, without taking wing, and of leading them up the canal to the snare which is set for them in the most easy manner.

6744. In order to get them off the bank into the water, a dog is necessary (the more like a fox the better), which should steal from behind the skreen of reeds, (2, 2,) which is placed by the side of the canal to hide the decoy-man as well as his dog, until the signal be given. On seeing the dog, the ducks rush into the water; where the wild fowl consider themselves as safe from the enemy which had assailed them, and of course do not take wing. Among the wild fowl, a parcel (perhaps eight or ten) of decoy-ducks should be mixed, which will probably be instrumental in bringing them, with greater confidence, to the bank. As soon as these are in the water, they make for the decoy, at the head of which they have been constantly fed, and in which they have always found an asylum from the dog. The wild ducks follow; while the dog keeps driving behind; and, by that means, takes off their attention from the trap they are entering. When, as soon as the decoy-man, who is all the while observing the operation through peep-holes in the reed skreen, sees the entire shoal under a canopy net which covers and incloses the upper part of the canal, he shews himself, when the wild fowl instantly take wing, but their wings meeting with an impervious net, instead of a natural canopy, formed of reeds and bulrushes, they fall again into the water, and, being afraid to recede, the man being close behind them, they push forward into the tail of the tunnel net, which terminates the decoy. In this way, nine dozen have been caught at a time.

6745. The form of the pipe or canal ought to resemble the outlet of a natural brook, or a natural inlet or creek of the principal water. The mouth ought to be spacious, and free from confinement, that the wild fowl, on their first rushing into the water, and while they have yet the power of recollection, may be induced to begin to follow the tame ducks; and for the same purpose it ought to be crooked, that its inward narrowness, and the nets, may not, in the first instance, be perceived. The lower part of a French horn is considered as the best form of the canal of a decoy that can be had. A material circumstance remains yet to be explained. It is the invariable nature of wild fowl to take wing with their heads toward the wind; and it is always imprudent to attempt to take them in a decoy, unless the wind blow down the pipe; for, while their enemy is to leeward of them, they have less scruple to go up the pipe, making sure of an escape by their wings. But, what is of still more consequence, if the wind set up the pipe when they take wing under the canopy net, some of them would probably escape (a circumstance always to be dreaded), and those which fell again into the water, would fall, of course, with their heads toward the wind, and would, with greater difficulty, be driven into the tunnel. This point is so well known by decoy-men in general, that every decoy is, when circumstances will admit of it, furnished with three or four different canals, pointing to distinct quarters of the horizon, that no opportunity may be lost on account of the wind being in any particular point.

724



6746. The goose (*Anas anser*, L., fig. 724.) is a native of Britain, and most parts of the north of Europe, but less common than the duck. The flesh of the common and various species of geese is highly stimulant, strong in flavor, viscous, and of a putrescent tendency. The flesh of the tame goose is more tender than that of the wild, which tastes of fish, but either kind is only adapted for good stomachs, and powerful digestion, and should be sparingly used by the sedentary and weak, or persons subject to cutaneous diseases. The fat of the goose is reckoned peculiarly subtle, penetrating, and resolvent, and is generally carefully preserved for domestic applications. The goose attains to a great age,

well authenticated instances being on record to the extent of 70 and 80 years. The best geese in England are probably to be found on the borders of Suffolk and Norfolk, and in Berkshire; but the greatest numbers are in Lincolnshire, whence they are sent in droves to London to be fed by the poulterers, some of whom fatten in the vicinity of the metropolis above five thousand in a season.

6747. Of *varieties and species* there are several, the former differing in color, as black, white, and grey, and also in size. There is also the Spanish white goose, and large white Embden goose, the latter in most esteem. When one has seen a wild goose, says Pennant, a description of its plumage will, to a feather, exactly correspond with any other. But in the tame kinds, no two of any species are exactly alike; different in their size, their colors, and frequently in their general form, they seem the mere creatures of art; and having been so long dependent upon man for support, they seem to assume forms entirely suited to his necessities.

6748. There is a *Chinese species* (*A. cygnoides*), and an American goose (*A. canadensis*). The Chinese species is a domestic bird, but as yet little known in this country. It is longer and narrower in the body than the common goose, and stands higher on the legs. The Canadian goose is domesticated in several places, and is not considered uncommon in England. It is the most ornamental of the goose kind on water in pleasure grounds, and is abundant in the Duke of Devonshire's park at Chiswick.

6749. *Breeding.* One gander is generally put to five geese: the goose lays from eleven to fifteen eggs; and the period of incubation is from twenty-seven to thirty days. A nest should be prepared as soon as the female begins to carry straw in her bill, and by other tokens declares her readiness to lay. This is generally in March, and sometimes two broods are produced within the season, an advantage obtainable by high feeding through the winter with sound corn, and on the commencement of the breeding season allowing them boiled barley, malt, fresh grains, and fine pollard mixed up with ale or other stimulants. A good gander sits near his geese whilst they are sitting, and vigilantly protects them. Feeding upon the nest is seldom required; and it is unnecessary to take any of the goslings from the mother as hatched; but pen the goose and her brood at once upon dry grass well sheltered, putting them out late in the morning, or not at all in severe weather, and ever taking them in early in the evening. The first food may be similar to that recommended for the duck, such as barley meal, bruised oats, or fine pollard, with some cooling green vegetables, as cabbage or beet leaves intermixed.

6750. *Rearing.* At first setting at liberty, the pasturage of the goose should be limited, otherwise, if allowed to range over an extensive common, the gulls or goslings will become tired and cramped, and some of them will fall behind and be lost. Mowbray advises to destroy all the hemlock and nightshade in their range, and he says he has known them killed by swallowing sprigs of yew. As the young become pretty well feathered, they become also too large to be brooded beneath the mother's wing, and as they will then sleep in groups by her side, they must be well supplied with straw beds, which they will convert into excellent dung. Being able, says Mowbray, to frequent the pond and range the common at large, the young geese will obtain their living, and few people, favorably situated, allow them any thing more, excepting the vegetable produce of the garden. But it has been his constant practice, always to dispense a moderate quantity of any solid corn or pulse at hand, to the flocks of store geese, both morning and evening, on their going out, and their return, together, in the evening more especially, with such greens as chanced to be at command: cabbage, mangel-wurzel leaves, lucern, tares, and occasionally sliced carrots. By such full keeping his geese were ever in a fleshy state, and attained a large size; the young ones were also forward and valuable breeding stock. Geese managed on the above mode, will be speedily fattened green, that is, at a month or six weeks old, or after the run of the corn stubbles. Two or three weeks after the latter, must be sufficient to make them thoroughly fat. A goose fattened entirely on the stubbles, is to be preferred to any other; since an over-fattened goose is too much in the oil-cake and grease-tub style, to admit even the ideas of delicacy, tender firmness, or true flavor. But when needful to fatten them, the feeding-houses already recommended for hens (6712.) are most convenient. With clean and renewed beds of straw, plenty of clean water, oats, crushed or otherwise, pea or bean meal (the latter, however, coarse and ordinary food), or pollard mixed up with skimmed milk, geese will fatten pleasantly and speedily.

6751. *Feathers.* Pennant, in describing the methods used in Lincolnshire in managing geese, says, "they are plucked five times in the year; first at Lady-day for the feathers and quills, and four times for the feathers only, between that and Michaelmas." He says, he saw the operation performed on goslings of six weeks old, from which the feathers of the tails were plucked, and that numbers die of the operation, if the weather immediately afterwards proves cold. Lean geese furnish the greatest quantity of down

and feathers, and of the best quality. This seems a cruel practice, and surely were better left off.

6752. *The swan*, (*Anas olor*, L., fig. 725.) is a native of England, but not common; it is chiefly found on the Thames and the Trent. In former times the swan formed a dish of embellishment at great feasts; but now the cygnets, or young only are eaten, and that after a peculiar preparation. Formerly they were fattened at Norwich for the city feast, and commanded a guinea each. The foot of the swan possesses nearly the same property as that of the goose; and the skin was formerly held to contain medical properties. At present swans are chiefly to be considered as ornamental in pleasure grounds, clearing water from weeds, and occasionally affording cygnet and some swan down feathers and quills. It is a curious circumstance that the ancients considered the swan as a high delicacy, and abstained from the flesh of the goose as impure and indigestible.

6753. *Varieties or species*. The common swan differs in color; the black is rare, as every schoolboy knows. The swan goose, Muscovy goose (*A. hybrida*, L.), is a native of Guinea, and is a sort of middle species between the swan and the goose, and unites so well with the latter as to cause little or no perceptible difference in the progeny. They are sufficiently common in England, and distinguished by their erect gait, and the screaming which they continue during almost the whole day, without any obvious incitement.

6754. *Rearing*. The swan feeds like the goose, and has the same familiarity with its keepers, kindly and eagerly receiving bread which is offered, although it is a bird of courage equal to its apparent pride, and both the cock and hen are extremely dangerous to approach during incubation, or whilst their brood is young, as they have sufficient muscular force to break a man's arm with a stroke of their wing. They both labor hard in forming a nest of water plants, long grass, and sticks, generally in some retired part or inlet of the bank of the stream, or piece of water on which they are kept. The hen begins to lay in February, producing an egg every other day, until she has deposited seven or eight, on which she sits six weeks, although Buffon says it is nearly two months before the young are excluded. Swans' eggs are much larger than those of a goose, white, and with a hard, and sometimes tuberosus shell. The cygnets are ash-colored when they first quit the shell, and for some months after; indeed, they do not change their color, nor begin to moult their plumage, until twelve months old, nor assume their perfect glossy whiteness, until advanced in their second year.

6755. *Feathers and down*. Where the living swan is plucked, only the ripe down should be taken from each wing, and four or five feathers. This may be repeated to the extent of three times in the course of a summer.

6756. *The bustard*, (*Otis tarda*, L., fig. 726.), is a native of England, the largest indigenous land bird in Europe; the cock generally weighing from twenty-five to twenty-seven pounds. The neck a foot long, the legs a foot and a half. It flies with some little difficulty. The head and neck of the cock ash colored; the back barred transversely with black and bright rust color. The greater quill feathers black, the belly white; the tail, consisting of twenty feathers, marked with broad black bars: it has three thick toes before and none behind. There are upwards of half a dozen species of this bird, two or three of which (African) are crested. The little bustard (*O. tetrax*), differs chiefly in size, not being larger than a pheasant. Bustards were known to the ancients in Africa, and in Greece and Syria; are supposed to live about fifteen years; are gregarious, and pair in spring, laying only two eggs, nearly of the size of a goose-egg, of a pale olive brown, marked with spots of a darker hue. They sit about five weeks, and the young ones run, like partridges, as soon as delivered from the shell. The cocks will fight until one is killed or falls. Their flesh has ever been held most delicious; they are fed upon the same food as the turkey. There were formerly great flocks of bustards in this country, upon the wastes and in the wolds, particularly in Norfolk, Cambridgeshire, and Dorset, and in various parts of Scotland, where they were hunted with greyhounds, and were easily taken. Buffon was mistaken in his supposition that these birds are incapable of being propagated in the do-



mestic state, chiefly on account of the difficulty of providing them with proper food, which, in their wild state, he describes to be heath-berries and large earth-worms. Probably the haw or white-thorn berry might succeed equally well. To those who aim at variety and novelty in this line, the bustard appears peculiarly an object for propagation and increase, since the flesh is of unrivalled excellence; and it is probable this fowl will render great weight of flesh for the food consumed.

#### SECT. IV. Diseases of Poultry.

6757. *The diseases of poultry* are generally the result of improper nourishment and lodging, and the best mode of cure is by the immediate adoption of such as is proper. When that will not succeed, very little help can be derived from medical assistance; at least as that art stands at present with respect to poultry. In fact, as Mowbray observes, the far greater part of that grave and plausible account of diseases to be found in our common cattle and poultry books is a farrago of absurdity, the chief ground of which is random and ignorant guess-work.

6758. *Common fowls* are attacked by the pip, roup or catarrh, the flux, constipation, and vermin. The pip is an outside skin or scale, growing on the tip of the tongue, and is cured by tearing off the skin with the nail and rubbing the tongue with salt. Imposthume on the rump is called the roup, which term is also applied to catarrh, to which gallinaceous fowls are very subject. The imposthume is to be opened, the core thrust out, and the part washed with salt and water. Generous food and warmth is the only cure in the catarrh. The flux is to be cured with good solid food, and its opposite, constipation with scalded bran mixed with skim-milk or pot liquor, adding a small quantity of sulphur. Vermin appear in consequence of low keep, and want of cleanliness; the simplest remedy is to allow plenty of sand and ashes for the birds to roll in, and to keep their houses and roosts sweet and clean, white-washing them two or three times a year.

6759. *But the catarrh* is the chief disease to which chickens and fowls are liable; and when the malady becomes confirmed with running at the nostrils, swollen eyes, &c. they are termed roup, and the disease is infectious. They should now be separated and kept in a warm apartment and well fed. Roup hens seldom lay, and their eggs are unwholesome. In chickens this disease is called the chip; they are seen shivering, pining, and dying in corners, apparently from cold, though they are in fact in a fever. Abundant warmth and rich food, are the only remedies.

6760. *Broken legs, wings, or toes,* may be set and spliced, and will recover; the head being raw and the eyes blinded from fighting, wash the eyes with milk and water, and the head alternately with brandy in which is a few drops of laudanum, and with fresh butter. A cock's spurs being too long, impeding his walk and wounding his legs, they should be cut carefully with a sharp pen-knife, but not too near the quick, every three months.

6761. *Geese* are subject to the gargle, or stoppage in the head, the consequence of cold. House the patient, and give garlick beat up with fresh butter; or toast and ale with a little confinement will succeed equally well.

6762. *All poultry,* when young, are apt to be carried off by rats, and other vermin, which must either be vigilantly guarded against, or destroyed.

#### SECT. V. Of Birds of Luxury, which are, or may be, cultivated by Farmers.

6763. *Birds of luxury* include the pigeon, pheasant, partridge, quail, singing birds, and birds kept as curious objects.

6764. *Of the pigeon, (Columba, L.)* there are three species, and many varieties in cultivation. The species are, the common, ring, and turtle-doves, all natives of Britain. The varieties of the common pigeon, enumerated by Linnæus, amount to twenty-one; but those of the pigeon fanciers to more than double that number. The ring-dove (*C. palumbus, L.*), and the turtle-dove (*C. turtur*), with the greater number of the varieties, are cultivated only by a few persons known as pigeon fanciers: but the common pigeon of different colors is cultivated for the table. The flesh of the young pigeon is very savory and stimulating, and highly valued for pies; that of the full aged pigeon is more substantial, harder of digestion, and in a considerable degree heating. Black or dark feathered pigeons are dark fleshed, and of high flavor, inclining to the game bitter of the wild pigeon. Light colored feathers denote light and delicate flesh. The dung of pigeons is used for tanning upper leathers for shoes; it is also an excellent manure. Pigeons are now much less cultivated than formerly, being found injurious to corn fields, and especially to fields of peas. They are, however, very ornamental; a few may be kept by most farmers, and fed with the common poultry, and some who breed domestic fowls on a large scale, may, perhaps, find it worth while to add the pigeon to their number.

6765. *The variety of pigeon* most suitable for the common pigeon-house, is the grey pigeon (*fig. 727.*), inclining to ash-color and black; which generally shews fruitfulness by the redness of the eyes and feet, and by the ring of gold color which is about the neck.

6766. *The varieties* of the fancy breeders are numerous, and distinguished by a variety of different names, as carriers (*fig. 728 a*); coppers, pouters, horsemen, runts, jacobines, turbits, helmets, nuns, tumblers (*b*); barbs, petits, owls, spots, trumpeters, shakers, turners, finikins, &c. From these, when differently paired, are bred bastard pigeons; thus



from the cropper or powter, and the carrier, is bred the powting horse-men (c); from the tumbler and the horse-men, dragons, &c.



6767. The stocking of pigeon-houses is best performed in May or August, as the birds are then in the best condition. Young birds called squeakers should be chosen, as the old are apt to fly away.

6768. In breeding, the pigeon lays two white eggs, which produce young ones of different sexes. When the eggs are laid, the female sits fifteen days, not including the three days she is employed in laying, and is relieved at intervals by the male. The turns are generally pretty regular. The female usually sits from about five in the evening till nine the next morning; at which time the male supplies her place, while she is seeking refreshment abroad. Thus they sit alternately till the young are hatched. If the female does not return at the expected time, the male seeks her, and drives her to the nest; and should he in his turn be neglectful, she retaliates with equal severity. When the young ones are hatched, they only require warmth for the first three days; a task which the female takes entirely upon herself, and never leaves them except for a few minutes to take a little food. After this they are fed about ten days, with what the old ones have picked up in the fields, and kept treasured in their crops, from whence they satisfy the craving appetite of their young ones, who receive it very greedily. This way of supplying the young with food from the crop, in birds of the pigeon-kind, differs from all others. The pigeon has the largest crop of any bird, for its size; which is also quite peculiar to the kind. In two that were dissected by an eminent anatomist, it was found that, upon blowing the air into the windpipe, it distended the crop or gullet to an enormous size. Pigeons live entirely upon grain and water; these being mixed together in the crop, are digested in proportion as the bird lays in its provision. Young pigeons are very ravenous, which necessitates the old ones to lay in a more plentiful supply than ordinary, and to give it a sort of half maceration in the crop, to make it fit for their tender stomachs. The numerous glands, assisted by air and the heat of the bird's body, are the necessary apparatus for secreting a sort of pap, or milky fluid (commonly called pigeon's milk), but as the food macerates, it also swells, and the crop is considerably dilated. If the crop were filled with solid substances, the bird could not contract it; but it is obvious the bird has the power to compress its crop at pleasure, and, by discharging the air, can drive the food out also, which is forced up the gullet with great ease. The young usually receives this tribute of affection from the crop three times a day. The male for the most part feeds the young female, and the old female performs the same service for the young male. While the young are weak, the old ones supply them with food macerated suitable to their tender frame; but, as they gain strength, the parents give it less preparation, and at last drive them out, when a craving appetite obliges them to shift for themselves; for when pigeons have plenty of food, they do not wait for the total dismission of their young; it being a common thing to see young ones fledged, and eggs hatching at the same time and in the same nest.

6769. The terms applied to pigeons of different ages are, the youngest, when fed by the cock and hen, squabs, at which age they are most in demand for pies. Under six months of age, they are termed squeakers; at that age they begin to breed, and then, or earlier, they are in the fittest state for removal to a strange situation.

6770. In respect to food, pigeons are entirely granivorous, and very delicate and cleanly in their diet; they will sometimes eat green aromatic vegetables, but are fondest of seeds; and tares, and the smallest kind of horse-beans, is the most suitable food both in point of economy and fattening qualities. Pease, wheat, buck-wheat, and even barley, oats, &c., are also eaten by pigeons, but old tares may be reckoned their very best food; new tares, pease, or beans, are reckoned scouring. Wherever pigeons are kept, the best way to keep them chiefly at home, and thereby both prevent their being lost, and their doing injury to corn-crops, is to feed them well: this is also the only way in which, in modern times, they will afford abundance of fat and delicate squabs for the table, which, well fed, they will do every month in the year, and thus afford a constant supply of delicate stimulating food. Pigeons are generally fed in the open air adjoining their cote or house; but in inclement weather, or to attach new pigeons to their home, both food and water should be given internally. That this may be done without waste, and without frequently disturbing the birds, two contrivances are in use; the first is the meat-box or hopper, from whence grain or pulse descends from the hopper as eaten out of a small shallow box; the next is the water-bottle, an ovate, long, naked bottle, reversed in a small basin to which it serves as a reservoir. Any bottle will do, but the pigeons are apt to alight on and dirty such as when reversed present a flat top.

6771. Pigeons being fond of salt, what is called a pigeon-cat is placed in the midst of the pigeon-house, or in the open air near it. It seems these birds are fond of salt and hot substances, and constantly swallow small stones to promote digestion. The salt-cat is thus composed; gravel or drift-sand, unctuous loam, the rubbish of an old wall, or lime, a gallon of each; should lime be substituted for rubbish, a less quantity of the former will suffice; one pound of cummin-seed, one handful of bay-salt; mix with stale urine. Inclose this in jars, corked or stopped, holes being punched in the sides, to admit the beaks of the pigeons. These may be placed abroad. They are very fond of this

mixture, and it prevents them from pecking the mortar from the roofs of their houses, which they are otherwise very apt to do.

6772. *Cleanliness* is one of the first and most important considerations: the want of it in a dove-cote will soon render the place a nuisance not to be approached, and the birds, both young and old, will be so covered with vermin, and besmeared with their own excrement, that they can enjoy no health or comfort, and mortality is often so induced. Mowbray's were cleaned daily, thoroughly once a week, a tub standing at hand for the reception of the dung, the floor covered with sifted gravel, often renewed.

6773. *Pigeon-houses* are of three kinds, small boarded cases fixed on posts, trees, or against the ends of houses: lofts fitted up with holes or nests; and detached buildings. The first are generally too small to contain a sufficient brood, and are also too subject to variations of temperature; and the last, on the other hand, are now-a-days too large, and therefore the most suitable for the farmer is a loft or tower rising from a building in which no noisy operation is carried on. The lofts of any of the farm-buildings at a distance from the threshing-machine are suitable, or a loft or tower over any detached building will answer well; but the best situation of all is a tower raised from the range of poultry-buildings, where there is such a range, as the pigeons can thus be more conveniently treated, and will feed very readily with domestic poultry. For a tower of this sort, the round form should be preferred to the square; because the rats cannot so easily come at them in the former as in the latter. It is also much more commodious; as, by means of a ladder turning round upon an axis, it is possible to visit all the nests in the house, without the least difficulty; which cannot be so easily done in a house of the square form. And in order to hinder rats from climbing up the outside of it, the wall should be covered with tin-plates to a certain height, as about a foot and a half; which should project out three or four inches at the top, to prevent their getting up more effectually. A common mode in France is to raise a boarded room on a strong post powerfully braced (*fig. 729.*), the interior sides of which are lined with boxes for the birds (*a*), and the exterior east and west sides with balconies, or sills for them to alight on and enter to their boxes (*b*). The north and south sides are lined with boxes inside, but without openings, as being too cold on the one front, and too warm on the other.

6774. *The interior of the pigeon-house* must be lined with nests or holes, subdivided either by stone, as in the ancient mural pigeon-houses; by boards; or each nest composed of a vase or vessel of earthenware fixed on its side. Horizontal shelves (*fig. 730.*), divided vertically at three feet distance, are generally esteemed preferable to

730



every other mode; the width of the shelf may be twenty inches, the height between shelf and shelf eighteen inches; and a slip of board three or four inches high is carried along the front of the partitions to keep in the nests. Sometimes, also, a partition of similar height is fixed in the middle of each three-foot division, which thus divides it into two nests. This, Mowbray and Girton concur in recommending as likely to prevent the young from running to the hen when sitting over fresh eggs, and perhaps occasioning her to cool and addle them; for when the young

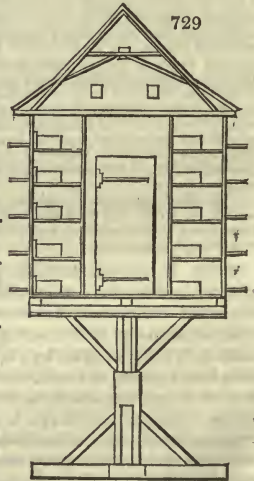

729

are about a fortnight or three weeks old, a good hen will leave them to the care of the cock, and lay again. Some prefer breeding-holes with no board in front, for the greater convenience of cleaning the nests; but as the squabs are apt to fall out by this practice, a good way would be to contrive the board in front to slip up and down in a groove, by which each nest might be cleaned at pleasure. As tame pigeons seldom take the trouble of making a nest, it is better to give them one of hay, to prevent the eggs from rolling. There are also straw buckets made in the form of nests, and also nests or pans of earthenware. Where pans are used, it is common to place a brick between them (two being placed in a breeding hole), for the cock and hen to alight on, but on the whole straw nests are best. The pigeon-house has two entrances, one a common sized door for man, either on the ground level, or to be ascended to by a ladder, as used formerly to be the case; and the other on a rising above the roof, and consisting of small holes three or four by twelve or fourteen inches for the entrance of the pigeons. A series of ranges of these are generally placed over each other, in a boarded front looking to the south, with a shelf to each range, and surrounded by a row of iron spikes to pro-

tect them from cats. The elevation of pigeon-houses (*fig. 731.*), as already described, are of endless variety.

6775. *The breeding holes* constitute the fixtures of the pigeon-house; its *utensils* are the hopper and bottle already described, (6770.) a barrel or box for food, a step-ladder to reach the nests, and some other articles not peculiar to this department of rural economy. The pigeon-trap for enticing and entrapping the pigeons of others, we do not describe.

6776. *Pigeons in new lodgings* are apt sometimes to forsake their habitations. Many nostrums have been recommended to prevent them from doing so; but if squabs be selected, cleanliness and security attended to, and a salt cot placed in or near the house, there will be little danger of this taking place. Fumigations with highly odoriferous drugs or even assafetida is also said to attract pigeons to a neglected dovecote, or attach them to a new one.

6777. *Diseases of pigeons.* Fancy pigeons, being many of them monstrous productions, are very subject to diseases. Girton enumerates upwards of a dozen with their cures, including the corruption of the egg in the uterus from over high feeding; a gorged crop from voracious feeding; insects from filthiness in the pigeon house, and the canker from cocks fighting with each other. Little can be done in the way of curing any of these diseases otherwise than by recurrence to the proper regimen; if this does not speedily take effect it is better to put the bird *hors de peine* both for humanity's sake and to prevent infection. Fortunately, the common pigeon reared for the table is little liable to diseases.

6778. *Laws respecting pigeons.* By the 1st of James, c. xxvii., shooting, or destroying pigeons by other means, on the evidence of two witnesses, is punishable by a fine of 20s. for every bird killed or taken, and by the 2d of Geo. III. c. xxix. the same offence may be proved by one witness, and the fine is 20s. to the prosecutor. Any lord of the manor or freeholder, may build a pigeon house upon his own land, but a tenant cannot do it without the lord's licence. Shooting or killing within a certain distance of the pigeon house, renders the person liable to pay a forfeiture.

6779. *The common pheasant* (*Phasianus colchicus, L.*), is a native of the old continent, but not of America, and has long been naturalised in the warmer and most woody counties of England. It is very common in France, and before the Revolution used to be a great nuisance to the farmers, even to the gates of Paris. The pheasant runs fast, but flies low and heavily; it crows not unlike the common cock, being of the same genus, and is supposed to live six or eight years. Pheasants are both granivorous and carnivorous; they feed upon all sorts of insects and vermin like the peacock, and are said to be greedy of toads, when not too large to swallow; whereas, according to report, they will not touch the frog, of which ducks are so fond. They are prized in park scenery for their beautiful plumage and showy figure, and as game for the delicacy of their flesh, which is of a high flavor and alkaline quality. It is in season in autumn, and most esteemed when under a year old, and very fat. Every gentleman who has a well-wooded, well enclosed park, and in whose woods are abundance of such evergreens as the spruce fir, holly, box, broom, &c., may stock it with pheasants; and he may preserve his stock if he will continue to supply them with abundance of food, and deter thieves, polecats, &c. The more common the pheasant becomes, the less will it be subjected to the attacks of those enemies.

6780. *Varieties.* Besides that which may be considered common or wild in this country, and which is generally of a brown color, there is the *gold* and *silver*, natives of China, and very hardy in this country, and good breeders. The ring-necks, natives of Tartary, bred in China, very scarce; their plumage very beautiful. The white and pied; both sorts will intermix readily with our common breed, as will the Bohemia, one of the most beautiful of its kind, and equally scarce. The golden variety is generally of the highest price, and the common most hardy, and of the largest size.

6781. *Breeding.* In a wild state the hen-pheasant lays from eighteen to twenty eggs in a season, but seldom more than ten in a state of confinement. As this bird has not hitherto been domesticated, and as the flesh of those brought up in the house is much inferior to that of the wild pheasant, they are chiefly bred for show, for replenishing a park, or for turning out in well enclosed reclusive scenes, which they will not readily leave if well fed, and not much disturbed. Hence every proprietor may naturalize them at least on a part of his grounds, say, for example, a wood with glades of pasture enclosed by a close paling or high wall. The natural nest of the pheasant is made on the ground, and composed of dry grass and leaves, which being provided for her in confinement, she will always arrange properly. They will breed freely with the common fowl, but as neither flesh nor form are improved by the cross, this is seldom resorted to.

6782. In *stocking a pheasantry*, the general mode is to procure eggs from some establishment of this sort or otherwise, and the following are the directions of Castang, as given in Mowbray's *Treatise on Poultry*. Eggs being provided, put them under a hen that has kept the nest three or four days; and if you

731

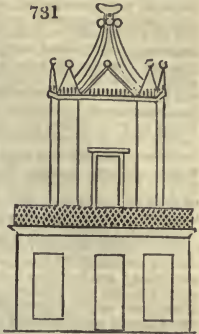

set two or three hens on the same day, you will have the advantage of shifting the good eggs. At the end of ten or twelve days, throw away those that are bad, and set the same hen or hens again, if setting hens should not be plenty. The hens having set their full time, such of the young pheasants as are already hatched, put into a basket, with a piece of flannel, till the hen has done hatching. The brood now come, put under a frame with a net over it, and a place for the hen, that she cannot get to the young pheasants, but that they may go to her: and feed them with boiled egg cut small, boiled milk and bread, alum curd, ants' eggs, a little of each sort, and often. After two or three days they will be acquainted with the call of the hen that hatched them, may have their liberty to run on the grass plot, or elsewhere, observing to shift them with the sun, and out of the cold winds; they need not have their liberty in the morning till the sun is up; and they must be shut in with the hen in good time in the evening. Every thing now going on properly, you must be very careful (in order to guard against the distemper to which they are liable) in your choice of a situation for breeding the birds up; and be less afraid of foxes, dogs, polecats, and all sorts of vermin, than the distemper. Castang had rather encounter all the former than the latter; for those with care may be prevented, but the distemper once got in is like the plague, and destroys all your hopes. What he means by a good situation is nothing more than a place where no poultry, pheasants, or turkeys, &c. have ever been kept; such as the warm side of a field, orchard, pleasure-ground, or garden, or even on a common, or a good green lane, under circumstances of this kind; or by a wood side; but then it is proper for a man to keep with them, under a temporary hovel, and to have two or three dogs chained at a proper distance, with a lamp or two at night. He has known a great number of pheasants bred up in this manner in the most exposed situations. It is proper for the man always to have a gun, that he may keep off the hawks, owls, jays, magpies, &c. The dogs and lamps shy the foxes more than any thing; and the dogs will give tongue for the man to be on his guard if smaller vermin are near, or when strollers make their appearance. The birds going on as before mentioned, should so continue till September, or (if very early bred), the middle of August. Before they begin to shift the long feathers in the tail, they are to be shut up in the basket with the hen regularly every night; and when they begin to shift their tail the birds are large, and begin to lie out, that is, they are not willing to come to be shut up in the basket: those that are intended to be turned out wild, should be taught to perch (a situation they have never been used to); this is done by tying a string to the hen's leg, and obliging her to sit in a tree all night: be sure you put her in the tree before sun-set; and if she falls down, you must persevere in putting her up again till she is contented with her situation; then the young birds will follow the hen, and perch with her. This being done, and the country now covered with corn, fruits, and shrubs, &c. they will shift for themselves. For such young pheasants as you make choice of for your breeding-stock at home, and likewise to turn out in spring following, provide a new piece of ground, large and roomy for two pens, where no pheasants, &c. have been kept, and there put your young birds in as they begin to shift their tails. Such of them as you intend to turn out at a future time, or in another place, put into one pen netted over, and leave their wings as they are; and those you wish to keep for breeding put into the other pen, cutting one wing of each bird. The gold and silver pheasants you must pen earlier, or they will be off. Cut the wing often; and when first penned feed all your young birds with barley-meal, dough, corn, and plenty of green turnips.

6783. *A receipt to make alum curd.* Take new milk, as much as your young birds require, and boil it with a lump of alum, so as not to make the curd hard and tough, but custard like. Give a little of this curd twice a day; and ants' eggs after every time they have had a sufficient quantity of the other food. If they do not eat heartily, give them some ants' eggs to create an appetite, but by no means in such abundance as to be considered their food. The distemper alluded to above, is not improbably of the same nature as the roup in chickens, contagious, and dependent on the state of the weather; and for prevention requiring similar precautions. When a pheasant is connected with a piece of ground covered with bushes or shrubbery, the birds may be bred in houses or pens, and afterwards put out into small enclosures, say one hundred feet square, with fences twelve feet high, each containing abundance of low evergreens, especially the spruce fir, and an artificial or natural supply of water. Under such an arrangement the hen pheasant will hatch her own eggs, and the following directions are given as to attendance by the same experienced person. Not more than four hens to be allowed in the pens to one cock. And in the out covers, three hens to one cock may be sufficient, with the view of allowing for accidents, such as the loss of a cock or hen. Never put more eggs under a hen than she can well and closely cover, the eggs fresh and carefully preserved. Short broods to be joined and shifted to one hen: common hen pheasants in close pens, and with plenty of cover, will sometimes make their nests and hatch their own eggs; but they seldom succeed in rearing their brood, being so naturally shy; whence should this method be desired, they must be left entirely to themselves, as they feel alarm even in being looked at. Eggs for setting are generally ready in April. Period of incubation the same in the pheasant as in the common hen. Pheasants, like the pea-fowl, will clear grounds of insects and reptiles, but will spoil all wall-trees within their reach, by picking off every bud and leaf.

6784. *Feeding.* Strict cleanliness to be observed, the meat not to be tainted with dung, and the water to be pure and often renewed. Ants' eggs being scarce, hog-lice, ear-wigs, or any insect may be given; or artificial ants' eggs substituted, composed of flour beaten up with an egg and shell together, the pellets rubbed between the fingers to the proper size. After the first three weeks, in a scarcity of ants' eggs, Castang gives a few gentles, procured from a good liver tied up, the gentles, when ready, dropping into a pan or box of bran; to be given sparingly, and not considered as common food. Food for grown pheasants, barley or wheat; generally the same as for other poultry. In a cold spring hemp seed, or other warming seeds are comfortable, and will forward the breeding stock.

6785. *In keeping fancy pheasants,* as the gold, silver, or other breeds, the best mode is to enclose a few poles of ground containing trees and bushes with a well painted copper netting, and in some concealed part to have a house or lodge for supplying water and food. This forms by far the most elegant aviary, and is the only one that at all times appears clean. They will thrive very well, however, in an aviary on the common construction.

6786. *The partridge* (*Tetrao perdix*, fig. 732.) is a native of all the temperate regions of Europe, but unable to sustain rigorous cold, or intense heat. Partridges are highly valued as food on most parts of the continent, and as a table luxury in England. In the Ukraine both partridges and pheasants are more abundant than any where else in Europe: they were formerly so common in France, that Rozier informs us it was necessary to sow three or four times the corn that was necessary to raise a crop, and that even this had often to be done three or four times in a season. The

732





bird feeds like the pheasant on insects and seeds, and is particularly fond of those of the wild mustard. It has not been domesticated, but may be hatched and reared in the same manner as the pheasant.

6787. *The quail (Tetrao coturnix, fig. 733.)* is a native of the East, and abounds in Egypt, as appears from the supplies the Israelites obtained while in the wilderness, and also in the islands of the Archipelago, and in Italy. They migrate from warmer to colder regions. They are naturalized and breed in England, changing their residence within it on the approach of winter from the more exposed to the more temperate districts. They are very abundant in France, and are caught in snares and nets (described by Rozier), and sent both to the Paris and London markets. The bird was proverbial among the Romans



as captious and quarrelsome, and is employed among the Chinese for the same amusement as game cocks are in England. Here it is not domesticated, but may be reared and preserved in the same manner as the pheasant and partridge, and its food is nearly the same as that of the latter bird.

6788. *The red grouse, or moor cock, (Tetrao scoticus, fig. 734.)* is an esteemed variety of gallinacea, pursued with avidity by sportsmen in the mountainous districts of England, Wales, and Scotland, in which latter it abounds, there feeding in plenty among the heather, its favorite food. Its beautiful plumage, and its exquisite flavor, render it an object of considerable interest.



6789. *The black grouse, or black cock, (Tetrao tetrix, fig. 735.)* is less common than the red grouse, and is therefore more highly prized. It is also larger, weighing nearly four pounds. Its plumage is a rich mixture of black with blue; relieved by marking of white. Its legs are also covered with very fine minute feathers: and it draws a peculiar characteristic from the curvilinear form of the tail, which branches out at the end into two crooked expansions.



6790. *The wood grouse, or cock of the wood, (Tetrao urogallus, fig. 736.)* is, after the bustard, the largest bird

among those we call game; it being little less than a turkey. It was originally common in the mountainous parts of Britain; but is now nearly if not wholly extinct with us; though still common in the northern parts of Europe, where it lives in pine forests, on the cones of which it is supposed to subsist; and which at some seasons gives its flesh a terebinthinated taste: at other times it is delicious eating, and is often sent to England frozen. Like the other grouse he has the scarlet patch on his head, his legs are defended in the same manner by a feathered covering, and his whole markings are equally varied and beautiful. From the richness of the plumage, in all the varieties of the tetrao, and from the extreme delicacy of their flesh as an article of food, it is to be lamented that attempts are not made to domesticate them in addition to our other poultry. It is thought by observant sportsmen, and scientific naturalists, that this might be attended with less difficulty than the domesticating the partridge and pheasant: and the attempt is recommended to the patriotic amateur.

736



6791. *The lark (Alauda arvensis, L.)* and other birds were reared and fattened by the Romans for the table. The lark is caught by nets and other means in some of the open districts of England, as about Dunstable, Cambridge, &c., and brought to market for the table, as are various other birds by a particular class of men known as bird-catchers. It is an idle uncertain kind of life not to be recommended.

6792. *Of singing birds,* a great variety are domesticated; and their breeding and rearing forms a very peculiar and curious branch of rural economy. Not only all the birds which please by their natural song are domesticated and kept in cages; as the canary, nightingale, lark, linnet, finch, thrush, &c., but even some which do not sing in a wild state, as the sparrow, hammer, &c., are by art taught the notes of other birds.

6793. *Wild singing birds* are caught by various devices, according to the species of bird, and season of the year. The pairing season in spring, generally March and April, is on the whole the best season, and the common means are a net called a clap trap, a

6803. The *tench* (*Cyprinus tinca*, L., *b*) inhabits almost every where in stagnant waters; grows quickly, and reaches from four to eight pounds weight; is very fertile and tenacious of life, and will live all the winter under the ice; feeds on worms and water plants; is very foolish, and may be easily caught; body covered with a thick mucus, and small scales which adhere firmly to the skin, above dark-green, the sides above the line green, beneath yellow, belly white; varies in its colors by age, sex, or the waters it inhabits; flesh white, soft, and well tasted.

6804. In *stocking with tench* the number per acre may be more than of carp. In Berkshire, where there are many ponds for the preserving of fish, they usually stock with tench or carp in the proportion of one hundred to the acre, the fish remaining four years in them. But in the management of Sir Harry Featherstone, in Sussex, in a pond of twenty acres reduced to sixteen by the deposition of mud, the stock is generally in the proportion of twelve hundred carp and an equal number of tench; or at the rate of seventy-five brace to the acre. And in this proportion they are said to succeed well.

6805. The *gudgeon* (*Cyprinus gobicus*, L., *c*) is a very inferior fish to the carp or tench, but being of easy culture and rapid increase, is kept in many places as food for pike and perch. It inhabits gentle streams and lakes of Northern Europe; is tenacious of life, and very fertile; about eight inches long; feeds on herbs, worms, insects, the fry of other fish, and parts of carcases; body narrow, spotted, above livid, the sides above the line blue, beneath whitish yellow, but it varies its colors by age, the different waters it inhabits, and its food; flesh white, and very grateful.

6806. The *perch* (*Perca fluviatilis*, L., *d*) is an excellent fish, and though naturally found in streams in Europe and Siberia, yet will live in large ponds or lakes, provided the water be clear. It grows to two feet long; back and part of the sides deep green, with five broad black bars, which are sometimes dark-green or blue, and very rarely wanting; belly white, tinged with red; swims with great swiftness and at a certain height in the water; is tenacious of life, but eagerly takes a bait; feeds on aquatic insects and smaller fish; spawns in May and June, and is very prolific; it has no real air-bladder, and from its integuments may be obtained a kind of glue; flesh very delicate.

6807. In *stocking with perch*, as they are great breeders, six hundred to the acre may be sufficient.

6808. The *pike* (*Esox lucius*, L., *e*) inhabits most lakes of Europe, Lapland, Northern Persia, and North America, and is found even in the Caspian Sea; swims, and grows very rapidly, one to eight feet long; is extremely voracious and long-lived; feeds on almost any thing which comes in its way, even its own tribe; spawns from February to April; body above black, the sides cineraceous spotted with yellow, beneath white dotted with black; rarely orange spotted with black or green; scales small, oblong, hard. The pike is best reared in deep ponds by itself, in which some gudgeon may be put to breed for its food. It will thrive in waters, partaking of the chalybeate quality, in which few other fish would live.

6809. The *gold fish* (*Cyprinus auratus*, L.) is an inhabitant of the rivers of China and Japan, and is naturalized almost every where on account of its elegance and vivacity; the colors vary greatly, but are naturally and mostly of a most splendid golden hue; scales large. It is bred in small ponds in gardens near London and Paris for sale, as an ornamental inhabitant of crystal vases, or garden basins of water.

6810. The *minnow* (*Cyprinus phoxinus*, L., *f*), the *dace* (*C. lentiscus*, L.), and the *roach* (*C. rutilus*, L.), are very small fish, which abound, the first in gravelly streams, and the others in still waters; both are useful as affording food to other fish, and may therefore be put into fish ponds. They are also very good to eat.

6811. Of the *trout and salmon family*, there are several species, as the lake trout, gilt and red charr, which inhabit Alpine lakes in northern countries, and might probably be introduced with advantage in the lakes of Cumberland, Westmoreland, and the Highlands of Scotland. The red charr is caught in Keswick lake. The salmon and salmon-trout (*Salmo salar*, and *S. trutta*), require salt water and a river; and the fresh water trout (*S. fario*), requires too rapid a stream for art to imitate; they succeed, however, to a certain extent, in very slow running waters which are clear.

6812. The *eel* (*Muræna anguilla*, L.) inhabits almost every where in fresh waters; grows sometimes to the length of six feet, and weighs twenty pounds; in its appearance and habits something resembles the serpent tribe; during the night quits its element, and wanders along meadows in search of snails and worms; beds itself deep in the mud in winter, and continues in a state of rest; is very impatient of cold, and tenacious of life; the flesh of such as frequent running water is very good; is viviparous, and has 116 vertebræ. One advantage of the eel is, that it will thrive in muddy ponds of very small size, where no other fish would live.

6813. On the *subject of cultivating fishes* it may be observed, that the waters of some ponds are better adapted for raising some sorts of fish than others. Thus, those where the water is rich and white are more adapted for carp; while such as have a thicker appearance, and where there is a greater deposition of muddy matter, are better suited to tench. Perch are capable of being raised in almost any sort of ponds. Eels succeed best where the ponds are not very large, but where fed by a spring, and there is a large portion of rich

sediment. Pike should never be kept in ponds with carp or tench, but in separate breeding-ponds, where the supplies of small fry are considerable and not wanted for stores. Carp, tench, and perch are the sorts principally cultivated with a view to profit, with a few eels occasionally. But perch and eels should not be admitted where the ponds are but thinly stocked, as they are great devourers of the young fish. Carp and tench answer best together where the extents of the ponds are pretty large, as, in other cases, the former, from being a much more powerful fish, beats and deprives the latter of his food. Carp seldom afford much profit in ponds of less extent than half an acre; but tench thrive well in those of almost every size, being often found good in ponds of only a few perches square. Carp, perch, and eels succeed well together; and also tench and eels. Carp more frequently injure themselves by breeding than tench, though it sometimes happens with the latter. It is not improbable, but that in small ponds it may be the best practice to keep the carp and tench separate. The produce or profit afforded by fish-ponds has not yet, perhaps, been sufficiently attended to in different situations to afford correct conclusions; nor is it well ascertained what is the annual increase in weight in fish of different kinds, in different periods of their growth, and under different circumstances of soil and water. Loveden (*Annals of Agriculture*) states, that in Berkshire a pond of three acres and a half, drawn after being stocked three years with stores of one year old, produced of carp, 195 lb. weight, of tench 230 ditto; together 425 lb., which sold for 20*l.* 10*s.* or nearly 2*l.* 6*s.* per acre per annum.

6814. *The taking of cultivated fish* is generally done with nets, and sometimes by emptying the pond of water. Whatever way is adopted, only those fit to be used are taken, and the rest returned to grow larger. No fish is taken, or fit to be used, for a month before and after the spawning season, which with most fresh water fish is in April, May, or June. The Marquis de Chabanes proposes to catch fish, both in fresh and salt water, by immersing a burning lamp in an air box with mirrors, and round which he has traps into which the animals are to be entangled, while approaching the light and the multiplied images of their own species. For this contrivance he has taken out a patent. Salmon are sometimes caught by torch light.

6815. *The castration of fish* has been successfully practised both in this and other countries, and both with the male and female. Castrated fish attain to a larger size, and are in season at the end of the year. The mode of performing the operation is described in Rees's *Cyclopædia*, art. *Fish, Castration of*; and in the *Philosophical Transactions*, vol. 48. part ii. p. 106.

6816. *Of the amphibeæ* which are or may be cultivated for food or ornament, the principal are the frog and tortoise.

6817. *The esculent frog* (*Rana esculenta*, L., fig. 741 a), though generally despised in this country, is yet an excellent article to those who are accustomed to it; and there are few Englishmen who have eaten a fricassé of the thighs of this animal in France or Italy, but what would wish to do so again. The body of this frog is green, with three yellow lines, the middle ones extending from the mouth to the anus, with the angles of the mouth distended in a globular form; the male makes a continual croaking in an evening, especially before rain; when irritated will pursue and destroy a pike. It is rare in England, but very common on the continent, where it is in season for the table in June.

6818. *The tree frog* (*Rana arborea*, L., b), is green above, and whitish beneath, with a yellow curved line on the side. In elegance and activity it is superior to every other European species. In summer it resides in the woods, and haunts the trees in quest of insects, which it approaches on its belly, in the same manner as a cat to a mouse, and at length seizes with an elastic and instantaneous spring. It is particularly noisy on the approach of rain. In winter it takes up its abode in the bottom of the waters, remaining till the spring in a state of torpor. The noise of this frog is by many considered musical, and it is often kept in gardens in Germany both as a curiosity and as a weather guide. It certainly deserves introduction to this country.

6819. *There are two species of tortoise* which might be cultivated: the common, and the mud tortoise. The common tortoise (*Testudo græca*, L., fig. 742 a) weighs three pounds, and the length of its shell about seven inches. It abounds in the countries surrounding the Mediterranean, and particularly in Greece, where the inhabitants not only eat its flesh and eggs, but frequently swallow its warm blood. In Sep-



tember or October it conceals itself, remaining torpid till February, when it re-appears. In June it lays its eggs, in holes exposed to the full beams of the sun, by which they are matured. Tortoises attain most extraordinary longevity, and one was ascertained to have lived in the gardens of Lambeth to the age of nearly one hundred and twenty years. It will answer the purpose of a barometer, and uniformly indicates the fall of rain before night, when it takes its food with great rapidity, and walks with a sort of mincing and elate step. It appears to dislike rain with extreme aversion, and is discomfited and driven back only by a few and scarcely perceivable drops.

742



6820. *The mud tortoise* (*T. lutaria*, *b*), is common both in Europe and Asia, and particularly in France, where it is much used for food. It is seven inches long; lays its eggs on the ground, though an aquatic animal; walks quicker than the land tortoise; and is often kept in gardens, to clear them from snails and various wingless insects. In fish ponds it is very destructive, biting the fishes, and, when they are exhausted by the loss of blood, dragging them to the bottom and devouring them. The tortoise may be fed on any vegetable refuse, milk, worms, offal, or almost any thing. Linnæus says they are in all things extremely slow, and in copulation frequently adhere together a month, and live several days after the head is cut off. (*Shaw's Zoology.*)

they are exhausted by the loss of blood, dragging them to the bottom and devouring them. The tortoise may be fed on any vegetable refuse, milk, worms, offal, or almost any thing. Linnæus says they are in all things extremely slow, and in copulation frequently adhere together a month, and live several days after the head is cut off. (*Shaw's Zoology.*)

---

## CHAP. XI.

### *Of Insects and Worms which are or may be subjected to Culture.*

6821. *The insects* we mean to notice here are the silk moth, bee, and craw fish; and the worms, the leech and snail.

6822. *The silk worm or moth* (*Phalena mori*, *L.*, *fig. 56.*) is a native of China, and was introduced into Europe in the reign of the Emperor Justinian, A.D. 160. It is a whitish moth, with a broad pale brown bar across each of the upper wings. The caterpillar or larva, emphatically known by the title of the silk worm, is, when full grown, nearly three inches long, and of a yellowish grey color: on the upper part of the last joint of the body is a horn-like process, as in many of the sphinges. It feeds, as every one knows, on the leaves of the white mulberry, in defect of which may be substituted the black mulberry, and even in some instances the lettuce, and a few other plants. The silk worm remains in its larva state about six weeks, changing its skin four times during that period, and, like other caterpillars, abstaining from food for some time before each change. When full grown, the animal entirely ceases to feed, and begins to form itself a loose envelopment of silken fibres in some convenient spot which it has chosen for that purpose, and afterwards proceeds to enwrap itself in a much closer covering, forming an oval yellow silken case or ball about the size of a pigeon's egg, in which it changes to a chrysalis, and after lying thus enclosed for the space of about fifteen days, gives birth to the moth. This, however, is always carefully prevented when the animals are reared for the purposes of commerce; the moth greatly injuring the silk of the ball, by discharging a quantity of colored fluid before it leaves the cell; the silk balls are, therefore, exposed to such a degree of heat as to kill the inclosed chrysalides, a few only being saved for the breed of the following year. The moth, when hatched is a very short-lived animal, breeding soon after its exclusion, and when the females have laid their eggs, they, as well as the males, survive but a very short time.

6823. *The culture of silk* varies but little in different countries; it does not require any great degree of skill, or a great capital; and it is well known that the silk worm with proper care, will breed and thrive very well in England. Though the price of labor is too high in this country to render this a profitable branch of rural economy, yet as it is carried on by some as matter of recreation, and may be useful in various ways, we shall describe the process.

6824. *The culture and treatment of the mulberry* is abundantly simple, and has been given in noticing the silk culture of France and Italy. It is a mistake of various

writers to assert that grafting is necessary; on the contrary, grafted mulberry trees are held in France to be later in exfoliating and shorter lived than seedlings. (*Cours d'Agr. &c.*, art. *Murier*.)

6825. *The produce of the worms or cocoons*, as soon as completed, are either reeled off, or, in the silk countries, sold to others, who make this a distinct trade. The silk, as formed by the worm, is so very fine, that if each ball, or cocoon, was reeled separately, it would be totally unfit for the purposes of the manufacturer; in the reeling, therefore, the ends of several cocoons are joined and reeled together out of warm water, which, softening their natural gum, makes them stick together, so as to form one strong smooth thread. As often as the thread of any single cocoon breaks, or comes to an end, its place is supplied by a new one, so that by continually keeping up the same number, the united thread may be wound to any length: the single threads of the newly added cocoons are not joined by any tie, but simply laid on the main thread, to which they adhere by their gum; and their ends are so fine as not to occasion the least perceptible unevenness in the place where they are laid on. The apparatus for reeling consists merely of a small open kettle of water, under which is a fire to keep it hot, and a reel of a very simple construction. Care should be taken in the operation, that the silk when reeled off may consist of a smooth thread of equal thickness and strength, not flat, but of a round form, having the small threads of which it is composed as equally stretched and firmly united as possible; and that the several rounds as they lie on the reel, should not be glued together. When the skain is quite dry it is taken off the reel, and a tie is made with some of the refuse silk on that part of the skain where it bore upon the bars of the reel, and another tie on the opposite part of the skain, after which it is doubled into a hank, and usually tied round near each extremity, when it is laid by for use or sale. In this state, in which all the silk that is brought from India, and considerable part of what comes from Italy and other parts, arrives, it is called raw silk; the principal part of it is afterwards sent to a mill to be thrown; that is, to have two ends of it doubled and twisted together, by which it is converted into tram, or organzine, according to the fineness of the silk, and the purposes to which it is intended to be applied in the manufacture.

6826. *The culture of silk in England* has been attempted at various periods from the time of James I., in 1608, to the present. A silk garden was established near St. James's Palace in 1629, and another at Chelsea in 1718. As the mulberry tree is scarce in some parts of this country, attempts have been made to feed the worms on other plants. Miss Croft, of York, in 1792, sent to the Society for the Encouragement of Arts, Manufactures, and Commerce, a specimen of silk produced by worms fed entirely upon lettuce leaves. This society continue to offer premiums for the production of silk in this country; and a company is now establishing, for giving it a complete trial, in several districts both of Britain and Ireland.

6827. *The common honey bee (Apis mellifica, L.)* inhabits Europe in hollow trees, but is chiefly kept in hives, being domesticated every where. Perhaps more has been written on the economy of this insect, than on any other animal employed in agriculture; and certainly to very little purpose. After all that has been done in England, France, and Italy, the bee is still more successfully cultivated, and finer honey produced, in Poland, by persons who never saw a book on the subject, or heard of the mode of depriving bees of their honey without taking their lives. Much as has been written in France and England on this last part of the subject, it is still found the best mode to destroy the hive in taking the honey. Unanswerable reasons for this practice, are given by La Grenée, a French apiarian, which are elsewhere quoted by us at length, (*Encyc. of Gard.* art. *Bees*), and allowed to be conclusive as to profit, even by Huish. The honey produced by any hive or apiary, depends much more on the season, and the quantity and kind of flowers with which the neighborhood abounds, than on the form of hive, or artificial management. Viewing the subject in this light we shall avoid noticing the mode of operating with glass, storying, cellular, or other curious hives of recent invention; and treat only of the simplest methods. The author we shall follow is Howison.

6828. *The apiary* or place where the bee-hives are placed should in very warm situations be made to face the east; and in colder districts the south-east. It should be well protected from high winds, which not only prevent the bees from leaving the hive in quest of honey, but they also surprise them in the fields, and often kill them by dashing them against the trees and rocks, or into rivers. The hives in an apiary should always be placed in a right line; but should the number of the hives be great, and the situation not capacious enough to admit of their being placed longitudinally, it is more advisable to place them over one another, on shelves, (*fig. 357.*) than in double rows on the ground. A bee, on leaving the hive, generally forms an angle of about forty five with the horizon; the elevation of the hive should, therefore, be about two feet from the ground, in order to

protect it from humidity. The greater the elevation of the hive, the longer is the flight of the swarm; and when they are at a certain point of elevation, the swarms are lost for ever to the proprietor. If the hives are to be placed in a double row, the hinder ones should alternate with, and be placed at such a distance from the front ones, that when the bees take their flight, no obstruction is offered to their ascent. Huish recommends placing every hive upon a single pedestal, and at two or three feet distance from each other. By this means when any thing happens to one hive, the others are less likely to be disturbed than when placed on a shelf in a bee house; and the hive may be chained down and locked (fig. 743.) It is usual to have three or four legs or supports to the bee boards, but those who have tried one will never resort to more, as one is a much better protection from vermin and insects. The space in front of the apiary should be kept clear of high plants for two or three yards.

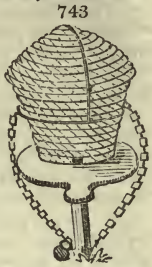

6829. The *variety of bees* employed is a matter of some consequence. To the common observer, all working bees, as to external appearance, are nearly the same; but to those who examine them with attention, the difference in size is very distinguishable; and they are, in their vicious and gentle, indolent and active natures, essentially different. Of the stock which Howison had in 1810, it required 250 to weigh an ounce; but they were so vicious and lazy, that he changed it for a smaller variety, which possesses much better dispositions, and of which it requires 296, on an average, to weigh an ounce. Whether size and disposition are invariably connected, he has not yet had sufficient experience to determine.

6830. The *best material and form* for hives is a straw thimble or flower-pot placed in an inverted position. Hives made of straw, as now in use, have a great advantage over those made of wood and other materials, from the effectual defence they afford against the extremes of heat in summer, and cold in winter.

6831. The *size of hives* should correspond as nearly as possible with that of the swarms. This has not had that attention paid to it which the subject demands, as much of the success in the management of the bees depends on that circumstance. From blind instinct, bees endeavor to fill with combs whatever hive they are put into, before they begin to gather honey. Owing to this, when the hive is too large for its inhabitants, the time for collecting their winter store is spent in unprofitable labor: and starvation is the consequence. This evil also extends to occasioning late swarming the next summer; it being long before the hive becomes so filled with young bees as to produce a necessity for emigration, from which cause the season is too far advanced for the young colonies to procure a winter stock. A full sized straw hive will hold three pecks, a small sized from one and a half to two pecks.

6832. The *Polish hive*, (*Pasieka Pol.*, fig. 744.) appears to us to be the second in merits to that described, and perhaps it may deserve the preference, if the mode of using it were generally known. It is simply the

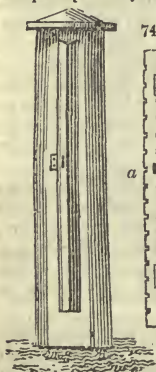

trunk of a tree, of a foot or fourteen inches in diameter and about nine feet long. It is scooped out (boring in this country would be better) for about six feet from one end, so as to form a hollow cylinder of that length, and of six or eight inches diameter within. Part of the circumference of this cylinder is cut out during the greater part of its length, about four inches wide, and a slip of wood is made to fit the opening. On the sides of this slip or segment (a) notches are made every two or three inches, of sufficient size to allow a single bee to pass. This slip may be furnished with hinges and with a lock and key; but in Poland it is merely fastened in by a wedge. All that is wanting to complete the hive is a cover at top to throw off the rain, and then it requires only to be placed upright like a strong post in the garden, so as the bottom of the hollow cylinder may be not nearer the ground than two feet, and the opening slip look to the south. When a swarm is to be put in, the tree, with the door or slip opened, is placed obliquely over it; when the bees enter, the door is closed, and the holes stopped with clay till the hive is planted or placed upright. When honey is wanted, the door is opened during the finest part of a warm day, when most of the bees are out; its entire state is seen from top to bottom, and the operator, with a sear in his mouth, or with a lighted rag, to keep off the bees from his hands, cuts out with a crooked knife, as much comb as he thinks fit. In this way fresh honey is obtained during the summer, the bees are never cramped for room, nor does it become necessary to kill them. The old comb, however, is annually cut out to prevent or lessen the tendency to swarming, which, notwithstanding this and the size of their dwelling, they generally do once a year; for the laws of nature are not to be changed. Though it be a fact, that a small swarm of bees will not do well in a large hive, yet if the hive extend in length and not in breadth, it is admitted both by Huber and Huish, that they will thrive in it. "If too great a diameter," says Huber, "be not given to the abode of the bee, it may without danger be increased in the elevation; their success in the hollow trees, their natural domicile, incontestibly proves the truth of this assertion"

6833. The *feeding of bees* is generally deferred till winter or spring, but this is a most erroneous practice. Hives should be examined in the course of the month of September or about the time of killing the drones, and if a large hive does not weigh thirty pounds, it will be necessary to allow it half a pound of honey, or the same quantity of soft sugar, made into syrup, for every pound that is deficient of that weight; and, in

like proportion, to smaller hives. This work must not be delayed, that time may be given for the bees to make the deposit in their empty cells before they are rendered torpid by the cold. Sugar simply dissolved in water (which is a common practice), and sugar boiled with water into a syrup, form compounds very differently suited for the winter store of bees. When the former is wanted for their immediate nourishment, as in spring, it will answer equally as a syrup: but if to be laid up as store, the heat of the hive quickly evaporating the water, leaves the sugar in dry crystals, not to be acted upon by the trunks of the bees. Hives may be killed with hunger, while some pounds weight of sugar remain in this state in their cells. The boiling of sugar into syrup forms a closer combination with the water, by which it is prevented from flying off, and a consistence resembling that of honey, retained. Howison has had frequent experience of hives not containing a pound of honey, preserved in perfect health through the winter, with sugar so prepared, when given in proper time, and in sufficient quantity.

6834. *To protect hives from the cold*, they are covered with straw or rushes, about the end of September, or later, according to the climate and season. This is an essential business, as well covered hives always prosper better the following season than such as have not been covered. In October, the aperture at which the bees enter should generally be narrowed, so as only one bee may pass at a time. Indeed, as a very small portion of air is necessary for bees in their torpid state, it were better, during severe frosts, to be entirely shut up, as numbers of them are often lost from being enticed to quit the hive by the sunshine of a winter day. It will, however, be proper at times to remove, by a crooked wire, or similar instrument, the dead bees and other filth, which the living at this season are unable to perform of themselves. To hives, whose stock of honey was sufficient for their maintenance, or those to which a proper quantity of sugar had been given for that purpose, no further attention will be necessary until the breeding season arrives. This, in warm situations, generally takes place about the beginning of May, and in cold, about a month after. The young bees, for a short time previous to their leaving their cells, and some after, require being fed with the same regularity that young birds are by their parents; and if the store in the hive be exhausted, and the weather such as not to admit of the working bees going abroad to collect food in sufficient quantity for themselves and their brood, the powerful principle of affection for their young compels them to part with what is not enough for their support, at the expence of their own lives. To prevent such accidents, it is advisable, if, during the breeding season, it rain for two successive days, to feed all the bees indiscriminately, as it would be difficult to ascertain those only who require it.

6835. *The swarming of bees* generally commences in June, some seasons earlier, and in cold climates or seasons later. The first swarming is so long preceded by the appearance of drones, and hanging out of working bees, that if the time of their leaving the hive is not observed, it must be owing to want of care. The signs of the second are, however, more equivocal, the most certain being that of the queen, a day or two before swarming, at intervals of a few minutes, giving out a sound a good deal resembling that of a cricket. It frequently happens that the swarm will leave the old hive, and return again several times, which is always owing to the queen not having accompanied them, or from having dropt on the ground, being too young to fly to a distance. Gooseberry, currant, or other low bushes, should be planted at a short distance from the hives, for the bees to swarm upon, otherwise they are apt to fly away; by attending to this, Howison has not lost a swarm by straying for several years. When a hive yields more than two swarms, these should uniformly be joined to others that are weak, as from the lateness of the season, and deficiency in number, they will otherwise perish. This junction is easily formed, by inverting at night the hive in which they are, and placing over it the one you intend them to enter. They soon ascend, and apparently with no opposition from the former possessors. Should the weather, for some days after swarming, be unfavorable for the bees going out, they must be fed with care until it clears up, otherwise the young swarm will run a great risk of dying.

6836. *The honey may be taken* from hives of the common construction, by three modes, partial deprivation, total deprivation, and suffocation.

6837. *Partial deprivation* is performed about the beginning of September. Having ascertained the weight of the hive, and consequently the quantity of honey-comb which is to be extracted, begin the operation as soon as evening sets in, by inverting the full hive, and placing an empty one over it; particular care must be taken that the two hives are of the same diameter, for if they differ in their dimensions, it will not be possible to effect the driving of the bees. The hives being placed on each other, a sheet or large table-cloth must be tied round them at their point of junction, in order to prevent the bees from molesting the operator. The hives being thus arranged, beat the sides gently with a stick or the hand, but particular caution must be used to beat it on those parts to which the combs are attached, and which will be found parallel with the entrance of the hive. The ascent of the bees into the upper hive will be known by a loud humming noise, indicative of the pleasure in finding an asylum from their enemy; in a few minutes the whole community will have ascended, and the hive with the bees in it may be placed upon the pedestal from which the full hive was removed. The hive, from which the bees have been driven, must then be taken into the house, and the operation of cutting out the honey-comb commenced. Having extracted the requisite quantity of comb, this opportunity must be embraced of inspecting the

hive, and of cleaning it from any noxious matter. In cutting the combs, however, particular attention should be paid not to cut into two or three combs at once, but having commenced the cutting of one, to pursue it to the top of the hive; and this caution is necessary for two reasons. If you begin the cutting of two or three combs at one time, were you to extract the whole of them, you would perhaps take too much; and secondly, to stop in the middle of a comb, would be attended with very pernicious consequences, as the honey would drop from the cells which have been cut in two, and then the bees, on being returned to their native hive, might be drowned in their own sweets. The bees, also, in their return to their natural domicile, being still under the impression of fear, would not give so much attention to the honey which flows from the divided cells; and as it would fall on the board, and from that on the ground, the bees belonging to the other hives would immediately scent the wasted treasure, and a general attack on the deprived hive might be dreaded. The deprivation of the honey-comb being affected, the hive may be returned to its former position, and reversing the hive which contains the bees, and placing the deprived hive over it, they may be left in that situation till the morning, when the bees will be found to have taken possession of their native hive, and if the season proves fine, may replenish what they have lost. (*Huish's Treatise on Bees.*)

6838. *Total deprivation* is effected in the same manner, but earlier in the season, immediately after the first swarm; and the bees, instead of being returned to a remnant of honey in their old hive, remain in the new empty one; which they will sometimes, though rarely, fill with comb. By this mode, it is to be observed, very little honey is obtained, the bees in June and July being occupied chiefly in breeding, and one, if not two, swarms are lost.

6839. *Suffocation* is performed when the season of flowers begins to decline, and generally in October. The smoke of paper, or linen rag soaked and smeared with melted sulphur, is introduced to the hive by placing it in a hole in the ground, where a few shreds of these articles are undergoing a smothering combustion; or the full hive may be placed on an empty one, inverted as in partial deprivation, and the sulphurous smoke introduced by a fumigating bellows, &c. The bees will fall from the upper to the lower hive in a few minutes, when they may be removed and buried, to prevent resuscitation. Such a death seems one of the easiest, both to the insects themselves, and to human feelings. Indeed, the mere deprivation of life to animals, not endowed with sentiment or reflection, is reduced to the precise pain of the moment, without reference to the past or the future; and as each pulsation of this pain increases in effect on the one hand, so on the other, the susceptibility of feeling it diminishes. Civilized man is the only animal to whom death has terrors, and hence the origin of that false humanity, which condemns the killing of bees in order to obtain their honey; but which might, with as much justice, be applied to the destruction of almost any other animal used in domestic economy, as fowls, game, fish, cattle, &c.

6840. On the *produce and profit* of bees much has been said by the patriotic apiarists. Both, however, are extremely uncertain; and as to the profit, it can never be great, while there is the competition of all Europe to contend with as to honey and wax, and no great demand for swarms. Bees, however, are interesting creatures, are supported at almost no expense; and a hive or two is therefore very desirable in the garden of every farmer and cottager.

6841. *The craw or cray fish* (*Cancer astacus*, L. fig. 745.), is a native of Britain, inhabiting still rivers and marshes, and lodging itself in holes made in the clayey banks.

The flesh is of an excellent flavor, and very nutritious, and has been recommended to persons under atrophies. There are various methods of preparing these animals: they may be either boiled or fried, and then taken out of their shells and made up in a variety of dishes. Preparations and broths of crayfish have been celebrated not only for a palatable aliment, but also for answering some medicinal intentions, as being of a moistening quality, and correcting acrimony. The delicate flavor of these fish depends in a great measure on their food.

When they have well-tasted food, their flesh preserves the relish of it; but when they feed on other things, they are often rendered of no value, by the flavor communicated to their flesh by them. It has been found that where the *Acorus calumnus* abounds, they feed on the roots of this plant, which renders their flesh so bitter as to be uneatable. They are very greedy of flesh, and flock in great numbers about carcasses thrown into the water where they are, and never leave it while any remains. They also feed on dead frogs when they come in their way.

6842. *The culture* of this delicious fish, it is evident, might be successfully carried on in small ponds, or in canals in parks. In the former case supplying them with any animal or vegetable refuse. They wander far from their aquatic residence in quest of food, and that is the time when they are generally caught. A breeding stock may be obtained from any fisherman on the Thames or Trent, or by applying in Covent Garden, though they are by no means common in Britain. They are perhaps most common near Alnwick, in Northumberland.

6843. *The edible snail* (*Helix pomatia*, L. fig. 75 a), is a native of Italy; but being imported to this country about the middle of last century, is now considered as naturalized. Aubrey informs us, that they were introduced by Charles Howard, Esq. an epicure of the Arundel family, as an article of food, who scattered and dispersed those snails all over the downs and in the woods at Albury, an ancient seat of that noble family; and also near Ashted, Boxhill, Dorking, Epsom, and Surrey, where they have increased so greatly, that even the confines of Sussex abounds with them. His example was followed by others in different parts of the kingdom, but by none with so much success as by Sir Kenelm Digby, who dispersed them about Gothurst, the seat of that family near Newport-Pagnel, in Buckinghamshire.

745





6844. This is the largest species of land-snail in England. When full-grown, the shell is from an inch and a half to two inches in diameter in our climate; on the continent, towards the south, its size is much superior. The animal being large and fleshy, and not of an unpleasant flavor, has been esteemed as an article of food from early times. It was a favorite dish with the Romans, who had their cochlearia, or snail-stews, in which they were bred and fattened. Varro has handed down to us a description of these stews, and the manner of making them: he says, open places were chosen surrounded by water, that the snails might not abandon them, and care was taken that the places were not much exposed to the sun or to the dews. If a natural spring or moisture was not found, they formed an artificial one, by bringing a pipe to the stew bored full of holes, like a watering-pot, by which the place was continually sprinkled or moistened. The snails required little attention or food, for as they crawled they found it on the floor or area. They were fed with bran and sodden lees of wine, or similar substances intermixed with a few laurel-leaves. In the neighborhood of Vienna they are caught and preserved till wanted in large pits covered with boards; they are fed with cabbage-leaves, grains, bran, meal, or any vegetable refuse. In Italy and Vienna they are commonly sold in the markets, and are called bavoli, martinacci, and galinelle. In France, says Lister, they boil them in river water, and season them with salt, pepper, and oil. This practice continues at the present period.

6845. *The medicinal leech (Hirudo medicinalis, L.)*, grows to the length of two or three inches. The body is of a blackish-brown color, marked on the back with six yellow spots, and edged with a yellow line on each side; but both the spots and the lines grow faint, and almost disappear at some seasons. The head is smaller than the tail, which fixes itself very firmly on any thing the creature pleases. It is viviparous, and produces but one young at a time, which is in the month of July. It is an inhabitant of clear running waters, and is well known for its use in bleeding. If put into shallow clear ponds it will breed freely, and this is practised by some herbalists and apothecaries in the neighborhood of London. The chief supply, however, is from the lakes of Cumberland, where they are caught by women who go into the water bare-legged, and after a few have fastened, they walk out and pick them off. A good many are also brought from Holland.

---

## CHAP. XII.

### *Of Animals noxious to Agriculture.*

6846. *Almost every animal may be injurious to the agriculturist in some way or other.* All the cultivated live-stock will, if not excluded by fences, or prevented by herding, eat or tread down corn crops or other plants in culture. Those animals, as the dog and ferret, which assist him in deterring or in catching noxious animals which would prey on others, will themselves become depredators if not attended to; and even man, the only rational, and therefore the most valuable of agricultural servants, will prove, under certain circumstances, the greatest of all enemies to the agriculturist. We shall glance at the different animals more especially noxious in the order of their usual classification.

### SECT. I. *Of noxious Mammalia.*

6847. *Of noxious mammalia*, man, in a demoralised state, is the most injurious. The remedy is furnished by the law—the preventive is good education, and civil treatment by the master.

6848. *The fox (Canis vulpes)* commits great ravages among lambs, poultry, geese, &c. To destroy it, the farmer must take a sheep's paunch and fasten it to a long stick; then rub his shoes well upon the paunch, that the fox may not scent his feet. He should then draw his paunch after him as a trail, a mile or upwards, till he gets near some large tree; then leave the paunch and ascend into the tree with a gun; and as the night comes on, he may see the fox come after the scent of the trail, when he may shoot him. The trail should be drawn to the windward of the tree, if he can conveniently contrive so to do.—Or, set a steel-trap in the plain part of a large field, distant from paths and hedges; then open the trap, place it on the ground, cut out the exact shape thereof in a turf, and take out just so much earth to make room for it to stand, and then cover it again very neatly with the turf you cut out. As the joint of the turf will not close exactly, procure some mould of a mole-hill newly thrown up, and stick some grass on it, as if it grew there. Scatter some mould of the mole-hill very thin three different ways, at the distance of ten or twelve yards from the trap; let this mould be thrown on spots fifteen or sixteen inches square; and where the trap is placed, lay three or four small pieces of cheese; and then, with a sheep's paunch, draw a trail a mile or two long to each of these three places, and from thence to the trap, that the fox may approach one of the places first; for then he will advance to the trap more boldly; and thus you will be almost always sure of catching him. You must take care that your trap be left loose, that he may draw it to some hedge or covert, or he will otherwise bite off his leg, and so make his escape.—Or near the spot where the fox uses much to resort, fix a stick or pole, much

in the same manner as for a woodcock. To explain this more exactly: tie a string to some pole set fast in the ground, and to this string fasten a small short stick, made thin on the upper side, with a notch at the lower end of it; then set another stick fast in the ground, with a nick under it; bend down the pole, and let the nicks or notches join in the slightest degree: then open the noose or string, and place it in the path or walk of the fox. By strewing flesh-meat, pieces of cheese, &c., as you pass along, you may entice the fox to take the same road.

6849. *To shoot a fox*, anoint the soles of the shoes with swine's fat, a little broiled; then go towards the wood, and, in returning, drop here and there a bit of swine's liver, roasted and dipt in honey, drawing after you a dead cat; and by these means he therefore will be allured to follow you.

6850. *The fox is sometimes taken with a hook*, made of large wire, and turning on a swivel like the collar of a grevhound; it is usually hung so high from the ground, that he is compelled to leap to catch at it; and baited with fresh liver, cheese, &c., and if a trail be run with a sheep's paunch, as before directed, he will be drawn to the bait with the greatest ease.

6851. *The pole cat* (*Felis putorius*, L.) may be caught and destroyed by a dead-fall, constructed in the following manner. Take a square piece of wood, weighing forty or fifty pounds: bore a hole in the middle of the upper side, and set a crooked hook fast in it; then set four forked stakes fast in the ground, and lay two sticks across, on which sticks lay a long staff, to hold the dead fall up to the crook; and under this crook put a short stick, and fasten a line to it: this line must reach down to the bridge below; and this bridge you must make about five or six inches broad. On both sides of this dead-fall, place boards or pales, or edge it with close rods, and make it ten or twelve inches high. Let the entrance be no wider than the breadth of the dead-fall.—A pigeon house, surrounded with a wet ditch, will tend to preserve the pigeons; for beasts of prey naturally avoid water.

6852. *The weasel*, or *Foumart*, (*Felis vulgaris*, L.), though in some respects beneficial, in as much as when domesticated, it destroys rats, mice, moles, and other noxious vermin, is nevertheless, in a wild state, a formidable foe to poultry and rabbits. Weasels may be destroyed by putting in their haunts small pieces of paste, consisting of pulverized sal. ammoniac, mixed up with the white of an egg, wheaten flour, and honey. The strewing of rue round the place where hens nestle, is also said to drive away these depredators; as also will the smell of a burnt cat; as all animals are terrified at the burning of one of their own, or of a similar species.

6853. *The badger* (*Ursus meles*, L.) destroys great numbers of young pigs, lambs, and poultry every year. Some use a steel trap, or a spring, such as foxes are taken in, to catch them. Others sink a pit-fall, five feet in depth and four in length, forming it narrow at top and bottom, and wider in the middle; they then cover it with small sticks and leaves, so that the badger may fall in when he comes on it. Foxes are sometimes taken in this manner. Others, again, pursue a badger to his hole, and dig him out, this is done by moonlight.

6854. *The mole* (*Talpa europæa*) is injurious by the subterraneous roads and hills of earth which it forms in grass lands. With regard to the removal of mole hills, various practices are in use; but the most effectual is that derived from the experience of a successful mole-catcher, and communicated to the public by Dr. Darwin, in his *Phytologia*. This man commenced his operations before sun-rising, when he carefully watched their situation; and frequently observing the motion of the earth above their walks, he struck a spade into the ground behind them, cut of their retreat, and then dug them up. As moles usually place their nests at a greater depth in the ground than their common habitation lies, and thus form an elevation or mole-hill, the next step is to destroy these nests by the spade; after which the frequented paths are to be distinguished from the bye-roads, for the purpose of setting subterraneous traps. This object may be effected by marking every new mole-hill with a slight pressure of the foot, and observing the next day whether a mole has passed over it, and destroyed such mark; and this operation should be repeated two or three mornings successively, but without making the pressure so deep as to alarm the animal, and occasion another passage to be opened. Now the traps are to be set in frequented paths, and should be made of a hollow, wooden semi-cylinder, (fig. 283.), each end of which should be furnished with grooved rings, containing two nooses of horse-hair, that are loosely fastened in the centre by means of a peg, and are stretched above the surface of the ground by a bent stick or strong hoop. As soon as the mole passes half-way through one of these nooses, and removes the central peg in its course, the hoop, or bent stick, rises in consequence of its elasticity, and of course strangles the mole. The simplicity of this mode of destroying mole-hills and moles, recommends itself to general adoption, as those whose grounds are thus infested may easily extirpate them, by teaching this practice to their laborers.

6855. *The domestic rat* (*Mus rattus*, L., fig. 746.) and *common mouse*, (*M. musculus*, L.) are extremely destructive to the farmer, whose interest it becomes to extirpate as many as possible. Among the various expedients suggested for this purpose, the following have been found the most successful.

6856. When a rat or mouse has been caught, cut or beat him severely, and let him go; and he will make such a crying noise, that his companions will desert the place. Some persons, indeed, flea off the skin of their heads; but this method of extermination is too cruel to be recommended to the practice of any humane person: or, put a piece of fried rusty bacon in the middle of a board, three feet square, and cover the board pretty thickly with bird-lime, leaving some narrow alleys for the vermin to get at the bacon, in doing which they will frequently get among the lime and be caught. In Staffordshire it is customary to put bird-lime about the holes, amongst which they run; and, the bird-lime adhering to them, they will not cease scratching until they kill themselves.—Or, mix the expressed juice of the deadly night-shade with wheaten flour or oat-meal; cut the paste into small pieces, and put them in the holes or tracks frequented by the rats: though they will not eat this nauseous dose, its smell is so exceedingly offensive that they will immediately decamp. Of course, the renewal of this preparation, as often as it loses its odor, will prove an effectual barrier to the return of these vermin. In order to prevent accidents to domestic animals from the poisons usually employed, it has been suggested to place the baits in the traps, and to enclose the traps in cases, having holes in the ends of them large enough to admit rats, but small enough to exclude cats, dogs, &c.

6857. The two following expedients for destroying rats are given in Willick's *Domestic Encyclopædia*, vol. iii. Among other remedies, he recommends that commonly employed on the continent, when a sponge is fried with salt butter in a pan; then compressed between two plates, and cut into small pieces, which are scattered about the holes frequented by rats and mice. This preparation is devoured with avidity; it excites thirst in the animals, which should be gratified by exposing shallow vessels containing water. On drinking this fluid, after having swallowed the burnt sponge, it distends their stomach, and proves a fatal repast.—Or, a capacious cask of moderate height must be procured, and put in the vicinity of places infested with rats. During the first week, this vessel is only employed to allure the rats to visit the solid top of the cask, by means of boards or planks arranged in a sloping direction to the floor, which are every day strewn with oat-meal, or any other food equally grateful to their palate; and the principal part of which is exposed on the surface. After having thus been lulled into security, and accustomed to find a regular supply for their meals, a skin of parchment is substituted for the wooden top of the cask, and the former is cut for several inches, with transverse incisions through the centre, so as to yield on the smallest pressure. At the same time, a few gallons of water, to the depth of five or six inches, are poured into the empty cask. In the middle of this element a brick or stone is placed, so as to project one or two inches above the fluid; and that one rat may find on the former a place of refuge. These preparatory measures being taken, the boards as well as the top of the cask should now be furnished with proper bait, in order to induce them to repeat their visits. No sooner does one of these marauders plunge through the section of the parchment into the vessel, than it retreats to the brick or stone, and commences its lamentations for relief. Nor are its whining notes uttered in vain; others soon follow, and share the same fate; when a dreadful conflict begins among them, to decide the possession of the dry asylum. Battles follow in rapid succession, attended with such loud and noisy shrieks, that all the rats in the neighborhood hasten to the fatal spot, where they experience similar disasters. Thus hundreds may be caught by a stratagem, which might be greatly facilitated by exposing a living rat taken in a trap, or purchased from a professional rat-catcher.

6858. A successful mode of enticing rats has been lately practised by Broad, a farmer at Thrupton in Herefordshire. He uses a bore trap, two feet long, eight inches wide, and nine inches deep, and little different in construction from the common one. His secret consists in scenting light colored malt, and also some wheat straws with oil of carraways, and not setting the traps for a day or two till the rats have been accustomed to eat the malt without fear. (*F. Mag.* xiv. p. 421.)

6859. The water or field rat (*Mus amphibius*, L.), and the field mouse (*M. terrestris*, fig. 747.), may be destroyed as follows. Go out in the dog-days, when the fields are tolerably bare; and having found their nests or holes, (which in shape and size resemble augur-holes) put therein hemlock-seed, or hellebore, mixed with barley, of which they will eat so as to destroy themselves. As those vermin frequently consume seed-corn after it is deposited in the ground, it has been suggested to steep it in bull's gall, which will impart to it such a bitter taste that they will not touch it. Some persons mix sand with their stacked corn, which deters them from burrowing in it, by falling into the ears. The following method has been found very effectual. Fill an earthen pot half-full of water, and cover it over with a board that has a hole in the middle, then cover the board over with straw, pea-haulm, or similar rubbish; under which the vermin will take shelter, and, creeping to the hole, will fall through and be drowned in the water.

## SECT. II. Birds injurious to Agriculture.

6860. Of the *aves*, the species more peculiarly injurious to the agriculturist is the kite, (*Falco milvus*, L.), by its attacks on young poultry. To ensnare them proceed as follows. Near the place where poultry are kept, let iron gins be fixed, about four inches broad, which must be baited with chicken, mice, or raw meat; and thus these ravenous fowls are easily taken. Some persons stretch lines or nets over the place where the fowls are; but nothing drives them away like a well charged gun. Or, steep the entrails of pigs, fowls, or rabbits, in the lees of wine, into which you have infused a quantity of *nux vomica*, and throw the bait where the fowls come in the evening, or early in the morning. This will intoxicate them so that a person waiting near the spot may easily take them.



6861. *All the granivorous birds are injurious to the farmer at seed time and harvest, and must be deterred by watching or shooting, by scare-crows, as figures of men, cats, &c., by rags dipped in bruised gunpowder and tar, renewed every day or two; but chiefly by shooting and fixing up the victims in different places. It must always be recollected that birds are, with very few exceptions, insectivorous as well as granivorous, and that frequently they may do much good in destroying the grub and wire worm. This is more especially the case with the crow tribe, (Corvus, L.) (See Encyc. of Gard. § 2223.)*

### SECT. III. *Insects injurious in Agriculture.*

6862. *The insect tribes are by far the most dangerous animals that the agriculturist has to contend with; and injurious as they are in Britain, their destructive effects are here but trifling compared to what is experienced from the locust in eastern countries, and various insects in North America. Dr. Dwight, in his Travels in New England, relates accounts of the Hessian fly (Tipula), destroying the crops of entire districts, and rendering it impossible to cultivate a particular variety of wheat. It made its first appearance in New England in 1787, and advanced at the rate of 20 miles a year. A caterpillar called the palmer worm appeared in 1770. Its march was from west to east; walls and fences were no obstruction to its course, nor indeed was any thing else, except the sides of trenches. It destroyed, rather than devoured, ascending a stalk of grass, or grain, cutting it off in a moment, and, without staying to eat any part of it, rapidly repeating the same process on all which stood its way. The meadows, where it most abounded, appeared as if they had been mown with a dull scythe; and the grain, as if it had been reaped with a sickle which had gaps, and therefore had cut the stalks in a scattering, slovenly manner. In some places, immense multitudes of these animals died in the trenches, which were formed to stop their progress, and were left uncovered. The mass soon became foetid and loathsome; and was supposed in several instances, to produce a fever distressing, and sometimes fatal. The canker worm, another caterpillar, lives on apple-trees, and entirely strips them of their leaves in the course of four weeks. A sort of grasshopper appears occasionally in vast numbers, and not only eats every thing of the vegetable kind, but even "the garments of labourers hung up in the field while they are at work, which they destroy in a few hours." (Dwight's Travels, vol. ii. p. 384.) Every species of larger animal and plant seems to have a particular species of insect which it is destined to support, and to which it will fall a victim unless in vigorous health; and in the case of animals, not only in good health, but in the habit of using the means which nature or art suggests for their suppression or destruction. We shall first offer some general remarks on the nature of insects, and next describe a few belonging to each of the Linnæan orders.*

#### SUBJECT. 1. *Of the Physiology of the Insect Tribes.*

6863. *Insects are distinguished from quadrupeds, birds, and reptiles by their more numerous feet, being without bones, and by their head being furnished with a pair of antennæ or horns. From the vermes, or worm-like animals, insects are sufficiently distinguished by their having feet.*

6864. *Taking a general view of insects we find most of them are oviparous; of course the first state in which insects appear is that of an ovum or egg. This relates to the generality of insects, for there are some examples of viviparous insects, as in the general aphid, musca, &c. The eggs of insects (fig. 748) are of two sorts: the first membranaceous, like the eggs of the tortoise, and the other reptiles; the other covered with a shell like those of the birds. Their figure varies exceedingly; some are round, some elliptical, some lenticular, some cylindrical, some pyramidal, some flat, some square, but the round and oval are the most common. As an example of the various shapes of the eggs of insects, and of their natural as well as magnified size, we refer to those of the common slug (a), phalæna nupta (b), brown-tailed moth (c), currant moth (d), common gooseberry moth (e), turnip butterfly (f), spider (g), house cricket (h), and common chaffer (i).*

6865. *The eggs of insects seldom increase in size, from the time they have been deposited by the parent, till they are hatched; those of the tenthredo, however, and of some others, are observed to increase in bulk. At first there is nothing to be perceived in the eggs of insects but a watery fluid; after some little time, the head, like an obscure point, is observable in the centre. The little insect remains in the egg till its limbs have acquired strength to break the egg and make its escape; the different species of insects remain enclosed in the egg for very different periods; some continue enclosed only a few days,*



others remain for several months. The eggs of many insects remain without being hatched during the whole winter, and the young insects do not come forth from them till the season at which the leaves of the vegetables on which they feed begin to expand.

6866. *The insect in its second or caterpillar state (fig. 749.)* has been usually known



by the name of *eruca* or *larva*, being a sort of masked form or disguise of the insect in its complete state. The larvæ of insects differ very much from each other, according to the several tribes to which they belong; those of the butterfly (*Papilio*) and moth (*Phalena*) tribes are generally known by the name of caterpillars; those of the beetle (*Scarabæus*), except such as inhabit the water, are of a thick, clumsy form, called grubs. The larvæ of the locust or grasshopper (*Gryllus*), do not differ much in appearance from the complete insect; except being without wings. The larvæ of flies (*Musca*), bees (*Apis*), &c. are generally known by the name of maggots, and are of a thick short form. Those of water-beetles (*Dytiscus*) are of very singular forms, and differ, perhaps, more from that of the complete insect than any other, except those of the butterfly tribe. Some insects undergo no change of shape, but are hatched from the egg complete in all their parts, and they undergo no farther alteration than that of casting their skin from time to time, till they acquire the complete resemblance of the parent animal. In the larva state most insects are peculiarly voracious, as are many of the common caterpillars. In their perfect state some insects, as butterflies, are satisfied with the lightest nutriment, while others devour animal and vegetable substances with a considerable degree of avidity. As an example of the caterpillar state of some of the commoner insects, we may refer to that of the privet moth (*Sphinx ligustri*, fig. 749 a); the cabbage butterfly (*Papilio brassica*, b); the turnip butterfly (*P. napi*, c); gooseberry moth (*Phalena wawaria*, d); the currant moth (*Ph. grossularia*, e); the dragon fly (*Libellula virgo*, f); the common chafer (*Scarabæus melolontha*, g); the phryganea rhombica (h); the frog-hopper (*Cicada spumaria*, i); and the musca pumilionis (k).

6867. *When the larva is about to change into the chrysalis or pupa state (fig. 750.)* it

ceases to feed, and having placed itself in some quiet situation, lies still for several hours, and then, by a sort of effort, it divests itself of its external skin, and immediately appears in the different form of a chrysalis or pupa; in this state, likewise, the insects of different genera differ almost as much as the larvæ. In most of the beetle tribe it is furnished with short legs, capable of some degree of motion, though very rarely exerted. In the butterfly tribe it is destitute of legs; but in the locust tribe it differs very little from the perfect insect, except in not having the wings complete. In most of the fly tribe it is perfectly oval, without any apparent motion or distinction of parts. The pupa of the bee is not so shapeless as that of flies, exhibiting the faint appearance of limbs. Those of the dragon fly (*Libellula*) differ most widely from the appearance of the complete insect; from the pupa emerges the image or insect in its ultimate form, from which it never changes, nor receives any farther increase of growth. As examples of the chrysalis of various insects, we give those of the beetle (*Scarabæus*



6861. *All the granivorous birds are injurious to the farmer at seed time and harvest, and must be deterred by watching or shooting, by scare-crows, as figures of men, cats, &c., by rags dipped in bruised gunpowder and tar, renewed every day or two; but chiefly by shooting and fixing up the victims in different places. It must always be recollected that birds are, with very few exceptions, insectivorous as well as granivorous, and that frequently they may do much good in destroying the grub and wire worm. This is more especially the case with the crow tribe, (Corvus, L.) (See Encyc. of Gard. § 2223.)*

### SECT. III. *Insects injurious in Agriculture.*

6862. *The insect tribes are by far the most dangerous animals that the agriculturist has to contend with; and injurious as they are in Britain, their destructive effects are here but trifling compared to what is experienced from the locust in eastern countries, and various insects in North America. Dr. Dwight, in his Travels in New England, relates accounts of the Hessian fly (Tipula), destroying the crops of entire districts, and rendering it impossible to cultivate a particular variety of wheat. It made its first appearance in New England in 1787, and advanced at the rate of 20 miles a year. A caterpillar called the palmer worm appeared in 1770. Its march was from west to east; walls and fences were no obstruction to its course, nor indeed was any thing else, except the sides of trenches. It destroyed, rather than devoured, ascending a stalk of grass, or grain, cutting it off in a moment, and, without staying to eat any part of it, rapidly repeating the same process on all which stood its way. The meadows, where it most abounded, appeared as if they had been mown with a dull scythe; and the grain, as if it had been reaped with a sickle which had gaps, and therefore had cut the stalks in a scattering, slovenly manner. In some places, immense multitudes of these animals died in the trenches, which were formed to stop their progress, and were left uncovered. The mass soon became fetid and loathsome; and was supposed in several instances, to produce a fever distressing, and sometimes fatal. The canker worm, another caterpillar, lives on apple-trees, and entirely strips them of their leaves in the course of four weeks. A sort of grasshopper appears occasionally in vast numbers, and not only eats every thing of the vegetable kind, but even "the garments of labourers hung up in the field while they are at work, which they destroy in a few hours." (Dwight's Travels, vol. ii. p. 384.) Every species of larger animal and plant seems to have a particular species of insect which it is destined to support, and to which it will fall a victim unless in vigorous health; and in the case of animals, not only in good health, but in the habit of using the means which nature or art suggests for their suppression or destruction. We shall first offer some general remarks on the nature of insects, and next describe a few belonging to each of the Linnæan orders.*

#### SUBJECT. 1. *Of the Physiology of the Insect Tribes.*

6863. *Insects are distinguished from quadrupeds, birds, and reptiles by their more numerous feet, being without bones, and by their head being furnished with a pair of antennæ or horns. From the vermes, or worm-like animals, insects are sufficiently distinguished by their having feet.*

6864. *Taking a general view of insects we find most of them are oviparous; of course the first state in which insects appear is that of an ovum or egg. This relates to the generality of insects, for there are some examples of viviparous insects, as in the general aphid, musca, &c. The eggs of insects (fig. 748) are of two sorts: the first membranaceous, like the eggs of the tortoise, and the other reptiles; the other covered with a shell like those of the birds. Their figure varies exceedingly; some are round, some elliptical, some lenticular, some cylindrical, some pyramidal, some flat, some square, but the round and oval are the most common. As an example of the various shapes of the eggs of insects, and of their natural as well as magnified size, we refer to those of the common slug (a), phalæna nupta (b), brown-tailed moth (c), currant moth (d), common gooseberry moth (e), turnip butterfly (f), spider (g), house cricket (h), and common chafer (i).*

748



6865. *The eggs of insects seldom increase in size, from the time they have been deposited by the parent, till they are hatched; those of the tenthredo, however, and of some others, are observed to increase in bulk. At first there is nothing to be perceived in the eggs of insects but a watery fluid; after some little time, the head, like an obscure point, is observable in the centre. The little insect remains in the egg till its limbs have acquired strength to break the egg and make its escape; the different species of insects remain enclosed in the egg for very different periods; some continue enclosed only a few days,*

others remain for several months. The eggs of many insects remain without being hatched during the whole winter, and the young insects do not come forth from them till the season at which the leaves of the vegetables on which they feed begin to expand.

6866. *The insect in its second or caterpillar state (fig. 749.)* has been usually known



by the name of *eruca* or larva, being a sort of masked form or disguise of the insect in its complete state. The larvæ of insects differ very much from each other, according to the several tribes to which they belong; those of the butterfly (*Papilio*) and moth (*Phalæna*) tribes are generally known by the name of caterpillars; those of the beetle (*Scarabæus*), except such as inhabit the water, are of a thick, clumsy form, called grubs. The larvæ of the locust or grasshopper (*Gryllus*), do not differ much in appearance from the complete insect; except being without wings. The larvæ of flies (*Musca*), bees (*Apis*), &c. are generally known by the name of maggots, and are of a thick short form. Those of water-beetles (*Dytiscus*) are of very singular forms, and differ, perhaps, more from that of the complete insect than any other, except those of the butterfly tribe. Some insects undergo no change of shape, but are hatched from the egg complete in all their parts, and they undergo no farther alteration than that of casting their skin from time to time, till they acquire the complete resemblance of the parent animal. In the larva state most insects are peculiarly voracious, as are many of the common caterpillars. In their perfect state some insects, as butterflies, are satisfied with the lightest nutriment, while others devour animal and vegetable substances with a considerable degree of avidity. As an example of the caterpillar state of some of the commoner insects, we may refer to that of the privet moth (*Sphinx ligustri*, fig. 749 a); the cabbage butterfly (*Papilio brassica*, b); the turnip butterfly (*P. napi*, c); gooseberry moth (*Phalæna wawaria*, d); the currant moth (*Ph. grossularia*, e); the dragon fly (*Libellula virgo*, f); the common chafer (*Scarabæus melolontha*, g); the phryganea rhombica (h); the frog-hopper (*Cicada spumaria*, i); and the musca pumilionis (k).

6867. *When the larva is about to change into the chrysalis or pupa state (fig. 750.)* it ceases to feed, and having placed itself in some quiet situation, lies still for several hours, and then, by a sort of effort, it divests itself of its external skin, and immediately appears in the different form of a chrysalis or pupa; in this state, likewise, the insects of different genera differ almost as much as the larvæ. In most of the beetle tribe it is furnished with short legs, capable of some degree of motion, though very rarely exerted. In the butterfly tribe it is destitute of legs; but in the locust tribe it differs very little from the perfect insect, except in not having the wings complete. In most of the fly tribe it is perfectly oval, without any apparent motion or distinction of parts. The pupa of the bee is not so shapeless as that of flies, exhibiting the faint appearance of limbs. Those of the dragon fly (*Libellula*) differ most widely from the appearance of the complete insect; from the pupa emerges the imago or insect in its ultimate form, from which it never changes, nor receives any farther increase of growth. As examples of the chrysalis of various insects, we give those of the beetle (*Scarabæus*



constituting one of the heaviest afflictions that can happen to a country. The mischiefs done by the blattæ, or cock-roaches, is trifling compared with those of this destroying tribe, for the dreadful ravages committed by the locusts are such as to reduce the most fertile fields to the appearance of barren deserts; they devour the fruits, leaves, and even the buds and bark of trees, and have even been known to devour the reeds used in thatching the human habitations, so unfortunate as to be visited by these devouring hordes. Jackson depicts their ravages in the empire of Morocco, and gives a figure of the insect (fig. 755.) of half the natural size. In Abyssinia, China, and other countries, the caterpillar or larva of certain species of roaches and locusts is, like that of some beetles, eaten by the natives.

6882. A species of grasshopper apparently peculiar to New England is mentioned by Dr. Dwight, as appearing periodically. He says, "As I had no opportunity of examining them, I cannot describe their form or their size. Their favorite food is clover and maize. Of the latter, they devour the part which is called the silk, the immediate means of fecundating the ear, and thus prevent the kernel from coming to perfection. But their voracity extends to almost every vegetable, even to the tobacco plant and the burdock. Nor are they confined to vegetables alone. The garments of laborers, hung up in the field while they are

at work, these insects destroy in a few hours, and with the same voracity they devour the loose particles which the saw leaves upon the surface of pine boards, and which, when separated, are termed saw-dust. The appearance of a board fence, from which the particles had been eaten in this manner, and which I saw, was novel and singular, and seemed the result, not of the operations of the plane, but of attrition, the cause of which I was unable to conjecture. At times, particularly a little before their disappearance, they collect in clouds, rise high in the atmosphere, and take extensive flights, of which neither the cause nor the direction has hitherto been discovered. I was authentically informed in Shaftsbury, that some persons, employed in raising the steeple of the church in Williamstown, were, while standing near the vane, covered by them; and saw at the same time vast swarms of them flying far above their heads. The customary flight of grasshoppers rarely exceeds four or five yards, and their wings are apparently so weak as to forbid excursions extended much beyond these limits. It is to be observed, however, that they customarily return, and perish on the very grounds which they have ravaged." (Dwight's Travels, &c. vol. ii. p. 385.)

6883. The frog-hopper, or cuckoo-spit insect, (*Cicada*), feeds on various kinds of plants; the grub or larva is without wings; in the pupa the wings are very short; but in both states they are exceedingly active. The males are distinguishable by their loud chirping note, the females are quite mute. In the fly state, they are found on the leaves and stems of plants, and in the immature state about the roots of grass and trees. The white froth-like spittle, which is seen on the leaves and stalks of many kinds of plants in the summer season, is produced by the black-headed frog-hopper (*Cicada spumaria*, fig. 754 b), and if this froth be wiped off and examined, it will be found to contain the larva or young of the cicada; and this matter, which is discharged from its own body, no doubt serves to protect it from the attacks of other insects.

6884. The plant-louse, vine-fretter, or puceron, (*Aphis*) is a very common insect, the numerous species being denominated from the trees and plants which they infest. The males are winged, and the females without wings; they are viviparous, producing their young alive in the spring; and also oviparous, laying eggs in the autumn. As these insects derive their nourishment from the juices of the plants which they infest, nature has wisely ordained that the females should lay eggs in the autumn, though they bring forth their young alive all the spring and summer months. This is to prevent them from being starved for the want of food in winter. The young burst forth from their eggs in spring as soon as there are leaves to subsist upon. Their noxious effects are well known to the gardener. They sometimes migrate, and suddenly fall in showers on spots that were until then free from their ravages. Water dashed with force from a syringe will prove as destructive to them as any thing when on trees; and smaller plants may be washed with lime-water, with tobacco-water, with elder leaves infused in water, or with common soap-suds, any of which will destroy the insects. The larvæ of the lady-bird eat thousands of them, some species of ichneumon and common ants also destroy them; and some conjecture that it would probably prove serviceable to scatter ants, which may always be procured in abundance, upon infested trees. The aphides sometimes settle upon the tops of beans, covering them so thickly as to make them appear quite black: in such cases the crops may often be preserved by cutting off the tops, a practice which is likewise adopted, independently of this pest requiring it, for the purpose of increasing the yield of beans. (Dr. Skrimshire's Essays, *Introd. to Nat. Hist.*, vol. i. p. 149.) The rose-tree is, after a mild spring, greatly injured by a species of aphid (*A. rosæ*). The best mode of remedying this evil is to lop off the infested shoots before the insects are greatly multiplied, repeating the same operation before the eggs are deposited. By the first pruning a very numerous increase will be prevented, and by the second, the following year's supply may, in a great measure, be cut off. If it were not for the numerous enemies to which the aphid is exposed, their wonderful fecundity is such that the leaves, branches, and stems of every plant would be totally covered with them. Myriads of insects of different classes, of different genera, and of different species, seem to be produced for no other purpose than to devour the aphid. On every leaf inhabited by them we find caterpillars of different kinds. These feed not upon the leaves, but upon the pucerons, whom they devour with an almost incredible rapacity. Some of these larvæ are transformed into insects with two wings, others into flies with four wings, and others into beetles. While in the larva state one of these glutinous insects will suck out the vitals of twenty pucerons in a quarter of an hour. Reaumur supplied a single caterpillar with more than a hundred pucerons, every one of which it devoured in less than three hours.

6885. The chermes (fig. 754 c, d, e.) is a genus very generally confounded with aphid; it also inhabits the leaves and stems of plants, and by its punctures, produces excrescences and protuberances of various sizes and shapes, which are generally found to enclose either the egg or immature insect, in the larva state; it is six-footed, hairy or woolly, and without wings; and in the pupa are two protuberances from the thorax, which are the rudiments of the future wings. The winged insects (c) leap or spring with great agility, and infest a number of different trees and plants: the females (d); by means of a tube at the termination of their bodies, insert their eggs under the surface of the leaves; and the worms, when hatched, give rise to those tubercles, or galls, with which the leaves of the ash, the fir, and other trees, are sometimes almost entirely covered. The old females, before depositing their eggs, expand to a comparatively large size (e).

6886. The thrips genus (fig. 754 f.) consists of very small insects, found chiefly on the flowers of plants, and, excepting when very numerous, are not very detrimental. The natural size is very minute, and therefore to search for this insect a magnifying glass is required.

6887. Of the cochineal or coccus genus (fig. 754 g.) there are several species very injurious in gardens, the peach, vine, pine, and orange bugs. They are very well known to gardeners, and are almost exclusively found in hot-houses. The males are active, but the females are very inert, being generally fixed to different parts of plants. The eggs, of their natural size, are mere dots, magnified (g) they appear of an oval shape; the larva is proportionally small, but magnified (h) is oblong and roundish; the males (i) only have wings, and require to be magnified to show their form (k); the female attains a considerable size (l), and,

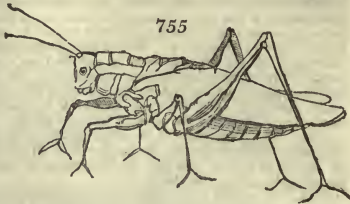



when hatching, becomes enveloped in a case of wool (*m*). Brushing off these creatures is the only effectual remedy, and, if set about at once and persevered in, will save the trouble of many prescribed washes and powders, which are mere palliatives. Happily the British agriculturist has little to do with them.

#### SUBJECT. 4. *Of Lepidopterous Insects.*

6888. *The lepidoptera* contains the butterfly, moth, and hawk-moth; they have four wings covered with scales or a sort of farina; they have a mouth, with palpi, a spiral tongue, and the body covered with hair. The scales resemble feathers; they lie over one another in an imbricated manner, the shaft towards the body of the insect, and the expansion towards the end of the wing, reflecting the most brilliant colors.

6889. *Of the butterfly genus (Papilio, L.)* many thousand species are known in Europe, and in England alone more than eleven hundred have been collected by one celebrated entomologist.

6890. *The larvæ, or young,* of the different kinds of butterflies and moths, when in that state in which they come from the egg, are called caterpillars. These, which are very minute at first, feed generally on the leaves of vegetables, and increase in size. They cast their skins occasionally, and sometimes change in color and markings, but never in their general appearance or in their habits. Eating seems to be their sole employment; and when they meet with food that suits their palate they are extremely voracious, committing great havoc in gardens. But the same cause which restrains the depredations of the aphides and other insects has also set bounds to the destruction occasioned by the caterpillar, who has myriads of internal as well as external enemies. Many flies deposit their eggs in the bodies of caterpillars. From these eggs proceed small maggots, which gradually devour the vitals of the animal in which they reside. When about to be transformed into chrysalids, they pierce the skin of the caterpillar, spin their pods, and remain on the empty skin till they assume the form of flies, and escape into the air to perform the same cruel office to another unfortunate larva. Every person must recollect to have seen the colewort or cabbage caterpillar stuck upon old walls, or the windows of country cottages, totally covered with these chrysalids, which have the form of small maggots, and are of a fine yellow colour. One of the most formidable enemies of the caterpillar is a black worm, with six crustaceous legs: it is longer and thicker than an ordinary-sized caterpillar. In the fore part of the head it has two curved pincers, with which it quickly pierces the belly of a caterpillar, and never quits the prey till it is entirely devoured. The largest caterpillar is not sufficient to nourish this larva for a single day; for it daily kills and eats several of them. These gluttons, when gorged with food, become unactive, and almost motionless; when in this satiated condition, young larvæ of the same species attack and devour them. Of all trees, the oak perhaps nourishes the greatest number of different caterpillars, as well as of different insects. Among others, the oak is inhabited by a large and beautiful beetle. This beetle frequents the oak, probably because that tree is inhabited by the greatest number of caterpillars. It marches from branch to branch, and, when disposed for food, attacks and devours the first caterpillar that comes in its way.

6891. *Chrysalis state.* When full grown, the caterpillar seeks some retreat, to prepare for an important change, viz. from the soft caterpillar, possessing motion and feeding so voraciously, to the hard chrysalis, fixed immovably, and sustained without food. The retreat that is chosen and the preparation that is made for this important change vary essentially in different species: some retire to the sheltered situations of houses, walls, and other buildings; some bury themselves in the ground; some wrap themselves up in leaves; others attach themselves to the stalks of plants; while others again eat into the stems of vegetables, or the very heart of trees, and there undergo their metamorphosis. Although each kind of caterpillar seeks a different retreat, yet all of the same species seek the same, and adopt the same means of preservation. Such as are to lie dormant all winter, seek the warmth of our houses, or dig their way into the ground, below the influence of the expected frosts. Such as are to leave their prisons in a few weeks, and before the end of summer, roll themselves up in the leaves of those plants on which they fed. No caterpillar that is to remain in the state of a chrysalis till the following summer, attaches itself to an annual plant; and none that is to enter on its winged state in winter (which some few do) is ever found but upon evergreens. In the preparation which is made for their metamorphosis, caterpillars differ as much as in their selection of a proper place. Some attach themselves by a thread from their tails, and are suspended perpendicularly; while others, among which is the white cabbage butterfly, by another thread across the body, are suspended horizontally. The silk-worm and several others spin a complete covering or case for their bodies, some of finer materials and less agglutinated together than others. Some caterpillars form a ball or nest of the mould in which they are buried, glued together by their saliva, and smoothed within; and others fasten two leaves together, or, curling its edges, unite two parts of the same leaf by threads and bands, and thus form a covering and safe retreat for themselves.

6892. *Perfect insect.* After the animal has lain dormant its due time in the chrysalis state, the skin or shell bursts, and the perfect insect, in its winged state, creeps out, gradually expands its wings, and, when dried, becomes a gay inhabitant of the air. It now no longer seeks to satisfy its hunger on the gross food that it devoured when a caterpillar, but sips the nectar from the blossoms of the flowers. Having fulfilled the intentions of nature, they deposit their eggs with care, and, having thus provided for a future generation, the insect terminates its short but brilliant career. In the deposition of their eggs, the parent butterflies and moths display wonderful instinct in selecting precisely such places as are best adapted to their future young; such plants, for instance, as will furnish food for the new-born caterpillars, and such parts of plants as are not likely to be removed by decay, or such as will be exactly in the required stage of maturity at the time when the caterpillars are to be born. Thus, a little insect (*Tinea pomona*) lays its eggs in the blossom, that its caterpillar may feed on the fruit of the apple; and several others act in the same provident way.

6893. *The most remarkable British butterflies* are — the purple emperor (*Papilio iris*), which appears in July, and is considered the most beautiful: the peacock butterfly, (*P. Io*), whose wings are of a brownish-red color with black spots, is sufficiently common in the south of England, but extremely rare in the north: the tortoise-shell butterfly (*P. urticae*, fig. 756.) which appears in its winged state about the month of April, is one of the most common, at the same time the most beautiful of the British lepidoptera; the upper wings are red, and marked with alternate bands of black and pale orange; the eggs (*a*), caterpillar (*b*), and chrysalis (*c*) are each elegant in their kind. The mazarine blue butterfly (*P. cymon*) is also an admired species

756



6894. *The hawk-moth, sphynge, or sphinx*, is chiefly seen in the evening. The name sphynx is applied to the genus on account of the posture assumed by the larvæ of several of the larger species, which are often seen in an attitude much resembling that of the Egyptian sphynx, with the fore parts elevated, and the rest of the body applied flat to the surface. One of

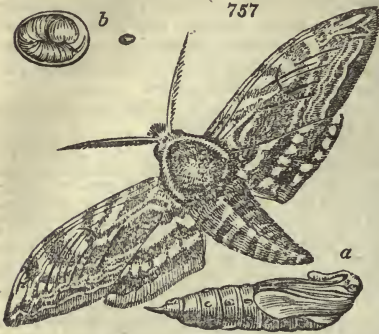

wings are of a bright orange color, marked by a pair of transverse black bands: the body is also orange-colored, with the sides marked by black bars: on the top of the thorax is a very large patch of a most singular appearance, exactly resembling the usual figure of a skull, or death's head, and is of a pale grey, varied with dull ochre color and black. When in the least disturbed or irritated, this insect emits a stridulous sound, sometimes like the squeaking of a bat or mouse; and from this circumstance, as well as from the mark above mentioned, is held in much dread by the vulgar in several parts of Europe, its appearance being regarded as a kind of ill omen, or harbinger of approaching fate. The caterpillar from which this curious sphynx proceeds, which is principally found on the potatoe and the jessamine, is in the highest degree beautiful, measuring sometimes five inches in length; its color is a bright yellow, and its sides are marked by stripes of a mixed violet and sky-blue color. It usually changes into a chrysalis in the month of September, and emerges the complete insect in June or July following: some individuals; however, change in July or August, and produce the moth in November.

6895. *The moths (Phalænæ)* are a numerous genus like the sphinges. They fly abroad only in the evening and during the night, and obtain their food from the nectar of flowers. The larva is active and quick in motion, and preys voraciously on the leaves of plants. The most remarkable British moths are the *clothes-moth (P. sarcitella, fig. 758 a)*; the eggs of which are deposited on woollen clothes, furs, &c. on which the larvæ feed and change to chrysalids, appearing in the imago state in August. The most troublesome in gardens are the *cabbage-moth (P. oleracea, b)*; the *gooseberry-moth (P. uavaria, c)*; the *currant-moth (P. grossularia, d)*; and the *codling-moth*, common on fruit-trees, hedges, and oak-trees, (*P. pomonella, e*).

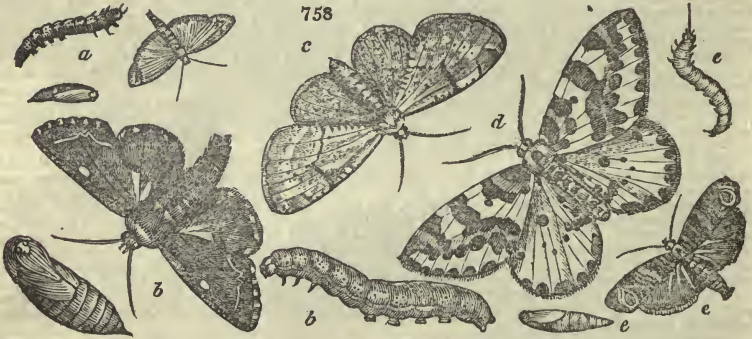

#### SUBJECT. 5. Of Neuropterous, or Nerve-winged Insects.

6896. *The neuroptera, or nerve-winged insects*, have four naked membranaceous wings, but no sting; and they differ from the last order, as their wings are without their minute scales or down. Most of the insects in this family are aquatic, residing in the water during their immature state, and resorting thereto in their perfect state.

6897. *The dragon-fly (Libellula)* is well known as frequenting rivers, lakes, pools, and stagnating waters, in which the females deposit their eggs. The egg, when deposited by the parent in the water, sinks to the bottom, and remains there till the young insect has acquired sufficient maturity and strength to burst from its confinement. The larva, at first small, increases to nearly half the size of the perfect fly, by changing its skin at different intervals, like the caterpillars of moths and butterflies. The slender-bodied dragon-fly (*L. virgo, fig. 759 a*) is the most common.

6898. *The day-fly (Ephemera)* differs in many respects from all other insects. The larvæ live in the water, where earth and clay seem to be their only nourishment, for three years, the time they consume in preparing for their change, which is performed in a few moments. The larva, when ready to quit that state, rises to the surface of the water, and getting instantaneously rid of its skin, becomes a chrysalis. This chrysalis is furnished with wings, which it makes use of to fly to the nearest tree or wall; and there settling, it in the same moment quits a second skin, and becomes a perfect ephemera. In this state all the species live but a very short time, some of them scarcely half an hour, having no other business to perform than that of continuing the race. They are called the insects of a day; but very few of them ever see the

light of the sun, being produced after sunset, during the short nights of summer, and dying long before the dawn. All their enjoyments, therefore, excepting coition, are confined to their larva state. The *E. vulgata* (fig. 759 *b*) is the largest British species.

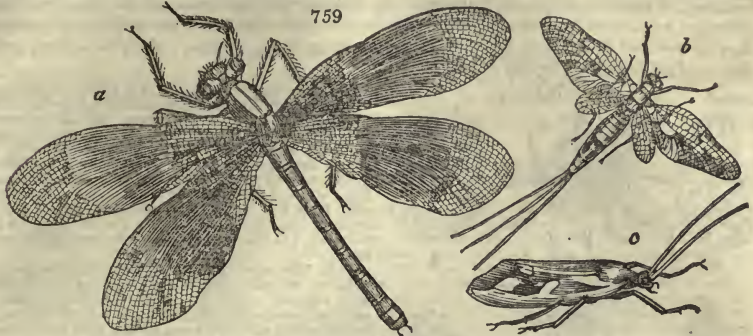

6899. The spring fly (*Phryganea*), in the caterpillar state, lives in the water, and is covered with a silken tube. The caterpillars or larvæ have a very singular aspect; for, by means of a gluten, they attach to the tubes in which they are enclosed small pieces of wood, sand, gravel, leaves of plants, and not unfrequently live on testaceous animals, all of which they drag along with them. They are very commonly found on the leaves of the water-cress; and, as they are often entirely covered with them, they have the appearance of animal plants. They are in great request among fishermen, by whom they are distinguished by the name of stone or cod-bait. The fly, or perfect insect, frequents running water, in which the females deposit their eggs. *P. rhombica* (fig. 759 *c*) is common.

SUBSECT. 6. Of Hymenopterous Insects.

6900. The order *hymenoptera*, or four-winged insects with stings, includes the gall insect, wasp, bee, ant, &c. At the extremity of the abdomen, the females of several of the genera have an aculeus or sting, that lies concealed within the abdomen, which is used as a weapon, and instils into the wound an acrid poison: those which want the sting are furnished with an oviduct that is often serrated, and with which the eggs are deposited, either in the bodies of the caterpillars of other insects, or in wood. From these eggs the larvæ are produced, which in some have no feet, in others more than sixteen. They change to *pupæ incompletæ*, which are enclosed in cases. Some of the insects of this order live in societies, others are solitary.

6901. The gall-fly (*Cynips*) pierces the leaves, &c. of plants with its sting, and deposits its eggs in the wound; the extravasated juices rise round it, and form a gall (fig. 760 *a*) which becomes hard; and in this the larva (*b*) lives and feeds, and changes to a pupa (*c*), and afterwards to the imago or perfect insect (*d*). The *C. quercus folii* (fig. 760 *d*), and *C. glechomatis*, or ground-ivy gall-fly, are very common.

6902. The saw-fly (*Tenthredo*), in the larva state (fig. 760 *e*), bears a strong resemblance to some of the caterpillars of the lepidopterous insects; but is distinguishable by the number of the feet, which are never fewer than sixteen, exclusive of the thoracic pairs; the larvæ feed on the leaves of plants, and the pupa is enclosed in a strong gummy case (*f*), retiring in the autumn, and the perfect fly (*g*) emerges early in the ensuing spring. The serrated sting is used by the female in the manner of a saw, to make incisions in the twigs, or stems of plants, where it deposits its eggs. *T. rosæ* (fig. 760 *e*, *f*, *g*), is a common species. The *T. grosulariæ* (*h*) is also frequent in gardens; both are very troublesome species of this genus.

6903. The *ichneumon* is a very numerous genus, there being upwards of 800 British species. The eggs, in most kinds, are deposited in the bodies of caterpillars or pupæ, which are there hatched: the larvæ have no feet; they are soft and cylindrical, and feed on the substance of the caterpillar; this last continues to feed and even to undergo its change into a chrysalis, but never turns to a perfect insect: when the larvæ of the *ichneumon* are full grown they issue forth, spin themselves a silky web, and change into a pupa incompleta, and in a few days the fly appears. The *I. manifestator* (fig. 760 *h*) is common in woods.

6904. The bee (*Apis*), wasp (*Vespa*), and ant (*Formica*), are well known. All the species of ant are of three sorts, male, female, and neuter. The neuters alone labor; they form the ant-hill, bring in the provisions, feed the young, bring them to the air during the day, carry them back at night, defend them against attacks, &c. The females are said to be retained merely for laying eggs, and as soon as that is accomplished they are unmercifully discarded. The males and females perish with the first cold; the neuters lie torpid in their nest, and thus nature compensates them by duration, what it denies them in intensity of enjoyment.

SUBSECT. 7. Of Dipterous Insects.

6905. The *diptera*, or two-winged insects, have two wings, and behind or below them two globular bodies, supported on slender pendicles, called *halteres* or *poisers*. At the

mouth they have a proboscis, sometimes contained in a vagina, and sometimes furnished at its sides with two palpi, but no maxilla. Their eyes are reticulated and large. The females, in general, lay eggs, but some are viviparous; the larvæ of the insects of this order are as various in their appearance as the places in which they are bred. In general they do not cast their skins, but change into a pupa state. Flies, strictly so called, gadflies, and gnats belong to this order.

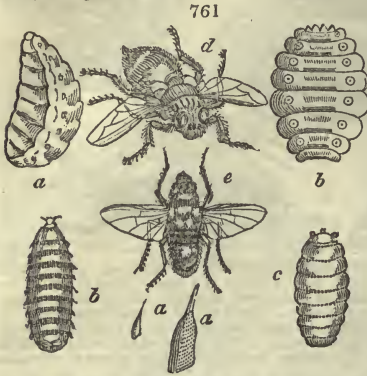

6906. The gad-fly (*Estrus*) is a genus exceedingly troublesome to horses, cattle, and sheep, in the skins of which they deposit their eggs, (fig. 761 a), which soon change into larvæ (b), that feed under the skin of living animals, and often line the stomachs of horses under the name of bots (Clarke, in *Linn. Trans.* vol. iii.); the larvæ are soft, smooth, annulate, without feet, and in most species furnished with hook-like appendages: the chrysalis (c) differs little in form from the larvæ. The *O. bovis* (d) infests oxen; *O. hæmorrhoidalis* (e), horses; and *O. ovis*, sheep.

6907. The crane-fly (*Tipula*) resembles the gnat, it feeds on various substances; the larvæ are without feet, soft and cylindrical; pupa cylindrical, horned; some species reside amongst the roots of aquatic vegetables, others amongst grass, as that well-known pest, the wire-worm; but by far the greater number are aquatic. The perfect flies are found in abundance in the autumnal months. The *T. oleracea*, or long-legs, feeds on the roots of the cabbage; and the *T. crocata* (fig. 762 a) and other species inhabit meadows, and are common from spring to autumn. The wheat-fly (*T. tritici*, b), twelve of which have been observed at one time laying their eggs in a

single ear of wheat, would soon become of serious injury to mankind, were not their race kept within due bounds by several natural enemies, particularly the ichneumon tipula. The well-known gaffer long-legs, so frequently seen in houses in the autumnal evenings, flying about the flame of the candles, and often perishing in the blaze, is the *T. rivosa* (c), one of the largest species of the genus. The eggs of the wheat-fly (d) are very small: when magnified they appear roundish (e); the larvæ also (f), and the perfect insect (b), to be studied, should be magnified (g, h).

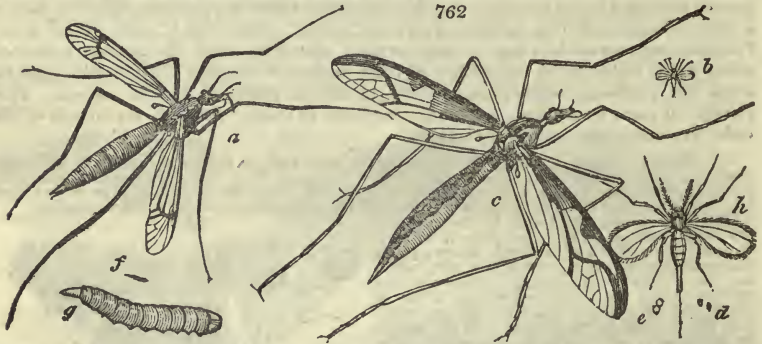

6908. The fly genus (*Musca*) presents many curious species. The common flesh-fly (*M. vomitoria*, fig. 763 a) deposits its eggs on the meat in our shambles and larders. These eggs (b) speedily become larvæ (c) and in a month the fly appears (a). The rapid multiplication of the fly is thus calculated by Leuwenhoeck. "Let us suppose, that in the beginning of June there shall be two flies, a male and a female, and the female shall lay 144 eggs, which eggs, in the beginning of July, shall be changed into flies, one half males and the other half females, each of which females shall lay the like number of eggs; the number of flies will amount to 10,000; and, supposing the generation of them to proceed in like manner another month, their number will then be more than 700,000, all produced from one couple of flies in the space of three months." The Hessian fly (*M. pupilionis*, f) is very destructive to wheat and rye, and has occasionally been a source of great alarm to our agriculturists. The cheese-fly (*M. putris*, g), well known to housewives under the name of hopper, deposits its eggs in the crevices or holes of the cheese, whence those numerous maggots (h), that so much amuse us by their agility and surprising leaps. One of these insects, not a quarter of an inch in length, has been known to leap out of a box six inches deep. The chrysalis (i) is straight and crusty.



6909. The gnat (*Culex*) is frequently in the neighborhood of waters and marshy places. In southern regions there is a large species, which is known by the name of mosquito. Its bite is painful, raising a considerable degree of inflammation, and its continual piping note is exceedingly irksome where it abounds, especially during the night. When it settles to inflict the wound and draw the blood, it raises its hind pair of feet. In Lapland, the injuries the inhabitants sustain from it are amply repaid by the vast number of water-

fowl and wild-fowl which it attracts, as it forms the favorite food of their young. The fecundity of the common gnat (*C. pipiens*, fig. 763 *k*) is as remarkable as that of the flesh-fly.

6910. The *tabanus* genus greatly resembles *musca*, and produces some species troublesome to men and other animals, on whose blood they feed. The *spider-fly* (*Hippobosca*) inhabits woods. The species known as the *forest-fly* (*H. equina*, fig. 763 *l*) is particularly tormenting to the horse.

SUBJECT. 8. *Of Apterous Insects.*

6911. The *aptera*, or insects without wings in both sexes, is composed of genera of such varied forms, that no other general characters can be affixed. Linnæus comprehended in this order spiders, lice, lobsters, crabs, shrimps, &c. which Leach and most other modern naturalists class separately.

6912. The *louse* (*Pediculus*) and *flea* (*Pulex*) are well known: the only genera of this order which are troublesome to the cultivator are the mite-spider (*Acarus*), the common spider (*Aranea*), and the wood-louse (*Oniscus*.)



6913. The *red spider* is the *Acarus telluricus*, L. (fig. 764 *a*), and the same name is also applied by gardeners to the scarlet acarus (*A. holosericeus*, L. *b*), the only two British species of the genus which infest plants, and to which perhaps they do more injury than all other insects put together. Watering over the leaves is the well known preventive and remedy: the water should be applied to both sides of the leaf in a finely divided state, and with great force, so as to dash the insects to the ground. For this purpose Read's syringe is the most efficient implement at present in use. The sheep-tic (*A. reduvius*, *c*), the dog-tic (*A. ricinus*, *d*), the cheese-mite (*A. tiro*), and the itch-mite (*Mite de la gale*, Fr.), (*A. exulcerans*, L.), which inhabits the ulcers of the itch, are the principal species mentioned by Linnæus; but some naturalists consider that every animal, and most plants, have their peculiar species of acarus. The harvest-bug is considered by some an acarus, and by others a phalangium.

6914. The *common spider* (*Aranea*) is a numerous genus, and very prolific: as they live entirely on insects, they cannot be considered as otherwise injurious to the cultivator than by their un-

sightly appearance.

6915. The *wood-louse* (*Oniscus*), is of retired habits, shunning the light and the heat of the sun. It lives on leaves, fruit, and also on animal substances, and casts its crust or skin like the spider. In general it is easily caught by bundles of reeds or beans, or other hollow stalks, like the earwig. The *O. aquaticus* (*e*) is common in springs and clear ponds, or cisterns of water. The dog-tic and water oniscus (*f, g*) both require to be magnified to be studied properly.

SUBJECT. 9. *Operations for subduing Insects.*

6916. The *operations for destroying insect vermin*, or counteracting their injurious effects, are of three kinds, preventives, palliatives, and efficient processes.

6917. The *preventive operations* are those of the best culture in the most extensive sense of the term, including what relates to choice of seed or plant, soil, situation, and climate. If these are carefully attended to, it will seldom happen that any species of insect will exist to an injurious degree. But some parts of culture, such as climate, are often beyond our control; as, for example, when a very dry spring and east wind prevails, in which case many insects increase, or rather their larvæ are hatched and reared under such favorable circumstances that few of them die, and all of them become strong in proportion as the plants on which they live, in consequence of the dry weather (favorable to the insects), become weak. In such a case as this, or its reverse, that of a series of cold moist weather, the agriculturist can do little or nothing.

6918. The *palliative operations* are various. Artificial bad weather will annoy every description of organised being, and especially animals. Excessive waterings, stormy application of water with a syringe, violent wind produced by shaking the plant or tree in the air instead of moving the air round the tree, as in natural wind; these and similar operations will materially injure and annoy insects, both in their common functions and in the work of generation, hatching, and rearing. Insects may be farther annoyed by throwing on them acid waters or powders, as tobacco-water, lime-water, powdered quick-lime, soot, ashes, barley-awns, &c. The smell of tar is particularly offensive to various moths and butterflies; and it is said, if a little of it is placed under plants, or if they are watered with tar-water, these insects will not lay their eggs on them. It is also said that if shreds of flannel are hung on trees or plants, moths and butterflies will lay their eggs on the shreds, in preference to the leaves of the plants. The effect of the fumes of tobacco, sulphur, urine, &c. are well known. Saline substances mixed with water are injurious to most insects with tender skins, as the worm and slug; and hot water, where it can be applied without injuring vegetation, is equally, if not more powerfully, injurious. Water heated to 120 or 130 degrees will not injure plants whose leaves are fully expanded and in some degree hardened; and water at 200 degrees or upwards may be poured over leafless plants.

6919. The *operations for the utter removal or destruction of insects* are few, and chiefly that of hand-picking, or otherwise removing or killing by manual operations with a brush, sponge, or net. Destruction by hand-picking should, if possible, commence with the parent insect in its fly or perfect state before it has deposited its ova. Thus the gathering of moths, butterflies, and large wasps may save the gathering afterwards of thousands of caterpillars and the drowning of hundreds of wasps, as preventing weeds from seeding in a garden will soon eradicate them altogether.

6920. *Catching the winged insect, or hand-picking the eggs, or larvæ*, are the only certain modes of preventing the ravages of the gooseberry caterpillar. As soon as the eggs, which are white, and no thicker than hairs, are deposited and appear on the under side of the leaf, they should be rubbed off, or the entire leaf gathered. It is true, watering the leaves well, and then dusting them with powdered quick-lime, will destroy all those eggs which are wet at the time the lime falls on them: but will it fall on the under sides of the leaves? Watering with lime-water is better; but even that operation is less certain, more troublesome, and not much more expeditious than hand-picking taken in time. In extreme cases, both modes may be combined.

SECT. IV. *Of the Worm Tribes injurious in Agriculture.*

6921. *Of worms* (*Vermes*, L), there are only a few genera which are materially injurious to agriculture, viz. the earth-worm (*Lumbricus*), the slug (*Limax*), and the snail (*Helix*). The wire-worm, so injurious to corn sown on soils newly broken up, and also in gardens, is not a worm, but the larvæ of a species of *Tipula*; commonly of *T. crocata* and *oleracea*. (6907.)

mouth they have a proboscis, sometimes contained in a vagina, and sometimes furnished at its sides with two palpi, but no maxilla. Their eyes are reticulated and large. The females, in general, lay eggs, but some are viviparous; and the larvæ of the insects of this order are as various in their appearance as the places in which they are bred. In general they do not cast their skins, but change into a pupa state. Flies, strictly so called, gad-flies, and gnats belong to this order.

761

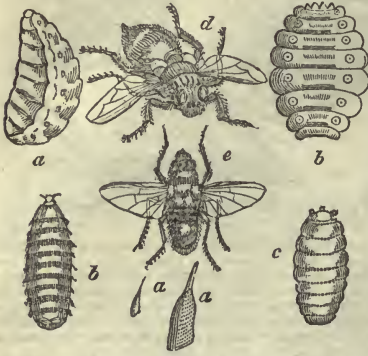

6906. The gad-fly (*Estrus*) is a genus exceedingly troublesome to horses, cattle, and sheep, in the skins of which they deposit their eggs, (fig. 761 a), which soon change into larvæ (b), that feed under the skin of living animals, and often line the stomachs of horses under the name of bots (Clarke, in Linn. Trans. vol. iii.); the larvæ are soft, smooth, annulate, without feet, and in most species furnished with hook-like appendages: the chrysalis (c) differs little in form from the larvæ. The *O. bovis* (d) infests oxen; *O. hæmorrhoidalis* (e), horses; and *O. ovis*, sheep.

6907. The crane-fly (*Tipula*) resembles the gnat, it feeds on various substances; the larvæ are without feet, soft and cylindrical; pupa cylindrical, horned; some species reside amongst the roots of aquatic vegetables, others amongst grass, as that well-known pest, the wire-worm; but by far the greater number are aquatic. The perfect flies are found in abundance in the autumnal months. The *T. oleracea*, or long-legs, feeds on the roots of the cabbage; and the *T. erocato* (fig. 762 a) and other species inhabit meadows, and are common from spring to autumn. The wheat-fly (*T. tritici*, b), twelve of which have been observed at one time laying their eggs in a

single ear of wheat, would soon become of serious injury to mankind, were not their race kept within due bounds by several natural enemies, particularly the ichneumon tipule. The well-known gnat or long-legs, so frequently seen in houses in the autumnal evenings, flying about the flame of the candles, and often perishing in the blaze, is the *T. rivosa* (c), one of the largest species of the genus. The eggs of the wheat-fly (d) are very small: when magnified they appear roundish (e); the larvæ also (f), and the perfect insect (b), to be studied, should be magnified (g, h).

762

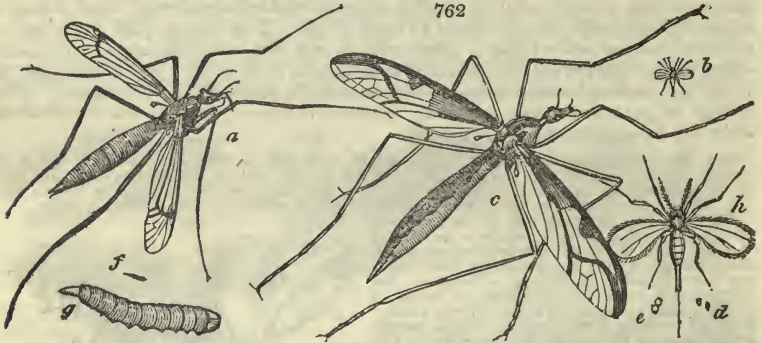

6908. The fly genus (*Musca*) presents many curious species. The common flesh-fly (*M. vomitoria*, fig. 763 a) deposits its eggs on the meat in our shambles and larders. These eggs (b) speedily become larvæ (c) are soon full grown (d), change to the chrysalis state (e), and in a month the fly appears (a). The rapid multiplication of the fly is thus calculated by Leuwenhoeck.

“Let us suppose, that in the beginning of June there shall be two flies, a male and a female, and the female shall lay 144 eggs, which eggs, in the beginning of July, shall be changed into flies, one half males and the other half females, each of which females shall lay the like number of eggs; the number of flies will amount to 10,000: and, supposing the generation of them to proceed in like manner another month, their number will then be more than 700,000, all produced from one couple of flies in the space of three months.” The Hessian fly (*M. pupilionis*, f) is very destructive to wheat and rye, and has occasionally been a source of great alarm to our agriculturists. The cheese-fly (*M. putris*, g), well known to housewives under the name of hopper, deposits its eggs in the crevices or holes of the cheese, whence those numerous maggots (h), that so much amuse us by their agility and surprising leaps. One of these insects, not a quarter of an inch in length, has been known to leap out of a box six inches deep. The chrysalis (i) is straight and crusty.

763



6909. The gnat (*Culex*) is frequently in the neighborhood of waters and marshy places. In southern regions there is a large species, which is known by the name of mosquito. Its bite is painful, raising a considerable degree of inflammation, and its continual piping note is exceedingly irksome where it abounds, especially during the night. When it settles to inflict the wound and draw the blood, it raises its hind pair of feet. In Lapland, the injuries the inhabitants sustain from it are amply repaid by the vast number of water-

fowl and wild-fowl which it attracts, as it forms the favorite food of their young. The fecundity of the common gnat (*C. pipiens*, fig. 763 k) is as remarkable as that of the flesh-fly.

6910. The *tabanus* genus greatly resembles *musca*, and produces some species troublesome to men and other animals, on whose blood they feed. The *spider-fly* (*Hippobosca*) inhabits woods. The species known as the *forest-fly* (*H. equina*, fig. 763 l) is particularly tormenting to the horse.

SUBJECT. 8. *Of Apterous Insects.*

6911. The *aptera*, or insects without wings in both sexes, is composed of genera of such varied forms, that no other general characters can be affixed. Linnæus comprehended in this order spiders, lice, lobsters, crabs, shrimps, &c. which Leach and most other modern naturalists class separately.

6912. The *louse* (*Pediculus*) and *flea* (*Pulex*) are well known: the only genera of this order which are troublesome to the cultivator are the mite-spider (*Acarus*), the common spider (*Aranea*), and the wood-louse (*Oniscus*.)

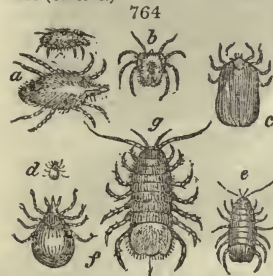

6913. The *red spider* is the *Acarus teluricus*, L. (fig. 764 a), and the same name is also applied by gardeners to the scarlet acarus (*A. holosericeus*, L. b), the only two British species of the genus which infest plants, and to which perhaps they do more injury than all other insects put together. Watering over the leaves is the well known preventive and remedy: the water should be applied to both sides of the leaf in a finely divided state, and with great force, so as to dash the insects to the ground. For this purpose Read's syringe is the most efficient implement at present in use. The sheep-tic (*A. reduvius*, c), the dog-tic (*A. ricinus*, d), the cheese-mite (*A. siro*), and the itch-mite (*Mite de la gale*, Fr.), (*A. erulcerans*, L.), which inhabits the ulcers of the itch, are the principal species mentioned by Linnæus; but some naturalists consider that every animal, and most plants, have their peculiar species of acarus. The harvest-bug is considered by some an acarus, and by others a phalangium.

6914. The *common spider* (*Aranea*) is a numerous genus, and very prolific: as they live entirely on insects, they cannot be considered as otherwise injurious to the cultivator than by their un-

sightly appearance.

6915. The *wood-louse* (*Oniscus*), is of retired habits, shunning the light and the heat of the sun. It lives on leaves, fruit, and also on animal substances, and casts its crust or skin like the spider. In general it is easily caught by bundles of reeds or beans, or other hollow stalks, like the earwig. The *O. aquaticus* (e) is common in springs and clear ponds, or cisterns of water. The dog-tic and water oniscus (f, g) both require to be magnified to be studied properly.

SUBJECT. 9. *Operations for subduing Insects.*

6916. The *operations for destroying insect vermin*, or counteracting their injurious effects, are of three kinds, preventives, palliatives, and efficient processes.

6917. The *preventive operations* are those of the best culture in the most extensive sense of the term, including what relates to choice of seed or plant, soil, situation, and climate. If these are carefully attended to, it will seldom happen that any species of insect will exist to an injurious degree. But some parts of culture, such as climate, are often beyond our control; as, for example, when a very dry spring and east wind prevails, in which case many insects increase, or rather their larvæ are hatched and reared under such favorable circumstances that few of them die, and all of them become strong in proportion as the plants on which they live, in consequence of the dry weather (favorable to the insects), become weak. In such a case as this, or its reverse, that of a series of cold moist weather, the agriculturist can do little or nothing.

6918. The *palliative operations* are various. Artificial bad weather will annoy every description of organised being, and especially animals. Excessive waterings, stormy application of water with a syringe, violent wind produced by shaking the plant or tree in the air instead of moving the air round the tree, as in natural wind; these and similar operations will materially injure and annoy insects, both in their common functions and in the work of generation, hatching, and rearing. Insects may be farther annoyed by throwing on them acid waters or powders, as tobacco-water, lime-water, powdered quick-lime, soot, ashes, barley-awns, &c. The smell of tar is particularly offensive to various moths and butterflies; and it is said, if a little of it is placed under plants, or if they are watered with tar-water, these insects will not lay their eggs on them. It is also said that if shreds of flannel are hung on trees or plants, moths and butterflies will lay their eggs on the shreds, in preference to the leaves of the plants. The effect of the fumes of tobacco, sulphur, urine, &c. are well known. Saline substances mixed with water are injurious to most insects with tender skins, as the worm and slug; and hot water, where it can be applied without injuring vegetation, is equally, if not more powerfully, injurious. Water heated to 120 or 130 degrees will not injure plants whose leaves are fully expanded and in some degree hardened; and water at 200 degrees or upwards may be poured over leafless plants.

6919. The *operations for the utter removal or destruction of insects* are few, and chiefly that of hand-picking, or otherwise removing or killing by manual operations with a brush, sponge, or net. Destruction by hand-picking should, if possible, commence with the parent insect in its fly or perfect state before it has deposited its ova. Thus the gathering of moths, butterflies, and large wasps may save the gathering afterwards of thousands of caterpillars and the drowning of hundreds of wasps, as preventing weeds from seeding in a garden will soon eradicate them altogether.

6920. *Catching the winged insect, or hand-picking the eggs, or larvæ*, are the only certain modes of preventing the ravages of the gooseberry caterpillar. As soon as the eggs, which are white, and no thicker than hairs, are deposited and appear on the under side of the leaf, they should be rubbed off, or the entire leaf gathered. It is true, watering the leaves well, and then dusting them with powdered quick-lime, will destroy all those eggs which are wet at the time the lime falls on them: but will it fall on the under sides of the leaves? Watering with lime-water is better; but even that operation is less certain, more troublesome, and not much more expeditious than hand-picking taken in time. In extreme cases, both modes may be combined.

SECT. IV. *Of the Worm Tribes injurious in Agriculture.*

6921. *Of worms* (*Vermes*, L), there are only a few genera which are materially injurious to agriculture, viz. the earth-worm (*Lumbricus*), the slug (*Limax*), and the snail (*Helix*). The wire-worm, so injurious to corn sown on soils newly broken up, and also in gardens, is not a worm, but the larvæ of a species of *Tipula*; commonly of *T. crocata* and *oleracea*. (6907.)

6922. *The slug (Limax)* is without a shell, and distinguished by its lateral pore. There are sixteen British species; the *L. ater* (fig. 765 *b*), *alba*, and *hyalinus* are the most common in gardens; and the *L. agrestis* (*a*) is common both in gardens and fields, and is the species recommended to be swallowed by consumptive persons. The snail (*Helix*) is a numerous genus, and, like the slug, very destructive to plants and fruit: both snails and slugs are hermaphrodite, having both sexes united in each individual; they lay their eggs with great care in the earth, and the young ones are hatched, the slugs without shells, and the snails with shells completely formed. They are most troublesome in spring and autumn, and during mild weather in winter. In dry warm weather, and during frosts, they retire into the earth and remain there in a torpid state. The most common species is the *H. hortensis* (fig. 765 *c*), or garden-snail,

765

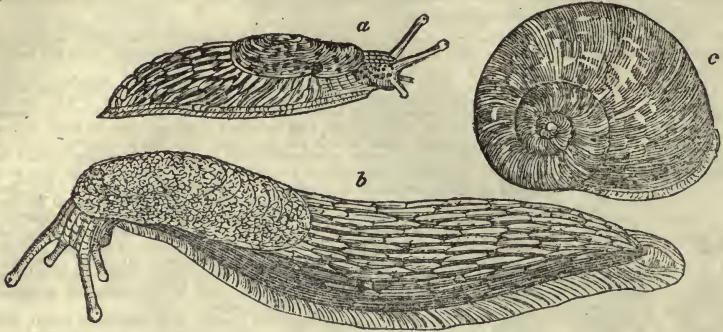

of which it is remarked, that having once attacked a leaf or fruit, it will not begin on another till the first is wholly eaten. Snails, slugs, and worms, may be annoyed by caustic substances scattered over them, or by watering with bitter infusions, acids or alkalis, as vinegar, or what is equally effectual and cheaper, lime-water; but the only effectual way of getting rid of snails is by hand-picking. They may be collected under decaying leaves or haulm, laid down on purpose to attract them. In this way, as we have seen (4916.), a whole field may soon, and at little trouble and expense, be effectually cleared of this class of enemies.

---

## PART IV.

### STATISTICS OF BRITISH AGRICULTURE.

6923. After having considered agriculture as to its history, as to the scientific principles on which it is founded, and the application of these principles to the different branches of practice; it remains only to take a *statistical survey and estimate* of its present state and future progress in the British isles.

---

## BOOK I.

### OF THE PRESENT STATE OF AGRICULTURE IN THE BRITISH ISLES.

6924. *The present state of British Agriculture*, as to knowledge and the details of practice, has been the subject of the former PARTS of this work; but its importance in the general economy of society, can only be learned by a view of the manner in which it is actually carried on; the modifications to which it has given rise in the pursuits of those who have embraced the art as a source of livelihood; of the kinds of farms cultivated by different orders of agriculturists; of the principal practices of each of the different counties of Britain and Ireland as to agriculture; of the British authors who have written on the subject; and of the professional police and public laws relative to husbandmen and agriculture.

---

## CHAP. I.

*Of the different Descriptions of Men engaged in the Practice or Pursuit of Agriculture.*

6925. *Agriculturists* may be arranged as *operators* or *servant agriculturists*; *dealers* or *commercial agriculturists*, *counsellors*, *professors* or *artists*; and *patrons*.



SECT. I. *Of Operators or serving Agriculturists.*

6926. The lowest grade in the scale of this class is *farm laborers*, who may be either men, women, or children; and either local residents, periodical visitants for particular labors, as hay-making, reaping, &c., or itinerant workmen for taking jobs, as ditching, stocking, &c. None of this class of operators are supposed to have received any other professional instruction than what they have derived casually, or from observing others.

6927. *Apprentices* are little known in agriculture; but they occur sometimes, either as the children of other operators, whose parents bind them a certain number of years, during which they are to work for their food and clothes, and 5*l.* or 10*l.* to be received at the end of the term according to conduct; or sons of richer persons, who pay a premium for the instruction to be received, and for boarding with the master. The former class of apprentices generally look forward to being ploughmen, shepherds, head ploughmen, or inferior bailiffs; the latter to being first bailiffs, stewards of estates, or to farming on their own account. Parish boys are sometimes bound apprentices of the first class, and various noblemen's sons from almost every kingdom of Europe have been included in the second.

6928. The term *journeyman* is as little known in agriculture as apprentice. Those who answer to that term are the professional operators of a farm, such as ploughmen, cattle herds, shepherds, and hedgers. These rank decidedly above laborers of all work. A ploughman may not unaptly be considered as of the rank of an apprentice till he can *fear* or set out ridges, and after he can do this as of the rank of journeyman till he can stack and sow. He may then be considered as a master of his art, entitled to work the best pair of horses, and if twenty-five or thirty years of age, to enter into the marriage state.

6929. A *hedger* is a professional operator, who may be considered as ranking with a master ploughman. His business is to plant, clean, prune, cut, lay, plash, and repair hedges; prune forest and orchard trees, and effect other operations with ligneous plants on the farm. In Berwickshire hedgers are generally very intelligent men, and keep the fences on the farms in the border counties in excellent order, and the hedge-row trees handsomely pruned.

6930. A *woodman* is an operator employed to prune trees and manage hedges, and is of the same rank and requires the same kind and degree of professional knowledge as the hedger. Generally he is more conversant with barking trees for the tanners, converting copsewood and measuring timber than the other, being more engaged with woods than hedges.

6931. A *head ploughman*, on small farms, is to be considered as the bailiff in the absence of the master. He works the best pair of horses, and assists the master in stacking and sowing. On larger farms, where a regular bailiff is kept, there is also a head ploughman, who acts as substitute for the bailiff in his temporary absence, as far as operatives and overlooking operations; but not in money matters or contracts.

6932. A *farm bailiff* is, or should be, a person of tolerable education, who understands accounts, measuring of work, land, and timber, and can draw up agreements for hiring servants. He should have practised every part of farming himself, from tending poultry, swine, and sheep, to stacking and sowing. When employed by a gentleman, or one who has no skill in farming, he should not be under twenty-five years of age; but a farmer's bailiff need not exceed twenty-one years, is to be considered as a sort of apprentice, and will be directed in all leading matters by his master.

6933. A *bailiff and gardener*, or *gardener and griever*, as they are called in some places, is a sort of hybrid upper servant, who seldom excels either as a farmer or a gardener, and is only fit for situations of limited extent, and an indifferent style of performance.

6934. The *forester* or head woodman is to the woods of an estate what the bailiff is to the farm lands in hand. He directs and superintends the woodmen and their laborers, in planting, rearing, and pruning plantations, and in the felling of timber or copse, barking, charcoal making, and in short every thing connected with timber, trees, copses, or hedges.

6935. The *land steward* (*Factor*, Scotch; *Facteur*, Fr.; *Factor*, Ger. and *Fattore*, Ital.), is to a whole estate what a bailiff is to the demesne or a particular farm. His business is to control the managers of the lands in hand, as the forester, gardener, bailiff, &c.; to see that farmers fulfil the covenants of their leases; to attend to repairs, roads, public and parochial matters in behalf of the landlord, and generally to receive rents.

6936. *Under stewards*, or steward's bailiffs, as they are called, are assistants to the main steward, or have the care of detached estates, containing a few farms or woods.

6937. *Demesne stewards*, are such as are kept chiefly for regulating the affairs of demesne lands, that is, lands surrounding the mansion in hand, or of an estate of small size, where all the lands are in hand, but where an extensive establishment of horses, servants, a large garden, &c. are kept up. Here the steward performs the duties of bailiff, forester, and in some degree of house-steward, by his connection with the stables and game-keeper, and other domestic rural matters.

6938. *Court farmer*, (*Hoffmeyer*, Ger.; *Grangero de la corte*, Span.; *Agronome de la cour*, Fr.; and *Fattore della corte*, Ital.), may be considered the highest step, the *summum bonum* of agricultural servitude. The late Ramsay Robinson, Esq. was bailiff to Geo. III.; his sister, Miss Robinson, was royal dairy-woman; and Sir Joseph Banks, royal shepherd.

#### SECT. II. *Commercial Agriculturists.*

6939. The first grade here is the *jobbing farmer*, who keeps a team, a cart, plough, pair of harrows, and probably one or two hand implements. He hires himself by the day, week, or by the acre to plough, sow, or labor the small spots of ground of tradesmen who keep a cow but no laboring stock; or to assist farmers who are behind with their labors. The contractors for executing works devised by the agricultural engineer (6969.), though widely separated in point of wealth from the common jobber, yet belong to the same species; both agree in selling their labor and skill in a raw state, not when manufactured into produce like the other commercial agriculturist.

6940. *Itinerant agriculturists* are of two kinds; such as take grounds for the culture of one or two crops of particular sorts of plants, as woad, flax, &c. (5364.); and such as travel with a plough and pair, &c. to teach that operation to young farmers, or their servants, a practice at one time carried on in Ireland under the patronage of the Dublin Society.

6941. *Cottage farmers* are such as possess a cottage and an acre or two of land, which they may either keep in aration or pasture; disposing of the corn, green crops, or dairy produce in various ways, according to local circumstances.

6942. *Poultry farmers*, such as devote themselves chiefly to the breeding, rearing, and fattening of poultry, and the growing of feathers and quills.

6943. *Garden farmers* are such as possess lands near large towns, or sea-ports, and grow the commoner garden vegetables, as pease, onions, cabbages, &c. for the market; or herbs for the distillers and druggists.

6944. *Seed farmers*. Small farmers who devote themselves chiefly to the growing of garden seeds for the London seedsmen, and for the distillery. They are to be found only in a few counties in the central and southern districts of England, and chiefly in Kent and Essex. (See *Encyc. of Gard.* 2d edit. 7390.)

6945. *Orchard farmers* are such as farm grass or arable orchards, sometimes joined to hop lands and garden farms; often with a small dairy; with rearing of poultry, rabbits, &c., and sometimes with the breeding and training of dogs; the latter a very lucrative branch when well understood.

6946. *Hop farmers*, such as make hops a principal article of cultivation, to which are sometimes joined garden and orchard farming.

6947. *Milk or cow farmers*, such as keep cows for selling their milk in an unmanufactured state. These farmers are of course limited to populous neighborhoods. Cow-keepers differ from cow-farmers, in having their establishments in towns, and in purchasing, not growing, their cow provender.

6948. *Dairy farmers*, such as keep cows and manufacture their milk into butter or cheese. These are most common in rich moist flat districts, as Cheshire, part of Gloucestershire, Leicestershire, &c.

6949. *Graziers*, farmers whose chief business consists in buying, feeding, and selling cattle and sheep. Their farms are chiefly in old pasture, and they are more commonly feeders than breeders. The most extensive in England are in Leicestershire and Lincolnshire.

6950. *Stock farmers*, such as devote themselves to breeding and rearing different kinds of live stock, especially horses and cattle. They are most common in Yorkshire.

6951. *Store farmers*, breeders who devote themselves chiefly to the sheep and cattle families. They are common in the border counties, in Wales, and in the Highlands.

6952. *Hay farmers* are confined to a small district round London; where they grow chiefly natural or meadow hay for the London coach and saddle horses, and for cow-keepers.

6953. *Corn-farmers*, as opposed to hay, dairy, grazing, and breeding farmers, is a term employed to such as occupy lands more adapted for the plough than for pasturage, as arable clays and loams.

6954. *Wood-farmers*, such as rent woodlands, to be periodically cut for fuel, bark, fence-wood, charcoal, or other purposes.

6955. *Quarry-farmers*, such as rent quarries of lime or other stone, gravel-pits, clay-fields, marle-pits, &c.

6956. *Mine-farmers*, or master miners or mine-holders, such as rent coal-mines, or mines of iron, lead, or other metals.

6957. *Salmon or river-farmers*, or fishery renters, such as rent rivers or ponds for the sake of their fish.

6958. *Commercial or professional farmers*, such as farm lands for profit. Those who farm an extent of good land under one hundred acres, are considered small farmers; under three hundred acres, middling farmers; above and under five hundred acres, large farmers; and exceeding that quantity, extensive farmers: a very proper title, for few arable lands can be profitably cultivated to a greater extent in one farm or by one establishment than five hundred acres, and those which exceed that quantity, are generally breeding or other stock farms, characterised by their extent.

6959. *Gentlemen farmers*, are professional farmers on a large scale, who do not associate with their minor and personally working brethren; but who affect in their style of living the habits and manners of independent men or gentlemen. It is a character extremely liable to ridicule by the vulgar yeoman and purse-proud farmer on the one hand, and those persons who are gentlemen by profession, and men of family on the other.

6960. *Yeomen farmers*, small proprietors who farm their own lands, but yet aspire not to the manners and habits of gentlemen.

6961. *Farming landlords*, proprietors who farm their own lands on a large scale.

### SECT. III. *Agricultural Counsellors, Artists, or Professors.*

6962. *The land-measurer* is the lowest grade of agricultural artists; he is very often the village schoolmaster, and is called in to measure work done by the job, as mowing, reaping, hedging, trenching, &c.

6963. *The agricultural salesman* is a person who attends at fairs, markets, &c., and acts as agent to buyers and sellers of corn and cattle. There are also salesmen purely for hay and straw, others for green food, turnips, potatoes, &c.

6964. *The appraiser*, or valuer of farming-stock, comes next in order. This professor values the live and dead stock, and crop, tillages, manures, &c., and sometimes also the remainders of leases between outgoing and incoming tenants, or betwixt tenants and their landlords. Occasionally the appraiser is employed to value lands, but this is generally the business of the land-valuer.

6965. *The land-surveyor* generally confines his avocations to the measuring and mapping of lands; or to their subdivision, or the arrangement of fences and other lines; but sometimes he joins the business of appraiser and valuer, and even timber-measurer.

6966. *The timber surveyor and valuer*, confines himself in general to the measurement and valuation of fallen or standing timber; he also measures and estimates the value of bark, faggots, roots, charcoal, ashes, willows, hoops, and various other products of ligneous plants.

6967. *The land-valuer* not only values the rental, but the price or fee-simple of lands, buildings, woods, quarries, and waters. He does not often meddle with metallic or saline mines; but he sometimes values fisheries, stone and lime quarries, brick-earth, gravel, chalk, &c. This profession requires not only a general knowledge of agriculture in the most extensive sense of the word, but a very extensive acquaintance with the country in which the property lies, and great experience in business. There are local and general land-surveyors and land valuers: the general professors live in the capital cities or in the metropolis, and generally unite the business of land-agent.

6968. *The land-agent* may or may not be a land-valuer, but at all events he should possess the knowledge of the valuer in an eminent degree. His business is to effect the transfer of property either by purchase, sale, hiring, or letting; and also to collect rents, and often to relet farms, and effect other business belonging to the land-valuer. Land-agents are very frequently attorneys, who know little of agriculture; but who save their employers the trouble of employing both a land-steward of superior abilities, and a lawyer to draw up agreements and leases. It is the opinion of the best informed agriculturists both of Britain and France, that the employment of attorneys as land-stewards and agents, has been one of the chief causes of the retardation of agriculture throughout Europe. Chateauevieux has clearly shown how this cause has operated in France and Italy, and Dr. Anderson, Arthur Young, Marshal, and various others have deprecated its influence in Britain. The love of precedent, which these men cannot abandon from habit; the love of litigation, to which they adhere from taste and interest; and the ignorance of agriculture, from the nature of their education, are the causes that have counteracted the tendency to change and amelioration.

6969. Of *agricultural engineers* there are considerable variety. *The drainer* for laying out drains and water-works; *the irrigator*, for watering the surface of grass-lands; *the road engineer*, for laying out roads; *the mineral surveyor*, for searching for, measuring, mapping, and valuing mines and minerals; *the coal viewer*, for estimating the value of coal works; *the rural architect*, for designing and superintending the execution of agricultural buildings, and the *hydrographical and canal engineers*, for canals, harbors, mills, and the greater water-works.

6970. *The veterinary surgeon*, or agricultural doctor, is to be considered as a rural

professor; and as subordinate grades, may be enumerated the farrier, (*Ferrier*, Fr.; *Ferrajo*, Ital. a smith, from *ferrum*, L. iron.), cowleech, and castrator or gelder.

6971. *The agricultural draftsman*, or artist by way of eminence, is employed in designing and painting live-stock, implements, plants, and cultivated scenery; the plans of farms are taken by the land-surveyor, designs of buildings made by the architect, and new inventions in machinery and implements are drawn by the inventors, whether millwrights or agricultural mechanists.

6972. *The agricultural author* may be considered as the most universal kind of agricultural counsellor, since his province includes every branch of the art, and comprehends times and practices past, present, and to come. The simplest variety of this species is the author of single papers in magazines, or the transactions of societies; the most extensive, he who embraces the whole of the subject; and the most valuable, he who communicates original information.

6973. *The professor of agricultural science* (*Professeur d'Agriculture ou d'Economie Rural*, Fr.; *Hochlehrer von Ackerbau*, or *H. von Land Wirtschaft*, Ger.; *Profesor d'Agricultura*, Span.; and *Professore d'Agricoltura*, Ital.), when appointed by a permanent or national institution, may be reckoned the highest grade of agricultural counsellor: since he is not a self-constituted instructor, like the author; but constituted by competent judges as capable of instructing the public. The first public professor of agriculture appointed in Britain was Dr. Coventry of the University of Edinburgh, about 1790; and the next Sir Humphrey Davy, Lecturer on Agricultural Chemistry to the Board of Agriculture, about 1807: both highly eminent as agricultural counsellors, independently of their other merits. There are agricultural professors in Dublin and Cork. In almost every University on the continent there is an agricultural chair, and in some of the German and Russian Colleges there are chairs for gardening (*Gärtnercy*), forest-culture (*Forstwissenschaft*), and rural architecture (*Land Baukunst*).

#### SECT. IV. *Patrons of Agriculture.*

6974. Every man being a *consumer* of some description of agricultural produce, may be considered a promoter of the art by causing a demand for its productions. The more valuable consumers are such as live on the best bread, butcher's meat, fowls, and dairy products; and the greatest of all patrons, both of agriculture and gardening, are such as fare sumptuously every day.

6975. *Amateur agriculturists*, lovers of agriculture, promote the art by the applause they bestow on its productions; of which, to a certain extent, they become purchasers, as of farming books, prints of cattle, implements, &c.

6976. *Connoisseurs*, critical or skilful lovers of agriculture, promote the art in the same way as the amateur, but much more powerfully, in proportion as approbation founded on knowledge is valued before that which arises chiefly from spontaneous affection. By the purchase of books, models, attendance at agricultural exhibitions, &c., connoisseurs encourage both counsellors and commercial agriculturists. Sometimes, also, by their writings, of which Sir John Sinclair is an eminent example.

6977. *Employers* of agriculturists, whether of the serving class, as bailiffs, stewards, &c., or of the order of professors or artists, are obvious encouragers of the art.

6978. *Amateur farmers* are patrons on the same principle as employers; and sometimes, also, they effect improvements, or communicate valuable information to the public. Cline, the eminent surgeon, and Dr. Parry, the physician, are eminent examples.

6979. *Noblemen and proprietor farmers* are conspicuous patrons. They render the art fashionable, and by the general attention so directed, and consequent occupation of many minds on the same subject, new ideas are elicited, and dormant talents called forth and employed. Russel, Coke, Curwen, and Somerville, stand preeminent among this species of patrons, and many others might be added.

6980. *Noblemen and gentlemen improvers*, whether by planting, building, road-making, establishing villages, canals, harbors, &c. are evidently greater patrons of agriculture than noblemen farmers, since their improvements affect society more extensively. As decidedly at the head of this species of patron may be mentioned the late Duke of Bridgewater and the present Marquess of Stafford, and to these names might be added a number of others.

## CHAP. II.

*Of the different Kinds of Farms in Britain relatively to the different Classes of Society who are the Occupiers.*

6981. *Cottage farms* form the first link in the chain of temporary terrestrial possessions. They consist of one or more acres appended to a cottage, for the purpose of enabling the occupier to keep a cow; if any part of this farm is in aration, the labor is either hired of some jobbing agriculturist, or done by spade; or two or more cottagers join together and form a team of their cows, with which, and implements borrowed from the village-carpenter or smith, they accomplish their labor.

6982. *Farms of working mechanics.* These are larger than the former, and are rented by country blacksmiths, carpenters, &c. who often keep a horse or a pair of horses. Both this and the former sort are very often injurious to the occupiers, by drawing off their attention from their principal source of income; though it must be confessed at the same time, that the idea of occupying land, and raising one's own corn, clover, milk, butter, eggs, pulse, &c. is highly gratifying; gives a sort of sense of property, and has an air of independence and liberty, highly valued by men in general.

6983. *Farms of village tradesmen and shopkeepers.* Many of these men, such as bakers, butchers, grocers, &c. keep a horse at any rate; by renting a few acres they are able to keep another, and add a cow, and other minor species of live stock. The attention required from the master forms a healthful recreation, and agreeable variety of pursuit; and if this recreation does not interfere with main pursuits, there is a gain of health and respectability.

6984. *Farms occupied with a view to profit by town and city tradesmen.* These are on a larger scale than the last, and held by stable-keepers, cow-keepers, butchers, corn-dealers, &c. They are often of considerable size, mostly under grass, and managed by bailiffs. Arable farms in such hands are rarely well managed, as every thing is made to depend on manure; but as less skill and vigilance is required in managing grass lands, hay or pasture farms of this description are generally well manured, and consequently productive. They are seldom however profitable, and it is only because the renter reaps the double profit of grower and consumer, has some enjoyment in the idea of the thing, and some increase of health from the requisite visits to it, that he finds it suitable to continue his farming operations.

6985. *Farms occupied by city tradesmen for recreative enjoyment.* These are of various descriptions, and generally managed by bailiffs. They may be considered as affording recompence by the amusement, exercise, and health which they afford, and the interest in country matters which they excite. Many a worthy man thus throws away, almost at random, on agriculture, what he has gained by trade with the greatest industry, and frugality, often joined to skill and ingenuity. When the farm promises well, the tradesman is sometimes tempted to sell his trade and turn farmer for good (as it is called, *i. e.* for a principal occupation), and often ends in impoverishing, or even ruining himself.

6986. *Farms attached to the villas and country houses of wealthy citizens.* On these the wealthy citizen plays at agriculture, aided by a skilful manager or bailiff. Immense sums of money are thus expended in the neighborhood of large towns; many ingenious practices are displayed; and though nothing in the way of profit is ever expected to be gained; yet on the whole an attention to agriculture is excited in the minds of wealthy commercialists, who buy books on the subject, procure bailiffs, approved implements and breeds of stock; and thus give encouragement to these and other productions connected with the subject. The history of farming for the last twenty years round Edinburgh, Liverpool, and London, affords some curious, singular, and extravagant examples of this description of farming, and some of a much more judicious description.

6987. *Demesne farms,* or such as are occupied by the landed proprietors of the country. These are of a great many different kinds; some regularly appended to the park; some comprising a part of the park separated by temporary fences; and others taken into occupation without regard to situation. Some proprietors take all the farms on their estate successively into their own hands, cultivate them for a few years, bring them into excellent order, and then let them to farmers. Much good is often done by proprietors occupying land themselves; new practices, and new kinds of vegetables and live stock, exhibited and disseminated; and the landlord himself being instructed by experience in the practice of farming, is better able to judge what his land should let for; and more likely to appreciate good tenants, and sympathise with the losses of his farmers in bad seasons. Add also, that a proprietor in this way procures better butcher meat of every kind than he could generally purchase in the neighboring markets; and, if he chooses, better legumes and roots, and even better cabbages and other culinary vegetables than he could grow in his kitchen garden. The bailiffs on such farms are, or ought to be, well educated men, brought up to farming in the best districts. They should be well paid, and have

sub-bailiffs under them. The establishments of Bedford, Coke, Curwen, Albemarle, &c. are among the most complete in this kind of farming.

6988. *The farms of professional farmers.* It must be obvious, that this class includes more than nine-tenths of all the farms in the country. They are of every description of soil, climate, situation, &c. which the country affords; of all manner of sizes, according to the demand created by such as follow farming as a business, and either devoted to the general purposes of corn and cattle, or more particularly for poultry, milking, dairying, garden crops, hops, orchard crops, grazing, breeding, hay, corn, wood, minerals, as stone quarries, &c., or fishes. At the origin of what we now call farming, or when the hiring of land by cultivators succeeded to cultivating them for the landlords, or in partnership with the landlords, as is still the case in Italy and most other countries, farms would of course be small, and farmers men of scarcely any capital or consideration in society. Just emancipated from a state of bondage and villanage, the new created independent tenant could not easily throw off the chains which formerly shackled his mind and prevented his energies from being brought into action, and he could have little or no property when he had no means of acquiring it but by plunder, or preserving it but by concealment. Hence the first tenants were assisted by their landlords, and one remnant of this practice, that of allowing farmers to have a year's rent always in hand; or, in other words, not to demand the rent till half or a whole year after it is due, still exists in some parts of Scotland and Ireland. In process of time, however, and from various direct and indirect causes, farmers at length acquired some degree of capital and respectability; and as they naturally thought of employing the former, of course farms began to be enlarged to afford scope, and leases granted to afford security. This practice has been going on in Britain for more than two centuries past, and receives a fresh impulse whenever the prices of grain rise high, and continue so for some time. At no period have they been so high as about the commencement of the present century, and during no period have the riches and respectability of farmers so much increased. More recent political changes, however, have proved singularly disastrous to farmers; and till the corn laws are either obliterated, or regulated on some permanent and more moderate principle, agriculture and its practisers of every description will remain liable to the extremes of profitable occupation and ruin.

### CHAP. III.

#### *Topographical Survey of the British Isles in respect to Agriculture.*

6989. The *British isles*, as we have already observed (1254.), are in their present state, naturally and politically more favorable to the practice of the agriculture of ale, butcher meat, and wheat, than any other country in the world. They have their disadvantages both in climate and in civil and political matters; but, notwithstanding, there is no country in the world where farmers or proprietors are so respectable a class of men, and where such excellent corn, herbage, roots, and hay, either raw, or in their manufactured state of bread, ale, and butcher meat, is brought to market.

6990. The following *outline of the state of agriculture in each of the different counties of the united kingdom* is taken from the *Surveys* published under the authority of the Board of Agriculture, or the Dublin Society; from Marshal's remarks on these surveys, and his other writings; and in some cases, from our own observation; having at various periods, since the year 1805, been in almost every county in Britain, and in most of those in Ireland. Agricultural improvement is often of so variable and fleeting a nature, that notwithstanding our utmost care, some things may be found here inserted as such, that no longer exist; and from the period, varying from 12 to 20 years, which has elapsed since the surveys were published, many improvements may have been made deserving of insertion which are omitted. These are unavoidable defects attendant on this part of our work; but though we cannot render it perfect, yet we are of opinion we can bring together a sufficient number of facts as to the natural and agricultural circumstances of each county, as to render it both interesting and useful to the reader.

#### SECT. I. *Agricultural Survey of England.*

6991. The *surface of England* is estimated at 32,150,000 acres, almost every where cultivated, and no where incapable of cultivation; in most places varied, gently and beautifully in some districts, and abruptly and on a grander scale in others. The most highly and mountainous districts are those of the north, and the most level those of the east. The most humid climates are those of the north-western counties; as Cheshire, Lancashire; and the most dry those of the south-east, as Norfolk and Suffolk. The richest grass lands are in the vales of the great rivers, as the Severn, Trent, and Thames. The richest arable lands, in Worcestershire, Warwickshire, and in part of various other counties; and the best farming, in Northumberland, Durham, and Cumberland. The greatest variety of farming may be seen in the counties round London; and the greatest

sameness, regularity, order, science, success, and the wealthiest farmers in Northumberland. The geology and minerals of the kingdom are most ably indicated in *Smith's Geological Map of England, Wales, and part of Scotland, 1815. Smith's County Geological Maps, 1819 to 1824; and Smith's Geological Table of British Organised Fossils, 1819.* These works are of the greatest importance to landed proprietors.

6092. MIDDLESEX is part of the north side of a vale watered by the Thames, and contains 179,200 acres, exhibiting a great variety of agriculture. (*Middleton's Survey, 1806. Marshal's Review, 1818.*)

### 1. Geographical State and Circumstances.

*Climate.* Healthy; warmer near London, from the fires kept there, which consume 800,000 chaldrons of coals annually; stationary winds from the S. W. and N. E. those from the S. W. blow 6-12ths of the year, N. E. 8-12ths. Greatest falls of rain from a few points W. of S. and are of the longer continuance when the wind has passed through the east to the south. In spring, frost in the hollows, when none on the hills, thermometer has been as high as 85°, and as low as 6° below zero.

*Soil.* By long continued manuring, the surface soil almost everywhere looks like loam. Sand and gravel on Hampstead Hill. Loamy sand from Hounslow to Colnbrook. Sandy loam on west side of Hanwell and Hounslow. Strong loam about Epsom, Esher, Harrow, and South Mimms; loamy clay between Uxbridge and Harfield. Clay of the most adhesive and ungrateful kind about Hendon and Highwood Hill; peat from Rickmansworth to Staines, on a substratum of the gravel of flints. Marsh land or rich loam deposited from still water in the Isle of Dogs and on the Lea and Coln.

*Surface.* Gently waving; highest towards the north. Hampstead 490 feet above the level of the sea. One mile from London on the Kingland Road, the surface of upwards of 1000 acres is lowered at an average five feet from the brick earth dug out, which of ordinary quality has produced 4000l. per acre; and when marly, for malms or white bricks, 20,000l. per acre. Brick earth formerly 100l. per acre, now 500l. per acre.

An acre at four feet deep, yields four millions of bricks. *Mineral waters.* 1. Caltrop surface. 2. Gravel. 3. Flints, 5 or 10 feet in thickness. 3. Lead or blue clay, 200 or 300 feet in depth. 4. Marine sediment, 3 or 4 feet in depth. 5. Loose sand, gravel, and water, the latter arising in such quantities as to prevent digging deeper.

*Water.* Abundant and excellent. The Thames, from Oxford to Maidenhead, falls about 24 feet in ten miles; from Maidenhead to Chertsey Bridge, 19 feet in ten miles; thence to Mortlake, 13 feet per ten miles; and to London, one foot per mile; from London the fall diminishes till it is lost in the sea. Tide flows twenty-three miles up the Thames. Spring water found at various depths, from 5 to 300 feet; the latter, the depth of Faddington.

*Mineral waters* at East Acton, Hampstead, and Bagnigge-wells: chalybeates little used.

*Fish caught in the Thames.* Sturgeon, salmon, tench, barbel, roach, dace, chub, bream, gudgeon, ruffe, bleak, eels, smelts, and founders.

### 2. State of Property.

*Estates and their management.* Generally under the care of aristocrats, and badly managed.

*Tenures.* Much freehold, considerable extent of copyhold, some church, college, and corporation land.

### 3. Buildings.

*Farms of proprietors.* Numerous, splendid, commodious.

*Farm-houses, offices, repairs.* Oldest built with timber lathed and plastered, roofs thatched; erected piecemeal; situated in villages, sides of lanes, and near large ponds. Those built within the present century, of brick, and covered with tiles. Farmery of Sutton Court, Chiswick, Molegreen, and Isleworth, models of their kind. Very few buildings required on hay farms.

*Cottages,* brick and tiled, and generally in villages; formerly with right of common, now done away by enclosures.

### 4. Mode of Occupation.

*Size of farms.* Generally small compared with other counties; three cow-farms near town, from 500 to 600 acres each, rented at from 2 to 5000l. each. Many of 200l.; average of cost 100l.

*Character of the farmers.* Four classes. 1. Cow keepers, gardeners, and nurserymen. 2. Amateur farmers of fortune. 3. Amateur farmers, who have left other pursuits. 4. Commercial or professional farmers, equal in number to half the others.

*Rural artificers.* Bad; impossible to get any agricultural implement or machine made to good principle by the country artificers; but able mechanics in London; Maccouald, Cook, Snowden, and especially Weir, a Northumberland man, and practically acquainted with agriculture.

*Rent paid in money,* sometimes a small part in butter and cream at fixed prices. Varies from 10s. to 10l. per acre, or higher for nurseries.

*Rent paid in kind,* in some places taken in kind, in some compounded for annually, or for a fixed period.

*Poor, and the rates for their relief,* average 3s. 6d. per acre. *Leases,* general. Often for fourteen and twenty-one years drawn up by lawyers—"a composition of obsolete unintelligible covenants."

*Expenses and profit.* Expenses on entering a farm, greater than in distant places; profits seldom more than a mere subsistence to the farmer.

### 5. Implements.

All bad; plough barbarous; threshing mills rare.

### 6. Enclosures.

Now mostly enclosed. Nineteen commons enclosed from 1800 to 1806, containing 20,000 acres and upwards. Old fences of a mixture of white and black thorn, maple, hazel, birch crab, damson-plum, &c.; new of white thorn with ditch

and bank; gates mostly five-barred, and of oak; enclosures too numerous.

### 7. Arable Land.

About 14,000 acres; wretchedly managed, ploughed with teams of three or four horses; rotation generally fallow, wheat, beans.

### 8. Grass Lands.

Meadows better managed; hay-making good.

### 9. Gardens and Orchards.

From Kensington through Hammersmith, Chiswick, Brentford, Isleworth, and Twickenham, seven miles of garden ground; may be denominated the great London fruit garden, north of the Thames. An upper and under crop taken at the same time; in the upper the fruits on trees; in the under strawberries and various herbaceous crops. To increase shelter and warmth in autumn, they raise banks of soil 3 feet high, facing the south, and sloped to an angle of 45°; on these they plant endive in September, and near the bottom, from October to Christmas, they drill a row of pease; the endive is preserved from rotting, and the pease come to maturity nearly as early as if under a wall. The springs here, lie eight or ten feet under the surface, and the water is raised from the wells by a bucket and lever, balanced by a stone. (*fig. 157.*) Three thousand acres of garden ground here, employing five persons, a man, his wife, and three children, per acre, during the winter half-year, and during summer, five persons more, chiefly Welsh women. Estimated produce 100l. per acre.

*Kitchen gardens.* Much fresh littery dung required for growing mushrooms, early cucumbers, salads, potatoes, asparagus, &c. Consumption of the metropolis and its environs, for fruits and vegetables, estimated at upwards of a million sterling per annum. Several farming gardens pay 1000l. per annum.

*Nursery grounds.* About 1500 acres, producing 75,000l. a year.

### 10. Woods and Plantations.

*Copses and woods* decreasing for ages; still a few acres near Hampstead and Highgate.

*Hedgerow timber* much disfigured by being pollarded or pruned to may-poles.

*Willows or osiers.* Many islets on the Thames, rented by basket makers, and planted with osiers; also wet borders of the river so planted. Species *salix vitellina*, *amygdalina*, or almond-leaved, and *viminalis*, or osier; willows when cut, made up in bundles, or boulds, forty-two inches round, at sixteen inches above the but-ends.

### 11. Improvements.

*Drainage,* to carry off surface water. The mode of making surface water flow on meadows by means of an addition to cart wheels, (3979.) invented by the reporter.

*Milk* produced in London by 30,000 horses, 8000 cows, and 700,000 Christians, equals 500,000 loads; of which, half is carried into the Thames by the sewers, including ninety-nine per cent. of the night soil.

### 12. Live Stock.

Less live stock on the farms of this county than in any other: no breeding. Short horned cows of Holderness chiefly used by milkmen: number kept 8500; average produce nine quarts per day; fed on hay, turnips, brewer's grains, linseed cake and jelly, and grass: retail dealers adulterate the milk, preferring dirty water to clean; and adulterate the cream by adding molasses and a little salt. Very little butter made in the county: the sewer's drays supplied with horses from the Berkshire farmers, who buy them young from Northamptonshire, and work them two or three years before they sell them. Not more than one dove house in the county; but many pigeons kept in empty wine pipes set upon posts, fifteen or twenty feet high, and many kept by journeymen tradesmen, pigeon fanciers in the poorer parts of London, and most of other towns and villages of the county.

### 13. Rural Economy.

Half the manual labor done by the job; laborers ruined in morals and constitution, by the public houses. Gentlemen's servants a bad and contaminating set.

### 14. Political Economy.

Highways of the parishes good, turnpike roads bad, beginning now (1825) to be improved; several canals terminate in or near London, and New River for supplying water; falls on the decline. Unproductive the greatest corn market at Mark Lane. Great cattle markets, Hounslow and Smithfield. Commerce great. Manufactures not many; considering agriculture as a manufacture, and the soil as the raw material, and worth 16s. per acre, at an average of England; it is increased in value to 5l. or 55s. per cent. Distilleries and breweries numerous.

### 15. Obstacles to Improvement.

Tithes, land-agents being attorneys, bad leases, bad rural artificers, bad and thieving servants.

### 16. Miscellaneous Observations.

Society of Arts, Veterinary College, excellent institutions. Fines called heriots should be removed; weights and measures regulated; much damage is done by game.

### 17. Means of Improvement.

Ample in the metropolis; want of intelligence, the grand drawback.

6093. SURREY. A surface of 519,040 acres beautifully varied: poor and heathy in the west, chalky in the east, and clayey in the south. The field cultivation of clover and turnips appears to have first taken place in this county. (*Stevenson's Survey, 1813. Malcolm's Survey, 1809. Marshal's Review, 1818. Smith's Geological Map, 1821.*)

### 1. Geographical State and Circumstances.

*Climate.* Healthy winds S. W. and W. : a seldom blows from any point between N. W. and N. E. for any time. East winds

in spring, and then weather cold, raw, and drizzling. Most rain falls when the wind is S. S. W. or S.

*Soils.* Various and most irregularly distributed; a broad zone of tenacious clay bordering Sussex; patches of brick

earth at Walworth, Sutton, and Stoke. Considerable extent of chalk hills from Cropton to Nutfield, and thence narrowing to the western extremity of the county. A good deal of black rich land interspersed among all the soils.

**Surface.** St. Anne's Hill, Cooper's Hill, and Richmond Hill celebrated; Leith Hill the highest, commands a prospect of from thirty to forty miles on every side.

**Minerals.** Iron ore, fuller's earth, firestone, limestone and chalk. Iron-works on the downs, on account of the dearth of fuel. Abundance of fuller's earth in the southern part of the county, which has been dug since the beginning of the eighteenth century. Excellent firestone: when first quarried soft; kept under cover a few months becomes compact, and is able to endure the action of a common fire. Owing to this stone, Dawson, the discoverer of the Vauxhall plate glass works, can make plates of such a size as to surprise the French, from whom he discovered the art of plate glass making in the disguise of a common laborer. Excellent limestone at Dorking, which hardens under water; contains a little flint. Chalk used chiefly as a manure. The soil about Ryegate, the finest in the kingdom; and, in considerable demand for egg and hour glasses, writing-sand boxes, &c. At No such, there is a bed of brick earth, from which fire bricks and crucibles are made.

**Water.** Scarce in many places, particularly on the chalk. Several supplies procured round London, by boring down from one hundred to three hundred feet to the chalk stratum, where the water is excellent, soft, and abundant.

**Fish ponds** common on the heaths, at the western side of the county, have been used for upwards of two centuries, for breeding and rearing carp and other fish. One of the largest, containing one hundred and fifty acres, is near Hersham.

**Mineral waters** numerous. Epsom water is impregnated with sulphate of magnesia, and is purgative. Epsom salts originally made there, now chiefly from common salt water at Lymington in Warwickshire. The other springs are more or less impregnated with sulphate of magnesia, carbonate of lime, and iron.

#### 2. State of Property.

No large estates: largest 10,000, a year. Yeomanry not numerous; but some gentlemen receive 4,000 l. per annum from their own estates, of from 3000, to 4000 l. per annum. Estates mostly managed by attorneys; so far proper as to law terms, but as absurd as to agricultural restrictions, as it would be to employ a farmer to draw up the covenants in technical language. Till the farmer becomes active, inquisitive, free from prejudice, and intelligent, no covenants, or care of attorneys and lawyers will prevent him from trying himself and his landlord by bad husbandry. When he becomes active, &c. he will take care of the landlord's interest for the sake of his own, and the first step to forcing the farmer to become active and intelligent is to leave him to the exertions of his own mind. Tenures chiefly freehold.

#### 3. Buildings.

Few counties that can vie with Surrey in the number and elegance of its country seats. (*Excuse of Garden, Surrey*.) Possesses a great advantage over the north and east of Middlesex and Essex, in this respect, as the prevalence of the S.W. winds drives away the smoke of London. Proprietors generally reside on their estates, and eagerly introduce improvements.

**Farm-houses and offices.** Ruinous and mean in the weald, or clayey district bordering on Sussex; better in other places. Oldest brick covered with slate, stone, or brick joggling and tiles; situations seldom central or convenient to the farm, in villages. Stables not divided into stalls. Cow-houses near London, good. Cottages often large, convenient, and picturesque; with a porch, a flower plant and vine in front.

**Drinking ponds.** Great attention paid to these on the Surrey hills; generally a first pond, where the water deposits its grosser dirt and mud before it enters the second.

#### 4. Occupation.

Farms of all sizes, but mostly small, forty and fifty acres to three hundred. Largest farm between Guildford and Farnham is Wantborough; it contains 1,600 acres; formerly occupied by Montagu Birkbeck, and now by his son. Average size one hundred and seventy acres. Tendency to large farms, by which the public is unquestionably benefited, certainly by the saving of labor, and, in all probability, by the superior cultivation and increased produce. The driven out farmer may generally support or enrich himself equally well though in a different line of life. "But in every country, in all situations and circumstances, and in our own country, particularly in the situation in which it is now placed, it is of the highest importance to consider, whether a mere increase of wealth may not be purchased too dearly: whether it is prudent or wise to diminish the number of those whose souls are knit to their native land, by stronger ties than are known to the mere manufacturer; or the peasant; it can be little satisfaction to see his country the richest in the world, if the measures and causes which make it rich, diminish, in the most trifling degree, its independence; either by raising any passion above the love of our country, or by diminishing the number of those who must be its most natural and powerful defenders. To the merchant it can afford little pleasure to be told, that by the saving of agricultural labor, the manufacturers of his country will be extended or increased, if he perceives that by the change of employment the health and virtue of part of the community are sacrificed." (Stevenson.)

**Farmers.** Old class about the clayey wealds, equal enemies to improvement in agriculture, and relaxation in morals; and have no idea of educating their sons, and so little of the spirit of commerce, that they prefer selling their grain to an old customer at a lower price than taking a higher from a new one. Go to market in round frocks, the dress of their forefathers, and shy and jealous to strangers. Nearer town the farmers are more on a par with the age; but, either unable or unwilling to communicate information, some exceptions of liberal, enlightened, and communicative men. Many tradesmen have turned farmers, and occupy lands near town.

**Rent** low. Tithe rigidly exacted, poor's rates, and other outgoings high.

**Leases** general, for fourteen or twenty-one years, or on three lives.

#### 5. Implements.

Great variety of ploughs, swing ploughs, the Scotch swing

plough used only in two places; bad effect of so many different sorts of ploughs on the servants. The cultivator used by Birkbeck, and highly approved of:—with six horses, goes over eight acres in a day. Lester's friction threshing machine introduced in a few places, and found to succeed: but it threshes very slowly, and has no advantages over Melville's; but that of not breaking the straw, and of which several tags is to be trifling over to render it general. Very few winnowing machines. Sowing troughs in use, the advantage of which, is, that the sower fills it himself instead of having a woman, toiling through rough ground. Sinter machines also in use, in one or two instances. (2618.)

#### 6. Arable Land.

Proportion considerable, tillage bad. Drilling, though introduced by Duket, of Esher, and strongly recommended, is confined to a few adjoining parishes, where the soil is light. Fallowing on clay general, but most imperfectly executed. Rotations generally good.

**Turnips**, supposed to have been grown in Surrey as long or longer than in any county in England. Sir R. Weston, of Sutton, having described the Flanders culture in 1645, and as he addressed his book to his sons, it is thought they were the first to give instruction in the culture of them, and seldom in raised drills. The Siberian turnip has been tried; it is a variety between the cabbage and turnip, but with a root inferior in point of size and flavor to the latter, and a branched loose top; it does not seem adapted for field culture, though as a novelty it deserves trial and attention. Carrots were well on the sandy soils. Potatoe tops sometimes given to cows, cut when in flower; a bad plan with a view to the tubers. Clover introduced by Sir R. Weston at the same time as turnips. Saintfoin succeeds well on calcareous soils, producing good crops for eight years. In forming a new road through a field of saintfoin, between Cropton and Godstone, the roots were found to have penetrated several feet beneath the surface. The culture of hops, brought from Suffolk to Farnham about A.D. 1600; prefer a calcareous sub-soil: occupy 800,900 acres. Farnham hops esteemed more than others, because picked earlier, and hence more delicate, and better sorted. Peppermint, lavender, wormwood, camomile, liquorice, and poppy, grown near Mitcham, and more than twenty other seeds also grown extensively at Battersea. Onions for seed at Mortlake and Barnes; though chiefly at Deptford. Three thousand five hundred acres of Surrey employed in raising vegetables for the London market. Orchards attached to many of the farms, sufficient to supply from four to twelve hogheads of cider. Generally in the Covent garden market, where they are called *Richmond* walnuts grown to cultivation in Pine trees in moss; in the reign of Charles I. brought box trees from Kent, and planted there. Many with good reason think it not planted, but aboriginal. Soil of the hill pale loam or chalk; timber now all cut; brought only five pounds per ton. Many fir trees on chalk hill; at Crowhurst, one fifty feet high and thirty-six in circumference. Brooms made from the ware and spray of birch to a great extent. Fine limes at Beckenham. One hole of the grounds about Chertsey and Byfleet, brought the same rent one hundred and fifty years ago which they do now. Furze grown for the burning of bricks; sown both broadcast, and in drills; cut every three years, and bound like corn, then stacked.

#### 7. Grass Land.

But in small proportion to the rest; most pasture in the wealds. Paring and burning considered by Birkbeck as the best first step of breaking up old grass lands.

#### 8. Gardens and Orchards.

Asparagus grown in great quantities at Mortlake, East Sheen, and Battersea. Malabar and other seeds also grown extensively at Battersea. Onions for seed at Mortlake and Barnes; though chiefly at Deptford. Three thousand five hundred acres of Surrey employed in raising vegetables for the London market. Orchards attached to many of the farms, sufficient to supply from four to twelve hogheads of cider. Generally in the Covent garden market, where they are called *Richmond* walnuts grown to cultivation in Pine trees in moss; in the reign of Charles I. brought box trees from Kent, and planted there. Many with good reason think it not planted, but aboriginal. Soil of the hill pale loam or chalk; timber now all cut; brought only five pounds per ton. Many fir trees on chalk hill; at Crowhurst, one fifty feet high and thirty-six in circumference. Brooms made from the ware and spray of birch to a great extent. Fine limes at Beckenham. One hole of the grounds about Chertsey and Byfleet, brought the same rent one hundred and fifty years ago which they do now. Furze grown for the burning of bricks; sown both broadcast, and in drills; cut every three years, and bound like corn, then stacked.

#### 9. Woods and Plantations.

The wold formerly a wood: some copse there still: hoops grown; charcoal for gunpowder made from hazel, dogwood, &c. common charcoal, hop-poles and faggots. Box Hill, formerly called Whitehill, by tradition originally cultivated, till the Earl of Arundel, in the reign of Charles I. brought box trees from Kent, and planted there. Many with good reason think it not planted, but aboriginal. Soil of the hill pale loam or chalk; timber now all cut; brought only five pounds per ton. Many fir trees on chalk hill; at Crowhurst, one fifty feet high and thirty-six in circumference. Brooms made from the ware and spray of birch to a great extent. Fine limes at Beckenham. One hole of the grounds about Chertsey and Byfleet, brought the same rent one hundred and fifty years ago which they do now. Furze grown for the burning of bricks; sown both broadcast, and in drills; cut every three years, and bound like corn, then stacked.

#### 10. Heaths, Commons, and Common Fields.

Extensive heaths on south-west; surface flat, soil black sand, and gravel. A number of commons, and great extent of common field lands.

#### 11. Improvements.

Draining, paring, and burning. Manuring with London manure of a great variety of kinds.

#### 12. Live Stock.

Very inconsiderable; only six hundred and nineteen cows kept for supplying London with milk.

Duket of Esher used to rear calves to a great extent; many cattle fed by the distillers and starch manufacturers. Adam of Mount God, one of the architects of that name, having constructed extensive buildings for cattle, and stall-feeds six hundred at a time. Sheep kept in considerable numbers on the chalk hills and wealds. Birkbeck has been very successful in cross-breeding with merinos, that is, with the Ryeland merino of Dr. Parry, and the South Down. Immense number of pigs, and one of the districts, as of geese kept on the wealds. Dorking hens are well known. (6685.) A hare warren near Banstead Downs, already described (6613.)

#### 13. Rural Economy.

Hands scarce; servants unsettled; prejudiced, like many of their masters, against all new practices.

#### 14. Political Economy.

Bad roads, though flints and other good materials abound in many places. An iron railway between Wandsworth and Westham for general use, the first in the kingdom of that kind, the rest being confined to the carriage of goods belonging to individuals; this open to all who choose to employ the waggon; as a canal is open to all who choose to employ the boats. Though on a level, and admitting of carriage both ways, yet not found to pay. The first canal locks in England were erected on the Wey. Sir R. Weston, of Sutton, brought the



confrance from Holland, and under his direction, the Wey was rendered navigable from Guildford to Weybridge, about 1690. Numerous fairs, several flour, paper, and oil mills. An extensive iron work at Garrattine near Wandie; a mill for

6994. SUSSEX. A maritime county of upwards of 900,000 acres; distinguished by chalk hills and extensive wealds, a rich soil, but little excellence or variety of agriculture; excels in South Down sheep. (*A. Young's Sussex*, 1809. *Marshal's Review*, 1818. *Smith's Geological Map*, 1819.)

### 1. Geographical State and Circumstances.

*Climate.* Warm in western part, bleak on South Down hills; westerly gales violent, nroof stacks, hedges injured by the spray of the sea.

*Soil.* Chalk nearly the universal soil of the South Down hills; clay of the wealds, which constitutes more than half the surface of the county. Rich land about Chichester, and sand and gravel in a few places.

*Surface* hilly, most so where the soil is chalk. No high hills.

*Minerals.* Sussex or Petworth marble used by the statuaries, but not generally. Limestone, ironstone, sandstone, chalk, marl, and fuller's earth.

### 2. State of Property.

Largest estate 7500l. a year. Most proprietors hold land in their own occupation, and pay great attention to its culture, as E. of Egremont, D. of Richmond, E. of Chichester, Lord Sheffield.

### 3. Buildings.

Noblemen's seats splendid, of stone; farm-buildings generally of stone; on the South Downs built of flints; houses very generally faced with tiles, which keeps the walls dry. Corn generally stacked on circular stone piers, which prevents vermin. Sheep-yards or permanent folds walled round, and furnished with sheds and hay-racks, have been built by Ellman and some other eminent sheep farmers on the Downs. Large wooden barns. Cottages of stone, and on the Downs of flints, and more comfortable than in many parts of England. Magnificent semicircular piggery, erected by E. of Egremont at Petworth.

### 4. Mode of Occupation.

The most extensive farms on dry soils. Average of the wealds 100 acres. Size on the Downs 1200 to 2000 acres. Tithes taken in kind in many places, in others compounded for. Poor rates high.

### 5. Implements.

Plough with two wheels, large and singularly clumsy. The Rotherham plough introduced, and deemed a real improvement. Several excellent new implements introduced by the noblemen already mentioned.

### 6. Enclosing.

County enclosed from earliest antiquity; fields small; hedges very irregular and broad. White thorn fences at Goodwood; by the Duke of Richmond, trained in a masterly manner; being like walls, or rather hogged mazes, of verdure rising from the earth.

### 7. Arable Land.

Tillage bad, three or four horses to a plough with a holder and driver; plough from one half to three quarters of an acre a day; following general on the stiff soils. Rotation bad, barley often follows wheat. Wheat trod in on the sandy lands; threshed by flail, and generally cleaned with a shovel and broom; one or two threshing and winnowing machines. Oats a great deal cultivated on the wealds. Pease much cultivated on the South Downs. Hops much cultivated on the eastern part of the county; but not found profitable. Rhubarb, and the poppy for opium cultivated by E. of Egremont. The roots of the rhubarb, after growing seven or eight years, are taken up, washed, dried in the sun, and then cut in slices and dried on the hot-house flues. (5518.) Incisions are made in the poppy heads, and the exuded juice, when dry, scraped off into an earthen vessel, dried in the sun, and preserved for use. Incisions are made as long as milk flows. André, the domestic surgeon, uses the home-grown rhubarb and opium, and no other. Saiter does all on the chalk, and has a mill near Eastbourne and Brighton. Lord Egremont tried 100 acres of chibroy, and found it support much stock, though on a poor soil.

### 8. Grass Land.

Badly managed; overrun with rubbish. One person tried hay oiled when stacking; he oiled every layer, with a watering pan and rose, lightly with linseed oil; the hay came out moist and clammy; and poultry, beasts, and sheep were fond of it, but it was deemed too hot for horses. Salt sprinkled on hay when a little damaged found a great advantage; it is done in stacking.

### 9. Orchards.

Some considerable orchards, and cider made. One or two

6995. KENT (*Cant or Angle*) forms the south-east corner of the kingdom, and extends over 935,600 acres. It is diversified by chalky eminences in some places, low marshy grounds on the Thames and part bordering on Sussex, called the Weald, or wood (Saxon). It is one of the oldest cultivated counties in England; it was noted even by Julius Cesar, as "the civilest place of all this isle, and full of riches." Viewed from the great road from Dover to London, a more garden like appearance than any county in Britain. Its agriculture is various, and it is celebrated for the culture of hops, fruits, barley, and various garden crops. (*Boys' Kent*, 1796. *Marshal's Review*, 1818. *Smith's Geological Map*, 1819.)

### 1. Geographical State and Circumstances.

*Climate.* Subject to cold winds; the prevailing are the N.E. and S.W.; former in winter attended by severe frosts, twelve inches of ice, and the destruction of turnips. Milder in S.W. part of the county. In Sheppy and Thanet an early harvest, commences July 30, on the hills 1st August.

*Soil.* That of Thanet rich on rock chalk; of East Kent very various; chalk, loam, strong loam, hazel mould, stiff clay, flint, gravel, sand. Isle of Sheppy strong stiff clay; West Kent very various, but chalk and loam on chalk rock prevails; Weald chiefly clay, but mould, sand, and gravel in a few places. Romney Marsh sediment of the sea; a soft loam and clay.

*Surface.* Gently varied hills of chalk; Downs not so high as those of Sussex.

staves at Stoke; a delit manufactory at Mortlake. A horizontal cut, mill of a new construction at Battersea bridge; several distilleries, brewers, and starch manufacturers. Poor, numerous and degraded. Poor's rates enormous.

fig orchards at Tarring, near Worthing. (See *Encyc. of Gard. Sussex*.)

### 10. Woods and Plantations, 175,000 acres.

County celebrated from the remotest antiquity for the growth of its timber, especially oak. County at the conquest one continued forest, which extended from Hampshire to Kent. Underwoods cut at twelve years, for hoops and hop-poles. Ash the most profitable underwood. Finest oak-timber at Petworth.

### 11. Wastes.

Of considerable extent to the north of the county. Some hundreds of acres improved by E. of Egremont answer well.

### 12. Improvements.

E. of Egremont sent for Elkington to find water to fill a lake. E. undertook to do so, but all his trials and predictions of the effect of certain borings and open cuts which he caused to be made proved abortive and useless, and water was found. Failed in three remarkable instances at Petworth, which drained a meadow very well. Lord Egremont considers him as not a scientific drainer, but a very good common drainer, and nothing more.

### 13. Live Stock.

Cattle and sheep among the best in the kingdom; cattle red-little dairying; generally breeding and feeding. Oxen worked extensively by E. Egremont and Lord Sheffield; broken to the yoke at two years and a half; yokes five feet long used and preferred by Lord Egremont. Lord Sheffield harnesses the same as for horses; twelve oxen and nine horses required to work 200 acres in tillage. For hoven cattle one quart of linseed oil given, which vomits them directly, and next fails in giving relief. South Down sheep celebrated. Ellman the first breeder both of cows and sheep; breeds from the same race. New Leicester and Spanish breeds introduced to the county by Lord Sheffield. Rabbits abound and flourish every where, and are the nuisance of the county. Fowls fattened to great perfection at North Chappel and Kinsford; food, oats ground, hog's grease, sugar, not liquor, and milk, all mixed; or cast, treacle, and suet; also sheep plucks; they are kept very warm, and crammed morning and night; put into the coop two or three days before they begin to cram them, which is done for a fortnight, when they weigh 7 or 8 lbs. each, and are sold to the biggiers: average weight 5 lbs., but some weigh double. One of Lord Egremont's tenants crams 200 fowls a year; many capons fed in this manner; great art requisite in castrating them, and numbers die in the operation. The Dorking or Darking fowls extensively raised in the wealds of Sussex; Horsham principal market for them.

The fish-ponds on the weald are innumerable; carp the chief stock; but tench, perch, eels, and pike are raised. A stream should always flow through the pond, and a marly soil is best; carp fed with pease in marl-pits have weighed 25 lb. per brace. Carp kept five years before selling; then twelve to fifteen inches long; 100 stores, or one year old carp will stock an acre. At one year old, carp is three inches long; at two years old, seven; at three, eleven or twelve inches; at four, fourteen or fifteen; and then they breed. Lord Egremont has breeding and feeding ponds; fishes them every three years.

### 14. Rural Economy.

Labor high, as smuggling attracts away many young men.

### 15. Political Economy.

Roads bad on the clayey districts, good on the chalk. Rother river rendered navigable at Lord Egremont's expense. Fairs numerous. Manufactures of iron, charcoal, gunpowder, paper, bricks, and potash. Large court of poor-houses at Eastbourne, of which a plan and electric plan given in the Report. In 1772 a society was established at Lewes for the encouragement of agriculture, manufacture, and industry, by John Baker Holroyd, Esq. now Lord Sheffield, and premiums offered; but on the breaking out of the war in 1778, it was dropped. In 1797 Lord Egremont established a society at Lewes, and gave large premiums. This society still exists. The patriotic and charitable exertions of E. Egremont are most extensive. He gives away to poor objects immense quantities of clothes; food twice a week; feasts all the laboring classes at Christmas, and keeps a surgeon, apothecary's shop, and midwife, entirely for their service; they are also inoculated, and instructed gratis, &c.

*Minerals.* Numerous chalybeate springs, at Tunbridge Wells the chief.

### 2. State of Property

Much divided; number of yeomanry on the increase; 9000 freeholds, and a good deal of church and college lands; socage and gavelkind tenures prevalent.

### 3. Buildings.

Twenty or thirty noblemen's seats, and many seats of gentlemen and citizens, merchants; bankers, &c.; few modern-built farm-houses; old ones of oak or chestnut, and ill contrived; thatched; now improving considerably. Cottages are in general comfortable, built with bricks and tiles.

### 4. Mode of Occupation.

Size of farms greatest on poor lands; many farms from ten

to fourteen acres each, few exceed 200 acres, some 600 to 1500 acres. Tithes in many parts collected in kind. Leases for fourteen years most common. Many church leases on three lives, some on twenty-one years, renewable.

5. Implements.

Kentish turnroot plough almost the only one known in the county, drawn by four horses in heavy, and three in light soils. Corn rakes in use after mown corn. Stubble rakes to drag stubble together; first thrashing machine erected at Betsanher by the reporter.

6. Enclosing.

No common field lands but several commons; fences old and broad, bells of copse more frequent than thorn hedges. Water fences eight to fourteen feet wide, and from three to five feet deep in the marsh lands; post and rail fences prevalent in Romney Marsh. Neither fences, drains, or water furrows wanted in Thanet, where corn is grown, and often for years in succession without mature.

7. Arable Lands.

Plough for all crops from five to seven inches deep. Fallows always made on poor lands. Rotations good. Pease of various kinds for podding are sown from the middle of February to the end of March. Leadman's dwarf and the early grey thought the most prolific. Canary seed and radish seed much cultivated in Thanet and East Kent for the London seedsmen. Radish seed sown in March, and crop seldom fit to reap before October, and is sometimes out on the fields at Christmas without receiving any injury from wet weather; requires much rain to rot the pods that it may thresh; will produce from eight to twenty-four bushels per acre. Spinach sown in March in Thanet; when in blossom the male plants (it being a dioecious plant) are pulled and given to pigs with advantage. Crop threshed on the field; produce, two to five quarters per acre. Kidney beans much cultivated at Sandwich and in Thanet for the London seedsmen; plant from five to ten gallons per acre between the 8th and 20th of May; if earlier in danger of frosts; pulled up by roots from August to October, tied up in bunches and hung on poles to ripen; produce, ten to twenty bushels per acre. Cress and white mustard sown at the rate of two or three gallons per acre in March; reaped in July and threshed in the field; produce eight to twenty bushels per acre. Weid sown among beans at the last hoeing in the beginning of July; ten or twelve lbs. of seed per acre; pulled when in bloom, which happens the second year, in July, and tied in single handfuls to dry; when dry bound in bundles, weighing thirty lbs. sixty of these a load; produce from one-half to one and a half load per acre. Sometimes remains in stooks or barns for several years for want of a market; at other times 21s. per load; generally bought by speculating merchants, who supply the dyers with it as opportunity offers. Madder formerly much cultivated in the eastern part of the county, now given up; first cultivated on a large scale near Peversham.

8. Grass.

Hay chiefly produced in the marshes and the weald; pastures for dairying on every farm; but no dairy farms of any extent in the county; lands in Kent seldom changed from grass to arable, or the contrary. Hay-making badly conducted in most parts of the county, owing to the scarcity of hands. In Thanet and East Kent lean sheep and cattle brought in and put on the marshes and meadows till fit for the butcher.

9. Gardens and Orchards.

Near all the great towns a considerable portion of land devoted to the cultivation of vegetables; at Deptford and Gravesend are whole fields of asparagus, onions, cauliflowers, &c.; at Maidstone many fields of from one to ten acres of fruit trees; apples, cherries, and filberts raised among hops, the culture of which causes the former to grow with great luxuriance; common practice to plant 800 hop hills, 200 filberts and forty apple and cherry trees per acre; the hops stand twelve, filberts thirty, and the apples and cherries an unknown length of time. Sometimes apples and cherries in alternate rows with two rows of filberts between; filberts also raised among hops without any other trees; trees planted in holes two feet square

and two spits deep; pieces of rock taken out; trees stalked and their stems brushed over with lime and night soil, which is said to make them grow exceedingly. The golden rennet apple and black heart cherries, when a few years planted, bound to a gun and die; yet many old trees in full vigor; cherries do best with land laid down to grass; filberts answer on few soils; best cider-maker Stone of Maidstone, mixes all sorts of apples; golden pippin makes good cider alone; no occasion to watch the fermentation of cider in order to raise it off at any particular time, as alleged in Herefordshire eastward; bound to London by the hoys, and to the north of England by the coal vessels. Fruit orchards considered the most valuable estates. Tithes on fruit 2s. per pound on sales. Cherries require a deep soil, and bear well for thirty years; filberts a stony, shaly sandy loam, rather inferior; they will not bear in rich soil; principal grounds about Canterbury and Maidstone, on deep rich loam with a subsoil of loamy brick earth; produce two to fourteen or fifteen cwt. per acre; average seven cwt.

10. Woods and Plantations.

Principal produce hop-poles, fuel, husbandry wood, and some little for the dock yards; few artificial plantations.

11. Improvements.

Openings made between flat ridges by deepening the furrows; turf and brushwood drains in use; chalk lands when below the reach of frost; sea beach and refuse bricks also used. Several windmills which drive pumps to drain the water from marshlands. Some bogs, drained under the direction of Elkington, and now good meadows. Sea-weed used as manure; several thousand loads are sometimes thrown ashore by one tide and washed away by the next; generally mixed with some yard-dung, which it helps to rot; sand spread on stiff soils without being of any use; powdered kelp sown at the rate of twenty cwt. per acre on pasture, saintfoin, and clover, without any perceptible benefit; weeding, a general practice; country long noted for its clean crops of corn. Thistles in grass lands mown while in bloom never come up again. Some land in Thanet recently embanked from the sea bank thirty-six feet at base, nine feet high, and three wide at top; base of outside angle twenty-two, of inner eleven feet. Borders of the Medway below Rochester offer great scope for embanking and perhaps warping.

12. Live Stock.

Neither a dairying nor grazing county; little attention paid to the breed of cattle. Romney Marsh breed of sheep remarkable for fattening early. Fine teams of heavy horses kept at a great expense. A few rabbit warrens; the rabbits within these few years affected with the rot. Formerly many pigeons, now few; few poultry but for home consumption; few bees.

13. Rural Economy.

Labor generally done by job-servants, scarce, dear, and saucy.

14. Political Economy.

Roads generally good, formed of chalk and flints; or limestone and gravel; roads in the weald very bad for want of materials. As clay is there abundant, if duty taken off bricks they might be burned on the spot and the roads paved; 340,000 will pave a road one mile long and nine feet wide. No canals, but one near Gravesend; fairs and weekly markets very numerous. Agricultural commerce of county consists chiefly in exporting corn to London markets. Manufactures trifling. At Down and Maidstone paper mills; at the Isle of Grain salt-works, in the Weald iron works, and at Whitstable and Deptford copper works. Gunpowder made at Deptford and Peversham, calicoes printed, and linens whitened, at Crayford. Poor well taken care of, earn from forty to sixty pounds per annum by hopping chiefly and other rural employments for their wives and children.

15. Miscellaneous Observations.

Kent Agricultural Society, established at Canterbury in 1795 by Sir E. Knatchbull and P. Honeyman, &c. Some potatoes dried on an oak kiln were found to retain their virtues during long voyages, as attested by letters from the vintualling office.

6996. ESSEX, 1,240,000 acres of marshy grass-lands near the Thames, and the rest arable lands of a mixed culture, chiefly of corn and herbage. It is an old cultivated county; contains many small gardens and seed-farms near the towns, and is one of the few districts in the south-east of England where the plough is drawn by only two horses. (Young's Survey, 1810. Marshal's Review, 1818. Smith's Geological Map, 1820.)

1. Geographical State and Circumstances.

Climate mild; north and east the prevailing winds, which bring blights to plants, and cold and hoarseness to animals; sea general both in the high and low lands.

Soil almost everywhere a loam, and more generally heavy than light. Generally well adapted for grass or corn.

Surface beautiful and fertile; at Deptford and Gravesend are whole fields of asparagus, onions, cauliflowers, &c.; at Maidstone many fields of from one to ten acres of fruit trees; apples, cherries, and filberts raised among hops, the culture of which causes the former to grow with great luxuriance; common practice to plant 800 hop hills, 200 filberts and forty apple and cherry trees per acre; the hops stand twelve, filberts thirty, and the apples and cherries an unknown length of time. Sometimes apples and cherries in alternate rows with two rows of filberts between; filberts also raised among hops without any other trees; trees planted in holes two feet square

2. State of Property.

Estates vary much in size from 5l. to 20,000l. a year; in no county a greater population of small and moderate sized farms occupied by their owners. Managers of large estates sometimes attorneys, capital farmers, or private gentlemen. Farmers of all sorts; land held by farmers on short leases, often at will, sometimes on eight, ten, or twenty-one years' terms. Some of the seed or garden farms neatly laid out (fig. 766.)

766



3. Buildings.

Wanted one of the largest houses in the kingdom; in 1823

pulled down. Andysend well known. Misty Hall a most

767

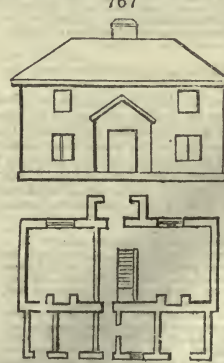

striking place. Gossfield, Thordom, the latter finely wooded by the scientific Lord Petre. Many others; but some districts of the county with very few seats. Farm houses good, out buildings numerous and convenient; expensive rick covers and barns. Cottages not very good; some built on a better plan. (fig. 767.) by the Marquis of Blandford, with a garden of one-fourth of an acre to each. Joseph French at East Horndon, finding labor dear and servants difficult to be got, took the plan of fixing them by building them cottages and attaching gardens.

4. Occupation.

Some of the largest farms in the kingdom; so early as 1767 Arthur Young found some at 1500l. and 200l. a year. Lord Braybrooke farms 1100 acres, Lord Petre 1468. Many farmers men of information, ingenuity, and exertion

These average 4s. 9d. to 6s. per acre when compounded for. Many farms hold on running leases terminable or renewable every seven years. The refusal of leases increasing.

5. Implements.

Essex plough, a large unwieldy implement, with two wheels. A great variety of swing ploughs, all had compared with the Rotherham kind or Northumberland plough. An iron road-leveling plough by Western; a concave roller and scraper attached, delineated in the report, but no reason given for the shape. Many cultivators, scufflers (fig. 768.) &c. delineated, and a donkey hoe. Some of Pasmore's of Doncaster's threshing mills, and winnowing machines, in use. The Scotch cart, plough, or the improved implements introduced by Western. Flemish scythe tried, but found not to answer; did not understand its use. Pattison of Maldon has made an ingenious improvement of the common sowing basket; he has made the bottom a wire sieve for sifting out the seeds of weed in the motion of sowing, and attached a cloth bag beneath for catching them. An anti-hill machine. Good specimens there of amateur improvements on implements.

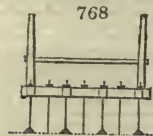

6. Enclosing. Essex for ages an enclosed county; still some waste to enclose. Hedges broad and mixed plants, and with pollard trees.

7. Arable Lands.

Cultivated better than nine in ten of the other counties; plough with two horses or three horses abreast without a driver; fallows universal; rotations good; potatoes cultivated to a great extent for the London market. Carrots in various places planted for seed three feet apart; produce five or six cwt. per acre, sometimes ten or twelve; rye-grass disliked generally; wireworm comes after it, and is sure to destroy wheat. Rape, rye-worm for seed; hops in a few parishes. Saintfoin succeeds well on poor calcareous soils; some lucern. Wire-worm often injurious to young wheat, after clover leys; rolling and treading lessens its effects; on strong soils slugs very troublesome.

8. Grass Lands.

Extensive marshes and salt-lings, (or salt-islets.)

9. Gardens and Orchards.

Some cherry orchards at Burnham; many cottages without gardens.

10. Woods and Plantations.

Fifty thousand acres chiefly natural and ornamental scenery. Some fine old elms at Gosford. At Saint Oath the three original Lombardy poplars which Lord Rochford brought from Italy about 1758, and from which the greater part of those in the kingdom have been raised; they are seventy feet high and seven feet three inches in circumference, five feet from the ground; a Portugal laurel more than fifty-two yards in circumference, and a very large arbutus. The largest abele trees in England at Bellhouse, Avelley; large elms; Lord Petre's sold thirteen oaks for 600 at a load including top and bark. Oaks at Hatfield worth 100 guineas each. Hatfield broad oak celebrated, but now in ruins. An oak at Wimbish increased in girth, four and a half inches in thirteen years; a larch two feet nine inches in the same time; the larch, however, was younger.

11. Wastes.

Forty thousand acres; said that in James the First's time almost the whole county was waste.

12. Improvements.

A good deal of draining; a machine in use like the Flemish mouldebaert (fig. 64.) for lowering the surface of ploughed

6997. HERTFORDSHIRE. A surface of upwards of 400,000 acres, the north part forming a chalky ridge, which extends across the kingdom in this direction; the general features are rich, woody, and the agriculture various, chiefly tillage; the corn produced, well known agricultural author, farmed in this county. (Walker's Report, 1795. Arthur Young's Survey, 1807. Marshal's Review, 1818.)

1. Geographical State and Circumstances.

Climate, dry and healthy. Soil, chiefly loam and clayey loam, next chalk, and a small part bordering on Middlesex gravel; vales, rich sandy loams, chiefly under pasture, and woods very beautiful.

2. Property.

Much divided, the county being a favorite one for wealthy persons building villas and other retreats. 7000l. a year the largest estate; great part copyhold, which sells here at six years' purchase less than freehold.

3. Buildings.

Hatfield, Cashobury, Ashridge (partly also in Bucks), Goshambury, Brocklet, the Hoe, the Grove, Gilstone, Ware Park, &c., noble mansions. Brown's farm yard, at North Mims, one of the best in the county. Immense barns at North Mims and Bedfordbury. Gutters to the eaves of farm buildings at Alkenham; wide fattening stalls, with conveniences for giving hay, water, and oil-cake. Cottages seldom with land attached. A moveable sheep house, at Hillhouse, a cumbersome expensive affair, of which plans, sections, &c. are given in the report.

4. Occupation.

Farms small, largest 500 acres; many of the very small farmers who rent 30l. a year worse off than day laborers. Sir John Sebright, of Beachwood, a scientific breeder, farms 700 acres, 300 of which is in arable and well cultivated. The Earl of Bridgewater, at Ashridge, farms 500 acres, besides the park of 1080 acres. The Marchioness of Salisbury farms 290 acres, besides the park of 1050 acres, and has made many curious experiments; a prejudice against leasars.

5. Implements.

Plough large and unwieldy, with two large wheels, the same as figured in old farming books 150 years ago. One or two threshing machines of Meikle's kind. (Fig. 770.)

lands at those places where they intend making cross-furrows to carry off the water from the regular furrows. The draining-wheel (3978.) in use, inventor not mentioned. Chalk much used as a manure.

13. Live Stock.

Essex never famous for this branch. The largest dairy farms at or near Epping, famous for its butter and cream; no particular sort of cows kept; Derby and Leicestershire breeds preferred, but any taken; fed on natural and artificial grasses in summer, and hay and grains in winter; dairies built on the north sides of the farm houses; milk kept in troughs lined with lead, which hold nine to ten gallons of milk, five to six inches in depth. This in winter is skimmed four, and in summer two or three times, and the cream, after being kept three or four days, churned; milk given to hogs. A few cows kept for milk; in other places for suckling calves, and feeding of the marshes. Western has the finest swine in the county; feeds them in what he calls a hog case; a cage which effectually prevents the animal from taking exercise. A hog half put into a case gains fifteen pounds a week, if well fed with barley meal and water. A miller, near Maldon, has made a treacle case on wheels, to keep moving about on grass land, for its improvement. A portable bridge, carried on a pair of wheels, for passing sheep over marsh ditches, in use by Wakefield, Bourham. (fig. 769.) A decoy for ducks and other aquatic

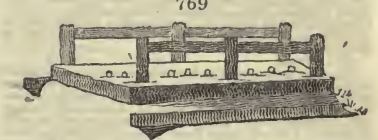

birds in Mersea island, the largest in the county. Every park son that approaches a decoy, takes a piece of lighted turf stuck on a table fork in his hand to prevent the ducks from smelling man. Without this caution they will quit the pond. A decoy at Goldhanger, at which one waggon load and two cart loads of dun birds were taken at one haul of the nets; but the disturbance so frightened such as escaped, that no more were taken that season. Seven fish ponds at Spaines Hill for carp, tench, and eels. A chain of ponds at Leigh's Priory, belonging to Guy's hospital, near a mile in length, and occupying about thirty acres, once completely sluiced and carefully cultivated, now dry and neglected.

14. Rural Economy.

Labor done generally by the piece.

15. Political Economy.

Roads mostly good; few canals; various fairs; and some cattle markets. In the creeks of Crouch, Blackwater, and other rivers and estuaries, considerable quantities of oysters are deposited for breeding. The produce is afterwards dredged and deposited at Wivenhoe and other places for feeding. What are called Colchester oysters are fed there, and sent to Hamburg, Flanders, and France, in time of peace, as well as to London. Oysters are also dredged on the Hampshire coast, and fed in the Coln, or Colchester beds. No distinct account of the oyster economy, however, is given in the report. There are salt-water ponds for various sorts of sea fish in Foulness island; the fish are caught in weirs on the extensive sandy coasts, and deposited, when plentiful, in these ponds, whence they are dragged for with small nets, as wanted.

Manufactures of woollen have existed from time immemorial in the county; also of sacks, hop bags, calicoes, baze, lime, bricks. Much baze made at Colchester, Cogge's Hall, and other places, for Spain. A society of agriculture at Chelmsford.

770

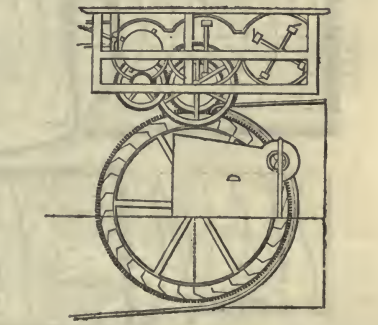

6. Enclosures.

Various, but still some commons and open fields; old fences of mixed species; new ones of thorn; planting well understood, but the cut with the bill made in a direction downwards instead of upwards, as in Berwickshire, by which the stem throws out a brush of small twigs at the wound, instead of a few strong healthy shoots.

### 7. Arable Land.

By far the greater part of the county in tillage: crops chiefly wheat, barley, and oats; turnips and clover supposed to have been introduced in the time of Oliver Cromwell; depth of ploughing generally four or five inches. Greg, who has written a tract on managing clay lands without naked fallows, ploughs as deep as the staple will admit. Rotations various, generally with a naked fallow, once in three, five, or seven years, or oftener. Combing or ribbing in use in some places instead of drilling. Turnips cultivated broad cast, and very poor crops produced; cabbages grown to a large size by the Marchioness of Salisbury, for crows; large red sort preferred. Carrots, parsneps, beets, &c. cultivated by the Marchioness on her experimental farm. Good sainfoin on the chalks. Drilling corn crops with Cooke's drill practised in various places. Water cress for the London market, cultivated in the streams at Rickmansworth. Sixty acres of furze for faggots at Ashridge.

### 8. Grass.

Quantity small, and chiefly a narrow margin near Barnet, on which hay is grown for the London market; some good meadows on the Stort.

### 9. Orchards.

Apples and cherries abound in the S.W. corner of the county on farms of from twenty to fifty acres. In ten years after planting, cherry trees begin to bear; produce till the twentieth year, six dozen pounds; when full grown, fifty dozen pounds; price, ten-pence to three shillings a dozen. Caroon, and small black, the favorite sorts. Kentish will not thrive here. None of the apples for cider: orchards kept in grass, but not mowed.

### 10. Woods.

The copse kind abound in the northern and in many parts of the county; produce faggot wood and hurdles; cut at twelve years; black willow, ash, and hazel, best for hurdles; alders bought by turners and patten makers. Fine woods, natural and artificial, at the Earl of Clarendon's, the Grove, near Watford. A superb oak at Panshanger, E. Cowper's; seventeen feet round at five feet from the ground; called the great oak in 1709: on a soil gravelly above, but, doubtless, clay below. The timber in Moor Park of great antiquity, and in a state of decay; many immense pollards; and, on the whole, one of the most forest-like parks near London. Vast oaks and beeches at Ashridge and Beechwood. Beech excels there; also cedars and the oak, ash, larch, spruce, and common pine excellent. Beech sold to turners, chair-makers, and for barrel staves.

6998. BUCKINGHAMSHIRE. 393,600 acres of hilly surface, and chiefly of clayey or loamy soil; a considerable part chalky, and the agriculture nearly by St. John Priest, *Secretary to the Norfolk Agricultural Society*, 1810. *Malcolm's Survey*, 1794. *Marshall's Review*, 1818. *Smith's Geological Map*, 1820.)

### 1. Geographical State and Circumstances.

*Climate*, cold and windy on the Chiltern Hills.

*Soil*, chiefly clay and chalk, with some gravelly loam; Chilterns wholly chalk; vales generally clay.

*Minerals*. Some ochre, used in painting; a quarry of good marble at Newport, but too deep to be profitably worked; a freestone quarry near Olney.

*Water*. Numerous rivers and canals for sending produce to market; but often filled with weeds, bushes, and other obstructions, which, after heavy rains, occasion frequent floods: a "commission of waters" proposed by the reporter as a remedy.

### 2. Property.

Some large estates, as those of the Dukes of Bedford, Buckingham, &c.: tenures very various: a description of lands here called yard lands (*vivagata terre*), which entitle the holders to certain rights of common.

### 3. Buildings.

Stowe, and Ashridge (the latter partly in Herts), the first of Grecian, the other of Gothic architecture, the two noblest mansions in the county. Tyingham, Wycombe Abbey, &c. also very good houses, and many others; some good farm-houses, and the dairies very clean and neat; churning often performed by horse machinery; the churns of the barrel kind. Lord Carrington has built some good farmhouses, and the Marquis of Buckingham some very complete cow-houses. Drake has a good circular pigeon-house, with brick cells or lockers in rows, with shelves before for the pigeons to light upon; fre-

### 11. Improvements.

Underdraining clay by numerous parallel cuts filled with straw, wood, or stones in general; manuring well understood; much brought from London of every sort; bones, soot, sheep-trotters, night soil, oil-cake dust, rags, leather clippings, furriers' clippings, horn-shavings, malt-dust, hair, sticklebacks, &c. Top dressings more frequent than in any other county. Chalk a very common manure on clayey soils; laid on unburned, and left on the surface to be pulverized by heat and rains and frosts and thaw; then harrowed with a lush harrow, to spread it, and ploughed in. Some irrigated meadows at Rickmansworth and other places; but the frequency of mills is against the process.

### 12. Live Stock.

All the spare clover, hay and straw, carried to London, and manure brought out in return. Sir J. Sebright prefers Suffolk cows and horses, and uses the Wiltshire sheep. A good many house lambs suckled at Rickmansworth, fed with grains and malt-dust in winter. Folding sheep generally approved of. Soiling with clover and tares common. Grey works Suffolk oxen in harness, four to a team. Hon. G. Villiers prefers the Glamorganshire oxen for work; and thinks stall-fed oxen can hardly be kept too warm; prefers oil-cake for finishing to every thing else; Lady Salisbury has the wild breed of pigs, which fatten to forty-eight stone; feeds on lettings, which is found to answer well. Stevenson, the bailiff, bred a gardener, which renders him a superior cultivator of green crops. Lord Clarendon feeds deer (6620.) and sells them. Poultry at the Grove kept in wheeled coops about twelve feet long and two and a half wide, boarded on one side and open on the other; these are wheeled up and down the park, and a boy attends them to keep them as safe as the poultry yard distinct houses for all sorts of fowls; the roosts so contrived that they may not dung on one another.

### 13. Rural Economy.

Ploughmen generally hired by the year.

### 14. Political Economy.

Good roads; few manufactures excepting plaiting straw, which is very general in the county, especially about Dunstable, St. Albans, Redburn, &c. Weak wheat straw from chalky and white land, and such as grows under trees or near hedges preferred. The plaiters give from two-pence to fourpence a pound for it, and sort it themselves. Much malt made about Ware and Hertford for the London market.

quently white-washed, to keep them free from bugs. A foot-bridge at Fawley Court, moveable upon two pivots at its ends, and being heavier on one side than the other, always hangs perpendicularly, excepting when any one walks upon its light side, when the weight of the person keeps it flat; hence it admits the passage of men, but not stock: cottages good, and mostly with gardens attached: some at Brickhill worse than piggeries. Sir J. D. King gives premiums for the best cultivated gardens; also gives clothing and other rewards for good conduct in servitude.

### 4. Occupation.

Size of farms moderate: number in the county 2039; one of 1000 acres, one of 900, four or five between 600 and 700 acres, ten between 500 and 600, twenty-four between 400 and 500, and the rest from 400 down to ten acres; average, 179 acres. Westcar, of Kreslow, a celebrated grazier, occupies 900 acres, of which only between sixty and seventy are arable. Very few leases, and those given with very objectionable covenants. Lord Carrington and other more enlightened proprietors grant leases.

### 5. Implements.

Swing ploughs and four horses in a line common.

### 6. Enclosing.

Has gone on rapidly; old hedges mixed, and with many ash and oak pollards.

### 7. Arable Land.

Ridges high, crooked, with waste spaces between, around, or at the ends. (fig. 771.) Fallow in general every third year,



most common rotation fallow, wheat, beans: chief grains, wheat and barley; beans drilled and hand hoed; some turnips on the light lands.

### 8. Grass.

Pastures a prominent feature; those in the vale of Aylesbury,

especially thence to Bicester, very rich; generally fed, but occasionally mown. Removing at hills called hanking, a piece of management to which the renters of grass lands are generally bound in their leases. They are removed by skinning, gelding, or gutting, and kept down by rolling; thistles are spudded; size of grass fields from twenty to 500 acres.

9. *Gardens and Orchards.*

Few of either worth notice; cherries are grown at Hackwell five feet from the London and Aylesbury market.

10. *Woods and Plantations.*

Willow pollards planted round the margins of fields, on soils suitable for hurdle wood. Birch, the most common timber, very abundant; chiefly used for manufacturing chairs: woods constantly full of young plants from the mast, which grow up and succeed those which are filled; thus the same timber on the same soil and surface for ages. At Sandhoe, a beech seventy years old, the first brought oak and beech trees in Ashridge Park, containing from three to six loads of timber: very fine beeches at Missenden; mast given to pigs.

11. *Improvements.*

Draining much wanted; well performed on some bogs on the Marquis of Buckingham's estates by digging a well and boring in the bottom till the spring was tapped, and then leading it off in an underdrain; paring and burning in general use for irrigating grass land to tillage: chalk much used as a manure, sixty or seventy loads per acre, once in twenty-one years, or forty once in twelve years; allowed to lie on the surface for one winter at least before being ploughed in. Only one instance of irrigation worth notice, which is at Cheneys, by a tenant of the Duke of Bedford.

12. *Live Stock.*

Cattle kept chiefly for beef and butter, seldom for cheese or work; Hereford oxen preferred, and next the Devon; Hedderness cows for the dairy; some prefer the long horned Lancaster, and others the Suffolk; many of the Holderness cows, after being kept a few years, are sold to the London cow-keepers; men are generally the milkers; only one instance found of women performing that operation. Earl of Bridgewater keeps eight teams of Welch, out of Sussex, and one of Durham oxen, all yoked as horses; five used in the cart, and four in a plough; a few other gentlemen have ox teams; cattle generally fed off in summer; cows kept during winter fed on straw, hay, and oil-cake; little herbage or roots in use; milk generally kept in flat vessels of lead; some wooden trays, tinued, in use; skimmed every twelve hours; in some few places three times a day; cream from first two skimmings kept by itself; the third skimming makes what is called after-butter; skimming dish, if tin, circular, a foot in diameter, with holes in it, and a handle upon the top of it; butter made twice a week, in churns of the barrel kind, usually turned by a horse; time allowed for the butter to come, an hour and a half; butter made up in lumps of two pounds each, and sent to London in square flat baskets, eleven inches deep, holding from thirty-six to 120 pounds. They have each on three of their sides three marks, the number of pounds the basket holds; a letter, denoting the farmer's name from whom it is received, and the name and residence of the carrier. The baskets and butter cloths are the property of the carrier; all that the farmer has to do is, to carry his butter to the nearest point where the carrier passes, and to make his agreement with his butter-factor in London, and receive monthly, or otherwise, the payment. Quantity of butter made, six pounds per cow per week, at an average, when in good keep, and not nearly dry. Calves generally sold to sucklers; a few suckled in the county, and a few brought up as stock.

*Sheep.* Culture directed to the fattening of lambs, and the

breeds preferred are the Dorset, and next the Gloucester and Berkshire.

*Horses* generally soiled; five or six put to a plough in many places, and never less than three. A team of asses kept by the Marquis of Buckingham for the use of his garden; many used at the potteries at Amersham.

*Hogs,* an important article on account of the milk from the dairies; breed the Berkshire, and next, the Chinese and Suffolk.

*Ducks,* a material article at Aylesbury and places adjacent; breed white, and of an early nature. They are bred and brought up by poor people, and sent to London by the weekly carriers. One poor man had before his door a small pit of water; about three yards long and one yard broad; at two corners of this pit are places of shelter for the ducks, thatched with straw; at night the ducks are taken into a house. In one room belonging to this man (the only room he had to live in) were on the 14th of January, 1808, ducks of three growths, fattening for the London market; at one corner, about seventeen or eighteen four weeks old; at another corner, a brood a fortnight old; and at a third corner a brood a week old. Ducks six weeks old sold at that time for twelve shillings a couple. Besides the above, there are other persons who breed many more ducks than the person now mentioned, and, as far as it was possible to discover, this person sends 400 ducks in a year to London. Allowing then forty persons to send only as many, at an average of five shillings per duck, the return of ducks from Aylesbury alone will amount to 4000l. per annum. This return has been magnified into 20,000l. per annum.

13. *Political Economy.*

Eye-roads extremely bad and dangerous; difficult to be discovered from mere drift ways; turnpike-roads not to be commended; canals various and useful; grain sent to London at two shillings per quarter. Box clubs generally established for the poor; no agricultural society in Bucks. Principal manufactures paper and lace.

14. *Miscellaneous.*

In calculating the number of acres Priest the Reporter tried the mode, first shown by the Bishop of Llandaff, of weighing the portion of paper containing the map; he next took an exact copy of Cary's map upon paper, by tracing its outline, after the map was strained upon a canvass blind at a window. This copy was cut out with great exactness by a sharp pointed knife, and then divided into pieces, which were so neatly laid together, as to form a right-angled parallelogram: another piece of paper was cut into the form of an assumed parallelogram longer than necessary, upon which the pieces of the copy were laid, and cemented by gum-water, so as to fill all parts of a right-angled parallelogram shorter than that assumed; the difference between the assumed parallelogram and that formed by the pieces of the copy of the map, was accurately measured and subtracted from the assumed parallelogram, and the remainder gave 391,040 acres, the measure of the number of acres in Bucks. Thus then we have the number of acres taken from Cary's map, by weight 396,013, by measure, 391,040. From which, if we take an average, we shall probably state it as accurately as it can be found to be 393,526 statute acres, which, for the sake of round numbers, we will call 393,600 statute acres.

6999. **BEDFORDSHIRE.** An irregular parallelogram of 290,000 acres, not much varied in surface, and for the most part of a clayey soil. The agriculture chiefly directed to the raising of wheat, barley, and beans, but of an inferior description in many respects. Little pasturage; scarcely any market orchards, but good vegetable gardens established at Sandy, on the east of the county, from time immemorial. Great exertions made in every department of culture by the late and present Duke of Bedford, by whom were employed many valuable men in conducting improvements, as Farey, Smith, Salmon, and Pontey. A valuable set of experiments on grasses, conducted by Sinclair under the direction of the present Duke. (*Stone's Bedfordshire*, 1794. *Batchelor's Bedfordshire*, 1808. *Marshall's Review*, 1818. *Smith's Geological Map*, 1820.)

1. *Geographical State and Circumstances.*

*Climate,* mild, genial, and favorable to the growth of vegetables; rather later than Hertfordshire; prevalent winds S.W.; coldest winds N.E.  
*Soil,* chiefly clay, next sand, and lastly in the southern extremely embracing Herts, chalk. Some of the sands gray silts, and producing nothing but heath, others more loamy, as about Sandy, which is supposed to contain the best garden-ground in the county.

*Minerals,* some ironstone; limestone abounding with cornua ammonis, and other shells, petrified wood, pyrites belemnites; freestone, chiefly lime, at Tattenhoe.

*Water.* Principal river the Ouse; several mineral springs.

2. *State of Property.*

Duke of Bedford's estates the largest, next Lord St. John's and Whittred, limited rental estimated at 40,000l. a year. Estate managers attorneys and considerable farmers.

3. *Buildings.*

Several farm-houses were formerly the seats of gentlemen who farmed their own estates. Farm-houses in general badly situated, seldom at the centre of the farms to which they belong, and generally consist of piecemeal erections. Francis, Duke of Bedford, erected an octagonal farm house, on a most commodious plan. (fig. 772.) On the ground floor it con-

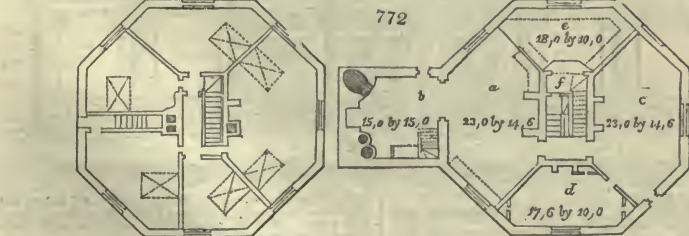

tained a large kitchen (a), bake and brew house, and washhouse (b), a hall or master's room, with a cellar under (c), a good bed room (d), a dairy (e), besides a pantry (f), closets, and beer and ale cellar under. (On the first floor were five, and on

the second (fig. 773.) two good bed-rooms. The expense of this house on the octagonal plan was 6711l. had it been built in the square form it would have cost 7337l. It is built of brick, slated, and was designed by Mr. R. Salmon, a well known

mechanist, resident at Woburn. The same accommodations on a square plan forms a house more convenient for placing furniture. (Fig. 774.) Wattle and dab, that is, clay plastered on hedge work of splinters, or on wood frame work, and also

the *Pisé* manner of clay-working, in use in some places, both for farm-houses and cottages. *Pisé* walls found warmer and cheaper than any other, and when whitewashed said to make good cottage walls.

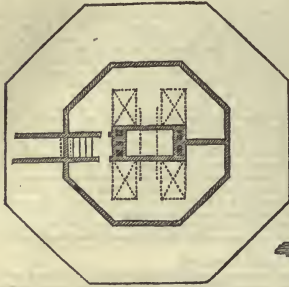

773



4. Occupation.

Many farms of from 200 to 500 acres; average 150 acres; Duke of Bedford's farms generally of the average size. Farmers much improved by the example of Woburn and the annual meetings. The experiments made by Francis Duke of Bedford were to ascertain the quantities of hay consumed by working oxen; comparison between large and small cattle as to food; comparative value of different foods, &c. Tithes mostly in lay hands; farms held generally from year to year, some on leases of fourteen or twenty-one years.

or fallow, barley, beans; turnips common on the sands and chalks, sown broad-cast, and hand-hoed. Chicory was tried by the Duke of Bedford, who found it yield ample produce; had twelve acres which, in 1797, kept six sheep per

5. Implements.

Plough of the swing kind, with a wooden board and a wedge nailed on as a mould board, one fixed handle, and a loose one called a plough staff; the whole singularly rude, though in general use throughout the county. Improved forms of all machines introduced by the Duke of Bedford's Northumbrian manager, and other enlightened men. A good straw cutter and winnowing machine, invented by Salmon; also an excellent weighing machine.

774

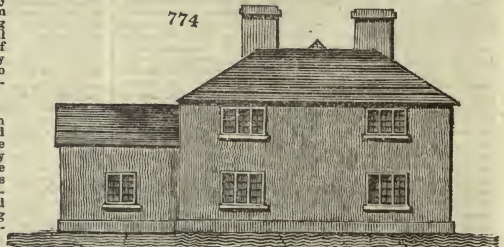

6. Enclosing.

Formerly three-fourths of the county unenclosed, now chiefly enclosed.

7. Arable Land wretchedly ploughed.

Fallows, which occur on the clays generally once in three years, badly worked. Usual crops are fallow, wheat, beans,

acre from the second week in April till Michaelmas; four and a half kept ten sheep an acre from the second week in April till 22d July, and then seven per acre to end of October. Sheep thrive well and free from diseases.

775

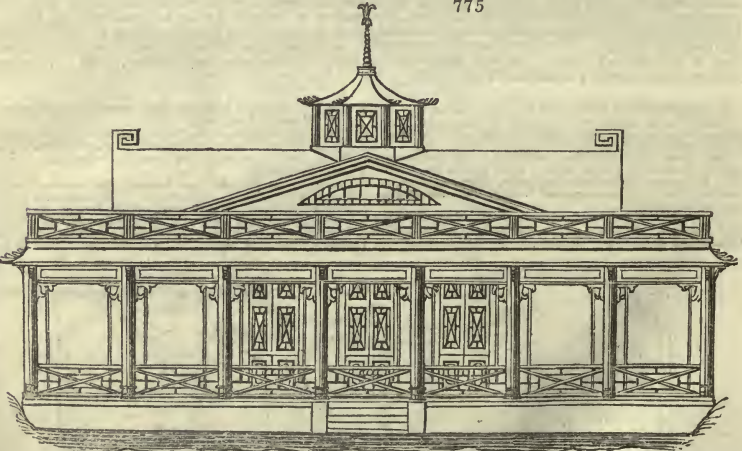

8. Grass Land.

Of very limited extent, and in many places covered with sedge (*carex*), and anthills.

9. Gardens and Orchards.

Gardens of Sandy and Girtford long celebrated for the excellence and abundance of their culinary vegetables. Soil a deep sand, of a yellowish brown color; products peas, beans, cucumbers, potatoes, parsneps, and carrots, radishes, cabbage plants, and turnips; sent to market in all directions to the

distance of sixty miles. Cucumbers chiefly to London, and sold at ten and twenty shillings a bushel for pickling. Orchards small. Potatoes, gooseberries, and other small fruits grown in cottage gardens.

10. Woods and Plantations.

About 7000 acres, situated on the slopes of hills on cold marly clays. Various new plantations formed by the principal proprietors, especially the Duke of Bedford. Furze grown on some of the sandy hills, for burning lime. Some fine trees of

the silver fir, and others of the genus Pinus at Woburn, planted under the direction of the celebrated Miller; a fine beech, figured by Pontey in his *Forest Fruiter*.

11. *Wastes.*

Four thousand acres of chalky down at Dunstable, not much any where else.

12. *Improvements.*

A good deal drained, especially bogs. Elkington's mode said to have been tried with very partial success. Bush and straw-draining attempted on the clayey soils, and the mole plough a good deal used in the furrows. Irrigation introduced by the Duke of Bedford, and various examples are to be found in different parishes on his Grace's estates. Peat is used as fuel, and also burned for the ashes as a manure; ample experiments made on manures, by Dr. Cartwright, at Woburn; but no agricultural experiments on a small scale can be depended on. The dairy at Woburn (fig. 775.) is a fanciful structure in the Chinese style; but the plan and arrangement is not well calculated for keeping milk and butter cool and sweet.

13. *Live Stock.*

Cattle a mixed breed of long and short horned Alderney, &c. Some dairying conducted as in Buckinghamshire. Some sheep, but of no particular breed; folding generally practised and approved of; horses a heavy breed from Huntingdonshire; rabbit warrens destroyed as much as possible; geese kept by many from an idea that they preserve the health of the pasturing animals where they feed. Turkeys and pigeons kept before the enclosure in various places, but now much on the decline. Bees kept by a few cottagers and small farmers.

14. *Rural Economy.*

Husbandry business generally performed by day laborers; though on most large farms horsekeepers, cowkeeper, shepherd and kitchen maid hired by the year.

15. *Political Economy.*

Almost all the cross roads, and many of the main roads very bad. Grand Junction Canal passes through a part of the county, and is very useful; fairs and markets various; manufactures chiefly plaiting of straw and lace; children of ten or twelve years of age acquire the art of plaiting while their mo-

7000. HUNTINGDONSHIRE. A dull flat surface of nearly 200,000 acres; till Edward the First's time one continued forest. The soil is almost uniformly good, but injured by water; it is chiefly under tillage, but remarkable for no excellence in agriculture. Rapeseed and mustard are more cultivated than in most other counties, and timber more rare. (*Stow's Huntingdonshire*, 1793. *Mazwell*, 1793. *Parkinson*, 1811. *Marshal's Review*, 1813. *Smith's Geological Map*, 1821.)

1. *Geographical State and Circumstances.*

*Climate*, tolerably healthy, considering that the east part is skirted by fens, and but a small part supplied by water from springs.

*Soil*. Loam prevalent, but the county every where spotted with roundish patches of clay, sand, marl, fen, moor, or lakes, which, in the map of soils annexed to Parkinson's Report, assumes a very singular appearance.

*Water* chiefly supplied from ponds; Ouse and Nene the only rivers; the meres are natural ponds, surrounded by reeds and other aquatic plants, and a considerable zone of marsh or bog, according as the soil may be loam or sand. Whittlesea Mere contains 1570 acres.

2. *State of Property.*

Old enclosed lands in the hands of a few proprietors; half the county freehold, the remainder almost all copyhold.

3. *Buildings.*

Farm-houses very inconveniently situated, partly owing to the want of high and dry sites on central parts of farms; some good cottages lately erected as the only means of retaining farm servants for any length of time with the same master.

4. *Occupation.*

Many large farms, though small ones predominate; leases frequent; little in kind.

5. *Implement.*

Plough, with one handle, originally from Holland; one wheel, a circular plate of iron which is kept sharp, acts as a coulter.

6. *Tillage.*

Plough with a pair of horses, or three abreast; two crops and a fallow the common rotation; chief crops, wheat, oats, and beans; rape sown on the fens; lands either once ploughed out of grass, or pared and sown also on upland manured and treated as turnips; seed threshed in the field; straw generally burned, or used for yard fences; wheat succeeds well

thers sort and bleach the straw. Lace making, a more sedentary employment, and the women and children generally appear skilful. There are school mistresses for teaching both straw plaiting and lace making. Begin to learn lace at six or seven years of age; do little good for two years, at ten years earn two shillings a week, at sixteen as much as can be made by the business, or nearly six shillings a week; work in summer from six o'clock in the morning till sunset, and in winter from nine till eleven at night; maid servants scarce in consequence, but poor rates kept down. Some rush mats made near the Ouse to the west of Bedford.

*Bedford House of Industry.*—"The poor in the house are employed in the following manner: A manufacture of coarse baize furnishes employment for all the boys five years of age, and some of the men; the remaining part of the men cultivate an acre and a half of garden-ground, and weed and keep in order twenty-five acres of sward land attached to the house. The old women spin flax to make linen for the use of the family; the other women (exclusive of those engaged in domestic concerns), and girls above six years old make thread lace. One-sixth of the earnings of the poor is paid weekly to those who work, by way of gratuity. The Governor of the House of Industry adds, that the above employments have answered the most sanguine expectations of the directors of the establishment."

g. Many useful benefit clubs.

16. *Obstacles to Improvement.*

Want of knowledge and leases. Mice generally destroyed by professional rat catchers; some farmers keep ferrets for the rats. Larks destroy a great deal of new sown wheat. They, with other birds, are very abundant in Bedfordshire, especially about Dunstable, where they are caught in traps, in quantities for the London market. Wire worms supposed to be increased by artificial grasses.

17. *Miscellaneous.*

An agricultural society founded by the Duke of Bedford in 1801; various premiums offered and paid, to the extent of 100*l.*, a year in some years. Cheap publications on agriculture, it is thought, would be a considerable means of improvement.

after rape; hemp sown in a few places; mustard cultivated with great success; sometimes pays 40*l.* an acre on land worth not more than 50*l.* but very uncertain. Parkinson thinks hemp, flax, rape-seed, and mustard, should be encouraged, as they enrich the farmer, and are all good preparatives for wheat. The only way, he says, to enrich the soil, is to enrich the farmer first.

7. *Grass.*

Some good meadows on the Ouse and Nene; the pastures lie remote from the farm buildings, but are in general rich, though neglected; require to be pared and burned, and brought under aration.

8. *Woods and Plantations.*

A good many pollard willows in the fens, and some osier plantations.

9. *Improvements.*

Great want of a general county drainage, such as that of the Bedford level, in the adjoining counties of Lincoln, Cambridge, and Northampton. The advantages of such a drainage is ably pointed out by Parkinson. Embankments very extensive, and the soil being in general a loose porous sand, puddle walls are generally made in the middle of the mound.

10. *Live Stock.*

Stilton cheese, now chiefly made at Little Dalby, in Leicestershire; is no longer made at Stilton, though it is supposed to have been originally made there about 1720; or, according to some, by a Mrs. Orton in 1738. A good many horses bred, and a mixture of Lincoln and Leicester; folding sheep much practised. No fewer than 271 pigeon houses in this county, and a few bees; one gentleman cultivates rabbits.

11. *Political Economy.*

Bad roads; a lace manufactory at Kimbolton; a paper mill at St. Neots; two sacking manufactories at Standground; an agricultural society at Kimbolton.

7001. CAMBRIDGESHIRE. A flat or little varied surface of 450,000 acres, generally of good soil, and mostly under tillage; remarkable only for the extent of its fen lands, and their embankment and drainage, both very imperfect. Horses are a good deal bred in the county, and also pigeons. (*Fancouver's Cambridgeshire*, 1795. *Gooche's Cambridgeshire*, 1807. *Marshal's Review*, 1813.)

1. *Geographical State and Circumstances.*

*Climate*. On the uplands dry and healthy, but in the fens the contrary; there the inhabitants suffer most when the fens are driest. Agues have somewhat diminished since the fens began to be better drained.

*Soils* are very irregularly distributed; loam, clay, and rich black earth extend themselves in irregular masses, and nearly of the same extent. The soil of the fens is rich black, and the marshes in the vicinity of Wisbeach consist of a mixture of sand and clay, or silt; and the uplands consist of chalk, gravel, loam, and tender clay. There are no minerals.

*Rivers.* The Ouse, the Granta or Cam. The Ouse and Nene also cross a part of the county, and the old and new Bedford rivers. All these are navigable for barges, and are kept open in frosty weather by ice-boats, drawn down the stream by eight horses, four on each side.

2. *Estates.*

Very much in size. Those of Lord Hardwicke, Duke of Bedford, Duke of Rutland, Sir H. Peyton, and Thorpe, are

the largest; greatest part of the county in estates of from 200*l.* to 500*l.*, and 1000*l.* per annum; many from 20*l.* to 50*l.* and even 400*l.* a year, occupied by their owners; tenures of all sorts, and a variety of college-land tenures.

3. *Buildings.*

Farm-houses and premises in general bad and inconvenient; lath and plaster, or clay and wattle, the common materials, and clunch or clay walls in general use. Jemyns, of Hottisbarn, has adopted a Mr. Arthur's own plan of building stacks on frames, which run on an iron railway, and are pulled into the barn, where they are forked on to the platform of the threshing machine. Cottages "wretchedly bad," excepting a few built by Lord Hardwicke, and some other gentlemen.

4. *Occupation.*

Farms from twenty to 100 acres; many from 100 to 1000, but few exceed the latter number; tithes taken in kind in many places.

5. *Implement.*

Ploughs, with a sharp iron wheel, or running coulter, as in

Huntingdonshire. Shepherd, of Chippenham, has invented a variety of implements. Some threshing machines, and the best Lothern implements, at Lord Hardwicke's. The *Ely bear roller* is an iron roller, with a number of pieces of iron like small spades fixed into it.

It is used in the fenny districts for cutting up the weeds, which choke up the slow running rivers. The horses walk along the bank, and draw it several times up and down the river. The weeds are thus rooted up, and carried down the stream by the first flood.

#### 6. Arable Land.

Ploughed and cultivated in general as in Huntingdonshire; hemp is cultivated more extensively; flax is grown, and mustard, near Wisbeach and the wells; a few lentils, as in Huntingdonshire, but are considered of less value than tares. The reporter says, a second crop of mustard is obtained by what shells from the first, and that mustard springs up in land where it has not been cultivated for upwards of a century. Wood is in cultivation, and for every forty acres a wood mill, it is said, is required. No crop pays equal to the reed, which requires no culture but cutting and bunching; owing to the improvement of the fens, they are now becoming scarce. Whiteseed (*Poa aquatica*), or fen hay, is produced on many parts of the fen lands, and even on such parts as have been dug for peat. The land is inundated till the crop appears above the water, and then, wherever it can be effected, it is let off; in other cases the grass is cut to a great height in the water, is mown twice in the season, and often produces two tons per acre each time. The hay is esteemed valuable for cows; causing them to produce much milk, and, it is said, giving the particular flavor to Cottenham cheese.

#### 7. Grass Lands.

Extensive; some under no management, and of little value; others very productive, both as hay and feeding lands. In the district called the Wash, they will carry from one to two bullocks, and from five to twelve sheep per acre fed the greater part of the year.

#### 8. Gardens and Orchards.

Good market and fruit gardens at Ely, Soham, Wisbeach, &c. which supply Lynn and various places, by water carriage, with apples, cherries, and vegetables.

#### 9. Woods and Plantations.

Some young plantations. The Rev. G. Jennyns, of Bottingham, "does not cut the top roots of oaks in the usual manner, and finds they thrive faster." (That he is mistaken, see 3646.) Osiers are grown in various places for the basket makers, and found to pay as well as a *cy* crop.

#### 10. Wastes and unimproved Fen.

In 1794, 158,500 acres.

#### 11. Improvements.

In no part of the island draining and embanking so much wanted as in the fens of this county.

The former state of the fen lands, and their degradation to their present state, is given at length in the report, chiefly from a pamphlet by Lord Hardwicke. It was the opinion of Atkins (a commissioner of sewers in the reign of James I. 1604) that these fens (a space of upwards of 280,000 acres) were once "of the nature of land-meadows, fruitful, healthy, and very profitable to the inhabitants, and yielded much relief to the high-land countries in time of great droughts." Sir W. Dugdale (who was born 1605, and died 1686) was of the same opinion, adding as a proof, "that great numbers of timber trees (oaks, firs, &c.) formerly grew there, as is plain from many being found in digging canals and drains, some of them severed from their roots, the roots standing as they grew, in firm earth, below the moor."

On deepening the channel of Wisbeach river, in 1635, the workmen, at eight feet below the then bottom, discovered a second bottom, which was stony, with seven boats lying in it, covered with silt. And at Whitlesae, on digging through the moor at eight feet deep, a perfect soil was found with swards of grass lying on it, which they were first moor. Henry of Huntingdon (who lived in the reign of Stephen, 1135), described this fenny country "as pleasant and agreeable to the eye; watered by many rivers which run through it, diversified by many large and small lakes, and adorned by many woods and islands." And William of Malmesbury (who lived in the first year of Henry II. 1154) has painted the state of the land round Thorney in the most glowing colors; he says, "it is a very paradise, in pleasure and delight it resembles heaven itself; the very marshes abounding in trees, whose length without knots do emulate the stars." "The plain there is as level as the sea, which, with the flourishing of the grass, allureth the eye; in some parts there are apple-trees, in others which are not, they are the authority of the authors quoted, that the fens were formerly wood and pasture. The engineers were of opinion that the country in question, formerly meadow and wood, now fen, became so from partial embankments preventing the waters from the uplands going to the sea by their natural outfalls; want of proper and sufficient drains to convey the waters into the Ouse; neglect of such drains as were made for that purpose; and that these evils increased from the not embanking the river Ouse, and the erection of sluices across it preventing the flux and reflux of the sea; the not widening and deepening, where wanted, the river Ouse; and from not removing the gravels, weeds, &c. which have from time to time accumulated in it.

The first attempt at draining any part of the fens appears to have been made in the time of Edward I. (1272, &c.); many others with various success followed. The famous John of Gaunt (or Ghent, who died in 1359), and Margaret, Countess of Richmond, were amongst the draining adventurers; but Gough, in his edition to Camden, says "the reign of Elizabeth may be properly fixed on as the period when the level began to become immediately a public case. Many plans were proposed and abandoned between that time and 1634, when King Charles I. granted a charter of incorporation to Francis, Earl of Bedford, and thirteen gentlemen adventurers with him, who jointly took to drain the level on condition that they should have granted to them, as a recompense, 95,000 acres (about one-third of the level). In 1649, this charter was confirmed to William, Earl of Bedford, and his associates, by the Convention Parliament; and in 1653 the level being declared completely drained, the 95,000 acres were conveyed to the adventurers, who had expended 400,000*l.*, which is almost 3*l.* 4*s.* per acre on the 95,000 acres, or about 1*l.* 8*s.* on the whole breadth, if the whole level contain 285,000

acres, and it is generally supposed to contain 300,000 acres.

In 1664, the corporation of the Commissioners of the great level of the fens was established. This body was empowered to levy taxes on the 95,000 acres, to defray whatever expenses might arise in their preservation; but only 85,000 acres were vested in the corporation, in trust for the Earl of Bedford and his associates; the remaining 12,000 were allotted, 10,000 to the King, and 2000 to the Earl of Bedford. In an act of 1664 was an annual rate as to its being deemed unjust, a very gradual one was adopted, which is now acted upon. In the year 1697, the Bedford level was divided into three districts, north, middle, and south; having one surveyor for each of the former, and two for the latter. In 1753, the north level was separated by act of parliament from the rest. In addition to the public acts obtained for draining the fens, several private ones have been granted, for draining separate districts within their limits, notwithstanding which, and the vast sums expended, much remains to be done; a great part of the fens is now (1806) in danger of inundation; this calamity has visited them many times, producing effects distressing and extremely beyond conception, indeed many hundreds of thousands of valuable land now drowned, the misfortune aggravated by the proprietors being obliged to continue to pay a heavy tax, notwithstanding the loss of their land.

The interior drainage of the fens is performed in most places by windmills, which are very uncertain in their effects. Steam has been tried, and there can be no doubt would be incomparably more successful as working in all weathers.

Embanking may be considered a necessary accompaniment of draining on the fen-lands. The fens are divided into three large levels, and each of these levels are subdivided into numerous districts by banks; but as these banks are made of fen-moor, and other light materials, whenever the rivers are swelled with waters or any one district is deluged, either by rain, a breach of banks, or by any other cause, the waters speedily pass through these bright, moory, porous banks, and down all the circumjacent districts. The fens have sometimes sustained 20,000*l.* or 30,000*l.* damage by a breach of banks; but these accidents seldom happen in the same district twice in twenty years; the water, however, soaks through all fen banks every year in every district, and when the water mills have lifted the waters up out of the fens into the rivers in a windy day, a great part of the water soaks back through the porous banks in the night upon the same land again. This water that soaks through the bank, drowns the wheat in the winter, washes the manure into the dykes, destroys the best natural and artificial grasses, and prevents the fens from being sown till too late in the season. This stagnant water lying on the surface, causes also fen agues, &c.; thus the waters that have soaked through the porous fen banks have done the fertile fens more real injury, than all the other floods that have ever come upon them. The remedy for the soaking through of the water is obviously that of forming a puddle in the middle, which appears to have been first thought of among the fen bank-makers by Smith of Chatteris, a professed banker, who thus describes his mode of putting a vertical stratum of puddle in old moolds. "I first cut a gutter eighteen inches wide, through the old bank down to the clay (the fen substratum being generally clay), the gutter is made near the centre, but a little on afterwards filled up in a very solid manner with tempered clay, and to make the clay resist the water, a man in boots always treads the clay as the gutter is filled up." This plan was tried last summer (1794), on a convenient farm, and a hundred acres of wheat were sown on the land. The wheat and grass lands on this farm are now very dry, whilst the fens around are covered with water. This practice answers so well on this farm, that all the farmers in the parish are improving their banks in the same manner, and some have begun in adjacent parishes.

With respect to embanking from the sea, Vancouver is of opinion, that the ground ought to be covered with the water, and sown with one or two plants before an attempt is made to embank it; there is particular danger in being too greedy. "If the sea has not raised the salt marsh to its fruitful level, all expectation of benefit is vain, the soil being immature, and not ripened for enclosure; and if again with a view to grasping a great extent of salt marsh, the banks or sea wall be pushed farther outward than the water will bear, the firm and secure foundation for it to stand upon, the bank will blow up, and in both cases great losses and disappointments will ensue."

Paring and burning is every where approved of, and considered the *sine qua non* of the fen district, in breaking up turf. Without it corn crops are destroyed by the grub and wireworm.

Irrigation. Col. Adeeane, of Barham, has 300 acres of fen meadows, which have been irrigated from the time of Queen Elizabeth. "Pallavicino, who was collector of Peter's pence in England, at the death of Queen Mary, having 50,000*l.* or 40,000*l.* in his hands, had the art to turn Protestant on the accession of Queen Elizabeth, and appropriated the money to his own use; he bought up all the waste and bad lands, and other lands near Bournebridge; and procuring a grant from the crown, of the river which passes through them, was enabled legally to build a sluice across it, and throw as much of the water as was necessary into a new canal of irrigation, which he dug to receive it in the method so well known, and commonly practised in Italy long before the time of the canal. The canal is small, and very well designed, and are the work of a man evidently well acquainted with the practice; but in taking the waters from them for spreading it by small channels over the meadows, there does not seem to be the least intelligence or knowledge of the husbandry of watering. No other art is exerted but that merely of opening in the bank of the river small cuts for letting the water into the meadows, which are always irrigated, and never longitudinally, so necessary in works of this kind. The water then finds its own distribution, and so irregularly, that many parts receive too much, and others none at all. From the traces left of small channels in different parts of the meadows, it would appear that the ancient distribution formed under Pallavicino is lost, and that the meadows are now in a state of the miserable patch-work of workmen ignorant of the business. Irrigation has not spread from this example, but might be extensively practised on the banks of all the rivers."

#### 12. Live Stock.

Cattle, a breed peculiar to the county; but some of all sorts. Butchers give more for a Cambridge calf than a Suffolk



folk one, fancying the former white veal. The Cottenham cheese ascribed to the excellence of the grass, in great part Poa aquatica.

The cow system consists chiefly in suckling of calves and making of butter; there is not much cheese made, except the noted ones of Soham and Cottenham. The suckling season is from Michaelmas to Lady-day. It requires, on an average, two cows to fatten a calf. The cows, when at a distance from home, are milked in the pasture, and the milk brought home by a horse or ass, in tubs, slung across: women could not do this work, the travelling being, after the least rain, very bad, even when there is no water to go through. The butter is sold rolled up in pieces of a yard long, and about two inches in circumference; this is done for the convenience of colleges, where it is cut into pieces, called "parts," and so sent to table; its quality is no where excelled.

Bullocks of various kinds fattened on grass, and when not ready in autumn, put up and finished on corn or oil-cake. Col. Adeeane buys in London at a falling market, and keeps till a rising one before he sells.

Sheep chiefly as in Huntingdonshire; some Norfolks and South Downs; folding on the uplands.

Horses of the cart kind much bred, and considered an article in which the county excels; they are very large and bony; black; with long hair from the knee to the fetlock trailing on the ground. A cart stallion has cost 255 guineas, and his colts

7002. SUFFOLK. A crescent-like flat surface of 800,000 acres, the soil chiefly clay, and the agriculture directed to the growing of corn. The county is, however, famous for its breed of cows, horses, and hogs, and it is one of those in which carrots are a good deal grown. The celebrated Arthur Young was a native yeoman of the county, and farmed his own estate near Bury. (*Young's Suffolk*, 1810. *Smith's Geological Map*, 1819.)

1. Geographical State and Circumstances.

*Climate.* One of the driest in the kingdom; the frosts severe; and the N. E. winds in spring, sharp and prevalent.

*Soil.* The predominating a strong loam on a clay-marl bottom in the centre of the county, a zone of sand along the coast, and some sand and fen land in the north-west angle; no minerals.

2. Property.

Chiefly in the hands of rich yeomanry, who cultivate their own estates of from 1000. to 4000. a year; one estate of 80000. a year; and two or three of 60000.

3. Buildings.

Great erections have been made for the convenience of men of large fortunes; but none for those of smaller incomes; farm houses improved, but still inferior to what they might be; often of lath and plaster, and wanting requisite repairs; barns uselessly large; cottages in general bad habitations; the door generally opens from the external air into the living room; repARATION bad, and the deficiency of gardens general.

4. Occupation.

Farms generally large; some from 200. to 1000. a year; generally from 1500. to 9000.; the largest on the sandy districts. Leases for seven, fourteen, and twenty-one years; much land held at will.

5. Implements.

The Suffolk swing plough, well known as one of the best of the old English ploughs; various threshing machines, and other improved implements introduced; circular harrows. (*fig. 776.*)

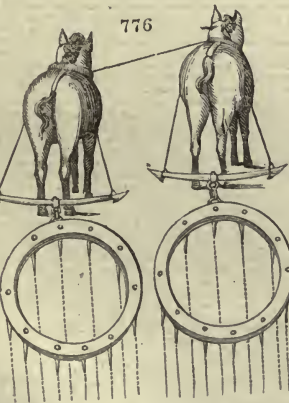

6. Enclosures.

Suffolk one of the earliest enclosed counties in England; a few recent enclosures.

7. Arable Land.

Plough, with two horses, one acre a day on stiff soils, and 1 1/2 to 1 3/4 on sands; ploughmen skillful, and subscribe prizes among themselves for such as draw the straightest furrow, &c. Besides all the common crops, a larger proportion of pease grown than is usual in most counties. Hops, cabbages, carrots, lucern, chicory, and hemp, are grown in a few places. The culture of carrots is, of course, confined to the sandy districts, and that of rape for seed, and of hemp, to the ferry angle of the county. A Young seems to have been the chief cultivator of chicory, having had "ninety acres of it for sheep." Hemp is grown both by cottagers and farmers, and for the seed as well as fibre, but never on a large scale; five acres is the greatest breadth to be met with.

have sold for sixty guineas. Horses kept in the stable throughout the year at a great expense, because on dry food; herbage plants, artificial grasses, and roots being neglected, and no soiling practised.

The deer in Wimpole park attacked by a singular disease, a sort of madness; the diseased animal begins by pursuing the herd, then sequesters himself, breaks his antlers against the trees, and kills a large piece of flesh from his sides, &c. becomes convulsed, and soon expires.

Pigeon-houses on almost every farm; kept in a great measure because if any one were to give them up, he would be obliged to keep the pigeons of others; destroy thatched roofs, and oblige every farmer to sow more seed than he otherwise would; produce sent to London and other parts; often 100 dozen per annum from one pigeonary; dung highly prized.

13. Rural Economy.

Peat, sedge, or thin turf, and dried cow dung used as fuel. The cow dung is spread on grass, about 1 1/2 inch thick, and cut into pieces, eight or twelve inches square; and there it lies till dry.

14. Political Economy.

Roads miserably bad; canals or navigable cuts in the fens in all directions; a few fairs; a pottery at Ely for coarse ware; excellent white bricks made there, and at Chatteris and Cambridge; lime burned at various places.

9. Grass.

Pastures coarse and not extensive; both these and meadows badly managed, overrun with mole and ant hills, bushes, tufts of bad grasses, weeds, &c. Hay-making badly performed.

9. Gardens and Orchards.

Garden walls built of the width of a brick, by making them wavy. (*Encyclopedia of Gardening*, 1567.)

10. Woods and Plantations.

Few, and pay badly; but large oak timber formerly produced in the clay districts.

11. Improvements.

Wheat substituted for rye. Draining much practised on the clays; bushes, straw, or stubble used for filling them; claying and marling the sands practised, but sand laid on clay found of no use, or marl on clay, according to the old adage--

Marle clay, throw all away!

Marle sand, and buy land!

Some workmen procured from Gloucestershire to execute irrigations in the manner of that county.

12. Live Stock.

In cows, horses, and hogs, Suffolk excels. The Suffolk breed of cows spread over the whole county. To keep the breed polled, horned calves are never reared, but sold to the sucklers. Cows in prime give eight gallons of milk per day, and great part of the season six gallons; best milkers red bred, or yellowish cream colored; not always the best feeders. Often fed in winter with cabbages. A point of bad management is, that the bulls, when three years old, or thereabouts, are either sold or castrated for fattening, by which means, when a good stock-getter is thought to be discovered, when searched for he is no more; thus the improvement can be made in the breed, but by accident. Cows are allowed to range over turnip fields and eat where they please, and often the same as to cabbages. In some cases they are tied to posts in the open field, littered, and the vegetables brought to them: both barbarous modes of management. Dairy management not particularly good; women in general the milkers; milk generally seven or eight cows an hour; one for a wager milked thirty in three hours. Quality of milk depends not only on the food, but on the condition of the cows as to health and fatness. Chafing dishes of charcoal kept in the dairies during frost, but the cream does not rise so well. Butter generally salted in firkins.

The sheep used are the Norfolk breed, or as they ought rather to be called the Suffolk breed, with which folding is universally and anxiously practised.

Horses of the best variety found on the sandy soils, as about Lowestoff, Woodbridge, Orford. About the middle of last century a considerable spirit of breeding, and teams drawing against teams for large sums, existed. The old breed were ugly, with slouching ears, ill-shaped head, and low in the fore end; a great carcase, short legs and short back; they could only walk and draw, and no more trot than a cow; of late, by aiming at coach horses, the breed has become handsomer, and one of the best for draught in England. In the east district, horses are turned out of the stable in winter at night, about eight o'clock, into a yard well littered with straw, with plenty of oaten barley straw to eat, but no hay; so treated, they are found to keep free from diseases, and work several years longer than if kept constantly in stables.

The hogs fatten early and at little expense, but are not great breeders.

Rabbits. Many warrens in the sand district; one at Brandon returns 40,000 rabbits in a year; twenty rabbits per acre usual produce; carcase defrays rent and taxes, and the skin profit; so that no mode of farming can be more profitable to the occupier.

Poultry. Turkeys generally cultivated, but chiefly for home use.

Pigeons abound on the borders of Cambridgeshire.

13. Political Economy.

Roads very good; made with flints and gravel; some canals. Ipswich and Bury excellent markets; a good deal of fishing on the coast; spinning and combing wool, and spinning and weaving hem, among the cottagers. Says and silk manufactures at Sudbury. Various hundreds in this county incorporated by charter for erecting houses of industry for the poor; they manufacture netting for the fishers, spin, &c., and cultivate a few acres of land; they are admirably kept and managed, and the poor live like the pensioners in Chelsea college; but these houses of industry have little effect in lowering the poor rates. Mar-

shal considers them as the grave of morality and independent policy.

#### 14. Obstacles to Improvement.

The great abundance of game in the county is such, that Instances are given of corn having been injured to the extent of

**7003. NORFOLK.** A flat surface of 240,000 acres, chiefly of a loamy and sandy soil, and devoted to the growth of corn, and the fattening of cattle and sheep. This county has acquired celebrity for its general culture, and especially for that of turnips and clover. It displays a great variety of practices, and abounds in wealthy farmers. It is also noted for the estate of Coke, a true patriot, the most munificent of landlords, and greatest friend to farmers. Norfolk, in short, was formerly reckoned the finest county in England for agriculture, as Northumberland is at present. Mackie's nursery at Norwich, the property and under the direction of a lady, is one of the most extensive and best managed of provincial nurseries. (*Kent's Norfolk* 1795. *Young's Norfolk*, 1801. *Marshal's Review*, 1813. *Smith's Geological Map*, 1819.)

#### 1. Geographical State and Circumstances.

*Climate* colder and more backward than Suffolk; N. E. winds severely felt in spring; salubrity of the air affected by the fens of Lincolnshire and Cambridgeshire to the extent of 5 or 600,000 acres, which lie on the west side of the county.

*Soil.* A sandy loam or sand; Kent says, similar and equal in value to that of the Austrian Netherlands. There is a small patch of silt or warp clay on the borders of Lincolnshire, and of rather stiffer clay on the borders of Cambridgeshire.

*Water.* The sea affords rivers for navigation; watering ponds for cattle made; Holkham, each to serve four enclosures, forty-two feet square at bottom, twelve and seven feet deep, bottom and sides well covered with sand; within a yard of the top, the clay two feet thick, and paved with bricks set on edge. These ponds made by men from Gloucestershire at two and sixpence per superficial yard. To divide the ponds for four fields, a large stone was brought in it to receive a post, is necessary at the centre, and the post has mortices to receive rails from the sides.

#### 2. Property.

Estates of all sizes; one of 25,000l. a year, one of 14,000l., one of 13,000l., two of 10,000l., many of 5000l. Land sells currently at thirty years purchase. Tenure by freehold three-fifths, church, collegiate, and corporate estates one-fifth, and copyhold under lay lords one-fifth.

#### 3. Buildings.

Some noble seats of proprietors. Kent says farm buildings are on too large a scale; "they are always crying out for barn-room, though wheat is preserved cheaper and better on stables;" barns on a farm of 100l. a year that have cost 500l. Coke has expended above 100,000l. on farm houses; barns at Holkham 130 feet long by 30 broad and 30 high, surrounded with sheds for sixty head of cattle; walls of fine white brick, and roof of blue slate. At Lyderstone an immense barn of Coke's, containing the crop of 140 acres. Seven men necessary on the goff or mow, at the unloading of every wagon, and dare not venture to tread the corn for fear of bursting the barn; farmers fond of immense barns. In building Coke has substituted mill lead for ridge tiles to the roofs; copper wards to all locks; front edges of mangers are rollers covered with tin, mangers themselves plated with iron; bottoms of the stall fences of Penryn slate. In building walls not to be roofed, they are drawn in to a brick's length at top. Lime-wash used as a preservative to boards, walls, &c.: it is composed of lime fresh from the kiln, and clean sharp sand, mixed with hot water, and laid on by a trowel. It is so as always to lay on sand with the lime. An excellent plan. At Holkham a brick manufactory, where bricks of all forms are made, and common bricks are cut, five parts in six, through in various directions, so as to give half and quarter bricks, angles, &c. without breaking and waste. This is one of the most complete manufactories in the kingdom. At Bevington a capital farmery, laborers' cottages and gardens. Sharp clean sand dashed on new paint found to answer the end of imitating stone, &c. A Young did not see a good farm yard in the county.

Cottages much wanted; some built of flint-work.

#### 4. Occupation.

Farms large on the dry soils and smaller on the wet ones; 2000 acres arable in the largest measuring from 400 to 600. Farmers famous for their improvements, excellency of their management, and the hospitable manner in which they live, and receive their friends and strangers. The farming-mind of the county has undergone two revolutions, one between 1730 to 1760, when great improvements were made, and the next about 1790, when drilling began to be introduced. Coke began to promote farming, and the South Down sheep were introduced about that time. The great improvements for seventy years past effected in consequence of twenty-one years leases. The advantages of leases ably advocated by Kent. Coke adheres steadily to this term, while some others are reducing it to seven and nine years.

#### 5. Implements.

For more than half a century these remained stationary; now improvements making; Norfolk plough has a high pitched beam, wheels near to the share, and is reckoned lighter than most wheel ploughs.

#### 6. Enclosures.

Many since middle of eighteenth century. In planting hedges on a loamy soil, the plants being laid in, and the bank over them raised to the usual height, the face of it, and also of the ditch for one foot or more below the original surface is plastered over with loam; stuff taken out of the bottom of the ditch, to the thickness of two or three feet, is, or more about the sets. The advantage of this plan is, that this loamy puddle from the bottom of the ditch, is without the seeds of weeds itself, and by its compactness excluding the air from these in the mould below, it prevents them from germinating;

**7004. OXFORDSHIRE.** An irregular, inland, and in a very backward state as to agriculture. There are rich grass lands, subjected to the same dairy management as in Buckinghamshire, and some natural wood lands. The principal agriculturist and patriot of the county is Fane, of Wormsley. (*Davis's Report*, 1794. *Arthur Young's Oxfordshire*, 1809. *Marshal's Review*, 1813. *Smith's Geological Map*, 1823.)

#### 1. Geographical State and Circumstances.

*Climate*, cold and bleak. On the Chiltern hills, cold, moist, and foggy.

half and three-fourths of its value by hares and pheasants, which are common every where, and on the sand district more especially.

An agricultural society, called the Milford society, meets alternately at Milford and Bury.

the consequence is, hedges planted in this manner require little or no weeding for several years.

#### 7. Arable Land.

Plough with two to four horses very shallow; carefully preserve the hard basis formed by the sole of the plough, which is called the *bed*; and, in so doing, this soil is secured down the riches into the hungry subsoil, &c. Culture of turnips erroneously stated by Kent, to have been introduced from Hanover by Townsend, in the reign of Geo. I.;—doubtless has increased since that period. Clover very general, and wheat on the clover ley; turnips all broad-cast, or if drilled, never on ridgetops, but on the flat surface; rotations good, such as turnips, barley, clover, wheat, &c. Turnips fed off with sheep, or given to cattle in stalls, or the open yard; sometimes carted on the sown wheats in February, and eaten off them by sheep or bullocks, the soil being very dry and loose; clover eaten off, or mown for soiling or hay;—most generally eaten off by ewes and lambs. Wheat dibbled in some places, a practice which originated in this county, and has scarcely been adopted in any other. Carrots not so much cultivated as in Suffolk; a good deal of mustard from March to Wisbeach; on the rich black lands, four crops of mustard taken in succession, and then wheat; produce three to four quarters per acre. Hemp and flax cultivated in the spots of ground belonging to houses of industry, and in some other cases, but to no extent. *Salix* not much cultivated; Coke had 400 acres. Lancers at a few places; mangelwurzel introduced by Sir Mordaunt Martin, who continues to cultivate it. Drilling and dibbling of wheat and pease generally practised on the sandy soils. Coke drills all his corn. Arable culture in every department greatly improved since 1790.—A paper by Kent, entitled *Improving the Soil*, has been justly condemned by Marshal, and other men of more general experience in culture: his notions of shallow ploughing, and continual tillage and cropping without rest, most erroneous, and contrary to experience.

#### 8. Grass.

Very little of natural turf in the county, transplanting turf recently introduced. (5144.)

#### 9. Gardens and Orchards

Orchards to most of the farm houses; some public ones near the towns. Norfolk has an excellent apple, and much used for baking dry in ovens, a very particular operation known only to a few bakers. They are repeatedly taken out of the oven, and pressed flat with the hand, and then put in again.

#### 10. Woods and Plantations.

Much planting has taken place on the poorer sands; Marshal, of Stratton, the chief planter, and next Berney, of Bracon, Coke, and Windham. From 1781 to 1801, Coke planted 715 acres, with upwards of two millions of trees and shrubs, of more than fifty kinds. Bevan, of Riddlesworth, 966,000 trees. Marquis Townshend feeds cattle, sheep, and deer with the trimmings of plantations. Sheep are fond of the bark of the Scotch fir and ash.

#### 11. Improvements.

A good deal of draining done of late years; very little irrigation; among the manures are reckoned marl, lime, gypsum, oyster shells, sea cuse, sea weeds, pond weeds, burnt earth, sticklebacks, oil cake, rape cake, ashes, soot, malt dust, ploughing in growing buck wheat, yard dung, leaves, burning stubbles, river mud, and town manure. Marling, or claying as it is called, has been much used for an unknown length of time, and is found of great use on the sands; laid on at all seasons, but chiefly on the clover leys in autumn, and spread in spring, before ploughing for pease or oats; quantity, twenty to eighty loads an acre; duration, twenty to fifty years. Sea cuse, a calcareous mud, forty loads per acre. The sea mud is chiefly part of a stratum of rotten timber on the sea-shore, and which is washed out by the tides; it is perfectly black and rotten, and ten loads manures an acre. Burnt earth is the burnt ash of the moorhead, and such as comes from the burnt brick, &c. Leaves raked, stubbles burned, &c. by some. Some judicious and successful embankments made on the Ouse, near Lynn, by the late Count Bentick, and continued by his son, the present Governor Bentick.

#### 12. Live Stock.

Predominant cattle Scotch, bought in every year from the drovers, for feeding. Norfolk black legged sheep gradually giving way to South Down's; few on the downs. Poultry good, especially the turkey; owing to the dryness of the soil, and great range of pasture. Decoys, and pigeon houses, formerly numerous, but now on the decline. Rabbits, hares, pheasants, partridges, and rooks abundant.

#### 13. Political Economy.

Chas. II. observed, that Norfolk should be cut into roads for all the rest of England; few canals.

Soil in three great divisions, red land, stonebrash, and chiltern, or chalky hills; the basis of all these soils is calcareous; there is also a considerable portion of loamy soil.

## 2. Property.

Five large estates; church tithes very common, one estate of 20,000*l.* a year, one of 12,000*l.*, one of 7000*l.*, one of 5000*l.*, and so on.

## 3. Buildings.

Blenheim, the noblest in England; Maylands' house, at Broadcourt, recorded by Young, as a model for houses, which cost about 20,000*l.* building. In farm buildings, the best thing is the coped stone rick and granary stands; farm buildings generally of stone, covered with stone slate; wretchedly contrived, and badly executed in most parts of the county. Gardens to most of the cottages. Bishop of Durham has built some very comfortable ones at Mungewell.

## 4. Occupation.

Farms generally smaller than in most other counties; few above 500 acres. Leases of fourteen and twenty-one years not uncommon, many of seven years. Farmers in general very ignorant, and much prejudiced against new practices.

## 5. Implements.

The prevailing plough, a swing wooden board implement, drawn by from three to six horses, and incapable of making good work under the guidance of the best ploughman.

## 6. Arable Land.

Very badly managed in general; on heavy lands two crops and a fallow; in the fallow kept unploughed for the sake of affording couch grass leaves for the sheep. Davis, of Bloxham, an extensive farmer and land-surveyor, "never saw any land upon which a naked fallow is necessary; not even on the stiffest soils," has been in many counties, and employed on twenty-six commissions of enclosure at the same time! Wheat sown early, and either ploughed in or folded; often both. A scantlet of lentils cultivated. Turnips in most parts seldo, bigger than apples. A good deal of sainfoin on the Chiltern, and other calcareous soils, also on the Stonebrash, which is chiefly lime.

## 7. Grass.

Some good meadows near Oxford, on the Thames and Isis; very rich grass land at Thame.

## 8. Woods and Plantations.

Of considerable extent. A great part of the forest of Whichwood belongs to the government. Great attention paid by Duke of Wornsey, to pruning; many beech woods on the Chiltern hills; young wood at Blenheim neglected. The natural forests of Whichwood and Stoken Church, chiefly of beech, but some oak, ash, birch, and aspen.

## 9. Improvements.

Fane, Prat, and Davis, and others, are of opinion, that the agriculture is much superior to what it was thirty years ago, chiefly from the introduction of a better breed of stock, the use of roots and herbage-plants, and the enclosure of commons and common fields.

*Scotch Farming.* In 1809 an attempt was made to improve the estate of Great Tew by letting it to Scotch farmers. As this originated in consequence of a pamphlet which the compiler of the present work published in 1808, it might be deemed a defect in this sketch, if the circumstance was passed over without particular notice. It will, no doubt, long be recollected in the county as at least a ruinous project of wild adventurers, this being the very middest term applied to failures in similar cases. At this distance of time, looking back on the matter, as far as the result affected ourselves, with our natural *sans froid*, we shall state our opinion as to the causes of failure. This resulted principally from too great anxiety, both in the landlord and tenants; to reap a large benefit; and secondly, from the general fall of prices both of land and produce, which succeeded to the published report of the Bullion Committee in 1807. Anxiety to increase the rent-roll, induced the landlord to let the whole of his estate of nearly 4000 acres, then under nearly a score of tenants, to two cultivators, instead of trying first the effect of one or two moderate sized farms under the new mode. The same anxiety induced the tenants to offer too high rents, and to attempt a profit by subsetting. Before the estate had been eight months let, it was sold on the new rental for nearly four times the sum at which it was offered for sale, only a year before; but the title not proving satisfactory to the purchaser the purchase was never completed. The landlord became involved in difficulties owing to the expenses of new buildings, roads, drainages, the purchasing up of certain outgoings, and other

7005. BERKSHIRE. One of the most beautiful counties of England; occupies a surface of 474,000 acres, of which about 200,000 are enclosed, or in parks or plantations, 190,000 in common fields and downs, 40,000 in forests, wastes, and commons, and 8977 in roads. Its productions are almost equally corn and stock; it produces a good deal of butter and cheese, and the breed of swine is noted for its excellence. The celebrated Jethro Tull was a yeoman in this county. George III. and E. L. Lovden, Esq. were among its most noted farmers. On the whole it is a county much more indebted to nature than to art. (*Pearce's Berkshire*, 1794. *Mavor's Report*, 1808. *Marshall's Review*, 1813. *Smith's Geological Map*, 1821.)

## 1. Geographical State and Circumstances.

*Climate* diversified, but in every part the air pure and salubrious; in elevated situations pure, piercing, and braces by its sharpness; in the vales relieves the weak organs of respiration by its soft and balsamic qualities; no storms known in the county. About Reading, vegetation nearly a fortnight earlier than in some parts of the county.

*Soil*, calcareous in general, but in some places gravel, and in a few clay; vale of the White Horse entirely chalk.

*Minerals.* None excepting chalk, Sarsden stones, a sort of large siliceous pebble, in lumps scattered over the Wiltshire and Berkshire Downs, and frequently used and noted for paving. In the vale of Kennet, considerable stratum of peat formed from prostrate trees and other vegetable bodies, and used for fuel, and also burned for the ashes as a manure. The ashes abound in sulphate of lime.

*Water.* Some artificial lakes for breeding fish. Loveden has one of thirty acres, and a "fish-house" or cottage, with an apartment, in which are three stews with covers, which lock so as to prevent even the cottager from stealing the fish. Many gentlemen have ponds, which are let to tenants, and produce a crop, if it may be so termed, every third or fourth year, of carp and tench. The occupier stocks with yearlings about two inches long, obtained chiefly from Yately, on the neighboring confines of Hampshire. The breeders are about eight or nine

causes; he found that though one person had been willing to buy the estate held on twenty-one years' leases, yet that it would sell much better held at will; and was thence induced to buy up from the Scotch tenants the leases granted them two years before; and was still unsuccessful in endeavoring to sell the estate, as the proprietor had himself, with the greater part of his lands in hand, and one farm, it is proper to observe, was put under the management of an Irishman, who rendered himself notorious by some parts of his conduct, and finally left the country clandestinely; and whose actions have unfortunately often been confounded with those of the Scotch farmers. When peace was concluded in 1814, land fell still lower, and finally this estate was sold for less than half its value. It was sold for in 1809; but still (which may be considered as remarkable), for about double what was asked for it in 1807. It is now (1825), probably not worth a third part of what was given for it by the purchaser, from the change in the times; so that even at the original scheme and sale worked well, it is probable that by this time both landlord and tenants would have been ruined, for more money might have been raised by mortgage on such an estate in 1810 than it would have sold for in 1820. The depreciation of the estate has been attributed to the breaking up of old turf, a most unfounded error, as there were not 1000 acres to break up, and of them only 250 were ploughed, and, as would have been proved had the convertible system been continued a few years, greatly to the benefit of the whole. We regret that the landlord, a most amiable and patriotic man, should have suffered in this business; but he entered into it aware that he was incurring an extraordinary chance of loss for an extraordinary chance of benefit, and of course he takes the result as every man ought to do. Besides he has still a very handsome fortune.

*As a trait of the spirit of the Board of Agriculture at this time* we may mention that Arthur Young examined the estate a few weeks after it was sold at so high a rate; and drew up a remarkable report (a MS. copy of which, from his office, is in our possession) in favor of Scotch farming, which was published in the first edition of Sir John Sinclair's *Husbandry of Scotland*. In that report a disingenuous attempt is made to attribute to the Board the merit of the introduction of Scotch farming into this and other counties; whereas it was and is perfectly well known, that the Farmer's Magazine, the Scotch Farmer's Journal, late of Wiltshire, and our pamphlet, were the true causes. A general account of all the operations on Tew estate by Scotch Farmers, and a general account in *Designs and Descriptions of Holdings in the Scotch Style*, adapted to England, &c. 4to. 1812.

## 10. Live Stock.

There is a good deal of dairying in the county; the permanent grass lands being chiefly occupied in this way. The practices are almost entirely the same as in Buckinghamshire. The butter is taken to London by waggons from all the principal towns. Much good dairying at Atterbury, A. Young asked John Wilson, of that neighbourhood, if he ever fed on straw; answer, "No; it *straw* be a good thing to lay on." Sheep, the Berkshire, Gloucester, Wiltshire, Leicester, and other hardy breeds. Fane has tried crossing the Rylands and South Downs with Merinos; several other proprietors of farms have also tried Down Merinos and other crosses, and some the pure breed.

## 11. Political Economy.

Forty years ago roads "formidable to the bones of all who travelled on wheels," now they are much changed for the better. Birmingham canal, and the Thames and Oxford canals, of immense importance to Oxfordshire. A good deal of wool formerly woven into blankets at Witney; now very little. About the beginning of the last century the manufacture of polished steel was introduced at Woodstock, and flourished for half a century; at present nearly extinct. Steel chains have been made here weighing only two ounces, and sold for 17*l.* Scissars from five shillings to six shillings. The steel is the best formed from old nails of horse shoes. Leather breeches making, and the latter thrives well: from 360 to 400 dozen of gloves are manufactured weekly.

## 12. Miscellaneous.

Dr. Sillitoe, the late professor of Botany at Oxford, left 20*l.* a year to a professor of Agriculture and Rural Economy, to be established as soon as the *Flores Græcæ* is completed. This will not be for some years.

ponds weight; but in the Berkshire ponds they are never suffered to breed, but are sold off to the inns at Henley and other places, when the ponds are drawn, which is generally once in four years, and weigh at that age about three or four pounds each. The value of land thus stocked cannot average less than about twenty shillings per acre. The ponds are regularly laid empty, and the fish with which they are stocked, which are uniformly carp and tench, are taken out every third or fourth year. The pond is afterwards allowed to lie fallow for the remainder of the summer season, and is again stocked early in the ensuing year with yearling fry of the same species. The ponds in one parish are all subject to an abundance of coarse, bony, insipid fish, denominated Prussian or German. As this species is carefully destroyed, it is wonderful they should increase with the rapidity and universality which they appear to do: every acre of pond, properly stocked and well situated, must produce an annual increase of from eighty to one hundred pounds. If artificially fed, they might be increased still the greater; or less, if the pond is not so situated, or if the manure from the circumjacent lands. By retail, the fish here are generally sold at a shilling per pound; but under particular circumstances they may sometimes be had as low as ten pence.

## 2. State of Property.

Largest estate 800*l.* a year, a field of 5, 6, or 7 *roods*; E. Cra-

ven, and E. L. Loveden, Esq. the largest proprietors; several handsome seats with land not exceeding 100 acres, and many small freeholders and yeomanry. Some curious customs; at Enborne and Caddleshorth manors, belonging to Earl Craven and R. W. Neison, Esq., the widow of a copyholder, guilty of incontinency or marrying again, lost her freebench or life interest, unless she submitted to the ceremony of riding into the court on a black ram, and of repeating some well-known confessional lins. (See *Addison's Spectator*.) In the manor of Great Farthingdon the customary tenant's daughter, on being convicted of incontinency, was to forfeit the sum of forty pence to the lord, or to appear in court, carrying a black sheep on her back, and making confession of her offence in these words: "*Esse porco pudorem posterioris mei*." Many other curious customs.

### 3. Buildings.

Windsor Castle and many fine seats; houses of the yeomanry genteel and elegant: farm houses generally comfortable. Loveden's ample but ill arranged; cottages of the poor generally in a bad state, some present erections better. (See 777.)

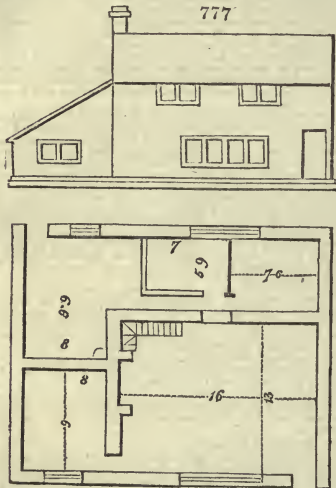

Farmhouses on collegiate or corporate lands generally in bad repair, because the fines for renewal of the leases take all the spare money, &c.

*Cheley Farm*, near Wallingford, in 1800 the property of Lord Kensington, and formerly reputed to be the largest and most compact farm in England. Rent 1000*l.* per annum. Before the dissolution of monasteries it belonged to the Abbot of Reading, who had a seat here. The great barn in which his tithes were deposited is yet standing, and measures 101 yards in length and eighteen in breadth. The side walls are only eight feet high, but the roof rises to a great height, and is supported by seventeen stone pillars, each four yards in circumference. This construction is obviously judicious; high side walls, unless tied together by cross-beams, would have been in danger of being thrust outwards when the barn was filling with corn. This, as we have seen (700*s.*), is the case with the handsome high-walled barns of Coke.

### 4. Occupation.

One-third of the county occupied by proprietors. Farms of all sizes under 1000 or 1200 acres, but few exceeding 500 acres or under 50*l.* a year. Character of the Berkshire farmer stands high. "A hospitable style of living, liberality of sentiment, and independence of principle, are characteristic of the Berkshire farmer; to which he unites persevering industry and integrity in his dealings, which render him worthy of the comforts he enjoys." (*Dr. Mavor*.)

### 5. Implements.

The Berkshire waggon, one of the lightest and best implements of the waggon kind. The sort of draught chain described and recommended by Gray, (261*s.*), is in use on one estate, "the object is to prevent the draught of the tracehorse from pulling down the thiller." The county plough a clumsy implement with wheels; a pressing plough (251*s.*) recently invented; it has three wheels with the tires wedge-shaped, and is intended "to press in the grips or channels made by the common ploughs, that no hollow places may remain for the seed to be buried too deep, &c." This sort of improvement is usual among amateur agriculturists, who have one implement invented to correct the faults of another, both of course bad. A number of other inventions, including a curious hand threshing machine, ingenious enough, but quite unnecessary, are figured and described.

### 6. Arable Land.

Plough generally with four or five horses at a small pace. George III. had two farms, one of 800 acres, cultivated in the Norfolk manner, and another of 450 acres, managed in the English manner; 450 of the former, and 150 of the latter were arable. The whole delegated to the care of N. Kent, of Craigs Court, land-agent, and author of "*Hints to Gentlemen of Landed Property*," 1790. Rye cultivated on His Majesty's farms, and on the Downs. Some hops, woad, flax, and other plants not usually cultivated; seventy acres of lavender at

Park Place, on the side of a chalky hill, originally planted by General Conway, who distilled it himself at his coke manufactory. As the plants die they are replaced by others from a small nursery plantation. It begins to flower about the end of July, when nearly one hundred women and children are employed in cutting off the flower spikes, which they tie up in bundles, and carry to the market, and then carry to the men. The lower part of the stalks are then cut off, and the heads are put into the still, and distilled. The chemical oil, being separated, is poured into copper jars for sale.

### 7. Grass.

About one-fifth of the county under permanent grass, exclusive of the Downs and wastes. A tract of excellent meadow out of the Downs, from the west end of the river, 105 acres, little irrigated, but a good deal flooded after heavy rains. Excellent meadows at Reading; those on the Kennet over the stratum of peat, of rather a coarse quality. Manuring meadows not general, though they are for the most part mown once a year; upland pastures manured when mown. Herbage, plants, and artificial grasses, a good deal sown. Meadows chiefly by oxen after being once mown. The dairy farmers occupy the poorer upland grassy districts, and the breeders of sheep the Downs.

### 8. Gardens and Orchards.

About forty acres of market garden and orchard at Reading, where onions are raised in great quantities; asparagus for the London and Bath markets, and cabbage seeds for the London seedsmen good, apples there and at other places, some clear made, and a good many cherries grown for market. Near Abingdon an orchard of twenty-one acres, containing 541 trees.

### 9. Woods and Plantations.

Extent of Windsor Forest, belonging to the crown, 5454 acres, including wood and water; private property, called Forest Lands, 29,000 acres; encroachments 600 acres. The forest is under the government and superintendance of the Duke of York, lord warden, who appoints his deputy lieutenant, the rangers or head keepers of the several walks, and the under keepers.

Great part of the timber on the forest sold, as well as that retained, is truly venerable and picturesque in appearance, but rotten or mildewed to the heart in such a way as to be fit only for fuel. This rot, or mildew, is called, in the language of the natural process of decay, and is particularly fatal to beech trees, which are by no means so long lived as the oak, ash, and others. Various young plantations on different estates, especially those of Loveden, Fische Palmer, Wheehle, &c. Osier beds on the moist parts of the Thames's meadows.

### 10. Improvements.

An account of the culture of Gen. III.'s farms, by Kent, dated 1798, is given us of the greatest national consequence, &c. Oxen are used both in farm and road-work, and the ploughs are the Norfolk wheel plough and the Suffolk iron plough. At a later period the Rotherham plough, and with which two oxen, yoked in collars, will plough, on the light soil of the forest, an acre a day. Draining in the Essex manner a good deal practised; the drains filled with straw, rubbish from brick kilns, wood, cinders, or gravel.

*Peat ashes* is a manure almost peculiar to Berkshire, though they might be obtained by the same process wherever peat of similar quality abounds, and are so obtained in Holland, and the ashes extensively used there, and sometimes shipped to this country. In the year 1746 peat was first burnt in Newbury, by a Thomas Rudd, who at the same time spread the ashes on clovers, for which they have ever since been famous. An acre of peat land at that period sold for 30*l.* it has since sold, according to its quality, for 300*l.* and 400*l.*, and, in one instance, reached about 800*l.* per acre. Over the stratum of peat, which is about five or six feet deep, is a good meadow soil, and under the peat is gravel. The peat varies in color, but the blackest is reckoned the best, and is used for firing, the ashes of which are most esteemed, and have the reddest color. What is burnt for sale, is mixed with turf and other substances, which gives it a pale whitish hue. It is usually dug with a long-handled spade, from the middle of May to the end of June, and is conveyed from the spot in little wheelbarrows, to a short distance, where it is spread on the ground, and after lying about a week, the pieces are turned. This being three or four times repeated, a heap is made in the middle of the place where the peat is spread, and in the centre of this heap some very dry peat is put, which being lighted, the fire communicates slowly to the rest of the heap. When it is completely lighted, an additional quantity of peat is put upon the heap, and this operation is continued till the whole is consumed, which generally takes a month or six weeks, as quick burning is not approved of. Rain seldom penetrates deep enough to extinguish the fire. The fire is commonly of a circular form, and rather flat at top. At first it is very small; but at last it is sometimes two or three yards deep and six or seven yards in diameter. The ashes being riddled, are conveyed away in uncovered carts, to a distance sometimes of twenty miles, and put into a house, or under a shed, to keep them from the wet, till they are wanted to be put on the ground.

The usual time of applying *peat ashes* is March and April. They are generally taken in carts, and sown on the ground before or after the seed is sown on the land. The quantity is usually from twelve to fifteen Winchester bushels per acre, according to the soil and crop. It is supposed that too large a quantity would be injurious. For barley, wheat, and peas, they are not in much estimation; but for all sorts of artificial grass, more especially, they are preferred to all other manures. In turn they assist to give the soil a softness, and the artificial grass seeds the farmers reckon on an acre, manured with ashes, producing nearly a ton of hay beyond what it would have yielded without them. The effect is supposed to be of no longer duration than two years. On meadow land, from fifteen to twenty bushels may advantageously be put; they much improve the grass.

### 11. Live Stock.

No particular breed of cattle; long horned most common. A dairying tract in the west of the vale of White Horse; much butter made, and some cheese of the single Gloucester kind. Calves a good deal suckled in some places. Buscot parish famous for cheeses, in the shape of pine apples; they are of most excellent flavor, and sell higher than other pressed into a

wooden mould in the shape of a flower pot, and afterwards suspended from beams, rafters, or pegs, in an airy apartment, in a net, whose meshes indent their surface like a pine apple. Salt is then rubbed over them, or they are steeped in brine; weight, &c. The milk is conveyed from the field to the dairies in what is called a tankard drawn by a horse or ass. (fig. 778.)

779



considered as very hardy, and particularly adapted for the low strong lands, and for folding.

**Horses** of the common heavy black race. Pearce calculated in 1794, that 12,000 horses were kept in Berkshire for the purposes of agriculture, and that one-third of the number might be saved by the use of improved implements; most of the horses are bought from the Northamptonshire breeders; many, after being kept a year or two at work, are sold for the London drays.

**Hogs**, the native breed one of the best in Britain; a cross with the Chinese, now more common than the pure native breed. Wherever there is a dairy, hogs are kept, but they are not counted a profitable stock to be fed with what would fatten cattle or sheep. Carcase chiefly made into bacon; cured in the usual way, and dried in rooms heated with wood or coal. Loveden has a bacon house, heated by a stove and flues. In farm-houses, much is smoke-dried in the chimneys with wood fires, which is supposed to have the best flavor.

**Rabbits** kept in warrens, in one or two places; and one gentleman rears tame rabbits of a pure white, the skins of which sell high for trimmings.

**Poultry**. Near Oakingham, many are crammed for the market, they are put up in a dark place, and crammed with a paste made of barley-meal, onion suet, and some treacle, or coarse sugar, mixed with milk, and are found to be completely ripe in a fortnight. If kept longer, the fever that

*Sheep*, a native breed known as the Berkshire polled, or notts (fig. 779); strongly marked, but in much less repute than formerly; it is now difficult to be met with pure; they are

778

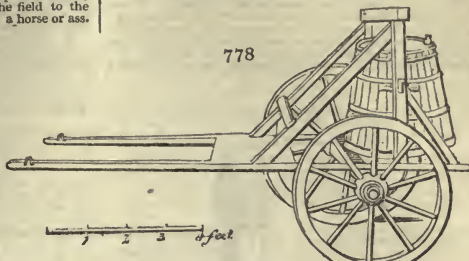

is induced by this continued state of repletion, renders them red and unsaleable, and frequently kills them. In the eastern part of the county, many geese reared on the commons.

**Bees**, not very common. Sir William East, of Hullplace, a celebrated apiarist. In the forest district, bees are most common. One gentleman removes his hives to a heath at the flowering season.

**Deer** kept in several parks; 2500 fallow, and 300 red deer, in Windsor Great Park.

12. Political Economy.

Roads for the most part good, especially since a part has been put under the care of Mr. Adam. Gravel, flint, or chalk, abound in most places. Canals and navigable rivers so interspersed, that no part of the county is further than twelve miles from water carriage. Cloth for sacking and hammocks, manufactured at Abingdon and Maidenhead, also some sail cloth, and rush, and twine matting. Cotton mills at Taplow. Paper, and formerly blankets and other woollens, at Newbury. A parchment manufacture at Oakingham. At Reading, a pin manufactory, and the weaving of galeon, satin, ribbands, and other light fabrics; a floor cloth manufactory; twine and rope making; sail making, sacking, &c.

The Berkshire Agricultural Society, established in 1794.

7006. GLOUCESTERSHIRE. A surface of nearly 800,000 acres, in three natural divisions; the Cotswold hills, the vale of the Severn, and the Forest Lands. Great part of the county is under meadows, pastures, and orchards; and cheese and cider are its known agricultural productions. It is also a manufacturing county, and its fine broad-cloths are celebrated, as well as its iron, tin-plates, and pins. There is no very eminent gentleman agriculturist, nor any agricultural society in the county, but Dr. Tennant farmed a small estate on the Chilterns. (Turner's Report, 1794. Rudge's Report, 1807. Marshal's Review, 1818. Smith's Geological Map, 1821.)

1. Geographical State and Circumstances.

**Climate**, cold and bleak on the Cotswold hills; mild in the vale, which lies open to the south winds; on the sandy soils of the forest district, the harvest is sometimes cut a fortnight earlier than in the vale.

**Soil** of the Cotswolds is all calcareous loam or stonebrash; in the vale, a fine black loam, or fertile red loam, and in some places a strong clay and peat earth; the finest soil is generally sandy loam, sand or peaty earth.

**Minerals**. None in the Cotswolds, but iron and coal in the Forest of Dean, both worked. Lead found in the limestone rocks of the lower part of the vale; not worked. Though iron ore be abundant in the Forest of Dean, only a small quantity raised, it being found more profitable to bring the richer ore of Lancashire, which is burnt with the coke of the forest coal for cast iron, and plates for tinning. Coal pits numerous, and worked at a shallow depth, for want of proper machinery to exhaust the water; three sorts delivered, kitchen coal, smith's coal, and lime coal. Claystone and freestone found in various parts of the forest; paving stones, grindstones, yellow and grey stone tiles raised in different parts of the Cotswolds; gypsum is raised for stuccoing, and sent to Bath from Ilanbury; it is also used as alabaster for chimney pieces, &c.

**Water**. Produce of the Severn is roach, dace, bream, flounders, eels, elvers, chub, carp, trout, and perch. The sea-fish taken within the limits of the county, in the Severn, are salmon, lampreys, lampreys, chad, soles, shrimps, cod, plaice, in great abundance, but now comparatively scarce. Great mischief done by the use of small meshed nets, which take the samlets or fry.

**Ponds for water** made on the Cotswold hills, as already described (4136), in the vale in the common manner. The waters which rise through beds of blue clay, are often strongly saline, as at Cheltenham, &c.

2. Property.

Largest estate 8000l. a year among the nobility, and 3000l. among the gentry; tenures chiefly freehold, some copyhold, and about one-fortieth corporate or ecclesiastical. Estates under the see of Gloucester, leased out on lives; those of the corporation of the city, the same; usual fine for renewal of a life one year and a half of the improved annual value.

Buildings.

Many handsome seats; farm-houses and cottages on the Cotswolds built of freestone, and covered with stone tiles; often as many on an estate of 100l. a year, as are required for a farm of 500l. a year, under the correction of modern improvement; barns, however, of a moderate size; wheat stacked on stone studdles. Cottages, as in most counties, neglected, and uncomfortable; some judicious remarks on the subject by Rudge.

4. Occupation.

Farms differ much in size; few exceed 1000l. or fall short of 50l. a year. Some grazing farms in the vale of 500 acres, but 200 and 300 more common. Leases of three years most common, next of seven years, not many of fourteen, and those of twenty-one on corporate property.

5. Implements.

A narrow-wheeled wagon in general use among farmers. Various ploughs; a short-beamed one-wheel plough in use on the Cotswolds; in the vale, a clumsy swing plough. Lambert's draining plough much in use with the improved draught apparatus, (fig. 730.) and in the old way. Various improved ploughs and other implements, as well as threshing and winnowing machines introduced. A thistle drawer (fig. 254.) in use for extracting the corn thistle (*Serratula arvensis*) from corn fields; cradle scythe used for cutting beans.

6. Enclosing.

The first enclosures during Queen Anne's reign; eleven during the reign of Geo. II.; and upwards of seventy during the reign of Geo. III. Hedges of white thorn, on which the reporter observes medlars might be grafted, and raised in great plenty. Black thorn (*Prunus spinosa*) hedges, he says, never suffer from the blight; a most erroneous idea.

7. Arable Land.

300,000 acres; much ploughing on the Cotswolds lightens the staple of the weak soils: seven horses often used in the vale teams; ridges in the vale so high that a person six feet high may stand in the furrows, and not be able to see the crown of the second ridge from him; to reduce them a small ridge often begun between them. Fallowing practised on the clays, then wheat and beans, or oats. Rotation on the Cotswolds — 1 turneps, 2 barley, 3 and 4 clover mown the first year, 5 wheat, 6 oats, tares, or peas; if oats, frequently laid down with sainfoin. On crumbly soils wheat is sown and ploughed in during rather wet weather, otherwise the seedling plants are apt to be thrown out with the first frosts; the same thing attended to in Oxfordshire and various other counties; this is called seven-field husbandry. Beans either drilled or dibbled; a broad bean, the mazagan, used when the land is in good heart, and ticks when less so. The Burbage pea, an early green variety, most in use. Some lands have the peculiar quality of raising *sideweed peas*, or such as boil freely; on them the Charlton is grown, and sold for splitting; clay lands never have this property. Tares common, and among these a sort called dil, supposed by Marshal to be the *ervum hirsutum*, L., but erroneously termed anethum by Rudge. Turnips on the Cotswolds always broad-cast, and sometimes after wheat or tares, and then called stubble turnips; consumed by sheep in hurdle folds; sometimes given to horses, and found to induce them to eat barn chaff with a better appetite. Some flux

raised; teases a good deal cultivated formerly, now not 100 acres of them in the whole county.

### 8. Grass.

Very rich meadows on the Severn, overflow during winter and spring, on which the farmers depend for a crop. When the salt water overflows, the meadows are termed marshes, and grazed by horses and cattle that require rest and spring physic. In general meadows are mown and pastured alternately, excepting near Gloucester, where abundance of manure is obtained. Herbage, plants, and ryegrass sown on the Cotswolds,

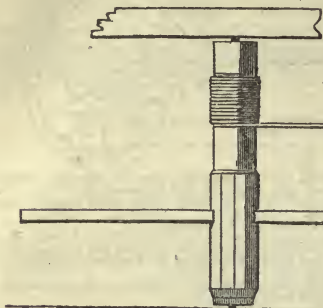

making cider for sale, are found only on the sides of the hills and in the vale and forest district. The stocks are planted in the orchard when six or seven feet high, ten or twelve yards asunder on pasture, and sixteen or seventeen on arable lands. A year after planting, they are grafted. Sometimes fruit trees are planted in the hedge rows, hedges are often composed of apple seedlings, raised from the kernels in the cider mast; and here and there the farmer often leaves a stem to rise above the general height of the hedge, and grafts it; frequently also wildlings are allowed here and there to rise into trees, and their fruit is used with that from grafted trees, in crushing for cider. Grafts are inserted in the cleft manner, at seven feet from the ground, two in each stock: if both succeed, one is removed the following spring, and the stock sloped to the remaining graft, to prevent the lodging of water, and clayed (afresh, to facilitate the growth of bark over the wound. After grafting, "brads," that is, inverted wicker baskets, rising about two feet high, are fitted to the stock, which serve at once to guard the grafts and direct their shoots to a proper form. The stock is next protected from cattle or the plough harness, by four posts placed round it, with six tiers of rails; by three posts and six tiers of rails; by two broad posts and rails; by a bundle of thorn branches; by planting a thorn or briar along with the stock; or by twisting a shoot of the creeping rose (*Rosa arvensis*) round the stock. The mode of planting a creeping rose with the stock, and twisting it round the stem, is said to be found the cheapest and best; but it must evidently impoverish the soil. Pruning is not attended to on young grafted trees, or any others as it ought to be, nor the removal of moss and mistletoe. Grafting the branches of old trees often practised with great success; a young stock grafted will probably not produce a bushel of apples in twenty years, but a branch grafted bears the second year. Dr. Cheston, of Gloucester, practises root grafting, but which is quite unsuitable for field orchards. Grafted trees bear little till twenty years of age; their produce increases till fifty years, and is then ten or fifteen bushels; an apple will bear 100 or more years from this period, and often much longer. A pear tree at Minsterworth 300 years old at least.

**Cider-making.** Best orchardists shake off the fruit, and never beat the tree, which destroys the blossom buds; limb by limb is shaken by a person in the tree, and those which adhere allowed to remain some time longer to ripen: the horse-mill used by large, and the hand-mill by small farmers; the cylinders of the hand-mill of wood, and fluted; sometimes there are two pair of cylinders, one finer fluted under the first pair, and in other cases the cylinders are set wide the first time the apples are passed through, and closer the second; the other processes as usual. Of the various apples grown, the white-styre of the Forest district makes the strongest and richest cider; it is often valued equally with foreign wine, and sold at extravagant prices. Ciders from the Hagloe crab, golden pippin, and Longney russet, are next in esteem. The white-must, wood-cock, and half a dozen others, are fine old fruits, but now going off.

**Perry** from the squash pear is esteemed the best; and next from the Huffcap and sack.

**Table fruits,** where farmers live near canals, pay much better than those of the cider kind; especially those of the keeping varieties, such as the golden and Moreland pippin, Longney russet, &c.

### 10. Woods and Plantations.

Most extensive on the Cotswolds; the sorts there beech and ash; timber sold to dealers, who convert it on the spot to scantling for gun-stocks, saddle-trees, bedsteads, chairs, and other cabinet work, and staves for sugar-hoogsheads. Some fine old specimens of chestnut, elm, oak, and ash in the vale. Tortworth chestnut, 500 years old, in the time of King John. In the Forest of Dean a considerable quantity of good timber belonging to government, and nearly 3000 acres lately planted with acorns. The method of planting is, first, to mark out the ground; then taking off about a foot square of turf, to set two or three acorns with a setting-pin; afterwards to invert the turf upon them, and, by way of raising a fence against hares and rabbits, to plant two or three strong white thorn sets round. They are seldom thinned till they have attained the

size of hop-poles, and then are left at twelve feet distance from each other, with the view of again thinning them, by taking out every other one, when they are thirty years old, and have attained the size of five or six inches diameter. By growing thick, no side-shoots are thrown out, which supercedes the necessity of pruning; the young trees which are drawn at the first thinning, are transplanted, and, as it is thought, grow equally well with those that have not been removed, and produce timber as full at the heart, compact, strong, and durable, as "that which is raised immediately from the acorn." The "whitten" or small leaved lime (*Tilia cordata*, L.), is found in several coppices on the Welsh side of the Severn; and, what is singular, ropes for halters, plough traces, cider presses, draw wells, and fishery boats, &c. are made from it as in Russia. These ropes are found to contract and expand less from moisture or drought than hempen ropes. The bark is stripped off about Midsummer, dried like hay in the sun, and manufactured on the spot or elsewhere. Many walnut trees in the parish of Arlingham; the fruit shipped to distant places, and the timber sent to Birmingham for gun stocks.

### 9. Gardens and Orchards.

Most of the cottages, such as they are, have gardens, and almost every farm its orchard; but large ones, so as to admit of

780

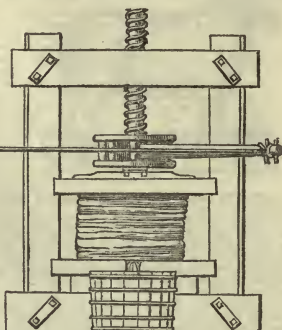

Artificial plantations, to a great extent, made round gentlemen's seats on the Cotswold hills. The osier in beds on the Severn.

**11. Improvements.**

On the lands adjoining the Severn inundations were frequent; but a commission of sewers have erected banks and flood-gates, which protect upwards of 12,000 acres. At other places private banks or flood-gates on the rivers or banked ditches are placed, and operate by the alternate influence of the tides and accumulated inland waters.

**Draining** much practised; both in the turf, stone, wood, straw, and with Lumbert's plough; the plough drawn by twelve horses, or worked by a long lever and axle (2524.), by which one horse gains the power of thirty. Before the mole draining-plough is used, it is a good practice to turn off the sward with the common plough; then to make the incision for the drain in the centre of this; the sward being afterwards turned back to its place, completely covers the aperture, and protects it from the effects of a subsequent dry season. The long-continued drought of the summer of 1806 opened many drains which were cut by Lumbert's plough, so much that the bottom was clearly seen, while many that have been done by hand have formed still wider chasins, and will probably not answer the purpose intended at all. In both instances there is reason to think, that this would not have happened if the operation had been performed in autumn, and the surface turf first turned back, as recommended.

**The accumulated water of underground drains** raised from low meadows in one parish by a wheel driven by the water of surface ditches.

**Paring and burning** practised on the Cotswolds; weeding corn general.

**Irrigation** chiefly pursued in the valleys of the Cotswolds, adjoining rivulets, and especially the Coln and Churn. Carried to greatest perfection in the parish of South Cerney; first began here under the Rev. W. Wright, who wrote several tracts on the subject. When the first great rains in November bring the waters down in a muddy state, it is let into the meadows. In December and January the land is kept sheltered by the waters from the severity of frosty nights; but every ten days, or thereabouts, the water is let entirely off, to give air and prevent the roots from rotting. In February great care is required. If the water now remains long on the meadows, a white scum will generate, which is found to be very injurious to the grass. On the other hand, if it be taken off, and the land exposed to a severe frosty night, without being previously dried for a whole day, much of the tender grass will be cut off. Towards the middle of this month less water is used than before, keeping the land rather wet than watered. At the beginning of March, there is generally in such meadows plenty of pasture for all kinds of stock; the water, however, should be taken off nearly a week before cattle are turned on, and a little hay at night during the first week is very proper. It is the custom with some to spring-feed with ewes and lambs folded, with a little hay. The meadows, however, must be en-

tirely clear of stock by the latter end of April. If May be at all intruded on, the hay crop will be much injured, and the grass become soft and woolly, like lathemath. After spring-feeding the water is let in again for a few days. It is remarked, that autumnal, winter, and spring watering will not occasion rot in sheep; but if the water be used for a few days in any of the summer months, the pasturage becomes unsafe for such stock. This is conformable to the general idea of rot; viz. that it is occasioned by summer-moisture, and is seldom known to any considerable extent without a long continuance of warmth and rain. A wet summer, therefore, is always productive of this disease in the vale. The general advantages of watering are, that the land and herbage are continually improving, without manure; and the crop is not only full and certain, but also early.

Warping might be practised to a considerable extent on the banks of the Severn, if the commissioners were to direct their attention to the subject.

12. Live Stock.

The dairy the principal object with most of the vale farmers. Good milkers preferred, without much regard to perfection of shape. Gloucestershire breed resembles the Glamorganshire excepting in color, which is red or brown, bones fine, horns of middling length, white with a black tip at the ends, under thin in flesh and large. In the higher vale the improved long horned cows of Bakewell and Fowler in most prefer. Devons, Herefords, and various others in use. The bull and doe not always produce the most marketable cheese; often times the reverse; if it has either been much manured with dung, or sheep feeding, the quantity of milk will be increased, but the quality materially altered. This is probably owing to the introduction of plants, which did not grow there before, or to the destruction of some that did. The cause does not originate with the cow, but the herbage on which she feeds. The same cow, on two pastures, separately, and by the hedge, will give milk of different qualities: from one shall be made fine, rich, and close cheese; while from the other shall be made rank, "heaving," hollow, unpleasant to the palate, and unfit for the market. In the parish of Haresfield, two grounds adjoining each other were alternately used for the pasture of cows; while the one, an excellent cheese was made; but on the other, it was difficult to make any tolerably good. The latter had been lately well dressed with manure, which produced plants unfavorable to the dairy; and the dairy woman herself remarked, that if the farmer continued to enrich the herbage with dung, she must give up making cheese. It is

proper, therefore, that milking-cows should not be removed from one pasture to another indiscriminately, but that certain grounds, in proportion to the stock, should be assigned to their use; and this is the practice on many farms where cow-pastures have for time immemorial been appropriated exclusively to the use of the dairy. The dung of the cow, indeed, being of a cooling nature, is the best manure for cow-pastures. Other animals, such as colts and sheep, may occasionally be let in to eat the refuse grass, but not more than one sheep should be allowed to an acre. Among the plants which are useless, or unfavorable to the making of good cheese, are white clover (*Trifolium repens*), the different kinds of crow-foot (*Ranunculus*), and garlic (*Allium*). White clover is brought forward by many as a proof of good land, and is a proof of good land, in all of land in a state of high cultivation; hence it has a tendency to raise the quality of the milk, and make the cheese heavy.

Cheese-making. Best cheese not attempted while the cows are on hay; generally commences about May, when the cows are turned into the pastures. Cows milked twice a day, at four in the morning, and at the same hour in the afternoon; the cheese-factor discovers the "hoved" cheeses by treading on them.

Sheep. Principal breed the Cotswolds; now very much mixed by crosses with the Leicester and South Downs. The liver rot common in the vale, and therefore few bred there. Wiltshires are bred in and fed off.

Horses, no particular breed.

Pigeons, formerly numerous, now on the decrease.

13. Political Economy.

On the hilly districts, where stone abounds, the roads greatly improved of late; those under M'Adam excellent; but the vale roads in many places very bad. Manufacture of woollen broad-cloths, chiefly superfine from Spanish wool, extensively carried on in the district called the Bottoms. Carpet weaving and thin stuffs at Cirencester; stocking frame knitting at Tewkesbury; wire, cards, rugs, blankets, iron and brass wire, tin plate, pins, writing paper, felt hats, manufactured at different places. Spinning of flax the winter work of women in the vale of Evesham. Extensive iron works in the forest; the best iron in the kingdom made at Huxley; nails made at Little-dean. Articles of agricultural commerce, cheese, lincon, cider, perry, grain, and salmon, to the extent of 40000l. per annum; in manufacturing commerce, broad-cloths and pins are of the greatest importance.

707. WORCESTERSHIRE. A surface of 500,000 acres, distinguished by the two extensive vales of Worcester and Evesham. In the fertility of its soil, and the amenity of its situation, surface, and natural embellishments, very few districts of similar extent are equal to it—scarcely one excels it. And its more various, than those of other counties; not corn, cattle, and dairy produce only, but fruits, liquors, and hops, rank among its productions. (Pomeroy's *Worcestershire*, 1794. *Pitt's Report*, 1807. *Marshall's Review*, 1818.)

1. Geographical State and Circumstances.

Climate of the middle, south, and west of the county, remarkably mild, soft, and salubrious; the vales of the Severn, Avon, and Teme, with the contiguous uplands, rising to 150 feet above their level, ripen their products from a fortnight to a month earlier than what takes place in elevated countries even with a similar soil and surface; sixty yards perpendicular on one degree more to the north, conformably to the idea, early at Worcester, and late at Birmingham. Apparently much less rain falls here, than in counties more elevated and more inland.

Soil. Ten thousand acres of deep rich sediment deposited by the Severn, and a good deal on the Avon, Teme, and Stour; half the rest of the county, rich clay and loam; some light sandy soils about Kidderminster, and springy gravel about Bromsgrove.

Minerals. Brick-clay, gravel, sand, marl, freestone, coal, at Mambie; quartzen, a siliceous stone, forms the basis of the Malvern hills. Excellent common salt at Droitwich.

Water. Rivers, but no lake, pool, or pond formed by nature. Malvern well, a good chalybeate; it is limpid, without smell or taste.

Fish in the Severn, salmon, shad, lamprey, and lampern; the lamprey grows to twenty-six inches long, and is often three or four pounds weight; it leaves the sea in the spring, and is esteemed a great delicacy, but unwholesome when eaten too freely. The lampern goes to the sea at certain seasons; is ten or twelve inches long, about the size of a man's finger, and common in Worcester, potted or preserved; vast quantities sold for baits to the cod fishery.

2. Property.

Variouly divided among all classes; many resident families of considerable opulence and fortune.

3. Buildings.

Some magnificent residences; farm-houses erected at different times, and of a very remarkable, unless for being badly situated and arranged; great want of convenient dwellings. Cottages have nothing to recommend them; often built of timber and plaster, and covered with thatch. Some good stone bridges over the Severn, and an iron one of an arch, 150 feet span and fifty feet rise, at Stourport.

4. Occupation.

Farms small, from 40l. to 400l. a year, but some larger; seldom held on lease; but when a tenant takes a farm on strong lands, where the course is fallow and two crops, he holds it by custom for four years. Knight, of Lea Castle, farms 350 acres in a mastery style; large farmers have a turn for improvement; small ones have seldom an opportunity; many inventions proposed and introduced, and the sensible farmer unfortunately finds few of them that will answer.

Picturesque Farming by Knight. About 200 acres around Lea Castle, formerly in the hands of about a dozen, but now divided into six, are now laid, or laying together, the roads better disposed both for convenience and appearance, and the hedges stocked up; but the trees, which are in abundance, carefully preserved, to give a park-like appearance; this is divided into lots by temporary hurdles.

Military Farming. The same gentleman, when the volunteer cavalry were raised, sold his heavy farm horses, and

bought light ones, chiefly Clevelands, on which he mounted ten of his own servants for military service. The horses doing all the farm work, and occasionally serving for saddle horses, or to draw his carriage.

5. Implements.

Plough two-wheeled, and drawn by three horses in a line, walking in the furrow; in the vale of Evesham, a heavy swing plough; these ploughs are seen no where else; they are all wood, excepting the share and coulter; very long in the tail, throat, and sideboard; a load for a team; the four-wheeled trolley is a low wagon, used for harvest work. Knight uses improved implements, and ploughs with two horses a breast. Various drills for sowing wheat, and stirring the soil between the rows (fig. 74.), manufactured at Evesham, and used in the neighborhood.

781

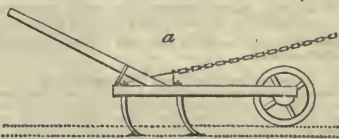

6. Arable Land.

Fallows ploughed four times, which is rather rare in England; rotations generally a fallow and two corn crops, with an intervening leguminous herbage, or turnip crop. Drilling in use for wheat, in the vale of Evesham and other places; beans commonly dibbled. Turnips cultivated broad-cast, and Carpenter, author of *A Treatise on Practical and Experimental Agriculture*, has discovered since he published his book, that the fly is to be prevented or destroyed by steeping the seed in sulphur before sowing, and harrowing as soon as the fly is discovered, "then sow eight bushels per acre, of dry lime, or fine ashes, when the dew is on the leaves, so as it may adhere to them." Carrots sown by Knight and others in the neighborhood, where a good deal of seed is raised for the London seedsmen.

Hops grown to great perfection, and fruit trees generally planted among them at the rate of forty-eight to an acre; 1000 stools of hops are considered an acre, whatever ground they may stand on, and labor is paid for accordingly. Golding-vine, mation-white, red, nonpareil, and Kentish grape, local names for varieties distinguished by very slender shades. Land stirred between the plants with the plough; only two weeks to be taken in kind, the parson may either take every tenth basket when green, or every tenth sack when dried; in the latter case, allowing 25s. per cwt. for drying, sacking, and duty. The culture of hops having been carried too far, the trade here, as elsewhere, is on the decline; corn, on the average of years, is found to pay better.

Asparagus, cucumbers, and onions, grown in the fields of

Evesham, and sent to Birmingham market, though thirty miles distant; also, poppy-heads for the London druggists. Clover for seed in various parts of the county.

#### 7. Grass.

The banks of the rivers chiefly under meadow of the very richest kind; employed chiefly in fattening cattle and sheep; clovers and rye grass cultivated.

#### 8. Gardens and Orchards.

Market gardens near most of the principal towns; produce, besides local consumption, is sent to Bath, Bristol, and Birmingham. Orchards, long and successfully cultivated in the middle, south, and western parts of the county; round towns, villages, and farm-houses; and all the hedge-rows of a farm often planted with fruit trees, and very productive. In a plentiful year, or what is called a "hit of fruit", it will not pay for carriage to market from remote places; no casks can be got for all the juice. In 1784, cisterns were formed in the ground to receive the liquor, but they ran out; in Pershore, it is said currents of perry ran into the common sewers. Large quantities of apples rot, or are denuded by hogs; cider in such a year sold for 21s. a hogshead, in Worcester market; two or three tons of cherries often sold in Worcester market in the morning before five o'clock; six tons have been sold there in one morning; 2000*l.* has been paid for the tonnage of fruit on the Trent and Severn canal in one year; canal forty-six miles long, tonnage 13*d.* per ton per mile; 7000 tons must therefore have passed. The stocks are not grafted here till three years after planting out, and saddle-grafting of a peculiar kind, (fig. 782.) is preferred to the cleft manner used in Gloucestershire. Sometimes the boughs of the stock are each grafted in the whip manner. When cleft-grafting is performed, the cleft is made with a saw, and afterwards smoothed with a knife; little care paid to the trees afterwards; they bear at five years, are at perfection at thirty, and continue in full bearing for at least thirty years more. Sheep should be excluded from the orchards, and coarse grass or straw burned in them on the first appearance of a blight; this fumigation destroys myriads of insects. Fruit is gathered as it falls from the tree; no force used till the leaves are mostly fallen, and then only shaking or striking with a light pole. Cider made as in Gloucestershire, but with large weeds, and some farmers propose to separate the core and kernels from the pulp, by forcing a cutting cylinder through each apple, and then grinding the core and pulp apart, as much of the flavor of cider depends on bruising the seeds.

#### 9. Woods and Plantations.

Abundance of oak and elm. Croome, Hagley, &c. well-wooded. Forest of Wire, near Bewdley, supplies oak poles, rails, hurdles, laths, hoops, &c.

#### 10. Improvements.

Earl of Coventry drains his park by open cuts wide, and their sides turfed to the bottom; all the attention they require is preventing the establishment of large weeds, or coarse tufts of grass, which would interrupt the water; some embankments on the Severn, and some meadows irrigated, but mostly by floods.

7008. MONMOUTHSHIRE. A surface of 316,800 acres varied by hills, some of which are of considerable height; more distinguished by its woods and the coal basin of South Wales a fund of wealth of immense consequence to Britain, extends into Monmouthshire, and, with the iron works, forms an important source of industry and wealth. (Hassall's Report, 1811.)

#### 1. Geographical State and Circumstances.

*Climate.* Mild in the vales and cold on the confines of Breconshire, where the snows sometimes remain on the ground till a late period in spring; atmosphere humid, as in most western counties; highly favorable to the growth of grass.

*Soil.* Clay, loam, and grey soil on rock or marble, and beds of limestone. Caldicot and Wentlog levels on the Severn; and the court of sewers is a rich silt loam. Soil of the hills a reddish loam. No poor soil in the county.

*Minerals.* Coal, iron, and lime. Upwards of twenty iron works in the coal district; coal not brought into general use till 1792, when the canals and railroads were completed. Principal proprietors of the mineral district, Sir Chas. Morgan, C. Leigh, Esq., B. Hall, Esq., and the Earl of Abergavenny. A particular description of the mineral basin of South Wales given by Martin (*Phil. Tran.* 1806).

#### 2. Property.

Duke of Beaufort and Sir Chas. Morgan the chief proprietors; next class, 1000*l.* to 3000*l.* a year; a third class, 300*l.* to 1000*l.* a year. Many proprietors occupy a part of their estates, and cultivate them well; some very small portions of orchards and grass lands.

#### 3. Buildings.

Some fine old seats; farm-houses of the oldest date, timber statched; new ones covered with tile-stone; seldom any farm yards; but cattle-houses, and barns scattered about at random; cottages on the most frugal plan, generally with a garden.

#### 4. Occupation.

Size of farms, sixty to 800 acres; 140 acres about the average; leases not very general.

#### 11. Live Stock.

No particular breeds; land too good for breeding; feeding chiefly attended to, and some dairying; some soiling, and a good deal of oil-cake used for finishing autumn-fed oxen. Mules used in agriculture in some parts of the county, especially near Bewdley; rise to fifteen hands or more; Skays range mainly bred from grey or white mares and a white spotted foreign ass. The great age to which they attain is one of their chief advantages; at perfection at thirty, and work till seventy or upwards. Asses employed by Carpenter, of Bromsgrove, farmer and author.

#### 12. Political Economy.

Principal roads good, cross-roads very bad. A road club, established in the vale of Evesham in 1792, the members of which bind themselves to become road surveyors, gratis, in their turns, and strictly to enforce all laws, and to take all the means in their power for procuring and keeping good roads; several canals, fairs, and markets. Manufactures of gloves in Worcester, and also of porcelain and cabinet furniture: of woollen cloth and glass at Stourbridge; of glass and pottery at Dudley; leather-making from sheep skins at the same place; nails, needles, linen, wool-combing and spinning at Bromsgrove and Redditch; tanning in most places; carpets at Kidderminster; various iron works on the Stour; stocking frames at Tewkesbury and Brecon.

*Droitwich salt works* on record from 816. The strata over the woollen cloth and glass at Stourbridge, of which exported abroad, in April 5, 1772, 604,579 bushels; of which exported abroad, 110,120 bushels. Duty paid into the salt-office, London, 61,457*l.* which was then nearly one-third of the whole revenue from salt in England. The process of making salt at Droitwich is as follows:—A little common water is first put into the pan, to keep the brine from burning to the bottom; the pan is then filled with brine, and a small piece of resin thrown in to make it granulate fine; when the brine is boiling, the salt first incrusts at the top, and then subsides to the bottom; when subsided, the persons employed ladle it out with an iron skimmer, and put it into wicker barrows, each containing about half a bushel, in the shape of a sugar loaf, and let them stand at the side of the pan for some minutes to drain; they then drop the salt out of the barrow, and place it in the stove to harden. In 1775, Baker, a druggist, from London, spent 12,000*l.* in a project for conveying the Droitwich brine in pipes to the Severn, without success. Dr. Nash, from experiment, believes Droitwich salt to be neither manure in itself, nor capable of exciting any vegetative principle on the earth, as animal or vegetable salts, or lime may do; it produces bad effects on ploughed lands, by increasing their dryness in hot weather, and by making them greasy, and what the farmers call raw, in damp weather. He has found it serviceable to scatter foul salt upon large heaps of manure, to kill weeds and destroy their seeds, but not to enrich; care must be taken that it be not laid near the roots of the trees, as it will certainly destroy them. If laid at the bottom of pools, it enables them to hold water; it is wholesome to granivorous and granivorous animals, but prejudicial to carnivorous ones.

#### 13. Means of Improvement.

The establishment of village and parish libraries recommended; and a paper on the subject copied, which appeared in the Worcester newspaper. From the books recommended, as well as other evidence, the writer of this paper is Sir Richard Phillips. The plan is excellent, and would probably, in the course of a generation, effect a complete change in the lower classes of society. Le Couteur's treatise on apple trees and cider, as applicable to the Isle of Jersey, appended to the survey.

#### 5. Implements.

The proprietors of iron works have introduced many improved forms from the north; very neat iron gates and posts. (fig. 783.)

#### 6. Arable Land.

Less than the pasture; tillage chiefly by oxen. "Many farmers are so circumstanced, as to be ever on the watch, lest the avarice of their landlords should interfere with their industry, by being unwilling any improvement they make in the soil, and unexpectedly raise the rent. The such unfair dealing is become too frequent, is much to be lamented,

782



783

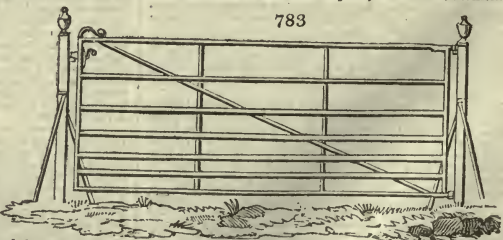

and can only be guarded against by leases."

#### 7. Grass Land.

"Some farmers insist on it that rushes shelter and protect grass, and will not allow them to be removed by draining or otherwise."



### 8. Gardens and Orchards.

The latter very general on the small scale; apples for eating much in demand at the iron mills; best orchards and hop-grounds in the hundred of Italgland.

### 9. Woods and Plantations.

County long famous for the size of its oaks; stock now much diminished.

### 10. Live Stock.

Mixed cattle; some dairying, but feeding more general; Hereford horses a good deal bred; asses and mules in use about the iron works; the mules found better than horses for carrying charcoal from the woods to the iron works.

7009. HEREFORDSHIRE. A surface of 600,000 acres, studded with hills, hillocks, and minor swells of various heights and dimensions; almost every where of a rich soil, devoted exclusively to agriculture, and highly productive in corn, cattle, fruit, cider, hops, and timber. The most distinguished cultivator in the county is T. A. Knight, Esq., known in agriculture by his Treatise on the Apple and Pear, many valuable papers in the Transactions of the Royal Society, and communications to the Board of Agriculture; and in gardening by numerous essays and improvements, and his honorable office of President of the Horticultural Society. (*Clark's Herefordshire*, 1794. *Duncomb's Report*, 1808. *Marshal's Review*, 1818.)

### 1. Geographical State and Circumstances.

*Climate*, remarkably healthy; west winds the coldest; warmest and earliest part about Ross.

*Soil*. A marly clay of great fertility extends over most of the county. The heaviest crops of wheat produced on a clayey tract between Hereford and Ledbury; the lightest lands in the south-east about Wormelov, and known as the "Rye lands," from the prevailing practice there in former times.

*Minerals*. Iron ore in the sandy district, but not manufactured at present. Red and yellow ochre, pipe-clay, and fullers earth, but only the latter worked for.

*Water* abounds; salmon caught in the Wye, but owing to the weirs and illegal practices, not so abundantly as formerly.

### 2. Property.

Guy's Hospital, Duke of Norfolk, Earl of Oxford, Earl of Essex, Sir Cornwallis, and the Bishops. The great estates divided into farms from 200 to 400 acres. A number of estates from 400l. to 1000l. per annum constantly resided on by their owners, and cultivated and managed in good style, with a view to the introduction of the best agricultural practices. The tenures of gavelkind and borough-english exist in a few places, but are generally nullified by will.

### 3. Buildings.

Some fine seats of proprietors, as Home-lacy, Hampton Court, Downton Castle, &c. Old farm-houses of wood, fill designed, and placed: some good new ones on the Guy's Hospital and other estates. Cottages very humble, and of an inferior construction. Strawberries lately cultivated by some cottagers, for the Hereford market, with success and profit.

### 4. Occupation.

Small farms on the decline; few opportunities now by which an industrious couple can devote 50l. or 100l., acquired by personal labor, to stock a few acres, and bring up their family, and pass their latter years in comparative independence. Hence matrimony on the decline, and licentiousness on the increase. Hence Duncombe humanely recommends proprietors to forego the temporary advantages of throwing the whole of their estates into one or two farms, of all sizes, from 5 to 500 acres, as ultimately best for the country. "The old-fashioned farmer of Herefordshire receives any new experiment in agriculture with great hesitation, if not reluctance. When its utility is confirmed by repeated trials, he slowly and gradually falls into the practice; but he wisely leaves the experiment and the risk to those who recommend or suggest it, and happily the county is at this moment well provided with agriculturists, who possess the means and the spirit to undertake the patriotic task." Leases of twenty-one years most commonly in three periods of seven years, determinable at the end of each period by either landlord or tenant.

### 5. Implements.

Plough called the light lammas, without a wheel, and drawn by three or four oxen generally in a line, abreast, but often the yoke is the usual mode of harnessing. Various improved implements by the amateurs, but none in general use.

### 6. Arable Land.

Wheat principal grain cultivated, and generally sown on a fallow. Change of seed procured from the chalk hills of Oxfordshire; steeped in brine and lime, to guard against vermin and smut. Knight, late of Elton, now of Downton Castle, steeped in water and then envelopes in lime, and his wheat was as free from smut and other diseases as that of his neighbors from changed seed. Hops a good deal cultivated, and chiefly disposed of to Bristol dealers.

### 7. Grass.

Fertile meadows on the Wye, Frome, and Lug; mown and fed. Not a dairy county for home consumption, seldom for exterior markets, or Smithfield. Butter supplied from Wales, and cheese from Shropshire and Gloucestershire. "The general soil of Herefordshire appears to be unfavorable to the making of cheese. T. A. Knight, with that accuracy and skill which he is known to possess on all subjects connected with agriculture and natural history, has proved by experiment, that equal quantities of milk in Herefordshire and Cheshire, will produce unequal quantities of curd, highly to the advantage of Cheshire; and further, that better cheese has been produced in that county, from milk, half of which has been previously skimmed, than is produced in this from milk altogether unskimmed. The want, therefore, of complete success in this valuable branch of rural economy is not solely to be attributed to the want of skill in our dairy-maids; and the cause of failure is rendered more difficult of discovery, and consequently more difficult to be remedied, from an observation that the plants were nearly the same in the Herefordshire and Cheshire pastures, on which the above experiments were made: white clover abounded in each, with the crested dog-tail grass, and rye-grass mixed with others in small quantities. Of such plants the pastures of Herefordshire are generally composed.

A mode of managing sound meadows and pastures has lately been tried, and attended with a great increase of produce.

### 11. Political Economy.

Valentine Morris, Esq. of Ptercefield, being examined as to the roads of the county, before Parliament, was asked,—

Q. What sort of roads have you in Monmouthshire?

A. None.

Q. How do you travel then?

A. In ditches.

This was thirty years ago; they are now improved, but still bad; various iron railways and canals.

### 12. Means of Improvement.

Leases; embanking the river meadows; drainage; knowledge.

The grass is mown as soon as it is in blossom, and consequently previous to the formation of seed. The after-grass is not grazed until it begins to contract a yellow appearance, in the latter end of October or beginning of November. In this case the ground remains covered during the winter with a portion of dead herbage, through which the young grass springs with the greatest vigor at an early period of the succeeding spring.

### 8. Gardens and Orchards.

Fruit trees first extensively planted in Herefordshire in the time of Charles I., by Lord Scudamore, of Home Lacy. Orchards and hedge-row trees of the apple and pear kind are found on every aspect, soil, and under every culture. The soil best adapted to most kinds of apples, is a deep rich loam when under the culture of the plough; the Styre and golden-pippin, in particular, form exceptions, and flourish most in a hot and shallow soil, on a lime or sandstone. The best sorts of pear trees also prefer the rich loam, but inferior kinds will even flourish where the soil will scarcely produce herbage. The apples are divided into old and new sorts; each class comprises some called kernel fruits, namely, the fruit growing on its native roots, as a distinction from those produced by the operation of grafting. The old sorts of apples are those which have been first introduced, such as the Styre, golden pippin, hagioe-crab; several varieties of the Harvey; the brandy apple, red-streak, woodcock, moyle, genet, red, white, and yellow musks; fox whelp, loam, and old pearmain; dymock red, ten commandments, and others. Some of these names are descriptive of the fruit, and others are derived from the places where they have been first found, or found in most abundance. The old pears held in most estimation are, the squash, so called from the tenderness of its pulp; the oldfield, from having grown as a seedling in a field of that name; the huffcap, from the quantity of fixed air contained in its liquor; the bar-land, from fields in the parish of Restbury, called the Barlands; and sack-pear, from its richness; and the red pear, from its color. Of more common sorts, the long-land is the most valuable, and for the general use of the farmer perhaps the best of any.

### 9. Woods and Plantations.

Oak very abundant, and more rapid in its growth in this county and Monmouthshire than in most parts of England. Lord Oxford's estates and Croft Castle contain the finest old trees in the county; fine woods at Foxes, U. Price, Esq.; most luxuriant oak and coppice at Moccas Court and Stock Park; a curious weeping oak at Moccas. Most productive ash coppices at Hampton Court and Ledbury; cut every thirteen years for crat ware, hurdles, &c. and bring from 18l. to 35l. per wood acre, which is to the statute acre as 8 to 5. Elm trees are interspersed in the hedge-rows with fruit trees.

### 10. Improvements.

Draining much wanted, but practised chiefly by proprietors; watered little practised, though introduced in 1641 by R. Vaughan, Esq. of New Court, whose tract on the subject has been already mentioned. (4054.) One of the greatest experiments in this way which has been attempted of late years in Herefordshire, has been attended with complete success on the estate of T. A. Knight. By making a wear on the river Teme, with proper courses for the water, that gentleman is now enabled to irrigate two hundred acres of land, which were never watered before, with the assistance of the least flood; and one half of that quantity even in the driest season.

### 11. Live Stock.

Hereford cattle esteemed superior to most, if not to all, other breeds; those of Devon and Sussex nearest them in appearance. Large size, an athletic form, and unusual neatness, characterize the true sort; the prevailing color is a reddish brown with white faces. The rising of oxen for agricultural purposes universally prevails; nearly half the ploughing is performed by them, and they take an equal share in the labors of the harvest. They are shod with iron in situations which frequently require their exertions on hard roads. The show of oxen in thriving condition at the Michaelmas fair in Hereford, cannot be excelled by any similar annual contest in England; on this occasion, they are generally sold to the principal graziers in the counties near the metropolis, and there perfected for the London markets.

Herefordshire not being a dairying county, breeders direct their attention to producing that form of animal best adapted for feeding rather than milking. "The whole attention of the Leicestershire breeder has been directed to the improvement of his cow; and for the use of the grazier, he has made her an excellent animal. The Herefordshire breeder, on the contrary, has sacrificed the qualities of the cow to those of the ox; he does not value his cow according to the price which the grazier will give for it, but in proportion as it possesses that form and character which experience has taught him to be conducive to the excellence of the future ox. Hence the cow of Herefordshire is comparatively small, extremely delicate, and very feminine in its characters. It is light-fleshed when in common condition, but capable of extending itself univer-

sally in a short space of time, when fattening. Experience seems fully to have proved, that these qualities in the cow are necessary to perfection in the ox; and that when the cow is large and masculine in its character, and heavily loaded with flesh, the ox will be coarse and brawny, and, consequently, unkind and tedious in the process of fattening. It may here be remarked, that there is an extraordinary difference between the weight of a Herefordshire cow and the ox bred from her; perhaps other sorts, eminent for producing fine oxen, are similarly distinguished; but it is a fact, that a Herefordshire cow will not unfrequently be the mother of an ox of nearly three times her own weight. T. A. Knight, who made this observation, recollects no instance of this great disproportion in the weight of the males and females of the long-horned cattle. That gentleman farther observes, that he is unable to discover what advantage the public have derived, or are likely to derive, from a breed of cattle which are neither calculated for the dairy nor for breeding oxen. The difference in the dairy between a good and an indifferent milking cow, on the pasture which is adequate to the keep of the latter, will seldom exceed five pounds, and if the animal be good, a very poor pasture will be sufficient; but the difference between a good and bad ox will often exceed twenty pounds, where both have consumed in fattening equal quantities of food: individuals and the public are, therefore, equally and evidently interested in the improvement of the laboring ox. Persons of little experience, Knight adds, in the breeding of cattle, may perhaps think that a sort is obtainable which will unite the two objects; but experience will convince them, that in endeavoring to approach two opposite points at the same time, they will never be able to reach either. Where the soil is well calculated for the dairy, every attention should be paid to obtain and improve the best sorts of milking cows; and where the ox is kept to a proper age as a beast of draught, nothing conducing to his excellence ought to be neglected. A cow

must, however, give milk enough to keep its calf fat, or it is disqualified for breeding a good ox, because the calf would be spoiled before it had acquired the proper age to be weaned.  
**Sheep.** The provincial breed, the Ryeland, named from the sandy district in the neighborhood of Ross. They lamb in February and March; but during winter, and particularly in time of lambing, the store flocks are generally confined by night in a covered building, provincially termed a cot, in which they are sometimes fed with hay and barley straw, but much more frequently with peas-haulm. Some breeders accustom them to the cot only in very severe weather, and in lambing time. The practice was derived from the Flemings, and introduced into England about the year 1660. A cross has been made between the Ryelands and the new Leicester sorts, to the advantage, perhaps, of the breeder who is situated on good land, but certainly to the detriment of the wool. A cross between the Ryeland and real Spanish seems the most probable mode of adding to its fineness and value. Dr. Parry's experiments have been already related. (6490.)

12. *Rural Economy.*  
 "If a certain proportion between the price of labor and the average price of wheat, could be fixed by law, so as to render the applications for parohhal aid necessary only in cases of a very large family, of unusual illness, of scanty seasons, or any other real emergency; the measure, it is presumed, would be honorable to the country, would stimulate industry and fidelity, would check dishonesty, and endeavor to a numerous class their native soil."  
 13. *Political Economy.*  
 Roads formerly bad; now improving; materials, coarse limestone. Gloves, to a small extent, manufactured in Hereford. An agricultural society established in 1797, which has given many premiums, and done much good.

7010. SHROPSHIRE. A surface of 890,000 acres; in general flat, but with hills of considerable height on some of its margins. The soil is chiefly clay, but in part light turnip land; both are devoted to the raising of corn-crops. Breeding and dairying is also practised to a moderate extent. The greatest improver in the county is the Marquess of Stafford, whose extensive and important operations on the estate of Lilleshall are described at length by Loch, in his *Improvements on the Marquiss of Stafford's Estates*, 1819. (*Bishton's Shropshire*, 1794. *Plymley's Shropshire*, 1801. *Marshal's Review*, 1819.)

1. *Geographical State and Circumstances.*  
*Climate.* Considerable difference according to the soil and surface; more warm on the eastern side than in the middle of the county. E. winds prevail in spring, and W. in autumn.  
*Soil.* Nearly an equal quantity of wheat and turnip land, the former rather predominant. S.W. side of the county variable; thin soil upon clay or rock; extensive tracts of hills and waste; and most sorts of soils except chalk and flint.  
*Minerals.* Lead in granulated quartz very productive. Copper ore found but not worked. Coal of excellent quality on the eastern side of the county; lime, building-stone, chalybeate, and spa waters, at different places. At Kingly Wick a spring of salt water, used for making soda at a work established at Wormbridge.

*Waters.* Twenty-two sorts of fish found in the Severn in Shropshire. Salmon in season from Michaelmas to May.  
 2. *Property.*  
 Estates of from 10 to 25,000 acres, and an infinite number of freeholders; yeomanry estates of all inferior sizes: much copyhold, but the lords upon some customary manors have enfranchised the copyholders upon receiving an equivalent in money.  
 3. *Buildings.*  
 Some good new mansions; above eighty of these named in old maps become farm houses. Farm houses generally in villages. Excellent new ones on the Marquess of Stafford's estates. (fig. 764.)

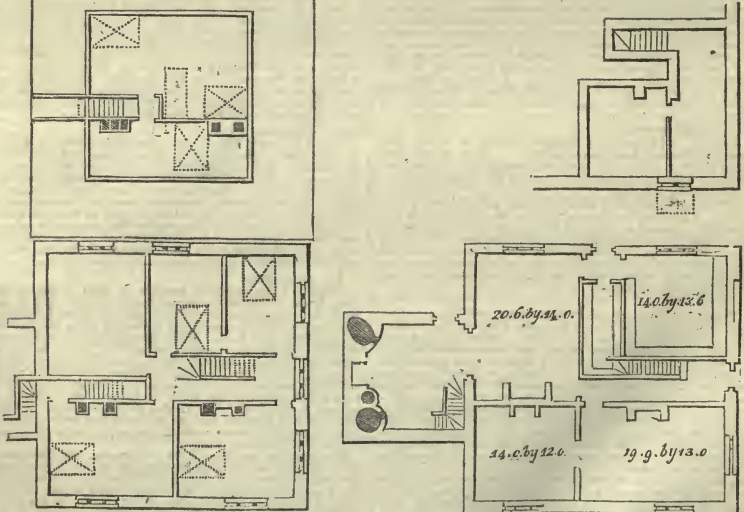

Comfortable cottages with gardens much wanted. Some judicious observations by Plymley: prescribes no particular forms, but suggests the impropriety of making them, or indeed any other object, bear an outward appearance, intended to contradict their inward use; all castellated or gothicised cottages, all churchlike barns, or fortilike pigstyes, he conceives to be objectionable. They are intended to deceive, and they

tell you that they are intended to deceive. It is not pleasant to encourage any thing like deceit, but in these instances imposition effected is rarely gained; if it amounts only to imposition attempted; or, could the deceit succeed, it would only present a prospect with fewer proprieties about it than there really are. Almost every species of country building has a good effect, if properly placed and neatly executed; and what are

the least ornamental, or indeed the most disgusting, of their appendages, cease to shock, when supported by the relative situation they stand in, showing their necessity and their use. A dunghill in a farm-yard creates no disagreeable idea; but connected with a gothic gateway, or embattled tower, it is bad. Cattle protected by the side of a barn, form a picturesque group; but sheltering under a Grecian portico—the impropriety is glaring. Linen hanging to dry on the hedge of a cottage garden, may be passed without displeasure; but the clothes of men, women, and children, surrounding the cell of an anchorite, or the oratory of a monk, have their natural unseemliness increased by the contrast. On the other hand, a fine-dressed lawn with miserable cottages may be compared to the laced clothes and dirty linen some foreigners were formerly accused of wearing. The whole of a gentleman's estate should be his pleasure-ground; the village should be one object in the scene; not shut out from it. There may be a little more polish about the mansion, but it should not be an unnatural contrast to the surrounding objects. The face of no country is bad, but as it is disfigured by artificial means; and the cheapest and best improvement is, merely to remove what offends, and to take care that the buildings or fences that are wanted are neat and appropriate, exhibiting distinctly their real intention. Plymley is a friend to single cottages, because two families under one roof may have more causes of contention arise between them. On the other hand, in illness, poor people have frequently the merit of forgetting their differences; and then the assistance they are inclined to give each other, is made more easy by nearness of situation. It is possible, however, where two, or even three houses are joined together, to contrive the gardens in such a manner, that there may be a little interference; and sometimes three neighboring families may do better together than two.

**4. Occupation.**  
On the borders of Wales the farms are small, many not exceeding twenty acres; on the east side of the county from one to 500 acres; farmers in general very industrious; work along with their servants; wives brew, bake, dairy, and at spare hours spin and get up a piece of linen cloth for sale every year. Leases for lives formerly very common. Bishton, of Kilsall, has taken great pains to prepare printed leases, which answer very well; the term he recommends is seven, fourteen, or twenty-one years; by being printed the farmer can read them at his leisure.

**5. Implements.**  
Plough with two wheels, drawn by four or five horses, or six or eight oxen in the strong lands, and two horses with a boy to drive in the turnip soils. Various improved implements and threshing machines; some excellent mills on Lord Stafford's estates, driven by steam.

**6. Enclosing.**  
Much practised and still going on. Plashing hedges is usually very ill done in Shropshire; it is a business which requires great nicety and judgment, and has the most ignorant operators to perform it in general; who, in the first place, cut downwards through mere idleness, instead of upwards, and so expose the heart of the plant to the weather. Many miles of hedges lately planted on the Stafford estates.

**7. Arable Land.**  
Following very badly done on the strong lands. Common crops of the county wheat, barley, oats, pease, and turnips. Pease found not to boll well unless grown on a sharp gravel or sand; those grown on clay given to pigs and horses. Some hemp and hops cultivated.

**8. Grass.**  
Some natural meadows on the Severn and other rivers; not much attention paid to them. Artificial herbage and grasses grown on the turnip soils.

**9. Gardens and Orchards.**  
Many farmers have small orchards, from whence they make a little cider for home consumption, and on the confines of Herefordshire and Worcestershire the orchards are larger, and cider is made for sale.

**10. Woods and Plantations.**  
A good deal of hedge-row timber, and some fine oak woods; also numerous young plantations. Narrow-leaved elm reckoned an excellent hedge-row tree, but the broad-leaved better timber, and less difficult as to soil and situation. In this county few persons will bury their relations in any but the best oak timber, which contributes much to its scarcity.

**11. Improvements.**  
Marl used, and some irrigation. A good deal of draining done with brick, stone, and faggot wood. Some bogs drained in Elkington's manner. On the Lilleshall estate of Lord Stafford, (fig. 785.) in 1816 and 1817, there has been executed about 17,000 yards of embankment; 27,000 yards of water-course

785



deepened and scoured; 46,000 yards of main ditches made or deepened; 315,000 yards of fence-ditches deepened, scoured, and straightened; 49,000 yards of old fences stocked; 50,000 yards of new quick fences made; 21,000 yards of turf draining; and 462,000 yards of under-ground draining, laid with tiles and filled with stones. Besides the erection of many new farmhouses of the most commodious plans and substantial execution. But to have an adequate idea of these and other improvements effect-

ed by this munificent and patriotic nobleman, it is necessary to peruse the very interesting work of Loch already referred to. On the Wildmoor estate of Lord Stafford (fig. 786.) excellent roads have been formed, so that several parts before inaccessible in winter and during wet weather, may now be approached at all times with ease. The effect, as Loch observes, has thus been to add so many acres to the estate. But the most considerable work executed upon these estates, is the drainage of

the extensive district alluded to, called the Wildmoors. The extent and nature of this improvement is such as to deserve a particular and detailed description. Some adjoining properties have benefited by this work, and contributed to the expense of it, which was done under the authority of an act of parliament. But as almost the whole of the land belongs

to the Marquess of Stafford, and the expense having been chiefly borne by him, the direction of its progress, and its preservation hereafter, is entirely vested in a surveyor chosen by his Lordship. These moors consisted of an extensive tract, amounting, with the land similarly circumstanced, to near twelve hundred acres. The soil is composed of a fine black peat, incumbent

786



on a bed of red sand, full of water. They are bounded chiefly by the upland part of these estates, and surround the parish of Kynnersley, which also belongs to it, and which is composed of some of the finest turnip and barley soil in the kingdom. They had evidently formed the bottom of an extensive lake. The different brooks from the surrounding country held their course through them. These brooks are known in the country by the name of *Strines*, being distinguished from each other by the name of the places from which, or past which, they flow. Their course to the Tearn (which river drains the whole of this country into the Severn) was devious and crooked in the extreme, injuring to a great extent the land through which they ran.

A great proportion of these moors was occupied by the tenants of the adjoining farms, who turned their stock in upon them for a portion of the summer season only. During the rest of the year it was impossible to use them. They afforded but a small quantity of food, and were in most places so wet, that it was at all times difficult to walk over them, it being necessary to select the hardest places to step on. They were covered with water after almost every severe rain, owing to which the inhabitants of the neighborhood were subject to frequent attacks of ague. The adjoining lands, besides, to an extent exceeding six hundred acres, were kept in nearly a state of nature, owing to there being no level by which they could be drained, while this extensive district continued subject to such inundations.

The difficulty which occurred, in draining this tract of land, arose from the want of level, and from the river Tearn being ponded so high by the mill pools, as to throw the water back to a great distance upon the land. The plan for draining this extensive district was extremely well conceived, and judiciously laid out, in the double view of securing this object, and of interfering as little as possible with private property and the existing establishments situated on the Tearn. It was suggested by John Bishton, Esq. the first commissioner under

the Act. The great object was to gain as much additional level as would create a run throughout the whole extent of the moorlands. This was to be obtained by beginning the cut which was to carry off the water a considerable way lower down the Tearn than the water had hitherto been discharged into that river, and a good deal below the mill-pool at Long, which occasioned this pondage. The original courses of the strines were straightened and widened, but they were still made to convey the water from the uplands, and to discharge them into the Tearn in their original direction. To prevent them overflowing the adjoining lands, and to cut off the effects of the back pondage of the Tearn on the upper moors, these brooks were embanked for the whole length of their course through the Wildmoors. These are technically called *argue banks*. At the back of these banks deep ditches were carried, but in a more direct line than the course of the strines. Into these ditches the drainage of the moor-lands is emptied. The level which was thus brought from the river Tearn, from below Long Mill, was carried in a tunnel under the Shrewsbury canal, and was conducted below the several strines in siphon culverts, and thus communicated with the ditches described, as having been made behind the banks which confined the waters of these brooks.

In some instances, it has been necessary to construct one set of culverts over another, in order that the waters coming from the uplands may be kept in the several brooks through which they had constantly flowed, and that this water flowing from the uplands might not fall into the back drains; it being again explained, that the water flowing from the higher grounds is still confined to the original strines or brooks on an upper level; the drainage water alone of the moor-lands being thrown into the back drains. Thus has a great additional level been obtained, and the whole of this district is now entirely relieved of water, and such a thing as a flood has not been known for years. This district is, in some instances, so flat, that the old course of the Preston strine, which formerly

787

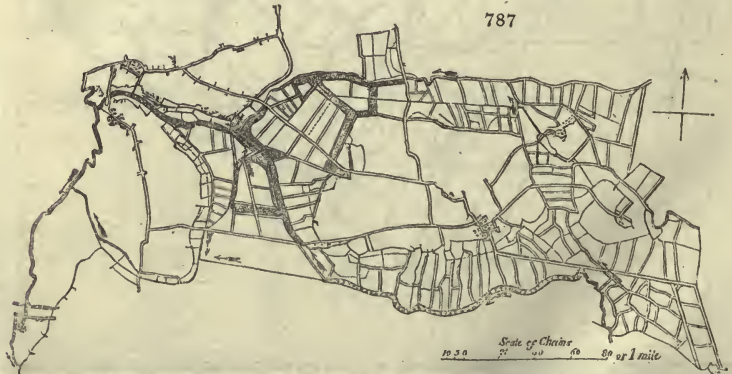

conducted the water of that brook in one direction, has, with little difficulty, been made a part of the drainage, and to carry the drainage water in exactly the contrary direction, a new channel having been cut for the strine. Taking advantage of

this drainage, main ditches, upon a regular system, have been carried into all the neighboring parts of the estate, thereby enabling the landlord and the tenant to execute various other improvements.

This district has been subsequently divided into *regular enclosures*, by great ditches, which fall into the main drains; and, wherever it has been possible, these ditches have been made to serve this purpose, as well as that of a fence to the great roads which have been constructed across these moors. In one instance, one of these roads has been carried in a straight line for about two miles. On each side of this road trees have been planted, at regular distances, which will soon form one of the finest avenues in England. These moors have besides been all regularly under-drained by turf drains, which stand remarkably well. In the different ditches are placed flood-gates, to pound back the water during the summer, preserving the meadows in a state of perpetual verdure. The water is let off at least once in every fourteen days, and being drawn off with as much velocity as possible, it scours and keeps clear both the ditches and the underground drains; — the mouths of these latter are all defended with tiles. The moorlands have been greatly improved by very heavy and repeated rollings and top-dressings; and their value as let to a farmer, in many instances, is fully doubled. This improvement has cost a very large sum of money; which was encresced beyond what was necessary, owing to the inefficiency of a late surveyor belonging to the commission, which is not yet closed. The drainage, however, has lately been put under a surveyor (Lewis), approved of by Lord Stafford in terms of the Act, and the expence is diminished, and the whole put in better order. A very rapid improvement has taken place on these lands. In place of being the very worst part of the estate, they are rapidly becoming equal to the best and finest meadows on it. In order to collect them from the blasts which come round the Wrekin, from the West mountains, they have been intersected with various plantations. A plan of the Wildmoors previous to, (fig. 786,) and another subsequent to this improvement, (fig. 787.) will serve to give an

accurate notion of what has been done. The whole being well worthy the examination and inspection of an intelligent agriculturist and improver. (Loch, p. 226.)

12. *Live Stock.*

Cattle of mixed breeds; some dairying, chiefly for butter to the manufacturing towns; some cheese, but not very good. Calves raised as stock, and sometimes suckled for veal. Sheep in breeding flocks of various kinds. Stock in general neglected as to improvement; all sorts of crosses permitted, so that the original breeds of sheep and hogs are now lost. Pork and bacon are much used among the poorer people, when they can procure them; therefore the sort which is to be fed with the least trouble is to be preferred. A mixture of the Shropshire and Chinese has, in this respect, been found to answer for bacon, and a cross of the wild breed for pork.

*Geese*, reared on the commons, and sold to farmers, who fatten them on their stubbles.

*Turkeys*, reared in large quantities by some farmers, and sold to hielers, who drive them to Birmingham and other large towns. Markets in general well supplied with fowls. It is to be lamented that they are generally carried alive to market. Death is no misfortune to an animal that has no previous apprehension of it. But poultry, carried in bags or baskets to market, have several hours of previous suffering, and the burthen and trouble of carrying them thither seem much increased thereby.

13. *Political Economy.*

Roads generally bad; various canals; trade of Shrewsbury, flannel and Welsh wels, used for clothing for the slaves in the West Indies and South America. Manufactures in the county numerous; Iron, pottery, porcelain, glass, dying cloth, woollens, flannels, linen, gloves, &c. An agricultural society at Drayton.

7011. STAFFORDSHIRE. 780,800 acres of hill and dale, some parts rugged and others smooth, but on the whole more a mining and manufacturing than an agricultural county. The Marquess of Stafford, Lord Anson, and Marquess of Anglesea, are the chief improvers. Excellent markets for produce within the county in consequence of the numerous manufacturing towns and villages. (Pitt's Report, 1808. *Marshal's Review*, 1813. *Loch's Improvements*, 1819.)

1. *Geographical State and Circumstances.*

*Climate.* Air sharp and cold, and inclining to wet; annual rains thirty-six inches; those of London twenty or twenty-one inches; of Winchester, in Essex, nineteen inches, and a quarter; Lancashire forty-two; of Ireland forty-two to fifty. Annual rain on the west side of the kingdom double that on the east side.

*Surface.* In the north side of the county hills arise, forming the commencement of a ridge, rising gradually higher and higher into Scotland, under different names; here called Moorlands, then Penk, then Blackstone Edge, then Craven, then Stanmore; and then, parting into two horns, called Cheviots.

*Soil.* Very various; about one-third of the county strong loam or clay; one-third mixed soils of almost all sorts, and the remainder light, calcareous or aluvial.

*Minerals.* Valuable and extensive; 50,000 acres or upwards of coal. Iron ore and lime of unknown extent.

2. *Property.*

Large estates 10,000*l.* a year, and many of all sizes, from that amount down to 40*l.* a year. Attornies generally the managers, but some excellent examples of gentlemen of from 500*l.* to 5000*l.* a year managing their estates in person; residing on them, and cultivating a part, and giving every encouragement to their tenants.

3. *Buildings.*

Some noble mansions, as Trentham, Beaudesart, Ingestre, &c. Excellent farm-houses constructed on some estates, as Trentham, Lord Stafford's, but the majority, as in other counties, bad, and badly situated. A farm yard has been constructed at the family seat of the Ansons, for a demesne farm of 2000 acres. It was built by S. Wyatt, of London, and consists of the following several house and out buildings; a range of building along one side contains a brewhouse upon a large scale, a water corn-mill for the family and farm use, and in which corn is ground for the neighboring poor gratis, and a malt-house: the opposite side and end are occupied by stalls for feeding cattle, store-rooms, stables, and other appendages; and in the middle of the yard is a very complete hogery, built of large stones set edgewise, and covered with slate, with a boiler for heating hog-food, a cold bath supplied by the mill stream, for giving an occasional swill to the young pigs. In this building a number of hogs are fatted on dairy refuse, boiled roots or vegetables, pulse, ground barley or bran, supplied by the mill near at hand. At some distance above is the stack-yard and barns, where a powerful threshing machine is worked by the same stream that afterwards supplies the garden, and turns the corn mill in the farm-yard.

4. *Occupation.*

Farms of all sizes, from twenty-five to 500 acres; many consolidated since 1793. Some very good cottages with gardens, and containing comfortable and commodious accommodation for agricultural or manufacturing operatives. A specimen of one is given (fig. 788.), which contains a living room (a), working or lodging room (b), pantry, dairy, cellar, &c. (c), cow-house (d), with a water closet, and three bedrooms over. Leases generally granted for twenty-one years. Little made by farming unless with a combination of all, or most of the following circumstances: first, an easy rent; second, a pretty good and extensive farm; third, economy and industry; and fourth, length of time. In the present system of farming, at a moderate rent, the writer of this knows from experience, that it requires not only the most diligent industry, but also the most prudent economy, to keep the balance on the right side. To which Marshal adds, "I have rarely found a farmer making a fortune by his profession alone, unless on fresh land, on virgin marsh, old grazing ground, ancient sheep walk, or a small acre and extensive farm; I mean, any way resembling that which, with the same ability and industry, and with a small share of the outset capital, he would have been making by trade, manufacture, or commerce."

5. *Implement.*

Very various; double furrow ploughs drawn by four horses, a good deal in use in the light lands. Excellent threshing ma-

chine, and various new implements introducing by proprietors, and especially by the Marquess of Stafford.

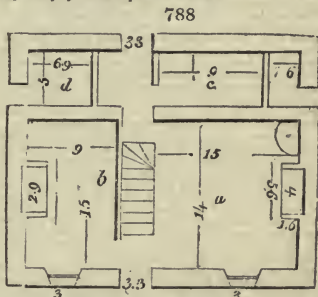

6. *Arable Land.*

Most annual field crops cultivated, including hemp and flax.

7. *Grass.*

Meadow on the rivers and brooks, and artificial grasses sown; feeding in general preferred to dairying.

8. *Gardens and Orchards.*

Common to many farm-houses; but few or no sale orchards, and scarcely any fruit crushed for liquor.

9. *Timber and Woodlands.*

Best timbered estate Blithfield Park, Lord Bagot; the park contains many hundred trees of extraordinary bulk, containing from 200 to 400 feet of timber each; much of it is mentioned by Dr. Plot as full grown in 1686. Chillington and Beaudesart also remarkably well timbered. The remains of Needwood forest, chiefly remarkable for its beautiful hollies. On the whole the county abundantly wooded. Sneyd's coppices cut once in six years to make crates and large hamper for the potteries.

10. *Improvements.*

Irrigation and draining practised, the former only to a moderate extent. Jessop, the engineer, suggests that nine parts in ten of the waters of the kingdom at present run away in waste, a great part of which might be usefully employed; nay, further (putting expence out of the question), that every stream in the kingdom may be made to run equally through the whole year. This position, however extraordinary, is easily demonstrable; for if, upon any given stream, one or more reservoirs be made, capable of containing its flood water, and through the dam or dams be laid a pipe or pipes, whose apertures will just discharge the average produce, the business is done; and though there may be some probability of this business being ever brought to great a nicety, yet, from hence some idea may be formed of the prodigious extent to which improvements by water may be carried.

*Great and radical improvements* have been effected on the Trentham estates. The first object was the laying the lands together, in farms of considerable extent, varying in size according to the nature of the soil, and other circumstances. In effecting these necessary changes, wherever the old tenant was removed, which was done as seldom as possible, he was, unless he took a farm elsewhere, accommodated with his house and his best grass crofts for his life, at a low and inadequate rent; and in every case where it was possible to treat with the person beneficially interested in the lease, and whose continuance in the farm was incompatible with the new arrangement of the land, his interest was purchased either for an annuity, or a

sum of money, to enable him to look out for, and to stock a new farm. The size of the farm being thus enlarged, it was necessary to enlarge the fences, the enclosures, and to lay several closes into one, and, where possible, to give them a more regular and uniform shape. This arrangement enabled the landlord to get rid of the long useless lanes, by which a considerable addition to the number of arable acres was acquired.

In order to give each tenant every advantage in draining his farm, the great lines of ditches were executed by the landlord, and wherever it was possible, these were the boundaries of the farms. In this whole drains on the estate were conducted according to one uniform plan, by which the system of drainage was rendered much more complete, and the interests of the whole, and not that of any individual tenant, were consulted, nor was any one allowed to interfere with the interests of his neighbor. Such a perfect system will have the effect of rendering the condition of these estates more complete in this respect than that of any other in England. Attention has also been paid, in the execution of these works, to make the water available for the construction of water-meadows, and for impelling the threshing machines of the respective farms.

In consequence of the complete state of ruin in which the farm buildings on these estates were found, it was necessary to incur a serious expence in constructing new ones. In this way it has been necessary to erect thirty-seven new, and to repair throughout eight other extensive sets of farm offices, besides the smaller repairs which such estates necessarily require. They have been executed in the most substantial manner. They are built of the best possible brick-work, covered with tiles or slates; and their cost, including the expence of those thoroughly repaired, may, on an average, be stated at from 1500*l.* to 1600*l.* each.

We have already given examples of these buildings (2765. and 2765.), which are remarkably complete in design, and substantial in execution, and several of them are furnished with threshing machines, driven by water or steam, a thing rare in England, excepting in Northumberland. It is believed, Loch observes, that they unite as many advantages with as few faults, as any buildings of the sort, and that they will supply useful hints to others.

It had been at one period the custom to permit *huts* to be erected in all parts of the estate. These huts amounted in number to many hundreds; they were inhabited by the poorest, and, in many instances, by a profligate population. They were not regularly entered in the rental book, but had a nominal payment fixed upon them, which they paid annually at the court leet. These cottages were built on the sides of the roads, and upon the lord's waste, which was gradually absorbed by the encroachments which the occupiers of these huts made from time to time, by enclosing that which lay next to them. They gradually fell into the hands of a body of middlemen, who underlet them at an extravagant rate to the actual occupiers. In this manner the poor people were oppressed, and the landlord was in danger of losing his property.

To remedy the evils arising out of this system, the cottagers were made immediate tenants to the landlord, and their rents made payable at the half-yearly audits; an arrangement perfectly satisfactory to them, as they were no longer exposed to the vexations of an intermediate possessor, and, in many instances, their rents to the landlord were less than they had been accustomed to pay to those from whom they had hitherto held their houses. Since they have been placed in this situation, greater attention has been necessarily paid to their conduct and character, as well as to their wants. As they know that their good conduct will now be noticed by, and meet with the approbation of their landlord, a considerable improvement in their habits has taken place. There can be no doubt but that these important and necessary arrangements are far from being agreeable to those who suffered from them. In altering such a system, not only was the direct interest of the existing middlemen affected, but also the expectant interests and influence of many who contemplated the chance of one day benefiting from their favor. These were not few, and it did not always happen that the person who expressed his dissatisfaction loudest, was the one most likely to succeed in his wishes: and, in proportion as this object was near its completion, was the vexation and discontent of those who were disappointed. To the larger farms some of these cottages have been added, to enable the occupier to put into them married farm servants, who have thus a great inducement to behave honestly and industriously, and to attend with good will and zeal to the interest and the business of their master. It is by giving such inducements as this, and by making them feel an interest in acting right, that this most invaluable class of laborers can alone be maintained and supported.

What has been done by the proprietors, has been well seconded by the exertions of his tenants. A more respectable and enterprising body of men do not exist; and, while they are in a better situation of life than a great body of this class, they have not allowed themselves to forget, that it is by a constant attention to their business, by their keeping in the line of life to which they belong, and never attempting to commit the management of their affairs to bailiffs, that they have gone on steadily improving and bettering their condition. In the knowledge of stock, in their capital and skill in the management of their grass land, and in the cultivation of and in cleaning their lighter soils, they are surpassed by no farmers in the kingdom. The rotation they follow is the Norfolk husbandry; and in the cleanness of their crops, and the excellence of their drill turnips, they cannot be surpassed. The breadth of turnip annually sown is very great, and the rapidity with which they have adopted the drill system of husbandry, is as creditable to them as the satisfactory manner in which they have proceeded.

Except ploughing with too many horses, and not being sufficiently active in getting in their harvest, they have fewer practices to abandon, and there are fewer things which they have to adopt from any other of the well cultivated districts of the island, than is generally the case. Every means has been used to explain to them the advantages of ploughing with fewer horses, and there is every reason to expect that their good sense will soon see the necessity of their adopting these, as many of them have already adopted this system. The fault, therefore, the difficulty consists in being able to persuade the ploughmen to adopt it, as the labor of holding the plough is more severe: it is impossible for one or two individuals to contend successfully against the feelings of a country; but when undertaken

by so numerous and wealthy a tenantry, supported by the influence of the landlord, these feelings must speedily give way.

This mode of ploughing has made rapid progress at Trentham. The reason of which is, that it is more generally admitted, that this system is calculated to suit the stiff, better than the lighter soils, inasmuch, as two ploughs, drawn by two horses abreast, do much more work than a double plough, drawn by four horses, can do in such soil: the superiority of the work, also, is very conspicuous. On the other hand it is argued, and with some apparent force, that the double plough, drawn by four horses, and guided by one man, can do as much work as two ploughs drawn by two horses each, and guided by two men. In this way the labor of one man is saved. It must be admitted that the argument would be in favor of the double plough, were it not that the work it performs is neither so neat, so perfect, nor can it plough so deep as is done by the two-horse system. It is remarkable that this mode of ploughing with two horses should be confined to the eastern parts of England, from which it was adopted, at no very distant period, into Scotland, where the ploughing with a number of horses yoked along with oxen existed to an extent never practised in any part of this country.

In order to encourage these men to make this change, an annual ploughing-match has been instituted, at which prizes are distributed to the best ploughmen. The effect this has already had is very considerable; and in the year 1814, no fewer than fifty ploughs started for the premiums. The progress of such a system must be slow; as it cannot be expected that the tenants should at once lay aside all their old implements, and purchase new. The difficulty of procuring good ploughs operated much against the adoption of this mode of ploughing. In removing this inconvenience, there has been established, both in Shropshire and in Staffordshire, a manufactory for the construction of the more improved implements; modern husbandry is now, and it is strongly recommended to the persons who have been thus established, that they should take their apprentices entirely from the lads of the country.

It is in the management of their stiff lands, that the tenants are most defective. Of late, however, they have made so great exertions in draining their lands, that it is hoped they are beginning to adopt a better system. The defect of their management consists in their ploughing very shallow; the effect of which is, that the depth of soil is not sufficient to protect the roots of the plant from being chilled with the cold and wet (which is upheld by the impervious nature of the subsoil), when the ground is wet, and exposes it to the too rapid action of the drought when the weather is dry. To plough deeper is, therefore, the first, the most simple, and the most important improvement which can be adopted in these soils.

They also, until lately, hurt these cold lands by making use of a large quantity of a bad sort of red clay marl, which they dug out of every field. The effect produced was, to increase the tenacity of the soil, and to render it still less fit for the purposes of agriculture. Of this fact, all the intelligent part of the tenants are themselves convinced, though some of those who are still wedded to their old customs, lament the regulation which prohibits them from using this article. On those farms where the inclosures have been entirely renewed, and where, in consequence, a portion of several of the ancient inclosures have been thrown into one close, the bad effects of the system of marling is perceived in a remarkable degree, and a distinct line in the appearance of the crop, points out with precision the land which had been formerly so treated, from that which had not. The consequence of this prohibition has been, that the tenants have applied themselves much more to the use of lime as a stimulant, which has repaid them, as might have been expected. It has also put a stop to the rapid deterioration of which was occasioned by the alignment of the pits, which everywhere disfigure and destroy a considerable portion of the farms of this district.

To level down these marl-pits, and to render them again fit for the purposes of husbandry, has been an object of great attention. In this way there was applied the labor of a great proportion of the parishioners, to whom, from time to time, employment had been afforded, in those years when the circumstances of the country rendered such an exertion of the landlord's charity necessary. This was most particularly the case in 1817; in which year a vast body of men was employed on each of the Marquess's estates.

In another particular, the management of the stiff soils might be considerably amended; which is, in the mode of working the fallows, which are left too generally to grow full of weeds, in place of being cleaned as they ought to be. The muck, also, is laid on at an improper season of the year, by which its good effects rather go to encourage the growth of the weeds, than to improve the crop. At Trentham the strong soils are of a far superior quality, fit in every respect for the most improved system of wheat and bean husbandry. But the lands were so much subdivided, and the capital of a large proportion of the tenants, until lately, was so inadequate to the right cultivation of their land, that no improvement could take place or be expected, and this estate remained stationary, amidst the general progress which was so conspicuous in the other parts of the county. These defects have been remedied in both instances; and the introduction of some skillful farmers from Shropshire and Cheshire, at Trentham, has given rise to that spirit of enterprise which at present characterises the tenants of these estates, and which must prove so beneficial to the country, by the additional surplus produce which will be brought to market.

The rotation which they followed, on both estates of the stiff soils, was, — fallow, wheat, clover, &c. That is now altered, by clover being substituted after the wheat; and an attempt has been made to induce them to try a six-shift course of husbandry, by introducing beans into their rotation. Little progress, however, has, as yet, been made in this experiment. To this they have considerable objection, which arises from the defective mode of cultivating their bean-crop. In the first place, they are unwilling to sow them in drills. They are, besides, loath to plant them, and allow them to stand later in the year than they ought to do. The consequence is, that their crop is often damaged, and the nutritious matter of the bean-straw is entirely lost. They cannot be persuaded, therefore, that it forms an excellent and nourishing food for horses and cattle; and the complaint that they make of its being un-

exhausting crop is quite correct, in consequence of their permitting it to stand so long upon the ground.

One improvement the tenants have paid much attention to, and a more valuable one they could not adopt, which is the construction of water-meadows. They have lost no opportunity in making use of whatever water they could obtain for this purpose. They were allowed the rough materials to construct the flood-gates, and the example was shown them as to what could be done in this respect to a very great extent at Trentham. The value of this improvement is well known to every experienced agriculturist in England, and no opportunity should be lost in taking advantage of every circumstance to promote its adoption. There has been lately finished, a new water-meadow on the home farm at Trentham, at the expense of about twenty pounds an acre, which will now let for near four pounds an acre, beside the advantage derived to the adjoining upland. This meadow was not worth ten shillings an acre, previous to such an improvement. It consists of a small deep dingle, with steep banks, in which a copious spring rises near the top; the upper part being formed into a fish pool. From this head the water is conducted on the different levels on each side, with the proper catch-water drains carrying the water round the various knolls. The whole being adorned by some fine trees, it forms for its extent a very perfect union of useful and ornamental farming. It shows how much may be made of such a piece of land, incapable of any other sort of useful occupation.

Much money, however, in this neighborhood has been thrown away by watering land which has not been previously thoroughly drained; this latter improvement is the foundation of all others. Another mistake has also been fallen into, by attempting to convert into water-meadows peat soils, without first bringing them to a proper state of consistency by means of repeated heavy rollings and top-dressings. A proportion of ten acres of water-meadow to every hundred acres of pasture or arable land, adds at least two shillings and six-pence an acre to the value of every acre of such a farm, in addition to a fair rent being put upon the meadow.

The attention and influence of Lord Stafford has been used in whatever way it could be employed beneficially in extending the comfort or advancing the good behaviour of his cottagers; a conduct so characteristic of the great and wealthy proprietors of these kingdoms, that it must ever distinguish them in the history of human benevolence.

Schools, wherever they have been necessary, have been encouraged, either aiding them by subscription, or by granting the accommodation of school-houses. Two Banks for Savings, one at Lilleshall and another at Trentham, of which Lord Stafford is the treasurer, have been established, and the whole details are conducted by his managers, assisted by the parochial clergy, and the principal tenants, and their success among the agricultural laborers has been very gratifying.

The charities of this family are worthy of an English nobleman; and during the residence of the Marquess and Marchioness at Trentham, there is distributed daily, to every poor object, who is travelling along the road, and who applies for the same, a portion of good wholesome bread, in quantity about fourteen ounces to each full-grown man, and less in proportion to women and children, with a pint of good table-beer. The number of people who received this donation in 1819, amounted to 9504 men, 3276 women, and 1789 children, consuming 1590 loaves, and 1705 gallons of beer. From this charity are excepted all soldiers and sailors receiving the King's pay, all persons residing within the parish of Trentham, or in its immediate vicinity. Other distributions take place on particular occasions; for example, to those who reside in the parish, annually on St. Thomas's day, there is a distribution of a certain quantity of beer to the poor. During 1819, there were 12,785 quarts of rich soup, above 100 quarts of milk, distributed within the parish, besides 14,134 quarts of milk given away under the head of allowances. Such facts are strongly illustrative of the beneficial effects derived to the

poor, from the residence of the great families of England, on their respective estates.

The foregoing statement would have been given with some hesitation, had not the facts been of a nature rather to exhibit and illustrate the character and extent of the charities distributed by the great families of England in general, than as being at all peculiar to the instance to which the details belong. And these facts may help to explain to foreigners the nature of the connection which exists between the richer and poorer classes in this country.

The town of Linc-End, one of those which compose the Staffordshire Potteries, is partly situated on, and is partly contiguous to the east end of the Trentham estate. The inhabitants being ill supplied with water, carried in barrels, they petitioned to be provided with this necessary article, which request has been complied with; and this town, after a very considerable outlay, now enjoys a regular supply of water, conveyed in iron pipes.

The character of the numerous cottagers upon the estates, is also an object of great solicitude, and without any interference with the manner in which a man may choose to occupy himself, their regular and decent behavior is made the subject of care and attention; and the steward has strict directions to watch carefully over them, and where possible to promote their improvement. Wherever a potatoe garden can be added to their cottages, that accommodation is afforded them. In the vicinity of Litchfield, the cottages are of the best sort, and with their gardens kept in the nicest order. To almost every one of them is attached land for the maintenance of one or two cows. It is a circumstance worthy of remark, that of all the laborers who possess a cow, none receive relief from the poor's rate, except one widow at Trentham, who has a large family, and even in this instance, the relief she receives is in a less ratio, than any person laboring under similar difficulties.

11. Live Stock.

Cattle generally of the long horned breed. The Staffordshire cow is generally considered a tolerable milker, as well as feeder.

Sheep. Three sorts considered native breeds: the grey faced hornless or Camnock heath sheep, with fine wool; the black faced horned, with fine wool; and the white faced hornless, with long wool.

Swine. A cross between the slouched-eared and dwarf breeds; require little attention or feeding, and easily get fat on the refuse of the dairy or barn. Pitt, the reporter, had a very fine sow, which littered ten at the first litter.

Bees. Wild in the sandy lands. A good many bees kept; Thorsley's plan tried, but bees are found to succeed best in straw hives thatched in autumn. "Those which have not raised a sufficiency of food for winter, it is doubtless humanity to destroy, as sudden suffocation is better than a prolonged but sudden starvation."

12. Political Economy.

Roads now generally good; numerous canals; several private rail roads. Manufactures, iron, hardware, nails, glass, toys, japanned goods, potters ware, cotton cloth, silk fabrics, leather, woollen, linen, and many others. Manufactures sometimes carried on in the country in straggling groups of houses, but for the most part in towns. Many thousands both of men and women employed in making nails. An agricultural society at Newcastle and another at Litchfield.

Experimental farming. "It would be a wholesome plan for the Board to commence farming upon their own ideas, particularly in counties where the modes of agriculture seem improper; for instance, Lancashire, Westmoreland, Cumberland, Northumberland, &c.; by which ocular demonstration their plan might be imitated; for hearing or reading of any particular practice will not do for farmers in general." Such is the reporter's opinion, in ours a more erroneous one.

7012. WARWICKSHIRE. A surface of nearly 600,000 acres, mostly flat, but generally rich in soil and beautiful in appearance. It is chiefly a corn county, and produces excellent wheat, but also many fat cattle, and formerly much cheese. There are no distinguished agriculturists in the county; but it has produced more good to agriculture than many others, by giving birth to Elkington, who gave rise to much discussion on draining. (*Wedge's Report*, 1794. *Murray's Report*, 1808. *Marshall's Review*, 1813.)

1. Geographical State and Circumstances.

Climate, mild and healthy. S.W. the prevailing winds; effects of an easterly variation felt till the middle of May, and vegetation checked; not however by excess of damp or frost.

Soil, chiefly clay or sand, marl, and limestone. The portion of sandy or moorish soil very small.

Minerals, coal, limestone, freestone, iron, blue flagstone, marl, blue clay, and soapy clay, which the late Earl of Warwick attempted to prepare for sale as a soap.

2. Property.

Largest estate Stone-Leigh, Rev. Thomas Leigh, 25,000 acres; but a great variety of extent, and some curious and absurd tenures.

3. Buildings.

Warwick Castle and Ragley first rate edifices. Old farm-houses built of mud and timber, and frequently at the extremity of the farms. The Duke of Buccleugh, at Dunchurch, has constructed some good farmhouses. Cottages miserable hells.

4. Occupation.

Farms from 80 to 500 acres; 150 the average size; on the increase. Farmers in general exceedingly shy and jealous; one considered as at the head of his profession, told Murray "he did not see any advantage the county of Warwick would derive from such a survey; that it must do a great deal of hurt instead of good; and that such being his opinion, he declined giving any information on the different heads of queries put to him. Lands generally held at will, but very low rents. Cheap farms, in general, are a drawback on industry and improvements: farmers that have cheap farms may farm, well, but those that have dear farms must farm well, or their career will soon terminate.

5. Implements.

Ploughs the double and single Rotheram with wheels, the

double drawn by five or six horses in a line, the single plough by three and four, or five, horses in a line, and in both cases with a driver. Small's plough with two horses abreast, and no driver, the reporter remarks, would make better work and do more of it. Some winnowing and threshing machines in use by proprietors.

6. Tillage.

Large crooked ridges gathered very high with a small one between; go only one yoking per day throughout the year. Following general, and then two white crops.

7. Grass.

235,000 acres in meadows and pastures, and 60,000 in artificial herbage. Formerly dairying common, and Warwickshire cheeses produced in abundance; but now breeding is fast assuming its place. Old pastures often overrun with ant-hills and rabbits. Murray very prophetically observes, that if peace were to take place, grass lands would be asfer for the farmer than corn lands. Dairying and feeding both in practice.

8. Gardens and Orchards.

The gardens of the Marquess of Hertford noted for their pine apples; few sale orchards of any extent.

9. Woods and Plantations.

Oak and elm every where abounds; and the Leigh estate the best wooded, but every where abundance of timber.

10. Improvements.

Much draining done in the northern part of the county, but it is rather singular that the names of Fazley, Elkington, or their farms are not once mentioned in Murray's report. Joseph Elkington lived at Frinchtrop, in Stretton on Dunsmoor, s. w. of Coventry, and afterwards in Birmingham. He died in 1806. He was a mere empiric practitioner, and knew nothing of geology, the only foundation for draining on scientific principles; less even than some of his contemporaries, as Farey has ably shown in the Derbyshire report. Irrigation practised in a few places on a small scale.

11. *Live Stock.*

No particular breed of cattle, but as feeding is the prevailing practice, farmers buy in whatever breed they think will pay them best.

Sheep a good deal attended to; the large polled sheep, or ancient Warwickshire, now generally mixed with other breeds. The first cross of a Leicestershire ram and Warwickshire ewe produces the best sheep for the butcher.

Horses, the heavy black Leicestershire breed; a good many bred, both of cart, coach, riding, and hunting horses.

7013. LEICESTERSHIRE. 529,240 acres of gently varied surface and fertile soil; distinguished by its pastures, and for the progress which has been made in the improvement of cattle and sheep. It is the country of Bakewell, whose name will ever stand 1794. *Pitt's Report*, 1809. *Marshal's Review*, 1813.

1. *Geographical State and Circumstances.*

Climate mild and temperate; no mountains or bogs to produce a cold or moist atmosphere. Soil, no sticky or sandy, no chalk; the peat bogs which extended here have long since drained, and become meadow soil; clayey loam, sandy loam, and meadow, compose the soil of the county. Dishley Farm, so well known, consists of a mild friable loam, of a good depth, on a clay or marl bottom.

Minerals: coal, lime, lead, iron, slate, and freestone; all worked. A mineral spring at Burton Lazars.

2. *Property.*

Estates generally large; that of the Duke of Rutland has been much improved, and always managed in the most liberal and benevolent manner.

3. *Buildings.*

Many very magnificent, as Belvoir Castle, Donnington Priory, &c. Farm-houses not built since the commencement of this century are of very inferior construction; timber and plaster covered with thatch. In general, the modern enclosed parishes have the worst farm-houses, they being almost always cooped up in the villages; in the more ancient enclosures, farm-houses have been erected in the midst of the occupations, and built with better materials. Dishley farm-house is of ancient construction, and has long since been built at different times, whence it wants regularity and compactness; it has, however, taken altogether a style of pastoral simplicity, united with neatness, and exhibits a specimen of that judgment and taste which joins convenience with economy, so far as it can be attained without regular design; the out-buildings too seem to have been put up at separate times, as wanted; the yards and pavements are remarkable for neat cleanliness, and the whole farm business for being conducted with good order and system. The houses of our principal breeders are comfortable and substantial, and of course fitted up in a style suitable to the taste and situation in life of the occupier.

Cottages generally in villages, and formed of mud walls and thatch; a few good new ones of brick and native slate.

4. *Occupation.*

Farms of all sizes, a great many from 80 to 100 acres, on which the farmers work with their own hands; near market-towns, many under 100 acres, occupied by tradesmen and manufacturers; general size, 100 to 200 acres; and those of the principal breeders, from 200 to 500 acres. Land chiefly in pasture for sheep, the dairy feeding cattle, breeding horses, and hay for winter use; dairy farms have also sufficient arable land to produce straw for their own use; the most fertile, inferior soils in aration. The Duke of Rutland has 2000 acres in hand, including the park, woods, gardens, &c. At Donnington, Lord Moira had 370 acres, under a Northumbrian bailiff; besides the park of 450 acres. Dishley Farm, near Loughborough, the occupation of the family of the Bakewell's for three generations, and now of Robert Honeybourne, nephew to the last Robert Bakewell, who died a bachelor, contains between 400 and 500 acres.

Irrigation is judiciously practised, and the culture of the arable uplands has been long conducted on so correct a system, that few weeds now come up; the most troublesome is chickweed. Heifers of three or four years old draw in the cart or plough, three of them form a team, and work nine hours a day. Farmers in general intelligent. Leases not universal.

5. *Implements.*

Plough with two wheels, and drawn by three, four, or five horses, or cattle in a line walking in the furrow. Thirty years ago, wheels were first applied to the fore end of the beam, and it was found that by pitching the ploughs a little deeper, and setting the wheels so as to prevent its drawing in too deep, the wheels were a sufficient guide, and the plough required one to hold it, except in places of difficulty; one man attending was therefore sufficient to drive on the team, turn the plough in and out at the ends, or guide it in particular hard or soft places. Soon after another furrow was added, by slipping an additional beam to the off side of the former, one somewhat lengthened, with foot share and shelboard; the same number of wheels, viz. one on each side, guiding the two furrows. Among the uncommon implements, may be included, a rack and manger for four cows on wheels, to be drawn from one pasture to another. It is square in the plan, and therefore each cow has a side to itself, and cannot kick or bite at the others; a break for shoeing oxen, a fastening for ewes, to lessen the fatigue of the ram during copulation, and also several ploughs, rakes, &c. the invention of Hanford & Co. at Hathern, near Leicester.

6. *Arable Land.*

Many farms have none. Drilling corn crops principally introduced; but not for turnips, even at Dishley; thought to lose ground; cabbages and rape a good deal cultivated on the soils too strong for turnips.

7. *Grass.*

Excellent meadows on the rivers and rills; fertilized by inundations; upland pastures sometimes manured. Stilton cheese made in most villages about Melton Mowbray. On the Trent, considerable patches of reed, which pay as well as the best meadow land.

8. *Gardens and Orchards.*

Gardens much wanted to cottages; orchards rather neglected, though the soil is in many places well adapted for them.

Poultry abounds owing to the prevalence of small farms great quantities sent to Birmingham and London.

Game, as pheasants, partridges, and hares, more than commonly abundant.

12. *Political Economy.*

Roads tolerably good, several canals; innumerable manufactures, especially at Birmingham, for iron, and others of the metal kind, and Coventry for ribbons.

13. *Means of Improvement.*

Leases; a more economical mode of laboring; draining; drilled root and herbage crops, and better rotations.

varied surface and fertile soil; distinguished by its pastures, and for the progress which has been made in the improvement of cattle and sheep. It is the country of Bakewell, whose name will ever stand at the head of breeding farmers. (*Monk's Report*, *Smith's Geological Map*, 1821.)

9. *Woods and Plantations.*

Few, excepting about gentlemen's seats, and in the hedgerows. Willows, as pollards, grown on Dishley and other farms, to supply the business, rails, and gates.

10. *Improvements.*

Elkington was a good deal employed by the proprietors. Irrigation more extensively practised in this county, than in most others.

11. *Live Stock.*

Cattle, the long horned breed. What was the particular breed of cattle in Leicestershire before the middle of the last century, about which time Bakewell began his exertions, it is difficult to determine; perhaps there was not any distinct breed, with particular specific characters, whereby they might be distinguished; although there were always great numbers bred, yet the produce was never equal to the supply of the county; there always was and still is an influx from Ireland, Wales, Scotland, Shropshire, Staffordshire, Herefordshire, Northumberland, and Lancashire; the latter of which were most probably the stock from which Bakewell began his breed. His first best cows, it is believed, were artfully obtained from Webster, of Canley, in Warwickshire; and his famous bull, Twopenny, was bred from one of these cows, or from one produced from Phillips, of Cringringham, and Bull from Northumberland. From these he began, with great judgment and attention, in a short time he reared some beautiful cattle; they were long and fine in the horn, had small heads, clean throats, strait backs, wide quarters, and were light in their bellies and offals; they were gentle and quiet in their tempers; they grew fat with a small proportion of food, but gave less milk than some other breeds. Some years ago Bakewell put three new milked cows in three separate stalls, a Holderness, a Scotch, and one of his own breed; the Holderness ate most food, and gave much the greatest quantity of milk; the Scotch ate less food, and gave less milk, but produced most butter; his own cow ate least food, gave the least milk, and made the least butter, but laid on the most flesh; hence it will follow, that the Dishley cattle are most adapted for the grazier, and the produce of beef. No man, perhaps, ever made more comparisons between the different breeds of cattle, than Bakewell, and no one that was able to tell so much, has told us so little about them. Many capital herds of cattle in the county, and a number of dairies, from which great quantities of cheese is sent to market.

Sheep, the present stock consists of three varieties, the old and new Leicester, and the forest sheep. The old breed, which is spread over Northamptonshire, Warwick, and Lincolnshire, are an improvement on the ancient stock of the common fields. The new breed Bakewell produced by breeding from selected sheep from his neighbors' flocks, or those of the Gibbers. A ram society was formed by Bakewell and others, and still exists, the object of which was a monopoly of ram-letting. The late Bakewell bound himself, and his successor, Honeybourne, binds himself, not to engage nor show his rams to any person, till the members of the society have seen them and are supplied, and not to let a ram to any person within fifty miles of Leicester, for a less sum than fifty guineas, for which, and other privileges, the society may a large annual sum; and Honeybourne, as well as every other member of the society, confine themselves not to sell, nor to let their ewes at any price, nor to show their rams at any public fair, nor at any other place than their own houses, and that only at stated times, from the 8th of June, to the 8th of July, and again from the 8th of September, till the end of the season; with several other regulations of a similar tendency.

Ram-letting alone has produced to Bakewell 5000*l.* in one year. The greatest price ever paid about 1789; since that time they have declined; still, about 1807, from sixty to 100 guineas has been given for the use of a ram for one season. Much curious information on this subject will be found in the report.

## Folding is not practised.

Fattening is practised as usual with grass, and in winter and spring with artificial food. Several frequently fattened sheep in stalls in three days they were reconciled to their confinement, and began to feed. "Further than this," the reporter's informant, Bakewell's successor, "knows not, or is not inclined to communicate."

The forest sheep are confined to Charrwood; they are grey-faced, and partially horned, but now almost extinct.

Horses have been bred in Leicestershire from time immemorial, and the best bred, and the best bred, Bakewell bought through Holland and Flanders and purchased some Friesland mares, which excelled in those points wherein he thought his own horses defective, from which, with great labor, expense, and judgment, he produced some capital horses, and in particular his famous horse Gee; the noblest, and most complete and beautiful creature of the kind that had been seen in Europe. How far his elegant points were adapted for the labor that horses of this sort are principally designed to perform, is questioned, but not determined; be this as it may, beyond all controversy he was strong and hard-om, and commanded the admiration of all who saw them; for a time he was the first subject of conversation, and almost the word of the day; he was taken to Tattersall's, and shown there to the nobility and gentry, with great approbation; and Bakewell did the honor of showing him personally to his Majesty; he is said to have been very quiet and docile, and Bakewell, in de-



scribing his points, invited his Majesty to touch him, which was declined. He was killed by lightning, in his pasture. The present horse-system at Dishley is this: three or four very capital black stallions are constantly kept; these are occasionally worked, and are always rendered docile enough for that purpose, if wanted; those kept at home cover at two guineas the mare, and those let out never at less than one guinea. Eight or ten brood mares, of the same stout black breed, are also kept, but no geldings; these do all the farming work of between 400 and 500 acres, with occasional assistance from the stallions, as well as from bullocks and heifers; of the mares, all that are fit are put to the horse, of which three are reckoned upon the average to rear two foals, allowing one in three for casualties.

Asses used in many parts of the county for carrying burdens, and lately introduced as farm's stock; especially for clearing green crops from clayey soils, in wet weather, their step being light. The turnip panniers open at bottom, to let out the load. Lord Moira had Spanish stallion asses, fourteen hands high, which he let out to cover at two guineas a mare.

**7014. DERBYSHIRE.** A mountainous and hilly surface of 622,080 acres of great variety of soils but more remarkable for its mining and manufacturing productions than its agriculture. It is, however at the same time both a corn and pasture county, and noted for its cheese; it is every where full of ingenuity and interest; and the Report by Farey, in three volumes, is one of the most interesting and valuable of the county reports: it is an extraordinary example of industry, research, and excellent general views, and will be read with great profit by every class of readers. (*Brown's Derbyshire, 1794. Farey's Agricultural and Mineral Survey, 3 vols. 1811 to 1815. Marshal's Rev. 1812.*)

**1. Geographical State and Circumstances.**

*Climate.* Cold on the hills, but mild in the plains; in the vales hoar frosts often injurious; no prevailing winds; rain about twenty-eight inches per annum.

*Soil* very various, chiefly calcareous.

*Minerals.* Lead and iron those chiefly worked; also some zinc, calamine, black jack, manganese, sulphur, &c.; coal, lime, alabaster, slates, freestone, paving stone, rolling, grinding, scythes, and cutlers' stones, and a variety of others, both for use and ornament, as spar, &c. Clay in some districts, as at Overmoor, is burned by spade-fuels, dried, and mixed with small coals in heaps, for the roads. E. M. Munday, Esq. of Shipley, formed his private roads of a sort of bricks, made without the corners to avoid the duty.

*Water.* When scarce, drinking ponds made by puddling and paving in the Gloucestershire manner. An artificial pond discovered in 1805, concealed under a nest, the head of which was puddled in the centre; a proof that puddling is no new art. Stone cisterns, placed in the lines of neatly-cut thorn hedges, serve to supply two fields: the water brought to them in thin zinc pipes, as being cheaper, and perhaps more durable, than lead.

**2. Estates.**

Of various sizes as in other counties; managed by attorneys, at a low salary, who make it up by law business and otherwise.

**3. Buildings.**

Chatsworth, Kedleston, and some other noble stone mansions in this county; some good houses, covered with cement, (known in London as Atkinson's) made from clay stones found in the neighbourhood in Yorkshire, and which Farey considers as superior to that made from the clayballs of the London clay stratum. Grottos frequent, fitted up with the spar of the county. At Ashover a trize of a chimney-piece, representing a section of the strata taken across the parish. At Chatsworth, and various places, the spits in the kitchens turned by water-wheels, of the overshot kind, supplied by small lead-pipes. Hair lines, in covered boxes, placed on drying parts, and the lines wound and unwound by a handle, for drying clothes. At several houses foot lath wheels, turning spindles, on which were other wheels, dressed with emery for cleaning knives; also brush spindles for boots and shoes, as at the Angel Inn, Oxford; boot-rack, in which boots are reversed on upright pins and taken off by a stick, which prevents dust settling inside the boot.

*Farm-houses* as in other counties; a few good ones recently erected. One of the most complete farm-houses is that of the Earl of Chesterfield, at Dretby Park; it is of hewn stone, slated, and combines a general farm yard, dairy court, and two poultry courts, including pheasantries. Buildings in general roofed with grey stone or other slate; water, in some cases, conducted down from gutters by a light wooden rod, down which the water runs as well as if it were in a spout or tube, and not blown about by the winds, as it would if no rod were there. Fire-proof floors made by arcing them with hollow bricks; in the cottages, cast-iron ovens on the side of the fire very common, and also iron cisterns for hot water; both these were originally brought into notice by the Griffin foundry, about 1778.

*Cottages* better than in most other counties; some good ones erected by the principal manufacturers and noblemen. Virgin's plow, or other beautiful flowering creepers, and shrubs, and banners, are not uncommon at the cottage doors in this county, among other indications of their attention to neatness and of their comforts, compared with the inhabitants of the miserable huts in many other districts.

**4. Occupation.**

Farmers generally of small size; farmers rank higher in intelligence than those of most southern counties; nothing but leases and larger occupations wanting to render this one of the most improved counties of England. Best farmers also at same time manufacturers or miners.

**5. Implements.**

Swing ploughs and pair; one-horse carts; good harrows (fig. 789); weeding scissors, for clipping off weeds among corn close or rather under the ground; weeding pincers; threshing machines; cast-iron rick-stands; cattle turning machines, mounted on posts, which turn round on a pin, so that when the cattle have well trodden the litter on the two opposite sides, in standing to eat from the crib, it is turned half round for them to tread and dung, &c. in the opposite direction. (fig. 790.) Turnip-slicers, chaff-cutters, bruisers, slate cisterns as milk vessels, &c.

**6. Enclosures.**

In setting out fences, less attention paid to separating the different kinds of soils than is requisite; walls frequent; and holes often made in them for passing sheep; to be closed when

Mules have long been in use for the saddle, road-work, and the plough.

Hogs greatly improved by various breeds. Honeybourne's seem to have a cross of the wild boar. Astley's is between the Chinese and Berkshire. At Donnington is a German boar, the bacon from whose progeny is of extraordinary sweetness and good flavor.

Bees attended to, but not so much as they deserve.

**12. Political Economy.**

The roads in the north-west of the county, in the neighbourhood of Loughborough and Ashby, are many of them laid out upon the concave system.

Bakewell and others were advocates for this system; but it does not appear that they are considered to be attended with any advantages by those who live beside them, and constantly use them. Various railways and canals. Manufactures, wool combing, woolen yarn, worsted, and especially worsted stockings; also cotton-works, hats, patent net-lace for veils, &c. The Leicestershire and Rutlandshire agricultural society established 1794.

not wanted by a flat stone; slacked lime plastered on the face of a newly planted hedge, (as clay is in Norfolk) to prevent the weeds from rising. Young thorn hedges, with a northern aspect, do best, as the morning sun in spring injures the bud of those facing the south when previously covered with frost,

789



Roots of thorns, sometimes planted as sets with success; old thorn hedges effectually renewed by cutting off the shoots below the surface of the ground; the roots then throw up vigorous shoots. Neatly clipped hedges at Ashbourne. Magnesian limestone, and marly soils found to suit the holly better than any other.

790

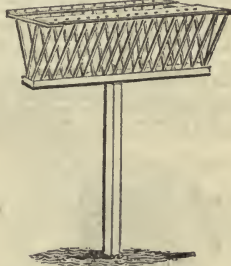

**7. Arable Land.**

Only one-fifth of the county in aration; formerly six horses were generally employed in ploughing, now only two; turnips drilled in the Northumberland manner in various places; some wheat drilled; oats a good deal cultivated, and oat-cakes or Haver (Ger.) cake made, by pouring sour dough on a hot stone; a sprinkling of parsley sown with clover to prevent cattle hoving; sides of oat ricks tucked in with a spade, to leave no loose straws for sparrows to rest on.

*Chamomile* is cultivated to a very considerable extent on the limestone and coal strata near Ashover; the flowers are picked by children; dried first in the shade and then on a malt-kiln, afterwards packed tight into bags, and sent to the London druggists; the crop stands three years, and then gets weedy and dec'ies.

Woad cultivated on a small scale.

*Widow-swort (Genista tinctoria)* infests old pastures, and is pulled when in flower, and dried and sold to the dyers.

*Yarrow (Achillea millefolium)* is in some places also taken up, tied in bunches, and dried for the dyers.

*Valerian (Valeriana officinalis)* is grown at Ashover, and also elecampane (*Inula helenium*), lavender, peppermint, and rhubarb, on a small scale, in one or two places.

*Truffles (Tuber cibarium)* collected in various places, especially under the shade of the beech trees, and on dry hedge banks. Roses formerly cultivated for the flowers, but not at present.

**8. Grass.**

Three-fifths of the county under permanent grasses, (though

it appears by the marks of ridges, to have been formerly every where arable), and the application, chiefly cheese-making. Droppings of cattle and horses on pastures spread by rakes, which injure the grass less than any other implement. Fern and other weeds collected from wastes, and dried and burned, and their ashes made into balls, and laid aside, to be used as ley for washing. This practice declines with the frequency of enclosures. When worms are engaged forming worm-casts in fields, scatter barley chaff, fresh and dry from the winnowing machine, which, sticking to the worms when they come out, prick them, and prevent their return to their holes, till rooks, &c. devour them.

### 9. Gardens and Orchards.

Good market-gardens at all the principal towns, and few of the farm-houses and cottages without gardens. "Samuel Oldknow, Esq. of Mellor, keeps a professed gardener, on three acres of rich sheltered land, by the river Goyte, on the Cheshire side of it, who cultivates, gathers, prepares, and delivers, all the useful vegetables and common garden fruits in season; his cotton mill work-people and tenants, and renders an account once a fortnight to the mill-agent, who deducts what they have purchased from the garden, from their several wages: the perfection and utility of his arrangement for these purposes cannot but prove highly gratifying to those who wish to see the laboring class well and comfortably provided for from the fruits of their industry. Proper rooms, for drying, cleaning, and preserving garden-seeds and fruits, and his cool-chamber, and other like offices, are attached to the gardener's house, and placed under his care." A most productive garden at Belper, on a very poor soil, but irrigated in winter from a cess-pool, in which centres the liquid manure of fifty cottages, belonging to Messrs. Strutt's cotton mills.

Orchards seldom planted, though the soil is well adapted for them in many places.

### 10. Woods and Plantations.

A good many coppices, the produce of which is much in demand both for mining and agricultural purposes. Sir Joseph Banks, at Ashover, has planted some exposed sites in a new manner; first planting narrow slips of Scotch fir at the distance of 100 yards, then intersecting them by others, so as to leave the surface checkered; after the Scotch firs are grown a few years, it is the intention to fill the intervening patches with larches, at such a distance as that they will never require any thinning. This plan, as Farey justly hints, is more ingenious or fanciful than likely to be useful; if the mixture of the larch and Scotch firs, with a proper attention to thinning, would be a more effectual, speedy, and economical mode of producing timber. Some judicious observations on pruning trees, and the propriety of Pontey's mode, pointed out by various examples. Hedge-row trees, sparingly introduced and well trained, are nearly all that fertile agricultural land ought to contribute to the national stock of timber. Key-bearing ash trees, or any forest tree much given to bearing seeds, no longer increases much in timber, and therefore ought to be cut down; hence male ashes preferable to females, or such as have both male and female flowers on the same tree. The use of the spray and buds of the oak as bark recommended, as practised in Cheshire and South Wales; when collected, they should be immediately sent to a mill and crushed. A most complete seasoning kiln for timber at Belper. Timber often sold by ticket sale,—thus described: the vender meets the proposed purchasers, writes his price in an envelope, and puts it in a glass; the offerers do the same; the vender opens the envelopes, and if any price comes up to his, then he accepts it, if not, the process is three times repeated, and then the vender must show his price, if none has come up, but not if any one has gone beyond it. In felling trees with an axe, cut *diagonal*, if young shoots are expected to succeed, as the sooner the centre rots the better the wavers thrive. Larch trees bear neglect better than any others, as they never produce timber boughs.

Birch wine has been made from an open grove of about 100 birch trees, near Overton Hall, for sixty or seventy years past. Thirty trees or more are tapped in a season, about six or eight inches above the ground, in March. A piece of bark, about three quarters of an inch in diameter, is cut out with a gouge, and the wood penetrated an inch or more; an iron spout (fig. 791 a.)

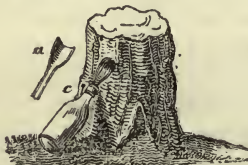

791

is then driven into the bark below the hole, which conducts the sap to a bottle (c). In warm weather the holes soon grow up, and will cease to run in four or five days; but in windy weather they will run for a month. Some trees will run twenty-four gallons in twenty-four hours, others not half-a-pint. The water is sold at sixpence a gallon, to those who make small wine as a substitute for small beer. If the water is scalded, (not boiled) it may be kept a month before it is made into wine; if not, it will not keep above a day or two. For making the wine, two pounds of coarse sugar, and a quarter of a pound of Malaga raisins, are added to every gallon of birch water, when cold: it is then boiled about an hour, until it is observed to grow clearer, when it is set to cool, and when about at the same heat that beer is set to work, a toast of bread, spread with yeast, is put into it, and for four days suffered to work freely, when it is barrelled, and the same quantity of raisins as before, and about an ounce of isinglass to every twenty gallons, are added: it seldom works out of the barrel, and in two or three weeks is ready for close bunging down, to remain for three months, when it should be bottled off, and in two or three weeks after it is fit for drinking, but is the better for keeping longer.

### 11. Improvement.

Magnesian or hot lime very thinly spread has its inimical properties; and it would seem such limes may be used where

a stimulant rather than an addition of calcareous earth is required. Lime over-burned melts and runs together, will not slack, and becomes useless; the consequence of too strong a fire being applied to magnesian limes more especially. Might not the dried mud of limestone roads be used instead of lime? Many bone mills in use: they are composed of ratchet-like iron wheels and rollers, between which the backbones of horses, with their adhering ribs, pass with facility, and are crushed into small pieces; the bones collected in London, from the church-yards and other sources; seven quarters dress an acre. Coal ashes almost entirely neglected, though a valuable manure. Importance in draining of bearing in mind the difference between surface and spring draining, and bog and upland draining.

### 12. Live Stock.

Cow stock for the dairy the prevalent stock in Derbyshire; no particular breed; noticed nine breeds and nine crosses of these. Many consider that rather poor land makes the best cheese, and old sward more and better than artificial grasses. In some places some staked and powdered lime strewed on the willow trees within the reach of cows, to prevent their eating them, and tasting the butter. Milk set to raise its cream in yellow dishes, with lips; in some places in slate troughs.

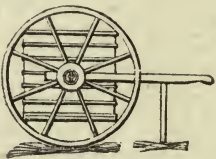

792

Sheep. Ten different breeds and seven crosses of these and others; wool chambers generally form a part of the accommodations of the farmer.

Horses. Those of Derbyshire ranked next to those of Leicestershire, for being stout, boney, and clean-legged.

Asses in considerable number used by the smaller manufacturers, and in the coal-works, potteries, &c.; also on the iron railways.

Poultry. The Earl of Chesterfield's poultry yards at Bretby perhaps as complete as any in the kingdom. The roosting house is well contrived, with covered places for the ducks and geese under the fowls, and the whole is constantly kept strewed with fresh saw-dust. The sitting-house, and which serves also for laying, is furnished with flues, to preserve an equal temperature in frosts. In the feeding-houses the fronts, partitions, and floors of the pens are all of lattice-work, which readily take out in order to wash them thoroughly; shallow drawers with fresh saw-dust pass under each pen to catch the dung. The fattening poultry are fed twice a day, and after each the food is taken away, and the day-light excluded, for them to rest and sleep.

A breed of brown American turkeys at Brailsford; they roost upon trees or the high parts of buildings; cocks weigh twenty pounds when fat, but the hens much smaller.

Geese when let out have a stick, almost two feet long slung before the breasts of the old ones, which is found to prevent them creeping through hedges, &c.; feed on festuca fluitans, &c. When waters are much impregnated with lime, the eggs of geese and ducks that frequent them, are so much thickened that hatching becomes difficult.

Hens. At Pleshy a fine breed of black fowls; round Wingerworth many game fowls kept for cocking. In Tansley the cockpit converted to a methodist meeting house. Eggs preserved hung in nets, and turned into a fresh position each day; this being the main essential in preserving eggs, whose yolks subside slowly when left unmoved, and come at length to touch the shells on the lower side, when rottenness almost immediately commences.

Bees kept in various places.

Fish. Certain ponds in Sir Thomas Windsor Hunlocke's Park, in Wingerworth, are appropriated to the feeding of contracted male carp and tench, which are found very superior in size and flavor to other fish: the late Sir Windsor Hunlocke saw this practised in Italy, many years ago, and had one of his servants, who was with him, instructed in performing the operation; which is less difficult or dangerous than might be supposed, and in consequence of which, not more than one in fourteen or fifteen of the fish die.

Angling permitted at Combs-brook reservoir of forty-five acres, the angler paying sixpence per pound for the fish taken. Salmon pass and trap on the Derwent, at Belper bridge.

### 31. Rural Economy.

Rewards are offered by the Agricultural Society at Derby, as by most others in the kingdom, for long and meritorious hired or day service, but seldom for having performed the greatest quantities of job work, or earned the most money by such at fair prices. At the beginning of the present century it was calculated, taking the laborer's wages at two shillings and sixpence per day, that he must work four and a half times as many days to earn the same quantities of food, as from three to five centuries back, he could, when his daily wages was fourpence to twopenny per day! Part of this was doubtless occasion

by the many idle saints' days which the church of Rome imposed on the people at the earlier periods.

#### 14. Political Economy.

Various concave roads formerly, made through the influence of Joseph Wilks Esq., of Measham; these in a very indifferent state, and illustrate the absurdity of the principles on which they are constructed. To level across a road a string level used. It consisted of a piece of box wood eleven inches long, one and a half broad, and one and a quarter deep, into the top of which a spirit-level tube was deeply sunk, and to the top, at each end of this level, several yards of strong whipcord was fastened. In using this instrument, a laborer was placed on each side of the road, having the cord in his hand, which they pulled very tightly and steadily against each other, and thereby made the bubble assume the middle of the tube or either end, according as the two ends of the string were held level or one higher than the other.

Some remains of wavy roads (3305.), but nothing to justify any deviation from the general form of slightly convex roads, with straight or even surfaces as to length. The road between Ripley and Little Eaton, where washing or irrigation has been adopted as a mode of clearing (*Com. B. Ag.* vol. i.), was "as miserably deep, loose, and bad."

In *Manufactures* Derbyshire ranks next to Lancashire, Staffordshire, and Warwickshire.

1. *Trades, &c. depending on the Animal Products of the county.*
  - Blanket-weaving, and scouring.
  - Bone-crushing mills.
  - Butter.
  - Button-moulds, of horn and bone.
  - Candle making, of tallow.
  - Carpet-weaving.
  - Cheese.
  - Curriers or leather-dressers.
  - Fellmongers.
  - Fulling mills.
  - Glue makers.
  - Leather mills for oiled, and shammy leather.
  - Meat, beef, lamb, mutton, pork, veal.
  - Shoe factory.
  - Skinner, or leather-dressers, shammy, &c.
  - Soap makers.
  - Stockings, of worsted.
  - Tan yards.
  - Woolen cloth factories, yarn spinning, weaving, and cloth dressing.
  - Worsted spinning, for the hoisers, by hand and jennies.
2. *Trades, &c. depending on Animal Substances, imported.*
  - Hat making and anspilt straw hats.
  - Silk-spinning mills.
  - Silk stocking weaving.
3. *Trades, &c. depending on Vegetable Productions of the county.*
  - Basket and wicket making.
  - Besom or broom do.
  - Boat or barge building, for the canals.
  - Breweries.
  - Chamomile flowers.
  - Charcoal burning and grinding.
  - Charcoal mills, for grinding it.
  - Corn, barley, beans, oats, pease, wheat.
  - Hoops for casks, of wood.
  - Malt makers.
  - Mattresses, chair-bottoms, &c. of straw.
  - Millers, flour or meal makers.
  - Sieves, or riddles for corn.
  - Shelling, or oat-meal mills.
  - Timber.
  - Turning mills, for wood, bobbins, bowls, cheese-vats, dishes, tool-handles.
4. *Trades, &c. depending on Vegetable Substances, imported.*
  - Bleaching-houses, and grounds.
  - Calico-printing.
  - Calico-weaving.
  - Cambrie-weaving.
  - Candle wick, bump or bomp-spinning mills.
  - Cotton-spinning mills.
  - Dye-houses.
  - Flax-spinning mills, linen-yarn mills.
  - Fustian-weaving, thicksets.
  - Hop-bag spinning and weaving, wool-bags, &c.
  - Lace-weaving, or warp frame-lace making.
  - Lace-working, or needleworking of frame lace.
  - Linen-weaving, sheeting, checks, &c.
  - Muslin-weaving.
  - Night-caps, of cotton frame knitting.
  - Pack-thread spinning, string, twine.
  - Paper-making.
  - Rope-making, cords, halters.
  - Sacking-weaving, corn-bags.
  - Sail-cloth weaving.
  - Stocking-weaving; principally of cotton, some of worsted frame-knit.
  - Tape-weaving mills.
  - Thread-spinning.
  - Whipcord-spinning.
5. *Trades, &c. depending on Mineral Products of the county.*
  - Bakestone making.
  - Boiler-making, of wrought-iron, for steam engines.
  - Brick-making, building, draining, fire, paving.
  - Building-stone, or free-stone, ashler, capping, eaves-slates, gable-stones, paving, ridding, grey slates, or tilestones and stack-posts.
  - Cannon-halls, or shot and shells.
  - Cannon-casting and boring.
  - Chain-making, iron and cast iron.
  - China-stone, or white potter's chest pits.
  - Cisterns and troughs of stone, to hold water.
  - Clay pits, brick, china, fire, pipe, pottery, and tile.
  - Coal-pits.
  - Coke-burning.
  - Copperas-stone, brasses or pyrites pits.
  - Frying-pans of iron.
  - Grind-mills, blade mills, grindstone mills.
  - Grindstones.
  - Gypsum, alabaster, plaster.
  - Hammer mills, forge, tilt, planishing mills.
  - Hoops for casks, of iron.

Iron forges and furnaces.

Ironstone pits, argillaceous ore.

Lead mines, or veins of lead ore.

Lead smelting cupolas, and slag-mills.

Lime kilns.

Limestone quarries.

Malt kiln plates, of perforated cast iron.

Marble quarries.

Marble sawing and polishing mills.

Marle pits, for manuring.

Mill-stone quarries.

Nail-making, of cast iron.

— clasp (or carpenter's), and spikes, &c.

— of zinc.

— horse shoe.

— shoe-makers.

Ore dressing, washing, buddling.

Patten rings, or clog irons.

Pipe-making, tobacco pipes.

Pipes, of earthenware, hollow bricks, for conveying water.

— of lead, drawn.

— of zinc.

Plaster of Paris works, gypsum.

Potteries, earthenware, stoneware.

Pot-stones, pye or lump stones for the iron forges.

Punchcons. staunchcons or props, for the coal pits.

Red lead works, minium.

Rivets, of iron, softened, for coopers, boiler-making.

Rolling and slitting mills, for iron bars, plate iron, nail rods.

Rotten stone, or polishing earth.

Sand-pits, casting or founders', house-floor, mason's mortar, scouring, and scythe-stick sand.

Saw mills, for stone and wood, also with circular saws.

Screws, carpenters', for wood.

Scythe-sticks and stones for sharpening scythes, hay knives.

Sheet-lead, milled-lead, rolled-lead. Common sheet-lead is cast by most of the plumbers and glaziers of the county.

Shot, leaden.

Slitting mills.

Spar-workers, petrification-workers, gypsum, calcspar, fluor.

Sulphur-works, annexed to the principal smelting houses.

Tenter-hooks, of cast iron, softened.

Tile kilns, draining, gutter, hip, pan, plane and ridge.

Tire for carriage wheels.

Whetstones, rubbers, hones.

White-lead works.

Wire-drawing, steel.

Wire-working, safes, safes, screens.

Zinc mines, blend and calamine.

— work, malleable plates, wire pipes, &c.

6. *Trades, &c. depending principally on mineral substances, imported.*
  - Axes, hatchets, bills, adzes.
  - Brass foundry.
  - Bridle-bits and buckles.
  - China factories.
  - Chisels, gouges, plane-irons, and other edge tools.
  - Clock and watch making.
  - Color-grinding mills, paint.
  - Cotton machinery makers, for the cotton-spinning mills.
  - Cutlery, knives, forks, &c.
  - File-making, rasps.
  - Flint grinding mills, for pottery glazing.
  - Frame smiths, stocking loom makers.
  - Glass-making.
  - Gunpowder making.
  - Hoes, (garden, turnip,) paring shovels, trowels, &c.
  - Implement-makers, agricultural tools.
  - Malt mills, steel mills.
  - Mangles, for linen cloths.
  - Mechanists, machine, tool and engine makers.
  - Millwrights.
  - Needle-making.
  - Reaping-hooks, smooth-edged.
  - Scissors, of cast iron, cemented to steel.
  - Scythe-smiths.
  - Sickles, toothed reaping tools.
  - Snuffers.
  - Soda water makers.
  - Spades, shovels.
  - Spurs, of steel.
  - Stirrup-irons of cast iron, cemented.
  - Tin-plate workers, tin-men.
  - Washing machines for clothes.
  - Worsted-machinery maker, for the worsted spinning-mills.

Notwithstanding that many of the manufactures and productions above-mentioned, are separately of small importance, and may contribute little or nothing towards an export trade from the county; yet, taken in the aggregate, they must be admitted to present a most flattering picture of the varied and great manufacturing industry of the county; showing it to contribute far beyond most other counties, towards the supply of all its own wants, and contributing at the same time, in no small degree, towards the supply and general trade of the kingdom at large.

#### Education.

Among the labouring classes, the reporter observes, is better attended to than in most of the adjoining counties. He approves of the great attention paid to bringing up children in habits of frugality and industry; and contemplates, as "the great and desirable end, their complete emancipation from the moral slavery of poor law dependence, and its attended ices and misery." There are some persons, no doubt, who may not approve of all that Mr. Farcy has advanced on this subject; for where is the writer that can please every reader? but there are none, we hope, who would not be gratified with his sincere and ardent desire for the more general and universal happiness of the British poor. Though we are of opinion that very little amelioration of that division of society which constitutes the agricultural or laboring class can be effected without an alteration in the laws; yet, we are equally convinced, that no great alteration of what are called the poor laws would be advisable, till the poor are prepared for it, by having imbibed such a degree of knowledge as would enable them to meet the consequences with advantage, or at least without an increase of misery.

We agree with the reporter, that the case is somewhat different with the operative manufacturers, and mechanists

congregated together in towns; for the wages of their labour depends, in most cases, as the wages of all labour ought to do, on the demand and the supply; whereas the weekly wages of the agricultural labourer depends too often on the decision of the parochial vestry. The consequences of this state of things are ruinous to the rural labourer, and call loudly for legislative interference, and general sympathy. The extraordinary exertions at present making by the different classes of mechanics, to enlighten and ameliorate themselves, cannot fail in a short time to awaken the dormant powers of the country labourer.

15. Means of Improvement.

There are reading societies in most of the principal towns :

7015. NOTTINGHAMSHIRE. 480,000 acres of uneven or hilly surface, in great part a sandy soil, and more a corn than a pasture county. It contains the Forest of Sherwood, the only one belonging to the Crown, north of the Trent. The report is one of the most defective and least interesting which the board have published, and is besides above a fourth of a century old. (*Lowe's Report*, 1798. *Marshal's Review*, 1812. *Smith's Geological Map*, 1821.)

1. Geographical State and Circumstances.

Climate, comparatively dry. Soil, chiefly sandy, great part clayey, and the remainder a lime and coal district.

Minerals. Stone, lime, coal, gypsum, and marl.

2. Property. Estates from 12,000*l.* a year, downwards.

3. Buildings.

Few countries contain more gentlemen's seats in proportion to its size. Alston Grove, a noble residence; and the gardens formerly in the ancient style, but lately modernised. Clumber Park, contains four thousand acres. Newstead Abbey, celebrated as having been the residence of the Byron family; but now sold and divided. Thoresby Park, thirteen miles round. Welbeck Abbey, the scene of the horticultural improvements of Mr. Speechey. Woolston Hall, a singular mansion of the date of Queen Elizabeth, by Horpe, the same architect who built Holland House, near London. Farm-houses "not very spacious," of brick and tile, sometimes thatched; now and then of stud and mud. Good farmeries, and central on the new enclosures.

7016. LINCOLNSHIRE. 1,848,320 acres of uplands, vale and water formed lands. The soil in most places rich, and chiefly devoted to grazing; yielding on an average more beef and mutton per acre, than any county in the island. Examples of embanking, draining, and warping, are numerous along the sea-coast and the Humber. (*Stone's Report*, 1799. *Arthur Young's*, 1794. *Marshal's Review*, 1812.)

1. Geographical State and Circumstances.

Climate, formerly unhealthy in the low parts, now the ague much less frequent. N. E. winds prevail in spring; much of the rain in summer from the northern and eastern quarters.

Surface, a great extent of low land, once marsh, and fen along the coast, now rich land in consequence of the embankments and drainings, which have been going on for nearly two centuries. Adjoining the lowlands are the wolds or calcareous hills, and the mainland part of the country is in general flat and uninteresting. Some parts of the county, however, as about Calby, Spilsby, Stanthorpe, &c. are varied and wooded, and command fine views of the low country.

Soil. There are large districts of clay, sand, loam, chalk, peat, and considerable extent of mixed soils.

2. Property.

Very much divided in the Isle of Axholme; inhabitants collected in hamlets and villages, and almost every one is proprietor and farmer of from one to forty acres, as in France; and as in that country, every farm cultivated by the hands of the family, and the family poor as to money, but happy as to their mode of existence. "The poorer farmers and other families work like negroes, and do not live half so well as the inhabitants of a poor-house; but all is made amends by possessing land." Lord Carrington, Sir John Sheffield, and the Goulton, Esq. great proprietors in the county; largest estate 25,000*l.* a year. Others of 14, 11, 10, 8, 7, &c. and six of 2000*l.* a year. Lately, a pretty village, "where each man lives on his own."

In the management of a great estate, "I remarked a circumstance at Revesby, the use of which I experienced in a multitude of instances. The liberality of Sir Joseph Banks opened every document for my inspection; and admiring the singular facility with which he laid his hand on papers, whatever the subject might be, I could not but remark the method that proved of such sovereign efficacy to prevent confusion. His office of two rooms, is contained in the space of thirty feet by sixteen; there is a brick partition between, with an iron plated door, so that the room in which a fire is always burning, might be burnt down without affecting the inner one; where he has 156 drawers of the size of an ordinary conveyance, the inside being thirteen inches wide, by ten broad, and five and a half deep, all numbered. There is a catalogue of names and subjects, and a list of every paper in every drawer; so that whether the enquiry concerned a man, or a drainage, or an enclosure, or a farm, or a wood, the request was scarcely named before a mass of information was in a moment before me. Fixed tables are before the windows (to the south), on which are spread maps, plans, &c. commodiously, and those labelled, are arranged against the wall. The first room contains desks, tables, and book-cases, with measure, levels, &c. and a wooden easel, which when open, forms a box-case, and joining in the centre by hinges, when closed, forms a package ready for the carrier's wagon, containing forty folio paper-cases in the form of books; a repository of such papers as are wanted equally in town and country. Such an apartment, and such an apparatus, must be of incomparable use in the management of any great estate: or, indeed, of any considerable business. At Wrintingham, Lord Carrington has a man employed, whose only business is to be constantly walking over every part of the estate in succession, in order to see if the fences are in order: if a post or rail is wanting, and the quick exposed, he gives notice to the farmer, and attends again to see if the defect is remedied." (*Young's Report*.)

3. Buildings.

Several good new farm-houses; old cottages of shed and mud, thatched; but new ones of brick, and tiled.

to be regretted that the funds of the board of agriculture do not permit it to circulate cheap agricultural books; agricultural books have as large a sale in Derbyshire as in most other counties; some take the "Farmers Magazine", and a great number the "Farmers' Journal"; which, if the stamp duty were taken off, would greatly increase in circulation, and be an incalculable source of improvement. An agricultural society at Derby, since 1794; a society for fat wether sheep at Repton: at Hayfield, a society of mountain sheep keepers, since 1790. A list given by Farey of ninety-three agricultural societies in England and Wales. The late Earl of Chesterfield's premiums annually to his tenants, as recorded in the Farmers' Journal, 27th December 1813, and 15th January 1816.

4. Occupation.

Few farms exceed 300*l.* per annum: generally from 100*l.* to 20*l.* Few leases.

5. Implements.

Rotheram plough general; waggons have wide frames movable for harvest use.

6. Various.

Enclosing going on rapidly; in arable culture, rotations good, but no remarkable practice mentioned; various hop grounds and orchards, many woods and plantations; extensive woods raised from seed on the Welbeck and Clumber estates; the ground is first cleared of surface incumbrances, then cropped with corn two years, and turns one year; the fourth year, acorns, at the rate of four or six bushels, ash keys four, hawthorn berries one, and spanish-chestnuts one bushel, are sown broadcast on an acre, and ploughed in. The stocking trade, cotton and silk manufacture, pottery, and various others carried on at Nottingham and other towns.

4. Occupation.

Farms on the Wolds, from 500 to 1500 acres, on the rich lands 400 and 500 acres, downwards; many very small. The late Sir Joseph Banks declined throwing his farms together, because he would not distress the occupiers, though he lost considerably in rental by it. Farmers met with at ordinaries, liberal, industrious, active, enlightened, free from all foolish and expensive shams, or pretence to emulate the gentry; they live comfortably and hospitably, as good farmers ought to live; and in my opinion, are remarkably void of those rooted prejudices which sometimes abound among this race of men. "I met with many who had mounted their nags, and quitted their homes, purposely to examine other parts of the kingdom; and had done it with enlarged views, and to the benefit of their own cultivation." Leases rare.

5. Implements.

Plough with wheel couler used in the fen tract as in other fens; the wheel couler being considered as better adapted for ploughing among stubble and couch grass than the sword one. Plans given of a cover of canvas and boards for ricks, and a boat with a net fence round for conveying sheep; at best, we fear, but an expensive incumbrance on agriculture.

6. Arable Land.

Near Market Deeping the common fields in alternate ridges of pasture and arable, the latter gathered high; three to five horses used in both plough and cart teams; wood extensively cultivated by Cartwright, at Brotherstoft farm, near Boston. Parsley sown along with clover to prevent the rot.

7. Various.

"Rich grazing land the glory of Lincolnshire." In some places will carry six sheep per acre, or four bullocks to ten acres. One of the most extensive graziers is T. Fydeil, Esq., M.P. at Boston. Very few orchards; some considerable young plantations on the Wolds, but not much old timber.

8. Improvements.

Most extensive drainages and embankments. Deeping fen-drained, which extends eleven miles to Spalding, 10,000 acres taxable, for maintaining the drains and banks, which are managed by a commission. Through all the fens what is called the soak exists; viz. water, supposed to be that of the sea, rising and falling in a substratum of silt; hence low-lying land always charged with moisture to a certain height. Sticklebacks sometimes sold at a half-penny a bushel, and used as manure. In the Wolds dry straw spread on the land and burned.

Embankments. Since 1630, 10,000 acres have been saved from the sea in the parish of Long Sutton, and 7000 acres more might now be taken in, by altering the channel of the river. Holland fen is a country that apparently exists but by the security of its banks; they are under commissioners, and very well attended to.

At Humberstone there is a large piece taken in from the sea by a low bank, which is well sloped to the sea, but too steep to the land, so that if the sea topped it, the bank must break. Great tracts of valuable land remain yet to be taken in from the sea about North Somercotes, and other places on that coast; but "I do not find that any experiments have been made in Sir Hyde Page's method of making hedges or gorse facines, and leaving the sand to accumulate of itself into a bank. Mentioning this to Neve, he informed me, that he had observed at least a hundred times, that if a gorse bush, or any other impediment, was by accident met by the sea, it was sure to form a hillock of sand." The extent of sand dry at low water on this coast is very great; the difference between high and low water mark extending even to two miles.

In the reparation of the banks which secure the marsh land from the sea, the frontage towns are at the expense; but in case of such a breach as renders a new bank necessary, the expense is assessed according to the highest tides ever known, by level over all the country below such level of high water, under the direction of the commissioners of sewers; the distance from the sea subject to drainage will, therefore, vary according to the level of the country.

South Holland, grossly estimated at 100,000 acres, within the Old Sea-dyke bank, has long been an object of embankment. The Ravenbank, the origin of which is quite unknown, appears to have been the third bank which had been formed for securing a small part of this tract from the sea, leading from Coult to Tidd St. Mary's. About six miles nearer to the sea is another bank, called the Old Sea-dyke bank, which is unquestionably a Roman work.

A very curious circumstance is, that a fifth bank, called the New Sea-dyke bank, two miles nearer than the Roman one, remains, but it is utterly unknown when or by whom it was made. The new bank mentioned above, takes in about two miles more in breadth. In staking the levels for making the new drain, it was found that the surface of the country, on coming to the Roman bank, suddenly rose six feet, being six feet higher on the sea side than on the land side, and then continues on that higher level, being the depth of warp, or silt, deposited by the sea since that bank was made.

The first navigable canal that was made in England, is, in all probability, that which was made from Lincoln to Torksey; it is evidently a part of the Cardike, an immense Roman work, which served to prevent the living waters from running down upon the fens, and, skirting the whole of them, from Peterborough to Lincoln, afforded a navigation of the utmost consequence to this fertile country.

7017. RUTLANDSHIRE. 91,000 acres, resembling in soil and surface the uplands of the adjoining county of Lincolnshire. The western part of the county is under grass, and the eastern chiefly in aration. The soil is almost every where loamy and rich; and the agriculture partaking of that of Lincolnshire and Leicestershire. The operative classes seem more comfortable in this county, and more humanely treated by the proprietors and farmers than in many others. The Earl of Winchelsea has made great exertions to this effect. (*Crutchley's Report, 1794. Parkinson's General Review, 1808. Marshal's Review, 1812.*)

1. Buildings.

Some comfortable cottages built by the Earl of Winchelsea, containing a kitchen, parlor, dairy, and cow-house, &c. with two bed-rooms over.

Others for three cows, and with a calf-house, piggery, dairy, kitchen, living-room, and two bed-rooms over. A third sort for operatives without a cow, containing a kitchen, pantry, closet in the stair over, and two bed-rooms, one with a fire. Several with small farms of from five to twenty acres attached. (*fig. 793.*)

793



2. Arable Lands.

Generally better managed than in Lincolnshire, and very productive. The barley said to be of very superior quality.

3. Pasture.

Chiefly upland. The custom of letting part of it to laborers, and also of taking in laborers' cows at so much per head, prevails, and is encouraged by the Earl of Winchelsea.

4. Several orchards.

In several places the cottagers take small portions of fields from the farmers to use as gardens. At one place, three acres and a half is divided into fourteen gardens, and at Oakham a field of three acres is divided into twenty-four gardens, and let at five shillings per garden.

5. Improvements.

Parkinson, one of the reporters, and a man of sound judgment, has altered his opinion on the subject of irrigation, and says it is now in conformity with that of a correspondent who

Some irrigation; and maring, on the Humber, where, as already described, (4117.), it was invented.

9. Live Stock.

More attended to in this county than the culture of corn. The Durham short horned cattle are preferred, but any sort fatten well, and there is little dairying.

Sheep. County carries one sheep and a half per acre at an average. Lincoln breed preferred, Leicester much tried, and crosses between them frequent; upon inferior land the Leicester preferred, as fattening easier; since the enclosure no folding; several ram societies.

Horses. Of the heavy black kind a good deal bred both for carts and coaches; in various places saddle horses also; some farmers keep their horses all the winter in open sheds, with littered yards for them to go out and in at pleasure. Ground-sell eaten, said to cure the grease; oats malted in salt water given for three weeks or a month, found preferable to spring physic.

Rabbits. Several warrens on the wolds.

Geese formerly much kept in the fens, and plucked four or five times a year. The feathers of a dead goose worth six-pence, three giving a pound. But plucking alive does not yield more than three-pence per head, per annum. Some wing them only every quarter, taking ten feathers from each goose, which sell at five shillings a thousand. Plucked geese pay in feathers one shilling a head in Wildmoor fen.

10. Political Economy.

Roads in many places made of silt; "dreadfully dusty and heavy in dry weather: on a thaw or day's rain like mortar." A number of canals, and, as already observed (3530), the first in England made from Lincoln to the sea. A fabric of brushes and sacking at Gainsborough; flax spun in various places. An agricultural society at Falkingham, established in 1796.

thus writes to him:—"In my opinion watering renders the quality of the herbage and the land the worse for the process. Where land is tolerably productive, and in a situation where a quantity of grass food is not required, should certainly not advise it. I think the land may be turned to better account without it. But I think there are many situations, particularly on gravel, sand, or open soils, where it may be very advantageous; the produce, by such means, is certainly much increased, and, in some instances, rendered larger when very little other wise would be produced. Though the produce is increased, yet it becomes in time, in a few years, of so coarse a nature, and mixed with rushes and plants, that cattle frequently refuse to eat it; and when it is eaten, the appearance of the cattle proclaims it far from being of a nutritious nature." He adds, "I was formerly an advocate for irrigation, and an still on such soils as are described in the above extract; but having had several opportunities of viewing several water meadows which have been of long standing, which have operated to the disadvantage of both the herbage and land, I have been obliged, in a great measure, to alter my opinion."

6. Live Stock.

Not much breeding, but chiefly feeding. P. considers that much depends on the application to fallow, and is of opinion, that the large Durham ox did not seem more food to raise him to that enormous size than some other women; to bring them to half the size or weight at the same age. Nor is it at all probable, that Lambert, of Leicester, who arrived at such an astonishing weight, had eaten more food than Powell, the celebrated pedestrian, who was a very thin man. An animal for the shambles is seldom too large if he has an aptitude to fatten; and much depends on the constitution of an animal in this respect.

A good plan for washing sheep at Burleigh; but not so simple as the Duke of Bedford's.

Horses of a very heavy, slow, unprofitable sort are raised in the county.

Of bees, 1176 hives kept by the cottagers.

7. Political Economy.

The Leicestershire and Rutlandshire Agricultural Society established in 1806, meet at Melton Mowbray, and Oakham, alternately. Less want of knowledge in this county than in most others.

7018. NORTHAMPTONSHIRE. 617,600 acres of billowy surface, rich in wood lands and pasture lands, but much behind in the culture of corn. The soil is almost every where excellent; and by the introduction of good husbandry, the marketable produce of the county might be amazingly increased. (*Donaldson's Report, 1794. Pitt's Report, 1806. Marshal's Review, 1812.*)

1. Geographical State and Circumstances.

Climate. Favorable both to health and vegetation; exempted from deep falls of snow and long-continued rains; highest point in the county supposed about 800 feet above the level of the sea, and there is neither mountain nor bog. Donaldson found that wheat harvest generally commences here about a fortnight earlier than in Fethersham.

Soil. Great part of calcareous bottom, limestone, schistus, or slate, and the remainder of sandstone. The surface earths may be classed as strong and deep loam, light thin reddish soil, thin light clay, and fen and meadow.

Minerals. Clay, limestone, marl, freestone, and slate.

2. Property.

Almost wholly in large estates; thirty-seven of or above 3000l. a year, half of which are from 5000l. to 10,000l.; managed by stewards.

3. Buildings.

Althorpe, Burleigh, and Castle Ashby, noble mansions. Farm-houses "as badly constructed as improperly placed;" built of stone or brick, and covered with slate or straw; farmers and their farmhouses crowded together in towns and villages; cottages of mud and thatch.

4. Occupation.

No large farms; 130 acres the average of open fields, and 200 the average of inland farms; few or no leases.

5. Implements.

"Plough a clumsy piece of work, with a long massy beam and timber mould, being drawn by four or five horses in a line." Donaldson says, a small plough, with two horses abreast, will make better work; but Pitt (who seems to know very little of the matter) joins with Smith, of Tuchmarsh, who says, "I have heard and read much on the subject, and tried a great variety of ploughs, but it is ridiculous to assert that two horses can plough abreast in almost any part of this county. I have met with no ploughs which serve so well (!) or run so easy as the ploughs in common uses." So much for the ignorance and presumption of Farmer Smith, and the prejudiced opinions of Pitt the reporter. A ribbed or plated roller, formed by letting in sixteen bars of iron lengthwise of the roller, is found preferable either to a spiky or smooth roller for breaking clods.

6. Arable Land.

Fallow, wheat, and beans the common rotation, but others which include turnips and clovers, beginning to be introduced

on the light lands. Most of the other plants in cultivation tried by amateurs or others. Woad cultivated by two woad growers, which the woad grower pays the landlord from 5*l.* to 7*l.* per acre per annum, for two or three years, the farmer being compelled to give it up for that term, and to take it to again afterwards, at the old rent. The land is ploughed early in spring, well barrowed, and sown broadcast, as thick as grain, by hand-fuls; a great deal of harrowing and dressing is necessary to bring it to fine tilth. When the plants appear, they are hoed, and kept perfectly clean, in a garden style of culture, and the crop appears somewhat like a broadcast crop of spinach; the leaves are gathered by hand, in baskets, three times in a season, (except a plot sometimes saved for seed) and carted to a mill, where they are ground to a pulpy mass, by vertical wheels, crossed with iron plates, and moved round by horses; this pounce, or jelly, is then formed into balls, by hand, and dried on hurdles, in a shed; these balls are afterwards broken up, and fermented, and finally dried in small lumps, somewhat resembling horse-dung in color and appearance; it is then packed up in casks for use.

Onions cultivated to great perfection about Northampton; 220 quarters known to have been sent to Daventry fair at one time.

Tobacco cultivated by some farmers for the purpose of dressing sheep for the scab.

Furze in a few places for oven fuel.

### 7. Grass.

Supposed to cover 375,000 acres; 40,000 acres in meadow, on the borders of the Nen and other rivers. One farmer says, "a great improvement on all mowing-meadows, incapable of being watered is, to graze, once in two or three years, as bare as possible, and finish with store sheep; shut it up at Christmas for mowing; this is as good as a top dressing." Feeding sheep and cattle the chief application of the grass lands, and next, dairying and breeding horses.

### 8. Gardens and Orchards.

Good market gardens and orchards about Northampton; all common articles grow there well, but melons, grapes, peaches,

7019. YORKSHIRE, 5,698,380 acres divided into three Ridings, each of which is as extensive as the generality of other counties.

7020. WEST RIDING OF YORKSHIRE, 1,568,000 acres of irregular country, hilly and mountainous towards the north and more level on the east. It contains a great extent of surface well adapted for husbandry, and is the seat of large and extensive manufactures. A survey of this Riding, of singular ability and interest, was made by three Scotch farmers; and the reprinted copy, as it contains the notes of several gentlemen of the county, will in future times be considered as a curious document; displaying as it does local opinions so different from those considered as liberal and enlightened. (*Brown's West Riding*, 1799. *Marshal's Review*, 1818. *Smith's Geological Map*, 1821.)

### 1. Geographical State and Circumstances.

Climate, moderate and healthy, excepting on the low surface near the Ouse; rain at Sheffield about thirty-three inches in the year.

Surface irregular, but the middle and eastern parts nearly level; arable lands generally enclosed with walls and hedges.

Soil various, from deep strong ley to peat.

Minerals. Coal, lime, ironstone, lead and some copper, which have been wrought for ages past.

Rivers. Ouse, Don, Calder, Aire, and Wharfe, all considerable, besides others of lesser importance.

### 2. Property.

Much divided, but some large estates, as those of the Duke of Norfolk, E. Fitzwilliam, Lord Harewood, &c.

### 3. Buildings.

Wentworth House one of the largest and most magnificent in the kingdom; farms, houses bad and badly situated as in most English counties; Lord Hawke has erected a commodious and elegant farmery for his own use. Great want of cottages for farm operatives.

### 4. Occupation.

Farms small for one of 400 acres, a dozen under fifty; occupier of 100 acres styled a great farmer; few leases; the tenants on one estate warned off because they had become methodists; tenantry in general much plagued by attorney stewards, who must have business or make it.

### 5. Implements.

Rotherham plough general over the whole district, but one horse carts and other improved implements as well as better ploughs are wanting.

### 6. Arable Land.

Round manufacturing towns, great part of the land held by manufacturers, that by farmers not well managed compared with Scotland, but tolerable compared with other districts of England. No grain will ripen on the eastern moorlands at an elevation of 900 feet; but on the calcareous wolds of the East Riding it ripens considerably higher, and at 500 feet better than here at 800. Such is the effect of a calcareous soil. Besides the usual crops, some flax, rape, liquorice, rhubarb, and weld cultivated. Some excellent remarks on fallows.

### 7. Grass.

Great part of the county under old pastures, including some meadows, chiefly applied to the feeding of horned cattle; cat-

7021. NORTH RIDING OF YORKSHIRE, 1,311,187 acres of bold hilly country with some fertile vales and extensive moor lands chiefly remarkable for breeding horses, and especially the sort known as Cleveland bays. (*Tuke's Report*, 1799. *Marshal's Review*, 1808. *Smith's Geological Map*, 1821.)

### 1. Geographical State and Circumstances.

Climate dry like that of other districts bordering on the German Ocean. Cold east winds during the first half of the year. Milder in June, when west winds begin to prevail; vegetation not vigorous till June.

Soil and surface: on the coarse clays, and lighthill soil on alum strata; a deep upon freestone, and in some valleys west of Whithy a loam rich soil; of Cleveland fertile chalk and surface hilly; vale of York ripens considerably higher, and at 500 feet better than here at 800. Such is the effect of a calcareous soil. Besides the usual crops, some flax, rape, liquorice, rhubarb, and weld cultivated. Some excellent remarks on fallows.

Minerals. Inexhaustible beds of alum in the hills of the coast of Cleveland; and the only alum works in the island carried on there; pyrites being found in the alum mines sulphur

and pine apples to be had from London, cheaper than they can be grown in the county.

### 9. Woods and Plantations.

Very extensive; there are forests, chases, parkwoods, and woods and plantations being freehold property. Rotherham forest the most considerable, nearly twenty miles in length, and covering 8 or 10,000 acres. Whitlewood eleven miles, and 7000 acres, with Saiccy forest, making in all 20,000 acres; the chases and other classes are supposed to amount to 20,000 acres more, making in all 40,000 acres of woodland in the county. The forest lands are in general very unprofitably managed; the Crown has a right to the timber, the Duke of Grafton and others to the underwood, and the township to the pasturage, &c.; woods which are private and entire property, are better managed.

### 10. Live Stock.

Cattle of the country, the long horned breed, but various; others introduced for fattening and the dairy.

Sheep of various breeds; a good many new Leicester.

Horses of the strong black breed, bred for the coach, the army, or large waggons. Blood horses formerly bred, but left off, as the least blenheim renders them unsaleable.

Hugs, a breed between the Berkshire and the Tonquin.

### 11. Political Economy.

Bad roads but many handsome bridges; some canals. Manufactures;—shoes for the army and navy and exportation, bone lace, woollen stuffs, as taminies, callimancoes, and everlastings. Several small friendly societies for the promotion of agriculture, consisting chiefly of farmers. The Lamport society is one of those which was founded in 1797, meets at Lamport; it has a fund for purchasing books on agriculture and domestic economy, and seems to be a description of association very commendable. A great source of improvement would be the breaking up of the inferior grass lands and the temporary laying down of the continually cropped tillage lands. Donaldson has drawn an able comparison between the management of lands in the Garse of Gowrie in Perthshire and those of Northamptonshire; which shows how very far behind the latter county is in arable culture.

te generally made fat on grass and finished by stall feeding on turnips; sheep sometimes fed on turnips, by hurdling. Grazing much better understood than aration.

### 8. Gardens and Orchards.

A particular species of plum grows at Sherborne, and in the neighborhood, called the winesour. It grows well both upon gravel and limestone, is hardy, a good bearer, and answers upon any soil; but does not bear so well, nor its flavor so good on any as on limestone or gravel. On a strong deep land, the trees run too much to wood, and do not bear fruit in proportion. These plums blossom better than any other sort, and are produced from suckers. The fruit sells from 2*l.* per peck, when sound and good, to 4*l.* 6*d.* when cracked and damaged. They are easily hurt by rain. Plants are to be had from most public nurseries, and in gardens they should be planted on a layer of lime or chalk.

### 9. Woods and Plantations.

Much oak and ash wood grown, and a ready market found at the shipping and manufacturing towns.

### 10. Waste Lands.

Two hundred and sixty-five thousand acres capable of cultivation.

### 11. Improvements.

Warping the most remarkable; ably described by Lord Hawke, and Day of Doncaster.

### 12. Live Stock.

A great variety of breeds of cattle and sheep in use, but no one generally preferred. Near Leeds, when milk tastes of turnips a tea cupful of dissolved nitre is put among eight gallons of milk which entirely removes the flavor. Horses generally used in draught, not many bred excepting in the eastern part of the district; sort in use among the farmers a small hardy race.

### 13. Political Economy.

Many good and many bad roads, various canals. Numerous manufactures of shalloons, callimancoes, flannels, and every branch of woolen goods. At Sheffield every kind of cutlery, and the most improved iron goods. These and other manufactures the cause of the wealth of the West Riding.

### 14. Means of Improvement.

Leases, division of commons, enclosing of wastes, better rotations, &c.

was formerly extracted from them, but as it required a good deal of coal, and pyrites are equally abundant in the coast at Newcastle, the manufactory of sulphur was transferred to the latter place. Some coal and ironstone in the moors, but not much worked; also copper, lead, freestone, slate, marble, marl, &c. little worked or abandoned.

### 2. Property.

One third of the Riding possessed by yeomanry; rent of estates from 50*l.* to 15,000*l.* per annum; many gentlemen's seats and the proprietors reside most part of the year on them; tenures mostly freehold.

3. *Buildings.*

Mansions and farm-houses, as in the West Riding, but rather inferior; cottages decidedly inferior; small and low, rarely with two rooms; damp and unwholesome hovels. Close wainscoted beds used, as in the poorer parts of Scotland, which are sources of insects and infection, and every way unwholesome.

4. *Occupation.*

Farms on the whole small, many very small: farmers sober, industrious and orderly; most of them have been educated, and educate their children. Few leases.

5. *Implements.*

<sup>1</sup> *Rotheham* or Dutch plough: hay sweep for drawing hay together, with a horse, and a simple sort of cart (*fig. 791 a.*) in

794

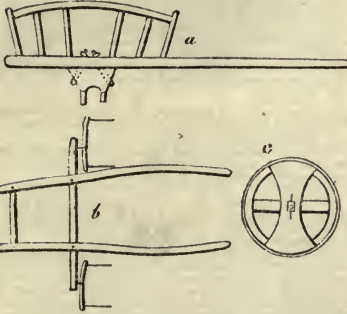

use, formed almost wholly of timber, and to be drawn by one, two or three horses abreast (*b*); wheels entirely of wood (*c*); when to be emptied, the shaft horse is taken out, but not the others. Another variety for harvest work (*fig. 795.*)

795

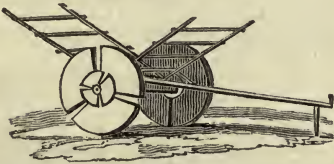

6. *Arable Land.*

In the vale of York one-third in tillage; about Cleveland one-half; on the moors much less. Culture and rotations as in the West Riding. Rye more frequently sown than wheat on the light sandy soils; often mixed with wheat, and then called *Meslin*.

Tobacco much cultivated a few years prior to 1782 in the vale of York and Ryedale. In the latter district it did not excite the notice of regal authority; and was cured and manufactured by a man who had formerly been employed upon the tobacco plantations in America; who not only cured it properly, but gave it the proper cut, and finally prepared it for the pipe. But in the vale of York the cultivators of it met with less favorable circumstances. Their tobacco was publicly burnt, and themselves severely fined and imprisoned. Penalties, it was said, were paid to the amount of thirty thousand pounds. This was enough to put a stop to the illegal cultivation of tobacco. But, perhaps rather unfortunately, it has likewise put a stop to the cultivation of that limited quantity half a rod, which the law allows to be planted for the purposes of physic and chirurgery, or destroying insects.

*Mustard* grown in considerable quantities in the neighborhood of the Riding. It is prepared for use in the city of York, where there are mills and machinery for the purpose; and it is afterwards sold under the name of Durham mustard; sown either on land pared and burned, or prepared and manured as for turnips. Seed, one to two pecks per acre broadcast, in the early part of May. No culture whilst growing, except hand-weeding, if necessary. Shorn with the sickle in September, and generally stacked in the field, and threshed out upon a cloth, at the convenience of the farmer. Two quarters per acre is thought a good crop.

*Teasle* grown on strong soils; seed, two pecks a little before May-day; surface dug or forked over in June, October, and May-day; raised in August; 10 pecks an acre a good crop; each pack 1350 bunches, of ten teasles each; price, 3 to 5 guinea per pack.

7. *Grass.*

Old pastures and meadows very badly managed; uplands overrun with moss and ant-hills; meadows with rushes; and so neglected, that what would be worth 200*l.* under a proper course of husbandry, is dear at 7*l.*; chiefly devoted to the dairy.

8. *Gardens and Orchards.*

Have made but little progress in this Riding owing to the

want of manufacturing towns to create a demand; and farmers' gardens, as in most places, much neglected.

9. *Woodlands.*

Of small extent; a good deal of timber in hedgerows in various places.

10. *Live Stock.*

Short horned cattle chiefly prevalent. Stall feeding carried to less extent than dairying. Cows taken in at Martinmas, and fed on turnips, and straw or hay if there are no turnips; but chiefly made and salted in firkins, and sold to the factors, who ship it to London; a good many cows brought up for London, and any surplus stock for the Lincolnshire graziers. Sheep, of the blacker breed, the Cleveland breed, large coarse boned slow feeders, and the wood dry and harsh. All the new breeds introduced, and several professed ram breeders in the vale of York.

*Horses.* This Riding long famed for its horses, particularly those of Cleveland. In the northern part of the vale of York a light breed for saddle and coach; in Cleveland, a fuller boned horse, very strong and active, and well adapted for either plough or coach. In all the other districts horses are either plough or coach. On the western moorlands Scotch galloways generally bred; on the western moorlands Scotch galloways are put to the stallions of the country, "and rear a hardy and strong race in proportion to their size." Before the war mules were bred and sent to the West Indies. Some farmers do not breed, but buy colts and work them till four or five years old, and then shew them for the first time, and sell them to the London dealers for coach horses.

The farmers who breed horses, generally breed from those mares which are employed in the business of the farm; these are often worked until the very time of foaling, after which they have usually two or three weeks rest, before they are again taken to work: the foal, during the time the dam is working, especially whilst it is young, is shut up in a stable; and it is the practice of some, before she is suffered to go to the foal, after returning from work, to use her udder with cold water, and to draw most of the milk from it, to prevent the milk, which may have been heated by labor, from having any hurtful effect upon the foal. Some continue this practice as long as the foal sucks; others, after the foal has got sufficient strength to travel along with the mare, take it along with her into the fields, and frequently suffer it to suck, from an opinion, that by the milk being frequently drawn, less danger arises of its being heated, or of possessing any quality prejudicial to the foal. The general time of foaling is about May-day (from which day the age of all horses is reckoned), and that of weaning, about Michaelmas, when the foals are put into good after-grass, or the best pasture the farmer possesses; they remain there as long as the weather permits (if there be sufficient food), and, on the approach of winter, have a little good hay given them, where there is a stable, or hovel, that they can go into at their pleasure. The colts are usually gelded in the spring following, and in summer are allowed only an inferior pasture; the next winter they make their living in the fields, or in the straw-yard, except they are intended to work in the spring, which is frequently expected of those of a strong kind: such are rather better kept as the time of labor draws nigh, and are only put to light and easy work, and generally work only half a day at once, some keep their colts a year longer, before the operation is performed, and find that such become the stronger and hand-omer horses. The foal always receives a great check by being weaned, which it does not well recover before it gets the fresh pasture of the following summer. The foals which are gelded at one year old, receive a second check, at the very time they should begin to recover from the first; whereas, at two years old, they appear to be in the best condition for the operation, and recover at least as well as at one year old, and are much improved by the keeping of the preceding year.

*Exportation of horses.* The horses which are sold for the London market, if for the carriage, are chiefly bay geldings, with but little white on their legs and faces, those which have much white, with chestnut, roan, and other unusually colored horses and mares, generally do not bear an equal price in the London market; but with other slight and undervalued sized horses, are more sought after by foreigners, and eagerly purchased by them for exportation; or are exported by people of this country, who carry them to the foreign markets, and ultimately obtain a price equal to that obtained for those sold at home: by these means the exportation, contrary to an usually received, but ill founded opinion, has a strong tendency to reduce the price of those horses which are calculated for the home market; and since as many fillies as colts are naturally bred, and one-third of the colts at least will either have too much white for the home market, or be of some other color than that which is fashionable at the time, if the breeder had not a market for those, which appear to be two-thirds at least of all he unavoidably breeds, he would be compelled to put such a price upon the one-third which happens to suit the foreign market, or variable at the moment, as would pay for the other two-thirds; which last would either be unsaleable, or fetch very inadequate prices. The consequence naturally flowing from this would be, that the price of horses used at home would be far greater than at present, when a foreign demand procures to the breeder nearly as good a price for the horses that would otherwise be useless and unsaleable, as for those which are valued at home.

*Rabbits* are kept in one or two warrens; in one the silver grey is kept; the skins of this variety being worth double those of the greys: not used for felts like the common skins, but dressed as furs, and exported to China to be worn by the Mandarins.

11. *Political Economy.*

Roads in an improving state; bridges better attended to than in most counties; but guide-posts neglected, which an amاتور on Tuke's report justly remarks, is a sort of reverting to barbarism; as an attention to these sort of minutiae, is one of the most striking marks of civilization. Various canals.

*Manufactures* of sail cloth and cordage at Whitby and Scarborough; at various places in its neighborhood, alum works; 4000 tons of this article annually shipped from Whitby; linens, cottons, woollen, and paper manufactured in various places.

**7022. EAST RIDING OF YORKSHIRE.** 819,200 acres of moderately wavy surface, intersected with numerous deep winding vallies; with remarkable either for its arable lands or pasturage; but productive of horses for the coach and saddle, and of the excellent Holderness breed of cows. (*Leatham's General View, 1794. Strickland's View, 1812. Marshal's Review, 1812. Smith's Geological Map, 1821.*)

### 1. Geographical State and Circumstances.

*Climate* of the wolds severe and variable; N. and N. E. winds prevail in winter and spring; in the vales milder; mild, but not very healthy, on the Humber; rain at Hull, twenty-seven inches and a half yearly at an average.

*Soil* of the wolds calcareous (part of Holderness, fertile clay and stiff retentive clay). On the banks of the Humber, from Paul, nearly to Sperrn Point, there are thirteen or fourteen thousand acres of warp-land, of a strong clayey loam, the productiveness of which can hardly be equalled.

*Sunk Island* on the Humber is a modern creation by that estuary: it first began to show itself about 1667, at ebb tide, and as no man pretended title to it (it being a detached island), a grant of it was made by the crown in the same year. In 1775, 1600 acres of the land were embanked and under tillage, producing a rental of 900*l.* a year, with a chapel and several farm-houses erected on it. That part of Sunk Island which was first embanked, was originally about two miles from the shore, and many persons are still living who recollect vessels passing between it and the mainland, to which it is now united by a bridge across a narrow channel, serving as a drain to the adjacent country. It contains at present within the banks about 4700 acres, and twenty-four families, and is continually increasing in size, an extensive tract having been recently embanked, with a probability of its being still further enlarged.

*Minerals.* Chalk and a very hard shelly limestone, producing a lime little valued either by the farmer or builder. Chalk of the wolds much harder than that of the southern counties. Marl in many places. Gypsum in some places, but no mineral veins or coal, and in many places not even clay for bricks.

### 2. Property.

Less divided on the East Riding than in other parts of the county; perhaps less than in most parts of England, which arises a good deal from the nature of the county: one half of wolds where land is held in little estimation, and occupied in larger tracts; the other a flat low country, partly rich and clayey, and partly sandy and barren. Most of the families have possessed their estates for many centuries, and some from the Norman conquest: largest 15,000*l.* a year, ten at 10,000*l.* a year. Only three noblemen have seats in this Riding.

### 3. Buildings.

Seventy-four manorial houses, of which twelve are going to decay, nineteen let to tenants, or remain empty; forty-one occupied by their owners (*Temp. Eliz.*); ninety-two families bearing arms resident in the county.

*Farm-houses* generally good, excepting on the wolds, where they are built of chalk, thatched, and miserably bad; generally in villages, excepting those built lately.

*Cottages* more comfortable than in many places, generally two rooms below and two bedrooms over them; a disposition in the proprietors to let their cottages go to decay.

*Village cow club.* A plan for insuring cows having been lately adopted on an extensive scale, and with striking success in the north of Lincolnshire, from which it appears that an average payment of about three half-pence per cow per week, (or six shillings per year), is fully adequate to replace the ordinary losses of cows by death; it is proposed to institute a similar club in the contiguous parts of the East and North Ridings of Yorkshire, with a view of securing to the laborer and his family a more certain and the great benefits of that useful animal, without his risking more than one-sixth part of her value, upon certain conditions.

### 4. Occupation.

Farms in general small; one or two of 1200*l.* per annum, but from 200*l.* to 20*l.* more common. Leases so rare that the surveyor could not recollect of one, unless under suspicious circumstances, where something incorrect is aimed at: some advantage intended to be given or taken: where either the landlord wanted to get more than his due, or the tenant, or the tenant was disinclined to trust his landlord: great estates are let in full confidence in this Riding, where a lease was never asked for, probably never wished for; because the tenure is equally secure, and more permanent without than with one. Many estates have been occupied by the progenitors of the present tenants, during two, three, or four generations.

### 5. Implements.

Waggons here of a bad construction; but well yoked in the German manner. The four horses are yoked two abreast, in the same manner as they are put to a coach, two drawing by the splinter-bar and two by the pole; those at the wheel drawing also by a swinging bar, which the wheel horses of every carriage ought to do, as they thereby obtain considerable ease in their draft, and are less liable to be pulled by the collar than those which draw by a fixed bar; the driver then, being mounted on the near side wheel horse, directs the two leaders by a rein fixed to the outside of each of their bridles, they being coupled together by a strap passing from the inside of each of their bridles to the collar of the other horse. In this manner when empty, they trot along the roads with safety and expedition; and when loaded, the horses being

near their work, and conveniently placed for drawing, labor with much greater ease and effect than when placed at length. Were the waggon indeed of a better construction, the team would be excellent.

The pease hook, and the bean hook, both made out of old scythe blades and used in reaping pease and beans, are peculiar to this Riding; and as was the linne burner's fork till lately. (*See fig. 547 b, c.*)

The moulting *slige* is a useful implement for levelling the small inequalities of meadow and pasture land, and spreading the dung dropped by the cattle. It is a frame of wood about five feet square (the sides of which are about four inches thick to give it weight and strength), having three bars of iron fixed to the lower side, the points of which are thinned to sharp edges. When in use, some thorns are drawn under the hinder wooden bar, and above the middle one, to which they are fixed by cords. It is wanted to be removed from one field to another, it is turned the other side up, which preserves the edges of the bars from injury. It is drawn by two horses, and will go over a great extent of land in a day.

### 6. Enclosing.

The taste for this has been carried too far, and land enclosed which has not and probably never will repay the expense.

### 7. Arable Land.

Two-thirds of the wolds and one-third of the rest of the Riding under the plough; fallow, wheat, oats; or fallow, barley, beans, common rotations.

### 8. Grass.

The marshy meadows adjoining the Derwent, a few grazing pastures in Holderness and Howdenshire, and the small garths or paddocks in the immediate vicinity of the towns and villages, form the principal part of natural grass lands.

The *sal maritima* on the outside of the embankments are of no great extent. Unless the mud is so elevated as to be constantly above water for a few days at neap tides, no plants take possession of the surface; but when vegetation can go on, the first plant which takes possession is the *salicornia* or samphire, and next the *poa maritima*, which in a short time covers the surface with a close short sward. A few sheep are occasionally put on it when not too much dirtied by the mud of the spring tides.

In laying land to grass caraway and parsley sown among it by some, to preserve the health of the sheep.

### 9. Gardens and Orchards.

Almost unknown, excepting among the higher classes; farmers rarely use any other vegetable than potatoes and turnips; cottagers cultivate their gardens with more care than the farmers.

### 10. Woodlands.

Of no great extent in proportion to the Riding; extensive plantations made on the wolds.

### 11. Improvements.

Holderness drains an extensive work of the kind on the east side of the river Hull; it extends over nearly 12,000 acres, and is managed by commissioners. Various other extensive drainages.

### 12. Live Stock.

Holderness cattle, remarkable for their large size and abundant supply of milk, prevail universally. This breed is supposed to have been introduced from Holland about a century ago, and improved by attentive management. The late Sir George Strickland the greatest modern breeder in the district. Breeding a principal object in most parts of the Riding, and feeding in Holderness when the pastures are rich.

Sheep formerly the Holderness breed, resembling that of Lincolnshire and the Wold sheep; now the Leicester and various other breeds.

Horses for the coach and saddle, the grand branch of breeding in this Riding, and in many or more produced in proportion to its extent than in any other. But it is allowed by all that the breed has of late much degenerated, owing to the inattention of the farmers. About twenty years ago a cross of blood was introduced, by which, though good saddle horses were produced, the coach horse was lost. This error discovered, an opposite and still more pernicious one was produced by the introduction of heavy black stallions from Lincolnshire. These produced a mongrel breed which will not be got rid of for several generations. In breeding, some castrate the foal while sucking, and think it a preferable practice to that of the North Riding.

Rabbits. About twenty warrens, containing together probably 10,000 acres.

### 13. Political Economy.

Not more than 140 miles of turnpike road in the whole Riding; few of these good, and the cross roads and lanes very bad; manufactures few; white lead, glue, glass, iron-foundry, oil-mills, cordage, sailcloth, patent whalebone, brick, tile, pottery, &c. at Hull. White lead, and Spanish white for whitening prepared from chalk, at Hessel. Howden coarse canvas for nail bags; near Driffield spinning and weaving too: other manufactures near York. Several agricultural societies; one for books and implements at Howden.

**7023. DURHAM.** 582,400 acres of surface, in some places mountainous and in most places hilly; the soil in great part poor; the agriculture generally approaching the best model, that of Northumberland, and the county distinguished by the Durham or Teeswater breed of cattle, and by its lead and coal mines. The celebrated farmer and breeder, Culley, was a native of this county, and farmed here as well as in Northumberland. (*Granger's General View, 1794. Baily's General View, 1810. Marshal's Review, 1818. Smith's Geological Map, 1824.*)

### 1. Geographical State and Circumstances.

*Climate* fine and mild in the lower districts, but on Crossfell, the highest land in the county, being 3400 feet above the level of the sea, snow frequently lies from November till the

middle or end of June. General time of harvest from the beginning of September to the middle of October.

Soils principally clay loam and peat; the latter prevails in the western part of the county or lead mine district; there is a tract of calcareous soil in the interior of the county.



**Minerals:** coals found over a considerable portion of the county, workable to the extent of 100,000 acres; those in the northern parts of the county wrought for exportation, in the western and southern parts for land sale only. In various parts of the coal districts are dykes or fractures, (fig 796, a, b,) and consequent derangement of the strata, which throw the beds of coal on one side of the dyke of many feet up or down. The fissure between being commonly filled with clay, stops the water in its course along the different bed (d, e) intercepts the drainage, and greatly damages the working of the coal.

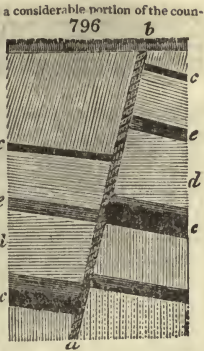

**Lead mines** numerous in the western district; the ore mostly in vertical fissures of limestone and other rocks like the dykes.

**Milstones, grindstones, freestones, slates** of grey or freestone kind, silver sand, limestone, whinstone, claystone or black metal stone, and yellow ochre, also found.

**Water.** Salmon fishery on the Tyne has greatly declined, owing to the building of weirs, which prevent their getting up. Bailey remarks, that if dams of this description were put across the river Tweed, a revenue of nearly 16,000*l.* per year, received for rents of fishings, and 60,000*l.* a year the value of the fish taken in that river, would be reduced to a mere trifle, in a few years.

**Salt springs,** from which salt is made near Britt and other places. A spa or salt sulphur spring near Durham, and another on J. G. Lambton's estate, with public baths and dressing rooms. Various others of less note.

**2. Property.**

Largest estates, 20,000*l.* to 22,000*l.* a year; several from 1000*l.* to 3000*l.* from which they descend by regular gradations to the smallest sums. Some estates let by proposal, but the general mode is to ask a rent, and treat with tenants six or seven months before the existing leases expire.

**3. Buildings.**

Generally of stone and slate; cottages of one story, covered with thatch or tiles.

**4. Occupation.**

Largest farm about 1000 acres, greatest number from 150 to 50 acres. The larger farmers, almost only those who have made improvements; among these, Messrs. Culley and Charge first led the way, and have been followed by Messrs. Collings, Mason, Taylor, Trotter, Nesham, Seymour, and many others, by whose exertions and judicious selection of stock this district will be lastingly benefited.

Greatest number of small laboring farmers greater slaves than their servants, being generally employed through the summer, in some kind of work or other, from four o'clock in the morning till eight at night; and in every other season of the year from twilight to twilight; and may truly be said, "to rise early, take rest late, and eat the bread of carefulness."

**Leases,** three, five, and seven acres, excepting church and corporation leases for 21 years, and lives. Those farms let for short terms remain stationary, as no prudent man will lay out his money in improvements, for which, when completed, he will be rewarded by an advance of rent, proportioned to the improvement he has made.

**5. Implements.**

Swing ploughs of the Rotheram kind; of late the Smalls

plough; various other good implements, and in many parts now (1823) the improved forms of Northumberland and Berwickshire.

**6. Enclosing.**

On dry soils hedges are frequently planted on a raised mound, forty inches broad, and the height twelve inches; a small ditch is cut on each side to make it, and the quicks are planted in the middle. In this mode the land may be ploughed nearly to the mound, and when the thorns are grown to a sufficient height, almost close to the hedge. When they are five or six years old, every other stem is cut clean off; within two or three inches of the surface, and the remaining ones stripped of their principal branches; then stakes of thin stipes high are driven in at proper distance, and the splashing stems, having a slight cut on one side to make them bend easier, are wound amongst the stakes at an angle of about twenty-five degrees, and a single elder is wound round the top to keep the stakes tight.

**7. Arable Lands.**

Ploughing generally well executed, but in some places the subsoil prevents sufficient depth of furrow, i.e. six inches. The turnip culture, rotations, and general management of arable land, the same as in Northumberland; that is of the most improved kind; seventeen tons of ruta baga are equal to thirty-one tons of white turnip in feeding cattle or sheep.

**Mustard** was formerly much grown in this county, and Durham mustard was proverbial for its excellence. At present a crop of mustard is rarely met with. It is generally sown upon pared and burned land in April, one pound per acre. The produce about twenty bushels per acre; and price from eight to sixteen shillings per bushel.

**Potatoes** in the village of Hamstely have been the principal article of trade, and the principal employment of several families for eighty years; they are very particular in having good sets, each with two eyes; use reddish or pink sorts, plant in March and April, and both horse and hand-hoe; no curl appears among them, but some times they turn wild, or tend to that state, producing more flowers than usual, and continuing flowering much later, sometimes till Michaelmas, and producing few tubers and slender stems. Whenever this is observed, the tubers of such potatoes are no longer used for propagation.

**8. Grass.**

Not much old surface, which there is chiefly upland.

**9. Woods and Plantations.**

Scampston elm, from a place of that name in Yorkshire, but supposed originally from America, will make shoots from grafts, in one year, of 5 or 6 feet; introduced in young plantations by Messrs. Falla, eminent nursery men of Gateshead; vale of Derwent well wooded; Sir J. Eden a great planter.

**10. Embankments.**

Begun on the Tees in 1740, and about 1500 acres secured between that period and 1800.

**11. Live Stock.**

Short horned cattle. The famous Durham ox, bred by Charles Colling of Kellan in 1796.

**Sheep.** Teeswater and Leicester breed; stock bred, reared and fed in the most scientific manner, especially by the larger farmers mentioned above (4).

**12. Political Economy.**

Turnpike roads first made in 1742; materials, whinstone, limestone, river gravel, and freestone. Roads excellent where materials are broken sufficiently small; they are also in good repair. Milestones on some roads, hollow triangular prisms of cast-iron, with projecting letters and figures. They are two and a half feet high, and fixed on an oak post, four and a half feet long, sunk two and a half feet in the earth. Guide posts much wanting. No iron railways, and no public roads or canals.

**Manufactures.** Wrought iron foundries, glass-houses, potteries, salt, copperas, sal ammoniac, coal tar, paper, woolen, cotton, and linen cloth. Several agricultural societies; the first established at Darlington in 1785.

**7024. NORTHUMBERLAND,** including those detached parts of the county of Durham, called Norhamshire, Islandshire, and Beddingtoushire, comprehends a surface of 1,267,200 acres, chiefly mountainous or breeding districts, but including 450,000 acres proper for tillage. The celebrity of this county both for its tillage and breeding is well known. Here turnips were first extensively cultivated in the drill manner, and the best principles of breeding practised by Culley. To this gentleman and Bailey agriculture owes much: the latter was perhaps one of the most enlightened and accomplished of modern agriculturists. (Bailey and Culley's General View, 1805. Matshal's Review, 1808. Smith's Geological Map, 1824.)

**1. Geographical State and Circumstances.**

**Climate** subject to great variation of temperature; snow to a considerable depth on the mountains, when there is none in the lower districts; weather runs in extremes; very cold in spring, and seldom mild before June.

**Soil and Surface.** Strong fertile loam along the coast; sandy, gravelly, and dry loam on the Tyne, from Newbourn to Halsburgh, on the Coast to Rothbury; on the Aln, from Alnwick to the sea; down Tweedside, but chiefly in the vales of Breamish Hill and Beaumont. The hills surrounding the Cheviot mountains are mostly a dry sharp gravelly loam. Moist loam occupies a large portion of the county, unsafe for sheep, and unfit for turnips, and peat earth prevails in the mountainous districts.

**The aspect of the surface** is marked with great variety; along the sea coast it is nearly level; towards the middle more diversified, and thrown into large swelling ridges, formed by the principal rivers. These parts are well enclosed; in some places enriched with wood and recent plantations, but the general appearance is destitute of those ornaments. The western part (except a few intervening vales) is an extensive scene of open mountainous districts, where the hand of cultivation is rarely to be traced. Of the mountainous districts, those around Cheviot are the most valuable, being in general fine green hills, thrown into numberless variety of forms, enclosing and sheltering many deep, narrow, and sequestered glens.

**Minerals.** Coal in abundance in the greatest part of the county; it is like that of Durham of the caking kind, and is found in the south-east quarter of the best quality; quantity exported, chiefly for the London market, 956,250 London

chalders. Calculated that the whole coal of the counties of Newcastle and Durham will be exhausted in 550 years. Limestone, stone-marl, clay-marl, lead-ore, and ore of zinc in small quantities; freestone, whinstone, and iron are all worked.

**Water.** The Tyne and Tweed have been long celebrated for their salmon fisheries; in the latter a rent of 800*l.* a year is paid for a fishing of two hundred yards in length, near the mouth of the river; and the same rent is paid for each of two other fishings above the bridge; but more than two hundred and fifty yards in length each. The fish taken here, are the salmon, bull-trout, whiting, and large common trout, and nearly the whole of them sent to London; in the conveyance of which, a great improvement has taken place of late years, by packing them in pounded ice; by this means they are presented nearly as fresh at the London market, as when taken out of the river. For the purpose of drying them, and keeping up a constant and regular supply, vessels called smackys sail three times a week, and being purposely constructed for swift sailing, frequently make their run in forty-eight hours. These vessels are from 70 to 120 tons burthen; on an average twelve men are employed in each vessel, and make about fourteen voyages in a year; and not less than 75 boats and 300 fishermen are employed in taking the fish in the River Tweed.

**2. Property.**

One estate upwards of 40,000 acres, the rest vary from 20 to 20,000; small estates rare in the northern part of the county. Few counties in which estates have been so rapidly improved; several instances of the value trebled in forty years; principal cause letting large farms on twenty-one years

leases. Usual mode of letting farms, is to fix a rent six or twelve months before the expiration of the lease; but upon one of the largest estates in the county (the Earl of Tankerville's), the tenants have an offer of their farms two years and a half, or three years before the expiration of the lease, which is a mutual benefit to both landlord and tenant, and is attended with so many advantages, that it is in a fair way of being generally adopted.

### 3. Buildings.

Farmhouses formerly very shabby and ill contrived, now totally different. The most approved form of distributing the various offices is, on the east, west, and north sides of a rectangular parallelogram, (fig. 797.) which is generally divided into two fold-yards for cattle of different ages, the south being left open to admit the sun; and for the same reason, and also for the sake of cleanliness and health, the farm-house (a) is removed in front thirty or forty yards; between which and the south wall of the fold is a small court for coals and young poultry; the barn (b), is 18 feet by 60, with threshing machine driven by horses, water, wind, or steam; on each side are sheds (c c), over which are granaries; beyond these, as wings to the main square, are sheds (d d), upon which are built corn stacks, and the house traversed by the wintering yearling calves, the other for holding implements of the larger kind. On the east of the main square is the stable (e), and in the west a house for cows and fattening oxen (f), each 16 feet by 48 feet. Over the pig sties (g), are poultry houses which open into the court-yard of the house, as the piggeries do into the fold-yards for wintering young cattle (h h).

Cottages of stone and lime and tiled; floor of lime and sand; the living room fifteen feet by sixteen, and the cow-house nine feet by sixteen.

### 4. Occupation.

Farms generally large in the north, some from 2000. to 40000. a-year; in various parts farms from 500. to 1000., and from 1000. to 10000. a year. The capital necessary for such farms, entitles the farmers to a good education, and gives them a spirit of independence and enterprise, that is rarely found amongst the occupiers of small farms and short leases. Their minds being open to conviction, they are ready to try new experiments, and adopt every beneficial improvement that can be learnt in other districts; for this purpose, the farmer is conversed the most distant parts of the kingdom to obtain agricultural knowledge, and have transplanted every practice they thought superior to those they were acquainted with, or that could be advantageously pursued in their own situation; and scarcely a year passes without some of them making extensive agricultural tours, for the sole purpose of examining the modes of culture, of purchasing or hiring the most improved breeds of stock, and seeing the operations of new invented and more useful implements.

### 5. Implements.

Of the most approved kind; and some of these, as the plough, drill, horse hoe, &c. owe their chief merits to the Improvements of Bailey. A pair of pruning shears recommended as preferable to those in common use for cutting hedges. They consist of a strong sharp knife, six inches long, moving betwixt two square edged chaps; the upper handle is two feet six inches long, and the other two feet three inches. (See *Encyclopædia of Gardening*, 1334. fig. 124.)

### 6. Enclosures.

Size of fields varies with the size of the farms; in some parts from two to six or eight acres; in the northern parts, where the farms are large, from 20 to 100 acres. The quicks should never be planted nearer each other than nine inches, and, upon good land, a foot. Quicks four or five years old, with strong clean stems, are always to be preferred to those that are younger and smaller. It is a custom in some parts to clip young quicks every year: this makes the fence look neat and strong, but it checks the growth, and the stems are always weak in the stem, and, when they grow old, open at bottom; while those that are left to nature, get strong stems and side branches, which, by interweaving one with another, make a thick and impenetrable hedge, and if cut at proper intervals (of nine or ten years), will always maintain its superiority over those that have been clipped from their first planting. In point of profit, and of labor saved, there is no comparison; and for beauty, we prefer the neat and thick luxuriant hedges, in full bloom, or laden with its ripened fruit, is a more pleasing, enlivening, and gratifying object, than the stiff, formal sameness produced by the shears.

### 7. Arable Land.

Trench ploughing practised by a few in breaking up grasslands. About 1795, when horses were scarce and dear, a good many oxen were used for ploughing and carting about the farm, but after a few years trial, they were given up; they were harnessed both with yokes and collars, and only ploughed half a day at a time.

Fallowing on all soils once in three or four years, was general through the county, till the introduction of turnips. On soils improper for this root, the naked fallow still prevails; but the quantity of fallow probably on all soils will, after a long series of good culture, become less necessary, and may in many cases be finally dispensed with.

Turnips were first grown in the northern parts of the county about 1753. Proctor, the proprietor of Roch, brought Andrew Willey, a gardener, to cultivate turnips at Roch, for the purpose of feeding cattle; that Willey afterwards settled at Lesbury, as a gardener, and was employed for many years to sow turnips for all the neighborhood; and his business this way was so great, he was obliged to ride and sow, that he might dispatch the greater quantity.

Hoing turnips was introduced at the same time, and at first practised by gardeners, and other men, at extravagant wages. Idleston, about thirty years since, had the merit of first reducing the price of hoing, by teaching boys, girls, and women to perform the work equally as well, if not better than men. The mode he took was simple and ingenious: by a light plough,

without a mould-board, he divided the field into small squares of equal magnitude, and directed the boys and girls to leave a certain number of plants in each square. In a short time they became accurate, regular, and expert hoers; and, in a few years, all the turnips in the county were hoed by women and boys, at half the expense, and better than by men.

797

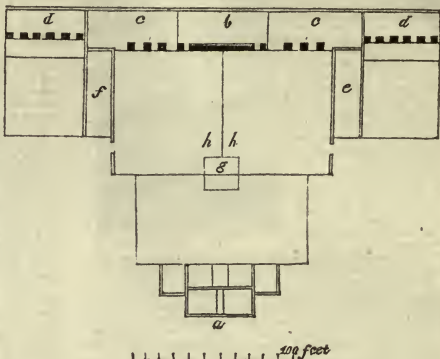

The broadcast culture of turnips, in the northern parts of the county, was not inferior to any we ever saw; and in respect to accurate, regular, clean hoeing, superior to what we ever observed in Norfolk, Suffolk, or other turnip districts which we have frequently examined. (Bailey.)

Drilling turnips was first introduced to the county about 1780. Drilling this, as well as other crops, evidently originated with Tull, whose first work, *Specimen of a work on Horse-hoeing Husbandry*, appeared in 1751. It appears that Craig, of Arbigland, in Dumfriesshire, began to drill turnips about 1745; and next we find Philip Howard, of Corby, drilling in 1755; and Pringle drilling "from hints taken from Tull's book," in 1756 or 1757. William Dawson, who was well acquainted with the turnip culture in England, having been purposely sent to reside in those districts for six or seven years, where the best cultivation was pursued, with an intention, not only of seeing but of making himself master of the manual operations, and of every minutiae in the practice, was convinced of the superiority of Pringle's mode over every other he had seen, either in Norfolk or elsewhere; and in 1762, when he entered to Frogmore farm, near Kello, in Roxburghshire, he immediately adopted the practice upon a large scale, to the amount of 100 acres yearly. Though none of Pringle's neighbors followed the example, yet, no sooner did Dawson, an actual or rent-paying farmer, adopt the same system, than it was immediately followed, not only by several farmers in his vicinity, but by those very farmers adjoining Pringle, whose crops they had seen, for ten or twelve years, so much superior to their own: the practice in a few years became general.

### 8. Grass.

Not much old grass in the county.

### 9. Woods.

Not very numerous, though a considerable demand for small wood by the proprietors of the collieries and lead mines. Artificial plantations rising in every part of the county.

### 10. Improvements.

Embanking and irrigation practised in a few places which require or admit of these operations.

### 11. Live Stock.

Cattle the short horned, long horned, Devonshire, and wild cattle.

Sheep, the Cheviot, heath, and long woolled. The modern maxims of breeding were introduced into the county by one of Bakewell's first disciples, Culley, of South Durham, well known for his work on Live Stock, previous to which, "big bones" and "large size" were looked upon as the principal criterion of excellence; and a sacred adherence to the rule of never breeding within the canonical degree of relationship; but those prejudices are at this period, in a great measure done away; and the principal farmers of this district may now be classed amongst the most scientific breeders in the kingdom, who have pursued it with an ardent and unremitting attention that have not failed of success.

Horses for draught brought from Clydesdale.

Goats are kept in small numbers on many parts of the Cheviot hills, not so much as an object of profit, but the shepherd asserts, that the sheep flocks are healthier where a few goats do pasture. This probably may be the case, as it is well known that goats eat some plants with impunity, that are deadly poison to other kinds of domestic animals. The chief profit made of these goats is, from their milk being sold to invalids, who come to Wooler in the summer season.

### 12. Political Economy.

Roads of whin or limestone, and mostly good. Manufactures, gloves at Hexham, plait straw for cottagers' and laborers' hats, and also for those of the higher classes. Woollens in a few places; and a variety of works connected with the coal trade and mines at Newcastle. No agricultural societies, these Bailey holds in little estimation; but thinks if public farms were established in each county, and supported by a rate on the income of its proprietors, they would be the most effectual means of promoting agricultural improvement.

7025. CUMBERLAND. 970,240 acres of mountainous district, remarkable for its picturesque beauty, and also of late greatly improved in its agriculture. The exertions of the late Bishop of Llandaff in planting, and of J. C. Curwen, Esq. in field culture, have contributed much to the improvement of this county, which, as far as its soil and climate permit, may be considered as on a par with Northumberland. (*General View*, by J. Bailey, and G. Calley, 1804. *Marshal's Review*, 1808. *Smith's Geological Map*, 1824.)

### 1. Introductory Observations.

Pringle informs us that "trees and plants, being altogether passive, accommodate themselves very slowly to a change of climate; but the idea has been already thrown out, that even those of the torrid zone may be made to flourish in the northern regions; it may be even gradually inured to the climate; that the climate itself may be changed for the better; and that some thousands of years hence, reposing under their own olive trees, future Britons may quaff their own wine, or sip their own tea, sweetened with the juice of their own sugar-cane."

Pringle "found it impossible" not to mention to the Board that he was remarkably well treated when he surveyed the county, which "filled him with peculiar feelings of pleasure and respect." Some of those feelings he voids on Sir John Sinclair, in the following terms, "What gratitude is due to him (!) who first called the attention of the nation to its most important interests, and whose unremitting efforts are directed to promote the good of his country! How well does he deserve, and what a sure road has he chosen to immortal fame, that will survive the ravages of time, and smile at the fleeting celebrity of martial achievements!" "This," Marshal "observes, most assuredly means, not him, but me."

In some preliminary observations to this report by the Bishop of Llandaff, are suggestions for settling poor people in cottages on the wastes, as has been done in Spain, and on the advantages which would result from planting them, especially with the larch and oak.

### 2. Geographical State and Circumstances.

*Climate.* Healthy, though subject to great and frequent falls of rain, especially in autumn, which renders harvest late and precarious; snow on the mountains for six or eight months. Average rain at Keswick seventy inches.

*Soil.* Clays and loams on the better parts of the valleys and hill sides, and peat earth on the mountainous districts.

*Surface.* Beautifully and greatly diversified, chiefly mountainous, and incapable of being improved by the plough; but part of the valleys and plains are cultivatable soils.

*Minerals.* Chiefly coal, lime, and lead ore; there are also black lead, copper, gypsum, lapis calaminaris, and excellent slate and freestone.

7026. WESTMORELAND. 450,722 acres, chiefly of mountain and moor, but with some few tracts of vale lands, cultivated or capable of cultivation. On the whole it is naturally the most unfavorable county to agriculture or comfortable living in England, owing to its wet and cold climate, ungrateful soil and rugged surface. (*Pringle's General View*, 1794. *Marshal's Rev.* 1808. *Smith's Geological Map*, 1824.)

### 1. Geographical State and Circumstances.

*Climate.* S.W. winds and rains prevail for eight months in the year; in 1792 eighty-three inches, medium forty-five or fifty inches, which is twenty inches above the medium quantity that falls in Europe. Air pure and healthy; winters long and severe. In 1791-2 thirty-six pounds were paid for cutting in the snow ten miles of horse tract between Sharp and Kendal.

The soil most prevalent on the low lands is a dry gravelly mould, and peat on the mountains.

*Surface.* Mountainous and hilly, and in most places incapable of cultivation by the plough.

*Minerals.* Some trifling veins of lead; limestone in abundance in most parts of the county; excellent blue slates; gypsum used for laying floors; freestone; and marble near Kendal.

*Water.* Several rivers and some lakes, corresponding in beauty and products with those of Cumberland.

### 2. Property.

As in Cumberland; land-owners called statesmen, (for estatesmen) as in Ireland.

7027. LANCASHIRE. 1,150,000 acres. included in a very irregular outline, extending above a degree, or about seventy-four miles from north to south, containing mountainous and moory surface, and a large portion of low, flat, or moderately varied lands, of good quality. The soil in great part sandy, and chiefly in pasture. The early introduction and successful culture of the potatoe, distinguishes this county, and also the immense extent of its cotton manufactures, and very considerable foreign commerce from Liverpool. It is also the country of Brindley, the engineer. (*Holt's General View*, 1795. *Dickson's General View*, prepared by Stevenson, 1815. *Marshal's Review*, 1808.)

### 1. Geographical State and Circumstances.

*Climate.* Air every where pure and salubrious, but on the elevated parts cold and sharp; protected, however, by the northern and eastern ranges of mountains from the N. and E. winds; not much snow or long continued severe frosts. In 1819-20, when the thermometer in gardens near London had fallen ten degrees below *Zero*, that in the botanic garden at Liverpool never fell to *Zero*. Average of rain in the county, probably about forty-two inches; in 1792, sixty-five; and in some years fifty. From a register of the times during a series of years, at which potatoes, asparagus, and gooseberries were first brought to the Liverpool market, it appears that the difference between an early and late spring is not less than six weeks.

*Soil.* On the mountains and moors rocky and peaty; on the northern part of the lowlands moist, cold, and rushy silt; on the rest chiefly sandy loam.

*Minerals.* Principally coal, copper, lead, and iron; the first and last very abundant; there is also slate, grey-slate, and flagstones, freestone, and limestone.

*Waters.* Seventy-five miles and upwards of sea-coast, and several rivers and meres.

### 2. Property.

Very variously divided; a considerable number of yeomanry from 10*l.* to 700*l.* per annum; a general spirit for possessing land and agricultural improvement; tenures, as usual, chiefly freehold.

*Waters.* Sixty-seven miles of sea-coast, several large and small rivers, and the lakes well known for their beauty, and the excellent charr, trout, and other fish which some of them produce.

### 3. Property.

Few counties where land is in such small parcels, and these occupied by their owners. The annual value of these tenements vary from 1*l.* to 50*l.* a year; generally from 15*l.* to 30*l.*, some few 100*l.* Largest estate in the county 13,000*l.* a year. Tenure of by far the greater part of the county "customary tenure," a species of vassalage, by which the holder is subject to fines, heriots, and various services to the lords of manors. A good deal has been enfranchized. Copyhold and leasehold are rarely met with; what is not customary is freehold.

### 4. Buildings, Implements, Arable Land, &c.

Approaching to that of Northumberland. A great many young plantations rising on the sides of the mountains.

### 5. Live Stock.

Cattle of various kinds; breed of the county a small long horned kind; but the most improved varieties are now introduced.

Sheep bred in the county the Herdwicks, a hardy mountain sheep. Some horses bred by the farmer, and bees very common. In every parish the taking of moles is let at a certain sum, and defrayed by a parochial rate per acre; a plan which will soon eradicate this animal from the county.

### 6. Improvements.

Various kinds, as draining, watering, planting, &c. made by Watson, Bishop of Llandaff; at Colgarth Park. Those of J. C. Curwen, Esq., of Workington, especially in feeding and fattening stock, have made a distinguished figure in the agricultural world since the publication of this report. Curwen's system, may be considered as the father of the soiling and teamed food feeding in England. In spite of a most ungrateful soil, and cold rainy climate, he manages to keep an extensive farm in the very best order, and what is rare amongst gentlemen who are cultivators, to cultivate with profit. He is a warm friend to agricultural merit in every shape, and one of the best hearted of men.

### 3. Buildings.

Very indifferent; few mere cottages; the laborer and mechanic generally reside in a small farm-house, and occupy more or less land.

### 4. Occupation.

Farms small, and farmers, who are generally proprietors, "live poorly and labor hard," in the fields in summer, and weaving in winter; wear clogs, the upper part of leather, and the soles of birch, alder, or sycamore. The culture of arable land is very limited, and, like that of grassland, was in a very backward state at the time the reporter wrote, but gradually improving. Dairying in a small way is generally practised, but little attention to the sort of cow or breeding. The Earl of Lonsdale and Bishop of Llandaff have set the example as to planting.

### 5. Manufactures.

Woolen cloth or Kendal coatings, stockings, silk, gunpowder, &c. A private carpet manufactory at Lowther, by the Earl of Lonsdale.

### 3. Buildings.

Old farmhouses the work of chance and random; houses often there, formerly occupied by proprietors, and offices without order or design, but various new erections on the most approved plans; cottages in many places comfortable, with good gardens, especially those occupied by operative manufacturers and mechanics. Those in the less improved parts of wattle-studd work, plastered or wrought in with tempered clay and straw; provincially "cat and clay."

### 4. Occupation.

Farms in general small; education and knowledge of most of the small occupiers very circumscribed; larger farmers more enlightened, and having more command of capital, are improving the culture of their farms.

### 5. Implements.

Little improvement, but the Northumberland plough and Meikle's threshing machine introduced; horse patterns are almost peculiar to this county, and are used in cultivating light peaty soils.

### 7. Arable Land.

Less prevalent than grass; but great attention paid to the culture of potatoes, both by farmers and cottagers; the former generally cultivate in drills, and horse hoed; the latter in beds or dibbled in rows, and hand hoed. The method of growing early potatoes, and several crops on the same soil in one season has already been given. (4851.) Onions are cultivated exten-

sively near Warrington, and rhubarb and madder have been tried, and grown to very great perfection, but not so easily dried and prepared for sale, as to induce a continuance of the practice.

#### 7. Grass Lands.

Extensive, but chiefly coarse upland pastures: some good meadows and productive marsh lands. Application chiefly the dairy for home consumption of milk and butter; not much cheese made, excepting on the Cheshire side of the county.

#### 8. Gardens and Orchards.

Excellent market gardens near most of the large towns. Liverpool remarkably well supplied: great quantities of cabbages and onions used by the shipping, and of dried herbs and onions exported; the dried herbs sent to Africa. "There is a certain farm in Kirkby, about eight miles north-west from Liverpool, the soil a small part of which is a black loamy sand, and which produces great quantities of early and strong asparagus, and another farm, a part of which is of the same nature at a place called Orrel, about four miles north-west of Liverpool: both which produce this plant with less attention and less dung than requisite in the rich vale of Kirkdale, about two miles from Liverpool, where the greatest quantity of land in any place of this neighborhood is appropriated solely to horticulture."

*Gardens of Mechanics.* "A small patch of ground appended to his cottage, furnishes the weaver, smith, or carpenter with health and pleasure, and contributes to his sobriety; intemperance not unfrequently proceeding from want of recreation to fill up a vacant hour. This small space is devoted to nurturing his young seedlings, trimming his more matured plants, contemplating new varieties, in expectation of honors through the medium of promised premiums. Thus, starting at intervals from his more toilsome labors, the mechanic finds his stagnating fluids put in motion, and his lungs refreshed with the fragrant breeze, whilst he has been thus raising new flowers of the auricula, carnation, polyanthus, or pink, of the most approved qualities in their several kinds; and which, after being raised here, have been dispersed over the whole kingdom. But not only flowers, but fruit have been the objects of their attention. The best gooseberries now under cultivation had their origin in the county of Lancaster; and, to promote this spirit, meetings are annually appointed at different places, at which are public exhibitions of different kinds of flowers and fruits, and premiums adjudged. These meetings are encouraged by master tradesmen and gentlemen of the county as tending to promote a spirit which may be expected to be converted into a more important channel. Those little societies for promoting the improved culture of the gooseberry prevail most in the southern parts of the county. They have unquestionably had much influence in bringing the different sorts of this fruit, and the currant, as well as some others, to their present state of improvement. The gooseberry both of the red and white kind, is now in most places grown to a very considerable size, in some situations as large as a pigeon's egg. This is chiefly effected by keeping the plants much cut in their branches, and having well rotted rich manure applied frequently about their roots, the land being kept perfectly clear about them. The annual publications, called *The Manchester Gooseberry-book*, and *The Manchester Flower-book*, contain the names of the principal societies, and of the prizes awarded each year, and a variety of other information." *Dickson*, p. 428.

7028. CHESHIRE. 665,600 acres of verdant surface, exclusive of upwards of 10,000 acres of naked sands in the estuary of the river Dee. It is one of the most productive grass land districts in the kingdom, the grass retaining its growth and verdure, in a great degree, during the whole year, owing to the moisture and mildness of the climate. The department of husbandry in which it excels is cheese making, and it is also noted for its salt works from brine springs and rock. (*Medges' General View*, 1794. *Holland's General View*, 1806. *Marshal's Review*, 1809.)

#### 1. Geographical State and Circumstances.

*Climate* supposed the most rainy in the kingdom. *General surface* an extensive plain, apparently a levelly covered country. Barren hills on the eastern margin of the county.

*Soils* chiefly clayey or sandy; clay prevails, but very generally the two earths blended together, producing clayey loam, and sandy loam.

*Subsoil* chiefly clay, or marl; but also rammel, foxbench, gravel, or red rock. Rammel is a composition of clay, sand, gravel, and oxide of iron; it is in strata of from eighteen to thirty inches, on white colored sand, or clay marl. Foxbench is iron ore or oxide, which crumbles to pieces when exposed to the air; but is hard and rocky when under the soil, and is more injurious to trees than rammel, as it cannot be penetrated by their roots.

*Minerals.* Fossil salt and coal both extensively worked. There is also copper, lead, and freestone, but very little limestone. Salt is dissolved and refined in the same manner as brine, and from beds of fossil salt. The former have been worked from time immemorial, and the latter from about 1670. By the operation of blasting, and the mechanical instruments usually employed in mining, the rock is obtained in masses of considerable size, differing in form and purity. The purer less pure is dissolved and refined in the same manner as brine.

*Water.* Several rivers and meres; the former are very muddy after rains, and not remarkable for their fish; but the latter abound in pike, bream, perch, dace, and eels.

#### 2. Property.

Few counties of equal extent with so many wealthy landowners. Fifty proprietors resident in the county, with estates of from three to 10,000*l.* a year, and as many from one to 3000*l.* "From the advantages which have been derived from trade, and from the effects of the increase of taxes, which have prevented a man living with the same degree of comfort on the same portion of land he could formerly, many of the old owners have been induced to sell their estates, and new proprietors have spread themselves over the country, very different in their habits and prejudices. It may be doubtful whether the change on the whole has been disadvantageous. Land, when transferred, is generally improved by its new possessor. With a view, and often a more enlightened view, of its advantages and resources, he brings with him the means and the disposition to try experiments, and give to his new acquisition its greatest

An orchard of sixty-four acres on the banks of the Irwell, near Manchester, and some others in sheltered places near the principal towns; but the prevailing west winds is much against their increase.

#### 9. Woods and Plantations.

A good deal of planting going forward in most parts of the county, but not much old timber or copse.

#### 10. Improvements.

Of moss bogs and marshes there is great extent, and we have already noticed the principal modes of improving them. (4153.)

A good deal of draining, paring and burning, and liming has been done, and also irrigation in several places. A good deal of low soil embankment along the northern part of the coast, especially at Rosshall, by Hesketh. It was proposed some years ago to embank Lancaster and Ulverstone sands, by which nearly 40,000 acres of sandy soil would have been gained at an expense of 150,000*l.* or according to some much less; but owing to the difficulty of getting the small proprietors of fisheries, and other trading interests to agree, the idea was dropped at the time, and not resumed. The proposed modes of procedure for this and other intended embankments, are given in the report. Boglands have been extensively cultivated by the celebrated Koscoe, of which some account has been already given. (4191.)

#### 11. Live Stock.

Cattle, the Lancashire or long horned, made the basis of Bakewell's improvements; a good many short horned also bred, when the dairy is the object. Larger grass farms near the popular towns, furnish milk; the smaller ones butter, and the remote farms cheese. 100 cows kept in Wakefield's dairy near Liverpool. Cheese made resortly both of Cheshire, and chiefly from the long horned, or native breed.

Sheep not very common in this district.

Horses very generally bred of the strong team kind, stout compact saddle horses, and middling size and bone for the stage and mail coaches.

#### 12. Political Economy.

Roads bad in most places, owing to the want of good materials, and the moist climate. In the coal tracts about Manchester, Bolton, and Wigan, the roads are all paved, as it was thought no other would stand the heavy traffic on them. These paved roads are said to be the most expensive, and most disagreeable of any; but they have here no other kind of material that will stand heavy cartage.

An ingenious road-maker in the neighborhood of Warrington, has of late exploded the common convex form, and adopted that of one inclined plane; the inclination just sufficient to throw off occasional water. The road between Worsley and Chowbeate, was made in this form, but it was found not to answer, as, though it threw off the water, high and heavy laden waggons were exposed to much danger of being overturned.

Various canals and iron railways; those of the Earl of Bridgewater, the most celebrated; but others of recent date more extensive. Many different manufactures; cotton in its different branches the most important; also, woolen, flax, iron, and, in short, almost as great a variety as in Derbyshire. Several agricultural societies; that of Manchester established in 1767.

value. He feels the want of comforts and conveniences, which custom had rendered familiar to a former occupier; he builds, drains, and plants; and, by his spirit and example, stimulates all around him to increased exertions.

#### 3. Buildings.

Many noble mansions, especially that of the Earl Grosvenor, at Eton.

*Farm buildings*, on the large dairy farms, in the middle of the county, extensive and convenient; in other places the reverse; and crowded in villages; old buildings of shed work, walled work, and covered with thatch; new of brick and slate. An excellent set of buildings (*fig.* 798.) has been erected at Bromfield, near Warrington, on the estate of Sir P. Warburton. "A gentle descent from the ground at the front of the house has afforded Beckett, the occupier of this farm, the opportunity of conveying from a pond (*a*) a small stream through the farm-yard, with which he irrigates the meadows below the buildings. The superior richness of vegetation in these meadows, after the abundant proof of the advantage which Beckett derives from availing himself of this assistance."

Beginning with the *dwelling-house* of this farmery, it contains an entrance and passage (1), house place (2), servants' dining-room (3), back parlor (4), dairy, with whey pans and sink stone (5), room for the cheese after it is taken out of the salt (6), milking-house and salting-room (7), stairs to cheese-room (8), parlor, with cellar under (9), parlour (10). The immediate appendages of the house chiefly connected with the dairy are ranged on three sides of the inner yard (11), and consist of a coal house (12), wash-house, with pigeon-house over it (13), pump (14), pipe to boiling pans (15), boiler for pig-meat (16), privy (17), place for ashes (18), privy (19), inner pig-cot (20), outer pig-cot (21), passage (22), inner pig-cot (23), outer pig-cot (24), inner pig-cot (25), outer pig-cot (26), passage (27), inner pig-cot (28), outer pig-cot (29).

The *farm-yard* consists of a court, containing a large duck-pond and dunghill, surrounded by a broad passage, and enclosed on the west, east, and south sides by buildings, the north side being the wall of the inner yard. These buildings consist of a cow-house (30), double cow-house (31), cow-house (32), milder-bin (33), pan-house (34), corn-bag (35), threshing floor (36), corn-bag (37), corn-bag (38), corn-bag (39), threshing-floor (40), corn-bag (41), cart-hovel, with granary above it (42), stable (43), stable, or calf-cot (44), calf-cot (45).

Cottages much the same as in other counties; improving with the age. All the intelligent persons whom Dr. Hoiland conversed with, have invariably found, that the attachment of a small portion of land to the cottage of the laborer has been the direct means of rendering his situation in life more comfortable and easy, and of inducing those habits of honest independ-

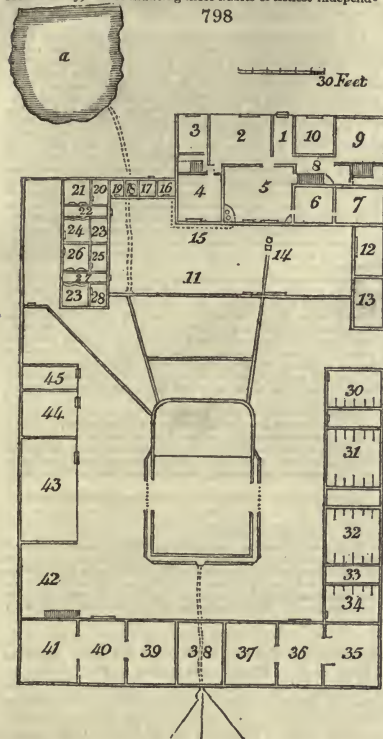

their habits, and, by consequence, in their ideas. Industry and excellent management of the dairy-women of this county much to be commended; leases generally for seven years.

5. Implements.

Rotheram plough and other good implements. A short strong scythe, with a blade twenty inches in length, and ruse in the middle, is used for scooping out the crowns of rough stools.

6. Arable Lands.

In small proportion to the pastures. Cabbages a good deal cultivated for cattle. Carrots near Altringham for the Manchester market, and also seed for the London seedsmen: Onions also for the Lancashire markets. The soil about Altringham dry and loamy; the carrots large, coarse, and fit only for horses and cattle.

7. Grass.

Natural meadows numerous, rich, and fertile. They are situated on rivers, which, from the frequency of heavy rains, overflow and enrich them. Extent of upland pasture very considerable; that on a tolerably stiff clay soil, especially with a substratum of marl, is reckoned the best for the dairy; more milk may be had from cows pastured on a rich loamy soil, but it is esteemed inferior in point of quality. Many farmers complain that their land is too rich for the dairy, by which the adhesive properties of the cheese is diminished; feeding of cattle little practised.

8. Gardens and Orchards.

Good gardens to most of the farm-houses. "All the varieties of raspberries, currants, strawberries, and gooseberries, are to be met with in the farm and cottage gardens in Cheshire. The culture of the latter fruit has been particularly attended to of late years; and there are several meetings in different parts of the county, where small premiums are adjudged to those who produce, out of their own gardens, gooseberries of the greatest weight. The common fruit trees, such as the apple, pear, cherry, and plum, are likewise grown in almost every garden. Of the latter kind, the damascene plum is by much the most common; and is an article of considerable profit to the cottager.

Orchards not numerous, and rather on the decline.

9. Woods and Plantations.

Few of large extent, yet the quantity of timber very greatly exceeds what would be a fair average for the kingdom at large. In the northern and middle parts the number of trees in the hedgerows and coppices is so considerable, that, from some points of view, the whole county has the appearance of an extensive forest. The most considerable ancient woods in the Earl of Stamford's park at Durham Massey. Few spots can boast such an assemblage of stately oaks, elms, and beeches. During a storm of wind, on the 21st of January, 1802, several hundred trees were torn up by the roots. One of these, when barked, contained 405 feet of timber, and was sold at six shillings and sixpence per foot, to the extent of 373½ feet. An elm blown down at the same time measured 146 feet. A colony of ferns had for ages fixed their residence on the summits of these trees, but on one of them being torn up, they were treated to a neighboring grove of beeches, where they have ever since enjoyed a secure abode.

A plantation of 1000 acres at Taxall, F. Jodrell, Esq.; it was planted by White, the landscape gardener, of Woodlands, Durham, at five pounds per acre, half the trees to be firs. Extensive plantations by Ashton, on Delamare forest.

Whitely, an ingenious tanner; at Ashley, near Knutsford, made some experiments a few years ago with the twigs and ends of the boughs of oak, as a substitute for the bark. These ground down, and used in the same way as the bark, manifested strongly astringent properties; but the necessity there was found to be for their immediate application, took away very greatly from their value; and their use is now almost entirely discontinued, though the plan at that time was adopted by several other tanners.

10. Improvements.

Drainage a good deal practised, especially with bricks and stones. Faring and burning, marling, sanding, claying, and liming, also practised to different degrees of extent. Sand of advantage chiefly by altering the texture of the soil, as that used contains no calcareous matter.

11. Live Stock.

Present stock of dairy cows a mixture of the long and short horned, the Derbyshire, Shropshire, Staffordshire, Welsh, Irish, Scotch, and New Leicestershire cattle. Those cows reckoned best which are bred on the farm. Calves reared from the best milkers, and at two years old put to the bull. Cows housed about the middle of November; permitted to dry ten weeks before their time of calving; usual dry foods, wheat, barley, and oat straw, hay, and crushed oats. The two former kinds of straw are found to make cows go dry much sooner than the latter; and another generally allowed effect attributed to such straw, that more than the usual time will be required to clean the cream of cows when fed; but without straw it seemed much more wholesome than barley straw, as having less of those effects attending it. Three or four weeks before calving, hay given; and from calving to turning to grass, some ground or crushed oats twice a day. The cows are turned into an outlet (a bare pasture field near the buildings) about ten o'clock in the morning, and housed again about four in the afternoon the winter through; or earlier if they showed an inclination to return; but they have no fodder in the outlet. Turning the cows out to grass in good condition is a matter much attended to, in order that they may, as the term is, "start well;" for if a cow is not in good condition when turned out to grass, or has been too much cried with barley straw, it is a long time before she gets into full milk.

The ox-cabbage and Swedish turnip are the kinds of green food most esteemed and cultivated in Cheshire. The former is usually put to the cows when the after-grass is consumed; it is sometimes given in the spring to cows that have newly calved. The large sugar-loaf cabbage has been occasionally used, when the pastures begin to fail and the after-grass is not ready; a circumstance which frequently happens, especially in dry weather. Turnips are given to the cattle in the winter, while they are feeding on straw; and as, at this time, no cheese is made, any objection to their use, from the flavor they give to the milk, is of little consequence. The reporter made inquiries from several farmers, with a view of ascertain-

ance, of temperance, and of industry, which are most efficacious in promoting the happiness of individuals, and, consequently, the general interests of society.

Lord Penrhyn's poultry-house, at Winghamton, are supposed the most magnificent that have ever been built. They are united in a building which consists of a handsome regular front, extending about 140 feet: at each extremity is a neat pavilion, with a large arched window. These pavilions are united to the centre of the design by a colonnade of small cast-iron pillars, painted white, which support a cornice and a slate roof, covering a paved walk and a variety of different conveniences for the poultry, for keeping eggs, corn, &c. The doors into these are all of lattice work, also painted white, and the framing green. In the middle of the front are four handsome stone columns, and four pilasters, supporting likewise a cornice and a slate roof, under which and between the columns is a beautiful mosaic iron gate; on one side of this gate is an elegant little parlor, beautifully papered and furnished; and at the other end of the colonnade a very neat kitchen, so excessively clean, and in such high order, that it is delightful to view it. This front is the diameter or chord of a large semicircular court behind, round which there is also a colonnade, and a great variety of conveniences for the poultry: this court is neatly paved, and has a circular pond and pump in the middle of it. The whole fronts towards a rich little field or paddock, called the poultry paddock, in which the poultry have liberty to walk about between meals. It happened while the reporter was there to be their dinner time, at one o'clock. At this hour a bell rings, and the beautiful gate in the centre is opened. The poultry being then mostly walking in the paddock, and knowing by the sound of the bell that their repast is ready for them, fly and run from all corners, and rush in at the gate, every one striving who can get the first share in the scramble. At that time there were about 600 poultry of different kinds, in the place, and although so large a number, the semicircular court is kept so very neat and clean, that not a speck of dung is to be seen. This poultry place is built of brick, excepting the pillars and cornices, and the lintels and jambs of the doors and windows, but the bricks are not seen, being all covered with a remarkably fine kind of slate from his lordship's estate in Wales. These slates are closely jointed and fastened with screw nails, on small spars fixed to the brick; they are afterwards painted, and fine white sand thrown on while the paint is wet, which gives the whole an appearance of the most beautiful freestone.

4. Occupation.

Farms very small; a great many under ten acres; only one or two at 350 or 400 acres; excluding all those under ten acres, the average of the county may be seventy acres. Large and small farmers completely different characters: - different in

ing whether the stall feeding of their milch cows might not be continued during the whole year, but he found the general opinion to be against this practice; though it did not appear that any experiments, sufficient for the decision of the point, had hitherto been made. It was suggested to him, however, that it would be an improvement upon the present management, to let the cows stand in their houses during the heat of the day in summer; where, by giving them a few cages or tares, the manure would continue forming, and the cattle be defended from the gad-fly, which, by tormenting them in the fields, frequently injures both the quantity and quality of the milk.

**Time of calving** March and April. At calving-time the cowman, or the master, are frequently up two or three times in the course of a night, to see whether any thing is amiss. The racks and managers are every day well cleaned out, while due attention is paid to the appetites of the different beasts, and the quantity of food is governed accordingly. After this is done, the master himself, generally, goes round from stall to stall just before bed-time, and adds to or diminishes the quantity of fodder as occasion may require.

**In making butter** the whole of the milk and cream is churned together. Cheese is made from the whey pressed from the curd used in making cheese.

**Cheese-making** has remained stationary in Cheshire for many years; best size of cheeses sixty pounds. Cows milked during summer at six o'clock, morning and evening. "The evening's milk (of suppose twenty cows) having stood all the night in the coolers and brass pans, the cheese-maker, in summer, about six o'clock in the morning, carefully skims off the cream from the whole of it, reserving first to take off all the froth and bubbles, which may amount to about a pint: this not being thought proper to be put into the cheese, goes to the cream mug to be churned for butter, and the rest of the cream is put into a brass pan. While the dairy-woman is thus employed, the servants are milking the cows, having previously lighted a fire under the furnace, which is half full of water. As soon as the night's milk is skimmed, it is all carried into the cheese tub, except about three-fourths of a brass pan full (three or four gallons), which is immediately placed in the furnace of hot water in the pan, and is made scalding hot; the half of the milk thus heated in the pan is poured also into the cheese tub, and the other half is poured to the cream, which, as before observed, was skimmed into another brass pan. By this means all the cream is liquified and dissolved, so as apparently to form one homogeneous mass, reserving first to take off all the froth and bubbles, which are poured into the cheese tub. But before this is done, several bowls or vessels, full of new milk, will generally have been poured into the cheese tub, or perhaps the whole morning's milk. Care is taken to skim off all the air bubbles which may have formed, in pouring the new milk into the cheese tub. The night and morning's milk, and melted cream, being thus all put into the cheese tub, it is then ready to receive the rennet and coloring, or, in the terms of the art, to be set together. The rennet and coloring being put into the tub, the whole is well stirred together, a wooden cover is put over the tub, and over that is thrown a linen cloth. The usual time of coming is

7029. **HAMPSHIRE.** A maritime county, which includes also the Isle of Wight: the latter contains 94,000 acres, and the continental part of the county, 963,150 acres. The climate of this country being remarkably mild, and the soil in many places being calcareous, and consequently warm, very early arable crops are produced in some places, and pease grown better than in many districts. The culture of the county, however, has little to recommend it, either in its tillage or pasturage. Its woods are extensive. (*A. and W. Driver's General View*, 1794. *Vancouver's General View*, 1808. *Warner's Isle of Wight*, 1794. *Marshal's Review*, 1817.)

### 1. Geographical State and Circumstances.

**Climate** generally mild.

**Soil** in the central parts, a strong flinty calcareous loam; in other parts generally gravelly, or sandy, and calcareous. The soil of the Isle of Wight is partly a clayey and calcareous loam, and in part lighter.

**Minerals:** none of any consequence; potters' clay, sand, and building-stone in different places.

**Water** scarce in dry seasons, in the chalk districts, where it is preserved in tanks, and drawn up from wells 300 or 400 feet deep. In some parishes after a long dry autumn, there has been more strong beer than water. A good deal of fishing, on the coast; of eels after floods in the smaller streams; and some fish ponds on Bagshot Heath.

### 2. Property.

Largest estates on the chalky districts; largest 8000*l.* per annum. Great bulk of the lands held and cultivated by yeomanry: tenures, copyhold, and leasehold, from the superior lords or freeholders.

### 3. Buildings.

Houses of proprietors numerous: farm-houses mostly of great antiquity; those of the larger kind were formerly grange or manor-houses; out-buildings numerous, and generally ruinous; cottages often of mud (*provin. coe*) walls, but better on the whole than in some other counties. Some fanciful rustic structures as shelters or temporary lodges for cattle, in the forest district. (*fig.* 799.)

### 4. Occupation.

Farms various, rather small.

### 5. Implements.

Hampshire plough, an extraordinarily bulky, clumsy structure; the Suffolk plough is used in the southern parts of the county, and in the Isle of Wight. The patent Hampshire wagon is formed by uniting two carts corresponding with the fore and hind parts of a wagon, by bolting them together. The thill of the hind cart passes under the bed, and rests on the pillow of the fore-cart. The union is simple, yet so complete, as to render this wagon as strong, if not stronger, than the common kind.

### 6. Arable Land.

Tillage difficult and expensive in the chalk district, light and easy in the vale of Avon. Pease a good deal cultivated on the chalks, especially the Marlborough grey or partridge; the charlton and year; in warm situations they are drilled and often sown before Christmas, or in January. "A considerable mystery still seems to hang over certain properties of these pease, with regard to their boiling well for soup or porridge; good

one hour and a half, during which time it is frequently to be examined: if the cream rises to the surface before the coming takes place, as it often does, the whole must be stirred together so as to mix again the milk and cream, and this as often as it rises, until the coagulation commences. A few smart strokes on different sides of the tub, with the cheese ladder, &c. will forward the coagulation, if it is found to be too long in forming.

**The curd is in the next place broke** by the knife and hands, and then left half an hour to subside; then it is gently pressed, the curd broken by the hand, and the whey ladled out of the tub, as it drains from the curd. Afterwards, the curd is broken in a brass pan and salted, and next put into the cheese vat, and pressed with a sixty pound weight, till all the whey is removed. It is then again broke, washed with warm whey, and finally put in the press under a weight or power of about 14 cwt. After being forty-eight hours in the press, it is put in the salting tub, where it remains three days covered with salt; it is then taken out and placed on the salting benches, where it is turned once a day; it is then washed in warm water with a brush, and wiped dry with a cloth; in two hours it is smeared over with whey butter, and then put in the warmest part of the cheese room. In the cheese room it is well rubbed, to take off the sweat or fermentation which takes place in cheese for a certain time after it is made, and turned daily for seven days, and smeared with whey butter; afterwards it is turned daily, and rubbed three times a week in summer, and twice in winter.

**The cheese rooms** are commonly placed over the cow-houses; and this is done with a view to obtain that moderate and necessary degree of temperature so essential to the ripening of cheese, to which the heat arising from the cattle underneath, is supposed very much to contribute. On dairy farms, one woman servant is kept to every ten cows; these women are employed in winter in carding, spinning, and other housewifery business; but in milking, the women, both night and morning, during summer, where large dairies are kept, are assisted by all the other servants, men and boys, except the man who drives the team.

**Sheep** little attended to in Cheshire.

**Horses** brought from Derbyshire and Leicestershire.

**Hogs,** a mixture of long and short eared breeds.

**Poultry** of the common kind abundant in most farms for their eggs. Geese kept by the cottagers till midsummer or later, and then sold to the farmers, who fatten them on their stubbles.

**Bees** to be found at many of the farm-houses, and at some of the cottages.

### 12. Political Economy.

Roads bad; various canals, an extensive commerce of coal and salt, and manufactures of silk, woollen, linen, and cotton. An experimental farm established at Waverham, near Northwich, by some gentlemen and farmers of the neighborhood, but it was soon found so expensive and losing a concern as to be abandoned. Those on the plan suggested by Bailey, (7024.) seem the most likely to be effective and permanent.

bolters being sometimes sown upon fields which have never been known to refuse yielding a produce possessing a similar quality, but that effect afterwards ceasing, and a hard indis-

799

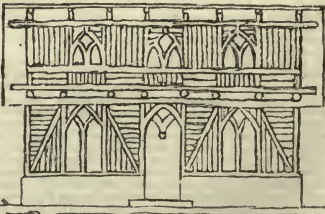

soluble pea has been produced that continued for several successive periods; whilst on the other hand, land that had never been known, or even suspected of being able to communicate a boiling quality to its pease, would unexpectedly give to the produce of a hard, and almost impenetrable pea, all the properties of being excellent bolters. Through all the cedar-colored sand, and gravelly loams in Devonshire, good bolters are stated to be uniformly produced, and in continued succession. The same kind of soil, and in every respect under similar circumstances in the Isle of Wight, will only occasionally, and by accident as it were, produce good boiling pease. Some opinions seem to refer this effect to a peculiarity in the seasons; but this cannot stand against a well known truth, that good bolters are produced every season.

Saintfoin cultivated with success on the chalky soils, and very productive. Hops on the borders of Surrey. A vineyard was planted at Undercliff, in the Isle of Wight, by the late Sir Richard Worsley, in 1792, and an Anjou vine-dresser brought over to attend it; the extent was about two and a half acres, and a light wine was made; but in 1808, when M. Vancouver called to see it, he found the vines had been grubbed up, and the ground changed to a lawn of turf.

### 7. Grass Lands.

The county famous for water meadows, which are well ma-

maged, and productive; they are chiefly in the neighborhood of Winchester, on the Itchen; but there are instances on most of the other rivers and streams.

8. *Gardens and Orchards.*

Excellent market gardens near Gosport and Portsmouth; Portsea island noted for its brocoli; white-washed mud walls, with copings of thatch used as fences, and for wall fruit in some cases; and fruit walls only half a brick thick, and waving at the rate of one foot in twenty in use. In other cases angular walls are in use, the angles being right angles, and the sides ten feet each. The advantage, in all cases, is the saving of bricks; but it is evident they cannot be carried very high, nor, as subject as they are to the driving and drawing of nails, can they be of great duration. (See *Encyclopedia of Gardening*, 1567.) Orchards in various places, and cider made both in the county, and in the Isle of Wight.

9. *Woods and Plantations.*

Extensive beechwoods on the chalk district, those of Ditcham grove very fine; elm scarce in the county, but abundant in Strathfieldsay Park (now the Duke of Wellington's). Oak abundant in the New Forest district, and many young plantations there, and throughout the county. Cobbett raised a great many American trees of various species at Botley. There are several considerable forests, viz. the New Forest, Alice Holt, Woolmer, and Bere.

The *New Forest* is situated on the south side of Hampshire; it was formerly bounded on the east by Southampton river, and on the south by the British Channel, being near thirty miles in length, and ninety in circumference; but since the disafforestations by Henry the Third, and Edward the First, its boundaries are much reduced, and now only extend from (tidal) shore, on the north west, to the sea, on the south-east about twenty miles; and from Hardley, on the east, to Kingwood, on the west, about fifteen miles; containing within those limits about 92,565 acres, the whole of which does not now belong to the crown, as several manors and freehold estates, to the amount of 24,797 acres, are private property; about 625 acres are copyhold, belong to His Majesty's manor of Lyndhurst; 1004 acres are leasehold, held under the crown; 902 acres are encroachments; 1195 acres are held by the master-keepers and groom keepers, attached to their respective lodges; and the remaining 63,844 acres, are the woods and waste lands of the forest. The other forests are of much less extent and interest.

10. *Improvements.*

Good examples of draining by tapping, were exhibited by Elkington, on Gadland Park estate; the strata lying at a small angle with the horizon, enabled the principles of what is called Elkington's mode of draining, to be carried completely into effect. In the eastern part of the Isle of Wight, are various tracts of marshy ground, the largest of which, Brading Haven, containing about 900 acres, was granted by James I. to one Gibbs, a groom of the bed-chamber. The owners of the adjoining lands contested this grant, which the king was very anxious to support. After a verdict obtained in the Court of Exchequer against the gentlemen of the island, Gibbs sold his share for 2000*l.* to Sir Bois Thelwall, a page of the king's bed-

chamber, who admitted the famous Sir Hugh Middleton to a share. They employed a number of Dutchmen to enclose and recover the haven from the sea. The first taking of it in cost 4000*l.* and 1000*l.* more was expended in building a dwelling-house, barn, water-mill, trenching, quicksetting, and other necessary buildings, so that including the original purchase, the total expenditure amounted to 7000*l.* But after all, the value of the ground did not answer the expectations of the undertakers; for though that part of it adjoining Brading proved tolerably good, nearly one half of it was found to be a light running sand; nevertheless, an incontestible evidence appeared, by the discovery of a well, cased with stone, near the middle of the haven, that it had formerly been good ground. Sir Hugh Middleton tried a variety of experiments on the land which had been taken in, before he sold his share; sowing it with wheat, barley, oats, cabbage, and finally with rapeseed, which last was alone successful; but the greatest discouragement was, that the sea brought up so much ooze, weeds, and sand, which choked up the passage for the discharge of the fresh water. At length, in a wet season, when the inner part of the haven was full of fresh water, and a high spring tide, the waters met under the bank, and made a breach. Thus ended this expensive project; and though Sir John Olander, who lived in the neighborhood, confesses himself a friend to the undertaking, which, besides its principal object, tended to render that part of the country more healthy, he declares it as his opinion, that the scheme can never be resumed to any profitable purpose.

11. *Live Stock.*

No exclusive breed of cattle. The Sussex, Suffolk, Leicester, Hereford, Devon, &c. are indiscriminately met with. Several ox teams.

*Sheep.* In the Woodland district the heath sheep, old Hampshire, or Wilts breeds, but most of the improved breeds also to be met with.

The *Horses* used in teams generally large, heavy, inactive animals. Small horses bred in vast numbers upon the heaths and forests, and which have not improperly acquired the name of heath croppers. Their ordinary height is about twelve hands. They propagate indiscriminately upon these wastes, where they seek their living throughout the year, and at four years old may generally be purchased at about five pounds.

The *native hog* of this county is a coarse, raw boned, flat sided animal, agreeing in no respect with the idea entertained of it in other parts of the kingdom. The great number fed for a few weeks in the use of autumn, upon the acorns and mast which the forests and other woodlands produce, in the county, and the excellent mode of curing hog-meat practised by the housekeepers, have contributed in a far greater degree to establish that superiority ascribed to Hampshire bacon, than any inherent excellence in its native breed of hogs. Very few, however, of the genuine native hog are to be met with, the common stock being either the native Berkshire breed, or a considerable predominance of that blood in the native swine of the county.

12. *Political Economy.*

Roads in general good, especially in the New Forest. Several canals, and various manufactures and public works at Portsmouth and other places.

7030. WILTSHIRE 878,000 acres of varied surface, partly chalky downs, and partly rich vale land; and both a corn and grass county. It produces excellent cheese and butter, fat cattle, pigs, and store sheep. The agricultural report of this county was drawn up by T. Davis, steward to the Marquess of Bath, at Longlent, a man of great experience as a land steward, surveyor, and farmer, and universally respected. He divides the county into two districts, the south-east, and north-west, a very judicious plan for giving correct agricultural information. (*Davis's Wiltshire*, 1794. *Marshal's Review*, 1809.)

7031. *South Wiltshire.*

Wiltshire downs contain about 500,000 acres of hilly surface, mostly unenclosed and in common pasture; the atmosphere cold and sharp, with a chalky soil, seldom varied by patches of loam, sand, or other earths. There is scarcely a river or brook in this district which is not applied in some way or other to the purposes of irrigation.

1. *Property.*

New large towns property is generally subdivided when sold in this district, when any is sold it is generally bought up by such as are considerable proprietors, hence estates generally large. Shape of the manors shews that many of them were the property of one lord; each borders on, or contains a rivulet for water and meadow, and a hill for wood, or where these were wanting, they were supplied by a grant of those articles from other property. Proprietors generally resident on their estates.

2. *Buildings.*

Farm-houses generally crowded together in villages, for convenience of water. Some of late years erected central to their farms, by the Earl of Pembroke, and other proprietors; wells and ponds an important article in these erections.

3. *Occupation.*

Farms of two kinds; those in severalty or not subject to rights of common, are from 150*l.* to 500*l.*, and one or two at 1000*l.* a year; customary tenements, subject to rights of common, are from 25*l.* to 40*l.* or 50*l.* per annum. Tiers are extensive sheep commons and cow commons, to which the occupiers of both descriptions of lands have a right to turn in stock according to certain fixed and customary regulations. Leases seven, fourteen, or twenty-one years.

4. *Implements.*

A heavy two wheel and one wheel plough in use; the latter sometimes with a foot instead of a wheel.

5. *Arable Land.*

An old error, that of over pulverizing the uplands by too frequent ploughings, by which the wheats were thrown out during winter, or if they stood the winter, the March winds blew away the earth from their roots, and "hanging by one leg," thus not receiving assistance from the carol root, the plants are weak in straw, and produce small thin ears. Many modes have been introduced to prevent this evil, by giving a sufficient texture and firmness to the land previous to a wheat crop. The best farmers have made a point of getting their lands clean ploughed by midsummer, and treading it as firm as possible with the sheep-fold a long time before sowing; while the slovenly farmers have invented, and generally prac-

tise, a very short and cheap way of attaining this firmness in the land. They rafter the land (as they call it), that is, they plough half of the land, and turn the grass side of the ploughed furrow on the land that is left unploughed. This is as soon as they can spare the feed of the summer-field, and leave it in that state till near seed time, when they harrow it down and plough it for sowing. This rafter is usually ploughed across the ridges, or what is better, diagonally; the latter mode being less subject to drive the land up in heaps before the plough. The land thus rafted is sometimes ploughed twice, or frequently only once, previous to sowing; and after it is sown they drag it two, three, or four times, and harrow it four, five, or six times. A very heavy kind of drag is used, and as Wiltshire Down farmers are very cautious of ploughing their land too much, they make much use of these drags instead of ploughing, and frequently let in their seed-wealth with them. This practice having been found to answer, has been gradually improved upon. The down lands of this district will not bear fallowing, especially in dry weather; they are too thin and light already, and require seed. Two years' rest for wheat is equal to the best coat of dung. Dung may give the quantity, but rest must give the quality.

The *course of crops* was formerly fallow, wheat, barley, oats; but now, even on the common fields, is wheat, barley, clover, mowed one year, and fed two years, till it is necessary to plough for wheat. Turnips, swedes, and rape ground for winter food for sheep, though less necessary than in districts less amply provided with water meadows. Error that of sowing too much corn.

*Gardens* near Devizes, Lavington, Warminster, Westbury, &c. Many families subsist by this kind of husbandry, occupying from two to five acres each as garden ground. The produce supplies the adjacent towns in the district, and Frome and Bath, in the county of Somerset, with cabbage-plants, pease, beans, carrots, turnips, and vast quantities of potatoes.

*Orchards* in some places, and cider made; but as the district is famous for its barley and ale, the predilection for this beverage renders the want of cider little felt.

*Woods* not numerous, but a great spirit for forming plantations; and some excellent remarks on the subject in the Report.

*Irrigation* introduced into this district the end of the seventeenth, or the beginning of the eighteenth century. Many of the most valuable and best formed meadows, particularly those in the Wyley Bourne, were made under the directions of one Farmer Baverstock, of Stockton, between the years 1700 and 1705.

Between 15,000 and 20,000 acres watered; its great value in April between "hay and grass, by which the farmer is en-

abled to breed early lambs." As soon as the lambs are able to travel with the ewes (perhaps about the middle of March), the flock is put into the water-meadows. Care is, or ought to be taken to make them as dry as possible for some days before the sheep begin to feed them; and on account of the quickness of the grass, it is not usual to allow the ewes and lambs to go into them with empty bellies, nor before the morning dew is gone. The general hours of feeding are from ten o'clock in the morning till four or five in the evening, when the sheep are driven to the fold, which at that time of the year is generally in the barley fallow. The grass is daily huddled out in portions, according to the number of sheep, to prevent their tramping it down; but a few spaces are left in the hurdles, for the lambs to get through, and feed forward in the rich grass. One acre of good grass will be sufficient for 500 couples for a day; the great object is, to make the water-grass last till the barley sowing is finished; the meadow is then laid up for hay.

The water-meadows of *Orcheston*, a village six miles N. W. of Arnesbury, have been long celebrated. What is called the long grass of these meadows is the *agrostis stolonifera* or black couch "one of the worst grasses," says Davis, "in its native state which the kingdom produces, and the peculiar plague of the farmers of the district, especially in those low lands, which are so too poor to bear the white couch (*Triticum repens*), and is the general and almost only herbage of the old, burnt, worn-out downs, and in that situation is so coarse and wiry, that no cattle will eat it. It forms a thick tough covering over the lands which preserves itself, and destroys every thing else. But in these meadows, when fed abundantly with water, it is fit for just such uses, and the peculiar plague of the district, particularly for sheep. These meadows are not laid out in any regular form for watering, the supply of water being too partial, but they depend entirely upon the floods; and being situated at a sharp turn of a narrow part of the valley, the water makes an eddy, and deposits its sediments upon them.

The substratum of these meadows is an almost entire bed of long flints, in the roots of grass freely run, and produce strong succulent shoots, which fall down, and taking root at the joints, send forth other shoots, which, in like manner, drop and root again, so that the stalk is frequently eight or ten feet in length from the original root; and though the cup is exceedingly thick, it is, perhaps, not eighteen inches in height. But this grass, though very abundant in these two meadows, prevails in most of the meadows which lie below them on the same stream; and whenever the winters are productive of floods, the grass in all of them is abundant in quantity and succulent in quality, and the hay is exceedingly nutritive; but in a year when water is scarce, their produce is extremely small, and of a very bad quality.

On examining other meadows in different bournes of this district, we find the same grasses abound in those situated near the springs-heads, and which in some years have plenty of water, and in others none at all. The same remark on its variation in quality and quantiv, according to the wetness or dryness of the winter, is equally just. The most probable way of accounting for it is, that it is almost the only grass common to water-meads that will stand wet and dry; for though it nourishes most when under water, yet no dry weather will kill it.

**Live Stock.** Cattle few in this district; oxen not generally under the plough; sheep the chief stock and the basis of the Wiltshire Down husbandry; object, folding and wool; breeding a consequence rather than a cause of keeping sheep. Horses a heavy very unsuitable breed; great error in principle of breeding here as every where among the old school, that of enlarging the size of the animal.

### 7032. North Wiltshire.

Climate milder than that of the S. E. district; soil not so uniform; under-stratum broken stones, and surface reddish calcareous loam.

Property more divided than in the east side of the county. Buildings. Charlton, a noble pile, by Inigo Jones. Farms generally enclosed, and chiefly under grass, and applied to the making of cheese; leases from fourteen to twenty-one years.

Scottish farmers. "Within these few years, several of the great landholders in Wiltshire have introduced into this district Scots farmers, who, from a supposed superior skill in the science of agriculture, have leases for twenty-one years, with scarcely any restrictions as to husbandry. The ancient pastures are allowed to be broken up, buildings are erected for their accommodation at a low rate of interest, and a degree of counte-

7033. DORSETSHIRE. 512,154 acres of undulating surface, in great part chalky soil, and celebrated from the time of the Romans for its pleasantness and fertility. Like Berkshire and some other counties, it is called by the inhabitants the garden of England. It is chiefly under grass, and is celebrated for its breed of sheep, which bring three lambs in two years, and for its watered meadows, of which Boswell, of this county, has given a valuable account. (*Claridge's General View*, 1793. *Stevenson's General View*, 1812. *Marshal's Review*, 1817.)

### 1. Geographical State and Circumstances.

Climate dry and salubrious rather than mild and bland; supposed colder since the elevated downs were denuded of their native forests.

Soil chiefly chalk, next clay, then sand, and of loam, gravel, &c. nearly equal and moderate portions. Chalky and sandy soils of the uplands very thin.

No metallic mines or cauls, but the peninsula of Portland four miles and a half in length by two in breadth, one entire quarry of Portland stone, so extensively used, especially in London. Pottery clay found in various parts of the county.

### 2. Property.

Estates large compared with those of other counties; some of the principal under the crown, in the hands of barons, others of lawyers. Tenures chiefly freehold and leasehold.

### 3. Buildings.

Farm buildings as in other counties; generally ill situated, built of stone, and covered with reeds or thatch.

### 4. Occupation.

Farms very large, 1500 or 2000 acres of sheep farm being frequently to be met with. Many of the proprietors great farmers. Leases of twenty-one years common till the beginning of the present century, now for shorter periods.

nance and patronage given to them above the other tenants of the day. These men give nominally a large rent for their farms; but as their maxim is to pay neither repairs, tithes, or parochial taxes of any description (these dues and services being all included in the rent received by the landlord), I have strong doubts whether the advantages held out to the land-owners will be ultimately any increase of net cash into their pockets. It is strong in many of the counties, and I am aware much profit may be made by an economical system of husbandry in the tillage; but the practice of the Scots farmers not embracing sheep, or water-meadows, will never make them rich on the Down farms of Wiltshire; and if the Downs be broken up by the tenants, who have no stock to maintain them, the land and the farmer will soon come to poverty together." (*Darwin* 174-5.) Among these farmers was the unfortunate Gourlay, who was ultimately ruined by the speculation. Of his farming we know nothing, nor are we aware what description of Scotch farmers they can have been whose husbandry in an inland turnip district did not embrace sheep. On the Earl of Suffolk's estate at Charlton, some Berkshire farmers were introduced in part through our means, whose chief object was the sheep system. Lord Suffolk, however, who is a weak man, without an opinion of his own, was so alarmed, when he learned the idea of breaking up old turf, that he bought up the leases of these farmers almost as soon as they were granted.

The arable part of this district is on the north-west verge, being a part of the Cotswolds hills, and treated like them.

Grass land prevails almost to the exclusion of arable on all the wet and heavy lands; their management of late much improved by draining, mowing, and wintering, early mowing, and feeding and mowing every piece of land alternately. The grand object in these improvements is, to get an early bite for the cattle in the spring, and thereby, in fact, to shorten the winter.

The cheese of this district was many years sold in the London market by the name of Gloucester cheese; but it is now perfectly well known by the name of North Wiltshire Cheese. It was first so called, as an imitation, and perhaps an humble one, of that made in the vale of Gloucester, but it is now allowed by many to be at least equal, if not superior, to the cheese of the favorite district of Gloucestershire, the hundred of Berkeley.

Gardens not numerous; some near Wootton Bassett, for supplying the markets of Cricklade, Cirencester, &c.

*Orchards* very frequent as an appendage to farm-houses, but no cider made.

Wood frequent in hedgerows, but not in masses.

Irrigation not common; springs scanty, and land too absorbent; alleged they produce coarse grass, but this is owing to its not being mown in time.

### 6. Live Stock.

Cattle of the long horned breed; Devons bred, and found better for fattening, but it is questionable if they are so good for the dairy. Breeding cattle not the fashion. "The dairy men say, that the advantages which their situation gives them of sending their veal to London and Bath markets, makes it more their interest to fat their calves than to wean them for stock; but the opponents of the long horned cows say, that the oxen are generally so ugly, and the heifers frequently such bad milkers, that the farmers are never certain of breeding such as they would wish to keep; and, therefore, they prefer buying cows (of which they can have a choice) to breeding them, and to use horses for the plough instead of oxen."

Many sheep bred in the district; some for folding, and others purposely for fattening; for these purposes a kind to walk, and a kind to stand still necessary; the Wiltshire answers the former purpose, and the Leicester the latter.

There are yet left in North Wiltshire a few flocks of the native Wiltshire horned sheep, possessing qualities of perfection, both for folding and fattening, which stand short in the leg, with wool under their bellies; are wide and heavy in the hind quarter, light in the fore quarter, and in all their offals, with the Roman nose, and quick piercing eyes. These are in the hands of a few farmers near Broad Hinton.

### 7. Political Economy.

As applicable to both districts it is observed, that the turnpike roads are numerous and good in most places; three canals; extensive woollen manufactures at Salisbury; also cutlery of superior excellence there; carpets at Wiltton and fancy woolsens; and of superfine broad cloths at a great many places. No agricultural society, but many farmers and others are members of the Bath and West of England Society.

### 5. Implements.

Two sorts of uncouth wheel-plough in use. Small's plough tried one or two places; from the difficulty of ploughing flinty soils wheels are deemed an advantageous appendage to whatever sort is adopted. Threshing, winnowing, and various other modern implements introduced in a number of places. The wattled hurdles of Dorsetshire consist almost invariably of ten stakes, which the hurdle-makers drive into auger holes, that are made for that purpose in a piece of timber, which is supported at a convenient height from the ground by other pieces of timber, and then the stakes are wattled. Stones set on edge, and rubestone walls used as fences in various parts.

### 6. Arable Land.

The deep ploughing generally less approved of on the chalky soils, and cross ploughing never practised, even for turnips; two or three horses form a team. Fallowing general all along the coast; but what is here termed a summer fallow, is, in most cases, no other than a preparation of ley ground for a crop of wheat, by ploughing it three or four times, the first ploughing being given in June or July, and sometimes as late as August.

Upon this chalky soils around Blandford, and upon the hills in the neighborhood of Abbey Milton, the course of crops with the best farmers is as follows: viz. one-seventh of the lands



4s in sainfoin, and the rest of the arable is cultivated in the rotation of, one, wheat; two, rye, winter barley, or winter vetches, to be fed with sheep in the spring, and the whole followed by turnips, rape, &c.; three, barley or oats; and four and five, artificial grasses, to be followed by wheat as before.

Upon the thin chalks and shallow fertile loams, wheat is generally sown on the back of a two years' clover ley, but even on those thin soils, a great deal is sown after turnips, rape, &c. fed off with sheep early enough to sow it in the same autumn, and in most instances a good crop is produced of a fine sample. On the better sorts of chalky and gravelly soils, the same practice prevails, except upon the ley-ground, which continues in grass but one year instead of two; the wheat is taken after the first year's ley, and is supposed to answer better than it would in the second year, upon the latter description of soils. Old sainfoin leys broken up without paring and burning. Hemp and flax a good deal cultivated.

**7. Grass.**  
300,000 acres, or about three-fifths of the county; 6000 acres of meadow in the chalky district irrigated. Application of the meadows, fattening cattle, and of the uplands the dairy.

**8. Gardens and Orchards.**  
Both are frequent appendages to farm-houses and cottages; some of the cottage gardens are small enclosures taken from the sides of the highways. The goosefoot (*Chenopodium bonus-henricus*) cultivated by a few persons here, as in Lincolnshire and elsewhere, and calculations made by Hatchler, to show what would be the expenses and profits of an acre for the London market. The plant is greatly inferior to spinach, but might be used as a substitute for it in spring, as it is a perennial, and very early in leaf. Sea kale, which grows on the shores near Burton, is now generally introduced into the gardens of farmers.

**Orchards** to the extent of 10,000 acres; application cider; in making which hops are sometimes added to make it keep; proportion one pound to a hoghead. Twenty bushels of apples will make a hoghead of cider.

**9. Woods and Plantations.**  
Timber scarce, and chiefly to be found in parks and hedge-rows. Many young plantations lately made on, the heath lands.

**10. Improvements.**  
Irrigation carried to considerable extent and great perfection, and one of the best in the subject is by Boswell, of Fiddletown. A dry meadow of good quality is worth forty shillings; watered, sixty-five shillings per acre; produce of hay two loads per acre. The streams in Dorset are in general shallow, and have a considerable fall; the meadows are narrow, and the water is supplied with comparative regularity, in consequence of its having to filter through immense masses of chalk previous to its exit at the springs; and hence the process of irrigation is much facilitated.

The sheep of Dorsetshire are well known as supplying the metropolis with house-lamb at a very early season. Farkinson considers the Dorset ewe as the best horned ewe in the kingdom, those of Somerset excepted, and they are so nearly alike, that few people, excepting the natives of the two counties, would know the difference. In the Isle of Portland there is a small breed, which some contend is the true breed of the county. Lowman, of Portland, observes, it is the practice there to fold these dwarfish animals from Candemas to Martintide, putting them in late at night, and letting them out early in the morning. The mutton is deemed the best in England, and the wool as good as the South Down kind. Some of them have been purchased by sheep-breeders, with a view to obtain a cross between these and the Merinos. Both ewes and wethers are kept, and generally till they are five years old; sometimes they

remain till a greater age, but it is not thought a profitable method. Such as are fattened are put into a common, at the northern part of the island, which is pretty good land, and remain there from the 12th of August to the 5th of November, on which day Portland sheep-fair is held. All the sheep of the island are kept pretty generally upon the commons from November the 21st to Candemas. The Portland mutton, from November by the quarter in general at ten shillings and sixpence. It is never weighed, but would come to one shilling a pound when common mutton is only seven-pence: it seldom weighs more than ten pounds a quarter. Several flocks of pure Merinos, Down Merinos, and other breeds.

**General management of sheep.** The lambs which are bred for the regular supply of the flock, are dropped at Christmas, or soon afterwards, and the couples are kept in the best ewe-leazes, &c. on grass, hay, and turnips, if necessary; and such as have watered meadows, depasture their sheep there, on the early grass, till old May-day, when the lambs are weaned, and the sheep go to fold; but sometimes the two latter circumstances take place as early as Lady-day. The ewes are folded constantly, and kept on the Downs, on artificial grasses and other pastures, till near the ensuing Christmas, at which time they have another crop of lambs, the rams having been put to the flock about the end of July.

There is, probably, no part of England where the practice of sheep-folding is more admired, or more earnestly pursued, than in the county of Dorset. Fifteen dozen of hurdles, with a like number of wickets and wickets, and four asses with sufficient, will enclose a statute acre of ground, and will contain 1200 or 1300 sheep very commodiously. The hurdles are moved every morning, consequently the same number of sheep will manure an acre of land daily. The real value of the fold there is no means of ascertaining; it is, undoubtedly, very beneficial to the arable land, but it has reduced the Downs to a state of poverty.

Ewes are generally kept till they are four years and a half old, when they are sold to the dealers. A singular custom prevails of coloring them with ochre, for which no other reason is given than that of being able to distinguish them from the Somerset sheep.

Asses were formerly kept by some farmers, but are now given up, having been found destructive to hedges, &c. "It appears, however, that the asses would plough as much land of any kind in a given time as three horses, and four asses would suffice to plough broken land. It is believed that two asses will perform as much work as one horse, and they do it more conveniently in the hilly part of the county, as they carry their lading in panniers, where it would be difficult to use wheel carriages.

Geese kept on the corn pastures in Purbeck, from an idea that they promote the health of the cattle.

Bee kept in various places; does not answer to feed them; the only way to render them profitable is, after the honey-season to destroy all hives under twenty pounds weight.

**11. Political Economy.**  
Roads of flint, and in general good: an iron railway, of three miles and a half, for conveying potters' clay from Norden to a place opposite Poole, where it is shipped for Liverpool. No canals. Manufactures of flax and hemp at Bridport and Beaminster; upwards of 2000 people employed in making sail-cloth, cordage, sacking, tarpaulin, &c.; lannel at Shaftsbury, and woollens at Lyme Regis; twisting and making up a few silks into skeins at Sherborne and other places; shirt buttons extensively at Shaftsbury, Blandford, and the surrounding villages; the buttons made of wire and thread; many thousands of children in this manufacture: wicker baskets, with a small hole at top, called lobster pots, at various places on the coast, and a variety of other articles. Many very uncommon provincial terms used in this county.

**7034. SOMERSETSHIRE.** About one million of acres, chiefly of meadow and pasture land, hilly and mountainous in some places, and with marshes and bogs in others, but on the whole, though far behind in artificial culture, celebrated for its natural fertility. The climate is various, in general cold and boisterous on the elevated parts, but almost without a winter near the sea. The county is divided into the north-east, middle, and south-west districts, by its very able reporter, J. Billingsley, Esq. of Ashwick Grove. (*Billingsley's General View, 1797. Marshal's Review, 1817.*)

**7035. North-east District.**  
Surface very irregular, intermixed with lofty hills and rich fertile plains: climate various; soil chiefly clay, and in part peat; application chiefly pasturage; several thousands of acres overlain by the tide in the river Ye0; 4000 acres protected by a wall of stone and lime, elevated ten feet above the level of the land within, but high tides frequently break over it and make breaches.

**Minerals.** Lead and calamine in the Mendip hills, but little worked, for want of a proper level to carry off the water. Coal abounds, and is worked for the supply of Bath, Wiltshire, and Somersetshire: from 800 to 1000 tons raised weekly.

**Property.** Many large proprietors from 2000*l.* to 6000*l.* per annum, but the greater part in the possession of respectable yeomanry, from 50*l.* to 500*l.* a year.

**Buildings.** There are many splendid gentlemen's seats, or manor-houses with extensive plantations, in this district, and the farm-houses and cottages are for the most part commodious and comfortable; but on all the dairy farms, a shameful wantonness prevails in respect to outhouses and sheds for their stock to retire to in the winter months. Cattle are almost universally served with their provender in the field; and many a dairy farmer, with twenty cows, scarcely makes, in the whole winter, a quantity of dung sufficient to manure one acre of land.

**Occupation.** Farms seldom exceed 200*l.* a year; some of the dairy farms are so small as not to exceed 60*l.* or 70*l.* per year; and many instances can be produced of such little farmers bringing up a large family in a very respectable way. In such instances, it is generally found that the wife undertakes the whole management of the cows, and the husband goes to daily labor.

**Implements.** Plough with a foot or wheel; spade with the blade curved in its breadth, to prevent adhesion of soil: it is much narrower and longer than those used in other counties, eighteen inches by six inches.

**Arable land** but in small proportion, and little attended to. Teazles and woad grown for the clothiers; potatoes cultivated to a very considerable extent. The Reporter has known thirty-

two successive crops of potatoes, from the same field, and the produce as good at the latter part of the term as at the beginning. This will puzzle the theorist, with his peculiar substances of nutrition. A sack of potatoes is equal to 100 weight of hay.

**Grass,** the predominating surface. "On the rich marsh land near the Bristol Channel, the grazing system prevails. In the vicinity of Bristol and Bath, the scythe is in constant use; and at a greater distance nothing is scarcely seen but the miking pail: on the stone-brash, and freestone grit soil, sainfoin takes the lead: next to sainfoin, rye grass, marl grass, and white Dutch clover are in deserved repute, when the land is intended to remain some years in grass; but when it is intended to be ploughed again in the course of a year or two, broad clover is preferred to all others.

**Hay** (857.) much in use, by which means it is considered as much nourishment is obtained, as if the hay were eaten, while after boiling, the culms may be dried and used as litter!

**Market Gardens** for the supply of Bristol and Bath. A clergyman has eight or ten acres of nursery ground, the labor of which amounts to 25*l.* per acre.

**Orchards** abound throughout the whole district; the favorite apple, both as a table and cider fruit, is the court wick pippin, a seedling from the golden pippin.

**Woods and Plantations** not numerous.

**Live Stock.** Cattle mostly short horned; the long horned breed of North Wiltshire have been tried, but the customary breed preferred. Both cheese and butter made.

**Wool** pretty good; some cannot stock manufacture, extensive, and that of knit worsted stockings considerable.

**7036. Middle District.**  
Between 4 and 500,000 acres of varied surface and soil, and mild climate; including a great extent of marsh and fen land, great part of which has been drained and embanked. Half this district occupied by the owners. Grass the chief product, farms from 40*l.* to 600*l.* per annum, partly grazed with heifers, but chiefly by cows for the dairy: the cows let out to dairymen, as in Dorsetshire.

*Arable Land*, flax and hemp extensively cultivated, and also turnips.

*Orchards* numerous and very productive; soil particularly suitable; plantations few.

*Live Stock*. Small cows, well fed, preferred for the dairy, and the object chiefly cheese; that of Cheddar much admired; the others in general sold in London as double Gloucester. A dairy maid can manage the milk of twenty cows.

*Roads* excellent, especially from Wells to Bridgewater; extensive woollen manufactures, many of hemp and flax, and some of gloves.

**7037. South West District.**

Rough mountainous hills, and rich fertile slopes and plains; farms rather less than in the last district, but the husbandry much the same; more land in tillage; mountains uncultivated, and pasture with sheep and young bullocks; in the vicinity of these hills, the principal corn crop is oats.

*Fences*. The beech hedges around Dulverton, Dunster, &c. are not only beautiful to the eye, and excellent fences and shelter, but are a source of annual profit to the proprietors. The banks on which they are planted, are six or seven feet high,

**7038. DEVONSHIRE.** 1, 595,309 acres of strongly marked hilly surface, including the vale of Exeter, "the garden of the west," the Forest of Dartmoor, a barren waste, and North, West, South, and East Devonshire, each with distinct features. The county is celebrated for its breed of cattle, its dairy, and its orchards, and of late years for extensive improvements undertaken in Dartmoor, where is also the immense depôt for 10,000 prisoners of war. (*fig. 800.*) (*Tyrwhitt's Tracts on the Improvements at Dartmoor, 1819. Fraser's General View, 1794. Vancouver's View, 1807. Marshal's Review, 1817.*)

800

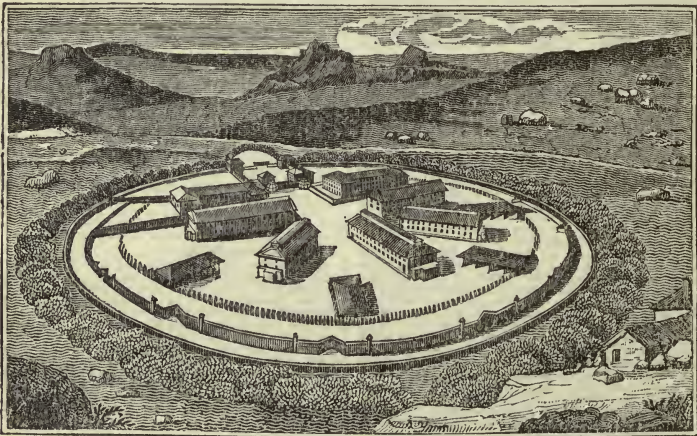

**1. Geographical State and Circumstances.**

*Climate* in North Devon less mild than in South Devon, but still myrtles are used as garden hedges; in South Devon the climate is supposed more mild and salubrious than in any other part of England.

*Soil* in great variety, but in general calcareous.

*Minerals*. Some iron and copper worked, also freestone, limestone, and marble, &c.

**2. Property.**

Much divided, only a few large estates; formerly letting for lives much in use. "It has frequently happened, that in letting an estate, the landlord agreed to discharge tithes and all parochial payments. About the years 1800 and 1801, the rent of several estates in this county was absolutely insufficient to meet such disbursements, and consequently all the estates so circumstanced, brought their proprietors in debt."

**3. Buildings.**

Houses of proprietors too generally going to ruin from non-residence. "We defy ingenuity to plan and place farm-houses worse than they are." "Garden-walls, farm houses, barns, stables, lime kilns, village fences, and cottages, are all built with mud, and left without rough cast, or white wash, to conceal the native color of the loam."

**4. Occupation.**

Farms of all sizes from 10l. to 500l. a year

**5. Implements.**

Plough of the swing kind, with a wooden mould board. Scarifiers, called tormentors. Two sorts of grubbing mattocks are in use (*fig. 801 a, b.*), one called the hoe mattock (*a*), and the other a two bill or double-tipped mattock (*b*). Paring shovels (*c*) are very well constructed. Corn stacks in harvest secured from the sudden and heavy thunder showers, to which this country is liable, by canvass coverings, like those used in Mid. dlesex for covering hay ricks.

**6. Arable Land.**

Much less than the grass land; not much to be learn-



ed and between four and five feet wide at the top; the mouldering of the sides is frequently prevented by a dry stone wall, four feet high. There is no ditch; and the hedge consists of three rows of beech, planted on the top of the bank, at about one foot distance. Their growth is very rapid, and they seem to defy the destructive qualities of the sea breezes, so fatal to the white-thorn, and most other plants; when at maturity, the middle row is cut to the ground, and the outside rows plashed. The quantity of fuel supplied by these hedges is very considerable; and the only objection that can be made to them is, that the earth used in the construction of the banks is so considerable a quantity, that a large portion of the field is robbed of its vegetable matter, and rendered for some years unproductive.

Some *Norfolk farmers* introduced on the Barnard estate, and rhubarb cultivated to great perfection by Ball, at Williton, near Watchet. Many orchards, and excellent cider made; not much wood, but elms attain to a large size in the hedges.

*Live Stock*. North Devon cattle, and Dorset sheep used round Taunton Dean; oxen worked chiefly in yokes. Manufactures at Taunton on the decline. A salmon and herring fishery at Porlack, Minehead, and Watchet.

ed from its culture; artificial herbage not generally sown, and rotations bad.

**7. Grass Land.**

The low tracts of good quality; application, breeding and the dairy; butter good, cheese indifferent, and generally consumed in the county.

**8. Orchards, Woods, and Plantations.**

Very abundant in most parts of the county, and excellent cider made in the Herefordshire manner. Fruit trees rather neglected as otherwise; generally pasture beneath; often in the hedgerows.

The *Forest of Dartmoor* belongs to the Prince of Wales, and is parcel of the Duchy of Cornwall; extensive improvements have lately been proposed, and in part carried into execution, under the direction of Sir J. Tyrwhitt, the steward of the Duchy. Extensive salt marshes on some parts of the coast.

**9. Improvements.**

Draining and irrigation not much practised. The Rev. M. Froude, of Darlington parsonage, communicated to Vancouver, a mode of emptying the water from a pond without the necessity of attending to it personally when full. It is more matter of curiosity than ingenuity or use. The water when the pond is overflowing, flows by a gutter into a basin, suspended beyond the head, which when full, by means of a lever, raises a plug at the bottom of the pond. After a time, the box being leaky, it becomes empty, and when the pond is nearly empty, the plug re-drops in its place. If the plug were placed nearer the surface of the water, it would in general cases be more useful and less likely to lose the fish.

**10. Live Stock.**

The North Devon cattle well known for their superior adaptation, both for feeding and draught. For the uses of the dairy or for milk, it is a breed by no means held in general estimation, as their aptitude to look well (without being fleshy), is derived from the peculiar nature of the animal, which disposes its secretions in the accumulation of fat, rather than in the production of milk. For the purposes of labor, this breed can no where be excelled for docility, activity, or hardihood, in proof of which no stronger circumstance can be adduced, than that it is a common day's work, on fallow land, for four steers to plough two acres with a double-furrow plough, and that a general use is thus made of them, and for most of the other purposes of draught in the county where they were originally found; and in others to which they have been since transplanted.

The rules generally pursued in breeding and raising this va-



parior, but called (provincially) the higher side, a cellar; and dairy-room, but these latter are frequently under a lean-to roof; the rooms very low, not ceiled, and two bed-chambers over; the floors of the chambers are of oak plank; the ground-floor, earth, lime-ash, or flag-stone.

The farm-offices built of the same materials, consisting of a barn, cow and ox sheds and hog-sties, stand in confusion about the dwelling. The intervening and circumjacent ground is called the farmer's town-place; for as to that essential appendage, a regular farm-yard, it is a convenience not often met with in any part of the county.

Some good new farmhouses erected centrally on newly inclosed lands. One for forty-six acres has a very neat elevation, (fig. 802.)



and the plan (fig. 803.) contains a feeding place, into which the turnips are carried (the cart being backed into it), and from whence the sheep and oxen are fed (a); place for a yoke of oxen (c), either for soiling or winter-feeding; the oxen are tied to posts (c); there are troughs for turnips (d); cribs, or racks for hay or straw (e); lean-to for store sheep (f); lean-to, in which half a score sheep are kept to fatten, the number being completed again as soon as any are sold (g); fodder house, used as a barn (h); open shed for tools (i); hanging doors with bolt in side, and through which the fodder is handed to supply the cattle, and is thus kept always dry (k); door and staircase leading up to the wool-chamber (l). The stairs rise quick so as to be quite out of the way of the ox feeding in that side of the house.

Cottages. "I had occasion often, in my dreary walks, during my survey, to take shelter in some of these miserable dwellings, and found the poor inhabitants busy in placing their bowls, crocks, and pans, to catch the waters pouring in at the roof. However, the meanest cottage generally has that great source of comfort, a garden, attached to it." Some very comfortable

plans of cottages by Capt. Penson, of Eithy, are described by the surveyor.

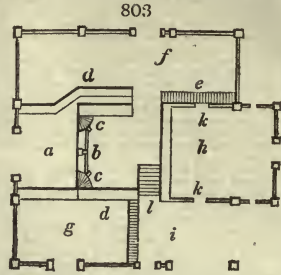

4. Occupation.

Farms from three or four to three or four hundred acres, mostly from thirty to fifty pounds a year. Leases on rack-rented farms generally from fourteen to twenty-one years.

5. Implements.

No country affords a greater variety of wheel and other carriages. The harvest waggon (fig. 804.) has a lade before and

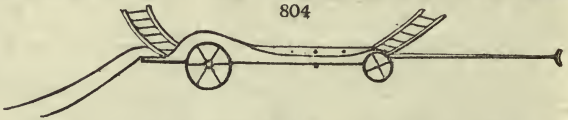

behind, and is open in the middle; it carries about 500 sheaves of corn. When drawn by horses shafts are applied; when by oxen, a pole. An arch of boards over the hind wheels prevents the corn from bearing on them.

The wain is another light useful carriage for carrying corn and hay; it consists of a light open long body, borne upon two wheels; a railed arch over the wheels prevents the load from bearing upon them; it will carry from 200 to 250 sheaves, which are secured by ropes, it having no sides or lades.

A sledge for corn, hay, or faggots (fig. 805 a.); slide butt (b); quarry butt for earth or stones (c); dung-pots or dung-panniers (d) for dung or stones; and panniers with hooks for faggot wood and sheafed corn (e) are also in use.

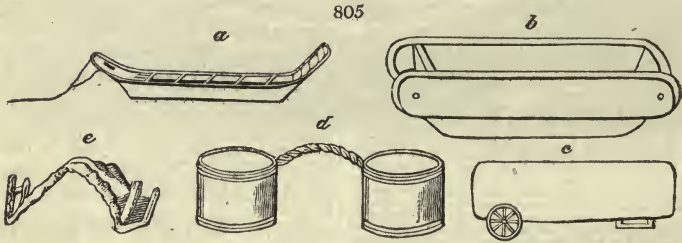

Box hand barrows and grass barrows (fig. 806.) are also used on a few farms.

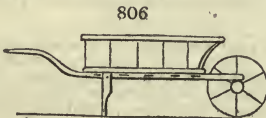

The Cornish plough is a small swing plough with a straight piece of wood as a mould board.

Barn boards for threshing on are four or five planks laid across beams, but about one third of an inch asunder, so that the corn as it is threshed may fall through and not be bruised. In some places, wheat is separated from the straw by beating it on a barrel or inclined plane, usually by women. Fences generally made of stone, or raised banks of stone, slate, and earth sometimes planked.

6. Arable Land.

The pilez, or naked out, cultivated on worn-out ground; its straw very fine, and reckoned nearly as good as hay. A quantity of potatoes exported yearly; but not enough of wheat given for home consumption.

7. Grass.

Chiefly near towns and villages on sheltered slopes, and the uncultivated lands known as moors, downs, crofts, and wastes; some meadows watered.

8. Gardens.

Common to cottages and farms, and better attended to than in most counties; orchards also attached to many farms.

9. Woods and Plantations not abundant.

10. Improvements.

Draining practised to a considerable extent, and one or two examples of embanking.

The maritime situation of Cornwall presents the farmer with three valuable manures, fish, sea-sand, sea-weed. In some years the farmers who live in the vicinity of fishing towns, have an opportunity of buying the bruised and small pilchards; which being deemed unfit for market are rejected, and called "coff;" four cartloads of twelve bushels, are considered as the proper quantity for an acre. The usual mode of management is to bury the coff in a pile of earth, deep enough to secure it from dogs and hogs, adding to the pile a sufficient quantity of sand; well mixing and turning all together, after having lain some months. Without this practice, the fish would not decay sufficiently for perhaps a year or two. The fish are sometimes used alone; they are then spread thinly over the ground before the plough, and turned under furrow. One pilchard cut up small, will amply dress one square foot of ground.

The old salt which has been used to cure the pilchard, and judged to be no longer fit for that purpose, is advantageously applied for a barley or a turnip crop; twenty to thirty bushels per acre. It is commonly hand sown, in the manner of corn; and it should remain on the land five or six days before the seed is sown. It is best adapted to light lands, particularly furze crops. Twenty bushels per acre have been strewed over grass lands, and over a wheat crop, in the month of March, with evident advantage.

Another article of manure obtained from this useful fish is the liquor which drains from it while under the process of curing, consisting of blood, brine, and some oil which escapes, and which is caught in pits; the diligent farmer carts this away in casks, for the purpose of pouring over and mixing with his piles of earth and sand, which it greatly enriches.

11. Live Stock.

Devonshire cattle prevail, but it is only among the more enlightened and spirited breeders that the genuine North Devon are to be met with. Cows are kept in winter in sheds open to

the south; one of which for seven cows and a fattening calf (fig. 807.), described by the surveyor, contains cribs for hay or straw in winter, and lucern, vetches, &c. in summer (a); troughs for turnips, potatoes, cabbages, &c. (b); beds or platforms for the cows to stand and lie on (c); gutters sunk two or three inches to receive the dung (d); head-way and feeding place (e); dark place for fattening a calf (f); the division outside (g) for a cow that has, or is near having, a calf. She is not tied up.

807

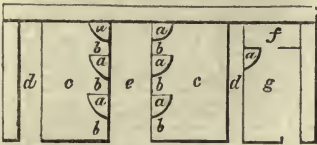

7040. The islands of JERSEY, GUERNSEY, ALDERNEY, and SARK, which lie in the Bay of St. Michel, and form the remnant of the ancient Duchy of Normandy, though naturally belonging to the continent of France, yet, for nine centuries have been subject to the British Government. The agriculture of all of them is nearly the same; but we shall follow the Reporter to the Board of Agriculture in considering first, that of Jersey, and next Guernsey. These islands are chiefly remarkable for their breed of cattle, their parsneps, and the degree of perfection to which many plants arrive in the open air, which are kept in England under glass. (*Quayle's General View, &c. of the Norman Islands, 1812.*)

7041. Jersey, 39,580 acres of warm and rather moist climate, diversified soil, and features; the soil is for the most part light, on granite or schistus, and there is some peat and marsh. No calcareous soil or rocks; granite and gneiss quarries worked; and granite pillars of fifteen feet in length extracted. Water abounds; and belief is still entertained in the efficacy of the diving rod for discovering springs.

1. Property.

Minutely divided, and mostly in the hands of a resident yeomanry. Some singular laws and customs as to tenures, as for example, the *retrait lignager*, and *retrait seigneurial ou fudal*; also the legitimation of children not born in wedlock, by the marriage of their parents, as in Scotland, and most other countries of Europe excepting England.

2. Buildings.

Those of all classes substantially built of stone, sometimes rough cast, neatly lined in imitation of squared stone work. Farm-houses generally covered with thatch or pantiles. Cottages generally of stone, with a vine in front.

3. Occupation.

Farms small, and fields diminutive; farmers frugal, and their wives good managers and industrious.

4. Implements.

Plough with wheels, resembling that of Hampshire; sometimes drawn by two bullocks, and six or eight horses; a sort of large plough used for ploughing deep, for parsneps, and held in partnership by several farmers; instances of this plough being drawn by six oxen, and sixteen horses. (p. 64.)

5. Enclosing.

Fields very small and irregularly shaped, and the fences of high earthen mounds, often twelve feet wide at least, and six feet high, crowned with a hedge, or timber trees and pollards.

6. Arable Land.

Soil deep, and deep ploughing generally practised, but no improvement in it for ages; no naked fallows. The spelt wheat (*Triticum spelta*), here called *tremaise frumentum trimetre*, here enters into rotation; it is sown in February, produces short stiff straw, is difficult to thresh, but never lodges.

*Parsneps* are grown by every farmer, and either by the spade culture alone, by the plough and spade, or by the small and great plough; any soil in good heart and tilth suits them, but peculiarly, a deep loam; and in the same spot, generally are raised beans, pease, cabbage, and occasionally potatoes.

When the ploughing or digging is completed, the field is once harrowed; straight lines are then drawn across, by means of a gardener's rake, usually from north to south; women then proceed with dibbles, and set the beans in rows, at a distance of four inches, or five inches from bean to bean; in four, three, and sometimes in two ranks of beans, leaving intervals of between five and six feet, between each of the sown rows. In the use of the dibble and in dropping the beans, the women have acquired considerable dexterity. In many instances, they are followed by children, who drop into each hole made by the dibble, after the bean, three or four pease; the parsnep seed is then sown, at the rate of one-third to one-sixth of a bushel to the acre.

The parsnep, not usually relished elsewhere as an article of human food, is here consumed by all classes of people; it is eaten with meat, with milk, and with butter; but not, as is the common mode of using it as human food in England, with salt fish; or as in Ireland, together with potatoes.

The next most valuable application of this root is hog-feeding; at first it is given to the animal in a raw state, afterwards boiled or steamed, and finally, for a week or a fortnight with bean and oatmeal. A hog, treated in this way, is sufficiently fattened for killing in about six weeks. Its flesh is held superior to that arising from any other food, and does not waste in boiling.

*Bullocks* are also fattened with parsneps, in about three months; their flesh is here considered of superior flavor to any other beef, and commands, on that account, an additional half-penny in the pound on the price. To milk-cows they are also usually given; on this diet the cream assumes a yellow colour; by the accounts here given, it appears, in proportion to the milk, to be more abundant, than when the animal is kept on any other food whatever. When the cow receives at the rate of thirty-five pounds per day with hay, seven quarts, ale measure, of the milk produces seventeen ounces of butter. It is generally allowed, that the flavor of the butter is superior to any other produced in winter.

*Geese* are sometimes shut up with the hogs, to fatten on parsneps, which they will eat raw. The root is also given boiled; and for a week before killing, they are fed with oats or barley only. Horses eat this root greedily; but in this

The cows are tied to posts by means of a strong chain and rope, which by means of a ring runs on a long staple.

Oxen very generally work both in plough and cart; and in brakes, and yoked in the bow.

Sheep a mixed breed; Cornish breed lost among crosses.

Horses a small hardy active breed, well adapted to the hilly nature of the county.

Cornish hog always white, long-sided, razor-backed animal; crossing by the Devon, Suffolk, and Leicester breed, has taken off length and sharpness, and added breadth and depth; a mixture of Chinese and Suffolk is another variety.

12. Political Economy.

Public roads tolerably good; lanes bad. Some travellers who met Pargan the reporter, hoped he would notice with reprehension, the straw-traps that the farmers lay in some of the cross-roads, and which, concealing the deep ruts, endanger their horses, gigs, and their own necks.

Manufactures few; some of woollen, carpets, and paper. The three great staple commodities for export, are tin, fish, and copper, the moor-stone, China stone for porcelain, barley, oats, potatoes, and some wheat.

island it is never given them, as it is alleged, that when on this food, their eyes are injured. About Morlais, horses are not only ordinarily fed on parsneps, but they are considered as the best of all food, superior even to oats.

Lucern a good deal cultivated, and found productive. Hops to a moderate extent; the reporter could not find that the tincture scordonia was employed as a substitute, as related in some botanical works. A species of cyprus (most likely *carex arvensis*), used for twisting into halters and other ropes.

7. Grass Lands.

Of very limited extent, but meadows very productive.

8. Gardens and Orchards.

Very productive, and in general carefully attended to. Chaumontelle pears brought to great perfection, and with grapes, bulbs of the Guernsey Lily, parsnep seed, and some flower seeds, sent to the London fruiterers and seedsmen.

Orchards generally attached to all farms. Jersey cider in much esteem, and a principal article of export. Most of the farm-houses have large arched doors, made up in purpose for the passage of cider casks. A valuable work on the subject of cider by the Rev. F. Le Conteur, entitled *Apercu sur la culture des Pommes, Jersey, 1806.* The pomeri, lamme, noir-toit, and gros-arm, the cider-apples at present in vogue.

9. Woods and Plantations.

Very limited extent, and the waste ground a little more so; only about 300 acres of rocky summits of hills; these might be planted.

10. Improvements.

No calcareous manures found on any of the Norman islands. Sea shells tried on clay with great advantage; and sea weeds (*urvic whence track*). Irrigation in a simple manner, practised in the narrow valleys from time immemorial. Sea encroaching in some places, and jetties and embankments proposed, but nothing done.

11. Live Stock.

Alderney cattle well known. Though there can be no doubt that the breed was derived from the contiguous continental coast, yet it is not known that in any part of it at present, the same breed is preserved in equal purity. Next, perhaps, to the possession of *urvic*, the treasure highest in a Jersey-man's estimation, is his cow. She seems to be a constant object of his thoughts and attention: that attention she certainly deserves, but she absorbs it too exclusively; his horse he treats unkindly; his sheep most barbarously; but on this idolized cow, his affections are riveted as firmly as those of an eastern Bramin on the same animal. It is true that in summer she must submit to be staked to the ground; but five and six times in the day her station is shifted. In winter she is warmly housed by night, and fed with the precious parsnep. When she calves she is regaled with toast, and with the nectar of the island, cider, to which powdered ginger is added. Could she be prevailed upon to participate in all her master's tastes, there is no doubt but that he would willingly bestow on her the quietness of *urvic itself*.

To guard the purity of her genealogy, and to prevent others from being conveyed to England, under the semblance of Jersey cows, he has invoked the interference of the insular legislature. On the 8th of August, 1789, an act of the States passed, by which the importation into Jersey of cow, heifer, calf, or bull, is prohibited under the penalty of 200 livres, with the forfeiture of boat and tackle. A fine of fifty livres is also imposed on every sailor on board, who does not inform of the attempt. The offending animal is to be slaughtered, without mercy on the spot, and its flesh distributed among the poor. The same act of the States directs, that when cattle of the enumerated descriptions are exported, a certificate of their being natives of the island is to accompany them. On the vessel's return, another certificate is required, that the same identical number, and no more, have been landed.

If there is indeed, at present, little danger of the occurrence of that which Jersey-men so much deprecate, for he will not speedily become a convert to any heretical opinions which he may happen to hear from an Englishman; for in this, as in every thing else, it may be observed, that the rooted opinions of a people are more powerful than any law.

The oxen are distinguished by rising to a stature and bulk

much superior to the female. Persons who have not seen any other than Alderney cows, would be surprised to witness the size attained by some oxen of the same breed, which may be seen in the Jersey carts.

The object of the dairy is butter: the cows are milked three or four times a day during the rest of the year; the milk is kept in glazed earthen-ware dishes till it throws up the cream, which is separated, kept five or six days, and then churned by itself. The prime milkers are not generally exported. After the young cow has borne a calf or two, it is sometimes significantly remarked, "qu'elle est bonne pour l'Angleterre;" and she goes to the cow-jobber.

As to the merits of the Jersey cows the reporter observes, if the palm can be contested with them by any, it will be by a breed little known in the south, the Dunlop (in Ayrshire) cattle, a cross between the short-horned and the Alderney.

Sheep a bad shouldered coarse boned breed, small horned, and between a black and brown color; largest flock in the island forty: weight of carcass fifty pounds; in the winter many perish from want, and many by dogs.

Horses a hardy small breed, very ill treated.

Swine, white, long-legged, flap-eared.

Geese are plucked alive, when the feathers drop, as an article

7042. *Guernsey.* A rocky hilly surface, of which 8000 acres are under cultivation; a climate rather moister than that of Jersey, and the soil generally light, on granite, gneiss, or schistus. The operative classes resemble those of England more than those of Jersey.

*Agriculture* much the same as in Jersey; Guernsey figs much esteemed. Some land embanked and sold with permission of government, and the produce applied to improving the roads.

*Live Stock.* Guernsey cattle are larger-boned, taller, in every respect more stout and coarsely made than those of Jersey. The front is wide, horns divergent and thick, but not long; never with the graceful short curve observed in some Jersey cattle, and in the short-horned breed. The dewlap is also coarse and pendant. They are deep-chested, and the carcass, compared with their neighbors', more bulky. Their coat is also not so fine; and the colors, though varying as in Jersey, on the whole appear more dark. Some, but not so many, are found cream-colored, and the breed may safely be pronounced more stout and hardy. In one respect, a similarity appears in the best milkers in each island: these are observed to have a yellow circle round the eye; the hide yellowish; and in particular, the skin of the tail at its extremity appears of a deep yellow, approaching an orange color. The same circumstance has been since observed to exist in good milkers of other breeds; but in Guernsey at least, on examination, this yellowness is general and striking. The butter produced by the milk of each breed is also naturally of a rich yellow color.

As to the question of superiority between the cattle of either island, it is settled most decidedly by the inhabitants of each, as may be supposed, in their own favor. The people of Jersey have gone furthest in support of their opinion. By the third

of economy, and also to prevent the grazing-ground being injured. It is also thought a relief to the animal.

*Pigeons.* Here, as in France, the *Droit de Colombier* is attached to certain residences; but not exclusively, as appeared to be the case in France, to those held by a noble tenure.

*Bees.* The flavor of Jersey honey highly vaunted, probably from the numerous flowering plants, legumes, fruit trees, garden plants left to seed, &c.

10. *Political Economy.*

Roads numerous, narrow winding, crossing each other, and consequently intricate; flanked by high earthen fences over-canoed by trees. In rainy weather they are canals of mud. Two carts meeting each other on the *chemin du roi*, could not pass; one or the other must back till it reached the nearest field; gateway, or some other recess, to which it might retreat, during the passage of the other. To this little circumstance in their internal economy, and the disputes which it engendered, may, perhaps, in part, be attributed the remarkable proficiency of the Jersey populace in swearing.

*Manufactures* few: some boots, shoes, and cordage exported: an active fishery to the east of the island. English law as to poor rates exists; but as the poor are few, it is not necessary to act on it. Dialists of Jersey a corrupted French, and a bad English.

section of their law, of 1789, respecting cattle, they expressly apply "aux îles voisines," the same penalties and restriction on importation of cows, heifers, and bulls, as on importation from any other quarter. Into Guernsey, where no similar restrictions exist, Jersey cows have occasionally been imported. The comparison between cows of each breed, as milkers, leads to that result which, in the place where it is made, might be anticipated.

Next it may be noticed, that though the exportation of Guernsey cows, compared with that of the same animals in Jersey, is not extensive, yet that their price in Guernsey is higher. One was noticed for which a farmer had offered a price of thirty guineas, for his own use; and the offer refused. As to the quality of the butter also, in each island, it may be observed, that the preference is usually given to that of Guernsey. In this article indeed, in some degree the difference may arise from their different practices in the process of churning. The cream is here left unskimmed, till the milk becomes coagulated: on the third day milk and cream are churned together. As little attention has yet been given to the improvement of the breed of cattle, as in Jersey.

*Roads.* Improved under the government of Sir John Doyle. Bricks and tiles manufactured, and some spirits, which formerly found its way into England, under the name of French brandy.

## SECT. II. Agricultural Survey of Wales.

7043. A hilly mountainous surface of 5,206,900 acres, with a climate colder than that of England, and more moist in the proportion of thirty-four, the average number of the inches of rain which falls in Wales, to twenty-two, the number for England. The soil is generally of an inferior description, and the great proportion of mountainous surface is fit only for pasturage and planting. Little exertion was made in cultivation till the middle of the eighteenth century: from that period to the present, agriculture has been gradually improving. A general view of it, as in 1809, has been published by the Rev. W. Davis, of Montgomeryshire, whose work we shall adopt as our guide.

7044. **NORTH WALES.** 1,974,510 acres, chiefly of mountainous surface, in six counties, including the Isle of Anglesea. The climate humid and cold in elevated situations, but warmer in the vales and near the sea. The soil moory, coarse, clayey, and otherwise unfavorable in most places, excepting in the vales on the banks of streams. Minerals chiefly copper, lead, and iron. The famous Mona and Paris Copper Mines in Anglesea, have been worked since 1768; lead is chiefly worked in Flintshire. Excellent slate is found in various parts of Caernarvonshire, and worked to a great extent, especially on Lord Penrhyn's estate. Marble is worked in Anglesea, and limestone, freestone, and other stones and minerals abound in different places.

### 1. Property.

Estates from thirty shillings to 30,000*l.* The effect of the custom of gavelkind, which obtained all over Wales, was a too minute division of property. Equality and poverty went hand in hand. But when the custom was abolished, and alienation permitted, an accumulation of property was the necessary consequence, which became very prevalent in the two last centuries: and having arrived at its maximum early in the eighteenth century, it has, since that period, shown some instances of retrogradation: but subdivision and accumulation of estates will naturally fluctuate. Here are no petty lairds or tacksmen, as in Scotland and Ireland.

Gentlemen of moderate income, and residing in the country, transact the affairs of their own estates. These of greater property commit the whole care of rents, repairs, and contracts of sale or purchase, to the management of agents; who, in general, are persons well qualified for the undertaking, brought up solely to the business, and make it a point of honor and integrity to do justice to the landlord, and a point of conscience not to oppress the tenant. These agents, however, by their own indiscretion and rapacity destroyed the very *raison d'être* of litigation in the people, necessarily diminished the number of their successors.

Only two copyhold tenements have been noticed in the whole district. All the other estates are held either mediately or immediately in *capite* of the King, by a kind of mixed tenure, be-

tween the feudal and allodial, going under the common appellation of freehold.

### 2. Buildings.

Some fine castles, as Powys, Penrhyn, and Chirk. Of farm-eries, about seven in ten are in a very wretched state; good new ones in Anglesea, and Caernarvonshire, Flintshire, and Merionethshire.

*Cottages!* in these and other counties are truly the habitations of wretchedness. One smoky earth, for it should not be styled a kitchen; and one damp litter-cell, for it cannot be called a bed-room, are frequently all the space allotted to a laborer, his wife, and four or five children. The consequences are obvious; filth, disease, and, frequently, premature death: as they would be more obvious, had not these evils an almost unsubsidiary vicar of constitution to encounter. Three-fourths of the victims of the putrid fever, perish in the mephitic air of these dwellings. However, in some parts, especially near lime works, mines, collieries, &c. the example of one neat cottager is followed by others. Here, their dwellings are frequently white-washed; their children are industrious in collecting road manure, which is preserved within circles of loose stones, for the use of their gardens. These minute, though trifling, are worthy of record, as they are descriptive of their general character.

Some exceptions in different places, and especially on Lord Penrhyn's estate. The reporter gives an excellent plan of a

cottage for a cottage farm, and also plans of farms of different sizes, adapted to such cottages.  
The cottage farm house (fig. 808) contains a kitchen (a), bed-

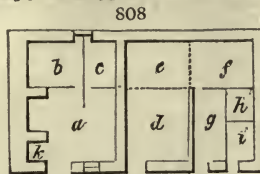

room or parlor (b), pantry (c), barn-floor (d), two bays (e and f), cowhouse (g), calving place and calf house (h), pigsty (i), and stairs (k) to garret and bedrooms.

A cottage farm for the same house, and nine acres of land, contains seven small enclosures (fig. 809 a), including the garden. One for six acres, contains six enclosures (b) including the garden.



3. Occupation.

Largest farm of cultivable land about 600 acres, on the mountains 1000 acres and upwards, at one shilling, or one shilling and sixpence per acre: size on the increase, and admitted to be favorable to wealth by the proprietor, who adds yet that wealth should be valued, not in proportion to its national aggregate, or quantity in the abstract, but as it is widely and generally diffused. An analogy exists between monopoly in all its forms, and a macrocephalous constitution, which never can possess the energy of a body symmetrically proportionate.

Farmers, properly so called, are, as we may naturally expect them to be, rather too tenacious of old customs. It is, however, illiberal to charge them with obstinacy, in delaying the adoption of pretended improvements; for, as it is not all gold that glitters, neither is one half of the patent implements, and machines, or one-tenth of the writings of visionary theorists, better than lumber and trash; for which the farmer should not throw away his hard-earned money, before they are put to the test of experience, by those who have opulence enough to bear disappointment; and who, from the advantage of superior education, may be better qualified to form a judgment of the probable effects. Show the farmers their true interest, and, in general, their minds are as open to conviction, and as susceptible to reason, as any other class of men whatever.

Leases out of repute. It cannot be denied that leases have done good in Scotland. We are, therefore, driven to the necessity of supposing, that the Scotch and Welsh tenantry are very different kinds of beings. The circumstance that renders the Welsh leases ineffectual, is the want of capital; and what enhances the evil of this want is, the ignorance of many farmers in the right application of what small capital they have. By tilling too many acres, they, as well as the public, suffer loss in every acre. Many a farmer, who has means barely sufficient to manage a farm of 500, a year, tolerably well, thinks a farm under 1000, or 1500, beneath his notice; and granting a leasee to such a tenant, who has not one-fourth of the capital requisite to carry on improvements, would be preposterous.

Lord Penrhyn executed draining, fences, roads, and all improvements requested by his tenants, and approved of by his agents, at five pounds per cent. on their amount added to the rent.

4. Implements.

The original Welsh plough, a clumsy wooden fabric, still in use in Caernarvonshire, and a few places in other counties; about 1660, Lamma's variety of the Kotheram introduced, and now common; Scotch plough now generally known and approved; and the other improved implements tried by the amateurs.

5. Arable Land.

That farmers convert too much of the lands which were formerly in tillage, into pasture, is but a groundless cause of alarm. Farmers should, and always will, consult their own interests; and whether the conversion of their lands into tillage or into pasture be found the most profitable to themselves, the same will eventually be found most beneficial also to the public.

The corn raised in North Wales not equal to its consumption; falls general and defended as necessary. In Anglesea, a rotation of five white crops in succession; most of them barely return the expense. Very little wheat grown, main corn-crop oats, and next barley. Scarcely any flax or hemp grown; potatoes beginning to become a general crop. On the whole, the management of arable land wretched, excepting by the amateurs or proprietors.

6. Grass.

Land well adapted for tillage; is commonly left too long in pasture; and by which neglect it becomes mossy, and in some instances covered with ant-hills. It has been said of some meadow-lands in Wales, that a man may mow in them all day, and carry home his day's work at night. This may appear hyperbolic; but it is so far true, that in some meadows the mark of the swath never disappears; and a mower may be certain of having followed the same line, to a half-inch width, for twenty or any number of years back. In such meadows, the trouble of raking the hay together is the great work of harvest.

In the eastern parts of the counties of Denbigh, Flint, and Montgomery, consisting of the most fertile vales, the principal

object of the farmers is to convert their hay and grass, as much as much as possible, into butter and cheese.

In the hilly parts of the afore-named counties, and in Anglesea, Caernarvon, and Merionydd, their peculiar province is to rear cattle, to be sold lean to the graziers of other districts. There are but a few acres of land that will fatten cattle; the vales of the Severn and Vyrrow in Monmouthshire, the banks of the Dee in Flintshire, and the vale of the Clwyd in Denbighshire, are the principal places where the pastures afford sufficient nutriment for that purpose.

7. Gardens.

Much wanted for the cottagers, especially in Caernarvon and Merionethshire. Too many poor cottagers have not as much as a leek or a potato, except what they either beg or buy. In the greater part of the district, the planting of orchards would be thought a very wrong application of the soil. On the borders of England are some orchards; and in plentiful years, a few farmers make either cider or perry for their own beverage.

8. Woods.

Have been abundant in former times, especially in Anglesea; now very scarce there and in Caernarvonshire; more in Denbighshire, especially round Chirk Castle, Wynnstay, Erthing, Vale of Clwyd, &c. Extensive young plantations made in these counties, especially at Wynnstay and Lord Penrhyn's, Anglesea, Denbighshire, and much timber, wood lands, and plantations in Montgomeryshire, which will long be the best wooded county in North Wales. Proprietors planting upon a large scale, and not raising trees from seed in their own nurseries, formerly used to procure seedlings of larch, firs, and pines, &c. from Scotland; but owing to their heating in close bundles, and otherwise damaging upon the road, not above one-eighth, the number, could be expected to grow. They are now more given to encourage nurserymen at home, and nurseries are accordingly established in different parts of the district. "One and two-year-old seedlings of all sorts of forest trees, nearly as cheap as in Scotland, reckoning carriage, and one thousand seedlings, distance of carriage, and length of time, are considered by Williams, and other nurserymen, ensure trees of their own growth and planting for a number of years."

9. Improvements.

A marsh of 5000 acres in the southern corner of the island of Anglesea attempted to be embanked in 1790. The embankment was brought forward from both sides at the same time, and was intended to be joined in the middle of the marsh, where the force of the tide was greatest: when within about twenty rods of a complete junction, owing to some of the proprietors withholding their dividends, the work was deserted, after expending nearly 12,000*l.* and when a few pounds more would have completed the whole, as the materials were already carried on the spot. On the 25th of January, 1796, an uncommonly high tide added twenty rods more to the breach, in which state it now lies. The bank was made of furze fagots, bound with double cordage, covered with sand, then with sods, and on the sea-side with a stone pavement, eighteen inches deep at the top, and diminishing to nine inches at the bottom. It was fifty-one yards wide at the base, four yards at the summit, and five yards high; the slope of the sea-side to that of the land-side, as seven to four.

The embankment and improvement of Traeth-Mawr and Traeth-Brychan sands, between Caernarvon and Merionethshires, have been above 170 years in contemplation, and never yet performed. In 1625, Sir John Wynne, of Gwydir, intended to have brought over Sir Hugh Middleton, the celebrated engineer, to undertake the work; but no materials were wed, save ink and paper. In the year 1710, the Dutch adventurer made a proposal to the proprietors, but to no effect. In 1770, the late Bell Lloyd, Esq., who was always active in works of public utility, and others, brought the subject afresh under consideration; at the same time proposing a nearer road from London to Dublin, across the Traeth-Mawr sands, when embanked. Golborne, the engineer, was sent down by the Duke of Ancestar, and two estimates were made. The late Dr. Worthington was peculiarly active in forwarding the work. It has gone so far as to procure subscriptions to the amount of 29,000*l.* and upwards, when the whole scheme was frustrated by the mean spirit and refractoriness of some neighboring proprietors.

In 1809, W. A. Madocks, Esq. M. P. having a considerable estate on the Caernarvonshire side, and having there embanked Penmorva marsh with great profit (fig. 510 a) and founded the company of (1804, 17), commenced embanking the sands of Traeth-Mawr (c), by carrying out from both shores an immense bank (d) of stony materials deposited and left to find their own slope by the washing of the tides. The two banks were within less than a furlong of being joined in the middle; but owing to the force of the tides, and the embankments of the very spirited proprietor, it was never completed.

The River Dee Company, established by Act of Parliament in 1740; by several embankments made in the years 1754, 1765, 1769, and 1790, on the river Dee, in Flintshire, to keep out the tide and land-floods, they have been enabled to gain 3100 acres, which are now covered with good crops of corn, of lucern, and of artificial grasses; and the whole redeemed waste is incorporated into a township, bearing the very appropriate name of Sealand.

In various parts of the coast of Anglesea, and the other maritime counties of North Wales, there is still much to be done by embanking. Caernarvonshire has been eminently fortunate in the acquisition of W. A. Madocks among its leading improvers. Indeed, his improvements are of such magnitude and variety, designed with such taste, and executed with such facility, that a minute report of them would appear, to those who have not personally visited the place, more like the reverend romance, than the plain and genuine description. In harbors, embankments, canals, buildings, roads, plantations, and rural and commercial improvements in general, nothing less than a *Tre Madoc Guide* pamphlet can do justice to the founder."

10. Live Stock.

Cattle and cocker the staple exports of Anglesea. When numerous herds are bought in the island for the English markets, they are compelled to swim in droves across the strait of

the Menai; and although numbers of the weaker sort are sometimes swept down by the force of the current for some miles, yet losses seldom or never happen. A chain bridge is now erecting across this strait.

The characteristics of a choice Angleseax, must agree in most points with those of a Roman one, as described by Columella: coal-black color, with white appendages; remarkably broad ribs; high and wide hips; deep chest; large dewlap; flat

810

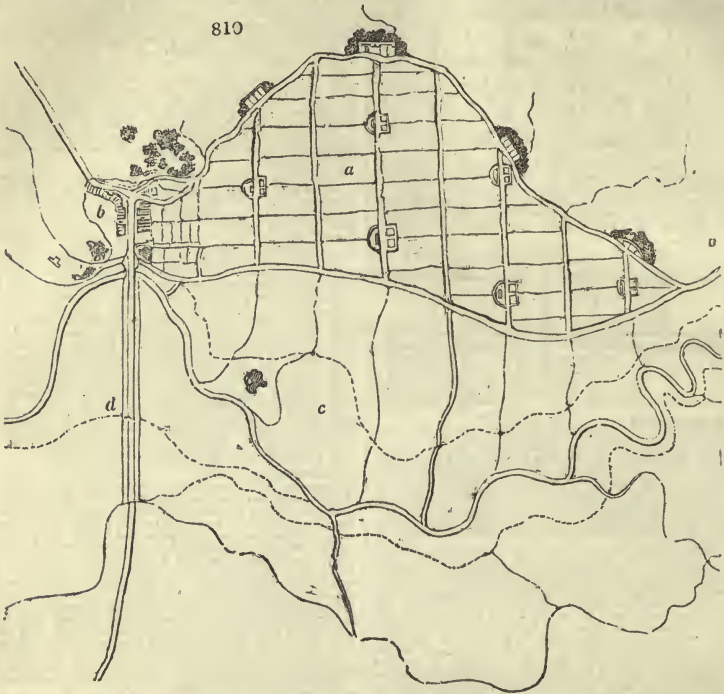

face; and long horns, turning upwards. Bakewell thought, that in some points they were nearer his idea of perfection in shape, than any other he ever saw; his own improved breed excepted. Some farmers aspiring at a select stock, by having their he-calves gelt under their dams, their horns become of a yellower color, longer, and finer than common; and, upon the whole, nearer the present idea of symmetry. The average weight of their quarters, when fat, at three or four years old, is from eight to eleven score pounds.

The promontory of Lley and Eviynydd, in Caernarvonshire, having the same kind of undulated surface, though not altogether so good a soil as Anglesea, has likewise a breed of cattle similar in several of their characteristics.

The cattle in the remaining part of Caernarvonshire, and in the whole of the county of Merionydd, some few select stocks excepted, seem to be diminutives of the above breeds of Anglesea, Lley, and Eviynydd; having nothing to recommend them, save their extreme hardiness, and consequent cheapness of rearing. The highlands of the counties of Denbigh and Montgomery abound with the same puny race. In the vales, and in the county of Flint, the cattle are of a superior kind, larger, and of all varieties of colors. The natives of the sea-coast from Abergeir to Holywell, and thence along the Dee towards Cheshire, are reckoned very quick feeders.

Neither good butter nor cheese are made in North Wales by ordinary farmers.

**Sheep.** The largest of the native breeds, is that of Anglesea; they have white legs and faces, and are generally without horns.

The second kind of sheep in North Wales, is that peculiar to the mountains. They have generally white faces and legs; some have horns, and others none. The smaller sort of them weigh from seven to nine pounds per quarter; and give wool from three quarter of a pound, to one pound and a half.

The third kind is peculiar to the Kerry hills in Montgomeryshire; being, perhaps, the only species in North Wales, which produce perfect wool: that of every other Welsh breed being more or less mixed with coarse long hairs, called by the manufacturers kemps, making the articles in which they appear, of much less value. The characteristics of this breed are, large woolly cheeks, white bunchy foreheads, white legs covered with wool; no horns, and a broad beaver-like tail. They are very hardy, and comparatively tame; being not so much disposed to ramble as most other wild sheep. In shape, however, they are far short of compact symmetry; and were this defect improved by the care and attention of the farmers, the breed would be worthy of being universally adopted throughout the principality. They weigh, when fat, from ten to fourteen pounds per quarter. The average of wool, including the whole flock, is ten stone, of fifteen pounds each, from every 100 sheep.

The fourth kind is the black faced, and fine woolled sheep, bred on the Long Mountain, near Welsh Pool; and on other

hills, on the borders of England, in a line from thence to Wrexham.

The flavor of the mutton of the sheep feeding upon the Llanymynech and Porthywaen lime-rocks, is reckoned very delicious, by the nice palated pupils of the epicurean school; and their wool is as fine as any in England; that of the Ryeland breed, perhaps, excepted. A person in travelling through the country, may observe several other kinds of sheep; being crosses from some or other of the above four distinct breeds; but they are in general the offspring of chance and instinct, without being directed by any choice or system.

The Merinos with their different crosses; and the Leicester, Downs, and others, bred by amateurs.

**Horses.** In Anglesea, for want of fences, the horses, as well as the sheep, are commonly fettered. Were colts of the best shaped breed in existence, thus fettered as soon as they are weaned from their dams, and the practice used from generation to generation, their natural gait and shape must necessarily be changed, at length, into awkwardness and deformity. Few English stallions have as yet been introduced into the island; and those that have, do not appear to have done much towards improving the native breed.

In the county of Merionydd, and the hilly parts of Montgomeryshire, great numbers of ponies, commonly called merlins, are reared. They are exceedingly hardy, having, during winter as well as summer, only the range of the hills; from whence they are never brought down until they are three years old, and fit for sale. What has tended to, and will in time destroy the shape and good qualities of this hardy race, is, that in the propagation of their species they are left entirely to chance and instinct.

They are driven from the hills to fairs, like flocks of wild sheep; and the place of sale exhibits, in some degree, an amphitheatre, where manhood and ponyhood strive for the victory. When a chapman has fixed upon his choice at a distance, the wrestler, being generally the seller's servant, rushes into the midst of the herd, and seizes the selected animal; which, never before touched by human hand, struggles with all its might to extricate itself; and in some particular situations, both have tumbled topsy-turvy from the summit of a steep hill down into a river beneath; the biped still continuing his grasp, and the quadruped disdaining tamely to submit.

Another breed, somewhat larger than these, and probably raised by a series of crossing between the English and the natives, are hardy, handsome, and exceedingly active. Some of them are too small for the team; but for the road, under moderate weight, they have no rivals. "They will ascend and descend our mountainous staircases" with the greatest agility; and without giving their riders, who have more fool-hardiness than humanity, the trouble of alighting. The larger kind of them is exceedingly well adapted for the team, on small or steep mountainous farms; where the great strength and sluggishness of the heavy kind of horses would be egregiously misapplied.



The vales of Montgomeryshire have long been noted for an excellent breed. Some attribute this superiority to a stud of horses kept by Queen Elizabeth, at Park, near Caer Sws, in the Severn vale; and to others brought into this part of the country from Spain, by Robert, Earl of Shrewsbury.

Gentlemen, in most parts of the district, and farmers in the vales of the three counties bordering on England, have for some time furnished themselves with excellent draught horses, both for the coach and the wagon; which, when the markets are open, are sold in great numbers. They are generally either black or bay; strong, active, well made, and measure from fifteen to sixteen hands high.

A custom very injurious to the growth, strength, and soundness of horses, prevails over the greatest part of the six counties, that is, working them too young; when their bones have not attained firmness from their cartilaginous state, nor their power of elasticity, contraction, and extension, which is necessary to endure exertion and labor. Instances have, however, occurred, of horses being worked from two to twenty years old, without any apparent detriment, saving a diminution of their natural size.

"The predilection which farmers manifest in favor of horse teams, may, in time, reduce the nation to the dilemma of enacting a law to repeal the Mosaic, and enjoin the flesh estate."

Tender furze, bruised with mallets, or ground in mills erected for the purpose, was formerly a great article of fodder in the counties of Anglesea and Carnarvon. Farmers were then accustomed to sow furze for their horses; and sometimes to let the crop at a certain price per acre, which was frequently found to pay better than a crop of wheat; but Ceres at length seems to have grown ashamed of such husbandry; and the lands are in general converted to bear more useful crops.

Hogs. The original Welsh breed had small ears, which, probably, by a cross with the Berkshires, produced the slouch-eared hogs, which were lately general through the country. They are slow feeders, and the rearing of them is now upon the decline, and giving place to that of more improved breeds, especially Berkshires.

Bees. "The ancient Welsh held these industrious insects in great veneration, and believed them to be of Paradisaical origin." (*Wotton's Leges Wallicæ*, p. 234). For this reason their priests taught that the chanting of mass was not acceptable to the Deity, unless the lighted tapers were made of their wax. Out of their dulcid stores they brewed their national liquor, me-theelin, or the medicinal beverage.

When the country was almost a continual wilderness, almost every hollow was an apiary. Their nests on the wastes were the property of the lords of the soil, and rented by some of their vassals. On freehold lands they were claimed by the respective proprietors. The discoverer of a swarm was entitled by law to a reward of one penny, if they were domesticated bees; and one penny and a dinner, or in lieu of these the whole of the wax, if they were of the wild race. Whoever cut a tree upon another person's property, in order to get at the nest of bees, was to be amerced the full value of both tree and bees. The respective prices of different swarms were ascertained by law.

Early swarms were reckoned of full value by the first of August; such as swarmed after that day were not valued above four pence until the following May.

In comparison with the prices of other articles, at the time the Welsh laws were framed, bees seem to have been very dear, and consequently scarce; but their price set upon them by law was much above the real price in commerce, between buyer and seller. This was owing to the veneration they were held

7045. SOUTH WALES. Six counties, and some of mountainous surface; generally of a salubrious more temperate than the air of North Wales. The generally rich in the vales and declivities. Of minerals deal of lead.

### 1. Property and Buildings.

As in North Wales, in South Wales in general the custom of white washing cottages is prevalent. In Glamorganshire, not only the inside and outside of houses, but barns and stables also, walls of yards and gardens, the stone banks of quickest hedges, and even solitary stones of large dimensions, house blocks, &c. near the houses, are white washed. This practice is traced to a very remote antiquity. *Diodorus Siculus* is quoted as mentioning the British custom of white-washing houses. Gentlemen's seats are distinguished from cottages, not only by their size and plans, but also by their colors. In Glamorganshire, gentlemen mix ochre with lime, to make their seats of Isabella yellow. In the north of Pembrokeshire, &c. the taste is reversed; the cottages are of a very dingy color, and gentlemen's houses are white washed; the maxim is—not to be what the lower classes are, not to coincide with the vulgar in their practices.

### 2. Occupation.

Farms of all sizes; two mountain farms of 1400 acres each; general run from 30 to 100 acres, average of the district being fifty and sixty acres. In the uplands, rearing of stock is the main object, without neglecting the produce of the dairy; whilst they find convenience, though without profit, in a scanty and precarious tillage. In the lowlands, or moist loams, especially in the more humid climate of the western counties, grazing is considered, and generally recommended, as most profitable.

Upon an average of the whole, the district may be said to be occupied in that kind of system called mixed husbandry; breeding, dairying, and tillage; varying in the proportion of each, in different places according to the impiousness of existing circumstances, which will be hereafter more fully explained.

Farmers may be classed, as proprietors farming a part of their own estates, small proprietors or yeomen, farmers of the old school, and book farmers.

"Book farmers, the aristocrats of Marshal, are those who know agriculture only by reading about it. They is their *ne plus ultra*; as they generally grow tired before they are much acquainted with practice. The practice of the country they come to reside in is all wrong, and the inhabitants all savages. They bring ploughs and ploughmen generally from a distance; and when the masters return the ploughmen return, and the ploughs are laid aside. They hold the farmers of the old

in by the legislature; and intended to deter the subject from offending against the statutes made to preserve them. As a confirmation of this opinion, every thing that belonged to bees had its value exaggerated in law: even a bee-hive was appraised at two shillings, when a new plough without irons was valued only at two-pence; a cow forty-eight pence, a yearling calf fourteen pence, and a suckling calf one penny.

The sacred esteem in which bees were held at length declining, aparies were gradually reduced to their present fewness of number. However, several persons still execrate the profane act of disposing of their bees for money; but will, nevertheless, let them out for one half share of the honey and wax, when they are killed annually in autumn; and the whole live stock to be parted equally between them at the end of the fourth year."

In Wales, as in Poland, when spirits and beer became more common, the use of methuein declined, and bees were neglected. Hence, it may be inferred, that the veneration in which this insect was held in these and other countries, was owing to its affording almost the only, and, at all events, the cheapest and most powerful means of indulging in that which man, in all ages and countries has considered the *summum bonum* of enjoyment. — intoxication: an enjoyment which, when it is procured legitimately from that "transcendent liquor," wine; with the American Indians, from opium; or the Turks from opium, has this advantage over all others, that it is more immediate, more intense; that it is within the reach of every one; that every one can have it to the full; and that for the enjoying which no man is envied by his neighbor.

### 11. Political Economy.

Great improvements have been made in the roads and bridges of late years, especially by Lord Penrhyn, Wynn, Madocks, and Government, under the direction of Telford. Previous to the year 1785, the annual exports of slates from Lord Penrhyn's quarries at Dolawen, did not exceed 1000 tons: which, owing to the ruggedness of the road, were conveyed from the quarries to the port, a distance of six miles, in panniers on horses' backs. His Lordship formed a broad-wheeled cart and waggon; and from the quarries he extended the road nine miles further to Capel Carig, through Nantfyrnac, and the romantic interior of Snowdon, at his own expense, the whole tract being his property. The increase of the slate trade caused his Lordship afterwards to have an iron railway, the length of six miles, from Dolawen quarries to Port Penrhyn.

The chain bridge now erecting across the Menai by Telford will, when completed, be one of the most extraordinary works of the kind in existence.

Of canals there are several, with stupendous aqueducts and bridges. The aqueduct of the Emsmere canal, thrown over the Dee, is the first in Europe. It was opened in November 1805.

Manufactures chiefly blue cloth, blankets, flannels, and Welsh plains or cottons. The best Welsh flannels manufactured in Montgomeryshire. Welsh cottons made since the time of James the First, have the warp of fleece wool, and the woof a mixture of one-third or one-half of Welsh wool. Knitting stockings and caps very general among the females of cottages and small farms. Argillaceous schistus is converted into slates for the roofing of houses and other purposes, to a very great amount within this district.

Polished iron extracted from the iron-ore of Flintshire, for the use of cotton dyers. A variety of other manufactures to a moderate extent. Several agricultural societies.

islets, comprising together 2,470,400 acres of hilly climate; cold on the mountains; but on the whole the soil argillaceous red loam, or calcareous, but generally there is abundance of iron, coal, lime, and a good

school, as they called them, in sovereign contempt, who, in return, deride their perillities, and, in their own quaint phrase, style their ineffectual attempts to establish a system of improved agriculture, "a *flask in the pan*." They considerable good in the vicinity they dwell in, by employing laborers; and by their imported implements they open the eyes of mechanics. Most the harm they do, is to themselves. They injure others mostly by an exorbitant advance in the wages of servants, especially of such as pretend to be farm-bailiffs. They give double the wages that the old established farmers in the best cultivated counties, Salop or Hereford, &c., will give. They have generally very exalted notions of the value of land, and the powers of soil. They read of the high returns of crops in England or elsewhere, and calculate there upon the value of land in the uplands of Wales; which, if they have farms to let, makes it extremely difficult to deal with them. Their opinion of manure depends on the book they have read last. If Jethro Tull is their favorite author, soil requires nothing but ploughing and stirring. With *A. time is every thing*; with his brother B. only a few miles distant, and on the same kind of soil, *lime is nothing*.

### 3. Implements.

The Welsh plough is in common use; and perhaps a more awkward, unmeaning tool, is not to be found in any civilized country. It is not calculated to cut a furrow, but to tear it open by main force. The share is like a large wedge; the coulter comes before the point of the share sometimes; and sometimes stands above it: the earth-board is a thing never thought of, but a stick (a hedge-stake or any thing) is fastened from the right side of the heel of the share, and extends to the hind part of the plough: this is intended to turn the furrow, which it sometimes performs, sometimes not, so that a field ploughed with this machine, looks as if a drove of swine had been moulting it.

The Rotheram and other improved ploughs are in use among the proprietor and book farmers, and the Scotch plough is coming into very general use. A gentleman, a naval officer, in Cardiganshire, introduced the light Rotheram, and insisted on the ploughmen using them. As soon as he turned his back, the new ploughs were dismissed, and the old ones were brought into the field; and one day, he was committed the road to the flames, and set the new ploughs a-going. Afterwards taking a ride to cool himself, and returning, he found the new

ploughs in the ditch, and old ploughs borrowed from the neighbors at work: the master then thinking it useless to persevere, gave up the contest. "I have," said he, "seen various kinds of human beings, in different parts of the globe, from latitude ten to latitude fifty-four, but none so obstinately bent on old practices as the Welsh."

H. Lewis, Esq., of Gallt y Gog near Caermerthion, being equally unsuccessful in effecting a revolution at once, tried the plan of altering the old ploughs in a slight degree, and hopes, by one alteration after another, at length to transform them into Rotherham ploughs "unaware that his sturdy ploughmen of *Wagons* and *clumey* two and three horse carts are in general use; almost every farmer of forty pounds a year rents has a wagon. Single horse carts gain ground but slowly. They were introduced into the vale of Towy, several years ago, by Lord Robert Seymour; into Cardiganshire, by Thomas Johns, Esq.; and into Brecknockshire, by Sir Edward Hamilton.

A *hay rake*, with the head forming unequal angles with the handles, is in use in Glamorganshire, the only advantage of which is said to be that of not obliging the rake to step his foot backward at every reach.

#### 4. Arable Land.

In general wretchedly managed, especially the fallows. The reporter proposes to send farmers' sons to improved districts to serve apprenticeships, as better than examples set by strangers, which have been tried without success. A patriotic land proprietor brought what were considered as enlightened farmers from Scotland into South Wales; but as a casual very judiciously observes: "New practices in husbandry will be most likely to succeed through the medium of the natives of the country. They have an unconquerable dislike to every thing introduced by strangers; and not without some reason, as most of the people who have come into this country from the English counties, and commenced farmers, were in bad circumstances at the outset, and therefore have not succeeded in their undertakings; and the natives, eager to reprobate any thing new, readily attributed their failure to defective practice, rather than to the real cause, want of capital. This observation will be found to be generally true in every country. Few persons in good circumstances can be tempted to migrate; whilst others of a different description are frequently under the necessity of doing it; and, generally, it can only tend to hasten their total failure. Then the teaching of the natives, as recommended above, would have a much superior effect in establishing the doctrines of the new schools, than the introduction of any strangers into the country.

The sand banks checking the progress of the tides into a flat tract in Glamorganshire, in order to render them more firm, they are matted with the roots of the sea mat-weed (*Arenaria arenaria*). The hon. T. Mansell Talbot, binds each of his tenants, who rents land in the adjoining marshes, to give yearly the labor of a day or more, in proportion to his holding, as a kind of statute duty, for the planting of this reed; and experience has proved its good effects.

#### 5. Grass.

By a correct map of the rivers of a district, with a scale of their fall in a given number of furlongs or miles, and of the mountains from which they flow, and those distinguished by kinds of "quality colors," a geologist might give a fair estimate of the quality of the soils and grasses of the respective valleys intersecting that district, though anomalies frequently form exceptions in valleys as well as on sideland places.

The practice of fogging pastures, almost peculiar to Cardiganshire, has been already described (5255). The reporter saw a piece that had been fogged successively for sixteen years; and according to the tenant's information, was improving annually. When land has been mowed too long, one year's fogging is supposed to recover it. Mossy pastures are benefited by it. It replenishes the soil with seeds, that by this means are suffered to ripen and shed on the ground; and it is said that two years fogging will recover lands, let them be ever so run out by tillage or mowing. Cattle used to fog, will quit hay that may be given them, and clear away the snow with their feet to get at the fog. The fields proper to be kept in fog, must be of a dry, sandy, and close soil; the argillaceous rather than the siliceous earths should prevail in it; but not so much as to be over retentive of water.

The late Thomas Johns, Esq., of Havod, observes, "Fogging is getting out of repute: it must have originated in chance, and want of a summer stock of cattle."

Clover is grown in some few places for seed, which is separated from the heads in a common corn mill, the upper millstone being replaced for a time with a square piece of oak furnished with eight wings studded with nails on their upper surfaces. These spokes, by their rapid motion, soon beat out the seed.

#### 6. Gardens.

On the maritime coast of South Wales generally very productive; those of the cottagers better attended to than in other parts of the district; a pleasing mixture of flowers, small fruits, and vegetables.

*Orchards* in Radnorshire and Brecknockshire thrive well in the valleys, but more especially in the vales of Wye and Usk. Not much cider made, excepting on the Wye.

#### 7. Woods and Plantations.

"It appears from old deeds, that estates were formerly sold at an inferior price, in consequence of their being crowded with timber. Times are now changed."

There are a great many oak woods and coppices in hill

parts of the district, and many thriving plantations in every part of it. It is calculated that at an average six millions of trees are annually planted; if this be the fact, it is probable nine tenths of them either die or are doomed to come to nothing, for at this rate, in fifty years, there would be 150 trees for every acre in South Wales, which, added to the old wood and copse, would give 300 trees, or enough to render the country one entire forest.

#### 8. Improvements.

Numerous inclosures have been made, and fencing, draining, and, in some cases, watering practised, as in other countries. There are nearly 15,000 acres of fen and sands on the coast of Cardiganshire, which are considered highly improvable, and which it has been at different times in contemplation to embank. One of the worst parts of this land, the late agriculturist Dr. Anderson, who was much with Johns of Havod, said he could make it carry wheat in five years.

#### 9. Live Stock.

From ancient records it appears that the colors of Welsh cattle were white, with red ears, like the wild breed at Chillingham (1550); they appear to have been in a wild state so late as the time of king John. The present stock are of four kinds: the coal-blacks of Pembroke; the brownish blacks, or dark browns, of Glamorgan; the black runts of Cardiganshire, Caermerthenshire, and the western parts of the counties of Brecon and Radnor; introduced breeds, from Herefordshire and Shropshire, into the eastern and more fertile parts of Brecon and Radnor.

Cows are kept for breeding, and making butter and skim-milk cheese. Johns has proved, that at Havod, cheese may be made at will, so nearly resembling Parmesan, Stilton, Gloucester, or Cheshire, that the difference cannot be perceived by good judges; and that the whole mystery consists in various modes of producing it from the milk.

The *sheep* of South Wales are of four kinds: mountaineers, Glamorgan, vale sheep, Glamorgan Down sheep, and crossed and intermixed breeds.

*Mountaineers* occupy the hills in the several counties of the district.

The Glamorgan vale sheep, is the only breed in Wales, not introduced within memory of man, that produces combed wool.

The Glamorgan Down sheep is a beautiful and excellent small breed. Feeding upon the oldest and sweetest pastures of the limestone tract, their mutton is superior in quality to most, and inferior to none; their wool is of the short clothing kind, and fine. They are generally polled.

With crossed and intermixed breeds many experiments have been tried within the district, and most of them confessedly without the expected success. Particular breeds of sheep have their peculiar diseases, which continue in their constitution, wherever they are removed. The limestone tract may be considered as the healthiest for sheep within the district, but even there the imported modern breeds have brought with them the scab, the foot-root, the goggies, maggots, and a long train of diseases never heard of before in Wales: these are to be ranked among the profits of commerce.

*Horses.* The small Welsh merlins or palfreys are now in many parts nearly extinct: they are a pigmy race, and may now and then be found in the hilly valleys of the interior of the district. There were formerly a very good breed of hardy strong punches, fit for riding and walking upon the farm, being a cross between a good-sized horse and the small merlins; and very useful they were; but the breed has almost been totally neglected and lost: for they cross now too much with the large and sluggish cart horses.

#### 10. Political Economy.

Roads as in North Wales, or worse. Road ploughs in use; a characteristic both of their state and of the nature of the materials. Good limestone however in the coal districts, and especially in Glamorganshire. Manufactures of woollen in many places; and, owing to the abundance of oak coppen, many hides tanned. Potteries on a large scale at Swansea, Cardiff, and other places. Extensive iron and coal works, lime works, and slate quarries in Cardiganshire, &c.

The *Lias limestone*, (lime and iron combined, the stone of a bluish or greyish color), though found in many parts of England, is no where so valuable as that at Aberthaw. When burnt into lime, it is of a buff color, the characteristic, according to the engineer, Smeaton, of all limes setting in water. Lias limestone in all parts has a peculiarity of stratification and exterior character, so that a rock of it may be known at a distance. The strata are of various thickness, from a few inches to a few feet; and those commonly separated by a few inches thickness of marley clay. The ferruginous ingredient seems to be concentrated in the interior part of each stratum; the outer sides thereof being more porous, and of a paler color. In inland places the strata are burnt altogether, the argillaceous as well as the ferruginous calcite. Here, at Aberthaw, or on the maritime coasts, the strata tumbled down, within reach of the tides, are broken and rolled about, until they are reduced to rounded pebbles or nodules, from a few ounces to many pounds weight; and these consist only of the nucleus or kernel part, the more useless shell being worn off by the abrasion of the furious tides. These rounded lias pebbles are driven on shore in inexhaustible quantities.

Of *agricultural societies* there are several: that of Brecon, instituted in 1755, the earliest in Britain after that of Edinburgh.

### SECT. III. Agricultural Survey of Scotland.

7046. The surface of this country is estimated at 18,944,000 acres, in three natural divisions. The first lies north of the chain of Highland lakes, which stretches from Murray to Mull, and consists of little else than dreary mountains and some moors; the second, or middle division, extends from this chain of lakes to the rivers Forth and Clyde; it is mountainous, but cultivated in the valleys, and on the eastern shore to a considerable extent; the remaining division is covered by hills with some mountains, but every where

cultivated or improvable, and highly favorable for most branches of agriculture. Though Scotland, as elsewhere observed (771.), was far behind England in cultivation, till the middle of the last century; it has now greatly outstripped that country, especially in arable husbandry: a proof that this is the general opinion of enlightened men may be deduced from the notices just given of the English and Welsh counties, in which it appears that the improvements introduced or attempted to be introduced on arable land, are with few exceptions the implements and practices of Scotland. In the management of meadows or old pasture, Scotland cannot be conspicuous; as the climate is not naturally calculated for that kind of husbandry. The winters are too long and severe, and the surface too irregular. In regard to live stock, the palm of improvement is undoubtedly borne away by England; but though there is not that enthusiasm in Scotland, nor such large prices given for capital specimens, it may be safely asserted that breeding and feeding are conducted as systematically and successfully there as in England. We shall glance at the different counties in the order of their proximity, beginning with that containing the capital. It may be sufficient to mention here that leases are universal in Scotland, most generally for nineteen years, often for twenty-one, sometimes for fourteen, but seldom for a shorter period. The poor are supported by voluntary contributions at the church doors, though an assessment on property, half paid by the proprietors, and half by the tenants, may be made if necessary, which is very seldom the case. Tithes were commuted for their value in land, and land's produce at an early period. Every parish has a schoolmaster, who is paid jointly by the proprietors and the farmers. There is a professorship of agriculture in the Edinburgh University, ably filled by Dr. Coventry, a man of whom it may be truly said, that he is universally esteemed and beloved.

7047. MIDLOTHIAN. 230,400 acres, one third hilly and inaccessible to the plough, and two thirds in tillage, pasture, or wood. The store sheep farming is practised on the hills, and a mixed agriculture on the low grounds. Green crops and potatoes are extensively cultivated for the Edinburgh market, and most farmers are more indebted to the manure they receive in return, than to the soil, or superior skill; many of them are townsmen, amateurs, and speculative cultivators. The Dalkeith Farmers' Society, one of the most useful that has been formed, and which still exists, belongs to this county; and in it also was founded the British Wool Society, now extinct. (*Robertson's Survey*, 1795.)

1. *Geographical State and Circumstances.*

*Climate* free from extreme heats or colds; snow seldom falls on the low parts of the county before December, lies from three to ten weeks. In eight years, the greatest quantity of rain that fell in any year was 56.8. inches, and the least quantity 9.6 inches.

*Soil* much diversified; lands hanging to the north always the most fertile.

*Minerals.* A bed of coal extends across the county from S.W. to N.E. from seven to eight miles in breadth; worked for two centuries. Limestone, freestone, granite, and whinstone very abundant. Millstones in the parish of Pennycook, also marble. Some copper and iron ore, marl and jasper pebbles on Arthur-seat.

*Water.* Streams inconsiderable. Esk (*Usk*, Gael.) the largest river; few fish from the rivers or streams, but abundance from the firth or sea.

2. *Property.*

About 540 estates in the county, divided by the reporter into seven classes; first class from two to 3000*l.* or upwards; fifth class 100*l.* and upwards; sixth class, least properties; seventh class, properties of corporate bodies. Total rental in 1795, 191,000*l.*; Duke of Buccleugh the first proprietor.

3. *Buildings.*

Many gentlemen's seats, and some fine ruins of castles and religious houses.

*A farmer's mains*, as it is here called, consisted formerly of a set of low buildings, in the form of a square, one side was occupied by the master himself, whose habitation was composed of two or three dismal apartments, on an earthen floor, having a low ceiling and a few diminutive lights. On another side stood the barn, in which the roof timbers, from the idea of giving more strength, were built into the wall from the foundation; the wall itself not being more than five feet in height. Opposite to the barn were the stables and the byre, or cow-house. The stables were totally without division, and the horses fed in common; but the neat-cattle less passive, were each confined to their stables. The cottages occupied the remaining side: in the midst of all lay the dunghill. These buildings were made of turf and stone alternately, or with stone, and clay for mortar: the roof of thatch, or of thatch and *divot* (turf or sods) intermixed.

Farmers now in the first style of commodiousness. An example given of Gogarbank farm.

*Cottages* formerly very mean, now much improved. Farms vary from 100 to 300 acres. Farmers divided into three classes; speculators, converts from other professions; industrious laborers who have acquired some property; and farmers sprung from farmers.

*Speculators.* "In the immediate vicinity of the town, the greater part of the lands are cultivated, not by actual farmers, but what may be more properly termed speculators in agriculture, people with whom farming is but a secondary object; their chief employment being still what was their original profession, as bakers, brewers, innkeepers, or some other distinct occupation; and who are often to be found in their town lodgings, or in their counting houses, than in the midst of their farms, attending to the operations of husbandry. One certain effect, which the speculations of this class produce, is,

that the rent of land is raised above its natural level; for, as they have always some other business to live by, they are enabled to afford more rent; and in fact give more than an actual farmer, whose sole dependance is upon husbandry, is able to pay; while their exertions in agriculture, though in general founded on good principles, commonly end in disappointment to themselves, for want of that unceasing attention which is indispensable to good cultivation, but which their other avocations prevent them from bestowing."

*The moor-land farmers*, as if in conformity to the soil, which has undergone very little melioration, and to the climate, which is naturally severe, seem still to retain a strong cast of the manners of their forefathers, and to live and toil under the same uncomfutable circumstances. Their houses are damp, smoky, and diminutive; their fare simple and limited, and their labors hard and even oppressive. But they have days of relaxation, in which they enjoy themselves at fairs and markets; their marriage festivities are almost boundless, and their funerals are pompous and ostentatious. Religion is maintained in all the austerity of Oliver Cromwell and the covenant.

These farmers are the only ones in a county containing a capital town, who are likely to better their condition. Being inured to the practice of the most rigid economy, they will, when translated to a warmer climate and more genial soil, very forcibly feel a melioration in their circumstances; and if they have fortitude enough (as the first race of them generally will) to persevere in their original habits of frugality, they may, by dint of mere saving, at the rate, perhaps, of two and a half per cent. yearly on their capital, accumulate, in a life-time, a sum that may be esteemed considerable. But this thriving state will only last during the first generation. Their sons, habituated in time to an easier mode of life, will, amid the great luxury with which they are surrounded, lose their primitive simplicity of manners, and with it the faculty of saving, on which alone their prosperity depends.

4. *Implement.*

Old Scotch plough, long and heavy, and drawn by four or six horses or oxen, and till about 1768, when Dr. Griev and Carlisle, clergymen, tried wheel ploughs of a lighter construction, which they had seen in use in Dalkeith Park. Soon afterwards Small's improved plough came into notice.

5. *Enclosing.*

No commons or common-fields. Hedges first planted about 1760.

6. *Arable Land.*

When ridges are raised high, they should not be laid south and north, as the crop on the east side of such ridge is commonly found very defective. The same thing holds in the county of Lancaster.

7. *Grass.*

Very little permanent grass exclusive of the hills and moor lands. Alluvial lands on the banks of streams so liable to immense floods, bringing down soil, &c. that if in grass it would often be much injured; considered therefore more profitable to keep them in corn.

8. *Gardens and Orchards.*

Henry Prentice, who died about 1786, was the first who cultivated white peas, potatoes, turnips, and sundry other culin-

ary plants, on an extensive scale, for the Edinburgh market, about the year 1746. Before that period, the supply was limited to what could be carried in baskets; his cart being the first that appeared with kitchen stuff on the streets. He even raised cucumbers in the fields; but his cart load of these met with so little sale, as not to encourage a repetition. Though he died a pensioner on the poor's funds of the Canongate, his name deserves to be noticed with respect, not only as having introduced several of our best vegetables into cultivation, but from his practice as a cultivator, which was spirited and judicious, however little it turned out to his own account.

**Strawberries.** About 200 acres on the banks of the Esk, and chiefly near Rodin. Crop continued on the same ground without ending; but digging down and replanting every fourth year. To change every twenty or thirty years esteemed a better practice. Lands in nursery 200 acres. Mawer's hothouses at Dalry, and hotwells of his invention, figured and described. The hothouses heated by steam. Mawer was a Lancashire man, and formerly gardener and steward to the Earl of Aberdeen. He was an excellent gardener and farmer; a man of very general information and highly respected. He was extensively employed as a layer out of gardens and roads, and had the general charge of the gardening and tree department on some gentlemen's estates. The compiler of this Encyclopedia was his pupil, amanuensis, and draughtsman for the three years preceding his death, which happened suddenly from apoplexy in 1800.

#### 9. Woods and Plantations.

About 5000 acres occupied, the greatest part artificial, and planted since 1750. Hedge-row trees never come to any great want of shelter: belts do no good unless twenty rows thick at least.

#### 10. Wastes.

None; but extensive tracts very poor.

#### 11. Improvements.

Draining well understood and extensively practised. Johnston, who wrote an account of Elkington's mode of draining, a native of the county. Edinburgh and Leith afford about 40,000 cubic yards of street dung annually, which is commonly laid on the lands within five miles of town. Horse dung, however, carried twenty miles or further.

More need for weeding on the arable lands of this county than in those of any other in Scotland; supposed from more town manure being used. The town manure contains the seeds brought in from the country in hay and straw, which are of various kinds; but chiefly wild mustard, wild radish, dock, thistle, poppy, couch grass, &c.

#### 12. Live Stock.

Little attention paid to this department. Galloway and Ayrshire cows preferred, and Clydesdale horses. Some buffaloes of the Mysore variety introduced by Col. Murray; not supposed to turn to any advantage, either as milkers, or for work, or the butcher, but form a variety in parks. Lord Morton subsequently introduced the quagga (*Equus quagga*) on his park at Morton Hall for the same purpose. Bees a very popular species of live stock with all classes.

#### 13. Rural Economy.

Well supplied with work people from the highlands and Ireland. With the exception of some farm servants in the immediate vicinity of Edinburgh, they are, in general, orderly and moral. Children taught in the parish schools; reading at one shilling and four-pence, writing and arithmetic at two shillings and sixpence per quarter; Latin, &c. in proportion. The cottages of ploughmen consist generally of two rooms on the ground floor, with a pigstye, and 100 square yards, or upwards, of garden ground. The furniture consists of two beds, a few chairs or stools, a table, chest of drawers, clothes press, &c. and they are all ambitious of having a time-piece, if it were only a cuckoo clock. The whole may be worth from ten to twelve pounds. The Sunday's dress of a young ploughman consists generally of a coat of blue cloth, at five shillings and sixpence the yard; velvet vest, corduroy breeches, white cotton stockings, calf-skin shoes with black silk shoe-knots, shirt with ruffles at the breast, white muslin fringed cravat, and a hat worth eight or ten shillings. The shoe-knots and ruffles are, indeed, rather uncommon, but all the other articles are very much in use. They make a very good appearance, and even pay attention to the fashion. In their food they still live in much the same simple way as their forefathers. Oat-meal forms the basis, or principal part of their sustenance. They have it regularly to breakfast and to supper, made into potage, which they eat with a small allowance of butter-milk. At dinner they eat it in bread, in addition to their kate, a kind of

7048. EAST LOTHIAN. 190,363 acres of surface, under an exceedingly variable climate, the greater part of excellent soil, and well adapted for cultivation, but the southern district, Lammermuir, hilly and mountainous, with a moory soil, severe climate, and chiefly under native grass and herbage. Some of the most distinguished Scotch agricultural patriots, authors, and mechanics belong to this county, as Cockburn of Ormiston, Thomas sixth Earl of Haddington, Fletcher of Salton, Adam Dickson, Robert Brown of Markle, the projector, and for a long time editor, of the Farmers' Magazine, Somerville, author of the agricultural Report, Meikle, inventor of the threshing machine, and various others. (*Somerville's General View*, 1805.

#### 1. Property.

Generally in considerable estates; the largest about 15,000, and not many under 1000 a year. Tenué generally of the crown, (i. e. freehold), some hold of subjects superior (copyhold), and some of the corporate towns of Haddington and Dunbar.

#### 2. Buildings and Implements.

It may be sufficient to state that they are such as we have described in the body of this work as of the best description. Farms generally large; medium of the county about 4000 a year; highest 15000 to 18000. The first enclosures were made about 1720; farmers were introduced from Holland in 1710; the two-horse plough used in 1772; and the first threshing machine in 1786. Fallowing was introduced from Eborac about the same time as hedges. The sixth Earl of Haddington was the first proprietor, and John Walker, of Beanson, near Dunbar, the first farmer. He took the hint from some English travellers, while they spent a night at his house, and with whom he had a good deal of conversation upon the subject, so much to his satisfaction, that he made an experiment upon six acres the

soup made of barley broth, intermixed with greens and pot-herbs. To this they add at times potatoes, and fish of different kinds: seldom wheat bread, and still more rarely butchers' meat. This mode of living, in which, although with no great variety, there is always abundance of food, seems to be very conformable to the natural constitution of the people, as they are found to go through their labor without feeling themselves oppressed and enervated, and the state of health which is very seldom interrupted. At an average, they are not above two days sick in a year.

What is above stated refers chiefly to the condition of farm servants, who are hired by the year, and whose principal employment is about the horses, in the fields, or on the road. There is, however, another class of work people attached to a farm, who are hired by the day, or by the week, and whose employment is usually in jobbing about the farms, the fences, or the water furrows. These are called laborers, and in their circumstances and mode of living there is a considerable difference between them and the others.

Although their wages are in general at a higher rate than the hired servants, yet they make not such a good appearance in their dress, nor are so well seen to in their victuals, as these. They are generally, as we may see, from *hand to mouth*, always in want; which seems to arise principally from getting their whole wages in money, from week to week, which leads them continually to market, providing their daily sustenance; a province left generally to the charge of their wives, who, from this constant running about, get into habits of idleness and want of attention to that good housewifery which is the glory of a decent cottager's wife.

The quantity of coal used by the common laborers is about three fourths of a ton for each soul in the family yearly, by farmers about two tons, and in families of the highest rank about six tons. The price at the pit is from five shillings to seven and sixpence the ton, according to its vicinity to Edinburgh.

Such was the state of things in 1795. Now (1825), as the distance of thirty years they are, doubtless, materially altered. The use of wheaten bread is principally from getting their meat much more common, and cottages more commodious.

#### 14. Political Economy.

Roads so bad previously to 1714, that wheel carriages for the purposes of agriculture were very little used: even till 1760 hay and straw carried to Edinburgh on horseback, and the dung taken back the same way in bags. Sledges a good deal employed in those times: they are mentioned in the turnpike act of 1751, but unnoticed in that of 1755, which shows they had been disused; a proof of the extraordinary progress of improvement when once commenced, in consequence of a demand or desire for it, which goes on very differently. The roads of this county now under one of the M'Adam family. Some recent canals and rail-roads. Glass, ropes, and soap the chief manufactures. Iron works at Craigmyle, where nails, spades, files, &c. are extensively fabricated. Several paper mills, flour mills, and various minor manufactures and works for local consumption.

#### 15. Obstacles to Improvement.

Illiberality of landlords, game, thirlage, the dogs of Edinburgh, who greatly harass the sheep, the chief obstacles.

#### 16. Miscellaneous Observations.

The Farmers' Society of Dalkeith, for the prosecution of thieves and encouragement of agriculture, instituted in 1760, still exists, and has done much good. It is composed almost entirely of practical farmers. Small's plough, the winnowing and thrashing machines early noticed and recommended by this society. The farmers in this county a long time had in contemplation to get instituted by legal authority, a society for the creation and management of a pensionary fund for the widows and orphans of farmers, on principles similar to those which govern the widows' fund of the ministers of the Church of Scotland.

An appendix to the report contains thirteen papers, some of which are curious in an historical point of view; and as showing how soon, in a rapidly improving age, a man's best ideas and remarks are distanced by those of a few years afterwards. One of these papers describes the origin and progress of the British Wool Society, which was begun in this county by Sir John Sinclair, in 1791. The economy of Johnston's dairy is deserving of notice for accuracy in the details, and for new practices, such as making butter from whey, feeding cows on whins, &c. Macknight, another amateur, and Hepburn, an ingenious landlord and cultivator, are also worth reading.

following summer, which he carried through in spite of the animadversions of his neighbors, who were divided in their opinions as to the sanity of his mind, or the stability of his circumstances. The result of the experiment gave them a better opinion of both, and the return, so very abundant as to induce him to extend his next year's fallow break to twenty acres, soon after which the practice began to spread, and so early as the year 1724, following upon all the deep strong soils was common throughout the county, and has continued to be so ever since. There can be no doubt that the early excellence of the East Lothian agriculture was in a great measure owing to the introduction of fallowing, which, together with the use of drill crops, have continued to place it at the head of the Scotch counties. Potatoes introduced to field culture about 1760; turnips first by Cockburn, of Ormiston, about 1720; re-introduced and cultivated in the drill manner in 1760. Flax sown from time immemorial, but chiefly on a small scale, and for the home consumption of the country inhabitants. Every cottager has a small quantity, from half a peck to a peck sown, the produce of which furnishes linen for the use of his family.

*Lucern* tried with the greatest care, but owing to the climate, it was found to produce less bulk of herbage than red clover.

#### 3. Grass.

Natural meadows and pastures are not admitted into the East Lothian system of husbandry, as they are found only where nature or certain local circumstances render them, in some measure, unavoidable, and are never kept voluntarily, or from an idea of profit. Many farmers fallow land to lie for a few years in grass, especially where it has been exhausted by long and imperfect tillage; but fields of this description are not to be ranked as permanent pastures, for the object is to restore them as soon as possible to a state capable of bearing corn-crops to advantage.

*Clovers* introduced by the sixth Earl of Haddington and Cockburn, about 1720 or 1722, but made little progress till 1740; now generally sown with rye grass. Application, grazing, soiling, and hay, but chiefly soiling.

#### 4. Gardens and Orchards.

Some few market gardens and nurseries, but the climate does not admit of orchards, which are very rare. Every cottage has a garden annexed, sufficient to produce the various common kitchen vegetables for the cottager's family. This class of people are remarkably attentive to the cultivation of their little spots, and derive great advantage from them, at small cost; the labor is entirely performed after their ordinary work is finished.

#### 5. Woods and Plantations.

Scarcely any of the former, and none of the latter of any extent, excepting in gentlemen's parks. 800 acres on Tynningham, demesne, planted by the sixth Earl of Haddington, who wrote a treatise on planting, about 1715. Osiers cultivated by Sheriff, of Captain Head, for which, in 1803, he received the gold medal of the Society of Arts.

#### 6. Wastes and Commons.

Are in this as in other Scotch counties, generally enclosed, which is here an easy matter in comparison to what it is in England, in consequence of a general Act of Enclosure by the Scottish Parliament in 1695.

#### 7. Improvements.

Paring and burning little known, and not wanted, because very little ground is kept long in pasture that can be profitably employed in tillage, and new grass lands do not require these operations.

One attempt at irrigation on a sandy waste near Dunbar, the levels of which were taken by, and the water turned on under the direction of the compiler of this work, in 1805.

#### 8. Live Stock.

The practice of East Lothian, in this department, does not present much that can be generally interesting. Grazing, in nine cases out of ten, is carried on only as subservient to tillage, and therefore held a secondary object by cultivators. Many cattle are fed, but very few reared, in the county. Almost every person who practises the sheep husbandry, in the lower districts, buys and sells within the year. Some recent attempts have been made to keep flocks of full bred sheep, and, there is reason to believe, with considerable success; but taking the county generally, such attempts are of little importance.

*Cattle.* Every farmer keeps a small number of milch cows, but few keep more than are sufficient to furnish a regular supply through the whole year, of milk, butter, and cheese, for their own families. The same attention accordingly is not paid to the kinds of cattle, as in other districts, where they form a more important object of farm management.

It is very considerable numbers of oxen, which are purchased annually at fairs and markets, to be wintered in the fold-yard, or fed on turnips in the house. Cattle kept for the dairy, or fed for the butcher-market, are employed all that are to be found in the county, none are comprehended in labor. Every part of farm-labor, in which beasts are employed, is executed by horses.

*Sheep.* Permanent flocks, and regular sheep management may be said to be almost confined to the higher parts of the county. In the low country they are kept chiefly to eat the turnips, and sometimes sown grass, which is permitted to lie a year or two for pasture. Flying flocks are therefore generally kept; and as soon as they are fattened for the market, which is usually within the year, they are sold off. A considerable number of lambs likewise are reared, only so far, however, as to render them fit for the butcher.

As the great object in the lower districts is feeding, little attention is paid to particular kinds; every farmer keeps those which he thinks are likely to pay best for the food which they consume. The black-faced, or Tweed-dale breed, are most generally preferred for feeding on turnips, because they are most esteemed in the market; but many of the Cheviot breed are likewise kept, and even some of the improved Leicester. Of every kind of sheep bred, and most generally kept, in Lammermuir, is the black-faced, or more properly what is called the brocked-faced, a sort of dirty looking mixture of black and white; they are for the most part horned: when they are fed, the widders weigh from ten to twelve pounds per quarter, and the ewes from eight to ten on an average.

The Bakewell breed has been tried, but not extensively; indeed it does not seem well suited either for the nature of the climate or the quality of the food.

The Cheviot sheep were introduced several years ago, and are kept with advantage in many places. It is not the general opinion, however, that they can ever universally supplant the native breed, or even become equally numerous, with profit.

Of horses very few are bred in the county, not one perhaps in a dozen that are kept. In a district so well calculated for raising corn, it is more profitable to purchase horses, ready for work, than to be at the trouble and expense of rearing them. The farmers here are supplied with this part of stock, chiefly from the dealers of Ayrshire and Lanarkshire, who collect many of them in these counties, and procure not a few from Ireland. The horses generally kept are of that moderate size, which may be considered as equal perhaps to any others for combining strength with activity. They may be stated generally, to be about fifteen or sixteen hands high, and strong built. Many teams are well-matched, very handsome, capable of great exertion, and kept in excellent condition.

One will hardly be at a loss to determine the character of a farmer, from the condition of his horses. Very fine high bred

horses, exhibiting an appearance of being prepared for the market, may rather suggest the idea of idleness than of labor; but, on the other hand, lean spare creatures, worn out by toil and hunger, are the certain indicatives of a bad farmer, of one who is not thriving, and does not deserve to thrive. The man who uses bad instruments, cannot have his work well done; and one important and primary step towards good farming, is to keep the laboring stock in good condition. Horses regularly fed and regularly wrought, will perform a great deal of labor without failing off either in strength or appearance; it is of great importance, therefore, to direct the labor as equally as possible, through the various seasons of the year; and if, as must sometimes be the case, an extraordinary exertion ought to be made, they are in a proper condition for making it. When horses do fall off, it requires much more to restore them, than might have kept them in a good state.

*Hogs* are kept in considerable numbers in this county, at distilleries, starch works, mills, and breweries. Every farmer keeps a few, chiefly for supplying his own table, and the generality are able to sell some annually. Farm servants too, who have houses, are generally allowed to keep a pig for each family, which adds greatly to their comfort.

*Poultry, pigeons, and bees* kept to a moderate extent for home use. Much land on the coast, which would be thought by many unfit for any thing but rabbit warrens, now bears turpins and rye.

#### 9. Rural Economy.

These are not, perhaps, in the island more active or correct laborers, than the farm servants here, and certainly none more sober and respectable; and this may be in great measure, be ascribed to the terms on which they serve. Those servants who lodge in the houses of their masters, are, generally speaking, on the same footing here as in other places; there is nothing, with respect to them, which merits particular notice. A small proportion of farm servants, however, belong to this class; married servants are uniformly preferred; and those who reside in their master's house are, in many cases, not employed in regular labor, but perform that sort of extra work, and kind of household drudgery, which requires some hands on every considerable farm.

The far greater part of the regular labor is performed by married servants, called hinds; a class more numerous here than in other districts. These dwell in houses provided by their masters, where they receive their wages, in which they are generally placed, so to secure a full supply of such servants at all times. They are more steady generally than young men; their families, and the property which they have acquired, give them a sort of interest in their situations, and afford some security for their continuing longer in their places.

The hind occupies a house provided by his master, for which his wife works in harvest; he has a cow kept all the year round, generally ten bulls of oats, three bulls of barley, two bulls of pease, all of the best quality upon the soil, seed corn excepted. He has likewise a peck of flax seed sown, and about the sixteenth part of an acre of ground, well prepared, and sufficiently dunged for planting potatoes; his fuel is carried; he has his victuals during harvest, which is always four weeks, some of which he carries corn to market, he has an allowance, provisionally called mags, in many cases, which is used in sowing and building the corn ricks have, besides the ordinary wages, a pair of shoes and half a boll of wheat. On all well managed farms, the labor is carried on regularly at set hours; and though it is not understood that servants, who work horses, are absolutely exempt from extra work, yet they are very seldom required to do any thing of this nature.

It is not difficult to see, that the value of hind's wages, in money, cannot be accurately stated; that much of it is paid in the form of market price of the articles in which he is paid. On an average of some years past, it could not be less than twenty-five pounds sterling per annum.

The circumstance, which deserves particular attention with regard to this class, and which renders their condition so much more comfortable than that of the laborers in many other places, is the regular payment of their wages, in the necessary articles of life. They are far more comfortable than those who receive the same rate of wages in money, any where; they are generally more faithful to their employers, and infinitely more attentive to the interest of their families. They have all the necessary articles of food continually at hand, and seldom need to purchase any thing considerable, except shoes. Their wives can make linen from their own flax, sufficient for their families, and often cloth, for other articles of dress. The quantity of corn which they can afford to sell, with the surplus produce of their cows and hens, brings them as much money as fully answers every demand, and enables them to give a better education to their children, than is sometimes obtained by persons, considerably above their condition, in some other parts of the island. There are few of this class in East Lothian, who cannot read, and many of them can do so; none of them fall to the share of that ignorance, which is the curse of the ignorant; they have their children instructed in the rudiments of education, including the rules of arithmetic. One sees, about every farm-house, a number of children, vigorous and healthy, decently clothed, and exhibiting every appearance of being well fed. Not an instance occurs of any of these people soliciting relief from the public, unless they are by some accident disabled from their labor, or overtaken by the infirmities of age. Indeed the times which are hardest for the lower classes, in general, are usually favorable for them, because of their own and other articles which they have to sell, bears a better price, while what they have to purchase is not so much affected.

The cottage system, which found many advocates some time ago, was inferior in every view of the matter to the manner in which laborers in agriculture are accommodated here. Many of those who labored to introduce the new cottage system, deserved all praise for the purity of their motives; every friend of humanity will honor them for the generous interest which they felt in behalf of the laboring poor; but if they had understood the condition of the hinds in this county, they would have found out a much better plan for accomplishing their object, than giving to every cottager land to produce his subsistence. A hind here receives as much corn as such a cottager might expect to raise, his labor is not interrupted by any extra work, he is not paid out by extra and excessive wages to his employer, nor himself worn out by extra and excessive labor; he has no care upon his mind, no rent to pay, no bad seasons to dread, for whatever may be his master's crop, he is sure of his full share. If the laborer profit by this system,

the employer and the public profit still more; the employer does not pay a man who wastes half his strength at other work, nor rely on a servant who may sometimes disappoint him, by attending to other concerns. The public must gain in the increased quantity of human food produced, for without doubt, an acre of land occupied by a cottager, will not yield as much at as little expense, as if it made part of a farm cultivated by a person with sufficient capital.

Were all the farm servants over the kingdom paid in kind, it may be safely affirmed, from the experience of the places where this practice prevails, that the advantage would be great to themselves and to the public. The master might probably, in some case, find it more convenient to give money, but he is far more than recompensed for any tritling disadvantage attending the other mode, by the valuable moral habits which it is calculated to preserve. Every master, who properly understands his interest, will admit, that he had better pay sober,

honest, and industrious servants, than have those of a different description almost for nothing. From their being accustomed to pass little money through their hands, many of the farmers' servants in this county acquire such habits of saving, that they lay up a few pounds for old age, or to meet any contingency which may require more than their ordinary income.

#### 10. Political Economy.

The first turnpike bill for Scotland was obtained for this county in 1750. The main roads are on the whole good; but the bye-roads still admit of much improvement. There are no canals or railways; the commerce is chiefly in grain from North Berwick and Dunbar. There are oyster and other fisheries on the coast; and starch works, distilleries, and breweries, but no manufactures deserving notice. No agricultural society in the county; but that of Edinburgh, the earliest in the United Kingdom, was founded chiefly by gentlemen of this county, and especially Cockburn of Ormiston.

7049. BERWICKSHIRE. 304,640 acres, chiefly of gently varied surface, but partly of hilly and mountainous pasture. The soil in the cultivable part of the county, is chiefly light gravelly loam; the mountainous part, which occupies fully one-third of it, is a continuation of the Lammermuir hills. Climate comparatively dry, but cold and late. There are no metals or coal in the county; very little lime, but some stone-quarries of the trap and other coarse stones. Every one knows that this county is one of the best cultivated, and most systematically managed of any in the island, and that its products are nearly equally stock and corn. It is the county of Lord Kaim, one of the greatest patriots and best agricultural authors, and the first to propose a board of agriculture. It is also that of Small, well known as the improver of the plough. (*Kerr's Berwickshire*, 1808.)

#### 1. Property.

No very large estates; largest from 8000l. to 10,000l. a year. Many of the owners reside on their estates; some farmers have of late years become respectable proprietors. Resident proprietors usually draw their own rents; and those who live at a distance, employ an agent, or, if only temporarily absent, have it sent in a bank bill. Proprietors and tenants live in harmony and mutual good will, the rents of the former progressively advancing with the improvements of the country, and the fortunes of the latter augmenting continually, by industrious and judicious attention to improved agricultural practices, and to the amelioration of live stock.

#### 2. Buildings.

Farm-houses formerly of rough stone, clay, and thatch, now greatly superior to the houses that were occupied by the middle gentry, forty or fifty years ago. An excellent plan of a farmery given; but the cottages of the hinds appear uncomfortably small, and are calculated for close paneled beds, which, wherever health and cleanliness are objects, ought to be discarded. These cottages contain only one apartment, and a sort of dark lumber place, formed by the position of the paneled beds. We much wonder that the reporter, who talks so much of the commodiousness of the houses of farmers, should not have displayed a little more feeling on the subject of the accommodations of cottagers. These remarks apply more particularly to three plans of cottages, given in the general plan of a farmery (*Pl. facing p. 97.*) A detached plan of a cottage (*fig. 811.*) is given, rather better arranged than these double ones, but still, in our opinion, highly objectionable. It has two windows, whereas the others have only one each. The larger window is in the kitchen (*a*), the smaller in the

811

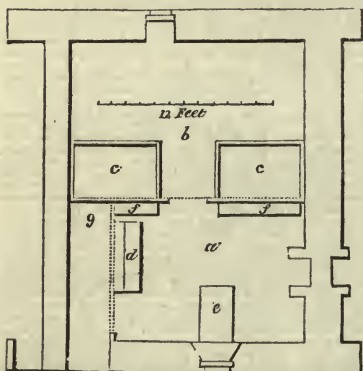

back place (*b*); these are separated by two beds (*c*); in the kitchen are shown a plate rack and dresser (*d*), table (*d*), and two chests (*f*). In the lobby a place for coals (*g*). No water closets in any of the plans.

#### 3. Occupation.

Farms generally large, and held on lease for different periods, from ten to thirty years, but commonly for nineteen years. Mode of culture aration and pasturage alternately. Under this system of alternation, judiciously conducted, it may confidently be asserted, that from 1000 acres will raise as much grain as one of equal size entirely under perpetual tillage, and will produce in addition as much beef, and mutton, and wool, as a separate farm of 200 or 500 acres under permanent grass. If this estimation be well founded, of which the reporter has no doubt, this alternate system is obviously of superior profit to the tenantry in the first place, to the landed interest secondarily, by increased rents, and to the public ultimately and always, in the proportion of at least twenty-five per cent, beyond what can be produced from the two branches separately pursued on the same extent of equal land.

In the hill district, the lands are mostly occupied as breeding sheep farms; taking advantage of all the favorable pieces of land, susceptible of cultivation, for raising a little grain to supply the farmer's family, servants, and horses; to afford litter and fodder from the straw during winter, by which dung is produced; to apply that dung to raise turnips, to carry on their sheep stagers, during winter; and, finally, to produce crops of artificial or sown grasses, for hay and early pastures, and to the great amelioration of permanent pastures.

In the neighborhood of towns and villages, various small possessions, from two or three acres or less, to twenty or more, are let on leases of various endurance, but mostly for short periods, to villagers who keep one or two horses, which they chiefly employ in leading materials for road makers, coals to the other villages, lime, or any other employment as may occur. The great mass of the land throughout the county is let in farms of every variety of size, from 40 to 50 acres, up to 1000 or more, to tenants on leases of fixed endurance, mostly for nineteen years.

The character of farmers in a large district of country must be various; but those of Berwickshire are very generally most respectable and intelligent, and their success has been deservedly proportional. They have almost universally risen completely above the operative class in knowledge, education, and manners, assimilating in every respect to the character of country gentlemen. In every corner of the county they are to be seen carrying on extensive and costly improvements, by draining, enclosing, liming, and marling; and by careful and judicious improvements of their live stock, sheep, cattle, and even horses, with all the energy and intelligence of commercial speculators. They trust to the certain profits of future years to reimburse their large expenditures with reasonable profit, which they are enabled to do through the sufficiency of their capitals, and the security of their leases. The former is derived from their own successful and intelligent industry, or that of their fathers, the latter from the good sense of the landlords, in seeing their own interests most materially interwoven in the security and success of their tenants.

#### 4. Implements.

No waggons or wheel ploughs, and though drilling turnips is universal, only one or two sorts of drills in use. Few implements, and those of a simple construction, suffice for the best practitioners in every art.

#### 5. Enclosing.

The cultivable lands are universally enclosed and subdivided into regular fields, generally by hedges; but sometimes by stone walls. In the mountain district, the farms are neither enclosed nor subdivided. The boundaries of each farm are indicated by landmarks, and round each farmery there are generally two or three small fields for convenience or cultivation. Trees very generally planted in hedgerows; hedges always cut with a bill in the wedge shape; never clipped and rounded, or broader at top than bottom; the sward means of hindering the production of side shoots, and in time producing naked places and gaps in that part of the hedge.

#### 6. Arable Land.

A ample details of the turnip culture in drills is given.

#### 7. Orchards, Woods.

None of the former in notice. Some native copes and woods, and artificial plantations, but not much woodiness, excepting round gentlemen's seats.

#### 8. Improvements.

In this county were begun about 1730, when Swinton of Swinton drained, marled, and completely enclosed his whole estate. Nearly about the same time, Hume of Eccles did the same. Both of these gentlemen were actuated by the example and acquaintance of Cockburn, of Ormiston; Henry Home, Lord Kaim, was one of the early improvers of this county, about 1746, at Kaim, now Beshborow. About 1750, the ardor of enclosing and improving the land, spread generally among the Berwickshire proprietors.

Paring and burning, irrigation and embanking not practised or required.

#### 9. Live Stock.

The cattle of Berwickshire are so much mixed by crossing, as scarcely to admit of any particular description. Upon the whole, they are short horned, thin hid, and kindly feeders, and have been much improved by crosses with bulls of the Teesdale breed, which is the kind chiefly admired in this district. Generally speaking the stags are not carried on to any age, and they are never worked. They are well fed from their youth up, and are generally fed off for market in their fourth year, very few reaching five years old. Cows, on the contrary, are generally old before they are fed off. Great

numbers of smaller cattle are bred upon the lower hills, and are disposed of to graziers in the low country for feeding, either on grass or turnips, or by a succession of both; and many Highland cattle of various descriptions, are bought in yearly for consuming straw, or for feeding on turnips during winter, and on grass in spring and summer.

The sheep bred in Berwickshire are of several kinds. In the most exposed of the Lammermuir and Lauderdale hills, the flocks are mostly of the black faced, or Tweeddale kind, and are there exclusively kept for breeding. In the cultivated tract, the new Leicester breed, in a great variety of degrees of perfection, now universally prevails; and it is believed that no other known breed, in the peculiar circumstances of this county, could be nearly so profitable to the farmer. They require, however, always to have abundance of food, and easily procured; for, being short legged, heavy bodied, and carrying a great weight of wool, they are unable to undergo much fatigue or hardship, and do not thrive unless plentifully supplied at all seasons. This supply, the agricultural system of the district amply affords, and is indeed admirably calculated for providing. On some of the best interior hills, and upon the higher exterior lands, verging on Lammermuir and Lauderdale, called the moor-edges, the Cheviot breed, or long sheep, are kept. An intermediate breed between the Cheviot and Le-

icester, usually called half bred sheep, is very prevalent upon the best of these situations. As a singular circumstance, the reporter records the case of a ewe of this county, which produced eleven lambs in three succeeding seasons.

Horses, as in East Lothian, brought from the west of Scotland.

#### 10. Rural Economy.

Farm servants managed as in East Lothian, and indeed, almost every where in the low country of Scotland.

#### 11. Political Economy.

Commerce chiefly grain, wool, and salmon; scarcely any manufactures, excepting the paper-mills. The salmon fisheries, including Berwick bounds and the English side of the river, employs about seventy small boats, and nearly 300 fishermen. All their fish are sold to a very respectable fraternity of traders in Berwick, named coopers, from their former business of making kils, and boiling the fish, which is now entirely discontinued. By them the salmon are packed in ice, and sent to London, to be disposed of by factors on commission. This employment of ice was first assayed by Messrs. Richardson, of Perth, on the suggestion of George Dempster, of Dunnicbin, Esq. who had accidentally read that such a practice was not unusual in China.

7050. ROXBURGHSHIRE. 430,048 acres, of which about three-fifths, or 288,048 acres, are in sheep pasture, and the remaining two-fifths, or 172,032 acres, are occasionally under the plough, except about 8000 acres occupied in woods, pleasure-grounds, and the sites of towns and villages. The surface is exceedingly irregular, being in some places ninety, and in others, 2000 feet above the level of the sea. The climate is equally various, and excessive rains, winds, frosts, and even hail and snow are by no means uncommon in spring and harvest. The soil is chiefly moss or peat, but there is also light calcareous soil, clay, and loam. Limestone abounds in most parts of the district, and coal has been found, but is not worked. The agriculture of the arable lands is in all respects the same as that of Berwickshire, and that of the pastures resembles the store farming of the latter county and East Lothian. Dawson, of Frogden, belongs to this county, and may be looked on as one of the greatest improvers of British agriculture. (*Douglas's Roxburghshire*, 1794.)

#### 1. Property.

Generally in large estates, and little change of proprietorship has taken place for many years. The largest about 8000L or 9000L a year.

#### 2. Implements. Arable Land.

Fanners, the reporter states, were first made in this county by one Rogers, a farmer, of a mechanical turn, near Hawick, in 1733, or at least before 1737, who is said either to have seen a model, or a description of one, which had been brought from Holland. (*Report of Northam.*)

Arable land enclosed, partly by hedges and partly by walls of loose stones, without mortar.

Ploughing with two horses, without a driver, was practised in this county before it was in any other. It was taught by Dawson, of Frogden, who introduced the drill culture, to James Macdougall, farmer, at Linton, in Tweeddale, alive at the time of making up the report: it spread rapidly afterwards through the county, and the neighboring ones of Northumberland, Berwickshire, East Lothian, and Tweeddale. Potatoes first planted in large beds about 1754; in 1768, in drills in the fields. Tobacco, during the American war, was cultivated to a considerable extent in the neighborhood of Kelso and Jedburgh, and in some other spots. Its produce was so great, that thirteen acres at Crailing fetched 104L at the low rate of four-pence per pound, and would have brought more than three times as much, had not an Act of Parliament obliged the cultivator to dispose of it to Government at that price. This county lost about 1500L sterling by that Act, which passed while the tobacco was growing; yet it excited not so much murmuring and clamor among the sufferers as has been elsewhere re-

peatedly raised, with less reason, against other Acts in no respect so arbitrary and oppressive.

#### 3. Gardens and Orchards.

Thrive better in the lower parts of this county than in those on the east coast. At Melrose, Jedburgh, and Kelso, are the remains of orchards planted by the priests several centuries ago, the pear-trees of which are very productive. Wonderful stories are told of their fertility. A single tree of the thorn pear at Melrose has for these fifty years past yielded the interest of the money paid for the garden where it stands, and for a house let for seven pounds sterling yearly. Another tree there has carried fruit to the amount of three pounds annually, at an average for the same period. In the year 1793, two trees there brought to perfection about 60,000 pears, which were sold for eight guineas. These facts are well authenticated. There are also several more recent orchards near the same places, and 120 acres of nurseries. Of these one of the oldest and largest in Scotland is that of Messrs. Dicksons, of Hawick.

#### 4. Woods and Plantations.

To the extent of 5290 acres; nearly two-thirds artificial.

#### 5. Live Stock.

Cattle, a mixed breed, as in Berwickshire. Sheep of the Cheviot kind greatly improved by a cross with the Dishley breed, introduced about 1765, by Robson, a pupil of Culey. Merinos and other sorts have been tried, but sufficient time has not elapsed to ascertain the result.

#### 6. Rural and Political Economy.

Farm servants on the same plan as in East Lothian. Roads improving; no canals; little commerce, and almost no manufactures.

7051. SELKIRKSHIRE. 160,600 acres almost wholly of mountainous surface, the lowest part 300 feet above the level of the sea; many houses are 600 and some more than 1000 feet above its level. The highest mountain is 2370 feet. These mountains are generally of granite or whinstone, and the surface soil is commonly gravelly and dry. In the vallies are clay, peat, morass, and lakes. The climate is cold and rather moist. There are no metals, nor coal, lime, or freestone. The most remarkable thing attending this county is that its hills and mountains are almost every where clothed to their summits with sound sheep pasture, of which there are estimated to be 148,000 acres; 8800 acres in aration, 2000 in wood, and the rest in gardens, houses, roads, lakes, &c. (*Douglas's General View*, 1796.)

Property in few hands, and in large estates. The farms are large, and the leases generally shorter than on arable farms. The sheep are a variety of the Cheviot produced by repeated crosses with the native mountain black-faced breed. In all respects the husbandry of this county may be considered the same as that of the mountainous districts of the preceding

counties. There is a woollen cloth manufactory, and an excellent porter brewery, by a pupil of Meux, at Galaahie. Some agricultural societies were attempted in this and the adjoining counties about 1793, but they were of very short duration.

\* 7052. PEEBLESHIRE or TWEEDDALE. 229,778 acres, mostly of mountain, moor, and bog, but with about one-tenth part arable. The lowest part of the county is 400 feet above sea level, and grain is cultivated to the height of 1000 feet. The climate is late, cold, and moist, and the soil moory, clayey, or sandy, according as the water is pent up; and the rocks of the mountains are freestone, granite, trap, or claystone. The only minerals worth notice are lime, whinstone, and freestone. The general appearance of the country is wild, and rather dull and dreary, as romantic or sublime. The agricultural survey of this county is by the Rev. Charles Findlater, and it abounds with more valuable matter on political agriculture, on leases, prices, restrictions, markets, &c. than any survey that has been published, without a single exception. In fact, it was found to take such a masterly view of the moral increments to agricultural industry, that it was rejected by the Board, and the author was reduced to publish it himself. It has certainly, through the medium of the extracts from it published in the *Farmers' Magazine*, been the means of enlightening thousands, both of farmers and landlords. The fundamental principle which Findlater lays down and illustrates under the heads of leases, size of farms, usury, capital, dearth, monopoly, forestalling, government interference, tithes, poor, and other topics, is, "That the best mode of insuring the invention and prosecution of the most advantageous measures is, an arrangement which shall communicate to those on whom their execution is devolved, a sufficient personal interest in their invention and execution." To some he doubts not such views will be considered as foreign to the report of a county; whilst, to others, they will constitute its most essential value.

The state of property and husbandry of the country may be considered as the same as that of the other mountainous districts. The black faced sheep are in almost universal use, excepting in milder situations, where the Cheviot has been introduced. There is no commerce but by retail, and only some very trifling woollen manufactures in the county.

In the Appendix an account is given of the improvement of the Whim, a flow-moss of 100 acres, twenty feet deep, and at an elevation of 700 feet above the level of the sea. It was begun to be drained in 1731, and in ten years a mansion was built, and surrounded by woods and pleasure-grounds, which shew, as the Duke of Buccleugh, the proprietor, intended, the wonderful influence of art over nature. "The plantations (originally extensive) have been improved and enlarged since the property came into possession of the Lord Chief Baron; and he has also greatly enlarged the house, adding a court of offices, upon a large scale, and ornamented in front, extending also the lawn. The place has, upon the whole, an air of magnificence. In the pleasure-grounds, there are several artificial pieces of water. East of the house (where the soil is dry, and covered with sweet grasses) the surface is agreeably diversified by gentle swells, tufted with trees. A wild wilderness walk, through a small wood, lands you upon the banks of an artificial lake, with islands, covering an extent of six or seven acres of surface. What chiefly strikes the visitor at Whim, is the strongly marked contrast betwixt the improvements of human art, and nature in her wildest form, here found in immediate contact. Your ears are, at once, saluted with the warblings of the black-bird and thrush, from the plantations; and the wild notes of the plover, the curlew, the grouse, and other moss birds from the flow-moss." (*Findlater's Report*, &c. 1804.)

7053. DUMFRIESSHIRE, i. 644,385 acres of maritime, vale, and mountain lands, in the proportion of 1, 4, and 7. The climate is variable, comparatively mild, but moist. The soil of the maritime district is light, and generally on sand, gravel, or rock; that of the vale or midland district is gravelly, sandy or moory. The mountains are of schist, whinstone, or red freestone, and thinly covered with corresponding soils or mosses. In some places they are covered with dry pasture, but more frequently with a mixture of grass and heath. The principal metallic ore found in the county is lead; but several others, as iron, copper, antimony, &c. exist, and the latter has been worked. Coal has been found, but not in strata sufficiently thick to be workable. Marble also and slate have been worked, and lime, freestone, and whinstone, in abundance. There are several mineral springs in the mountain district, the principal of which is the spaw, at Moffat. Fish, and especially salmon, are caught in moderate quantities in the Nith and Annan. The celebrated improver, Craik, was a proprietor in this county, at Ardbigland, near Dumfries, now the property of his son. (*Dr. Singer's General View*, 1812.)

### 1. Minerals.

The lead mines occupy very barren grounds, remarkably bleak and elevated; but they are a great fund of industry and riches, and they furnish a part of the county with an excellent market for the surplus grain produced in that part. Lead-hills, with the mines, are in the county of Lanark, and belong to the Earl of Hopetown, who draws about 7000*l.* a year from these mines. Wanlockhead mine is in Dumfriesshire, belongs to the Duke of Queensberry, and returns to the proprietor near 5000*l.* a year.

### 2. Property

In large estates, owned by 453 persons. The Duke of Buccleugh's estate of very great extent. Some estates are managed by their owners, and others by commissioners having power to let. In large properties it is common to entrust the collecting rents, and arrangements relative to leases, buildings, fences, and courses of crops, to factors residing on or near the lands, who represent their constituents (if not personally present) in county and parish meetings. Millar, of Dalswinton, has gone over an estate of 5000 acres, in twenty-five years, and improved the whole of it, with the exception of a portion which is now under process, and promises to be soon completed. His plan is, not to farm his lands himself, but to prepare them, by improvement, for being let to farmers.

### 3. Buildings.

While the reporter expatiates on the ample accommodations of the modern farm-houses in this and other counties, he gives the following information as to cottages, which we regret to find seem by no means improved either in this or in other parts of Scotland in the same ratio as the habitations of inferior animals. "A common, and not inconvenient cottage, is put up as follows; viz., stone and lime walls, seven feet high, thirty-six feet long, and fourteen to sixteen feet wide within; the roof of Scots fir, which is preserved from the worm by smoke, and covered with thatch; a chimney at one end, and an open passage for smoke in the other; affording two apartments below, one of them a kitchen, and a central apartment opposite to the door; the one end boarded over, and the other open. Such a cottage may be erected for about 30*l.* or 40*l.*; and, with half a rood for a garden, it would let at 3*l.* a year or more, according to its finishing." Doubtless the reverend gentleman makes but short prayers when he visits the sick in such smoky cottages:—the surgeon may speak to his patient through the window.

### 4. Occupation.

Sheep farms from 300 to 3000 acres; arable farms from 50 to 600 acres. Leases universal, and generally for nineteen or twenty-one years. Wilkie's variation of Small's plough is in general use, as clearing the mould-beds better in soft soils. The Berwickshire system of culture is practised on the turnip soils; the East Lothian on such as are loamy or clayey; and the stone system on the mountain district. The cattle are of the Galloway breed, and sheep, Cheviots, or the black faced mountain kind. More poultry is kept than in most other counties, in order to consume the light grain. Many of the fowls and eggs go to Edinburgh; but the greater part of the produce and sales in eggs go in small oval baskets, packed in carts, to Berwick, for the London market. In one or two instances the *holcus lanatus* has been cultivated on reclaimed bogs with success, but is intended to be succeeded by better grasses as soon as they will bear them. The drill culture of turnips was introduced by Craik, about 1745. Draining has been extensively practised in many places, and some of the embankments made on the Solway Firth, and the Nith and Annan. There are few orchards. Some remains of coppice and forest, which, according to appearances and authentic records, seem in former times to have spread over great part of the county; and numerous young plantations. Some years ago many young Scotch fir died from the attacks of the *Teredo pisorum*, as some suppose; but the cause does not seem clearly

known. Some very large oaks, beeches, elms, ashes, and larch firs, are described in the report.

### 5. Improvements.

As a specimen we shall give some notices of what has been done on the estate of Mount Annan, by Gen. Dirom. The extent of Mount Annan estate is 2750 acres. The major began his improvements in 1793, and planned before 1819, 168 acres. Assisted in laying out a considerable extent of public road and building bridges, the road passing through the estate. Made an improvement in the construction of lime kilns, since perfected by Booker, of Dublin, (3589.) The lime quarried and dried by means of a small stream from more elevated lands; this stream being made to turn an overshot wheel, which works two pumps. The village of Bridekirk begun in 1800 (3575.) On the new road, and where the river Annan affords amplefalls for machinery. Farms arranged of different sizes, and three eminent farmers settled with a view to improvement. Cottage farms one or two; cottages; improved stone, and the demesne farms improved farm buildings; leases for fifteen years; stone quarries opened, others drained and improved; brick clay found, and bricks made; salmon fishery improved. Irrigation, floun, spring wheat, moss composts, moid plough, and steaming apparatus, introduced. A cross-moss-cutting machine, invented by the overseer, Adam Holliday, for cutting the furrows across in improving moor, instead of cross-ploughing, which is not only a very laborious operation, but seldom succeeds in cutting them into small enough pieces, so as to be afterwards easily harrowed. This machine consists of two circular knives, if they may be so called, six inches deep in the blade, with a blunt edge, fixed upon and embracing the whole of the exterior circle of two small broad wheels, and as they go round the knives cut the furrows across. The axle of the smaller wheels are used for these wheels, so that the weight may be increased by loading the box of the frame, if it should be necessary to make the knives cut through the furrows. It is dragged with great ease across the ploughed moor by one horse; and, when it is moist, the furrows are cut through with the greatest facility, in pieces of any length, according to the number of turns taken by the machine. The furrows, when a little dry, are then turned over by the brake (break) harrow, and being all cut into small pieces, are in the best state for being reduced by repeated harrowing, or for being thrown together in heaps and burnt.

### 6. Weekly Reports.

"In carrying on the improvements which have been mentioned, at a considerable distance from my general residence, they have been greatly facilitated by requiring my overseer, or manager, to send me a weekly report of what was doing upon the farm and the estate. It shows how the servants and horses have been employed during every day, contains a journal of the weather, and of the progress of different works, and a state of his receipts and disbursements during the week. These reports, besides enabling one to judge of what is doing, and to give any directions that may be necessary, are extremely useful to refer to, and excite the overseer and servants to be diligent in my absence."

Increase of population on the estate in fifteen years, 596; viz. from 175 to 371 inhabitants. Total expense of purchase and improvements up to 1811, 30,000*l.* Clear annual rental at that time, 2000*l.* a year, exclusive of the value of timber and of the mansion, garden, and hot-house, &c. as a gentleman's residence.

### 7. Political Economy.

Improving roads, and some canals and railways; some commerce by sea with the port of Dumfries; manufactures inconsiderable; paper, stockings by frames, muslin weavers. A small iron-works at Kirkconnell, in which from three to four dozen spades daily are made. Cotton spinning and weaving in a few places. Carpet weaving, &c. "Salt, from the rich est parts of the sea sleech, collected with horse drags, in dry weather in summer, and then placed so as to be washed and filtered, and the brine that runs out of it boiled."



7054. KIRCUDBRIGHTSHIRE, 561,641 acres, and WIGTONSHIRE 305,612 acres, possessing great similarity of agricultural character, have been included in one report, as the district of Galloway. The climate moist, but rather warm; in some parts of Wigtonshire in genial seasons, figs ripen on the open garden walls. The soil and surface of Galloway is exceedingly various. Almost the whole of Wigtonshire is very little elevated above the surface of the sea, but great part of Kircudbrightshire is hilly and mountainous. The better soils are for the most part light, and of this and hazel loam there is a considerable portion in Wigtonshire. In some places in Kircudbrightshire it is clayey or alluvial, and there is a great deal of peat-moss, and bog, as well as improved, or grass bearing peat. The rocks of the county are argillaceous, granite, or whinstone, with some freestone. Some mineral veins have been found; and one of lead, near Gate-House of Fleet, was worked at the expense of the compiler of this work for some time, but without success. In an agricultural point of view, Galloway is chiefly remarkable for its breed of cattle. Gladstone, a millwright, who has invented a reaping machine, and proposed some improvements on the threshing machine, and other implements, is of this district. (*Smith's General View*, 1810.)

### 1. Property.

More divided than in most of the counties of Scotland. Largest estate, 30,000*l.* a year, Earl of Galloway's, in Wigtonshire. Estates in general well managed; landlords in general advance money at five, six, or seven and a half per cent. for buildings, fences, drains, mineral manures, roads, &c. Dunbar, Earl of Selkirk, a disciple of Craik's, one of the first who set the example of improvement, which has been persevered in by the same family to the present time.

### 2. Occupation.

In the moors, where breeding cattle and sheep is the object, farms sometimes seven or eight miles square, some ten or twelve. Arable farms 300 to 600 acres; 200 acres perhaps the average. Leases nineteen or twenty-one years, to which the late Earl of Galloway superadded the tenant's life. "From this two good effects were supposed to result; 1st. That the landlord was freed from the expenses of buildings and repairs. 2dly. That the tenant presuming (as we always do) on the continuance of life, would be disposed to go on with his improvements to the last. There is certainly, however, much liberality in the idea."

### 3. Enclosing.

Galloway dykes (2835*l.*) very generally in use; some useful remarks on the necessity of bonding them sufficiently, and working the coping-stones to a flat under-surface.

### 4. Arable Land.

Till the middle of the eighteenth century, four and sometimes six horses yoked abreast in the old Scotch plough, and tumbrils (carts with low wheels without spokes) and cars in use; now all the improved implements; the husbandry of East Lothian on the alluvial lands and loams, too heavy for turnips; that of Berwickshire on the turnip soils; cattle bred on the mountains and moors; carrots cultivated in some places, and found to answer well forin tried on bogs; some irrigation; embanking near Wigton and at Kircudbright, and much draining; also paring and burning, and various other means of improving bogs and flow mooses tried, in conjunction with draining. Corn in the late districts gaited. (2940*l.*) Barley is a good deal cultivated, and thin hot barley cakes, from dough, baked the same morning, with cattle first with butter, and then with honey, and folded or rolled up (like the tuff of the Abyssinians), form a part of the breakfast bread of all who can afford it in Wigtonshire.

### 5. Orchards,

Rare. "Some proprietors furnish their tenants with fruit-trees for their gardens, when they are willing to sit at the trouble of cultivating them. But, from the scarcity of fruit in the country, and the idea that the plundering of an orchard is a very venial trespass, such as do cultivate them, frequently do not gather the fruits. In this we believe there is nothing peculiar to Galloway. There are a few market gardens and several nurseries."

### 6. Woods and Plantations,

Of a very limited extent, but rapidly increasing. John, Earl of Stair, planted extensively at Mount Kennedy, in the beginning of the eighteenth century; and Douglas, Earl of Selkirk, soon afterwards. The Earl of Galloway, the present Earl of Selkirk, Murray of Broughton, and various others, are great planters.

### 7. Live Stock.

The Galloway breed of cattle is well known. The breeders perhaps, in general, understand the management of cattle as

7055. AYRSHIRE. 664,960 acres of irregular but not mountainous surface, and clayey or mossy soil, under a moist climate; half the county bog, hilly pasture, or waste, and the rest chiefly under alternate grass and corn. The agriculture followed is in great part the dairy system; Dunlop cheese, already described (6353*l.*), being chiefly produced in this county. (*Aiton's General View*, 1811.)

### 1. Minerals.

Coal and limestone to be found in most parts of the county, and there are several kinds of building stone, but no metallic ores worth working, excepting iron. Coal is the staple mineral, and is exported in large quantities to Glasgow and other towns, along the west coast, northward and southward.

### 2. Buildings.

Some good castles and mansions, as Culzean, Loudon, Eglington, &c. Farm buildings are improving, though but slowly. Some neat elevations, and comfortable interiors on Lord Eglington's estates; single, (*fig.* 812*a*), and double (*b*). Each of such cottages is surrounded by a neat garden, containing a pigsty, pump, and bee-house; and the house containing a porch (1), kitchen, oven, and stair to bed rooms (2), parlor (3), store closet (4), bed closet (5), pantry (6), coal closet (7), back entrance (8), and water closet (10), with two garret bed-rooms over.

### 3. Occupation.

Farms small, from 50 to 150 acres, and their culture imperfect and irregular, though rents are high from the population of the manufacturing towns.

well as, or better than, most others in the kingdom. They all know to distinguish a good bull or a good cow from a bad one; and fail not to select from their own stock such as are best adapted for the improvement of the breed: and from this general attention, it no doubt arises, that the cattle in Galloway are pretty uniformly good. But among them have arisen no enthusiasts in the profession; none who have studied it scientifically, or dedicated their talents almost exclusively to this one object. No fair test has yet been given, of what might be done by a proper selection of the choicest individuals of both sexes, for breeders, and uniting them in such a manner, as seemed best calculated to diminish their faults and heighten their properties; by crossing the progeny of these from time to time; and still carefully pursuing proper combinations of the most approved males with the finest females, till the improvement was carried to the greatest perfection of which the breed is susceptible. No Bakewells, no Culleys, no Collings have yet appeared in Galloway; who, with a skill, the result of long study and experience, have united sufficient capital, and by the success of their experiments have made great fortunes, and transmitted their names to the most distant parts of the kingdom. Few of the Galloway cattle (comparatively) are fed for home consumption. Dairying with Ayrshire cows has lately been introduced, and very good Dunlop cheese made.

The sheep for the low districts are of various breeds, those of the highlands the same as in the mountain districts of the counties already described. The South Down is found to answer well in Wigtonshire, and also the Leicester.

Horses. Galloway formerly possessed a breed of horses peculiar to itself, and in high estimation for the saddle; being, though small, exceedingly hardy and active. Accustomed to a rugged and mountainous country, and never employed in the draught, these were sure-footed, and travelled with spirit in very bad roads. They were of a larger size than the ponies of Wales, or the shelties of the north, being from twelve to fourteen hands high. It is reported that this breed originated from Spanish horses, which escaped from a vessel of the Armada, that had been wrecked on the shores of Galloway; but it appears probable from some passages in Shakspeare, that the Galloway horses were in repute at an earlier period. It is much to be regretted that this ancient breed is now almost lost. This has been occasioned chiefly by the desire of farmers to breed horses of greater weight, and better adapted for the draught; and from the little value attached, in times of tranquility, to horses well calculated for predatory excursions. As the soil and climate of Galloway are peculiarly adapted for rearing horses, there cannot be a doubt that under proper management, they would in general become excellent, and add much to the value of its produce. Hitherto few more have been bred than what is necessary to supply the demands of the district.

Swine increasing since the introduction of potatoes; and the prejudice against eating the flesh common to this and most districts of Scotland gradually declining. Ringing not practised, but the two strong tendons of the snout cut by a slight incision, about an inch and a half above the nose, when the animal is about two months old.

Bees of this district produce honey equal, if not superior to any in the world; its excellence supposed to depend on the profusion of wild flowers, especially white clover and heath.

Game abundant; a few ptarmigans in the highest mountains.

### 8. Political Economy.

Roads greatly improved of late, and some cotton, woollen, paper, and other manufactories introduced.

### 4. Live Stock.

Horses are bred and sold under the general name of Lanarkshire or Clydesdale, and are in great demand; as are the Ayrshire cows for the Edinburgh and Glasgow dairymen. Indeed these cows are preferred to all others in most parts of the low country of Scotland.

### 5. Woods and Plantations.

Most of the proprietors are extensive planters. On the Culzean estate are extensive woods, raised in the face of the west winds; most of the trees lean to the east, excepting the common maple, which is generally erect, or nearly so, and is one of the best trees for an exposed sea coast. There are a few native coppice woods, and some fine old birch, ash, and oak trees round Eglington Castle.

### 6. Improvements.

Captain Smith, the proprietor of a small place abounding with peat bogs, about 1790, began to drain and dig, and lime the surface, and succeeded in reducing the peat to a black mould, and rearing tolerable crops of oats, potatoes, and clover. Af-

ter five or six years, he was able to venture horses and cattle on these bogs; but at first every operation was manual.

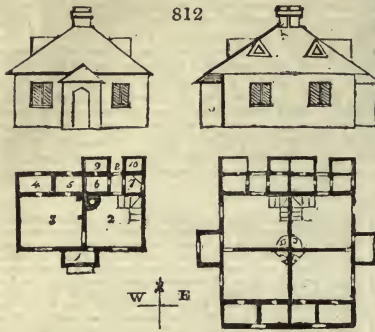

### 7. Political Economy.

Carpet and other woollen manufactures at Kilmarnock; thread at Beith, cotton at Cathrine, iron at Muirkirk, salt and kelp on the shores, and earthenware and the usual minor manufactures, as leather, hats, &c. at various places.

7056. LANARKSHIRE OR CLYDESDALE. 556,800 acres, in great part mountain, moor, and peat-bog, with a portion of friable loam, and some retentive clays. The climate is cold, moist, and unfavorable, excepting in the low vales, where vegetation is chiefly injured by spring and autumn frosts. Average of the rain which falls at Glasgow, 30.8 inches. The minerals are lead, ironstone, coal, limestone, freestone, and whinstone, all worked to a considerable extent. The lead mines at Leadhills, have been already noticed under Dumfriesshire. The husbandry of the county is chiefly distinguished for its breed of horses, and for orchards, the latter a rare production in Scotland. John Naismith, the author of a work on Industry, another on the Elements of Agriculture, and also of the Report, seems to have been a native of this county. (*Naismith's General View*, 1803.)

#### 1. Property.

Three-fourths of the surface, the property of great landholders; the rest much divided. Farm-houses and offices were formerly very indifferent; but in this as in other adjoining counties, when the leases of farms fall in, the landlord generally enlarges or renews the buildings, as a necessary step to getting the full rental value for the land. A good deal of ground fenced out to operative mechanics, weavers, &c. for building cottages.

#### 2. Occupation.

Much the same as in Galloway. Breeding farms are large, and corn farms moderate. The mountainous district is occupied mostly with flocks of sheep: upon the ridges on the E. and W. sides, where the ground is marshy, and less proper for sheep, and the exposure too bleak to encourage the cultivation of corn, cattle are mostly pastured, and those generally milk cows and their young, many of which are reared; a small quantity of corn only being cultivated, principally for the sake of winter provender. The less rugged and less exposed parts are more occupied in the culture of corn; and the banks of the Clyde, between Hamilton and Lanark, with orchards.

#### 3. Gardens and Orchards.

Glasgow is abundantly supplied with the common culinary vegetables from market gardens. Orchards are chiefly found in two districts in Scotland, in Clydesdale, and the Garsc of Gowrie. "The Clydesdale orchards lie mostly between the bottom of the lowest fall of the river, and the mouth of the south Calder. They are chiefly of apples, with a mixture of pear trees, and some plumbs. Cherries are more rarely cultivated, being much subject to the depredations of birds. Few of the orchards are large, but many small ones are planted up and down the country. The whole may cover 540 acres or upwards, and are on the increase. The produce is very precarious, the fruit being frequently destroyed in the blossom, by spring frosts and caterpillars. The value of the fruit is not always in proportion to the number and size of the trees. Those who cultivate the ground around the trees, taking care not to injure the roots, and giving manure from time to time, have finer fruit, and a much greater quantity in proportion, than those who do not. Much also depends on adapting the trees to the soil and exposure. These orchards are mostly planted on very steep hanging banks, and on such they have been found to succeed better than on plains, as subterranean water flows most quickly away. Most of them stand on soils greatly cohesive, and on such the trees have been supposed to be surer bearers than on open sandy soils; yet there are instances of orchards, on friable and gravelly soils, uncommonly

productive. Plumb trees are generally planted round the verge of the orchard, and are profitable, not only for the fruit they bear, but for sheltering the other trees. The depredations committed on the orchards are become more frequent and daring, as the manufactures of the county have increased, and are a great discouragement to this species of cultivation, particularly that of small orchards, which cannot defray the expense of watching in the night."

The harbor, and other works carrying on at Ardrossan, under the auspices of the Earl of Eglington, and the harbor of Troon, and the railway from thence to Kilmarnock, formed almost entirely at the expense of the Duke of Portland, are worthy monuments, no less of the enlightened judgment and energy, than of the wealth of these two patriotic noblemen. The harbor will, when completed, be one of the safest, most capacious, and most accessible on the west coast of Britain; possessing many advantages over the harbors in the Frith of Clyde, situate in a narrow channel, which can be navigated only when the wind blows from particular points, and which, for upwards of twenty miles below Glasgow, is both shallow and dangerous. A circular pier of 900 yards was finished in 1811, and every year was then ready for Glasgow to Ardrossan, which, according to Telford's plan, was to contain from 70 to 100 vessels, in water sixteen feet deep. The works have rather languished of late, and are not likely to be completed soon without public aid. It was part of the Earl of Eglington's plan to raise a neat regular built town at Ardrossan, in which some progress has been made; and he has constructed excellent baths, which draw to it a number of visitors at the proper season.

The harbor at Ardrossan was only a part of the general plan, and that from which, viewed by itself, the smallest advantages perhaps were to be expected. The leading idea was to open up a direct communication between Glasgow, Paisley, and other large towns in the vicinity and the west coast, instead of the present circuitous passage by the Frith of Clyde. A canal was therefore to be cut from Glasgow to Ardrossan, about thirty-one miles and half, at the estimated expense of 125,000*l*. Of this only a third has been yet executed, that is, from Glasgow to Johnstone, and this part has cost about 90,000*l*.

The harbor at Troon, connected, as it now is, with Kilmarnock, by means of an excellent railway, seems to possess almost all the advantages of that of Ardrossan, and promises to become, in a much shorter period, of vast utility to the populous country around it.

Besides the larger fruit, great quantities of gooseberries and currants are cultivated, and, when well managed, are said to pay very well. The gooseberry and currant trees are dug around annually, kept on a single stem, and dunged every second year.

Copses, woods, or native timber trees, are not abundant; the oldest trees are on the Clyde, in and near Hamilton Park and Bothwell Castle. Many new plantations are forming in every part of the county.

#### 4. Live Stock.

Cattle a mixed breed; the Ayrshire beginning to become general. Oxen formerly employed in labor, and still used by a few of the amateurs in spite of the better sense of their tenants and bailiffs. Few sheep kept, excepting on the mountains, where the black faced sort prevails.

The draught horses of Clydesdale have long been in high estimation. Dealers from different parts of England come to the Glasgow and Rutherglen markets to purchase them, and prefer them to the Derbyshire blacks. Those of the upper ward, where the greatest number are bred, are esteemed the best. They have been much improved of late, and are still improving, especially in size and weight.

Hogs. "A kind of Jewish abhorrence of swine seems to have taken place, about the rigid times of the Reformation, in the western counties of Scotland. They were unclean beasts; it was sinful to eat their flesh, and neither credible nor profitable to keep them. And though these prejudices are now pretty much worn out, pork is not yet, in general, a favorite food, and, of course, the number of hogs kept and fed are not considerable."

#### 5. Political Economy.

The roads are in many places bad, but have lately been improved; though the materials be good and abundant, the wet climate is much against them. There are several canals, the river Clyde, navigable to Glasgow, and some railways. The manufactures and commerce of Glasgow are of great extent and well known. There is a corresponding agricultural society there, and some minor societies.

#### 1. Property.

Two large estates; one exceeds 3000*l*. a year. One third of the county under entail, which greatly retards its improvement.

#### 2. Buildings.

More than a common share of elegant villas and gentlemen's

houses. The most magnificent is Roseneath, the Duke of Argyll, built by Bonomi, in 1803*et seq*. It is 184 feet long, and 121 in breadth, with two magnificent fronts, both ornamented with columns of the Ionic order. On his Grace's farm, which is cultivated in a very superior style, there is also a large set of farm offices, surmounted with a high tower. Common farm-

houses and cottages formerly very wretched, beginning to improve, but the progress slow. Dunbarton bridge, 300 feet in length and twenty-five feet high in the centre.

3. *Occupations.*

Average extent of arable farms fifty acres; sheep, or mountain farms, average 600 acres. Farmers men of limited education, without capital, and implicitly following the practices of their forefathers. There exists among the laboring class in this district, an inveterate attachment to the possession of land. When a young man is disposed to marry, he looks out for a small farm, takes it at an extravagant rent, stocks it on credit, and draws from it a scanty subsistence, whilst at the end of his lease his effects are often unequal to pay the debt which has accumulated during its currency. In fact, the feudal state of society has not entirely disappeared in this county. There were lately, on many estates, and are still on some, farms let to three or four tenants, as conjunct lessees, to be cultivated by their united, or rather discordant exertions. Lands always let on lease, seldom for a shorter period than nineteen years.

4. *Implements.*

Curved harrows of a semicircular form are used by the best farmers for dressing their potato ridges. The diameter is equal to the distance between the drills or ridges, generally near three feet, and they are used, before the young shoot of the potato springs, to dress the surface of the ridge, and destroy any weeds which may have begun to appear. The highland hand-harrow is still in use in some corners of the highland district. It is about two feet long and fifteen inches broad, consisting of three balls, and as many cross bars, with twenty-seven teeth, and two handles bent, like a hoop, with which it is wrought. It is employed on bits of land, which have been dug with the highland spade, either on account of their being too steep to be tilled by the labor of a horse, or from their consisting of a number of small corners among rocks and large stones, to which a common harrow could not find access. Wilkie's wheel plough with a shifting muzzle (fig. 813.) is used to clear

813

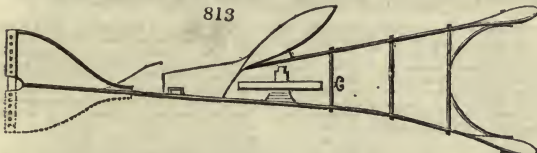

water furrows on wet lands; and also for the common purposes of ploughing strong lands when wet; the muzzle being set so as both horses may walk in the furrow.

5. *Enclosing.*

Gentlemen who pay particular attention to their hedges, never allow them to be cut with shears. In place of that implement, a hedge knife is used, with a short and slightly curved blade, thick in the middle, and tapering to a thin and very sharp edge on each side. By cutting always upwards, the twigs are cut clean over without being bruised or cankered, and the hedge is kept, of what is universally allowed to be the best shape, broad and bushy at the bottom, and contracting to a sharp ridge at top.

6. *Arable Land.*

Potatoes cultivated better than any other crop in the county, and with the greatest success. They are planted on every variety of soil, and thrive even on the stiffest clays where there is a sufficient declivity to carry off the surface water, but a gravelly loam suits them best: about twenty tons of mature per acre, is the common dressing. Drilling and dibbling are the common modes in the lowlands, and by large beds in the uplands; average produce twelve tons, but eighteen are frequently obtained.

7. *Grass Land.*

Some good meadows, but no others; some pasture fields round gentlemen's houses, but none on lowland farms; mountains wholly in natural pasture, moss, heath, bog, and moor.

8. *Woods and Plantations.*

Copsewoods form a very important and prominent article in the produce of this county. They cover some thousands of acres of soil which would otherwise be altogether or nearly useless, and yield an income to the proprietors, little inferior to what they produce from their best arable land. The steep sloping banks of Loch Lomond and Loch Long, where the bases of the mountains run into the lake, are in many places covered with them. The thin dry soil which appears in small patches

7058. STIRLINGSHIRE. 450,560 acres, much diversified by rivers, mountains, woods, and vallies, containing some rich alluvial soil, extensive peat-bogs or mosses, and some bleak hilly districts. The culture of wheat and beans is the chief agricultural feature. Potatoes first cultivated in the fields in this county by Prentice, a farming gardener, at Kilsyth. (*Belsche's General View, 1796.*)

Principal river the Forth, and mountain Benlomond; the latter a cone, upward of 3252 feet high, of sheep-walk, belonging to the Duke of Montrose.

Lime, coal, ironstone, granite, whinstone, and freestone abundant.

The *carse lands* constitute one of the most remarkable soils in the county. They lie in a low situation on the banks of the Forth, and extend about thirty miles in length, and two in breadth at an average. They are elevated from ten to twenty-five feet above the sea level, and a small portion of them in some places is overflowed at times by the river. The soil is universally allowed to be the alluvion deposited by the Forth and its tributary streams, and consequently to be the spoils of the higher grounds, through which the river takes its course. It chiefly consists of a hazel-colored clay, a small quantity of sand, and a pretty large mixture of once organized matter. In some places are patches of till of various colors; but not a stone, so large as to obstruct the plough, is to be

among the rocks, seems to be particularly adapted to the growth of oak coppice, which, from its superior value, is chiefly encouraged in such situations, while the moister and more unfavorable spots are allowed to be occupied by less valuable trees. These are chiefly ash, yew, holly, mountain-ash, birch, hazel, aspen, alder, crab, thorn, and willow. The seven last kinds are considered inferior in value to the rest, and commonly known by the name of barren timber.

Copsewoods are cut from the twenty-second to the twenty-fourth year: after the latter period, the bark of oak becomes hard and corky, and of less value to the tanner.

*Plantations* very generally formed on the uplands. 1000 acres planted at Lass previous to 1794. The Duke of Montrose, a great planter in Stirlingshire, and in this county, allows 200 Scotch pine, 400 larch fir, and 1000 hardwood trees to an acre; prefers oak plants of several years' growth; and after they have been established several years cuts them down, when they push long and strong shoots. Plants by stellate slits, as already described (3668.), as pits in a retentive soil only serve as a receptacle for water. Firs, pines, and all trees now regularly pruned.

The finest tree in the county is an ash in Bonhill churchyard. Its trunk is about nine feet high, and, where smallest, upwards of eighteen feet in circumference. Of the three principal arms into which it branches, the largest is eleven, and the smallest near ten feet in circumference. The branches spread in every direction with uncommon regularity, covering an area of near 100 feet in diameter, and the general aspect is singularly venerable and majestic. There are no data from which its age can be conjectured. Near 100 years ago it was remarked by Marshaw of Stratton, near Norwich, a celebrated planter, as one of the first ashes he had seen; and a tendency to decay in some of the boughs, seems to indicate that it has stood there for several centuries.

Yew trees and hollies abound on the banks of Loch Lomond. A yew at Rosedoc is twelve feet round and very high; one at Stockinlibert twenty-eight feet round, and the top spreading in proportion.

9. *Improvements.*

Some proprietors have drained bogs, and rendered them tolerable meadows; and drained and planted moors. Mosses sometimes burned, the ashes ploughed in, and the land cropped with oats, &c.

*Irrigation* by means of the rills on the hillsides, tried in some places with success.

*Embankments* have been made on a small scale, and some of considerable extent might be formed with success.

10. *Live Stock.*

Highland cattle from Argyleshire in general use; but little feeding, dairying, or breeding of this species of stock. Sheep of a small black faced kind, bred in the county to the extent admitted by the upland pastures. Horses a small, hardy breed.

*Stags* increase as the prejudice against pork disappears. 200 fallow deer occupy two of the largest islands of Loch Lomond. The stag, or red deer of the mountains, has disappeared since the introduction of sheep. A few roes still inhabit the woodlands.

*Bees* common.

11. *Political Economy.*

Manufactures of iron, glass, cotton, paper, alkali, printing and bleaching works, &c.

Window-glass manufactured extensively, and equal in quality to any in the kingdom. Pay 50,000*l.* a year of excise duties; employ 10,000 tons of shipping, and consume 1200 tons of kelp. The distillery of pyrolignous acid, at Milburn, employs about seven hands, and consumes daily a ton of small timber, chiefly oak, from which the liquor, a kind of coarse vinegar, is extracted. The process beautifully simple. A number of iron ovens, or retorts, are placed in a row, and filled with the timber cut into small pieces. A fire of coals or charcoal is kindled in a furnace attached to each, and by its heat forces the acid to fly off in the form of vapor. This vapor is conducted by a small tube proceeding from each retort, into a refrigeratory or long metal pipe, on which a jet of cold water from above is continually falling. Here the acid is condensed, and runs from the end of the pipe in a considerable stream, of a reddish brown color. Besides the liquor thus procured, which is employed in mixing colors for the calico printers, there is a considerable quantity of tar and charcoal produced during the process, the value of which is esteemed equal to the expense of fuel.

found. The soil of the best quality, when dug first from the natural bed, is of a bright blue color, and of a substance resembling the richest soap, and sometimes even serves as a substitute for fuller's earth. In many places the clay is excellently fitted for making bricks, tiles, and a coarse kind of crockery ware. The depths are from five to fifty feet. The subsoils are various, as a stiff brick clay, hard till, and sea-shells in a natural state. These beds of shells are from a few inches to four yards in thickness; they are chiefly large oysters, with a mixture of cockles, whelks, and some other shells at present found in the frith. These lands are in farms from 15 to 100 acres each. In the higher parts of the county the extent is from 20 to 1000 acres.

Of moors above 90,000 acres.

Copple woods extensive, and plantations considerable.

Carron iron works of great extent, and well known. Large cattle fairs held at Falkirk. Chief commerce the shipping of Carron articles for London and other places.

7059. WEST LOTHIAN or LINLITHGOWSHIRE. 71,580 acres of gently varied surface, without hills or mountains; clayey soil, and rather cold and variable climate. The minerals are coal and lime in abundance; freestone, whinstone, and some lead and iron, but the latter are not now worked. The coal at Borrowstonness has been worked for upwards of five centuries. In an agricultural view, this county is of no interest. (*Trotter's General View*, 1811.)

Property is in the hands of about forty proprietors. Lord Stair is supposed to have introduced the culture of clover, turnips, and cabbages, at Newliston, in this county, as early as 1720; and also the Rotheram plough, for which purpose he sent a mechanic to England, to acquire the art of constructing them. A hay drag, of a very simple but convenient construction is used in this county. Plans of a more decent form of cottages (fig. 814.) are given, than are to be found in some reports. Each cottage consists of two rooms (a, b); the one to be used as a kitchen has a space for two press or close beds (c), and in the other room there is a space for one bed (d); in each room is a cupboard (e), but no closet, which is a great defect.

The contrivance for making horses draw equally in threshing machines (2632.), was invented in this county, by G. Henderson, of Bonhard. The culture pursued is the East Lothian husbandry on the clays, and the Berwickshire on the turnip soils. The chief commerce is from the port of Borrowstonness, and there is scarcely any manufactures, unless spinning, knitting, and tambouring, in private families may be named.

7060. CLACKMANNANSHIRE. 30,720 acres, principally of carse land, on the north bank of the river Forth; but partly of hilly district, belonging to the Ochills. (*Erskine's General View*, 1795.)

The carse lands are very fertile; but part of the hilly and moory district of little or no value. The agriculture is similar to that of Stirlingshire. After the invention of the threshing machine, one of the first was erected at Kilbaggie, by George Meikle, in 1787; it is driven by water. A curious source of manure is found in this county. The moss floated down from Blair Drummond (4196.), accumulates in the bays, and is mixed as deposited, by the sea weed driven on shore by the tide. This moss and weed is taken out and fermented with a

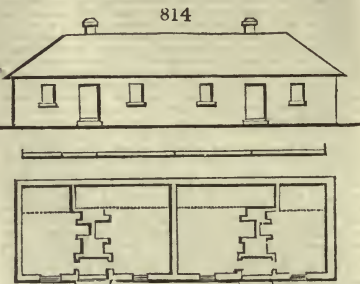

small proportion of stable dung; or the farmers spread it over their cattle yards, and it forms most excellent manure. Thus, what is a complete hindrance to improvement forty miles distant, is brought here by the river at no cost, and forms a most valuable addition to the resources of the cultivator. Till 1760, no wheat was grown in this county, though it appears by old abbey rentals that wheat was paid as rent at Canbus Kenneth, so early as 1147. Now wheat enters into almost every rotation.

7061. KINROSS-SHIRE. 47,642 acres, of varied surface, but generally low. There are extensive mosses and muirs, and not much rich soil. Their agriculture is mixed, and of no great interest. (*Ure's General View*, 1795.)

Locheven occupies 3308 acres; three small streamlets run into it, and the difference between its highest and lowest surface, at different seasons, is three feet. The trout of this lake in high esteem; those of the river Leven larger, weighing five pounds and upwards.

Dr. Coventry, the learned Professor of Agriculture in the University of Edinburgh, possesses an estate in this county,

where he sets an example of knowledge, industry, and good management, to all his neighbors."

Adam, of Blair Adam, the son of the celebrated architect, the most extensive improver in the county; and draining, enclosing, and especially by planting larches, and building commodious cottages.

7062. FIFESHIRE. 322,560 acres, exhibiting almost every variety of surface and soil, from the mountain to the plain, and from gravel to moss. The climate is generally mild, owing to the surrounding waters; and what adds to the value of the county, both for culture and for the formation of country-seats, it is rather drier than that of other counties equally far north. The agriculture is mixed, and may be said to excel both in the corn and cattle department. The reverend reporter displays more than the usual share of adulatory phraseology for that "highly patriotic individual, Sir John Sinclair", our "gracious Sovereign," the Board of Agriculture and the Government, "chalking out to the people a path by which they may rise to opulence and consideration." (*Thomson's General View*, 1 0.)

### 1. Geographical State and Circumstances.

Coal, lime, and the usual rocks abound; iron-stone and lead and copper are also to be met with. Nearer Burntisland, on the shore, and also in some other parts of the county, there are quarries of hard stone, of a dark color, with the peculiar property of resisting the force of fire. It will endure for many years, without being wasted or broken, though exposed to the most intense heat. On this account it is used for the soles of ovens, and for the sides of chimney grates. Common and fire bricks manufactured of an excellent quality. (*Thomson's General View*, 1800.)

### 2. Property.

Estates moderate; largest, 8000*l.* a year.

### 3. Buildings.

Few counties so richly studded with noblemen and gentlemen's houses; about a hundred enumerated as deserving of notice. Many magnificent buildings in ruins. Religious houses, castles, and Falkland Palace. Farm-houses and cottages formerly very bad, now greatly improved, and superior to those in most counties.

### 4. Occupation.

Farms from 50 to 500 acres of arable lands, and some of mountain pastures, are to be met with. Some of the largest and best farmers are men who have emigrated from other counties to this less improved district; but the greater number are sons of local farmers, and not a few farms have been in the same family for several generations. The reporter is an advocate for corn-rents, a mode first revived in this county with the improvement of not taking the corn, but paying in money, according to the average prices. Leases for nineteen years; some formerly for one or more repetitions of the period; in general the restrictions reasonable, for the managers of estates in this county are generally resident factors, and not Edinburgh lawyers.

### 5. Implements.

Ploughs with convex mould boards preferred for loose soils, especially when in a wet state; they free themselves more readily of the earth, and make a neater furrow. An addition to the

plough, called a ridder, (fig. 815 a.) adopted in some places, and found to clear away the stubble from the coulter.

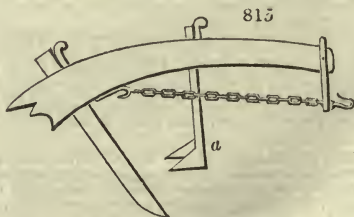

### 6. Grass.

One-fifth of the county inaccessible to the plough, and in store sheep and cattle pasture; some bog or coarse rushey meadows on peat, and a few spots of good alluvial meadow.

### 7. Gardens and Orchards.

The remains of an orchard at Lindores, but none of modern formation. Some market-gardens near the towns, but most of the inhabitants have gardens of their own. Some good nurseries. Sang, an eminent nursery-man, and manager of gentlemen's plantations, — a valuable man to the county — has introduced an excellent system of planting, pruning, and draining. Some of the first private gardens in Scotland are in this county, as that of Keith, Wemyss Castle, &c.

### 8. Woods.

Not extensive, but young plantations very numerous and well managed. More cedars and rare sorts of trees in this county than in any other.

### 9. Live Stock.

Black cattle of Fife long distinguished. The reporter has heard an English dealer say, that a Fife bullock of forty stone will bring an equal, and often a higher, price at the London market than an English bullock ten stone heavier, and equally fat. A good Fife cow will give from five to seven gallons of milk per day; from seven to nine pounds of butter, and from ten to twelve pounds of cheese per week, tron weight, for some months after calving.

Breweries, distilleries, flour and barley mills, frequent. The linen manufacture extensive. Salt made from the sea. Tanneries, vitriol, &c.

The *Fife Farming Society* and the *Inverkeithing Club*, supported chiefly by farmers, are considered useful institutions. The first was formed about six years ago, and at present consists of nearly 200 members. The principal objects aimed at by this institution are, a mutual communication of discoveries and improvements in husbandry; common protection against thieves and depredators who shall unjustly invade their property; and raising a joint stock or capital for the benefit of their widows and children, and of members reduced to distress or indigence. Members pay one guinea at their entry, and half-a-guinea yearly. None are admitted but men of good

character; and such members as shall be found guilty of crimes and misdemeanors punishable by the laws of the land, are liable to expulsion, and a total deprivation of all benefit from the Society's fund. No member can draw any thing from the fund till it amounts to 500*l.*; neither can any one be entitled to any allowance, until five years after his admission. The allowance fixed for a member fallen into distress or indigence, is thirty shillings per quarter; but this allowance is granted upon the express condition, that he has not brought the distress upon himself by drunkenness, or any other kind of disorderly conduct. And during the time he is receiving the allowance, if he shall be found guilty of a dissolute or immoral behavior, it is put in the power of the managers to deprive him of it. The widow of a member is allowed twenty-five shillings quarterly, so long only as she remains his widow, and maintains a good character. And the children, when no widow is left, are entitled to draw the half of what their father contributed. If a member shall die, and leave neither widow nor children, his next heir, or whoever shall be appointed by him, shall be entitled to the half of what he has contributed, after deducting a proportional share of the expenses incurred by the society since his entry. This society is, at present, in a very respectable and flourishing condition.

7663. PERTSHIRE. 4,068,640 acres, almost every where mountainous, but with intervening vales of strong clayey soils, fertile in corn; some gravelly tracts, and many mosses, bogs, and moors. The mountains on the southern side of the county, where they are less high, are covered with pasture to the summits; those in the northern parts with pasture, heath, and copse. The minerals are coal, lime, freestone, slate, whinstone, granite, &c. the metallic ores, iron, lead, and copper, neither of which are at present worked. This county serves to divide that part of Scotland on the south, which is generally adapted to the raising of grain, from that of the north, which, with few exceptions, is more fitted for pasture. It also divides those parts of the kingdom on the north, where firs abounded in former times, and are still found in the mosses, from those in the south, which carried oaks and a variety of other wood, but no natural firs. It is also the general boundary, in regard to coal and granite, though both are found to a moderate extent, the former in the north, and the latter in the south. The husbandry of Perthshire is noted for its clay, or carse land culture, and for its plantations of larch trees. Its great improvers have been, or are, Lord Kaimes, the Duke of Athol, and Lord Bredalbane. (*Dr. Robertson's General View*, 1813.)

### 1. Property.

Estates are of all sizes, but the greater number large. The management of the great estates was uniformly committed in former times to the factor or chamberlain; but agriculture has become so much the amusement of the country gentlemen, since the middle of the last century, that many of the proprietors, besides the general superintendance of their estates, have a farm in their own possession, which they manage by an overseer. Many of our improvements in agriculture are suggested by the gentlemen of the army, in consequence of their remarks on the practice of other countries. The gentlemen of the law, during the recess of their courts of judicature, turn much of their attention to the cultivation of their estates; and their habits of application to the former study, quickens their ardor, and ensures their success in pursuit of the latter.

If the property be extensive, besides an overseer on the landlord's farm, there is generally a factor or steward, and sometimes two or more are appointed to manage the more distant parts of the estate. In these cases, unless the landlord have a turn for business, he is apt to lose sight of the detail of his own affairs; and if he be indolent, he has a good apology for neglecting his interest, because he pays another person for taking that charge off his hand. The prosperity of the estate, and the comfort of the tenants, depend in these cases very much on the disposition of the factor.

The boundaries of estates are marked according to the nature of the country. In the valleys of the Highlands, different properties are separated either by substantial stone-walls without mortar (principally dry, or some dykes), or by a river, or a brook, or a range of rocks, or some other natural limit. The lower hills too are sometimes bisected by these walls; but more generally by bounding stones, fixed in the ground, and set up singly; in other instances, if the stones be small, they are piled in heaps. The higher mountains are frequently divided in a similar manner, especially when different proprietors occupy the southern side; but when they occupy different sides of the same ridge or general line of mountain, as commonly happens between parallel glens, their properties are determined as wind and water divides, which means the line of partition on the top of the mountain between the windward and lee-side, or as it is still more nicely marked by the tendency of rain water, after it falls upon the ground.

A great proportion of this country is freehold. Many of the small proprietors hold of a subject superior. When a great baron in the feudal times had occasion to borrow money, he had recourse to wadsets, or feued off a part of his property at a quit-rent, which was greater or less, according to the amount of the premium that was paid in hand. The wadsets are paid up; but the feus, being irredeemable, remain.

### 2. Occupation.

Arable farms from 30 to 500 acres. Farms in the mountains large, and their extent generally defined by miles. Leases seldom shorter than nineteen years endurance. Rent in a few instances, partly in money and partly in the money value of corn, on an average of two or three by-gone years, according to the modern system. The culture requires scarcely any remark, since there are only two kinds of aration in Scotland, that of the clay soils of East Lothian, in which a fallow and alternate corn and green crops are introduced; and that of Berwickshire, which substitutes turnips for fallow, and allows from two to five years of pasture, according as the soil is weaker or stronger resting crops. A full account of the soil and land culture has been given by Donaldson. In the mountainous region, cattle chiefly, and sheep to a certain extent, are bred and sold for feeding in the low arable districts, and sent to the south of Scotland and England.

### 3. Gardens and Orchards.

In the Carse of Gowrie, a number (perhaps thirty) of orchards of apples and pears, the fruit of which is sold to the neighboring towns. There is another part of the county adapted to open orchards, as the banks of the *Fay Earn*, &c. In the valleys of the Highlands, geans and cherries abound. The trees thrive well, live long, and carry fruit of the finest flavor and most savory taste. The cream colored cherry of Ardvorlich, and

the black gean of Castlemenzies, are highly esteemed in respect of beauty and relish.

### 4. Woods and Plantations.

The Highlands of Scotland formerly covered with wood, as the trunks of oaks and firs in the mosses, from that of Moss-Hunders, near Stirling, to the bogs of Sutherland and Caithness denote the former prove. Planting, according to general use in Perthshire, till after the middle of the eighteenth century. The county is now distinguished by its extensive tracts of larch, common pine, and other trees, and by the enclosure of oak, birch, and hazel; copes and woods formerly left open to the browsing of deer and cattle. Different accounts have been given of the introduction of the larch into this county. Dr. Robertson states it, as said to be brought to Athol, from Carniola, by one of the Dukes of Argyll. According to others, the first plants were obtained from a nursery at Edinburgh, and first sold at Dunkeld in 1741, having been previously introduced into Scotland, by Lord Kaimes, in 1734. (*Encyclopedia of Gardening*, 7055.) Some of the first planted larches in the low grounds, near Dunkeld, have grown to the height of 120 feet in fifty years, which gives an average of two feet four and a quarter inches a year. It is stated by the Duke of Athol, in a communication to the Horticultural Society, made in June, 1820, that on mountainous tracts, at an elevation of 1500 or 1600 feet, the larch, at eighty years of age, has arrived at a size to produce six loads (300 cubic feet) of timber, appearing in durability and every other quality, to be likely to answer every purpose, both by sea and land. (*Hort. Trans.* iv. 416.)

The largest larches in Perthshire, or perhaps in several counties around it, are at Monzie, the seat of General Campbell, which covers 256 acres. They are five feet in diameter in circumference. There are larches of a great size at Blair Drummond, Glenaeles, Rossie, and many other places in Perthshire. Posts of larch, which had been put into a moist soil about fifteen years ago, seemed still to be fresh and strong. It is only of late that this tree has been generally planted, and its excellence known in this country. It is the most rapid in its growth of any tree we have, and the most valuable species of the pine. It is closer in the pores, has fewer knots, and the wood is more durable than the common pine, and withal it increases double the number of cubical feet, in any given time; which is a singular property. It may vie in growth and profit with the Huntingdon willow, which has been said to buy the horse, before any other tree could buy the saddle.

There is a natural fir wood on the south side of Loch Rannoch, which covers 256 acres. It is now only a few acres on the Bredalbane estate, but there are now only a few plantations in this county, than in all the rest of Scotland. The counties of Dunbarton, Argyll, and Stirling, come next to that of Perth. The copse of oak is cut once in twenty-four or twenty-six years. A few spare trees of the most promising appearance and of the best figure are left at proper distances, from one cutting to another, which sometimes in three or four cuttings, amount to fifteen; are generally spared, without attending to this circumstance, that crooked oak is more eagerly sought after by ship-builders, and brings a higher price, than oak which is straight. Yet, as coppice wood is the object, straight trees injure it least. Scotch oak has been found in general too close in the grain to bend into planks for the sides of ships, and even for the same reason it is found to snap when used as ribs to a ship; its closeness in the grain is the effect of slow growth, owing to frequent checks by early and late frosts.

Before agricultural improvements were so well understood as they are of late, or occupied so much of the attention of all ranks in this country, many moorish tracts of land were deemed incapable of cultivation, or of making a return in any other way equal to their being planted. Proprietors, even in the Carse of Gowrie, and in the Stormont, being actuated by this principle, have been in the habit of planting the waste lands of their estates with Scotch firs. They have now found that this soil, by being wrought, will make good arable land, and will be more profitably employed in tillage. Some thousands of acres have accordingly been cleared; the plantations

rooted up; and the soil subjected to the plough, which now lasts at a progressive rent, in some cases amounting already to twenty shillings the acre. Betwixt Coupar, Angus, and Perth, a tract of thirteen miles, the plantations on two thousand acres, upon both sides of the public road, have been grubbed up; and the operation is still going on, both there and in other places. So powerful is the principle of imitation, that we all go frequently one way until we have gone too far. All men can imitate by example, but all men cannot reason so far as to form a principle of action to themselves. In a certain degree this operation is salutary, but if carried to excess, it will leave the face of the country naked; and, perhaps, in all cases, the cost is not counted, nor the balance fairly stated between the plantation and the produce arising from some poor soils by an arable system; yet it must be admitted, that no trees are equal in value to corn and grass, either to the landlord or the public, where the cultivation of these can be prosecuted with success.

#### 5. Wastes.

The mosses and moors of this county are very extensive, and great and successful efforts have been made for their improvement. The most remarkable is that of Kincardine moss, commenced by the late James Mackenzie, and already described (1196.). Draining, paring and burning, irrigating, embanking, and all the different modes of improving land, have been practised; and some, as draining and burning, to a very considerable extent.

#### 6. Live Stock.

Breeds of cattle very various; none peculiar to the county; Angus, Fife, and Argyle herds, common among the farmers. English, Ayrshire, and most of the approved breeds of the south tried by the proprietors. Breeding is the chief object, and next the butter dairy.

*Sheep.* The ancient breed of sheep in this county were the white faced. They were few in number, compared to the flocks at present; and in the Highlands were housed in cots every night in winter and spring. About forty years ago, the black-faced or mountain breed was introduced from the south, and

7064. ANGUS or FORFARSHIRE. 532,243 acres, one half, or more, of clayey and alluvial lowlands, and the remainder mountain pasture, moor and bog. The climate cold, moist, and variable. It is both an agricultural and manufacturing county, and in respect to antiquities, facilities of further improvement, natural productions, &c. of great interest. The botanic family of Don, are of this county. A most valuable report has been furnished by the Rev. James Headrick, and is the last of the Scotch reports which has been published. (*Headrick's General View*, 1813.)

#### 1. Geographical State and Circumstances.

The *Grampian mountains* abound in mica, which contains topazes, or rock crystals. Quartz, mica, porcelan stone, lead, limestone, slate, jasper, porphyry, breccia, and shell marl occur in various places. The Loch of Forfar abounds with shell marl, which is taken out by scoops, and thrown into boats, by which it is conveyed to the shore. The scoop consists of a large iron scraper, somewhat similar to the Dutch hoe, which has a long wooden handle fastened into it, and a bag of strong leather fastened by whip-cord around its rim. The bag is perforated by small holes, to allow the water to drain off, and has a thong at its bottom, by which it can be turned over, and its contents discharged into the boat. After the boat is firmly fastened by anchors, extended from each end, one man forcibly presses down the scoop to the bottom, by means of a long pole, at the stern of the boat, while another man, by means of a windlass, or wheel and axle, fixed in the opposite end of the boat, drags the scoop along the side of the boat, by a rope attached to it, and then raises it up to the boat's side, where the contents of the bag are emptied into the boat. When the boat has received her load, the marl is thrown out upon a wooden platform at the side of the loch, to drain.

*Sandstone flags* are very abundant in the neighborhood of Arbroath, and are quarried and exported in great quantities. Principal quarry, Carmyle; the flags rise from three to six inches of any portable dimensions. They are called slate stone flags, but are in fact sandstone in plates, coated with scales of mica or tick, of a greyish blue color, and this mica occasions their easy separation from each other. With very thin plates, called slatestones, houses are covered; they are laid in a plaster lime or moss (*Sphagnum palustre*), but they seldom make a roof that is water tight, and slate is now considered cheaper. A most valuable property of the flagstone is, that when laid as pavement on wet soil, they never show this on their upper surface, so that they are excellent for paving kitchens, passages, paths in hot-houses, &c. Coal searching for, at the time the report was printing, but with no great hopes of success, the district being considerably out of the boundary of the known coal fields of Scotland. No minerals worked: various chalybeate springs. No rivers, but a number of streams that are of moderate size. Considerable sea, and some salmon fisheries. The herring fishery has been tried in the open sea, and considerable quantities taken in June, July, and August. Those earliest taken were plump and fat, which shows that all former theories concerning this matter are quite abundant of all fishes, are erroneous, and how much it imports the interest of Great Britain, that the herring fishery should be conducted according to the Dutch method, in the deep sea, and, as in the Isle of Man, from May to September. Garvies or sprats, and spirrings or smelts, abound in the Frith of Tay. The sprats resemble herrings, though of smaller size, and different flavor. They are taken in great quantities at Kincardine, and other places near the junction of the Forth with its estuary, by means of wicker traps, sunk in the ebb of the tide. The smelts are smaller than the sprats, and when fresh, emit a smell resembling that of green rushes; but when fried, emit a delicious food. They are caught during spring, along the Forth, often as far up as the Bridge of Stirling, by nets in the form of baskets, fastened to the ebb of the tide.

Haddocks, whiting, &c. cured by smoke, a practice first suggested by Headrick, the reporter, in an essay published by the Highland Society of Scotland. Dempster, of Dunnichen, in this county, first suggested the idea of conveying salmon to London, packed in ice. Reporter remembers when servants in the neighborhood of Stirling used to stipulate that they should not have salmon more than thrice a week; now they seldom have them once a year.

Every river is said to have its particular breed of salmon. They

bought in, either when lambs, or at a year old. Their numbers have increased beyond all expectation, since that time, over the whole Highlands of Scotland. In gentlemen's enclosures, we see different kinds, according to their fancy, or the superior profit expected from one kind more than others.

*Horses.* The original breed were ponies, twelve to thirteen hands high, and too light for two-horse ploughs. Four of them were used abreast, as is still the case in some remote places. In the parish of Gowrie and other lowland districts, oxen were employed to draw the plough, till about 1779; and the oxen were only employed to harrow in the seed, to carry out the dung, and bring home the corn to the stack-yard. Oxen discharged from the plough, it became necessary to purchase larger horses than were then bred in the county; and the markets of Glasgow, Falkirk, Stirling, and Perth, were resorted to for that purpose; which practice still continues.

At present some Northumberland stallions have been procured by proprietors, and lent to their tenants in order to raise an improved breed.

*Swine.* The prejudice against swine's flesh was such, that not many years ago no Highlander would touch it; that is now fast wearing off; and the culture of swine extending.

There is a *rabbit warren* at Dunkeld, and red deer and roes in one or two places. There are also three or more kinds of fallow deer in the county.

Bees much attended to, and found profitable. Paterson of Castle Huntly used mignonette for his bees, which gives the honey a most delicate flavor. Rosemary does the same. The honey of beans is pale; the honey of heath brown. Their flavor is also different.

#### 7. Political Economy.

Roads wretched before 1745; still only bridle roads in many places of the interior. No canals; salmon fishery to a great extent on the Tay. Linen manufactures, besides many various other manufactures and public works. The principal salmon fishery is rented by Richardson from different proprietors, and for the sum of 7000*l.* a year. There are five others, which produce from 100 to 200*l.* a year.

have recourse to fresh water, to escape the attacks of seals, otters, and porpoises, and to get rid of the sea-louse, a small black animal, whose attacks seem to inflict upon them excruciating tortures. A few gulps of river water, seem either to kill the sea-louse, or to deaden the pain it inflicts. Salmon never enters the river in fresh water than is necessary to effect the purpose, which brought them there; but sometimes they are surprised in the rivers by long droughts, and cannot get over mill-dams, and other obstructions which lie between them and the sea. When this happens, they soon get lean and mangy, and die, their bodies covered with white worms. But in fresh water, they take various kinds of bait, and eagerly catch at flies, and hence become a source of amusement to the angler. During autumn, the salmon always run up the rivers to deposit their spawn.

The spawning of salmon seems to be a very slow and laborious process; and they get very lean, and even become unwholesome food, while they are engaged in it. The scene of this operation is generally where a stream begins to issue from a stagnant pool, over a sandy bottom. They begin by digging a hole in the bottom, by pushing the sand and gravel before them with their snouts, in the direction of the current until they raise it into the form of a bank, which checks the rapidity of the current, while it allows the water to percolate slowly. The male seems to exert himself most in this work; and before its commencement, his snout becomes longer and harder than usual, while before it is finished, it is often worn entirely away. While depositing their spawn, the male and female rub their bellies upon each other; the latter throwing out her roes, or eggs; while the male emits among them a milky juice, which seems to effect their impregnation. After one stratum of eggs is deposited in the artificial hollow described, they cover them with light sand, to prevent them from being washed away by the water; and thus they form alternate layers of eggs and sand, until the hollow be nearly filled up. The eggs being dropped into a hollow place, are warmed into life by the sun's rays, in the spring. The fry being then very small, easily escape from their coverings, and rise to the surface, to acquire the size of small trout, and are called salmon fry, or smolts; which seems to be a contraction of *smelt*. The first flood now washes them into the sea; and they are generally swept from our rivers before the middle of May.

*Salmon trout*, or grilises, which ascend the rivers towards the close of the fishing season, are by some considered a distinct species. During summer, myriads of their young fry are seen constantly ascending the fresh water streams, where they keep near the sides, that they may avoid the current. In places where they meet with interruption, such as behind a mill wheel, they often accumulate in large masses, and frequently make their way up the crevices of the building, or over the dry land, until they reach the stream above, in which they continue their course. The larger eels are caught in this county, where they are descending the streams during autumn, probably to deposit their spawn in the sea.

The observations of the reporter on various other species of fish, and on salmon, and other fisheries, are, like every thing which flows from his pen, new and interesting.

*Fresh water eels*, contrary to the practice of salmon, breed in the sea, and thrive and fatten in the fresh water lakes and ponds. During summer, myriads of their young fry are seen constantly ascending the fresh water streams, where they keep near the sides, that they may avoid the current. In places where they meet with interruption, such as behind a mill wheel, they often accumulate in large masses, and frequently make their way up the crevices of the building, or over the dry land, until they reach the stream above, in which they continue their course. The larger eels are caught in this county, where they are descending the streams during autumn, probably to deposit their spawn in the sea.

The observations of the reporter on various other species of fish, and on salmon, and other fisheries, are, like every thing which flows from his pen, new and interesting.

#### 2. Property.

Much divided, largest estate 12,000*l.* a year: property at an average, changes its proprietor every forty years. During the dark night of superstition, a man could take no step respecting

his property, or his domestic concerns, without having half a dozen, or a score of priests to advise him: and he was obliged to compound for the safety of his soul, and the security of his property, by ample donations to the church. When a man died without granting these donations, it was presumed to be his intention to do so; and what was originally an alms, or favor, was claimed as a right. In our days, a man can hardly venture upon any step of importance, without having a posse of lawyers at his elbow, and after all, often finds himself as far from his purpose, as if he had not employed them.

### 3. Buildings.

Sixty gentlemen's seats enumerated: not many with handsome buildings. Farm-houses and cottages most wretched, and slower of improvement than in most other counties.

### 4. Occupation.

Farms of all sizes, but chiefly small. On the Grampians, estimated by the number of sheep they will maintain.

### 5. Implements.

Old Scotch plough still used in a few remote places, and found an instrument well adapted for breaking up waste land that is encumbered with the roots of shrubs, or with stones. At no remote period, it was usual to yoke four or six horses abreast in this plough. The driver walked backwards before the horses, and struck them in the face to make them come forward. At present this plough is commonly drawn by four, sometimes by six horses, which are yoked in pairs, and the driver walks beside them. But, excepting for the purposes already specified, the plough which was first invented by the late Small, near Dalketh, and from him named Small's plough, is universally used.

A *threshing machine*, of a very peculiar construction, adapted to very high falls of water, erected at Howmuir, by Stirling, an ingenious man; but is not yet perfected, and if it were, could never become general.

A *pick or lever* with a tread, used in the same manner as a fork or spade, for loosening hard earth or gravel: in fact it may be called a one pronged fork.

### 6. Tillage.

Fallowing general. Seed-wheat washed with a ley of soft soap, to remove the smut. Potatoes introduced to the gardens in 1745, but not to the fields for many years afterwards. The late Dr. Walker, Professor of Natural History in the University of Edinburgh, was in the habit, especially during years of scarcity, of using yams in place of bread in his own family. He cut them into thin slices, and either branched them on the fire, or dressed them in the frying-pan with as much butter as prevented the pan from burning. When dressed in this way, their taste was very pleasant; and they were used in all cases where bread is commonly used.

### 7. Gardens and Orchards.

A great prejudice in favor of covering wall trees with

7065. KINCARDINESHIRE or MEARNS. 243,444 acres chiefly of mountain, but containing about one-third of cultivable surface. The climate is severe and chilly. The soil is gravelly, mossy, or clayey, and scarcely any where naturally fertile. The only minerals are lime, found in a few parts, and granite, whin, and freestone. Improvements commenced in this county about the middle of the eighteenth century, and have since been carried on with great spirit. (*Robertson's General View, 1795.*)

### 1. Property.

— In few hands: largest estate 40,715 acres, the rest in eighty or ninety estates.

### 2. Buildings.

Some old farm-houses still remain, built of stone and turf, and in all respects wretched; but as leases are renewed, new farmhouses are erected on the most improved plans, with commodious dwelling-houses. So much cannot be said of the cottages, which have undergone very little alteration in structure, for a long tract of time. The habitation of the farmer may have advanced in elegance and accommodation a hundred fold; but the cottages still live in the same simple kind of fabric as his ancestor did in the most remote ages of civilization. A cottage built of stone and turf, or more generally of stone and clay, commonly consists, like the ancient farm-house, of two apartments divided by the furniture. In each of these there is a fire-place and a window. The fire is still without a grate, but the window has two, and in some cases four, panes of glass. The different kinds of cow-cotes, calf-bages, onions, carrots, &c. for the pot, they frequently have rows of gooseberry and currant bushes, together with roses and other flowering shrubs. Some of them decorate the walls of their houses with honeysuckles, or with ivy; and in some instances with cherry and apple trees.

The furniture of a Mearns cottage consists, in general, of two close wooden beds, which are so arranged as to make a separation between two apartments; or of two wooden chests for holding clothes; a cask for holding meal; a set of dairy utensils; an iron pot or two for cooking the victuals; a gridle, or heating iron, for toasting the bread; and a few dishes, some of wood and some of stone ware. Two or three chairs or stools, and a press or cupboard for holding the crockery ware, and the bread, the cheese, the butter, and, at times, the whiskey bottle. A tea equipage, on a small scale, has also of late become an indispensable article of cottage furniture;

7066. ABERDEENSHIRE. 1,270,744 acres, one-sixteenth of Scotland, and one-fiftieth of the area of Great Britain. The surface for the greater part not very irregular, but hilly and mountainous in the district adjoining Inverness-shire: the soil in general than that of Middlesex, owing to the circumambient sea, but the summers short and cold; the agriculture assiduously pursued, and the products chiefly corn and cattle; — great part planted with trees. The report of the county is more than usually intelligent, and contains two preliminary sections, on the lessons which other counties may derive from Aberdeenshire, and on the improvements which this county may derive from others. Aberdeen exhibits a successful example of spade and plough culture combined, in the small holdings of tradesmen, mechanics, cow-keepers and gardeners: and may profit from other counties

nets, to preserve the blossoms from the frost: woolen nets preferred.

### 8. Woods and Plantations.

Few woods, but many plantations. In the mosses the trunks of large trees found.

### 9. Rural Economy.

Farm-servants live chiefly on oatmeal, and potatoes and milk. Their breakfast is porridge, which is made by stirring meal among boiling water, or milk, in a pot over the fire, with a little salt; and when it cools it is eaten with milk. Or they use *brose*, which is made by pouring warm water upon meal, in a wooden dish, with a little salt, taking care to stir it well. This also is eaten with milk, or with beer, which is furnished in place of milk, when the latter is scarce. Sometimes, when they are in a hurry, they mix the liquid with the meal, in a cold state. Their usual dinner is oat cake, with sometimes butter or skimmed milk cheese, and milk. Their supper is the same with breakfast, except that sometimes they use sowens, or potatoes, in the place of porridge or brose. Butcher's meat is only used on particular occasions; and fish by those who are near the rivers and the sea coast.

Much ridicule has been thrown on the Scotch, on account of their immediate use of oatmeal. This has been represented as inflaming their blood, and producing their favorite disease called the *Scotch fiddle*, and other cutaneous eruptions. But oatmeal is as much used in some districts of England, as in any part of Scotland; and cutaneous eruptions are much more frequent in some of these districts than they are here, where they are seldom or ever heard of. The latter ought rather to be ascribed to a dry or scalding than to oatmeal, or any particular species of food. Oatmeal, when it is sufficiently diluted with any sort of liquid, is known to be a laxative aperient, wholesome, and at the same time a strengthening food for those engaged in hard labor. Engineers, who superintend the excavation of canals, have assured the reporter, that those laborers who lived entirely upon oatmeal and milk, did a third more work than those who used butcher-meat, beer, and spirits. All of the former save money, while many of the latter involved themselves in debt. In this sort of work is done by the piece, it affords a fair comparison, not only of the wholesomeness of oatmeal in promoting health, but of its power in supplying labor.

All families that have a house of their own, use tea and wheaten bread. But among cottagers this is a rare, and always a ceremonious entertainment, at christening and other solemn occasions.

Several agricultural societies; the first founded by Dempster of Dunnichen, an eminent improver. An account of the native plants and animals of the county by Don, the celebrated Scotch botanist, who resided at Forfar, possesses great interest for the naturalist. Indeed, the whole survey ranks, in this respect, with that of Farcy of Derbyshire.

for tea drinking has now found its way every where. It seems to be a genteel species of ebriety, which sets the imagination and the tongue at work, without incurring the imputation of drunkenness, or breaking any one precept, human or divine. Wherever it is once introduced, it keeps its ground as certainly as snuff or tobacco, and becomes nearly as inveterate a habit; but happily it serves as an article of food, at the same time that it is a luxurious gratification. The value of a cottage furniture may be estimated at from ten to twenty pounds.

The cottagers are moderate and plain in their food; but they are not so in their clothing. Hardly any thing but English manufacture will serve them. At kirk and at market, it is difficult to distinguish the man from the master, and still more so, the maid servant from her mistress. Either the one or the other have seldom less than five pounds worth of clothes, and often twice that value, on their back at once.

The *village of Laurence-kirk* was founded by the late Lord Gardenstone, about 1760, and in 1781 he procured a charter by which it was declared a burgh of barony. There is an excellent inn here, with a library and museum for the use of the traveller. There is a manufactory of sycamore snuff-boxes; and the lands in the neighborhood have been raised in value from ten shillings to three and four pounds per acre.

### 3. Occupation.

The number of small farms of various sizes; some 400 or 500 acres. Hill pastures let in tracts by the thousand, and one farm occupies 30,000 acres. Leases formerly let on periods of two, three, and four times nineteen years, with sometimes a life-rent after; of late the term seldom exceeds nineteen or twenty-one years, unless when great improvements are expected to be made by the tenants. The arable land is cultivated under judicious rotations, in which either turnips or fallow enters, according as the soil is light or clayey. The mountains are devoted to the breeding of cattle. There are few or no public gardens or orchards, but great extent of young plantations, and some patches of native birch and hazel copse. The cattle are a small, hardy, kindly feeding breed. Horses of the Clydesdale variety are reared by many farmers, and most kinds of improved stock have been tried. Bees are generally kept. There is a good deal of sea fishing, and some valuable salmon fisheries; but excepting ropes, nets, canvass, &c. there are no manufactories of any consequence.

southwards, by greater attention to collecting manure, not employing women and children in the lighter operations of husbandry, and limiting tenants to a certain number of subtenants. The celebrated Dr. James Anderson, farmed extensively in this county, at Mounie, now the property of his eldest son, Alexander Anderson Seaton, a distinguished horticulturist. (*Keith's General View*, 1811.)

### 1. Geographical State and Circumstances.

No metals, or coal, and very little limestone, but abundance of excellent granite; which is used for every sort of building at home, and exported to London in great quantities. Besides the durability, there is one other excellence attending the use of this stone; the expense of carving it has simplified the style of architecture.

### 2. Property.

Much divided, only two or three large estates. Lord Aberdeen's the most valuable, consists of 50,000 arable acres, and 25,000 waste.

### 3. Buildings.

A number of ruined castles and religious buildings, and a few handsome modern houses. An ample descriptive list of gentlemen's seats, which are very numerous. Farm-houses, formerly wretched structures of clay, turf, and thatch, are now greatly improved; cottages improving. "*Deceat Jarmes*" first began to be thought of about 1760. In 1794, Dr. Anderson observes in his report of the county on which the present one is founded, that they are "for the most part very poor. This is," he adds, "highly impolitic. Nothing contributes more to the content and convenience of a farmer, than good and well disposed buildings. It elevates his mind, gives him spirit to pursue his operations with alacrity, and contributes in many instances to augment his profits. I never yet saw a thriving tenant who had not good houses. But on no account should he be induced to expend that stock upon building houses, which should be employed in extending his own proper business. It ought always to be done by the landlord; and, in general, a good set of houses upon a farm, will bring him much greater additional rent than the interest of the money expended upon them. Nothing will prove such an allurement to a farmer as to buy a house, and lease it on equitable terms." Since 1794, when Dr. Anderson wrote the above paragraph, we have got farmers from Berwickshire, Angus, Mearns, and other southern districts, who have taken farms in Aberdeenshire, and many of whom have shown excellent examples in agriculture, as well as improved their own capital; and the native farmers of the county, in consequence of their example, both in asking good houses, and in raising good crops, are now in a much more flourishing situation.

### 4. Occupation.

The greatest diversity in the size of farms; from six acres to thousands; scarcely a mechanic, journeyman or master, who has not a farm of one acre or two, or a garden; besides the produce, they find the labor highly conducive to health, by counteracting the effect of indoor confinement, and prolonged unfavorable bodily postures, or contaminating respiration.

### 5. Implements.

Turnips formerly sown from a small tin box, nine inches long, and one inch square, with two or three holes at one end, through which the operator shook out the seeds; thinned by a part of the blade of an old scythe fastened to a bit of iron like a common hoe; the advantages of the latter are its sharpness, but it is easily broke. A child's cradle rocked by water.

### 6. Enclosures.

Stone fences, or ditches and earthen banks, the common fences; this frees the land from loose stones, which abound every where, or serves to drain it.

### 7. Arable Land.

Potatoes, as well as various other improvements, first introduced to field culture after the calamitous year, 1782: not liked by farmers so well as the turnip. The reporter tried various experiments in distilling from potatoes, which are recorded in the *Farmer's Magazine*. Yellow turnips very much sown, and generally preferred by the cow-keepers. Ruta бага in great repute, but requires to be earlier sown than the yellow, and consequently does not admit of so thoroughly cleaning the ground. Carrot, beet, scorzonera, and other roots fermented and distilled by the reporter, the best spirit and greatest quantity from carrot. White beet grown, but found to yield less produce than turnip, carrot, or cabbage.

### 8. Gardens and Orchards.

The county of Aberdeen is distinguished beyond any other county in the island, for the preparatory branch of all good gardening, viz., *trenching the soil to a proper depth*. We have a numerous class of gardeners in the vicinity of Aberdeen, who cultivate the lands in the neighborhood of that city, and whose practice deserves to be generally known, and generally imitated.

They, in fact, are kitchen gardeners, seedsmen, and nurserymen. They raise all sorts of roots for the inhabitants of the cities of New and Old Aberdeen, various seeds for the use of the country at large, and nurseries so extensive, and so carefully managed, that, besides serving the landed proprietors in the county, and the owners of villas near the towns, they export considerable numbers of plants to England.

A few good private orchards; the largest, that of Ferguson of Pitfour, of ten acres. The site of its nearly 600 years ago, contained the Abbey of Deer, founded in 1218, and the garden belonging to the monastery. It is a striking proof of the luxury of the Romish clergy, and of their uncommon skill in the raising of fruit-trees, that when Ferguson was laying out his new orchard, he found in the Abbey garden, first, rich soil,

above three feet deep; secondly, a well-graded causeway of granite; thirdly, a bed of pure sand, one foot deep; fourthly, another causeway of granite; and below the whole, a considerable depth of rich mould. No greater precaution could have been taken to hinder the roots of the fruit trees from being injured, by piercing into a cold or wet subsoil.

### 9. Woods and Plantations.

In the higher division of Mar, occupy nearly 100 square miles, in some places very thickly planted, and in others raised by nature, at very different distances between the trees. Nearly one-third has been both enclosed and planted; one-third has been raised by nature, without either enclosing or planting the ground; and the remainder has been surrounded by fences for keeping out the cattle, and then been stocked with wood, raised from seed, either blown by the wind, or carried by the rooks, who, by some instinctive impulse, carry the cones of the Scotch pine in their bills, to provide a habitation for their offspring, at a remote period, when the seeds contained in these cones become trees, in which they may build their nests. In these higher districts, wood grows so easily, that the proprietor need only enclose an extent of hilly ground, and thus shut out the cattle. The wind and the crows will in time supply him with seeds. But when these natural woods grow very irregularly, it is found prudent to assist nature, by sowing, or occasional scratching into the soil, a number of seeds of the trees which are wished to be reared in the vacant spaces. The greater proportion of these woods consists of Scotch pine, it grows slowly at first, but is very valuable. Where the soil is most barren, and the trees grow very slowly, the wood of the Scotch pine is of the best quality. A remarkable tree, at Invercauld, was cut down about forty years ago; and the number of concentric circles near its root, viz. 229, showed it to have grown and increased in size, by the exact number of the time that it continued stationary. Its wood was declared, by all who saw it, to be much superior in quality to any that had ever been imported from the north of Europe. There are six thousand of pine trees in Braemar, some of which are nearly six feet in diameter, which are superior in point of quality to any wood of that denomination that was ever imported into any place in Great Britain.

### 10. Improvements.

Trenching above 5000 acres already mentioned: within three miles of Aberdeen, above 6000 acres trenched; some acres paid 50*l.* per acre, for granite boulders for exportation. Practice of trenching very general throughout the county.

Irrigation adopted on poor iron-stone clay, not worth two shillings per acre, but raised in value to two pounds. The operator brought from Gloucester, by Ferguson, of Pitfour.

### 11. Live Stock.

More cattle bred than in any other county. Scotch cattle first improved by crossing some English cows sent down by Henry VII. to his eldest daughter, Queen of James IV. The produce was known as the Falkland breed. Willamson's three brothers sell annually about 3000 head of cattle of various breeds, in the south-country markets. They decidedly prefer the true native, unmixed, and raised by good keeping, to the mixture of the Falkland, or Fifeshire breed, with that of this county; and consider both these to be much superior to the English, or to any foreign breeds. They justly remark, that the food, or keep should be always above the breed, and not the breed above the keep. They consider the south-country highland cattle, which are generally bought by inferior dealers, as too restless and impatient for feeding well. They prefer the native low country breed to the larger ones, as they are most easily maintained, more hardy in work, have flesh of the finest grain, and pay better in proportion to the goodness of their keep. Every succeeding generation, for the last thirty years, has increased in size, and that, by good keeping; the native breed is doubtless a farmer size (not at all the size of the former weight), since the introduction of the turnip husbandry. They are also decidedly of opinion, that wherever a landed proprietor breeds more than one year for family use, the stock should not be tied up, but allowed to feed loose, in order to get gentle exercise along with his food, that the second year he may be put to high feeding, and be tied up, and may be continued with this high feeding as long as he seems to thrive; but that he ought to be killed whenever he loaths his food, or appears to be sickly, or not thriving.

The sheep few, and of a mixed breed. Horses are native ponies, or purchased from Clydesdale. Poultry very common; great demand for eggs, both for the Aberdeen and London markets. Red deer in great numbers in Braemar, and roes in the hills of Cromar.

### 12. Manufactures.

County long celebrated for its woollen manufactures. About 1660 Garden, of Gilconeston, a wealthy sheep farmer and manufacturer, had a daughter, who married Lieutenant Cadogan of Cromwell's army, who afterwards was made a peer, and from whom sprang the Dukes of Richmond and Gloucester, Lords Cadogan, Verney, Holland, C. J. Fox, and other eminent English families.

Woollen, linen, and cotton, now extensively manufactured. Knitting of stockings and spinning lint formerly common, but little attended to since the introduction of machinery.

7067. NAIRNSHIRE and MORAYSHIRE. Forming together 512,000 acres of mountainous surface, and some narrow arable vales, are included in one survey. The climate along the Moray Frith has always been noted for its mildness, which is partly owing to its localities, and partly to the general prevalence of a dry sandy soil. On the mountains the climate is more severe. Lead, iron, lime, marl, freestone, slate, &c. are found, but the two first are not worked at all, and of the others, only the freestone, to any extent. (*Lister's General View*, 1810.)

### 1. Property

In very large estates, as for example, those of the Duke of Gordon, and Earls of Findlater, Moray, Fife, and Lord Cawdor.

### 2. Buildings.

Considerable as has been the alterations in the houses of proprietors, it is nothing to that which has taken place in those

of farmers. Prior to the year 1760, in the dwellings of tenants there were neither floors, ceilings, nor chimneys. In a few of them, the low wall was rudely raised of stone, and clay mortar, and a small glass window; in one only of the apartments was any plaster, and it was raked over the walls in the most artless manner; a loft, on which the roof rested without



any sidewall, distinguished a very few of the most respectable habitations. There was, in general, but one fire (which served all domestic occasions) in the apartment, where the servants and master, with his wife and maiden daughters, lived and fed together. In the higher parts of the district matters were much worse. Now upon every farm of any consideration, the buildings are substantial, commodious, and neat.

### 3. Occupation,

As in Kincardineshire; but the arable lands being generally light, the turnip husbandry is more prevalent. It is a singular fact, that in an island in a lake, Lochgumbrach, in this county, the turnip is found more plentiful in a wild state than in any where else in Britain. This island contains a fortress, and the reporter conjectures that turnips being introduced at an early period from the continent, the small plot of ground within the walls could not be occupied by any crop more convenient for its temporary inhabitants, than that of turnips and coleworts. It may be conjectured that the last crop, probably sown from 300 to 400 years ago, had never been gathered. Until of late the turnips in this island spring up annually in a thick bed, without culture. The root, in some favored situations, it is said, had been found of one pound weight, but they resemble in general the wild kind, having a long root, like a small radish, of acid juice, and a rough pointed leaf. Some plants of red cabbage were also distinguished among them. Both were used as pot herbs at the tables of the country people, on which account they were sometimes raised in their gardens. When they began to run to

seed on this island, young cattle were ferried in to feed on them. The Rev. Francis Forbes, minister of Grange, has seen remains of the family of Grangyvar, from which it appears that turnips were paid as an article of rent in the end of the seventeenth century. The quantity (about 300 bushels) shows that they must have been applied as food for cattle. By the famine which unfortunately took place at that period, however, every agricultural branch of industry was so deranged, that this important object, instead of being extended, was, even there, wholly abandoned.

The cultivation of turnips, as a food for cattle, was first introduced into this district, from the county of Norfolk, by the late Earl of Findlater, about the year 1760.

When the artificial grasses and herbage plants were introduced, only regular gardeners were employed to sow them; now common country operatives perform the operation. Few orchards; apples imported from England; a few natural woods, and extensive artificial plantations. In general it may be observed that in this as in the other counties of the North, every description of improvement has been tried, and success are found to answer, as draining, burning, irrigation, planting, road making, &c. carried to a great extent. All the improved implements have been tried, and the reporter even proposes an addition to them, in the form of circular harrows; the circle of cast iron, and the tines of wrought iron, screwed in or fastened with nuts and screws. (See fig. 776.) There is a good deal of fishing carried on along the coast and in the Moray Frith.

7068. The shires of ROSS, NAIRN, and CROMARTY, are three adjoining mountainous districts, containing 2,204,300 acres. The soil is in general light, sandy, or peaty. Minerals of various kinds have been found, but only building stones and lime are worked. (*Mackenzie's General View*, 1810.)

### 1. Property.

Is in few hands, and till of late underwent but few changes. There are no sources of information from which a precise knowledge of the state of agriculture in these and other northern counties, previous to the rebellion in the year 1745, can be derived; but from what it has been since that time, until about 1760, it may safely be concluded, that agricultural knowledge was neither sought for nor desired. The mode of management which has been practised in these counties, and in other parts of the Highlands, and which has been handed down from father to son for many generations, is still to be found in the midst of the most improved districts. We still see the arable land divided into small crofts, and many of the hills occupied as commons. On the west coast, particularly, the ground is seen covered with heaps of stones, and large quantities are collected on the divisions between the fields, so that a considerable portion of the land capable of cultivation, is thus rendered useless, by the indulgence of the most unpardonable sloth. The management of the native farmers is most destructive. The soil of one field is dug away to be laid upon another; and crop succeeds crop, until the land refuses to yield any thing. It is then allowed to rest for a season, and the weeds get time to multiply. Such, we must suppose, was the system of farming before the rebellion; we cannot imagine it to have been worse.

### 2. Buildings.

The old Highland tenantry are universally ill accommodated. They live in the midst of filth and smoke; that is their choice. But wherever farms have been laid out on a proper scale, and are occupied by substantial and well educated men, we find the farm-houses and offices handsome and commodious. Every proprietor who wishes to see his estate rapidly improved, will erect suitable buildings at his own expense, before he invites a good tenant to settle upon it. The interest of his money will be always cheerfully paid, and if the

landlord agrees that the repairs shall be made at the mutual expense of himself and his tenant, the latter will thrive, and the former will never have to demand his rent twice. The present race of Highland tenants will yet find themselves much happier, and more comfortable, in the capacity of servants to substantial tenants, than in their present situation. The dwellings of cottagers are not worse than those of the native farmers. The same roof covers men, women, children, cattle, dogs, pigs, poultry, &c. It must afford great pleasure to every lover of his country, to observe the neat cottages that are erecting in every part of the country; but it will be long ere the people will learn the comforts of cleanliness and the use of chimneys. In many places where these have been constructed, the people do not use them, but prefer breaking a hole in the roof of the house, and lighting their fire on the floor. Smoke they say keeps them warm.

The occupation and management of land is the same as in the other mountain districts. Some grain, chiefly oats, is raised in the low grounds, with root and herbage crops, and the pastures are devoted to the breeding of cattle and sheep. Every improvement is tried by the principal proprietors; and enlightened farmers from the south of Scotland, accustomed to breeding, induce to settle on their estates, by high leases and moderate rents. From these the smaller native farmers take an example sooner than they would from the operations of proprietors, which they are apt to consider, as at least of dubious value. When a rent-paying farmer, however, adopts plans new to them, the case is very different. Of woods in this district there are very few, but many plantations have been lately made round gentlemen's seats, especially Lord Seaford's.

The great post-roads in this district have been made in part by Government, and in part by the proprietors. There is a cotton manufactory at Cromarty, and the reporter suggests the idea of manufacturing tar, from the trunks of fir trees found bedded in all the mosses of this and other Highland districts.

7069. CAITHNESS. 395,680 acres, three-eighths of which is deep, mossy, and flat moors, covered with heath; three-eighths mountain, moor, and some hilly pasture, and the remainder in cultivable land, lakes, &c. There is very little wood, either natural or artificial: but excellent lime and freestone. On the whole it is one of the coldest, wettest, and most dreary counties of Scotland; and is in no way remarkable, unless for being the scene of Sir John Sinclair's practical attempts at improvement. Of these the chief seems to have been the enlargement of the town of Thurso: of which, and of various other schemes, ample information is given in the report, and in a number of appendices to it by Sir John himself. (*Henderson's General View*, 1812.)

### 1. Property.

Is in few hands, and the Irish practice of tacksman tenants exists, and has existed from time immemorial in the county. These tacksmen, as they are called, generally occupy a part of the land themselves, and sublet the remainder to the small farmers, for a certain money-rent, payments in grain, customs, and service (the latter in many cases unlimited), so as to have, upon the whole, a surplus rent for the trouble and risk of recovering their rack-rent from the sub-tenants. A few young men from the south of Scotland have been brought to this county, to superintend the proprietor's farms or domains, for the purpose of introducing the practice of modern husbandry; these, from time to time, have taken farms in this county; but whether their agricultural skill was superficial, or that they did not understand the mode of farming best adapted to this cold and moist climate, they have neither increased the crops, nor improved the landlord's farms placed under their direction; nor has their industry or skill produced better crops on their own farms, than what is raised by a similar class of the county farmers, who have never been out of it.

7070. SUTHERLAND. 1,872,000 acres, chiefly of mountain and moor; and a climate about a fortnight later than that of Edinburgh. The greater part of the county is the property of the Marquess of Stafford, whose astonishing, masterly, and successful improvements, have been amply detailed in Loch's work, from which we derived so much information for Staffordshire and Shropshire, and to which we again recur. (*Henderson's General View*, &c. *Loch's Improvements of the Marquess of Stafford*, &c. 1819.)

The estates of Sutherland have only lately undergone that change which began to operate in England as far back as the reign of Henry VII. This change had for its object the creation of a middle class by the depression of the barons, and the raising up of the next class, the numerous farms placed was gradually and successfully accomplished in England by the time of Queen Elizabeth, and in the south of Scotland soon after the union of the two kingdoms: but the Highlands, or

The principal farmers in the county under review, are intelligent gentlemen, who have been for some time in the army, or followed other avocations, either in the southern counties of Scotland, or in England, who work their farms upon the principles of modern agriculture, as practised in the southern counties of Scotland, as far as the state of the county, as to climate, roads, the means of improvement, markets, &c. will admit, but at a much greater expense than is done to the southward, and of course much less benefit to themselves. In general, they have other sources of income, which enable them to live in a social and comfortable state in society: they are better educated than farmers paying a similar rent in England; agricultural knowledge, therefore, is soon inculcated amongst them.

The smaller class of farmers, with but few exceptions, are industrious, sober, sagacious, and moral in their behaviour. They have, unfortunately, a turn for litigation, and expend more money than they ought to do in law, by which their circumstances are often injured.

most northerly counties, underwent no change till the discomfiture of the Pretender, and the abolition of the heritable jurisdictions then existing in the north, in 1747. This invaluable act having brought the Highland chieftains within the pale of the law, and the next class, the numerous farms placed in the hands of the gentlemen of the land, they began rapidly to acquire the same tastes, to be occupied with the same pursuits, to feel the same desires, and to have the same wants as their brethren in the

south. In order, however, to indulge these propensities, and to be able to appear in the capital with due effect, it was necessary that they should convert their estates to that mode of occupation most suited to their circumstances, and from which they could derive the greatest income. Luckily in this, as in every other instance in political economy, the interest of the individual and the prosperity of the state went hand in hand. And the demand for the raw material of wool by the English manufacturers, enabled the Highland proprietor to let his lands for quadruple the amount they ever before produced to him. These arrangements continued to be carried into effect from time to time, in the southern and central Highlands, up to about the commencement of the French revolution war; not always however, without serious resistance on the part of the people.

The northern Highlands still remained to undergo that change

which the rest of the island had already adopted. In this district it naturally began to be followed in the counties situated nearest to those into which it had already been introduced. In Ross-shire, accordingly, it was undertaken on a great scale, in 1792. The dissatisfaction produced was so great, that the most serious affrays took place, and the military had to act, and blood was shed before quiet was restored. Between that time and 1815, the greater portion of the county of Sutherland, not belonging to Lord and Lady Stafford, was arranged according to those plans so universally adopted. This ancient condition of society prevailed longer on the estate of Sutherland, than in any other part of the island, on account of its difficult access across the Dornoch, and other friths, and the total want of roads in the county till 1809. The estate of Sutherland (fig. 816 a, a, a) including the barony of Assynt, (b, b, b)

816



and the late purchases made by the Marquess of Stafford is computed to contain more than 800,000 acres. The estate of Lord Reay (c) is more than half that extent. The residue of the county belongs to different lesser proprietors (d to n).

In 1809 was begun a line of road, conducted according to the best principles of the art, and made in the most perfect manner, from the town of Inverness by Beauly and Dingwall, to the boundaries of the county of Sutherland; two excellent stone bridges, consisting of five arches each, having been built across the Beauly and Conon rivers. The two principal obstructions these roads had to contend with and to surmount, were those which were occasioned by the two friths of Dornoch (fig. 816. 1) and of Loch Fleet (2). The former, especially, presented obstacles of considerable moment, arising out of the width of the channel, and the want of a proper foundation on which to construct a bridge. If the same plan had been followed in this instance, which has been adopted on the two southern ferries, namely, of ascending to the point at which the frith terminates and becomes a river, it would have carried the road so much into the interior, as to counterbalance those advantages which are at all times obtained by the substitution of a bridge in the place of the most perfect ferry which can be established. To avoid either of these inconveniences, a very careful survey of the whole frith was made, and the engineer, Telford, determined to recommend the construction of an iron bridge of magnificent dimensions (See an engraved view in the Ed. Engr.) at Bonar, a point where the frith narrows itself considerably; and above which it again expands, though not to its former dimensions. This structure consists of an extensive embankment, with two stone arches of fifty and sixty feet span respectively; and one iron arch of 150 feet span. It cost 15,971*l.* From this point, the heritors of Sutherland have constructed a road (4, 4) to Tongue (c), the seat of Lord Reay, situated upon the Northern Ocean.

In many places, these roads are cut through the hardest rock; in others they are obliged to be supported on bulwarks of solid masonry. Expensive drains to protect them from the mountain floods, and bridges over the innumerable streams that rush from the hills in every direction, are required. These must be formed of the most durable materials and the best workmanship, to resist the impetuosity of the torrents. No-

thing will set this in so striking a point of view, as to state, that upon the projected road to Assynt, a distance of forty-six miles, three bridges of three arches each, two bridges consisting of one arch of forty feet span, five of twenty feet span, three of twenty-four, six of eighteen, two of twelve, besides many others of inferior dimensions, would be required. On the Stafford estate excellent inns, often combining farmeries, have been built in a number of places at an enormous expense. As an example, we may refer to one (fig. 817.) containing an outer

817

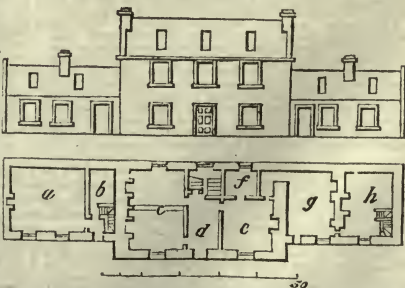

kitchen and servants' stair (d), with a pantry (b), two best parlors, with movable partition for great occasions (c), principal entrance (f), a small parlor (e), small room (f), kitchen (g), back kitchen and servants' stair (h). Over are five bedrooms, and nine garrets for beds.

Thus, in the course of twelve years, has the county of Sutherland been intersected, in some of its most important dis-

tricts, with roads, in point of execution superior to most roads in England. And owing to the equally praiseworthy exertions of the counties of Ross and Inverness, on the one hand, and of Caithness on the other, the same perfect means of communication now exists, from the burgh of Inverness to the town of Thurso upon the North Sea.

Few districts of Scotland possess so small a proportion of land fit for cultivation, compared with its extent, as Sutherland; and previous to the year 1811 but even a small portion of that was brought into cultivation. Each shore is fringed (if the expression may be used) with a narrow border of arable land, which, on the south-east coast, extends from a few hundred yards to about one mile in breadth: the interior consists entirely of mountains.

The lands were let to tacksmen, as in Ireland, till in latter times, when a certain district was let to the whole body of tenants resident in each "town or township," who bound themselves, conjointly and severally, for the payment of the whole rent. This land was held, as expressed in Scotland, "run rig," or like common field land in England.

The effect of this arrangement was to scatter thickly, a hardy but not an industrious race of people up the glens, and over the sides of the various mountains; who, taking advantage of every spot which could be cultivated, and which could with any chance of success be applied to raising a precarious crop of inferior oats, of which they baked their cakes, and of bear, from which they distilled their whiskey, added but little to the industry, and contributed nothing to the wealth of the empire. Impatient of regular and constant work, all the heavy labor was abandoned to the women, who were employed, occasionally, even in dragging the harrow to cover in the seed.

To build their hut, or get in their peats for fuel, or to perform any other occasional labor of the kind, the men were ever ready to assist; but the great proportion of their time, when not in the pursuit of game, or of illegal distillation, was spent in indolence and sloth. Their huts were of the most miserable description. They were built of turf, dug from the most valuable portions of the mountain side. Their roof consisted of the same material, which was supported upon a rude wooden frame, constructed of crooked timber, taken from the natural woods belonging to the proprietor, and of moss-fir dug from the peat bogs. The situation they selected was uniformly on the edge of the cultivated land, and of the mountain pastures. They were placed lengthways, and sloping with the declination of the hill. This position was chosen, in order that all the filth might flow from the habitation without further exertion upon the part of the owner. Under the same roof, and entering at the same door, were kept all the domestic animals belonging to the establishment. The upper portion of the hut was appropriated to the use of the family. In the centre of this upper division was placed the fire, the smoke from which was made to circulate throughout the whole hut, for the purpose of conveying heat into its farthest extremities. The effect being to cover every thing with a black glossy soot, and to produce the most evident injury to the appearance and eyesight of those most exposed to its influence. The floor was the bare earth, except near the fire-place, where it was rudely

paved with rough stones. It was never levelled with much care, and it soon wore into every sort of inequality, according to the hardness of the respective soils of which it was composed. Every hollow formed a receptacle for whatever fluid happened to fall near it, where it remained until absorbed by the earth. It was impossible that it should ever be swept; and when the accumulation of filth rendered the place uninhabitable, another hut was erected in the vicinity of the old one. The old rafters were used in the construction of the new cottage, and that which was abandoned, formed a valuable collection of manure for the next crop.

The introduction of the potatoe, in the first instance, proved no blessing to Sutherland, but only increased this state of wretchedness, inasmuch as its cultivation required less labor.

So long as this system just described remained in full force, no attempt could be made to improve or meliorate the situation of these poor people. To better their condition, however, to raise them from such a state of continual poverty and occasional want; to supply them with the means, and to create in them the habits of industry, was, and is the bounden duty of the owners of every such property. And it was not less their duty to do so, because the same arrangement which was calculated to produce this salutary effect, was at the same time the best suited to increase the value of their property, and to add to the general wealth of the community.

The fundamental principle of agricultural improvement in this case was derived from no speculative reasoning, but from what has actually taken place in a different but similarly circumstanced part of the kingdom.

It is well known that the borders of the two kingdoms were inhabited by a numerous population, who, in their pursuits, manners, and general structure of society, bore a considerable resemblance to that which existed in the Highlands of Scotland.

When the union of the crowns, and those subsequent transactions which arose out of that event, rendered the maintenance of that irregular population not only unnecessary, but a burden to the proprietor to whom the land belonged, the people were removed, and the mountains were covered with sheep. So that it had been for a length of time proved by the experience of the stock farmers of those mountain tracts which comprise the northern districts of England, and the southern parts of Scotland, that such situations were peculiarly suited for the maintenance of this species of stock. Taking this example as their guide, experience had still further proved, that the central and western Highlands of Scotland were equally well calculated for the same end. Reasoning from this success, and observing that the climate of Sutherland, owing to its vicinity to the ocean, and to its being considerably intersected by arms of the sea, and much more moderate than this latter district, it was fairly concluded that this county was even better fitted for this system of management than the heights of Perthshire and Inverness-shire. The inferior elevation of its mountains contributed still further to this effect, and held out every encouragement to adopt the same course which had been pursued with such success in both parts of the kingdom.

The propriety of converting the mountainous parts of the county into sheep-walks was in this way rendered evident, provided the

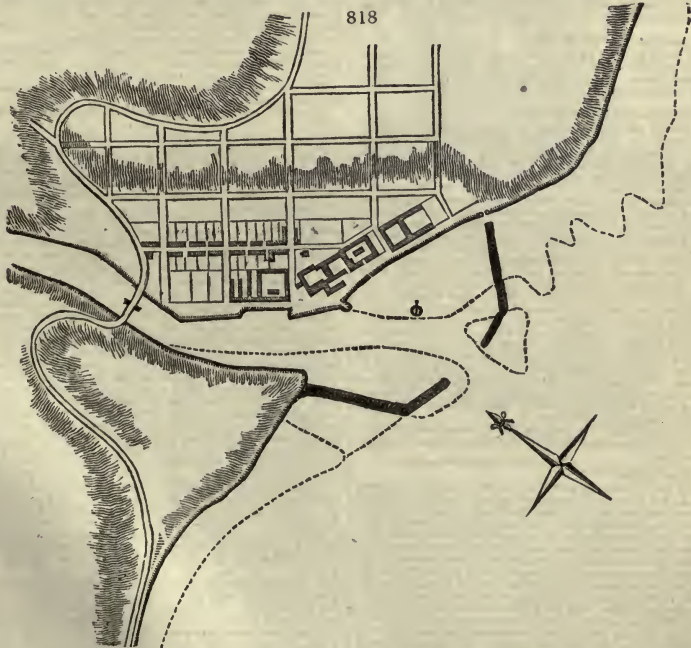

people could be at the same time settled in situations, where, by the exercise of their honest industry, they could obtain a decent livelihood and add to the general mass of national

wealth, and where they should not be exposed to the recurrence of those privations, which so frequently and so terribly afflicted them, when situated among the mountains.

The principle of providing for the lower class of tenants by the establishment of fisheries was thus derived. It had long been known, that the coast of Sutherland abounded with many different kinds of fish, not only sufficient for the consumption of the country, but affording also a supply, to any extent, for more distant markets, or for exportation when cured and salted. Besides the regular and continual supply of white fish, with which the shores thus abound, the coast of Sutherland is annually visited by one of those vast shoals of herrings which frequent the coast of Scotland. It seemed as if it had been pointed out by nature, that the system for this remote district, in order that it might bear its suitable importance in contributing its share to the general stock of the country, was, to convert the mountainous districts into sheep-walks, and to remove the inhabitants to the coast, or to the valleys near the sea. Several sea-ports were improved by the construction of piers (fig. 818 a.) and breakwaters (b); and the plan of a town being formed, the inn, church, post-office, market-place, and other public buildings, were erected by Lord Sutherland, and the most liberal encouragement given by loans of money, grants of land at little or no feu duty, &c. to fishers, manufacturers, tradesmen, &c. both on a large and small scale, to come and

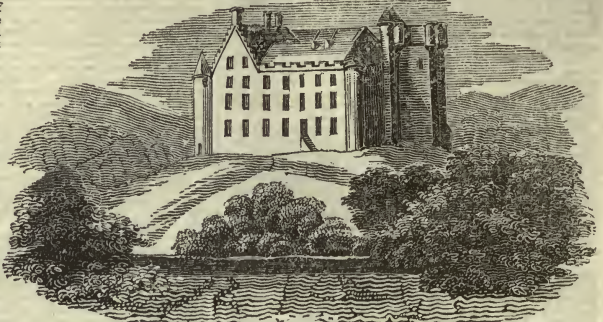

as already observed, (7010.) we consider of very singular agricultural interest.

**7071. INVERNESS-SHIRE.** Upwards of 7,000,000 of by far the most mountainous region in Scotland. It reaches from sea to sea on the main-land, and comprehends many islands, which are scattered far and wide. The hills and moors were formerly covered with fir woods, the remains of which are dug up in all the moors in abundance. The climate is rainy, mild on the west coast, but less so on the east. The soil of the vales is loamy or gravelly. The principal economical minerals are granite, limestone, and slate, but lead, iron, marble, &c. have been found in different places. The county is remarkable for its native fir woods, and for that stupendous national work, the Caledonian Canal, now nearly completed. Improvements were first commenced about Inverness by Cromwell's soldiers. (*Robertson's General View*, 1810.)

#### 1. Property.

In few hands is largest, Lord Macdonald, of the Isle of Skye, the only nobleman who resides in the county. The mountain farms are large, and, as in similar cases, reckoned by miles, or by the number of sheep they are supposed to carry.

#### 2. Gardens and Orchards

To be found in a few places; and some old pear trees, planted by the monks, are still in a bearing state at Beauly, and one or two other places. There is an excellent fruit and forest tree nursery at Inverness.

#### 3. Woods and Plantations.

The Scotch pine, for the most part, took possession of the south side of the valley, and made choice of a northern exposure; the birch, the hazel, and the oak, occupied the warmer side of every district, while the alder and a few ashes ran along the streams. Not only the continental parts had this natural mantle, but the islands of this country appear, from the fragments of trees found in the mosses, to have been at some remote period, mostly, if not wholly, under forests. The only remains of growing wood at present in the islands, are at Portree and Slate, in Skye, and a little in the island of Raasa.

Trees were burned or felled to make room for men, by enlarging the pasturage of cattle, and affording fresh surface for corn. At present the Scotch pine covers more surface in this county, than all the other kinds of trees taken together; and the natural pine woods of Inverness-shire exceed the quantity of this wood growing naturally in all the rest of Britain. In Strathpey alone, it is reported, upon authority which cannot be called into question, that fifteen thousand acres of ground are covered with natural firs. On the south sides of Locharkall, of Glangarry, of Glenmoriston, Strathglas, Glenstrafaras, and at the head of Lochsheil, as mentioned above, the bounds of country under this wood are reckoned by miles, not by acres. The oak woods of this county are not so large, nor so well taken care of, as they are in Perthshire.

There are extensive birch woods, the timber of which is used for fencing and the coarser articles of husbandry, and the bark for tanning.

#### 4. Live Stock.

Cattle are of the Skye or Kyloe breed, usually, however, known as the Highland breed, and already described. (6120.) The cows yield only half the quantity of milk of the breeds of the low counties; generally from two to two and a half gallons; but it is rich, and productive of butter of excellent flavor. The diseases of Highland cattle are few. The manner of disposing of cattle is as follows: When the drovers, from the south and interior of Scotland, make their appearance in the Highlands, which always happens during the latter end of April, or the beginning of May, they give intimation at the churches, that upon a particular day, and in a central place of the district, they are ready to purchase cattle from any who offer them for sale. The drovers are of two descriptions: either those who buy by commission for persons of capital, who, being diffident of their own skill, or averse from fatigue, choose to remain at home; or those who purchase cattle on their own account. Much address is used on both sides, to feel the pulse of the market at these parochial meetings, before the price of the season

settle there. Such is the policy of Lord Stafford's operations, in which he has expended, and continues to expend, independently of the cost of improvements on the mansion (fig. 819.) and park of Dunrobin, immense sums. Happily the success has equalled the most sanguine expectations; but for the very interesting details of execution, our limits oblige us to refer to the work of Loch, which,

819

be mutually settled; and it may happen, that many such small trysts or meetings take place in different parts of the Highlands, before the price be finally determined. The anxiety on both sides is sometimes so great, that the cattle are given away upon a conditional contract, that if the price rises within a limited time, the seller will receive so much more; but if the lean cattle fall in value, the drover will gain nothing.

Sheep are extensively reared, and generally of the Linton or Lammermur black faced sort. The Cheviots are also very prevalent.

Horses either the native pony, or improved breeds from the low countries farther south.

Rees are frequent in a wild state in all the woody and warm glens.

#### 5. Political Economy.

Roads and bridges have been going forward at the expense of Government, ever since 1745, and earlier, and the Caledonian Canal is well known for its magnitude and the excellence of its execution. There are various fisheries on the lakes and coasts; but few manufactures.

As one of the obstacles to improvement, common to this and the other Highland counties, and indeed to every county, the reporter mentions the stubbornness of the common people, in adhering obstinately to old and slovenly habits, is no inconsiderable obstacle. As men rise in years, the reluctance to make any uncommon exertions, and particularly to introduce a change into any thing, which relates to their personal accommodation, gradually grows upon them. Having been long accustomed to a certain course of employment, of gratification, of lodging, of dress, and of food, they resist strenuously the relinquishment of any of these habits; they move on in the current of human life mechanically, like a wheel, without any apparent alteration in their motion, unless it be accomplished by some external force; and if left to themselves, they never change their course. This propensity to remain the same men, and to retain the same customs, is more unconquerable among the illiterate and ignorant, than among the learned or enlightened part of mankind. By means of society, of conversation, and of reading, the latter acquire an enlargement of the mind, to which the former are strangers; and if they be accustomed to reflect on what they hear and see, they are always more open to conviction. When that mulishness of the vulgar, which is the child of ignorance, takes fast hold of the mind, it becomes so obstinate, that it can seldom or never be removed. Its universality would lead to the opinion, that it is an original principle in the human frame, but its progressive influence, which increaseth with age, and the apology which the vulgar urge in their own defence, that their fathers did such things before them, would imply that it is the effect of imitation.

We cannot, however, hesitate for a moment in pronouncing, that the general prosperity of the world is more promoted by the steadiness of the vulgar, even when it amounts to obstinacy, than it would by fickleness, and a desire of change. The very existence of order, the continuance of established government, the enjoyment of the comforts of society, the sweet dearments of friendship, the exercise of the religious principle, and many of the highest blessings of life, flow from the reluctance against innovation, which, with such inveteracy, resists new modes of cultivation in the management of soil.

7072. ARGYLESHERE, nearly two millions of acres; the eleventh part of Scotland, and the thirtieth of Great Britain, and nearly the whole of the Scottish kingdom from A. D. 503 to the subjugation of the Picts in 843. The surface of the country is rough and mountainous; in the northern parts "alps piled on alps hide their heads in the clouds." The climate is moderately mild, very moist in the vales and on the coast, but cold and severe on the elevations. The soil of the vales is generally light; the minerals are lead, iron, coal, freestone, granite, limestone, slates, &c., but the two first are not worked at present. There are numerous bays, inlets, and lakes, in some of which excellent fish is caught. The county is in no respect remarkable in an agricultural point of view: it furnishes immense quantities of cattle and sheep to the graziers and feeders of the south, and there are some oak coppices and artificial plantations. (*Smith's General View*, 1810.)

1. *Property*,

In the hands of 156 owners. Farms of the smaller size reckoned by acres, the largest by miles. One, supposed to be the largest in Britain, is eighteen or twenty in length by three or four miles in breadth; several contain from two to six square miles: object, as in Inverness-shire, the breeding of cattle chiefly, and next sheep.

2. *Improvements*

Have been made by most of the proprietors: some plans of farmeries are given by the reporter. One is circular, and consists chiefly of cattle sheds; but the elevation is of that mongrel Gothic, which is displayed in most of the modern Highland cathedrals. The fin share plough (2499.) was invented in this county by the reporter.

3. *Woods and Plantations.*

There are about 30,000 acres of coppice, chiefly oak, birch, and hazel, which being now valuable for the bark, and the poles to be used as spokes for wheels, is beginning to be enclosed

from the sheep by stone walls. The Duke of Argyle is the chief planter, and his larch plantations are of great extent, and contain an immense quantity of valuable timber. The oldest and largest of the trees at Inverary are supposed to have been planted by the Marquess of Argyle betwixt the years 1650 and 1660. Those of the next largest size and age were raised from the seed by Archibald Duke of Argyle (called a tree-monger, by Walpole) in 1746 or 1747. These consist chiefly of larches, New England pines, spruce and silver fir.

4. *Live Stock.*

Cattle the west Highland breed; the best in the districts of Argyle, Lorn, Ilay, Colonsa, and Mull.

Sheep, till lately, much neglected.

Horses, a hardy native breed larger than the pony.

5. *Political Economy.*

Roads as in Inverness-shire. A canal from the coal works in Campbellton to the sea: few manufactures. An agricultural society at Kintyre.

7073. THE HEBRIDES, including Buteshire, are nearly 200 islands, containing 2,037,760 acres of rocky, hilly, and, in some islands, mountainous country, with a severe, unsteady, moist climate, and a soil generally light. Almost all the minerals are found with which the continental part of Scotland is furnished. Slate, lime, granite, marble, and freestone, are in great abundance, and coal has been found in various places, though it has not been successfully worked. Steatite, or soapstone, from which porcelain is manufactured; fuller's earth, and a great variety of other economical minerals, besides rare and curious species, are found in different islands. (*Headrick's Survey*, 1796. *Macdonald's General View*, 1811.)

1. *Property*

In the hands of forty-nine proprietors; highest rental 18,000*l.* and acres 312,500. A great many tacksmen. Those of Ilay are said to "combine with the spirit and elegant hospitality indigenous in this country, the accuracy in dealing, the punctuality in paying, and all the useful qualifications of first-rate low country farmers. It must not be forgotten, in mentioning the order of tacksmen, that they are exceedingly useful, and often necessary, for maintaining good order and government in the country. Without their aid, the efforts of the clergy and officers of justice would be painful and unavailing; and therefore they ought not to be rashly banished, were they to be viewed in no other light than merely as subsidiary to the police and moral administration of the Isles.

2. *Buildings.*

Farm-houses throughout the Hebrides are either houses of tacksmen, of tenants, or subtenants. Tacksmen's houses, though still far behind those of considerable farmers in the principal counties of England and the lowlands of Scotland, are, however, in general, beginning to be tolerably decent and comfortable; and on all the large estates they have been very much improved within the last twenty-five years. Most of them are now built of stone and lime, and roofed with blue slates, two stories high, and furnished with kitchens and other accommodations. In many instances, indeed, the office-houses are still in a deplorable state, but even these are rapidly improving; and should this order of farmers exist for half a century longer, their houses will, probably, be as commodious, and their office-houses as judiciously planned, as those of the same description of men in any part of Great Britain.

The houses of the occupying tenants are, generally speaking, wretched hovels, and those of the subtenants, nasty and miserable beyond description. Pennant describes them as habitations made of loose stones, without chimneys or doors, excepting the fagot opposed to the wind at one or other of the apertures permitting the smoke to escape in order to prevent the pains of suffocation. Furniture corresponds: a pot-hook hangs from the middle of the roof, with a pot hanging over a grateless fire, filled with fare that may rather be called a permission to exist than a support of vigorous life; the inmates, as may be supposed, lean, wretched, dusky, and smoke-dried.

It cannot be denied, that this picture is, in some degree, realized in a few of the Hebrides, even at the present day.

The cottages in the Hebrides are almost universally so miserable, both in plan and execution, that they deserve mention only as proofs, that a sensible and sagacious race of men may, by a combination of unfavorable circumstances, not only be gradually brought to endure vigorous life, but to their equals in other countries, would seem intolerable, but also, in the course of time, they may lose the power, and even the will of surmounting them. Three-fourths of the 40,000 cottagers of these Isles live in hovels which would disgrace any Indian tribe; and many of them are found on islands of the first rank in point of population and extent. At least, 7000 of the natives of Lewis (for instance) know nothing of a chimney, table, glass window, house flooring, or hearth stone, by their own experience at home; and what we call their furniture is, as may be imagined, wretched and scanty beyond description, corresponding with their shabby exterior.

In the woods of the Park at Bute were formerly fine specimens of Swiss cottages and other fancy wooden buildings. (*fig. 820.*)

3. *Occupation.*

In estimating the size of Hebridean farms, the common plan is to attend to three leading objects; first, the number of live

stock which the farms in question can maintain; secondly, the number of bolts of grain which can be sown, or of ploughs requisite for their tillage; and, thirdly, the quantity of kelp that can be made upon them.

820



"Grazing farms, whether for sheep or cattle, must gradually be enlarged; and kelp, or merely agricultural farms, must as naturally become limited and confined in point of extent. The hay on many of the grass-farms, and sometimes the corn on arable grounds, is obliged to be dried by hanging on poles, trees, or rods, (*fig. 821.*) as in Sweden.

821



4. *Implements.*

Some are nearly peculiar to the Hebrides, as the caschrom or crooked synde (*fig. 822.*), which, in two parishes in the Isle of Lewis, entirely supersedes the use of ploughs in the raising of corn and potatoes. The great advantage of this instrument is, that it enables the operator to work in mosses or bogs, where no horses can walk, and in stony ground inaccessible to the plough. Many districts of Harris and of Skye would be unsusceptible of tillage without it. Its superiority to the common trenching spade, or to any tool which penetrates the ground perpendicularly, is very great, resulting both from the ease with which the operator wields it, and the length of the horizontal clod which its powerful lever enables him to turn over.

The *rattle*, or sickle plough, a sort of paring plough, is used for cutting the strong sward of old land, or the tough roots of plants, which would otherwise greatly impede the passage of the plough.

The *clow-maik*, or wooden tongs, for drawing thistles, &c. differs little from those in use in England. (fig. 254.)



822

### 5. Arable Land.

Tillage is in its infancy over the Hebrides, in all the isles northward of Mull, excepting half a dozen farms in Skye, a part of McLeod, of Rassa's estate, two farms in Ulst, and a little lately done in Lewis, near Stormaway, and by Campbell, of Islay, on a small island between North Uist and Harris. These improvements have been carried on within the last fifteen years.

It would be rather ludicrous than useful to describe the tillage generally practised in the Hebrides; and, accordingly, we shall not dwell upon it, or insult the common sense of the natives, by seriously requesting them to abandon the many barbarous customs which have so long disgraced their country. A man walking backwards, with his face towards four horses abreast, brandishing his cudgel in their noses and eyes, to make them advance to their enemy, followed by a ristle plough employing a horse and two men, the three commonly altogether superfluous, still followed by four horses, dragging clumsy harrows, fixed by hair ropes to their tails, and almost bursting their spinal marrow at every tug and writhing of their tortured carcasses. All this cavalcade, on ground unenclosed, undrained, and yielding at an average little returns for the seed sown, and sometimes lost altogether by the depredations of cattle, or by accident in a late harvest, is a barbarous spectacle, which must gradually vanish. It will soon give way, as it has already done in Islay, Colonsay, and part of Skye, to improved systems of tillage.

### 6. Gardens and Orchards.

It is not to be expected that much should be done in gardening in a district of which by far the greater part of the proprietors are non-resident, nor is the climate suitable for that art. The winds are too violent, and the sun too shy of showing his face. Until trees and other sorts of shelter become, therefore, more general, the gardens and orchards of the Hebrides will probably be little more than an empty name.

### 7. Woods and Plantations.

In the sixteenth century it appears most of these isles were covered with woods, and even so late as Buchanan's time. One exhilarating remark, however, occurs to the traveller who traverses those bleak and woodless recesses, amidst the melancholy impressed upon him by comparing their present aspect with the description which he reads in Buchanan and Monro, namely, that where trees have formerly grown they will grow again; and that any regions which were once sheltered and adorned by the hand of nature, may still be in a far higher degree improved and embellished by the industry of man.

In Bute the late Lord Bute, in Islay Campbell of Shawfield, and in Skye Lord Macdonald, have planted extensively and successfully, and other proprietors are following the example.

### 8. Live Stock.

The ancient Hebridean breed of cattle are now no longer to be found. Some persons imagine it to be the Skye, others the Mull, and others again the Lewis or Long Island variety. A person habituated to accurate observations on cattle, can easily distinguish those different breeds from one another, and all of them from the larger breed now introduced into Islay, Colonsay, and some parts of the Long Island, especially Barra, by

persons who pay attention to so important a department of agrestic economy.

*Sheep.* Only lately attended to. There are now three different breeds in almost all the larger islands, viz. 1. The native aboriginal breed, common to the whole Hebrides, forty years ago, and still more numerous than the other two breeds taken together; 2. The Linton, or black faced sheep of the south of Scotland; and 3. The well known fine-wooled Cheviot breed. The historian Laing, has a large flock of Merinos in the Orkneys.

*Horses.* The Hebridean breed of horses resembles that which we find in almost all countries of the same description of climate and surface. It is small, active, and remarkably durable and hardy. It possesses the prominent marks of perfection in this sort of animal, i. e. it is strong and nimble, of a good form and proper size for its work, healthy, patient, good tempered, and very easily kept in good condition. It is found in the Highlands of Scotland, in Wales, Norway, Sweden, Switzerland, Tyrol, Hungary, and Transylvania, and with little variation in shape and size, in all the hilly districts of Europe. The average height of what are deemed sizeable horses, is from twelve to thirteen hands, but that of the lower tenants horses in Mull, Jura, and the northern isles, rarely exceeds eleven or twelve hands. They are handsomely shaped, have small legs, large manes, little neat heads, and manifest every symptom of activity and strength. The colour is almost grey, bay, and black; the last mentioned color is the favorite. Excepting in Islay and in a few gentlemen's farms, not exceeding two dozen in number in all the Hebrides, very little has hitherto been done for bringing this breed to perfection, or preventing it from degenerating.

The breeding of horses for sale is not carried on to a considerable extent in the Hebrides, nor does any of them export at an average of ten years more than it imports, excepting Islay, and perhaps Arran and Eigg.

*Hogs.* Considerable numbers of hogs are now reared in the Hebrides, where the ancient prejudice against pork has gradually vanished, since their more intimate connexion with the Lowlands of Scotland and England.

*Goats,* still maintain their ground on several islands, and in certain circumstances constitute a valuable stock. But, when their wool is to be reared, and enclosures guarded and preserved with attention, they must be banished; for, being more a browsing than grazing animal, the goat will strain every nerve to crop twigs and plants of every description, and is a mortal enemy to every species of growing woods.

*New species, or varieties of stock.* Excepting the ass, and perhaps the mule, it is not clear that this extensive region would gain by introducing any new sorts of domesticated animals; indeed, the great want felt by the Hebrides is not that of animals, but of food in winter and spring for those which they possess. The native breeds of cows and horses are, perhaps the very best possible for the country to support, and may, by due attention to feeding, and to selecting the strongest and handsomest pairs as breeders, be improved to an indefinite pitch of excellence. The breeds of sheep already recommended and described may be improved, and reared to five times their present numbers, without seriously injuring the agriculture or other interests of the country; and a vast accession of wealth and food might accrue from breeding a competent number of hogs, for which these isles, abounding in potatoes, are extremely well adapted. But all these improvements must go on progressively and slowly, and they must advance in the train of other agricultural and economical improvements.

### 9. Political Economy.

Roads much wanted, and, excepting in Bute, Islay, and Skye, in a very wretched state. No iron railways or canals. No equal portion of European population, not even excepting the Russians, and most uncivilized Poles and Croatsians, possesses so few manufactures, as the people of the western islands of Scotland. This is, among other causes, a principal source of poverty and depression of the people. It makes the little money acquired by the fisheries, and drawn in exchange for black cattle, kelp, and the other productions of the district, continually flow out of it, and prevents that gradual advancement in wealth, comfort, and agricultural and economical improvements, which are conspicuous in all other parts of Scotland; and although it does not absolutely keep these isles in a quiescent state, it greatly retards their progress.

*Kelp,* is a well known Hebridean manufacture, and is in an advancing state. Macdonald, of Staffa, is distinguished for his attentions to this branch of Hebridean economy; and has accordingly preserved for his kelp a character, which enables him to dispose of it at a higher price than the average of the Hebrides obtains. This results principally from its being begun early in summer, its being duly attended to in the carriage and drying of the sea-weeds, and especially its being kept clean and unmixt with clay, sand, stones, and all other impurities, which greatly diminish the value of kelp on many Hebridean estates.

## SECT. IV. Agricultural Survey of Ireland.

7074. IRELAND, the largest island in Europe next to Britain, contains above 20,000,000 of acres, much less varied in surface, soil, and climate, than the latter island. There are several mountainous or hilly districts, chiefly in Ulster in the north, and Munster in the south, and very extensive flat bogs in the middle districts, and upland bogs or moors wherever there are hills or mountains. All these bogs, whether low or high, are on good soil, which, indeed, may be considered in connexion with the moist warm climate as their chief cause. Nine-tenths of the soil is a loam on a limestone bottom, fertile, or capable of being rendered so at little expense; the remainder is chiefly thin clay on limestone. The bogs are here considered as mere coverings to soils; their surface exceeds 1,000,000 of acres. The climate is milder and more equable than that of England; and with the dry soil, as Wakefield remarks, is admirably adapted for pasturage and occasional aration.

7075. Of the agricultural circumstances of Ireland generally, we have already given a

condensed account (803.), and shall here submit some brief notices as to each county. These unavoidably present a degree of sameness incompatible with much interest or instruction. There are agricultural surveys of but a few of the Irish counties, so that we have drawn our resources principally from the copious and highly interesting work of Wakefield, and some more recent statistical writers and tourists.

7076. DUBLIN, 240,000 acres; one eighth in mountain and waste, a tenth in buildings, roads, rivers, &c. and the remainder in arable and pasture. (*Archer's Statistical Survey*, &c. 1801. *Sup. Encyc. Brit.*)

The climate of this county is drier than that of some others; east and north-east winds are less frequent than in England, but storms from the south-west and west are more frequent. Average number of dry days in Dublin for ten years, 179; or nearly half the year wet, and half dry.

The soil is generally shallow, and the substratum almost universally a cold clay. There is very little turf bog in the northern parts, but some considerable tracts among the mountains in the south. No minerals or fossils of much value have been discovered, or are now worked, but there are some good quarries of freestone; limestone, and limestone gravel, abound in various parts.

Landed property in this county is a much more marketable commodity than in most other districts of Ireland. There are here no large territorial domains. Leases vary in their terms, but commonly include a life, for the purpose of creating a vote.

Farms are in general very small near the city, seldom more than twenty or thirty acres; but at a distance, from 50 to 150 acres.

The farm buildings are, for the most part, very insufficient. Near the city, the fences are of white thorn; but in the remote parts, they are nothing more than a bank and ditch. Lime, limestone gravel, and marl, are used as manures. The city of

7077. WICKLOW, 500,000 acres, in great part mountains and bogs, and without inhabitants. (*Fraszer's Survey of Wicklow*, 1801. *Sup. Encyc. Brit.*)

The climate so mild, that the myrtle flourishes in such profusion, as to have been sometimes used for making stable-brooms. The common laurel, Portugal laurel, and arbutus, attain a great size, and can scarcely be recognized to be the same shrubs. Dublin is supplied with early potatoes and house-lamb from the sea-coast of Wicklow, the climate of which, according to Mr. Wakefield, is decidedly different from that of the rest of Ireland. This is the only part of that country where he ever saw grapes growing out of doors.

Metalliferous ores are supposed to abound; copper and lead have been worked, and gold has been found.

There are no navigable rivers or extensive lakes. Some of the streams precipitate themselves from considerable heights, forming beautiful cascades; the most remarkable one is at Powerscourt, where the water falls from a height of 560 feet.

Landed property in the centre of the county in large estates;

7078. WEXFORD, 597,760 acres, mountainous on the north and west, a light soil and tolerable cultivation on the east, and in other parts a cold stiff clay, unimproved by culture. (*Wakefield. Fraxer's Survey of Wexford*, 1801. *Sup. Encyc. Brit.*)

The climate is mild and favorable to the growth of timber, which abounds here more than in most counties. There are some large myrtles in the open gardens.

The landed estates are large, from 2000l. to 10,000l. a year, and into farms of various sizes; but there is little of that minute division which is common in other parts of Ireland; nor are there any rich grazing farms. Dairies are, of which the principal article is butter, are numerous, but generally under bad management. The cows themselves are of a very inferior description; and the same character belongs to their sheep, which forms a very inconsiderable part of the live stock. In their modes of cultivation, however, the farmers here are more advanced than in many other parts of the island. The baronies

Dublin might afford the means of enriching a tract of several miles around it, but its street dung is so little valued, that it is sometimes brought to Scotland by coasting vessels as ballast, and much of it is thrown into the Liffey.

On the arable lands, two crops of wheat in succession, and after these two of oats, without fallow or green crop, are frequently taken, according to Archer. Barley is not cultivated extensively. The natural pastures are, with few exceptions, of an inferior quality. There are few or no flocks of sheep in the possession of farmers. In the city, and within four miles of it, about 1600 cows were kept in May, 1801, according to Archer, where there were formerly near 7000. The old Irish breed of cows is almost extinct, and their place is supplied by the short horns and other breeds from England.

There is a considerable salmon fishery on the Liffey, in which also abundance of eel and pike are caught. There are sea fisheries of herrings, white fish of different kinds, and oysters both in natural and artificial beds; the shells of some of the fed oysters have been found as large as a horse-shoe.

The manufactures of the county are chiefly of linen of different kinds, but they are of little importance. The colonial commerce with Dublin is considerable.

Earl Fitzwilliam's nearly 100,000 acres. The sea coast is much divided and abounds with villas, the temporary residence of the wealthy citizens of Dublin. "It appears to me," says Wakefield, "to contain more gentlemen's seats than the same space in the vicinity of London." The common period of leases is twenty-one years and a life. Potatoes, and all the usual kinds of corn, are cultivated; but turnips, clover, and other ameliorating crops, only partially. Marl, and limestone gravel, are the principal manures. Irrigation is practised. A breed of fine woolled sheep, peculiar to the mountains of this county, exhibit the only traces of a distinct race of short-woolled sheep in Ireland.

The herring fishery in the bay of Wicklow is the best in Ireland after Galway. Flannels are extensively manufactured, but scarcely any linen.

7079. KILKENNY, 510,000 acres mountainous, but with some rich and beautiful vales on the banks of the Barrow, Suir, and Noire, and a climate so mild that in winter the thermometer seldom falls below the freezing point, while in summer it ranges between seventy and seventy-five degrees. There is less humidity than in Dublin and Wicklow, as well as less of the east and north winds. (*Tighe's Survey of Kilkenny*, 1802. *Sup. Encyc. Brit.*)

This county has many romantic situations, ornamented with country seats; and its flat districts, where the tillage farms are more extensive than in most parts of Ireland, present a prospect very different from what is often met with in that country.

The soil is for the most part on limestone, and there are very few bogs. The largest colliery in Ireland is at Castle Coomer, near the northern boundary of the county. It is a stone coal raised in immense pieces, but of a sulphurous quality, which renders it disagreeable, and sometimes noxious, and it is, therefore, less fit for being used in families. For this reason, and also from the great expense at which it is raised, English coal is used in profusion, even within a few miles of the works. There are several quarries of marble, chiefly of a black color, of which a few tons are exported. Excellent sandstone and manganese, and iron and lead ores, have been observed in different parts.

Property in land is in several large estates, and many of a moderate extent, not exceeding a rental of 2000l. a year. The principal proprietors are Lords Bexborough, Clifton, and Ormond. The leases are in general for three lives, and partnership leases are common, though prohibited on one of the largest properties. On this estate the tenant is allowed to transfer his lease to one individual, but not to divide his farm.

Of the husbandry the most important department is the dairy, which extends over the greater part of it. The most considerable dairies are the district called the Welsh, or Walsh Mountains, a tract of dry, grassy land fit for tillage, but still in its natural state, and not enclosed. About 2000 Irish acres of this land were held in 1800 by one family, who kept 120 cows. The cattle are not for the most part housed in winter, and only those that are about the time of calving, get a

little hay on the fields, where the horses also are kept all the year. They fatten pigs to the weight of five hundred weight. The produce of the best dairies is one hundred weight and a half, or three firkins of butter per cow, and each cow requires from one and a half to three Irish acres. The practice of letting cows to dairymen, which is common in Munster, is but little known in Kilkenny, the cows belonging to the dairymen themselves, who, in some situations, breed them on their own farms, and in others prefer buying them at a proper age. Too little attention is paid to cleanliness in their dairies, especially in the northern district; and for this reason, according to Wakefield, though Irish butter, when fresh, is preferable to any in Europe, yet it is in the lowest estimation in the London market, as it is almost always heavily salted, and very frequently tastes smoky, fishy, and tallowy. The cattle of this county are a mixed race from the native breed and the English long-horned, and their sheep have been, in some parts, improved by the Liecesters. The Merinos have been introduced within these few years by Messrs. Nowlan, the proprietors of a woollen factory, who have now 600 of the pure race; and they find that both the quality and the weight of the fleece have improved since the sheep were imported. The usual corn crops are raised here, but clover and other green crops not in a suitable proportion. It is the custom to work oxen intermixed with horses, in teams of six, or three pair, deep, the oxen placed foremost. Yet the fallows are better managed here than in any other part of Ireland. Irrigation has been practised for many years, but not extensively. (*Sup. Encyc. Brit. Kilkenny*.) Salmon are caught in the rivers, and sent to Dublin packed in boxes of ice. Woollen is the chief manufacture. Messrs. Nowlan and Shaw produce excellent superfine cloths, from an establishment as celebrated in Ireland as that of Owen at Lanark is in Scotland.

7080. KILDARE. 392,397 acres, four-fifths arable, meadow, and pasture, and the rest bog. (*Rawson's Survey of Kildare, 1807. Sup. Encyc. Brit.*)

Part of the *Bog of Allen* and other similar tracts occupy a large portion of the western side of the county. The surface is varied by a number of small hills and gentle declivities, but for the most part it is flat and nearly level; and when viewed from a commanding station, presents a rich, and, on the banks of its rivers, a beautiful landscape. The Curragh of Kildare, extending to about 5000 acres, has been long celebrated for the softness of its turf and the fineness of its pastures. But the climate of Kildare is said to be more moist than that of any other part of Ireland, which, if the statement be correct, is a very unfavorable circumstance, as a clay soil prevails very generally, and much of it is exceedingly tenacious of moisture.

There are a few large estates in Kildare, particularly the Duke of Leinster's, which extends over a third of the county; and several proprietors, according to Wakefield, have from 6000*l.* to 7000*l.* a year. Yet many are less considerable, and property

7081. KING'S COUNTY. 457,000 acres, half of it bog, meadow, and pasture, of a medium quality. (*Coote's Agricultural Society, 1801. Sup. Encyc. Brit.*)

The *Bog of Allen* occupies a considerable tract on the north-east coast, and the mountains are on the side of Queen's County. The soil of the arable land is either moorish or gravelly, the former productive in dry, and the latter in moist seasons, but neither of them naturally fertile. Limestone and limestone gravel, the means of their improvement, abound every where. The pastures, though in many parts fine, are not luxuriant; better adapted for sheep than cattle, and very favorable to the growth of fine wool. Much of the mountain district has an argillaceous soil, thickly interspersed with rocks of sandstone, and a deep irremediable bog often occurs at its base; but towards the centre of this range, where limestone prevails, there is much good pasture; and here the base of the hills, which is composed of a stiff clay, produces abundant crops of corn.

Landed property, is in large estates, and many of their owners do not reside; but much of the land is held on leases in perpetuity, and the holders of these form a respectable class. The principal proprietors are Lords Digby, Ross, and Charleville. Farms were formerly very large, not unfrequently of the extent of 2000 acres, but their size has been diminished, and such as are considered large, do not now exceed on an average, 400 English acres. Many are as small as twenty acres, though the medium size of the smaller class may be double this. Most of the arable land is tolerably enclosed, chiefly with hedges of whitethorn, which grows here to a great size. Particular leases and sub-tenancy are less common than in some other parts of Ireland, yet the condition of the tenantry and the peasantry does not seem to be materially more improved. The farm-buildings of every description are generally very bad, the cottages in particular; and yet those who have been long accustomed to these miserable cabins, are said to prefer them to more comfortable dwellings, (*fig. 825.*), which, after having

7082. QUEEN'S COUNTY. 384,000 acres, generally of a level surface, three-fourths of which is of a productive soil cultivated, and the rest, bog and waste. (*Coote's Agricultural Survey, 1801. Sup. Encyc. Brit.*)

Coal of the Kilkenny kind, (7079.) is the only mineral worked; but there is iron ore, freestone, marble, &c. in different parts. The Barrow and Nore are navigable rivers.

Estates are from 5000*l.* to 15,000*l.* a year, and upwards. Some of the most valuable, having been let on perpetual leases, afford a large income to the lessees. It is these lessees who form the middle class of gentry, with clear incomes of from 100*l.* to 800*l.* per annum, obtained from tenants to whom their lands are sublet at rack-rent, and commonly in very small farms. Here, and in King's County, Wakefield observed some

7083. CARLOW. 220,098 acres, of undulating surface, with some hills and mountains; the lowlands, a fertile loam, and the uplands, a light gravel; one-tenth in mountains and bogs. (*Wakefield's Statistical Account, &c. Young's Tour, &c. Sup. Encyc. Brit.*)

The minerals are various, but little known. There are no large estates in this county; and very little minute description of property. The hiring tenant is generally the occupier, except of small pieces. There are some excellent flocks of long woolled sheep. Four sheep of the Irish breed, and five of the English are called a "collop," and three collops are allotted to two acres of the best land. For its dairies, Carlow is not excelled by any county in Ireland. The farmers spare no trouble or expense to procure good cows. From twenty to fifty are generally kept; and, during the season, each cow produces on an average about one hundred weight and a half of butter. The dairy system pursued in Devonshire, Dorsetshire, and some of the northern counties of Ireland, of letting cows to dairymen, is followed here; but this custom was more prevalent when the Catholics could not legally purchase land, as they then employed their capital in hiring cows. The butter made in Carlow is divided into three sorts, according to its quality. The first in point of quality is sent to Dublin and England, and thence exported to the East and West Indies. It is highly esteemed in the London market,

7084. EAST MEATH. 617,600 acres, of low, flat, rich surface; a clayey or loamy soil on limestone or gravel, with little wood, few mansions, and only one-twelfth of bogs. (*Cutrucci's Observations, 1818. Thomson's Survey of Meath, 1802. Sup. Encyc. Brit.*)

The landed property of Meath is divided into large estates, a great many of which yield an income of upwards of 2000*l.* a year. These are for the most part let out on leases of twenty-one years and a life; but on some of them there are leases in

perpetuity, which have now become more valuable than the freehold property.

The common size of farms is from ten Irish acres to 200, and these farms are frequently held in partnership. Large farms, however, are less rare here than in the arable tracts of the other counties: The leases were formerly for thirty-one years, but are now mostly for twenty-one years and one life. All parish and county taxes are paid by the tenant. With few exceptions, the course of cropping is the same as it has been for a century; viz., fallow, wheat, oats. Potatoes are universally cultivated. Oxen are employed in ploughing, and horses for carriages; but in many instances oxen and horses are mixed together in the plough team, which sometimes consists of six, and never less than four animals. A number of mules are also kept on the farms.

There are several streams and two canals. A woollen manufactory at Cellbridge; and a Catholic seminary at Maynooth, for above 200 students.

been erected by some of the proprietors, were for some time allowed to stand uncultivated.

Wheat, oats, barley, and potatoes are the most common crops. The average produce of wheat is no more than sixteen bushels; of barley and oats, it is about thirty-two bushels; and of potatoes, only four tons per acre. Both oxen and horses are employed in labor; the plough is sometimes drawn by only two of either, in a few instances by two heifers, yet this and their other implements are not generally of a good construction. The threshing machine has been in use in this district for about twenty years.

The leases were formerly for thirty-one years, or three lives, but the more common period of late is twenty-one years, to which the life of the tenant in possession at the end of it is frequently added. Some tenants hold for lives renewable for ever, paying a renewal fine equal to half a year's rent, or more, on the fall of every life. Modern leases often contain a prohibition against alienating. Nothing is so much complained of among the tenantry, as the mode in which tithes are collected. There are no considerable manufactures, no fisheries, and no minerals worked.

The manufactures are linen and coarse woollens, but to a great extent.

The best farming in Ireland, with much more attention to a systematic course of cropping, and to keeping the land in good heart. Oxen and horses are used for the plough, the former generally preceding the latter. A good deal of cheese is made here for the Dublin market. In other respects, the rural economy of this district does not differ materially from that of the Irish counties already described.

The manufactures are linen and coarse woollens, but to a great extent.

where it is often sold as Cambridge butter. That of the second quality is exported to Spain, and the worst to Portugal. It is all packed in large casks, weighing upwards of three hundred weight.

There is not much wheat grown, and it is not of a bright color, or very good quality; but the barley of Carlow is excellent; according to Young, the best in Ireland. At the time of his tour, it was the only interior county which produced it; and at present more is grown here than in any other part of the kingdom. It is principally consumed by the illicit distilleries in the north of Ireland, by the breweries and distilleries at Cork, or by the malting houses at Wexford. The potatoes grown in Carlow are excellent. There is little or no flax. The county is tolerably wooded. In the vicinity of Carlow, a great many onions are grown, which are sold all over Ireland.

In Carlow, coarse cloth, reaping hooks, scythes, shears, &c. are made. At Leighlin bridge, is one of the largest corn mills in Ireland, capable of grinding more than 15,000 barrels a year.

perpetuity, which have now become more valuable than the freehold property.

Grazing is, or was, till very lately, a more important object in this county than tillage. Many persons fattened from

823

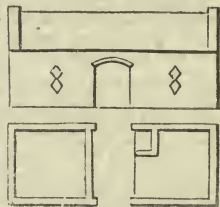



to 600 cows in a season, besides bullocks and sheep. These they purchase at the beginning of the grass season, and dispose of during the summer and autumn, as they are ready, instead of keeping a regular stock all the year. The pastures are considered too valuable to be applied to the rearing of stock. Drying is not carried to any extent, and the butter made here is said to be held in little estimation. In some instances, where farms are let out for the dairy, the landlord supplies a succession of cows in milk, horses, and land, and the tenant furnishes labor, utensils, &c. paying at the rate of from six pounds to seven pounds ten shillings per annum, for each cow. The English long horned cattle were introduced many years ago into this district, which now contains some of the best specimens of the breed. The sheep are brought from other counties, and, like the cattle, the same stock is kept only for a season.

Tillage farms are larger here than in most parts of Ireland; but according to Curwen, the system of management is little better than on the small farms of other districts. The houses and fences are for the most part of the worst description, es-

**7085. WESTMEATH.** 578,880 acres of surface. with woods, lakes, streams, bogs, and rich grazing undulating or rising into hills of no great elevation; others covered with wood, presenting, in several parts, *Statistical Survey of Ireland. Sup. Encyc. Brit.*

The principal river is the Shannon, and the lake Lough Ree, full of wooded islands.

There are few large estates, but many gentlemen of moderate fortunes, from 2000*l.* to 5000*l.* a year, most of whom are resident. The leases are commonly for twenty-one years and a life, though in some instances for thirty-one years and three lives. A great many fine long-horned cattle, and long-wooled

**7086. LONGFORD.** 234,240 acres, in great part bog, mountains, and waste; the climate on an average giving 140 dry days in the year. (*Wakefield, &c. Sup. Encyc. Brit.*)

Landed property is in estates from 3000*l.* to 7000*l.* a year. Leases are commonly for twenty-one years and a life. Farms are, for the most part, very small, where tillage is the principal object; but only a small proportion of the district is under the

**7087. LOUTH.** 210,560 acres, mountainous towards the north, but in other parts undulating and fertile, with little waste land, no considerable lakes, and a great number of gentlemen's seats, of which that of Foster, a distinguished patriot, is the chief. (*Wakefield.*)

Landed property is in estates from 1500*l.* to 2000*l.* per annum. Farms are, in general, larger than in most other parts of Ireland; but there are still many very small; in some parishes, scarcely one above twenty-five acres, and in others they seldom extend to eighty acres. As the land is chiefly occupied in tillage, little attention is paid to the improvement of cattle and sheep; of the latter, though a few are kept on most farms, the number is inconsiderable. Wheat and oats are the principal corn crops, barley being very little cultivated. The other crops are potatoes, flax, and a little hemp. Clover and turnips are almost confined to the farms of proprietors. It is only on these that the general management is good; that of the common farmers being, for the most part, slovenly; and their lands requiring heavy dressings of lime and marl to keep them

**7088. WATERFORD.** 454,400 acres, the greater part hilly and mountainous, but rich and productive on the south-east; the climate so mild, that cattle sometimes graze all the year round. (*Wakefield, Curwen, &c. Sup. Encyc. Brit.*)

Some very large estates, of which the most extensive belongs to the Duke of Devonshire. Leases are commonly for twenty-one years and a life; and on the banks of the rivers, where the land is most valuable, farms are small. According to Wakefield's information, "in this county, when the eldest daughter of a farmer marries, the father, instead of giving her a portion, divides his farm between himself and his son-in-law; the next daughter gets one-half of the remainder, and this division and subdivision continues as long as there are daughters to be disposed of. In regard to male children, they are turned out into the world, and left to shift for themselves the best way they can." The rent is chiefly paid from the produce of the dairy, which is conducted on a greater or smaller scale over all the county, and from the plgs, which are partly fed upon its offals. Some of the dairy farmers, most of whom are in easy circumstances, pay 1000*l.* a year of rent; and a great deal of butter is

**7089. CORK.** 698,882 acres, of greatly varied surface; bold, rocky, and mountainous on the west, rich and fertile on the south and east, romantic and sublime in many places, and one-fourth part waste. (*Wakefield. Townscnd's Survey of Cork, 1810. Sup. Encyc. Brit.*)

The climate is mild, but a very general opinion exists that it is changing for the worse.

The rivers of this county flow with rapidity for the most part; a circumstance unfavorable to their being rendered navigable, but presenting many eligible situations for the erection of machinery.

The most useful fossils are limestone, marble, and slate; coal and ironstone have been discovered, but not worked to any extent.

Estates are generally large; tillage farms are very small, seldom above thirty acres; and, when they are larger, often held in partnership, and the shares of each further diminished by the common practice of dividing the paternal possessions among the sons. The leases used to be for thirty-one years, or three lives; but of late the term has been reduced to twenty-one years, or one life; and the farms, instead of being let out to middlemen, who used to relet the land in small portions to occupiers on short leases or at will, are now held in most cases by the occupier from the proprietor himself. There is here the usual minute division of tillage lands, cultivated by the spade in preference to the plough; the usual dependence on potatoes, as the common and almost exclusive article of food; with miserable cabins, crowded with filth, poverty, and indolence. The crops are potatoes, in favorable situations succeeded by wheat,

especially the cabins of the farm laborers, which are miserable mud-walled hovels, sunk below the level of the ground adjoining, and occupied by cows and pigs, in common with the family. The principal food of this class is potatoes with churn-milk, and occasionally oat-meal; butcher-meat being rarely used even among the farmers; and, to add to their privations, fuel is very scarce in different parts of the county. An uninterrupted succession of oats and other corn crops for several years is common; in a few instances even for twenty years. The common rotation is wheat, oats, fallow, potatoes, clover, all without the application of manure. It is customary to yoke horses intermixed with oxen, of which six are generally yoked together, three pair deep, to a very ill-constructed plough; yet, notwithstanding this management, the wheat crops are in some parts excellent.

Manufactures do not afford employment to any considerable part of the population, though here, as in most parts of Ireland, that of linen is carried on to some extent; and also the weaving of cotton. On the Blackwater and the Boyne there are several extensive flour mills.

The surface of this district is exceedingly diversified lands; in no parts mountainous or flat, but gently undulating or rising into hills of no great elevation; some of these are cultivated to their summits, and some of the finest scenery in Ireland. (*Wakefield's*

sheep occupy the grazing grounds, which extend over much of the best part of the district. Tillage is accordingly upon a limited scale, though more corn is raised than the inhabitants consume; and besides the crops common in other places, flax, hemp, and rape, are cultivated, with clover and turnips; the two latter, however, not generally.

Few or no manufactures.

plough. It is chiefly occupied in grazing, in which the resident gentry almost exclusively employ the farms which they retain in their own hands. Some linen manufactures.

productive. Yet, many of the tenants are in easy circumstances, well clothed, use meat in their families, and in every thing but their houses and farm buildings, are in a condition superior to that of their brethren in most other parts of Ireland. It is common to renew the leases some time before the old ones expire, so that the tenants are not often changed; but fines are frequently paid on these renewals, which carry away much of the capital that should be applied to the soil. Tithes are very seldom taken in kind; their value is ascertained about the end of harvest, and the tenants grant their notes for the amount, which, though payable in November, is in some cases not exacted till almost twelve months after. The linen manufacture is carried on to a considerable extent.

made, even among the mountains, where small cows, suited to the nature of the pastures, form the principal stock. In the neighborhood of Waterford, cows were let for sixteen pounds, eighteen pounds, and even twenty pounds for the season. There are very few sheep, and those of a bad description; and, comparatively, but a small portion is in tillage. Where lime is used as a manure, it must be brought from a distance, as there is no limestone to the east of Blackwater, and it costs upwards of five pounds for an acre. Orchards are numerous on the banks of this river, and extensive plantations of timber trees have been formed in various parts. Turf is so much used as fuel, that whole fields are kept under this shrub for the purpose.

Hogs are an important branch of trade at Milford Haven; glass and salt the principal manufactures.

and oats, for one or more years; sometimes barley follows the wheat. Flax is cultivated in many small patches. Hemp very rarely. Turnips and clover are seldom to be seen on tenanted lands. Sea-sand, sea-weed, and lime, form a useful addition to the stable and farm-yard manure; which is, however, in many cases, allowed to be washed away by the rains, and greatly reduced in value by management. Faring and burning of butter and skimmed milk, finds a ready market. In general the cows, which are chiefly of the half-Holderness breed, are let out to a dairyman, at a certain rate for each, by the year; yet, many farmers conduct the business of the dairy themselves. The average number of cows in a dairy may be from thirty to forty. A few sheep are kept on every farm, commonly in feters, and upon the most worthless pastures. Proprietors have introduced stranger breeds, and find them to answer; but sheep can never become an object of importance in a district where farms are so small.

Tithes, of which no inconsiderable part are lay property, are generally paid by a composition with the farmers. The usual mode is to have them valued before harvest, and to appoint days of meeting with the parishioners, for the purpose of letting them.

7090. TIPPERARY. 1,018,240 acres, diversified with heaths, mountains, and fertile vales; of which the Golden Vale is among the richest land in the kingdom. The climate so mild, that cattle graze out all the year. (*Wakefield, &c. Sup. Encyc. Brit.*)

*Minerals.* Slate, lead, and coal are worked.

*Estates* are of various sizes, some of them very large, but a greater number of a medium extent, worth from 4000l. to 6000l. a year. Of the proprietors, the influence of Lord Landaff is by far the most considerable, though several others have estates worth from 10,000l. to 15,000l. a year and upwards. The graziers here, as in Roscommon, have leasehold properties, frequently of much greater value than the freeholds, of which, also, they often become the purchasers. Properties of this description, worth from 2000l. to 4000l. a year, are very common.

Tillage farms, however, are generally of small extent, one of ninety Irish acres being thought large; yet the management is, in many instances, more respectable than in most other

7091. LIMERICK. 683,800 acres, of low laying fertile lands, surrounded by higher grounds. (*Wakefield, &c. Sup. Encyc. Brit.*)

*Landed property* is in large masses, generally let to tacksmen, on long leases, and sub-let almost *ad infinitum*. The land seems to be of greater yearly value than in most parts of Britain at a distance from large towns; for, according to Wakefield's information, the green acres would have let, in 1808, for three guineas the Irish acre, or almost forty shillings the English. Considerable farms brought five guineas the Irish acre, and in some instances more. The rent of the mountain land had increased in a still greater proportion than the grazing and corn farms. One grazier held land of the value of 10,000l. a year, and in one season slaughtered in Cork, 800 head of cattle. Many of the best long-horned cattle of the United Kingdom are fattened here, and also a considerable number of sheep.

7092. CLARE. 771,365 acres, nearly half productive land, and the remainder moors, mountains, and bogs, with more than 100 lakes interspersed. The climate, though moist, is not unfavorable to health and longevity; fevers, which sometimes prevail to a great extent here, being occasioned chiefly by the dampness of the houses, and inattention to domestic and personal cleanliness. (*Dutton's Survey of Clare, 1808. Sup. Encyc. Brit.*)

Limestone abounds, and coal, ironstone, black marble, lead, &c. have been found, but not worked.

*Landed property* is in a few large estates, of which the most noted was that belonging to the Marquess of Thomond's heirs, lately sold and divided.

The size of farms varies greatly. Those under tillage are from one or two acres to fifty, but of the latter size there are few. Grazing farms extend from 100 to 800 acres, several of which, and sometimes in distant situations, are held by one individual. Frequently several persons join in the occupation of an arable farm, and almost ten acres each. The general terms of leases, from proprietors, is for three lives or thirty-one years; sometimes, but not often, for three lives and thirty-one years; twenty-one years or one life, and twenty-one years and a life. The tenure of under tenants is variable, and often arbitrary.

All the different species of grain are cultivated with considerable success. Rye and flax, the former chiefly for its seed, and the latter for home manufacture, are sown to a moderate extent. Potatoes occupy a part of every farm, and their culture is conducted with more care and judgment than that of any other crop, though at a greater expense of time and labor than would be thought necessary in most other places. In regard to the kinds of crops cultivated, the greatest defect is in what are called green crops, corn being, with potatoes, the chief and almost the only objects of attention to the arable farmer; and turnips and cultivated herbage being either grown on a very small scale, or, as is the case throughout the greater part of the county, altogether disregarded or unknown. The corn crops thus necessarily follow each other, until the soil is exhausted; and where extra manure, such as sea-weed and seaweed, both of which are used as manure with good effect, cannot be procured, some is left in an unproductive state for several years afterwards. Potatoes are in most cases planted upon land that has been prepared by burning, and the same crop is sometimes taken for two years more without manure; in the fourth year wheat follows, and then repeated crops of oats, as long as they will replace the cost of seed and labor.

The implements in common use are generally rudely con-

7093. KERRY. 1,128,320 acres, more than three-fifths mountainous and waste; the sea-coast and islands being the most westerly land in Europe. Some of the mountains 3000 feet high. (*Smith's History of Kerry. Wakefield. Sup. Encyc. Brit., &c.*)

The mountains are chiefly occupied with young cattle and goats; sheep, apparently the most profitable animal in such situations, are neither numerous nor of a valuable kind; and the little cultivation to be found here is so generally performed with the spade, that, in some entire parishes, as Young assures us, there was not a single plough.

The prevailing soil in the low grounds is clay, of different qualities; some of it seems to be a species of pipe clay, and other sorts might be converted into bricks and earthenware.

*Estates* are very large, both in extent and value, some of them, according to Wakefield, worth 50,000l. a year. Leases are in general for thirty-one years and three lives, and a considerable portion of the whole county is let to partnership tenants. Few of the tenants in the north quarter about Kerry-head oc-

The principal manufactures are sail-cloth, duck, canvass and drilling; osanburgs for negro clothing; coarse woollens; spirits at several large distilleries in Cork; and gunpowder in the neighborhood of the same city, the only manufactory of that article in Ireland; it belongs to Government.

parts of Ireland. But the principal business is grazing, every variety of this kind of land being found here. Leases are commonly for twenty-one years and a life. The cattle, which are long-horned, may be ranked with the best in Ireland, and many of the fine flocks of long-wooled sheep are not inferior, in Wakefield's opinion, to those of Leicestershire. The rich lands produce a kind of flax, very different from that which is raised in the north; it grows to a great height, and appears to be exceedingly well adapted for sail-cloth.

The manufacture of broad-cloth is carried on to some extent at Cork; and that of wens, worseds, and coarse woollens, as branches of domestic industry. But the wealth of this extensive district chiefly consists in its cattle and sheep, corn, and other land produce.

Two year old wethers sold then, without their fleece, at from 2l. 10s. to 5s.

Only a small proportion of the land is in tillage; the produce of this, and some of the adjacent counties, in proportion to the seed, is stated by the same author to be at a medium: of wheat ten, bar seven, barley twelve, oats nine, and potatoes ten. Hemp was formerly cultivated extensively on the rich low grounds, called the Carcasses, on the banks of the Shannon, but this tract is now occupied in grazing. Flax of an excellent quality for sail-cloth, is still grown in several parts. The common term of leases is thirty-one years and three lives. Great part of the provision and corn trade is possessed by the city of Limerick.

structured, and imperfect as well as expensive in their operation; in many parts, even where the soil is light and dry, the plough is drawn by four horses abreast, with traces of rope and collar of straw. But from the roughness of the surface, the poverty of the tenantry, and the minute division of farm lands, the spade is much more extensively employed than the plough, over all the arable land of this county.

The pastures of the Carcasses or low grounds, on the rivers Shannon and Fergus, are equal to the fattening of the largest oxen. This rich tract extends from Paradise to Limerick, about twenty miles, and is computed to contain about 20,000 acres, of a deep, dark colored soil, over a bluish or black clay, or moory substratum; producing, owing to the boldness of its occupiers, along with the most valuable herbage, a great quantity of rushes and other useless weeds. The rent of this land for grazing, was several years ago as high as 5l. per acre, equal to about 3s. 2s. per English acre, and for meadow, in many instances much more. The mares are said to produce at the rate of more than four tons of hay the English acre. The cattle of this county are almost all long-horned, good milkers, and very hardy. The sheep have been greatly improved in shape, by crosses with Leicester rams, but there is a general complaint that the quality of the native wool has been deteriorated. A vast number of mules are bred here; asses are very generally employed by the poorer classes; but little attention is paid to the breed of horses, which has degenerated.

Clare was formerly noted for its orchards, and for cider of a very fine quality, made from the celebrated cackage apple, which is still found near the small town called Six Mile Cross. "An acre of trees," says Young, "yields from four to ten hogsheads per annum, average six; and, what is very uncommon in the cider counties of England, yield a crop every year." It does not appear from the latest accounts, that any considerable quantity of this cider is now produced here, though what there is, seems to maintain its former character, and is held in great estimation.

*Manufactures* are yet in their infancy. All the linen made in the county is used for home consumption.

copy so much land as to require them to employ laborers; they pay their rents by the sale of butter and pigs, and by turf which they carry to Limerick. It is the practice for farmers to hire large tracts, which they stock with cows, and these cows are then let out to dairymen upon such terms as leave them but a very small return for their labor. The best corn land is about Tralee, and towards Dingle, where more flax is raised than in any other part of the county.

The principal articles which Kerry affords for export are its raw produce, beef, butter, hides, and tallow. It does not raise more corn than is necessary for its home consumption, and carries on no manufacture for sale, but that of coarse linen, which is only on a small scale.

**7094. ROSCOMMON.** 556,847 acres of flat surface, in some places sprinkled with rocks, and, in many, interrupted by extensive bogs; the richest land on limestone, and adapted either for aration or pasture. (*Wakefield. Sup. Encyc. Brit.*)

Coal and iron works were formerly carried on, but are now neglected.

*Estates* were once very large; but they have been broken down in some instances, by the granting of leases in perpetuity; a practice which has given rise to a class of landholders, interposed between a few great proprietors on the one hand, and a numerous body of cultivators on the other.

Some of the best long-horned cattle and long-wooled sheep in Ireland fed, but there are few dairies. During the late war, its fine green pastures, under this management, afforded a very ample rent, and tillage was therefore conducted on a small

**7095. GALWAY.** 1,659,520 acres of varied surface; above a third part bogs, mountains, and lakes, and very unproductive and thinly inhabited. (*Dutton's Survey of Galway, 1824. Wakefield. Sup. Encyc. Brit., &c.*)

The east part of the county is flat, warm, and fertile; with many seats, though none of note. Rivers and lakes abound. Lough Reagh and Lough Coutra are fine pieces of water; the latter is said to possess all the beauties that hills, woods, and islands, can impart to that feature of landscape.

Several large estates, affording an income of from 5000L to 10,000L a year, and upwards. One of these, the most extensive in the British Isles, stretches along the sea-coast for seventy miles. Only a small portion is held by absentees. A full third of the land is let on partnership leases, to an indefinite number of persons, very often twenty, who by law are joint tenants, and entitled to the benefit of survivorship. The leases are commonly for three lives, or thirty-one years. "These people," says Wakefield, "divide and give portions to their children, which consist of a fourth or a fifth of what they call 'a man's share,' that is, of the land which originally belonged to one name in the lease. A certain portion of the whole farm, or take, as it is styled, is appropriated for tillage, and this portion is then divided into lots, perhaps twenty or thirty. These lots are again subdivided into fields, which are partitioned into small lots, each partner obtaining one or two ridges; but these ridges do not continue in the hands of the

**7096. MAYO.** 1,496,460 acres, in great part mountains, with valleys very fertile, but neither woods nor plantations, *excepting on one or two estates.* (*M<sup>r</sup>Parlan's Survey of Mayo, 1802. Wakefield. Sup. Encyc. Brit.*)

Many valuable fossils: iron formerly made, but discontinued for want of fuel. Excellent slate; and petroselinus semilucidus similar to what is used in the English poteries.

The *estates* worth from 7000L to 20,000L a year; but their extent, owing to their containing a great proportion of waste land, is still greater than in the ratio of their value.

The size of farms varies with the nature of the soil and surface, but, though several hundred acres are sometimes let out in one farm, yet, as the farms are commonly held in partnership, the space allotted to each tenant is generally only a few acres. As each of them keeps a horse, it is computed that there is one for every ten or twelve Irish acres. The leases are for different periods, fifteen years, twenty-one years, and one, two, and sometimes three lives, or thirty-one years.

*Agriculture* is in a very backward state. The plough commonly drawn by four horses abreast, is of the worst description, and the harrows are often furnished with tines of wood, instead

**7097. LEITRIM.** 386,560 acres, one half bog, waste, and water, and the remainder dark fertile soil, incumbent on limestone. (*M<sup>r</sup>Parlan's Survey of Leitrim, 1802. Wakefield. Sup. Encyc. Brit.*)

Coal, ironstone, lead, copper, &c. are found, but not worked.

*Estates* large, and nearly all the great proprietors are absentees. The leases are commonly for three lives, or thirty-one years. Agriculture is here in a very low state. The tillage farms are small, seldom exceeding fifty or sixty acres, and these are almost always subdivided among a number of tenants. The plough is very little used. The most common implement is the

loy, a kind of spade eighteen inches long, about four inches broad at the bottom, and nearly five or six inches at the top, where it is furnished with a wooden handle about five feet long. The first two crops are potatoes, which are followed by flax, and then oats for one or more years. Clovers and other green crops are unknown in the practice of the tenantry. The county raises grain and potatoes sufficient for its own consumption, but exports very little of either. Its cattle have been much improved by the introduction of English breeds, to which division of those now bred and reared in it are said to be not inferior. There are no considerable dairies, yet a good deal of

**7098. SLIGO.** 465,280 acres, a third part bogs, mountains, and waters, and the remainder fit for tillage or grazing. (*M<sup>r</sup>Parlan's Survey of Sligo, 1802. Wakefield. Sup. Encyc. Brit.*)

The subsoil of a considerable tract a grey flag, provincially leached, unfavorable to vegetation. Numerous streams and lakes; the wooded islands and scenery around Lough Gill, very striking. On the Sligo and Moy, considerable salmon fisheries; trouts abound, and white fish on the shores.

*Estates* of almost every size. A few are worth from 500L to 9000L a year; yet, a considerable proportion of the county is divided into small properties. The principal proprietors are absentees. Farms vary in size, from three Irish acres to 500; the larger farms, however, are not held by individual tenants, but in partnership. The leases are for thirty-one years and three lives; and, in some instances, for sixty-one years and three lives, being, in general, longer here than in other parts of Ireland. Tillage-farming is still in a very backward state. The plough is worked by three or four horses yoked abreast, directed by a man who walks backwards before them. Oats,

scale; but the plough has been more in request since the peace, both here and in other parts of Ireland; and the soil of such rich grazing lands, requiring nothing more than the common operations of tillage to yield large crops, the growth of corn throughout Ireland has been greatly increased; yet, within these few years, agriculture was here in a very backward state. "In Roscommon," says Wakefield, "I heard of horses being yoked to the plough by the tail, but I had not an opportunity of seeing this curious practice. I was, however, assured by Dean French, that it is still common with two year-old colts in the spring." Potatoes, oats, and flax, are the principal crops.

same occupier longer than the time they are in tillage. The pasture is held in common; and the elders of the village are the legislators, who establish such regulations as may be judged proper for their community, and settle all disputes that arise among them. Their houses stand close to each other, and form what is here called a village.

The *cattle* of Galway are long-horned, and of an excellent description, fully equal, in the opinion of Wakefield, to any in England. But sheep form the most valuable part of their live stock; "some of the first flocks in the world," says the same writer, "are to be found in this county." The crops are the same as in other parts of Ireland, but potatoes are not cultivated to so great an extent. They plant potatoes on an oat stubble, or on ley that has been burned or manured, and follow with wheat, bear or barley, or oats; the latter kind of grain is not infrequently taken after wheat and barley. Faring and burning the soil is very common. The greater part of the rent of some of the estates on the shore is paid from kelp, which is prepared in large quantities.

In common with the greater part of Ireland, Galway employs some of its people in the linen manufacture, and it seems to be the only manufacture in it worth notice.

of iron. It is still the practice, in the mountain district, to yoke the horses by the tail. But, in some of the baronies, the plough is seldom or never employed at all, the tillage being performed by the spade; and in others they use the spade in cultivating potatoes, and the plough only for corn. Yet potatoes, oats, and, on the sea coast, barley, are sown to a considerable extent, and also flax. Wheat is cultivated only in particular spots, and chiefly by proprietors, a few of whom have also introduced turnips, peas, beans, rape, and cabbage. There is some excellent grazing land for cattle in the barony of Tyraveil, and good sheep pastures in Kilmain. Some graziers hold 3000 Irish acres. The English long-horned cattle, which were imported by the principal proprietors, have greatly improved the native breed.

The habitations of the laborers, or cottars, are in general very wretched, and shared by them with their cow and pig.

butter is made throughout the district. The sheep are of the native race, small, and but few in number.

About the beginning of the eighteenth century, Leitrim is said to have been almost a continued forest. There is now little wood in it, and no considerable plantations. The proprietors, however, have of late paid some attention to this method of improvement, and several large nurseries have been established for the sale of forest and other trees.

There are several bleachfields, and some coarse potteries; and a number of people are employed in weaving. But the linen made here, as well as the coarse woollen goods, is chiefly for the use of the inhabitants themselves. The houses of the lower classes are of the worst description; even the more recently erected farm buildings, including a little barr and cow-house, do not cost more than ten or twelve pounds. Turf is their only fuel, and potatoes and oatmeal bread the chief articles of food, meat being used on extraordinary occasions only.

barley, and potatoes, are the principal crops. Of the former, a great proportion is consumed in illicit distillation, which, within these few years, was carried on in almost every part of the county. It was to the sale of the spirits that many of the small tenants looked as the means of paying their rents. In some parts, both cattle and sheep are kept in considerable numbers, and a great deal of butter is exported from the town of Sligo; but the land occupied in this way bears but a small proportion to the whole; to grow corn being the principal object. Limestone and limestone-gravel, which are in abundance in most places, are in general used as manures; also marl, and, on the coast, sea-weeds.

The *manufactures* for export are linen, salt, and kelp. The cabins, food, fuel, and clothing of the lower classes, seem to be as uncomfortable as in any of the Irish counties.

7099. CAVAN. 499,957 acres, almost entirely covered with hills; the surface, soil, and climate, being alike bleak and uncomfortable. (*Coote's Statistical Account. Wakefield. Sup. Encyc. Brit.*)

Near Farnham, the appearance of the country is favorable; the lakes there are picturesque, and communicate with each other by a river. The fossils are various, but neglected.

Two estates are of 30,000 and 26,000 acres, besides these there are none of very great extent. Nearly the whole of the land is under tillage, but the agriculture in every respect is very bad. The size of the farms is from 50 to 100 acres, but these are generally subdivided into farms of from two to twenty acres, which are re-let to the manufacturers or "cottagers," who pay a high rent for them, by means of their other employments. Their principal object is to raise a sufficient quantity of oats and potatoes to feed their families, and of flax to give employment to the women and children. Most of the land is dug with the spade, and trenched; where the plough is used, they put three or four horses to it; and when Young visited the county, he found that all over it, the horses were yoked to the ploughs and harrows by the tail; that practice, however, is now disused. Almost the only grain sown is oats, which are reckoned to be in the proportion of seventy to one, to all other grain; there is scarcely any wheat. In 1809, there were 4500 acres of flax, from which 6500 bushels of seed were saved.

7100. FERMANAGH. 450,000 acres, in great part covered by water, and much of the rest of the surface rugged and mountainous, but better wooded than other parts of Ireland. (*Wakefield. Sup. Encyc. Brit.*)

The ash grows in the hedgerows; beeches come to a large size, and also the yew, near Lough Erne; and fir, oak, and yew, are found in the bogs. The grand feature in the natural scenery of this county is Lough Erne, which occupies about one-eighth of the surface, and contains more than three hundred islands. It contains most of the fish that are found in other fresh water lakes, and is noted for its salmon and eels, particularly the latter. Four of the eel weirs near the falls of Beelock, afford a rent of 100*l.* each.

Estates are large, three proprietors mentioned in Wakefield, have 15,000*l.* a year each, and other three from 6000*l.* to 7000*l.* The leases are most commonly for twenty-one years and a life.

7101. MONAGHAN. 325,760 acres of low grounds, with detached hills, and a considerable space occupied by bogs and small lakes. (*Coote's Survey of Monaghan, 1801. Wakefield. Sup. Encyc. Brit.*)

There are a few large estates, but the greater part small ones, many of which do not yield a free income equal to the ordinary wages of labor. A few years ago, there were only 172 freeholders of 50*l.* and upwards, out of nearly 6000, most of the considerable proprietors are absentees, and very little of the landed property is in the hands of Catholics.

Farms were so small a few years ago, as not to average ten Irish acres over the whole county; and the management, as might be expected, was exceedingly unskilful and unproductive. The spade was used much more than the plough; the latter being an implement which, with the team required to work it, and the party to attend and direct it, could be brought into action only by the united efforts of several tenants. The

7102. TYRONE. 813,440 acres in great part mountainous, and containing, among other mountains, Bessy Bell and Mary Gray, celebrated in song. The territorial value of this inland and northern district is much inferior to that of most others. (*M'Evoy's Survey of Tyrone, 1802. Sup. Encyc. Brit.*)

Various valuable fossils found, but not worked; the best pottery in Ireland, near Dungannon. Lough Neagh, the largest lake in Ireland, covers 110,000 acres, but is not celebrated for its scenery.

Estates are of very great extent, many of them worth from 5000*l.* to 7000*l.* a year, and the productive or arable land divided into very small farms, not often exceeding twenty Irish acres. The chief proprietors are the Marquess of Abercorn, Lords Belmore, Northland, and Mountjoy. The leases are for various periods, thirty-one years and three lives, three lives, and twenty-one years and a life. On some estates the land passes through the hands of middlemen, in portions of various sizes, till it reaches the actual cultivator, for the most part, in very minute subdivisions. It is customary for several persons to be concerned in one township, which is held in what is called rundale, the cultivated land being divided into shares, which are changed every year, and the cattle pasturing in common, a system utterly inconsistent with profitable occupation, or the amelioration of the soil and live stock. The cattle and

7103. DONEGAL. 1,100,000 acres of ragged, boggy, and mountainous surface, with a cold, wet climate, and neither woods nor plantations to shelter from the blast. (*M'Parlan's Survey of Donegal, 1802.*)

Landed property is in few hands.

Agriculture is in a very backward state in Donegal. The use of the plough is confined to a small proportion of the cultivated land, and is generally of a bad construction; spade labor is preferred in most places. Barley is the chief grain crop, and it is almost all used in distillation; oats are only grown for home consumption, and wheat is confined to a few favorite spots. There are only two flour mills in the county. The culture of flax is considerable in the barony of Raphoe, and is extending even in the mountain districts. Potatoes are cultivated every where; turnips, clovers, and other green crops, are almost unknown among the tenants. Villages or parishes are still abundant, but farms now begin to be let to individuals as separate holdings. In the low country they are from ten to fifty acres in extent, and from 40 to 500 in the mountains. The fences are commonly nothing better than ditches, with banks of turf or clay, so that the cattle require to be herded while the crops

are growing, and in many parts they are allowed to graze promiscuously as soon as the crops are removed. Sea-weed and shell-sand are used as manures, but very little limestone, or limestone gravel. The practice of paring and burning, so common in many parts of Ireland, is seldom resorted to in this county. Leases are granted for twenty-one years and a life.

The staple manufacture of Donegal is linen. Women are much employed in knitting stockings. Kelp is prepared along the north-west coast; and, during the fishing season, three or four salt-pans used to be kept in full working. But by skipping, says the M'Parlan, particularly in the mountain region, and all around the coast, is the chief manufacture. "It is by whisking their barley into this beverage that they provide for one half-year's rent. This is, therefore, a tax raised by the rich on the morals and industry of the poor."

Though the very tops of the hills are tiled, yet it does not appear that this county produces more grain than is necessary for its home consumption; nor has the bounty on the inland carriage of corn to Dublin, increased the very trifling quantity brought to that market. From the coldness and moisture of the climate, all the corn of Cavan is obliged to be kiln dried.

The stock farms generally consist of about 100 or 150 acres, the farmers buy young cattle, and sell them again without fattening; a few, however, fat bullocks or sheep, but the latter are very poor. There are very few dairy farms, though from these, as they are in the richest parts of the county, a good deal of butter is sent. Many pigs are kept by the cottagers, and near all the cabins are to be seen goats tethered to the tops of the banks, or "ditches," as they are here called, which divide the fields.

Cavan was formerly celebrated for its extensive woods, and trees of an immense size; but at present it is, in general, bare of timber, except near Kilmore, Farnham, and a few other places, Wakefield remarks, that the ash is confined to parts of this county, and to Tyrone and Fermanagh.

The linen manufacture is the staple.

In the northern part of the county, the farms are larger and more productive than in most other parts of Ulster. Oats, barley, potatoes, and flax, are the principal crops; very little wheat, clover, or turnips being cultivated, except in small patches near the towns. The high grounds are chiefly occupied in rearing cattle, and much of the better pastures with dairy stock. There are no large flocks of sheep, and their breed of this animal is of a very inferior description.

Linen seven-eighths white, is manufactured to some extent, and there are several bleach-fields, which finish for sale the linens sent to England. Illicit distillation is said to be very general.

general term of leases is twenty-one years, and a life, or sometimes three lives. The principal crops are oats, potatoes, and flax, with wheat and barley in a small proportion; these last, however, extend over a much greater tract now than they did a few years ago. They make a good deal of butter, but there are no large dairies. Goats are in greater numbers than sheep, which is in itself a sufficient proof of the low state of its agriculture.

The linen manufacture is said to have averaged twenty years ago, about 300,000*l.* a year. It is carried on by the greater portion of the inhabitants of both sexes, all the small farmers being also weavers.

sheep are accordingly of a very inferior description; and the litter, which are not numerous, may frequently be seen tethered upon the small patches of herbage which are interspersed among the shares of these partnership concerns. The tillage land, too, is more frequently stirred with the spade than the plough; and where a plough is used, the team, consisting of horses, bullocks, and even milch cows, must be supplied by the contributions of three or four neighbors, who unite their means for the purpose, each attending the operation, lest his poor animal should have more than his proper share of the labor. Potatoes, oats, and flax, are the principal crops.

The linen manufacture is carried on to a great extent, and the potteries and collieries employ a considerable number of hands; to which we may add illicit distillation, which prevails throughout all the north-western counties of Ireland. The food of the lower classes is oat-meal and potatoes; wheaten bread and butcher meat never being used but on extraordinary occasions.

7104. LONDONDERRY. 510,720 acres, generally mountainous, fertile and beautiful in the vallies, and containing every variety of soil. (*Sampson's Survey of Londonderry, 1802. Wakefield. Sup. Encyc. Brit.*)

*Landed property.* With the exception of lands belonging to the church, and the towns of Londonderry and Coleraine, and certain portions reserved by the Crown to be afterwards erected into freeholds, the whole of Londonderry was granted by James I. to the twelve companies or guilds of London. The estates are therefore held from these companies, either in perpetuity, or on determinable leases. The principal proprietors or leaseholders are Lords Waterford and Londonderry, Conolly, Ogilby, and the families of Beresford and Ponsonby.

The average size of farms is from five to twenty Irish acres, or at a medium little more than fifteen acres English. Whole districts are sub-divided into patches of seven or eight acres, but in a few situations there are farms of upwards of 300 acres.

7105. ARMAGH. 290,786 acres of varied and rather interesting surface of mountain, plain, and bog; with rivers, streams, and lakes, and a climate mild for the latitude. (*Coote's Survey of Armagh, 1804. Wakefield. Sup. Encyc. Brit.*)

*Marble* of an excellent quality, and of great beauty, is wrought in Armagh.

*Estates* in this county are not large, there being only seven or eight proprietors who possess them of the annual value of from 6000*l.* to 10,000*l.* The farms also are small, being commonly from five to twenty acres, and seldom exceeding forty or fifty.

Neither the arable nor the pasture husbandry in this county present much that is worthy of notice. Potatoes, flax, and oats, are the chief produce of the arable districts; and those are cultivated in a very rude and inferior manner, in consequence of the ignorance of the farmers, and their want of capital.

There are no extensive dairy farms, nor are there any farmers exclusively in this branch of husbandry; nevertheless a considerable quantity of butter is made here. One hundred weight per cow is considered as the average produce. The proportion

7106. DOWN. 538,289 acres, of which one-eighth are mountainous and waste, the remainder hilly and productive, cultivated by small manufacturers, and neat white-washed habitations. The climate is variable, but not subject to extremes. (*Dubourdieur's Survey of Down, 1802. Sup. Encyc. Brit.*)

*Landed property.* There are some large estates, though in general it is much divided, and has all the different gradations, from the most opulent nobleman to the tenant in perpetuity who farms his own land. Most of it is freehold. The rental was above the average rental of the best counties in Scotland, as returned to the commissioners of the property-tax in 1811.

The farms may be divided into two kinds; the first, such as are possessed by farmers who have recourse to no other branch of industry; the second, such as are held by weavers and other tradesmen. The former run from twenty to fifty, and, in some instances, so far as 100 acres; the latter are of every size, from one to twenty acres. The rent is always paid in money; personal services are never exacted. Some leases are for lives and years, others for lives alone. Fences consist chiefly of a ditch and bank, without quicks of any kind, or sometimes with a few plants of furze stuck into the face of the bank; but dry-stone walls are frequent in the stony mountainous parts. Great improvement has been made in its agriculture within these twenty years. Threshing mills and two-horse ploughs have been introduced. But it cannot be said that a good system prevails generally, which the small size of the farms, indeed, render impracticable. A regular rotation is rarely followed in the crops; fallows, clovers, and turnips, are upon a very small scale; and from the greater part of the arable land, it is still the practice to take crops of grain in succession, only partially interrupted by potatoes, flax, and peas. Oats, the principal

7107. ANTRIM. 622,059 acres; on the east and north mountainous, destitute of plantations, and abounding in bogs; the other parts more level and fruitful, and the climate drier than in some other counties. (*Newenham's Statistical Survey. Wakefield. Dubourdieur's Survey of Antrim, 1812. Sup. Encyc. Brit.*)

*Minerals.* Besides basalt, limestone, gypsum, coals, fossil-wood, or wood-coal, sandstone, &c. are found. The fossil-wood, or wood-coal, in most places, is covered with columns of basalt, and is curious as explanatory of the origin of coal. Notwithstanding the compressed state in which it is found, the bark and knots are quite distinct, and the rings denoting the annual growth of the wood may be counted. In some instances the roots of the trees may be traced. Of the only two coal mines which are wrought in the province of Ulster, there is one in Antrim, at Bally Castle. The coals are bituminous, and of a bad quality; a great part of them are exported.

*Landed property.* Estates are in general freehold, being either immediate grants from the Crown, or held under these grants. The exceptions are the properties under the see of Connor. Some of the estates are very large. The Marquess of Hertford, and the Antrim family, possess the fee of the major part of the county. The former has 64,000 *acres*; that is, land capable of tillage, and independently of bog and mountain. Most of the Antrim estate is let on perpetuity, in farms worth 2000*l.* or 3000*l.* per annum. The other great proprietors are the Marquess of Donegal, and the Templeton, however, is only leasehold under the Marquess of Donegal, who lets his land for sixty-one years and a life, but renews at the end of a few years for a price.

The farms are in general very small. The principal feature in the tillage system is the potatoe fallow. The small size of the farms, and, in some places, the rockiness of the soil, precludes

The leases are for a great many different periods, though most commonly for twenty-one years and one life.

The principal crops are potatoes, barley, oats, and flax. Wheat is not in general cultivation. Turnips are very common, and sown grasses and clovers far from being common. No uniform rotation of crops is recognised in practice, but it is usual to take two crops of oats successively, and sometimes flax the year following. Flax is the predominating plant in the meadows, where it grows spontaneously with great luxuriance. The live stock presents nothing worthy of particular notice. Grazing grounds are not extensive, and there are few dairies. On the east side of the Bawn there are two extensive rabbit-warrens.

The principal manufacture is linen; the value exceeds half a million sterling, besides brown or unbleached linens.

of the milch cows to the size of the farms is, on small farms under five acres, one cow; on farms exceeding five, and under ten acres, perhaps two cows, seldom more. A considerable number of cattle are reared. From the low country they are sent to the mountain farms, and frequently afterwards sold in the Scotch market. They are in general of a small stunted breed. The native sheep are an awkward breed; the wool coarse, and in small quantity; very little of it is exposed to sale, there being hardly sufficient for domestic use. Goats, swine, and poultry abound. Wild geese, swans, wild ducks, and several other species of aquatic birds, are indigenous to the lakes and rivers. Formerly bees were much attended to, but at present they are neglected.

The roads in general are bad; and, what is extraordinary, the turnpikes are the worst, and the cross roads the best. The principal manufacture is that of linen.

grain, are grown on all soils; barley is usually sown after potatoes, and also wheat to some extent on the coast. Of flax they sow four bushels an Irish acre, and the medium produce is fifty stanzas. Rye and peas occupy but a small space. Lime, marl, shelly-sand, and sea-weed, are used as manures. Faring and burning are confined to the mountains.

There are extensive meadows on the banks of the Bann and the Laggan; but the soil, except on the mountains, is thought to be better adapted to tillage than pasture. A good many beasts are fatted, but cows are the prevailing stock, kept in small numbers on every farm. They are long-horned, thin in the sides, and deep in the belly, but yield much milk when well fed, and each of them from 60 to as much as 150 pounds of butter in the year, or about two-thirds of the medium produce of the butter dairies of England. Sheep, in flocks of any size, are confined to the mountain districts. They are very small, many of them, when fat, not weighing more than seven or eight pounds a quarter. On the low ground there are a few, seldom exceeding half a score, on almost every farm. A great number of hogs are fattened; many of them bred in the county, but not a few brought from the west of Ireland. The dry hills of this county, covered with heath and odoriferous herbs, are well adapted to bees, but the number of hives has greatly decreased within these twenty years.

The principal manufacture is linen, which is carried on in all its branches.

the use of the ordinary means of culture, and therefore a part of the land is dug with the spade. The quantity of potatoe-land is regulated by the quantity of manure that can be collected. After potatoes, flax is sown, and the quantity of flax ground is regulated by the ability to purchase the seed. A crop of oats furnishes the regular rotation. When the ground is exhausted, it is turned to rest, that is, it is suffed to lie till it is covered with natural grass. Such is the most general plan of husbandry pursued in Antrim. In those parts where the farms are too large for the spade culture, the land is ploughed by three or four neighbors uniting their strength; one supplying the plough, and the others bringing a horse, bullock, or even a milch cow. Wheat is a plant of very modern introduction in Antrim, and very little of it is sown.

The most important crop is flax. The cattle consist chiefly of milch cows, belonging to small occupiers, of a small stunted breed. Sheep are very little attended to; and the few that are kept are of a very inferior kind. Goats are numerous in the mountainous parts of the county. Hogs also are kept in great numbers.

This county by no means abounds with wood; nor are fruit-trees cultivated in great abundance, or with very much success. Of the apple, however, several new and valuable varieties have lately been introduced, and advantageously cultivated.

Antrim has long been distinguished for its linen manufacture; but latterly the manufacture of cotton has, in some measure, supplanted it, especially in the vicinity of Belfast.

There is a considerable salmon-fishing on the coast.

## CHAP. IV.

*Of the Literature and Bibliography of Agriculture.*

7108. The first books on agriculture were written by the Greeks before the Christian æra, and by the Romans about the commencement of that period. Hesiod is the only writer of the former people exclusively devoted to husbandry: the earliest Roman author is Cato, and the latest, Palladius, in the fourth century A.D. The works of these and the other agricultural writers of antiquity have been already enumerated (18. and 44.), and the most interesting have lately been re-translated (7110. anno 1800).

7109. In the dark ages few books were written excepting on religion. The first author which appeared on the revival of the arts was Crescentius in Italy, in the fifteenth century; and soon after, in the sixteenth, Fitzherbert in England, Etienne and Liebault in France, Heresbach in Germany, and Herrera in Spain. Since these works appeared, many others have been published in every country in Europe, especially in England, France, and Germany. Though our business is chiefly with the works which have appeared in Britain, yet we shall, after enumerating the chief of them, notice also what has been done in other countries — many foreign works, especially of France, Germany, and Italy, being familiar, either in the original or by translations, to the reading agriculturists of this country.

SECT. I. *The Bibliography of British Agriculture.*

7110. A general view of the literature of British agriculture having been already given (781.), we have here only to supply the bibliographical enumeration confirmatory of that view. Of agricultural books very few at the present day are worth reading for their scientific information; they are chiefly to be considered as historical documents of the progress of opinions and practices; and this is the reason we have arranged them in the order of their appearance, instead of classing them according to the subjects treated of. Those who wish to see them so classed will be amply gratified by Watts's *Bibliographia Britannica*. In our list we have omitted many works on subjects belonging to political agriculture, as the corn laws, tithes, poor-rates, &c.; and also most of those on veterinary surgery, horsemanship, bees, hunting, planting, &c., as not strictly belonging to the subject, and as being for the greater part, those on the veterinary art in particular, worse than useless. In short, the improvements in chemistry, animal and vegetable physiology, and the comparatively clear views of political economy which have taken place chiefly since the commencement of the present century, have rendered most books on agriculture, whether political or professional, not published within the last ten years, of very little value, and a number of them more injurious than useful. In our list those authors who have merely written articles published in the transactions of societies, or in public journals or magazines, are seldom introduced, unless they have also written separate works, and translations are in general omitted.

1532. *Fitzherbert*, Sir *Anthony*, a very learned lawyer, and also known as the father of English husbandry, was born at Norbury, in Derbyshire, and died there in 1538. He was made judge of the Common Pleas in the 15th of Henry VIII., and wrote several books on law.

1. The Book of Husbandry, very profitable and necessary for all persons. Lond. 8vo.
2. Surveying; and Book of Husbandry. Lond. 1547. 8vo.
3. The Reading on the Statute 4 Edward I. De Extenta Maneril. Lond. 1539.

1535. *Benese*, Sir *Richard*, Canon of Martin Abbey, near London.

The Manner of Measuring all Manner of Land.

1557. *Tusser*, *Thomas*, styled the Christian Varro, was born near Witham, in Essex, 1515; received a liberal education at Eton School, and at Trinity Hall, Cambridge; lived many years as a farmer in Suffolk, and afterwards removed to London, and published his experience in agriculture and gardening. He died in 1580.

1. Five Hundred Points of good Husbandry. Lond. 4to.
2. Another edition entitled Five Hundred Points of Good Husbandry, suited to as many of Good Huswifery; with divers approved lessons concerning Hops and Gardening. Lond. 1575.

1581. *Mascall*, *Leonard*, author of a work on sowing, planting, and grafting trees, &c. 1572.

1. The Husbandly Ordering and Government of Poultry, &c. Lond. 8vo.
2. The First Book of Cattel, &c. Lond. 1596. 4to.
3. A Booke of Fishing with Hooke and Line, and all other instruments thereunto belonging: another of Sundrie Engines and Trappes to take Polcats, Buzards, Rats, Mice, and all other kindes of Vermin and Beastes whatsoever; moste profitable for all Warriners, and suche as delight in this kinde of sporte and pastime. Lond. 1600. 4to.

1593. *Markham*, *Gervase*, *Jarvis*, or *Gervase*. An

author, who wrote on a great variety of subjects during the reigns of James I. and Charles I., and died about 1685. He appears, says Harte, (*Essays*, ii. 32.) to be the first Englishman who deserves to be called a hackney writer.

1. The English Husbandman; 2 Parts. Lond. 1615. 4to.
2. The Country Farmer. Lond. 1616. fol.
3. Farewell to Husbandry. Lond. 1620. 4to.
4. Cheap and Good Husbandry, for the well ordering of all Beasts and Fowls, &c. Lond. 1651. 4to.
5. Enrichment of the Weald of Kent, &c. Lond. 1631. 4to.

1609. *Butler*, *Charles*, Vicar of Wotton, in Hampshire, an ingenious writer on various subjects, was born 1559; died 1647.

Feminine Monarchy; or, The History of Bees, and the due ordering of them. Oxon. 8vo.

1626. *Speed*, *Adam*.

1. Adam out of Eden; or, An Abstract of divers excellent Experiments, touching the Advancement of Agriculture. Lond. 12mo.
2. Husbandman, Farmer, and Grazier's Complete Instructor. Lond. 1697. 12mo.

1635. *Calthorpe*, *Charles*.

The Relation between a Lord of a Manor and the Copyholder, his Tenant. Lond. 4to.

1638. *Plattes*, *Gabriel*, author of some tracts on Gardening; a poor man but a useful writer. Harte says, he had a bold adventurous cast of mind, and preferred the faulty sublime to faulty mediocrity. As great a genius as he was, he was allowed to drop down dead in London streets with hunger; nor had he a shirt upon his back when he died. He bequeathed his papers to Hartlib, who seems to have published but few of them.

1. Treatise of Husbandry. Lond. 4to.
2. Discourse of Infinite Treasure, hidden since the World's beginning, in the Way of Husbandry.

3. Discoverie of Subterranean Treasure, viz. all manner of Mines and Minerals, from the Gold to the Coal, &c. with directions for the finding them. Lond. 1639. 4to.
4. *Recreatio Agricola*. Lond. 1640. 4to.
5. Observations and Improvements in Husbandry, with Twenty Experiments. Lond. 1655. 4to.
1642. *Vermueden*, Sir C. a native of Holland, and a colonel in Cromwell's army.
- Discourse touching the Dreyning the great Fens lying within the severall Countie of Lincolne, Northampton, Huntingdon, Norfolk, Suffolke, Cambridge, and the Isle of Ely. 4to.
1645. *Hartlib, Samuel*, an ingenious writer on agriculture, and author of several theological tracts. He was the son of a Polish merchant, and came to England, according to Weston, about 1640; but the time when he died is unknown. He was a great promoter of husbandry during the times of the commonwealth, and was much esteemed by all ingenious men in those days. Milton addressed to him his treatise on education, and Sir William Petty inscribed two letters to him on the same subject. Cromwell allowed him a pension of a hundred pounds a year.
1. Discourse of Husbandry used in Brabant and Flanders, shewing wonderful Improvements of Land there. Lond. 4to.
  2. *Legacy*; or, an Enlargement on the Discourse of Husbandry used in Brabant and Flanders. With an Appendix. 1651. 4to. Lond.
  3. Appendix to the Legacy, relating more particularly to the Husbandry and Natural History of Ireland. Lond. 1651. 4to.
  4. Essay on the Advancement of Husbandry and Learning, with propositions for erecting a College of Husbandry. Lond. 1651. 4to.
  5. The Reformed Husbandman; or, a brief Treatise of the Errors, Defects, and Inconvenience of our English Husbandry, in ploughing and sowing for Corn; with the Reasons and general Remedies, And a large, yet faithful Offer or Undertaking for the Benefit of them that will join in this good and public Work. Lond. 1651. 4to.
  6. Design for Plenty, by a Universal Planting of Trees; tendered by some well-wishers to the Public. Lond. 1652. 4to.
  7. Discovery for Division or Setting out of Waste Land in England and Ireland. Lond. 1653. 4to.
  8. The Complete Husbandman; or, a Discourse of Husbandry, both Foreign and Domestic. And a particular Discourse of the Natural History of Husbandry in Ireland. Lond. 1559. 4to.
1649. *Bliith, Walter*, an officer in Cromwell's army, who, with other English gentlemen holding commissions at that time, was eminently useful in introducing improvements into Ireland and Scotland.
1. The English Improver, discovering that some Land, both Arable and Pasture, may be advanced Double and Treble, and some Five and Ten-fold. Lond. 4to the Reasons and numerous engravings.
  2. The English Improver improved, or the Survey of Husbandry surveyed. Lond. 1652. 4to.
1661. *Evelyn, John*, F.R.S. An eminent philosopher and patriot, particularly skilled in natural history and the fine arts, was born at Wotton, his father's seat, in 1620; and died, and was interred there, in 1705-6.
1. *Sylva*; or, a Discourse of Forest Trees. Lond. 1664. fol. Dr. Hunter, of York, published an edition with copious notes and numerous engravings.
  2. *Terra*; a Philosophical Discourse of Earth, relating to the Culture and Improvement of it for Vegetation, and the Propagation of Plants, as it was presented to the Royal Society, April 29, 1675. Lond. 1675. fol.
  3. *Pomona*; a Discourse concerning Cider. Lond. 1679. fol.
  4. A Spanish Drill Plough. (*Phil. Trans. Abr. i.* 457.) 1670.
1663. *Strangchopes, Samuel*.  
Book of Knowledge, in Three Parts; concerning Astrology, Physic, and Husbandry. Lond. 8vo.
1665. *Dodson, Colonel William*.  
The Design for the perfect Draining of the great Level of the Fen, called Bedford Level, with Maps, &c. Lond. 4to.
1667. *Cavendish, William*, Marquis and Duke of Newcastle.  
A New Method and extraordinary Invention to dress Horses, and work them according to Nature; as also to perfect Nature by the subtilty of Art. Lond. fol.
1669. *Wortidge, John*, gentleman, author of some works on gardening.
1. *Systema Agriculturae*, &c. Lond. fol.
  2. Treatise of Husbandry. Lond. 1675. fol.
1670. *Smith, or Smyth, John*, commonly called Captain John Smith, Governor of the English Plantations, was born at Willoughby, in the county of Lincoln; died 1631.
- England's Improvement revived, plainly discovering the several ways of improving the several Sorts of waste and barren Grounds, and of enriching all Earths, with the natural Quality of all Lands, and the several Seeds and Plants which naturally thrive therein observed, together with the Manner of planting all Sorts of Timber Trees, and Underwoods, experienced in 30 Years' Practice; in 6 Books, Lond. 4to.
1670. *Reeve, Gabriel*.  
Directions to his Son for the Improvement of Barren and Heathy Land in England and Wales, Lond. 4to.
1675. *Kirby, Christopher*.  
Strange Effect of Thunder and Lightning on Wheat and Rye in the Granaries of Dantzic. (*Phil. Trans. Abr. ii.* 89.)
1674. *Coxe, Daniel*, M.D.  
Improvement of Cornwall by Sea sand. (*Phil. Trans. Abr. ii.* p. 206.)
1679. *Beal, Dr. John*, an ingenious English divine and philosopher, was born in Herefordshire, 1603; died 1683.
- Agrestic Observations and Advertisements. N. 374 and 384.
1678. *Howard, Hon. Charles*, of Norfolk.  
On the Culture or Planting and Ordering of Saffron. (*Phil. Trans. Abr. ii.* 423.)
1681. *Langford, T.* author of some tracts on fruit trees.
- Systeme Agriculture*; being the Mystery of Husbandry discovered. Lond. fol.
1681. *Houghton, John*, F.R.S.
1. A Collection of Letters for the Improvement of Husbandry and Trade. Lond. 4to.
  2. Collections for the Improvement of Husbandry, relating to Corn.
  3. A Catalogue of all Sorts of Earths; the Art of Draining, or Brewing, the Instruments of Husbandry; revised by R. Bradley. Lond. 1727-8. 4 vols. 8vo.
1683. *Lister, Martin*, M.D. an eminent physician and natural philosopher, was born in Buckinghamshire about 1638, practised in London; died 1711-12. He wrote various works.
1. On the Salt Springs of Worcestershire, Staffordshire, and Cheshire, with speculations respecting Salt, &c. (*Phil. Trans. Abr. iii.* 10.)
  2. Of Plants which may be usefully cultivated for grass or hay. 1696. (*N. Abr. iv.* 136.)
1684. *Beaumont, John*.  
On a new way of Clearing Rocks. (*Phil. Trans. Abr. iii.* p. 115.)
1685. *Moore, Sir Jonas*, Knight, F.R.S., a very respectable mathematician and surveyor general of his Majesty's ordnance, was born in Lancashire, 1617; died 1679.
1. History or Narrative of the great Level of the Fens called Bedford Level; with a large Map of the said Level, as drained, surveyed, and described. 8vo.
  2. England's Interest, or the Gentleman and Farmer's Friend. Lond. 1703. 8vo.
1694. *Floyd, Edward*.
1. Account of Locusts in Wales. (*Phil. Trans. Abr. iii.* p. 617.)
  2. On the spontaneous Combustion of several Hay Stacks, &c. (*Ib.* p. 618.)
1697. *Donaldson, James*, a native of Scotland, and one of the earliest and most useful writers on the agriculture of his country.
- Enquiry into the present manner of Tilling and Manuring the Ground in Scotland. Edin. 12mo.
1699. *Meager Leonard*, author of *The English Gardener* and other works.  
The Mystery of Husbandry. Lond. 12mo.
1707. *Mortimer, John*, author of some tracts on religious education. His works on husbandry were translated into Swedish, and published, in Stockholm, in 1727.
- The whole Art of Husbandry in the way of Managing and Improving Land. Lond. 8vo.
1717. *Laurence, Edward*, brother to John Laurence, a clergyman, author of a work on gardening. (See A. D. 1726.)
- The Duty of a Steward to his Lord; with an Appendix on Farming. Lond. 1727. 4to.
1718. *Barham, Henry*.
1. Experiments and Observations on the Production of Silk Worms in England. (*Phil. Trans. Abr. vi.* p. 426.)
  2. An Essay upon the Silk Worm. Lond. 1719. 8vo.
  3. Observations on their Productions, and of the Silk in England. 1719. (*Phil. Trans. Abr. vi.* 426.)
1718. *Switzer, Stephen*, an eminent gardening author, layer out of gardens, and also a seedsman in Westminster; died 1745. (See *Encyc. of Gard.* page 1102.)
- Directions for Burning Clay for Manure. Lond. 8vo. with a plate of the Kiln.
1721. *Bradley, Richard*, F.R.S. and Professor of Botany in the University of Cambridge, a most voluminous writer on gardening, botany, &c.; died 1732. (*Encyc. of Gard.* p. 1102.)
1. Philosophical Treatise of Husbandry and Gardening. Lond. 4to.
  2. The Country Gentleman and Farmer's Monthly Director. Lond. 1721. 8vo.
  3. Treatise concerning the Manner of Following Ground, raising of Grass, Seeds, and Training of Lint and Hemp. Lond. 1724. 4to.
  4. A Survey of Ancient Husbandry and Gardening, collected from the Greeks and Romans; 4 Plates. Lond. 1725. 8vo.
  5. General Treatise of Husbandry and Gardening. Lond. 1726. 2 vols. 8vo.
  6. Experimental Husbandman and Gardener. Lond. 1726. fol.
  7. A Complete Body of Husbandry. Lond. 1727. 8vo.
  8. The Weekly Miscellany for the Improvement of Husbandry, Arts, and Sciences. 21 Nos. 1727. 8vo.
  9. The Science of Good Husbandry, or the Economy of Xenophon, translated from the Greek. Lond. 1727. 8vo.
  10. The Riches of a Hop Garden explained, with the Observations of the most celebrated Hop Planters in Britain. Lond. 1729. 8vo.
1723. *Salmon, William*, M.D. a noted empiric, who lived about the latter end of the 17th and beginning of the 18th century.

- Choice Experiments, and Observations on Building, Husbandry, &c. Lond. 8vo.
1753. *Molesworth, Robert*, Viscount, ambassador of William III. to the Danish court; born at Dublin, 1756; died 1725.
- Considerations for Promoting Agriculture. Dublin.
1724. *Benson, William*, A.M. of Oxford, a critic of some fame: was born in London 1682; died 1754.
- Virell's Husbandry; with Notes Critical and Rustic. Lond. 1726.
- Lawrence, John*, M.A. author of *The Clergyman's Recreation*, a gardening work of use in its time; he died in Durham, 1732. (*Encyc. of Gard.* p. 1102.)
- The New System of Agriculture, being a complete Body of Husbandry and Gardening in all the parts of them. Lond. fol.
1729. *Mackintosh, Roland*.
- Essay on Ways and Means for Inclosing, Fallowing, Planting, &c. Scotland, and that in sixteen years at farthest. Edin. 8vo.
1730. *Richards, John*.
- The Gentleman's Steward and Tenant of Manors instructed. Lond. 8vo.
1730. *Rye, George*.
- Observations on Agriculture. Dub. 8vo.
1731. *Tull, Jethro*, was born in Oxfordshire; he was a barrister, and made the tour of Europe; after which he settled on his paternal estate, which he cultivated with so much attention as brought on a disorder in his breast; he then went abroad, and on his return, fixed his residence on a farm in Berkshire, where he renewed his experiments in horse-hoeing husbandry; he died in 1740. His son, John Tull, was an officer in the army, but ruined himself by projects, and died in the Fleet, in 1764. (*Genl. Mag.*)
1. Specimen of a Work on Horse-hoeing Husbandry. Lond. 4to.
  2. New Horse-hoeing Husbandry; or an Essay on the Principles of Tillage and Vegetation, wherein is shown a Method of introducing a sort of Vineyard Culture into the Corn Fields in order to increase their Product, and diminish the common Expence by the use of Instruments, described in Cuts, 1733. fol.
  3. Supplement to the New Horse-hoeing, &c. Lond. 1739.
1732. *Ellis, William*, a farmer at little Gaddesdon, near Hempstead in Hertfordshire.
1. Practical Farmer, or Hertfordshire Husbandman. Lond. 8vo.
  2. Chiltern and Vale Farming explained. Lond. 1733. 8vo.
  3. New Experiments in Husbandry. Lond. 1736. 2 vols. 8vo.
4. The Timber Tree Improved. Lond. 1738. 8vo.
5. The Modern Husbandman; or, Practice of Farming. Lond. 1744. 8vo.
6. The Country Housewife's Family Companion. Lond. 1750. 8vo.
7. The Complete Planter and Cyderist. Lond. 1757. 8vo.
8. Ellis's Husbandry abridged and methodized. Lond. 1772. 2 vols. 8vo.
1737. *Albin, Eleaser*.
1. Natural History of English Song Birds, and other Foreign ones as are esteemed for their singing, with the Cock, Hen, and Egg of each Species. Lond. 8vo.
2. The History of Esculent Fish. 1794. 4to.
1737. *Phillips, Robert*.
- Dissertation concerning the present State of the High Roads of England, especially those near London, wherein is proposed, a New Method of repairing and maintaining them. Lond. 8vo.
1739. *Trowel, Samuel*.
- Treatise of Husbandry and Gardening. Lond. 8vo.
1744. *Clavidge, John*.
- The Shepherd of Banbury's Rules to know of the Change of the Weather. Lond. 8vo.
1756. *White, Stephen*, M.A., Rector of Holton, in Suffolk.
- Collateral Bee-boxes, &c. Lond. 8vo.
1757. *Home, Francis*, M.D., Professor of Materia Medica in the University of Edinburgh.
- The Principles of Agriculture and Vegetation. Lond. 8vo.
1757. *Liste, Edward*, Esq., late of Crux-Easton, in Hampshire.
- Observations on Husbandry. Lond. 2 vols. 8vo.
1759. *Stillingfleet, Benjamin*, grandson to the bishop of that name, and an ingenious naturalist and miscellaneous writer, was born about 1702, died 1771.
1. Miscellaneous Tracts relating to Natural History, Husbandry, and Physic. Translated from the Latin; with notes. Lond. 8vo.
  2. Calendar of Flora, Swedish and English, made in the year 1755. Lond. 8vo. 1761.
1759. *Mills, John*, F.R.S., author and translator of several works, and among others of *Gyllinborg's Natural and Chemical Elements of Agriculture*, an ingenious work for its time and country.
1. A Practical Treatise of Husbandry. Lond. 4to.
  2. A New and Complete System of Practical Husbandry. Lond. 1763-5, 5 vols. 8vo.
  3. An Essay on the Management of Bees. Lond. 1766. 8vo.
  4. An Essay on the Weather; with Remarks on the Shepherd of Banbury's Rules for Judging of its Changes, and Directions for Preserving Hives and Buildings from the fatal effects of Lightning. Lond. 1770. 8vo.
  5. A Treatise on Cattle, &c. Lond. 1776. 8vo.

1760. *Hitt, Thomas*, gardener to Lord Manners, at Bloxholme in Lincolnshire, and author of a meritorious work on fruit trees.
- A Treatise of Husbandry; or the Improvement of Dry and Barren Lands. Lond. 8vo.
1760. *North, Richard*, nursery gardener, near Westminster Bridge Road, Lambeth. (*Encyc. of Gard.* 1805.)
- An Account of the different kinds of Grasses propagated in England, for the Improvement of Corn and Pasture Lands. Lond. 8vo.
1761. *Rocque, Bartholomew*, market gardener at Walham Green, London. By advertisements and other means, he brought the burnet into undeserved repute. He sowed different sorts of grasses, and when they had formed a turf, he sold them as specimens by the square inch. (*Encyc. of Gard.* 1104.)
1. A Practical Treatise on Cultivating Lucerne Grass. Lond. 4to.
  2. Some Hints relative to Burnet and Timothy Grasses. Lond. 1764. 8vo.
1761. *Wark, Dr. David*, Minister of Haddington.
- On the Use of Furze in Fencing the Banks of Rivers. (*Phil. Trans.* xi. 514.)
1761. *Mordant, John*.
- The Complete Steward; or the Duty of a Steward to his Lord. Lond. 2 vols. 8vo.
1762. *Dickson, Adam*, A.M., minister of Dunse in Scotland. Considered a good classical scholar, and an excellent practical farmer. He died before *The Husbandry of the Ancients* was prepared for the press, which is the occasion of some defects in that work.
1. Treatise on Agriculture. Edin. 8vo. This is one of the best works on tillage that ever has appeared.
  2. The Husbandry of the Ancients. Edin. 1778. 2 vols. 8vo.
1764. *Ladnar, of Kroy*, in Yorkshire.
- The Farmer's New Guide. Lond. 8vo.
1764. *Randall, J.*, some time master of the Academy at Heath, near Wakefield, Yorkshire.
1. The Semi-Virgilian Husbandry, deduced from various experiments. Lond. 8vo.
  2. Construction and extensive Use of a new invented Seed Furrow Plough, suited to all Soils; of a Draining Plough, and of a Potatoe Drill Machine; with the Theory of a Common Plough; illustrated with 7 plates. Lond. 1764. 4to.
1765. *Fordyce, George*, M.D., F.R.S., a distinguished physician, and teacher of medicine in London, was born at Aberdeen, 1736; died 1802.
- Elements of Agriculture and Vegetation. Edin. 8vo.
1766. *Morgan, John*, M.D., F.R.S.; died at Philadelphia, 1789.
- Essay on the Expressing of Oil from Sun Flower Seed, &c. (*Trans. Amer. Soc.* i. 306.)
1766. *Homer, Henry*, an excellent classical scholar, was born in Warwickshire, 1752; died 1791.
1. An Essay on the Nature and Method of ascertaining the specific Shares of Proprietors upon the Inclosure of Common Fields. Lond. 8vo.
  2. An Inquiry into the Means of Preserving and Improving the Public Roads of this Kingdom. Oxf. 1767. 8vo.
1767. *Young, Arthur*, F.R.S., an eminent agriculturist, Secretary to the Board of Agriculture, was the son of Arthur Young, a prebend of Canterbury, and author of *An Historical Dissertation of Corruptions in Religion*. He was born in 1741. He served his apprenticeship to a wine merchant; but on entering into the possession of his paternal estate, near Bury St. Edmunds, he became a farmer; and impoverished himself by experiments. After this he set up as a teacher of others; and in 1770, published a volume called *The Farmer's Calendar*; which was followed by a periodical work, entitled *The Annals of Agriculture*, in which he had the honor of having his late Majesty for a correspondent. Young also made excursions through the British islands, and on the continent, to collect information on subjects of rural economy. At length a Board of Agriculture was established, of which he was appointed secretary, with a salary of six hundred a year. He became blind some years before his death, which happened February 20, 1820. His works are numerous, and his travels amusing. (*Annual Biography*.)
1. The Farmer's Letters to the People of England, &c. Lond. 8vo.
  2. The Farmer's Letters to the Landlords of Great Britain. Lond. 1771. 8vo.
  3. A Six Weeks' Tour through the Southern Counties of England and Wales. Lond. 1768. 8vo.
  4. Treatise on the Management of Hogs. Lond. 1769. 8vo.
  5. A Six Months' Tour through the North of England. Lond. 1770. 4 vols. 8vo.
  6. The Farmer's Guide in Hiring and Stocking Farms, &c. Lond. 1770. 2 vols. 8vo.
  7. Rural Economy; or Essays on the Practical Part of Husbandry. Lond. 1770. 8vo.
  8. A Course of Experimental Agriculture. Lond. 1770. 2 vols. 4to.
  9. The Farmer's Tour through the East of England. Lond. 1770. 4 vols. 8vo.



10. Observations on the Present State of the Waste Lands in Great Britain. Lond. 1772. 8vo.
11. Tour in Ireland; with General Observations on the Present State of that Kingdom, made in 1776-7-8 and 9. Dub. 1780. 2 vols. 8vo.
12. An Essay on the Culture of Cole-seed for feeding Sheep and Cattle. 8vo.
13. Annals of Agriculture, and other useful Arts. Published in Nos. Bury St. Edmunds, 1790, 40 vols. 8vo.
14. Travels during the years 1787-8 and 9, undertaken more particularly with a View of ascertaining the Cultivation, Wealth, Resources, and National Prosperity of the Kingdom of France. Bury St. Edmunds, 1792. 4to. 2 vols.
15. General View of the Agriculture of the County of Suffolk; drawn up for the Board of Agriculture. Lond. 1797. 8vo.
16. General View of the Agriculture of the County of Lincoln; drawn up for the Board of Agriculture. Lond. 1799. 8vo.
17. An Enquiry into the Propriety of applying Wastes to the Maintenance and Support of the Poor. Lond. 1801. 8vo.
18. The Farmer's Kalender, containing the Business necessary to be performed on the various kinds of Farms during every month of the year. Lond. 1800. 4 vols. 8vo.
19. Essay on Manures, &c. 1804. 8vo.
20. General View of the Agriculture of Hertfordshire; drawn up for the Board of Agriculture. Lond. 1804. 8vo.
21. General View of the Agriculture of the County of Norfolk. Lond. 1804. 8vo.
22. General View of the Agriculture of the County of Essex. Lond. 1806. 2 vols. 8vo.
23. General Report on Inclosures. Lond. 1807. 8vo.
24. General View of the Agriculture of Oxfordshire. Lond. 1808. 8vo.
25. A General View of the Agriculture of the County of Sussex; drawn up for the Board of Agriculture. Lond. 1808. 8vo.
26. Advantages which have resulted from the Establishment of the Board of Agriculture. Lond. 1809. 8vo.
27. On the Husbandry of those celebrated British Farmers Bakewell, Arbutnot, and Duckett. Lond. 1811. 8vo.
1768. *Wildman, Thomas*.  
Treatise on the Management of Bees. Lond. 4to.
1768. *Wall, Richard*.  
A Dissertation on Breeding Horses, upon Philosophical and Experimental Principles; being an attempt to promote thereby the Breed of Racers and Horses in general; with some observations on Foreign Horses. Lond. 8vo.
1768. *Dossie, Robert, Esq.*  
Memoirs of Agriculture, &c. Lond. 3 vols. 8vo.
1769. *Weston, Richard, Esq.*, an amateur cultivator in the country, and afterwards a tract writer in London; died about the beginning of the present century.
1. Tracts on Practical Agriculture and Gardening. Lond. 8vo.
2. Tracts on Alabaster, or Gypsum, describing its powerful effects as a very cheap manure, &c. Lond. 1791. 8vo.
1770. *Peters, Matthew*.  
1. The National Farmer. Lond. 8vo.  
2. Winter Riches. Lond. 1771. 8vo.
1770. *Comber, Thomas, LL.D.*, Rector of Buckworth and Morborne, in Huntingdonshire, died 1778.
1. Free and candid Correspondence on the Farmer's Letters to the People of England, &c., with the Author and Arthur Young, Esq. Lond. 8vo.
2. Real Improvement in Agriculture, on the principles of A. Young, Esq. To which is added, a Letter to Dr. Hunter of York, on the Rickets in Sheep. Lond. 1772. 8vo.
1770. *Hunter, Alexander, M.D., F.R.S.L. and E.* was born at Edinburgh, 1733; settled as a physician at Gainsborough, at Beverley, and finally at York, where he died, 1809.
1. Geographical Essays; in which the Food of Plants is particularly considered. Lond. 4 vols. 8vo.
2. Outlines of Agriculture. York, 1785. 8vo.
3. A New Method of raising Wheat for a series of years on the same land. York, 1796. 4to.
1771. *Baker, John Wynn*.  
Experiments in Agriculture, made under the Direction of the Dublin Society, in 1769 and 1770. Dub. 8vo.
1774. *Ringsted, Josiah, Esq.*  
1. The Cattle Keeper's Assistant. Lond. 8vo.  
2. The Farmer; comprehending the most interesting objects, and beneficial practices, in the Culture of Wheat, Rye, Barley, Oats, Buckwheat, &c. Lond. 1796. 8vo.
1774. *Varlo, C. Esq.*  
A New System of Husbandry. Lond. 3 vols. 8vo.
1774. *Barron, William, F.R.S.E.*, Professor of Logic and Belles Lettres in the University of St. Andrews.  
1. Essays on the Mechanical Principles of the Plough. Edin. 8vo.
1775. *Kent, Nathaniel*, of Fulham, Middlesex. He studied agriculture in Flanders, and became an eminent land valuer and agent. He was also for sometime farm bailiff to George III. He died in 1818.
1. Hints to Gentlemen of Landed Property. Lond. 8vo.
2. General View of the Agriculture of the County of Norfolk; drawn up for the Board of Agriculture and Internal Improvement. Norwich, 1796. 8vo.
3. Account of the Improvements made on the Farm in the Great Park of His Majesty the King, at Windsor. (*Nicholson's Journal*, iii. 428.) 1799.
1775. *Harrison, Gustavus, Esq.*  
Agriculture Delineated; or, the Farmer's Complete Guide, being a Treatise on Lands in General. 8vo.
1775. *Anderson, James, LL.D.*, an eminent agri-

cultural writer, was born at Hermiston, a village near Edinburgh, in 1730, on a farm which his parents had possessed for some generations, and which he was intended to inherit and to cultivate. He lost his parents at an early age, but his education was not neglected; he studied chemistry under Dr. Cullen, and soon leaving his farm near Edinburgh, took one in Aberdeenshire of 1300 acres, which, after improving and cultivating for twenty years, he let, and enjoyed an annuity from it during his life. He settled after leaving Aberdeenshire, in the neighborhood of Edinburgh, where he published the *Bee*, in weekly sixpenny numbers, till it extended to 18 volumes. In 1797, he removed to Isleworth, near London, where he published *Recreations in Agriculture*, in six volumes, and his *Description of a Patent Hothouse*. Here he enjoyed his garden, and died of a decline in 1808, aged 69. Besides the works which bear his name, he wrote the reviews of books on rural matters for the *Monthly Review* for many years.

1. Essays relating to Agriculture and Rural Affairs. Edin. 8vo. 1765. 8vo.
2. Miscellaneous Thoughts on Planting and Training Timber Trees, by Agricola. Edin. 1777. 8vo.
3. An Account of the Present State of the Hebrides and Western Coasts of Scotland, with Hints for encouraging the Fisheries, and promoting other Improvements in these countries; being the Substance of a Report to the Lords of the Treasury. Edin. 1785. 8vo.
4. A Practical Treatise on Peat Moss, considered as in its Natural State fitted for affording Fuel, or as susceptible of being converted into Mould, capable of yielding abundant Crops of useful Produce, with full Directions for converting and cultivating it as a Soil. Edin. 1794. 8vo.
5. A General View of the Agriculture and Rural Economy of the County of Aberdeen, with Observations on the Means of its Improvement. Chiefly drawn up for the Board of Agriculture, in two parts. Edin. 1794. 8vo.
6. A practical Treatise on Draining Bogs and Swampy Grounds; with cursory Remarks on the Originality of Elkington's mode of Draining. Lond. 1794. 8vo.
7. Recreations in Agriculture, Natural History, &c. &c. Lond. 1799. 6 vols. 8vo.

1776. *Home, Henry*, usually called Lord Kames, an eminent Scotch lawyer, philosopher, and critic, was born at Kames, in Berwickshire, 1796; died 1782. He farmed his own estate in Berwickshire many years; he afterwards removed to Blair Drummond, near Stirling, where he made various and extensive improvements, the most important of which was the clearing, cultivating, and peopling great part of Flanders Moss. (See 4196.)

1. The Gentleman Farmer; being an attempt to improve Agriculture, by subjecting it to the test of Rational Principles. Edin. 8vo.
2. Observations concerning Shallow Ploughing. (*Ess. Phys. and Lit.* iii. c. 68.)

1777. *Clarke, Cuthbert*.  
The true Theory and Practice of Husbandry, deduced from Philosophical Principles and Experiments, &c. Lond. 4to.

1778. *Forbes, Francis*, gentleman.  
1. The extensive Practice of the New Husbandry. Lond. 8vo.

2. The Improvements of Waste Lands. Lond. 1778. 8vo.

1778. *Wight, Andrew*, a farmer in East Lothian, and one of the earliest writers among that class in Scotland.

- The Present State of the Husbandry in Scotland. Edin. 6 vols. 8vo.
1778. *Black, James*, of Morden, Surrey.  
Observations on the Tillage of the Earth, and on the Theory of Instruments adapted to this end. Lond. 4to.

1778. *Marshal, William, Esq.*, a native of Yorkshire, brought up to trade; he was some years in the West Indies, as a planter; returned about 1775, and took a farm in Surrey; went down into Norfolk as agent to Sir Harbord Harbord's estate in 1780; he left this situation in 1784, and went and resided at Stafford, near the junction of the four counties of Leicester, Warwick, Stafford, and Derby, where he remained till 1786, occupied in collecting materials for his *Economical Surveys*, and in printing some of his works. From this time till about 1808, he resided chiefly in Clement's Inn, London, in winter, and visited different parts of the country during summer. He spent one summer in Perthshire, chiefly on the Earl of Breadalbane's estates at Taymouth; and partly also on the Earl of Mansfield's at Scone. He proposed arrangements for the tenable land, and also the park and woody scenery on various estates; and finally retired to a considerable property he purchased in his native country, in the vale of Cleveland, in 1808, where he died at an advanced age in 1819. He was a man of little education, but of a strong and steady mind; and pursued in the most consistent manner, from the year 1780 to his death, the plan he originally laid down; that of collecting and condensing the agricultural practices of the different counties of England, with a view to a general work on *Landed Property*, which

he published; another on *Agriculture*, which he did not live to complete; and a *Rural Institute*, in which he was supplanted by the Board of Agriculture.

1. Minutes of Agriculture, made on a Farm of 300 acres, of various soils, near Croydon, Surrey. Lond. 4to.

2. Experiments and Observations concerning Agriculture and the Weather. Lond. 1779. 4to.

3. The Rural Economy of Norfolk. Lond. 1788. 2 vols. 8vo.

4. The Rural Economy of Yorkshire. Lond. 1788. 2 vols. 8vo.

5. The Rural Economy of Gloucestershire. Glouc. 1789. 2 vols. 8vo.

6. Rural Economy of the Midland Counties. Lond. 1790. 2 vols. 8vo.

7. Rural Economy of the West of England. Lond. 1796. 2 vols. 8vo.

8. The Rural Economy of the Southern Counties of England. Lond. 1798. 2 vols. 8vo.

9. Proposals for a Rural Institute, or College of Agriculture, and other Branches of Rural Economy. Lond. 1799. 8vo.

10. On the Appropriation and Enclosure of Commonable and Intermixed Lands. Lond. 1801. 8vo.

11. An Elementary and Practical Treatise on the Landed Property of England, containing the Purchase and Improvement of Landed Estates. Lond. 1804. 4to.

12. Treatise on the Management of Landed Estates. A General Work for the Use of Professional Men, being an Abridgment of the former. Lond. 1808. 8vo.

13. A Review and Complete Abstract of the Reports of the Board of Agriculture from the several Departments of England. Lond. 1817. 5 vols. 8vo.

14. Of the Black Canker Caterpillar which destroys the Turnips in Norfolk. (*Phil. Trans. Abr. xv. 386.*) 1785.

1779. *Girton, Daniel*, of the county of Bucks.

The Complete Pigeon Fancier; or a New Treatise on Domestic Pigeons; containing the most valuable Information concerning the Nature, Properties, and Management of all their various Species. Lond. 12mo. Plates.

1780. *Trusler, Rev. John, LL.D.*, author of a great variety of petty works on education, morals, manners, and domestic economy. He was also a farmer for some time. He published his works on his own account, and by prudent conduct, lending his money at annuity interest, speculating on the leases of houses, &c., contrived to realize a considerable property, and for many years before his death to keep his carriage and live in a very gentlemanlike style at Bath.

1. Practical Husbandry, or the Art of Farming with a Certainty of Gain. Lond. 8vo.

2. On the Importance of a Farmer's Life, 1795. 8vo.

1780. *Boswell, George*, a cultivator of his own estate in Gloucestershire.

Treatise on Watering Meadows; wherein are shown the many Advantages arising from that mode of Practice, particularly on coarse, boggy, or barren Lands. Lond. 8vo.

1783. *Raley, William*.

A Treatise on the Management of Potatoes. Lond. 8vo.

1784. *Small, James*, a plough-wright and small farmer in Roxburghshire; but afterwards settled at Edinburgh as an agricultural machinist.

Treatise on Ploughs and Wheel Carriages. Edin. 8vo.

1784. *Turner, Nicholas*.

An Essay on Draining and improving Peat Bogs. Lond. 8vo.

1784. *Cooke, James*, a clergyman of Norfolk, inventor of a new drill machine, for a long time deservedly popular, and still preferred to most others for drilling the cereal grasses, and hoeing between the rows.

Drill Husbandry Perfected. 12mo.

1785. *Stone, Thomas*, lately a surveyor and land-agent to the Duke of Bedford, died at Paris 1815.

1. An Essay on Agriculture, with a View to inform Gentlemen of landed Property whether their Estates are managed to the greatest Advantage. Lond. 8vo.

2. General View of the Agriculture of the County of Huntingdon. Lond. 1795. 4to.

3. General View of the Agriculture of the County of Bedford. Lond. 1794. 4to.

4. General View of the Agriculture of the County of Lincoln. Lond. 1794. 4to.

5. A Review of the corrected Agricultural Survey of Lincolnshire, by Arthur Young, Esq. Lond. 1800. 8vo.

6. A Letter on the Drainage of the East, West, and Wild Moor Fens. Lond. 1800. 8vo.

7. Letter on the intended Drainings and Inclosures of the Moor Fens in the County of Lincoln. 1801.

1786. *Horne, or Horn, John*.

The Description and Use of a New-invented Patent Universal Sowing Machine, for Broadcasting or Drilling every kind of Grain, Pulse, and Seed. Lond. 8vo.

1786. *Young, David*, of Perth.

Natural Improvements in Agriculture, in Twenty-seven Essays. Edin. 8vo.

1786. *Culley, George*, born at Denton, in the county of Durham. In 1762 he went to Dishley and remained some time a pupil with Bakewell; he then returned and took the farm of Penton, in Northumberland, in 1767, and died in that county, at Fowberry tower, in 1813, aged 79.

1. Observations on Live Stock; containing Hints for chusing and improving the best Breeds of the most useful kinds of Domestic Animals. Lond. 8vo.

2. General View of the Agriculture of Northumberland. (See Bailey, J. A. D. 1797.)

1787. *Ley, Charles*, land surveyor.

The Nobleman, Gentleman, Land Steward, and Surveyor's Complete Guide; in which is described every Circumstance relative to the proper Management of Estates; comprehending the Duty and Office of a Land Steward in all its Parts; with some useful Hints to Surveyors; also the Current Prices of Estates throughout the Kingdom, by which any Gentleman or Steward may ascertain the exact Value of any Estate whether in Fee, Copy, or Leasehold. Lond. 8vo.

1787. *Winter, George*, a practical agriculturist.

A new and compendious System of Husbandry; containing the mechanical, chemical, and philosophical Elements of Agriculture. Edin. 8vo.

1789. *Falconer, William*, M.D. F.R.S. physician to the General Hospital, Bath, author of several agreeable and interesting works on natural philosophy, in which he has distinguished himself by generalizing the subjects treated of.

An Essay on the Preservation of the Health of Persons employed in Agriculture; and on the Cure of Diseases incident to that way of Life. Lond. 8vo.

1789. *Adam, James*, Esq.

Practical Essays on Agriculture. Lond. 2 vols. 8vo.

1789. *Bertzen, S.*

Thoughts on the different kinds of Food given to young Silk Worms, and the Possibility of their being brought to Perfection in the Climate of England, founded on Experiments made near the Metropolis. Lond. 8vo.

1789. *Wright, Rev. Thomas*, Rector of Auld, in Northamptonshire.

1. Account of the Advantages and Method of Watering Meadows by Art, as practised in the County of Gloucester. Lond. 8vo.

2. The Art of Floating Land, as it is practised in the County of Gloucester, shown to be preferable to any other Method in use in this Country; with minute and plain Directions, and Three descriptive Plates. Lond. 1799. 8vo.

3. On the Formation and Management of Floated Meadows; with Corrections of Errors found in the Treatises of Messrs. Davis, Marshall, Boswell, Young, and Smith, on the Subject of Floating. 1810. 8vo.

1790. *Naismith, John*, an ingenious cultivator in Clydesdale.

1. Thoughts on various Objects of Industry pursued in Scotland. Edin. 8vo.

2. General View of the Agriculture of the County of Clydesdale. 4to. 1794.

3. Observations on the different Breeds of Sheep, and the state of Sheep Farming in the Southern Districts of Scotland. Edin. 1795. 4to.

4. Elements of Agriculture; being an Essay towards establishing the Cultivation of the Soil, and promoting Vegetation on steady Principles. Lond. 1807. 8vo.

1790. *Curtis, William*, an eminent botanist, born in Hampshire, 1746, died 1799; author of various works on practical botany and the culture of plants.

Practical Observations on the British Grasses best adapted to the laying down or improving of Meadows and Pastures. Lond. 8vo.

1790. *Swayne, G. A. M.* Vicar of Pucklechurch, Gloucestershire.

Gramina Pasca; or, a Collection of the Specimens of the Common Pasture Grasses. Lond. fol. 8 pages, and 6 plates.

1790. *Sinclair, Right Hon. Sir John*, Bart. LL.D. M.P. Founder of the Board of Agriculture, author of *The Code of Health and Longevity*, and various other ponderous compilations.

1. Report on the Subject of Shetland Wool. Lond. 8vo.

2. Address to the Society for the Improvement of British Wool, constituted at Edinburgh, 1791. Lond. 8vo.

3. Account of the Origin of the Board of Agriculture, and its Progress for Three Years after its Establishment. Lond. 1796. 4to.

4. Enquiry into the Nature and Causes of the Blight, the Rust, and the Mildew. 1809. 8vo.

5. An Account of the Systems of Husbandry adopted in the more improved Districts of Scotland; with some Observations on the Improvements of which they are susceptible. Edin. 1812. 8vo., with numerous plates.

6. The Agriculture of the Netherlands. 1816. 8vo.

7. The Code of Agriculture. 8vo. 1820.

1792. *May, Thomas*.

Minutes of Agriculture, and the Description of Machines and Implements of Husbandry, in reply to Cooke's Annotations. Lond. 8vo.

1792. *Clarke, Charles*.

Treatise on the Earth called Gypsum. Lond. 8vo.

1793. *Claridge, John*, of London, an eminent land valuer and agent.

General View of the Agriculture of the County of Dorset. Lond. 4to.

1793. *Elstobb, W.*

Historical Account of the great Level of the Fens, called Bedford Level, and other Fens, Marshes, and low Lands in this Kingdom, and other Places. Lynn, 8vo.

1793. *Fullarton, Colonel*.

General View of the Agriculture of the County of Ayr; with Observations on the Means of its Improvement. Edin.

1793. *Lebrocq, Philip*, M.A. and curate of Ealing.

The Outlines of a Plan for improving the Tract of Land called the New Forest. Lond. 8vo.

1793. *Fraser, Robert*, Esq.

1. General View of the Agriculture of the County of Devon. Lond. 4to.

2. General View of the Agriculture and Mineralogy, present State and Circumstances, of the County of Wicklow. Dub. 1801. 8vo.

3. Gleanings in Ireland; particularly respecting its Agriculture, Mines, and Fisheries. Lond. 1802. 8vo.

4. A Letter on the most effectual Means for the Improvement of the Coasts and Western Islands of Scotland, and the Extension of the Fisheries. Lond. 1805. 8vo.
5. Statistical Survey of the County of Wexford. Dublin. 1807. 8vo.
1794. *Robson, James*.  
General View of the Agriculture of the County of Argyle, and of the Western Part of the County of Inverness. Lond. 4to.
1794. *Rennie, George*, Esq. an eminent East Lothian farmer, and also a proprietor.  
General View of the Agriculture of the West Riding of Yorkshire, by Messrs. Rennie, Brown, and Shirreff. Lond. 4to.
1794. *Quayle, Basil*.  
A General View of the Agriculture of the Isle of Man. Lond. 4to.
1794. *Pringle, A.*  
General View of the Agriculture of the County of Westmorland. Edin. 4to.
1794. *Pomeroy, William Thomas*.  
General View of the Agriculture of the County of Worcester. Lond. 4to.
1794. *Pearce, William*, a land valuer and agent in London.  
General View of the Agriculture of Berkshire. Lond. 8vo.
1794. *Malcolm, W. J. and J.* (ingenious land surveyors) brothers to the London nurseryman of that name.  
1. General View of the Agriculture of Buckinghamshire. Lond. 4to.  
2. General View of the Agriculture of the County of Surrey. Lond. 1794. 4to.
1794. *Low, Robert*, Esq. of Oxton.  
General View of the Agriculture of the County of Nottingham. Lond. 4to.
1794. *Low, Alexander*, Esq. of Woodend, Berwickshire, an eminent land valuer and agent; he died about 1816.  
General View of the Agriculture of the County of Berwick. Lond. 4to.
1794. *Maunsell, William*, LL.D.  
Letter on the Culture of Potatoes from the Shoots. Lond. 8vo.
1794. *Leatham, Isaac*.  
General View of the Agriculture of the East Riding of Yorkshire. Lond. 4to.
1794. *Monk, John*, of Bear's Combe, near Kingsbridge, Devon.  
1. An Agricultural Dictionary; consisting of Extracts from the most celebrated Authors and Papers. Lond. 3 vols. 8vo.;  
2. General View of the Agriculture of the County of Leicester. Lond. 1794. 4to.
1794. *North, Roger*.  
History of Esulent Fish, and an Essay on the Breeding of Fish, and the Construction of Fish Ponds. Lond. 4to.
1794. *Drier, Abraham and William*, land surveyors and agents, London.  
General View of the Agriculture of the County of Hants. Lond. 4to.
1794. *Donaldson, James*, land surveyor and land steward for some extensive estates.  
1. General View of the Agriculture of the County of Nairn. Lond. 4to.  
2. General View of the Agriculture of Elgin and Moray.  
3. General Views of the Agriculture of the Counties of Perth, Banff, Northampton, and Mearns or Kincardine. Lond. 1794. 4to.  
4. Modern Agriculture; or the present State of Husbandry in Great Britain. Edin. 1795-6. 4 vols. 8vo.
1794. *Amos, William*, of Brothertoft, Lincolnshire, farmer.  
1. The Theory and Practice of Drill Husbandry, &c. Lond. 4to.  
2. Minutes of Agriculture and Planting, &c. Lond. 1804. 4to.
1794. *Davis, Richard*, of Lewknor, land surveyor and valuer.  
General View of the Agriculture of the County of Oxford. Lond. 4to.
1794. *Davis, Thomas*, Esq. steward to the Marquis of Bath at Longleat; a man of strong mind and great integrity, universally respected; he died about 1818.  
General View of the Agriculture of Wiltshire. Lond. 8vo.
1794. *Clark, John*, F.S.A. land surveyor, Builth; and at Pembroke.  
1. General View of the Agriculture of Brecknock. Lond. 4to.  
2. General View of the Agriculture of the County of Radnor. Lond. 1794. 4to.  
3. General View of the Agriculture of the County of Hereford. Lond. 1794. 4to.  
4. An Inquiry into the Nature and Value of Leasehold Property. Glouc. 8vo.
1794. *Hodgkinson, Joseph*.  
Instruction to Farmers on an Improved Method of Management of Arable Ground. Lond. 8vo.
1794. *Foot, Peter*.  
General View of the Agriculture of the County of Middlesex. Lond. 4to.
1794. *Fox, John*.  
1. General View of the Agriculture of the County of Monmouth. Brentf. 4to.  
2. General View of the Agriculture of the County of Glamorgan. Lond. 1796. 4to.
1794. *Pitt, William*, of Pendeford, near Wolverhampton.  
1. General View of the Agriculture of the County of Stafford. Lond. 8vo.  
2. A General View of the Agriculture of Northamptonshire. 8vo.
3. A General View of the Agriculture of Worcestershire. 1811.
1795. *Mariott, William*, barrister at law.  
The Country Gentleman's Lawyer, and the Farmer's Complete Library. 8vo.
1795. *Bonner, James*.  
Plan for speedily Increasing the Number of Bee Hives in Scotland. Lond. 8vo.
1795. *Holt, John*, of Watten, near Liverpool, was born in Cheshire 1742; died 1801.  
1. General View of the Agriculture of the County of Lancaster; with the Observations on the Means of its Improvement; drawn up for the Board of Agriculture. Lond. 8vo.  
2. An Essay on the Cult of Potatoes.
1795. *Eryskine, John Francis*, now Earl of Marr.  
General View of the Agriculture of the County of Clackmannan. Edin. 4to.
1795. *Robertson, the Rev. George*, minister of Dalmeny, near Edinburgh; died there in 1801.  
General View of the Agriculture of the County of Midlothian. Edin. 8vo.
1795. *Hayes, Samuel*, Esq. M.R.J.A. of Avondale, Ireland.  
A Practical Treatise on the Management of Woods and Coppices. Dub. 8vo.
1794. *Cochrane, Archibald*, Earl of Dundonald, an amateur chemist, and agriculturist.  
1. A Treatise shewing the Intimate Connection that subsists between Agriculture and Chemistry. Lond. 4to.  
2. The Principles of Chemistry applied to the Improvement of the Practice of Agriculture. 1799. 4to.
1795. *Macphail, James*, twenty years gardener to the Earl of Liverpool in Surrey, and author of *The Gardener's Remembrancer*, an esteemed work.  
Hints and Observations on the Improvement of Agriculture. Lond. 8vo.
1796. *Kirkpatrick, H.*  
An Account of the Manner in which Potatoes are cultivated and preserved, and the Uses to which they are applied in the Counties of Lancaster and Chester; together with a Description of a new Variety of Potatoes, peculiarly convenient for forcing in Hot-houses and Frames. Lond. 8vo.
1796. *Boys, John*, farmer at Bethshanger in Kent.  
A General View of the Agriculture of the County of Kent. Lond. 8vo.
1796. *Anstruther, Sir John*, Bart.  
Remarks on Drill Husbandry. Lond. 8vo.
1796. *Fox, William*, attorney at law.  
Remarks on various Agricultural Reports; transmitted to the Honorable the Board of Agriculture, in the Year 1794. Lond. 4to.
1796. *Wright, Sir James*, Bart.  
Observations upon the important Object of preserving Wheat and other Grain from Vermin. Lond. 4to.
1796. *Kirwan, Richard*, LL.D., F.R.S.L. and E., P.R.I.A., an eminent philosopher and various author; died about 1819.  
On the Manures most advantageously applicable to various Sorts of Soil, and the Causes of their Beneficial Influence in each particular Instance. Lond. 8vo.
1796. *Lawrence, John*, a veterinary surgeon.  
1. Philosophical and Practical Treatise on Horses. Lond. 8vo.  
2. The Sportsman, Farrier, and Shoeing Smith's New Guide, being the Substance of the Works of the late C. de St. Bel. 1796. 8vo.  
3. The Modern Land Steward. Lond. 1802. 8vo.  
4. A General Treatise on Cattle. Lond. 1805. 8vo.  
5. The Farmer's Pocket Calendar, 1808.  
6. The New Farmer's Calendar, 1809.  
7. History and Delineation of the Horse in all its varieties, with 15 engravings, by Scott. Lond. 1810.
1797. *Mortley, Christopher*.  
Practical Observations on Agriculture, Draining, &c. in two Letters, addressed to Sir John Sinclair. Lond. 4to.
1797. *Johnstone, John*, land surveyor and drainer at Edinburgh.  
An Account of the most approved mode of Draining Land, according to the System practised by the late Mr. Joseph Elkington. Edin. 4to.
1797. *Lawson, J.*  
Essay on the Use of mixed and compressed Cattle Fodder, particularly adapted for Horses and Cattle on Shipboard, in Camps, or in Garrisons, with useful Tables, &c. Lond. 8vo.
1797. *Dix, William Spier*.  
Remarks on a newly invented Patent Machine for clearing Grain from the Straw, instead of threshing it with the Flail. Lond. 4to.
1797. *Bailey, John*, Esq. originally a schoolmaster, afterwards steward to Lord Tankerville, a man of enlightened mind, various useful and elegant acquisitions, and sound practical agricultural knowledge. He was much respected by all who knew him.  
1. A General View of the Agriculture of the County of Northumberland, by J. Bailey and J. Cullley. Newcastle. 8vo.  
2. A General View of the Agriculture of Durham, &c. Lond. 1811. 8vo.  
3. General View of the Agriculture of the County of Cumberland, 8vo.
1798. *Smith, Rev. John*, D.D. minister of Kilbrandon, in Argyleshire, afterwards one of the ministers of Campbellton.

A General View of the Agriculture of the County of Argyle. Edin. 8vo.

1798. *Douglas, Robert*, D.D. Minister of Galashiels.

A General View of the Agriculture, of the Counties of Roxburgh and Selkirk. Edin. 8vo.

1798. *Billingsley, John*, Esq., of Ashwick Grove, near Shepton Mallett.

General View of the Agriculture of the County of Somerset. Bath. 8vo.

1798. *Tatham, William*.

1. Remarks on Inland Canals, the System of Interior Navigation, and various Uses of the Inclined Plane. Lond. 4to.  
2. The Political Economy of Inland Navigation, Irrigation, and Drainage; with Thoughts on the Multiplication of Commercial Resources, and on the Means of bettering the Condition of Mankind by Construction of Canals. 11 Plates. Lond. 1799. 4to.

3. Communication concerning the Agriculture and Commerce of America; containing Observations on the Commerce of Spain with her American Colonies in the Time of War. Written by a Spanish Gentleman, and now edited with sundry other Papers relating to the Spanish Interest. Lond. 1800. 8vo.

4. An Historical and Practical Essay on the Culture and Commerce of Tobacco. Lond. 1800. 8vo.

5. National Irrigation, or the various Methods of watering Meadows; affording Means to increase the Population, Wealth, and Revenue of the Kingdom, by an Agricultural, Commercial, and general Economy in the Use of Water. Lond. 1801. 8vo.

6. Auxiliary Remarks on an Essay on the comparative Advantages of Oxen for Tillage in competition with Horses. Lond. 1801. 8vo.

7. Two Reports on the Navigation of the River Thames. Lond. 1803. 8vo.

1798. *Middleton, John*, Esq., land surveyor, London.

1. A View of the Agriculture of Middlesex. Lond. 8vo.  
2. Observations on the various Kinds of Manure. (*Nicholson's Journal*, iii. 340.) 1799.

1799. *Parkinson, Richard*, of Doncaster, a farmer, traveller in America, and afterwards steward to Sir Joseph Banks, in Lincolnshire.

1. The Experienced Farmer. Lond. 2 vols. 8vo.  
2. A Tour in America, in 1798, 1799, and 1800; exhibiting a particular Account of the American System of Agriculture, with its recent Improvements. Lond. 1805. 2 vols. 8vo.

3. The English Practice of Farming, exemplified in the Management of a Farm in Ireland. Lond. 1806. 8vo.

4. Treatise on the Breeding and Management of Live Stock. Lond. 1809. 2 vols. 8vo.

5. General View of the Agriculture of Huntingdonshire. Lond. 1811. 8vo.

1799. *Brown, Robert*, Esq., farmer near Haddington, one of the projectors, and for many years editor, of the *Farmers' Magazine*; a man of vigorous intellect, energetic language, and an excellent bean and wheat farmer.

1. General View of the Agriculture of the West Riding of Yorkshire, surveyed by Messrs. Rennie, Brown, and Shirreff, in 1795. Lond. 8vo.

2. Treatise on Rural Affairs; originally published in the Edinburgh Encyclopedia. Lond. 1811. 2 vols. 8vo.

3. Letters on the Distressed State of Agriculturists. 1816.

1799. *Banister, John*, Gent. of Horton Kirby, in Kent.

-A Synopsis of Husbandry. Lond. 8vo.

1799. *Pallett, T.*, land and timber surveyor.

Hints on Enclosing, Agriculture, Stewardship, and Tithes. 8vo.

1799. *Somerville*, Right Hon. *John*, Lord. He died at Vevey in Switzerland, on his way to Italy about 1815; was buried in the churchyard there, and afterwards disinterred and brought to England.

1. Address to the Board of Agriculture on the Subject of Sheep and Wool. Lond. 8vo.

2. The System followed during the Two last Years by the Board of Agriculture, &c. 1800. 4to.

3. Facts and Observations relative to Sheep, Wool, Ploughs, and Oxen, &c. Lond. 1805. 8vo.

1799. *Robertson, James*, D.D. minister at Calandar, Perthshire.

1. General View of the Agriculture of the County of Perth. Perth. 8vo.

2. General View of the Agriculture of Inverness-shire. 8vo.

3. General View of the Agriculture of Kincardineshire. 1811. 8vo.

1800. *Owen, Rev. T.*, M.A. rector of Upton Scudamen, Wilts.

1. The Three Books of M. Terentius Varro, concerning Agriculture. Translated into English. Lond. 8vo.

2. Agricultural Pursuits. Translated from the Greek. Lond. 1805. 2 vols. 8vo.

3. Translation of the Fourteen Books of Palladius on Agriculture. Lond. 1807. 8vo.

1800. *Washington, Gen. George*, first president of the United States of America, and commander in chief of the armies, was born in the county of Virginia, 1732; died 1799.

1. Letters from him to Sir John Sinclair on Agricultural and other interesting Topics; engraved from the original Letters, so as to be an exact Fac-simile of the Handwriting of that celebrated Character. Lond. 4to.

2. Letters to Arthur Young, Esq., containing an Account of his Husbandry, with a Map of his Farm; his Opinions on various Questions in Agriculture, and many Particulars of the Rural Economy of the United States. Lond. 1801.

1800. *Tuke, John*, land surveyor.

General View of the Agriculture of the North Riding of Yorkshire. 15 Plates. Lond. 8vo.

1800. *Thomson, Rev. John*, D.D.

General View of the Agriculture of the County of Fife. Edin. 8vo.

1800. *Stacey, Rev. Henry Peter*, LL.B., F.L.S.

Observations on the Failure of Turnip Crops. Lond. 8vo.

1800. *Parry, Caleb Hillier*, M.D., F.R.S. physician, Bath. He cultivated his own estate, and greatly improved the merino-ryland breed of sheep.

Facts and Observations, tending to shew the Practicality and Advantage to the Individual and the Nation, of producing in the British Isles, Clothing-wool equal to that of Spain; together with some Hints towards the Management of fine-wooled Sheep. Lond. 8vo.

1800. *Dalrymple, William*, Esq.

Treatise on the Culture of Wheat. Lond. 8vo.

1800. *Darwin, Erasmus*, M.D., F.R.S., an eminent physician, philosopher, and poet, was born near Newark, in Nottinghamshire, 1731; died 1802.

Phytologia; or, the Philosophy of Agriculture and Gardening. Lond. 4to.

1800. *Ponsey, William*, nurseryman and forest pruner to the Duke of Bedford; originally a kitchen gardener, now a director of plantations, and other improvements.

1. The Profitable Planter. Huddersfield, 8vo.

2. The Forest Pruner; or, Timber Owner's Assistant. Lond. 1805. 8vo.

1801. *Hoyle, Henry*, land-surveyor.

An Essay on the Conversion of Soils. Lond. 4to.

1801. *Renton, George*, a farmer near Edinburgh. The Grazier's Ready Reckoner; or, a Useful Guide for buying and selling Cattle. 8vo.

1801. *Coote, Sir Charles*, Bart.

1. Statistical Survey of the County of Monaghan. Dublin. 8vo.

2. Statistical Survey of the County of Armagh. Dublin, 1804. 8vo.

1801. *Scott, Edmund*, miniature painter of Brighton-helmstone.

Proceedings of the Sussex Agricultural Society, from its Institution to 1798 inclusive; together with Engravings of the Prize Cattle for that Year, from Drawings made by actual Admeasurement. fol.

1801. *Scott, W.*, of the Inner Temple.

Every Farmer his own Lawyer, &c. 8vo.

1801. *Duncumb, John*, A.M., of Cambridge.

1. Essay on the best means of applying Pasture Lands, &c. to the production of Grain, and of re-converting them to Grass. Lond. 8vo.

2. Survey of the Agricultural and Rural Economy of Herefordshire. Lond. 1805. 8vo.

1801. *Archer*, Lieutenant *Joseph*.

Statistical Survey of the County of Dublin. Dub. 8vo.

1802. *McEvoy, John*.

Statistical Survey of the County of Tyrone. Dub. 8vo.

1802. *McParlan, James*, M.D.

1. Statistical Survey of the County of Donegal. Dub. 8vo.

2. Statistical Survey of the County of Leitrim. Dub. 1802.

8vo.

3. Statistical Survey of the County of Sligo. Dub. 1802.

8vo.

4. Statistical Survey of the County of Mayo. Dub. 1802.

8vo.

1802. *Thompson, Robert*.

Statistical Survey of the County of Meath.

1802. *Alderson, John*, M.D., physician at Hull.

On the Improvement of Poor Soils in Answer to the following Question: "What is the best Method of cultivating and improving Poor Soils, where Lime and Manure cannot be had?" Lond. 8vo.

1802. *Bartley, Nehemiah*, Esq., secretary to the Bath Agricultural Society.

Some cursory Observations on the Conversion of Pasture Lands into Tillage, and, after a certain Course of Crops, relaying the same into Pasture, &c. Lond. 8vo.

1802. *Sampson, Rev. G. Vaughan*, A.B., M.R.I.A., rector of Aghanloo, in the diocese of Derry.

Statistical Survey of the County of Londonderry. Dub. 8vo.

1802. *Dubourdieu, Rev. John*, rector of Annahilt.

Statistical Survey of the County of Down. Dub. 8vo.

Statistical Survey of the County of Antrim. Dub. 1812. 8vo.

1802. *Tighe, William*, Esq.

Statistical Observations relative to the County of Kilkenny. Dub. 8vo.

1802. *Bell, Benjamin*, F.R.S.E., surgeon, Edinburgh.

Essays on Agriculture. Edin. 8vo.

1802. *Findlater, Rev. Charles*, minister of the parish of Newlands, in the County of Peebles; a man of sound views of political agriculture.

General Survey of the Agriculture of the County of Peebles. Edin. 8vo.

1803. *Banks, Sir Joseph*, Bart., K.B., president of the Royal Society, F.R.S.E., F.A.S., M.R.I.A.

1. A Report of the State of His Majesty's Breed of Fine Woolled Spanish Sheep, for the Year ending Michaelmas, 1805. (*Nic. Jour.* vi. 277-1804.)

2. A Short Account of the Causes of the Diseases in Corn, called by Farmers the Blight, the Mildew, and the Rust, with Plates. Lond. 4to. 1805.

3. An attempt to ascertain the Time when the Potatoe

(*Solanum tuberosum*) was first introduced into the United Kingdom, with some Account of the Hill Wheat of India. (*Trans. Hort. Soc. l. 8. 1815.*)

1803. *Carpenter, J.*, Worcestershire. A Treatise on Practical and Experimental Agriculture. Stourbridge, 2 vols. 8vo.

1803. *Munnings, Rev. Thomas Crowe.* An Account of Experiments for Drilling and Protecting Turnips, in the years 1800, 1801, and 1802. Lond. 8vo.

1803. *Lester, William*, farmer in Lincolnshire, and afterwards a mechanist and engineer in London; inventor of a thrashing machine on the rubbing principle.

1. Observations on the Utility of Cutting Hay and Straw, and of Bruising Corn for Feeding Animals; with a Description of the best Machines for that Purpose. Lond. 8vo.

2. The Economy of the Barn; or, a Dialogue between a Farmer and an Economist, on the Separation and Preservation of Corn. Lond. 1811. 4to.

3. A History of British Inventions and Machinery applicable to Agriculture. Lond. 1811. 4to.

4. Description of a Machine for Washing Potatoes, and other Esculent Roots, for feeding Cattle. (*Nic. Jour. xxx. 356.*) 1811.

1804. *Greaves, William*, agriculturist, of Sheffield. Treatise on Natural and Practical Agriculture. Lond. 8vo.

1804. *Batchelor, Thomas*, farmer. General View of the Agriculture of Bedfordshire. 8vo.

1804. *Knapp, J. L., Esq., F.L. and A.S.S.* Gramina Britanica, or Representations of the British Grasses; with Remarks and occasional Descriptions. Lond. 4to.

1804. *Wisset, Robert, Esq.* A Treatise on Hemp. Lond. 8vo.

1804. *Dickson, R. W., M.D.*, of Hendon, Middlesex, author of various works. He died in London in penurious circumstances in 1824.

1. Practical Agriculture. Plates. Lond. 2 vols. 4to.

2. Agricultural Magazine; or Farmer's Monthly Journal of Husbandry and Rural Affairs, &c. From July 1807, to December 1808. 3 vols. 8vo. Discontinued.

3. The Farmer's Companion; being a complete System of Modern Husbandry. Lond. 1811. 4to.

4. An Improved System of Cattle Management. Lond. 1822. 2 vols. 4to.

1804. *Forsyth, Robert, Esq.*, advocate, Edinburgh, author of *Elements of Moral Science*, and other esteemed philosophical works.

Principles and Practice of Agriculture systematically explained being a Treatise compiled for the Fourth Edition of the Encyclopædia Britannica, revised and enlarged. 2 vols. 8vo.

1805. *Lucecock, John*, woolstapler at Leeds.

1. The Nature and Properties of Wool illustrated; with a Description of the English Fleece. Lond. 12mo.

2. An Essay on Wool; containing an Examination of the present Growth of Wool in every District throughout the Kingdom, and the Means pointed out for its Improvement. 1807.

1805. *Pearson, George, M.D., F.R.S.*, senior physician to St. George's Hospital, lecturer in chemistry, and on the theory and practice of medicine in London.

A Communication to the Board of Agriculture, on the Use of Green Vitriol, or Sulphat of Iron, as a Manure; and on the Efficacy of Paring and Burning depending partly on Oxide of Iron. Lond. 4to.

1805. *Somerville, Robert*, a surgeon in Haddington, and for some time joint editor with Brown of *Markle of The Farmer's Magazine*; he died in 1803.

General View of the Agriculture of East Lothian. Lond. 8vo.

1805. *Aiton, William*, sheriff-substitute for the middle ward of Lanarkshire, author of various papers in *The Farmer's Magazine*.

1. Essay on the Origin, Quantities, and Cultivation of Moss Earth. Glasg. 8vo.

2. General View of the Agriculture of the County of Ayr, with Observations on the Means of its Improvement. Glasg. 1811. 8vo.

3. General View of the County of Bute, &c. Glasg. 1816. 8vo.

1805. *Barber, William*, a London architect.

1. Farm Buildings; containing Designs for Cottages, Farmhouses, Lodges, Farm-yards, &c. Six Plates. Lond. 4to.

2. A Description of the Mode of Building in Pisé. 1806. 4to.

1805. *Hood, Thomas Sutton, Esq.* A Treatise on Gypsum; on its various Uses, and on its Application as a Manure. 8vo.

1805. *Malcolm, James*, land surveyor to the Prince of Wales, &c.

A Compendium of Modern Husbandry, &c. Lond. 3 vols. 8vo.

1806. *Smith, William*, engineer and mineralogist, a man of extraordinary exertion and merit, more especially as having been the first to compose a geological map of England, and also most valuable county geological maps.

1. The Improvement of Boggy Land by Irrigation, as carried into effect by him. Lond. 8vo.

2. Observations on the Utility, Form, and Management of Water Meadows, and the Drainage and Irrigating Vent-holes; with an Account of Pringle Bog, and other extraordinary Improvements conducted for the Duke of Bedford. Lond. 1809. 8vo.

3. Geological Map of England and Wales and part of Scotland. 1815.

4. Geological Table of British organized Fossils. 1819.

5. County Geological Maps. 1819.

1806. *Ainslie, John*, a land surveyor at Edinburgh.

1. Tables for computing the Weight of Hay, Cattle, &c., by Measurement. Lond. 12mo.

2. Farmer's Pocket Companion. Edin. 1812. 8vo.

1807. *Vancouver, Charles*, land valuer.

1. A General View of the Agriculture of the County of Devon. Lond. 8vo.

2. General View of the Agriculture of Hampshire, including the Isle of Wight. 1811. 8vo.

1807. *Rudge, Rev. Thomas, B.D.*

Survey of the Agriculture of the County of Gloucester. Lond. 8vo.

1807. *Hogg, James*, the Ettrick Shepherd, author of some poetical pieces, and Scotch novels.

—The Shepherd's Guide. Edin. 8vo.

1807. *Holland, Henry, Esq., M.D.*, honorary member of the Geological Society. Author of *Travels in Greece*, and other works; an eminent London physician.

General View of the Agriculture of Cheshire. Lond. 8vo.

1807. *Lawson, Thomas James, Esq.*

Statistical Survey of the County of Kidare. Dublin, 8vo.

1807. *Headrick, James*, a clergyman in Anguishire, an excellent chemist, and agricultural philosopher.

1. View of the Mineralogy, Agriculture, Manufactures, and Fisheries of the Island of Arran, &c. Edin. 8vo.

2. General View of the Agriculture of the County of Angus. 1815. 8vo.

1808. *Tibbs, Thomas*, farmer.

The Experimental Farmer. 8vo.

1808. *Coventry, Andrew, M.D.* professor of agriculture in the university of Edinburgh. A learned, ingenious, and most benevolent man. He cultivates his own estate in Kinross-shire, and is extensively employed as a land valuer, and rural counsellor.

1. Discourse Explanatory of the Nature and Plan of a Course of Lectures on Agriculture and Rural Economy. Edin. 8vo.

2. Observations on Live Stock, in a Letter to Henry Clive, Esq. Edin. 8vo.

1808. *Gray, Andrew*, a retired machinist at Edinburgh.

Plough-wright's Assistant; or, a Practical Treatise on various Implements employed in Agriculture; illustrated with 16 Engravings. Edin. 8vo.

1808. *Beddoes, Thomas, M.D.*, born in Shropshire, 1760, was lecturer in Botany at Oxford, and afterwards physician at Bristol, where he died, 1808.

1. Good Advice for the Husbandman in Harvest, and for all those in Labour in Hot Births; as also for others who will take it in Warm Weather. 8vo.

2. On the Means of fortelling the Character of the Summer Season, and the Benefits to be expected from the Cultivation of Grasses which vegetate at low temperatures. (*Nic. Jour. v. 151.*) 1802.

1808. *Bakewell, Robert, Esq.*, an eminent geologist and mineralogist, author of *Travels in the Tarentaise, &c.*, an instructive and entertaining work, published in 1823.

Observations on the Influence of Soil and Climate upon Wool, with an easy Method of improving the Quality of English Clothing Wool, and Hints for the Management of Sheep, &c.; with occasional Notes and Remarks by the Right Hon. Lord Somerville. Lond. 8vo.

1808. *Dutton, Hetty, Esq.* landscape gardener.

1. Statistical Survey of the County of Clare. Dublin, 8vo.

2. Statistical Survey of the County of Galway. Dublin, 1824. 8vo.

1809. *Curwen, John Christian, M.P.* of Workington Hall, Cumberland, a great agricultural patriot, father of the soiling and steaming systems in England, and an excellent man.

1. Hints on the Economy of Feeding Stock, and bettering the Condition of the Poor. Lond. 8vo.

2. A Tour in Ireland. 2 vols. 8vo. 1819.

1809. *Stevenson, W. Esq., M.A.* librarian to the treasury, author of various works, and a writer in the principal encyclopædias.

General View of the Agriculture of the County of Surrey. Lond. 8vo.

1809. *Mackenzie, Sir George Stewart*, Bart. F.R.S.S. L. and E.

A Treatise on the Diseases and Management of Sheep. Lond. 8vo.

1809. *Price, John*, grazier, of Romney Marsh.

A Treatise on the Breeding and Management of Sheep. 4to.

1809. *Greg, Thomas, Esq.* an amateur cultivator in Hertfordshire.

1. Letter to the Board of Agriculture on Ploughing heavy and wet Land. Lond. 8vo.

2. Report of his System of Farming. 1811. 8vo.

1809. *Kerr, Robert*, surgeon, F.R. and A.S.S. Edinburgh, an excellent naturalist and general scholar; died 1814.

Statistical, Agricultural, and Political Survey of Berwickshire. 8vo.

1810. *Davies, Walter, A.M.*

A General View of the Agriculture and Domestic Economy of North Wales. Lond. 8vo.

1810. *Hunt, Charles Henry, Esq.*  
Treatise on the Merino and Anglo-Merino Breeds of Sheep. Lond. 8vo.
1810. *Townsend, Rev. Horatio, M.A.* rector and vicar of the union of Kilgariff, in the diocese of Ross, and of Carigaline in the diocese of Cork. Statistical Survey of the County of Cork. Dublin, 8vo.
1810. *Williamson, Capt. Thomas*, upwards of 20 years in Bengal.  
Agricultural Mechanism; or, a Display of the several Properties and Powers of the Vehicles, Implements, and Machinery connected with Husbandry. Lond. 8vo.
1810. *Adams, George.*  
A New System of Agriculture and Feeding Stock. Lond. 8vo.
1810. *Drury, Charles*, of Nottingham, apparently a sort of charlatan agriculturist.
1. A Farmer's recent and important Discovery of a System for Improving Land and augmenting Crops of Corn, &c. Lond. 8vo.
2. Recent and important National Discoveries. Lond. 1813. 8vo.
1810. *Farish, John, Dumfries.*  
A Treatise on Florin Grass. 8vo.
1810. *Edgeworth, Richard Lovell, Esq. F.R.S.* and *M.R.I.A.*, civil engineer, resident at Edgeworth Town, Ireland, author of various works.  
An Essay on the Construction of Roads and Carriages. Lond. 8vo.
1811. *Morley, John*, of Blickling, in the county of Norfolk.  
Cheap and profitable Manure. Lond. 8vo.
1811. *Lee, H. P. Esq.*, Maidenhead Thicket.  
Description of a New Threshing Machine invented by him. (*Nicholson's Journal*, xxix. 274.)
1811. *Livingston, Chancellor.*  
An Essay on Sheep; with additional Remarks, by William Cobbett. Lond. 8vo.
1811. *Macdonald, James, M.A.*  
General View of the Agriculture of the Hebrides. 8vo.
1811. *Morgan, J. R.*, farmer and land surveyor.  
General View of the Agriculture of the County of Cornwall. Lond. 8vo.
1811. *White, Rev. Andrew, and Duncan Macfarlan, D.D.*  
General View of the Agriculture of Dumbartonshire. Glasg. 8vo.
1811. *Keith, George Skeene, D.D.*  
A General View of the Agriculture of Aberdeenshire. 8vo.
1811. *Smith, Rev. Samuel.*  
General View of the Agriculture of Galloway. Lond. 8vo.
1811. *Henderson, Robert*, farmer at Broomhill, near Annan, Dumfriesshire.  
Treatise on the breeding of Swine and curing of Bacon; with Hints on Agricultural Subjects. Edin. 8vo.
1811. *Farey, John, sen.*, mineral surveyor. A man of sound views and great experience.  
General View of the Agriculture and Minerals of Derbyshire. Lond. 3 vols.
1811. *Loudon, John, F.L.S., H.S.*, landscape gardener, author of the *Encyclopædia of Gardening*, and other works; born in Lanarkshire in 1782, began to practise in 1803; to farm extensively in Oxfordshire in 1809, and in Middlesex in 1810; travelling on the continent in 1813-14-15, again in 1819, now residing at Bayswater.  
Designs for laying out Farms and Farm Buildings in the Scotch Style, adapted to England; comprising an Account of the Introduction of the Berwickshire Husbandry into Middlesex and Oxfordshire. Lond. 4to.
1811. *Gooch, Rev. W.*  
General View of the Agriculture of Cambridgeshire. Lond. 8vo.
1812. *Trotter, James*, farmer.  
General View of the Agriculture of West Lothian. 8vo.
1812. *Bald, Robert*, civil engineer at Alloa.  
General View of the Agriculture of the County of Mid-Lothian. 8vo.
1812. *Strickland, H., Esq.*, of Brighton.  
A General View of the Agriculture of the East Riding of Yorkshire. Lond. 8vo.
1812. *Singer, Rev. William, D.D.*, minister of Kirkpatrick.  
General View of the Agriculture, State of Property, and Improvements in the County of Dumfries. Edin. 8vo.
1812. *Henderson, J.*  
General View of the Agriculture of the County of Caithness. 8vo.
1813. *Walker, W.*  
An Essay on Draining Land by the Steam Engine. Lond. 8vo.
1813. *Davy, Sir Humphrey*, president of the Royal Society, LL.D., V.P.R.I., F.R.S., Edin. M.R.I.A., &c.  
Elements of Agricultural Chemistry; in a Course of Lectures for the Board of Agriculture. 4to. and 8vo.
1813. *Horner, T., Esq.*, land surveyor, a man of great genius and ability in various departments of drawing and pictorial description.  
Description of an Improved Method of delineating Estates. Lond. 8vo.
1813. *Newby, Thomas.*  
Remarks on the Mangel-Wurzel (Mangold Wurzel), or Root of Scarcity, with Directions for its Culture. Lond. 8vo.
1814. *Johnson, John*  
Short Essay on Agricultural Improvements; shewing, as the first Object, the great need thereof. 8vo.
1814. *Shirreff, John*, farmer at Captain Head, near Haddington, Scotland, afterwards a land agent, and finally steward to a nobleman near Stirling.
1. General View of the Agriculture of the Orkney Islands. Edin. 8vo.
2. Method of Stacking Turnips to preserve them through the Winter. (*Nicholson's Journal*, xlii. 268.)
1815. *Huish, Robert, Esq.*, of the Imperial Apian Society at Vienna.  
A Treatise on the Nature, Economy, and Practical Management of Bees. Lond. 8vo.
1815. *Dodd, Ralph*, civil engineer.  
Practical Observations on the Dry Rot in Timber. Lond. 8vo.
1815. *Moubray, Bonnington, Esq.*  
A Practical Treatise on the method of Breeding, Rearing, and Fattening Domestic Poultry, Pigeons, and Rabbits. 8vo.
1815. *Little, John.*  
Practical Observations on the Improvement and Management of Mountain Sheep and Sheep Farms. 8vo.
1815. *Simpson, Pindar.*  
Treatise on the Cultivation of Mangold Wurzel, as Winter Food for Cattle. Lond. 8vo.
1815. *Birbeck, Morris, Esq.*, formerly a farmer in Suffolk, now an extensive proprietor and resident cultivator in the Illinois. Drowned there in 1825.
1. Notes in a Journey through France from Dieppe, through Paris and Lyons to the Pyrenæes, and back through Toulouse in 1814, describing the Habits of the People, and the Agriculture of the County. 8vo.
2. Notes in a Journey in America, from the Coast of Virginia to the Territory of Illinois. Lond. 1818. 8vo.
1815. *Hornby, Thomas, Esq.*, surgeon, York.  
Dissertation on Lime, and its use and abuse in Agriculture, embracing a View of its Chemical Effects. 8vo.
1816. *Vanderstræten, T.*  
Improved Agriculture, and the Suppression of Smuggling, Property Tax, and Poor's Rates, &c. Lond. 8vo.
1816. *Anderson, William*, farmer, Angusshire.  
Observations on a new Mode of Stacking Corn, peculiarly adapted to Wet Seasons; recommending a Plan, successfully practised, by which corn may be stacked with advantage soon after being cut down. 8vo.
1818. *Macwilliam, Robert, Esq.* architect and surveyor, London.  
An Essay on the Origin and Operation of the Dry Rot; to which are annexed, Suggestions for the Cultivation of Forest Trees, and an Abstract of the Forest Laws. 4to.
1819. *Radcliffe, Rev. T.*  
A Survey of the Husbandry of Eastern and Western Flanders, made under the Authority of the Dublin Farming Society. 8vo.
1819. *Williams, T. W.*  
The Farmer's Lawyer; containing the Whole of the Law and local Customs in regard to Agricultural Possessions, Properties, and Pursuits. 8vo.
1819. *Swinburne, R.*  
The Farmer's New and Complete Account Book.
1819. *Blackie, Francis*, first gardener, and afterwards steward to T. W. Coke, Esq. of Holkham.
1. A Treatise on the Management of Hedge and Hedge-row Timber. 12mo.
2. On the Economy of Farm Yard Manure, &c. 12mo. 1820.
3. On Mildew, and the Culture of Wheat. 12mo. 1821.
4. On Smut in Wheat. 12mo. 1822.
1820. *Hibby, Edward, M.D.*, F.L.S.
1. Framlingham, its Agriculture, &c., including the Economy of a small Farm. 8vo.
2. Holkham, its Agriculture, &c. 8vo. 1821.
1820. *Grisenthwaite, William*, apothecary, of Wells, in Norfolk.  
A new Theory of Agriculture, in which the Nature of Soils, Crops, and Manures is explained, many prevailing prejudices are exploded, and the Application of Bones, Gypsum, Lime, Chalk, &c. determined on scientific Principles. 12mo.
1820. *Beatson, Major-General Alexander*, formerly governor of St. Helena.  
A Description of a new Agricultural Implement; which, by the Power of One Horse, performs a Variety of Operations in Cultivation, at the Rate of Three Acres per Day. 8vo.
1820. *Mather, John*, Castle Hill, Carse of Gowrie.  
The Farmer and Land Steward's Assistant; or, a Specimen of Farm Book-keeping, exhibiting in a concise and simple Form, the Transactions in the arable, grazing, and woodland Departments; a general Cash Account; and an Account of the Charge and Discharge upon each Department; the Whole selected from Books of real Business. 4to.
1820. *Johnson, Cuthbert William.*  
An Essay on the Uses of Salt for Agricultural Purposes, with Instructions for its Employment as a Manure, and in the Feeding of Cattle, &c.
1820. *Towne, L.*  
The Farmer and Grazier's Guide. 8vo.
1820. *Burroughs, Edward, Esq.*  
Essays on Practical Husbandry and Rural Economy. 8vo.
1822. *Sallsbury, W.* formerly a botanical nurseryman, now a private teacher of botany, &c.  
The Cottager's Agricultural Companion, 12mo.
1822. *Munro, Colonel Innes.*  
A Guide to Farm Book-keeping, founded upon actual Practice, and upon new and concise Principles. Royal 8vo.
1822. *Napier, Hon. William John*, F.R.S. Edin. post captain in the Royal Navy; a vice-president of the Pastoral Society of Selkirkshire, &c.

A Treatise on Practical Store Farming, as applicable to the Mountainous Region of Ettrick Forest, and the Pastoral District of Scotland in general. With Engravings. 8vo.

1822. *Donald, R.*  
A New System of National and Practical Agriculture; with Hints for improving Estates. Lond. 8vo.

1822. *Cleghorn, James, Esq.* formerly a practical farmer, now editor of *The Farmer's Magazine*, author of the article "Agriculture" in the supplement to the *Encyc. Brit.*, and of various articles in that work. One of the best modern writers on agriculture.

On the depressed State of Agriculture. Edin. 8vo.

1823. *Fairburn, John.*  
A Treatise upon Breeding, Rearing, and Feeding Cheviot, and Black Faced Sheep in high Districts; with Observations on laying out and conducting a Store Farm, &c. Edin. 8vo.

1823. *Low, David, Esq.*  
Observations on the present State of Landed Property, and on the Prospects of the Landholder, and the Farmer. Edin. 8vo.

1824. *Morice, Francis.*  
An Essay on Agriculture, and the Management of Landed Estates. Lond. 8vo.

1824. *Sinclair, George, F.L.S., F.H.S.* formerly gardener to the Duke of Bedford, at Woburn, now of the firm of Cormack, Son, and Sinclair, nurserymen, New Cross, Deptford.

*Hortus Gramineus Woburnensis*; or, an Account of the Results of various Experiments on the Produce and Fattening Properties of different Grasses, and other Plants used as the Food of the more valuable domestic Animals; instituted by John Duke of Bedford. To which is added, an Appendix, pointing out the different Grasses best adapted for the Manufacture of Leghorn Bonnets, &c. Lond. Royal 8vo.

1824. *Western, C. C. Esq. M.P.*  
Practical Remarks on the Management and Improvement of Grass Land, as far as relates to Irrigation, Winter-flooding, and Drainage; in a Letter to the Land Owners, &c. of the County of Essex. Lond. 8vo.

1824. *Slaney, Robert N. Esq., barrister.*  
Essay on the beneficial Direction of Rural Expenditure. Lond. 12mo.

SECT. II. *Bibliography of Agriculture in Foreign Countries.*

7111. Numerous works on agriculture are published in the French and German languages, and a considerable number in the Italian; but a much greater proportion of these are translations from British authors than original works. Very few agricultural books have been printed in the Dutch, Flemish, Danish, Swedish, Polish, Spanish, or Portuguese languages, and scarcely any in those of Russia or Hungary. We shall notice the principal French, German, and Italian works, exclusive of translations, and add a few American books.

SUBSECT. 1. *Bibliography of French Agriculture.*

7112. Of French books on agriculture we have given a selection only; those who wish to see a complete list are referred to the *Bibliographie Agronomique*, Paris, 8vo.; in which are given the titles of upwards of 2000 works, including translations and books on gardening. A general idea of French culture in all its branches may be obtained from the *Nouveau Cours Complet d'Agriculture*, 16 vols. 8vo., (edition of 1821.) compiled by the members of the Section of Agriculture of the French Institute, each of whose names are given to the articles he contributed.

1529. *Etienné, Charles, et J. Liebaull*, physicians. *Etienné, i.e. Stephanus* or *Stephens*, in the beginning of the sixteenth century published various small tracts on Gardening and other rural topics; and in 1529 he collected them together and published them under the title of *Prædium Rusticum*, treating of gardens, trees, vines, fields, meadows, lakes, forests, orchards, &c. Having married his daughter to Liebaull, & a physician, they afterwards studied agriculture conjointly, and published the *Maison Rustique*, the modern editions of which are still the most popular agricultural works in France.

1. *Prædium Rusticum*, in fol.

2. *L'Agriculture et Maison Rustique*. Paris, in 4to. 1570.

1569. *Hesson Jacques*, of Dauphiny.  
De l'Art et Science de trouver sùrement les Eaux, Sources et Fontaines cachées sous Terre, autrement que par les Moyens Vulgaires des Agriculteurs et Architectes, in 4to.

1583. *Hegemon, Philibert*, a lawyer born at Châlons-sur-soane. Died in 1595.

La Colombière et Maison Rustique, contenant une Description des Douze Mois et des Quatre Saisons de l'Année, avec Enseignement de ce que le Laboureur doit faire par chaque Mois. Paris, in 8vo.

1602. *Letellier*.  
Brief Discours contenant la Manière de nourrir les Vers à Soie, &c. Avec de Belles Figures. Paris, in 4to.

1604. *Laffenans, Barthelemy de*, valet de chambre to Louis XIII.

La Façon de faire et semer la Graine de Mûriers, les élever et replanter, gouverner les Vers à Soie au Climat de France. Paris, in 12mo.

1607. *Vinct, Elic*, a learned professor at Bourdeaux, author of a work on land surveying.

La Maison Champêtre et Agriculture. Paris, in 4to.

1663. *Patin, Charles*, son of a physician of that name.

Traité des Tourbes Combustibles. Paris, in 4to.

1703. *Liger, Louis*, born 1653, died in 1717. In the latter part of his life he seems to have been a bookseller, or an author by profession.

1. *Dictionnaire Général des Termes propres à l'Agriculture*, avec leurs Définitions et Etymologies. Paris, in 12mo.

2. *La Nouvelle Maison rustique*, ou *Economie Générale des Biens de la Campagne*. Paris, 2 vols. in 4to. 1755.

3. *L'Economie Générale de la Campagne*, ou *Nouvelle Maison rustique*. 1762.

4. *Nouveau Système d'Agriculture*. 3 vols. in 8vo. 1775.

1749. *Boucher, d'Argis, Antoine Gaspard*, advocate and author of some works on jurisprudence.

Code Rural, ou *Maximes et Réglemens concernant les Biens de la Campagne*, 2 vols.

1749. *Réaumur, René, Antoine Ferchault, sieur de*,

a learned naturalist, born at Rochelle in 1683, died in 1757.

*Art et Pratique de l'Art de faire éclore, en toutes Saisons, des Oiseaux Domestiques de toutes espèces*. Paris, Imprim. Royale, 3 vols. in 12mo. avec fig.

1750. *Hamel, Du Monceau, Henry Lewis du*, a famous French writer on Rural Economy and Vegetable Physiology, was born at Paris, 1700; died there 1782.

1. *Traité de la Culture des Terres*. Par. 6 vols. 12mo.

2. *Elemens d'Agriculture*. Par. 1764. 2 vols. 12mo.

3. *Traité de la Conservation des Grains, et en Particulier du Froment*. Par. 1754. 12mo.

4. *Traité des Arbres et Arbustes, qui se cultivent en France, en plaine terre*. Par. 1755, 2 vols. 4to.

5. *Traité complet des Bois et des Forêts* Par. 1758, 6 tom. 4to.

6. *Des Semis et Plantations des Arbres, et de leur Culture*. Par. 1760. 4to.

7. *Histoire d'un Insecte qui devore les Grains de l'Angoumois*. Par. 1762. 12mo.

8. *De l'Exploitation des Bois, ou Moyen de tirer parti des Taillis demi Fufayes et hautes Fufayes*. Par. 1764. 2 vols. 4to.

9. *Mémoire sur la Garence et sa Culture*, in 4to. 1765.

10. *De Transport, de la Conservation, et de la Force du Bois* 1767. 4to.

1751. *Desbois, Francis Alexander Aubert de la Chesnaie*, a laborious Dictionary-maker; was born at Erné in the Maine, 1699; died 1784.

*Dictionnaire d'Agriculture*. 6 vols. 8vo.

1755. *Blauet*, librarian to the Prince of Conti.

*Essai sur l'Agriculture Moderne*. Paris, in 12mo.

1755. *Tillet, du, of Bourdeaux*, a zealous agriculturist, author of several works. He died in 1791.

*Dissertation sur la Cause qui corrompt et noircit les Grains de Blé dans les épis*, in 4to.

1753. *Hoséris, F. W.*

*Instruction sur la Manière d'élever et de Perfectionner les Bêtes à Laine*. Paris, 2 vols. in 12mo.

1760. *Alletz, Pons Augustin*, an advocate, and indefatigable compiler.

*L'Agronome, ou Dictionnaire portatif du Cultivateur*. 2 vols. in 8vo.

1760. *Buch'oz, Pierre Joseph*, a physician, and member of several societies; born at Metz in 1731, died in great distress at Paris in 1807. He wrote above three hundred volumes relative to medicine, agriculture, the veterinary art, and natural history. A plant (*Buchoziana*) was named after him by L'Héritier.

1. *Lettre sur la Méthode de s'enrichir promptement et de conserver sa Santé par la Culture des Végétaux*, in 8vo.

2. *Lettre sur le Bled de Smyrne*, in 8vo. 1768.

3. *Histoire des Insectes nuisibles à l'Homme, aux Bestiaux, &c.* in 12mo. 1751.

4. Manuel usuel et économique des Plantes, contenant leur Propriétés pour les Usages économiques. Paris, in 12mo. 1782.
5. Histoire des Insectes utiles à l'Homme, aux Animaux et aux Arts. Paris, in 12mo. 1785.
6. Traité de la Pêche, ou l'Art de soumettre les Poissons à l'Empire des Hommes, précédé de l'Histoire Naturelle de ces Animaux, in 12mo. 1786.
7. Dissertation sur la Bétiverie et la Polée, leur Culture, Méthode pour en tirer du Sucre, &c. fol. 1787.
8. Dissertation sur le Cochon, in fol. 1789.
9. Dissertation sur le Lin de Sibirie, in fol. 1789.
10. Dissertation sur la Taupé; les Moyens de la prendre, in fol. 1790.
11. Dissertation sur le Tirage de la Soie, in fol. 1792.
12. Manuel Tabacal et Steruatoire des plantes, ou Traité des Plantes qui sont propres à faire éternuer, avec la Manière de cultiver le Tabac, de le préparer, et de juger de ses bons Effets dans la Société, in 8vo. 1799.
13. Manuel Territorial des Plantes, in 8vo. 1799.
14. Manuel Vétérinaire des Plantes, in 8vo. 1799.
15. Mémoire sur le Blé de Smyre, sur le Blé de Turquie, le Millet d'Inde, et la Potherie d' Abyssinie, Plantes Alimentaires pour l'Homme; in 8vo. 1824.
16. Mémoire sur la Manière de former des Pralries Naturelles, in 8vo. 1805.

1760. *Turbilly, Louis-François-Henri de Menon*, Marquis de, a proprietor in Anjou, who had been in the army, but who retired to his estates and broke up and improved a number of acres, of which he published an account, well known at that time in England. Arthur Young, when in France in 1787, was anxious to visit the Marquis; but after, with difficulty, finding out the estate of Turbilly, he found the Marquis had died in 1776, having ruined himself by establishing a pottery. There is a very interesting account of this visit in *Young's Tour*, part I. p. 294, & seq.

1. Mémoire sur les Défrichemens. in 12mo.
2. Pratique des Défrichemens. Paris, in 12mo. 1701.
1761. *Guillot, Julien-Jean-Jacques*. Discours sur les Branches d'Agriculture les plus avantageuses à la Province de Normandie.
1761. *Neuve-Eglise, Louis-Joseph Bellepiere de*, An officer in the army.

1. L'Agronomie, ou Corps complet des Principes de l'Agriculture, &c. 8 vols. in 8vo.
2. Boussole Agronomique, ou le Guide des Laboureurs, in 8vo. 1762.

1762. *Desplaces, Laurent-Benoist*. Préservatif contre l'Agronomie, ou l'Agriculture réduite à ses vrais Principes. Paris, in 12mo.
2. Histoire de l'Agriculture ancienne, extrait de l'Histoire Naturelle de Pline, avec des Eclaircissemens et des Remarques. 12mo. 1765.

1762. *Despommiers*. L'Art de s'enrichir promptement par l'Agriculture. Paris, 12mo.
1762. *Lafaille, Clement*, advocate, and member of several societies.

1. Mémoire sur les Moyens de multiplier aisément les Fumiers dans le Pays d'Anis.
2. Essai sur l'Histoire naturelle de la Taupé; sur les différents Moyens qu'on peut employer pour la détruire. La Rochelle, in 12mo. fig. 1768.

1762. *L'Etang-de-la-Salle, Simon-Philibert de*, of Rheims, a lawyer.
- Des Prairies artificielles, ou Moyens de perfectionner l'Agriculture dans toutes les Provinces de France, surtout en Champagne, par l'entretien et le renouvellement de l'Engrais avec un Traité sur la Culture de la Luzerne, du Trèfle, et du Sainfoin, et une Dissertation sur l'Exportation du Blé. Paris. 8vo.

1763. *Barthez de Marmorières*, an officer, secretary of embassy, and member of various societies. Mémoires d'Agriculture, &c. 8vo.

1763. *Duvergé*, a physician of Tours. Analyse chimique des Terres de la Province de Touraine, des différents Engrais propres à les améliorer, et des Semences convenables à chaque espèce de Terre. Paris, 8vo.

1763. *François, Nicholas*, de Neuchâteau, member of the Institute, the Senate, &c., a distinguished member of the Paris Agricultural Society, and author of numerous papers in their memoirs.

1. Avis aux Cultivateurs et Propriétaires de Troupeaux, sur l'Amélioration des Laines. Paris. 8vo. an vii.
2. Essai sur les Moyens de tirer le parti le plus avantageux de l'Exploitation d'un Domaine borné, ou Système d'Agriculture pour les petits Propriétaires. Neuchâteau. 8vo. 1790.

3. Essai sur la nécessité et les Moyens de faire entrer dans l'Instruction publique l'Enseignement de l'Agriculture; lu à la Société d'Agriculture de la Seine, &c. 8vo. 1802.

4. Rapport sur le Perfectionnement des Charrues, fait à la Société Libre d'Agriculture du Département de la Seine. Paris. 8vo.

5. Répertoire universel et raisonné d'Agriculture. Paris. 12mo. 1804.

1763. *Préfontaine*. Maison Rustique à l'Usage des Habitans de la partie de la France équinoxiale, connue sous le Nom de Cayenne. 8vo.

1763. *Thierat*. An officer of the royal forests, author of some tracts on gardening.

- Instructions familières en forme d'Entretien sur les principaux Objets qui concernent la Culture des Terres. Paris. 12mo.

1764. *Bertraud, Elie*, a clergyman at Orbe, in Switzerland, and member of various societies.

1. Traité de l'Irrigation des prés. 12mo.
2. Elémens d'Agriculture, fondés sur les Faits et les raisonnemens, à l'Usage du Peuple de la Campagne. 8vo. 1774.

1764. *Bertrand, Jean*, brother of Elie B. De l'Eau relativement à l'Economie Rustique, ou Traité de l'Irrigation des prés. Lyons, 12mo.

1764. *Dupon, de Vemouns*, formerly a member of the constituent assembly.

1. Lettre sur la Différence qui se trouve entre la Grande et la Petite Culture. Soissons, 8vo.
2. Journal d'Agriculture, &c. 8vo. 1766.

1765. *Chambray, Louis*, Marquis de, an amateur apple grower and cyderist.

- L'Art de Cultiver les Pommiers, les Poiriers et de faire les Cidres, selon l'Usage de Normandie. Paris, 12mo.

1765. *Sarcey-de-Sutieres*, an officer in the army, and "gentilhomme servant" of the king.

1. Agriculture expérimentale à l'Usage des Agriculteurs, Fermiers, et Laboureurs. Paris, 12mo.

2. Cours complet d'Agriculture, ou Leçons périodiques sur cet Art. 1788.

1768. *Lesbros-de-la-Versane, Louis*, of Marseilles. Traité de la Garance, ou Recherches sur tout ce qui a Rapport à cette Plante. 8vo.

1768. *Marchand, Jean-Henri*. Les Délassemens Champêtres. 2 vols. 12mo.

1768. *Patteau, Guillaume-Louis Formanoir de*, of Sens, author of a work on bees. Observations et Expériences sur diverses Parties de l'Agriculture. Sens. 8vo.

1769. *Chanvallon*, a clergyman. Manuel des Champs ou Recueil choisi, instructif et amusant de tout ce qui est le plus Utile et le plus Nécessaire pour vivre avec Aisance et Agrément à la Campagne. Paris. 12mo.

1769. *De Breze*. Essai sur le Haras, ou Examen des Moyens propres pour établir, diriger et faire prospérer les Haras: suivi d'une Méthode facile de bien Examiner les Chevaux que l'on veut acheter. 8vo. fig.

1769. *Rigaud de l'Isle*, of Crest, in Dauphiny. Mémoire sur la Culture de l'Espargette, ou Sainfoin. Paris. 8vo.

1769. *Sieue*.

1. Mémoire et Journal d'Observations sur les Moyens de garantir les Olives de la piqûre des Insectes, et nouvelle Méthode pour en extraire l'Huile plus abondante par l'Invention d'un Moulin domestique, avec la Manière de la garantir de toute Rancissure. Paris, 12mo.
2. Mémoires sur diverses Constructions en Terre ou Argile, propres à faire jouir les petits Ménages de l'Economie des combustibles. Poitiers, 8vo. 1804.

1770. *Amiot, Le P.* missionary at Pekin.

- Reflexions sur l'Agriculture et sur ceux qui s'y consacrent, tirées de l'Éloge de la Ville de Moukden et de ses Environs: Poème composé par Kien-Long, Empereur de la Chine et de la Tartarie, actuellement régnant, traduit in François par le P. Amiot, et publié par M. Desnoignes, Membre de l'Académie Royale des Inscriptions et Belles Lettres, et Professeur des Langues Orientales au Collège Royal. Paris, 8vo. Cet Ouvrage est curieux sous plus d'un rapport.

1770. *Beaumé, Anthony*, an eminent French chemist, was born at Senlis, 1728; died 1805.

- Mémoire sur les Argiles, ou, Recherches sur la Nature de Terres les plus propres à l'Agriculture, et sur les Moyens de fertiliser celles qui sont Steriles. Paris, 8vo.

1770. *Riem*. Encyclopédie Economique, ou Système général d'Economie rustique, contenant les meilleures Pratiques pour fertiliser les Terres, la conservation des Grains, &c., par quelques Membres de la Société d'Agriculture de Berne. Yverdon, 16 vols. 8vo.

1772. *Rozier, François*, born in Lyons, in 1734, and killed there on the 29th September 1793, during the siege of that city, by a bombshell, which buried his shattered remains in the ruins of the apartment which he occupied; he began his career as an author by writing in the *Journal de Physique et d'Histoire Naturelle*, of which Gauthier Dagoty was editor. He next occupied himself with his *agricultural or rural dictionary*, the work by which he is chiefly known. He cultivated a farm near Beziers, which Arthur Young went to see when on his tour in France in 1787; but the Abbé had left it on account of the Bishop of Beziers, who kept a mistress somewhere near, and for his more commodiously visiting her, got a road made across the farm at the expence of the province. This occasioned a quarrel between the Abbé and the Bishop, which ended in the former being obliged to quit his farm. The Abbé, like all other men who depart from common practices, was looked on as a fanciful and wild cultivator, and because he paved his stables and cow houses, it was reported by his neighbors that he paved his vineyard. He wrote a great many works, chiefly on agriculture.

1. L'Art de Mâcon pisseur, extrait du Journal d'Observations sur la Physique, in 12mo.

2. Traité de la meilleure Manière de cultiver la Navette et le Colza, et d'en extraire une Huile dépourvue de son mauvaise Goût et de son Odeur désagréable. Paris, in 8vo. 1771.

3. Cours Complet d'Agriculture, Theorique, Pratique, Economique, etc. ou Dictionnaire universel d'Agriculture. 12 vols. in 1to. 1766.

1773. *Bexon, Gabriel Leopold Charles Ame*, a



miscellaneous writer, was born at Remiremont, 1748; died at Paris 1784: he had a great turn for Natural History, and assisted Buffon in the latter volumes of his great work.

1. Le Système de la Fertilization, 8vo.  
2. Catechisme d'Agriculture, ou Bibliothèque des Gens de la Campagne. 1773. 12mo.

1773. *Trother*.

L'Art de Fertiliser les Terres et de préserver de la Gelée, commodément et à peu de frais, les Arbres et Arbrisseaux, les Vignes, &c. Méthode d'Education nationale et Particulière. Paris, 5 vols. in 8vo.

1774. *Lerouge*, a friar of the order of Cîteaux, in the abbey of Trisay.

Principes de Cultivature, ou Essai sur la Culture des Champs, &c. avec un Traité abrégé des Maladies des Cultivateurs, de leurs Bestiaux, et des Remèdes pour les Guérir. 2 vols. in 12mo.

1778. *Buliard*, died at Paris in 1793.

Aviectionne Française, ou Traité général de Toutes les Ruses dont on peut se servir, pour prendre les Oiseaux qui sont en France. Paris, in 12mo.

1779. *Ameithon, Hubert Pascal*, a librarian in Paris, and member of the legion of honour.

Journal d'Agriculture, &c. depuis Janvier. 1779; jusqu'en Decembre, 1785. Paris. 15 vols. in 12mo.

1779. *Maupin*, valet de chambre to the queen of Louis XVI.

1. L'Art de la Vigne, contenant une nouvelle Méthode économique de Cultiver la Vigne. in 8vo.

2. Avis sur la Vigne, les Vins et les Terres. in 8vo. 1786.  
3. Almanach, ou Manuel des Vignerons de tous les Pays. Paris. in 8vo. 1789.

1780. *Bouthier*, advocate at Vienne in Dauphiny.

Le Citoyen à la Campagne ou Réponse à la Question: quelles sont les Connaissances Nécessaires à un Propriétaire qui fait valoir son Bien pour vivre à la Campagne d'une Manière utile pour lui et les Paysans qui l'environnent; dans le cas où les Propriétaires ne demeurent point dans leurs Biens, quelles seraient également les Connaissances Nécessaires pour que les Curés, indépendamment de leurs Augustes Fonctions, pussent être utiles à leurs Paroissiens. Genève. in 8vo.

1780. *Copincau, Abbe*.

Ornithologie artificielle. Paris. in 12mo. avec fig.

1780. *Mallet, Robert Xavier*, author of various works on gardening and rural subjects.

Précis Élémentaire d'Agriculture, &c. Paris, in 12mo. an iii.

1781. *Parmentier, Antoine Augustin*; born 1737, at Montdidier, in the department of La Somme, one of the most distinguished chemists and careful philosophers which have appeared in France; author of a great number of works, and co-operator in many others, as the *Annales de Chimie, Nouveau Cours d'Agriculture*; he is mayor of Enghien, and has a small garden there, richer stocked with rare plants than any other in Europe of its size. (See *Encyc. of Gard.* p. 1119.)

1. Recherches sur les Végétaux Nourrissants, qui dans les Terres de Disette, peuvent remplacer les Alimens Ordinaires. Paris. in 8vo.

2. Méthode facile pour Conserver à peu de Frais les Grains et les Farines. in 12mo. 1784.

3. Observations sur les Moyens de maintenir et de rétablir Salubrité de l'Air dans la Demeure des Animaux Domestiques. an xii.

4. Instruction sur les Moyens de rendre le Blé Moucheté propre à la Semence. Imp. roy. 1783.

5. Mémoire sur la Conservation et l'Usage des Biés de Turquie. Bordeaux. in 8vo. 1785.

6. Mémoire sur les Semailles. 1790.

7. Mémoire sur la Nature et la Manière des Engrais. 1791.

8. Mémoire sur les Clôtures.

9. Traité sur les Pommes de Terre, in 8vo. 1795.

10. Avis sur la Culture et les Usages des Pommes de Terre in 8vo.

11. Traité du Maïs, in 12mo.

1782. *Bertholot*, engineer to Louis XVI.

La Mécanique appliquée aux Arts, aux Manufactures, à l'Agriculture et à la Guerre. Paris. 2 vols. bound, in 4to. fig.

1782. *Cadet de Vaux, Antoine Alexis*, a distinguished patriot, founder of various useful institutions, and author of many projects for the public advantage, which have been carried into effect with success; author of and co-operator in many economical publications.

1. Avis sur les Biés germés. in 8vo.

2. Bibliothèque des Propriétaires ruraux, Journal d'Economie Rurale et Domestique; par une Société de Savans et de Propriétaires.

1782. *Parmentier, Deyeux*, and others. See 1781.

Bibliothèque Physico-Economique, instructive et amusante, à l'Usage des Villes et des Campagnes, (Paris. published monthly) 12mo. 68 vols. to 1825.

1784. *Dumont, Course*, of Boulogne, where he cultivates his own estate of Course, and has published a useful gardening work. (*Encyc. of Gard.* p. 1121, A. D. 1802.)

Mémoires sur l'Agriculture du Boulonnais, et des Cantons Maritimes voisins. Boulogne, in 8vo.

1715. *Chubert, Philippe*, inspector general of veterinary schools, and member of the legion of honor.

1. Instruction sur la Maniere de conduire et gouverner les Vaches Lactières, in 8vo.

2. Altération du Lait de Vache, désignée sous le Nom de Lait bleu, in 8vo. 1805.

3. D'une Altération du Lait de Vache &c. Paris, in 8vo. 1805.

1786. *Servieres, B. dc*.

Instruction sur la Manière de cueillir les Feuilles des Arbres de les conserver et de les donner à manger aux Bestiaux; Publiée par Ordre du Roi. in 8vo.

1787. *Amoreux*, a physician at Montpellier.

1. Mémoire sur les Haies destinées à la Clôture des Pres, des Champs, des Vignes et des Jeunes bois. Paris, in 8vo.

2. Mémoire sur la Nécessité et les Moyens d'Améliorer l'Agriculture dans le district de Montpellier, Avignon, &c. in 8vo.

1787. *Broussonnet, Pierre-Marie Auguste*, member of the legislative assembly, of the commission of monuments, and author of a number of papers in the Memoirs of the Paris agricultural society.

1. Année rurale, ou Calendrier à l'Usage des Cultivateurs. Paris. 2 vols. in 12mo.

2. Feuille du Cultivateur. 8 vols. in 4to. 1788.

1789. *Ciquot, Blerwache*, of Reims, inspector of manufactures and commerce.

L'Ami du Cultivateur, ou Essais sur les Moyens d'Améliorer en France la Condition des Laboureurs, des Journaliers, des Hommes de peine, vivant dans les Campagnes, et celle de leurs Femmes et de leurs Enfants. Paris. 2 vols. in 8vo.

1789. *Varenne, de Fenille, P. C.*, born at Bresse, and condemned to die by the revolutionary tribunal at Lyons in 1794, a zealous agriculturist, and much respected.

1. Observations, Expériences, et Mémoires sur l'Agriculture et sur les Causes de la Mortalité du Poisson dans les Etangs. Lyons, in 8vo. fig.

2. Observations sur les Etangs, in 8vo. 1798.

3. Ouvres d'Agriculture de Varenne Fenille, troisième et dernière Part: Mémoires et Expériences sur l'Agriculture, et particulièrement sur la Culture et l'Amélioration des Terres, le Dessèchement et la Culture des Etangs et des Marais, la Culture et l'Usage du Marais, &c. in 8vo. 1808.

1790. *Cotte, L.* a priest of the oratory author of some meteorological tracts.

1. Leçons élémentaires d'Agriculture, par Demandes et par Réponses, à l'Usage des Enfants, avec une Suite de Questions sur l'Agriculture. in 12mo.

2. Catechisme à l'Usage des Habitans de la Campagne, sur les Dangers auxquels leur Santé et leur Vie sont Exposés, &c. in 12mo. 1799.

1790. *Dubois, J. B.*, author of an interesting memoir on the hay forks made of the forked branches of the nettle tree in common use in the south of France.

Feuille d'Agriculture, d'Economie Rurale et Domestique, à l'Usage des Propriétaires, &c. in 4to.

1790. *Mayet, Etienne*.

Mémoire sur les Moyens de mettre en Culture, la plus Avantageuse les Terrains secs et arides, principalement ceux de la Champagne. in 8vo.

1791. *Abeille, F.* of Toulon.

Observations de la Société d'Agriculture, sur la Question suivante, proposée par le comité d'Agriculture et de Commerce de l'Assemblée Nationale; l'Usage des Domaines conjoyable est il Utile ou non aux Progrès de l'Agriculture. in 8vo.

1791. *Lamoignon Malesherbes, Chretien Guillaume*, a statesman, born at Paris, 1721, guillotined 1794; he was esteemed a patriot, a man of correct morals and elegant taste.

Idees d'un Agriculteur Patriote sur le Défrichement des Terres incultes, sèches et maigres, connues sous le Nom de Landes, Garrigues, Gâtines, Friches, &c. in 8vo.

1791. *Paillet*.

Instructions sur la Plantation, la Culture et la Récolte du Houblon. in 8vo.

1791. *Tessier, Henri Alexandre*, professor of agriculture and commerce in the central schools; he has paid great attention to the Merino breed of sheep, and the Angora variety of goat, of which government has put a large flock under his care.

1. Avis aux Cultivateurs, sur la Culture du Tabac en France, Publiée par la Société Royale d'Agriculture. Paris, in 8vo.

2. Journal d'Agriculture à l'Usage des Habitans de la Campagne. in 8vo. 1791.

3. Annales de l'Agriculture Française, by M. M. Tessier & Box. 12 Numbers annually, or 4 vols. 8vo.

4. Instruction sur les Moyens de détruire les Rats des Champs et les Mulots, Publiée par Ordre du Ministre de l'Intérieur, in 8vo.

5. Mémoire sur l'Importation à France des Chèvres à de duvet Cachemere. 8vo. pp. 32. Paris, 1819.

1792. *Coitezeaux, Francois*, an architect, but more occupied as an author.

1. Architecture Rurale, &c. Paris, in 8vo.

2. Cours d'Architecture rurale pratique, &c. in 8vo. avec figures, 1792.

3. Les Erreurs de mon Siècle sur l'Agriculture, 1793.

4. Almanach perpétuel des Cultivateurs. Paris, in 12mo. 1794.

5. Nouveau Traité d'Economie Rurale, in 8vo. 1803.

6. Des nouvelles Bergeries, de ce qui les constitue bonnes et tres salubres, in 8vo. 1805.

7. Des nouvelles Dispositions et Constructions des Faisaneries, et des Moyens de Multiplier les Faisans, avec la Manière d'élever les Oiseaux, &c. 1805.

8. Ecole d'Architecture Rurale. Lyon, in 8vo. an iv.

9. La Ferme. in 4to.

10. Nouveaux Murs de Terrasses solides et durables, et qui dispensent de toute Profession de Matériaux qu'on y emploie: Ouvrage utile à tous les Pays; principalement aux Architectes, Ingénieurs, Maçons, et tous Propriétaires, Agens, et Fermiers. in 8vo. 1805.

11. Traité de l'ancien Pisé des Romains, &c. Traité qui

ndique les Qualités, des terres propres au Pisé, les Enduits, &c. Traité sur les Manufactures et les Maisons de Campagne. Traité qui enseigne le nouveau Pisé, la Manière de le faire lors des Pluies, des Neiges et des Frimas. 8vo.

1792. *Olivier, G. A.*

Mémoire sur la Cause des Recoltes alternes de l'Olivier; du tort que les Oliviers éprouvent l'année de la Mauvaise Recolte. Moyens de se procurer des Recoltes annuelles et diminuer le Nombre des Insectes Rongeurs des Oliviers. Paris, in 8vo.

1794. *Belair, A. P. Julien de*, an engineer, formerly in the service of Holland and Prussia; he has written also on military subjects.

Mémoire sur les Moyens de parvenir à la plus grande Perfection de la Culture et de la Suppression des Jachères. in 8vo.

1794. *Bertrand*, inspector general of roads and bridges.

Avis important sur l'Economie Politique et Rurale des Pays de Montagnes, et sur la Cause et les Effets progressifs des Torrens, &c. Paris, in 8vo.

1794. *Fontalard, Jean Francois de*, of Lorraine.

Principes raisonnés d'Agriculture, ou l'Agriculture démontrée par les Principes de la Chimie Economique, d'après les Observations de plusieurs Savans; Ouvrage traduit en Français, sur la Version Latine de Jean Gottschalk Valerius de Stockholm. Paris, an li.

1794. *Huzard, Jean Baptiste*, veterinary surgeon of Paris, and member of several societies; Madam Huzard is the principal agricultural bookseller of Paris, as Harding is of London.

1. Essai sur le Maladies qui affectent les Vaches laitières des Environs de Paris, in 8vo.

2. Comte rendu à l'Institut de la Vente des Laines, et de 161 Bêtes du Troupeau National de Rambouillet, faite in prairial, an ix. in 4to. 1801.

3. Comte rendu à la Classe des Sciences, Mathématiques et Physiques de l'Institut National des Améliorations qui se font dans l'Etablissement Rural de Rambouillet, et Principalement de celle de Bêtes à Laine et de la Vente qui a eu lieu le 26 prairial, an xi. in 4to. 1803.

1794. *Preaudeau, Chemilly Eugene.*

Des Haies considérées comme Clôtures; de leurs Avantages et des Moyens de les obtenir, in 8vo.

1795. *Cels, Jacques Martin*, member of the Institute, of the Paris agricultural society, &c.

1. Annuaire du Cultivateur, ou Répertoire universel d'Agriculture, in 4to.

2. Avis sur les Recoltes des grains, publiée par le Conseil d'Agriculture du Ministère de l'Intérieur. Paris, in 8vo. (an vi.)

3. Instruction sur les Effets des Inondations et débordemens des Rivières, relativement aux Prairies, aux Recoltes de Poins, in 8vo. 1813.

1797. *Gilbert, Francois-Hilaire*, born at Châteaullault, in 1757, died at St Idefonso, near Madrid, in 1800, when in search of a flock of merinos; a man of great zeal for agriculture.

1. Instruction sur les Moyens les plus propres à assurer la Propagation des Bêtes à Laine de Race d'Espagne et la conservation de cette Race dans toute sa pureté, publiée par le Conseil d'Agriculture, in 8vo.

2. Mémoire sur la tonte du Troupeau National de Rambouillet, la Vente de ses Laines et de ses Productions disponibles, in 4to. 1797.

3. Recherches sur les Espèces de Prairies artificielles qu'on peut cultiver avec le plus d'Avantage en France. Paris, in 12mo. 1799.

1798. *Barbe-Marbois*, of Metz, who filled various civil offices, and was a grand officer of the legion of honor.

1. Culture du Trèfle, de la Luzerne et du Sainfoin. Metz, in 8vo.

2. La Richesse des Cultivateurs, ou Dialogues entre Benjamin Jachère et Richard Trèfle, Laboureurs, sur la Culture du Trèfle, de la Luzerne, et du Sainfoin. in 8vo. 1807.

1799. *Lasteyrie, Charles-Philibert-de*, member of various literary, philosophical, and agricultural societies, an active patriot and general philanthropist.

1. Traité des Bêtes à Laine d'Espagne; leur Voyages, la Tonte, le Lavage, et le Commerce des Laines, les Causes qui donnent la finesse aux Laines: auquel on a joint l'Histoire des Voyages que font les Moutons des Bouches-du-Rhône et ceux du Royaume de Naples; l'Origine, les Succès, l'Etat actuel du Troupeau de Rambouillet, et les Moyens de propager et de conserver la Race Espagnole dans toute sa pureté. in 8vo.

2. Histoire de l'Introduction des Moutons à laine fine d'Espagne dans les divers Etats de l'Europe, et au Cap de Bonne-Espérance; Etat actuel de ces Animaux; différentes Manières dont on les élève, les Avantages qu'en retirent l'Agriculture, les Fabriques, et le Commerce. 2 vols. in 8vo. 1805.

3. Mémoires sur différents points d'Economie Rurale. Paris, an viii.

4. Du Cotonnier et de sa Culture, ou Traité sur les diverses Espèces de Cotonniers, sur la Possibilité et les Moyens d'acclimater cet Arbruste en France, sur sa Culture dans différents Pays, principalement dans le Midi de l'Europe, et sur les Propriétés et les Avantages économiques, industriels, et commerciaux du coton. Paris, in 8vo. avec Planch. 1806.

5. Collection de Machines, d'Instruments, &c. employés dans l'Economie, Rurale, Domestique, et Industrielle, d'après les dessins faits dans diverses parties de l'Europe. 2 vols. in 4to. 200 Planches avec Texte. Paris, 1820.

1800. *Ducoudré*, a great bee master.

Notice sur les Tourbières et sur le Maniere de les exploiter; avec l'Art d'en créer dans toutes les Propriétés Rurales, pour augmenter la Quantité des Engrais, et des Combustibles. In 2 de Vilaine. 8vo.

1800. *Fabrè*.

Essai sur la Théorie des Torrens et des Rivières, contenant les Moyens les plus simples d'en empêcher les Ravages, d'en retrécir le Lit, et d'en faciliter la Navigation. Paris, in 4to.

1801. *Dralet*, of Toulouse, conservateur of forests, member of several societies. In 1810, his *Mole Catcher* had gone through nine editions. (*Bibliog. Agronomique*, 315.)

L'Art du Fauquier, in 8vo.

1801. *Lacoste*, of Plaisance, professor of Natural History at Clermont-Ferrard, and afterwards of morals at Toulouse.

Quelques Observations concernant l'Agriculture dans les Montagnes du Département du Puy-de-Dôme, in 8vo.

1802. *Daubenton, Jean Louis Marie*, co-operator with Buffon in the composition of his Natural History. "Buffon," says Cuvier "only listened to his imagination, while Daubenton always dreaded the influence of that frailty of his mind."

Instruction pour les Propriétaires de Troupeaux, avec d'autres Ouvrages sur les Moutons et sur les Laines, in 8vo.

1802. *Fromage de Feugre, C. Michel P.*, veterinary professor of Alfort, and author of many works on his profession.

Des Chenilles, des Avoines, et des Moyens d'empêcher leur Ravages. Paris, 8vo.

1802. *Pictet, Charles*, of Geneva, one of the conductors of the *Bibliothèque Britannique*.

1. Faits et Observations concernant la race des Mérinos d'Espagne à Laine superfine, et les Croisemens, in 8vo.

2. Quelques faits concernant la Race des Mérinos d'Espagne, à Laine superfine. Genève, in 8vo. fig. an viii.

3. Comparison de trois Charrues. 8vo. pp. 128. avec planche. Genève. 1825.

1802. *Rauch, F. A.*, engineer of roads and bridges.

Harmonie hydro végétale et Météorologique ou Recherches sur les Moyens de recréer, avec nos Forêts, la Floraison Temporelle et la Régularité des Saisons par des Plantations raisonnées. 2 vols. in 8vo.

1803. *Deprad, D.*, archbishop of Malines, ambassador of Buonaparte at Warsaw, and, since the restoration of the Bourbons, author of various political works, which have excited considerable interest.

De l'Etat de la Culture en France, et de ses Améliorations. 2 vols. in 8vo.

1803. *Dourches, Charles*, member of several societies.

1. Traité des Prairies et de leurs Irrigations. in 8vo.

2. Aperçu Général des Forêts. 2 vols. in 8vo. (an xliii.)

1803. *Sinety, André Louis Esprit*, member of several societies.

l'Agriculture du Midi, ou Traité d'Agriculture propre aux Départemens Méridionaux, &c. Marseille, 2 vols. in 12mo.

1804. *Jacquin, M. E.*

Instructions sur l'Economie rurale et domestique aux Habitans des Campagnes, Publiées par la Société d'Agriculture du Département des Deux-Sèvres. in 8vo.

1805. *Agoïn*, member of the Agricultural Society of Iveree.

Mémoire sur l'Amélioration du Troupeau de Mérinos et de Bêtes à Laine indigènes établi à la Mandria de Chivas, Département de la Loire, et sur les progrès de l'Agriculture dans ce domaine. in 8vo.

1805. *Tollard, Claude*, a physician, member of various societies, and who visited most parts of the continent; afterwards a nurseryman near Paris, and finally a corn merchant.

Traité des végétaux qui composent l'Agriculture de l'Empire Français, &c. in 12mo.

1806. *Bagot*, member of the Agricultural Society of the Seine.

1. Mémoire sur les Produits du Topinambour, Comparés avec ceux de la Luzerne, et de plusieurs racines légumineuses. Paris.

2. Annales de l'Agriculture Française, contenant des Observations et des Mémoires sur toutes les Parties de l'Agriculture.

1807. *Gacon Dufour, Marie Armande Jeanne*.

Dictionnaire Rural Raisonné, dans lequel on trouve le Detail des Plantes Preservatives et curatives des Maladies des Bestiaux.

1807. *Morel de Vindé*.

Mémoire sur l'Exacte Parité des Laines Mérinos de France et des Laines Mérinos d'Espagne, suivi de quelques éclaircissements sur la vraie Valeur que devrait avoir dans le Commerce les Laines Mérinos Françaises, in 8vo.

1807. *Prevost, Bénédicte*

Mémoire sur la cause immédiate de la Carie ou Charbon des Blés, et de plusieurs autres Maladies des Plantes et sur les Preservatives de la Carie Montauban. in 8vo.

1809. *Calvel, Etienne*, member of the Museum of Toulouse, and of other societies, author of various scientific works on rural subjects.

Mémoire sur l'Ajonc ou Genêt épineux considéré sous le Rapport de Fourrage, de l'Amendement des Terres Steriles et de Supplément au Bois. Paris, in 8vo.

1812. *Thouin, M. André*, Le Chevalier de, professor of culture in the University of Paris; author of various memoirs on gardening and agriculture, inserted in the French encyclopædias, dictionaries, and periodical works, and in the transactions of their learned bodies; an excellent man, and esteemed one of the first gardeners in Europe. He died in 1824. (See *Encyc. of Gard.* p. 1117.)

Description de l'Ecole d'Agriculture Pratique du Museum d'Histoire Naturelle. 4to.

1816. *Bonnemain*, a physician, member of several societies.

Observations sur l'Art de faire éclore et, à dériver la Volaille sans le secours des Poules, ou Examen des causes qui ont pu

empêcher aux diverses Tentatives qui ont été faites en Europe, pour imiter les Egyptiens. Paris, in 8vo pp. 36.

1816. *Chatelain, le Chevalier*, a cavalry officer. Mémoire sur les Chevaux Arabes; Projet tendant à augmenter et à améliorer les Chevaux en France; Notes sur les différentes Races qui doivent être préférées à ce sujet, &c. &c. Paris, 8vo.

1817. *Bornot, M. A.*, a notary at Savoisy. Pratique raisonnée de la Culture du Trèfle et de Sainfoin. Paris, 8vo, pp. 100.

1818. *Avrouin, Foulon*, mayor of Semblançay. Essai sur les défrichemens des Landes, et le desechement des Marais. Tours, 8vo, pp. 40.

1819. *Lullin, Ch. J. M.* Des Prairies artificielles d'Été et d'hiver; de la Nourriture des Bœufs, et des améliorations d'une Ferme dans les Environs de Genève, 2d edit. révisée et considérablement augmentée. Genève, 8vo, pp. 352.

1819. *Peyroure, Baron Picot de La.* A Sketch of the Agriculture of a District in the South of France. Translation with Notes. 8vo.

1819. *Villeneuve, Comte Louis de.* Essai d'un Manuel d'Agriculture ou Exposition du Système de Culture suivi pendant 19 ans dans le Domaine d'Hanterive, Commune de Cartres, Département du Tours. Toulouse, 8vo, pp. 908.

1819. *Yvart, A. Victor*, member of the Institute, and one of the writers in the *Nouveaux Cours d'Agriculture*, &c.

1. Excursion Agronomique en Auvergne, principalement aux Environs des Monts d'Or et de Puy-de-Dôme; suivie de Recherches sur l'État et l'Importance des Irrigations en France. Paris, 8vo, pp. 218.

2. Considerations générale et particulières sur la Jachère et sur les meilleurs Moyens d'arriver graduellement à sa suppression avec de grand Avantages. Imprimé par ordre de la Société Royale et Centrale d'Agriculture. Paris, 8vo, pp. 220. avec planches. 1822.

1820. *Autouin, Maurice.* Exposé du Projet d'établissement d'une Ferme expérimentale dans chaque Département du Royaume. Paris, 8vo, pp. 8.

1820. *Crud, Le Baron E. V. B.* the translator of Thaar's works from the German.

Economie de l'Agriculture. Genève, 4to, pp. 414.

1820. *Deslandes.* Elémens de l'Agriculture et des Sciences qui s'y rapportent, &c. Paris, 2 vols. 12mo, pp. 600.

1821. *Guillaume, Ch.* Instrumens aratoires, inventés, perfectionnés, dessinés, et gravés. Par Ch. G. Paris, oblong folio, pp. 26. avec 12 planches.

1821. *Lajons, M. de*, mayor of Atigat. Abrégé élémentaire d'Agriculture pratique, d'après les principes de Rozier, Arthur Young, Duhamel, &c.; principes appliqués à la Nature du Solles Pyréniées, à sa Température, &c. Toulouse, 8vo, pp. 532. avec fig.

1822. *Adamson, Madame Aglaé.* La Maison du Campagne. Paris, 8 vols. 18mo, pp. 1098.

1822. *François, Aisé.* L'Art de la Stercoration, ou les Loixirs d'un Agriculteur Practicien retiré à la Campagne; Méthode pour fabriquer une Quantité Immense de Fumiers qui dureront 8 Ans, tandis que les Fumiers ordinaires sont évaporés dans deux années. Toulouse, 8vo, pp. 48.

1822. *Morel de Vindé*, peer of France. 1. Quelques Observations pratiques sur la Théorie des Assolemens. Paris, 8vo.

2. Essai sur les Constructions rurales économiques contenant leurs Plans, Coupes, Elevations, Détails, et Dévis établis aux plus bas Prix possibles. (Les détails de Constructions et divis, par A. L. Lusson, Architecte.) Paris, in folio, pp. 40. avec 36 planches.

1822. *Morogues*, Baron de. Essai sur les Moyens d'améliorer l'Agriculture en France, particulièrement dans les Provinces les Moins riches, et notamment en Soulogne. Paris, 2 vols. 8vo, pp. 932.

1822. *Thiery, P. J.* (officier comptables du dépôt royal d'étalons de Strasbourg.)

Mémoire sur l'Amélioration des Chevaux en Alsace, par le croisement des Races et l'Éducation, et particulièrement sur les Moyens de les préserver de la Cécité. Mémoire Couronné, &c. Strasbourg, 4to, pp. 160. 1822.

1822. *Polignac, Comte Charles de.* Rapport au Roi sur les Troupeaux de pure Race, expliquant les Motifs et les Developpemens des nouveaux Principes d'Administration pratiqués dans son établissement rural de Calvados. 8vo. Caen, 1822.

1823. *Chaptal*, Comte, a distinguished chemist and statesman, who cultivates a considerable part of his own estate.

La Chimie appliquée à l'Agriculture. Paris, 2 vols. 8vo.

1823. *Bosc, Th.* vice president de la Société d'Agriculture du Dents.

1. Rapport sur l'emploi du Plâtre en Agriculture fait au Conseil Royal d'Agriculture. Paris, 8vo, pp. 108.

2. Traité élémentaire de Physique végétale appliquée à l'Agriculture. Paris, 1824. 8vo, pp. 110.

1824. *Dubois, Louis.* Cours complet et simplifié d'Agriculture et d'Economie rurale et domestique. Paris, 6 vols. 12mo.

1824. *Mathieu de Dombasle, C. J. A.* Annales Agricoles de Roville, ou Mélanges d'Agriculture, d'Economie rurale et de Legislation Agricole. Première livraison. Paris, 8vo.

1824. *Mortemart-Boisse*, le Baron de. Recherches sur les différentes Races des Bêtes à Laine de la Grande Bretagne, et particulièrement sur la nouvelle Race de Leicester-shire. Paris, 8vo.

1824. *Polonceau, M.* Notice sur les Chèvres Asiatiques à Duret du Cauchemere, et sur un premier Essai tenté pour augmenter leur Duret, et lui donner des Qualités nouvelles, &c. Paris, 8vo.

1825. *La Societe d'Agriculture et Centrale.* Annuaire de la Société Royale et Centrale d'Agriculture 8vo. (Continued Annually.)

SUBSECT. 2. Bibliography of German Agriculture.

7113. The German agricultural works are as numerous as those of the French, but chiefly translations, and these, for the most part, from the English. We have given a very limited selection, the German language being less generally understood than either the French or Italian. In forest management (*Forstwissenschaft*) the German bibliography is very rich, and it is chiefly these books, and descriptions of local practices, which can be of any interest to the British cultivator. The older German works in rural affairs are enumerated in Haller's *Bibliography*; and the modern ones, and new editions in Ersch's *Handbuch der Deutschen Litteratur*, and the *Leipsic Catalogues*, published annually. Thaar of Mœglin is decidedly the highest in repute as an author, and Sickler's *Deutsche Landwirthschaft*, a voluminous work, will give a general idea of every part of German husbandry.

1578. *Heresbachius, Conradus*, counsellor to the Duke of Cleve; was born in 1508, died in 1576. He wrote various theological works, besides his *Rei Rusticæ*, libri iv., which was published in 1570, and his *Legum rusticarum, et operarum per singulos Menses digestæ*, in 1595. The former was translated by Barabaz Gooch, of Lincolnshire, with the following title:

Four Books of Husbandrie, containing the whole Art and Trade of Husbandrie, Gardening, Grafting, and Planting, with the Antiquitie and Commendation thereof. Newly Englished and increased by Barnebe Geoge, Equire. At London, 4to. 1578. Leaves 164, besides the Dedication, Epistle and Table at the beginning; and Old English Rules in Verse for purchasing Land, at the end.

His authorities extend from the Bible and doctors of the church, through the Greek and Roman writers, Homer, Cato, &c., to the moderns as low as Ruellius, Fuchsius, Matthiolus, Cardanus, and Tragus. He subjoins a list of his friends and others who assisted him. S. Nieh. Malbec, M. Cap. Byng-ham, M. John Soimer, M. Nicas. Yetzwert, M. Fitzherbert, M. Willi. Lambert, M. Tusser, M. Tho. Wherenthal, M. Ri. Deering, M. Hen. Brookhull, M. Frankliu, H. King, Richard Andrews, Henry

Denys, William Pratte, John Hache, Philip Partridge, Kenworth Daforth.

The work is in dialogue. The persons are Cono, a gentleman retired into the country; Rego, a courtier; Metella, wife of Cono; and Hermes, a servant.

1591. *Colerus, J.* 1. Calendarium œconomicum et perpetuum. Wittebergæ.

2. Economie famus prima, qua tractatur quemadmodum bonus œconomicus saporibus suos regere debet et bona sua augere potest; per varias honestas artes, et utilia compendia circa res domesticas, Agriculturam, Piscatum, Aucupia, Venationes et Vinearum Culturam. Wittebergæ, 4to. 1595.

1592. *Porta, J. B.* Villas, lib. xiii. B. Confurti, 4to.

1735. *Zeigerus, Antoine.* Introductio rationalis ad œconomiam et artem perficiendæ Agriculturæ, in qua methodus exponitur experientiâ confirmata omnesque agrorum sine consuetâ stercoreatione fecundandi. 4to.

1754. *Eckhart, J. Gli. von.* Experimental Oekonomie über das Animalische, Vegetabilische, und Mineral Reiche, oder vollständige Haushaltungs- und Landwirthschaftskunst. Jena, 1754. 8vo.

1760. *Der Schweizer.* Gesellschaft in Bern Sammlung von Landwirthschaftlichen

- Dingen; oder Abhandlungen und Beobachtungen durch die ökonomische Gesellschaft in Bern gesammelt. Zurich, 8vo.
1762. *Wiegand, J.*  
Wohlfahrt Landwirth; oder Anleitung wie der Landwirthschafts Oekonomie zu verbessern. Wien, 8vo.
1766. *Cramer, John Andreu*, died 1777.  
Anleitung zum Forst-Wein. Braunsch. fol.
1766. *Dericule*.  
Mémoires de l'Agriculture en générale, et de l'Agriculture de Pologne en particulier. Berlin, 8vo.
1769. *Lüders, Ph. E.*  
Grundriss einer zu errichtenden Ackerschule, in welcher die Landjugend zu einer richtigen Erkennntnis und Uebung im Landbau eingeführt und zubereitet werden könne. Flensburg, 8vo.
1773. *Krinitz, J. G.*  
Ökonomische technologische Encyclopädie, oder allgemeines System der Staats, Stadt, Haus, und Landwirthschaft in Alphabetischer Ordnung. Berlin, 8vo.
1775. *Albrecht, J. F. E.*  
Zootomische und Physikalische Entdeckungen von der innern Einrichtung der Bienen, besonders der art ihrer begattung. Gotha, 8vo.
1775. *Suckow, G. Adg.*  
Abhandlung von Nutzen der Chemie zum Behuf des bürgerlichen Lebens und der Oekonomie. Mannheim, 8vo.
1779. *Borcke, H. A. Grafen*, Count de.  
Account of the Management of his Estate of Starfordt, in Pomerania. Berlin, 4to. in German.
1780. *Christ, J.*  
Patriotische Nachrichten, &c.; or, Patriotic Accounts and Instructions concerning the profitable Culture of Tobacco, and more especially of that called Asiatic Tobacco. Francf. 8vo.
1781. *Rössig, Karl Glo*, author of some works on gardening and forest management.  
Versuch einer pragmatischen Geschichte der Oekonomie, Polizey und Cameralwissenschaften, seit dem 16 ten Jahrhunderte, bis auf unsere Zeiten. Deutschland Leipzig, 8vo.  
2. Die Geschichte, der Oekonomie der vorzüglichsten Länder und Völker der älttern mittlern und neuern Zeit in einem kurzen Entwurff dargestellt. Leipzig, 8vo. 1798.
1784. *Hiltbrand, Ant.*  
Erste Aufangsgründe der zur Landwirthschaft nütigen Mechanik. Wien, 8vo.
1784. *Hofmann, Gli. Bd. Freyherr von*.  
Die Landwirthschaft für Herrn und Diener. Prag. 8vo.
1785. *Fischer, C. F. J.*  
Geschichte des Deutschen Handels, der Schiffahrt, Fischerey, Erfindungen, Künste, Gewerbe, der Landwirthschaft, Polizey des Zoll-Münz- und Bergwesens, der Staatswirthschaft und des Luxus. Hannover, 2 vols, 8vo.
1786. *Hartig, Fr. Grafen von*.  
Historische Untersuchung über die Aufnahme und den Verfall der Feldwirthschaft bey verschiedenen Völkern. Prag und Wien, 8vo.
1786. *Rizhaub*.  
Brevis rei rustice Descriptio. Giessen, 12mo.
1790. *Hartiz, Georges-Louis*.  
Observations Historiques sur les Progrès et la Décadence de l'Agriculture chez differens Peuples. Vienne, 5 vols, 8vo. 1791.
- Kleine Schriften zur Stadt- und Landwirthschaft von der ökonomischen Gesellschaft in Bern herausgegeben. Zurich, 8vo.
1791. *Nan, Bh. Seb.*  
Theoretisch praktisches Handbuch für Oekonomie, Bergbaukunde, Technologie und Thierarzneywissenschaft (in Alphabetischer Ordnung) von einer Gesellschaft bearbeitet Zurich, 8vo.
1792. *Bose, K. Ad. H. von*.  
Katechesisches Unterricht zum Feldbau oder freundschaftliche Gespräche über die vorzüglichsten Gegenstände der alten und neuen Landwirthschaft; nebst einem Anhang, wie die Wohn- und Wirtschaftsgebäude unf kleinen Rittergütern und grossen Bauerntütern bequem und wohlful anzulegen. Halle, 8vo.
1792. *Riem, J.*  
1. Monatlich praktisches ökonomische Encyclopädie für Deutsche, oder zusammenhängender Lehrbegriff der gemeinnützigsten praktischen Wirtschaftskunde, &c. Leipzig, 8vo.  
2. Modell Magazin für Oekonomen; oder Abbildungen und Beschreibungen der nützlichsten und bequemsten Geräthschaften, Werkzeuge und Geschirre für Haushaltung, Landwirthschaft, Viehzucht, &c. Leipzig, 1802, 4to. mit Kupfern.
1794. *Stumpf, G.*  
Biographie und Schicksale des ökonomisch cameralistischen Instituts zu Jena; mit den nöthigsten Documenten. Jena, 8vo.
1796. *Huber, Francis*, member of the Society of Natural Philosophy and Natural History of Geneva.  
Nouvelles Observations sur les Abeilles, adressées à M. Charles Bonnet. Par. 12mo.
1796. *Zehmens, Cp. H. Adf. von*.  
System der Landwirthschaft, nach physischen und chemischen Grundsätzen behandelt, und durch lange Erfahrungen geprüft. Leipzig, 8vo.
1797. *Fischer, H. L.*  
Katechismus der Haushalt und des Ackerbaues zum Gebrauch in Schulen. Braunschweig, 8vo.
1797. *Krantz, Gulluame*.  
De l'Agriculture comme Source principale du Bien-être et de la Prospérité d'une Nation. Vienne, 8vo.
1798. *Thaer, Alb.* of the establishment of Mögeln in Prussia, one of the most enlightened Ger-

- man agriculturists, author of numerous works, all in high repute. (572.)
1. Einleitung zur Kenntniss der Englischen Landwirthschaft. Hannover, 8vo.
2. Veranschaulichte landwirthschaftliche Schriften aus der drey ersten Jahrgängen der Annalen der niedersächsischen Landwirthschaft, ausgewählt und anzugsweise in Ansehung der eignen Arbeiten verbessert. Hannover, 8vo. 1806.
3. Grundsätze der rationellen Landwirthschaft. Berlin, 4to. 1809.
4. Annalen der niedersächsischen Landwirthschaft herausgegeben von der Braunschweigischen Landwirthschafts Gesellschaft durch Alb. Thaer und J. Kr. Bencke. Zeile. 8vo. 1799.
1799. *Anton, K. Glo*.  
Versuch einer Geschichte der deutschen Landwirthschaft von den ältesten Zeiten bis zu Ende des 15 ten Jahrhunderts. Gölritz, 8vo.
1800. *Rückert, G. Ch. Alb.*  
Bemerkung über Thaers Einleitung zur Kenntniss der Englischen Landwirthschaft. Wien, 8vo.
1800. *Steindel, A. H. von*.  
Bemerkungen über Thaers Schreiben, &c. Leipzig, 8vo.
1801. *Huber, P.*, of Lausanne, in Switzerland, and son of Francis, previously mentioned.  
1. Memoirs concerning the Influence of the Air, and several gaseous Substances, on the Germination of various kinds of Grain. Geneva, 8vo.  
2. Recherches sur les Mœurs des Fourmis Indigènes. Par. 1810.
1802. *Costa, Ch.*  
Essai sur l'Amelioration de l'Agriculture dans les Pays Montueux, et en particulier dans la Savoie. 8vo.
1802. *Eschenbach, Ch. Ghid*.  
Kunstmagazin der Mechanik und technischen Chemie; oder Sammlung von Abbildungen und Beschreibungen erprobter Maschinen, zur Vervollkommnung des Ackerbaues, der Manufacturen und Fabriken. Leipzig, 4to.
1802. *Gotthard, J. Ch.*  
Das Ganze der Landwirthschaft; ein Systematisches Lehrbuch für Oekonomen, so wie für jeden, der sich dieser Wissenschaft widmet. Mainz, 8vo.
1803. *Engel, Lud. Hm. Hs. von*.  
Anwendung der Englischen Landwirthschaft auf die Deutsche und beide gegen einander gestellt nach Thaer's Einleitung. Leipzig, 8vo.
1803. *Hermstädt, Sgm. F.*  
Archiv der Agricultur-Chemie, für denkende Landwirthe; oder Sammlungen der wichtigsten Entdeckungen, Erfahrungen und Beobachtungen in der Physik und Chemie, &c. Berlin.
1803. *Weber, F. Bd.*  
Handbuch der ökonomischen Literatur; oder Systematische Anleitung zur Kenntniss der Deutschen ökonomischen Schriften, die sowohl die gesammte Land- und Hauswirthschaft, als die mit denselben verbundenen Hülf- und Nebenwissenschaften angehen; mit Angabe ihres Ladenpreises und Bemerkung ihres Werths. Berlin, 8vo.
1804. *Richter, K. F.*  
1. Chemisch Oekonomisches Taschenbuch für Wirtschaftsbearbeiter, oder Darstellung der chemischen Elementargesetze welche mit der Oekonomie in der engsten Verbindung stehen. Chemnitz und Leipzig, 8vo.  
2. Historische, Tabellarische Darstellungen der in jedem Monate vorkommenden Landwirthschaftlichen Arbeiten; auf jedes Jahr anwendbar, für Rittergutsbesitzer, Pächter und Verwalter. Chemnitz und Leipzig, fol. 1804.
1805. *Sickler, F. Ch. L.*, and son to the celebrated German pomologist, author of some interesting gardening works. (See *Encyc. of Gard.* p. 112c.)  
Le Spirodiphire, ou Char à Planter le Blé, avec deux planch. Paris, 8vo.
1808. *Fellenberg, Emmanuel*, of the celebrated agricultural establishment in Switzerland already noticed (343.)  
1. Rapport à S. Ex. le Landamman et à la Diète des 19 Cantons de la Suisse, sur les Etablissements agricoles de M. Fellenberg à Hofwyl, par M. M. Heer, &c. Paris et Geneve, 8vo.  
2. Vues relatives à l'Agriculture de la Suisse, et aux Moyens de la perfectionner. Geneve, 1808.  
3. Anstalten der schweizer Landwirthschaft und des zweckmässigsten Mittels sie zu vervollkommen. Carlsruhe, 8vo. 1809.
1808. *Escher, von Berg*.  
Brieft über die Fellenbergische Wirthschaft zu Hofwyl. Zurich, 8vo.
1808. *Theress, Thdr.*  
Theoretisch-Praktisches Handwörterbuch der gesammten Landwirthschaft; oder Anweisung zur Kenntniss, Behandlung und Benützung aller Landwirthschaftlichen Gegenstände, als des Feld- und Gartenbaues, der Viehzucht, &c. Göttingen, 8vo.
1809. *Hoffmann, A.*  
Ueber Fellenbergs Wirthschaft in Hofwyl; nebst Anmerkungen und eine Nachschrift von Alb. Thaer (aus den Annalen des Ackerbaues). Berlin, 8vo.
1809. *Scheffold, L.*  
Berichtigung des helvetischen National Rapports über die Landwirthschaftlichen Anstalten des Herrn Em. Fellenbergs zu Hofwyl. Erlangen, 8vo.
1809. *Trantman, Cp.*  
Lehrplan der Landwirthschaft. Wien, 8vo.
1810. *Schönlentner, M.*  
Nachrichten über die königliche Landwirthschaftsschule in Weißenstephan und über das dort eingeführte Thaersche Ackerstystem. München, 8vo.

SUBSECT. 3. *Bibliography of Italian Agriculture.*

7114. A number of *Italian agricultural works* have been published: such as they are, perhaps more of them are original than the books of the French or Germans, because the culture of other parts of Europe is but ill adapted for Italy. The vine, olive, mulberry, orange, and the irrigation of lands, have a good deal occupied the Italian writers. Re may be reckoned their general and popular author, and his *Nuovi Elementi*, 4 vols. 8vo. 1815, and *Annali del Agricoltura*, &c. 22 vols. 8vo. to 1814, will give a good idea of Italian husbandry and gardening, & the two arts in that country being for the most part combined.

1471. *Crescentus, Crescenzo, or De Crescentiis*, was born at Bologna about 1233; died 1320.

1. *Opus Ruralium Commodorum sive de Agricultura*, libri xli. Augsburg, fol.

2. *De Agricultura, Omnibusque Plantarum et Animalium Generibus*. Basil, 1538.

1496. *Bertochus, Dionysius*, of Bologna, who printed some very early works at Vicenza. *Scriptores de Rustica*. This contains the Agricultural works of Columella, Varro, Cato, and also of Palladius, &c.

1546. *Alamanni, Luigi*.

Della Coltivazione. Rome. 8vo.

1564. *Gallo, Agostino*.

1. Le dieci giornate della vera Agricoltura, e Piaceri della villa: in Dialogo. Bresc. ap. G. B. Bozzola. 4to.

2. La Vinti Giornate dell' Agricoltura, e de' Piaceri della villa. Turin, 1579. 4to.

1622. *Soderini, Giovanvettorio, e Bernardo Davanati*.

Coltivazione Toscana delle viti e d' alcuni alberi. Aggiuntovi coltivazione degli olivi, di Pietro Vettori. Firenze. 4to.

1628. *Castelli, Benedict*, an Italian mathematician, and the particular friend of Galileo, was born at Brescia, in the year 1577; died about 1640.

*Treatise of the Mensuration of Running Waters; also Letters and Considerations touching the Draining of Fens, Divisions of Rivers, &c.* Translated by Thomas Salisbury. Lond. 1661. fol. Published at Rome in 1628.

1651. *Fanara, Vincenzo*.

L'Economia del Cittadino in villa. Roma, in 4to.

1748. *Borro, Aless.andro del*.

Dimostrazioni e prove sopra l'altivita, ed uso vantaggioso del Gran Coltro. Milano, in 4to. fig.

1736. *Aquino, Charles d'*.

Nomenclator Agriculture. Rome, in 4to.

1758. *Gavellus, Nicholas*.

Storia distinta, e curiosa del Tabacco, concernente la sua scoperta, la Introduzione in Europa, e la Maniera di coltivarlo, conservarlo, e prepararlo. Pesaro. 8vo.

1764. *Alamanni*.

La Coltivazione e gli epigrammi, colle Api di Gio. Ruellai, ed annotaz. Parma, in 12mo.

1767. *Cattaneo, Giacomo*.

Della Idropisia de' Gelsi. Milano, in 8vo.

1772. *Tarello, Camillo*.

1. Ricordo d' Agricoltura colle note del Padre Scottoni. Venezia, in 4to.

2. Ricordo d' Agricoltura corredato d' Annotazioni da Paolo Sangorgio. Milano, 1816, in 8vo.

1776. *Cauciana*.

Saggi sopra la Legislazione propria alle arti dell' Agricoltura. Udine, in 8vo.

1777. *Salvini Gio*.

Istruzione al suo fattore di campagna, in cui si da una piena notizia di tutto ciò ch' appartiene alla maggior promozione dell' arte agraria, e suoi metodi, &c. Venezia, in 8vo.

1778. *Cantani, Carlo Antonio*.

Istruzioni pratiche intorno all' Agricoltura, e tenuta dei Bigatti. Berg. in 8vo.

1778. *Castellet, Constans*.

Istruzioni circa il modo di coltivare i gelsi, di allevare i bachi da seta, e di filar le sete, con nuove applicazioni e riflessioni. Torino, in 8vo.

1778. *Biedè, M*.

Trattato sopra la coltivazione delle viti; di del modo di fare i vini e di governarli. Venezia, in 8vo. fig.

1780. *Bertrand*.

Elementi di Agricoltura fondati sui fatti e sui raziocinil ad uso delle persone di campagna. Vicenza, in 8vo.

1780. *Carrera Antonio*.

Dissertazione sull' Economia Rurale. Venezia, in 8vo.

1781. *Brugnone, Gio*.

1. Trattato delle razze de' cavalli, col disegno della fabbrica della regia mandra di Chivasso, e quello dei pascoli e prati. Torino, in 8vo. fig.

2. *Boometria*, o sia della conformazione esterna del corpo delle bestie bovine, delle loro bellezze e difetti, e delle avvertenze da aversi nella loro compra. Torino, 1802, in 8vo.

3. *Ippometria*, o sia della conformazione esterna del Cavallo, dell' Asino e del Mulo, delle loro bellezze e difetti, e delle attenzioni da aversi nella loro compra. Torino, 1802, in 8vo.

1785. *Amoretti*.

1. Istruzioni pubblicate della Società Patriottica di Milano, intorno ad alcuni quesiti della medesima proposti per l' anno 1785, in 4to.

2. Della coltivazione delle patate e loro uso. Milano, 1801, in 8vo. fig.

3. Delle Torbierie esistenti nel dipartimento d'Ona e limitrofi, e dei loro vantaggi ed usi. Milano, 1807, in 4to.

4. Coltivazione delle Api nel Regno d' Italia. Milano, 1811, in 8vo. fig.

5. Della Torba e della lignite nel Regno d' Italia, Milano, in 8vo. fig.

6. Domande relative all' Agricoltura. Mil. in 4to.

1785. *Barbaro, Marco*.

Esperimenti sopra il grano fermentato, ed altre agrarie scoperte. Milano, in 8vo.

1790. *Rocca, Abbè Della*, vicar general of Scyros.

Traité complet sur les Abeilles, &c. &c. A Complete Treatise on the Management of Bees, as practised at Scyros, together with an Account of that Island. Paris. 8vo.

1791. *Caronelli, Pietro*.

1. Apotegni Agrarii, o sia istruzioni per via di massime tratte dalle opere de' due insigni agronomi Catone e Varrone. Venezia, in 8vo.

2. L' Agricoltura Italiana ridotta in proverbi, ovvero istruzioni per via di massime tratte dalle opere de' due insigni agronomi Catone e Varrone. Venezia, 1807, in 8vo.

1793. *Lastri, Proposto*.

Calendarj dodici, o sia Corso completo d' Agricoltura pratica. Venezia. vol. iv., in 8vo.

1798. *Comparetti*.

Saggio sulla cultura e governo dei Boschi. Padova, in 8vo.

1798. *Doria, Luigi*.

Istituzioni georgiche per la Coltivazione de' grani ad uso delle campagne romane. Roma, in 8vo. fig.

1800. *Liby, Cav*.

Three Memoirs on Agriculture; 1. On the Use of the Alga Marina in Agriculture and in the Arts; 2. On the Treatment of Vines; 3. On the Economy of the Flour which lies away in the Mill, and during the separation of the Bran. Palermo.

1801. *Simonde, J. C. L.*, a distinguished literary character who formerly managed an estate in the Vale of the Arno.

Tableau de l' Agriculture Toscane. Genève.

1802. *Fubroni, Adamo*.

Dissertazione sopra il quesito: indicare le vere Teorie, con le quali devono eseguirsi le stime dei terreni, &c. Firenze, in 8vo.

2. Della economia agraria dei Chinesi. Memoria. Venezia, 1802, in 8vo.

1802. *Targioni, Luigi*.

1. Lezioni di Agricoltura specialmente Toscana. Firenze, vol. xi., in 8vo.

2. Memorie su l' Agricoltura, la Pastorizia, e l' Applicazione dei Naturali prodotti agli usi degli abitanti dell' Italia, ed alla loro industria. Napoli, 1814, vol. ix., in 8vo. fig.

1803. *Carradori, Gioachino*.

Della fertilità della terra. Pisa, in 8vo.

1803. *Vallec, Alexandre*.

Instructions élémentaires d' Agriculture, ou Guide Necessaire au Cultivateur, traduit de l' Italien de Fubroni.

1804. *Ronconi, Ignazio*.

Dizionario d' Agricoltura, o sia la Coltivazione Italiana, in cui si contiene la cultura e conservazione dei diversi prodotti riguardanti le terre seminatve, i prati, i boschi, le vigne, ed i giardini, &c. Venezia, vol. v., in 8vo.

1805. *Piacenza, Giovanni*.

Nuovo metodo di fare le misure dei fieni, a che si aggiunge qual sia la migliore Agricoltura de' prati. Milano, in 8vo.

1807. *Barella, Giuseppe*.

1. Della Malattia della Golpe del grano turco. Milano, in 8vo. fig.

2. Saggio intorno la Fabricazione del Cacio detto Parmigiano. Milano, 1808, in 8vo.

3. Monografia Agronomica del Cereali del Frumento, trattato diviso in tre parti. Milano, 1809, in 8vo., con rami e tavole.

1807. *Biroli, Giovanni*.

1. Del riso, trattato economico rustico. Milano, 8vo.

2. Trattato di Agricoltura. Novara, 1812, vol. iv. in 8vo. con tavole.

1807. *Galeotte, Francesco*.

Metodo per migliorare ed accrescere l' Agricoltura nello stato di Parma. Parma, in 8vo.

1807. *Gautieri, Giuseppe*, inspector of woods and forests to the Viceroy of Lombardy, author of a tract on forests. (See *Encyc. of Gard.* p. 1128.)

1. Della ruggine del Frumento. Milano, in 8vo. fig.

2. Dei vantaggi e dei danni derivanti delle capre in confronto delle pecore. Mil. 1816, in 8vo.

1808. *Abbate, Antonio*.

Coltivazione dei Bigatti o sia Metodo pratico per farli nascere, coltivarli nei varj periodi della loro vita, e fabbricarne la semente. Milano, 8vo.

1808. *Re, Filippo*, librarian to the Patriotic Society at Milan, afterwards in the employ of Government, at Turin, where he died in 1820 or 1821. He wrote a great number of works on rural and economical subjects.

1. Elementi di economia oompestre ad uso de' Locat. Milano, in 8vo. carta fina.
2. Annali dell' Agricoltura del regno d' Italia cominciati in Gennaio 1809, e terminate in Giugno, 1814, fascicoli 66, formanti 22 vol. in 8vo. con circa 30 tavole e tavole.
3. Del Cotone, e delle avvertenze per ben coltivarlo. Milano, 1811, in 8vo.
4. Nuovi Elementi di Agricoltura, volumi 4 in 8. Dedicati a S. A. R. Francesco IV. d' Este, Duca di Modena, ec. ec.
5. Dei Letami e delle altre sostanze adoperate in Italia per migliorar i terreni e del come profitarne; Saggio. Milano, 1816, in 8vo.
6. Saggio sopra la Storia e il Coltivamento dell' Erba Medica. Milano, 1817, in 8vo.
7. Saggio storico sullo stato e sulle vicende dell' Agricoltura Antica dei paesi posti fra l' Adriatico, l'Alpe, e l' Appennino, sino al Fronto. Mil. 1817. 8vo.
1807. *Tuppiti, D.*  
Reflexions sur l'Etat de l'Agriculture et de quelques autres parties de l'Administration dans le Royaume de Naples, sous Ferdinand IV.; précédées d'une Introduction ou Coup-d'œil sur l'ancien Etat de ce Pays, et suivies d'un Mémoire intitulé, Recherches sur la Plante vulgairement nommée Storta dans le Royaume de Naples, in 8vo.
1809. *Arduino, Luigi.*  
1. Memoria intorno la coltura ed usi economici del Cinoauo Corakan. Mil. 8vo. fig.  
2. Nuovo metodo per estrarre lo zucchero dalle canne dell' Olio di Caferra. Padova, 1811, 8vo. fig.
1809. *Tozzetti, Oct. Targ., M.D., professor of agriculture at Florence, and director of different national establishments there.*  
1. Dizionario dei Nomi di Botanica e di Agricoltura, Latino-Italiano e Italiano-Latino. Firenze, 2 vols. 8vo.  
2. Lezioni d'Agricoltura. Firenze, 6 vols. 8vo.
1810. *Benetti, Santo.*  
L'acconto Fattor di Villa, o sia Osservazioni utili ad un fattore per il governo della Campagna e per la soprintendenza ai Coloni. Venezia. 8vo.
1810. *Spadoni, Paolo.*  
1. Modo di coltivare il Napo Silvestre detto volgarmente Ravizzone, e del metodo di cavarne l'olio alla maniera dei Bolognesi. Venezia. 8vo.  
2. Dello stabilimento, piantagione e conservazione delle siepi, con il disegno per ben formarle. Venezia, 1810. 8vo.
1811. *Albertazzi, Jacopo Antonio.*  
Il Padre di famiglia in casa ed in campagna. Milano, vol. vi. 12mo.
1811. *Giacinto, P. Carlo, professor of botany in Malta.*  
Agricultural Essays, adapted to the Island of Malta. Messina.
1811. *Lampadius, Augusto Guglielmo.*  
Esperimenti sopra lo zucchero di Barbabietole. Novara. 8vo.
1811. *Losana, Matteo.*  
Delle Malattie del Grano in erba non curate o ben conosciute. Carmagnoli. 8vo.
1811. *Bassi, Agostino.*  
I. Il Pastore benè istruito. Milano. 8vo.
2. Dell' utilità ed uso del Pomo di Terra, e del metodo migliore di coltivarlo. Lodi, 1817. 8vo.
1812. *Dandolo, Vincenzo.*  
1. Nuovi cenni sulla coltivazione de' Pomi di Terra, e vantaggi della melissima, rapporto al ben essere dell' uomo e dello stato, Lettera al Cav. Filippo Be. Como. 8vo.  
2. Enologia, ovvero l'Arte di fare, conservare, e far viaggiare i vini del Regno d' Italia. Milano, 1812, vol. ii. 8vo. fig.
1812. *Lullin, J. M.*  
1. Almanach du cultivateur du Leman. Genève, 8vo.  
2. Delle «raterie artificiali d'estate e d'inverno, del nutrimento delle pecore e miglioramento di una tenuta. Firenze, 1817, vol. ii. 8vo.
3. Des pratiques artificielles d'été et d'hiver, de la nourriture des bœufs et de l'abâtardissement d'une ferme dans les environs de Genève. Paris, 1819. 8vo.
- Gagliardo, G. B.*  
Catechismo agrario per uso de' curati di campagna e de' fattori delle ville. Napoli, terza edizione, con aggiunte. 8vo.
1815. *Galliziotti, Filippo.*  
Sulla dimora alla campagna dei ricchi possidenti e dell' utilità dell' istruzione degli ecclesiastici nell' agricoltura. Firenze. 8vo.
1815. *Malenotti, Ignazio.*  
Il padrone contadino, osservazioni agrario-critiche. Colle. 8vo. fig.
1816. *Fiorochi, Anton. Maria.*  
Regole teoriche-pratiche e rustico-legali per fare le stime dei predj rustici. Firenze. 8vo.
1816. *Ricci, Jacopo.*  
1. Catechismo Agrario. Firenze. 8vo.  
2. Del vino, delle sue malattie, e dei suoi rimedj, e dei mezzi per iscoprirne le falsificazioni; dei vini artificiali, e della fabbricazione dell' aceto. 8vo.
1816. *Onorati, Nicola Columella.*  
1. Delle patate, loro coltura, uso economico, e maniera di farne il pane. Milano. 18mo.  
2. Saggi di economia campestre e domestica per dodici mesi dell' anno, ad uso degli agricoltori, dei pastori, e di altra gente industriosa. 18mo.  
3. De' Vinaccioli e del modo di estrarre l'olio, e di altri vantaggi che si possono ottenere da' medesimi. Napoli, 1818. 8vo.
1817. *Landeschi, ———, parish priest of Saint Miniato.*  
Saggio di Agricoltura, con note di Antonio Becchi. Firenze. 8vo. fig.
1818. *Ferrario, G. A.*  
L'Agente in Campagna o sia regola sperimentata per migliorare i prodotti d' ogni genere d' Agricoltura secondo le terre del regno d' Italia; opera accomodata all' intelligenza de' contadini per loro maggior profitto. Milano. 8vo.
1818. *Giardi, Giuseppe.*  
Lezione proeniale d' Agricoltura pratica ragionata. Parma. 8vo.
1818. *Redolfi, Cosimo.*  
Memoria sopra un nuovo metodo per ottenere la farina di patate; sull' orzo, sull' acido muriatico, sulle zuppe economiche, e sulla ruggine del grano. Firen. 8vo.

#### SUBJECT. 4. *Of the Bibliography of the Agriculture of the other Countries of Europe.*

7115. *Germany and Britain* are the only countries in Europe in which it answers to print agricultural books for the sake of the indigenous readers. In Britain education is so general among the middling and lower orders, that reading among them is a necessary convenience of life: in Germany, education and reading are equally general and essential; and consequently in either of these two countries, a book will pay by its sale within the country. But this is not the case in any other European country. In France the mass of the people do not read, but books printed there pay because they are in a language more universal than any other, and perfectly understood by all men of education in Europe. Italian books pay, because they are enquired for by the agriculturists of the south of France, all Spain, and in part of Spanish America.

7116. *Spanish and Portuguese books on agriculture* are in much too limited a demand for production. The earliest Spanish author is Herrera in 1596; and there are scarcely half a dozen since. After the most particular researches of a book agent at Madrid, he was only able to send a list of translations, and the transactions of the Economical Society of Madrid, who have also published Herrera's work with notes within the present century. In 1815, a professor at Madrid published *Leiones de Agricultura explicadas en el Jardin Botanico*, 2 tomes, 4to. An anonymous author, *Disertaciones sobre varios Piantos Agronomicos*, 1 tom. 4to. Of Portuguese books we could hear of none.

7117. *Of Flemish and Dutch books on agriculture* there are scarcely any. These languages are very limited, and every reader in Holland or Flanders understands French or German. Many works have been published in the low countries in Latin and French, but these cannot be considered indigenous. The few Dutch works on culture belong almost all to gardening, (*Encyc. of Gar.* 7695.) The result of our correspondence with Amsterdam is a *Nieuwe Naamlijst van Boeken*, &c., from which we see little worth taking. There are several translations from British works on culture, and French veterinary books, and the following seem the latest on husbandry.

Magazijn van Vaderlandschen Landbouw, door J. Kops, Commissaris tot den Landbouw, 6 deelen compleet met register.  
Aanwijzing ter verbetering van de Akkerbouw en Landhuishoukunde, in de Nederlanden, door Professor A. Bruchasius, in 2 deelen.

De Boeren Goudmijn, of kunst, om van verschillende soorten van Landerijen, het meeste nut te trekken, meer Vee te kunnen houden, en andere Wetenswaardigheden tot den Landbouw, door J. F. Serurier en J. Kops, met platen.

7118. *Of Swedish and Danish books on agriculture*, there are necessarily very few; these languages being of very limited use, and the mass of the people too poor to be able to afford to read about ordinary matters, or what they consider as already well known to them. The time such a people give to reading will be devoted to religious subjects, heroic and romantic poetry, or history. The universities of

Stockholm and Upsal every one knows has produced some useful naturalists; some of these have written tracts on agricultural improvements, especially on planting fruit trees (*Frukt-Träd.*) and cultivating culinary vegetables (*Köchs-och Krydd.*) A few of such works we have enumerated in our Bibliography of Gardening (7096.), but we can scarcely find any fit to be inserted here as agricultural. *The Natural and Chemical Elements of Agriculture*, by Count Gustavus Adolphus Gyllenberg, a learned Swedish statesman, were translated by John Mills in 1770, and may be considered as the prototype of Davy's *Agricultural Chemistry*.

7119. *Of Polish and Russian books on agriculture* it may be easily conceived there are very few. Some translations from French works were made into the Polish language under Fred. Augustus II.; but few or none since that time; the German or French being universally understood by the reading class. Books of agriculture in the Russian language could be of little use. The only things printed in that way there are in the transactions of the Economical Society of Petersburg, by foreigners resident there, and in Latin or German. The best informed Russian nobles read French or German like the Poles. There is an agricultural society at Warsaw, who occasionally print their transactions.

#### SUBJECT. 5. *Agricultural Bibliography of North America.*

7120. There are a few American books of agriculture, and republications there of most of our best works on the subject. Dean's *New England Farmer's Dictionary*, and Dwight's *Travels*, may be considered as giving an idea of the husbandry of that part of the country; and Roughley's *Jamaica Planter*, of the agriculture of the West India Islands. A number of interesting papers on the subject will be found in the transactions of the American, New York, Philadelphia, and other societies.

1744. *Bartram, John, M.D.*, Philadelphia.

On the Salt Marsh Musell: On Oyster Banks and the Fresh Water Musell of Pennsylvania. (*Phil. Trans. Abr. ix. p. 70.*)

1754. *Fleming, or Fleming, Malcolm, M.D.*, of Brigg.

A Proposal in order to demonstrate the Progress of the Distemper among Horned Cattle: supported by Facts. York, 8vo.

1755. *Belgrove, William.*

A Treatise upon Husbandry and Planting. Boston, New England, 4to.

1764. *Elliott.*

Essays upon the Husbandry in New England. Lond. 4to.

1779. *Carver, Jonathan, Esq.*, born in America in 1732; died at London 1780, in great poverty.

A Treatise on the Culture of the Tobacco Plant, with the Manner in which it is usually cured, adapted to Northern Climates, and designed for the Use of Landholders of Great Britain, with two Plates of the Plant and its Flowers. Lond. 8vo.

1789. *Antill, Hon. Edward, Esq.*, of New Jersey.

1. An Essay on the Cultivation of the Vine, and the Making and Preserving of Wine, suited to the different Climates of North America. (*Americ. Trans. i. 181.*)

2. The Method of curing Figs; and Observations on the raising and dressing of Hemp. (*ib. l. 266.*)

1789. *Bartram, Moses.*

Observations on the Native Silk Worms of North America. (*American Trans. i. 294.*)

1789. *Carter, Landon*, of Sabine Hall, Virginia.

Observations concerning the Fly-weevil that destroys the Wheat; with some useful Discoveries and Conclusions. (*Trans. Americ. Soc. i. 274.*)

1790. *Dean, Dr.*

New England Farmer's Dictionary.

1800. *Destère.*

La Science du Cultivateur Americain: Ouvrage destiné aux Colons et aux Commerçans. 8vo.

1801. *Bordley, J. B.*

Essays and Notes on Husbandry and Rural Affairs. Philadelphia, 8vo.

1812. *Barton, Benjamin Smith, M.D.*, professor of natural history and botany in the university of Philadelphia.

On the Native Country of the Solanum Tuberosum, or Potatoe. (*Nic. Jour. xxxi. 290.*)

1823. *Roughley, Thomas*, nearly twenty years a sugar planter in Jamaica.

The Jamaica Planter's Guide; or, a System for Planting and Managing a Sugar Estate, or other Plantations in that Island, and throughout the British West Indies in general. Illustrated with interesting Anecdotes. 8vo.

*Higgins, Jesse*, of Delaware.

A Method of Draining Ponds in Level Grounds. (*Trans. Americ. Soc. vol. 3. p. 325.*)

*Greenway, Dr. James*, of Dinwiddie County, in Virginia.

Of the Beneficial Effects of the Cassia Chamæcrista, in recruiting worn-out Lands, and enriching such as are naturally Poor. (*Trans. Americ. Soc. iii. p. 226.*)

#### CHAP. V.

##### *Of the Professional Police and Public Laws relative to Agriculturists and Agriculture.*

7121. *By Professional Police*, we mean those associations which agriculturists have formed at different times and in different manners for mutual benefit or instruction; and also those institutions for the same purpose established by the legislature, or of such a nature as to be considered public, or national: by laws we allude to those special legislative enactments which affect more particularly agriculture; these are so numerous that we must refer the reader to his lawyer or law dictionary.

7122. There are few or no *agricultural lodges*, of the nature of those of masonry or gardening. In Scotland it would appear something of this kind had existed among ploughmen at one time, as the passwords and initial ceremonies are talked of in some of the counties by old men. In Forfar, Kincardine, Banff, &c. it is not uncommon for ploughmen, as well as various descriptions of operatives, to belong to gardener's lodges. In the southern districts where sheep farming is followed, there are some shepherd's societies for mutual interchange of experience, and aid in case of losses of such sheep as are the shepherd's perquisite: there are some ploughmen's clubs in different places, and various associations among them of the nature of benefit societies, but these do not come under the description of professional.

7123. *Agricultural societies* for interchange of knowledge are of modern date, but they have increased rapidly since 1794; the number at present or lately existing in the British isles, is at least equal to the number of the counties. Societies of this description

are either general, as the board of agriculture and society of arts; national, as the Highland society and Dublin institution; particular, as the Bath and West of England society; provincial, as county societies; and parochial, as being limited to a few individuals within one parish; of this kind are farmer's clubs, ploughing societies, &c. In regard to the end in view, these societies either embrace the arts in general, the rural arts in general, or some branch of the rural art, as agriculture; or some department in that branch, as live stock, sheep, wool, &c.

7124. All these societies hold meetings at stated periods; most of them offer premiums for particular objects, — specimens of vegetable or animal culture or produce — agricultural operations, — moral and professional merits, as servants, &c.; and some of them form a library and museum of models or full sized implements—a few publish transactions, and one or two, as the Dublin society, send out itinerant ploughmen and agricultural mechanics to instruct practical farmers. These societies are almost wholly supported, and the fund for premiums raised by the subscriptions of members, and by voluntary donations, legacies, &c.; but some, as the board of agriculture and the Dublin society, have received assistance from government.

7125. *Of English agricultural societies* the oldest is the society of arts founded in 1754, by Lord Folkstone, Lord Romney, Dr. Hales, and Shepley. They have published many volumes of transactions, awarded immense sums in premiums, and, on the whole, done much good. (See *Rees's Cyc. art. Society.*)

7126. *The Bath and West of England society* was founded in 1777, for purposes similar to those of the London society of arts: they have published some valuable volumes of transactions, and distributed various rewards, &c. (*Rees's Cyc. &c.*)

7127. *The board of agriculture* was founded under the authority of government about 1793; much was expected from this board, but, excepting the publication of the county reports, and the general attention which it called to agriculture, it may well be asked what advantages arose from it. Their *Communications*, in several quarto volumes, contain fewer valuable papers in proportion to their total number than either the London society of arts, or the Bath societies publications; in short, it has been ably shewn in *The Farmer's Magazine*, and the article *agriculture* in the supplement to the *Encyc. Brit.*, that the board never directed its efforts in a manner suitable to its powers and consequence; and that instead of discussing modes of culture, its attention ought to have been directed to the removal of the political obstacles to agriculture, and to the eliciting of agricultural talent by honorary rewards, &c. No idea is more erroneous than that of such a board, or any other doing much good by a national "experimental farm." Horticulture is much better adapted for improvement in this way than agriculture, but a few years will shew whether the immense garden of the London Horticultural Society will answer the expectation of the subscribers.

7128. *Of Welsh societies* there are only two or three of inferior note, which have been already noticed in the topography of the country.

7129. *Of Scotch societies* the principal now existing are the Highland society and the Dalkeith farming society.

7130. *The Highland society* of Scotland was established in 1785, to enquire into the state of the Highlands, to consider the means of their improvement, and the preservation of their language; it is chiefly supported by the subscriptions of its members at a guinea each, a year, and a grant of 3000*l.* from government, soon after its establishment. It has published 5 vols. of prize essays and papers, and now extends its prizes to all the low counties of Scotland. (*Farm. Mag.* vol. 16—316.)

7131. *Of Irish societies* the principal are the Dublin society and the Cork institution.

7132. *The Dublin society* was established in 1731, and incorporated in 1749. Arthur Young observes, that it was the parent of all the similar societies now existing in Europe; but the Edinburgh agricultural society, as we have seen, (775. and 801.) was established nearly ten years before. The Dublin society, in its present advanced state, is one of the most complete establishments of the kind that exists. (*Rees's Cyc. art. Dublin.*)

7133. *The farming society of Ireland* was established under the patronage of the Dublin society in 1800. The object is to improve the agriculture and live stock of the kingdom. (*Archer's Dublin*, 160.)

7134. *The Cork institution*, for applying science to the common purposes of life, originated in private subscriptions about the beginning of the present century; it has since been incorporated, and received the assistance of government, has a house, large botanic garden, and under its auspices are delivered lectures on chemistry, botany, agriculture, &c.; it is not, however, in a flourishing state, and has never been of much use.

7135. The principal county societies in the three kingdoms have been noticed in the topography of agriculture: many of them were established several years before the board of agriculture.

7136. The only other institutions for the improvement of agriculturists and agriculture are public professorships: of these there is one in the university of Edinburgh, established



in 1795; one in Dublin, supported by the Dublin society; one in Cork, and one is destined to be established at some future period in Oxford, agreeably to the will and donation of Dr. Sibthorpe (7004.), professor of botany there.

---

## BOOK II.

### OF THE FUTURE PROGRESS OF AGRICULTURE IN BRITAIN.

7137. *The improvement of agriculture*, like that of every art, manufacture, or commodity, necessarily depends on demand and production: a powerful or effectual demand will ensure produce, and excellent produce will, to a certain extent, create demand. A general nicety of taste in coach or saddle horses will call forth a superior description of these animals, and superior animals will tempt purchasers; if the inhabitants of any district who live chiefly on barley or oats, indicate a preference for wheat, and a willingness to pay for that grain, wheat will be produced, and so on. Again, as the object of every individual who engages in art or trade, is to acquire gain, the advancement of an art will depend mainly on the profits it affords; an art or occupation which affords less than the average profits on capital, will only be followed by such as, from habit or other reasons, cannot apply themselves to any thing better, but extra profits will command both capital and skill. From these considerations it is obvious that the improvement of agriculture depends on the profits on capital employed in it, on the taste of those who purchase its products, and on the knowledge of those who are engaged in agriculture as a profession. The first subject would lead us further into political economy than would be of much use in a work of this kind, and therefore we shall limit ourselves to a few remarks on the other topics.

---

### CHAP. I.

#### *Of the Improvement of Agriculture by refining the Taste of the Purchasers of its Products, and increasing the Knowledge of Agricultural Patrons.*

7138. *The desire of being comfortable* is the first step towards improvement; but before any thing can be desired, we must know what it is. Men rest satisfied with what they have when they know of nothing better, and therefore one of the main sources of improving the taste both of those who purchase agricultural produce from necessity, and those patrons of agriculture who purchase jointly from necessity and choice, is the increase of knowledge. Could a taste for wheaten bread and butcher meat be introduced generally among the operative classes in Scotland and Ireland, the advantages to agriculture would be immense. Could the same persons be taught to desire a greater degree of cleanliness, light and warmth in their cottages, a greater variety of potherbs, salads, fruits, and flowers in their gardens, and handsome dresses for their wives and daughters; how great the general benefit! Much may be done to bring about this change, by the opulent who are willing to reside on their estates and to take a little trouble. Building good and comfortable cottages, and attaching proper gardens, and stocking them with trees and plants from the demesne garden; offering little premiums, or marks of distinction for keeping them in the nicest order, and for decently clothed, well-bred children, would soon have a sensible effect; attending to that kind of education which consists in teaching infants civility and politeness, with mutual respect and restraint as occasion requires; and teaching grown children how to work at almost every thing likely to come in their way, as is done in the improved German and Swiss schools, would, independently of reading and writing, do a great deal to soften and humanize the peasant mind. Encouragement should be given to save money for unforseen wants, or age; and the certain effects pointed out of early marriages, followed by numerous offspring. These and a variety of similar means would be productive of some change of taste in the operative part of rural society.

7139. *The introduction of manufacturing establishments*, wherever it could be properly done, would contribute to the same effect: those who work at manufactures, and even common mechanics, generally live better, and are better clothed and lodged than the common country laborer; therefore their example would be of use in introducing a salutary degree of luxury. "The endeavoring to impress on the minds of the lower

classes, the propriety of being contented with the simplest and cheapest fare, is extremely pernicious to the best interests of mankind. Encomiums ought not to be bestowed on those who are contented with mere necessities: on the contrary, such indifference ought to be held disgraceful. A taste for the comforts, the enjoyments, and even the luxuries of life, should be as widely diffused as possible, and if possible, interwoven with the national character and prejudices. This, as it appears to us, is the best mode of attempting the amelioration of the condition of the lower classes. Luxuries, and if you will have it so, even wasteful habits, are incomparably better than that cold, sluggish apathy, which would content itself with what can barely continue mere animal existence." "In those countries," Ricardo judiciously observes, "where the laboring classes have the fewest wants, and are contented with the cheapest food, the people are exposed to the greatest vicissitudes and miseries: they have no place of refuge from calamity; they cannot seek safety in a lower station; they are already so low that they can fall no lower. On any deficiency of the chief article of their subsistence, there are few substitutes of which they can avail themselves, and dearth to them is attended with almost all the evils of famine." (*Sup. Encyc. Brit. art. Corn Laws.*) Such is the case in Ireland, where amidst the germs of the greatest riches and luxury, the inhabitants are contented to live on less than any other people in the world.

7140. *The taste of the superior patrons of agriculture is to be improved by visiting the best cultivated districts, reading agricultural works, attending agricultural societies, and, above all, by cultivating a farm, and establishing on it a systematic order and regularity in every detail.* Let such observe the hedges, gates, verges of fields, and the beautiful rows of turnips, of Berwickshire or Northumberland; the correctly drilled beans of East Lothian, and the live stock of Leicestershire. But few are the proprietors of lands who either employ a proper bailiff or demesne steward; and of those who do, how few who do not limit and fetter them in their operations, or else neglect them and leave them to sink into that supine state in which the uppermost wish is to enjoy the comforts of the situation with the least possible degree of exertion! Some proprietors desire to have their home farm managed with a view to profit, as the cheapest way of getting hay, straw, mutton, &c.; these are sordid patrons: a home farm ought to combine an elegant orderly style of management, high kept horses, harness, implements, &c., well clothed servants, and every thing in a superior style to what is seen on common farms. Particular attention ought to be paid to the buildings, which ought to combine architectural design, fitness, strength, and elegance; the roads ought to be like approaches to a mansion; the hedges like those of gardens, and the green verges round the fields kept mown like lawns or grass walks, and the ditches, bridges, and gates in corresponding neatness; the finest trees ought to be encouraged in proper situations, and correctly pruned, and substantial watering places formed and kept supplied. Every operation on plants, or the ground, performed in a garden-like manner, and no individual of any species of stock kept, of which a drawing might not be taken and preserved as a beauty. Even the dress and deportment of the servants on such a farm ought to harmonize with the rich culture, orderly display, and high keeping of the whole.

---

## CHAP. II.

### *On the Improvement of Agriculture by the better Education of those who are engaged in it as a Profession.*

7141. *By education is generally understood that portion of knowledge which is obtained at schools; but in a more extended sense (as Mills observes) it may be defined the means which may be employed to render man competent for performing the part which he undertakes to perform in life with increased satisfaction to himself and others. Education may thus be considered as extending to every thing which operates on the body or mind, from the earliest periods of our existence to the final extinction of life. It is unnecessary here to embrace the subject in its full extent, but we shall offer some remarks on the education of practical men in general, on the professional education of an agriculturist, and the general conduct and economy of his life.*

#### SECT. I. *On the Degree of Knowledge which may be attained by Practical Men, and on the general Powers of the human Mind as to Attainments.*

7142. *The knowledge of languages, history, geography, arts, sciences, and literature, which an agriculturist, whether a ploughman, shepherd, bailiff, steward, or rent-paying*

farmer, daily occupied with his<sup>n</sup> profession, may acquire, provided he begins at the earliest moment, say at fifteen years of age, and continues to employ his leisure hours in reading till he is twenty or twenty-five, is by no means inconsiderable; not that he can or need become learned; but, if desirous, he may become generally intelligent, render himself fit, as far as conversation is concerned, for good society, prove instructive and entertaining to others by his conversation, and provide a reserve fund of enjoyment, by laying up a store of ideas for reflection in misfortune, disease, or old age.

7143. *The utility of knowledge* to that part of mankind who are doomed to a life of mechanical labor, or rather who suffer themselves to be doomed to it, has been questioned; it is said to render them dissatisfied with their condition, to produce various other evils, and at all events in no way to add to their happiness or the good of society. To a man whose business in life is the mere mechanical performance of operations which any other animal might perform if furnished with hands, education is doubtless less necessary, than to a man whose business is to direct the operations of others; but it does not follow, that though less necessary, it may not be highly useful: if, for example, it renders him dissatisfied with his condition, it will, at the same time, be more likely than any thing else to lead him to some proper mode of improving it; or if almost unimprovable, education certainly will be more likely than a state of ignorance to teach patience and submission, by enabling him to reflect on the folly of grieving at what is inevitable, and the consequences of committing what is unjust or criminal to relieve himself. "The low Irish," Marshal remarks, "are sufficiently dissatisfied with their condition; those who know how to alleviate it by emigration, go to Britain or America; those who know nothing, stay at home, commit acts of violence, and are hanged."

7144. *To decide as to the utility of knowledge to the operative parts of society* would perhaps require a previous decision of the question, "what constitutes happiness?" The general answer is, the exercise of all our faculties of body and mind; every one who has lived thirty or forty years in the world, knows that there is no such thing as absolute happiness: the prince de Ligne, a man of great natural parts, with every advantage of person, birth, and wealth, and in favor at all the courts of Europe; fond alike of war, literature, gallantry, and agriculture, and who lived to be upwards of 90 years of age, has left on record that he was only perfectly happy two or three times in his life, and only for a few minutes each time. Forsyth (*Principles of Moral Science*, vol. i. chap. 1.) says, happiness is a thing not to be thought of, and all that men and women can do in order to make the most of their existence, is to occupy themselves and make progress in whatever they engage in; progress in enjoyment, or approximation to happiness may therefore be obtained.

7145. *The utility of knowledge to every human being* is consequently, in our opinion, unquestionable, on the mere principle of adding to enjoyment; nor do we believe that there is more danger from excess of knowledge in any particular class of society, high or low, than there is from excess in their eating or drinking. A number of men possessed of property or power by inheritance, favor, or chance, who are very conscious that they never could have acquired those advantages by the common competition of talent and industry, and who are in fact wrapt up in selfishness, are naturally jealous of the progress of knowledge; their secret maxim is to keep down the lower orders, and to impress on their minds only the duties of loyalty, religion, and, as Vancouver adds, hard work. This monopoly of power and knowledge, however, cannot be maintained for ever, and in every country is found rapidly yielding to the general progress of society. It is only those who have to dread this progress that fear the diffusion of education and liberal principles.

7146. The terms *knowledge and ignorance are entirely relative*: the knowledge of a modern chemist's porter would have subjected him to be hanged and burned in the days of the first popes; and any bricklayer's laborer of the present day who reads the London newspapers, has more correct ideas of the principles of political economy, than nine-tenths of the nobility in Russia and Spain. It is impossible to set limits to the knowledge which may be obtained by those who are destined even to the most severe and constant labor; the intelligence of the miners in Scotland and Sweden may be referred to as proofs. The miners at Leadhills have a regular library and reading society, and the works they make choice of are not only histories, voyages, travels, &c. but even works of taste, such as the British classics, and best novels and romances. The degree to which knowledge will prevail among any class of laboring men, will depend jointly on their own ambition; on the demand for or reputation in which knowledge is held, and on the opportunities of acquiring it. A dull, stupid person, with little native activity, will never desire to know more than what enables him to supply the ordinary wants of life; but where the workmen of any art are required to have technical knowledge of any particular kind, they will be found invariably to possess it. Thus carpenters and masons require some knowledge of the mechanical principles of

architecture, and working engineers of the strength of materials; and these kinds of knowledge are acquired by them without an hour's interruption of their daily labor; on the contrary, the habit of evening study renders them more steady, sober, and industrious than other workmen; than bricklayers and paper hangers, for example, whose employments require much less intellectual skill. If every cook-maid, before she could obtain a first-rate place, were required to be able to read *Apicius Redivivus* in the original tongue, there would be no want of learned cooks; and if no bailiff could obtain a first-rate situation who had not written a thesis in Greek, or who had not made the tour of Europe, there would soon be found abundance of bailiffs so qualified. A Caledonian, when he comes to the low country, soon acquires the English tongue, and if he has been taught latin, thus knows three languages. The servants at the inns on some parts of the continent, frequented by different nations, often acquire a moderate knowledge of three or four languages: a late custom-house officer on the island of Constatd, spoke and wrote ten languages; and the bar-maid at the hotel de Londres, at which we lodged in Moscow, in 1814, could make herself intelligible in Swedish, Russian, Polish, German, French, Italian, and English.

7147. *The certain way of obtaining anything*, is to be impressed with the necessity of possessing it, either to avoid the evil of being without it, to satisfy the desires of others as to ourselves, or our own desires. There is scarcely any thing that a rational man can desire that he may not obtain, by maintaining on his mind a powerful impression of the necessity of obtaining it; pursuing the means of attainment with unceasing perseverance, and keeping alive that enthusiasm and ardor which always accompany powerful desires. All may not acquire by the same degree of labor, the same degree of eminence; but any man by labor may attain a knowledge of all that is already known on any subject, and that degree of knowledge is respectable; what many never attain to, and what few go beyond.

7148. *The grand drawback to every kind of improvement* is, the vulgar and degrading idea that certain things are beyond our reach; whereas the truth is, every thing is attainable by the employment of means; and nothing, not even the knowledge of a common laborer, without it: there are many things, which it is not desirable to wish for, and which are only desired by men of extraordinary minds; but let no man fancy any thing is impossible to him, for this is the bane of all improvement. Let no young ploughman, therefore, who reads this, even if he can but barely read, imagine that he may not become eminent in any of the pursuits of life or departments of knowledge, much less in that of his profession: let him never lose sight of this principle—that to desire and apply is to attain, and that the attainment will be in proportion to the application.

## SECT. II. *Of the Professional Education of Agriculturists.*

7149. In order that a *professional man should excel as such*, every other acquirement must be kept subservient to that of his profession. No branch of knowledge should be pursued to any extent that, either of itself, or by the habits of thinking to which it gives rise, tends to divert the mind from the main object of pursuit; something, it is true, is due to relaxation in every species of acquirement; but judicious relaxation only serves to whet the appetite for the vigorous pursuit of the main object. By the professional education of agriculturists, we mean that direction of their faculties by which they will best acquire the science and manual operations of agriculture, and we shall suppose agricultural pupils generally, to have no other scholastic education than some knowledge of reading, writing, and arithmetic.

7150. *All young men who intend embracing agriculture as a profession*, whether as ploughmen, bailiffs, stewards, land valuers, or rent-paying farmers, ought to undergo a course of manual labor for one or more years, in order to acquire the mechanism of all agricultural operations: when the pupil is not destined for any particular county, then he should be sent to a farmer in a district of mixed agriculture; as for example, East Lothian, where he would, if placed in a wheat and bean culture farm, see at no great distance the turnip system and feeding, and a few miles off; the mountain sheep-farming or breeding; when the pupil is intended to be settled in any particular county, he ought to be sent to a county as near as possible of similar soil and climate, where the best practices are in use, as from all the turnip counties, pupils should go to Northumberland or Berwickshire; from the clay counties to East Lothian, or the carse of Gowrie; from a mountainous district to the Cheviot hills, and Tweedale, &c.

7151. *The term of apprenticeship* completed, the future time of the pupil ought to be regulated according to the ultimate object in view: if he is intended as a ploughman, shepherd, or hedger, perhaps to introduce new practices in other counties, he may remain for a year or two longer with other masters in the same district, in order not

merely to acquire but to habituate himself to all the improved operations and practices. If he is intended for a bailiff, then, after having been two years in one character of farm, let him engage himself for a second two years in a district of an opposite or at least of a different character; and for a third two years, on a third character. There are, as already shewn, only three different descriptions of farming in Britain; the bean and clover, or clay land farming, which includes feeding, by soiling; the turnip farming, which includes feeding both by soiling and pasturage; and the hill, or mountain, or pasture farming, which includes all the varieties of breeding. A young man therefore of ordinary intellect, who has worked two years in East Lothian on a clay farm, two years in the lower Berwickshire, or in the low part of Northumberland, and two years on the Northumbrian hills, must have a very competent knowledge of that part of agriculture, known as farming or husbandry.

7152. *The higher branches of agriculture, or what may be called the engineering, valuing, and estate agency departments, can only be completely acquired by first going through the course above described, as suitable for bailiffs and common stewards, and next, placing themselves under an eminent steward, land valuator, drainer, road engineer, irrigator, &c. as the case may be: making choice of a steward who has extensive woods and plantations, and also, if possible, some quarries, fisheries, or even mines under his care, and of a land valuer or drainer in full employment.* When a solid foundation is laid, by a thorough practical knowledge, of all the operations of common agriculture, the higher part is attained with ease, and may be practised with confidence; but, on the contrary, when young men who know nothing of common country work are sent direct from school, or from an attorney's office, to a land steward or agent, in order to acquire the art of managing landed estates, the worst consequences may be dreaded, both to the proprietors and the occupiers of the territory which may be subjected to them. The condition of many estates and tenants, managed by attorneys, may be referred to in proof of our assertion.

7153. *Young men intended as rent-paying farmers, after two years' labor as common servants, should be kept as assistant bailiffs on other farms, till they are at least 25 years of age: no young man, in our opinion, ought to be put in a farm on his own account, or employed as a master bailiff, at an earlier period.*

7154. *In all cases when young men are destined for particular purposes, they should be sent chiefly to particular districts; as for example, young men intended for road-surveyors, to where roads are best managed—drainers to a draining country—embankers to Lincolnshire—warpers to the Humber—irrigators to South Cerney—hedgers to Berwickshire—woodmen and foresters to Dunkeld, or Blair, Athol, &c. It would contribute much to the improvement of agriculture in the backward counties, if landed gentlemen would prevail on their tenants to send their sons as apprentices, or even as ploughmen, or farm laborers, to the improved counties; or where there are lads brought up by the parish, to send them there with a view to their acquiring the use of the improved implements.*

7155. *Whatever be the kind of professional knowledge to be acquired, the means of attainment is the pupil's paying such attention to what he sees and hears as to fix it in his memory. One of the first things, therefore, that a young man should do, is to cultivate the faculty of attention, which he may do every hour of the day, by first looking at an object and then shutting his eyes, and trying whether he recollects its magnitude, form, color, &c.; whether he would know it when he saw it again, and by what special mark or marks he would know it or describe it. When he goes from one part of the farm to another, or is on a walk or journey, let him pay that degree of attention to every thing he sees and hears, which will enable him to give some account of them when returned from his walk or journey; and let him try next day, or some days afterwards, if he can recollect what he had seen then, or at any particular time and place.*

7156. *The attention to be exercised in such a way as to impress the memory, and enable the observer or hearer, not only to recollect objects, but to describe them, must be exercised systematically. A thing or a discourse must be attended to, not only as a whole, but as a composition of parts, and these parts must be considered not only as to their qualities of dimension, color, consistency, &c. but as to their relative situation and position. To be able to give an account of a town or village, for example, the first thing is to get a general idea of the outline of its ground-plan, which may be done by looking from a church tower, or adjoining hill; next, its relative situation to surrounding objects, as what hills, or woods, or waters join it, and in what quarters; next, the direction of the leading street or streets must be noticed; then the intersecting or secondary streets, the principal public buildings, the principal private ones, where the lowest houses and narrowest streets are situated, and what is the character of the greater number of houses composing the whole assemblage.*

7157. *To treasure up in the mind the characteristic marks of particular varieties and subvarieties of stock is a most important part of an agriculturist's professional education.*

To do this effectually, some knowledge of sketching is of great use, and, if possible, ought to be acquired by every person intending to fill the situation of bailiff or steward. The knowledge of soils, plants, and their culture, is a very simple business compared with the knowledge of stock, which is not only of difficult and tedious acquirement but easily forgotten or lost: for one gentleman's bailiff that knows any thing of stock there are at least a score that know nothing.

7158. *In connection with professional studies*, the pupil may find it necessary, if his education has been neglected, to go on at his leisure hours with all the usual branches of education, either assisted by books alone, or by books and the best assistance he can procure. If his school education has extended to arithmetic, mensuration, mathematics, and drawing, he should occupy himself in acquiring a knowledge of botany, zoology, geology, and mineralogy, without a tolerable knowledge of each of which, he will ever be in the dark among modern agriculturists, and in reading books on the subject. Next, let him study the various arts and manufactures that have any relation to agriculture, and store his mind with all he can acquire from one of the best general *Encyclopædias*, as that of Rees, or the *Encyclopædia Britannica*, with its excellent supplementary volumes. If he will go farther, and if he wishes to know the extent to which he may go, he may consult what we have advanced on the subject of education in the *Encyclopædia of Gardening*.

### SECT. III. *Of the Conduct and Economy of an Agriculturist's Life.*

7159. *A plan for the general conduct of life* should be fixed on by every one when he arrives at manhood, and steadily pursued for the time to come: most commonly such a plan is formed by the parents soon after the child's birth, and at the latest, when the boy is taken from school. The boy arrived at manhood, however, is entitled to examine this plan, and amend it, or devise another more congenial to his own notions; but the risk of any change of this sort by persons so young and inexperienced is so great, that no youth ought to venture on it without the utmost consideration and the firmest persuasion in his own mind: where the parent has done his duty, such changes of plan will not often be attempted, for, by the early infusion into the mind of a child, ideas of the pursuit that is intended for him, a taste for that pursuit or employment will grow up with him, and become as it were his own natural inclination. This will happen in most cases, but in some children the bias or force of nature for some particular purpose is so strong, that by no parental intreaties or reasoning can it be overcome; even where a sense of duty has induced compliance with a parent's wishes for a time, the dormant inclination has at last broke out and taken the lead. In such cases, the parent may generally conclude, that where the pursuit or purpose is not bad, the force of natural inclination will be more likely to command success than the influence of parental authority, and that a pursuit or business, commonly of little profit or repute, will be more profitable and respectable when followed by a genius powerfully impelled to it, than a profitable and reputable business followed by any one against their inclination.

7160. *The plan and conduct of life is in most cases determined by accidental circumstances.* The son of the laboring man grows up without any regular training or education for a particular end, and finds himself at the age of manhood engaged in rural labor, and apparently incapable of any other; his notions and his ambition are so limited that he dare not venture to desire a change for the better, for no man ever desires that which he thinks impossible to attain, and the mere idea of this impossibility, however erroneous, effectually restrains the attempt at improvement. The life of the ploughman or laborer, much as it differs from that of a man of eminent natural powers and superior education, is capable of much amelioration by being directed to a suitable end or object as the ultimatum, or in other words, by proceeding on a plan; plan indeed, as we have elsewhere observed, (*Encyc of Gard.* 2nd edit. 7778.) is predestination, as conduct is fate.

7161. *The greater part of mankind enter on life without any fixed plan or object in view*, or if they form some general notion of acquiring wealth or distinction, they form no plan by which it is to be accomplished; and the consequence is, that such persons after blundering on through their best years, arrive at the end without having gained anything but experience, now of no use to them. No man is born in possession of the art of living, any more than of the art of agriculture; the one requires to be studied as well as the other, and a man can no more expect permanent satisfaction from actions performed at random, than he can expect a good crop from seeds sown without due regard to soil and season: when we look round and observe the quantity of misery in the world, the greater proportion is, or seems to be, the result of a want of plan, or of a bad plan of life: how many parents are unsuccessful in their struggles to maintain a large family, the result of too early marriages: how many find themselves arrive at old age with no other resource for support but charity, the consequence of want of foresight in expenditure: how many are suffering under poverty, brought on by their own want of frugality, or positive extravagance; or under disease from excesses and irregularities committed in the hey-day of life: and how many among those not born to inherit property, who, at no period of their life, have any other alternative between hard labor and deficient food, than disease and want.

7162. *Want of plan may not in every case be the cause of all this misery*, because, accident enters into life for something, both in the unfavorable as well as the favorable side of the question; but we have no hesitation in asserting, that want of plan, as a cause of misery, is as ninety-nine to a hundred: any plan at all, even a bad plan, is better than none, because those who set out on any plan will, in all probability, sooner discover its errors, if a bad one, and correct them, than those who set out on no plan, will discover the want of one, and form a good plan. The young man who is just setting out in life, may well tremble at the consequences of proceeding on the journey without the guide of a judicious plan; this plan he must form himself, because he alone feels what he wants, and what he can do to gratify them;—all that we can do is to offer a few hints.

7163. *In order to be able to form a plan it is previously necessary to determine the object to be attained*

by it : happiness is the object of every action of human life, and consists in the gratification of certain wants and desires ; some of these desiderata are peculiar to youth, and others to old age, but many, as clothing, food, rest, relaxation, entertainment, &c., begin with the earliest, and continue to the latest period of life : all these gratifications are procured by labor ; in savage life, by hunting, fishing, and gathering fruits, till the man, no longer able for these labors, is obliged to lie down and die of want : in civilized society, they are also obtained by labor ; but here, what is called property, exists, and man, in the vigor of his days, when the supplies of his labor are greater than the demands of his wants and desires, or when he chooses not to gratify the latter to the full extent admitted by the former, can, as it were, embody a part of his labor, to be made use of when he is no longer able to perform it with ease : a man in this case is said to arrive at independence, instead of want, as in the case of the savage ; or of beggary, as in the case of the improvident.

7164. *Independence is the grand object* which every man destined to live by the exercise of his labor or talents ought to have in view. At certain periods of life, when the imagination is vivid, and health and spirits in their utmost vigor, some may prefer present enjoyment, mere animal gratifications, or imaginary distinctions, amatory conquests, titles, rank, military glory, high literary or professional reputation : it is a noble attribute of our nature to prefer these to mere accumulation of money ; but a great warrior, poet, or painter, arrived at old age and want, if the latter be brought on by common improvidence, will not find himself surrounded by many marks of distinction ; and though it may possibly be some consolation to him that the three or four letters composing his name, will be sometimes pronounced together after he is dead, yet it will not be much.

7165. *The exercise of his profession is the most rational mode* in which an agriculturist, of whatever grade, can pursue independence ; only extraordinary circumstances can justify a change of profession ; in common cases it indicates a want of steadiness of character, or a want of success, and the latter is commonly attributed to want of skill ; it is better, therefore, to pursue unremittingly the profession to which we have been educated, even though we should not be very successful in it, than to risk an infringement on character by adopting another. The practice of agriculture, as we have already seen, (6925.) is carried on by three different classes, serving, commercial, and artist agriculturists : on each of these classes we submit a few hints to aid them in forming a plan of life, and regulating their expectations.

7166. *The greater number of agriculturists must ever belong to the lower grades of the serving class ;* and act as ploughmen, herdsmen, shepherds, hedgers, woodmen, and laborers of all work. These form the greater proportion of mankind in every civilized country, and must ever remain the bulkiest material in the social fabric. Comparing one age and country with another, however, there may be the greatest difference in their intellectual and physical condition. The ploughman of Russia is but a remove from his horse. The ploughmen in different parts of Britain are as intelligent as their employers : in Scotland they have the Bible by heart, are familiar with the history of their country, and not ignorant of its literature : they lead a laborious life, but they enjoy the inestimable blessings of health, sound sleep, and peace of mind, till the latest period ; they are almost always independent, either from their labor, their savings, or in old age or sickness, from the assistance they receive of their children in return for what was laid out on their education. These men are as happy relatively to their capacity for happiness as any other class whatever ; if their measure is smaller, it is as full as the largest ; for the essential materials of comfort and happiness are the same in all classes, and in all classes a man's wants and wishes accommodate themselves to the means of gratifying them. The rich have no wants, and their desires, for the most part, are no sooner expressed than gratified ; the pains and pleasures of life are neutralized into a kind of insipidity, till ennui brings on disease, which to this class becomes a blessing, by procuring for them the occupation of taking medicine, the duty of attending to the doctor's regulations, and the pleasures of convalescence.

7167. *The plan of life suitable for the operative agriculturist* may very well be founded on the condition of this class of men in the northern counties of Northumberland, Berwickshire, East Lothian, and others. We have already (7048. and 7049.) described the manner in which farm servants are hired, lodged, and paid in these counties : the essence of the mode consists in the employer providing the employed with comfortable cottages and gardens, and paying them chiefly in the necessaries of life, in so much meal or flour, so much ground to grow potatoes, and flax or hemp, a cow's keep, the run of a pig—if a shepherd, so much wool, or so many sheep, the loan of a team to bring home coal or other fuel, and a certain proportion of money. By this mode of payment the operative countryman is always sure of a comfortable home and food, sure of milk, butter, meal, bread, and potatoes, the produce of a pig, poultry, and bees, and of the produce of his garden ; and this, however high may be the prices of these articles in the public market. All country servants hired by the year might be accommodated and paid more or less in this manner ; and to this mode of life and payment they ought to look forward as the ultimatum of their grade in the scale of operative agriculturists. By prudent conduct, in regard to the increase of their family, and by frugality, they may live in decency and comfort, educate one or two children, and save something for old age, or unforeseen occurrences.

7168. *The day laborer who has no particular employer,* and probably no fixed residence, is much less comfortable than the yearly servant ; in England more especially, under the present system of poor laws and parish management, which is calculated to degrade him, and effectually to prevent any attempt at improving his condition. If, as Slaney observes, "by unremitted industry, he has been enabled to do without parochial relief, and bring up his children decently, it is as much as could be expected ; for an attack of illness, or the temporary loss of employment, he is in general totally unprepared ; he thinks not much of the morrow, and, as it stands, it is perhaps well for him that he does not anticipate evils which he cannot prevent : every one knows how beneficial to the community, how advantageous to the indi-

vidual, the hope of bettering his condition in life is: it cheers him in adversity, encourages his industry, promotes his content, yet from this hope the major part of the agricultural laborers of England are excluded; they toil indeed, but it is to continue, not to better their existence." (*Essay on the beneficial direction of rural expenditure*, p. 170.; see also the succeeding chapters of these judicious and intelligent essays.)

7169. *The plan of life for the directive class of agriculturists* need hardly be pointed out; the rise from a farm bailiff to a steward's bailiff, or to a demesne bailiff or steward, and thence to the general steward or factor of an estate, is an obvious object of ambition. In another direction he may rise through the different gradations of the commercial agriculturist, or, adopting the rank of counsellor or artist, he may become a salesman, appraiser, timber or land-surveyor, land-valuer, agent, or agricultural engineer: rarely, however, can he attempt the veterinary profession, or those of draftsman, author, or professor.

7170. *The remuneration to which a directive agriculturist is naturally entitled*, should be regulated by his professional abilities and experience; that which he will commonly receive will be regulated by the quantity of agricultural talent and experience in the market; it ought always to be such as will preserve him in a distinct class from the operatives, and render it worth his while to be honest, assiduously attentive to the interest of his employer, and of a polite and obliging manner. A handsome salary to such a servant is wise economy.

7171. *The object of the artist or counsellor agriculturist*, may be either to ascend to the rank of author or professor, conditions of more honor than profit; or to realize property and become a proprietor cultivator. For a rent-paying farmer, no artist or author is at all adapted.

7172. *The legitimate object of a commercial agriculturist* is to rise in the different grades of his class, and become either a large farmer, a gentleman farmer, or, best of all, a yeoman, or proprietor cultivator (*proprietaire cultivateur*).

7173. *The profits to which a commercial agriculturist is entitled*, comparatively to that of other commercial men, are theoretically determinable by the risk attending the employment of his capital, and the skill requisite to prosecute his art; but practically, this remuneration will depend on the quantity of skill and capital in the market. The risk attending capital employed in the culture of the useful products of the soil, is evidently less than the risk of capital employed in many or perhaps most manufactures; and the skill requisite to enable any one to become a farmer, according to the customary practices of the country surrounding him, is less than that required for almost any branch of manufacture. In consequence of these things, there are men every where ready to become farmers; hence the profits of farming are naturally less than those of most other pursuits; but to counterbalance this, the farmer has several advantages peculiar to his profession. First, from the nature of his residence in the country, which assumes a certain degree of consequence, from its connection with a considerable group of out-offices; these, surrounded by a garden, orchard, fields, woods, and other rural scenery, all in his occupation, and inhabited by servants in cottages, horses, cattle, sheep, and other domestic animals, all in subjection to him; all these things give him a degree of consequence both real and apparent, and assimilate him more nearly to a lord of the soil, and to that sort of rural retirement and independence, the object of almost every commercial man's ambition, than any other mode of life short of the thing itself. Secondly, many trades and professions preclude (according to general prejudices) their followers from being gentlemen; whereas, though every farmer is not a gentleman, yet any gentleman may become a farmer, without in any degree lowering his rank and character; a farmer may, therefore, if he chooses to adopt the habits and manners of a gentleman, be reckoned as such. Thirdly, the farmer's products are in universal demand, and he is sure of a market at some reasonable rate, a fact otherwise with many manufactures. Fourthly, he is sure of a home, of the necessities of life, and in general, of most vigorous health. Fifthly, he is generally a man of more parochial influence than the tradesman or manufacturer.

7174. *No farmer ever makes a fortune by his profession*: the utmost exertions of the most skilful and industrious men in the most improved districts, seldom do more than enable them to keep pace with the times; and the great majority, in all countries, lead a life of great labor and anxiety, and end as they began. No farmer, in a general way, can raise more than one corn crop in a year, and in this respect, the farmer of Russia and Poland has the advantage of the British farmer; for the lands of the former being from five to eight months under snow, all root-weeds are destroyed, and the ground so loosened by the frosts and thaws, as to require very little stirring for the seed; the rapid summer which succeeds ripens all annual plants that will grow there, nearly as well as in England, and better than in many parts of Scotland and Ireland. The British farmers, however, have the great advantage of perpetual pastures, owing to the mildness of our winters, but still no art of man will shorten the period of animal gestation, and originate a lamb or a calf in shorter periods than 5 months and 40 weeks. How often does the tradesman or manufacturer turn his capital in that time? There are three varieties of professional farmers, however, which occasionally realize some property; the grazier who feeds with oil cake, grains, and other artificial foods; the dealer in corn or cattle, who has the art to buy at a falling and sell at a rising market; and the dealer or jobber in farms, who sublets or sells his lease, or in purchases of land, who subdivides and sells estates. The profits of the first are not great, and those of the two last are attended with great risk: the only farmer whose lot is to be envied, lives under a landlord who does not take the full marketable price for his lands: such as Burdet, Coke, Bedford, Northumberland, and many others in the south, but few in the north or the west.



# KALENDARIAL INDEX.

THOUGH agricultural operations, in general, require less nicety as to the exact time of performing them than many of those of gardening, yet there are exceptions in respect to some field crops; for example, beans and turnips. It is proper to observe, therefore, that the *almanac time* in this kalendar is calculated for the meridian of London; but as a *kalendar of nature* is given for the metropolitan district, the almanac time may, in every part of the empire, be varied to suit the local climate and vegetation.

In general, other circumstances being alike, four days may be allowed for every degree, or every 70 miles north or south of London; in spring, operations may be commenced earlier in that proportion southwards, and later northwards; but in autumn the reverse, and operations deferred as we advance southwards, and accelerated as we proceed to the north. In every case allowing a due weight to local circumstances.

Our notices under each month extend only to a few of the leading features of country-work; — to attempt to insert every thing, or even most of the things that require attending to, we conceive impossible; and, if it could be done, quite useless. A man will always act better when guided by his own judgment, than when following implicitly that of another. Kalandars should only be considered as remembrancers, never as directories.

## JANUARY.

Weather at	Average of the Thermometer.	Greatest Variation from the Average.	Average of the Barometer.	Quantity of Rain.	REMARKS.
London -	35 9	6	29 56	1.957 inch.	A cold January is reckoned seasonable; the air being drier during a low state of the thermometer than when it is a little above or below the freezing point; winter-cold is generally less felt by animals than that of March. Winds often prevail during this month. The kalendar of animated nature is much more to be depended on than the vegetable kalendar; for, excepting the catkins on trees, the state of the other plants during this month depends much on the character of the preceding autumn.
Edinburgh	34 5		29 194	2.994	
Dublin -	39 92		29 721	2.697	

### 1. Kalendar of Animated Nature round London.

In the first week: shellless snails (*Helix*), and earth-worms (*Lumbricus terrestris*) appear.

Second week: redbreast (*motacilla rubicola*) whistles, nut-hatch (*sitta europæa*) chatters, missel thrush (*urdus vivivorus*) sings, and wagtails (*motacilla alba et flava*) appear.

Third week: the common lark (*alauda arvensis*) congregates.

Fourth week: snails (*helix hortensis*) and slugs (*limax ater et hyalinus*) abound in sheltered parts of gardens; the hedge sparrow (*motacilla modularis*) whistles, the large titmouse (*parus major*) sings, and flies appear on windows.

### 2. Kalendar of Vegetable Nature round London.

In the first week: some plants accidentally in flower; and others, as the laurusinus, continued from December.

Second week: winter acornite (*eranthis hyemalis*), Christmas-rose (*hedelorus fetidus*) in flower, and hazel (*corylus avellana*) catkins beginning to appear: common honeysuckle (*lonicera periclymenum*) buds begin to appear.

Third week: primrose (*primula vulgaris*) flowers in sheltered places; daisy (*bellis perennis*), and chickweed (*alsine media*) begin to flower.

Fourth week: mezerion (*daphne mezereon*) begins to flower; and sometimes spurry (*spergula arvensis*), pansy (*viola tricolor*), white scented violet (*viola odorata*), arch-angel (*tanium rubrum*), and coltsfoot (*tussilago purpurea et odorata*) show blossoms.

### 3. Farm-yard. (2740.)

Attend to cattle, whether in the open yard on straw and a few turnips, (4898.) in hammels for feeding, (6177.) or in stalls, (6174.) See that the weak are not driven from their proper share of green food by the strong; notice any in bad condition, and put them in a place by themselves for a few weeks. When the hay or straw is of inferior quality or flavor, sprinkle with salt water, which will make it more palatable.

Threshing (2961.) goes on pretty regularly at this season for the sake of a supply of straw. In some districts it is common to thresh an hour every morning with candle-light during the three winter months, the candles being hung up in lanterns. See that the gudgeons and other places are kept oiled, and the teeth of wheels greased or soaped, or coated with anti-attrition.

Implements not now in use may be repaired, also harness greased, ropes spliced, and various evening jobs executed, where it is customary to work a part of the winter evenings.

Men's lodge. (3856.) In some districts the unmarried farm-servants have a common living room in the farmery, with a sleeping-room over, or sleeping-rooms over the horses. It is the duty of the farmer or bailiff to see that these young men are properly occupied during the long winter evenings. A portion of every man's time will be taken up in mending his clothes or shoes, and sometimes in oiling and cleansing horse harness; the rest they ought to be encouraged to pass in reading, or otherwise instructing themselves. One may read aloud to the rest; one may instruct the others on any subject; a

master may be got in for an hour or two every evening, who would teach them all. A master suitable for this purpose will often be found among the married servants, or among the village mechanics. To serious studies may be joined recreative ones, such as the flute, violin, story-telling, singing, speech-making, dramatic attempts, &c. The bailiff or farmer should occasionally come and examine each lad, and bestow some mark of approbation on the most deserving.

### 4. Live Stock. (5546.)

Store fawns (6451.) whether of sheep or cattle, require considerable attention during the winter and spring months to supply straw and hay, with such green food as can be spared, to stock on scanty pastures; and to shelter during storms, especially of snow.

Lambs dropped during this month by the Dorset sheep, and near London are generally kept in the house and fed. (6483.) These require regular attention.

Calves, fattening at this season (6167.) should be kept very clean, and their supplies of milk liberal. Calves to be reared as stock should never be dropped sooner than April.

Figs (6558.), poultry (6680.), and stock in general, should be kept in good heart at this season, otherwise in the spring months they will be fit for nothing, and half the summer will elapse before they recover the bad effects of winter starvation.

Fish, when the ponds are covered with ice, require attention, to break holes to admit air. (6800.)

Bees if dormant do not require to be fed; but if the weather is so mild, or they are placed in so warm a situation as to occasion their flying about, they should be examined, to ascertain if feeding be requisite. (6827.)

### 5. Grass Lands. (5086.)

Dry soils and uplands should alone be stocked with cattle or young horses at this season. (5257.) Sheep should not be allowed to graze either on wet marshy meadows or on young clovers. (5005.) Grass lands, under a system of irrigation, may now be kept covered. (4058.) Clayey soils and others not properly drained should now have that operation effectually performed on the surface (3973.) or under it (3961.), according to circumstances.

Worms (6921.) on some soils do considerable injury to grass. Where the labor is not considered too much, and there is a water barrel at any rate, they may be killed by mixing powder of lime with the water, at the rate of one pint to ten gallons. On lawns, and in small paddocks, or in the care of *Ferme ornée* getting rid of worm casts is an object worth attending to, and this month, February, and October, are the best seasons for the operation.

### 6. Arable Lands. (4548.)

Plough when the soil is not too wet. Lead out dung and farm field dung-hills, also compost heaps, with peat or other matters. See that drains, ditches, and water-furrows run freely, and answer their respective ends.

**Beans (4764.)** are in some dry situations planted in the last week of the month; and also pease, and sometimes oats, are sown. On the whole, however, it is better to defer the beans and pease till the first and second weeks of February, and the oats till the two last weeks of that month.  
**Spring wheat** of the common kind (4622.) may be sown where the soil is suitable.

**7. Fences (2767.), Roads (3280.), and Drains. (3909.)**

**Hanethorns** may be planted in fence-lines, in any of the different modes. (2750.) Ditches, walls, palings, and all other fences of the common kind may be formed; but none where hollies or other evergreens are to be used. Repair by the different modes. (2794.) Roads and drains may be formed at all times and seasons.

**8. Orchards (3770.) and Hop-grounds. (5393.)**

**Prune trees** and free them of moss. Where digging round each tree is practised, this is a good season. Stake and tie newly planted trees. Plant orchards. Trench ground for hop plantations. (5400.)

**9. Wood Lands and Plantations. (3627.)**

**Prepare the soil** for planting. Plant deciduous hard wooded trees in mild weather. Plant and sow the larger tree seeds, whether in places where they are finally to remain, or in nursery-grounds.

**Fell timber and coppice** not valuable on account of its bark. Stock up roots, stack them, and char them.

**Prune** deciduous trees; fill up vacancies. Cut hawthorn hedges. (2790.) Gather any tree seeds not before gathered.

**Drain** wood-lands and cut paths or other openings required through them, the leaves being now off the deciduous sorts.

FEBRUARY.

Weather at	Average of the Thermometer.	Greatest Variation from the Average.	Average of the Barometer.	Quantity of Rain.	REMARKS.
					This month (the <i>spring or sprout kale month</i> of the Saxons) is usually subject to much rain, or snow; either is accounted seasonable: the old proverb being, "February fill dike with either black or white." Round London, the sap in vegetables shows evident symptoms of motion about the middle of the month, and sometimes a week earlier. The animal calendar, and inflorescence of native trees for this month will generally be found very correct.
London -	42 5	5	29 94	0-875 inch.	
Edinburgh	36 6		29 556	1-269	
Dublin -	45 78		30 091	2-21	

**1. Kalendar of Animated Nature round London.**

**In the first week:** bees (*apis mellifera*) come out of their hives, gnats (*culex*) play about, insects (*insecte*) swarm under sunny hedges, and the earth-worm (*lanbrius terrestris*) lies out; hen-chaffinches (*fringilla*) flock, and the song-thrush, or throble (*turdus musicus*), and common lark (*alauda arvensis*) sing.

**Second week:** the bunting (*emberiza alba*), and linnets (*fringilla linota*), appear in flocks; sheep (*ovis aries*) drop their lambs; geese (*anas anser*) begin to lay.

**Third week:** rooks (*corvus frugilegus*) begin to pair, and resort to their nest-trees; house-sparrows (*fringilla domestica*) chirp, and begin to build; the chaffinch (*fringilla caelebs*) sings.

**Fourth week:** the partridge (*tetrao perdix*) begins to pair, the blackbird (*turdus merula*) whistles, and the wood-lark (*alauda arvensis et arborae*) sings; the hen (*phasianus gallus*) sits.

**2. Kalendar of Vegetable Nature round London.**

**In the first week:** the snowdrop (*galanthus nivalis*), whin (*ulex europaeus*), white deadnettle (*lamium album*), polyanthus (*primula veris*) flowers; and the elder (*sambucus nigra*), and some roses and honeysuckles begin to expand their leaves.

**Second week:** common crowfoot (*rannunculus repens*), dandelion (*leontodon taraxacum*), and the female flowers of hazel (*corylus avellana*) appear.

**Third week:** veronica agrestis in flower; many of the poplar and willow tribe show their catkins; and also the yew (*taxus baccata*), alder (*alnus communis*), the tulip (*tulipa*), crown imperial (*fritillaria imperialis*), and various other bulbs, boldly emerging from the ground.

**Fourth week:** the erica carnea, wood strawberry (*fragaria vesca*), some speedwells (*veronica*), the groundsel, and sometimes the stocks and wall-flower (*cheiranthus*) in flower. Some sorts of gooseberries, apricots, and peaches, beginning to open their buds.

**3. Farm Yard. (2740.)**

See last month. In taking in stacks to thresh, destroy vermin as much as possible (6855.). Clear away the bottoming of straw, faggots, or other temporary matter, and leave the site perfectly neat and clean: the poultry will pick up what grains may have dropped. Be vigilant in keeping stock of every description in order; wintering cattle by frequent supplies of fresh straw and turnips, or other roots; horses by sound corn, and good pease-straw, or clover-hay, dispensing as much as possible with wheat and oat straw. The evening food should, occasionally at least, be of carrots or potatoes.

Poultry now lay freely, and if some indicate a desire to incubate, so much the better, where an early brood is an object. **Men's lodges.** There are still a good many hours for mental improvement.

**4. Live Stock. (5546.)**

Sheep generally begin to lamb during this month, and require unremitting attention from the shepherd. (6381.) At-

tend to feeding lambs as before (6483.), and to milch cows (6183.) and fattening calves (6167.)

**5. Grass Lands. (5086.)**

See last month. Manures, where applied to grass lands, may be laid on at this season; and such old mow lands as are to be broken up, may now be pared with a view to burning next month.

The watering of meadows in warm situations may be partially left off towards the middle of the month, to encourage the growth of the grass. (4056.)

**6. Arable Lands. (4548.)**

Beans should be put in during this month. (4764.) Pease for peckling, and for a ripened crop, may be sown at different periods (4759.), and tares for soiling or seed. (4795.) Oats sown from the middle of this month to the middle of March (4694.), unless on very old turf, where they may be sown later. It is a common, but erroneous opinion, that old grass lands intended to be broken up and sown with oats or beans, should be ploughed as early as possible, so as the frost may have some effect on the furrow before seed time. But this, though most plausible, is most dangerous doctrine, it being found from experience, that lands so ploughed and sown, are always more subject to have the plant of corn destroyed by the grub, wire worm, or other larvæ. The only safe mode with such lands, is not to plough them till about the middle of March, and then to plough/sow, and roll immediately afterwards. It would appear that by this practice the larvæ of insects are buried so deep, that they have not time to reach the surface before the grain has germinated and grown out of the reach of their attacks, or probably they may be so deeply buried as to be obliged to remain another season under ground; it being known to naturalists, that the eggs, larvæ, and chrysalidæ of many insects, like the seeds of many plants, will, when buried too deep, or otherwise placed in circumstances not favorable for their immediate hatching or germination, remain there, retaining their principle of life till they can make their way, or are by accident placed in circumstances favorable for their development. The safest plan, however, to break up old grass land, is to pare and burn. (5278.)

Spring wheat of the common kind may now be advantageously sown (4605.), and barley is also sown in some warm spots in the last week of the month.

**7. Fences (3909.), Roads (3280.), Drains, Ditches (2767.), Ponds (4130.)**

Hedges may be planted (2785.), grown ones pruned (2788.), old ones plashed or cut down (2794.), and imperfect ones repaired. Walls built (2831.), water fences, and ponds formed (4130.).

**8. Orchards (3770.) and Hop-grounds (5393.)**

See last month.

**9. Wood Lands and Plantations. (3627.)**

As in last month. Where there is a nursery store, nut and kernel tree seeds may now be sown.

MARCH.

Weather at	Average of the Thermometer.	Greatest Variation from the Average.	Average of the Barometer.	Quantity of Rain.	REMARKS.
					The beginning of March usually concludes the winter; and the end of the month is generally indicative of the succeeding spring; according to the proverb, "March comes in like a lion, and goes out like a lamb." The Saxons called this month the <i>lengthening month</i> , in allusion to the increasing of the days. This is a laborious and trying month, both for men and cattle engaged in field operations.
London -	46 4	4	30 20	0-716 inch.	
Edinburgh	41 7		28 886	1-455	
Dublin -	44 09		29 707	2-304	

**1. Kalendar of Animated Nature round London.**

**In the first week:** the ring-dove (*columba palambus*) coos; the white wagtail (*motacilla alba*) sings, and the yellow wagtail (*motacilla flava*) appears. The earthworm (*lanbrius terrestris*), and the snail (*helix*), and slug (*limax*), engender.

**Second week:** the jackdaw (*corvus monedula*) begins to come

to churches; the tom tit (*parus ceruleus*) makes its spring note; brown wood-wails (*strix ulula*) hoot; and the small tortoise-shell butterfly (*papilio urticae*, L.) appears.

**Third week:** the titmouse (*parus palustris*) begins his notes. Various flies (*musce*) appear. The fox (*canis vulpis*) smells rank. The turkey-cock (*meleagris gallo-pavo*) struts and gobbles.

**Fourth week:** the yellow hammer (*emberiza citrinella*) and green wood-pecker (*picus viridis*) sing; rooks, ravens (*corvus*), and house-pigeons (*columba*) build; the goldfinch (*fringilla carduelis*) sings. Field-cricket (*scaberanus*) open their holes; and the common tea (*pyraea irrisata*) appears.

**2. Kalendar of Vegetable Nature round London.**

**In the first week:** various species of the pine, larch, and fir thrive in full flower; the rosemary (*rosemarinus officinalis*), the willow (*salix*) and bay (*laurus nobilis*) in blossom; various trees and shrubs beginning to open their buds.

**Second week:** the common honeysuckle (*lonicera periclymenum*), and some roses in leaf; crocus vertus, and other sub-species, and some scilla in flower. Pilewort (*ficaria*), and creeping crowfoot (*rannunculus repens*), hepatica, and elder (*sambucus nigra*), sometimes in leaf.

**Third week:** saxifraga oppositifolia, draba verna, daphne ponicica, and collina; and lonicera nigra, in flower.

**Fourth week:** the peach, nectarine, apricot, corchyrus japonicus, pyrus, japonica, crown imperial, saxifraga crassifolia, lusus sempervirens, and other plants, in warm situations, in flower, or just advancing to that state.

**3. Farm Yard. (2740.)**

Wintering cattle should be liberally supplied with food from this time, till they can be wholly turned to grass: as straw and hay gets drier at this season, more should be given, and the supply of turnips, or other roots, rather increased than diminished. Where oil cake, brewers' grains, and similar articles can be obtained, they are valuable auxiliaries. Fattening cattle (6185.) and milch cows (6174.) require continued attention to food, cleanliness, and moderate exercise. Working horses must be kept in good condition; if they fall off now, they will not recover themselves for several months. Potatoes may now be cut into sets, preparatory for next month.

**4. Live Stock. (5546.)**

Sheep now drop their lambs freely; and none pay better than such as are turned fed at this time, and finished off in April, on forward pasture. As turnips begin to run to flower about this time, they are apt to prove more than usually laxative, and therefore the stock supplied with them should have an extra supply of hay.

**5. Grass Lands (5086.)**

Meadows intended for mowing (5197.) should now be shut up, their surface having been freed from stones or other extraneous matters, the furrows or water gutters made completely effective, and, if the weather will permit, the surface bush-harrowed and rolled. Meadows which have been flooded during winter will, in favorable situations, shew a considerable crop of grass by the beginning of this month. Turn off the water a week or ten days, till the surface gets firm; then feed with ewes and lambs, giving a little hay in the evening. Calves may also be turned on these meadows, but nothing heavier. The best mode is to hurdle off the grass in strips, in the manner of eating turnips or clover in the places of their growth. Mole (6921.) and worms (6854.) are best destroyed at this season.

**6. Arable Lands. (4548.)**

There are few hardy seeds, whether of agriculture or gardening, that may not be committed to the soil during this month. Spring wheat of the common kind (4605.) may still be sown; but if possible, not later than the middle of the month, oats

(4650.), rye (4694.), barley (4659.), canary corn (3485.), buck wheat (5490.), beans (4764.), pease, tares, &c.

Clover and rye grass (4985-) may now be sown among young wheats after naked fallows, or among spring corn in lands in good heart and fine tilth.

Field beet (4926.), carrots (4962.), parsneps (4951.), and Swedish turnips should be sown the last fortnight of the month, provided the land is dry enough to be sufficiently cleaned, and pulverized to the depth of at least a foot. It more frequently happens that this cannot be got done till the beginning of April, and hence this class of seeds are seldom got in before the middle of that month. The carrots should be first sown, and the Swedish turnip will bear to be the latest. Lands intended for potatoes, cabbages, turnips, transplants, Swedish turnip, and other parts of the Brassicæ kind should be brought forward by such ploughings, cross ploughings, and workings with the grubber, as their nature and state may require. It is one great advantage of the common white turnip, that it admits of two months more time for preparing the soil than other root or Brassica crops. Summer or wheat fallows require at least one furrow in course of the month.

**7. Fences (2767.), Roads (3280.), and Drains (3909.)**

Thorns and other hedge plants may be put in, but the earlier in the month the business is completed the better. This is an excellent season for making or repairing roads (3473.), drains, ponds, embankments, &c. the ground being still moist, and the days sufficiently long to admit of a man's laboring ten hours, or froit six to six. In January, the ground is often too wet, or frozen, or covered with snow, and the days too short for advantageous day labor. In July and August the ground is too dry and hard for spade work, and day labor high on account of the proximity of hay time and harvest.

**8. Orchards (3770.) and Hop-grounds. (5393.)**

Finish pruning fruit-trees (3798.), and also digging round their stems, if that is practised. (3806.) Where young orchards are grazed, see that the guards or fences to the single trees are in repair.

Form plantations of hops (5393.), and open up and dress the hills of established plants, returning the mould to their roots. (5416.)

**9. Wood Lands and Plantations. (3627.)**

**In the tree nursery,** finish sowing acorns, keys, nuts, mast, berries, stones. Sow also the lighter trees, as poplar seed (where it can be got), willow, birch, alder, elm, &c. Transplant from the seed bed, or from narrow to broader intervals, and attend to other parts of the usual routine culture.

**New plantations** may still be planted, endeavoring if possible to finish putting in deciduous trees with the month; using the puddle in dry weather (3666.), and fixing by water (3667.) Where large trees are introduced, the latter generally require to be staked.

Evergreens of the harder kinds, as the Scotch pine, spruce fir, &c. may be transplanted in the last week of the month, but not safely before. They are often put in during any of the winter months, but the result shews the impropriety of the practice: **Fill up blanks** (3683.) in young plantations and hedges, and fill timber, cut over coppice woods, and thin out young woods as in last month. When plantations are to be raised from seed where they are to remain for timber (3645.), this is the month for most seeds, but April is better for the pine and fir tribe. Sow the others in the second or third week of the month, and if resinous trees are to be mixed, a sprinkling of their seeds can be sown over the others in April.

APRIL.

REMARKS.

The weather of this month is distinguished by the rapidity of its changes. It is generally stormy, interspersed with gleams of sunshine, hail, snow, some frost, and occasionally violent storms of wind. It is a month of the utmost necessity to the cultivator of arable land, who during its course finishes the sowing of spring corns and grasses, and begins that of roots and leaves.

Weather at	Average of the Ther- [mometer.]	Greatest Variation from the Average.	Average of the Barometer.	Quantity of Rain.
London	49 9	5	29 77	1.460 inch.
Edinburgh	46 3		29 875	2.414
Dublin	51 125		29 909	2.561

**1. Kalendar of Animated Nature round London.**

**In the first week:** the viper (*crotalus berus*) and woodlouse (*oniscus asellus*) appear: the missetoe-thrush (*turdus viscivorus*) pairs; frogs (*rana*) croak and spawn, and moths (*phalena*) appear.

**Second week:** the stone curlew (*charadrius edicnemus*) clamors; young frogs (*rana temporaria*) appear. The pheasant (*phasianus*) crows; the trout (*salmo trutta*) rises; and spiders (*aranea*) abound.

**Third week:** the crested wren (*motacilla regulus*) sings; the blackbird (*turdus merula*), raven (*corvus corax*), pigeon (*columba domestica*), hen (*phasianus gallus*), and duck (*anas boscha*) sit; various insects appear; and the fieldfare (*turdus pilaris*) is still here.

**Fourth week:** the swallow (*hirundo rustica*) returns; the nightingale (*motacilla lucinia*) sings; the bittern (*ardea rotellaria*) makes a noise; the house martin (*hirundo urtica*) appears; the black-cap (*motacilla atricapilla*) whistles; and the common snake (*crotalus natrix*) appears.

**2. Kalendar of Vegetable Nature round London.**

**In the first week:** the daffodil (*narcissus pseudo-narcissus*), the garden hyacinth (*hyacinthus orientalis*), the wallflower (*cheiranthus cheiri*), the cowslip (*primula officinalis*), the periwinkle (*vinca*), sloe (*prunus spinosa*), and various other herbs and trees in flower.

**Second week:** the ground-ivy (*glecoma hederacea*), gentianella (*gentiana acutilis*), pulmonaria virginica, the auricula, liberis sempervirens, ornithogalum, and most of the common fruit-trees, and fruit-shrubs in flower.

**Third week:** some robinia, andromeda, kalmia, and other American shrubs; daphne laureola, ulmus campestris, chrysanthemum oppositifolium, mercurialis pennis and other plants in flower.

**Fourth week:** the beech (*figus*) and elm (*alnus*) in flower; ivy-berries drop from the racemes; the larch in leaf, and the tulip and some white narcissi and fritillaries in flower.

**3. Farm-yard. (2740.)**

This month will in most situations terminate the wintering of cattle in the straw-yard. Straw is now very dry, therefore turnips, or other green food or roots, should be added in proportion.

Horses should be kept in high order on account of the hard work and extra exertion often required of them during this month. If there are carrots or potatoes to steam for them one day, that will greatly aid hay and corn; if not, steam a part of the hay.

The accidental supplies of food for store pigs and poultry are less abundant during this month, because less time can be spared for threshing. There are fewer wintering cattle, and the yards are generally now cleaned out for the field dung-hills.

**4. Live Stock. (5546.)**

The end of this month is a good time for mares to foal (5600.) and they should have the horse accordingly. (5965.) Attend at the proper periods first to moderate working, and then to entire ease before foaling time. (5972.)

Cows must still be well fed with roots or steamed food, within doors, letting them taste the grass occasionally towards the end of the month. (6185.)

Sheep and lambs generally require a good deal of artificial food during the first half of this month. When the turnips are expended, clover hay, grains of barley which have been malted, rape cake or linseed cake, are the next resources. (5472.)

About the end of the month they may be turned on the pastures, and then it is that mutton generally drops in price:—a hint to the farmer to sell all he can in the early part of April

Where there are water-meadows, the sheep and lambs will have been fattening on these during the whole of the month, — an immense advantage to a farmer.

Poultry of most kinds have now hatched their broods, and require looking after, to see they do not injure one another, nor are attacked by stronger enemies.

### 5. Grass Lands. (5086.)

See that the fences are kept up, and the gates regularly shut and fastened; as cattle newly let out are very apt to wander, and more ready to break through fences than when the herbage is more abundant.

Water-meadows (4655.) are generally shut up for hay about the end of the month, the ewes and lambs being then turned on young artificial grasses, or common provincial pastures, in a sufficiently forward state.

Mowing-meadows of the common kind (5197.), and clovers, and mixed grasses for hay, should be hand-picked, bush-harrowed, and rolled, early in the month, and then shut up for the scythe.

### 6. Arable Lands. (4548.)

Finish sowing all the spring corns (4659.), pease, tares, lucern (5025.), saintfoin, and all other herbage, plants, and grasses. (5086.)

Summer wheat (4602.) may be sown during the whole of the month, also barley in late situations (4659.), pease for late podding, and under peculiar circumstances, tares for cutting green in October and November.

Manufactorial plants, as wood, madder, flax, hemp, mustard, &c.; oil plants, as rape, poppy, and such plants as are grown for medicinal purposes or peculiar uses in domestic economy, as rhubarb, liquorice, buck or beech-wheat, cress, &c. may all be sown or planted from the middle of last to the middle of this month. The first week in April will, in the greater number of seasons, soils, and situations, suit the most of them.

Carrot (4962.), field beet (4926.), parsnep (4951.), and Swedish turnip (4880.), if not sown the last week of March, should be finished during the first ten days of April. A bed of Swedish

turnips should be sown in the garden for transplanting in the field by the end of the month, or the first week in May.

The last fortnight of the month is the best season for planting potatoes (4825.); in the earliest situations this is soon enough for a full crop; in the latest the middle of May will answer better. For very early crops for the supply of summer markets, dry rich sheltered fields may be planted in March. In the moors of Scotland they often plant in June, and still have a crop; at the potatoe is alike obnoxious to late spring and early autumnal frosts.

### 7. Fences (2767.), Roads (3280.), and Drains. (3909.)

All these should have been put in order before, so as to leave the hedger of the farm (6929.), and the laborer of all-work (6926.), time to assist in getting in planted crops, as potatoes, cabbages, &c. in the fields, cropping the garden, mowing, or otherwise dressing the orchard, shrubbery, lawn, or such ornamental or enjoyment ground, as the farmer indulges in round his house.

### 8. Orchards (3770) and Hop-grounds. (5393.)

In some cases fruit-trees may be so overrun with insects towards the end of the month as to make it worth while to burn wet straw under them; but this rarely happens before the middle of May, and even then farm orchards may almost always be left to the birds and vigor of the trees. Hops are generally poled in this month, and the ground between the hills afterwards stirred with the cultivator or ridget as it is called in Kent. (5417.)

### 9. Wood Lands and Plantations. (3627.)

All planting and pruning of deciduous trees should be finished the first week of the month. Afterwards the planting and pruning of evergreens may commence; first the common pine and fir, and afterwards the holly, yew, and other forest evergreens. (3655.) If these can be watered, and staked, so much the better. Barking oaks may in some warm situations be felled the last week of the month, but May is the more general time. (3745.)

## MAY.

Weather at	Average of the Thermometer.	Greatest Variation from the Average.	Average of the Barometer.	Quantity of Rain.	REMARKS.
London -	56 61	2 5	30 02	0.794 inch.	Vegetation now goes on with great vigor, though there are often very cold and even frosty nights, which materially injure the blossoms of fruit-trees, and sometimes the young shoots of the hop and potatoe. Man, in common with other animals, being now full of life and vigor, the consummation of animal desire is frequent; but marriage is better deferred till September, when the offspring will be born in the May or June following, a season of the year when the poor man can better support the expenses of an acquaintance than in the cold month respondent to marriages in May.
Edinburgh	50 4		29 585	1.945	
Dublin -	52 193		30 061	1.812	

### 1. Kalendar of Animated Nature round London.

In the first week: the titlark (*Alauda pratensis*) sings, the cuckoo (*Cuculus canorus*) is heard; the gudgeon (*Cyprinus gubio*) spawns; the redstart (*Motacilla phænicurus*), swift (*Hirundo apus*), white-throat (*Motacilla sylvia*), and stinging-ly (*Cynops calcitrans*) appear.

Second week: the turtle-dove (*Columba turtur*) coos; the red ant (*Formica rubra*), the laughing wren (*Motacilla carucica*), the common flesh-fly (*Musca vomitoria*), the lady-cow (*Coccinella bipunctata*), grasshopper lark (*Alauda locustæ voce*), and willow-wren (*Motacilla sylvatica*), appear.

Third week: the blue flesh-fly (*Musca vomitoria*) appears; black snails (*Helix nigra*) abound; the large bat appears.

Fourth week: the great white-cabbage butterfly (*Papilio brassicae*), and dragon-fly (*Libella 4-maculata*) appear, the glow-worm shines, and the fern-owl, or goat-sucker (*Cyprinus europæus*) returns.

### 2. Kalendar of Vegetable Nature round London.

In the first week: geum urbanum, artemisia campestris; lily of the valley (*Convallaria majolica*), water-violet (*Hottonia palustris*), tulip-tree (*Liriodendron tulipifera*), and numerous other plants in flower.

Second week: the oak, ash, sweet chestnut (*Fagus cactanea*), hawthorn (*Mespilus germanica*), the common maple (*Acer campestre*), horse-chestnut (*Aesculus hippocastanum*), barberry (*Berberis vulgaris*), and the ajuga reptans in flower.

Third week: the water scorpion-grass, or forget-me-not (*Myosotis scorpioides*), lime-tree (*Tilia*), milk-wort (*Polypogon vulgaris*), nightshade (*Atropa belladonna*), and various American shrubs in flower, and rye (*Secale hybridum*) in ear.

Fourth week: oaks, ashes, and beeches now generally in leaf, and the mulberry (*Morus nigra*) beginning to open its buds. The cinnamon rose, and some other hardy roses in flower; and also the tangle (*Rubus fruticosus*), moneywort (*Lythamchia nummularia*), columbine (*Aquilegia vulgaris*), and various other trees and shrubs in blossom.

### 3. Farm-yard. (2740.)

Feeding and wintering on straw and roots generally ends, and soiling (5004.) or pasturage (5017.) commences, in the first fortnight. Where high-flavored milk and butter are preferred to quantity, then pasturage on dry-bottomed uplands is to be preferred; but where quantity and richness is the object, soiling with clover and tares, and two or three hours' pasturage per day, for the sake of exercise, is the preferable system. Even on farms where there is nothing to mow but old meadow, soiling with that will be found more economical than pasturing it. A field of meadow in good heart, mown and eaten green, will, at a rough estimate, produce treble the quantity of milk it would have done if pastured, and four times as much as it would do in the form of dry hay.

The yards and pits are generally cleared of dung, urine, &c. at this season; and if no soiling goes on, they should be kept

clean during the summer, excepting what room is required for the dung of the few stock which are there constantly, as pigs and poultry, or occasionally, as horses while harnessing, &c.

### 4. Live Stock. (5546.)

In turning cattle to grass, consider the different systems of pasturing (5240.); adopt what suits your circumstances, and pursue it regularly. See that water is not wanting to each field (4127.); nor shade, rubbing posts, and shelter. (6256.)

Lea stock are generally dard during this month, from the number of persons who buy in and feed off on grass. When cattle or sheep are very numerous, they are found to feed better, and do less injury to the grass, in small herds or flocks than in large ones.

Mares may have the horse during the first week, but not later, considering the season of parturition. (5968.)

### 5. Grass Lands. (6086.)

As most grasses send up their flower-stalks during this month, it is of importance so to stock pastures, as to eat these down. This is only to be accomplished in recently sown downlands by overstocking, and not then completely if dry-grass prevails. When grass-lands are to be mown, the best crop of hay will be obtained by not pasturing after the middle of April. Some may think that where cattle and sheep are fed till May or June, the stalks left will come in as hay; but as such fields cannot be mown till the end of July, the stalks have long before shed their seed and become dry, and so shrivelled as to be unfit for food.

Where paring and burning is wanted, this is a favorable season. (2971.)

Water-meadows having been eaten down in April, are generally watered for the first three or four weeks of this month, to bring forward the crop of hay. (4096.)

### 6. Arable Lands. (4548.)

Summer wheat (4602.) and grass seeds (4602.) may still be sown, but not profitably after the first week or ten days. Swedish turnip (4883.), marygold, and yellow turnip, may be profitably sown, and also early crops of common white turnip where the soil is clean and duly prepared. (4887.)

The preparation of turnip fallows is the great business of this month, and next the stirring of naked fallows (4568.), and the culture, by horse and hand hoes, of corns and pulse in drills. In late situations potatoes may be planted during the whole month (4845); and hemp and flax sown during the first fortnight. (5292. and 5327.) Tares for successional supply. (4795.)

### 7. Fences (2767.), Roads (3280.), and Drains. (3909.)

Clean young hedge-rows. (2789.) Drains may now be advantageously designed, as the springs show themselves more con-

spicuously during winter. The rest in this department is mere routine.

8. **Orchards (3770.) and Hop-grounds. (5393.)**

Grafted trees should be looked over occasionally, and any that the clay has dropped from recovered. Remove suckers and superfluous side shoots.

Stir and clean the hop-plantations; place the poles, tie the vines where necessary, and towards the end of the month, when the number of shoots wanted have taken the lead, cover

the stool or centre of the plant with a small hill of soil, to prevent it from sending up more shoots.

9. **Wood Lands and Plantations. (3627.)**

Continue to bark oak trees, and also the larch, and such others as are adapted for the farmer (3740), but finish, if possible, by the middle of the month. Keep newly-planted large trees properly staked, and all kinds of cultivated ground clear of weeds.

JUNE.

Weather at	Average of the Thermometer.	Greatest Variation from the Average.	Average of the Barometer.	Quantity of Rain.	REMARKS.
London -	63 22	2	29 93	0.332 inch.	The weather is sometimes cold at the beginning, but is generally agreeable and steady towards the middle of the month. By observing the columns indicating the greatest variation of the thermometer in each month, it will be seen that it varies, in London, only two degrees in June, which is less than in any of the preceding months. In July and August the variation is the same; but in March and October it is twice as much.
Edinburgh	57 2		29 666	1.935	
Dublin	58 76		50 06	0.860	

1. **Kalendar of Animated Nature round London.**

In the first week: the sedge-sparrow (*passer arundinacea*), the fly-catcher (*musciapa atricapilla*), the wasp (*vespa vulgaris*), and several species of the bee and butterfly appear.

Second week: the burnet moth (*sphinx filipendula*), and forest-fly (*hippobosc equina*) appear; bees swarm.

Third week: several flies, butterflies, moths, beetles, and other insects appear.

Fourth week: insects abound; and singing-birds begin to retire to the woods, and leave off singing.

2. **Kalendar of Vegetable Nature round London.**

In the first week: water-lilies (*nymphaea*, & *nuphar*) flower; also iris pseud-acorus, anthemis cotula, polygonum persicaria, malva rotundifolia, and numerous other plants.

Second week: the vine, raspberry, and elder in full flower; also various Scotch roses (*rosa spinosissima*), broom (*spartium*), nettle (*urtica*), and wheat in the ear.

Third week: the orchis, epilobium, iris xiphium and xiphoides, the hardy iris and gladioli, and a great variety of garden and field plants in flower; also the wheat and many of the pasture grasses.

Fourth week: some black and red currants ripe, strawberries in abundance; young shoots of trees and shrubs have nearly attained their length. Oats and barley in flower; blue-bottle, scabious, (*centaurea cygnus*), and numerous others in bloom.

3. **Farm-yard. (2740.)**

Stalling is the principal operation now going forward (5004), and requires the utmost attention to the cleanliness of the animals, whether fattening cattle, feeding milch cows, or horses.

4. **Live Stock. (5546.)**

Wash and shear sheep (6411.); examine flocks individually as to the fly (6436.); see to shade for every description of stock when the weather is hot. Bees swarm during this and next month.

5. **Grass Lands. (5086.)**

Hay-making is now a principal business (5006. and 5217.) Any tussocks or flower-stalks (bents) which appear, not-

withstanding the close feeding of April and May, should now be mown (5201.); thistles and similar weeds cut out close by the root (5542.); pare and burn as in May (2971.) clean out ponds, water-courses, wells, &c. See that clovers, tares, or other selling crops are mown close to the soil.

6. **Arable Land. (4548.)**

Great part of the turnip process goes on during the three first weeks of this month and the latter half of May. (4876.) Dung fallows and otherwise bring them forward (4568.); draining (5909.), levelling, altering ridges, &c., as the case may require; weed broad-cast crops, and stir the soil between such as are in rows. Waring, where it can be practised, may now be commenced (1117.); thin out the first sown turnips. (4893.)

7. **Fences (2767.), Roads (3280.), and Drains. (3909.)**

Weed hedges, but avoid clipping them, which only creates a close surface of feeble shoots, that in the end becomes so thick as to exclude light and air from the central stems, and occasions their languishing and death. (2792.)

Dig and otherwise prepare materials for roads (5386.) and drains. (5363.)

8. **Orchards (3770.) and Hop-grounds. (5393.)**

Insects, or other effects of what are called blights, can seldom be destroyed on so large a scale as that of the farm-orchard or hop-garden. Burning weeds or wet straw, litter, &c. will do something; and on a small scale, washing with lime-water, soap-suds, tobacco-water, or a mixture of these, will prove effectual. (3440.) Those who tie the binds or vine of the hop to the poles, instead of leaving them to nature, have generally completed the operation by the middle of the month. In some early spots the superfluous shoots are cut off about the end of the month.

9. **Wood Lands and Plantations. (3627.)**

The wood-man is now chiefly employed in trussing up the branches of barked trees, and otherwise disposing of what is unfit for timber purposes. (3745.) Old copses or stools of trees, woods, or hedges, may now be advantageously stocked up, stacked, and, when dry, charred for fuel. (3762.)

JULY.

Weather at	Average of the Thermometer.	Greatest Variation from the Average.	Average of the Barometer.	Quantity of Rain.	REMARKS.
London -	66 3	2	29 89	2.194 inch.	This was called hay month by the Saxons; and though hay-making near London is generally finished in June, yet in places where manure is less abundant, it is chiefly made in this month. The farmer's prospects as to crop may now be determined as to almost every article cultivated.
Edinburgh	60 6		29 445	2.546	
Dublin	61 13		29 929	2.614	

1. **Kalendar of Animated Nature round London.**

In the first week: the cuckoo (*cuculus canorus*) leaves off singing; the stone-curlew (*charadrius adienemus*) whistles occasionally late at night, and the golden-crested wren (*motacilla regulus*) now and then chirps.

Second week: the quail (*tetrao ferrugineus*) calls; the cuckoo-pit, or frog-hopper (*icada spumaria*) abounds.

Third week: young frogs migrate. Hens moult.

Fourth week: the great horse-fly (*tabanus bovinus*) appears; and partridges fly.

2. **Kalendar of Vegetable Nature round London.**

In the first week: enchanter's nightshade (*circea lutetiana*) and lavender (*lavendula spica*) in flower, and pinks and carnations in full bloom.

Second week: the fallen star (*tremella naticae*) appears; also puff-balls (*lyoperdon bovista*), and sometimes the common mushroom (*agaricus campestris*).

Third week: raspberries and gooseberries ripe, potatoes in flower, asparagus in berry, the liliums in perfection.

Fourth week: the truffle (*tuber cibarium*) now hunted, or dug up in commons and forests; nightshade (*solanum nigrum*), devil's bit (*scabiosa succisa*), burnet-saxifrage (*pimpinella saxifraga*), and a great number of plants in flower.

3. **Farm-yard. (2740.)**

As in June; between hay and corn harvest is generally a very good time for the farmer to make a tour to observe more extensively the practices of his own district, and to witness those of other districts.

4. **Live Stock (5546.) and Grass Lands. (5086.)**

Lambs are now weaned (6428.) when not fattened off; at first they require the richest keep. As green food will now be abundant, every animal about a farm that can live and thrive, or answer its end by the soiling system, should be so treated. The weather being hot, cattle or sheep in fields must be frequently locked to, as to shade, water, and abundant keep. Suffering from thirst, or a want of food, they are very apt to break through fences, which at this season is more than usually injurious, on account of the state of the corn crops.

6. **Arable Lands. (4548.)**

Attend to weeding, hoeing, and otherwise moving the soil between rowed crops, more especially potatoes and turnips. Towards the end of the month, the first-sown white turnips will be in a state to thin out; and a farther thinning may be advantageously given to field beet, carrots, &c. at this season. Where pease are sown for podding, they will now be in

abundance for gathering; in warm situations sooner. Buck wheat may now be sown for autumnal food for game. (5490.)

**7. Fences (2767.), Roads (3280.), and Drains. (3909.)**

As in June.

**8. Orchards (3770.) and Hop-grounds. (5393.)**

Cherries, strawberries, gooseberries, &c. where grown as field-crops, are now in gathering, and towards the end of the month, fallen apples and plums for tarts. Hop-grounds are looked over, and the superfluous vine pruned off, &c. In Kent

and other places these prunings are often a perquisite of the pruner, who lays them aside as fodder for cows.

**9. Wood Lands and Plantations. (3627.)**

As in June; and prune the gear, which at other seasons is apt to bleed. (5692.) This season answers perfectly for pruning all sorts of trees, and if their leaves and spray were an object for fodder, as in Sweden and Italy, no doubt it would be preferred. (3691. and 3693.) Wounds in trees do not now bleed as they sometimes do in spring and autumn, and they heal, and are in part covered over with bark, before the approach of winter. (3696.)

AUGUST.

Weather at	Average of the Thermometer.	Greatest Variation from the Average.	Average of the Barometer.	Quantity of Rain.
London -	65 85	2	30 06	0.824 inch.
Edinburgh	60 6		29 828	1.996
Dublin -	62 82		30 172	5.558

REMARKS.  
This is the barn, or *harvest month* of the Saxons; and, as every body knows, the busiest month of the agriculturist. It is, in consequence, the most profitable season for the laborer and his family, who are generally in full employ, and at an increase of wages, or perquisite, for four or six weeks at this season.

**1. Kalendar of Animated Nature round London.**

In the first week: flying-ants (*formica*) appear; bees kill their drones; and the swallow-tailed butterfly (*papilio machaon*) appears.

Second week: young martins (*hirundo urticae*) and swallows (*hirundo rustica*) begin to congregate, and swifts (*hirundo apus*) to depart; the whame, or burrel-fly (*astrus bovis*) lays eggs on horses.

Third week: the black-eyed marble butterfly (*papilio semele*) appears. Various birds resume their spring notes.

Fourth week: the nuthatch (*sitta europaea*) chatters, the stone-crow (*caprimulgus edicnemus*) whistles at night, the goat-sucker (*chirmitiglus europaea*) and young owls (*strix ulula*) make a noise in the evening; robin-redbreast (*motacilla rubicola*) sings; and rooks roost on their nest-trees.

**2. Kalendar of Vegetable Nature round London:**

In the first week: mellot (*trifolium officinale*), rue (*ruta graveolens*), yellow sucoory (*picris hieracioides*), burdock (*arctium lappa*) in flower; the bread-corns ripe.

Second week: wild clary (*silva verbenacea*), meadow-rue (*thalictrum flavum*), ploughman's spikenard (*conyza squarrosa*), and various other natives in flower.

Third week: the mallow (*malva*), lavender, hollyhock (*alcea rosea*), and lobelias, among the garden-flowers; and the polygoums and potamogetons among the wild plants now in blossom.

Fourth week: the autumnal crocus (*colchicum autumnale*), aster, solidago, senecio paludosus, teasel (*dipsacus fulonum*), and various other plants in flower. The earlier varieties of all the hardy kernel fruits ripe.

**3. Farm-yard. (2740.)**

The rick-yard should now be attended to (2744.); stack-stands repaired or put in order; bottoming of faggots, and straw or rape haulm got together; thatch in readiness, and ropes made. (2947.)

At any spare period the teams may be employed carting out the summer-made dung to the wheat fallows, or to form field dunghills for spring crops, &c.

**4. Live Stock. (5546.)**

Select the stock of lambs to be kept as breeders. (6434.) Swine commonly bring their second litter of pigs in this month, which, owing to the dropping corn, is generally one of abundant keep, both for them and poultry. Farmers in some places look to the stubbles as a source of good food for their cows, as

others do to the fallows for keep for their sheep. Where either is the case, the culture must be of a very inferior description.

**5. Grass Land. (5086.)**

Where meadows are manured, that operation generally goes on after the hay is removed, or during winter; the surface in the former case being hard with drought, and in the latter by frost. Ategrass should in general be shut up and reserved for later keep, and in some cases as a winter resource. Keep down weeds, tussocks, antheills, &c. Turn the water on meadow-lands as soon as the hay is removed, and let it remain till a third crop is in forwardness. (4058.)

**6. Arable Lands. (3548.)**

Weed and stir among green crops, earth up potatoes (4855.), but by no means turnips, as that operation only prevents them from attaining a full size. (4895.) Reaping commences in all the southern districts in the first week of this month, and in some by the middle of July. When the operation is executed by day-work, the most unremitting inspection of the master is necessary; and even when the greatly preferable mode of reaping by the acre is adopted, he should be continually in motion from one party to another, to see that the operation is performed low and clean.

Naked fallows in late situations receive the seed furrow during this month, excepting in cases where the seed is ploughed in, an operation generally referred to the middle of September. Sow cabbage-seeds (4963) for plants to put out in April next. Sow turnips after early pease which have been podded (4763.), or early cut-wheat, tares, cabbages, &c. or after hemp and flax, which are generally pulled by the middle of this month. (5292. and 5327.) Grass seeds sown alone at this season (4925.) will generally succeed better than at any other; they germinate as well in spring, but the heats of July often burn up the tender plants.

**7. Fences (2767.), Roads (3280.), and Drains. (3909.)**

As in the two preceding months.

**8. Orchards (3770.) and Hop-grounds. (5393.)**

Apples and plums of some sorts are now ripe. Grafts may in general be untied. Budding performed, and pruning, if desirable, as observed last month under woods and plantations.

**9. Wood Lands and Plantations. (3627.)**

See last month.

SEPTEMBER.

Weather at	Average of the Thermometer.	Greatest Variation from the Average.	Average of the Barometer.	Quantity of Rain.
London -	59 63	3 5	30 09	0.482 inch.
Edinburgh	54 3		29 739	3.470
Dublin -	59 35		30 239	3.021

REMARKS.  
The temperature begins now to decline and to vary; the nights begin to lengthen, and heavy dews and diminished transpiration and evaporation promote the growth of grass, herbage, plants, and especially turnips. This is still a busy month with the agriculturist; in the warmest situations he is finishing harvest-work, and in the latest commencing it. Animals of most sorts are now fat; fruits are ripe; honey abundant; and most products of the earth in perfection and plenty.

**1. Kalendar of Animated Nature round London.**

In the first week: young broods of goldfinches (*fringilla carduelis*) appear. The linnet (*fringilla linnaea*) congregates. The bull (*bos taurus*) makes his shrill autumnal noise; and swallows (*hirundo rustica*) sing.

Second week: common owls (*strix flammea*) hoot. The sallow butterfly (*papilio hyle*), and willow red under-wing moth (*phalaena pacta*) appears. Herrings (*clupea harengus*) are now cheap.

Third week: the ring uly (*turdus torquatus*) appears. The fly-catcher (*musciopa atricapilla*) withdraws.

Fourth week: the stare (*sturnus vulgaris*) congregates. The wood-lark (*alauda arborea*) sings. The woodcock (*scotopus rusticola*), and feldfare (*turdus pilaris*) appear; and the swallow (*hirundo rustica*) departs.

**2. Kalendar of Vegetable Nature round London.**

In the first week: the fungus balotus allius appears, travel-ler's joy (*clanetia alba*), and parnassia palustris in flower.

Second week: catkins of the hazel and birch formed; blossoms, and green, red, and black berries found on the Bramble at the same time. Leaves of the sycamore, birch, lime, mountain-ash, and elm begin to change color.

Third week: the ivy (*hedera helix*), laurel (*prunus lauro-cerasus*), and furze (*ulax europaea*) in flower.

Fourth week: hips, haws, and nuts ripe. Leaves of plane-tree (*platanus*) tawny; of the hazel, yellow; of the oak, yellowish-green; of the sycamore, dirty brown; of the maple, pale yellow; of the ash, fine lemon; of the elm, orange; of the hawthorn, tawny yellow; of the cherry, red; of the hornbeam, bright yellow; of the willow, hoary.

**3. Farm-yard. (2740.)**

The rick-yard is now the chief scene of operations, in getting earlier crops thatched (2945.) and later ones stacked. (3055.) In all operations in this department attend, as far as circumstances will permit, to neatness. In the case of a proprietor or amateur, neatness, order, and high keeping are essential in every department.

4. *Live Stock.* (5546.)

There is generally abundance of fat cattle and sheep in the market during this and next month. Lean stock, especially crores and widders, are now brought in, and wintered or fed off on turnips. Wintering cattle (6177.) also about the end of the month. Poultry and pigs are now fat, and honey may be taken from bee-hives.

5. *Grass Lands.* (5086.)

As in August. Newly sown grass lands should now be sparingly fed, in order to strengthen the plants for the winter.

6. *Arable Lands.* (4548.)

This is the chief season for sowing winter wheat, whether on naked fallows or after clover, tares, rape, or early crops of pease and beans. Potatoes are generally not taken up till the end of the month, in which case the sowing after that crop is later. (4613.) Sow tares to stand the winter (4795.), and grass seeds

for permanent pasture, or a hay crop next season will succeed on good soils, if sown before the middle of the month. (4995.)

7. *Fences* (2767.), *Roads* (3280.), and *Drains.* (3909.)

Routine operations of mending, &c. as before.

8. *Orchards* (3770.) and *Hop-grounds.* (5393.)

Gather fruits for immediate sale, the keeping sorts not being yet ripe. (3776.) Walnuts for pickling not later than the first week. (3789.)

*Hop-picking and drying,* in the districts where this plant is much cultivated, is the great business of the month. (5425.)

9. *Wood Lands and Plantations.* (3627.)

Routine operations as in the two or three preceding months. plant evergreens during the three last weeks, and deciduous trees the last ten days. (3655.)

OCTOBER.

Weather at	Average of the Thermometer.	Greatest Variation from the Average.	Average of the Barometer.	Quantity of Rain.	REMARKS.
					The weather of this month is very uncertain. Before those rains, snows, or frosts which constitute the practical commencement of winter, there is generally two or three weeks of settled weather; sometimes these weeks are in October, sometimes partly in November. These weeks afford a last resource for bringing forward neglected operations.
London -	52 81	4	29 69	2.027 in.	
Edinburgh	49 7		29 339	3.354	
Dublin -	51		29 76	2.798	

1. *Kalendar of Animated Nature round London.*

In the first week, the red-wing (*turdus iliacus*) arrives. Snakes and vipers bury themselves.

Second week: hooded crows (*corvus cornix*) and wood-pigeons (*columba palumbus*) arrive; hen-chaffinches (*fringilla caelebs*) congregate, and prepare for migration, leaving their males in this country.

Third week: the snipe (*scolopax gallinago*) appears in the meadows. Wild-geese (*anas sylvesteris*) leave the fens, and go to the eye-lands.

Fourth week: the tortoise (*testudo græca*) begins to bury himself in the ground; and rooks visit their nest-trees. Some larks (*alauda*) sing, and the woodcock (*scolopax rusticola*) returns. Spiders' webs abound.

2. *Kalendar of Vegetable Nature round London.*

In the first week: strawberry-tree (*arbutus unedo*), holly (*Ilex aquifolium*), China hollyhock (*alcea chinensis*), and China aster (*aster chinensis*), in bloom.

Second week: catkins of some species of salix formed; leaves of the asp almost all off; of the Spanish chestnut, yellow; of the sugar-maple (*acer saccharinum*) scarlet; of the common birch, yellow and gold; and of the weeping-birch, gold and bright-red colored.

Third week: clematis calycina in flower. Some horse chestnuts and acacias quite denuded of leaves.

Fourth week: various plants, especially annuals, continue in flower. Leaves of marsh-elder (*sambucus ebulus*), of a fine pink; of stag's-horn samach, of a purplish-red; of the American oaks, of fine shades of yellow, orange, red, and purple.

3. *Farm-yard.* (2740.)

This is the season of rural plenty, affording an opportunity, both to men and animals, for laying in a large stock of health, to enable them to support the severity of the coming winter. Operatives should now buy in their winter stores of potatoes, fuel, &c. and ridge up their garden ground, not under crop, for the winter.

Corn crops being generally in the rick-yard by Michaelmas, and the root and herbage crops not taken being at or near maturity, the first of October is the most suitable season for a farmer to take stock and ascertain his annual profit or loss. Michaelmas being also the most general term of entry and removal, especially in the case of arable farms, is another reason why agricultural accounts are conveniently made up to this period. (4609.) Examine your household accounts, and if your expenses have exceeded your income, or even come up to it, look over the particulars with your wife or housekeeper, and see on which you can retrench. This is an essential process for all who would proceed in life with any thing like peace of mind, or the permanent respect of their neighbors. (4545.) Remember that very small indeed is the net income of a rent-paying agriculturist.

Michaelmas is also the general term for hiring farm servants by the year; but the seldom agricultural operatives are changed the better, unless in the case of senseless, indolent, or viciously inclined persons, who degenerate unless frequently removed.

4. *Live Stock.* (5546.)

Cattle and sheep not sufficiently fatted on grass or herbage whether by pasture or soiling, should now be put on other food, to complete them for the butcher. Oil-cake, grains, turnips, carrots, or, in default of these, bruised corn may be used. The same observations may be applied to hogs, which are generally in good condition at this season. (6570.)

Hog porridge. A mixture of oatmeal and water, or any other meal and water, left till it becomes sour, as practised by the millers in the northern counties, will feed hogs rapidly; but milk and pease meal make the finest pork in the world.

The teams which have been soiled during summer, may now be put on hay, straw, and carrots, or other roots, by degrees. (6083.)

5. *Grass Lands.* (5086.)

Where these are manured, this is a good season for the operation (5208.); choose dry weather.

6. *Arable Land.* (4548.)

Potatoes (4825.), carrots (4926.), field beet (4962.), parsneps (4961.), and Swedish turnips, may now be taken up and housed, and the ground sown with wheat. This grain (5099.), rye (4630.), barley (4659.), in some situations, and tares (4795.) will still be sown in the milder districts. Embrace every opportunity to give the first furrow to fallows (4568.), whether for green crops or otherwise. In general all lands that are to have two or more furrows before they are sown or planted, should be ploughed as soon as possible after harvest; but not so lands that are to be sown on one furrow, which are better ploughed in January and February. It is a great mistake to suppose that ploughing land in autumn destroys the eggs or larvae of insects (6915c), or the seeds of weeds; on the contrary, it may often, by giving them a deeper covering, preserve them better from the winter's frost, or, what is much more destructive, from being devoured by birds. There are few subjects less generally understood than the economy of nature in regard to the eggs of insects and worms. (Turn to 6863. and 6921.) See that water furrows and drains run freely, and that fences and gates are in repair.

7. *Fences* (2767.), *Roads* (3280.), and *Drains.* (3909.)

Hedges may now be advantageously planted (2785.), grown ones pruned (2790c), old ones plashed (2796c), and imperfect ones repaired (2800c). The Northamptonshire practice as to hedges (7024.) deserves the study of the more southern agriculturist. Roads and drains may be made or repaired at this season, and in spring, with better effect than during the heat and drought of summer. Road materials now bind better, and land-springs show themselves more distinctly.

8. *Orchards* (3770.) and *Hop-grounds.* (5393.)

The winter fruits may now be gathered, and either spread in an airy loft or upper floor, there to remain till used, or sweated in heaps, to extract a part of their moisture, and then buried in dry sand, or packed in close boxes or casks, to be kept in a cool and dry cellar. (1797. and *Encyc. of Gardening*, 2289.)

Fruit trees of every kind may now be planted (3793.) and pruned. (5798.)

Hop-picking is generally completed the first week of the month; and as soon afterwards as convenient, the vine and poles removed, and the latter stacked till next spring. (5432.) Young hop plantations may be formed (5398.), and the soil among established grounds manured and ploughed. (5411.)

9. *Wood Lands and Plantations.* (3627.)

Hedges and plantations of evergreen trees may be made during the first week of the month; and no period of the year is better for transplanting all kinds of hardy shrubs.

Timber and coppice may be felled, and in general every operation preparatory to planting, as well as the operation itself, may go forward.

NOVEMBER.

Weather at	Average of the Thermometer.	Greatest Variation from the Average.	Average of the Barometer.	Quantity of Rain.	REMARKS.
					This is the windy month of the Saxons; it is generally also cold and moist, and one of the most disagreeable for the laboring agriculturist; but he may console himself with the shortness of the day, and hail the approach of evening, when he may lay aside his wet dress and fortify his mind by converse with books, or enjoy the comforts of his fire-side, and the solace of his wife and children; reading to or otherwise instructing them, or mending his boots or shoes.
London -	41 44	4	29 68	2.597 in.	
Edinburgh	41 1		29 658	4.514	
Dublin -	43		29 74	0.394	

**1. Kalendar of Animated Nature round London.**

In the first week: the buck (*ceruus capripilus*) grunts.

Second week: the golden plover (*charadrius pluvialis*) appears.

Third week: snails (*limax*) and slugs (*helix*) bury themselves.

Fourth week: greenfinches (*fringilla montifringilla*) flock. The winter moth (*geometra brumaria*, Sam.), and the common flat-body moth (*geometra appiana*, Sam.), appear in gardens about the end of the month.

**2. Kalendar of Vegetable Nature round London.**

In the first week: a few plants in flower, by accident, chiefly annuals, according to the season.

Second week: the fungus *helvella mitra* appears. *Lauritinus* in flower.

Third week: *calycanthus præcox* in flower.

Fourth week: some primroses show flowers at this season; and some plants, unnaturally in flower, still continue if the weather is temperate.

**3. Farm-yard. (2740.)**

Wintering cattle are now introduced to the straw yards (2740.) or trammels (2677.), and others to stalls for feeding or fattening. Live stock in general ought to be kept in good condition at this season, otherwise they are apt to fall off towards spring. Threshing goes on at intervals to supply straw. (2961. and 2625.)

**4. Live Stock. (5546.)**

See farm-yard.

**5. Grass Lands. (5086.)**

Manure in dry weather (5206.); turn the water on meadows adapted for irrigation (4038.); destroy anthills (5202.); drain by surface gutters, or other means, where that operation is requisite; clear out water furrows for the same purpose; admit cattle and horses only on the driest pastures; see that sheep have shelter, and especially Dorset ewes likely to lamb next month.

**6. Arable Land. (4548.)**

See that water furrows and drains run unobstructed; plough and cart out manure, as weather and other circumstances permit.

**7. Fences (2767.), Roads (3280.), and Drains. (3909.)**

As in last month; and see that they are in effectual repair, and fairly used.

**8. Orchards (3770.) and Hop-grounds. (5393.)**

Complete the operations of last month, where interrupted, deferred, or neglected.

**9. Wood Lands and Plantations. (3627.)**

As in last month, excepting when the weather is unfavorable. Felling all kinds of timber and coppice not adapted for barking for the tanner, may now go on freely. (3740.) Willows for baskets may be cut over (3738.), and baskets, hampers, crates, and hurdles, made by the woodman and hedger.

## DECEMBER.

Weather at	Average of the Thermometer.	Greatest Variation from the Average.	Average of the Barometer.	Quantity of Rain.	REMARKS.
London -	41 4	3	29 64	1-124 inch.	Winter month, Sax. Cold but dry. The agricultural operations are chiefly of the laborious kind; but the days are short and the nights long. In the last week the young operator should examine himself as to his professional and intellectual progress during the bye-past year, and form plans for further improving himself for the year to come. Knowledge is a lever by which a man may raise himself as high as he desires.
Edinburgh	38 9		29 66	2-598	
Dublin -	36 34		29 723	2-916	

**1. Kalendar of Animated Nature round London.**

The mole (*talpa europæa*) throws up hillocks. The December moth (*erigaster populæ*, Sam.) appears about the beginning, and the yellow-line quaker (*noctua flavitinea*, Sam.), about the end of the month.

**2. Kalendar of Vegetable Nature round London.**

Some of the last month's plants continue in flower, according to the weather.

**3. Farm Yard (2740.), and Live Stock. (5546.)**

Threshing, and otherwise preparing corn and straw for the market, and the use of the working, fattening, wintering, and store stock are the main operations. Next, the regular supply of live stock with food, and cleaning and littering them. Fattening stock should be particularly attended to, especially house lamb (6486.) and calves (6167.)

The supply of turnips for cattle and sheep is liable to be interrupted by severe frosts, if the precaution of housing a quantity (4904.), or setting them (4905.), is not taken in time. Where oil cake, rape cake, or dust, (5472.) brewers or distillers' grains (4686.) are used, supplies must be secured; and where hogs or cattle are fed on meal and water mixed and soured, a quantity must always be kept in mixture; as a week or ten days in temperate weather, and a longer period during frost, is requisite to induce the fermentation.

**5. Grass Lands. (5086.)**

See that they are not poached: that water furrows, gutters, drains, and ditches are in repair; and where manuring is prac-

tised, cart it out in frosty weather where there is no danger of injury from the feet of horses or cart wheels. Unless labor is very cheap, carting earths or earthy composts on grass lands will not pay the expenses; they produce more effect on arable lands.

**6. Arable Lands. (4548.)**

See that all the modes of drainage are effective. (3957.) Plough and cart out manure according to weather and other circumstances.

**7. Fences (2767.), Roads (3280.), and Drains. (3909.)**

Plant hedges (2784.) and build walls only in temperate weather, as frosty air injures the roots of plants, and freezes humid mortar, thereby effectually preventing its setting. Roads and drains may be made and mended in all weathers that admit these operations.

**8. Orchards (3770.) and Hop-grounds. (5393.)**

Clear old trees of moss or mistletoe; but prune only in mild weather. Dig and dung at any time.

**9. Wood Lands and Plantations. (3627.)**

Fell timber or cove of sorts not adapted for barking. (3740.) Stock or grub up tree roots, stacking them for fuel or charcoal. (3762.) Trench, dig, or otherwise prepare ground for planting; but lift plants from the nursery, and re-insert them in plantations only in mild weather, and when the soil does not poach by treading, &c. The rest as in November.



# GENERAL INDEX.

N.B. *The Numbers refer to the Paragraphs, not the Pages, excepting in the case of the List of Authors, where they refer to the page and the year in which the Author published: in such cases the word page, and letters A. D. are prefixed.*

- ABBATE**, Antonio, his work on agriculture, page 1177, A. D. 1808.
- Abeille**, F., his work on agriculture, page 1173. A. D. 1791.
- Abele poplar**, the largest in England, 6996.
- Aberdeenshire**, agricultural survey of, 7066.
- Aberdeenshire cattle**, 6126.
- Abstergent remedies**, in farriery, are those used for the purpose of resolving or discussing tumors and concretions on the joints and other parts of animals. They mostly consist of volatile, stimulant, and saponaceous matters, 5906.
- Abyssinia**, agriculture of, 1041.
- Acclimating tender animals**, 6634.
- Acclimating vegetables**, 1728.
- Account books of farmers**, 4509; journal, 4512; cash-book, 4514; stock, 4520; books for a common farmer, 4521.
- Acids of plants**, how obtained, and their uses, 1397; oxalic acid, 1398; acetic acid, 1399; citric acid, 1400; malic acid, 1401; gallic acid, 1402; tartaric acid, 1403; benzoic acid, 1404; prussic acid, 1405; composition of vegetable acids, 1406.
- Adam**, James, Esq., his work on agriculture, page 1166. A. D. 1789.
- Adams**, George, his work on agriculture, page 1170. A. D. 1810.
- Adanson**, Madame Aglae, her work on agriculture, page 1175. A. D. 1822.
- Africa**, agriculture of, 1040; Abyssinia, 1041; Egypt, 1045; Mahometan states, 1066; western coast, 1077; Cape of Good Hope, 1087; eastern coast, 1114.
- Age of horses**, criteria of, 5956; deceptions practised, 5958.
- Agricultural authors of England during the sixteenth century**, 231.
- Agricultural circumstances of Italy during the time of the Romans**, 63.
- Agricultural edifices**, 2657; buildings for live-stock, 2661; repositories and working places, 2688; farmer's dwelling house, 2712; cottages for farm servants, 2718; stack-yard, and other yards, 2740; farmeries, 2757.
- Agricultural encampments of Morocco (figured)**, 1075.
- Agricultural establishment of Hofwyl**, near Berne, 343.
- Agricultural establishment of Rossore**, in Tuscany, 297.
- Agricultural establishments by Buonaparte**, 376.
- Agricultural fête of the Chinese**, 1004.
- Agricultural implements**, 2373; tools, 2374; instruments, 2401; utensils, 2433; hand machines, 2447; tillage implements, 2477.
- Agricultural implements**, on the choice of, 4486.
- Agricultural implements of the Romans**, 109; plough, 110; cultivator, 114; harrow, 115; rake, 116; hoe, 117; spade, 120; reaping-hook, 123; threshing implements, 124.
- Agricultural implements of Flanders**, 498.
- Agricultural implements**, their invention in Egypt, 10.
- Agricultural labors of the simplest kind**, 2884.
- Agricultural operations**, 2875.
- Agricultural operations**, mixed manual, 2946.
- Agricultural operations of Flanders**, 508.
- Agricultural operations of order and management**, 3123.
- Agricultural operations of the Romans**, 126.
- Agricultural operations of the scientific kind**, 3053; measuring land, 3054; taking levels, 3059; dividing and laying out lands, 3066; estimating weight, power, and quantity, 3078; estimating value, 3083; professional etiquette as to plans and reports, 3106.
- Agricultural operations with plants**, 2905.
- Agricultural operations with laboring cattle**, 2992; for the care of live stock, 2993; on the soil, 2998; with the crop, 3034.
- Agricultural produce of the Jews**, 36.
- Agricultural servants**, choice of, 4492; bailiff, 4493; ploughman, 4494; shepherd, 4502; laborers, 4503; apprentices, 4505.
- Agricultural servants of the Romans**, 85.
- Agricultural societies**, number of, in England and Wales, by Farey,
- Agricultural survey of England**, 6991.
- Agricultural survey of Scotland**, 7046.
- Agricultural survey of the British isles**, 6989.
- Agricultural writers of antiquity**, 7.
- Agricultural writers of the Romans**, 44.
- Agriculture**, as affected by civil, political, and religious circumstances, 1244; civilization and refinement, 1245; political state of a country, 1246; religion, 1247; natural character of the people, 1248.
- Agriculture**, as influenced by geographical circumstances, 1222; climate, 1222; culture, 1224.
- Agriculture**, as influenced by physical circumstances, 1232; temperature and light, 1233; elevation, 1234; soil, 1237; moisture, 1238.
- Agriculture as practised in Britain**, 3142.
- Agriculture**, British, literary history of, 781; Tull, Bradley, Stillingfleet, Harte, Young, Marshall, &c., 781; Donaldson, 782; Belhaven, 783; Maxwell, 784; Adam Dickson, 785; Lord Kaimes, 786; Wight, 787; Farmer's Magazine, 789; societies, 790; professorships, 791; county reports, 793; Sinclair, 794.
- Agriculture**, British, professional history of, 755; drill husbandry, 756; live stock, 765; implements and machines, 770; Small's plough, 770; improving leases, 773; agricultural societies, 775; draining, 776; threshing machine, 777; farmeries, 780.
- Agriculture**, British, statistics of, 6923; present state of, 6924; different descriptions of men engaged in its practice, 6925; different kinds of farms in Britain, 6981.
- Agriculture**, British, topographical survey of, 6989. England, 6991; Wales, 7046; Scotland, 7043; Ireland, 7074; (See the different counties of each, and under each county the following heads.) 1. Geographical state and circumstances; 2. State of property; 3. Buildings; 4. Mode of occupation; 5. Implements; 6. Enclosing; 7. Arable land; 8. Grass lands; 9. Gardens and orchards; 10. Woods and plantations; 11. Improvements; 12. Live stock; 13. Rural economy; 14. Political economy; 15. Obstacles to improvement; 16. Miscellaneous observations; 17. Means of improvement.

- Agriculture, "British," political history of, 742; laws on wool, 743; on corn, 744; roads, 750.
- Agriculture considered as a science, 1259; object of the art, 1261; mode of instruction preferred, 1262; mode of study recommended, 1263.
- Agriculture, history of, during the middle ages, 179.
- Agriculture, history of, in ultra European countries during the middle ages, 257.
- Agriculture, in regard to the state of society, its divisions, or kinds, 1249; agriculture of science, 1250; of habit, 1251; Barbarian culture, 1251; economy of savages, 1253.
- Agriculture, its classical history, 4.
- Agriculture, its geographical divisions, or kinds, 1227; agriculture of irrigation, 1228; of manures and irrigation, 1229; of draining and manures, 1230; fishing and hunting, 1231.
- Agriculture, its history among ancient and modern nations, 2.
- Agriculture, its history from the deluge to the establishment of the Roman empire, 5.
- Agriculture, its origin and history, 1.
- Agriculture, its physical divisions, or kinds, 1239; agriculture of water-fed lands, 1240; of sun-burnt lands, 1241; of mountains, 1242; of plains, 1243.
- Agriculture, its traditional history, 2.
- Agriculture, literary history of, in England during the seventeenth century, 246.
- Agriculture of Abyssinia, 1041.
- Africa, present state of, 1040.
- Algiers, 1069.
- Amazonia, 1218.
- Ancient Greeks, 17.
- Ancient Moors, 689.
- Arabia, 870.
- Asia, present state of, 846.
- Asiatic Turkey, 847.
- Asiatic islands, 1012.
- Australasia, 1012.
- Austria, 607.
- Bachapins of the south of Africa, 1112.
- Babylon, 36.
- Bavaria, 603.
- Benin, in Africa, 1080.
- Birman empire, 921.
- Boatan, 1007.
- Borneo, 1020.
- Brazil, 1207.
- Britain, 1254; considered geographically, 1255; physically, 1256; socially, 1257.
- Britain after the Norman conquest, 204.
- Britain during the Anglo-Saxon dynasty, 196.
- Britain from the fifth to the seventeenth century, 195.
- British isles, modern history of, 741.
- British possessions of North America, 1166.
- Bushmans of Africa, 1113.
- Cambodia, 943.
- Canada, 1167.
- Canary islands, 1120.
- Cape Breton, 1171.
- Cape of Good Hope, 1087.
- Cape Verd islands, 1119.
- Carolines, 1032.
- Carthage, 38.
- Cayenne, 1215.
- Celebezan islands, 1023.
- Chili, 1214.
- Chinese empire, 951.
- Chinese Tartary, 1005.
- Cochin China, 944.
- Congo, 1082.
- Cuba, 1173.
- Denmark, 588.
- Eastern coast of Africa, 1114.
- Egypt, 8.
- Empire of Morocco, 1072.
- England in the early part of the sixteenth century, 221.
- European Turkey, 729.
- Foulahs of Africa, 1073.
- France from the fifth to the seventeenth century, 185.
- France, present state of, 373.
- Friendly Islands, 1039.
- Germany, present state of, 543.
- Germany from the fifth to the seventeenth century, 192.
- Agriculture of Hanover, 581.
- Hindustan, 877.
- Holland, and the Netherlands, 417.
- Independent Tartary, 865.
- Ireland, 795.
- Island of Ceylon, 914.
- Isle of Bourbon, 1117.
- Italy during the middle ages, 180.
- Italy, present state of, 260.
- Jamaica, 1174.
- Japan, 946.
- Java, 927.
- Jews, 29.
- Ladrones, 1031.
- Laos, 942.
- Loango, 1081.
- Madagascar, 1115.
- Madeira, 1121.
- Mahometan states of the North of Africa, 1066.
- Malacca, 938.
- Manillas, or Phillipine isles, 1022.
- Marquesas, 1033.
- Mauritius, 1116.
- Mexico, 1150.
- Modern Egypt, 1045.
- Moldavia, and Wallachia, 738.
- Moluccas or Spice Islands, 1024.
- New Britain, New Ireland, the Solomon Isles, New Caledonia, and the New Hebrides, 1027.
- New Brunswick, and Nova Scotia, 1170.
- New Holland, 1025.
- New Zealand, 1028.
- North America, present state of, 1127.
- Nubia, 1165.
- Otaheite, 1035.
- Papua, or New Guinea, 1026.
- Paraguay, 1206.
- Patagonia, 1219.
- Pelew isles, 1030.
- Persia, 850.
- Peru, 1203.
- Phœnicia, 37.
- Poland, present state of, 628.
- Polynesia, 1012.
- Portugal, 728.
- Prussia, 563.
- Romans, 42.
- Russia, 645.
- St. Helena, 1118.
- Sandwich isles, 1034.
- Savoy, 347.
- Saxony, 596.
- Scotland from the eleventh to the thirteenth century, 208.
- Siam, 939.
- Sierra-Leone, 1079.
- South America, 1201.
- South American islands, 1220.
- Spain, 688.
- Sumatra, 1013.
- Surinam, 1216.
- Sweden and Norway, their present state, 665.
- Switzerland, present state of, 326.
- Terra-firma, 1202.
- Thessaly and Albania, 736.
- Thibet, 1006.
- Tonquin, 945.
- Tripoli, 1067.
- Tunis, 1063.
- United States, 1130.
- Van Dieman's Land, 1029.
- Wales from the fifth to the seventeenth century, 197, 206.
- Western coast of Africa, 1077.
- West India islands, 1172.
- Agriculture, present state of, in Europe, 259.
- Agriculture, present state of, in ultra European countries, 845.
- Agriculturists, commercial, 6939; jobbing farmers, 6939; itinerant agriculturists, 6940; cottage farmers, 6941; poultry farmers, 6942; garden farmers, 6943; seed farmers, 6944; orchard farmers, 6945; hop farmers, 6946; milk or cow farmers, 6947; dairy farmers, 6948; graziers, 6949; stock farmers, 6950; store farmers, 6951; hay farmers, 6952; corn farmers, 6953; wood farmers, 6954; quarry farmers, 6955; mine farmers, 6956; salmon or river farmers, 6957; commercial or pro-

- fessional farmers, 6958; gentlemen farmers, 6959; yeomen farmers, 6960; farming landlords, 6961. Agricultural counsellors, artists, or professors, 6962; land measurer, 6962; agricultural salesman, 6963; appraiser, 6964; land-surveyor, 6965; timber-surveyor and valuer, 6966; land-valuer, 6967; land-agent, 6968; agricultural engineers, 6969; veterinary surgeon, 6970; agricultural draftsman, 6971; agricultural author, 6972; professor of agricultural science, 6973.
- Agriculturists, patrons, 6974; amateur, 6975; connoisseurs, 6976; employers, 6977; amateur farmers, 6978; noblemen and proprietor farmers, 6979; noblemen and gentlemen improvers, 6980.
- Aigoïn*, —, his work on agriculture, page 1174. A. D. 1805.
- Ainslie*, John, his works on agriculture, page 1169. A. D. 1806.
- Aiton*, William, his works on agriculture, page 1169. A. D. 1805.
- Akee tree (figured), 1186.
- Alamanni*, —, his work on agriculture, page 1177. A. D. 1764.
- Alamanni*, Luigi, his work on agriculture, page 1177. A. D. 1546.
- Albertazzi*, Jacopo Antonio, his work on agriculture, page 1178. A. D. 1811.
- Albin*, Eleazer, his works on birds and fishes, page 1164. A. D. 1737.
- Albrecht*, J. F. E., his work on agriculture, page 1176. A. D. 1775.
- Albumen, how obtained, and its uses, 1380.
- Alcarazas, or water pitcher, of Spain, 725.
- Alderney cattle, 6128.
- Alderney, agriculture of, 7040.
- Alderney and Guernsey cattle, 7040.
- Alderson*, John, his work on agriculture, page 1168. A. D. 1802.
- Algæ, or sea weeds, their utility, 1307.
- Algiers, agriculture of, 1069.
- Alkalies, how and from what plants obtained, 1474; utility of, 1475.
- Alletz*, Pons Augustin, his work on agriculture, page 1171. A. D. 1760.
- Almond, its culture in France, 412.
- Almond, culture of, at the Cape of Good Hope, 1096.
- Aloe socotrina (figured), its culture in Spain, 702.
- Aloes, their culture and application at the Cape of Good Hope, 1097.
- Alternative medicines for live stock, 5881.
- Amazonia, agriculture of, 1218.
- Amethon*, Hubert Pascal, his work on agriculture, page 1173. A. D. 1779.
- America, agriculture of, 1130.
- Amiot*, L. P., his work on agriculture, page 1172. A. D. 1770.
- Amoretti*, —, his works on agriculture, page 1177. A. D. 1785.
- Amoreux*, —, his works on agriculture, page 1173. A. D. 1787.
- Amos*, William, his works on agriculture, page 1167. A. D. 1794.
- Amos's expanding horse-hoe and harrow, 2547.
- Amphibious animals cultivated, 6798; esculent frog, 6817; tree frog, 6818; tortoises, 6819.
- Analysis of soils, 2083.
- Anatomy and physiology of the bull family, 6227.
- Anchovy pear (figured), 1186.
- Anderson*, William, his work on agriculture, page 1170. A. D. 1816.
- Anderson*, James, L.L.D., his works on agriculture, page 1165. A. D. 1775.
- Androgynous animals, 1248.
- Andouin*, Maurice, his work on agriculture, page 1175. A. D. 1820.
- Angora goat, 6583.
- Angular sided hinged harrows, 2570.
- Angus, or Forfarshire, agricultural survey of, 7064.
- Animal chemistry, or the substances which enter into their composition, 1879; carbon, 1881; hydrogen, 1882; oxygen, 1883; azotic gas, 1884; phosphorus, 1885; sulphur, 1886; fluoric acid, 1887; muriatic acid, 1888; iodine, 1889; potash, 1890; soda, 1891; ammonia, 1892; lime, 1893; magnesia, 1894; silica, 1895; iron, 1896; manganese, 1897; compounds of organization, 1899; gelatine, 1900; albumen, 1902; fisia, 1904; extractive, 1905; mucus, 1907; urca, 1908; sugar, 1909; oils, 1910; spermaceti, 1911; ambergrease, 1912; fat, 1913; tallow, 1914; acids, 1916; fluids, 1919; solids, 1920.
- Animal food, sparing use of, by the Chinese, 983.
- Animal kingdom, study of, with reference to agriculture, 1799; systematic zoology, 1801; animal anatomy, 1806; animal chemistry, 1879; animal physiology, 1927; pathology, 1954; geographical distribution of animals, 1962; uses, 1985; culture, 1993.
- Animals, different modes of killing for use, 2046; pithing, 2047; slaughtering, 2048; Jewish modes, 2050; killing accidentally, 2051; preparation before killing, 2052.
- Animals, feeding of, for extraordinary purposes, 2038; fattening fowls for the London markets, 2040; enlarging the liver of fowls, 2041; Roman epicures, 2042; early lamb, 2043; milk and eggs, 2044; hard labor, and long journeys, 2045.
- Animals noxious to agriculture, 6846; mammalia 6847; birds, 6860; insects, 6862; worms, 6921.
- Animals of the bird kind used in agriculture, 6672.
- Animals, principles of improving the breeds of, 1994; form, 1996; lungs, 1997; chest, 1998; pelvis, 1999; head, 2000; neck, 2001; muscles, 2002; bones, 2003; nourishment, 2005; crossing, 2006; breeding in-and-in, 2014; Bakewell and Culley, 2019.
- Animals, principles of rearing, managing, and feeding, 2020; food, 2021; air and exercise, 2022, 2030; taming, 2023; feeding, 2024; mastication and cooking, 2027; salt, 2028; heat, 2029; water, 2031; tranquillity, 2033; cleanliness, 2034; comfort, 2035; health, 2036; farriery, 2037.
- Animals reared by the Romans, 148.
- Animals tender to acclimate, 6634.
- Animals, the technical description of their parts, nomenclature, and classification, 1801; descriptions, 1802; names, 1804; classification, 1805.
- Animals, their application or uses, 1985; laborers, 1986; food, 1987; clothing, 1990; medicine, 1991; arts, 1992.
- Animals, their circulating system, 1934.
- Animals, their digestive system, 1928; thirst, 1929.
- Animals, their duration, diseases, and casualties, 1954; endemical and epidemical diseases, 1956; epizooties, 1957; fasting, 1959; mutual destruction, 1959.
- Animals, their external anatomy, 1807; cuticle, 1808; mucus, 1809; corium, 1810; muscular web, 1811; cellular web, 1812; hairs, 1814; wool, 1815; feathers, 1821; horns, 1822; beaks, 1825; hoofs, 1826; claws, 1827; nails, 1828; spurs, 1829; scales, 1832; shells, 1833; crusts, 1835; secretions of the skin, 1837; sweat, 1840; carbon, 1841.
- Animals, their geographical distribution, 1962; heat, 1963; seasons, 1964, 1977; casting the hair, 1965; moulting, 1966; distribution of color in the animal kingdom, 1967; migration, 1969; birds of passage, 1971; torpidity, or hibernation, 1974; food, 1976; situation, 1979; rapacity, 1980; number of animals described, 1983; British fauna, 1984.
- Animals, their muscular structure, 1855; grasping, 1858; suction, 1859; cementation, 1860; muscular motions, 1861; standing, 1862; walking, 1863; leaping, 1868; flying, 1870; swimming, 1871; positions of sleep, 1874.
- Animals, their nervous structure, 1875; brain, 1876; functions of the brain and nervous system, 1878.
- Animals, their osseous structure, 1844; periosteum, 1845; bones, 1847; cartilage, 1850; joints, 1853; ligaments, 1854.
- Animals, their reproductive system, 1936; business of the female, 1937; of the male, 1937; viviparous animals, 1938; eggs, 1939; insects, 1941; birds, 1947; androgynous animals, 1948; gemmiparous animals, 1949; hybridous animals, 1950.
- Anotto bisca orellana* (figured), 1205.
- Anstruther*, Sir John, Bart., his work on agriculture, page 1167. A. D. 1796.
- Ant, wasp, and bee insects, 6904.
- Ant-hills, modes of removing, 5203.
- Ants, mode of poisoning in the West Indies, 1183.
- Antelope family, 6624; common, 6625; chamois, antelope, or goat, 6626; Scythian, 6627; nilgau, 6628.
- Antill*, Hon. Edward, Esq., his works on agriculture, page 1179. A. D. 1789.
- Antisocial habits of plants, its influence on their distribution, 1736.
- Anton*, K. Glo., his work on agriculture, page 1166. A. D. 1799.
- Antrim, agricultural survey of, 7107.
- Aphis or plant louse, 6884.
- Apiary, 2687.
- Apparatus for the preparation of food for cattle, 2650.

- Apples suitable for orchards, 3777, 3781.  
 April, weather and agricultural operations to be performed in, page  
 Apterous insects, 6911.  
 Aquino, Charles d', his work on agriculture, page 1177. A. D. 1736.  
 Arabia, agriculture of, 870; surface, 871; products, 872; cultivated plants and trees, 873; live stock, 874; horse, 875; implements and operations, 876.  
 Arabian horses, history of, 875.  
 Arabians, royal stud of, in France, 303.  
 Arable farming of Wiltshire, 7031.  
 Archer, Lieutenant Joseph, his work on agriculture, page 1168. A. D. 1801.  
 Arduinio, Luigi, his works on agriculture, page 1178. A. D. 1809.  
 Areca palm, culture of, in Sumatra, 1017.  
 Argyleshire cattle, 6119.  
 Argyleshire plough, 2499.  
 Argyleshire, agricultural survey of, 7072.  
 Armagh, agricultural survey of, 7105.  
 Arrow-root, *Maranta arundinacea*, culture of, in the West Indies, 1194.  
 Artificial climates, formation of, for plants, 1735.  
 Artificial springs, to form, 4156.  
 Ashes, spreading of, 2979.  
 Ashes of vegetables, how obtained, used, and the proportions afforded by different plants, 1472; analysis of ashes, 1473.  
 Ashes of soils, theory of their operation, 2137; of wood, 2179, 2238; of clover and rye-grass, 2232.  
 Asia, agriculture of, 846.  
 Asiatic islands, agriculture of, 846.  
 Asiatic Turkey, agriculture of, 847; climate, 848; mountains, 849.  
 Ass, 6087; different breeds of, 6090; training, 6093; anatomy and physiology, 6095; diseases, 6096; shoeing, 6097.  
 Ass of Persia, 859.  
 Ass among the Romans, 105.  
 Asses of Egypt, 1061.  
 Assafetida, from what plant obtained, 1456.  
*Astragalus boteticus* (figured), cultivated in Austria as a coffee plant, 617.  
 Astringent medicines for live stock, 1881.  
 Atmosphere, its influence on vegetation, 2265.  
 Auger for under-draining, 2431.  
 August, weather and agricultural operations to be performed in, page  
 Australasia, agriculture of, 1012.  
 Austria, agriculture of, 607; state of landed property, 608; management of extensive domains, 609; crown lands, 610; implements, 612; produce, 613; vine, 614; tokay wine, 614, 615; silkworm, 617; bees, 618; live stock, 619; horned cattle, 620; horses, 621; swine, 622; poultry, 623; tortoise, snail, &c., 624; forests, 626.  
 Ava, or intoxicating pepper, its cultivation in Borneo, 1021.  
 Avalanches, 333.  
 Aviary, 6795.  
 Avrouin, Foulon, his work on agriculture, page 1175. A. D. 1818.  
 Awn separating machine, 2649.  
 Axe, saw, wedge, hammer, &c., used in agriculture, 2414.  
 Ayrshire, agricultural survey of, 7055.
- B.
- Babylon, its agriculture, 136.  
 Bachapins, their agriculture, 1112.  
 Backing a horse, 5988.  
 Back-raking, an operation so called by farriers. It consists in anointing the hand very well with any sort of oil or lard, and introducing it gently into the horse's fundament, fetching out by little and little the hardened excrements, when he has got a cholic, and there is reason to suspect that it proceeds from hardened feces in the rectum. In this operation the farrier should introduce his hand and arm as far up as he well can. The properest person to do this is one who has a hand and arm of the smallest size, 5874.  
 Bacon and pork, to cure, 6576.  
 Badger, to destroy, 6353.  
 Bagging; see Reaping.  
 Bagot, his works on agriculture, page 1164. A. D. 1806.  
 Bailey, John, Esq., his works on agriculture, page 1164. A. D. 1797.  
 Baker, John Wynn, his work on agriculture, page 1165. A. D. 1771.  
 Bakewell, some account of his farm and farming, 7013.  
 Bakewell, his practice in breeding animals.  
 Bakewell's farm Dishley described, 7013.  
 Bakewell, Robert, Esq., his work on agriculture, page 1169. A. D. 1808.  
 Bakewell's improvements on live stock, history of, 765.  
 Bald, Robert, his work on agriculture, page 1170. A. D. 1812.  
 Ball, in farriery, a well known form of medicine, for horses or other animals, which may be passed at once into the stomach. It is a mode by which those substances which are in a solid state, may be thrown into the stomach, and which could not be properly effected in any other way. They should be made of a long oval shape, and about the size of a small egg, being conveyed over the root of the tongue by the hand, 3863.  
 Balls and drinks, mode of giving, to horses, 5863.  
 Balls, cordial, cough, &c., used in veterinary practice, 5889.  
 Balsams what, from what plants obtained, and how used, 1457; Benzoin, 1448; Storax, 1459; Styrax, 1460; Balsam of Tolu, 1461; Balsam of Peru, 1462.  
 Bamboo, its uses in Hindustan, 895.  
 Banana, *Musa paradisiaca* (figured), 1165.  
 Banister, John, his works on agriculture, page 1168. A. D. 1799.  
 Banks of rivers, to guard, 4058.  
 Banks, Sir Joseph, Bart. K.B., his works on agriculture, page 1168. A. D. 1803.  
 Barbaro, Marco, his work on agriculture, page 1177. A. D. 1785.  
 Barbé, Marbois, his works on agriculture, page 1174. A. D. 1798.  
 Barber, William, his works on farm buildings, page 1169. A. D. 1805.  
 Barelle, Giuseppe, his works on agriculture, page 1177. A. D. 1807.  
 Barham, Henry, his works on the silkworm, page 1163. A. D. 1718.  
 Bark for tanners, its valuation, 3767.  
 Barking trees, 3748; instruments, 3748; drying and preparing the bark, 3749.  
 Barley bread of Kircudbrightshire, 7054.  
 Barley, culture of, 4659; species and varieties, 4660; soil, 4671; sowing, 4676; harvesting, 4682; produce, 4685; uses, 4686.  
 Barns for corn, 2639; for hay, 2638.  
 Barometer, its variations in different parts of the world, 2279.  
 Barron, William, F.R.S.E., his essays on the plough, page 1165. A. D. 1774.  
 Barrows, 2449; wheel, 2449; sack, 2450; hand, 2451.  
 Bar-shoe for horses, 5932.  
 Barthez, de Marmorieres, his work on agriculture, page 1172. A. D. 1763.  
 Bartley, Nehemiah, Esq., his work on agriculture, page 1168. A. D. 1802.  
 Barton, Benjamin Smith, M.D., his work on agriculture, page 1179. A. D. 1812.  
 Bartram, Moses, his work on agriculture, page 1179. A. D. 1789.  
 Bartram, John, M.D., his work on agriculture, page 1179. A. D. 1744.  
 Baskets, 2436; seed basket, 2437.  
 Bassi, Agostino, his works on agriculture, page 1178. A. D. 1811.  
 Batchelor, Thomas, his work on agriculture, page 1169. A. D. 1804.  
 Bavaria, agriculture of, 603.  
 Beal, Dr. John, his work on agriculture, page 1163. A. D. 1679.  
 Bean, its culture, 4764; varieties, 4766; soil, 4768; sowing, 4774; harvesting, 4784; produce, 4785; use, 4790.  
 Bean dibble, 2469, 2571.  
 Bean drill, 2471, 2561.  
 Beatson's cultivator, 2538.  
 Beatson, Major General Alexander, his work on agriculture, page 1170. A. D. 1820.  
 Beaumont, Antony, his work on agriculture, page 1172. A. D. 1770.  
 Beaumont, John, his essay on cleaving of rocks, page 1163. A. D. 1684.  
 Bed in irrigation, 4087.  
 Beddoes, Thomas, M.D., his works on agriculture, page 1169. A. D. 1808.  
 Bedfordshire, agricultural survey of, 6999.

- Bee, common, 6827; apiary, 6828; varieties of bees, 6829; hives, feeding, 6833; protecting, 6834; swarming, 6835; taking the honey, 6837; partial deprivation, 6837; total deprivation, 6838, suffocation, produce and profit, 6840.  
 Bee-hives, 6830; material, 6830; size, 6831; Polish hive, 6832.  
 Bees, culture of, in North Wales, 7044.  
 Bees, culture of, in Poland, 637.  
 Bee, wasp, and ant insects, 6904.  
 Beetles, 6872; weevil, 6874; black cockroach.  
 Beetwhite or mangold, culture of, 4962.  
 Beggars of Flanders, 535.  
*Belair*, A. P. Julienne de, his work on agriculture, page 1174. A. D. 1794.  
*Belgrouc*, William, his work on agriculture, page 1179. A. D. 1755.  
*Bell*, Benjamin, F.R.S.E., his work on agriculture, page 1168. A. D. 1802.  
 Belly, diseases of, 5791.  
 Bend in irrigation, 484.  
*Beneš*, Sir Richard, his work on agriculture, page 1162. A. D. 1535.  
*Benetti*, Santo, his work on agriculture, page 1178. A. D. 1810.  
 Benin, agriculture of, 1080.  
*Benyon*, William, A.M., his work on agriculture, page 1164. A. D. 1724.  
 Berkshire waggon, 2622.  
 Berkshire, agricultural survey of, 7005.  
*Berthezen*, S., his work on silkworms, page 1166. A. D. 1789.  
*Berthelot*, his work on agriculture, page 1173. A. D. 1782.  
*Bertochus*, Dionysius, his work on agriculture, page 1177. A. D. 1496.  
*Bertrand*, his work on agriculture, page 1174. A. D. 1794.  
*Bertrand*, Jean, his work on agriculture, page 1172. A. D. 1764.  
*Bertrand*, Elie, his works on agriculture, page 1172. A. D. 1764.  
 Berkshire, agricultural survey of, 7049.  
 Besoms, 2395.  
 Betel leaf, piper betle (figured), its culture and preparation in Sumatra, 1016.  
 Beverston wheel-plough, 2512.  
*Bezon*, Gabriel Leopold Charles Ame, his works on agriculture, page 1172. A. D. 1773.  
 Bibliography of agriculture in foreign countries, 7111.  
 Bibliography of French agriculture, 7112.  
 Bibliography of German and Italian agriculture, 7113, 7114.  
 Bibliography of Spanish and Portuguese agriculture, 7116.  
 Bibliography of Flemish and Dutch agriculture, 7117.  
 Bibliography of Swedish and Danish agriculture, 7118.  
 Bibliography of Polish and Russian agriculture, 7119.  
 Bibliography of British agriculture, 7110.  
 Bibliography of American agriculture, 7120.  
*Bidct*, M., his work on agriculture, page 1177. A. D. 1778.  
*Billingsley*, John, Esq., his work on agriculture, page 1163. A. D. 1798.  
 Binot or ribbing plough, 2501.  
 Binot, an agricultural implement of Flanders, 500.  
 Birch-wine, how obtained and manufactured in Derbyshire, 7014.  
 Birds, singing, to rear, 6793; curious or remarkable birds, 6796.  
 Birds injurious to agriculture, 6860; kite, 6860; crow, 6861; granivorous birds, 6861.  
 Birds employed in agriculture, 6672.  
 Birds of luxury cultivated by farmers, 6763.  
 Birds of Amazonia, 1218.  
 Birdsfoot trefoil, 5083.  
*Birkbeck*, Moris, Esq., his works on agriculture, page 1170. A. D. 1815.  
 Birman empire, agriculture of, 921.  
*Biroli*, Giovanni, his works on agriculture, page 1177. A. D. 1807.  
 Bitter, principle, from what plants obtained, and how used, 1395.  
 Black soil, its influence in absorbing heat, 2108.  
*Black*, James, his work on agriculture, page 1163. A. D. 1778.  
 Blackwater in cattle, 6263.  
 Bladder, inflammation of, in cattle, 6264.  
 Bladder, inflammation of, 5814.  
*Blaike*, Francis, his works on agriculture, page 1163. A. D. 1819.  
*Blaike's* inverted horse-hoe, 2544.  
 Blanks in plantations to fill up, 3683.  
 Blast or hove in sheep, 6511.  
*Blauet*, his work on agriculture, page 1171. A. D. 1755.  
 Bleeding horses, 5878.  
 Blight in plants, 1653; from cold and frosty winds, 1655; from vapor, 1656; from fungi, 1657.  
 Blistering, 5870; sweating or liquid blisters, 5872.  
 Blisters used in veterinary practice, 5890.  
*Blith*, Walter, his works on agriculture, page 1163. A. D. 1649.  
 Block plough drill, 2562.  
 Blood or bog spavin, 5841.  
 Blood, theory of its operations as a manure, 2188.  
 Blood rot in sheep, 6513.  
 Blood ray; see Dysentery, 6267.  
 Bloody urine in horses, 5815.  
 Blown or hove in cattle, 6258.  
 Boabab tree, *Adansonia digitata*, 1083.  
 Bog of Allan in Ireland, 807.  
 Bog meadows, their management, 5213.  
 Bog spavin, 5841.  
 Bogs of Ireland, 807.  
 Bogs, to improve, 4183.  
 Bombyx mori (figured), silk moth, its culture in France, 409.  
 Bone spavins and splints, 5838.  
 Bones, their nature and uses, 1845.  
 Bones, grinding of, for manure in Derbyshire, 7014.  
*Bonnemain*, his work on agriculture, page 1174. A. D. 1816.  
*Bonner*, James, his plan for beehives, &c., page 1167. A. D. 1795.  
 Book farmers, or ærialists, 7045.  
 Books of accounts for farmers and bailiffs, 4509.  
*Booker's* lime-kiln, 3589.  
 Bootan, agriculture of, 1007.  
*Borche*, H. A. Grafen, Count de, his work on agriculture, page 1176. A. D. 1779.  
*Bordley*, J. B., his work on agriculture, page 1179. A. D. 1801.  
 Borer of soils, 2428; of peat, 2430; draining auger 2431.  
 Boring for water, 4148; at Tottenham, at Ravenscroft park, 4148.  
 Borno, agriculture of, 1020.  
*Bornot*, M.A., his work on agriculture, page 1175. A. D. 1817.  
*Borro* (del) Alessandro, his work on agriculture, page 1177. A. D. 1718.  
*Bosc*, his works on agriculture, page 1175. A. D. 1823.  
*Bosc*, K. Ad. H. von, his work on agriculture, page 1176. A. D. 1792.  
*Boswell*, George, his work on agriculture, page 1166. A. D. 1780.  
*Boucher*, d' Argis, Antoine Gaspard, his work on agriculture, page 1171. A. D. 1749.  
*Bouthier*, his work on agriculture, page 1173. A. D. 1780.  
 Bowles, inflammation of, 5797.  
*Boys*, John, his work on agriculture, page 1767. A. D. 1796.  
 Brabant scythe in use in Flanders, 503.  
*Bradley*, Richard, F.R.S., &c., his works on agriculture, page 1163. A. D. 1721.  
 Brake or levelling harrow, 2573.  
 Braxy or dysentery in cattle, 6267.  
 Braxy in sheep, 6515.  
 Brazil, agriculture of, 1207; vegetable productions, 1208; lines, 1208; ipeacuanha, 1209; pot tree, 1210; pine apples, 1211; mandiocca, 1212; live stock, 1213; muck ox, 1214.  
 Bread fruit of Otaheite (figured), 1037.  
 Breaking and training cattle among the Romans, 98.  
 Breaking machine for roots, 2474.  
 Breaking stones, 2885.  
 Breast hoe, or breast plough, 2391.  
 Breeds of animals, how to improve; see Animals 1994.  
 Breeding farms, 5974.  
 Breeding of horned cattle, 6144.  
 Breeding stock, choice of, 4470; Cline's opinions, 4476.  
 Breeding among the Romans, 94.  
 Breeding in-and-in, physiologically considered, 1014.  
 Brewery and distillery plants, substitutes for, 5456.

- Bridge, portable, for live stock, 6996.  
 Bridle sores, 5778.  
 Britain, agriculture of, after the Norman conquest, 204.  
 Britain, agriculture of, from the fifth to the seventeenth century, 195.  
 Britain, agriculture of, during the Anglo-Saxon dynasty, 196.  
 British isles, modern agricultural history of, 741; political history, 742; professional history, 753; literary history, 781.  
 British fauna, or catalogue of British animals, 1984.  
 British North America, agriculture of, 1166; Canada, 1167.  
 British flora, distribution of, 1759; perfect plants, 1761; imperfect plants, 1762; introduction of exotics, 1770; purchasable plants, 1772.  
 Broken wind, 5789.  
 Broken knees in horses, 5837.  
 Broom, field culture of, 5080.  
 Broussonet, Pierre-Marie-Auguste, his works on agriculture, page 1173. A. D. 1787.  
 Brown, Robert, his works on agriculture, page 1168. A. D. 1799.  
 Brugnone, Gio, his works on agriculture, page 1177. A. D. 1781.  
 Bruising machine, 2467.  
 Buchoz, Pierre Joseph, his works on agriculture, page 1171. A. D. 1760.  
 Buckinghamshire, agricultural survey of, 6998.  
 Buckwheat, 4736. 5499.  
 Buckwheat, culture of, in Flanders, 456.  
 Budding plants, 1621.  
 Buffalo, 6279.  
 Buffalo of Hindustan, 898.  
 Buffalo of Egypt, 1059.  
 Buliard, his work on agriculture, page 1173. A. D. 1778.  
 Bull or ox family, 6105; see Ox.  
 Bull family, anatomy and physiology of, 6227.  
 Bunias orientalis (figured), culture of, 5084.  
 Buns, the stalks of hemp from which the bark or woody matter has been taken off, 5334.  
 Buonaparte, agricultural societies, &c., established by him, 376.  
 Burnet, culture of, 5064.  
 Burning clay, operation of, 2981; theory of burnt clay as a manure, 2982; common method by kilns, 2985; improved method, 2987; burning with quicklime, 2989.  
 Burroughs, Edward, Esq., his work on agriculture, page 1170. A. D. 1820.  
 Bush harrow, 2576.  
 Bushmans, their agriculture, 1113; spade, 1113.  
 Bustard, *Otis tarda*, 6756; little bustard, *O. tetrax*, 6756.  
 Butler, Charles, his work on bees, page 1162. A. D. 1609.  
 Butter, making and curing of, 6320.  
 Butter of Epping, 6187.  
 Butterflies, 6889; chrysalis state, 6891; perfect insect, 6892; British butterflies the most remarkable, 6893.  
 Buttermilk, 6379.
- C.
- Cabbage tribe, field culture of, 4969.  
 Cabbage, its culture and application in China, 980.  
 Cabbage tree of the Pellew isles (figured), 1030.  
 Cabbage tree beetle of Surinam (figured), 1217.  
 Cactus opuntia (figured), Indian fig, 703.  
 Cadet de Vaux, Antoine Alexis, his works on agriculture, page 1173. A. D. 1782.  
 Caithness, agricultural survey of, 7069.  
 Calendarium floræ, principles of forming, 1629; uses of, 1630.  
 Calf pens, 2678.  
 Calkins, or turn-ups, in frost-shoeing of horses, 5937.  
 Caloric, how distributed in the animal kingdom, 1967.  
 Calthorpe, Charles, his work relative to the lord of a manor and his tenant, page 1162. A. D. 1635.  
 Calvel, Etienne, his work on agriculture, page 1174. A. D. 1809.  
 Calves, fattening of, 6187.  
 Calves, diseases of, 6278.  
 Calving, 6276.  
 Cambodia, agriculture of, 945.  
 Cambridgeshire, agricultural survey of, 7001.  
 Camel of Persia, 859.  
 Camel of Hindustan, 904.  
 Camel family, 6630; dromedary, Arabian, Bactrian, 6630; lama, 6631.  
 Camellia sasanqua, one of the tea plants of China, 965.  
 Camellia bohea, black tea of China, 962.  
 Camellia viridis, green tea of China, 962.  
 Camellia oleifera, oil-bearing tea plants, 967.  
 Camelpard, 6632.  
 Camphire tree, and its application in China, 971.  
 Camphor, from what plant obtained, how, and its uses, 1463.  
 Campo morto, farm of, near Rome, 303.  
 Canada, agriculture of, 1167; soil, 1168; products, 1169.  
 Canals, their formation, 3526; utility, 3527; line or route, 3533; canal companies, 3539; execution of the works, 3544.  
 Canals and embankments of modern Egypt, 1048.  
 Canary grass, 5485.  
 Canary islands, agriculture of, 1120.  
 Canciana, his work on agriculture, page 1177. A. D. 1776.  
 Canker in the feet of horses, 5858.  
 Canine madness, 6660; raging madness, 6661; dumb madness, 6662; preventive treatment, 6663.  
 Canis, or dog family, 6635; see Dog.  
 Cantuni, Carlo Antonio, his work on agriculture, page 1177. A. D. 1778.  
 Caoutchouc, or India rubber, from what plants obtained, and how, 1464.  
 Cape of Good Hope, agriculture of, 1087; climate, 1088; surface, 1089; soil, 1090; landed property, 1091; farms, 1092; products, 1093; vine, 1094; Constantia wine, 1095; almond, 1096; aloe, 1097; tobacco, 1098; live stock, 1099; implements and operations, 1106; agriculture of the native tribes, 1108; of the unimproved Hottentots, 1109; Hottentot huts and cattle, 1109, 1110; bachapins, 1112; Bushmans, 1113.  
 Cape Verd islands, agriculture of, 1119.  
 Cape Breton, agriculture of, 1171.  
 Capparis spinosa (figured), the caper plant, its culture in France, 384, 413.  
 Caprification of the fig in Turkey, 732.  
 Capulet of the hock in horses, 5843.  
 Carbon, as an article of vegetable food, 1510.  
 Carbonic acid gas in the atmosphere, 2271.  
 Carlow, agricultural survey of, 7083.  
 Carolines, agriculture of, 1032.  
 Caronelli, Pietro, his works on agriculture, page 1177. A. D. 1791.  
 Carp, 6801.  
 Carpenter, J., his work on agriculture, page 1169. A. D. 1803.  
 Carradori, Groachino, his work on agriculture, page 1177. A. D. 1803.  
 Carraway, 5452.  
 Carrera, Antonio, his work on agriculture, page 1177. A. D. 1780.  
 Carriage in irrigation, 4077.  
 Carrot, its culture, 4926; varieties, 4927; soil, 4928; sowing, 4935; taking the crop, 4942; produce, 4944; use, 4945.  
 Carrot, culture of, in Flanders, 467.  
 Carse lands of Stirlingshire, 7058.  
 Cart of Hindustan, 907.  
 Cart of Paris, 398.  
 Cart of Russia, 662.  
 Cart of Rome, 302; of Flanders, 507; of France, 398.  
 Cart, Scotch (figured), 770.  
 Cart of modern Greece, 736.  
 Cart-sheds, 2707.  
 Carts, 2608; for one or two horses, 2609; Scotch one-horse cart, 2611; Scotch two-horse cart, 2612; improved two-horse carts, 2613; corn cart, 2614; dray cart, 2615; quarry cart, 2617; three-wheel cart, 2618.  
 Carts of Yorkshire, 7021; figs. 794 and 795.  
 Carter, Landon, his work on agriculture, page 1179. A. D. 1789.  
 Carthage, its agriculture, 38.  
 Carthamus tinctorius, cultivated in Egypt, 1057.  
 Carver, Jonathan, Esq., his work on agriculture, page 1179. A. D. 1779.  
 Cassava or manioc, *Jatropha manihot*, 1116.  
 Castellet, Constans, his work on agriculture, page 1177. A. D. 1778.  
 Castelli, Benedict, his work on agriculture, page 1177. A. D. 1628.  
 Casting, the operation of throwing a horse down: it is done as follows: having brought him upon

- some even ground that is smooth and soft, or into the barn upon soft straw, take a long rope, double it, and cast a knot a yard from the bow; put the bow about his neck, and the double rope betwixt his fore legs; about his hinder pasterns, and under his fetlocks: when you have done this, slip the ends of the rope underneath the bow of his neck, and draw them quick, and they will overthrow him; then make the ends fast; and hold down his head, 5861.
- Castor wheel horse-hoe, 2548.
- Castration, docking, nicking, and cropping, 5877.
- Casualties of animals, 1954.
- Cat, *Felis catus*, 6668.
- Catarrh or influenza in cattle, 6248.
- Catarrhal fever in horses, 5765.
- Catch drain in irrigation, 4086.
- Catch-work meadows, 4095.
- Caterpillars, different sorts, 6866; gooseberry, 6920.
- Cato, M. Porcius, his works on agriculture, 45.
- Cattaneo, Giacomo, his work on agriculture, page 1177. A. D. 1767.
- Cattle of Aberdeenshire, 7066.
- Cattle surgery, 6272.
- Cattle hampels and sheds, 2677.
- Cattle obstetrics, 6275.
- Cattle of Piedmont, careful mode of feeding, 269.
- Cattle of Devonshire, 7038.
- Cavan, agricultural survey of, 7099.
- Cavendish, William, Marquess and Duke of Newcastle, his work on horses, page 1163. A. D. 1667.
- Cavia cobaya, or Guinea pig, 6614.
- Cavy; see Cavia, 6614.
- Cayenne, agriculture of, 1215.
- Celebezan islands, agriculture of, 1023.
- Cels, Jacques Martin, his works on agriculture, page 1174. A. D. 1795.
- Cerantia siliqua, the carob bean, or St. John's bread, or locust tree of the bible (figured), 1078.
- Cereal grasses, culture of, 4596.
- Cervus, the deer family, 6616; C. elephas, 6617; C. capreolus, 6618; C. dama, 6619; C. alices, 6622; C. tarandus, 6623.
- Ceylon, agriculture of, 914; soil, 915; cultivation, 916; implements, 917; farm yard, 918; embankment, 919.
- Chabert, Philippe, his works on agriculture, page 1173. A. D. 1785.
- Chaffcutter, 2466.
- Chambray, Louis, marquis de, his work on agriculture, page 1172. A. D. 1765.
- Chamerops humilis, the fan palm, its culture in Spain, 704.
- Chamois goat, *Antelope rupicapra*, 6626.
- Chamomile, 5523.
- Chamomile, culture of, in Derbyshire, 7014.
- Chanvallon, his work on agriculture, page 1172. A. D. 1769.
- Chaptal, Comte, his work on agriculture, page 1175. A. D. 1823.
- Charcoal, what, how manufactured; in what proportions afforded by different plants, 1467; properties of charcoal, 1468.
- Chatelein, Le Chevalier, his work on agriculture, page 1175. A. D. 1816.
- Cheese, Gruyère, how made in Switzerland, 342.
- Cheese-making, process of, 6335.
- Cheese-making in Cheshire, 7028.
- Cheese mite, 6913.
- Cheese presses, 6310.
- Cheese, Parmesan, how made in Lombardy, 270.
- Chemical analysis of soils, 2083.
- Chemistry of animals, 1879.
- Chermes insect, or plant louse, 6885.
- Cherries suitable for orchards, 3788.
- Cheshire, agricultural survey of, 7028.
- Chicory, 5503.
- Chicory, culture of, 5074; in Italy, 273.
- Chili, agriculture of, 1204; plants, 1205.
- Chillingham castle, wild breed of cattle at, 6130.
- Chinese Tartary, agriculture in, 1005.
- Chinese corn mill, 913.
- Chinese empire, agriculture of, 951; Dr. Abel's opinion of Chinese agriculture, 952; Dr. Barrow's, 953; Livingstone's, 954; climate, 955; surface, 956; soil, 957; landed property, 958; agricultural products, 959; tea districts, 960; oil plants; 967; tallow tree, 968; wax tree, 969; camphire tree, 971; oak, 972; maiden-hair tree, 973; cordage plant, 974; cotton, 975; silk worm, 975; groundnut, 977; water chestnut, 978; millet, 979; cabbage, 980; live stock, 982; wild animals, 984; birds, 985; fisheries, 986; implements, 967; operations, 988; tillage, 989; manures, 991; retiring houses, 999; terrace cultivation, 1001; forests, 1003; row culture general, 1002; national agricultural fête, 1004.
- Chocolate tree, *Theobroma* (figured), 1206.
- Christ, J. L., his work on agriculture, page 1176. A. D. 1780.
- Chronic cough, 5788.
- Chronic founder in the feet, 5850.
- Churning, process of, 6322.
- Churns, different kinds of, 6311.
- Circulating system of animals, 1934.
- Cicer arictinum (figured), the chick pea, 406.
- Cichorium intybus (figured), chicory, cultivated as an herbage plant in Italy, 273.
- Cider, its manufacture, 3809; gathering the fruit, 3810; mixing, 3811; grinding, 3812; pressing, 3815; fermenting, 3816; barreling, 3817; stumming, 3820; bottling, 3821; machinery and utensils, 3824; mills, 3826; press, 3831; cloths, 3832; vats, 3833; casks, 3834.
- Cider mills, different kinds of, 3826.
- Cinnamon, *Laurus canella*, 1208.
- Citron, as grown in Persia, 1506.
- Cistus, *ladaniferus* (figured), Gum cistus, its use in Spain, 710.
- Clackmannanshire, agricultural survey of, 7060.
- Clap or strain in the back sinews of horses, 5833.
- Clare, agricultural survey of, 7092.
- Claridge, John, his work on agriculture, page 1166. A. D. 1793.
- Claridge, John, his work on the changes of the weather, page 1164. A. D. 1744.
- Clark, John, F.S.A., his works on agriculture, page 1167. A. D. 1794.
- Clarke, Charles, his treatise on gypsum, page 1166. A. D. 1792.
- Clarke, Cuthbert, his work on agriculture, page 1167. A. D. 1777.
- Clarke's draining plough, 2519.
- Classification of soils, 2067; by Sir H. Davy, 2068; by Thaer, Thouin, and Fellenberg, 2070.
- Claveau, or sheep pox, 6505.
- Clay, to dry and burn, 2981.
- Cleghorn, James, his work on agriculture, page 1171. A. D. 1822.
- Cleaning roots, 2901.
- Cleaning cattle, 2994.
- Climate in respect to the culture of vegetables, 1790.
- Climate of Britain, study of, 2369.
- Cline, Henry, Esq., his theory of improving the breed of animals, 2014.
- Clipping, 2919.
- Cluquot, Blerivache, his work on agriculture, page 1173. A. D. 1789.
- Clothing arts, plants grown for, 5291.
- Clotted cream, 6375.
- Clouds, their effects relating to the atmosphere and vegetation, 2249.
- Clouds, their nomenclature, by Luke Howard, 2289.
- Clover family, culture of, 4985; species and varieties, 4986; soil, 4992; sowing, 4995; taking the crop, 5003; making into hay, 5006; produce, 5018; seed, 5021.
- Clover and turnips, their introduction, as agricultural plants, into England, 235.
- Clydesdale, agricultural survey of, 7056.
- Clymer's plough, 2505.
- Clystering in veterinary surgery, 5874.
- Clysters used in veterinary medicine, 5895.
- Coal mines, 3580.
- Coal strata of Durham, 7023; fig. 796.
- Cob, a kind of wicker basket, made so as to be carried on the arm. Hence a seed-cob, or seed-lip, is a basket for sowing from, 2437.
- Cochin China, agriculture of, 944.
- Cochineal, culture of, in Mexico, 1164.
- Cochineal, or coccus insect, 6887.
- Cochrane, Archibald, Earl of Dundonald, his works on agriculture, &c., page 1167. A. D. 1795.
- Cockburn, of Ormiston, a great improver, 772.
- Cock-roach, 6878; black-beetle, 6879.
- Cocoa tree, *Cocos nucifera* (figured), its culture and application in Hindustan, 888.
- Cocoa root, or eddoes, *Arum* and *Caladium*, various species, culture of, in the West Indies, 1192.
- Cock and hen, 6683; game cock and hen, 6684; Dorking variety, 6685; Poland cock and hen, 6686; every-day, 6687; bantam, 6688; Chittagong or Malay, 6689; shacklebag, or Duke of Leeds, 6690; Spanish, 6691; breeding of gallinaceous poultry, 6692; general management, 6693; moulting, 6700; hatching, 6702; products, 6706; fat-

- tening, 6710; different sorts of food, 6714. Craming, different modes of, 6718; pinioning, 6723.
- Coffee, culture of, in Java, 933.
- Coffee tree (figured), culture of, in the West Indies, 1900.
- Coffee plants of Austria, 617.
- Coffin joint, strains of, in horses, 5835.
- Cointereaux, Francois, his works on agriculture, page 1173. A. D. 1792.
- Cold, theory of excluding, by slight coverings, 2254.
- Coleopterous insects injurious to agriculture, 6871.
- Colerus, J., his works on agriculture, page 1175. A. D. 1591.
- Colic in horned cattle, 6265.
- Colic, gripes, fretor gullion, 5805.
- Colic red, or interitis, 5797.
- Coloring matter of plants, how obtained and used, 1388; blues, 1389; reds, 1390; yellows, 1391; browns, 1392.
- Cotte, L., his work on agriculture, page 1173. A. D. 1790.
- Colts, deceptions practised with by horse dealers, 5958.
- Columba, the pigeon, 6764.
- Columela, L. J. Moderatus, his works on agriculture, 48.
- Comber, Thomas, L.L.D., his works on agriculture, page 1165. A. D. 1770.
- Combles, a mode of warping practised in Italy, 267.
- Common drill barrow, 2470.
- Common field, laying out of, 4213.
- Commonable lands, their origin and kinds, 3234; principles of appropriating and dividing, 3247.
- Comparetti, his work on agriculture, page 1177. A. D. 1798.
- Composts, their formation and uses, 4593; meadow bank middens, 4595.
- Condition of horses, 5754.
- Congo, agriculture of, 1082.
- Constantia wine, history of, at the Cape of Good Hope, 1094.
- Contraction in the feet, 5851.
- Conversion of grass lands to arable, 5261; rotation of crops, 5279.
- Convolvulus batatas (figured), Spanish or sweet potatoes, 238.
- Convolvulus edulus, cultivated in Japan for its tubers, 949.
- Cooke, James, his work on agriculture, page 1166. A. D. 1784.
- Cooke's corn drill, 2552; three-row drill, 2554.
- Coops for poultry, 6679.
- Coolie, Sir Charles, Bart., his works on agriculture, page 1168. A. D. 1801.
- Copineau, Abbé, his work on agriculture, page 1173. A. D. 1780.
- Coppice woods of Flanders, 529.
- Coppice woods, season and modes of cutting and managing, 3739.
- Cordage plant of China, *Sida tiliaefolia*, 974.
- Coriander, 5449.
- Cork, what, from what plants obtained, how manufactured and used, 1465.
- Cork-tree in Spain, 726.
- Cork, agricultural survey of, 7089.
- Corn stands, 2746.
- Corn, its preservation in granaries or other stores, principles of, 1797.
- Corn screen, 2435.
- Corn drills, 2552.
- Corn barn, 2689; English corn barn, 2690; threshing floor, 2691; threshing mill barn, 2697.
- Corn, invention of its culture, 11.
- Corn measures, 2443.
- Corn bin, 2441.
- Corn sacks, 2444.
- Corn laws, history of, 742.
- Corn laws first introduced in England, 240.
- Corns in the feet of horses, 5853.
- Cornwall, agricultural survey of, 7039.
- Corstorphin cream, 6373.
- Costa, Ch., his work on agriculture, page 1176. A. D. 1802.
- Cottage buildings, their arrangement, 3872; tradesman's cottage, 3873, 3878; double cottages, 3874, 3876; cottages for laborers, with cow-house and piggerly, 3877; picturesque cottages, 3879; entrance lodges, 3880.
- Cottage gardens of Cheshire, 7028.
- Cottage gardens, premiums for their cultivation in Buckinghamshire, 6998.
- Cottage huts of Finland and Lapland, 671.
- Cottage system on the Trentham estates, 7011.
- Cottage system of East Lothian, 7048; of Berwickshire, 7049.
- Cottage lands, to lay out, 3835; size, 3836; cottage farms, 3839.
- Cottage or cabin of Ireland, 815.
- Cottages of Egypt (figured), 1062.
- Cottages, their establishment on estates, 3569.
- Cottages of Flanders, 538.
- Cottages of Sweden, 671.
- Cottages of Nubia, 1065.
- Cottages in Switzerland, 335.
- Cottages of China, 956.
- Cottages of Moldavia, 739.
- Cottages of Ayrshire, 7055; fig. 812.
- Cottages of Berkshire, 7005; fig. 777.
- Cottages of Kincardineshire, 7065.
- Cottages of West Lothian, 7059; fig. 814.
- Cottages of Cornwall, 7039.
- Cottages of Dumfriesshire, 7053.
- Cottages for farm-servants, 2718; accommodation, 2719, 2720; smallest size, 2720; double cottage and cow-house, 2721; Wood's seven principles for constructing cottages, 2722; walls of cottages, 2731; stairs, 2732; ornamental cottages, 2734.
- Cotton plant, culture of, in Jamaica, 1188.
- Cotton, culture of, in Sumatra, 1019.
- Cotton plant, *Gossypium herbaceum* (figured), culture of in Italy, 318.
- Cotton plants of China, 975.
- Couch grass rake, 2595.
- Cough in sheep, 6509.
- Cough, chronic, 5788.
- Course of a river, to change, 4045.
- Covenry, Andrew, Esq., M.D., his works on agriculture, page 1169. A. D. 1808.
- Covers for stacks, 2750.
- Cow, criteria of one of superior excellence, 6138.
- Cow, club for purchasing, 7022.
- Cow of Tunis (figured), 1068.
- Cows for the dairy, management of, 966.
- Coze, Daniel, M.D., his work on agriculture, page 1163. A. D. 1674.
- Cracks and grease in horses, 5845.
- Cramer, John Andrew, his work on agriculture, page 1176. A. D. 1766.
- Crane fly, or wire worm, 6907.
- Craw or cray fish, 6841.
- Cream, different preparations of, 6369.
- Crescentius, Crescenzio, or de Crescentiis, his works on agriculture, page 1177. A. D. 1471.
- Cress, 5501.
- Cricket, 6881.
- Cromarty, agricultural survey of, 7068.
- Crone, an old ewe, 6413.
- Cropping, nicking, and docking in horses, 577.
- Crops, rotation of, for different soils, 4549; strong deep lands, 4558; their clays, 4561; peat soils, 4562; light soils, 4563.
- Crops cultivated by the Romans, 148; cereal grasses, 148; legumes, 149; herbage plants, 150; manufactory plants, 152; ligneous crops, 153; fruits, 154.
- Crossing the breed of animals, physiologically considered, 2006.
- Croton sebiferum, the tallow tree of China, 968.
- Crud, Le Baron, E.V.B., his work on agriculture, page 1175. A. D. 1820.
- Cuba, agriculture of, 1173.
- Cuckoo spit, Cicada, 6883.
- Cud, loss of, in cattle, 6269.
- Culinary vegetables, culture of, in Flanders, 485.
- Culley, George, his works on agriculture, page 1166. A. D. 1786.
- Culley, George, his practice in breeding animals, 2015.
- Cultivated lands, to improve, 4207; farms and farm lands, 4210.
- Cultivating the soil with pronged implements, 3019.
- Cultivators, 2527.
- Culture, its general effect on vegetables, 1730; on culinary vegetables, 1731; fruits, 1732; plants of ornament, 1733.
- Culture of corn, its invention, 11.
- Culture of grasses, 5086.
- Cumberland, agricultural survey of, 7025.
- Curb of the hock in horses, 5843.
- Curds and cream, 6371; curds and whey, 6370.
- Curtis, William, his work on agriculture, page 1166. A. D. 1790.
- Curwen, John Christian, M.P., his works on agriculture, page 1169. A. D. 1809.
- Cuscuta europæa, or dodder (figured), 172.
- Custard apple, *Anona tripetala*, (figured), 1165.



- Cutting in the feet of horses, 5860.  
 Cutting, 2915; draw cuts, 2916; pruning, 2917.  
*Cyperus esculentus* (figured), cultivated in Austria as a coffee plant, 617.  
*Cyprinus auratus*, or gold fish in China, 986.
- D.
- Dairy and its management, 6282; principles of milk, 6284; dairy house, furniture, and utensils, 6297; milking and management of milk, 6315; making and curing butter, 6320; cheese-making, 6335; catalogue of cheeses and other products of milk, 6349.  
 Dairy house, different plans for, 6300.  
 Dairy furniture, 6297.  
 Dairy utensils, 6297.  
 Dairy at Woburn, 6999; fig. 775.  
 Dairy, management of, Gloucestershire, 7006.  
 Dairy cows, management of, 966.  
 Dairy of Ireland, 829.  
 Dairy of Switzerland, 342.  
 Dairy, its economy, 5546.  
 Dairies of Lombardy, 270.  
 Dairies, public, in Savoy, 359.  
 Dairies of Flanders, 516.  
 Dairies of France, 394.  
 Daisey, or staggers in cattle, 6270.  
*Dalrymple*, William, Esq., his work on agriculture, page 1168. A. D. 1800.  
*Dandolo*, Vincenzo, his works on agriculture, page 1178. A. D. 1812.  
 Dartmoor, forest of, 7038.  
*Darwin*, Erasmus, M.D., F.R.S., his work on agriculture, page 1168. A. D. 1800.  
 Date tree, its culture and uses in Hindustan, 894.  
*Daubenton*, Jean Louis Marie, his work on agriculture, page 1174. A. D. 1802.  
*Davis*, Thomas, Esq., his work on agriculture, page 1167. A. D. 1794.  
*Davis*, Richard, his work on agriculture, page 1167. A. D. 1794.  
*Davis*, of Longleat, his opinions as to horses for labor, 449.  
*Davies*, Walter, A.M., his work on agriculture, page 1169. A. D. 1810.  
*Davy*, Sir Humphry, Pres. R.S., L.L.D., V.P.R.I., F.R.S., Edin. M.R.I.A., &c., his elements of agricultural chemistry, page 1170. A. D. 1813.  
*Dawson*, Wm. Esq., of Graden, (the father of the turnip husbandry of the North, was born at Harperton in Berwickshire, in 1734, in the same parish which gave birth to the poet Thomson. He went to England at the age of 16, and studied the agriculture of Norfolk for nine years. In 1759 he returned, and took a lease of the farr of Frogden in Roxburghshire. He there introduced the culture of turnips in drills, the practice of ploughing with two horses without a driver, and a better mode of applying lime to lands; improvements of incalculable importance. This benevolent character maintained teachers for the children of his farm-servants at his own expence. In 1814, was published his "Causes of the Poverty of Nations," a work which proves the soundness of his principles in political economy. He died in July, 1815, in his 81st year. (See *F. Mag.* vol. xvi. p. 163.) 780. 4591. 7024.  
 Day fly, 6398.  
 Day laborers of Flanders, 534.  
*Dean*, Dr., his work on agriculture, page 1179. A. D. 1790.  
*De Breze*, his work on agriculture, page 1172. A. D. 1769.  
 December, weather and agricultural operations to be performed in, page 1193.  
 Deceptions practised by dealers as to the ages of horses, 5958.  
 Decortication of trees, 1649.  
 Decoys for wild ducks, how to form, 6743; pipe, 6745; management, 6744.  
 Deer family or cervus, 6616; see Cervus.  
 Deer, to fatten, 6620.  
 Deer, to castrate, 6621.  
 Deer husbandry, 6620.  
 Demesne lands, choice of site for, 3263.  
 Denmark, agriculture of, 558; landed property, 558; farm houses, 559.  
*Depradt*, D., Archbishop of Molines, his work on agriculture, page 1174. A. D. 1803.  
*Der Schwitzer*, his work on agriculture, page 1175. A. D. 1760.  
 Derbyshire, agricultural survey of, 7014.  
*Desbois*, Francis Alexander Aubert de la Chesnaie, his work on agriculture, page 1171. A. D. 1751.  
*Deslandes*, his work on agriculture, page 1175. A. D. 1820.  
*Desplaces*, Laurent Benoit, his works on agriculture, page 1172. A. D. 1762.  
*Despommiers*, his work on agriculture, page 1172. A. D. 1762.  
*Destere*, his work on agriculture, page 1179. A. D. 1800.  
 Detached property, to consolidate, 3228.  
 Devonshire, agricultural survey of, 7038.  
 Devonshire cream, 6374.  
 Devonshire cattle, 6112.  
 Dew, theory of, by Dr. Wells, 2297.  
 Diabetes, profuse staling or pissing evil, 5816.  
 Diarrhœa or looseness, 5804.  
 Diarrhœa in horned cattle, 6266.  
 Dibber, potatoe, 2397; common, 2398.  
*Dickson*, R. W., M.D., his works on agriculture, page 1169. A. D. 1804.  
*Dickson*, the Rev. Adam, A.M., his translations of the Roman agricultural authors, 52; his works on agriculture, page 1164. A. D. 1762.  
 Digestion in animals, physiologically considered, 1923.  
 Digging, 2887.  
 Digging or forking up crops, 2945.  
*Digitaria sanguinalis* (figured), or Polish millet, its culture, 4726.  
 Dipterous insects, 6905.  
 Directive language used to horses, 5985.  
 Diseased feet, shoeing of, 5938.  
 Diseases of the horse, 5754; see Horse, diseases of.  
 Diseases of the feet in horses, 5843; founder, 5850; contraction, 5851; pumiced foot, 5852; corns, 5853; running thrush, 5855; sand cracks, 5856; pricks, 5857; quitter and canker, 5855; treads, 5859; cutting, 5860.  
 Diseases of the hop, 5440; the flea, 5441; fly, 5442; moth, 5443; honey dew, 5444; mildew, 5445; blights, 5446; fire-blast, 5447.  
 Diseases of plants, 1652; blight, 1653; from cold and frosty winds, 1655; vapor, 1656; fungi, 1657; smut, 1658; mildew, 1659; honey dew, 1660; dropsy, 1662; flux of juices, 1664; chilblains, 1668; gangrene, 1669; etiolation, 1671; suffocation, 1672; contortion, 1677; consumption, 1679.  
 Diseases of poultry, 6757; catarrh, 6759; fractures, 6760; gargle, 6761; vermin, 6762.  
 Diseases of horned cattle, 6244.  
 Diseases of calves, 6278.  
 Diseases of animals, physiologically considered, 1954, 1960.  
 Dishley sheep, 6393.  
 Dishley, the farm of the Bakewells, some account of, 7013.  
 Distemper in horses, 5765.  
 Distribution of vegetables, 1687.  
 Diuretics used in veterinary medicine, 5903.  
 Dividing lands, 3066; commons, 3067.  
*Dix*, William Spier, his work on agriculture, page 1167. A. D. 1797.  
 Docking, nicking, and cropping in horses, 5877.  
*Dodd*, Ralph, his observations on the dry rot, page 1170. A. D. 1815.  
*Dodson*, Col. William, his work on draining land, page 1163. A. D. 1665.  
 Dog family, *Canis familiaris*, 6635; English sheep-dog, 6637; sheep-dog of Scotland, 6639; mastiff, 6640; bull-dog, 6641; terrier, 6642; pointer, setter, and spaniel, 6643; breeding and rearing of dogs, 6646; diseases, 6647; asthma, 6648; sore eyes, 6650; cancer, 6652; colic, 6653; cough, 6654; distemper, 6655; fits, 6657; inflamed bowels, 6658; inflamed lungs, 6659; madness, 6660; mange, 6665; worms, 6666; worming of whelps, 6667.  
 Dog tic, 6913.  
 Dogs of the Romans, 108.  
*Donaldson*, James, his works on agriculture, page 1167. A. D. 1794.  
*Donaldson*, James, his work on agriculture, page 1163. A. D. 1697.  
*Donald*, R., his work on agriculture, page 1171. A. D. 1822.  
*Donag*, agricultural survey of, 7103.  
*Doria*, Luigi, his work on agriculture, page 1177. A. D. 1798.  
 Dormouse, 6615.  
 Dorsetshire, agricultural survey of, 7033.

- Dosie*, Robert, Esq., his work on agriculture, page 1165. A. D. 1768.
- Double mould-board plough, 2500.-  
Double share plough, 2496.  
Double furrow plough, 2498.
- Douglas*, Robert, D. D., his work on agriculture, page 1168. A. D. 1798.
- Dourches*, Charles, his works on agriculture, page 1174. A. D. 1803.
- Dovecot, 6773; see Pigeon-house.
- Down, agricultural survey of, 7106.
- Dragging, 2893.
- Dragon fly, 6897.
- Draining, history of, 3909; general theory of the causes of wetness in lands, 3910; boggy land, 3929; hilly lands, 3941; mixed soils, 3944; retentive soils, 3949; mines, quarries, and pits, 3955; formation and materials of drains, 3957; implements peculiar to draining, 3965; season, 3980.
- Draining, theory of its effects on soils, 2141.
- Draining ploughs, 2518; Clarke's, 2519; Grey's, 2520; gutter plough, 2521; mole plough, 2522.
- Draining auger, 2431.
- Draining among the Romans, 143.
- Draining on the Trentham estates, 7011.
- Drains, different sorts of, 3961; of conveyance, 3962; of collection, 3963; boxed and rubble drain, 3964; brick drain, 3965; gravel or cinder drain, 3967; wood drain, 3968; spray drain, 3969; straw drain, 3970; turf drain, 3971; triangular sod drain, 3972; hollow furrow drain, 3973; earth or clay pipe drain, 3974; turf pipe drain, 3975; Cheshire turf drain, 3976; mole drain, 3977; wheel drain, 3978; wheel gutter drain, 3979; season for forming drains, 3980; duration, 3982; expense, 3983; enemies of drains, 3984.
- Dralet*, his work on agriculture, page 1174. A. D. 1801.
- Draught machine, 2458; More's, 2459; Braby's, 2460.
- Drill watering machine, 2564.
- Drill culture by Tull, history of, 756.
- Drill culture, history of, in Dumfriesshire, 7053.
- Drill barrow, 2470; turnip barrow drill, 2472.
- Drilling, 3025.
- Drill roller, 2563.
- Drilling turnips, history of, in Northumberland, 7024.
- Drinks and balls, mode of giving, in veterinary surgery, 5863.
- Drinks used in veterinary medicine, 5901.
- Driver*, Abraham and William, their work on agriculture, page 1167. A. D. 1794.
- Driving cattle in a threshing machine, 3063.
- Driving carts and waggons, 3031.
- Dromedary of Arabia, 874.
- Drury*, Charles, his works on agriculture, page A. D. 1810.
- Dry rot, cause of, 3755.
- Dublin, agricultural survey of, 7076.
- Dublin society, establishment of, 801.
- Dubois*, Louis, his work on agriculture, page 1175. A. D. 1824.
- Dubois*, J. B., his work on agriculture, page 1173. A. D. 1790.
- Dubourdien*, Rev. John, his works on agriculture, page 1168. A. D. 1802.
- Duck, *Anas boschus*, 6733; varieties, 6734; Rhone, 6735; Aylesbury, 6736; canvas-backed, 6737; Muscovy, 6738; breeding of ducks, 6739; incubation, 6740; fattening, 6742; decoys for wild ducks, how to form, 6743.
- Ducks of Aylesbury, 6998.
- Ducks, rearing of, in China, 983.
- Ducker's skim coulter plough, 2494.
- Ducouadic*, his work on agriculture, page 1174. A. D. 1800.
- Du Gard*, his observations on killing animals by pithing and slaughtering, 2047.
- Dumfriesshire, agricultural survey of, 7053.
- Diamond, a wedder sheep, 6413.
- Dumont*, Courset, his work on agriculture, page 1173. A. D. 1784.
- Dunbartonshire, agricultural survey of, 7057.
- Duncumb*, John, A. M., his works on agriculture, page 1168. A. D. 1801.
- Dung, 2210; see Manures of animal and vegetable origin.
- Dung yards and pits, 2741.
- Dung drag, 2387.
- Dunrobin House, 7070, fig. 819.
- Dupont*, his works on agriculture, page 1172. A. D. 1764.
- Duration of animals physiologically considered 1954.
- Durham, agricultural survey of, 7023.
- Durion, a fruit of Hindustan, 896.
- Dutch, or short-horned breed of cattle, 6109.
- Dutton*, Hely, Esq., his works on agriculture, page 1169. A. D. 1808.
- Duvergé*, his work on agriculture, page 1172. A. D. 1763.
- Dyeing and thread plants, substitutes for, 5389.
- Dysenteric inflammation, 5801.
- Dysentery in sheep, 6515.
- Dysentery or braxy in horned cattle, 6267.

## E

- Earth borer, 2428; of peat, 2430; draining auger, 2431.
- Earth, estimating the expense of excavating and removing, 3082.
- Earth track, 2388.
- Earth walls, different sorts of, 2845.
- Earths afforded by plants, 1476; lime, 1477; silica, 1478; magnesia, 1479; alumina, 1480; metallic oxides, 1481.
- Earths, as ingredients of vegetable food, 1505.
- Earths and soils considered with reference to culture, 2054; formation of soils, 2055; surface earth, 2059; rocks, how converted into soils, 2061; peaty soils, 2062; classification of soils, 2067; genera, 2068; species, 2069; table of genera, species, and varieties, 2070; discovering the qualities of soils by the plants which grow on them, 2072; by analysis, 2083; mechanically and empirically, 2087; uses of the soil, 2095; improvement of soils, 2112; pulverisation, 2113; compression, 2122; fallowing, 2124; alteration of the constituent parts, 2130; incineration, 2133; by water, 2141; by atmospheric influence, 2150; by rotations of crops, 2154.
- East Lothian, agricultural survey of, 7048.
- East Meath, agricultural survey of, 7084.
- East Riding of Yorkshire, agricultural survey of, 7022.
- Eastern coast of Africa, agriculture of, 114.
- Eboulement, 330; of Mount Grenier, 331.
- Eckhart*, J. Gli., von, his work on agriculture, page 1175. A. D. 1754.
- Economical societies of Spain, 694.
- Economy of live stock and the dairy, 5546.
- Eddoes, Arum and Caladium, various species, 1186.
- Edgeworth*, Richard Lovell, Esq., F. R. S. and M. R. I. A., his essay on roads, page 1170. A. D. 1810.
- Edible tubers, cultivated in China, 976.
- Education, Mr. Farcy's ideas on, 7014.
- Education, Mr. Vancouver's ideas on, 7038.
- Eel, 6812.
- Eels, natural history of, by Headrick, 7064.
- Eggs, preservation of, in Derbyshire, 7014.
- Eggs of insects, different sorts, 6864; to destroy, 6920.
- Egypt, ancient, its agriculture, 8; its embankments, 12; landed property of, 13; soil of, 14; agricultural productions of, 15.
- Egypt, modern, agriculture of, 1045; climate and surface, 1046; fertility, 1047; limits of cultivated Egypt, 1048; landed property, 1049; occupiers, 1050; products, 1051; rice, 1052; wheat, 1053; flax, 1054; hemp, 1055; sugar cane, 1056; fruit trees, 1057; live stock, 1058; buffalo, 1059; horses, 1060; asses, 1061; camel and dromedary, 1062; implements, 1063; operations, 1064; Nubia, 1065.
- Elaboration of the sap of plants, 1524; of carbonic acid, 1530; oxygen, 1531.
- Electricity, its influence on vegetation, 2260; artificial electricity proposed by Darwin and Williams, 2262.
- Elephant of India, 903.
- Elevation, its influence on vegetables, 1699.
- Elkington*, Mr. Joseph, the drainer, some account of, 7012.
- Elliot*, ———, his work on agriculture, page 1179. A. D. 1764.
- Ellis*, William, his works on agriculture, page 1164. A. D. 1732.
- Elstobb*, W., his account of fens, &c., page 1166. A. D. 1793.
- Elymus arenarius, geniculatus and sibiricus (figured), 4205.

- Embanking, 3337; history, 3998; general principles, 4001; pressure of still water, 4002; situation of the bank, 4004; direction, 4005; construction, 4006; materials, 4007; drains and floodgates, 4008.
- Embankments, different kinds of, 4016; earthen wall, 4017; mound, 4018; mound and puddle wall, 4024; mound with reversed slopes, 4025; mound faced with stones, 4026; mound and wicker hedge, 4027; sea wall, 4028; embankments of Holland, 4031.
- Embankments, when first formed in England, 239.
- Embankment in Ceylon, 919.
- Embankments of ancient Egypt, 12.
- Embankments and canals of modern Egypt, 1048.
- Embankment in the Isle of Wight, 7029.
- Embankments of Cambridgeshire, 7001.
- Embankments in Lincolnshire, 7016.
- Embankments in North Wales, 7044.
- Embankments of Flanders, 440; of Snaerskirke, near Ostend, 441.
- Embrocations used in veterinary practice, 5906.
- Emigration to independent America, and other places, comparative view of, 1148.
- Enclosing plantations, 3643.
- Endemical diseases of animals, 1956.
- Engel, Lud. Hm. Hs., von, his work on agriculture, page 1176. A.D. 1803.
- England, agricultural survey of, 6991; Middlesex, 6992. (See the other counties.)
- England, agriculturists of, 6925; laborers, 6926; apprentices, 6927; journeymen, 6928; hedger, 6929; woodman, 6930; head ploughman, 6931; farm bailiff, 6932; bailiff and gardener, 6933; forester, 6934; land steward, 6935; under steward, 6936; demesne steward, 6937; court farmer, 6938.
- England, agriculture in, during the early part of the sixteenth century, 221.
- England, agriculture in, during Queen Elizabeth's time, 223.
- En pisé, or rammed earth walls, 2848.
- Epidemic fever or pest, 5767.
- Epidemical diseases of animals, or epizooties, 1956.
- Epilepsy, 5769.
- Epping butter, 6187.
- Erskine, John Francis, Earl of Marr, his work on agriculture, page 1167. A.D. 1795.
- Eschenbach, Ch. Ghlid., his work on agriculture, page 1176. A.D. 1802.
- Escher, von Berg, his work on agriculture, page 1176. A.D. 1808.
- Essex, agricultural survey of, 6996.
- Estate, management of Sir Joseph Banks's in Lincolnshire, 7016.
- Estimating the value of work and materials, 3083.
- Estimating weight, power, and quantity, 3078.
- Etienne, Charles and J. Liebault, their works on agriculture, page 1171. A.D. 1529.
- European Turkey, agriculture of, 729; climate, 730.
- Evelyn, John, his works on agriculture, page 1163. A.D. 1661.
- Execution of improvements, how to conduct, 4238.
- Exhalation of plants, 1526.
- Exotic vegetables, their introduction into Britain, 1770; in the reign of Edward VI., Mary, Elizabeth, &c., to George III., 1770.
- Extract, what, from what plants obtained, and its application, 1382; extract of catechu, 1383; of senna, 1384; of quinquina, 1385; of saffron, 1386; uses of extracts in medicine, 1387.
- Eyes of horses, diseases of, 5770.
- F.
- Fabbroni, Adamo, his works on agriculture, page 1177. A.D. 1802.
- Fabre, —, his work on agriculture, page 1174. A.D. 1800.
- Faggoting, 2968.
- Fairbairn, John, his work on agriculture, page 1171. A.D. 1823.
- Falconer, William, M.D. F.R.S., his essay on the preservation of the health of persons employed in agriculture, &c., page 1165. A.D. 1789.
- Fallow deer, C. dama, 6619.
- Fallows, working of, 4563.
- Fallowing, theory of, 2124; origin of fallows, 2129.
- Fallowing among the Romans, 123.
- Farcy and glanders, 5823.
- Farcy, John, sen., his work on agriculture, page 1170. A.D. 1811.
- Farish, John, his treatise on flosin grass, page 1170. A.D. 1810.
- Farm cottages, 2718; see cottages.
- Farm offices of Cornwall, 7039.
- Farm servants, management of, in East Lothian, 7048; state of, in Mid Lothian, 7047.
- Farm servants, diet of, in Angushshire, 7064.
- Farm yard dung, management of, 4580.
- Farm servants of Flanders, 533.
- Farm yards; see Farmeries.
- Farm lands, to shelter by plantations, 4223.
- Farm lands, their culture, 4547; general processes, 4548.
- Farm lands, to lay out, 3882; roads, 3883; size of efields, 3885; square fields, 3897; oblong fields, 3898; hedge row trees, 3899; gales, 3901; drainage and water courses, 3902; example from a newly enclosed common, 3903.
- Farm houses in Flanders, 537.
- Farm houses of Tuscany, 284.
- Farm houses of the emigrants to America, 1138, 1146.
- Farm house, octagonal, of the Duke of Bedford, 6999; rectangular, 6999, fig. 774.
- Farm houses of the Marquess of Stafford, in Staffordshire, 7011; of the Anson's there, 7011.
- Farm houses of Middlesex, 6992.
- Farm houses of Norfolk, 7003.
- Farm management, 4508; keeping accounts, 4509; management of servants, 4522; arrangement of labor, 4534; domestic affairs, 4545.
- Farm management of the Romans, 71.
- Farmery of the Earl of Chesterfield, 7014.
- Farmery in the Netherlands, plan of, 432.
- Farmeries of Scotland (figured), 780; of Tuscany, 284.
- Farmeries, their arrangement, 2757; requisites, 2758; for mixed husbandry, 2759; small size, 2760; larger, 2761; a Berwickshire farmery, 2762; for an arable farm on a large scale, 2763, 2764; a Staffordshire farmery, 2765.
- Farmeries, to arrange and lay out, 3851; Sidera Hall, 3855; a Northumberland example, 3857; Fearn, 3858; Knollwall, 3860; Newstead, 3861; Berwickshire example, 3863; Middlesex example, 3866, 3868; anomalous design, 3869; meadow farm, 3870; turnip farm, 3871.
- Farmeries of Cheshire, 7028, fig. 798.
- Farmeries of Mid Lothian, 7047.
- Farmeries of Kincardineshire, 7065.
- Farmeries of Berwickshire, 7049.
- Farmeries of East Lothian, 7048.
- Farmeries of Northumberland, 7024, fig. 797.
- Farmeries of the nomadic agriculturists of Morocco, 1075.
- Farmeries of Mexico, 1160.
- Farmeries of Jamaica, 1179.
- Farmers, personal character and expectations of, 4447.
- Farmers among the Romans, 60.
- Farmers of Tuscany, 285.
- Farmers of Germany, 546.
- Farmers of Flanders, their domestic circumstances, 531.
- Farmers of Mid Lothian, 7047; of Berwickshire, 7049.
- Farmers of North Wales, 7044.
- Farmers, to improve; see Improvement of farmers.
- Farmer's dwelling house, 2712; smaller size, 2714; larger, 2715; second degree, 2716.
- Farmer's society of Dalkeith, 7047.
- Farmery of Ceylon, 918.
- Farming lands of France, 388; corn farming, 389.
- Farming society of Fife, 7062.
- Farming, Scotch, in Oxfordshire, 7004.
- Farming in Ireland, 812.
- Farms, British, different kinds of, 6981; cottage farms, 6981; working mechanics, 6982; village tradesmen, 6983; town and city tradesmen, 6984; of wealthy citizens, 6986; of demesnes, 6987; of professional farmers, 6988.
- Farms, selection, hiring, and stocking of, 4351; circumstances of the farm, 4352; climate, 4353; soil, 4378; subsoil, 4395; elevation, 4399; character of surface, 4404; aspect, 4406; situation in regard to markets, 4408; extent, 4416; tenure, 4421; rent, 4425; taxes and other burdens, 4437; other particulars, 4445; personal character and expectations of the farmer, 4447; capital required, 4454; choice of live stock, 4462.
- Farms and farmeries of the Romans, 72.
- Farriery, its influence on the health of animals, 2057.
- Fattening of calves, 6167.

- Fattening horned cattle, 6174.  
 Fearn, farm of, 3858.  
 Features of plants, as an index to their native country, 1738.  
 February, weather, and agricultural operations to be performed in, page 1190.  
 Feeding animals, principles of, 2024.  
 Feeding cattle, operation of, 2995.  
 Feeding animals for extraordinary purposes, 2038.  
 Feeding tub or trough, 2438.  
 Felis catus, the cat, 6668.  
 Fellenberg, Emmanuel, his establishment at Hofwyl, 343; his works on agriculture, page 1176. A. D. 1808.  
 Felling timber trees, 3752; preparation, 3754.  
 Fen lands of Cambridgeshire, 7001.  
 Fences, hedges, compound sorts, 2803; single hedge and ditch, 2803; hedge and bank, 2804; Devonshire fence, 2806; hedge with posts and rails, 2807; hedge and dead hedge, 2808; hedge and wall fence, 2809; hedge and row of trees, 2811; hedge and belt of planting, 2812; hedge and corners planted, 2813; furze fence, 2814.  
 Fences, hedge kinds, 2780; dead hedges, 2781; live hedges, 2782; choice of hedge plants, 2783; preparation of the soil, 2784; age of the plants, 2785; assorting the plants, 2787; dressing and pruning the plants, 2788; after management of the hedge, 2789; pruning, 2790; management of old hedges, 2794.  
 Fences used in agriculture, 2767; situation, 2768; kinds, 2771.  
 Fences, walls, 2831; dry stone, 2832; land stones, 2833; quarried stones, 2834; galloway dike, 2835; stone and lime, 2836; stone and clay, 2837; stone and clay dashed with lime, 2838; dry stones lipped with lime, 2839; dry stones lipped and harled, 2840; dry stones pinned and harled, 2841; dry stone and paling, 2842; bricks, 2843; frame walls, 2844; turf walls, 2845; stone and turf walls, 2846; mud and straw, 2847; rammed earth or *en pisé*, 2848; stamped earth, 2849.  
 Fences, ditch or drain kinds, 2772; open ditch, 2774; simple ditch, 2775; double ditch, 2776; bank of earth, 2777; ha-ha, or sunk fence, 2778; double ditch and hedge, 2779.  
 Fences, palings, 2815; nailed paling, 2816; horizontal paling, 2817; upright lath paling, 2818; horizontal paling, 2819; chain fence, 2820; rope fence, 2821; hurdles, 2822; wattled fence, 2824; paling of growing trees, 2825; shingle fence, 2826; worked fence, 2827; park paling, 2830.  
 Fences for plantations, 3643.  
 Fences of Sweden, 670.  
 Fencing among the Romans, 144.  
 Fermanagh, agricultural survey of, 7100.  
 Fermenting of manures, theory of its effects, 2205.  
 Ferrario, G. A., his works on agriculture, page 1173. A. D. 1818.  
 Ferret, 6671.  
 Festuca fluitans, manna grass, its culture in Russia, 656.  
 Festuca fluitans, its culture as a grain, 4733.  
 Fetlock, strains of, 5835.  
 Fever in sheep, 6503.  
 Fever in horned cattle, 6245 and 6254.  
 Fever medicines used in veterinary practice, 5909.  
 Fibrina, obtained from the papaw tree, 1381.  
 Field beet, culture of, 4962.  
 Field gate of Holland, 421.  
 Fields, shape and size of, to improve, 4218, 4221.  
 Fifeshire cattle, 6124.  
 Fifeshire, agricultural survey of, 7062.  
 Fig, its culture in France, 411.  
 Figs, culture of, in the Morea, 732; caprification, 732.  
 Filtration of water, 4158.  
 Findlater, Rev. Charles, his work on agriculture, page 1168. A. D. 1802.  
 Finland, agriculture of, 668.  
 Finlayson's rid plough, 2504.  
 Finorchi, Anton Maria, his work on agriculture, page 1816. A. D. 1816.  
 Fiorin hay, to make, 5229.  
 Firing, in veterinary surgery, 5873.  
 Fischer, H. L., his work on agriculture, page 1176. A. D. 1797.  
 Fischer, C. F. J., his work on agriculture, page 1176. A. D. 1785.  
 Fish, subjected to cultivation, 6798; carp, 6801; tench, 6803; gudgeon, 6805; perch, 6806; pike, 6808; gold fish, 6809; minnow, 6810; trout and salmon family, 6811; eel, 6812.  
 Fish, castration of, 6815.  
 Fish, culture of, in Berkshire, 7005.  
 Fish ponds, construction of, 6799.  
 Fish ponds of France, 397.  
 Fisheries, their establishment on estates, 3594; marine, 3595; river and lake fisheries, 3595.  
 Fisheries, kinds of, 3595; herring, 3596; cod or white fishery, 3597; turbot, 3598; mackerel, 3599; soles, dorics, mullet, &c., 3600; stickleback, 3601; pilchards, 3602; lobsters, crabs, &c., 3603; oyster, 3604; salmon, 3605; trout, 3623; crawfish, 3625; leech, 3626.  
 Fisheries of Sutherland, 7070.  
 Fishery, art of, in China, 986.  
 Fistulous withers, 5780.  
 Fitzherbert, Sir Anthony, his works on agriculture, page 1162. A. D. 1532.  
 Flail, 2399.  
 Flax, its culture and management, 5292; pulling, 5304; rippling, 5308; watering, 5311; breaking without watering, 5320; flax seed jelly, 5325.  
 Flax, its culture in Egypt, 1054.  
 Flax, culture of, in Flanders, 472.  
 Flax, Pulex, 6912.  
 Fleming, or Fleming, Malcolm, M. D., his works on agriculture, page 1179. A. D. 1754.  
 Flexible tube, 2442.  
 Flies, dragon, 6897; day fly, 6908; spring fly, 6899; gall fly, 6901; saw fly, 6902; gad fly, 6906; crane fly, 6907; flesh fly, 6908; Hessian fly, 6908, and 6862; cheese fly, 6908; gnat fly, 6909; spider fly, 6910; forest fly, 6910.  
 Flints, 3389.  
 Floating land, 4110.  
 Floating islands in Mexico, 1154; in New England, 1155.  
 Floods, injuries by, to guard against, 4038.  
 Flowing meadows, 4094.  
 Floyd, Edward, his works on agriculture, page 1163. A. D. 1804.  
 Fluke worms in sheep, 6528.  
 Flux, slimy, — see Dysentery.  
 Fly, common, 6908.  
 Foals and mares, treatment of, 5976.  
 Fogs, their influence on the earth, 2250.  
 Folds for cattle of the Hottentots, 1110.  
 Fomentations in veterinary surgery, 5865.  
 Fontalard, Jean Francois de, his work on agriculture, page 1174. A. D. 1794.  
 Food of plants, 1495; water, 1496; gasses, 1497; extent, 1502; salts, 1504; earths, 1505; carbon, 1510.  
 Food of horses, 6015.  
 Foot, Peter, his work on agriculture, page 1167. A. D. 1794.  
 Foot of the horse, physiology of, 5747.  
 Foot rot in sheep, 6523.  
 Foot stoppings for horses, 5918.  
 Founder, or chronic founder, in the feet, 5850.  
 Forbes, Francis, Gent., his works on agriculture, page 1165. A. D. 1778.  
 Fordyce, George, M. D. F. R. S., his work on agriculture, page 1164. A. D. 1765.  
 Forests of Sweden, 684.  
 Forests and woodlands of Flanders, 519.  
 Forests of Poland, 636.  
 Forests of Russia, 661.  
 Forests of Austria, 626.  
 Forests, culture of, in Germany, 555.  
 Forests of the Morea, produce of, 735.  
 Forests, culture of, in Spain, 726.  
 Forests of Persia, 864.  
 Forests of Mexico, 1162.  
 Forests of China, 1003.  
 Forest culture of France, 401.  
 Forking, 2892.  
 Forks, 2379.  
 Forsyth, Robert, Esq., his work on agriculture, page 1169. A. D. 1804.  
 Foul in the foot, in cattle, 6272.  
 Foulahs of Africa, agriculture of, 1078.  
 Fowls, aserine or aquatic, 6732; duck, 6733; goose, 6746; swan, 6752; bustard, 6756; gallinaceous, 6880; diseases of, 6757.  
 Fowls, mode of feeding, so as to enlarge their livers, 2041.  
 Fowls, mode of fattening for the London market, 2040.  
 Fox, 6848; to shoot, 6849; to take with a hook, &c. 6850.  
 Fox, John, his works on agriculture, page 1167. A. D. 1794.  
 Fox, William, his work on agriculture, page 1167. A. D. 1796.

- France, agriculture of, from the fifth to the seventeenth century, 185.
- France, present state of agriculture in, 373; progress from the time of Louis XIV. to the present time, 374; state during the revolution, 376; surface, 376; soil, 380; climate, 381; landed property, 387; farming lands, 388; corn farming, 389; meadows, 390; sheep, 391; beasts, 392; dairies, 394; poultry, 395; swine, 396; fish ponds, 397; implements and operations, 398; plants cultivated, 400; forests, 401; vine, 407; mulberry and silk worm, 408; olive and other fruits, 410.
- Frances, Aimé, his work on agriculture, page 1175. A.D. 1822.
- Francois, Nicolas, his works on agriculture, page 1172. A.D. 1763.
- Fraser, Robert, Esq., his works on agriculture, page 1166. A.D. 1793.
- Free-martin, a term signifying a barren heifer, that has been a twin with a bull-calf.
- French's turnip drill, 2556.
- Fret, colic, gripes, or gullion, 5805.
- Friendly islands, agriculture of, 1039.
- Frog, esculent, 6317.
- Frog hopper, 6883.
- Frog, tree, or singing frog, 6818.
- Fromage-de-Feugre, C. Michel F., his work on agriculture, page 1174. A.D. 1802.
- Frontal worms in sheep, 6527.
- Frost, theory of, 2306.
- Frost shoes for horses, 5936.
- Fruit trees in orchards, 3776.
- Fruit trees in Switzerland, 338.
- Fruits among the Romans, 146.
- Fuci, or sea-weeds, their culture and manufacture, 5529.
- Fucus lichenoides, and other sea-weeds eaten in Cochinchina and China, 944.
- Fucus saccharinus (figured), 1307; palmatus (figured), cūlis (figured), 1307.
- Fullarton, Col., his work on agriculture, page 1166. A.D. 1793.
- Fuller's thistle, its culture, 5339.
- Fumigations used in veterinary practice, 5913.
- Fungi, or mushroom tribe, their utility, 1310.
- Furrow roller, 2583.
- Furze or whin, culture of, 5076.
- G.
- Gacon Dufour, Marie-Armande-Jeanne, his work on agriculture, page 1174. A.D. 1807.
- Gad fly, 6906.
- Gagliardo, G. B., his work on agriculture, page 1178. A.D. 1813.
- Gaiting, operation of, 2940.
- Galeotti, Francesco, his work on agriculture, page 1177. A.D. 1807.
- Gall in sheep, 6515.
- Gall fly, 6901.
- Gallinaceous poultry, 6680.
- Gallizioli, Filippo, his work on agriculture, page 1178. A.D. 1815.
- Gallo, Agostino, his works on agriculture, page 1177. A.D. 1564.
- Galloway dyke, 2835.
- Galway cattle, 7054.
- Galway, agricultural survey of, 7095.
- Gamboge gum, in Cambodia, 943.
- Garden farms of Essex, plan of, 6996.
- Gardens of laborers' cottages, 2756.
- Gardens and orchards of Middlesex, 6992.
- Gardens of mechanics in Lancashire, 7027.
- Gases as ingredients of vegetable food, 1497.
- Gates appropriate to agriculture, 2850; principles of construction, 2851; timber gates, 2856; iron gates, 2857; pillars of gates, 2858; fastenings, 2860; swing gates, 2864; tressel bar gate, 2866; slip bar gate, 2867; chained slip bar gate, 2868; wicket gate, 2869; styles, 2870; style of falling bars, 2871; folding gate, 2873; Clarke's sash gate, 2874.
- Gathering, operation of, 2900.
- Gautier, Giuseppe, his work on agriculture, page 1177. A.D. 1807.
- Gavellus, Nicholas, his work on agriculture, page 1177. A.D. 1758.
- Geese, how to feed, so as to enlarge their livers, 2041.
- Gemiparous animals, 1949.
- Geographical position, its influence on vegetables, 1688.
- Geographical distribution of animals, 1962.
- Geology considered with reference to agriculture, 2055.
- Germany, present state of agriculture in, 543; general view, 544; Denmark, Greenland, and Iceland, 558; Prussia, 563; Hanover, 581; Saxony, 596; Bavaria, 603; Austria, 607.
- Germany, agriculture of, from the fifth to the seventeenth century, 192.
- Germination of the seeds of plants, 1486; physical phenomena, 1493; chemical phenomena, 1494.
- Ghee, an article of diet in Hindustan, made from the milk of the buffalo, 898.
- Giacinto, P. Carlo, his work on agriculture, page 1178. A.D. 1811.
- Gialdi, Giuseppe, his work on agriculture, page 1178. A.D. 1813.
- Gid in sheep, 6524.
- Gilbert, Francois-Hilaire, his works on agriculture, page 1174. A.D. 1797.
- Girdling trees, 1642.
- Girton, Daniel, his treatise on pigeons, page 1166. A.D. 1779.
- Glaciers, or ice hills, 334.
- Glanderous rot in sheep, 6508.
- Glanders and farcy, 5823.
- Glossology, or the study of the names of the parts of plants, 1266.
- Gloucestershire waggon, 2621.
- Gloucestershire, agricultural survey of, 7006.
- Gluten, how obtained, manufactured, and applied, 1378; its great importance in forming bread, 1379.
- Gnat, 6909.
- Goat, 6582; Angora goat, 6583; Syrian, 6584; chamois, 6585; goats of Wales, 6586.
- Goat, chamois, in Switzerland, 341.
- Goat of Hindustan, 901.
- Goggles in sheep, 6524.
- Gold fish, 6809.
- Gold fish of China, 986.
- Gooch, Rev. W., his work on agriculture, page 1170. A.D. 1811.
- Gooseberry caterpillar, to destroy, 6920.
- Goose, Anas anser, 6746; varieties and species, 6747; Spanish, Embden, Chinese, Canadian, 6748; breeding, 6749; rearing, 6750; feathers, 6751; swan, 6752; Muscovy goose, 6752.
- Gossypium herbaceum (figured), cotton plant, its culture in Italy, 318.
- Gotthard, J. Ch., his work on agriculture, page 1176. A.D. 1802.
- Grafting and budding, 1621.
- Granadilla passiflora (figured), 1165.
- Granary, 2699; commercial, 2702; perpetual, 2703.
- Grass seed harrow, 2572.
- Grass shoes for horses, 5935.
- Grass lands, their management, 5196; meadows, 5197; for irrigation, 5199; uplands, 5200.
- Grass lands, their conversion to arable, 5261; rotation of crops, 5279.
- Grasses, their culture, 5086; tall growing or hay grasses, 5092; hay grasses of temporary duration, 5093; hay grasses of permanent duration, 5105; pasturage grasses, 5124; grasses experimented on at Woburn, 5146; best grasses for straw plait, 5193.
- Grasses, forage and pasture, enumeration, properties, and culture, 5086. 5195; for the purposes of plait, 5193.
- Grasshopper, 6882.
- Gravel, 3391.
- Gravel and stone in horses, 5817.
- Gray's seed harrow for wet weather, 2574.
- Gray, Andrew, his work on agriculture, page 1169. A.D. 1808.
- Grease and cracks in horses, 5845.
- Greaves, William, his work on agriculture, page 1169. A.D. 1804.
- Greece, modern agriculture of; see Thessaly, 736.
- Greg, Thomas, Esq., his work on agriculture, page 1169. A.D. 1809.
- Greek, ancient, their agricultural implements, 24.
- Greeks, ancient, their agricultural products, 27.
- Greeks, ancient, their agriculture, 17.
- Greeks, ancient, landed property among, 21.
- Greenland, agriculture of, 562.
- Greenway, Dr. James, his work on agriculture, page 1179.
- Grey's draining plough, 2520.
- Griesenthal, William, his work on agriculture, page 1170. A.D. 1820.
- Gripes, colic, fret or gullion, 5805.

Grooming of horses, 6039.  
 Ground nut, *Arachis hypogaea* of China, 976.  
 Growth or development of vegetables, physiology of, 1537.  
 Grubbers, 2527.  
 Grubbing mattocks of Devonshire, 7038.  
 Guava of the Mauritius (figured), *Psidium pyriferum*, 1116.  
 Gudgeon, 6805.  
 Guernsey and Alderney cattle, 7040.  
 Guernsey, agricultural survey of, 7042.  
 Guillaume, Ch., his work on agriculture, page 1175. A. D. 1821.  
 Guillot, Julien Jean Jacques, his work on agriculture, page 1172. A. D. 1761.  
 Guinea grass, *Panicum polygonum* (figured), 1186.  
 Guinea hen, Numidia, 6730.  
 Guinea pig, 6614.  
 Gullion, colic, gripes or fret, 5805.  
 Gum, what and how obtained, 1369; uses, 1371.  
 Gum arabic tree, *Mimosa nilotica* (figured) 1079.  
 Gum resins, from what plants obtained, and how manufactured and used, 1446; galbanum, 1447; ammoniac, 1448; scammony, 1449; opoponax, 1450; euphorbium, 1451; olibanum, 1452; sagapenum, 1453; gamboge, 1454; myrrh, 1455; assafetida, 1456.  
 Gutta serena, 5771.  
 Gutter in irrigation, 4085.  
 Gutter draining plough, 2521.  
 Gypsum, theory of its operation on soils, 2229; introduced to America by Franklin, 2230.

## H.

Ha ha, or sunk fence, 2778.  
 Hail, theory of, 2308.  
 Hainault scythe, mode of mowing with, 2936.  
 Hainault scythe in use in Flanders, 502.  
 Hair, its nature and properties, 1814.  
 Hamel, Du Monceau, Henry Lewis du, his works on agriculture, page 1171. A. D. 1750.  
 Hampshire wheel plough, 2513.  
 Hampshire, agricultural survey of, 7029.  
 Hand barrow, 2451.  
 Hand drill machines, 2468; for beans, 2469; turnips, 2470.  
 Hand hoeing, 2894; between rows, 2895.  
 Hand raking, 2896.  
 Hand turnip roller, 2473.  
 Hand threshing machine, 2453.  
 Hanover, agriculture of, 581; agricultural society founded by Geo. II., 582; landed property, 583; occupiers, 585; sheep, 589; bayers, farming of, 594.  
 Hard labor, how to feed and prepare an animal for, 2045.  
 Hare warren, near Banstead Downs in Surrey, 6613.  
 Hare, 6612.  
 Harnessing cattle, 2996.  
 Harrison, Gustavus, Esq., his work on agriculture, page 1165. A. D. 1775.  
 Harrowing, growing corn among the Romans, 140.  
 Harrowing, 3020.  
 Harrows, 2568; common, 2569; angular, 2570; rhomboidal, 2571; grass seed, 2572; brake or levelling barrow, 2573; Gray's seed harrow, 2574; bush harrow, 2576.  
 Harrows, circular, 7002.  
 Harrows, improved form of, 7014.  
 Hartig, Fr. Grafen von, his work on agriculture, page 1176. A. D. 1786.  
 Hartiz, Georges Louis, his work on agriculture, page 1176. A. D. 1790.  
 Hartlib, Samuel, his works on agriculture, page 1163. A. D. 1645.  
 Hasfer, F. W., his work on agriculture, page 1171. A. D. 1756.  
 Hatches in irrigation, 4079.  
 Hatted kit, a preparation of milk, 6376.  
 Hawks, and hawking, 6797.  
 Hay, to truss, 2950.  
 Hay knife, 2408.  
 Hay swoop, 2598.  
 Hay stands, 2749.  
 Hay tedding machine, 2597; 5225.  
 Hay tea, to make, 5234.  
 Hay stacks, their formation, 5226; salting, 5233.  
 Hay from bog meadows, 5229; from fiorin meadows, 5229.  
 Hay-making among the Romans, 138.  
 Hayes, Samuel, his work on woods, &c., page 1167. A. D. 1795.  
 Hayward's cultivator, 2537.  
 Heading down trees, 3699.  
 Head main in irrigation, 4080.  
 Headrick, James, his works on agriculture, page 1169. A. D. 1807.  
 Heat, its agency in vegetable culture, 2246.  
 Heat, its influence on the distribution of animals, 1963.  
 Hedge bills, 2413; Blackie's bills, 2415.  
 Hedge fences, compound sorts, 2803; see Fences.  
 Hedge shears, 2410.  
 Hedge fences, 2780; young, 2781; old hedges, 2794.  
 Hedges of Durham, 7023; of Northumberland, 7024.  
 Hedges, old, to manage, 2794; cutting down, 2795; filling up gaps, 2800; mending defects, 2801.  
 Hedging and ditching, 2967.  
 Hegemon, Philibert, his work on agriculture, page 1171. A. D. 1583.  
 Helix pomatia (figured), snail cultivated in Hungary, 624.  
 Hemipterous insects, 6877.  
 Hemp, its culture and management, 5327; sowing, 5330; pulling, 5332; watering, 5334.  
 Hemp, its culture in Egypt, 1055.  
 Hempseed oil, its uses, 1418.  
 Henderson, J., his work on agriculture, page 1170. A. D. 1812.  
 Henderson, Robert, his work on agriculture, page 1170. A. D. 1811.  
 Hepatitis, or yellows, 5810.  
 Herbage plants, culture of, 4982; nutritive products of, 4984.  
 Herding, or tending cattle, 2993.  
 Herefordshire and Sussex cattle, 6114.  
 Herefordshire, agricultural survey of, 7009.  
 Heresbachius, Conradus, his work on agriculture, page 1175. A. D. 1578.  
 Hermbstadt, Sgm. F., his work on agriculture, page 1176. A. D. 1803.  
 Hertfordshire and Kentish wheel ploughs, 2514.  
 Hertfordshire, agricultural survey of, 6297.  
 Hesiod, his poem on rural affairs, 18.  
 Hessian-fly, 6862.  
 Hesson, Jacques, his work on agriculture, page 1171. A. D. 1569.  
 Hide-bound in horses, 5822.  
 Higgins, Jesse, his work on agriculture, page 1179.  
 Highland cattle, 6118.  
 Hill farm, to shelter, 4237.  
 Hillenbrand, Aut, his work on agriculture, page 1176. A. D. 1784.  
 Hindustan, agriculture of, 877; climate and surface, 878; soil, 879; landed property, 880; agricultural products, 881; sugar cane, 882; indigo, 883; silkworm, 884; poppy, 885; tobacco, 886; oil plants, 887; palm trees, 888; dates, 894; bamboo, 895; sheep, 896; pastures, 897; live stock, 898; ox, 899; fruits, 900; goat, 901; swine, 902; elephant, 903; camel, 904; predatory animals, 905; implements and operations, 906; cart, 907; irrigation, 908; harvesting, 912.  
 Hinny, 6098; see Mule and hinny.  
 History of agriculture during the middle ages, 179.  
 History of agriculture, 1; see Agriculture, and the different names of countries.  
 Hitt, Thomas, his work on agriculture, page 1164. A. D. 1760.  
 Hodskinson, Joseph, his work on agriculture, page 1167. A. D. 1794.  
 Hoe scythe or thistle hoe, 2549.  
 Hoeing turnips, history of, in Northumberland, 7024.  
 Hoeing, by hand, 2894.  
 Hoes, hand, 2389.  
 Hoes, horse, 2539; see Horse hoe.  
 Haffmann, A., his work on agriculture, page 1176. A. D. 1809.  
 Hafsmann, Gli. Bd. Freyherr von, his work on agriculture, page 1176. A. D. 1784.  
 Hofwyl, agricultural establishment of, near Berne, 343.  
 Hog, 6530; see Swine.  
 Hog, a wedder lamb after being weaned, 6413; shear hog, a hog of two years, 6413.  
 Hog styes, 2680.  
 Hogg, James, his work on agriculture, page 1169. A. D. 1807.  
 Hoggit, or hog sheep; see Hog.

- Home*, Henry, usually called Lord Kames, 786; his works on agriculture, page 1165. A. D. 1776.
- Home*, Francis, M.D., his work on agriculture, page 1164. A. D. 1757.
- Home*, Sir Everard, his observations on killing animals by pithing, 2049.
- Homery*, Henry, his works on agriculture, page 1164. A. D. 1766.
- Homestals; see *Farmeries*.
- Holcus sorghum (figured), or Indian millet, its culture, 4727.
- Holland*, Henry, Esq. M.D., his work on agriculture, page 1169. A. D. 1807.
- Holland, present state of agriculture in, 418; climate, 418; landed property, 419; pasturage and dairy management, 420; implements and operations, 421.
- Holt*, John, his works on agriculture, page 1167. A. D. 1795.
- Honey dew, a disease of plants, 1660.
- Hoob*, Thomas Sutton, Esq., his work on gypsum, page 1169. A. D. 1805.
- Hoofs of animals, their nature and properties, 1826.
- Hoof liquid of veterinary practice, 5914.
- Hop, culture of in Flanders, 477.
- Hop, its culture and management, 5393; soil, 5396; planting, 5401; after-culture, 5408; manuring, 5411; earthing, 5412; dressing, 5413; poles, 5417; taking the crop, 5425; drying, 5429; bagging, 5431; usual produce, 5435; diseases, 5440; duty on hops, 5448.
- Hope*, of Rankellor, a great improver, 778.
- Hornby*, Thomas, Esq., his dissertation on lime, page 1170. A. D. 1815.
- Horne*, or *Horn*, John, his work on agriculture, page 1166. A. D. 1786.
- Horned cattle, 6104; working of, 6125; diseases of, 6244; fattening of, 6174; breeding of, 6144; rearing of, 6152; anatomy and physiology of, 6227.
- Hornless or polled breed of cattle, 6115.
- Hornor*, T., Esq., his method of delineating estates, page 1170. A. D. 1813.
- Horns of animals, their nature and properties, 1822.
- Horse family, character and history of, 5548; horse, varieties of, 5550; Arabians, 5550; Spanish horses, 5552; French horses, 5553; Flemish, 5554; Dutch, 5555; German, 5556; Polish, 5557; Russian, 5558; Swedish, 5559; British, 5560.
- Horse, British varieties of, 5560; race horse, 5561; hunter, 5563; hackney, 5564; old English road-horse, 5565; Irish road-horse, 5567; Cobs, Galloways, and ponies, 5568; British draught horses, 5570; black horse, 5571; Cleveland bay, 5572; Suffolk punch, 5573; Clydesdale horse, 5574; Welch horse, 5575; Galloway, 5576; small horse of the highlands, 5577.
- Horse, organology, or exterior anatomy of, 5578; organs of the head, 5580; trunk, 5596; fore-extremities, 5608; hinder extremities, 5622; color of horse, 5625.
- Horse, anatomy, or osseous structure of, 5630; anatomy of the head, 5631; of the trunk, 5637; of the extremities, 5644.
- Horse, physiology, or functions of, 5660; general functions, 5661; blood vessels, 5671; absorbents, 5680; nerves and glands, 5681; integuments, 5685; the head, 5692; the ear, 5694; the eye, 5697; the nose, 5700; the mouth, 5708; the neck, 5716; the chest, 5718; the abdomen, 5725; the organs of generation, 5739; the feet, 5747.
- Horse, diseases of, 5753; in and out of condition, 5754; inflammatory diseases, 5757; diseases of the head, 5769; diseases of the neck, 5780; of the chest, 5783; of the skin, 5818; glanders and farcy, 5823; diseases of the extremities, 5828; diseases of the feet, 5848.
- Horse, veterinary operations on, 5861; treatment of wounds, 5862; balls and drinks, 5863; fomentations and poultices, 5865; setons and rowels, 5868; blistering and firing, 5870; clystering and physicking, 5874; castration, nicking and docking, 5877; bleeding, 5878; pharmacopœia, 5879.
- Horse patters, 5939.
- Horse breeding and management of, in Yorkshire, 7021.
- Horse hoeing husbandry, origin and history of, 756.
- Horse hoeing, 3023; turnips, 3024.
- Horse hoes, 2539; Scotch, 2540; Northumberland, 2541; Wilkie's, 2542; Blaikie's, 2544; Morton's, 2545; Amos's, 2547; castor wheel hoe, 2548; thistle hoe, 2549.
- Horse stubble rake, 2594.
- Horse raking, 3030.
- Horse fly, 6910.
- Horseanship, art of, 6002.
- Horses, shoeing of, 5925.
- Horses, criteria of good qualities, 5940; breeding of, 5960; rearing, 5975; training of, 5984; art of horseanship, 6002; feeding, 6015; stabling and grooming, 943.
- Horses, management and working, 6045; of the hunter, 6056; of the race horse, 6046; of riding horses, 6063; of horses in carriages and coaches, 6072; of cart, waggon, and farm horses, 6074.
- Horses, as laboring animals, 4468.
- Horses of Hungary, 621.
- Horses of Arabia, history of, 875.
- Horses, Cleveland bays (figured), 780.
- Horses of the Romans, 107.
- Horses of the Cape of Good Hope, 1104.
- Horses of Egypt, 1060.
- Hot yellows in sheep, 6518.
- Hottentots' bread, Elephantopus (figured), 1111.
- Hove, blast, or wind colic in sheep, 6511.
- Hove, or blown in cattle, 6253.
- Houghton*, John, F.R.S., his works on agriculture, page 1163. A. D. 1681.
- House cricket, 6881.
- Housing roots, 3049.
- Howard*, Hon. Charles, his work on agriculture, page 1163. A. D. 1678.
- Hoyle*, Henry, his work on agriculture, page 1168. A. D. 1801.
- Huber*, Francis, his work on agriculture, page 1176. A. D. 1796.
- Huber*, P., his works on agriculture, page 1176. A. D. 1801.
- Huish*, Robert, Esq., his treatise on bees, page 1170. A. D. 1815.
- Hungarian horses, 621; grand huras, or breeding stud, 621.
- Hungarian sheep, 621.
- Hunger, 1930.
- Hunger rot in sheep, 6521.
- Hunt*, Charles Henry, Esq., his treatise on sheep, page 1170. A. D. 1810.
- Hunter*, Alexander, M.D., F.R. SS. L. and E., his works on agriculture, page 1165. A. D. 1770.
- Hunting shoe for horses, 5933.
- Huntingdonshire, agricultural survey of, 7000.
- Hurdles, 2822.
- Hutches, or boxes for rabbits, 6602.
- Huts of the improved Hottentots, 1109.
- Huts of the native Hottentots, 1108, 1109.
- Huzard*, Jean Baptiste, his works on agriculture, page 1174. A. D. 1794.
- Hybernation of animals, 1974.
- Hybrid productions in vegetables, how formed, 1598; supposed limits, 1601; anomalous effects, 1602.
- Hybridous animals physiologically considered, 1950.
- Hydatids, or staggers in sheep, 6524.

## I.

- Ice, theory of, 2311.
- Iceland, agriculture of, 562.
- Ichneumon insect, 6903.
- Implements for irrigation, 4062; line, reel, and breast plough, 4063; spades, 4064; crescent, 4065; turf knife, 4066; wheelbarrows, 4067; handbarrows, 4068; scythes, 4070; forks and hacks, 4071; water proof boots, 4072.
- Implements and operations of French agriculture, 398.
- Implements of the ancient Greeks, 24.
- Implements of agriculture, their invention in Egypt, 10.
- Implements of British agriculture, 2373.
- Implements and machines of Cornwall, 7039.
- Implements peculiar to draining, 3985; scoop, 3986; shovel, 3987; sod knife, 3988; draining spades, 3989; borers, 3991; auger, 3992; horizontal auger, 3993.
- Improved quarry cart, 2617.
- Improvement of farmers, 4243; by books, 4244; by schools for their children, 4245; by examples of good culture, 4246; by personal attention, 4248; by conversation, 4249; by encouraging leading men, 4250; by an experimental farm, 4251.
- Improvement of lands in culture, 4207; see *Cultivated lands*.
- Improvement of estates already more or less improved, see *Cultivated lands*.
- Improvement of waste lands, 4159; see *Waste lands*.

- Improvements, general cautions in making, 4254.  
 Improvements, execution of, 4238.  
 Improvements, general obstacles to, in the highlands, 7071.  
 Improvements in Sutherland, 7070.  
 Improvements, public, of Ayrshire, 7055.  
 Improvements in Berwickshire, history of, 7049.  
 Improvements of General Dirom in Dumfriesshire, 7053.  
 Improving leases the foundation of Scottish agricultural improvement, 744.  
 Incontinence of urine, 5815.  
 Independent Tartary, its agriculture, 865; climate, 866; surface, 867; soil, 868; tillage, 869.  
 Indian corn, or maize, its culture, 4734.  
 Indian millet, *Holcus sorghum* (figured), its culture, 4727.  
 Indigo, culture of, in the West Indies, 1189.  
 Indigo, *Indigofera tinctoria* (figured), its culture and application in Hindustan, 883.  
 Indigo and sugar, attempt to cultivate, in Italy, 58.  
 Infanda tree, its uses in Congo, 1084.  
 Inflamed liver in sheep, 6513.  
 Inflammation of the kidneys, or red water in cattle, 6262.  
 Inflammation of the liver in horses, 5810.  
 Inflammation of the bladder in cattle, 6264.  
 Inflammation, of the brain in horses, or phrenitis, 5760.  
 Inflammation of the bowels, 5795.  
 Inflammation of the lungs, 5783.  
 Inflammation of the stomach in cattle, 6256. 6260.  
 Inflammation of the lungs in cattle, 6255.  
 Inflammation of the liver, or hot yellows in cattle, 6261.  
 Inflammatory fever in horse diseases, 5785; general, 5785; local, 5789.  
 Influenza, or catarrhal fever in horses, 5765.  
 Influenza, or catarrh, 6248.  
 Insects subjected to cultivation, 6321; silkworm, or moth, 6822; honey bee, 6827; craw or crayfish.  
 Insects injurious to agriculture, 6862; physiology of insects, 6863; coleoptera, 6871; hemiptera, 6877; neuroptera, 6896; hymenoptera, 6900; diptera, 6905; aptera, 6911; operations for destroying, 6916.  
 Insects, to subdue, 6916; preventive operations, 6917; palliative, 6918; destructive, 6919.  
 Interitis, or red colic, 5797.  
 Inverness-shire, agricultural survey of, 7071.  
 Ipæacuanha root, *Cephaelis ipæacuanha*, 1209.  
 Ireland, agricultural survey of, 7074.  
 Ireland, agricultural circumstances of, 7075.  
 Ireland, agriculture of, 795; in the reign of James I., 797; under Cromwell, 800; Dublin society, 801; climate, 804; territorial surface, 805; soil, 806; bogs, 807; landed property, 809; leases, 811; farming, 812; rent, 813; implements and operations, 824; dairy, 829; poor, 831; middlemen, 834; tithes, 836; fertility of the country, 844.  
 Irish cattle, 6129.  
 Irrigation in Hindustan, 908.  
 Irrigation, 4053; history, 4054; soils and situations suitable, 4056; advantages, 4061; implements, 4062; terms made use of, 4074; preparation of surfaces, 4096; warping, 4117.  
 Irrigation among the Romans, 141.  
 Irrigation in Lombardy, 267.  
 Irrigation in Mexico, 1157.  
 Irrigation, theory of its effects on soils and plants, 2145; surface irrigation, 2146; subterraneous irrigation, 2147; warping, 2148.  
 Irrigation, subterraneous, 4124.  
 Irrigation, practice of, at Trentham, 7011.  
 Irrigation first introduced in Cambridgeshire, 7001.  
 Irrigation and draining, Jessop's ideas on, 7011.  
 Irrigation, Parkinson's opinion of, 7017; Loch's opinion of, 7011.  
 Isle of Bourbon, 1117.  
 Isle of France, or Mauritius, agriculture of, 1116.  
 Italy, present state of agriculture in, 260; in Lombardy, 262; in Tuscany, 276; in the Maremmes, 298; in the Neapolitan territory, 312.  
 Italy, agriculture of, during the middle ages, 180.  
 Italy, agricultural circumstances of, during the time of the Romans, 63.  
 Itch mite, 6913.
- J.
- Jackall of India (figured), 905.  
 Jacquin, M. E., his work on agriculture, page 1174. A. D. 1804.
- Jamaica, agriculture of, 1174; landed property, 1175; overseers of estates, 1176; head driver, 1177; laborers, 1178; buildings, 1179; overseers' house, 1180; lime kiln, 1181; houses of the slaves, 1182; live stock, 1184; agricultural operations, 1185; productions, 1186; fruits, 1186; sugar cane, 1187; cotton plant, 1188; indigo, 1189; coffee tree, 1190; cocoa root, 1192; plantain, 1193; Indian arrow root, 1194; other plants, 1195; Guinea grass and Scotch grass, 1198; vermin, 1199.  
 January, weather and agricultural operations to be performed in, page 1189.  
 Japan, agriculture of, 946.  
*Jatropha manihot*, cultivated in Sierra Leone, 1079.  
 Jaundice in sheep, 6514.  
 Java, agriculture of, 927.  
 Jelly of flax seed, 5325.  
 Jersey, Guernsey, Alderney and Sark, agricultural surveys of the islands of, 7040; Jersey, 7041; Guernsey, 7042.  
 Jerusalem artichoke, field culture of, 4980.  
 Jewish modes of killing animals, 2050.  
 Jewish vineyard, 33.  
 Jews, their agriculture, 29.  
 Jews, landed property among, 31.  
 Jews, their agricultural produce, 35.  
 Johnson, Cuthbert William, his work on agriculture, page 1170. A. D. 1820.  
 Johnson, John, his work on agriculture, page 1170. A. D. 1814.  
 Johnstone, John, Esq. his work on draining land, page 1167. A. D. 1797.  
 Juices of plants, physiologically considered, 1470.  
 July, weather and agricultural operations to be performed in, page 1193.  
 June, weather and agricultural operations to be performed in, page 1193.
- K.
- Kali plant, *Salsola kali* (figured), 1120.  
 Keith, George Skene, D.D., his work on agriculture, page 1170. A. D. 1811.  
 Kelp, or sea weed, its growth and manufacture, 5529.  
 Kent, agricultural survey of, 6995.  
 Kent, Nathaniel, Esq. his works on agriculture, page 1165. A. D. 1775.  
 Kentish and Hertfordshire wheel ploughs, 2514.  
 Kerr, Robert, surgeon, F.R. & A.S.S., his work on agriculture, page 1169. A. D. 1809.  
 Kerry, agricultural survey of, 7093.  
 Kidney bean, its field culture, 4321.  
 Kildare, agricultural survey of, 7080.  
 Kilkenny, agricultural survey of, 7079.  
 Killing animals, different modes of, considered, 2046.  
 Kincardineshire, or Mearns, agricultural survey of, 7065.  
 King's county, agricultural survey of, 7081.  
 Kinross-shire, agricultural survey of, 7061.  
 Kirby, Christopher, his work on the effects of thunder and lightning on wheat, &c., page 1163. A. D. 1673.  
 Kircudbrightshire, agricultural survey of, 7054.  
 Kirkpatrick, H., his work on agriculture, page 1167. A. D. 1796.  
 Kirwan, Richard, Esq., LL.D., F.R.S.L. and E. and P.R.I.A., his work on agriculture, page 1167. A. D. 1796.  
 Kitchen garden of the farmer, 2754.  
 Knapp, J. L., Esq., his work on grasses, page 1169. A. D. 1804.  
 Knees, broken, in horses, 5837.  
 Knollwall farm, 3860.  
 Krantz, Guillaume, his work on agriculture, page 1176. A. D. 1797.  
 Kruntz, J. G., his work on agriculture, page 1176. A. D. 1773.  
 Kylee breed of cattle, 6120.
- L.
- Laboring animals of the Romans, 93; their food, 100; breeding, 94; breaking and training, 98; working, 101.  
 Lacoste, his work on agriculture, page 1174. A. D. 1801.  
 Lactometers, 6310.  
 Ladders, 2448.  
 Ladnar, his work on agriculture, page 1164. A. D. 1764.



- Ladrones, agriculture of, 1031.  
*Lafaille*, Clement, his works on agriculture, page 1172. A. D. 1762.  
*Laffens*, Barthélemy de, his work on agriculture, page 1171. A. D. 1604.  
*Lajons*, M. de, his work on agriculture, page 1175. A. D. 1821.  
 Lama Camel, 6631.  
 Lamb, house or early, how produced for the London market, 2043, see Sheep.  
*Lambert's* mole plough, 2523; Weir's improvement on Lambert's working power, 2524.  
 Lambs, diseases of, &c. 6529; see Sheep.  
*Lamoignon*, Malesherbes, Chretien-Guillaume, his work on agriculture, page 1173. A. D. 1791.  
*Lampadius*, Augusto Guglielmo, his work on agriculture, page 1173. A. D. 1811.  
 Lampas, or mouth disease, 5777.  
 Lanarkshire or Clydesdale, agricultural survey of, 7056.  
 Lancashire, or long-horned breed of cattle, 6108. |  
 Lancashire, agricultural survey of, 7027.  
 Land guard for river banks, 4041.  
 Land levelling machine, 2587.  
 Land surveying required of the agriculturist, 3054.  
 Landed property, tenures of, 3144; see Tenures.  
 Landed estates, to lay out, 3224; consolidating detached property, 3223; appropriating commonable lands, 3233; choice of a site for the demesne, 3263; roads, 3263.  
 Landed property, management of, 4262; superintendants, 4264; steward, 4265; resident manager, 4267; acting manager, 4268; land reeve, 4276; under steward, 4277; law assistant, 4278; land surveyor, 4280; place of business, 4281; duties of managers, 4296; general principles of business, 4297; management of tenants, 4303; letting farms, 4309; species of tenancy, 4310; rent and covenants of a lease, 4326; receiving rents, 4337; keeping and auditing accounts, 4343.  
 Landed property throughout Germany, 545; in modern Egypt, 1049; in Jamaica, 1175; at the Cape of Good Hope, 1091; in the United States, 1134; in Sweden, 670; in Spain, 693; in ancient Egypt, 13; of Persia, 853; in Poland, 629; among the Jews, 31; in Java, 931; in Hindustan, 880; in China, 953; in Russia, 653; in Switzerland, 328; among the ancient Greeks, 21; in Austria, 608; among the Romans, 53; in Holland, 419; in Savoy, 348; price of, among the Romans, 169; in Ireland, 809.  
 Landed property, its valuation, 3165; its purchase or transfer, 3212.  
*Landeschi*, his work on agriculture, page 1173. A. D. 1817.  
*Langford*, T., his work on agriculture, page 1163. A. D. 1681.  
 Language used to horses, 5985.  
 Laos, agriculture of, 942.  
 Lark, Alauda, 6791.  
 La Société d'Agriculture de Paris, its work on agriculture, page 1175. A. D. 1825.  
*Lasteyrie*, Charles Philibert de, his works on agriculture, page 1174. A. D. 1799.  
*Lastri*, Proposto, his work on agriculture, page 1177. A. D. 1793.  
*Lawrence*, Edward, his work on agriculture, page 1163. A. D. 1727.  
*Lawrence*, John, his works on agriculture, page 1167. A. D. 1796.  
*Lawrence*, John, his work on agriculture, page 1164. A. D. 1726.  
*Lawson*, J., his work on agriculture, page 1164. A. D. 1797.  
 Lavendar, 5521.  
 Layers of plants to propagate by, 1319.  
 Laying out farm and cottage lands, 3835; size of farms and cottage lands, 3836; cottage farms, 3839; farmery, 3851.  
 Leases granted to farmers, different species of, 4310; at will, 4311; from year to year, 4312; for a term of years certain, 4313; for lives, 4314; for twenty years, 4322; perpetual lease, 4323; rent and covenants, 4326.  
 Leases, origin of, in Scotland, 749.  
 Leases in Ireland, 811.  
 Leases, long, or improving, the foundation of the progress of agriculture in Scotland, 744.  
*Leatham*, Isaac, his work on agriculture, page 1167. A. D. 1794.  
 Leaves of plants, their great importance in elaborating the sap, 1524.  
 Leaves of plants to propagate by, 1616.  
*Lebrocq*, Philip, M.A., his plan for improving the New forest, page 1166. A. D. 1793.  
*Lee*, H. P., Esq., his description of a new threshing machine, page 1170. A. D. 1811.  
 Leech, medicinal, 6845.  
 Leguminous field plants, their culture, 4737; nutritive products of leguminous plants, 4738.  
 Leicestershire, agricultural survey of, 7013.  
 Leitrim, agricultural survey of, 7097.  
 Lemon of Abyssinia (figured), 1042.  
 Lentil, its culture, 4815.  
 Lepidopterous insects, 6388.  
*Lerouge*, his work on agriculture, page 1173. A. D. 1774.  
*Lesbros-de-la-Versanc*, Louis, his work on agriculture, page 1172. A. D. 1763.  
*Lester*, William, his works on agriculture, page 1169. A. D. 1803.  
*L'Etang*, de la Salle, Simon Philibert de, his work on agriculture, page 1172. A. D. 1762.  
*Leteltier*, his work on agriculture, page 1171. A. D. 1602.  
 Lettuce, field culture of, 4931.  
 Levelling harrow or brake, 2573.  
 Levelling harrow, 2590.  
 Levelling staff, 2425.  
 Levelling machine, 2587.  
 Levels, 2420; masons' level, 2421; water level, 2422; American level, 2423; square level, 2424.  
 Levels, to ascertain, 3059.  
 Lever, 2374.  
*Ley*, Charles, his work on the management of estates, &c., page 1166. A. D. 1787.  
 Lichen rangiferinus (figured), reindeer moss, 675.  
 Lichen roccella (figured), the archil or dyers' moss of the Canary islands, 1120.  
 Lichenæ or lichens, utility of, 1308.  
*Liger*, Louis, his works on agriculture, page 1171. A. D. 1703.  
 Light, its agency in vegetable culture, 2246.  
 Light, 2258.  
 Light in respect to the culture of vegetables, 1792.  
 Light, its influence on the distribution of vegetables, 1726.  
 Lightning, theory of, 2328.  
 Lime, application of, 4588; mixture of with earth and dung, 4593; application of, by Dawson of Frogden, 4591.  
 Lime kilns, different kinds of, 3587.  
 Lime kilns of Jamaica, 1181.  
 Lime, burning of, 3587; kilns, 3588.  
 Lime, theory of its operation on soils, 2218; see Mineral manures, different species of, 2217.  
 Limerick, agricultural survey of, 7091.  
 Limes of Brazil (figured), 1208.  
 Limestone of South Wales, 7045.  
 Limestone to burn in kilns, 3587; in heaps, 3590; to reduce by pounding, 3591.  
 Lincolnshire, agricultural survey of, 7016.  
 Line and reel, 2416.  
 Linlithgowshire, agricultural survey of, 7059.  
 Linseed cake, theory of its operation as a manure, 2173.  
 Liquid manure of Flanders, 474.  
 Liquorice, 5516.  
*Liste*, Edward, Esq., his works on agriculture, page 1164. A. D. 1757.  
*Lister*, Martin, M.D., his works on agriculture, page 1163. A. D. 1683.  
 Literature and bibliography of British agriculture, 7108.  
*Little*, John, his work on agriculture, page 1170. A. D. 1815.  
 Live stock, choice of, 4462; for the purposes of labour, 4463; oxen, 4464; horses, 4468; for breeding, 4470; for feeding, 4482.  
 Live stock, history of Bakewell's improvements on, 765.  
 Live stock, buildings for, 2661.  
 Live stock, economy of, 5546.  
 Live stock of Herefordshire, 7009.  
 Live stock of Flanders, 510; horse, 511; shoeing, &c., 513.  
 Liver, chronic inflammation of, 5810.  
 Liver diseases, in horses, 5810.  
*Livingston*, Chancellor, his essay on sheep, page 1170. A. D. 1811.  
*Livy*, Cav., his work on agriculture, page 1177. A. D. 1800.  
 Loango, agriculture of, 1081.  
*Loch*, James, Esq., his work on the improvements of

- the estates of the Marquess of Stafford, 7010; his opinion as to hedgerow timber, 3900.
- Locked jaw, or tetanus in horses, 5763.
- Locked jaw, or tetanus in cattle, 6271.
- Lombardy poplar, the oldest in England, 6996.
- Londonderry, husbandry of, 799; agricultural survey of, 7104.
- Long journeys, how to feed and prepare animals for, 2045.
- Long-horned, or Lanoashire cattle, 6108.
- Longford, agricultural survey of, 7086.
- Looseness, or diarrhoea, 5804.
- Lord Somerville's drag-cart, 2615.
- Losana*, Matteo, his work on agriculture, page 1178. A. D. 1811.
- Loudon*, John, F.L.S. H.S., his work on agriculture, page 1170. A. D. 1811.
- Louse, *Pediculus*, 6912.
- Louth, agricultural survey of, 7087.
- Lov*, Davil, Esq., his work on agriculture, page 1171. A. D. 1823.
- Lowe*, Alexander, Esq., his work on agriculture, page 1167. A. D. 1794.
- Lowe*, Robert, Esq., his work on agriculture, page 1167. A. D. 1794.
- Luccock*, John, his works on wool, page 1169. A. D. 1805.
- Lucern, culture of, 5025.
- Lüders*, Ph. E., his work on agriculture, page 1176. A. D. 1769.
- Lullin*, J. M., his works on agriculture, page 1178. A. D. 1812.
- Lullin*, Ch. L. M., his work on agriculture, page 1175. A. D. 1819.
- Lungs, inflammation of, 5783.
- Lupin, its field culture, 4822.
- Lycopodium complanatum* (figured), 677.

## M.

- Machine for reaping clover heads, 2005.
- Machine for mowing clover, 2606.
- Machines for reaping and gathering crops, 2591; horse rakes, 2592; haymaker, 2597; hay sloop, 2598; reaping machines, 2599.
- Machines for sowing and planting, 2551; Cooke's corn-drill, 2552; Norfolk corn drill, 2553; Cooke's three-row drill, 2554; French's turnip drill, 2556; Northumberland one-row drill, 2557; bean drill, 2558; Weir's bean drill, 2559; bean dibbler, 2561; block plough drill, 2562; drill roller, 2563; drill watering machine, 2564.
- Machines for laying land level, 2587; British, 2588; Flemish, 2589.
- Machines for washing roots, 2653.
- Machines for threshing and cleaning corn, 2625.
- Machines of deportation, 2607; carts, 2608; wag-gons, 2619.
- Machines for steaming food, — see Steaming machines.
- M'Adam's* theory and practice of road making, 3333.
- Macdonald*, James, M.A., his work on agriculture, page 1170. A. D. 1811.
- M'Evoy*, John, his work on agriculture, page 1168. A. D. 1802.
- Mackenzie*, Sir George Stewart, Bart. F.R.S.S. L. & E., his work on sheep, page 1169. A. D. 1809.
- M'Parlan*, James, M.D., his works on agriculture, page 1168. A. D. 1802.
- Macphail*, James, his work on agriculture, page 1167. A. D. 1795.
- Macwilliam*, Robert, his essay on the dry rot, page 1170. A. D. 1818.
- Madagascar, agriculture of, 1115.
- Madder, its culture and management, 5350.
- Madder, culture of, in Flanders, 479.
- Madeira, agriculture of, 1121; system of cultivation, 1122; vine, 1123; wheat, 1124; live stock, 1125; fruits, 1126.
- Madness, canine, 6660.
- Magnesian limestone, theory of its operation on soils, 2227.
- Mahogany tree, *Swietenia mahogani* (figured), 1173.
- Mahometan states of the north of Africa, agriculture of, 1066.
- Maidenhair tree, *Salisburia adiantifolia*, in China, 973.
- Maize, or Indian corn, its culture, 4734.
- Maize, culture of, in the West Indies, 1197.
- Maize (figured), its culture in America, 1145.
- Malacca, agriculture of, 938.
- Malignant fever in horses, 5767.
- Malignant epidemic, or murrain, in sheep, 6507.
- Mallenders and sellenders, 5836.
- Malcolm*, James, his work on agriculture, page 1169. A. D. 1805.
- Malcolm*, W. J. & J., their works on agriculture, page 1167. A. D. 1794.
- Malenotti*, Ignazio, his work on agriculture, page 1178. A. D. 1815.
- Mallet*, Robert Xavier, his work on agriculture, page 1173. A. D. 1780.
- Malting barley, process of, 4687.
- Mammalia noxious to agriculture, 6847.
- Management of landed property, — see Landed property, management of.
- Manager of a landed estate, 4264; his duties, 4296.
- Mandiocca, cassava, or manioc, *Jatropha manihot*, its culture in Brazil, 1212; in various countries, 1073.
- Mandrake (figured), 1057.
- Mange, 5818.
- Mango (figured), 1186.
- Mangold root, or mangold würczel, culture of, 4962.
- Mangostan (figured), a fruit of Hindustan, 896.
- Manillas, or Philippine Islands, agriculture of, 1022.
- Manioca, *Jatropha manihot*, see Mandiocca.
- Manna, *festuca fluitans*, its culture in Russia, 656.
- Manna, cultivation of, in Calabria, 323.
- Manual labors of agriculture, 2876.
- Manual operations of agriculture of a mixed kind, 2946.
- Manufactories, their establishment on estates, 3567.
- Manufactures and trades in Derbyshire, enumeration of, 7014; 1st, on animal products of the country: 2d, animal substances imported: 3d, on vegetable productions of the country: 4th, on vegetable substances imported: 5th, on mineral products of the country: 6th, on mineral substances imported, 7014.
- Manure, its collection and preservation in China, 991; vegetable ashes, 992; plaister of old kitchens, 993; night soil, 994; dung and urine of animals, 995; lime, 996; mixture of soils, 1000; application of manure in China, 997.
- Manures of animal and vegetable origin, their different species, 2169; green succulent plants, 2170; rape cake, 2171; malt dust, 2172; linseed cake, 2173; sea weeds, 2174; dry straw, 2175; woody fibre, 2176; inert peaty matter, 2177; tanner's spent bark, 2178; wood ashes, 2179; manures from animal substances, 2180; muscles, 2181; fish, 2182; oily substances, 2183; bones, 2184; horn, 2185; hair, 2186; blood, 2188; urine, 2191; night soil, 2195; dung of fowls, 2197; dung of cattle and sheep, 2199; dung of horses, 2201; soot, 2204.
- Manures, management of, 4579; farm yard dung, 4580; lime, 4588; composts of earth, lime, and dung, 4593; meadowbank middens, 4595.
- Manures of mineral origin, 2213; theory of their operation, 2214; different species, 2217.
- Manures, to preserve, ferment, and apply, 2205.
- Manures, 2161; of animal and vegetable origin, 2162; of mineral origin, 2213.
- Manures in use in Flanders, 487.
- Manuring among the Romans, 129.
- Maps of estates, different modes of finishing, 3106.
- March, weather and agricultural operations to be performed in, page 1190.
- Marchand*, Jean-Henri, his work on agriculture, page 1172. A. D. 1768.
- Mares, treatment of, during pregnancy, 5971.
- Mares and foals, treatment of, 5976; weaning the foal, 5977; gelding, 5981.
- Marian grass, or spurry, *Spergula arvensis*, 475.
- Marine plants used in agriculture, 5528.
- Market garden of Mellor in Derbyshire, perfection and utility of its arrangement, 7014.
- Markham*, Gervase, Jervise, or Gervas, his works on agriculture, page 1162. A. D. 1593.
- Marking with the line, 2889.
- Marking plough, 2503.
- Marl, as known to the Romans, 130.
- Marl, use of, at Trentham, 7011.
- Marquesas, agriculture of, 1033.
- Marrriot*, William, his law book relative to agriculture, page 1167. A. D. 1795.
- Marshall*, William, Esq., his works on agriculture, page 1165. A. D. 1778.
- Mascall*, Leonard, his works on poultry, &c. page 1162. A. D. 1581.

- Materials, to estimate their value, 3085.  
*Mather*, John, his work on agriculture, page 1170. A. D. 1820.  
*Mathieu de Dombasle*, C. J. A., his work on agriculture, page 1175. A. D. 1824.  
 Mattock, — see Pick.  
*Maunsell*, William, L.L.D., his work on agriculture, page 1167. A. D. 1794.  
*Maupin*, his works on agriculture, page 1173. A. D. 1779.  
 Mauritius, or Isle of France, agriculture of, 1116.  
 Maxims of farm management among the Romans, 157.  
*Maxwell*, an eminent Scottish improver and writer, 784.  
 May, weather and agricultural operations to be performed in, page 1192.  
*May*, Thomas, his work on agriculture, page 1166. A. D. 1792.  
*Mayet*, Etienne, his work on agriculture, page 1173. A. D. 1790.  
 Mayo, agricultural survey of, 7096.  
 Mead, brewing of, in Poland, 642.  
 Meadow lands of France, 390.  
 Meadow lands, management of, 5197; irrigated, 5199; upland meadows, 5200; — see Irrigation, and Pasture lands.  
 Meadow hay, process of making, 5217; hay tedding machine, 5225; stacks, 5226; hay of bog meadows, to make, 5229; hay of florin, 5232.  
 Meadow water, how to construct, 4104.  
 Meadowbank middens, how to form, 2177.  
 Meadowbank middens, 4595.  
 Meadows, irrigated, 4093; flowing, 4094; catch work, 4095.  
*Meager*, Leonard, his work on agriculture, page 1163. A. D. 1699.  
 Mearns, agricultural survey of, 7065.  
 Measuring chain, 2427.  
 Measuring land, 3054.  
 Mechanical operations common to all arts of manual labor, 2877; lifting, 2878; carrying, 2879; drawing, 2880; pushing or thrusting, 2881; wheeling, 2882.  
*Medicago falcata* (figured), or Swiss lucern, 5026.  
 Medicines for horses and cattle, 5879.  
 Megrimis, 5769.  
 Meikle's threshing machines, 2638; smut machine, 2643; awn separator, 2649.  
 Melampyrum pratense (figured), cow wheat, 424.  
*Melilotus officinalis* (figured), used to scent the Gruyère cheese, 342.  
 Melon, winter, its culture in France, 415.  
 Mens' sleeping rooms, 2710.  
*Menzies*, Michael, inventor of the threshing machine, 777.  
 Merino sheep, history of their introduction to Britain, 769; treatment of, 6407.  
 Merino or Spanish sheep, 6407.  
 Merino sheep, when introduced into France, 375.  
*Merton's* universal drill plough and harrow, 2545.  
 Mesta, or united flock of sheep; a term applied to the Merino flocks in Spain, 716.  
 Metaliferous ores, 3593.  
 Metayers of Lombardy, 265; of the Neapolitan territory, 313.  
 Mexico, agriculture of, 1150; climate, 1150; surface, 1151; soil, 1152; floating fields, 1154; irrigation, 1157; maize, 1158; field labors, 1159; woods, 1162; breeding of animals, 1163; Mexican cochineal, 1164; fruits, 1165.  
 Middle horned cattle, 6111.  
 Middlemen in Ireland, 834.  
 Middlesex, agricultural survey of, 6992.  
*Middleton*, John, Esq., his works on agriculture, page 1168. A. D. 1798.  
 Mid-lothian, agricultural survey of, 7047.  
 Migration of animals, 1969.  
 Mildew, a disease of plants, 1659.  
 Milk, its management, 6316.  
 Milk, its chemical properties and general principles, 6284.  
 Milk, different preparations of, 6369.  
 Milk barrow in use in Derbyshire, 7014, fig. 792.  
 Milk syllabub, 6377.  
 Milk tankard, 7005, fig. 778.  
 Milking, and the management of milk, 6315.  
 Millet, *Holcus sorghum*, its culture in China, 979.  
 Millet, different kinds of, and their culture, 4721.  
 Mills for raising water in Flanders, 444.  
 Mills, their establishment on estates, 3561; steam mills, 3564; water mill, 3565; grist mills, 3566.  
*Mills*, John, F.R.S., his works on agriculture, page 1164. A. D. 1759.  
 Mineral kingdom, its study with reference to agriculture, 2053; earths and soils, 2064; manures, 2161.  
 Mineral manures, different species of, 2217; alkaline earths, 2217; lime, 2218; burnt lime, 2219; quick lime, 2220; mild lime, 2221; effect of lime on wheat crops, 2222; general principles for applying lime, 2223; different kinds of limestone, 2225; magnesium limestone, 2227; gypsum, 2229; phosphate of lime, 2235; bone ashes, 2236; saline magnesia, 2237; wood ashes, 2238; soda, 2239.  
 Mineral manures, 2213.  
 Mineral manures, theory of their operations on soils and plants, 2214; saline, 2214.  
 Mineral poisons, 5792.  
 Minerals and mines, — see Mines.  
 Mines and minerals, their establishment or working on estates, 3578; coal mines, 3580; limestone, chalk, and stone, 3584; salt, 3592; metals, 3593.  
 Mining plough, 2497.  
 Minnow, 6810.  
 Mint, 5524.  
 Mites, cheese, 6913.  
 Models of estates, 3119.  
 Moisture, in respect to the culture of vegetables, 1791.  
 Moisture, its influence on vegetables, 1699.  
 Moldavia and Wallachia, agriculture of, 738.  
 Mole, to destroy, 6854.  
 Mole traps, 2475.  
*Molesworth*, Robert, Viscount, his work on agriculture, page 1164. A. D. 1723.  
 Moluccas, or Spice islands, agriculture of, 1024.  
 Monaghan, agricultural survey of, 7101.  
*Monk*, John, his works on agriculture, page 1167. A. D. 1794.  
 Monks of Congo, 1086.  
 Monmouthshire, agricultural survey of, 7008.  
*Moore*, Sir Jonas, Knt. F.R.S., his works on agriculture, page 1163. A. D. 1685.  
 Moors, to improve, 4181.  
 Moose deer, C. alces, 6522.  
 Morasses and bogs, to improve, 4183.  
 Morayshire, agricultural survey of, 7067.  
*Mordant*, John, his work relative to stewards, page 1164. A. D. 1761.  
*Morel de Vinde*, his works on agriculture, page 1174. A. D. 1807 and 1822.  
 Morel, Phallus esculentus (figured), 1310.  
 Morfoundering or catarrhal fever in horses, 5765.  
*Morgan*, John, M.D. F.R.S., his works on agriculture, page 1164. A. D. 1766.  
*Moricc*, Francis, his work on agriculture, page 1171. A. D. 1824.  
*Morley*, Christopher, his work on agriculture, page 1167. A. D. 1797.  
*Morley*, John, his work on manure, page 1170. A. D. 1811.  
 Morocco, agriculture of, 1072; manure and culture, 1073; live stock, 1074; nomadic cultivators, 1075.  
*Morogues*, Baron de, his work on agriculture, page 1175. A. D. 1822.  
*Mortemart-Boisse*, le Baron de, his work on agriculture, page 1175. A. D. 1824.  
*Mortimer*, John, his work on agriculture, page 1163. A. D. 1707.  
 Moss cutting machine of General *Dirom*, 7053.  
 Mosses and bogs, to improve, 4183.  
 Moths, 6894.  
*Moubray*, Bonnington, Esq., his treatise on poultry, page 1170. A. D. 1815.  
 Mouldebaert, an implement for levelling, in use in Flanders, 501.  
 Moulding sledge, 7022.  
 Mountainous and hilly grounds, to improve, 4160.  
 Mouse, to destroy, 6859.  
 Mouse traps, 2475.  
 Mouth ill, or lampas, 5777.  
 Moutiers, salt works of, 370.  
 Mowing, 2930; grain, 2931; grass, 2932; woods, 2934; weeds in rivers, 2934; with the Hainaut scythe, 2936.  
 Mulberry, culture of, in Tuscany, 287.  
 Mulberry, its culture in Hindustan, 884.  
 Mulberry, its culture in France, 408.  
 Mulberry, culture of, in Germany, 550.  
 Mule, among the Romans, 106.  
 Mule and hinny, 6098; breeding, 6102; shoeing, 6103.  
 Mules of Persia, 859.

*Munnings*, Rev. Thomas Crowe, his work on agriculture, page 1169. A.D. 1803.  
*Munro*, Col. Innes, his guide to farm book-keeping, page 1170. A.D. 1822.  
 Murrain or pest, 5767; in sheep, 6507; in cattle, 6249.  
 Muscovy duck, *Anas Moschata*, 6738.  
 Mushroom, *Agaricus campestris* (figured), 1310.  
 Music, its influence on the stag, 6617.  
 Music, its use in fattening pigs in Mexico, 1163.  
 Mustard, cultivation of, in Yorkshire, 7021.  
 Mustard, culture of, in Hindustan, 887.  
 Mustard, its culture as an oil plant, 5475; for other purposes, 5479.  
*Mustella ferro*, the ferret, 6671.  
*Myoxus glis*, the dormouse, 6615.  
 Myrrh, from what plant obtained, 1455.

## N.

Nainshire, and Morayshire, agricultural survey of, 7067.  
*Naismith*, John, his works on agriculture, page 1166. A.D. 1790.  
 Naked disease in sheep, 6521.  
*Nan*, Rh. Seb., his work on agriculture, page 1176. A.D. 1791.  
*Napier*, Hon. Wm. John, F.R.S. Edin., his treatise on store farming, page 1170. A.D. 1822.  
 Narcotic principle, from what plants obtained, and how used, 1396.  
 Neat, or horned cattle, 6104.  
 Neck, diseases of, 5780, 5782.  
 Neglected plantations, to improve, 3718.  
 Nelumbium, its culture in China, 977.  
 Nests for poultry, 6679.  
 Netherlands, agriculture of, 422; secret of Flemish husbandry, 425; climate and surface, 427; landed property, 430; farmeries, 431; arable lands, 435; fallows, 436; polders, or embanked lands, 440; rotations, 445; crops, 453.  
 Neuropterous, or nerve-winged insects, 6896.  
*Neue-Eglise*, Louis-Joseph Bellepierre de, his works on agriculture, page 1172. A.D. 1761.  
 New Britain, agriculture of, 1027.  
 New Brunswick and Nova Scotia, agriculture of, 1170; Cape Breton, 1171.  
 New Caledonia, agriculture of, 1027.  
 New Forest in Hampshire, 7029.  
 New Hebrides, agriculture of, 1027.  
 New Holland, agriculture of, 1025.  
 New Ireland, agriculture of, 1027.  
 New Zealand, agriculture of, 1023.  
 New Zealand hemp, 1023.  
*Newby*, Thomas, his work on the mangel wurzel, page 1170. A.D. 1813.  
 Newstead farm, 3861.  
 Nicking, docking, and cropping, in horses, 5877.  
 Night soil, as a manure, 2195.  
 Nighau, or white-footed antelope, 6628.  
 Norfolk, agricultural survey of, 7003.  
 Norfolk cart and waggon, 2623.  
 Norfolk wheel plough, 2516.  
 Norfolk horse rake, 2593.  
 Norfolk drill roller, 2584.  
 Norfolk corn drill, 2553.  
 Noria, or bucket wheel of Spain (figured), 723.  
 Noria of the Alps (figured), 368.  
 Norland, or North Highland, cattle, 6122.  
 Norman clergy great agriculturists, 205.  
*North*, Richard, his work on agriculture, page 1164. A.D. 1760.  
*North*, Roger, his history of esculent fish, &c., page 1167. A.D. 1794.  
 North America, agriculture of, 1127; climate, 1127; surface, 1128; general character, 1129; United States, 1130; Mexico, 1150; British possessions, 1166; West India islands, 1172.  
 North Riding of Yorkshire, agricultural survey of, 7021.  
 Northamptonshire, agricultural survey of, 7018.  
 Northumberland turnip drill, 2555; one-row drill, 2557.  
 Northumberland horse hoe, 2541.  
 Northumberland, agricultural survey of, 7024.  
 Nottinghamshire, agricultural survey of, 7015.  
 Notts, or horules sheep, 6394.  
 Nova Scotia, agriculture of, 1170.  
 November, weather and agricultural operations to be performed in, page 1195.  
 Nubia, agriculture of, 1065.  
 Nutmeg tree, culture of, in the Spice islands, 1024.

Nutrition of vegetables, 1511; see Vegetable nutrition.

## O.

Oak of China, 972.  
 Oak tree, *Phoenix dactylifera*, culture of, in Persia, 855.  
 Oat, culture of, 4694; species and varieties, 4695; soil, 4706; sowing, 4709; harvesting, 4713; kind-drying oats in Russia, 4714; use, 4718.  
 Obea, or eating dirt, a practice among West India slaves, 1199.  
 Obstetrics in cattle, 6275.  
 Occupation of land in Savoy, 350.  
 October, weather and agricultural operations to be performed in, page 1195.  
 Oil of almonds, its manufacture, 1411.  
 Oil of poppy, its uses, 1417.  
 Oil mills of the Chinese (figured), 967, 968, 989.  
 Oil plants, 5458.  
 Oil plants of Hindustan, 887.  
 Ointments used for horses, cattle, sheep, &c., by veterinary practitioners, 5921.  
*Olea europea* (figured), the olive, 731.  
 Olive, its culture in France, 410.  
 Olive, its culture in Spain, 706.  
 Olive, culture of, in Tuscany, 289.  
 Olive oil, how manufactured, 1410.  
 Olives, 731; almonds and carobs, 733; forests, 736.  
*Olivier*, G. A., his work on agriculture, page 1174. A.D. 1792.  
*Onorati*, Nicola Columella, his works on agriculture, page 1178. A.D. 1816.  
 Operating with the cultivator, grubber, &c., 3019.  
 Operations of agriculture, 2875; manual labors and operations, 2876; operations with laboring cattle, 2992; scientific operations, 3052.  
 Ophthalmia, 5771.  
 Orange and pomegranate in Spain, 710.  
 Orange, its culture in France, 414.  
 Orange in Persia, 856.  
 Orchard attached to the farmery, 2755.  
 Orchards, their formation and management, 3770; soils and situations, 3771; sorts of trees, 3776; manner of planting, 3793; cultivation of farm orchards, 3797; gathering and keeping of orchard fruits, 3807.  
 Orchards of Clydesdale, 7056.  
 Orchards of Herefordshire, 7009.  
 Orchards of Gloucestershire, 7006.  
 Orchards of Roxburghshire, 7050.  
 Orchards of Worcestershire, 7007.  
 Orchis, or Salep plant, 5526.  
 Orkney and Zetland cattle, 6123.  
 Ornamental cottages, 2734.  
 Orobanche major (figured), broom rape, a noxious weed in the clover grounds of Flanders, 463.  
 Osier grounds, their management, 3738.  
 Otaheite, agriculture of, 1035; soil, 1036; produce, 1037; live stock, 1038.  
 Over-reach, or treads on the feet of horses, 5859.  
*Ovis strepsiceros* (figured), the Hungarian sheep, 619.  
*Owen*, Rev. T., M.A., his work on agriculture, page 1168. A.D. 1800.  
 Ox or bull family, 6105; varieties, 6106; criteria of qualities in the bull family, 6135.  
 Ox of Hindustan, 899.  
 Ox of Thibet, *Bos grunniens*, 869.  
 Oxen of Abyssinia, 1043.  
 Oxen of the Romans, 100.  
 Oxen as laboring cattle, 4464.  
 Oxen, shoeing of, 6219.  
 Oxen, working of, 6125.  
 Oxfordshire, agricultural survey of, 7004.  
 Oxygen as a constituent part of the atmosphere, 2274.  
 Oyster fisheries, 3604.  
 Oysters, breeding and rearing of, near Naples, 325.

## P.

*Paillet*, —, his work on agriculture, page 1173. A.D. 1791.  
 Pails, 2439.  
 Paling fences, 2815.  
*Palladius*, R. T. E., his work on agriculture, 50.  
*Pallet*, T., his work on agriculture, page 1168. A.D. 1799.

- Palmyra, its culture and application in Hindustan, 893.
- Palteau*, Guillaume Louis Formanoir de, his work on agriculture, page 1168. A. D. 1768.
- Pan, a term applied to the bed or flooring upon which the cultivated soil lies or is placed. Mr. Marshall, in speaking of the Norfolk soils, remarks, that "immediately under the cultivated soil, a hard crust, provincially 'the pan,' occurs universally. And under this an unfathomable ocean of sand may be considered as the prevailing substratum. In some places a hungry gravel, but more frequently an absorbent brick earth is the immediate subsoil."
- Paue, in irrigation, 4083.
- Panicum miliaceum (figured), or cultivated millet, its culture, 4724.
- Panicum germanicum (figured), or German millet, its culture, 4723.
- Panicum Italicum (figured), or Italian millet, its culture, 4725.
- Papaver, or poppy, culture of, in Flanders, 460.
- Papua, or New Guinea, agriculture of, 1206.
- Paraguay, agriculture of, 1206.
- Paring and burning, mode of performing the operation, 2971; implements, 2973; fenny districts, 2974; western counties, 2975; season, 2976; depth, 2977; spreading the ashes, 2979.
- Paring and burning soils, theory of, 2134.
- Paring wheel-plough, 2517.
- Park fences, 2829.
- Parkinson's* cultivator, 2535.
- Parkinson*, Richard, his works on agriculture, page 1168. A. D. 1799.
- Parmentier*, Antoine Augustin, his works on agriculture, page 1173. A. D. 1781.
- Parmentier*, Deyeux, and others, their work on agriculture, page 1168. A. D. 1782.
- Parmesan cheese, how made in Lombardy, 270.
- Parry*, Caleb Hillier, M. D., F. R. S., his work on agriculture, page 1168. A. D. 1800.
- Parsley field, culture of, 5081.
- Parsnep, culture of, 4951.
- Parsnep, culture of, in Jersey, 7041.
- Parted cast-iron roller, 2580.
- Partridge, 6786; quail, 6787; red grouse, 6788; black grouse, 6789; lark, 6791.
- Partridge, Tetrao perdix, 6785.
- Pastures, their management, 5239; feeding pastures, 5240; weeding, 5242; harrowing, 5243; removing ant and mole hills, 5244; manuring, 5245; teathing, 5246; stocking, 5247; fogging, 5255; water, 5255; salt, 5255.
- Pastures of Hindustan, 897.
- Pastures, their improvement by tillage, 5261; rotation of crops, 5279.
- Pastures, mountainous, their management, 5257.
- Pasturing corn among the Romans, 140.
- Patagonia, agriculture of, 1219.
- Patin*, Charles, his work on agriculture, page 1171. A. D. 1663.
- Pattens for horses, 5939.
- Paved roads, 3439.
- Pavements of Arbroath, 7064.
- Pea, its culture, 4739; varieties, 4740; soil, 4745; sowing, 4747; harvesting, 4752; produce, 4755; use, 4759.
- Peacock, *Pavo cristatus*, 6731.
- Pearce*, William, his work on agriculture, page 1167. A. D. 1794.
- Pears suitable for orchards, 3782. 3784.
- Pearson*, George, M. D., F. R. S., his work on agriculture, page 1169. A. D. 1805.
- Peasantry of Ireland, 830.
- Peat, how to convert to manure, 2177.
- Peat mosses or bogs of Ireland, 807.
- Peat mosses, bogs, and morasses, to improve, 4183.
- Peaty soils, how formed, 2062.
- Peebleshire, or Tweeddale, agricultural survey of, 7052.
- Pelew isles, agriculture of, 1050.
- Pelt rot in sheep, 6521.
- Pendro, a disease in sheep, 6524.
- Penguin, or wild pine apple, *Bromelia penguin*, a hedge plant of the West Indies, 1196.
- Pepper plant, *Piper nigrum* (figured), its culture and application in Sumatra, 1014; white pepper, how prepared in Sumatra, 1015.
- Perch, 6806.
- Peripneumonia, or inflamed lungs in sheep, 608.
- Persia, agriculture of, 850; surface, 851; soil, 852; landed property, 853; agricultural products, 854; fruits, 855; saline deserts, 857; live stock, 858; mules, 859; quail hunting, 860; implements and operations, 861; pigeons, 862; arable culture, 863; forests, 864.
- Perspiration of plants, 1527.
- Perthshire, agricultural survey of, 7063.
- Peru, agriculture of, 1203.
- Pest or murrain in horses, 5767.
- Peters*, Matthew, his works on agriculture, page 1165. A. D. 1770.
- Peyrouse*, Baron Picot de la, his work on agriculture, page 1175. A. D. 1819.
- Pharmacopœia in horses and cattle, 5879.
- Pheasant, *Phasianus colchicus*, 6779; varieties, 6780; breeding, 6781; stocking, 6782; feeding, 6784; fancy pheasants, 6785.
- Phillips*, Robert, his work on roads, page 1164. A. D. 1737.
- Phœnicia, its agriculture, 57.
- Phrenitis, or inflammation of the brain in horses, 5760.
- Physicking of horses, 5874; process, 5876.
- Physiology and anatomy of the bull family, 6227. 1
- Physiology and anatomy of the sheep, 6497.
- Physiology of insects, 6863; eggs, 6864; caterpillars, 6866; chrysalis or pupa state, 6867; sexes, 6868; duration, 6869; scientific arrangement, 6870.
- Phytography, or the naming and describing of plants, 1269.
- Piacenza*, Giovanni, his work on agriculture, page 1177. A. D. 1805.
- Pick or mattock, 2375.
- Picking, 2886.
- Pictet*, Charles, his works on agriculture, page 1174. A. D. 1802.
- Piers to guard river banks, their construction, 4040.
- Pigeon, *Columba*, 6764; variety, 6765; stocking, 6767; breeding, 6768; food, 6770; salt, 6771; cleanliness, 6772; pigeon houses, 6773; diseases of pigeons, 6777; laws respecting pigeons, 6778.
- Pigeon houses of Persia, 862.
- Pigeon dung, its importance in Persia, 862.
- Pigeon houses, 6773.
- Pigeonry, 2686.
- Pigs of the Cape of Good Hope, 1105.
- Pike, 6808.
- Pilchards, use of, as manure in Cornwall, 7039.
- Pilchard fishery, 3602.
- Pincers, or thistle drawers, 2394.
- Pine woods in Inverness-shire, 7071.
- Pining in sheep, 6517.
- Pinus pinea* (figured), its seeds eaten in Italy, 395.
- Pitch and tar, from what plants obtained, and how manufactured and used, 1429.
- Pithing animals described, and physiologically considered, 2047.
- Pitt*, William, his works on agriculture, page 1167. A. D. 1794.
- Plague, a disease of hogs in Poland, 642. 1
- Plaster of Paris; — see Gypsum.
- Plans, different modes of finishing, 3106.
- Plant louse, *Aphis*, 6884.
- Plantain, *Musa sapientum* (figured), 1027.
- Plantain, *Musa paradisiaca*, culture of, in the West Indies, 1193.
- Plantain or rib wort, culture of, 5070.
- Plantations, 3627; soils and situations for trees, 3631; trees, 3638; formation, 3642; enclosing, 3643; planting and sowing, 3645; mixture of sorts, 3669; culture of the soil, 3679; filling up blanks, 3683; pruning and heading down trees, 3687; thinning, 3709; neglected plantations, 3718; diseased trees, 3724; products of trees, 3734; felling and cutting, 3739; barking, 3748; valuing trees, 3763.
- Plantations in North Wales, 7044.
- Planting, 2906; seeds and tubers, 2907; plants, 2908; preparation, 2909; insertion, 2910.
- Planting trees, different methods of, 3659.
- Plants, their products; — see Vegetable products.
- Plants grown for medicinal purposes, 5510; saffron, 5511; liquorice, 5516; rhubarb, 5518; lavender, 5521; thyme, wormwood, &c., 5522; chamomile, 5523; mint, 5524; valerian, 5525; salep or orchis, 5526.
- Plants grown for their produce in oil, 5458; rape, 5459; mustard, 5475; poppy, 5476; sunflower, 5477.
- Plants cultivated for their roots or leaves, 4823; their nutritive products, 4824.
- Plants cultivated for the arts and manufactures, 5290; for the clothing arts, 5291; brewery and distillery, 5392.

- Plants used in the brewery and distillery, their culture, 5392; the hop, 5393.
- Plants, their systematic distribution, 1740.
- Plants, study of, 1264; — see Vegetable kingdom.
- Plants, their food, 1495; water, 1496; gases, 1497; extract, 1502; salts, 1504; earths, 1505; carbon, 1510.
- Plants used in domestic economy, 5478; mustard, 5479; canary grass, 5485; buckwheat, 5499; chess, 5501; chicory, 5503; tobacco, 5505.
- Plants used in the clothing arts, 5291; substitutes for, 5389.
- Plattes*, Gabriel, his works on agriculture, page 1162. A. D. 1638.
- Plough of Arcadia, 731.
- Plough of Tonquin, 945.
- Plough of Yemen, 872.
- Plough of Hindustan, 906.
- Plough of the Romans, 110; wheel ploughs, 113.
- Plough of Osterbothnia, 682.
- Plough of Erzerum, 861.
- Plough of the Samnites, 682; of the ancient Egyptians, 10. 682.
- Plough of Castile, 793; of Valentia, 111.
- Plough of Virgil, 112.
- Plough, Small's, or Scotch (figured), 770.
- Plough of Ceylon, 917.
- Ploughing, 2998; general principles and rules, 2999; kinds of, 3002; relatively to time, 3016; season, 3018.
- Ploughing grass lands, 5261; rotation of crops, 5279.
- Ploughing among the Romans, 127.
- Ploughing in Roxburghshire, 7050.
- Ploughing match at Trentham, 7011.
- Ploughman, Roman, his qualities, 88.
- Ploughman's lodge or bothy, 2709, 2710.
- Ploughmen of Mid-Lothian, their dress and diet, 7047.
- Ploughs with wheels; — see Wheel ploughs.
- Ploughs of China, 987.
- Ploughs, swing, their construction, 2481; by Bailey, 2482; by Small, by Vetch, 2482; other kinds, 2491; 2493; Somerville plough, 2492; turn-wrest swing plough, 2493; Duckett's skim coulter plough, 2494; double share plough, 2496; trenching plough, 2497; double furrow plough, 2498; Argyshire plough, 2499; double mould-board plough, 2500; ribbing plough, 2501; single hoe plough, 2502; marking plough, 2503; Finlayson's rid plough, 2504; Clymer's plough, 2505.
- Pliny*, C. Secundus, his natural history, 49.
- Plum, winesour variety, 7020.
- Plums suitable for orchards, 3787.
- Pneumonia, or inflammation of the lungs, 5786.
- Poison tree of Java, 936.
- Poisons, mineral, 5792.
- Poisons, vegetable, 5794.
- Poland, present state of agriculture in, 628; landed property, 629; post-houses and farms, 630; villages, 630; climate, 631; surface, 632; arable culture, 633; implements and operations, 634; live stock, 635; forests, 636; bees, 637; brewing mead, 642.
- Polecat, to destroy, 6851.
- Pole evil, 5773.
- Polignac*, Comte Charles de, his work on agriculture, page 1175. A. D. 1822.
- Polled, or hornless cattle, 6115.
- Polonceau*, M., his work on agriculture, page 1175. A. D. 1824.
- Polynesian Islands, agriculture of, 1012.
- Polytrichum commune* (figured), one of the most universal of vegetables, 1746.
- Pomeroy*, William Thomas, his work on agriculture, page 1167. A. D. 1794.
- Pond, in irrigation, 4088.
- Ponds, to construct, 4130; ponds of Gloucestershire, 4136; Derbyshire artificial meers, 4137.
- Pontey*, William, his works on trees, page 1168. A. D. 1800.
- Poor, education of, in Devonshire, 7038.
- Poppy, its culture as an oil plant, 5476.
- Poppy, its culture in Hindustan, 885.
- Poppy oil, its uses, 1417.
- Pork and bacon, to cure, 6576.
- Porpoise, the enemy of the salmon, 3613.
- Porta*, J. B., his work on agriculture, page 1175. A. D. 1592.
- Portable or hand-threshing machine, 2453.
- Portugal, agriculture of, 728.
- Pot tree of Brazil, *Lecythis ollaria*, 1210.
- Potatoe, its culture, 4825; history, 4826; varieties, 4832; soil, 4839; planting, 4843; taking the crop, 4856; storing, 4859; produce, 4864; application, 4867; diseases, 4874.
- Potatoe, culture of, in Lancashire, 7027.
- Potatoe in Hindustan, 881.
- Potatoe, culture of, in Flanders, 465.
- Potatoe dibber, 2397.
- Potatoe setscoops, 2417; Edinburgh setscoop, 2418.
- Potatoe drill, 2469.
- Potatoes in Durham, 7023.
- Potatoes, their first introduction to England, 1565.
- Potatoes, culture of, in Ireland, 826.
- Poultices in veterinary surgery, 5867.
- Poultry houses, 2682.
- Poultry houses of Lord Penrhyn, 7028.
- Poultry houses, their furniture and utensils, 6673.
- Poultry, gallinaceous, 6680; anserine or aquatic, 6732; diseases of, 6757.
- Poultry yard, 2752.
- Poultry yard of the Earl of Chesterfield in Derbyshire, 7014.
- Pounding limestone, 3591.
- Preauveau Chemilly*, Eugene, his work on agriculture, page 1174. A. D. 1794.
- Prifontaine*, —, his work on agriculture, page 1172. A. D. 1763.
- Preservation of vegetables, principles of, 1797.
- Pressing plough or roller, 2515. 2585.
- Prevost*, Benedict, his work on agriculture, page 1174. A. D. 1807.
- Price*, John, his treatise on sheep, page 1169. A. D. 1809.
- Pricks in the feet of horses, 5857.
- Pringle*, A., his work on agriculture, page 1167. A. D. 1794.
- Pristly water meadow described, 4107.
- Products of plants; — see Vegetable products. ¶
- Profits of farming among the Romans, 166.
- Profuse staling, or diabetes, 5816.
- Pronged tillage implements, 2527; their merits, 2528.
- Propagation of plants; — see Vegetables, their propagation.
- Pruning knives of Java, 935.
- Pruning of hedges, 3705.
- Pruning, 2916; objects of, 2923; growth, 2924; lessening bulk, 2925; modifying, 2926; adjusting, 2927; renewal, 2928; curing diseases, 2929.
- Prussia, agriculture of, 563; institution of Moegelin, 565; farm of Moegelin, 572; sheep, 574; cows, 576; ploughs, 577; threshing machines, 578; culture of the vine, 579.
- Puceron or aphid, 6884.
- Puckeridge, or wornals in cattle, 6274.
- Pumiced foot, 5852.
- Pumpkins, or vegetable marrow of Cochinchina, (figured), 944.
- Pumps, kinds of, 4154.
- Purging medicines used in veterinary practice, 5915.

Q.

- Quail, Tetrao, 6787; grouse, red, 6788; black, 6789; cock of the wood, 6790.
- Quail, hunting of, in Persia, 860.
- Quails of Tonquin (figured), 945.
- Quarries, their establishment or working, 3587.
- Quassia, or bitter of porter, 1217; cabbage tree beetle, 1217.
- Quayle*, Basil, his work on agriculture, page 1167. A. D. 1794.
- Queen's county, agricultural survey of, 7082.
- Quercus suber (figured), the cork tree, treatment of in Spain, 726.
- Quitor and canker in the feet of horses, 6853.

R.

- Rabbit, 6591; warrens, 6593; tame rabbits, 6600; rabbit house and hutches, 6601; varieties of tame rabbits, 6603; breeding, feeding, &c., 6604.
- Rabbitry, 2685.
- Racing shoe for horses, 5934.
- Rack and manger for colts in use in Leicestershire, 7013; in Derbyshire, 7014.
- Radcliff*, Rev. T., his work on agriculture, page 1170. A. D. 1819.
- Rail roads, 3459.
- Rain, theory of, 2300; phenomena, 2301; cause, 2302; quantity, 2303.
- Rain water, to collect, 4129.

- Rakes, 2380; hay rake, 2381; corn rake, 2382; stubble rake, 2384; daisey rake, 2385; drill rake, 2386.
- Raking by manual labor, 2896.
- Raking with horses, 3030.
- Ralcy, William, his work on agriculture, page 1166. A. D. 1783.
- Rammed earth, or *en pisé* walls, 2848.
- Randall, J., his works on agriculture, page 1164. A. D. 1764.
- Capacity of animals, its influence on their distribution, 1980.
- Rape, culture of, in Flanders, 457.
- Rat, domestic, to destroy, 6855; field rat, 6859. Rat traps, 2475.
- Rauch, F. A., his work on agriculture, page 1174. A. D. 1802.
- Rawson, Thomas James, Esq., his work on agriculture, page 1169. A. D. 1807.
- Ray, or rubbers in sheep, 6522.
- Re, Filippo, his works on agriculture, page 1177. A. D. 1808.
- Reaping, 2937; bagging, 2938; shaving and stacking, 2939; gaiting, 2940; pulling, 2944.
- Reaping among the Romans, 132.
- Reaping hooks, 2406; Hutton's hook, 2407.
- Reaping machine of the Romans, 133.
- Reaping machines, history of, 2599; Boyce's machine, 2600; Plucknet's, 2601; Gladstone's, 2602; Salmon's, 2603; Smith's, 2604; clover pods reaping machine, 2605; clover mowing machine, 2606.
- Rearing animals, principles of, 2020.
- Rearing of horned cattle, 6152.
- Réaumur, René Antoine Ferchault, sieur de, his work on agriculture, page 1171. A. D. 1749.
- Red clover, culture of, in Flanders, 463.
- Red water, or inflammation of the kidneys in cattle, 6262.
- Red water in sheep, 6504.
- Redolfi, Cosimo, his work on agriculture, page 1178. A. D. 1818.
- Reed, mode of thatching with, 2953.
- Reeve, Gabriel, his work on agriculture, page 1163. A. D. 1670.
- Rein deer moss (figured), 675.
- Rein deer, *C. tarandus*, 6623.
- Rennet, its kinds and uses, 6337.
- Rennet of Dutch cheese, 6340.
- Rennie, George, Esq., his work on agriculture, page 1167. A. D. 1794.
- Rent of land in Ireland, 813.
- Renton, George, his work on agriculture, page 1168. A. D. 1801.
- Reports on improvements or valuations, 3121.
- Reproductive system of animals, 1936.
- Resinous trees, season of pruning, 3695.
- Resins, what, from what plants obtained, and how used, 1427; rosin, 1428; pitch and tar, 1429; mastick, 1430; sandarach, 1431; elemi, 1432; tacambac, 1433; labdanum, 1434; opobalsamum, or balm of Gilead, 1435; copaiva, 1436; dragon's blood, 1437; guaiac, 1438; Botany Bay resin, 1439; green resin, 1440; copal, 1441; animé, 1442; lac, 1443; bloom, 1444; use of resins, 1445; gum resins, 1446.
- Retiring houses of China, 999.
- Rhomboidal harrow, 2571.
- Rhubarb, 5518.
- Ribwort plantain, culture of, 5070.
- Ricci, Jacopo, his works on agriculture, page 1178. A. D. 1816.
- Rice, its culture, 4735.
- Rice, culture of, in Egypt, 1052.
- Rice in Hindustan, 881.
- Richards, John, his work on stewards and tenants, page 1164. A. D. 1730.
- Richter, K. F., his work on agriculture, page 1176. A. D. 1804.
- Ricinus communis (figured), the castor oil plant, 849; cultivated by the Chinese, 970.
- Rick yard, 2744.
- Ridging, 2891.
- Riem, his work on agriculture, page 1172. A. D. 1770.
- Riem, J., his work on agriculture, page 1176. A. D. 1792.
- Rigaud, de l' Isle, his work on agriculture, page 1172. A. D. 1769.
- Rigby, Edward, M.D. F.L.S., his work on agriculture, page 1170. A. D. 1820.
- Ring bone, 5840.
- Ringsted, Josiah, Esq., his works on agriculture, page 1165. A. D. 1774.
- Rippling, 2066.
- Rising of the lights in sheep, 6508.
- Rivers, to change their course, 4045.
- Rivers, guarding of their banks, 4038.
- Rizhaub, his work on agriculture, page 1176. A. D. 1786.
- Road, one on an inclined plane near Warrington, 7027.
- Roads, concave, in Derbyshire, 7014.
- Roads of Sutherland, 7070.
- Roads, their different kinds, 3286; national or highways, 3287; parochial, 3288; lanes, 3289; estate roads, 3290; farm roads, 3291; horse roads, 3292; foot paths, 3293; railroads, 3294; paved roads, 3295; planked roads, 3296; approach roads, 3297.
- Roads, their formation, 3280; kinds, 3286; direction, or laying out of roads, 3299; form and materials, 3317; wear or injury of roads, 3318; M<sup>r</sup> Adam's theory, 3333; paved roads, 3439; railroads, 3459; preservation and repair, 3473.
- Roads, origin of their improvement in Scotland, 750.
- Roads of Java, 937.
- Roaring, or pneumonia, 5787.
- Robertson, James, D. D., his work on agriculture, page 1168. A. D. 1799.
- Robertson, Rev. George, his work on agriculture, page 1167. A. D. 1795.
- Robson, James, his work on agriculture, page 1167. A. D. 1794.
- Rocca, Abbé Della, his work on bees, page 1177. A. D. 1790.
- Rocks, how converted into soils, 2061.
- Rocky surfaces, to improve, 4163.
- Rocque, Bartholomew, his works on agriculture, page 1164. A. D. 1761.
- Roe deer, *C. capreolus*, 6618.
- Rollers, 2578; common, 2579; parted cast iron roller, 2580; spiky, 2581; roller and water box, 2582; furrow roller, 2583; Norfolk drilling roller, 2584; pressing plough or roller, 2585.
- Rolling, 3028; grass lands, 3029.
- Roman agriculture, profits of, 166.
- Roman agricultural writers, 44.
- Roman agriculture as a science, 170; its extent in other countries, 174; in Germany, 175; in Britain, 176; its decline, 178.
- Roman farmers, 60.
- Roman plough, 110.
- Roman ploughmen, their qualities, 88.
- Roman servants, 88; their wages, 89; their food, 91.
- Romans, landed property among, 53.
- Romans, their agriculture, 42.
- Romans, their villas, 75.
- Romans, their maxims of farm management, 157.
- Romans, their farms and farmeries, 72.
- Romans, their farm management, 71.
- Romans, their agricultural implements, 109.
- Romans, their agricultural operations, 126; ploughing, 127; following, 128; manuring, 129; sowing, 131; reaping, 132; threshing, 135; hay making, 138; weeding, 139; harrowing, 140; watering, 141.
- Romans, their agricultural animals, 93; bulls, 95; cows, 96; oxen, 101; asses, 105; mules, 106; horses, 107; dog, 108; sheep, 108.
- Romans, their beasts of labor, 93.
- Ronconi, Ignazio, his work on agriculture, page 1177. A. D. 1804.
- Rood's convertible waggon, 2624.
- Root breaker or bruiser, 2474.
- Root house, 2704.
- Rope twister, 2396.
- Rope twisting machine, 2457.
- Rope twisting, 2947.
- Roscommon, agricultural survey of, 7094.
- Rosin, from what plants obtained, and how manufactured and used, 1428.
- Ross, Nairn, and Cromarty, agricultural survey of the shires of, 7063.
- Rossig, Karl Glo, his work on agriculture, page 1176. A. D. 1781.
- Rossore, agricultural establishment of, in Tuscany, 297.
- Rot in sheep, 6502. 6518.
- Rotation of crops, theory of its beneficial effects, 2154; by Sir H. Davy, 2155; by Yvart and Picquet, 2158; influence in destroying insects by Olivier, 2160.
- Rotation of crops in Saxony, 599.
- Rotations of crops in Lombardy, 272; in Tuscany, 282.

- Rotations of crops, 4549; see Crops.  
 Rotations of crops in Flanders, 445.  
 Rotations of crops in Spain, 712.  
*Roughley*, Thomas, his work on agriculture, page 1179. A. D. 1823.  
 Row culture of China, 1002.  
 Bowels, 5869.  
 Roxburghshire, agricultural survey of, 7050.  
*Rozier*, Francois, his work on agriculture, page 1172. A. D. 1772.  
 Rubbers or ray in sheep, 6522.  
*Rubus chamæmorus* (figured), cloudberry, 680.  
*Ruckert*, G. Ch. Alb., his work on agriculture, page 1176. A. D. 1800.  
*Rudge*, Rev. Thomas, B.D., his work on agriculture, page 1169. A. D. 1807.  
 Running thrush in the feet of horses, 5855.  
 Runners of plants, to propagate by, 1617.  
 Russia, agriculture of, 645; climate, 647; landed property, 653; farmeries, 654; villages, 654; agricultural products, 655; fruits, 659; live stock, 660; forests, 661; implements and operations, 662.  
 Rutlandshire, agricultural survey of, 7017.  
 Rye, culture of, 4650.  
 Rye, culture of, in Flanders, 455.  
*Rye*, George, his work on agriculture, page 1164. A. D. 1780.
- S.
- Sack barrow, 2450.  
 Saffron, 5511.  
 St. Helena, agriculture of, 1118.  
 Saintfoin, culture of, 5042; soil, 5044; sowing, 5047; taking the crop, 5052; produce, 5055.  
*Salisbury*, W., his work on agriculture, page 1170. A. D. 1822.  
 Salivation in horses, 5793.  
 Salmon, natural history of, by *Headrick*, 7064.  
 Salmon, 6811.  
 Salmon fishery, 3605.  
 Salmon fishery of the Tyne, 7023; of the Tweed, 7024.  
*Salmon*, William, M.D., his work on agriculture, page 1163. A. D. 1723.  
 Salop, from what plants obtained and how manufactured, 1375.  
 Salt, use of, in Cornwall, 7039.  
 Salt mines of Cheshire, 7028.  
 Salt works of Droitwich, 7007.  
 Salt mines, 3592.  
 Salt works of Moutiers, 370.  
 Salting hay, 5233.  
 Salts, as ingredients of vegetable food, 1504.  
*Salvini*, Gio., his work on agriculture, page 1177. A. D. 1163.  
 Samnite plough, 682.  
*Sampson*, Rev. G. Vaughan, his work on agriculture, page 1168. A. D. 1802.  
 Sand cracks in the feet of horses, 5856.  
 Sandwich Isles, agriculture of, 1034.  
 Sap, ascent of, in plants, 1513.  
 Sap of plants, what, and how obtained, 1469.  
*Sarcey*, de Sütieres, his works on agriculture, page 1172. A. D. 1765.  
 Sark, agricultural survey of, 7040.  
 Savoy, agriculture of, 347.  
 Savoy, peasantry of, 350; occupation of land, 352; leases, 357; pasturage, 358; public dairies, 359; vineyards, 361; walnut trees, 362; tobacco, 366; salt works of Moutiers, 370.  
 Saw fly, 6902.  
 Sawing, 2914.  
 Saxony, agriculture of, 596; culture of the vine and silkworm, 597; sheep, 598; rotation of crops, 599; cows, 600.  
 Scab in sheep, 6522.  
 Scalding mixture for the pole-evil in horses, 5917.  
 Scarifiers, 2527.  
*Scheffold*, L., his work on agriculture, page 1176. A. D. 1809.  
*Schönleutner*, M., his work on agriculture, page 1176. A. D. 1810.  
 Scientific operations required of the agriculturist, 3053.  
*Scirpus tuberosus* (figured), its culture in China, 978.  
 Scotch farmers in Wiltshire, 7032.  
 Scotch or Small's plough (figured), 770.  
 Scotch cart (figured), 770.  
 Scotch plough with two wheels, 2507; with one wheel, 2508.  
 Scotch scarifier, cultivator or grubber, 2533.  
 Scotch horse hoe, 2540.  
 Scotland, agriculture in, during the sixteenth century, 226, 241.  
 Scotland, agriculture of, from the eleventh to the thirteenth century, 208.  
 Scots grass, *Panicum hirtellum* (figured), 1186.  
 Scott, W., his law book relative to agriculture, page 1168. A. D. 1801.  
 Scott, Edmund, his work on agriculture, page 1163. A. D. 1801.  
 Scour in sheep, 6515.  
 Scouring in sheep, 6516.  
 Scouring or diarrhoea in horned cattle, 6266.  
 Scraper, 2392.  
 Scraping, 2897.  
 Screening or sifting, 2899.  
 Scuttle, the name of a shallow basket or sort of wicker bowl much used in the barn and for other purposes. The large ones have handles, but the small ones are without them.  
 Scythe, Hainault, or Flanders, 502.  
 Scythe, Brabant, 503.  
 Scythe, cradle, of France, 398.  
 Scythes, 2403; Hainault scythe, 2404; cradle scythe, 2405.  
 Sea-weed eaten in Cochin China, 944.  
 Sea-weed, or kelp, its growth and manufacture, 5529.  
 Sea-weeds, theory of their operation as a manure, 2174.  
*Sebright*, Sir J. S., his theory of improving the breed of animals, 1995.  
 Seed basket, 2437.  
 Seed, its impregnation, 1592; hybrids, 1598; crossing, 1599.  
 Seeds of plants, their germination, 1486; physical phenomena, 1493; chemical phenomena, 1494.  
 Selkirkshire, agricultural survey of, 7051.  
 Sellenders and mallenders, 5836.  
 September, weather, and agricultural operations to be performed in, page 1194.  
 Servants, their management, 4522.  
 Servants of the Romans, 85; their wages, 89; food, 91.  
*Servieres*, B. de, his work on agriculture, page 1173. A. D. 1786.  
 Sesamum orientale, cultivated by the Chinese, 970.  
 Sesamum orientale (figured), cultivated as an oil plant by the Romans, 150.  
 Setons, 5868.  
 Shab or scab in sheep, 6522.  
 Shaddocks of Madeira (figured), 1126.  
 Shear hog, a wether lamb in his second year, 6413.  
 Shearing of sheep, 6436.  
 Sheep, 6381; varieties, 6384; criteria, 6410; breeding, 6414; rearing, 6429; folding, 6468; fattening, 6478; merinos, 6489; anatomy and physiology of sheep, 6497; diseases, 6501.  
 Sheep of North Wales, 7044.  
 Sheep, Wiltshire, 7032; of Dorsetshire, 7033.  
 Sheep, how treated in France, 391.  
 Sheep of Hindustan, 900.  
 Sheep of the Cape of Good Hope, 1101.  
 Sheep (merino) of Spain, their management, 714.  
 Sheep tax, 6913.  
 Shifts, such parts of a farm as are allotted for the reception of either stock or crops. It is also a term applied to the rotations of cropping lands; thus, we have three, four, five and six coarse shifts, 4549.  
*Shirreff*, John, his works on agriculture, page 1170. A. D. 1814.  
 Ship timber, how to produce bends for, 3700.  
 Shoe, improved form of, for horses, 5926; bar shoe, 5932; hunting shoe, 5933; racing shoe, 5934; grass shoe, 5935; frost shoe, 5936; calkins, 5937; horse pattens, 5938.  
 Shoeing and shoes for horses, various methods and kinds, 5925.  
 Shoeing of oxen, 6219.  
 Shoeing of horses, 5925; improved mode, 5926; various modes, 5927, 5932.  
 Short horned or Dutch cattle, 6109.  
 Shoulder strains in horses, 5828.  
 Shovel, 2377.  
 Shovelling, 2888.  
 Shropshire, agricultural survey of, 7010.  
 Siam, agriculture of, 939.



- Sickler*, F. Ch. L., his work on agriculture, page 1176. A. D. 1805.
- Siddow pease, *i. e.* such as boil freely, 7006.
- Sidera Hall farm, 3855.
- Sierra Leone (mountains of the lions), agriculture of, 1079.
- Sieves, 2434.
- Sieuew*, his works on agriculture, page 1172. A. D. 1769.
- Sifting or screening, 2899.
- Silk worm or moth, 6822; treatment of the mulberry, 6824; produce of the worms, 6825; culture of silk in England, 6826.
- Silk worms in China, 985.
- Silk worm, culture of in Austria, 617.
- Silk worm, its culture in Hindustan, 884.
- Silk worm, its culture in Spain, 709.
- Simonde*, J. C. L., his work on agriculture, page 1177. A. D. 1801.
- Simpson*, Pindar, his treatise on the mangel-wurzel, page 1170. A. D. 1815.
- Sinclair*, G., F.L.S., F.H.S., his work on agriculture, page 1171. A. D. 1824.
- Sinclair*, Rt. Hon. Sir John, Bart., LL.D., M.P., his works on agriculture, page 1166. A. D. 1790.
- Sinety*, André Louis, Esprit, his work on agriculture, page 1174. A. D. 1803.
- Singer*, Rev. William, D.D., his work on agriculture, page 1170. A. D. 1812.
- Singing birds, 6792; breeding and rearing, 6794; aviary, 6795.
- Single hoe plough, 2502.
- Skeleton of the sheep, 6498.
- Skim milk, 6378.
- Skin, diseases of, in horses, 5818.
- Slaney*, Robert A., Esq., his work on agriculture, page 1171. A. D. 1824.
- Slaughtering animals, physiologically considered, 2048.
- Slide for conveying mountain timber, 339.
- Sligo, agricultural survey of, 7098.
- Slimy flux, see Dysentery, 6267.
- Slips of plants, to propagate by, 1618.
- Slugs, to destroy, 6922.
- Sluice, 4075.
- Small*, James, his treatise on ploughs, &c., page 1166. A. D. 1784.
- Small's plough (figured), 770.
- Smith*, Rev. John, D.D., his work on agriculture, page 1167. A. D. 1798.
- Smith* or *Smyth*, John, his work on agriculture, page 1163. A. D. 1670.
- Smith*, William, his works on irrigation, page 1169. A. D. 1806.
- Smith*, Rev. Samuel, his work on agriculture, page 1170. A. D. 1811.
- Smut, a disease of plants, 1658.
- Smut machine, 2648.
- Snail, edible, 6843.
- Snails and slugs, to destroy, 6922.
- Snow, its influence in retaining heat, 2257.
- Snow, theory of, 2309.
- Soaper's waste, its theory as a manure, 2243.
- Social habit of plants, its influence on their distribution, 1736.
- Society of improvers in Scotland, their history, 775.
- Soderini*, Giovanvettorio, e Bernardo Davazati, their works on agriculture, page 1177. A. D. 1622.
- Soil borer, 2428; of peat, 2430; draining auger, 2431.
- Soiling with clover, 5004.
- Soils, see Earths and Soils, 2054.
- Soils, their influence on the distribution of vegetables, 1711.
- Soils, their improvement by incineration or burning, 2184.
- Soils, their aeration or fallowing, 2124.
- Soils, influence of the weather on, 2150; solar influence, 2151; shelter, 2152; shade, 2153.
- Soils, how to discover by chemical analysis, 2083.
- Soils of bad quality, 2099.
- Soils, their use to vegetables, 2095.
- Soils, influence of color on, 2108.
- Soils, their pulverization, 2113.
- Soils, how to discover their qualities mechanically, 2087.
- Soils of excellent quality, 2104; at Ormiston, at Mersea, 2104.
- Solar rays, their influence on vegetation, 2259.
- Solomon Isles, agriculture of, 1027.
- Somersetshire, agricultural survey of, 7034; North-east district, 7035; Middle district, 7036; South-east district, 7037.
- Somerville*, Right Hon. John, Lord, his works on agriculture, page 1168. A. D. 1799.
- Somerville*, Robert, his work on agriculture, page 1169. A. D. 1805.
- Somerville plough, 2492.
- Soot, as a manure, 2204.
- Soot, theory of its operation as a manure, 2242.
- Sore throat, 5781.
- Sour cream, 6372.
- South America, agriculture of, 1201; Terra Firma, 1202; Peru, 1203; Chili, 1204; Paraguay, 1206; Brazil, 1207; Cayenne, 1215; Surinam, 1216; Amazonia, 1218; Patagonia, 1219.
- South American islands, agriculture of, 1220.
- Sowing, 2912; broadcast, 2913.
- Sowing among the Romans, 131.
- Sowing of plantations considered, 3645.
- Spade, 2376.
- Spade of the Bushmans of Africa, 1113.
- Spadon*, Paolo, his works on agriculture, page 1178. A. D. 1810.
- Spain, agriculture of, 688; Moors, 689; sugar-canes of the Moors, 690; climate, 695; surface, 696; soil, 697; landed property, 698; agricultural products, 700; olive, 706; vine, 707; sugar-cane, 708; cotton, 711; rotations of crops, 712; live stock, 713; merino sheep, 714; agricultural implements, 723; operations, 724; forests, 726.
- Spanish or Merino sheep, 6407.
- Spaying, the operation of castrating the females of different kinds of animals, as sows, heifers, mares, &c. in order to prevent any future conception, and promote their fattening. It is performed by cutting them in the mid flank, on the left side, with a sharp knife or lancet, in order to extirpate or cut off the parts destined for conception, and then stitching up the wound, anointing the part with tar salve, keeping the animal warm for two or three days. The usual way is to make the incision in a sloping manner, two inches and a half long, that the fore-finger may be put in towards the back, to feel for the ovaries, which are two kernels as big as acorns, one on each side of the uterus, one of which being drawn to the wound, the cord or string is cut, and thus both taken out, 6162.
- Speed*, Adam, his works on agriculture, page 1162. A. D. 1626.
- Spergula arvensis* (figured), spurry, 475.
- Sphynxes or hawk moths, 6894.
- Spider, common, 6914; red spider, 6913.
- Spilts and bone spavins, 5838.
- Splitting, 2921.
- Spring fly, 6899.
- Springs, to collect, 4128.
- Spurry, culture of, 5079.
- Spurry (figured), *Spergula arvensis*, culture of, in Flanders, 475.
- Stable, 2662; farm stables in Scotland, 2667; horse hammels, 2675.
- Stacey*, Rev. Henry Peter, LL.B., F.L.S., his work on agriculture, page 1168. A. D. 1800.
- Stack borer, 2412.
- Stack covers, 2750.
- Stack funnels, 2749.
- Stack guard or cover (figured), 3047.
- Stack stands of stone and iron, 2747.
- Stack yard, 2744.
- Stacking stage, 3048.
- Stacking hay, 3044; hay stacks of Middlesex, 3046.
- Stacking wood for fuel, 2969.
- Stacking corn, 3035; rules, 3036; unsheaved corn, 3041; sheaved corn, 3042.
- Stafford*, Marquess of, his improvements in Shropshire, 7010.
- Stafford*, Marquess of, his improvements in Sutherland, 7070.
- Staffordshire, agricultural survey of, 7011.
- Stag deer, Cervus elephas, 6617.
- Staggers in horses, 5761.
- Staggers, daisy, or turning in cattle, 6270.
- Staggers, gid, or turnsick in sheep, 6524.
- Stair*, Earl of, an active improver, 775.
- Stands for corn, 2745; for hay, 2748.
- Starch, from what plants obtained, and how manufactured, 1374, 1375; uses, &c., 1376, 1377.
- Statistics of British agriculture, 6923.

- Steaming machines, 2651; steamers on a grand scale, 2652; economical steaming and washing machines, 2653, 2654; boiling machines, 2655; baking ovens, 2656.
- Steaming house, 2705.
- Steel-yard, 2465.
- Steindel*, A. H. Von, his work on agriculture, page 1176. A. D. 1800.
- Stevenson*, W., Esq., his work on agriculture, page 1169. A. D. 1809.
- Steward, see Manager.
- Stillingfleet*, Benjamin, his works on agriculture, page 1164. A. D. 1759.
- Stipa tenacissima, the esparto rush, 701.
- Stirlingshire, agricultural survey of, 7058.
- Stirring with the grubber and other pronged implements, 3019.
- Stirring the soil among the Romans, 139.
- Stocking of farms; see Farms.
- Stomach staggers, 5795.
- Stomach, inflammation of, in sheep, 6510.
- Stone*, Thomas, his works on agriculture, page 1166. A. D. 1785.
- Stone and gravel in horses, 5817.
- Stone walls, different sorts of, 2831; see Fences.
- Store sheep husbandry, 6450.
- Strain in the shoulders of horses, 5828; in the whirlbone, 5830; in the stifle, 5832; in the back sinews, 5833; of the leg, 5834; of the fetlock and coffin joints, 5835.
- Strangeholes*, Samuel, his work on agriculture, page 1163. A. D. 1663.
- Strangles, vives, or vives, 5774.
- Strangury, or suppression of urine, 5815.
- Strata of England (figured), 2056.
- Straw, to truss, 2951.
- Straw rope making, 2947.
- Straw plait, best grasses for, 5193.
- Straw house, 2706.
- Straw-yard, 2751.
- Strawberries, culture of, in Midlothian, 7047.
- Strickland*, H., Esq., his work on agriculture, page 1170. A. D. 1812.
- Stud and mud, houses built of frame work filled in with clay and straw mixed instead of brick-work, 7038.
- Stumpf*, G., his work on agriculture, page 1176. A. D. 1794.
- Sturdy in horses, 5799.
- Sturdy in sheep, 6524.
- Styles, 2870; see Gates.
- Substances obtained from plants; see Vegetable Products.
- Subterraneous irrigation, 4124.
- Suckers of plants, to propagate by, 1620.
- Suckow*, G. Adf. his work on agriculture, page 1176. A. D. 1775.
- Suffolk, agricultural survey of, 7002.
- Suffolk cattle, 6117.
- Sugar and indigo, attempt to cultivate in Italy, 58.
- Sugar cane, culture of, by the ancient Moors, 690.
- Sugar cane, its culture in Spain, 708.
- Sugar cane, its culture in Egypt, 1056.
- Sugar cane, culture of, in Jamaica, 1187.
- Sugar cane, its culture and manufacture in Hindustan, 882.
- Sugar, from what plants obtained, and how manufactured, 1372; different uses of sugar, 1373.
- Sugar from beet root, manufacture of, in Flanders, 470.
- Sugar plants of Austria, 617.
- Sumatra, agriculture of, 103.
- Sun flower, its culture as an oil plant, 5477.
- Surfaces, preparation of, for irrigation, 4096.
- Surfeit in horses, 5818.
- Surgery in cattle, 6272.
- Surinam, agriculture of, 1216; principal products, 1217.
- Surrey, agricultural survey of, 6993.
- Sussex and Herefordshire cattle, 6114.
- Sussex, agricultural survey of, 6994.
- Sutherland, agricultural survey of, 7070.
- Swan, Anas olor, 6752; varieties or species, 6753; rearing, 6754; feathers and down, 6755.
- Swayne*, G., his work on grasses, page 1166. A. D. 1790.
- Sweden and Norway, agriculture of, 665; climate, 666; surface, 667; soil, 669; landed property, 670; cottages, 671; agricultural produce, 674; war, 678; berries, 680; live stock, 681; implements and operations, 682; harvesting, 683.
- Sweeping, 2398.
- Swelled neck, 5782.
- Swinbourne*, R., his farmer's account book, page 1170. A. D. 1819.
- Swine, 6530; varieties, 6538; breeding and rearing, 6561; fattening, 6570; curing pork and bacon, 6576; diseases, 6581.
- Swine of France, 396.
- Swine, mode of breeding and rearing in Mexico, 1163.
- Swine of Paraguay (figured), 1207.
- Swine of Hindustan, 902.
- Swine, wild, Lady Salisbury's breed of, 6997.
- Swing ploughs, 2479.
- Swiss cantons, present state of agriculture in, 327.
- Switzer*, Stephen, his work on agriculture, page 1163. A. D. 1718.
- Switzerland, state of landed property in, 328.
- Switzerland, agriculture of, its present state, 326.
- Syrian goat, 6584.
- Systematic botany, study of, 1266; glossology, 1266; phytography, 1269; taxonomy, 1275.

## T.

- Tagbelt in sheep, 6517.
- Tag sheep; see Hog sheep.
- Tanners' spent bark, how to convert to manure, 2178.
- Tannin, from what plants obtained, and in what proportions, 1393; its utility, 1394.
- Tar, from what plants obtained, and how manufactured and used, 1429.
- Tare, its culture, 4795; varieties, 4796; soil, 4799; sowing, 4801; reaping, 4806; produce, 4809; application, 4811.
- Tarello*, Camillo, his works on agriculture, page 1177. A. D. 1772.
- Targioni*, Tozzetti, his works on agriculture, page 1178. A. D. 1809.
- Targioni*, Luigi, his works on agriculture, page 1177. A. D. 1802.
- Tatham*, William, his works on agriculture, page 1168. A. D. 1798.
- Taxonomy, or the classification of plants, 1275.
- Tea plant, culture of, in China, 961; gathering the leaves, 962; various species grown as tea plants, 962; curing and sorting the leaves, 963; sorts of black and green tea, 964; select sorts of tea, 965; Chinese substitutes for tea, 966.
- Tea districts of China, 960.
- Teazle, or fuller's thistle, its culture, 5339.
- Teeth, diseases of, 5636, 5779.
- Teeth of horses, as indicative of age, 5956.
- Temperature, its influence on the distribution of vegetables, 1690.
- Tench, 6803.
- Tenures of landed property, 3144; in England, 3145; Scotland, 3157; Ireland, 3163.
- Terra Firma, agriculture of, 1202.
- Territorial property, its kinds and tenures, 3144; its valuation, 3165.
- Tessier*, Henri Alexandre, his works on agriculture, page 1173. A. D. 1791.
- Tetanus, or locked jaw in horses, 5763.
- Tetanus, or locked jaw in cattle, 6271.
- Thaer*, Alb. his works on agriculture, page 1176. A. D. 1798.
- Thaive, a ewe in the second year, 6413.
- Thatching, 2948; with straw, 2949; stubble, 2950; reed, 2953.
- Thatching knife, 2411.
- The Hebrides, agricultural survey of, 7073.
- The fox, 6848; mole, 6854; mouse, 6859; rat, 6855; polecat, 6851; weasel, 6852; badger, 6853.
- Theress*, Theodore, his work on agriculture, page 1176. A. D. 1808.
- Thessaly and Albania, agriculture of, 736.
- Thibet, agriculture of, 1006.
- Thick wind, or pneumonia, 5786.
- Thierat*, his work on agriculture, page 1172. A. D. 1763.
- Thiery*, P. J., his work on agriculture, page 1175. A. D. 1822.
- Thinning, 2905.
- Thirlstane store farm, 6451.
- Thistle hoe, or hoe scythe, 2549.
- Thistle pincers, 2394.
- Thompson*, Robert, his work on agriculture, page 1168. A. D. 1802.

- Thomson*, Rev. John, D.D., his work on agriculture, page 1168. A. D. 1800.
- Thoroughpin or blood spavin, 5841.
- Thouin*, M. André, le Chevalier de, his work on agriculture, page 1174. A. D. 1812.
- Thread and dying plants, substitutes for, 5389.
- Three wheeled cart, 2618.
- Threshing machines, history of, 2625; machine by Menzies, 2627; Dumblane, 2628; Elderton, Smart, 2629; Meikle, 2630; improvements on the threshing machine of Meikle, 2631; mode of yoking, 2632; winning machines, 2633; advantages of threshing machines, 2634; Meikle's two horse machine, 2638; Meikle's water threshing machine, 2640; Meikle's machine for water or horses, 2641; Meikle's machine for wind or horses, 2642; Meikle's machine for steam, 2643; portable machines, 2644; Weir's two horse power portable machine, 2645; machines by Lester on the rubbing principle, 2646; by Forrest, on the rubbing and scutching principle combined, 2647.
- Threshing machine, Meikle's, in Hertfordshire, 6997.
- Threshing by the flail, 2961; whipping out, 2965.
- Threshing among the Carthaginians, 136.
- Threshing machine, history of its introduction, 777.
- Threshing among the Romans, 135.
- Threshing machine for a manual power, 2453.
- Threshing mill barns, 2697.
- Threshing floors, to form, 2691.
- Throat, diseases of the, 5781.
- Thunder, theory of, 2322.
- Tibbs*, Thomas, his work on agriculture, page 1169. A. D. 1808.
- Tighe*, William, his work on agriculture, page 1168. A. D. 1802.
- Tillage implements, 2478.
- Tillage of China, 989.
- Tillet*, du, his work on agriculture, page 1171. A. D. 1755.
- Timber, its conveyance in Switzerland by a mountain slide, 339; by floating, 340.
- Timber, its valuation, 3763; disposal by sale, 3769; price, 3768.
- Time book, form of, 3140.
- Tipperary, agricultural survey of, 7090.
- Tithes in Ireland, 836.
- Tobacco, its culture in Hindustan, 886.
- Tobacco, its culture at the Cape, 1098.
- Tobacco, its culture and manufacture, 5505.
- Tobacco, culture of, in Yorkshire, 7021.
- Tobacco, culture of, in Roxburghshire, 7050.
- Tollard*, Claude, his work on agriculture, page 1174. A. D. 1805.
- Tonquin, agriculture of, 945.
- Tool house, 2708.
- Topographical survey of agriculture in Britain, 6989; (see the different counties.)
- Tortpidity of animals, 1974.
- Tortoise, common, 6819; mud tortoise, 6820.
- Tortoise of Hungary, 624.
- Towne*, L., his Farmer's Guide, page 1170. A. D. 1820.
- Townsend*, Rev. Horatio, M.A., his work on agriculture, page 1170. A. D. 1810.
- Tradesman's yard in the farmery, 2753.
- Training of horses, 5984.
- Tramel, an instrument or device, made sometimes of leather, but more usually of ropes, fitted to the legs of horses to regulate their motion, and teach them to amble, 5997.
- Traps for vermin, 2475.
- Tratmann*, Cp., his work on agriculture, page 1176. A. D. 1809.
- Treads or over-reach on the feet of horses, 5859.
- Trees, their products, how used or disposed of, 3734.
- Trees, table of, for different soils, 3639.
- Trees, diseased or injured, their treatment, 3724.
- Trees, management of, by the Romans, 145.
- Trees, leaves of, used as fodder for cattle in France, 492.
- Trees, their importance to a landed estate, 3627.
- Trench in irrigation, 4081.
- Trench drain in irrigation, 4082.
- Trenching, 2890.
- Trenching or mining plough, 2497.
- Trenching plough, 2497.
- Trentham estates, improvements on, 7011; charities at, 7011.
- Trifolium Alexandrinum, the clover of Egypt, 1051.
- Tripoli, agriculture of, 1067.
- Trother*, his work on agriculture, page 1173. A. D. 1773.
- Trotter*, James, his work on agriculture, page 1170. A. D. 1812.
- Trotting of horses, 5991.
- Trout, 6811.
- Trowel*, Samuel, his work on agriculture, page 1164. A. D. 1739.
- Truffle, *Tuber cibarium* (figured), of Hungary, 1310.
- Trunk, in irrigation, 4076.
- Truster*, Rev. John, LL.D., his works on agriculture, page 1166. A. D. 1780.
- Trussing hay or straw, 2950.
- Tuke*, John, his work on agriculture, page 1168. A. D. 1800.
- Tull*, Jethro, his work on agriculture, page 1164. A. D. 1731.
- Tull's system of culture, history of, 756.
- Tunis, agriculture of, 1068.
- Tupputi*, D., his work on agriculture, page 1178. A. D. 1808.
- Turbilly*, Louis Francois Henri de Menon, Marquis de, his works on agriculture, page 1172. A. D. 1760.
- Turf spade, 2378.
- Turkey, *Meleagris gallinavo*, 6724; varieties, 6725; breeding, 6726; fattening, 6728; feathers, 6729.
- Turkies, American, 7014.
- Turn of water in irrigation, 4089.
- Turner*, Nicholas, his essay on draining, page 1166. A. D. 1784.
- Turning or stagers in cattle, 6270.
- Turnip, its culture, 4876; varieties, 4878; soil, 4885; sowing, 4889; summary of turnip culture, 4894; taking the crop and applying it, 4895; produce, 4907; to raise seed, 4909; diseases, 4913.
- Turnip, history of, in Northumberland, 7024.
- Turnip chopper, 2456.
- Turnip drills, 2555.
- Turnip roller, 2473.
- Turnip tray, 2440.
- Turnip hoeing, 3024.
- Turnip, culture of, in Flanders, 464.
- Turnip barrow drill, 2472.
- Turnip slicer, 2455.
- Turnips and clover, their introduction as agricultural plants in England, 235.
- Turnips, their introduction to Surrey, 6993.
- Turnsick or sturdy, 6769.
- Turnsick in sheep, 6524.
- Turn-wrest swing plough, 4493.
- Tusser*, Thomas, his works on agriculture, page 1166. A. D. 1557.
- Tweeddale, agricultural survey of, 7052.
- Tyrone, agricultural survey of, 7102.

## U.

- United States, agriculture of, 1130; climate, 1130; season, 1131; surface, 1132; soil, 1133; landed property, 1134; dividing and selling lands, 1135; price, 1136; lands not yet cultivated, 1138; practice of new settlers, 1139; political circumstances, 1141; agricultural products, 1142; live stock, 1143; operations, 1144; civil circumstances, 1146; domestics, 1147; emigration, 1148.
- United States as compared with Van Diemen's land, 1149.
- Upas, or poison tree of Java, 936.
- Urinary, 2743.
- Urinary organs of horses, diseases of, 5812.
- Urine, bloody, or strangury, 5815.
- Urine, cisterns of, Flemish farmeries, 434.
- Urine, incontinence of, 5815.
- Urine drink used in veterinary practice, 5905.
- Urine, suppression of, 5815.
- Urine, theory of its operation as a manure, 2191.

## V.

- Valerian, 5525.
- Valerian, culture of, in Derbyshire, 7014.
- Valisneria spiralis, singular economy of, 1591.
- Vallée*, Alexandre, his work on agriculture, page 1177. A. D. 1803.
- Valuation of trees and plantations, 3089. 3763.
- Valuation, purchase, and transfer of landed property, 3143.
- Valuing labor and materials, 3083; farming stock,

- 3086; leases, 3094; landed property, 3099; mines and minerals, 3105.
- Vancouver*, Charles, his work on agriculture, page 1169. A. D. 1807.
- Vanderstraten*, F., his work on agriculture, page 1170. A. D. 1816.
- Van Diemen's land, agriculture of, 1029.
- Van Diemen's land as compared with the United States, 1149.
- Varenne de Feuille*, P. C., his works on agriculture, page 1173. A. D. 1789.
- Varlo*, C., Esq., his work on agriculture, page 1165. A. D. 1774.
- Varro*, M. Terentius, his works on agriculture, 46.
- Vegetable anatomy, 1278; external structure, 1279; internal structure, 1311.
- Vegetable chemistry, 1365; compound products, 1369; simple products, 1484.
- Vegetable culture as derived from the study of the nature of vegetables, 1786.
- Vegetable geography and history, 1687; geographical distribution, 1688; physical distribution, 1689; civil distribution, 1727; picturesque distribution, 1736; systematic distribution, 1740; economical distribution, 1747; arithmetical distribution, 1758; distribution of the British flora, 1759.
- Vegetable kingdom, study of, with a view to agriculture, 1264; systematic botany, 1266; vegetable anatomy, 1278; vegetable chemistry, 1365; functions of vegetables, 1485; vegetable pathology, 1638; vegetable geography and history, 1687; principles of vegetable culture, 1786.
- Vegetable life, its character, 1623; counteraction of chemical affinity, 1623; excitability, 1624.
- Vegetable nutrition, 1511; introsusception, 1512; ascent of the sap, 1513; motion of the sap, 1514; elaboration of the sap, 1523; descent of the sap when elaborated into proper juice, 1533.
- Vegetable oils, 1407; fixed oils, 1408; fat oils, 1409; drying oils, 1414; volatile oils, 1419.
- Vegetable physiology, or the functions of plants, 1485; germination of the seed, 1486; food of the vegetating plant, 1495; process of nutrition, 1511; development or growth, 1537; sexuality, 1589; impregnation of the seed, 1592; propagation of the species, 1606; checks to propagation, 1622; character of vegetable life, 1623.
- Vegetable products, 1369; gum, 1369; sugar, 1372; starch, 1374; salop, 1375; gluten, 1378; albumen, 1318; fibrina, 1381; extract, 1382; coloring matter, 1388; tannin, 1393; bitter principle, 1395; narcotic principle, 1396; acids, 1397; oils, 1407; wax, 1420; resin, 1427; rosin, 1428; pitch and tar, 1429; gum resins, 1446; myrrh, 1455; assa-fetida, 1456; balsams, 1457; camphor, 1463; caoutchouc, or India rubber, 1464; cork, 1465; wood, 1466; charcoal, 1468; sap, 1469; juices, 1470; virtues, 1471; ashes, 1472; alkalies, 1474; earths, 1476; other substances, 1483.
- Vegetable poisons, 5794.
- Vegetables employed in human economy, their distribution, 1747; bread corns, 1748; edible roots, 1749; oleaceous herbs, 1750; fruits, 1751; fruits of the East Indies, 1752; of China, 1753; of Africa, 1753; of South America, 1754; flowers, 1756; timber, 1757.
- Vegetables of various kinds cultivated in China, 981.
- Vegetables, their systematic distribution, 1740; plants of visible sexes, 1741; sexual parts indistinct, 1742; monocotyledonæ, 1743; dicotyledonæ, 1744; natural orders of Jussieu, 1745; universal plants, 1746.
- Vegetables, their natural decay or death, 1681; temporary organs, 1682; leaves, 1683; flowers, 1684; fruit, 1685; permanent organs, 1686.
- Vegetables, their diseases and casualties, 1638; wounds and accidents, 1639; diseases, 1652; natural decay, 1681.
- Vegetables, principles of preserving for future use, 1797.
- Vegetables, their propagation, 1606; by seeds, 1608; by gems, 1613; bulbs, 1614; buds, 1615; leaves, 1616; runners, 1617; slips, 1618; layers, 1619; suckers, 1620; grafting and budding, 1621; causes limiting propagation, 1622.
- Vegetables, their growth or development of parts, 1537; elementary organs, 1538; composite organs, 1540; annual shoots, 1541; root, 1542; pith, 1543; wood, 1544; perennials, 1545; circulation of juices, 1550; decomposite organs, 1551; anomalies of vegetable development, 1559.
- Vegetables as indicating the nature of the soils they grow on, 2072; argillaceous, 2074; calcareous, 2075; siliceous, 2076; ferruginous, 2077; peaty, 2078; saline, 2079; aquatic, 2080; very dry, 2081.
- Vegetables, their sexuality, 1589; economy of aquatics, 1591.
- Vegetation as influenced by the atmosphere, 2265; water, 2266; carbonic acid gas, 2270; oxygen and azote, 2274; gravity of the atmosphere, 2279; temperature, 2283; vapor, 2288; clouds, 2289; dew, 2297; rain, 2300; frost, 2306; hail, 2308; snow, 2309; ice, 2311; wind, 2313; thunder, 2322; lightning, 2323.
- Vegetation as influenced by weather, 2245; heat and light, 2246; electricity, 2260; water, 2263; solar rays, 2259.
- Vegeto-animal matter, a term applied to one of the principal constituent parts of the farina or flour of some vegetable seeds. It is found in the largest proportion in grain, especially wheat, existing in a state of mechanical mixture with mucilage or starch.
- Vermueden*, Sir C., his work on draining land, page 1163. A. D. 1642.
- Veterinary operations on horses, 5861.
- Veterinary pharmacopœia, 5879.
- Villa of the Romans, 75; its division, 81.
- Villages, their establishment on estates, 3573; Bride-kirk, 3575; village seaport, 3577.
- Villages of Switzerland, 336.
- Villeneuve*, Comte Louis de, his work on agriculture, page 1175. A. D. 1819.
- Vine, its culture in France, 407.
- Vine, culture of, in Lombardy, 274; in Tuscany, 290.
- Vine, culture of, in Austria, 614.
- Vine, culture of, in Saxony, 597.
- Vine, its culture in Spain, 707.
- Vine, culture of, in Prussia, 579.
- Vine, culture of, at the Cape of Good Hope, 1094.
- Vine, culture of, in Madeira, 1123.
- Vine, its culture in Switzerland, 337.
- Vinet*, Elie, his work on agriculture, page 1171. A. D. 1607.
- Vineyards of Savoy, 361.
- Vineyards of the Jews, 33.
- Virgil*, his poems respecting agriculture, 47.
- Virgil, plough of, 112.
- Virgilian husbandry, a term made use of by some authors to express that sort of husbandry, the precepts of which are so beautifully delivered in Virgil's Georgics. Formerly the husbandry in this country was Virgilian, as is shewn by the method of paring and burning the surface, of rafting or cross ploughing, and of the care in destroying weeds, upon the same principle, and by much the same means. In those parts along the southern coast, where the Romans principally inhabited, not only the practice, but the expressions, are in many respect the same with those of the ancient Romans; many of the terms used by the ploughmen being of Latin origin; and the same with those used by those people on the like occasions. Tull, who has established a new method of husbandry, observes, that it is upon the whole so contradictory to this old plan, that it may be called the *antivirgilian husbandry*, and that no practice can be worse than the Virgilian, 47. 112.
- Virtues of plants, physiologically considered, 1471.
- Vives, ives, or strangles, 5774.
- Viviparous animals, 1938.

## W.

- Waggon of the Cape farmers, 1106.
- Waggons, 2619; Gloucestershire waggon, 2621; Berkshire, 2622; Norfolk, 2623; Rood's patent waggon, 2624.
- Wales, agriculture of, from the fifth to the seventeenth century, 197.
- Wales, agricultural survey of, 7043; North Wales, 7044; South Wales, 7045.
- Walker*, W., his essay on draining land, page 1170. A. D. 1813.
- Walking as a movement of the horse, 5900.
- Wall*, Richard, his dissertation on breeding horses, page 1165. A. D. 1768.
- Wallflower, culture of, 5082.
- Walls, their influence in producing heat, 2256.
- Walls, see Fences.
- Walnut trees in Savoy, 359.
- Warbles, 5820.
- Ware, in irrigation, 4074.

- Wark*, Dr. David, his work on agriculture, page 1164. A. D. 1761.
- Warp*, a slimy deposit let fall upon land by the sea tides in particular situations. The term is also sometimes applied to the ooze or slimy matter thrown up by the sea, 2148.
- Warping*, theory of its effects on soils, 2148.
- Warping*, 4117; history and theory, 4118; effects, 4119; season, 4121.
- Warrens*, rabbit, extent, stocking, &c., 6593.
- Warts*, 5821.
- Warwickshire*, agricultural survey of, 7012.
- Wash*, medicines used by veterinary practitioners, 5919.
- Washing of sheep*, 6441.
- Washington*, General George, his works on agriculture, page 1168. A. D. 1800.
- Wasp*, bee, and ant insects, 6904.
- Waste lands*, to improve, 4159; mountainous and hilly grounds, 4160; rocky surfaces, 4163; woody wastes, 4172; moors, 4181; peat mosses, bogs and morasses, 4183; marshes, 4197; downs and shore lands, 4203.
- Water*, its component parts, 2263; state of, in the atmosphere, 2266.
- Water meadows of the Romans*, 142.
- Water meadows of Orcheston*, 7031.
- Water*, to procure for live stock, 4127.
- Water*, boring for, 4148.
- Water*, its decomposition by plants, 1532.
- Water*, its influence on the distribution of vegetables, 1702.
- Water*, as an article of vegetable food, 1510.
- Water for farm yard and domestic purposes*, 4157.
- Water melon* (figured), of Egypt, 1057.
- Water*, to filtrate, 4158.
- Waterford*, agricultural survey of, 7088.
- Watering*, 2911.
- Watering arable lands*, 4124.
- Watering land by machinery*, 4111; by sea water, 4112.
- Watering machine for roads*, 3494.
- Watery head in sheep*, 6524.
- Wax*, from what plants obtained, manufactured, and used, 1420; butter of cacao, 1422; butter of cocoa, 1423; butter of nutmeg, 1424; tallow of croton, 1425; wax of myrtle, 1426.
- Wax tree of the Chinese*, 969.
- Weaning a foal*, 5977.
- Weasel*, to destroy, 6852.
- Weather and climate*, their influence on vegetation, 2245.
- Weather*, art of prognosticating, 2331; by the moon, 2334; barometer, 2340; hygrometer, 2354; pluviometer, 2360; thermometer, 2365; precedent, 2367.
- Weather of Britain*, study of, 2369.
- Weber*, F. Bd., his work on agriculture, page 1176. A. D. 1803.
- Wedder sheep*, a castrated male, 6413.
- Weeding tools*, 2393; pincers, or thistle drawers, 2394.
- Weeding among the Romans*, 139.
- Weeding*, 2904.
- Weeds or plants injurious in agriculture*, 5538; relative weeds, 5539; absolute weeds, 5540; perennial weeds, 5542.
- Weighing machine*, 2461; *Weir's*, 2463; for sacks, 2464.
- Weighing cage*, 2461.
- Weir's improved cultivator*, 2534.
- Weir's expanding bean drill*, 2559.
- Weir's manuring one row turnip drill*, 2560.
- Weir's improved hay or corn rake*, 2596.
- Weld*, or dyers' wood, its culture and use, 5377.
- Wells*, 4140; digging, 4141; steining, 4142; use of the auger in well digging, 4144; raising water from, 4153.
- Wells of China*, 987.
- Wells of Persia*, 863.
- Welsh cattle*, 6127.
- West coast of Africa*, agriculture of, 1077.
- West India islands*, agriculture of, 1172; Cuba, 1173; Jamaica, 1174; other West India islands, 1200.
- West Lothian*, or Linlithgowshire, agricultural survey of, 7059.
- West Riding of Yorkshire*, agricultural survey of, 7020.
- Western*, C. C. Esq., M. P., his work on agriculture, page 1171. A. D. 1824.
- Westmeath*, agricultural survey of, 7085.
- Westmoreland*, agricultural survey of, 7026.
- Weston*, Richard, Esq., his works on agriculture, page 1165. A. D. 1769.
- Wexford*, agricultural survey of, 7078.
- Wheat*, culture of, 4599; species and varieties, 4601; soils, 4612; sowing, 4626; dibbling, 4630; harvesting, 4636; produce, 4641; uses, 4644.
- Wheat*, culture of, in Flanders, 454.
- Wheat*, culture of, in Egypt, 1053.
- Wheat*, dibbling of, in Norfolk, 7003.
- Wheel barrows*, 2449.
- Wheel ploughs*, 2506; Scotch plough with wheels, 2507; *Wilkie's* single horse wheel plough, 2508; *Beverston* plough, 2512; *Hampshire* plough, 2513; *Norfolk* wheel plough, 2516; *paring* plough, 2517; *draining* ploughs, 2518.
- Wheels*, relatively to the wear of roads, 3474.
- Whey*, 6380.
- Whim*, a flow moss so called, improvement of, 7052.
- Whin*, or furze, culture of, 5076.
- Whinstone*, 3390.
- Whipping out grain*, 2965.
- Whirlbone strains*, 5830.
- White*, Stephen, M. A., his work on bees, page 1164. A. D. 1756.
- White*, Rev. Andrew, and Duncan Macfarlane, D. D., their work on agriculture, page 1170. A. D. 1811.
- White beet*, culture of, in Flanders, 469.
- White beet*, or mangold wüzel, culture of, 4962.
- Wicket gates*, 2869; see *Gates*.
- Wicklow*, agricultural survey of, 7077.
- Wiegand*, J., his work on agriculture, page 1176. A. D. 1762.
- Wight*, Andrew, his work on agriculture, page 1165. A. D. 1778.
- Wild boar*, 6531.
- Wild breed of cattle*, 6130.
- Wild men and women of Malacca*, 938.
- Wild pine apple*, a hedge plant of the West Indies, 1196.
- Wildman*, Thomas, his treatise on bees, page 1165. A. D. 1768.
- Wilkie's horse hoe and drill plough*, 2542.
- Wilkie's horse hoe and drill harrow*, 2543.
- Wilkie's wheel plough*, 2508.
- Willey*, Andrew, professional turnip sower in Northumberland, 7024.
- Williams*, T. W., his farmer's law book, page 1170. A. D. 1819.
- Williamson*, Captain Thomas, his work on agriculture, page 1170. A. D. 1810.
- Wiltshire*, agricultural survey of, 7030; South Wiltshire, 7331; North Wiltshire, 7032.
- Wind*, theory of, 2313.
- Wind broken in pneumonia*, 5789.
- Wind colic in sheep*, 6511.
- Winnowing corn among the Romans*, 137.
- Winnowing machine*, 2452.
- Winter*, George, his work on agriculture, page 1166. A. D. 1787.
- Wire worm*, or crane fly, *Tipula*, 6907. 6921.
- Wisset*, Robert, Esq., his treatise on hemp, page 1169. A. D. 1804.
- Woad*, culture of, in Flanders, 483.
- Woburn dairy*, 6999, fig. 775.
- Wood or woody fibre*, physiologically considered, 1466.
- Wood*, its culture and management, 5364.
- Wood louse*, *Oniscus*, 6915.
- Woodlands*, 3627. 3629.
- Woodlands and forests of Flanders*, 519.
- Woods and forests in Switzerland*, 339.
- Woods and plantations of Dumbartonshire*, 7057.
- Woods and plantations*, judicious management of, in Derbyshire, 7014.
- Woods and plantations of Cheshire*, 7028.
- Woods and plantations of Aberdeenshire*, 7066.
- Woods and plantations of Perthshire*, 7063.
- Woodward*, or land reeve, 4276.
- Woody wastes*, to improve, 4172.
- Wool*, its nature and properties, 1815.
- Wool shears*, 2409.
- Worcestershire*, agricultural survey of, 7007.
- Working horned cattle*, 6125.
- Working classes*, amelioration of, in Sutherland, 7070.
- Working classes*, education of, in Devonshire, 7038.
- Worridge*, John, his work on agriculture, page 1165. A. D. 1669.
- Worm tribes injurious in agriculture*, 6921; slug, 6922; snail, 6922.
- Worm under the horn*, a disease in sheep, 6524.
- Worms*, common, to destroy, 6922.

Worms in horses, 5809.  
 Worms in sheep, 6527.  
 Worms subjected to cultivation, 6821; leech, 6845; edible snail, 6843.  
 Worms in use as food by the Chinese, 944.  
 Wornalls or puckeridge in cattle, 6274.  
 Wounds and accidents of vegetables, 1639; incisions, 1640; boring, 1641; girdling, 1642; fracture, 1643; pruning, 1644; grafting, 1645; filling, 1646; destruction of buds, 1647; of leaves, 1648; decortication, 1649.  
 Wounds in horses, treatment of, 5862.  
*Wright*, Sir James, Bart., his work on agriculture, page 1167. A. D. 1796.  
*Wright*, Rev. Thomas, his work on agriculture, page 1166. A. D. 1789.

## Y.

Yam, *Dioscorea sativa*, culture of, 1193.  
 Yarrow, culture of, in Derbyshire, 7014.  
 Yellows, or liver disease, 5810.  
 Yellows in cattle, 6268; hot, 6261.  
 Yeoman, a term applied to the first or highest degree of plebeians in this country. The yeomen are properly freeholders, and such as cultivate

their own lands. This useful and important class of society has been within these few years considerably lessened, 7172.  
 Yoking draught animals, 2997.  
 Yorkshire, agricultural survey of, 7019.  
*Young*, Arthur, F.R.S., his works on agriculture, page 1164. A. D. 1767.  
*Young*, David, his work on agriculture, page 1166. A. D. 1786.  
*Ywart*, A. Victor, his works on agriculture, page 1175. A. D. 1819.

## Z.

Zea mays, or India corn, its culture, 4734.  
 Zetland and Orkney cattle, 6123.  
*Zhmens*, Capt. H. Adj. Von., his work on agriculture, page 1176. A. D. 1796.  
*Zicgerus*, Antoine, his work on agriculture, page 1175. A. D. 1735.  
*Zizania aquatica* (figured), or Canadian millet, its culture, 4732.  
*Zizyphus lotus*, culture of, in Tripoli, 1067.  
*Zizyphus paliurus* (figured), a hedge plant in Italy, 265.  
 Zoology, 1801; see Animals.

THE END.







YC 59232

