

# FARM AND FIRESIDE

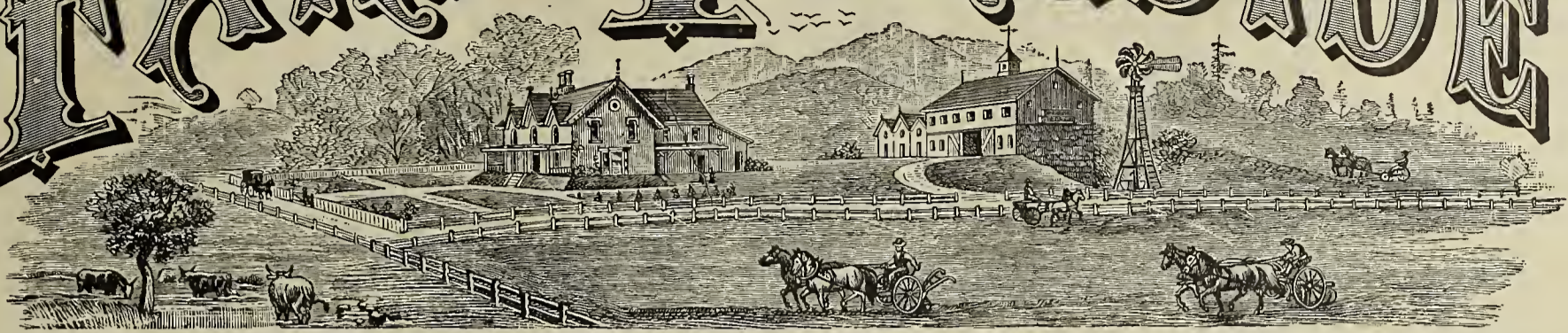

LIBRARY  
APR 6 1900

Vol. XXIII. No. 13

EASTERN EDITION

APRIL 1, 1900

Entered at the Post-office at Springfield, Ohio, as second-class mail matter

TERMS 50 CENTS A YEAR 24 NUMBERS

## "Gems From the Poets"

THE CREAM OF POETICAL LITERATURE

A DELIGHTFUL BOOK CONTAINING

400 Poems and Pictures

THIS work contains a discriminating collection of what may be considered the Gems from all the poets. Only representative productions are used, and as a result we have the very highest class of literature. It contains choice poems for all moods, all occasions, and will surely please every one.

### It is Fully Illustrated

It is the *only* low-priced collection of poems *fully* illustrated. In fact, it is more completely illustrated than any similar work ever issued, either high-priced or low-priced; each page has one or more illustrations.

The designing and engraving of the illustrations alone cost at least \$20,000. The pages are large—7¾ by 10 inches—and the book is large in proportion.

In addition to the large list of poems by the masters of literature and their superb illustrations the work contains a very interesting collection of

*Portraits and Biographies  
Of Popular Poets . . . . .*



PARTIAL LIST OF AUTHORS REPRESENTED

Whittier	Longfellow	Lowell
Bryant	Poe	Holland
Riley	Burns	Hood
Swinburne	Moore	Shelley
Dante	Milton	Wordsworth
Tennyson	Angelo	Howe
Schiller	Pope	Byron
Shakspeare	Scott	Emerson

We feel free in saying that no better value has ever been offered by any paper than this great work, and the Farm and Fireside one year, for only 40 cents.

We Will Send This Book, and the Farm and Fireside One Year, for **40 Cents**

(When this offer is accepted the club-raiser may have either the regular cash commission or the name may be counted in a club)

Given as a Reward for a Club of TWO Yearly Subscriptions to the Farm and Fireside.

POSTAGE PAID BY US . . . .  
ORDER BY PREMIUM NO. 26.

Address FARM AND FIRESIDE, Springfield, Ohio



OLD AUNT MARY'S

WASN'T it pleasant, O brother mine,  
In those old days of the lost sunshine  
Of youth—when the Saturday's chores were through,  
And the "Sunday's wood" in the kitchen, too,  
And we went visiting, "me and you,"  
Out to Old Aunt Mary's?

It all comes back so clear to-day!  
Though I am as bald as you are gray—  
Out by the barn-lot and down the lane,  
We patter along in the dust again,  
As light as the tips of the drops of the rain,  
Out to Old Aunt Mary's!

We cross the pasture, and through the wood  
Where the old gray snag of the poplar stood,  
Where the hammering "red-heads" hopped awry,  
And the buzzard "raised" in the "clearing" sky  
And lolled and circled as we went by  
Out to Old Aunt Mary's.

And then in the dust of the road again;  
And the teams we met, and the countrymen;  
And the long highway, with sunshine spread  
As thick as butter on country bread,  
Our cares behind, and our hearts ahead  
Out to Old Aunt Mary's

Why, I see her now in the open door,  
Where the little gourds grew up the sides and o'er  
The clapboard roof! And her face—ah, me!  
Wasn't it good for a boy to see—  
And wasn't it good for a boy to be  
Out to Old Aunt Mary's?

And, O my brother, so far away,  
This is to tell you she waits to-day  
To welcome us—Aunt Mary fell  
Asleep this morning, whispering, "Tell  
The boys to come!" And all is well  
Out to Old Aunt Mary's.

JAMES WHITCOMB RILEY.



# The Popular Series of Pictures

ON HEAVY ART-PAPER 12½ BY 16 INCHES

THREE Elegant Pictures, and the Farm and Fireside One Year, for 35 Cents  
Any TEN of These Pictures, and the Farm and Fireside One Year, for 50 Cents



TO MEET a wide-spread demand for a large collection of medium-sized pictures of a popular kind we have arranged to produce the following One Hundred pictures. These Pictures are in the present very popular black and white style, and are in every way artistic and tasty. Surely no one would want to hang a chromo or lithograph on the wall as being representatives of art in these days. In the Popular Series all the pictures are reproduced by the photographic process of engraving, giving them a softness not otherwise obtainable and insuring absolute fidelity to the originals.

SIZE.—They are produced on highly finished, heavy art-paper and are 12½ by 16 inches in size including the margins; without margins they are 7 by 10 inches, and larger, varying according to the subjects. They are suitable for framing and just the right size to complete the decoration of a room. For a portfolio they constitute a most interesting collection.

## Three Pictures Absolutely Free

**35 Cents** The clubbing rate of the Farm and Fireside without a premium is 35 CENTS, but as a SPECIAL METHOD of introducing these pictures we will give any THREE of them FREE to every one who sends 35 CENTS for one year's subscription to the Farm and Fireside, provided the pictures are selected when the subscription is sent in.

*(When this offer is accepted no commission will be allowed and the name will not count in a club)*

NOTE—Do not confuse these with the Peerless Pictures, size 20 by 25 inches, which we also offer in connection with the Farm and Fireside.



No. 1533

DEFIANCE

Painted by Landseer

**THE POPULAR SERIES** Contains Reproductions of Famous Paintings; Examples of Renowned Architecture, including Temples, Castles, Churches and Public Buildings; Magnificent Landscapes of Mountains, Lakes and Streams, and Notable Scenes from History and Legend; the whole world having been drawn upon to form a supremely interesting collection unequalled for decoration, entertainment and education.

- |   |   |  |   |
|---|---|--|---|
| 1501 ABBOTSFORD, SCOTLAND                         | 1527 CHRISTIAN MARTYRS. Painted by Dore               | 1552 IMMACULATE CONCEPTION, THE. Painted by Murillo  | 1578 PRODIGAL SON, THE. Painted by Dubufe                 |
| 1502 ACROPOLIS, THE, ATHENS                       | 1528 CINDERELLA (from a painting)                     | 1553 INTERRUPTED FESTIVAL, THE. Painted by Herpfer   | 1579 QUEEN OF FLOWERS. Painted by Lefler                  |
| 1503 AFTER WORK. Painted by Holmes                | 1529 COCOANUT GROVE, FLORIDA                          | 1554 JACK ASHORE. Painted by Bacon                   | 1580 RIALTO BRIDGE, VENICE                                |
| 1504 A LA PASTORALE                               | 1530 COLOSSEUM, ROME                                  | 1555 JEALOUSY  | 1581 RUINS OF THE FORUM (as seen from the Capitol)        |
| 1505 ALHAMBRA, THE, SPAIN                         | 1531 COLUMBIAN FOUNTAIN                               | 1556 JULY COLUMN, THE, PARIS                         | 1582 SABINES, THE. Painted by David                       |
| 1506 ALHAMBRA, COURT OF LIONS IN                  | 1532 CROWN, THE                                       | 1557 KAGO, THE                                       | 1583 ST. PAUL'S CATHEDRAL, LONDON                         |
| 1507 ALHAMBRA. COURT OF JUSTICE IN                | 1533 DEFIANCE, OR STAG AT BAY. Painted by Landseer    | 1558 KISS ME (Child and Dogs). Painted by Holmes     | 1584 SEARCHING THE SPY. Painted by A. de Neuville         |
| 1508 ARABIAN WEDDING PROCESSION                   | 1534 DIANA OR CHRIST. Painted by Long                 | 1559 LAKE BLANCHE, UTAH                              | 1585 SUTHERLAND FAMILY, THE. Painted by Landseer          |
| 1509 ARCH OF CONSTANTINE, ROME                    | 1535 DONNER LAKE, CALIFORNIA                          | 1560 LITTLE SHEPHERDESS, THE. Painted by Koller      | 1586 SUNSET at CAPRI, ITALY                               |
| 1510 ARCH OF TRIUMPH, PARIS                       | 1536 EL CAPITAN, YOSEMITE, CALIFORNIA                 | 1561 LOVE'S GUIDANCE                                 | 1587 TEMPLE OF ISIS, OUTER COURT OF, EGYPT                |
| 1511 ARLINGTON HOUSE, VIRGINIA                    | 1537 FALLS OF THE RHINE                               | 1562 LUCERNE, SWITZERLAND                            | 1588 TEMPLE OF RAMESES III., AND PYLON OF PTOLEMY, KARNAK |
| 1512 ART WINS THE HEART. Painted by Thumann       | 1538 FIELD OF WATERLOO, BELGIUM                       | 1563 MELROSE ABBEY, SCOTLAND                         | 1589 TOWER OF LONDON                                      |
| 1513 AT THE SWAN-POND                             | 1539 FINDING OF MOSES. Painted by Schopin             | 1564 MILTON DICTATING. Painted by Munkacsy           | 1590 TWIN ROSEBUDS  |
| 1514 BABYLONIAN MARRIAGE MARKET. Painted by Long  | 1540 GALLERY OF SCULPTURE, CHATSWORTH, ENGLAND        | 1565 MOTHERHOOD                                      | 1591 TWO READERS, THE. Painted by C. Von Bodenhausen      |
| 1515 BASILICA OF ST. PETER'S, ROME                | 1541 GARDEN OF GETHISEMANE                            | 1566 MUSIC (from life)                               | 1592 VATICAN, THE, ROME                                   |
| 1516 BATTLE OF WAGRAM. Painted by Vernet          | 1542 GRAND OPERA HOUSE, PARIS                         | 1567 NOTRE DAME CATHEDRAL, PARIS                     | 1593 WASHINGTON, GEORGE, PORTRAIT OF. Painted by Stuart   |
| 1517 BIRTHDAY PARTY. Painted by Lefler            | 1543 GRAND OPERA HOUSE, PARIS, INTERIOR OF            | 1568 ORGAN-GRINDER, THE                              | 1594 WATERFALL BY MOONLIGHT. Painted by Rieger            |
| 1518 BIRTHDAY, THE (copy of painting)             | 1544 GREAT PYRAMID AND SPHINX                         | 1569 PALAIS DE JUSTICE                               | 1595 WEDDING SCENE IN VENICE                              |
| 1519 BOW RIVER AND TWIN PEAKS                     | 1545 HARPER'S FERRY                                   | 1570 PANORAMA OF PARIS                               | 1596 WESTMINSTER ABBEY, LONDON                            |
| 1520 CAMPANILE, OR LEANING TOWER OF PISA          | 1546 HEIDLEBERG CASTLE, GERMANY                       | 1571 PANORAMA OF VENICE                              | 1597 WHITE HOUSE, WASHINGTON, D.C.                        |
| 1521 CAN'T YOU TALK? Painted by Holmes            | 1547 HOME FROM THE FIRST VOYAGE. Painted by Rosenthal | 1572 PANTHEON, THE                                   | 1598 WINTER SCENE, NIAGARA                                |
| 1522 CAPITOL AT WASHINGTON, D. C.                 | 1548 HORSE FAIR, THE. Painted by Rosa Bonheur         | 1573 PARTHENON, THE, ATHENS                          | 1599 WISE AND FOOLISH VIRGINS, THE. Painted by Piloty     |
| 1523 CASTLE OF ST. ANGELO, ROME                   | 1549 HORSESHOE FALLS, NIAGARA                         | 1574 PHARAOH'S HORSES. Painted by Herring            | 1600 WRECK OF THE MINOTAUR. Painted by Turner             |
| 1524 CATHEDRAL AT MILAN, THE                      | 1550 HOSPICE OF ST. BERNARD, THE                      | 1575 PIED PIPER OF HAMELIN, THE. Painted by Kaulbach |   |
| 1525 CHRIST BEARING THE CROSS. Painted by Raphael | 1551 HOTEL DE VILLE, PARIS                            | 1576 PLACE VENDOME, THE                              |   |
| 1526 CHRIST BEFORE PILATE. Painted by Munkacsy    |   | 1577 PONCE DE LEON, ST. AUGUSTINE, FLORIDA           |   |

ORDER THE PICTURES BY THE NUMBERS, NOT NAMES

**FREE** Any TEN of the Pictures given as a premium for sending TWO yearly subscriptions (new or renewals) to the Farm and Fireside. . . . .

*The subscription may be either at the clubbing price, thirty-five cents without a premium to the subscriber, or when the subscriber takes a premium, at the advertised price for both paper and premium*

The Pictures Will be Sent by Mail, Securely Packed and Postage Paid. Entire Satisfaction Guaranteed

We Will Send Any Ten of These Pictures, and the Farm and Fireside One Year, for . . . . . **50 Cents**

*(When this offer is accepted the club-raiser may have either the regular cash commission or the name may be counted in a club)*

Postage paid by us

Address FARM AND FIRESIDE, Springfield, Ohio



# THE FARM AND FIRESIDE

## THE COLORADO STATE AGRICULTURAL COLLEGE

BY H. A. CRAFTS

**A**N AGRICULTURAL college situated in a section where the basic principle of agriculture is irrigation of necessity must be somewhat unique in its character. Its courses of study must largely conform to the peculiar surrounding conditions. Of such a nature is the State Agricultural College of Colorado, situated at Fort Collins. Indeed, the agricultural prospects of the state, then a territory, were so unpromising at the time the law providing for the establishment of the institution passed that the motives of the legislators were impugned by some. It was said that it was part of a log-rolling scheme to help through other legislation in which personal interests were involved.

But whatever the motives were for its enactment it was a very wise provision. Agriculture in spite of all obstacles has assumed an important place in the state's industries. The government survey estimates the number of acres in Colorado available for agriculture at eight millions. More than a quarter of this area is now actually under successful cultivation, and under the rapid expansion of the irrigation system the cultivated area is rapidly increasing. In the southern and western parts of the state there are still large areas of unimproved land, and large quantities of unappropriated water available for irrigation purposes. It is to the preparing of young men and women for the occupancy and successful cultivation of this land that the State Agricultural College is bending its efforts. For many years the institution was obliged to make way against many obstacles. The mining interests dominated the state's affairs, and the legislatures were sometimes slow to make necessary appropriations for its support. Selfish interests, envious of the advantages conferred by its location, repeatedly connived at its removal to other parts. But by constant vigilance and great labor the friends of the college have succeeded in placing it upon a firm basis and making it one of the foremost educational institutions in the West.

The initial step toward the establishment of the State Agricultural College was taken in 1870, when the territorial legislature took action thereon, providing for its location and prescribing how it should be managed, and naming twelve trustees to take the mat-

ter in charge. In February, 1874, the legislature made an appropriation of \$1,000 to aid the trustees in erecting buildings upon the grounds, which in the meantime had been presented to the state for college purposes at Fort Collins, the expenditure of which should be contingent upon the donation of an additional \$1,000, to be raised by subscription

are under operation, the central station at Fort Collins and one substation each at Rocky Ford and Cheyenne Wells. The valuation of college property was placed in 1898 at \$253,288.73.

Year by year the permanent improvements of the institution have been increased. There is a main building, chemical labora-

tion problems. Training is given in water measurements and in problems relating to irrigation, so as to furnish the students the foundation for service as canal superintendents, water commissioners, etc. Some time is given particularly to the study of canal and reservoir engineering, construction of diversion dams, the duty of water, canal management, flumes, fluming, weirs, problems in canal maintenance, etc. The location of the college in the midst of one of the best-irrigated valleys in the United States, with its large and well-constructed canals and storage reservoirs, gives excellent opportunities for this study. A large number of photographs and plans of irrigation-works have been collected and are in constant use. In view of the present and prospective importance of storage reservoirs in the West a course of six weeks is given especially to this subject. The principles of the construction of dams, both of earth and of masonry, and the computation of their stability are taught; also the causes of failures of dams, illustrated by photographs and lantern views of many dams. The large storage reservoirs near Fort Collins give convenient means for practical illustration.

A six-weeks' course of lectures on meteorology is also given in the fall term.

So, too, the peculiar conditions under which agriculture is pursued in Colorado are found to color and shape the courses of study prevailing in other departments, the department of agriculture especially. Instruction in horticulture is given by lectures. The first course of thirteen weeks in the fall term of the junior year deals mainly with methods. Under the general head of vegetable-gardening the principal topics considered are the best soil and situation for a garden, the manner of laying out a garden, the irrigation of garden crops, the rotation of crops, the methods of planting and management, etc. A portion of the term is devoted to forestry.

Besides the departments mentioned there are departments of zoology and entomology, mathematics, history, literature and German, English and philosophy, domestic science, political economy and logic, military science and commercial course.

Co-education is a feature of the college, and the students have all of the customary organizations among themselves as usually mark educational institutions of this kind. In 1899 the college had an attendance of three hundred and forty-five students, two hundred and fifty-one of whom were young men and ninety-four of them young women.

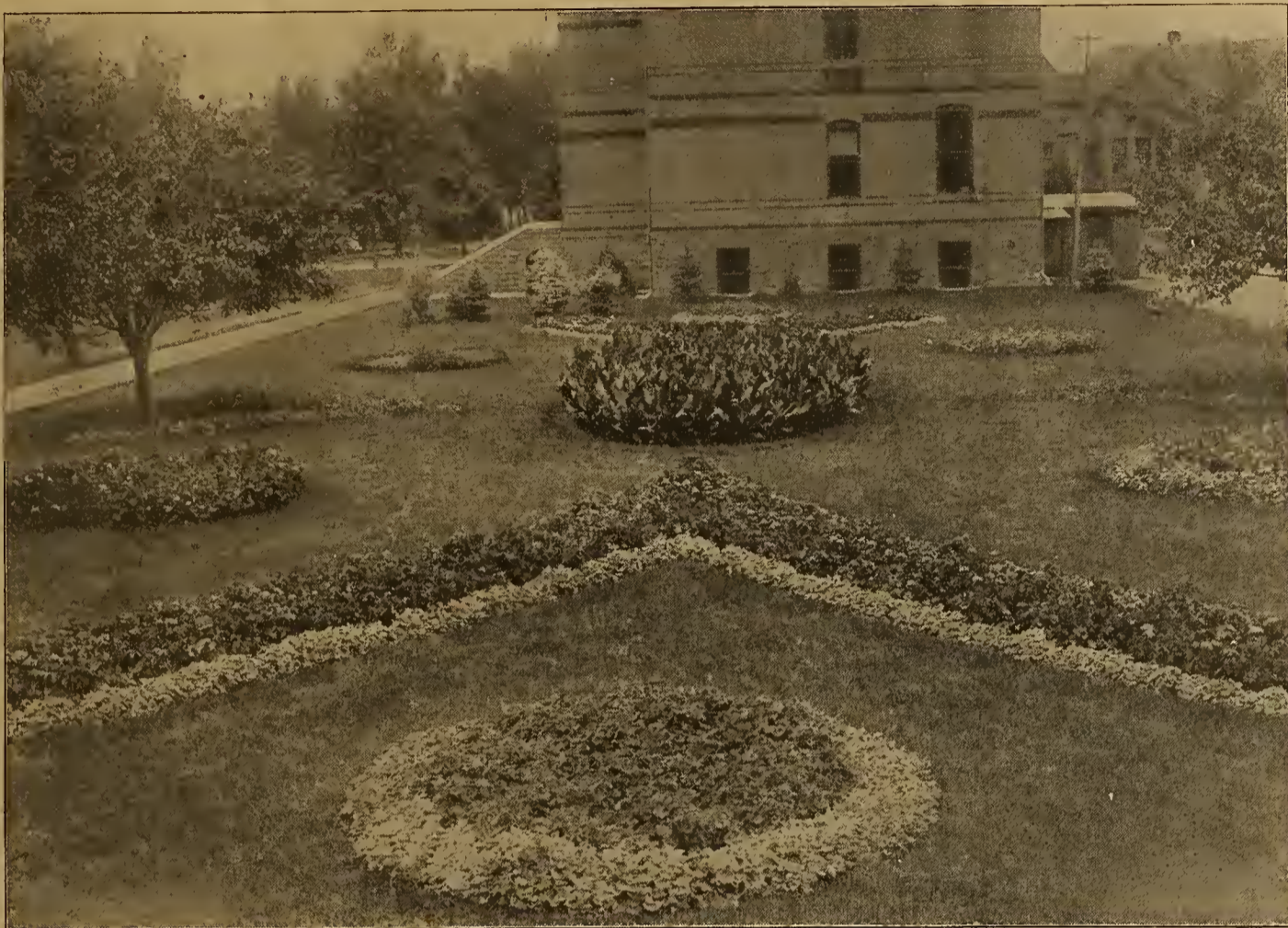

A GLIMPSE OF THE GROUNDS IN SUMMER-TIME

ter by the trustees. The Fort Collins grange subscribed \$100 of this amount, and when the building enterprise seemed in danger of lapsing by the limitation of time the grange got up a picnic, and during the holding of the picnic twenty acres of the college land were plowed and seeded. The land was sown to wheat, which yielded at harvest-time three hundred and seventy-five bushels. The college rights were thus saved by the public spirit of a few farmers and their wives. The land donated to the college was composed of two hundred and forty acres of prairie land almost adjoining the town of Fort Collins. The land was the joint gift of five citizens.

When the state constitution was adopted in 1876 the agricultural college became an institution of the state, and was placed under a board of eight trustees appointed by the governor. A mill tax of one tenth of a mill upon the entire taxable property of the state was at first levied for its support. Later this rate was increased to one fifth of a mill. The institution also in the meantime became a beneficiary of both the Morrill and Hatch bills. For the fiscal year of 1898-1899 the income of the institution from all sources was as follows: Income land fund, \$8,000; Hatch act, \$15,000; Morrill fund, \$25,000; state tax fund, \$37,000; special fund from the sale of college products, \$1,000; making a total of \$86,000. Three experiment stations

tory, agricultural hall, department of irrigation engineering, domestic-economy building, horticultural hall, department of mechanical engineering, commercial department, besides a college barn and various other farm and horticultural structures. The college farm has been improved until nearly all the ground outside of the college campus has been brought under cultivation. The experimental grounds have been especially well improved, and the institution being well supplied with water for irrigation has a thorough system of ditches, laterals and reservoirs. An extensive system of shaded walks and drives has also been laid out, extending through the campus and the greater part of the farm lands.

The peculiar conditions surrounding the cultivation of land in Colorado stamp their individuality upon nearly all of the practical departments of the college. Soil, climate and the art of irrigation must be considered with reference to the generality of experiments in agriculture, horticulture and civil engineering. The last-named is an especially marked department in the institution, and the head of the department, under a comparatively new order of things, has been made the director of the experiment stations. In the course of study in this department more than usual attention is paid to hydraulics and to engineering applied to irri-



A VIEW OF THE BUILDINGS OF THE STATE AGRICULTURAL COLLEGE OF COLORADO



## FARM AND FIRESIDE

PUBLISHED BY

THE CROWELL &amp; KIRKPATRICK CO.

OFFICES:

147 Nassau Street, New York City  
 Springfield, Ohio  
 204 Dearborn Street, Chicago, Illinois

Subscriptions and all business letters may be addressed to "FARM AND FIRESIDE," at either one of the above-mentioned offices; letters for the Editor should be marked EDITOR.

## TERMS OF SUBSCRIPTION

One Year - (24 Numbers) - 50 Cents  
 Six Months - (12 Numbers) - 30 Cents

The above rates include the payment of postage by us. All subscriptions commence with the issue on press when order is received.

Subscribers receive this paper twice a month, which is twice as often as most other farm and family journals are issued.

**Payment**, when sent by mail, should be made in Express or Post-office Money-orders, Bank Checks or Drafts. WHEN NEITHER OF THESE CAN BE PROCURED, send the money in a registered letter. All postmasters are required to register letters whenever requested to do so. DO NOT SEND CHECKS ON BANKS IN SMALL TOWNS.

**Silver**, when sent through the mail, should be carefully wrapped in cloth or strong paper, so as not to wear a hole through the envelop and get lost.

**Postage-stamps** will be received in payment for subscriptions in sums less than one dollar, if for every 25 cents in stamps you add one-cent stamp extra, because we must sell postage-stamps at a loss.

**The date** on the "yellow label" shows the time to which each subscriber has paid. Thus: Apr 1900 means that the subscription is paid up to April, 1900; May 1900, to May, 1900, and so on.

**When money is received**, the date will be changed within four weeks, which will answer for a receipt.

**When renewing** your subscription, do not fail to say it is a renewal. If all our subscribers will do this, a great deal of trouble will be avoided. Also give your name and initials just as now on the yellow address label; don't change it to some other member of the family; if the paper is now coming in your wife's name, sign her name, just as it is on the label, to your letter of renewal. Always name your post-office.

## The Advertisers in This Paper

We believe that all the advertisements in this paper are from reliable firms or business men, and do not intentionally or knowingly insert advertisements from any but reliable parties; if subscribers find any of them to be otherwise we should be glad to know it. Always mention this paper when answering advertisements, as advertisers often have different things advertised in several papers.



"THE Conference Currency bill," says Mathew Marshall, in the "Sun," "has become a law, exactly as was expected. It was passed last Tuesday (March 13th) by the House of Representatives, without amendment, just as it came from the Senate, and was signed by the president the following day. The various opinions that were expressed in regard to its probable effect, while it was pending, will therefore soon be put to the test of experience and be confirmed or contradicted by practical results.

"The passage of the bill may fairly be regarded as marking the end, for the present, of the efforts for currency reform which have been making ever since the beginning of the bond issues under President Cleveland's administration. The agitation for free silver had created serious doubts as to the maintenance by the government of gold payments, and when early in 1894 it led to a run on a treasury depleted by a deficient revenue, for the redemption in gold of the government notes, there was no alternative to government bankruptcy but the bond issue which was then made, and which was followed by others until \$262,000,000 of bonds had been sold, nominally to provide gold for redemption under the resumption act of 1875, but really to pay current expenses. After various schemes to avert a future recurrence of the mischief had been devised and urged upon Congress without effect, a convention of bankers and business men, called by the Indianapolis Board of Trade, met at Indianapolis to consider the subject, in January, 1897. This convention appointed a monetary commission, which held many sessions in Washington in the autumn of 1897, and after much labor agreed upon a plan of currency reform, which was printed and widely published. In its entirety the plan was never embodied in a bill, but various features of it were made the basis of financial measures, none of which, unless the present law be regarded as one of them, were successful.

"It is to the credit both of the Indianapolis convention and of its monetary commission that they never took the position on which

some of their ill-informed supporters at one time so strenuously insisted—that new legislation was necessary to establish the gold standard in this country. On the contrary, the convention at the outset declared for the 'present' gold standard; and its commissioners, in their report of December of the same year, described as one object of their proposed scheme 'the continued maintenance' of that standard. It was reserved for politicians and newspaper editors subsequently to discover that the gold standard had never been established by law among us, and to insist that a special act for the purpose was needed. The bill just passed has settled the question by explicitly recognizing the gold dollar, made the unit of value by section 14 of the Mint act of 1873, embodied in section 3,511 of the United States Revised Statutes, as still being the standard, and by merely providing for its maintenance.

"The plan of currency reform devised by the monetary commission of the Indianapolis convention consisted of thirty-nine separate articles. Of these articles some have been incorporated into the bill which has just been enacted, but the fundamental idea on which the plan was based has been discarded. That idea was the retirement of all government paper currency and the substitution for it of bank-notes secured, not by the deposit of government bonds, but by a common guaranty fund contributed by all banks issuing circulating notes, by a first lien upon their assets and by the personal liability of bank shareholders. The retirement of the government notes, though at first strenuously urged, was long ago abandoned, and now the provision for the issue of bank-notes secured by government bonds has been made so liberal that the agitation for bank currency secured in any other manner must necessarily cease also.

"Indeed, so far as any legislation by Congress is irreversible, that may be regarded as such which the new law embodies for the perpetuation both of government notes and of bank-notes secured by government bonds. After years of controversy the government notes, which were first issued as a temporary expedient for war purposes, are now recognized as a permanent element of the national financial system. Special divisions of the Treasury Department are to be devoted to them, and ample provision is made for their redemption on demand in gold. Hereafter any proposition for their retirement will be an assault upon a time-honored and respected institution which can succeed only by the clearest demonstration that it is justified. The creation of \$840,000,000 of long-term government bonds, available as a basis of issue of an equal amount of bank-notes, objectionable as it is in other respects, silences the clamor that the national-bank system is not sufficiently 'elastic' to supply the currency needs of the people.

"On all other points the new law is by no means a finality, but leaves a number of questions to be settled hereafter. Of these the most important is that of the disposal of the 400,000,000 of silver dollars now stored in the treasury vaults, and it soon will become a very pressing one. These dollars are represented in the circulation by silver certificates, which the law aims at making indispensable by giving them the exclusive field for denominations of paper money below \$5, but it does not provide for redeeming them on demand in gold, so that their maintenance at parity with gold will continue to rest as it rested before, on the government's agreement to accept them as equal to gold for public dues."

IN THE "Atlantic Monthly" for March Secretary Olney concludes an article on our foreign policy as follows:

"A consequence of the new international position of the United States must be to give to foreign affairs a measure of popular interest and importance far beyond what they have hitherto enjoyed. Domestic affairs will cease to be regarded as alone deserving the serious attention of Americans generally, who in their characters, interests and sympathies cannot fail to respond to the momentous change which has come to the nation at large. Such a change will import no decline of patriotism, no lessening of the loyalty justly expected of every man to the country of his nativity or adoption. But it will import, if not for us, for coming generations a larger knowledge of the earth and its diverse peoples; a familiarity with problems world-wide in their bearings; the abatement of racial prejudices; in short,

such enlarged mental and moral vision as is ascribed to the Roman citizen in the memorable saying that, being a man, nothing human was foreign to him."

MR. BIRD S. COLER, controller in the first administration of Greater New York, declares that the city is being plundered by men compared with whom Tweed was an amateur, and who have made legalized robbery of the city perfectly respectable. He says: "The city has been robbed outrageously in the purchase of supplies, and I am now powerless to prevent it. There is a concerted movement to prevent the finance department from protecting the city treasury. We have held up many bills here, and in some cases the parties have accepted large reductions because their claims were so fraudulent they dared not go into court, although they could have recovered the full amount under existing laws and rulings. When I find the city has been charged double the market rate for an article I must prove fraud or there is no defense, and the corporation counsel will confess judgment. To prove fraud and bribery is a very difficult matter."

The municipal misgovernment of the greatest city of the land finds many imitators. There are cities of a few thousand inhabitants that have adopted the corrupt methods of Tammany rule. Citizens of all cities and towns must guard their local government with increasing care, and establish a rigid quarantine against the plague of municipal corruption. It will avail nothing to hold up the hands in horror at the thieving rulers of New York, and overlook the pirates at home.

COMMENTING on the triumph of the shamrock the Chicago "Times-Herald," under date of St. Patrick's day, says: "Wherever the English tongue is spoken the shamrock will be displayed to-day as an emblem and token of Irish irrepressibility. By the special permission of the Queen the green will be worn above the red by British soldiers the world over, and it will be worn by Tommy and Sandy as well as by Terry as symbolic of that comradeship that has carried the flag of St. George, St. Andrew and St. Patrick over every sea and under every sky.

"One of the most significant bits of bunting flying in the world to-day is the British Union Jack that floats over the presidency of the Orange Free State with a four-leaved shamrock embroidered in the corner by Lady Roberts, wife of 'Little Bobs.'

"One of the puzzles of the past century has been the attitude of the Irish to the United Kingdom. Whether living in Ireland, Great Britain, the United States or any land where the English language is spoken, they have never ceased to use its utmost resources to refuse consent to the union. Verbally as implacable as death they have stood shoulder to shoulder with the sons of Scotland, England and Wales in carrying forward the work of the empire in peace and in war around the globe.

"In the British parliament to-day Irish nationalists never cease to denounce the war in the Transvaal. But in South Mayo, where the seat of Michael Davitt was vacated by his resignation, Major John McBride, the commander of the Irish brigade in the Boer army, received only four hundred and twenty-seven votes in a constituency numbering five thousand electors, and was defeated by another nationalist by one thousand nine hundred and seventy-four votes. Evidently much as the Irish enjoy baiting John Bull they have no idea of surrendering that pleasure to any Irishman who is at war with him under any alien flag.

"Under the shamrock, the thistle, the rose or the Stars and Stripes the typical wearer of the green is the realization of Addison's portrait:

"In all thy humors, whether grave or mellow,  
 Thou'rt such a touchy, testy, pleasant fellow,  
 Hast so much wit and mirth and spleen about thee,  
 There is no living with thee, nor without thee."

THERE is much criticism of the proposed tariff on articles imported from Porto Rico," says the "Rural New-Yorker." "That island came into the possession of this country as a result of the war with Spain. It is as much a part of our nation as Alaska. We have from the first opposed the purchase or

conquest of any of the Spanish islands. The trade they may give our manufacturers will, it seems to us, be more than offset by the competition of their products with those grown by the American farmer. Having acquired this island, however, and having stated that this was done in the interest of humanity and civilization, our government should have given the Porto Ricans an equal chance in our markets—that means free trade. We are speaking now of the moral side of the question. This seems to have been the first thought of the administration, but this plan was suddenly changed and a tariff—finally cut down to fifteen per cent of the ordinary duties—proposed. What brought about this change? The sugar trust and the tobacco trust have been accused of forcing this change, but we are frank to say that we do not believe it. We feel sure that the beet-sugar growers and the Connecticut tobacco-growers are directly responsible for the change. The president gave way to them because he honestly felt that they would be injured by free tobacco and sugar. Two years ago was the time to realize that a resident American should come in ahead of a Spanish islander. The tariff problem now comes home to this country in a troublesome way."

Bradstreet's says: "The proposed legislation regarding the Porto Rican tariff continues to occupy the attention of the Senate, and to call forth the most serious criticism that has been directed against any recent measure of the majority. The argument as to the constitutional features of the question continues to furnish material for speeches, but the serious interest in the matter hinges on the question of policy and expediency. The chorus of opposition to the bill has been swelled this week by the protest of the planters, merchants and manufacturers of Porto Rico, who make an earnest demand for the establishment of free trade with the island. They recognize that a revenue to support the insular government will be necessary, but they urge that the better method for raising that revenue would be by means of internal taxation, because by that system no restriction will be placed on the commerce of the island with the United States, and because the adoption of that system will be as simple in operation in the island as it is in the United States. Above all, they ask that free trade with the United States be given the island as a right. The advocates of the bill have been put clearly upon the defensive."

Dr. Schurman, the former president of the Philippine commission, forcibly expresses his opinion on the Porto Rican tariff question as follows:

"I agree with you that the United States is under obligations to extend its tariff laws to the island of Porto Rico. But I cannot accept your contention that this obligation is derived from the Constitution, which in my judgment does not of its own force apply to annexed territories. The obligation is moral, not constitutional. As the president said, with equal truth and felicity, it is 'our plain duty.'

"We are bound to this course by solemn promises. The supreme and irresistible reason for removing all customs barriers between the United States and Porto Rico is the promise made by General Miles when the first landing was made by American forces on the island, that the Porto Ricans should enjoy the same rights, privileges and immunities as the people of the United States. On this understanding the Porto Ricans accepted American sovereignty, not only without opposition, but with joyful trust and confidence. The present issue is simply this: Shall we repudiate or shall we fulfill the national engagements? Shall this great republic break faith with the little island of Porto Rico? Having secured the fruits of General Miles' promise, shall we now renounce the promise?"

"The American people will not tolerate any paltering with solemn obligations. Recognizing the national good faith as the nation's chiefest good, they will condemn any violation of it as the blackest crime. All over the country this Porto Rican question has stirred to the deepest the national heart and conscience; legislation inspired by a breach of good faith will bring a terrible Nemesis. It is said that a tariff is needed between Porto Rico and the United States to provide a case for the courts, to determine the extent of our jurisdiction over the dependencies, especially the Philippines. I answer that no convenience, no expediency, no other obligation ever justifies a breach of the national good faith."





### Fresh Bordeaux versus Ready-made

Some neighbors of mine have been using last year a certain much-advertised "prepared Bordeaux mixture." One of them tried to convince me to use this mixture instead of making my own. I confess that there is something quite tempting in the idea and prospect of being able to make a good spraying liquid by simply adding water to a ready-made mixture instead of having to weigh out and dissolve copper sulphate in one vessel and slake lime in another, and then mix the two liquids in certain proportions and test them and strain them, etc. It is this consideration of convenience and of saving labor which will doubtless induce many people to use this prepared mixture. But I cannot forget that at every fruit-growers' meeting where this matter was discussed by experts the latter invariably emphasized the need of having the mixture freshly prepared. So I thought of asking my nearest station (that of Geneva, New York) whether they had used that particular prepared mixture, and if so with what results. The following answer from the assistant botanist is rather more general in tone than I wished, but I give it here as showing the drift of the station people's ideas:

"Prepared Bordeaux mixtures as a rule give unsatisfactory results when used under parallel conditions with the regular mixture. Much time can be saved in preparing the Bordeaux if a stock solution of each constituent is kept on hand. Thus by dissolving forty pounds of bluestone in forty gallons of water a stock solution is obtained containing one pound of sulphate in each gallon of solution. The sulphate dissolves readily if suspended in a fertilizer-sack so as to dip from six to nine inches into the water. The forty pounds will in this way be dissolved over night, while otherwise it would take either much valuable time to keep the water in motion, or several days if left quietly at the bottom of the barrel. So much for the sulphate solution.

"The lime is best prepared in stock also by slaking a bushel or more at once, and keeping the slaked lime in a vessel so as to retain a layer of water six inches in depth over the lime at all times. With these two stock solutions and a little red litmus-paper the work of preparation is very simple.

"From the stock solution of sulphate take one gallon of solution to each eight gallons of water in the mixture. From the lime stock add three gallons of the milk, or cream, of lime, test with red litmus-paper (obtainable at drug-stores in small strips). If enough lime has been added the paper will become blue, when the Bordeaux is ready for use. Stir thoroughly as the lime is being added.

"By renewing the water over the mass of slaked lime, and occasional stirrings while using, the tub of stock will last nearly the whole season."

**Litmus-paper** The use of litmus-paper is something new to me in this connection, yet it is most natural. In fact, I wonder that it has not been suggested before by any of our experts, so far as I am aware of. Heretofore we have always relied on the ferrocyanide of potassium test. This has only one object; namely, to show when our Bordeaux mixture begins to have an alkaline reaction. As long as it contains any free acid it is liable to scorch the foliage of the trees or plants which we spray with it. After the acid has been entirely neutralized by the added lime no injury can result to the foliage. All the directions for making the Bordeaux mixture have very carefully called for a full allowance of lime, as an excess is entirely safe, and better than even a slight shortage, especially if we add Paris green or other arsenical poisons to the mixture. It will probably be just as well to use litmus-paper in place of the ferrocyanide. I speak of blue and red litmus-paper. Of course, it is the same paper. The blue shows an alkaline reaction, the other an acid reaction. If you take a piece of litmus-paper and moisten it with vinegar, or anything that is acid even to a slight degree, the blue color will at once turn into a kind of pink; or if you moisten this pink or red paper with lime-water or any other alkaline substance, it will at once turn blue. This litmus-paper is cheap. If you wish to make the test in making the Bordeaux mixture, take a red strip, or if a blue one first make

it red by moistening with vinegar, and go ahead as told by Mr. Blodgett. It seems to me that a little bunch of litmus-paper belongs to the legitimate equipment of the farm. We have other uses for it besides the one mentioned. Often it is important to know whether a certain soil is of a sour (acid) or of an alkaline character. Most of the ordinary crops, especially garden crops, will not do their best on sour land. A little strip of litmus-paper placed firmly against a fresh cut, and of course still moist surface of the soil to be tested, and being covered with a little more of the same fresh soil, if this be the least acid will turn pink, while if the soil has the opposite character the paper will remain (or turn) blue. Any soil which turns litmus-paper pink I would, under ordinary circumstances, treat with applications of lime, say fifteen or twenty bushels to the acre. Wood ashes, of course, would also be a good thing. The one crop of all for which I rather like a soil that is a little sour (although well supplied with potash) is the potato. There is no easier and surer way of preventing the ravages of the dread potato-scab than a little acidity in the soil. The pink color of the paper brought in contact with the soil will show its having the desired acid reaction. The smoothest potatoes, even if not the largest yields, I have obtained on somewhat acid, mucky soil.

**Changing Chemical Character of Soils** It is easy enough to correct an overacid condition of our soils. Lime applications will do it every time. The only question is in what form to use the lime, and how to apply it most conveniently. Of course, fresh-slaked lime is better and stronger than old, air-slaked lime. But if I had plenty of the latter, which is simply a carbonate, and has lost its caustic properties, I would not hesitate to use it rather than spend money for fresh stone-lime. We can apply thirty, forty or fifty bushels of it to the acre without fear. It will do no harm. At the same time it will not have the full effect of the fresh or caustic form of lime in freeing locked-up plant-foods. But so long as you use enough of the carbonate of lime it will neutralize the acidity of your soil. If you spread it with a shovel or scoop you must try to put it on as evenly as possible all over the ground. A better way would be to sow it with an ordinary fertilizer-drill, then mix it well with the surface soil by shallow harrowing. Always put lime as near as possible to the surface. It will work down anyway, and naturally. To apply fresh stone-lime you will first have to water-slake it. This can be done by piling a few bushels in heaps scatteringly over the field, in a smooth bed or depression, then pile moist soil over it, and thus leave it for a week or two until it all falls to a powder. Should a rain happen to come it will not take long for the lime to slake. Then spread it the best you can.

**Raising Calves** A subscriber in St. Lawrence county, New York, writes me as follows: "I am raising two calves on the milk of a farrow cow. She gives about twenty pounds of milk a day, and I set it in a gravity separator, putting in as much water as milk. I let it set from one milking to another, and then feed it sweet. I take about one half pound of oatmeal, such as used for the table, and cook it ten or fifteen minutes, and it will make about two quarts of thick gruel. This, boiling hot, will warm the milk, and is enough for two calves. My calves are about one month old, and as nice as I ever raised on skim-milk. Oatmeal costs three cents a pound here." Good, hearty calves, such alone as are worth raising or liable to make good cows, will begin to eat hay and dry grain when only a few weeks old. By all means keep nice bright clover hay before them all the time. Buy some if you have none, or trade it in for timothy hay, which is not near as good for the purpose. Then carefully get the calf to eat bran and oats or oatmeal, with perhaps a little linseed-oil meal added. Some claim that a calf can be given as much of this as it will eat. It may do to treat some calves thus. I have one that will eat almost all you might feel disposed to give it. It will eat more than it can digest, and it is liable to get the scours. So you have to be careful and watchful all the time, and use discretion and judgment.

**Weeder Attachment for Cultivators** Weeders for both horse and hand use are coming more and more into common use on farms and in gardens. They are really rakes, as they just scratch the surface of the ground, leaving it smooth and free from weeds, with an inch or so of the top finely pulverized. I have used the Breed weeder in potatoes, peas, beans, cabbages and the like, and often with excellent success. Of course, the soil should be naturally mellow and entirely free from rubbish, stones, etc. My weeder did not work well on hard soil after rains had packed the surface. It did not work well so long as there were clods, no matter how small, or coarse stuff of any kind near the surface. I was told to try my weeder in the onion-patch also, but I never had the heart to do it. A reader now asks me what I think of a certain weeder attachment that can be fastened on any ordinary modern one-horse cultivator and will rake over the row of potatoes, corn, etc., on each side, while the cultivator itself takes care of the space between the two rows. I have not tried it, but believe that if the tool is properly made and constructed it would work well. At least there is nothing to hinder making good use of such a plan. I have a weeder attachment arranged on the same plan or principle to my hand-wheel hoe, and it does good work. T. GREINER.

### SALIENT FARM NOTES

**Teaching Practical Business** A few days ago I received a letter from a farmer in an adjoining state in which he stated that he had ordered some cow-peas from a party I am acquainted with, at a certain price a bushel, and that after sending in the money said party had written him that the price of peas had advanced about fifty cents a bushel; and to get them he would have to remit that amount in addition to what he had sent. He was indignant, and desired me to see said party about the matter and get an explanation. I met the gentleman yesterday and asked him what sort of a business he was doing, and handed him the letter. After reading it he explained as follows: "I wrote this person and several others, offering cow-peas at a certain price, 'for immediate acceptance.' Some of them did not send in their orders until several weeks later. In the meantime the demand had been such that we had decided to raise the price fifty cents a bushel. If these men had accepted our offer immediately on receipt of our terms they certainly would have received the peas at that price." By the way, this man is a grain-dealer, miller, orchardist and farmer, and he does an extensive business.

After hearing his explanation I said: "Don't you know that not one farmer in fifty knows anything about commercial terms? You wrote 'for immediate acceptance,' stating price of peas. You might as well have written 'jiminy crickets.' To most farmers commercial terms are Greek. If you desire that all farmers should understand exactly what you mean you must not use such commercial terms as 'for immediate acceptance,' but you must say, 'I will sell peas at this price only one week from date of this letter.' If you would do that they will understand you."

"Perhaps I should have written that or something similar, but my dealings are so largely with business men that I do not think of it," he replied. "It is a pity," he continued, "that our common schools do not teach these things. So many people obtain their entire education at our district schools that it seems to me the rudiments, at least, of letter-writing and commercial terms should be taught. Our mill has tried to do business with farmers—tried to sell them bran and feed stuffs in car-load lots, but we gave it up. The fact is they were too slow, too careless or too foolishly cautious. We have a rating; they have none. They can step into any bank in the United States and learn that we are responsible; the only way we can obtain their rating is by writing the bank in their town, and then very often the reply is unsatisfactory. The chief defect in our common school system is that they teach too much frippery and too little practical business."

Would it not be a grand good idea for school officers to suggest to the teachers they employ that they occasionally step aside from the regular routine and drill their pupils in business correspondence? Teach them how to begin and end a business letter; how to properly address and stamp envelopes, etc. Teach them how to ask for catalogues, for quotations on goods of dif-

ferent kinds, and how to order articles sent by freight, express and mail. A few lessons on these subjects would probably be worth as much to them as a whole term devoted to the "regular course." Only a few days ago a prominent business man said to me that he hoped the time was not far distant when such practical matters as these would be taught the "plain people" in the common schools. "Every person nowadays," said he, "has occasion to write plain business letters, and how much it would facilitate matters if all could do so in a manner that is direct and easily understood. I wish you could induce all school officers to insist that teachers shall teach these simple but important lessons, even if they are not down in their curriculum."

**The Orchard Carpenter** Just at this particular season of the year a great many people are reminded that the orchard has not received any attention in the matter of pruning for about a year, and straightway they send for a man who is known to be something of an orchard carpenter, and they tell him to take his implements and "fix up" the orchard. This the said carpenter proceeds to do, sawing and chopping right and left. When the job is completed the trees look as though they had been interviewed by a cyclone, and the ground is strewn with branches of all sizes. A practical orchardist would hesitate long before cutting off a branch two inches in diameter. And if he finally decides that it would have to be removed he would carefully cover the wound with grafting-wax. The orchard carpenter will slash off a branch three to five inches in diameter without a moment's hesitation, and then leave the wound for the tree and weather to take care of. This artist is governed by certain rules, which he has formulated in his own mind, and one could move a post by talking to it as quickly as to induce him to vary one of his rules.

Two years ago a neighbor turned one of these gentlemen loose in his orchard, and though there were only thirty trees, the product was eight good loads of brush. I looked some of the trees over last fall, and not one of the trees had healed over; but borers had entered at many of them, and were busy tunneling in every direction. Plainly the trees are doomed, and in a very few years not one will be left standing. This same man has a nice little orchard of pear-trees, and the artist mentioned induced him to believe that they were growing too tall, and that the branches should be cut back about one half. This was done, and with the upper half of the branches went a nice crop of pears. Last spring the owner asked me to come over and tell him why his pear-trees did not bear. I had to tell him the trees had been butchered, and that he would be lucky if he ever gathered ten bushels off the whole orchard. The trees are full of borers and blight, and their days will be few. "The time to prune a fruit-tree," said one of the most successful orchardists I know, "is when one can do it with a pair of good scissors. Never cut off a branch over half an inch in diameter if it can be avoided; and it can be if one is watchful when the tree is young."

**Length of Grape-vines** "How long should one allow grape-vines to grow?" asks an Iowa subscriber. On our rich prairie soil they may be allowed to run twenty feet or more with benefit. Those who grow grapes on sandy or clay soils usually set the vines six to eight feet apart and train them up stakes, keeping them pruned back to five or six feet in length. For a time I followed that plan, but in a very few years discovered that something was wrong. Another lot were planted eighteen feet apart and trained along a wire fence, and in just four years the vines covered the fence from end to end, and I have gathered hundreds of pounds of great clusters of the finest grapes one could desire from them. I keep them pruned so they do not overlap each other, and never saw vines do better. On our black rich soil the grape must have an abundance of room. Close pruning will destroy it.

The best way to propagate a fine grape a Missouri FARM AND FIRESIDE reader tells about, or any other grape, for that matter, is by layering. Dig a trench about four inches deep, and lay one of the vines in it and cover with earth. The spurs or branches of the vine should be allowed to stick up out of the ground, and each one of them will make a fine vine for setting out next spring. From a single vine I have obtained a dozen good plants. FRED GRUNDY.



# OUR FARM

## FARM THEORY AND PRACTICE

**MONEY WASTED IN FERTILIZERS.**—Competent authorities on the subject of commercial fertilizers estimate that one fourth of the vast sum expended for fertilizers is wasted. Out of every four millions of dollars invested in these carriers of plant-food one million might as well be thrown into the sea, so far as the farmers are concerned. This is the estimate of careful observers, and I believe that it is rather too small than too large. The waste is due both to the purchase of some elements in fertilizers that are not needed for the particular soil upon which they are applied, and to the failure to buy the needed elements at their lowest market price. Many a farmer is puzzled by this whole fertilizer question, and I wish that I could say something that would make it simpler for the puzzled man.

\*\*\*

**THE THREE ELEMENTS.**—There are at least ten elements in the soil necessary to plant growth. When any one of these ten is absent the ground is sterile—the plant refuses to grow. Seven of these ten elements are usually in the soil in such abundance and in such available form that we do not consider them at all. They are present, and that is the important item. We hardly know their names, and hardly care. Only three elements are considered by us, and that because experience has taught that any one or all of these three elements may be lacking in available form in our soil, not enough of one or two or all three to insure a full crop. These three that may not be in full supply are nitrogen, phosphoric acid and potash. It is the presence of any one or all of these elements in a fertilizer that gives value to the fertilizer.

\*\*\*

**SHALL WE BUY NITROGEN.**—Of the three elements that a fertilizer may contain nitrogen is the costliest. One pound of it costs the user about three times as much as a pound of phosphoric acid or of what potash would cost. One hundred pounds of nitrogen in a ton of fertilizer adds about fifteen dollars to the price of that ton. Both stable manure and clover are rich in this costly element. The man who saves his stable manure right, caring for the liquid especially because it is rich in nitrogen, and grows clover, peas or vetches, should not need nitrogen for his soil badly enough to pay the price every pound of it costs in a commercial fertilizer. He gets it from stable manure and from the air. The man who uses good sods in his farming should get away from the purchase of nitrogen; the man who grows staple crops and does not get away from the necessity of buying much costly nitrogen cannot expect much profit from farming. It is all right for the truck-farmer on high-priced land, but too costly for the ordinary farmer growing grain and grass. But farmers have liked to see that word nitrogen (or ammonia, which is the same thing, only in a weaker form) on the fertilizer-bag, not thinking how costly a pound this material is. So the manufacturer puts into the fertilizer just a little nitrogen, say one per cent, or twenty pounds in a ton, adding liberally to the price on that account, and the farmer is satisfied. If he uses two hundred pounds an acre he gets just two pounds of nitrogen on each acre. What a farce it is, to be sure, and yet usually adding from three dollars to five dollars to the retail price a ton! Try to get nitrogen in manure, clover, peas and other aids, and discard it in the fertilizer.

\*\*\*

**STATEMENTS IN ANALYSES.**—If we can afford to drop the nitrogen, and we either should do so, or, if nitrogen must be bought, get a fertilizer sufficiently rich in it to do practical good, there remain only available phosphoric acid and potash to be considered. There is a lot more printing on the bag, but the buyer must fix in mind for once and all that the extra printing and extra long names and extra figures are placed upon the bag merely as an imposition upon the buyer. They make a long story out of a short one, but do not add one cent to the value of the fertilizer. The second row of figures is valueless. The law requires that the manufacturer guarantee the first row, and the second row is printed on the bag merely to impose upon the buyer. If the fertilizer contains no nitrogen (ammonia), then consider only "available phosphoric acid" and "actual potash." Run the pencil through everything else. These two terms represent everything of value in that fertilizer. The statement

tells how many per cent of each are guaranteed; that is, how many pounds of each element there are in each one hundred pounds of the fertilizer. If the figure after the words "available phosphoric acid" is 9, that means nine pounds of each hundred in the fertilizer is available phosphoric acid. In other words, one ton of that fertilizer will bring to you one hundred and eighty pounds of that element of plant-food. If the figure "4" stands after the words "actual potash," that means four pounds of each one hundred pounds of the fertilizer is potash, eighty pounds in a ton of it. In this way we learn exactly how many pounds of plant-food is carried to us in a ton of any fertilizer.

\*\*\*

**MARKET PRICES OF THE ELEMENTS.**—The price a farmer should pay for a pound of nitrogen depends upon the character of the material containing the nitrogen and upon freight rates. This is equally true of the other two elements of plant-food. Prices are lower near the seaboard than farther inland. In a ready-mixed fertilizer the farmer west of the Alleghenies makes a fairly close rough estimate of the value of any fertilizer offered him by figuring the nitrogen at three dollars for each one per cent of it, the phosphoric acid at one dollar for each one per cent of it, and the potash at one dollar for each one per cent of it. As the ton is the basis always, one per cent is twenty pounds. That scale of prices is higher than one need pay when he buys the various materials and does his own mixing, it being fifteen cents a pound for nitrogen and five cents a pound for the phosphoric acid and for the potash. The reader understands that the assumption is that the buyer pays cash and does not ask the dealer to keep agents trotting after him for his order, and then for the money.

\*\*\*

**BEAR THIS IN MIND.**—The most of the fertilizer we buy is the "carrier," the material in which Nature stored the plant-food we want. We must know how much of nitrogen, phosphoric acid or potash is contained in this carrier—this so-called fertilizer. Pay attention to only three items—nitrogen (or ammonia), phosphoric acid available, and actual potash. The statement of analysis gives the percentage of each. Figure out the number of pounds of each material in a ton of the fertilizer. Figure up the value of each material, using the true price a pound for your locality. That determines the commercial value of that fertilizer. Its actual value for your soil and crops can be determined only by experiment.

DAVID.

2

### THE RENTER AND THE RENTED FARM

There is something radically wrong in our present system of renting land. The rents are so high that the renter can neither do the land nor himself justice. From the landlord's point of view, too, the money invested in a farm is far from being remunerative when the expenses and taxes are all paid and the profits counted up. While the renter fails to get a just return for his labor, the landlord fails to get a just return for his capital invested. Both sides are working a losing game, and in their effort to get on a paying basis only get farther and farther from their true position—one in which there is money for both tenant and landlord in a rented farm. To make it pay there must be a mutual interest in each other's welfare. A union of interests is the only solution of the problem.

I have two farms in view, both of which have been rented for the past fifteen years. Conditions were equal in the beginning, as was the rent. One third was given by the tenants to the landlords for the use of the land. But the rent in this section began to advance—landlord No. 1 being among the first to put his land up. His tenant, a good farmer and an industrious fellow, saw where he could better himself, and did so. The farm remained unrented until late in the spring, then a man who had failed to get another home took it. That year was the beginning of the degeneration of farm No. 1. Landlord No. 2 had a good thing, was making good interest on his money, and his tenant, too, was getting on in the world. They were on the best of terms, often together making plans so that the farm might be benefited to their mutual welfare. It was understood between them that the tenant was to remain on the farm with no increase of the rent so long as he continued to make it pay both parties.

Tenant No. 2 was never slow to take advantage of such little offers from his landlord as a bundle of trees for the setting out and tending. He felt that he would reap the fruits of his labor and not be working for

some other man. His landlord in spending money on such things felt that he was sure of being benefited, for the fruit-trees were sure to receive the best of care. He, too, furnished fine stock for his farm, knowing that his return would be such as would justify the outlay. He was not slow in acquiescing to the tenant's request for sheds and barns. The buildings were sure to be looked after in the best of manner, and buildings added a value to his farm and also increased the returns from his stock. That farm is to-day one of the best-cared-for farms in the country around. Its tenant is able to-day to buy land of his own, and has, but he still lives on the rented farm, paying his one third rent.

In the past ten years farm No. 1 has not been worked three successive years by the same man. The rent has been advanced until this season no one could be found who would take it, and the owner has attempted to work it himself, or rather send his hired man to work it for him. The barns fell to ruin five years ago. The house has grown worse and worse as the years have gone by, until now no one could live in it through the winter. The land has been literally killed. Every man knew that he was to get nothing but the one crop from it, and not much of that, and have worked accordingly. Although the farm joins my own, under daily notice I have never known of a load of manure being hauled out to the fields. Cockle-burs and noxious weeds cover the fields. The corn last season on neighboring fields made from thirty to forty-five bushels to the acre, but this farm I do not believe averaged five.

The rent was one half the crop delivered at the elevator two and one half miles away. Last year I suppose the rent was raised to three fifths, as the landlord failed to get a tenant. I do not believe the crop last year will more than pay the taxes, and what can be done in the future with the farm is a problem. It is not probable that the owner will attempt to work it himself again, and it is more doubtful if he can find a man to take it at any figures.

These farms are both known to my locality and should be an object-lesson to landlords and tenants alike. But home landlords go on their way, squeezing the last nickel from the tenant, and the tenant goes on his way, skinning the land for the last farthing with the least labor possible. It is not to his interest to set out or tend an orchard or to spend time in more than temporarily repairing sheds and other farm buildings. Moving around from year to year he cannot keep stock. He sells what he sows and reaps—makes a living, but no more.

To make renting pay the rent must be lowered and the standard of the renter raised. The average renter is not capable of running a farm on a paying basis. He is not educated up to it. He may be an honest, industrious fellow, but lacks the mental ability to make his business pay. It is not a lack in natural ability, but the workings of the short-sighted system now prevailing. He has no chance to get ahead and accumulate property. Without planning years in advance no farmer can make his farm pay, and it is out of the question for a renter to plan where he is not sure of the farm he works more than a year ahead. A good farm deserves a good renter, and when one is found a landlord should not hold a penny so close to his eye that it will hide a dollar a short distance away, but make it worth the tenant's while to stay on the farm. With a good farm, a good tenant and a good landlord the problem will be easily solved.

J. L. IRWIN.

2

### CREAMERY-BUTTER MAKERS' ASSOCIATION

The eighth annual meeting of the National Creamery-Butter Makers' Association was held at Lincoln, Nebraska, February 19 to 23, 1900. This meeting was the gathering of the most progressive butter-makers of the Middle West, of the creamery managers and the commission-men from Chicago, New York and other points. The presence of these latter has come to be an important factor in what was formerly a meeting of butter-makers. By far the largest proportion of the butter made west of Chicago is handled by commission-men in one or the other of the great markets. These men meet the men who make the butter, and tell of the needs of the various markets. Chicago, New York, Boston, and in fact each large city, requires different degrees of saltness, different shades of color, and even the size of the package required differs in different markets. The creameryman has learned what some of our farm butter-makers have not, that if the highest price is to be secured for their goods they must make it the way

the market wants it—that is, color, salt and flavor to suit.

The most intense interest was manifested in those papers which touched on the securing of a better grade of milk from the producer, and more of it. These butter-makers were not seemingly so much concerned in how to make good butter from sweet, clean, pure milk, but how to get the milk that is sweet, pure and clean.

I wish I might find words to impress on the man who is making milk for a creamery the necessity of delivering it into the butter-makers' hands in the very best possible shape; then only can he make a butter which will sell for the highest market price. The higher the price of butter, the higher price the creamery can pay for milk.

Butter-makers urged each other to get out among their patrons and study feeding problems; to be teachers, if need be, of how to combine the feeds at hand into better balanced rations. A South Dakota man told of one of his patrons who received last year \$305 for the milk, delivered at the factory, from six cows; another of \$900 from twenty cows. These patrons are careful feeders, and the latter one a great believer in the tank heater as a milk-producer. His original herd was scrubs. This spring he will have twenty heifers, sired by a Jersey, come fresh.

One man advocated the feeding of sour skim-milk to calves, claiming a steady diet of the sour milk was better than to attempt to have it sweet and have it sour every few days, as is the case where milk is hauled home from the creamery.

Alfalfa was recommended to balance up the abundance of corn in the Western ration. It was said that there is less danger of injurious overfeeding when a balanced ration is fed.

In the West silo-filling and harvest come so close, and labor is so scarce and corn so abundant, that as yet the silo is not much used.

Secretary of Agriculture Wilson said the Danes and Canadians buy 16,000,000 bushels of our corn and \$155,000,000 worth of oil-meal, to help make the butter with which we must compete. For export purpose cotton-seed meal in the ration makes a hard, firm butter. He urged the dairyman to take advantage of beet-pulp as feed for dairy-cows, when situated where it can be had, saying that sugar-beet production and dairying go hand in hand.

Commerce wants the carbohydrates from the sugar-beet, cotton-seed and flaxseed, leaving a high per cent of protein in the by-products, pulp and meal for the use of the dairyman.

Prof. T. L. Harcher, of Minnesota, gave a very vivid explanation of the variation noted in testing milk, quoting data from careful observation to show that much of it is due to the variation of fat yield by the cow at different milkings.

Butter-makers were urged to take every opportunity to explain to their patrons the principles and practice of the Babcock test, that they may understand that the variation is caused by the cow rather than by manipulation of the test.

E. S. Snively, of the Beatrice Creamery, located in Lincoln, described the advantages of the skim-stations. Their creamery has one hundred and five stations where milk is received, and the cream sent to the central plant to be churned. Some of it comes over four hundred miles; that is, the whole length of the state.

Prof. H. L. Russel, of Wisconsin, gave an illustrated talk on bacterial infection of milk. His pictures illustrated the large number of bacteria which fall into the milk-pail during the process of milking cows, emphasizing the necessity of brushing the cows, and particularly the udders, before milking. He called attention to cracks in the utensils as harbingers of germs of putrefaction.

Over seven hundred tubs of butter were on exhibition in the display-room.

The prizes went as follows: On separator butter—First, H. T. Sondergaard, Litchfield, Minnesota, score 98, solid gold medal and \$100 in cash; second, Martin Mortenson, Willow Creek, Iowa, score 97½, silver medal and \$50 in cash. Gathered cream class—First, M. Magnusson, Bee, Minnesota, 94, solid gold medal; second, R. A. Carpenter, of York, Nebraska, 93, silver medal.

In addition to these cups were awarded to the highest score in each state having twenty or more entries. Ohio and Indiana each had some entries, but not enough to compete.

A monster parade in which the visiting creamerymen and commission-men were joined by the students of the Nebraska University and the Lincoln Fire Department was an interesting feature of the program.

VAN.



## NOTES FROM GARDEN AND FIELD

**C**ATALOGUE LEAVINGS.—“Vick's Garden and Floral Guide” appears in a handsome cover, showing a group of clematis on the first, and a group of pansies on the last page. This firm pushes flowers and flowering plants to the front, as indicated by the fact that the vegetable department finds the unusual place of the back part of the catalogue. Like many of our best seed-catalogues it gives mostly photographic reproductions of vegetable varieties, and while for that reason there is little in it of a sensational nature, it tells a truthful story in an interesting way. I always feel that I must speak commendingly and encouragingly of the practice of making use of the camera in giving illustrations. Among the novelties the Vicks give the Twentieth Century cabbage as the earliest of all, Royal lettuce, and Bright and Early tomato, claimed to possess the best combination of earliness, yield and quantity yet attained in this vegetable. This catalogue also offers a prepared Bordeaux mixture, such as I speak of in another column, and likewise the Rochester sprayer, costing \$4.50. Agents have sold a good many of this style of sprayer in this part of the country the past winter. I was urged to buy one, too; but when I have to carry a load of spraying liquid through potato-fields or among grapevines, young trees, etc., I would rather carry it on my back, knapsack fashion, than hanging from the hand like a water-pail. The load is heavy to make the best of it, and in operations of even modest extent we must find the most convenient and least tiresome way of carrying it.

The catalogue of F. B. Mills, New York, is more extensive than is indicated by its weight, as the paper is thin and rather poor. It gives a number of new tomatoes, and offers a prize of \$50 each for new names for certain novelties. Since Henderson & Co. offered such a prize for naming the tomato now known as Ponderosa it has become quite a common practice of seedsmen to offer such rewards. Of course, this proposing a name is much like buying a lottery-ticket—few prizes and many blanks—and the most meritorious do not always win. Mr. Mills still offers “Mills' Earliest tomato in the world,” which is a good early tomato, I believe one of the best very early ones we have, and good enough to deserve the good plain name, “Mills,” or “Mills' Early,” and this name I invariably use when mentioning it in my writings. The same catalogue also offers the “Giant Everbearing” tomato, and prizes for specimens weighing three pounds, two and one half pounds and two pounds respectively. The “Vine peach” or “Mango melon” named in this and other catalogues does not amount to much in my estimation. It is neither ornamental nor useful. The “Chinese lantern-plant” should find a place among ornamental plants rather than among the vegetables, for it is not productive enough to pay growing it for table use. The root is hardy, and where once planted, as, for instance, in a border or flower-mound, it is liable to spread all over, and send up new sprouts here and there, blooming and fruiting sparingly. I saved some of the husk-covered fruit and used them as ornaments on the Christmas tree. One of Mills' colored plates shows American ginseng, both in single plant and as grown in beds under lattice shading. Altogether this is a catalogue that it will pay us to look through carefully, even if some of the statements have to be taken with a grain of salt.

From Massachusetts comes the old reliable catalogue of James J. H. Gregory & Son. It runs mostly in vegetable lines, Mr. James J. H. being known far and near as a skillful gardener and recognized authority on the cultivation of vegetables. I do not remember ever having seen an overdrawn picture in Gregory's catalogue. In fact, he uses illustrations quite sparingly, but his gradual change to photographic reproductions is pleasing to me, nevertheless. It was this catalogue which first stimulated my interest in vegetable-gardening to the point of enthusiasm, and started me in this line of occupation. Early Ohio and Burbank potatoes, I believe, were introduced by Gregory in 1870 or 1871, if my memory serves me right. Some of the excellent books on the culture of vegetable crops, from the pen of Mr. Gregory, were among the trusted guides in my earlier garden operations. Among the season's novelties I notice Maximum lettuce, claimed to be the largest and most

solid of all our head lettuces, and perfect in quality; also an Improved Large-leaved water-cress; an African Horned cucumber; the Diadem tomato, a striped variety; the Early Bird tomato, etc.

No greater color display has ever been made by any seed-catalogue than found in that of John Lewis Childs. This used to be the yellowest kind of a “yellow journal” in seed-catalogues. As in other publications of its class, I think I can notice in it a gradual toning down and decrease in its more sensational features, so that the catalogue to-day is quite acceptable. It would be worth having if for no other reason than its many beautiful but high-colored plates. The Gaillardias, a group of which appears on one of these plates, are strikingly beautiful in the picture, as they are in nature. These plants are easily grown, and when once planted add life, brightness and gay color to your bed year after year. Mr. Childs' catalogue gives prominence to ornamental plants and flower-seeds over vegetable-seeds. I notice that he classes the “Alpine Everbearing” strawberry with the ornamentals, offering seed which he says will produce plants freely and fruit the first summer and fall. I have never tried them in this way, but find the Alpines so shy to bear fruit that I am inclined to think the position of the plant among ornamentals is the correct one. It is more fragrant than taste that we get of them, and yet I continue to keep quite a patch of them on account of the pleasing spicy flavor of the berry, even if I am unable to get the quantity. A reader recently asked about the “Goliath” kohlrabi. Childs' catalogue offers a “Late Giant” as a sort of enormous size, growing to weigh twenty pounds, yet tender and fine. Of course, Mr. Childs offers the “Tree” strawberry or “strawberry-raspberry,” the Golden Mayberry, the Japanese wineberry, the Loganberry, also a new balloonberry. My plants of the Mayberry and strawberry-raspberry have succumbed to our climate after making some feeble growth for a year or two. I do not concede to them any practical value. The Loganberry is still alive, and I hope may give me a little fruit this year. But that picture of the Childs' “Everbearing Tree” blackberry should be eliminated from the pages of the catalogue. It is not a credit to it, as this blackberry is a branching sort, like all others.

Among nursery catalogues I have Young's fruit list. For a cover page I cannot perceive of anything more attractive and more tasty than that modest fruit and flower picture on the first page, which presents objects as they are. It is a gem indeed. I was under the impression that I once received the Walther Peas apple from this firm, but I do not find this variety mentioned in the catalogue. Of course, they have the Gravenstein apple, as also the Duchess of Oldenburg, the latter an early fall apple which I find very valuable and profitable. The tree here seems to be almost the only one that is proof against the apple-scab. The foliage has always remained in perfect health and thrift, of a beautiful dark green, when all other varieties around it were badly affected with the scab. In this fruit list I also find the Columbus, the Red Jacket, Industry, Keepsake and other good English gooseberry sorts.

T. GREINER.

### INQUIRIES ANSWERED

BY T. GREINER

**Best Fertilizer.**—J. S., Cooncreek, Minn., writes: “What is the best fertilizer for general purposes?”

REPLY:—Much has been said in recent issues on the question of selecting fertilizers for various soils and crops. I can only answer that the best fertilizer for general purposes is the one which furnishes to the soil that element, or those elements, in which the soil is most deficient. Potash and superphosphate (more potash on sandy soils, less on heavier loams), with clover or other leguminous crops, will usually or invariably give good results.

**Earliest Tomatoes.**—R. S., Mercer county, Illinois, one of our readers, asks me whether Early Ruby, Atlantic Prize and Early Leader are one and the same tomato. No. The Leader is surely different from the Ruby, and the Atlantic Prize, if I have a correct picture of it in my mind (I have not grown it for many years), is different from both. Leader is too small, and all are rather irregular. I do not grow either of the three any more. Another subscriber, F. E. L., Dorchester county, Maryland, asks me whether the Maule's new tomato (1900) is an early one. I do not know. I got seed late last year, and my plants, therefore, were late, and gave later fruit than plants started earlier. But try it and see.

**Establishing a Retail Vegetable Trade.**—A. L. S., Orwigsburg, Pa., writes: “I am anxious to know how to establish town trade for

market-garden and dairy products. What kind of fertilizer is best for red-shell soil for garden produce? Which is the most economical, for me to retail my produce or sell wholesale?”

REPLY:—Grow good garden stuff, and keep cows that give good milk. Then secure a nice market-wagon tastily painted, a good horse or team, bright harness, etc., and if you are not a good salesman yourself, hire a man that is and whom you can trust. Then put him on a route and let him establish a trade. The quality of your products will bring you trade and permanent customers if you know how to treat them well and honestly. After your route is well established you or any one else can run the wagon, and you will soon find out which is most profitable for you and your conditions, to sell at wholesale or retail. I try to retail as much as possible. As to garden fertilizers read the articles appearing from time to time in the FARM AND FIRESIDE.

**Commercial Value of Novelty.**—H. L., Millersburg, Ohio, writes: “I have a white-seeded, round-podded and stringless wax-bean which has been tried and tested by a seed-house, and who now want to buy all my seed of it and the control of the variety, but want me to set the price. Since I never had anything of this kind to sell before I do not know what to ask for it, and ask your advice. What do you think the beans are worth, giving complete control of same?”

REPLY:—I have had letters of a similar nature repeatedly, but do not feel that I should take upon me the responsibility of appraising any novelty. The commercial value of a new vegetable depends altogether on the chances it has for becoming popular and finding large sales at good prices. Mr. Burbank, if he creates a new valuable plum, could probably sell a single tree, with the control of the variety, for \$1,000 or more. So it is with vegetable novelties. If I had a really good new thing I would first of all try to get a good stock of it, and in the meantime let the experiment stations test it and report on it, also show it to as many large seedsmen as possible, and then sell it to the highest bidder. A variety is worth what it will bring in an open market.



CONDUCTED BY SAMUEL E. GREEN

### CRANBERRY NOTES

The number of commercial growers in the United States is over two thousand. They are found mainly in the states of Massachusetts, New Jersey, Maine, Connecticut, Michigan and Wisconsin, but Minnesota, Oregon, Rhode Island, Washington and New York reported bogs. The number in Michigan and Wisconsin is on the increase, despite a temporary set-back by forest-fires.

There are many varieties of cranberries. Over one hundred of them of good keeping and shipping qualities were raised at the state experiment station, at Madison, Wisconsin, in 1898, and exhibited at the succeeding cranberry convention. The United States consular officers report about an equal number in the Canadian provinces, the best of which are being transplanted to this country.

The growers are well organized, the national association having its headquarters at Trenton, New Jersey, and local organizations existing in Massachusetts and possibly elsewhere. They keep a record of acreage and production, and gather for their own use certain annual statistics. They are also attempting to secure the adoption and common use of barrels and crates of uniform size, sanctioned by law. What is known as the “Western barrel,” so fixed by law in Wisconsin, is twenty-five and one half inches high, sixteen inches in diameter at the heads, and eighteen inches in diameter at the bilge, inside measure, and must be officially branded, under severe penalties for failure.

The Massachusetts or Cape Cod barrel is slightly different, being sixteen by seventeen and three fourths by twenty-six and one eighth inches, inside measure, and must contain one hundred quarts.

The Wisconsin (legal) or Western crate is twenty-two by twelve by seven and one half inches, inside measure, and must be branded. The Cape Cod crate, in use also in Connecticut, Maine and New Jersey, is of the same dimensions.—From United States Census Official Report.

### INQUIRIES ANSWERED

**Fodder Corn in Young Orchard.**—J. R. G., Brownsville, Tenn., writes: “Having a cow to feed and hogs to fatten, what crop shall I raise in a young orchard?”

REPLY:—I know nothing better than corn fodder, but the soil should be carefully cultivated and well manured to keep up its fertility.

**Spray for Apple-worm.**—D. D. D., Pierce, Pa., writes: “What is best to prevent worms in apples? What spraying liquid should be used, and at what time?”

REPLY:—Spray with Paris green and water at the rate of one pound to one hundred and twenty

gallons of water, first after the flowers fall, and repeat again in two weeks.

**Curculio.**—H. B., Staffordville, Ky. I think the injury to your apples that you complain of is probably caused by the apple-curculio. It may be largely prevented by spraying the fruit with Paris green and water early in the spring. In the Western and Middle states knotty apples frequently occur from this cause, but I am not sure about this insect occurring in Connecticut, and would suggest that you write to your state experiment station, at Storrs, in regard to it.

**Mildew on Currants.**—W. F. C., Mazomanie, Wis., writes: “What is the cause of my currants mildew? Mildew starts soon after currants set, yet they grow to full size and ripen. The land lies facing the east, and is well drained.”

REPLY:—It may be that they are so protected that they do not dry off quickly enough. You can probably prevent it on both currants and gooseberries by spraying with liver of sulphur (potassium sulphid) at the rate of one ounce to the gallon of water. Apply this as soon as the leaves appear, and once in two weeks thereafter.

**Scurfy Scale.**—J. H., Kratzville, Pa. The piece of pear limb which you inclose with small white scale on it is infested with what is known as “scurfy scale.” This is not so injurious as many kinds of scale, but it is undoubtedly harmful to the tree. The best remedies for it are spraying the trees in the spring, before the buds open, with a strong alkaline wash made with potash and water. Kerosene and water sprayers are also effective.

**Cherries Falling.**—H. W. G., Harmony Grove, Ga. I think that spraying will not prevent your cherries from falling. The trouble is probably lack of proper pollination of the flowers, which can only be supplied by planting other varieties in your orchard. I could answer this matter much more intelligently if you would give me the name of the variety of cherries you have, and tell me whether the fruit seems to be rotten or to have worms in it when it falls.

**Evergreens.**—C. W. D., Lerado, Kan. Evergreens best suited for Kansas are probably the Scotch and Austrian pine, of those commonly grown in nurseries, and of our native trees, the Bull-pine and the red cedar, which are found in the foothills of the Rocky mountains, probably in Kansas, and have wonderful drought-resisting qualities and are long-lived. The Bull-pine is rather difficult to transplant when of large size, and on this account should be obtained when not over one foot high. It should be grown from seed grown on the eastern slopes of the mountains, where the climate is dry, since this tree is much harder when taken from this section than when they come from the Pacific slope. Rev. C. S. Harrison, of the missionary school, at Weeping Water, Neb., has made a specialty of collecting these evergreens in the mountains and selling them for the benefit of his school. I think you will find him a good person to deal with. He can supply the Platte cedar, which is a very hardy form of the red cedar.

**Pruning Trees—Borers—Mulching.**—A. J. P., Haynesboro, Va., writes: “I have an orchard of young trees. Is it right to prune off all the branches when the trees are first planted? When is the proper time to prune my young trees—spring or fall?—What shall I do to prevent borers getting to my trees, and what will destroy them after they get in the trees? Is it right to clear all trash from around the trunks of the trees in the fall?—Should trees be mulched during the summer months? Is bog manure good for peach trees?”

REPLY:—In the case of peaches all the side branches should be cut off. In the case of apples, pears and plums, shorten the new wood to correspond with the loss of roots, and cut off awkward and useless branches.—See reply to inquiry in this issue.—It is best to keep all grass from around trees, both summer and winter. It is better to cultivate the land thoroughly and keep the surface loose all summer than it is to mulch.

**Borers.**—A. C. S., Rockwood, Pa. 1. There is no known satisfactory remedy that will keep the borers out of the trees. The washes which have been recommended either fail or require as much or more work than the digging-out process, and the latter is much more satisfactory in the end. The trees should be looked over in the late spring, midsummer and in autumn, and the worms dug out. Some of the washes recommended are liable to destroy the trees. The most exhaustive experiments along this line are those made by Cornell University and published in a recent bulletin on the peach-borer. In these experiments various kinds of washes were used, and some of them kept out from one half to two thirds of the borers, but none were more satisfactory than digging out, or much, if any, less expensive. White lead and oil was about as satisfactory as any wash, except that it was found to be liable to injure the trees. Tobacco-stems tied around the trunks seemed a very good and cheap deterrent. 2. I do not know whether it is a good plan to slit the trunks of young trees, except that in the case of cherry-trees that become stunted the bark sometimes binds so tight as to cut off the circulation of sap, and then slitting the bark is a great advantage. Last summer I visited Luther Burbank at his home in California. He is a very keen horticulturist, and I found he had slit the bark of most of his plum and cherry trees. In reply to an inquiry he said that when he first came to California he laughed at his neighbors for practising it, but he had become convinced that it is a good thing to do in that climate. I do not see how it can do any harm. 3. The age at which trees come into full bearing varies greatly with varieties and section of the country. In your section, perhaps when ten years' old apple-trees could be depended on to bear good crops if they are well cared for.



# 6 BEAUTIFUL ROSES FREE

To introduce our popular and interesting family paper, The Illustrated Companion, into 100,000 new homes where it has not already been taken, we make this Grand Offer: Upon receipt of only 25 cents, we will send The Illustrated Companion the rest of this year (10 months) and six lovely ever-blooming roses FREE, all charges prepaid, as follows: The Bride—A beautiful pure white rose, handsome double flowers. This is a new variety and the best white rose ever offered the public. Queen of Fragrance—Another new white rose, sometimes edged with shell pink. It is the most fragrant rose known. Its delicious perfume will fill the whole yard. Papa Gantier—A grand red rose, crimson shade, silken texture, bud elegant size and form, long stems with beautiful dark and heavy foliage. Champion of the World—A prolific bloomer, each shoot is loaded with flowers from early Spring until frost. Color, rich glossy pink, very fragrant. Comtesse de la Barthe—This rose combines exquisite perfume with matchless profusion of flowers. Color, soft light rose, with shading of amber and salmon. Mademoiselle Francisca Kruger—A strikingly handsome rose, both in bud and full bloom. Color, deep coppery yellow, making it unique and distinct from all others. Flowers good size and symmetrical. Understand, we offer the entire list of six ever-blooming roses as described above absolutely FREE by mail, prepaid, if you will send us 25 cents for The Illustrated Companion the rest of this year (10 months) March to December. You will get full value in the paper, the regular price of which is 50 cents per year. The roses are an absolutely free gift to people who answer this advt. These roses are not the cheap, common sort, but are the most choice selection of modern roses. They are all well rooted, strong, healthy and will bloom this year. They are grown for by one of the largest and most reliable growers in this country and each bush would cost you of a Floriculturist 25 to 50 cents. Warranted true to name and to reach you in perfect condition. Understand, we offer the opportunity to receive this advt. will be given the opportunity to receive FREE either a grand 56-piece Tea or 52-piece Dinner Set, you to make the choice. The Illustrated Companion is a large 64-column family journal, containing handsome line and half-tone illustrations, with descriptions of various places, events of interest, also serials, short stories, humor, etc. You will be delighted with the paper, and the roses are worth many times the amount you pay; besides you may get a lovely Tea or Dinner Set FREE. They are full size for family use. We guarantee complete satisfaction or money refunded. Our publication is 21 years established. As to our responsibility, we refer you to the mercantile agencies or the leading newspapers. THE ILLUSTRATED COMPANION, 296 BRO ADWAY, NEW YORK. DEPT. 85.

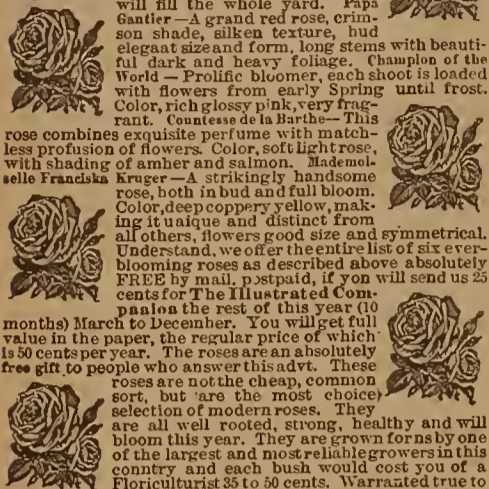

Furthermore, to one person in each town who answers this advt. will be given the opportunity to receive FREE either a grand 56-piece Tea or 52-piece Dinner Set, you to make the choice. The Illustrated Companion is a large 64-column family journal, containing handsome line and half-tone illustrations, with descriptions of various places, events of interest, also serials, short stories, humor, etc. You will be delighted with the paper, and the roses are worth many times the amount you pay; besides you may get a lovely Tea or Dinner Set FREE. They are full size for family use. We guarantee complete satisfaction or money refunded. Our publication is 21 years established. As to our responsibility, we refer you to the mercantile agencies or the leading newspapers. THE ILLUSTRATED COMPANION, 296 BRO ADWAY, NEW YORK. DEPT. 85.

**WHY Can we Save You Money** on a vehicle, harness, fly net or saddle?

**Because we have no agents.**

Can we really do it? We say yes. Can we prevail without cost to you? We can. How! We will ship you a harness, saddle, or vehicle, without you sending a single cent, and let you look it over at your freight house and if you don't find it we have given you the biggest bargain you ever saw or heard of, return the goods to us at our expense. We give with each vehicle a 2-year iron-clad guarantee, protecting you from poor material and workmanship. Our vehicle catalogue describes the largest line of huggies, road wagons, phaetons, snarries, spring wagons and carts, harness, fly nets and saddles ever shown in one book. It's free. Send for it. Marvin Smith Co. 55-59 N. Jefferson St. U-26, Chicago, Ill.

**FARMERS** Send for a large Catalogue of the celebrated "DeLoach" VARIABLE FRICTION FEED Saw-Mills, Shingle-Mills, Planers, Hay-Presses, Grinding-Mills, Water-Wheels, etc. Our Saw-Mill is warranted to cut over 2,000 feet of board lumber in ten hours with 4-horse power. Prices low, and we pay the freight. DeLOACH MILL MANUFACTURING CO., 300 Highland Avenue, Atlanta, Georgia.

**AUTOMATIC WEEDER AND CULTIVATOR.** No Straight Frame Equal to It. A time, labor and money saver. Kills all weeds on any kind of crop—any kind of land. Splendid for wheat fields in spring—makes it stool out perfectly, increasing yield. (Cuts 7 ft. wide or narrow 3 1/2 ft.) Works 2 acres per hour. All teeth best oil tempered steel. Cash price \$7.20. Freight east of Mo. River and north of Ohio River only 25c to 75c. Write for big free catalogue of Implements, Buggies, Sorreys, Road & Spring Wagons, Harness, &c. Cash Supply and Manuf'g Co., Dept. B, Kalamazoo, Mich.

**Soon Saves Its Cost. A 12-Year Old Boy** can do more and better work, either in the field or garden, with the **HAND CULTIVATOR** than three men can do with common hoes. Plows, hoes, cultivators—astute or common rows. If no agent in your town send \$1.35 for sample delivered and terms to agents. Ulrich Mfg. Co., 43 River St., Rock Falls, Ill.

**We Want AGENTS For The ECONOMY HARNESS RIVETER** And Other Fast-selling Articles. The riveter can be used in any position. Mends anything where a well-clinched rivet serves the purpose. For heavy farm work. Can be carried in the pocket. Agents make \$3 to \$15 a day. Send 50c. for sample, loaded with 50 rivets, and TERMS TO AGENTS. J. D. FOOTE CO., Fredericktown, Ohio.

**BOYS & GIRLS** Men and Women—Watches, Cameras, Air Rifles, Skates, Rings, Jewelry, Silverware, etc. FREE for selling 20 packets of our PREMIUM FLOWER SEEDS at 10c. each. No money in advance—Send name and address and we mail you 20 packets with premium list and instructions. When sold send us the \$2.00 and we will forward the premium you select. Don't miss this grand opportunity. Write for outfit to-day. Address, WESTERN SEED HOUSE, 7 Hill St., Maywood, Ill.

**Steel Wheels** Staggered Oval Spokes. BUY A SET TO FIT YOUR NEW OR OLD WAGON CHEAPEST AND BEST way to get a low wagon. Any size wheel, any width tire. Catal. FREE. Electric Wheel Co., Box 96 Quincy, Ills

**Steel Wheels for FARM WAGONS** Any size wanted, any width of tire. Hubs to fit any axle. For catalogue and prices write Empire Manufacturing Co., Quincy, Ill.

**FOR SALE** Large quantity of HARRISONS. Formerly retailed at \$20 apiece. Will sell at \$10 each f. o. b. B. B. OGDEN, Keeyport, N. J.

**A SAFE FUSE**

**T**HE use of explosives for the removal of stumps, stones and other obstructions upon farms seems to be gaining in popularity. Probably the methods would become more popular were it not for the fear of accidents. It must be admitted that there is considerable risk in this work, but it seems that the greatest is in the fuse—the rate at which it burns. With ordinary fuses as purchased one seldom knows how fast or how slow they will travel, and even by testing little can be known of the remainder of the ones purchased; they may burn slower or faster than the ones tried. Besides, the purchaser dislikes making trials that seem worthless and only expensive. With gunpowder fuses, the ones ordinarily used, the difficulty is that they may fail, besides being expensive.

When a young man I was interested in the manufacture of amateur fireworks for Canadian holiday celebrations, and found the recipe given below perfectly satisfactory and reliable. The only objection I then had to it was that it was too slow. Time has cured me of that boyish impatience, however. Its slowness appeals to me now as its best recommendation to the farmer, for whose benefit I give it.

In some water dissolve as much saltpeter as can be made soluble in it, and soak some candle-wicking or common, coarse white twine in the solution. Do this soaking thoroughly, so that every particle of the string is wet. Remove, squeeze out the excessive water, and hang in the sunshine or a current of warm air to dry. Don't try to dry it over the stove. No serious results would follow if you did, only the burning up of your material and the loss of your time should the stuff take fire, which it will do if it gets too hot. I tried this once, and—well, the stuff burned up and I had to do my work over. When thoroughly dry test it by lighting a piece. Take your watch and see how long it takes to burn a given length, or how much will be burned in a given time. As nearly as I can remember mine burned about ten inches a minute. The rest that you make will burn at the same rate, provided it be made from the same solution.

I have made and used several hundred feet of this fuse and have never known it to go out in the most violent wind or under any ordinary circumstances so long as it was kept dry. It is slow, safe and sure, and better, it is cheap. Five cents' worth will be enough to blow up all the stumps on your farm. M. G. KAINS.

**TAKES THE CAKE**

The man who "takes the cake" nowadays is the man who takes a cake of oil-meal and distributes it in his feeding ration. This is a cake about which there is no fake.—Home-stead.

**WORDS are seeds; like oats they scatter** rust and blight—you ought to soak your oats in formaline, and soak your words in thought. Rural New-Yorker.

**CORRESPONDENCE**

**FROM ARKANSAS.**—Brightwater is lively, and business good. We think we have the nicest place to live in there is in the state—the best water, the most picturesque scenery, the best-behaved boys and the prettiest girls. This town once heard the roar of the cannon and saw the clash of arms in a deadly conflict, but it is all peace now. The old breastworks stand on the mountain-side north of the town, thrown up there by General Siegle's Dutch boys. The gentle old cows crop the clover that grows out of the rifle-pits. Instead of the rattle of muskets and the scream of the bomb-shell singing can be heard in the little white church. Everybody seems to be at peace with his neighbor. The common wood-chopper and the man with broad acres and grand piano associate together. This place is famous for the interest manifested in music. There are orchards and strawberry-fields everywhere. The hillsides, though rocky, are rich, and especially well adapted to fruit-growing. Land is cheap. Brightwater, Ark. J. B. P.

**FROM WASHINGTON.**—I would advise any man who has a fairly good job, or a farm where he is making a fair living, to let good enough alone. Sawmills and logging-camps only run steady during the summer months. As it rains here about seven to eight months in the year, out-of-door work is not very pleasant. In the eastern part of the state land sells at from \$35 to \$200 an acre, and has to be irrigated, which costs \$1.25 an acre a year. Fruits, wheat and hops do well, but the freight rates eat up the profits. There is land advertised for sale at \$1.25 an acre, but there is no water or irrigation canals on it, and without water it is of no value. Western Washington has too much rain for wheat-raising, and the nights are too cool for wheat and corn. Vegetables do well here, but the business is in the hands of Chinamen and dagoes, and they have run prices down. Seattle, Wash. A. P.

**1900 "ALPHA-BABY" CREAM SEPARATORS**

Great as has been the previous superiority of the "Alpha" De Laval machines to other separators, the 20TH CENTURY "Alpha" developments place them still further above the possibilities of attempted competition from anything else in the shape of a cream separator.

**NEW STYLES, CAPACITIES AND PRICES.**

Old Style "Hollow-Bowl" Baby No. 1,	150 lbs.,	- \$50.00
Old Style "Strap" Humming-Bird,	175 lbs.,	- 50.00
Improved "Crank" Humming-Bird,	225 lbs.,	- 65.00
Improved Iron-Stool Baby No. 1,	325 lbs.,	- 100.00
Improved Iron-Stool Baby No. 2,	450 lbs.,	- 125.00
Improved High-Frame Baby No. 2,	450 lbs.,	- 125.00
Improved High-Frame Baby No. 3,	850 lbs.,	- 200.00
Improved Dairy Steam-Turbine,	850 lbs.,	- 225.00

Send for "20th Century" catalogue.

**THE DE LAVAL SEPARATOR CO.**

RANDOLPH & CANAL STS., CHICAGO  
General Offices: 1102 ARCH STREET, PHILADELPHIA.  
74 CORTLANDT STREET, NEW YORK.  
103 & 105 MISSION ST., SAN FRANCISCO.  
327 COMMISSIONERS ST., MONTREAL.

**Hallock's Success Anti-clog Weeder and Cultivator**

WHAT DO YOU THINK OF THIS REPORT?

Please accept thanks for your kindness. You appear to be the most liberal manufacturers we have ever dealt with. We wish to say that this is the third year we have used your weeder, and we are very much pleased with it. We used it for corn, potatoes, tomatoes, cabbage, etc., with wonderful results. We had a good two-horse cultivator at the time we bought your "Success" Weeder, and we state truthfully that we have not used the Cultivator since, as one small horse and your weeder will do more and better work than two teams and cultivators. The teams, of course, can be used for other work, which means a big saving. Yours truly, J. E. GRAY & SON.

Can you afford to farm without one? Very low price for introduction.

**D. Y. HALLOCK & SONS,**  
Lock Box 830. YORK, PA.

**WE SELL VEHICLES AND HARNESS**

At Less Than Wholesale Prices.

When you buy any of these things you want to feel assured of several facts. First, that you are getting the best procurable quality. Then, that the style and finish are modern and up-to-date, but above all that the prices are right. We are in a position to **GUARANTEE ALL THESE QUALITIES.**

Indeed, we are so firmly convinced of this fact that we will ship our goods anywhere, subject to the most rigid inspection of the buyer. If not found exactly as represented and entirely satisfactory, goods may be returned at our expense. We offer you large selection, many styles of vehicles and many styles of finish. Write today for free illustrated catalogue.

**KALAMAZOO CARRIAGE & HARNESS CO., Box 86, Kalamazoo, Mich.**

**DOES THE WORK BETTER THAN HENS.**

**OUR INCUBATORS** are scientifically perfect, a 200 size hatching more chicks than 20 hens and at a time when sitters are hard to get. As money makers, no apparatus will equal a **Successful Hatcher.** We are the largest exclusive manufacturers of standard incubators and brooders. Send 6 cents for our 150-page Catalogue, printed in 5 languages. Address, DES MOINES INCUBATOR CO., Box 61, DES MOINES, IOWA.

**FERTILIZERS—FROM FACTORY TO FARM**

WE SELL YOU DIRECT. NO AGENT'S PROFITS. NO SALESMAN'S EXPENSES.

**VALUABLE PREMIUMS GIVEN FREE.**

For premium list, prices, samples and book, write

**THE SCIENTIFIC FERTILIZER COMPANY, HERR'S ISLAND, PITTSBURG, PA.**

**YOU CAN EASILY EARN**

bicycles, sewing machines, house furnishings, ladies' or gentlemen's watches, cameras, mandolins, guitars, violins, silverware, dinner sets, guns, and your choice of a hundred other articles, all guaranteed. Simply sell a few boxes of our unexcelled toilet soaps and any of them are yours. Send no money. We trust you. Girls and boys do as well as older people. Write at once for full information. We mail handsome illustrated catalog free. Address Great Northern Soap Works, 92 Lake St., Oak Park, Ill.

**HARRISON'S PEACH TREES** and Strawberry Plants by the hundred or million. We yield to no one in varieties and quality of stock. Ask about Victor Peach and Strawberry Plants, Apples, Asparagus, etc. Illustrated Catalogue mailed FREE. Box 28, Berlin, Md.

**The ROCKER WASHER** I DO THE WASHING WHILE YOU SIT DOWN AND ROCK ME

WARRANTED to do the family washing, 100 PIECES IN 1 HOUR. No need for washboard; no wear on clothing. Write for special prices and description. **ROCKER WASHER CO.** 200000 in Use. Clinton St., Ft. Wayne, Ind. Liberal inducements to live agents.

**OIL MEAL** [OUR OLD] THE VERY BEST Feed for fowls, etc. Health, strength and productive power to animals. Are you feeding it? Cheapest feed in the market. For Oil Meal or Linseed Oil and White Lead, ask for "Thompson's," or get circulars and prices. Thompson & Co., 509 W. Diamond St., Allegheny, Pa.

**NORTHERN-GROWN SEED-POTATOES...** Hammond's Wonderful, White Mountain, Bovee, E. May, Enormous, Sir Walter, 20 others; seed-corn and oats. Circular free. I. E. P. WATSON, FREDONIA, N. Y.

**GREGORY'S SEEDS** For 40 years the favorite with practical gardeners and florists. The new 1900 catalogue describes all varieties. Send for it. J. J. H. GREGORY & SON, Marblehead, Mass.



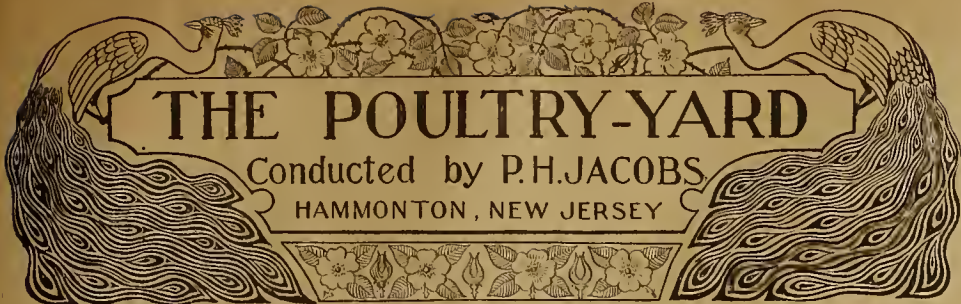

## THE REAL PROFIT

**H**ow much profit a hen gives is governed by the prices obtained; but it is easy to discover which is the most profitable when we base the estimate upon what she daily produces, for no matter what the market value of an egg may be, it contains the same amount of nutrition and calls for the same service from the hen. If a large hen and a small one eat the same amount of food and are of the same age, the large hen has been the more profitable, for the reason that in addition to laying eggs equal in number to the other she has also produced more meat in her carcass when she is killed and dressed. But the service of the hen cannot be estimated by the number of eggs she lays. A hen may lay a greater weight of egg than another, and yet not come up in number to her mates, and therefore, though not giving as large a profit (as eggs are sold by the dozen instead of by weight), she is really more valuable than the apparently profitable hen, so far as true merit is concerned. We cannot estimate how much food is required for a hen for that reason, as some hens lay more eggs than others, some lay heavier eggs, and some do not lay at all, yet food is required for them. It is doubtful if any person can arrive at a knowledge of the actual average cost of an egg, but it is an easy matter to learn if the production of eggs is equivalent to the value of the food given. Something must be allowed, however, for the saving of the waste material used by the hens, as it really possesses no value, but which is picked up by the hens and converted into eggs. The value of the manure is always an item of profit. The cost of the maintenance of the roosters is of course to be classed somewhere, for while the males produce nothing but their bodies, yet they must also be paid for in some shape. All of these matters enter largely into the poultry account.

## MAKING THE CAPITAL

When one has had no experience he should begin at the lowest expense and the least risk. If the capital is small it is better to rent for a year or two rather than buy a farm, because if one buys he reduces his working capital, and should he be unsuccessful he must stay on the farm until he can sell it. If he rents he can return the farm to the owner, and leave. It is claimed, however, that if one buys he can begin and get everything ready for a permanent stay, which is true; but that is just what an inexperienced person should not do. He should start in a small way and make his capital by increasing his flock every year, and by the time he has a larger number of fowls he will know much more than when he began. He can then take his fowls to a purchased farm and feel that he has made a good beginning. That is one point in favor of poultry—the making of capital. No one should expect much for the first two years. Allow five years, begin with but little capital, let the fowls increase, and in five years one may not have made much money for his pocket, but if he will figure up what he has done he will find that he is considerably richer, and has saved his capital instead of taking the risk of losing it all at once. Nothing on a farm pays as much as poultry if rightly managed. But there is no quicker way to lose money if one does not know what he is doing.

## GROWTH OF BROILERS

The supposition that Brahma chicks grow faster and weigh more than Leghorn chicks is true only to a limited period. For the first six weeks of growth the difference in the weight of Brahma and Leghorn chicks is not half an ounce. When ten weeks old the Brahmas may average one and three fourths pounds each, and the Leghorns one and one half pounds each, which is a very small difference in a ten-weeks' growth. Crosses of the Leghorn on Brahmas and Plymouth Rock hens give chicks that weigh only two ounces less than Brahmas or Brahmas crossed on Plymouth Rocks. The comparison is regarded as a very favorable one for the Leghorns, especially as they have been underrated as a suitable breed for producing broilers.

## PROFIT AND PLEASURE IN POULTRY

The majority of those who keep fowls for pleasure endeavor to have the pure breeds and to conform them to the standard, but it does not indicate that because a bird is well marked in plumage, and otherwise beautiful, it is the best for utility. Those who keep poultry for pleasure only should credit the amount of pleasure derived (if such could be done) on the balance-sheet; but those who keep poultry for profit must not always expect too much pleasure. There is at times some hard work to do, and with practical persons no moments can be lost, hence the safer mode is to disregard the outer markings and breed for prolificacy and vigor, though many beautiful birds are sometimes the best to be had. Pleasure should always be sacrificed to profit, but both may be combined by judicious and experienced persons.

## GAPES

What the cholera is to adults the gapes are to chicks. Gapes are usually due to filth, the eating of the residuum of food previously given, and feeding in damp places. It is a thread-like worm, and must be destroyed. The best remedy for gapes, if the chicks will eat, is to add a teaspoonful of spirits of turpentine to a mixture of one pint of cornmeal and half a pint of middlings. Thoroughly incorporate the turpentine with the dry materials, then scald as much of the material as may be required, and feed to the chicks on a clean board. Put ten drops of carbolic acid in every pint of the drinking-water, and change the water frequently—once a day.

## IRREGULARITY IN FEEDING

When the suggestion is made to give green food to the hens it is not to be inferred that they are to be surfeited. Some do not allow green food for a week or more, and then will suddenly give the hens more than they desire. Such a mode of feeding will usually cause bowel disease, and should be avoided. The proper mode of feeding is to give the food in such a variety as to permit the hens to select that which they may prefer. Any system of feeding that causes the hens to be deprived at times and overfed at others, as well as sudden changes, will prove injurious.

## SELECTING FOR IMPROVEMENT

In every flock there will be one or two hens that will lay more eggs than the others, and these hens should be especially selected as the ones from which next year's pullets should come. But do not forget the fact that in the breeding of roosters there is an advantage to be gained by using the eggs from some pure-bred hen for that purpose. If some breeder would aim to so breed his hens as to select sires and dams descended from good laying stock only, the time will come when he will have added fully fifty per cent or more to the value of his flock.

## BANTAMS

The Bantams lay larger eggs than any of the full-sized breeds, in proportion to their size. It must be remembered that though a Bantam is small, yet it consumes but little food compared with large breeds, and four of them can be kept in place of an ordinary hen. They are not suitable for market, nor will their eggs sell rapidly, but for home use and where there is but little space they will be very profitable, for despite their diminutive size they lay the average number of eggs and are easily kept in confinement.

## MUSLIN-COVERED RUNS

Muslin does not usually last more than one season, but as it is a cheap material it can be economically used to cover the runs for little chicks. In fact, it can even be made to do good service in providing cover and shelter for the adults, where an outside run is desired. If one application of linseed-oil be given the muslin it will be very nearly water-proof. The advantage of muslin is that it is cheaper than glass, retains the heat longer, and the runs covered with it are always light.

## LICE

Do not wait for warm weather, and do not labor under the supposition that because lice do not get on you when you go into the poultry-house that they are not present. Pick up a hen and slowly and carefully look along the neck and top of the head, and the chances are you will find lice, and they will be very large and easily seen. The lice that travel over the poultry-house are the very small red mites, but those that you will find on the bodies of the hens do not leave the birds at all, but remain and multiply. If you see a single one, grease the legs, under the wings, necks and heads of all your hens, for if one has them none are exempt.

## CORRESPONDENCE

**A YEAR'S RECORD.**—Having been a reader of the FARM AND FIRESIDE for several years, and fairly interested in its topics in general, I at times am a little amused at the various opinions expressed, especially in the management of poultry. In the issue of January 15th a writer very sensibly says it is almost out of the question for any one to accurately advise the proper feed to give any flock of hens, as the flocks will differ in kinds, size and surroundings, which is much, very much, more than so many who prefer to know all will admit; but when the same writer says that if from twelve hens only six eggs are gotten daily it is plain that only six hens lay, I differ in opinion, for very many hens lay every other day, which can be affirmed by any observer who manages a flock of hens. Another says, as do others in general, that no one should raise any but pure breeds; that if the flock has been crossed with the different breeds the scrubs raised were neither fish, flesh nor fowl—certainly a hard specimen. It is safe to say that what one person fancies and quite worships another does not care for, whether pure breeds or scrubs. I have had pure stock which did well, and mixed lots which did equally well, but under different circumstances. The pure were non-sitters, and surely gave me the greater number of eggs; the scrubs were managed for profit, so far as could be obtained. Now, I am not a booster professionally, but I will give the yield of a flock, and they were scrubs. For the year 1899, on the first day of January I began with a flock of sixty hens—a mixture of Dorkings, Andalusians, Black Minorcas, Houdans, Spangled Hamburgs and Langshans, headed by three White Wyandotte cockerels. The total number of eggs given for the year was 6,529, market value \$98.27; I raised 100 chickens in an incubator, and the market value was \$30; total \$128.27. The cost of all feed, including oyster and clam shells, was \$39.65, leaving a profit of \$88.62. I have eight barrels of droppings not sold, but surely worth something. From the first occasionally one or two were taken for the table; several were sitting or caring for chickens, so that late in July only thirty hens were in the yard. This flock had free range, and a house and roost, which they took advantage of at any time; no patented feed was purchased, all feed was bought at the market prices, and so were all grains, but principally pop-corn, when wanted for use, as it is one of the best, and constitutes in itself a variety. I feed corn in the winter or cold months, none in summer. I do not presume this yield will not be beaten, but all features fairly considered it is a good average. I do not boast of hen-lice or dead hens, but have lost only three during the year. I will also say that this flock had all the refuse from the table. I started the present year with seventy hens, which are doing fair, but I do not predict as to the future. J. M. L.

Oak Summit, N. J.

## INQUIRIES ANSWERED

**American Seabrights.**—M. W. R., Midland City, Ill., writes: "Can you inform me where I can find the American Seabright chickens?"  
REPLY:—The breed is now known as Silver Wyandotte, the name having been changed about fifteen years ago. They are advertised in this paper.

**Swollen Heads.**—J. R. G., Brownsville, Tenn., writes: "My chickens are swollen about the eyes and head. Can you tell me the cause and remedy?"  
REPLY:—You should have given details of management. Probably the cause is drafts in the poultry-house. Keep them on straw for awhile—no roosts—and anoint with vaseline.

**Tonics.**—E. C. D., Cumberland, Md., writes: "Is gentian good as a tonic for laying hens? In what proportion must I feed it, and will it have any had effect on the egg organs?"  
REPLY:—It is regarded as a tonic, but is expensive and unnecessary. It has no effect on the generative organs. Fowls in a thrifty condition need no tonic.

**Breed for Timberland.**—A. M., Lemont, Ill., writes: "I am a farmer and have a good range for chickens. I have about twenty acres of timber. I would like you to tell me what you think is the best breed of chickens to raise. I have a good market for chickens and eggs."  
REPLY:—Probably the Leghorns would answer, as they are active and forage over a large area. Being flyers to a certain extent they would not be as easily destroyed by animal enemies as some breeds.

**Gluten-meal—Incubators.**—G. E. S., Montville, writes: "Is gluten-meal good for hens to increase eggs?—How much moisture is required in an incubator when the outside atmosphere is quite damp? Would it do any harm to put Plymouth Rock eggs and Leghorns in the incubator together?"  
REPLY:—Gluten-meal is regarded as an excellent addition to rations for poultry.—There is no rule for moisture; some incubators are not supplied with it at all, and good hatches are secured. Eggs from all breeds can be incubated at the same time.

**POTASH** gives color, flavor and firmness to all fruits. No good fruit can be raised without Potash.

Fertilizers containing at least 8 to 10% of Potash will give best results on all fruits. Write for our pamphlets, which ought to be in every farmer's library. They are sent free.

GERMAN KALI WORKS, 93 Nassau St., New York.

## KILLING LICE

by old methods of dusting and dipping poultry and stock is expensive and too slow. With our process, the hen or the hog sleeps at night on boards painted or sprinkled with  
**LEE'S LICE KILLER.**  
That's all there is to it. No handling of fowls or animals, yet perfect freedom from vermin. Special prices. Sample Free from Omaha with booklet.  
**GEO. H. LEE CO.,**  
Omaha, Neb., or 68 Murray St., N. Y.

## ROOM AT THE TOP

Recognizing that there was "room at the top," we have issued an ordinary catalogue but the  
**20th Century Poultry Book.**  
Contains the latest and best thought on the poultry question, from the egg through all its changes, to the market. No subject missed. Written from practical experience.  
The world renowned Reliable Incubators and Brooders, used all over the U. S. and in 41 foreign countries, receive deserved attention. Book mailed anywhere for 10c.  
**RELIABLE INC. & BROODER CO.,** Box B 41 Quincy, Ill.

IT COST US \$4,000 You Costs 15c

We have spent \$4,000 on our new book, "How to Make Money with Poultry and Incubators." It tells all. Leading poultry men have written special articles for it. 192 pages, 8x11 in. Illustrated. It's as good as  
**Gyphers Incubator**  
—and it's the best. Out hatch any other machine. 16 page circular free. Send 15 cts. in stamps for \$4,000 book No. 71.  
Address nearest office.  
**CYPHERS INCUBATOR CO.,**  
Chicago, Ill. Wayland, N. Y. Boston, Mass.

## The Globe Incubator

will hatch all fertile eggs. It is easy to operate! Any ordinary intelligent boy or girl can handle it. Our large 68 page catalogue sent free to any address. It tells all about the Improved Globe Incubators, Improved Globe Brooders, Triumph Hot Water Heaters for Poultry Houses. Wire Netting for Poultry Yards, best strains of pure bred fowls and poultry supplies. Write for it immediately, it only takes a postal card. Address,  
**C. C. SHOEMAKER, Box 753, Freeport, Ill., U. S. A.**

**HATCH** with the perfect, self-regulating, lowest priced first class hatcher—the  
**EXCELSIOR Incubator**  
Hatches the largest per cent. of fertile eggs at the lowest cost.  
**GEO. H. STAHL, Quincy, Ill.**

## The Star Incubator

is best because simplest in construction and in operation. Hatches every hatchable egg. Positive directions and no moisture. Perfect hatchers. 60-egg size, \$6. Illustrated catalogue free.  
**STAR INCUBATOR CO.,**  
34 Church Street, Bound Brook, N. J.

## PEERLESS

INCUBATORS are 365 days ahead of them all. It will pay you to send for catalogue. Address  
**THE PEERLESS CO., Box 50, Quincy, Ill.**  
Mfrs. also PEERLESS BONE CUTTERS & POULTRY SUPPLIES.

**The IMPROVED VICTOR Incubator**  
hatches all the fertile eggs; is simple, durable and easily operated. 168 page catalogue containing information and testimonials. Sent free. **GEO. ERTEL CO., QUINCY, ILL.**

**SUPERIOR INCUBATORS**  
Superior is yours if you buy a Superior machine. Each one guaranteed. Best regulated and ventilated machine made. Size from 66 eggs to 400. Price from \$5 to \$50. Send for FREE CATALOGUE, FULLY ILLUSTRATED. Contains many valuable recipes for farm and poultry. Superior Incubator Co., Xenia, Ohio.

**Great Hatches MONITOR INCUBATORS**  
are thoroughly successful, self-regulating, easily operated by unskilled person. Guaranteed satisfactory. Circulars free. Our big catalogue tells it all. Mailed for a stamp. The Monitor Co., Box D, Moodus, Conn.

**INCUBATOR FREE** on trial. Most perfect. Latest improvements. **The New C. Von Culin.** Catalogue FREE. Poultryman's plans 10c. Address:  
Ave. 77 THE W. T. FALCONER MFG. CO., JAMESTOWN, N. Y.

**DON'T SET HENS THE SAME OLD WAY**  
The Nat'l Hen Incubator beats old plan 3 to 1. Little in price, but big money-maker. Act-wanted. Send for cat. telling how to get one free. Natural Hen Incubator Co., B 22, Columbus, Neb. A. Edwards writes, "Would not take \$100 for N. H. I. Plan."

**\$5,000 POULTRY CATALOGUE FREE!**  
It is without a rival. Gives lowest prices of fowls and eggs. Over 50 breeds Turkeys, Geese, Ducks and Chickens. Hundreds of plates from life. 15 best poultry house plans. Treatise on diseases, how to feed, breed, etc. Send 10c. For postage.  
**J. R. Brabazon, Jr. & Co., Box 11, Delavan, Wis.**

**2000 PREMIUMS**  
were awarded my fowls at 12 State Shows in 1899.  
**FOWLS AND EGGS** sent  
Send 5c for illustrated catalogue. **FOR SALE**  
**CHAS. GAMMENDINGER, Box 68, Columbus, O.**

**GREIDER'S FINE CATALOGUE**  
of prize winning poultry for 1900. The finest poultry book out. A perfect guide to poultry raisers. Gives price of eggs & stock from the very best strains. It shows the finest chickens & describes them all. 50 different varieties. Everybody wants this book. Send 6c. in stamps B. H. GREIDER, Florin, Pa.

**DEATH TO LICE** on hens & chickens. 64-p. Book Free. D. J. Lambert, Box 303, Apopka, R. I.



## VETERINARY

CONDUCTED BY DR. H. J. DETMERS

To regular subscribers of the FARM AND FIRESIDE answers will be given through these columns free of charge. Where an immediate reply by mail is desired the applicant should enclose a fee of one dollar, otherwise no attention will be paid to such a request. Inquiries should always contain the writer's full address. Queries must be received at least TWO WEEKS before the date of the issue in which the answer is expected. Veterinary queries should be sent directly to Dr. H. J. DETMERS, 1315 Neil Avenue, Columbus, Ohio.

NOTE.—Parties who desire an answer to their inquiries in this column must give their name and address, not necessarily for publication, but for other good reasons. Anonymous inquiries are not answered.

**Infectious Abortion.**—J. W. M., Jaqua, Iowa. It is more rational and far safer to disinfect the external genitals of the cows before they are bred, and then to keep them on non-infected premises. See numerous answers headed "infectious abortion" in recent numbers of this paper.

**Barrenness.**—M. H. O., Harrishurg, Ark. The fact that your mare is always in season goes far to indicate that she suffers from nymphomania, a disease usually caused by a diseased condition of the ovaries. Barrenness may be due to various causes, and a diseased condition of the ovaries is one of them.

**A Hard Lump (?)—Color of Hereford Cattle.**—G. B. M., Wolf Island, Mo. I am unable to guess what it may be that you call "a hard lump," therefore I cannot answer your question. Hereford cattle as a rule are red with a white face or white head, white feet, and some white along the lower surface of the body.

**Fails to Give Milk from Fore Quarters.**—J. P., Donnellson, Ill. You probably neglected to milk the fore teats, and the calf found enough in the hind teats to satisfy all its wants. If it is not too late, as I suppose it will be when this reaches you, you may resort to vigorous and often-repeated milking. Nothing can be done by the use of medicines.

**Slavers.**—J. H. M., Hildreth, Neb. The slaving or slabbering of your horse is probably caused by moldy food, moldy hay, especially if the latter contains a large amount of clover, in particular. Make a thorough change in the diet of the animal, feed nothing but what is clean and free from fungi and fungous spores, and the slaving will soon stop.

**Bitter Milk.**—J. B., Spiceland, Ind. If the milk of your cow is getting bitter or strong a few hours after it has been standing it must be concluded that neither the cow nor her food are at fault, but that the milk becomes infected after it has been milked. What has to be done in such a case has been repeatedly explained in recent numbers of this paper.

**Probably a Case of Ringbone.**—J. H. W., Mountain Glen, Ill. What you describe appears to be a case of ringbone, possibly somewhat aggravated or slightly modified by the "rather short and straight pasterns." Concerning treatment please consult the FARM AND FIRESIDE of November 15, 1899. You must not expect that the lameness will be removed unless the animal has strict rest for about two months.

**Fistulous Sores.**—A. N., New Helena, Neb. What you describe appear to be fistulous sores, or rather fistulae, extending to the sternum, or breast-bone. A healing is possible if the treatment is conducted by a competent veterinarian who knows what he has to deal with, but if it is undertaken by anybody else the case must be considered a hopeless one. Neither condition powders nor any other internal medicine can do any good.

**Thirty-nine Blind Pigs.**—M. B. R., Kellog, Kan. Your statement that thirty-nine of your forty pigs were born blind is rather interesting, but since you killed the whole lot and give no other information than that the sire is a Jersey red and the dams Poland-China that is all I can say. A thorough investigation might have developed something of great interest. The fact that you threw some coal into the bog-plot a few times is in my opinion immaterial.

**Dysentery.**—B. D. M., Vilas, S. D. Dysentery (scours) of young calves less than three days old is practically incurable, and as it is most decidedly an infectious disease it can be prevented only by a most thorough cleaning and disinfection of the premises in or on which the calves are kept, and by a lasting improvement of the sanitary conditions. If calves over five days old become affected a cure is possible and usually effected by the following medicine: R. c. powdered opium, 10 grains; carb. of magnesia, 40 grains; best powdered rhubarb (rad. rhei), 30 grains; camomile tea, 5 ounces. This medicine is divided into two equal parts, one to be given in the morning and the other in the evening, or vice versa.

**Poll-evil.**—J. D., Kernville, Cal. What you describe is a so-called poll-evil, or in other words a complicated fistula at the poll. Although such a fistula can be brought to healing if the treatment is conducted by a competent surgeon thoroughly familiar with the anatomy of the parts affected and able to perform the necessary surgical operations, there is no prospect whatever that a poll-evil of six months' standing, and already subjected to various kinds of unsuccessful treatment, will ever be brought to healing by any treatment unless it is applied by somebody who is in every respect well qualified. It is therefore useless to give directions. The underlying principles are precisely the same as in the treatment of any other fistula, and have been repeatedly stated in these columns in answers headed "fistula." Only in cases of poll-evil the surgical operations for obvious reasons have to be performed with greater care and circumspection.

**Periodical Lameness.**—J. C. S., East Woodstock, Conn. Such a peculiar intermittent lameness as you describe is observed if one or more of the larger branches (most frequently the crural arteries) of the posterior aorta have become more or less completely closed by thrombosis, and if in that way certain groups of muscles are deprived of a sufficient supply of blood. In such cases exemption from work, some voluntary exercise and time may effect improvement, but any medicinal treatment is out of the question.

**Influenza.**—H. K., Germantown, Ohio. The disease you describe appears to be what was formerly known as the gastric form of influenza, and even now, since the infectious pneumopleuritis of horses is by common consent not any more considered as a form of influenza, that name may be maintained, at least will be understood by every veterinarian. Being an infectious disease it very often assumes epizootic proportions, and where it has once gained a foothold it is sure to unexpectedly make its appearance here and there after it had apparently disappeared.

**A Horny Scar.**—R. C. N., Yale, Ohio. Whenever a horse is severely wounded on either a fore or hind leg anywhere below the so-called chestnut or horny wart, and the wound is not brought to healing by first intention, but is kept open and allowed to suppurate, such a growth or horny scar as you say is existing just above the hoof of your horse, where the same was severely wounded last July, will be the inevitable result. Such a scar will be the larger and the uglier the more extensive or severe the wound, and the longer it took to bring it to healing. The best that can be done in such a case is to leave the scar alone, to keep it clean and not to "monkey" with it.

**Wild Calves (?)**—C. M. F., Confidence, W. Va. Parties sending inquiries to be answered in the veterinary column of the FARM AND FIRESIDE should give a description of the case in question and not make use of local terms, possibly well enough understood in the locality in which the party making the inquiry resides, but perhaps nowhere else. The territory over which the circulation of the FARM AND FIRESIDE extends is a great deal too large to enable any one person to be familiar with all the local terms applied occasionally to signify diseases or ailments of live stock. So it is with the term "wild calves" used by you, for I have no idea what you may mean by it, except that I feel confident that you do not mean a calf that is wild—in opposition to tame or docile.

**Choking of Hogs.**—T. S., College Springs, Iowa. Since you give no further particulars, it must be supposed that the cause of the choking must be looked for in the food, and perhaps its preparation, and not in the hogs. As is well known, every good hog is a glutton, and that must be taken into consideration in preparing the food, which if wholly or partly composed of meal, bran or other similar substances, must not be too thick and be free from lumps, and if root-crops are fed the same must either be in such large pieces that the hog is compelled to masticate them or the single pieces must be so small that they can be easily swallowed without any mastication. There is also danger if slop is fed. I know of more than one case in which a dish-rag got into the slop, and caused the death of a hog by choking.

**Probably So-called Ringworm.**—H. C. S., Livermore, Maine, and E. S. S., Canal Dover, Ohio. What you describe appears to be a case of so-called ringworm. It is very contagious, but it will yield to treatment. Paint the round blotches as soon as they make their appearance once a day with tincture of iodine, but when doing so see to it that none of the tincture gets into the eyes. Keep the yet healthy and the diseased animals strictly separate, the healthy ones, of course, in a non-infected place. Subject the premises where the diseased animals are kept once a day to a thorough cleaning, and thoroughly disinfect them as soon as the last case of the disease has yielded to treatment, for if this is not done the disease will surely make its reappearance. Also disinfect all grooming-utensils.

**Weakness in the Hind Quarters—Worms.**—C. S., Sunman, Ind. Since you found that the pig or shoat which you killed because it was the weakest and unable to get up had its small intestines full of worms from four inches (the males) to one foot (the females) long, it appears highly probable that these very worms, known as Echinorhynchus gigas, constitute indirectly, at least, the cause of the whole trouble. First by interfering with the process of digestion, and thus with the process of nutrition, and secondly by directly decreasing the existing amount of blood and interfering with the circulation of the same. The eggs of these worms, passing off with the dung, are deposited wherever the affected pigs drop their excrements, and these eggs, it is claimed, develop to embryos in the larvae of the May-hug, Melolontha vulgaris, which in the spring are greedily consumed by the young pigs. The prevention, therefore, consists in removing the excrements as often as possible from the premises where the pigs are kept to a place where no damage can be done, or in which they can be burned, and then in the spring, as soon as your pigs are born, to keep the place where they are kept scrupulously clean, so that the larvae of the May-hug cannot exist. Where the worms have already invaded the small intestines it is difficult to expel them, for the simple reason that they do not feed upon the contents of the intestines, but by burrowing their heads into the intestinal mucous membrane, upon the exudates thus procured and the blood thus drawn. It has been recommended to feed to pigs infested with these worms mucilaginous decoctions—for instance, decoctions of flaxseed, and with them decocted castor-beans, two drams for each dose.

**Grubs in the Heads of Sheep.**—J. Y. B., Charlestown, Ind. The grubs in the heads of sheep are the larvae of a fly known as Oestrus ovis. One may possibly succeed in expelling some of the larvae from the nasal cavities and the frontal sinuses by putting snuff into the nostrils of the sheep, and thus causing them to sneeze, but only few of those in the frontal sinuses and none of those in the maxillary sinuses will be removed. Therefore, the snuff treatment can be expected to do some good only if applied early in the season, when the larvae are yet small, and when most of them have not advanced beyond the nasal cavities. As a means of preventing the sheep, but particularly the lambs, should be kept away from timber pastures and pastures surrounded by hedges during the time the flies are swarming. Where this is impossible experienced shepherds smear tar on the borders of the nostrils of the sheep to prevent the flies depositing their eggs, or rather to prevent the embryos, which soon hatch, crawling over the border of the nostril into the nasal cavities.

**Attacks of Disordered Digestion.**—S. W. A., Annelly, Kan. The few symptoms you give appear to be the product of a disordered digestion, but a disordered digestion may be the result of quite a number of widely differing causes. It is true that indigestible food, especially if consumed in large quantities—food that possesses noxious qualities and food having a great tendency to ferment—may in some cases constitute the sole cause. It is also true that the second-growth cane consumed by your cow just before the first attack made its appearance may have acted as an auxiliary cause, but it is not at all probable that it constituted the sole, or even the principal cause, because later other attacks occurred after your cow, according to your statements, had perfectly recovered, and that at times when there was no food with an extraordinary tendency to ferment within reach, and when the food consists of good prairie hay, corn fodder, oats and corn, unless it be that the corn fodder was spoiled and consumed in considerable quantities, something which you did not say to be the case. Eliminate the corn fodder, and feed nothing but what is absolutely sound and digestible, and if then other attacks make their appearance have the cow examined by a competent veterinarian, or subject her to a tuberculin test.

**Pneumonia and Distemper—A Lame Mule.**—C. B. S., Camden, S. C. You, like many others, evidently labor under the mistaken idea that all diseases commonly known under the same name are precisely alike, and that for every one of them a specific remedy is existing, so that all that is needed in the treatment of diseased animals is to know the name of the disease and the name of the specific remedy, and then to go to a drug-store to get it and give it to the diseased animal. Nothing is more erroneous and further from the truth. If you cannot get a good veterinarian to examine and to treat your sick animals, the best you can do is to dispense with all and any medication, to keep your diseased horses on a rational diet, to feed moderate quantities of good sound food easy of digestion, give them pure water to drink, procure good ventilation without exposing the animals to any direct draft, and keep the premises as clean as possible and free from foul air and any accumulations of manure. Besides this, sick horses, but especially if suffering from pneumonia, must have perfect rest. If in cases of distemper abscesses are forming they should be opened at the lowest point as soon as they are ripe, and in such a way that the pus can be discharged from every part or point.—Concerning your lame mule I cannot make any diagnosis upon what you have been advised to do, or upon what you think might be, but will suggest the possibility of laminitis, or so-called founder.

**Weak in the Hind Quarters.**—F. D., St. Charles, Minn. If the disease of your mare, now weak in the hind quarters, had been hemoglobinemia, or so-called azoturia, and the attack such a mild one that she was never unable to get up, she would have fully recovered before this, even without any treatment whatever except rest and good care. Besides this, you do not mention the most characteristic symptom of that disease, namely, the dark or blood-colored urine, dark or blood-colored on account of the dissolved hemoglobin it contains in hemoglobinemia. For this reason, and because you state that the mare when you bought her last September "walked wider behind than in front," I must come to the conclusion that the paralytic affection in the hind quarters is not caused by the disease you accuse, but by morbid changes in the posterior part of the spinal cord; that is, where the large nerves governing the movements of the hind legs are branching off. The kidneys have absolutely nothing to do with it. Cases like this as a rule are incurable. Still in some instances, particularly if the weakness or partial paralysis is yet of recent origin, improvement will be observed if the affected animal is kept in a loose box, or has some voluntary exercise. Therefore, a partial recovery or some improvement may be effected if such an animal is sent to pasture, provided there are no other animals which will chase or trouble it. If your other mare, of which you say that she always has been fat, "acts dumpy" only just before a storm or when "chilled," it must be presumed that the cause very likely consists in want of blood in, or an enemic condition of the brain, and not, as is usually the case in an abnormal pressure upon the brain, produced by exudates or by other causes, for then the dumpyishness would manifest itself in warm weather or when the animal is excited or warmed up by exercise. With this mare you may try more work and more blood-giving and less fat-producing food, and feeding oats instead of corn.

## EMPIRE

## CREAM SEPARATORS.

Do you know them? They are superior to all others in points that mean money. Being *lightest running*, they save work. They miss less than one-tenth of one per cent. of the butter fat. They increase quantity of butter. These are part of their advantages.



Write to-day for illustrated free catalogue. You need it if you own three cows. It tells how to increase your butter output by 25%.

U. S. BUTTER EXTRACTOR CO.,  
227 High Street, Newark, N. J.

## ONE MILLION PACKAGES FLOWER SEEDS FREE.

This Mammoth Collection contains the cream of all flower seeds—just what you want to make a Magnificent Garden. Exquisite varieties of elegant, brilliant, dazzling flowers, as follows:

Dovey Victory . . . 10 col.	Zinnias . . . 12 col.
Hobson's Choice . . . 3 "	Sweet Williams . . . 12 "
Crown Bellefleur . . . 2 "	Ageratum . . . 3 "
Ten Weeks' Stock . . . 12 "	Morning Glory . . . 15 "
Swet Alyssum . . . 2 "	Forget-me-not . . . 2 "
Four-O'clock . . . 3 "	Nasturtium . . . 12 "
Poppy . . . 18 "	Asters . . . 16 "
Larkspur . . . 6 "	Pinks . . . 10 "
Portulaca . . . 20 "	Sweet Peas . . . 10 "
Marigold . . . 13 "	Calliopis . . . 8 "
Pansy . . . 10 "	Calendula . . . 5 "
Verbena . . . 8 "	

A WHOLE FLOWER GARDEN FREE.  
To introduce our Beautiful Ladies Magazine in new homes we will on receipt 10 cents in stamps or silver send it 3 months, also all the above Flower Seeds 23 different kinds, Order Quick.  
SOCIAL MAGAZINE, BOX 3139, BOSTON MASS.

**HAS NO EQUAL**  
For  
Spavins,  
Ringbone  
Splints,  
Curbs,  
and all forms of  
Lameness,  
bunches or bony  
enlargements.

Uvalde, Texas, Nov. 12, 1898.  
Gentlemen—Enclosed find a two-cent stamp for which please send me your "Treatise on the Horse and his Diseases." Your Spavin Cure is simply wonderful. Resp'y, P. S. GREAVES.  
As a liniment for family use it has no equal. Price \$1; six for \$5. Ask your druggist for Kendall's Spavin Cure; also "A Treatise on the Horse," the book free, or address DR. B. J. KENDALL CO., ENOSBURG FALLS, VT.

## Send 25 cts.

in stamps or coin, and state whether you want  
Seven Superb Sweet-Peas  
Seven Showy Nasturtiums  
Seven Artistic Asters

or ten packets Assorted Annual Flowers, and you will receive by first mail an unequalled collection.

Or simply send your address on a postal-card to W. Atlee Burpee & Co., Seed Growers, Philadelphia, and you will receive

BURPEE'S FARM ANNUAL FOR 1900  
This is "the only salesman" of the largest mail seed trade in the world, and tells all about the

BEST SEEDS THAT GROW

**Wide Tires Make Good Roads.**  
**GOSHEN**  
LOW WAGON  
**WHEELS**  
have wide tires—3½ to 6 in. Just see how it's made—layer upon layer of kiln dried Indiana White Oak, cut wedge shaped, grain running from hub to tire. Look how it's riveted. Look at the broad flanges with bolts running

KELLY F'DRY & MACH. CO. Clear through. MAKERS OF THE FAMOUS "GOSHEN" STEEL TANKS. 12 Purl St., Coshen, Ind. Circulars &c. Free.

**BICYCLES FOR EVERYBODY.**  
NO MONEY IN ADVANCE.  
Shipped direct to anyone and guaranteed as represented or money refunded. Save agents large profits and get a wheel at rock bottom wholesale price. Our Arlington Model K is the greatest bargain ever offered; in lots of one or more at \$14.85  
\$35 "Arlington" \$16.50  
\$40 " " \$18.50  
\$50 "Oakwood" \$21.50  
Good wheels \$12.50, \$11.00 & \$10.00. Stripped wheels \$7.00 and the best that can be made. Thoroughly tested and fully guaranteed. Over 100,000 riders can testify to their superior quality, style, construction and workmanship. Illustrated catalog free. CASH BUYERS' UNION, 162 W. Van Buren St., B-7, Chicago, Ills.

**"CORED TO DEATH"**  
is the startling headline of many a news paper article. Hornless animals are safe. Done with the  
**DEHORNING KEYSTONE KNIFE**  
causes less pain than any device made. Cuts on 4 sides at once—clean and quick, no crushing or tearing. Fully warranted. Circulars &c. FREE.  
A. C. BROSIUS, COCHRANVILLE, PENN.

Highest Award at the World's Fair.



THE GRANGE

Conducted by MRS. MARY E. LEE, New Plymouth, Ohio

WANTED—A BOY

This is a standing advertisement in every paper we read. "A Boy Wanted." Is it that boys are so scarce that high-priced advertisements are appearing all over the country? Not at all. The country is full of young people, especially boys. They are everywhere to be seen. There are a hundred on the street-corners of Logan. It would seem that a business man need not pay five dollars for an advertisement in a paper to get a boy for his service when the country is so full of them.

But the "boy wanted" is a scarce article. The street boy is the nuisance nobody wants. The boy wanted is the lad who listens to the advice of his parents. He is a boy willing to work and do what he is told to do by the man who employs him. He is honest of heart, truthful, polite, obedient. He tries to earn more than the salary promised. That boy when he comes to years is a man among men who "run" the country. The herd of lads who flock the street-corners, whose tongues are vile with blasphemy and obscenity, who think it smart to play the "old man," be it father or employer, are not wanted by anybody, unless it shortly will be the policeman, the manager of the work-house, a home at last in pen or poorhouse.

There is a greater demand for "boys" in this country to-day than for anything this country of ours produces. Strong-limbed, clear-headed, pure-hearted young men are wanted in every line of business. Honorable place, profitable employment, success.

For the rough and tough, the ignorant and indolent, the iron hooks of the law are reaching out to grab them for service on the stone-pile or a sleeping-place in the jail.

"Boy wanted!" What boy? We have before us applications from business men for four boys. The conditions are honesty, decency, industry, politeness. No boy can get service in any of the desirable places of service unless he conforms to the regulations which are based upon our civilization.

The railroad requires that its employees shall be gentlemen, that they are polite, that they do not swear, that they pay their debts, that they keep out of saloons, that they do not keep bad company, that they save their money. The banks, the business houses, all the trades and professions employing boys or men make the same conditions. The boy or man only gets his job because he comes recommended on these qualifications, and only holds his job while he proves faithful. Boys and men are wanted. Wanted everywhere, the good boy, the good man.—Lewis Green, in Hocking Sentinel.

We print the above because it voices the sentiment of successful business men. Mr. Green is a veteran editor, a man of wide experience, a keen observer of men and events. What he says is true.

For some reason there is a wide-spread despair, a feeling that there are no opportunities for the young man of to-day. Possibly it is owing to the cry of the demagogue about the poor laboring man and the greedy oppression of "soulless corporations," or to the feeling of mingled awe and wonder with which one views the rapid and varied changes in the field of productive activity. Certain it is that every decade witnesses the same despair and discontent, the same successes and failures. The march of progress goes steadily on, ever opening up new and rarer fields of industry, developing new wants and necessities, calling for men and women of wider capacities. To-day there are more opportunities than ever before. To-morrow will open up yet others. Every wish gratified gives birth to a new desire. It needs only the seeing eye to perceive, the determined will to do, to render the life of each person a blessing to himself and humanity.

Schools and colleges have been established and endowed to fit men for the demands of the times. In return is demanded more intelligent and conscientious service. The man unwilling to render that service must step down and out and give to others the place he cannot fill. Life is a constant selection and rejection, the capable going on and up, the incapable falling under the stern law of fate. Manifestly the boy with the best training, the widest knowledge, the greatest integrity and trustworthiness will naturally be called to fill the higher positions in life. Such combinations are too rare to be rejected by a selfish world.

Men of limited capacities, but with rare

qualifications of brass and gall and a "pull," secure and hold positions for a time. But new conditions arise, their "pull" is of no avail, and their brazen effrontery rises like Banquo's ghost to accuse them. Thus Nemesis, that stern task-mistress of mankind, rewards or punishes according to human worth.

My country boy, weary with the petty details of farm-life, cramped and shut in by a fate that seems too hard, whose horizon is bounded by a neighboring hill, whose outlook is narrow and sordid, take courage. You have within you capacities to be developed. Faithfully perform your duties, and thereby create habits of industry and integrity. Increase your store of knowledge. Let every moment add a new grace to your mind. Be industrious, economical. Then let your chosen work be what it may, whether on farm, in shop, in professional life or in office, success will attend your efforts.

PARTISAN POLITICS IN THE GRANGE

At the late meeting of the Ohio State Grange a good brother intimated that taking action on the "initiative and referendum" was disregarding the rules of the order and taking politics into the grange. There seems to be a feeling that members must not touch upon anything that is a party issue, yet one of the principal purposes of the grange is to educate and help the rural classes. Many a man and woman works hard and constantly on the farm to make a living, with but little time for reading, and seldom attending a lecture or meeting where they can be informed on these matters. The grange is about their only opportunity, and did it debar them of this one chance it would not be true to its fundamental principles. There must be a mistake somewhere. I am very sure that I have seen or heard the statement that we could study or discuss any issue like the "protective tariff," the "gold standard," the "initiative referendum," and even take a vote thereon, but must not work for any political party while at the grange, nor work for any candidate. If any one, when at a regular grange meeting, had made a speech for State Master Ellis as a candidate for governor, and had tried to persuade the members to vote for him, that would have been taking party politics into the grange. Is that not the correct idea of this matter? MARY CURTISS.

In questions of this nature we must go to the constitution for an answer. Article xii. reads: "Sectarian or partisan questions will not be tolerated as subjects of discussion in the work of the order." In our declaration of purposes we find the following: "No grange, if it is true to its obligation, can discuss partisan or sectarian questions, nor call political conventions, nor nominate candidates, nor even discuss their merits in its meetings. Yet the principles we teach underlie all true politics, all true statesmanship, and if properly carried out will tend to purify the whole political atmosphere of our country. For we seek the greatest good of all."

It is true, as our correspondent says, that some farmers have little other opportunity than the grange meetings for their enlightenment. Yet such is human nature that partisan questions cannot be discussed without bitterness arising from the discussion. After all, there are matters of greater import than the political questions. These are but outward manifestations of underlying principles. The principles are eternal, and every grange in the land can discuss them to their heart's content, and did they follow them the world would be a brighter place to live in. Even partisan questions could then be discussed without bitterness and acrimony. All moral, social and religious discussions are founded on the questions of man's relation to his fellow-man. When we fully comprehend the meaning of the divine command, "Thou shalt love thy neighbor as thyself," then can we find answer to the questions we ask. For "Love worketh no ill to his neighbor; therefore love is the fulfilling of the law."

All questions at issue between the parties do not arise from a natural sequence of events. Many are decided upon in party conclaves as likely to tickle the popular fancy and to win success for the party promulgating them. Too often partisan success is placed before the question of the greatest good to the greatest number. But so strong is partisan feeling, so inherent in us it is to believe what it is to our interest to believe, that people champion questions wholly at variance with their ideas of right. My party says so, the hated opposition cannot be right, therefore my party is right, is

their method of reasoning. If their conscience is likely to get the upper hand of them, and cause them to withhold their support, his santanic majesty suggests to them the past history of their party and the wicked devices of the opposition. Under such conditions is it safe for members of an order to discuss partisan questions?

Let us penetrate further than political issues. Let us get at the substance rather than the semblance of our national ills.

Be true to your own judgment. Let not imagination and delusive dreams woo you from that "sternness of veracity," as Carlyle phrases it, which knows no law but that of reason and sense.

\*\*\*

If your grange has a member that has studied botany, or is sufficiently interested to study it this year, ask him to give a short talk at each meeting. Many who feel that they have not time nor inclination to study text-books on the subject would be led to observe the phenomena of Nature. Our lecturer, knowing that her grange would not make a systematic study of the subject, stole a march on the members. The word "botany" was not mentioned. During an informal discussion of a plant disease that was attacking their shade-trees she asked how many could tell from memory the shape of the leaf of the hard maple. A few could. Several did not know just what maple was referred to. This led to the suggestion that leaves of all the different kinds of maples in the neighborhood be collected. Several complied with the request. Then the question arose as to the attachment of the leaves to the twigs, their position, etc. She asked them to notice whether the limbs on an oak were thrown out in the same way as in maples. Gradually one question followed another until each member was interested in observing the trees as he passed them on his way home. Before the season was over that grange knew more of botany than many students who have given a term of college to the study of it. Nor did they think of the matter as a systematic study of botany. It was simply a matter of interest to observe the plant-life about them. This is the most successful way of getting people to study any question. First create an interest. Their curiosity will cause them to pursue the investigation of the subject. It is almost useless to tell one he ought to inform himself on such and such a subject. It is about the surest way of defeating your own aims that you could find.

\*\*\*

"Men at some time are masters of their fates."—Shakespeare.

GRANGE POINTERS

The installation ceremonies should not all end in words. Serious, solemn duties have been assumed. Let the trust be appreciated.

Let all officers remember the words of the obligation at installation, and "keep each obligation a gem of thy soul."

The grange press continues to be one of our most powerful allies. In fact, there never has been a time in our history where the press generally has been so friendly to our organization as at present. Let us show our appreciation by subscription and correspondence.

True education is what broadens our lives, widens our sympathies and uplifts our ideas to truer and better conceptions of the duties and obligations of life.—Mrs. F. D. Saunders, Lecturer of Michigan State Grange.

BUSINESSLIKE ORGANIZATION

It is well known to all that during the past thirty years farmers have had presented to them for adoption and use several different organizations. All these claimed advantages to farmers along the same general lines. Most of these organizations have come and gone. Practically but one remains. A diagnosis to learn the cause of the failure of the many, and the survival of the now only farmers' organization of a local, state and national character, proves that a farmers' organization to be successful must be planned on business principles. The organization to answer the demands of the day must be not only local, but as broad as the wants of agriculture in the nation. It must not be so simplified and cheapened that the essentials to success are sacrificed.

The Order of Patrons of Husbandry, known as the Grange, is shown by this series of experimenting to have been organized on a sound and business basis. This is proved by its survival and its now grand existence as the most helpful agent the farmers of our country can employ.—G. B. Horton, in Michigan Farmer.



Special Trial Offer New and GRAND PANSIES

Did you ever see 7 straight or circular rows of pansies, side by side, each a different color? If so, you know that the effect is charming beyond conception. Did you ever see Childs' Giant Pansies, marvels in beauty and true to color? If not, you have not seen the beauty and perfection now attained.

- As a trial offer, we will mail for 25 cents:
  - 50 seeds Pansy Giant, Pure Snow White,
  - 50 " " " Coal Black,
  - 50 " " " Cardinal Red,
  - 50 " " " Bright Yellow,
  - 50 " " " Azure Blue,
  - 50 " " " Bright Violet,
  - 50 " " " Striped, Variegated.

A little book on Pansies, telling all about culture, etc. A Booklet of 95 pages on House Plants; tells just how to care for every kind of window plant. THE MAYFLOWER magazine 3 months; finest publication on Flowers and Gardening. And our Catalogue of 156 pages and 9 Colored Plates.

The 7 Pansies, 2 Books, Mayflower and Cat's, 25c. Our Catalogue for 1900—25th Anniversary Edition—greatest Book of Flower and Vegetable Seeds, Bulbs, Plants and New Fruits, 156 pages, 500 illustrations, 9 colored plates, will be mailed free to any who anticipate purchasing. Great Novelties in Sweet Scented and Tuberosus Rex Begonias, Geraniums, Fragrant Calla, Treasure Vine, Gooseflower, Caladiums, Everblooming Tritoma, Cannas, Gladiolus, Roses, Phloxes, Giant Pansy, Lilies, Palms, Carnations, Primroses, Asters, Pansies, Sweet Peas, Verbenas, Tomatoes, Strawberries, etc.

John Lewis Childs, Floral Park, N. Y.

Burpee SEEDS

are the most popular

They are sent out only in sealed packages from the New Burpee Building, Philadelphia. A postal-card application will bring

Burpee's Farm Annual for 1900

which tells all about the Best Seeds that Grow, as tested at Fordhook Farms—the largest trial grounds in America.

No matter how many other seed catalogues you may have, you cannot be thoroughly posted without Burpee's. WRITE TO-DAY. Address simply

BURPEE, Philadelphia

\$2,500.00

In cash prizes is one of the many interesting features of our new catalogue for 1900. Planters of Maule's Seeds are successful people. Maule's Seeds lead all; have done so for years and are as far ahead as ever in the race. Our new catalogue for 1900 is

FREE to ALL

who apply for it. It contains everything good, old or new, with hundreds of illustrations, four colored plates and practical up-to-date cultural directions. It is pronounced the brightest and best seed book of the year. Write for it to-day. Address

WM. HENRY MAULE, Philadelphia.



EVERGREENS.

Largest stock in America, including Colorado Blue Spruce and Douglas Spruce of Colorado.

Also Ornamental, Shade and Forest Trees, Tree Seeds, Etc. E. DOUGLAS & SONS, Waukegan, Ill.

THE MILLION DOLLAR POTATO

Most talked of potato on earth! Our Catalog tells—so also about Salzer's Earliest Six Weeks' Potato. Largest farm and vegetable seed growers in U.S. Potatoes, \$1.20 and up a bbl. Send this notice and 5c. stamp for Big Catalog, F-156

JOHN A. SALZER SEED & LA CROSSE WIS.

15 FULL-SIZE PACKETS FINEST FLOWER SEEDS 10c.

For 10 cents we will send one full-size packet of each of the following fresh, vigorous, tested Flower Seeds: Chrysanthemum Aster, all colors; Victoria Aster, all colors; Camellia-Flowered Baisam, all colors; Giant Cosmos, all colors; Marigold, 10 kinds; Morning-Glory, mixed; Pansies, 25 kinds; Petunias, mixed colors; Phlox Drummondii, all colors; Poppies, 10 kinds; Verbena, all colors; Giant Zinnias, all colors; Giant Empress Candy-tuft, Sweet Alyssum, Mignonette. Catalogue of Flower and Vegetable Seeds free. The Paul Company, Red Bank, N. J.



Finest in the Spray. Most thorough in stirring. Easiest in the Work are the excellent characteristics of the

Empire King,

the only pump having automatic agitator with brush for cleaning strainer. No leather or rubber valves to rot. We have sprayers of all sizes and styles. Our

Field Force Pump Co., 26 Market St., Lockport, N.Y.

SPRAY Your Fruit Trees and Vines

24 styles spraying outfits. Best and cheapest. For prices and full treatise on spraying all Fruit and Vegetable crops address WILLIAM STAHL, Quincy, Illinois.

450,000 TREES

200 varieties. Also Grapes, Small Fruits, etc. Best rooted stock. Genuine, cheap. 2 sample currants mailed for 10c. Desc. price-list free. LEWIS ROESCH, Fredonia, N. Y.



## CARRYING EASTER JOY



ITH flowers, music and praise we greet the holy day of Easter. In our joyous determination to add all the brightness possible to the day we generously give remembrances to our friends.

The Easter booklets are often original, artistic and very religious. Several choir-boys in their white vestments joyously singing are the decorations on one, while within, in letters of gold, is this verse from Charles Wesley's glorious hymn:

"Christ the Lord is risen to-day,  
Sons of men and angels say;  
Raise your joys and triumphs high,  
Sing, ye heavens, and earth reply."

Clever fingers have made an artistic little painting of "the Madonna and the child" on this cover; on two of the leaves graceful, nodding lilies are growing; the third gives a glimpse of a violet-bed. This is the Easter faith the booklet carries: "On this glad Easter we know that Christ has risen and that in the King's garden we shall find our own again."

Another is a suggestion from the studio, in gold letters, on a very light pink background, "Jesus is King," and "Easter, 1900;" within will be painted two angels, and the scroll they bear unrolled across several pages will be inscribed with this quotation from "The Koran:" "Two angels guard every man on earth, one watching on each side of him, and when at night he sleeps they fly up to heaven with a written report of all his words and actions during the day." Every good thing he does is recorded at once and repeated ten times, lest some item may be omitted or lost from the account. But when they come to a sinful thing, the angel on the right side says to the one on the left, "Forbear to record that for seven hours, or peradventure, as he wakes and thinks in the quiet hours, he may be sorry for it and repent, and pray, and obtain forgiveness."

Very original would be a flock of birds soaring between earth and heaven, with Easter lilies and daffodils smilingly nodding to each other from opposite pages, and accompanying them:

"The world itself keeps Easter day,  
And Easter birds are singing;  
And Easter flowers are blooming gay,  
And Easter buds are springing.  
The Lord is risen, as all things tell,  
Good Christians, see ye rise as well!"

On a cream-tinted background white and light blue pansies would be very suggestive of pure and heavenly thoughts, and could illustrate Lucy Larcom's "Easter:"

"Little children dear, look up!  
Toward His brightness pressing,  
Lift up every heart, a cup  
For the dear Lord's blessing."

Lilies are used effectively on a daintily shaded green booklet, and this precious verse from Whittier's "Easter Lilies" was chosen:

"A thought of Love Immortal blends  
With dear remembrances of friends,  
And in these earth-born flowers,  
With Eden's lingering fragrance sweet,  
The heavenly and the human meet,  
The heart of Christ and ours!"

ADELE K. JOHNSON.

### EASTER FOR THE CHILDREN

The youngsters who are fond of "good times" are inclined to resent the fact that "Easter comes on Sunday every year," as a certain small boy dolefully expresses it. But the children can be made very happy with a little Easter party on Saturday evening, and impressive lessons of the Easter season can be made a part of the "Easter eve entertainment."

It is a mistake to imagine that children can be pleased only with costly gifts. Child-nature is the same among the rich and the poor, and unless trained by exceedingly foolish parents simple gifts are appreciated just as much as if much money had been spent upon them. In the matter of Easter gifts a wholesome child will enjoy the eggs which have been prepared at home quite as much as if two or three dollars had been expended upon them. The German custom of dyeing a large number of eggs and hiding them in all the nooks and corners of the

house and garden is fast becoming popular, and there is no way of entertaining children at Easter that is more enjoyed by the little folks than this.

Decide upon the number of children that you wish to entertain, then dye enough eggs for each child to receive several.

If you wish to use cochineal, purchase five cents' worth, put it in an old saucepan, and slowly add boiling water until the liquid is a deep red shade. Boil for five minutes, then draw back from the fire, add the eggs, again bring to a boil, and after fifteen minutes remove.

Dark or light shades of red or pink may be made by the addition of water. Logwood may be used in the same way, or some of the prepared dyes may be used. Hide the eggs in easy hiding-places around the garden or house, and let them be placed in a large, gaily decorated nest when found until all have been discovered. The names of the children may be scratched on the eggs, or the decalcomania names may be used for the decorations. After all the eggs have been found divide them among the children. Pretty little baskets of sweet-grass may be provided as souvenirs of the occasion, in which the eggs may be carried home by the children. It is not necessary to provide refreshments, but if necessary a simple little luncheon may be served as follows:

Chocolate.  
Cold Chicken.  
Sliced Tongue.  
Butter and Sugar Sandwiches.  
Strawberry and Vanilla Ice-cream.  
Lady-fingers.

For the table decorations a large hen on her nest, surrounded by a brood of little chickens, will be enjoyed by the little ones. It is best to arrange early hours for this entertainment, such as from three to five, so that the children may return early to their homes.

**MAKING THE EASTER CANDIES.**—Although a number of candy rabbits and large and small chocolate-covered Easter eggs must have a prominent place among the Easter sweetmeats, the most of the candies may be made at home, and if desired the cream candies may be manufactured by the children as a part of the evening's entertainment, although the sugar and molasses candies that require boiling should be prepared before the arrival of the children, so that there will be no danger of soiling the "best bib and tucker" of the little guests.

**CREAM MINTS.**—Melt two cupfuls of granulated sugar with one half cupful of cold water, and stir until the sugar is dissolved. Boil exactly three minutes—no longer. Remove from the fire and add three drops of oil of peppermint, then stir quickly with a spoon until creamy, and drop on sheets of buttered paper in small humps. The following day they may be dipped into melted chocolate if desired. This adds greatly to their attractiveness.

**SUGAR CANDY.**—One of the best candies that can be given to children may be made as follows: Pour one cupful of vinegar over six cupfuls of sugar. Add a teaspoonful of saleratus to a cupful of water, and add it to the other ingredients. Next add a tablespoonful of butter to the mixture, and boil for half an hour without stirring. Grease the fingers and pull until white.

**CREAM DATES.**—Take the white of an egg and an equal quantity of cold water. Stir until well mixed but not until light, then add enough confectioner's sugar to thicken—about a pound or a pound and a quarter will be required. Remove the stones from dates, roll a lump of the cream into a long roll and fill it into the space left by the removal of the stone. This cream may be used in many ways. Nut candies may be made as follows: Take a lump of the cream as large as a hickory-nut, and place on either side of it a kernel from an English walnut. Squeeze the two kernels well together and a rim of the cream will come out all around the nuts. These are very delicious. This same foundation material may be used to form the Easter-egg confections, as it is easily rolled into the large or small eggs, which may be flavored as desired, chocolate-covered, mixed with finely grated cocoanut, or formed with centers of nuts, raisins or chopped dates.

**THE EASTER BONBONNIERES.**—The children will be perfectly satisfied with their Easter candies without special arrangement

for dainty serving, but when they are intended for gatherings of older people, or are to be presented as Easter gifts, attractive bonbonnières will add greatly to their value. We are assured that this season's sweets come in finer shapes than usual. The boxes are "pretty enough to eat," and there are wicker baskets filled with comfits, china eggs packed with candy, and all sorts of ornithological oddities.

Happy is the maid who, after having abstained for forty days from candies and sweets of all kinds, finds a box of her favorite bonbons on Easter Sunday morning at her place at the family breakfast-table! Doubly acceptable, of course, is the gift if it in some way suggests the time-honored emblem of Eastertide, and the choice of such bonbonnières is just now an embarrassment of riches.

A basket of pale yellow wicker is topped with a lid bearing a most realistic-looking hen and half a dozen downy chicks, or a white-pasteboard box bears a pair of tiny chicks just emerging from their shells. Some of the handsomest bonbon-boxes are in the form of large Easter eggs of fine china, or of light wood covered with brocaded silk. These serve afterward as work-baskets or as catch-alls, and are as serviceable as they are ornamental; and it is discovered that it is the same with Easter bonbonnières as with other remembrances, the most serviceable are the most highly prized.

PEEBE WESTCOTT HUMPHREYS.

### AN EASTER SOUVENIR

This print, which represents a shadow picture of the face of Christ, may be copied by placing over it a sheet of blank writing-paper and tracing the lines very carefully in pencil or ink. The upper squares represent



the eyes, the lower triangles the mouth. It is to be cut out by following carefully every line, and in cutting the little triangles follow the inside of the lines or the lips will be heavy. Once cut it may be copied many times, and if desired can be made out of thin cardboard. Held before the evening light at a suitable distance to focus the rays properly there is seen a tenderly, luminous shadow of the beautiful, suffering Christ face.

The original of this curious souvenir was perfected after long and patient study by an aged monk in one of the monasteries of Europe, and is said to be the representation of an ivory painting in the cathedral at Antwerp. FRANCES BENNETT CALLAWAY.

### A BIT OF EASTER HISTORY

How the fearless Dean drove away Napoleon's army is a bit of Easter history well worth recalling, with its seasonable lesson of trust.

In the year 1799 the armies of the great Napoleon were passing over the continent of Europe like a mighty flood that swept all before it. One beautiful Easter morning the rising sun shone brightly on a little town on the borders of Austria, beautifully situated on the peaceful Ill, an affluent of the Rhine. As the sun rose higher there suddenly appeared on the heights above the town to the west of Feldkirch the glittering weapons of eighteen thousand French soldiers, commanded by Massena, one of Napoleon's generals.

There was no time for defense, but there was a hurried assembling of the town council, and it was decided that a deputation be sent to Massena, with the keys of the town and a petition for mercy. In the midst of the hurrying to and fro and the anxious consultation the old Dean of the church stood up tranquil as the morning, with no thought of fear in his brave old heart.

"It is Easter day," he said. "We have been reckoning on our strength, and that fails. Let us ring the bells and have service as usual, and leave the matter in higher hands."

Soon from all the church-towers of Feldkirch the bells rang out joyously, and the streets became thronged with worshipers on the way to church. Louder and more triumphantly pealed the bells, ringing out the glad message, "Christ is risen; He is risen from the dead!" The French heard the sounds of rejoicing, and Massena, concluding that the Austrian army had arrived in the night, broke up his camp, and almost before the bells had ceased ringing the French army was in orderly retreat, and not a soldier nor a glittering bayonet was to be seen on the heights above Feldkirch.

P. W. H.

### EASTER FLOWERS

Aunt Saby used to portion her small income very carefully into seven little bags. So long as she kept well she carried out her plan to the letter; but in a time of weakness and sickness, when she had to buy many medicines and have the best of food, she had not been able to maintain her flower-fund bag. With this flower fund she used to send a few flowers at Eastertime here and there to some friend in sorrow, and with the flowers she always sent sweet

notes of encouragement and cheer, of tender sympathy and hope.

In one of the bags which she portioned out she used to put what she called the Lord's money, for church support; in another she put mission money, but from none of the bags did she seem to derive so much comfort as from the flower-fund bag. It was empty the year of her sickness, and she studied and prayed over it. She was constantly asking, "How can I send my Easter flowers?"

She went to her Bible and read the story of the raising from the dead of the son of the widow of Nain. She got a paper which had Archbishop French's comments on the miracle. She read in her Bible, "He delivered him to his mother." Then she read what the bishop wrote, "So He who did this when the dead shall rise will deliver all the divided (if they fell asleep in Him)

to their own beloved for personal recognition and for a fellowship of joy and gladness and for a communion of love that will fill all hearts."

Aunt Saby thought she would read all the stories, not only of the raising of the young man, but of Jairus' daughter and of Lazarus, and see if she could offer those accounts as promises and pledges of reunion in the hereafter. It all seemed so plain to her that she closed her Bible and said, "I have been in the 'garden of God.' I have found there the rose of Sharon and the lily-of-the-valley. I will write out these thoughts to my friends, assuring them of Bible authority of meeting loved ones gone before."

She wrote the notes as she planned, saying, "This year I could buy no flowers, but I have been to the Bible, 'the garden of God,' and plucked flowers there for my Easter offering to your sad heart."

The answer of one expressed the thought of all who received Aunt Saby's notes: "Your Easter flowers are this year better than all others, because they cannot fade; they are everlasting."

MARY JOSLYN SMITH.

### REDEEMING THE TIME

The time is short—  
If thou wouldst work for God it must be now;  
If thou wouldst win the garlands for thy brow  
Redeem the time.

I sometimes feel the thread of life is slender,  
And soon with me the labor will be wrought;  
Then grows my heart to other hearts more tender;  
The time is short!

—Horatius Bonar.



COMPENSATION

There are smiles in the morn'g and tears at night,  
The wide world over;  
There are hopes in the morn'g and prayers at night,  
For many a rover.

There are tears unwept, and songs unsung,  
And human anguish keen,  
And hopes and fears and smiles and tears—  
But the blessings fall between.

—Louis Andrews, in Demorest.

THE WOMAN WHO DRIVES

THE woman who drives with whom I am the best acquainted, and in whom I feel the greatest interest, is the woman who lives on the farm, and who is more conversant with rural life and country and village highways and byways than with city pavements and avenue drives. I have said she is conversant with country and village highways and byways, but truth to tell, she is not one half so well conversant with all these things as she should be upon the average, for she has too often imagined that for her there was no place but home, and nothing but work, and she has made no particular effort in attempts to change her often self-appointed narrow surroundings into a broader line of living and manner of living her life, and allows herself to "drift" rather than to truly live.

For the woman who lives in the country one of the possible great luxuries to her is her horse and carriage, if she does not already possess it. Every well-appointed, well-managed farm should support for the housewife there her own individual equipage, and an equipage that carries beauty with it as well as convenience. It should be one of which she may be proud rather than ashamed. It should be strictly her own, to be used whenever she chooses to avail herself of the pleasure of a drive to town, to neighbors, or wherever she may wish to go.

As I said before, the woman who drives in whom I am most interested is the woman who (unfortunately) fortunately is not dependent upon a coachman, but upon herself. She becomes thus an independent horse-woman, or at least such she should become by all means. Circumstances of an unlooked-for character are apt to arise, and especially upon long or very frequent drives. To meet all these exigencies one must be prepared, and not only prepared with necessary articles of repair, but with a general knowledge of horses and how to manage them under different circumstances, and a further general knowledge of all those things that become a part of her equipage.

A very frequent examination of every part of the harness, to make sure that everything is in perfect shape and safe condition, is all-important. This every woman should as thoroughly understand as would any groom or other man who is accustomed to the daily care of horses and harnesses. If stitches are broken and the harness ripped in the least prompt attention should be given. At her next visit to the village she should call the attention of a harness-maker to the needed repairs, and he will attend to making everything safe and secure again while she is shopping or calling. If buckles or bridle-blinds are rubbing and irritating, see that they are made to fit comfortably. Do not allow the faithful steed to be annoyed by irritating harness fittings or trappings, and learn to understand quickly at first indications of annoyances what and where said annoyances are. See that the bit fits the mouth comfortably, and that the throat-latch is not too tight. A horse that is choked feels the discomfort constantly, and soon becomes restless and at last irritated beyond a control of temper. Discovering that something irritates him, step from the carriage and examine into the cause and make it right. Good-fellowship will then have been restored between the mistress and her steed, and it is one more step in securing or retaining the confidence and love of him and of strengthening the bond between them. A horse is quick to understand, and he is quick to give love for love. Look to his comfort and he will look to yours. Seldom does a woman's well-trained driving-horse betray the confidence placed in it. In times of danger he stands nobly by her and aids her. An incident in the experience of the writer will best illustrate, perhaps, and is as follows:

Several years ago a hurried trip was made to a city five miles from the farm, and time was not taken to exchange the work-harness for the carriage-harness. The span I had always driven was that day engaged in service in the field. Upon the return trip, in

starting down a very steep and difficult hill every tug fell from its fastening to the carriage upon the ground at the sides of the horses, and was dragging upon the ground. High-spirited and young as they were, they had been trained to a confidence in the voice of their mistress, and it took but a word to stop them. Looking back they seemed to ask if their driver was uninjured, and stood almost motionless. A hammer, monkey-wrench and other articles of use were in the carriage, and in a few moments everything was again secure.

So much for a well-trained span and for a perfect exchange of trust and confidence between driver and driven. And so much, also, for having been prepared to attend to needed repairs and possession of a practical knowledge of horses, harnesses and roads, and management at critical times.

If a horse shows sudden lameless, be very sure a pebble has been lodged in the sole of the animal's foot. Prompt measures are needed, and an animal that trusts its driver, even if a woman, will allow the foot lifted and examined without trouble. If a foreign substance or article is found it can be removed if one has an instrument of a pointed nature in the carriage. Wires, strong strings and straps or pieces it is well to have in some convenient, out-of-sight place in the carriage, to be used in case of unexpected break-downs. And always have a wrench or a hammer, or both.

For a woman's comfort and convenience a phaeton is to be desired rather than a high carriage. From the phaeton she can step out on a solid and safe surface in quick order should anything happen. Should she chance to fall out in time of accident she cannot be much injured, for she has so short or slight a distance to fall. Men as a usual thing do not take kindly to phaeton equipages. But women do. And the woman who drives and who lives in the country should have a phaeton and a to-be-trusted driving-horse. Neither can be listed as an extravagant luxury. They should be recognized among farm necessities.

Learn to drive with grace and dignity. Women have been termed awkward drivers, and much sport has been indulged in at their expense. Arms elevated, with lines in hand, give to a driver a very ludicrous appearance, and many women are found driving after such fashion. Let the arms rest lightly and easily at the sides and supported by the lap, and the hands grasp the lines firmly, but in an easy manner. Should a woman be driving an almost unmanageable horse, or one of run-away tendencies, she will of course be obliged to adopt occasionally tactics of another character. At such times she will of necessity lean forward, grasp the reins far out toward her horse, plant her feet firmly against the dash-board, and bring a sawing motion to bear upon the lines. At such times she takes no thought of her own general appearance. She is working desperately then with a much-desired and all-necessary end in view, that of saving herself and her carriage from destruction and regaining control of the animal that has undertaken to conquer and overrule her. Such animals are scarcely fit to place in the hands of women at all. Yet we have women who are entirely adequate to the occasion—women who are thoroughly horsewomen, and who can manage them as effectually as any man.

Teach the horse to know no fear. Teach him that unless he is on the track no danger can come to him from a locomotive or train. Talk to him and encourage him to believe that he may look to his driver to keep him from harm's way. He will soon become accustomed to being near trains without thought of danger to himself. A frightened horse is a pitiable object of concern. But with patience and care he may be taught to meet anything upon the road without fear, from a bicycle to a steam-driven threshing-machine, and from a drove of cattle or swine to a house on wheels. Our farm-horses are obliged to become accustomed to all these sights and sounds, and we cannot begin the training too young. The women who live in the country should become accustomed to driving, harnessing and hitching up, and they cannot begin too early to learn everything connected with the work. Many village maidens have married farmer boys and have become expert horsewomen. Others, however, have not learned to drive, and many have not known the luxury of owning and having their own individual horse and carriage. And it is all wrong. It is but a little thing to ask or expect. But when gained the privilege should be made a duty and a study, and the pleasure it will bring into the quiet life of the woman in the country should be accepted, cultivated and made the most of.

I do not advocate the neglect of home

and home duties in the remotest degree. But I do advocate more play and pleasure and less of the unnecessary, self-appointed hard labor that many follow out regardless of health and happiness. And I know of no one thing, or of combinations, that may bring so much happiness and pleasure and independence into the life of a woman who is surrounded with many duties and cares as the ownership of her own individual horse and carriage, and a thorough knowledge of everything in connection therewith.

Be prepared to harness and hitch up with great speed, even at midnight or other night hours. Lives have been saved just because of the ability of women to do these things. Sudden illnesses in the night have been thus soon relieved from the fact that a woman could soon be on her way to bring the physician and other necessary help, where but for such timely assistance on her part her husband must probably have died before help could have been secured.

Women who drive are becoming more numerous, but I cannot too thoroughly encourage all women to take up and master the art of excellent and independent horse-womanship.

ELLA HOUGHTON.

CROCHET POINT-LACE

ABBREVIATIONS.—Ch, chain; st, stitch; s c, single crochet; tr, treble.  
Make a chain of 27 stitches.

First row—1 tr in fourth st of ch, 1 tr in each of the next 9 st, ch 6, miss 6 st, s c in next 2 st, ch 6, tr in last st of ch.

Second row—Ch 8, tr on tr, 1 tr on each of the next 3 st of ch 6, ch 5, 1 s c between the 2 s c in previous row, ch 5, 1 tr in each of last 3 st of ch 6, 10 tr on 10 tr, ch 2; turn.

Third row—13 tr on 13 tr, 1 tr in each of



the first 3 st of ch 5, ch 2, miss 4 st, 1 tr in each of the last 3 st of ch 5, 4 tr on next 4 tr, 1 tr on each of first 3 st of ch 8, ch 2, 1 long tr (thread over hook twice) in same st the last tr was made in.

Fourth row—Ch 8, tr on tr, 2 tr in ch 2, 7 tr on 7 tr, ch 2, 3 tr under ch 2, ch 2, miss 3 tr, 13 tr on 13 tr, ch 2; turn.

Fifth row—10 tr on 10 tr, ch 2, 3 tr in ch 2, 3 tr on 3 tr, 3 tr in ch 2, ch 6, miss 3 tr, 7 tr on 7 tr, 1 tr on each of first 3 st of ch 8, ch 2, 1 long tr in same st last tr was made in; turn.

Sixth row—Ch 8, tr on tr, 2 tr in ch 2, 7 tr on 7 tr, ch 5, s c in ch 6, ch 5, miss 3 tr, 6 tr on 6 tr, 3 tr in ch 2, ch 2, miss 3 tr, 7 tr on 7 tr, ch 2; turn.

Seventh row—5 tr on 5 tr, ch 2, 3 tr in ch 2, 6 tr on 6 tr, ch 5, 1 s c on each side of 1 s c of previous row, ch 5, miss 3 tr, 7 tr on 7 tr, 1 tr in each of next 3 st of ch 8, 1 long tr in same st last tr was made in; turn.

Eighth row—Ch 5, miss 3 tr, 7 tr on 7 tr, 1 tr in each of next 3 st of ch, ch 5, s c between 2 s c, ch 5, 1 tr in each of last 3 st of ch 5, 6 tr on 6 tr, ch 2, 3 tr in ch 2, 5 tr on 5 tr, ch 2; turn.

Ninth row—7 tr on 7 tr, 3 tr in ch 2, ch 2, miss 3 tr, 6 tr on 6 tr, 3 tr on 3 st of ch, ch 2, miss 4 st, 3 tr on 3 st, 7 tr on 7 tr, 1 long tr in last tr that was made in the previous row; turn.

Tenth row—Ch 5, miss 3 tr, 7 tr on 7 tr, 3 tr in ch 2, ch 2, miss 3 tr, 3 tr on 3 tr, ch 2, miss 3 tr, 3 tr in ch 2, 10 tr on 10 tr, ch 2; turn.

Eleventh row—13 tr on 13 tr, 3 tr in ch 2, ch 5, miss 3 tr, 3 tr in ch 2, 7 tr on 7 tr, 1 long tr in last tr of previous row; turn.

Twelfth row—Ch 5, miss 3 tr, 4 tr on 4 tr, ch 5, s c under ch 5, ch 5, miss 3 tr, 13 tr on 13 tr, ch 2; turn.

Thirteenth row—10 tr on 10 tr, ch 6, s c on each side s c of previous row, ch 6, 1 tr on the fourth tr. Begin again at second row.

Make two open rows around the scallops thus:

First row—Slip st to center of first side of scallop, then ch 5 and s c in each of the next five loops; this brings you to the loop at point; ch 5, s c in same loop, then ch 5 and

s c in each of next five loops, then ch 2, 1 s c in loop of next scallop.

Second row—Slip st to center of ch 5, \* ch 6, 1 tr in fourth st of ch 6 for picot, ch 2, s c in next loop; repeat from \* four times. Now in point loop make ch 7, 1 s c twice, and finish this side of scallop like the other, making ch 2 between scallops. Finish upper edge of lace with ch 2 spaces.

Mrs. J. R. MACKINTOSH.

TREATMENT FOR COLDS

A distinguished physician who has practiced medicine for fifty years gives the following rules for treating a cold:

A hot capsicum foot-bath, temperature 111 degrees, for ten minutes; heat up twice during the time. For this bath add to the water one teaspoonful of capsicum made as follows: Steep for fifteen minutes one quarter of a pound of red pepper in one quart of vinegar, and bottle. The good housekeeper who wishes to be ready for every emergency should be sure to have a bottle of capsicum on her pantry shelf.

Before the foot-bath wet the head and face with cold water, and at the close of the bath rub from the knees down with cold water, and dry thoroughly. When the patient is comfortably in bed spread four pieces of heavy brown paper eight by ten inches with mustard and water stirred to the consistency of molasses. Cover these plasters with cheese-cloth, and apply for fifteen minutes, or until they burn warmly, upon the chest, abdomen, back, arms, forearms, thighs and legs. This is to prevent congestion, by starting an even circulation over the entire body.

For the chilly feeling which comes on with a cold take one teaspoonful of the following stimulant in a glassful of hot water: Aqua mamonia, one dram; pure glycerin, three ounces; fluid extract of zingiberis, one ounce. For a cold in the head a good remedy is to snuff menthol and vaseline mixed in an ointment after the following formula: Crystals of pure menthol, two drams; white vaseline, four ounces.

A good treatment of catarrh is first to snuff a little milk to which has been added a teaspoonful of the saturate solution of the chlorate of potash, and afterward put a little of this ointment, about the size of a pea, up each nostril. It clears the head like magic.

Colds are often brought on by shutting one's self up in close, illy ventilated rooms, by eating indigestible food, by getting overtired, by taking intoxicants, by anything, in fact, which leaves the blood in a low enemic state so that it is unable to resist disease. Ounce preventives are good warm clothing, nourishing food, temperance in everything, and plenty of exercise in the fresh, outdoor air, which sends oxygenized blood tingling all over the body. And we must not forget to take needed rest; even the tongue needs rest occasionally, and sometimes we sadly need rest from the ceaseless clatter of somebody else's tongue. A feeble person has been known to be taken with pneumonia and die simply because a heedless caller talked too much by half an hour.

F. B. C.

DISPOSING OF MAGAZINES

Into nearly every household several magazines find their way each month, are read, tossed aside, or a pretense made of saving them for future use, though they are seldom looked at after their first freshness has worn off, as others take their place. It is a pity that this good reading matter is wasted in this way when it could give so much pleasure and profit to others.

Nearly all the hospitals are very glad of reading material; most churches will take it and distribute it or send it away in missionary boxes, and some of your own friends and acquaintances whose moderate circumstances do not permit their steady indulgence in current literature will without doubt be glad of the magazines each month. I do not mean for you to wait until they are out of date and untimely, though even then they contain much that is still readable.

Consider it a privilege to be able at the end of each month to pass on your current literature to some one, and a little tact in the act of giving will remove any scruples they may have about accepting the gift, and will avoid any appearance of charity. It is not charity, of course; it is simply good-fellowship, and should be given and accepted in the same spirit.

EMMA LOUISE HAUCK ROWE.

[HOUSEHOLD CONCLUDED ON PAGE 19]



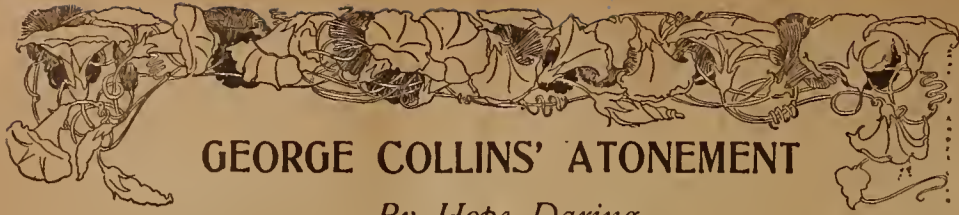

## GEORGE COLLINS' ATONEMENT

By Hope Daring

### CHAPTER IV.

#### THE PASSAGE OF YEARS



NOT guilty, your honor."

That was all George heard. He was conscious of a feeling of wonder that the verdict should afford him a strange kind of pleasure. He might not be guilty, nay, he was not guilty of intentional wrong. Yet his was the hand which had sent the drunken man to his death.

He was soon surrounded by a throng whose congratulations were heartily given. He saw Lilian leave the room, and was asking himself if he could not slip away unnoticed, when Judge Harmon touched his arm.

"Collins, Mrs. Kennedy wishes to speak to you."

Much to George's surprise she greeted him warmly.

"I want to tell you, sir, as how I'm glad it was settled as it was. Punishing of you wouldn't have brought Bill back, and you've been real free-handed like to me."

"Thank you. Your words are a great comfort to me. I shall drive out to see you to-morrow, as I may leave the country, and I want our business arranged while I am here."

"I'm sure you are very good, and I thank you kindly, sir," she began, volubly; but Judge Harmon saw how pale George was growing and hurried her away.

George was sick and faint. The judge drew the young man's arm through his own.

"The air will revive you. This has been a hard day for you."

With kindly tact Judge Harmon shielded his companion from observation. When they reached the street and George felt the soft snow-flakes, like caressing fingers, brush his cheek, something of his old vigor came back to him.

"You must think me very weak," he began; but the judge stopped him.

"Indeed, I think you have shown remarkable mental and moral strength for one in your weak physical condition. Collins, what do you intend doing for Mrs. Kennedy?"

"I shall send her a certain amount yearly. I fear I cannot make it more than three hundred dollars."

"More than that! Half that will be wealth to her! Pardon me for speaking plainly, my boy, but I am interested in you. Mr. Larr has told me all about your circumstances, and I know you cannot afford it."

"I must work and earn it, sir. I thank you, Judge Harmon, for your interest. You have been a true friend to me. I cannot lay aside my responsibility regarding this family. To care for them is all the atonement I can make."

They talked for a long time. The judge tried to lead George to speak of his plans for the future, but the young man's lips were sealed. Indeed, it would have been impossible for him at that time to speak with any certainty of what he would do. All delight in life and in what he had chosen as his work was dead.

The next morning he again drove out to the home of Mrs. Kennedy. Somewhat to his surprise he found the house cleaner and containing a few simple comforts which had been added since his first visit. The baby was playing on the floor. Upon George's inquiring for the little girl Mrs. Kennedy looked confused.

"I hope you won't take it amiss, sir. I sent her to a neighbor's. She's big enough, is little Bee, to ask lots of questions, and somehow she can't seem to understand 'bout Bill."

A dull red flush stained George's pale face. "You did right," he said, in a hard voice. "It is best that she should know as little as possible about this matter."

He proceeded at once to a discussion of the business which had brought him there. When Mrs. Kennedy learned his intention she opened her eyes in amazement.

"Three hundred dollars a year! And until the children are old enough to take care of themselves and me! Sure and it's more money than I ever expected to have. What does make you so good to me, Mr. Collins?"

He answered her coldly. Somehow her delight jarred upon him. Was her love so shallow that she forgot what this money really meant?

When he arose to go he extended his hand. She placed hers in it.

"Please, sir," she said, in an unsteady voice, "don't grieve any more over what can't be helped. It don't do any good."

He thanked her for her thoughtfulness and left the house. On reaching Lamont he made arrangements to leave on the next train. There was only Judge Harmon and a few others who had shown him special kindness to bid farewell.

"I hope I shall never see the place again," he said to himself, as the train sped on its way, soon leaving Lamont far behind. "My stay there has changed my life. I will go home, rest for a week, then get my business in shape and go to work."

It was several weeks before he was able to carry out this program. His strength came back slowly. At last, however, he was able to attend to his business affairs.

It had been necessary for him to raise a large sum of money to meet the expenses of his trial. This Mr. Larr insisted on loaning him, taking George's note for the amount.

George saw that it would be difficult for him to pay this money and what he had promised Mrs. Kennedy, to say nothing of the improvements he had hoped to make upon the farm. He set his lips close together in the old determined way. He would not sell his home, and he would meet these obligations. Just how he did not yet see, but the way must be found.

He made arrangements for Mr. Larr to oversee the farm, should his contemplated absence prove a long one. All desire for the literary, intellectual life he had once craved had passed from him. He desired nothing now but action, to work each day until physically too tired to do aught but fall into a dreamless sleep when the day was done.

George Collins shrank morbidly from the memory of the life which had gone out because of his act. Closely following this had come first the dereliction of Stanley, and then the utter falseness of Lilian. With a faulty reasoning the young

work. He turned his back upon the olden dream of journalism; manual labor was to be his choice.

A letter from Mr. Larr to an old friend aided him in finding work. In a few months he became a mail-carrier. It was a strange position for a young man who had less than a year before graduated first in his class from an influential college.

He toiled on doggedly. When his day's work was done he shut himself up with his books. Reading and study were his only recreations.

This life went on for two years. Then after a brief visit to Loyd, where he found everything in excellent order, he left for Colorado. Here he engaged in silver-mining. Although meeting with no phenomenal success, yet steady, persistent labor at last brought its reward.

George Collins remained in the West five years, and then returned to Loyd. He found few changes. Mr. Larr had managed the farm well. George's debt to him had been canceled long before and the payments to Mrs. Kennedy met promptly. George had sent home money for improvements, and he planned to spend much more in the same way. The old farm should be one of the best in the state.

Mr. Larr hoped George would be content to remain at home, but it soon became evident that this was not the young man's plan. The years had greatly changed him. He had grown heavier, and his face was darkened by exposure to the Western winds, while the look of open-hearted frankness had been replaced by one of proud reserve. He was taciturn, apparently taking little interest in the lives of those about him. Mr. Larr was un-

mail in country districts. These he let out to other men, making a profit from each.

His life was a very quiet one. He had always continued his habit of study. Avoiding all society, he spent his evenings with his books, and occasionally contributed an article to some scientific periodical.

As time went by he fell into the habit of going for a few days to the farm and spending the rest of his annual vacation in travel. Twice he crossed the ocean. Once he spent a month in England, and again he went for a short trip on the continent. While he had many acquaintances, he had no friends. His life was clean and free from all that savored of dishonesty, but narrow and self-centered.

One spring, fourteen years after the tragical death of William Kennedy, George awoke to the fact that he was ill. He was weak, nervous and had no appetite, and was unable to sleep. Finally he was obliged to consult a physician.

Doctor Evarts looked him over carefully and asked many questions about his mode of life. When he learned that George had been giving all the time possible this winter to an exhaustive study of German metaphysics he nodded his head.

"Very simple, Mr. Collins. You have overworked your brain and taken too little exercise. Now I am not going to dose you with drugs. Leave the city and live out of doors this summer. Study Nature instead of books, and when autumn comes you will be your old self."

George was forced to admit the wisdom of this advice. He resigned his position, and the day his resignation went into effect he received news of the severe illness of a man whom he had hired to carry the mail on one of the country routes. Acting on a sudden impulse, George packed his clothes and a box of books and went out to the little village of Holland, purposing to carry the mail himself for a time.

Holland consisted of a church, school-house, store, post-office, blacksmith-shop and twoscore of dwelling-houses. Early each morning the man who carried the mail left the village. He drove a team hitched to a quaint-looking covered "stage." His destination was Durraid, twelve miles distant. Here he dined, and returned to Holland late in the afternoon.

In a week's time George was domiciled in a tiny three-room cottage. The people of Holland knew nothing about him save his name. He took his breakfast and supper with a family near. There was much harmless gossip concerning the grave, quiet man, who so skilfully evaded all questions concerning his past. There were also many rumors concerning the house, whose principal furniture was declared to be books.

From the first the life had a curious charm for George. It was April when he came to Holland. The country roads over which he drove were already bordered with wild flowers, and the maples were fringed with crimson pendants. Soon the air was alive with the music of mating birds, and the fruit-trees were bending under their weight of blossoms.

George Collins was losing the burdens of years. His heart was filled with the joy of the springtime, and he often found himself humming half-forgotten college songs as he drove along. He began to be amused by the queer people who sought his wagon as a means of conveyance. Almost unconsciously he began to jot down bits of dialogue and humorous and pathetic studies of the life, about him.

From this the passage to the loved work of years before was easy. The summer was only half gone when he dispatched a short story to a leading Eastern magazine, and watched for the news of its reception as eagerly as when fifteen years before he had dreamed of the great things to be done by his pen.

A kindlier light came into his dark eyes. He was living close to the heart of Nature, and although he had forgotten the half-jesting remark made to Stanley Hart so long before, Nature was surely rewarding him by making him "a part of herself."

One hot day in August George reached Holland tired and dusty. He cared for his team, changed his clothes, ate his supper, and hastened back to the house, anxious to devote the half hour of daylight remaining to copying a second story which had occupied him for some time.

He was only fairly at work when a rap sounded on the kitchen door. George hesitated. The temptation was strong to ignore the interruption, but finally he rose and crossed the room.

The door stood open, the screen being hooked on the inside. Two women stood on the steps, and George silently resolved that the interview should be conducted without their entering.

"Ah, Mr. Collins, I believe!" said the elder, a pale, stooping woman of middle age.

George bowed coldly.

"I am Mrs. Slater, and this is my daughter, Bernice. We called to see you about—"

Here she stopped, pressed one hand to her side, and gasped for breath. The young girl stepped forward, concern depicted on her face.

George hurriedly opened the screen door. "Bring her in, Miss Slater; this way;" and he helped lead the woman to the sitting-room, placed her in a chair, and stood helplessly while the daughter fanned her with a newspaper.

"What can I do? Is she in any danger?" he asked.

"Yes; it is her heart. Have you any liquor?"

He hastened to bring a small flask of brandy. The girl moistened her mother's lips, but the woman sank back apparently lifeless.

"Mama, mama!" the girl cried, an agony of fear in her voice. "Oh, mama, speak to me!"

George came to her side, self-possessed and calm.

"Let me lift her upon the bed," and suiting the action to the word, he took the slender figure in



"HE PAUSED FOR A LAST LOOK AT THE OLD HOME"

"THE WOMAN SANK BACK APPARENTLY LIFELESS"

man judged all the world by these two. Perhaps time would restore the serene poise of his nature; but for the present it was gone.

He resolved to go to Chicago and look for work. On an evening early in April he returned from a last visit to Mr. Larr. The next morning he was to take a train for the distant city.

George walked home. His strength had returned to him, and the three-miles' walk was a pleasure. Reaching a little eminence from which the farm-house was visible he paused for a last look at the old home.

The grounds were in perfect order. From the windows of the dining-room and kitchen lights gleamed hospitably out. Behind the house the sky was still flushed with the soft pink and violet tints of a spring sunset. George knew he would find supper waiting him, and a hearty welcome from the loyal Mr. and Mrs. Blake. Some tender and sweet memories stirred in his heart. After all, might not life mean much for him?

It was one of the crucial moments which rarely come; one of the moments when man chooses a self-denying integrity of purpose or when he selfishly surrenders his opportunities for true living because of the clouds which hover over his path. Alas! that George Collins should choose the latter! He turned away from the fair picture spread before him with a derisive laugh.

"It is my home, and the love for it is all I have left. But I owe too much to the memories of my parents to bring my life of unrest and bitterness here. Years of atonement may bring peace; if not, I will be a wanderer all my days."

The next morning found him speeding westward. Upon arriving in Chicago he sought out a cheap lodging-place, and set about looking for

able to tell him aught of Mrs. Kennedy save that the receipt for the money sent her at Lamont was promptly forwarded each time. When the old lawyer volunteered the information that the elder Hart was dead and that his son had succeeded to his father's practice George listened indifferently.

"I have ceased to think of them," he said, letting his eyes wander over the fields of waving corn and the sunny pastures visible from the vine-draped porch where himself and Mr. Larr were sitting. "Stanley Hart did me one kindness, after all. He taught me that my Utopian ideas had no existence."

The old lawyer shook his head. "Some day, my boy, you will see your mistake. I hoped it would be ere this. Trouble came to you, George, and instead of making you better it soured your nature. It is possible for you yet to realize the dreams of long ago, to live a life that shall be a blessing to your fellow-men. God grant I may be spared to see you with wife and children happily established in this old home."

George did not reply. He turned his head aside, and for a time there was silence.

He lingered at Loyd for several months. At last he went to Chicago. Again he sought work, but not as before, for manual labor. His mind was becoming active and he thirsted for different things.

A renewal of his old acquaintances in the postal department brought him a position in an office at a fair salary. As he became interested in his work he began to take contracts to carry the



his arms, strode into the adjoining room, and laid it upon his bed.

Bernice loosened her mother's dress and bands. Soon Mrs. Slater's breath came stronger and more regularly. In a few moments she was able to swallow a little brandy and water. She smiled faintly up in her daughter's face, then her eyes closed in sleep.

The girl drew a breath of relief. "She will be all right when she wakens."

George quietly left the room. A half smile was on his lips. What next would happen in this strange, unconventional life?

A few moments later Bernice emerged from the inner room, softly closing the door behind her. The light was still bright enough so that George noted, for the first time, her face. She was small, slender and fair. Her cheeks were flushed with the pink of perfect health, her large, bright eyes were blue, and her hair, coiled in a compact mass at the back of her shapely head, was raven-black. George's keen eyes saw also her tender scarlet lips, as well as her beautifully molded but tanned hands.

"I don't know how to apologize for the trouble we are making you," she began, her face coloring deeply. "It is a most unusual way of calling on one's neighbors."

"Pray do not think of it in that way," George said, earnestly. "I am most happy to be of service to you. Was there not some matter of business regarding which your mother wished to see me?"

His matter-of-fact tone set her at ease. She took the chair he brought forward, bowing her thanks. For a moment her eyes wandered about the book-lined room, then she began speaking.

"My mother and I moved to Holland three days ago. Mama owns the house next to this, although we have always lived in an adjoining state. My father died a few months ago, and mama's health has been very poor ever since. For the next year I am to teach the school in the Hall district, three miles north of here. We called to see if I could go and return each day with you."

"Certainly," George replied; "but you will have to start early in the morning."

She nodded. "I understand. It will be the best thing for me to do, as I cannot bear to leave mama alone at night."

The conversation drifted to other subjects. George saw that her position was an embarrassing one and tried to lead her thoughts from herself. When he lighted a lamp she spoke of his books, and rising, began to make a tour of the room, examining the titles with eager delight.

He saw that she had been well educated and was a careful reader of good literature. From the scientific works and the Latin and German books she turned away, but she lingered long before the volumes of poetry, history, essays and fiction.

"I never dreamed there was such a library in this town," she had commenced, when a faint voice called, "Bernice!"

She hastily joined her mother. After a little the two came from the bedroom. Mrs. Slater was very pale. She thanked George with a diffusiveness very different from Bernice's simplicity. They soon took their departure, declining George's offer to accompany them on the ground that it was not necessary.

"A charming girl," he thought, as he re-entered the room, after seeing his guests pass through the gate. "Her mind is alert and well balanced. In many respects she is far superior to her mother. Now I will see if I can again take up my work."

[TO BE CONTINUED]

## FLORENCE DURING HOLY WEEK

BY LOUISE OHL WARDER

It is Holy Week in Florence, and next to the splendors of Rome at this great religious festival Florence stands with her peculiar customs. We have been on the qui vive all week, fearful lest we miss something of interest, and prepared to see all that is to be seen. The "city of flowers" rightly deserves its name at this season, for from early in March the women haunt the corners of your own door-steps with baskets loaded with the loveliest varieties in profusion; and with a little judicious jewing down you can for a franc carry off a bunch as big as yourself. Roses, anemones, violets, tulips, poppies, and narcissus in white and yellow and the loveliest faint pink, how we revel in them, and how delicious they are!

Holy Thursday it is the custom to build in the churches, usually in a chapel or side-aisle, a sepulcher. This is done by building up the entire space with flowers, using, alas, artificial ones chiefly, and sometimes tinsel moustrosities. In some of the poorer churches it is pathetic to see the little green shrubs and paper flowers, and this is one of the curious Italian customs, that here, where flowers are as cheap as air, artificial ones are used in preference, both at Christmas and Easter. Usually the altar-vases are huge, flat structures of artificial green, with paper roses, pink, white and red, stuck in here and there. No human being could mistake them for anything but artificial, but vases and all are put safely away, to be used year after year at the same festival.

But to go back to Holy Thursday. In some of the sepulchers is a figure of the dead Christ surrounded by floral decorations, and sometimes the cross, nails, spear, crown of thorns and sponge appear. One very curious and favorite decoration is a white grass, looking as if it was grown in a dark cellar, giving the effect of silver moss, and really very pretty. Sometimes it is massed into a small mound, surmounted by a miniature cross and ladder, symbolical of Calvary.

Outside each church the old women sell little switches or wands covered with strips of colored papers to represent the staves and scourges that

struck our Lord. We reached the cathedral in time to witness the washing of the feet. In front of the high altar in the chancel was an elevated long bench, on which were seated twelve figures in pure white linen robes, with white caps or cowls on their heads. Presently came the procession of priests, choir-boys and acolytes, with the archbishop walking in the midst under a canopy bearing the Host. After installing the archbishop in his throne the priests celebrated mass, and somebody, whose voice was completely lost in the vast cathedral filled with a crowd of incoming and outgoing worshippers and sight-seers, addressed the assembled multitude, after which the long-expected moment arrived, and the twelve old beggars put up their old feet and drew off long white socks. Then came a priest bearing a basin of water, and the archbishop came down from his throne, and following the example of our Lord on that first Maundy Thursday, washed the feet of the twelve; and twelve little acolytes came along behind and wiped the feet, and then proceeded to wear the towels around their necks.

On Good Friday the entire church inside and about the entrance is draped in black. The services are wonderfully solemn and impressive. Usually there is no light save the glimmer of a few candles on some of the altars, and solemn minor chords peal forth from the organ to break the death-like silence.

Saturday brings the most peculiarly Florentine custom. It is the firing of the Pazzi car in the Piazza del Duomo with fire lighted from the high altar of the cathedral and borne through the length of the church and out into the square by a white dove. This custom dates from the time of the first crusade, and occurs in connection with the name of one of the great old Florentine families. Indeed, each street, each corner, each palace has some emblem. The Medici balls, the Strozzi crescents, the Pazzi dolphins, all figure on buildings, as well as demons, and bats, and garlands of stone, and vases of fire, which adorn the last-named palaces. To return to the custom which, too, bears the Pazzi name, it seems that a Florentiner, Ranie by name, performed great deeds of valor in the storming of Jerusalem, and in reward thereof was permitted by Godfrey de Bouillon to carry home a torch lighted from the fire at our Savior's tomb. He, fearing that the wind would blow it out as he rode along on horseback, turned his face to the horse's tail, and so shielded by his body bore his torch in triumph to Florence. En route the people who saw him pass called out after him "pazzo," or fool. From this came the family name of Pazzi. Another story of the origin of the custom is that besides the torch he brought back from Jerusalem flints from our Savior's tomb. These were put into the church of San Biagio, where the fire from the torch was kindled, and later the flints were transferred to the Santissimi Apostole, whence they are carried each year to the cathedral on Holy Saturday in the arms of a member of the Pazzi family. The old custom was to extinguish all the fires in Florence, and on Holy Saturday the archbishop would take the flints and strike from them a new fire. Each family would light a candle and make a new fire for themselves. So the custom grew, until now it is their greatest festival.

Unfortunately we are a little late in arriving at the scene of action, but soon crowd our way into one of the aisles and look around us. Every corner of the cathedral, the steps leading to it, the piazza, and every window and balcony within view is crowded with men, women and children. Such an anxious, hustling, noisy mass of people. There are the Lung Arno beggar and Marchesi side by side, the contadinas, or country women, shopkeepers nudging and jostling each other. Finally we see the Pazzi car drawn by two white oxen outside the door, and the excitement grows intense. At the stroke of noon, the choir chanting the Gloria in Excelsis, the archbishop strikes fire from the sacred flints, and lights the fuse. Then the dove, like a comet with a fiery tail, flies through the church, every eye meanwhile watching it with keenest anxiety until it touches the car of fireworks, and then an ear-splitting din follows, both inside and out. The people have forgotten that service is still going on, to judge from the noise of excited voices, for the dove has flown straight, and the crops are therefore an assured success. There are blind persons all about us hoping some of the sacred sparks may light upon them and restore the sight, and I see also as a most touching picture of devotion a little contadina who devoutly tells her beads, not daring even to raise her eyes during the miraculous flight.

The whole ceremony lasts only about fifteen minutes, then the car is taken to its own little house in a side street, where we follow it later. We are too late to see anything, however, but two huge closed doors bearing the flaming advertisement of a well-known bicycle. Verily the old and new.

## BAY-RUM, REAL AND FALSE

It is not unlikely that among the many Americans who are going to Porto Rico in the confident expectation of being able to make their fortunes in that rich tropical island a few may turn aside from the well-beaten tracks of the sugar, coffee and tobacco trade, and give their attention to a much smaller industry, which, although it has existed for some time, has never attained large proportions there. This is the manufacture of bay-rum, a product which, when genuine, appears to belong solely to a few West Indian islands.

There are probably few other articles of commerce in which the amount of the imitations sold and used is so amazingly in excess of the quantity of the real stuff. "Bay-rum" which has never been within a thousand miles of a bay-leaf, and which has not even rum in it, to justify the latter half of its name, is the kind used in most places in this city and throughout the country. It is made

of alcohol as a foundation, with various oils and spicy substances—such as cassia, spearmint, pimento and lemon—mixed in to give it the necessary odor and body. Sometimes the real bay-oil is secured and mixed with the alcohol, but comparatively little of this is done, because the bay-oil is expensive to import. Besides, the makers of bay-rum in the West Indies are not anxious to sell the oil alone, knowing that it hurts the sale of the bay-rum which they produce. The leaves cannot be brought to this country, for when dried the oil in them becomes rancid and wholly useless for making bay-rum.

It is not difficult for any one who is familiar with the fine fragrance and good qualities of the genuine to distinguish it from the imitations, but so little is known in general about the article that people accept anything as such which bears the label. There are differences in the quality even of the imitations, as might be supposed. Some druggists prepare a passable sort of stuff—not bay-rum, but at least pleasant to the sense of smell, and many, many degrees above the horrible, sticky liquid with which the ordinary barber provides himself.

From the Island of St. Thomas, "very fair and full of promise"—as Bret Harte called it many years ago—comes practically all the genuine bay-rum used here. It is made there and brought to this country by Mr. Michelsen, a Dane, whose experience in its manufacture dates back thirty years and more.

"You see," said Mr. Michelsen, "what they make costs them only the actual value of the alcohol and other ingredients, which is small, and the internal-revenue tax of \$1.20 a gallon. Now, added to the cost of making the bay-rum and shipping it here, I have to pay a duty of \$1.50 a gallon. That makes it impossible to sell it at retail for less than \$2.50 a gallon. The imitations can, of course, be sold for much less, and as long as many people are satisfied with them, not knowing the difference between them and real bay-rum, the manufacture of them will flourish."

It is a peculiar fact, which has never been satisfactorily accounted for, that the bay-rum made in St. Thomas is better than that produced anywhere else in the West Indies. Porto Rico and the British island of Dominica, in the Windward group, are the chief of the other places where it is made, but in neither of these islands has it ever attained the quality of the St. Thomas product.

The bay is a handsome tree with dense foliage, somewhat resembling the linden in its general appearance. It grows to a great height, and its trunk is frequently two feet in diameter. Mr. Michelsen calls it a "true child of the wilderness," because of the fact that while it flourishes in its native forests on the hillsides, it cannot be cultivated successfully, even when the young saplings are transplanted with the utmost care.

"I have seen huge bay-trees on the mountains," said Mr. Michelsen, "growing luxuriantly, although their roots were scarcely in the ground at all, but were clinging to the bare rocks. They must have lived almost entirely on the moisture with which that tropical air is always saturated. Then I have tried to make the bay-tree grow in my garden in St. Thomas, and in spite of all I could do it would die before it grew to be six feet high. It will not be domesticated. Probably the soil of a garden is too rich for it, after the clay and marl of its natural bed. As for making it grow in this climate, that is absolutely out of the question. I have made the experiment here many times."

Owing to the evenness of the West Indian climate the bay-leaves can be cut at all seasons of the year, but the heaviest and finest crop is obtained in July, when the foliage is in its prime. The leaf is usually from three to three and one half inches long, and from one to one and one fourth inches in width. It is thick, like a laurel-leaf, which in its elliptical form it resembles, though its smooth, dark-green surface has a brilliant luster which is more like that of the rubber-plant. The makers of bay-rum in the islands do not usually own the land on which the trees grow. They merely buy the leaves from the negroes, who pick them, and who pay the owners of the land something for the privilege of doing so. Mr. Michelsen pays half a cent a pound for all the leaves which the negroes can bring in. They come not only from St. Thomas itself, but from St. John and some of the islets in the neighborhood. Men, women and children engage in the work, and as a West Indian negro can live comfortably, according to his standards, on about ten cents a day, the pay which they receive is considered good. The men climb the trees, and with their machetes—the popular tool of all work in the islands—cut off the ends of the branches bearing the fresh, young leaves. These drop to the ground and are gathered by the women and children into bags, in which they are taken to the distillery.

After the bay-leaves have been sorted and the poorer ones thrown out the others are put with water into an ordinary still. Under the influence of the heat the volatile bay-oil escapes with the steam through the outlet tube at the top of the boiler, and the mixture, being carried in spiral pipes through a vessel of cold water, is condensed into liquid form. A pipe at the base of the condenser affords an outlet for the liquid, which is then poured into glass vessels holding five gallons each. In these vessels the oil gradually separates from the water, rising to the surface by reason of its lightness. An opening at the bottom of the vessel allows the water to run off, and as this proceeds more of the mixture is poured in at the top until the water is all gone and the vessel is entirely filled with the oil. This oil contains, of course, some dirt and foreign matter, but that is all driven off in the next process—its distillation with pure Sauta Cruz rum. This second distillation completes the bay-rum, which is then ready for use. It is a product which does not change with age, either to improve or deteriorate, and if kept

tightly corked up will remain in precisely the same condition for any number of years.

Except that part of his stock which is for consumption in the island, and which he bottles directly there, Mr. Michelsen puts the bay-rum into barrels for shipment to this country, bottling it upon its arrival here. When put into the barrels it is almost colorless, but it acquires a pale straw tinge from contact with the wood. It is so sensitive to the slightest outside influence that great care has to be taken with regard to the bottles which are to contain it. If the glass is of a kind that has been treated with certain chemicals it cannot be used, for no amount of cleaning can prevent it from affecting the bay-rum and causing it to become flaky and impure. Most of the product which is not exported to this country is sold among the islands—where the negroes will even drink it in default of anything more desirable—and to the officers of war-ships and other vessels which touch at St. Thomas. Comparatively little is sent to Europe, where bay-rum is not much known.—New York Tribune.

## CONCERNING GLOVES

Articles of dress change with the ebb and flow of fashion, but gloves retain their place through all the movements of time. They cover the hands of brave soldiers and fair ladies to-day just as they covered the hands of the beautiful dames and gallant courtiers of long ago. The glove is in its way a memorial of that age of chivalry about which poets sing and historians write, for it was the symbol of power, the gage of defiance and the token of love. The story of the part it played in the drama of human development would be as fascinating as any novel if it were undertaken by an author of competent knowledge and skill.

It is generally believed that gloves date as far back as the time of Boaz and Ruth, and that by means of them all changing or redeeming of property was confirmed. It was the custom for a man to pluck off his glove and give it to his neighbor for a testimony. While Ruth (iv. 7) is rendered in our authorized version of the Bible by "shoe" instead of "glove," there seems to be little doubt among archaeological scholars that it is a mistranslation. In the Chaldaic paraphrase the word is rendered "the case or the covering of the right hand," and even up to the present day it has been customary among Eastern races for the seller, at any sale of goods or exchange of lands, to give the purchaser a glove by way of sealing the bargain, instead of the small coin which answers the same purpose at sales in some Western countries. Though there may be some doubt about the place and use of the glove among the Jews, there can be no doubt concerning its adoption in Greece and Rome.

The classics abound in references to it. Homer describes Laertes as wearing gardening-gloves to protect himself from thorns. Xenophon laughs at the luxurious Persians, who were effeminate enough to keep their hands warm with gloves in cold weather. Musonius, at the close of the first Christian century, used to grow eloquent in his fiery denunciations of people in good health who would insist on clothing their feet and hands in soft and hairy coverings. But the caricature of the satirist and the invective of the preacher were as effective in driving gloves away as Mrs. Partington's famous mop was in wiping up the Atlantic. Gloves suited the fancy and comfort of the people, and they secured a hold which the passing of the centuries has been powerless to weaken.

Everybody knows that the gauntlet was an emblem of defiance in the days of chivalry. The challenger took off his right-hand glove and flung it upon the ground. Whosoever took it up thereby accepted the challenge. The glove was, strange to say, a memorial of friendship as well as a challenge to battle. It was frequently worn in the cap as a symbol of the loving regard of some special friend. An old chronicler speaks of some knight who wore the glove of "his darling" on his helmet. Another says of the heroes of Agincourt that "one wore his mistress's garter, and one her glove." Every reader of Shakespeare will remember how the sagacious doctor from Padua, whose pleading was so successful in the case of Shylock against Antonio, refused to accept anything from grateful Bassanio except his gloves, which he promised to wear for his sake.

The good old days of chivalry are gone, to return no more. Gallant young men cannot now hope to win a pair of spurs to lay at the feet of their lady-love. The times have changed, and we have changed with them. They now lay gloves at the feet of maidens fair instead of wearing them on their head-pieces as they go out to fight cruel oppressors and dreadful dragons. It is a much easier and more pleasant, though less romantic performance. A few generations ago the process was reversed; the young lady had, under certain circumstances, to give gloves to the young gentleman. It was only necessary for him to catch a glimpse of the new moon, reveal the interesting fact to the first maiden he met, and with a kiss claim a pair of gloves. If in his travels on a summer afternoon he caught a damsel sleeping under a tree, he had the privilege of stealing a kiss from her and demanding a pair of gloves. The unreasonableness of the claim helped to sweep it out of existence. The ladies thought the kiss was sufficient without having to pay the fine, and gentlemen are gallant enough, even in our unromantic time, to understand that a kiss is better than a pair of gloves.—New York Ledger.

If we would just stop to think we would realize that the interest we take in our neighbors' affairs is out of all proportion to their merit.—Puck.



NOW READY

# McMASTER'S FIFTH VOLUME HISTORY OF THE PEOPLE OF THE UNITED STATES

By Prof. JOHN BACH McMASTER  
Vol. V. 8vo. Cloth, with Maps, \$2.50

The fifth volume of Prof. J. B. McMaster's "History of the People of the United States" deals with the close of Monroe's term, the administrations of John Quincy Adams, and the stormy opening years of Andrew Jackson. It describes the development of the democratic spirit, the manifestations of new interest in social problems, and the various conditions and plans presented between 1821 and 1830. To a large extent the intimate phases of the subjects which are treated have received scant attention heretofore. A peculiar interest attaches to the various banking and financial experiments proposed and adopted at that time, to the humanitarian and socialistic movements, the improvements in the conditions of city life, to the author's full presentation of the literary activity of the country, and his treatment of the relations of the East and West. Many of these subjects have necessitated years of first-hand investigations and are now treated adequately for the first time.

D. APPLETON & CO., New York

## Reversible LINENE Collars and Cuffs.

Stylish, convenient, economical. Made of fine cloth, finished in pure starch, and exactly resemble fashionable linen goods. **No Laundry Work** When soiled discard. Ten Collars or five pairs of Cuffs, 25cts. By mail, 30cts. Send 5 cts. in stamps for sample collar or pair of cuffs. Name size and style.

REVERSIBLE COLLAR CO., Dept. C, Boston, Mass.

RUBENS DANTE TASSO MURILLO ANGELO RAPHAEL

## \$1000 for BOYS

Send ten cents for three months' trial subscription to

### THE AMERICAN BOY

A practical magazine for boys. Departments: Short Stories, Successful Boys, What Boys are doing, Talks on Business—(Insurance, Savings Banks, Book-keeping, etc.), Boys as money-makers, The Boy in the office, store, factory, home, church and school, Games and Sport, The Boy's Library, The Boy Journalist, Printer, Collector—(Stamps, coins, curios, etc.), Photographer, Mechanic, Scientist, Orator and Debater, Boys and Animals, Prizes and Puzzles. Interesting, instructive, pure, elevating, inspiring.

\$1000 in Cash Prizes and a choice from 300 elegant premiums given for subscribers. The magazine canvasses for itself. You need not show it. The best paper ever issued for boys. References in every city. \$1.00 a year. Trial three mos. sub. for 10c.

SPRAGUE PUBLISHING CO., 186 Maj. Bldg., Detroit, Mich.

## A Way to Change Your Work

Prepare for a better position without neglecting your present work. Our students advance in salary and position while studying. 150,000 students and graduates

### TAUGHT BY MAIL

Mechanical or Architectural Draughting; Electrical, Mechanical, Steam or Civil Engineering; Architecture; Surveying; Book-keeping; Stenography, &c.

Established 1891. Capital, \$1,500,000. Write for circulars.

The International Correspondence Schools, Box 868, Scranton, Pa.

## SOLID GOLD

and gold filled watches are the only kind that **WILL WEAR AND KEEP THEIR COLOR.** We illustrate here the best and handsomest genuine gold filled watch in the world for the money. Double hunting case superb solid gold pattern of engraving. Magnificently finished jeweled works, stem wind and set and guaranteed for 20 Years. Equal in appearance to the average

### \$35.00 WATCH

Cut this out and send it to us with your name and address and we will send the watch to you by express for examination, you examine it at the express office and if as represented pay express agent our special introductory price, \$4.95, and it is yours. Only one watch to each customer at this price. Mention in your letter whether you want Oents or Ladies Size and order to-day as we will send out samples at this reduced price for 60 days only.

R. E. CHALMERS & CO. 352-356 Dearborn St. Chicago.

## EARN A BICYCLE

BY SELLING BAKER'S TEAS, ETC., among your friends. A total of \$800.00 to \$100.00 worth for a Bicycle. Watches, Furniture, Crochery, Cameras for smaller sales. Express prepaid. Write for catalogue, order-sheet, etc. W. G. BAKER (Department 87), Springfield, Mass.

## \$8333 MONTHLY SALARY

PAYABLE WEEKLY with EXPENSES Men or Women to represent us in their own state. Your duties to take charge of solicitors and attend to collections. No investment required. Send stamp for application blank. CO-OPERATIVE CO., 305 Star Bldg., Chicago, Ill.

## BEST CALICO 3/8c. Yard

gingham, 3/8c.; seamless socks, 3/8c.; blueing, 1c.; soap, 1c.; stove-polish, 2c.; gold ring, 1c.; jeans, yard, 9/16c.; spectacles, 3c.; men's jeans pants, 49c.; boy's pants, 46c.; man's \$2.50 shoes, 99c.; men's shirts, 15c.; dippers, 2c.; knives, 3c.; shoe-blacking, 1c.; men's wool socks, 9/16c.; box tacks, 1c.; men's fine suits, \$3.98; rice, per pound, 3c.; oatmeal, 2 1/2c.; smoking-tobacco, 3/8c. Send for price-list. C. A. WILLARD CO., Chicago, Illinois.

### IN TEXAS, WHERE MY HEART IS

BY WILL ALLEN DROMGOOLE

In Texas, when the April winds  
Are gently, softly sighing,  
And running brooks, and nesting birds,  
And all the world goes wooing,  
I know how fair the prairies lie,  
Outvying all that art is;  
I know how blue her bending sky,  
In Texas, where my heart is.

In Texas, when the summer sun  
Sets all the world a-nodding,  
And listless plowmen through the deeps  
Of cotton-fields are plodding,  
I know how sweet the perfumed winds,  
With wild rose and purple clover down,  
In Texas, where my heart is.

In Texas, when the autumn winds  
Croon low and sad and tender,  
And radiant Nature scorns the best  
That human heart could lend her,  
I know the ruby kiss of Death,  
I know how keen his dart is,  
To find the summer's golden throat,  
In Texas, where my heart is.

In winter, when the scarlet skies  
Bend down to kiss the prairie,  
And list'ning noon to list'ning night  
Laughs low at Love's vagary,  
I know how wintery bleak the world  
To two who walk apart is,  
For I am here, and you are there,  
In Texas, where my heart is.

### SONS TO BE PROUD OF

Many of the greatest careers have been made by young men, says the Baltimore "Sun." Washington was but forty-three when he was called to the command of the American Revolutionary army.

Henry Clay was Speaker of the House of Representatives at thirty-four.

Stephen A. Douglas was but thirty-nine when he first became a candidate for the presidency.

John Jay was chief justice of the United States at forty-five.

James G. Blaine was only thirty-nine when he became Speaker of the House of Representatives.

Alexander Hamilton took charge of the treasury at thirty-two years of age.

Martin Van Buren at thirty-six organized the famous Albany regency, and was governor of New York at forty.

John C. Calhoun in his forty-second year was vice-president of the United States.

John C. Breckinridge, of Kentucky, was vice-president at thirty-two, and a candidate for the presidency at thirty-five.

George B. McClellan was only thirty-eight when nominated for the presidency. In military life especially young men have been most conspicuous.

General Grant was but forty when he began winning a name for himself in our Civil War, and was only forty-three when the war closed.

Napoleon was master of France and Europe before his thirtieth birthday.

Alexander the Great had conquered the world and left it before he was thirty years old.

Fremont, the Pathfinder, had explored the Rocky mountains before he was thirty years old, and was a candidate for the presidency at forty-three years of age.

Columbus was in the thirties when he explained his ideas of the Western passage and enlisted the Spanish sovereigns in the project that led to the discovery of America.

Richard Cobden was but thirty-four when he founded the Anti-Corn law league, which revolutionized the commercial policy of Great Britain.

William Pitt, ranked by some historians as the greatest of modern British premiers, was practically ruler of England at twenty-four.

### SIERRA LEONE

Sierra Leone has a memorable history. Through more than two centuries the haunt of slave-dealers and pirates, who followed the example set by Captain John Hawkins in 1562, it was the site chosen for the first practical attempt to make some reparation for the grievous wrongs previously done to West African natives. In 1787, at the instigation of Granville Sharp and other philanthropists, the British government sent to it a cargo of about four hundred liberated blacks then wandering about in London, with about eighty white women of loose character to keep them company; and on a plot of land bought from the native chiefs Freetown was started as the basis of a free community of colored British subjects. This early settlement, added to and replenished by other consignments, was none too prosperous. The new-comers quarreled with one another and with their neighbors. They were turbulent and indolent, sickly and short-lived. Matters improved when the enterprise was taken over by a Sierra Leone company in 1791, but it was only saved from ruin by the self-sacrificing energy of Zachary Macaulay, the historian's father, who was governor of the struggling colony from 1793 to 1799.

In these and later years, in spite of an appalling death-rate, the population was steadily increased by fresh supplies from the West Indies and elsewhere, and it grew more rapidly after 1807, when England's share in the slave trade was abolished by act of Parliament, and when Sierra Leone, again placed under the direct rule of the crown, came to be the principal asylum for captives rescued from illicit slavers, as well as for runaways from the interior. According to the census of 1891 it then contained over 36,000 liberated Africans and their descendants, besides—in so much of the territory as was under any sort of settled rule—more than 40,000 other black people, and 224 whites.—Fortnightly Review.

# THE ESTEY ORGAN WEARS LIKE TIME

We have prepared and issued a very handsome illustrated catalogue as a souvenir of the completion of the THREE HUNDRED THOUSANDTH ESTEY ORGAN. Among other things it shows pictures of the modest first home of the ESTEY and succeeding homes up to the present complete factory. It shows the picture of the first ESTEY organ made, and the picture of the man who made it. It tells somewhat of the early struggles and efforts to build an organ that would endure and enrich the name of the maker. It gives pictures and detailed descriptions of the newest ESTEYS and dwells lovingly upon the well known tone, quality and durability. It will not only please you but it may prevent your making a serious mistake if you contemplate the purchase of an organ. Send for it. Address

**ESTEY ORGAN CO., Madison St., Brattleboro, Vt.**

## Watch and Chain FOR ONE DAY'S WORK.

We send this Nickel-Plated Watch, also a Chain and Charm to Boys and Girls for selling 1 1/2 dozen packages of BLUINE at 10c. each. Send your full address by return mail and we will forward the Blaine, postpaid, and a large Premium List.

No money required. We send the Blaine at our own risk. You go among your neighbors and sell it. Send us the money that you get for it and we send you the Watch, Chain and Charm, prepaid.

This is an American Watch, Nickel-Plated Case, Open Face, Heavy Bevelled Crystal. It is Guaranteed to Keep Accurate Time, and with Proper Care should last ten years.

BLUINE CO., Box 392 CONCORD JUNCTION, MASS.  
The Old Reliable firm who sell honest goods and give Valuable Premiums.

## Artistic Monuments

COST NO MORE in White Bronze THAN PLAIN ONES

Marble is entirely out of date. Granite soon gets moss-grown, discolored, requires constant expense and care, and eventually crumbles back to Mother Earth. Besides, it is very expensive. White Bronze is strictly everlasting. It cannot crumble with the action of frost. Moss growth is an impossibility. It is more artistic than any stone. Then why not investigate it? It has been adopted for nearly one hundred public monuments. We have designs from \$4.00 to \$4,000.00. Write at once for free designs and information. It puts you under no obligations. We deal direct and deliver everywhere.

The Monumental Bronze Co., 847 HOWARD AVENUE, BRIDGEPORT, CONN.

## ALL THE STYLE! WE TRUST AGENTS

CYRENO BEAUTY. Shirt Waist Pins.

with 8 sets, 3 Pins in a set, different colors, to match all shades of cloth; sell to your friends for 15 cents a set and get free your choice of Three Beautiful and Costly SOLID GOLD-LAID RINGS, set with large Opal, Twin Garnet or Simulation Diamond. Send name. No money wanted unless Pins are sold.

GLOBE GEM CO., Providence, R. I.

## A FARMING GROUP "The Balloon"

PAINTED BY JULIEN DUPRES

A Most Beautiful Picture for the Home

This Masterpiece represents a family of peasants in the harvest-field. It is noonday—not a breath of air is stirring, and away off in the distance, where the villagers are holding their country fair, a halloon hangs in the sky. They gaze in mute astonishment, wonder, awe and admiration revealed in their faces and attitudes. It is the work of a master hand.

This is reproduced in colors, 22x30 inches, in a marvelous oil-painting effect. You could not buy one for \$2.00. We bought them in ten thousand lots, so can offer it mailed in a tube, post-paid, with a three months' subscription to THE WEEKLY BEE For 25c.

Address THE BEE PUBLISHING CO., 1759 Farnam Street, OMAHA, NEB.

## 144 PIECE FREE DINNER SET

Full size for family use, beautifully decorated & most artistic design. A rare chance. You can get this handsome dinner set and one dozen fine plated tea spoons for selling our Pills. We mean what we say & will give this beautiful dinner set absolutely free if you comply with the extraordinary offer we send to every person taking advantage of this advertisement. To quickly introduce our Vegetable Pills, a sure cure for constipation, indigestion & torpid liver, if you agree to sell only six boxes of Pills at 25 cts. a box write to-day and we send Pills by mail, when sold send us the money & we send you one dozen plated tea spoons together with our offer of a 144 piece dinner set same day money is received. This is a liberal inducement to every lady in the land & all who received the spoons & dinner set for selling our Pills are delighted.

AMERICAN MEDICINE COMPANY, DEPT. O, 32 WEST 13th STREET, NEW YORK CITY.

## EVERY WOMAN

Can buy a WORLD'S WASHER on trial and no money paid until it is perfectly satisfactory. Washes easy. Clothes clean, sweet and white as snow. Child can use it. I pay freight. Circulars free. C. E. ROSS, 110 Clean St., Lincoln, Ill.

## THE ELECTRICITY

from the batteries will turn a needle through your table or hand. Cures Rheumatism, Liver and Kidney disease, weak and lame back, etc. For advertising purposes we will give ONE BELT FREE to one person in each locality. Address E. J. SNEAD & CO., Dept. No. 369, Vineland, N. J.

## WIRE STRETCHERS

8 to 15; 90c. to \$3.45 per 100. WEAVER \$1.00. Charges paid. Circulars free. Agents wanted. FULTON SUPPLY CO., Box 1, Wauseon, Ohio.

## \$2.75 buys a MAPLE AND BABY CARRIAGE

Buy a Beauty complete with rubber tire, wheels and padding. Full line of Sleeping Coaches and Go-Carts. 49 page Catalogue Free. Address Dept. 11 VICTOR MANFAC. CO. 161 to 167 Plymouth Place, CHICAGO, ILLINOIS.

# TRIUMPHS OVER DISEASE

## THE PSYCHIC SCIENCE AS PRACTICED BY DR. PEBBLES ASTONISHES THE WORLD

DR. PEBBLES, noted the world over as a physician and scientist, is astonishing the world by his wonderful cures. Diseases which have baffled all former treatments he permanently cures. His patients not only receive his Psychic and magnetic treatments, but also mild, vitalized remedies. Magnetic treatment alone has failed to cure thousands when if it had been combined with proper vitalized remedies a cure would have resulted.

THE PSYCHIC SCIENCE is the science of the mind. Psychology and mesmerism are merely stepping-stones to this occult science. To the searching eye of the psychic physician the human body is an open book. Disease has no secrets he cannot fathom. What is your condition? Dr. Pebbles can tell you. His diagnoses are marvelously correct. Write at once, giving full name, age, sex and leading symptom in own handwriting and receive free of charge a full diagnosis of your case; also an essay on the Psychic Science in the cure of disease. Address DR. J. M. PEBBLES, 539 Packard Street, Battle Creek, Michigan.





OUR SUNDAY AFTERNOON

RECIPE FOR HAPPY LIVING

Three ounces are necessary; first of patience, Then of repose and peace; of conscience A pound entire is needful; Of pastimes of all sorts, too, Should be gathered as much as the hand can hold; Of pleasant memory and of hope three good drams There must be at least. But they should moistened be With a liquor made from true pleasures which rejoice the heart; Then of Love's magic drops a few— But use them sparingly, for they may bring a flame Which naught but tears can drown. Grind the whole, and mix therewith of merriment an ounce To even. Yet all this may not bring happiness Except in your orisons you lift your voice To Him who holds the gift of health.

CHOOSING A WORK

Many a young man fails to make his mark in the world because he does not make a choice of occupation. This is a very commonplace remark, and so also is the inquiry why is a choice not made. The painful fact is that the young men who think and consult about the future, and come to some well-defined plan of life, are in the minority, while the men who take things as they come, care little for the future, and plan less for it, are in the majority. But there are a large number of men who are in perplexity about the future. They almost wish some overwhelming circumstances would force them into an occupation or a profession. Men are endowed with the power of choice, and we must decide for ourselves.

True, a man's choice will be modified by circumstances not in his immediate control, but, after all, one must act for himself. The power of choice does not, of course, prevent the asking for that wisdom from above, which will be liberally given to those who devoutly seek it. Recently an able and prominent man was in great perplexity as to his duty concerning the acceptance of a call which would involve giving up a field in which there was promise of large usefulness. The pressure from both sides was strong, and he was in much anxiety as to what was his duty. In announcing his decision he stated that he reached his conclusion upon the principle that "the largest opportunity to do what we can do best surely constitutes as divine a call as can be discerned by human judgment and conscience."

There is much in this short but inclusive statement. It will bear close examination, is worthy of careful thought, and is good enough to be made a rule of action. The first inquiry is, What can I do? I may be able to do several things, and do them reasonably well, but there must be a selection, and hence the second inquiry, What can I do best? Then follows the question of opportunity, Where and how can one find not only opportunity, but the largest opportunity to do what one can do best? The man who finds "the largest opportunity to do what he can do best" has chosen his work, the method and the field.—Young Men's Era.

THE POETRY OF COMMON LIFE

A farmer in Illinois has painted the picture of a corn-field that is to be shown at the Paris Exposition this year. In painting this picture the farmer artist has accepted the challenge of James Whitecomb Riley, who, in his ballad "When the frost is on the pumpkin, and the fodder's in the shock," says that the farm presents a picture that "no painter has the colorin' to mock." Mr. Montgomery once called the attention of the Hoosier poet to this challenge, and he announced that he would accept it. He claims that he has taken no lessons except from Nature. He has painted during the last thirty years hundreds of farm scenes. It is claimed that so realistic are some of the ears of corn seen in the pictures that they have at different times attracted the nibble of a horse and the peck of a hen. It is always beautiful to see any man who appreciates the poetry in the common work which he does to earn his bread. There is no life so hard and grimy but it has in it some poetic beauty which a happy heart and cheerful spirit can discover.—Selected.

LIFTING ROCKS FOR THE WEAK

The honey-bird is a well-known denizen of many parts of the Transvaal. It has the unique peculiarity that it does not fear men or women, but actually flies up to them, uttering a plaintive low note, and flying about their heads, tries to lead them on to the nearest clump of rocks. The bird knows full well that under a certain rock lies a store of honey, concealed by the cunning bees, and the clever little fellow tries to induce a friendly being with two strong hands to push aside the rock, so that it may get to the honey. If it succeeds in its object the bird changes its plaintive tone to one of joy and pleasure, as much as to say, "Thank you very much." If we go on our way vigilant we shall see many an opportunity to turn aside the heavy rocks that hide the sweetest honey from those who are too weak to secure it unaided. What a happy fate it is to be able to use our strength in thus giving joy to the weak.—Current Anecdotes.

CAN WE KNOW WHAT JESUS WOULD DO?

CERTAINLY no one could have foretold, when our Lord was on earth, just what he would do under any conceivable set of circumstances. His acts were original and surprising, and constantly puzzled both his friends and his foes. He baffled natural expectations as to what he would do. But he himself knew what he would do. It was because he was more than a man, and on more than a human errand among men. The human cannot foretell what the divine is going to do the next hour. This raises the question whether any one of the sons of men to-day is perfectly sure what Jesus would do were he here to-day and in our circumstances.

But there were large tracts of conduct into which he positively refused to enter, and singularly enough these are the very ones into which some are ready to rush to-day, forgetting the familiar proverb about what angels fear to try. There are questions in the social life, in the burning problems of capital and labor, of wealth and poverty, of men's rights and women's rights. On all such matters he was silent, except as he laid down permanent principles that we may apply to everything. Did he, in fact, say anything about human rights? Was not his emphasis always upon duties? One comes and asks him to settle a dispute about a will; but just where we should have been glad to have him say an illuminating word he refused to say anything, "Man, who made me a judge or a ruler over you?" But, turning to the people, he read them a lesson against covetousness, which was at the root of the question about the inheritance. He gave a principle, and left the application to be worked out by those who heard him. The modern demagogue, who parades under the name of the Christian religion of an extra superbraud, tries to array the rich and the poor into two antagonistic classes; but Jesus never fed the class spirit. He never championed the poor simply as being poor, although he was a poor man himself. He spoke with solemn severity to the rich about the peril they stood in, but he sat at meat with them; he took Matthew from the seat of custom, and Zaccheus from his exhortations, both of them representing the capitalist class.

The familiar question, What would Jesus do? is more difficult to answer because he came into the world with a most definite work to perform, in which we can imitate him only in spirit. His "Lo! I come to do thy will, O God," should be our motto; but no two souls are appointed to the same tasks. He was not only the perfect man, but the Redeemer of the world, and as such had a work to do in which we cannot copy him. We must bear our own, but not his cross. Christ gives us not a program, but a law of the Spirit of Life. Jesus laid down principles, but left few rules. He bade us follow him, learn of him, bear the cross after him, and be in the world as he was in the world; but all this was in the region of motives, principles, and the tone and spirit of the life. The man says to him, "Make my brother divide!" He wanted a program. Jesus said, "Beware of covetousness!" There was a principle. Whether we are bank presidents, or mill-owners, or hands in the factory, or sewing-girls; whether we are sick or well, bond or free, we may have the mind of Christ. I shall know what I ought to do, whether or no I can say exactly and to the world what he would do. "He that followeth me," he said, "shall not walk in darkness, but shall have the light of life."—Dr. Packard, in the Independent.

You complain of fulness, and pressure after eating; your head aches, usually in front. You are subject to the annoyance of bad breath and an unpleasant taste. Your eyes are affected by a strong light; and you are hungry even after a good meal. These things affect your temper and disposition, and you are none too sweet to those around you.

That's Dyspepsia

"For two years I suffered from dyspepsia, until for days at a time I could not eat a thing. I had tried almost everything, but could not get relief. I then thought I would try Ayer's Sarsaparilla, and in one week I was a new man. My tired feelings were gone; I was stronger and better in every way. I believe now if it were not for this medicine I would be in a dying condition."—JOHN MACDONALD, Philadelphia, Pa., Aug. 16, 1899.

A Sarsaparilla made of chemically pure drugs, thoroughly examined, scientifically exhausted, and prepared with the utmost care.

That's AYER'S

Manufactured under the personal supervision of a graduate in pharmacy, a graduate in chemistry, and a graduate in medicine.

Your muscles are flabby and flat. Your shoulders stoop. You are weak, listless, and tired. You are too cold or too warm; short of breath. You are like an engine that needs more fuel. You are one day sick and one day well; yet one day's good work brings three days' weariness. You feel old at thirty and ready to drop.

That's Starved Blood

"Last spring I could not walk, my feet were so swollen. I was emaciated and my blood was like water, it was so colorless and thin. Eight doctors tried to cure me, but they did me no good. A counsel of doctors said that I could not possibly live. Then I thought I would try Ayer's Sarsaparilla, as I had read so much about it. I took three bottles, and now I am perfectly well and weigh over 150 lbs."—Mrs. M. E. SLATER, Pulasaki, N. Y., July 13, 1899.

**\$20,000 FOR A GUESS**  
ON THE CENSUS.  
**1,526 CASH PRIZES**  
RANGING FROM  
**\$3,500 TO \$5**  
Will be distributed to those guessing the nearest to the total population of the United States according to the census of 1900, as verified by the Director of the Census. Contest now going on. Call at office or write for particulars.  
*Renaud Drug Company.*  
K 161-163 STATE STREET, CHICAGO, ILL.

**WATCH AND CHAIN FREE**  
For a Few Hours' Work. We give this Silver Nickel-plated Watch, also a Chain and Charm, to boys and girls for selling 1 1/2 dozen packages of "DOVENSIRE," the Sachet Wonder, a fad throughout England. Finest Imported English Sachet Perfume. Sells on sight. No money required. Send your full address and we will forward the Perfume post-paid, also a large Premium Catalogue. You sell it among your neighbors at 10c each, send us the money and we send you this Watch or any other premium you select. Cash commission if preferred. If you write TO-DAY we will send you a beautiful jeweled Scarf or Stick Pin absolutely free in addition.  
STANDARD IMPORTING CO., Dept. A. 28 ST. LOUIS, MO.  
This firm is well known for its honest goods and premiums.

**MISSOURI PACIFIC RAILWAY** and **IRON MOUNTAIN ROUTE**  
**Low Rate Excursions to the West and Southwest...**  
TICKETS ON SALE  
**APRIL 3d and 17th**  
For Further Information, Folders, Land Pamphlets, Maps, Etc., address any agent of the company, or  
**H. C. TOWNSEND**  
General Passenger and Ticket Agent  
St. Louis, Mo.

Ladies' or Gents' size **FREE** WATCHES, RINGS, WATCH-CHAINS AND CHARMS, &c. As a grand premium, any one can earn this Beautiful Gold Plated Hunting Case Stem Winder Watch, Charm and Chain, a perfect time-keeper, by selling our **ELECTRIC LAMP WICKS**. They can be sold in a few hours. They are practically indestructible. No trimming; no smoke; no smell.  
**OUR SPECIAL 90-DAY OFFER**, which is apart from the above: Send us your name and address (no money); we will send you 20 wicks, postpaid; sell them at 5cts. each and remit us \$1, and we will mail to your address, *free*, a Beautiful Gold Plated WATCH-CHAIN AND CHARM, also a Handsome Gold Finished Ring.  
**ELECTRICAL WICK CO.,**  
Dept. T, Orange, N. J.

**LEARN TELEGRAPHY** For Railroad and Commercial Service. Typewriting Course FREE. Paying positions guaranteed. Catalogue Free.  
**FISSK TELEGRAPH SCHOOL, LEBANON, PA.**

**AID FOR THE DEAF**  
Sent on Trial, absolutely FREE of expense or risk. Address  
**P. G. TIEMANN & CO., 107 Park Row, New York.**





HE LIKED AUCTIONS

Mister Peterson he tended all the auction-sales That came off For miles around. He used to get his back up, and he'd swow he wouldn't go, But the bills would always tease him, and the first thing he would know, When there was a hoop-ti-doo In the shape of a vendue, There Mr. Ezry Peterson was regularly found. He bought up patent winnowers that somehow wouldn't sift, He had a dozen spinning-wheels—for every one a "swift," He had a lot of ox-yokes, though he never owned an ox, And more'n a thousand rusty keys that wouldn't fit the locks. He never had the moral strength to leave a thing 'twas cheap, And oh, the stuff he carted off—you should have seen the heap! But when he'd haul the mixture home and dump it in the yard, Mis' Peterson would hustle out and give it to him hard. And though he'd promise better things, his grit would always fail, And, thunderation, off he'd dodge and 'tend another sale. Pod-augers and patent rights, Old fuseses with busted sights, Tin lanterns and wooden flails— He jest went loony at auction-sales.

Mister Peterson he tended all the auctions round. Had to go Or he would bust. He knew he hadn't ought to, but you see he was afraid That possibly it might occur he'd miss a mighty trade. And so at each vendue He was there, and bidding, too, A-startin' ev'ry figger just as though he thought he must. The time they thought Mis' Peterson was surely goin' to die The Pottses store was auctioned off, and Ezry made a try To stay at home and mind his biz, but when he heard the bell He hustled down as quick's he could—and though it's hard to tell— They had a coffin for sale; the thing was built and planned For some one that it failed to fit—and so 'twas second-hand. Now Ezry saw he had a chance to save a little tin, And up he braced, as big's you please, and bid that coffin in. But when they told Mis' Peterson, she r'ared and tore, oh, my! And got so mad right through and through, by gosh, she didn't die. Pod-augers and patent rights, Old fuseses with busted sights, Broken tools and old machines— And he uses that coffin for storin' beans. —Lewiston Journal.

THE COURT COMMITTED ITSELF

THE prisoner was making his appearance before the magistrate for the hundredth time. "Well," said the magistrate, "you here again?" "Yes, your honor," responded the prisoner. "What is the charge?" "Vagrancy—same as before, your honor." "It seems to me you are here about half your time." "Yes, about that, your honor." "Well, what do you do it for? Why don't you work?" "I do, your honor, more than half my time." "Ah, now," said the magistrate, surprised, "if you can tell me where you have ever worked I'll let you off." "In prison, your honor," answered the prisoner, brazenly; and the judge kept his word.—Collier's Weekly.

THE PREACHER'S REBUKE

The preacher came to dine with the mean man, who, though wealthy, set but a spare table. "I've nuthin' to offer you, parson, but bacon an' greens," said the mean man; "will you ax a blessing on 'em?" "Lord, make us thankful," said the preacher, "for what we are about to receive. We expected nothing but greens, but here is bacon also. Make us truly thankful."—Sunny South.

NOT THAT TIME

"Woman is always at the bottom of man's troubles," he sighed. "Oh, I don't know," his wife answered. "When mama poured that water on you from the second-story window while you and your jag were reclining on the front steps the other night it wasn't the woman who was at the bottom."

LINGUISTIC GEOGRAPHY

"Hello!" called a high-pitched voice through the telephone. "Is this Twiggins and Haggerty, in the back-of-the-yards district?" "Yes." "This is Mr. Fox, of Kenworth. Is either of the firm in?" "Come again!" "I say, is either member of the firm in?" "Either—either!" "Can't you understand?" "Don't catch it. Say it again." The soft voice of the telephone girl at the central station broke in. "Try 'eether,'" she suggested. "Perhaps they don't say 'eyether' back of the yards."—Chicago Tribune.

HE WAS WELL FED

A little East Side boy was being prepared for bed a few evenings ago when he saw the "goose-flesh" on his little limbs; he suddenly looked up and asked, "Mama, what are these funny spots on me?" His mama told him she "didn't know." "Oh," said the little one, "I know; it's some of my food sticking out."

A BETTER GRAFT

Weary Wraggs—"When a lady gives me a meal I allus say, 'May your shadow never grow less.'" Frayed Feeter—"When a lady gives me a meal I allus say, 'May your photographs allus need as little touching up as dey do at present,' and git a quarter in addition!"—Puck.

A POSTPONEMENT NECESSARY

"Dar won't be any baptizin' dis maw'nin'," said the colored deacon. "Br'er Williams is dez come fum de millpon', en his word is dat five hongry-lookin' alligators is out sunnin' deyse'f, en my 'speunce is dat dey's no respec'er er pussions!"—Atlanta Constitution.

IN THOROUGH SUBJECTION

Mr. Meeker, who had gone to the front door to answer the postman's ring, put his head inside the door of the room where his wife was sitting. "It's a letter for me, my dear," said he. "Shall I open it?"—Chicago Tribune.

TWINKLE, TWINKLE, LITTLE STAR

Scintillate, scintillate, globulè vivific, Wonderingly contemplated by men scientific; Elevated and poised in the ether capacious, Resembling a coruscant gem carbonaceous. —Boston Version.

WISE PHILOSOPHY

Perkins was bewailing his misfortunes, dwelling on them, moping over them. "My dear fellow," said Wyndham, "we all have to go through these thorny patches in life, but we needn't sit down in them."

HER NATURAL RIGHTS

Mama—"I don't see where you get your red hair; you don't get it from your papa, and you certainly don't get it from me." Little Dorothy—"Well, mama, can't I start something?"—Puck.

WITHOUT

Liveried menial—"Me lud, the carriage waits without." Lord Fitz Josher—"Without what?" Liveried menial—"Without horses, me lud; 'tis an automobile."—Chicago Record.

A LEFT-OVER JOKE

"What is the difference between Dewey and a floor-walker?" "One sails about the seas and the other sees about the sales."—Judge.

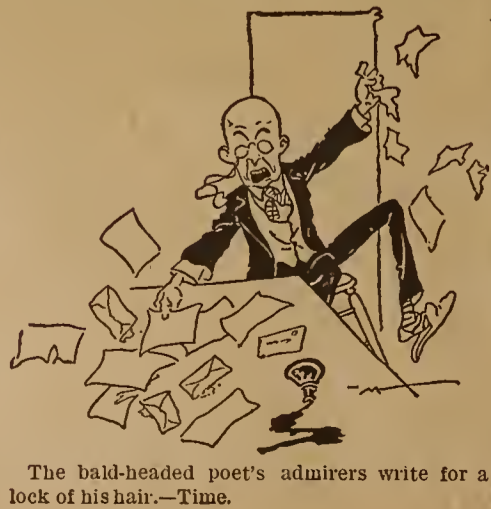

The bald-headed poet's admirers write for a lock of his hair.—Time.

"Housework is hard work without Gold Dust"

Washing Willow Furniture and Wicker Chairs Wicker chairs soon become soiled, but they can be cleaned to look like new with Gold Dust Washing Powder and warm water. Use a scrubbing brush; when water becomes the least soiled, get fresh; follow with a soft, dry cheese cloth, and wipe dry. White iron beds can also be washed by this method, but must be wiped dry quickly. The above is taken from our free booklet "GOLDEN RULES FOR HOUSEWORK" Sent free on request to THE N. K. FAIRBANK COMPANY, Chicago, St. Louis, New York, Boston.



AN ACRE OF CORN and its possibilities under the Silage system—being the theme of "A BOOK ON SILAGE" By Prof. F. W. WOLL, of the University of Wisconsin, neatly bound into a volume of 195 pages and now being sent out by the SILVER MFG. CO., SALEM, O., is unquestionably the best book yet introduced on the subject. It includes: I—Silage Crops. II—Silos. III—Silage. IV—Feeding of Silage. V—Comparison of Silage and other Feeds. VI—The Silo in Modern Agriculture, and many valuable tables and compounded rations for feeding stock. They are going rapidly. To avoid disinterested inquiries the Price is 10c. coin or stamps. SILVER MFG. CO., Salem, Ohio.

WALL PAPER can be effective without being high-priced. Our 29 years' experience and improved machinery enable us to make the best effects for lowest cost. See our samples before placing your order. Agents wanted everywhere. KAYSER & ALLMAN, 1214-16 Market St., Philadelphia.

DEALERS PRICES CUT IN TWO Musical Instruments of all Kinds fine toned and of beautiful construction, workmanship and finish. Shipped direct from factory at wholesale prices C. O. D. with privilege of examination. We have the best for the least money. A sweet toned Mandolin, finely finished in mahogany and maple, 9 ribs, \$4.00, dealers ask \$8.00; high grade Guitar \$2.90, worth \$3.00; Stradivarius Model Violin, case and full outfit, \$5.15 equal to any sold at \$8.50; Banjos \$1.25 and up; Graphophones \$5 and up. PIANOS AND ORGANS sent on 30 days FREE TRIAL. A \$350 high grade Kenwood Piano \$155. A \$75 Organ \$32.50. Pianos as low as \$120. Organs down to \$21.75. All instruments guaranteed. Send for large illustrated Catalogue FREE. Address: CASH BUYERS' UNION, 160 W. Van Buren St., B-7, Chicago.

A \$12 Bath Cabinet only \$5.00 Our new 1902 style Squire Quaker guaranteed best of all cabinets at any price. Has real door on hinges, steel frame, best materials, rubber lined, folds flat, lasts 20 years. Turkish and Vapor baths at home \$8 each. Open the millions of pores, sweats poison out of the blood, keeps you clean and healthy, beautifies complexion. Physicians recommend it for Colds, LaGrippe, Rheumatism, Neuralgia, Obesity, Female Ills, all Blood, Skin, Nerve or Kidney troubles. Money refunded after 30 days use, if not represented. Price with heater, directions, formulas, \$5.00. Face Steamer \$1.00 extra. Order today. Write us. Valuable Book FREE. Agents Wanted. Big Wages. Splendid Seller. World Mfg. Co., 37 World Bld'g, Cincinnati, O.

IT TURNS TO STONE! A Fence Post, costing but a trifle more than Cedar, and lasting HALF A CENTURY OR LONGER. Adapted for ALL Fences. Write for Descriptive Circular. DURABLE CEMENT POST COMPANY, Battle Creek, Michigan.

\$1,000 SALARY PER YEAR! Ladies or Gentlemen We have shared the general prosperity of the country, and we now need one or two permanent representatives in each state to look after our interests, manage our agents, and attend to collections. This position involves no canvassing and is a bona fide weekly salaried position, with all expenses paid, to the right party. It is mainly office work conducted at your own home, with an occasional trip out among the agents. No investment required. Also three esalaried vacancies in the traveling department. Enclose references and self-addressed stamped envelope to PROVIDENCE CO., 620 Caxton Bldg., CHICAGO.

You Dye in 30 minutes Solved and faded carpets, dresses and clothing of all kinds to look like new. No experience necessary to get beautiful colors that won't fade. Boil or Wash Out with FRENCH DYE. Each package colors from one to four pounds according to shade. To introduce them give name of your dealer and we will send you 6 packages for 40c or 12 for 10c. Say whether for wool or cotton. Address FRENCH DYE CO., Box 464, YASSAR, MICH.

SENT FREE Solid GOLD or SILVER plated Bracelet sent free to any one for selling 5 sets of our LADIES' GOLD plated Dress Pins for 25c. a set; (each pin set with an exquisite jewel.) Simply send your name & address & pins postpaid. When sold, send us the money & we will send you the Bracelet. The chain is beautifully engraved & the lock opens with a dainty little key. We trust you & will take back all the pins you cannot sell. Write to-day. THE MAXWELL CO., Dept. 555, St. Louis, Mo.

SHIPPED ON APPROVAL and trial to any address before you pay a cent 1900 MODELS, best makes, \$11 to \$20 '99 & '98 MODELS, high grade, \$8 to \$13 600 Shopworn and Second Hand Wheels, \$3, \$5, \$8 and \$10. Great Factory Clearing Sale. Write for Art Catalogue and Bargain List. MAKE MONEY fast and easy as our representative in your town. First applicants may obtain FREE USE of sample wheel to introduce them, or can EARN A BICYCLE distributing catalogues for us. Get our special offer and inducements to agents. MEAD CYCLE CO., Dept. 43 B, Chicago.

FREE SILVER WATCH FREE! These Watches are Solid Silver, Ladies' or Gents' size, and at retail world cost upwards of \$8. or \$10. but to introduce our Persian Perfumed Perfumery we will send you this Watch Free if you take advantage of our marvelous offer. If you want one CUT THIS OUT write to us without delay. With your letter send us your name & postoffice address and we will send you on consignment, to sell for 5 cents each, 20 cases of Persian Perfumed Perfumery and our offer. After you receive the beautiful Watch we shall expect you to show it to your friends and call their attention to this advertisement. The Watch is sent Free, by Registered Post, on your complying with our advertisement, and the marvelous offer which we send, and it is Fully Warranted. You will be more than satisfied. Address at once, PERSIAN PERFUMERY CO., 19 Warren St., New York.

\$14 IT COSTS NOTHING to try our Sewing Machines. We ship direct from factory to consumer. Save agents profits. 30 days free trial. 117,500 sold. Warranted 20 Years. All attachments free. \$40.00 Arlington for.....\$14.00 \$45.00 Arlington for.....\$16.00 \$50.00 Kenwood for.....\$21.50 Other Machines at \$8, \$9 & \$11.50 Illustrated catalogue and testimonials free. Write at once for our special freight offer. Address: CASH BUYERS' UNION, 158-164 W. Van Buren St., B-7, Chicago, ILL.

WE SHIP ON DEPOSIT \$100 \$11.75 Buys a Bicycle Complete. Unparalleled. \$16.50 Buys an Up-To-Date Model. Fully guaranteed. \$22.50 Buys a Full Racing Model. Shop-worn Bicycles from \$10 up. 2nd Hand Wheels from \$5.00 up. We want agents everywhere. 64 page catalogue of bicycle parts and repairs free. Write for catalogues and see how you can get a Bicycle free by helping us advertise. Address Dept. B43, VICTOR MANFG. CO., 161-167 Plymouth Pl., Chicago, Ill.

GUITAR, MANDOLIN, VIOLIN, BANJO, PIANO AND ORGAN Self-Taught, without Notes, by Figure Music. Big Illustrated Catalog of Self-Instructors and Instruments sent FREE. We ship the first instrument in each locality at a big discount, simply to advertise our goods and establish a trade. Address E. C. HOWE, 459 Bay State Bldg., CHICAGO

\$3 a Day Sure Send us your address and we will show you how to make \$3 a day absolutely sure; we furnish the work and teach you free; you work in the locality where you live. Send us your address and we will explain the business fully; remember we guarantee a clear profit of \$3 for every day's work, absolutely sure, write at once. ROYAL MANUFACTURING CO., Box 64, DETROIT, MICH.

10 Weeks The biggest, brightest and best Western Weekly paper in existence. Grand views of scenery, stories of adventure and full mining reports weekly. Tenth year. Solely to introduce the paper it will be sent 10 weeks on trial for 10c.; clubs of six \$5c.; 12 for \$1. Stamps taken. ILLUSTRATED WEEKLY, DENVER, COLO.

LADIES I Make Big Wages AT HOME and will gladly tell you all about my work. It's very pleasant and will easily pay \$18 weekly. This is no deception. I want no money and will gladly send full particulars to all sending 2c. stamp. MRS. A. H. WIGGINS, Box 20 Benton Harbor, Mich.

WANTED Reliable men or women to sell our goods to the consumer in communities from 1,000 to 10,000 population; permanent employment at good pay. Address THE GREAT EASTERN COFFEE & TEA CO., 301 South 10th Street, St. Louis, Mo.

1427 Silk Fringe Cards, Love, Transparent, Escort & Acquaintance Cards, New Puzzles, New Games, Premium Articles, &c. Finest Sample Book of Visiting & Hidden Name Cards, Biggest Catalogue. Send 2c. stamp for all. OHIO CARD CO., CADIZ, OHIO.

OPIUM and Liquor Habit cured in 10 to 20 days. No pain till cured. Write DR. J. L. STEPHENS CO., Dept. A3, Lebanon, Ohio. PATENT secured or money all returned. Exam. Free. COLLAMER & CO., 1040 F. St., Wash., D. C.



**"HONESTY** is the best policy." Nobody contradicts it.

Your dealer can get lamp-chimneys that almost never break from heat, or those that break continually. Which does he get? Which do you get?

Macbeth's "pearl top" and "pearl glass" are tough against heat; not one in a hundred breaks in use. The glass is clear as well as tough. They are accurate, uniform.

Be willing to pay more for chimneys that last till they rot, unless some accident happens to them.

Our "Index" describes all lamps and their proper chimneys. With it you can always order the right size and shape of chimney for any lamp. We mail it FREE to any one who writes for it.

Address MACBETH, Pittsburgh, Pa.

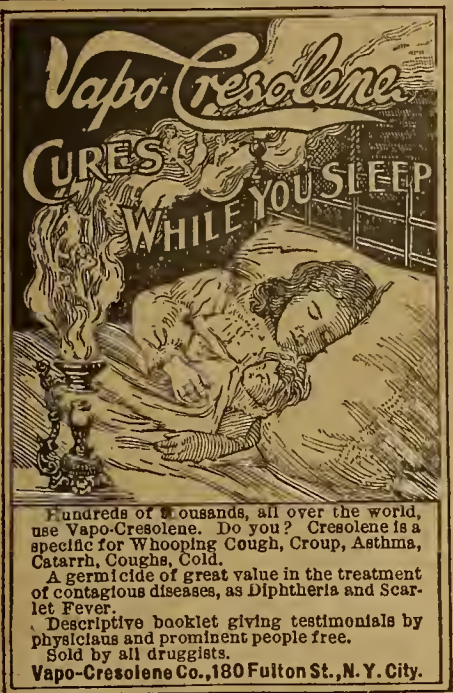

**Vapo-Cresolene**  
CURES WHILE YOU SLEEP

Hundreds of thousands, all over the world, use Vapo-Cresolene. Do you? Cresolene is a specific for Whooping Cough, Croup, Asthma, Catarrh, Coughs, Cold.

A germicide of great value in the treatment of contagious diseases, as Diphtheria and Scarlet Fever.

Descriptive booklet giving testimonials by physicians and prominent people free. Sold by all druggists.

Vapo-Cresolene Co., 180 Fulton St., N. Y. City.



This Neat Little Garment is a Combined

**Bust and Skirt Supporter**

It comes quite to the waist line, is self adjusting and fits beautifully. In ordering give bust and waist measure. Price in drab, white, black or netting, \$1.00 postpaid.

We Want Agents for this fast selling Waist, and to any lady who sends us, with her order, the name and address of one good agent, we will allow a reduction of 30 cts. in the price, making the cost 70 cts. instead of \$1.00.

**The Crescent Works,** Manufacturers of High Grade Custom Corsets, Waists and Skirts.  
21 Main Street, Ann Arbor, Mich.  
General Agents Wanted.

**BE A BEE KEEPER.**

Fascinating and profitable occupation. Our Semi-Monthly Magazine.

**GLEANINGS IN BEE CULTURE**

tells all about it, so that beginners understand how to handle bees and make money. Sample copy and books on Bee Culture and catalogue of all Bee Supplies free if you mention this paper. We are the leading manufacturers of everything for bee keepers.

THE A. I. ROOT COMPANY, MEDINA, OHIO.



**KEEP YOUR FEET COOL**

Can be attached to any shoe, New or Old. Price 50 cents per pair. Easily attached by any shoe-maker. Write for circular, or inquire of your shoe-dealer.

H. H. TROXEL & CO., ELYRIA, OHIO.

**DR. F. WILHOFT'S (ORIGINAL) LADY'S SYRINGE.**

THE ONLY PERFECT VAGINAL SYRINGE. Its principle of action—that of INJECTION and SUCTION—assures a thorough cleansing. ALL in one piece of best soft rubber; always ready for instant use. Our illustrated booklet, "Useful Information for Women," free. DR. F. WILHOFT, 555 Mott Ave., New York.

We Will Make You a **SUIT or OVERCOAT** for \$6.50

If you have any goods on hand to be made into suits or overcoats, we will cut, make, and furnish all linings, silk, buttons, etc., for the above price. FIT and WORKMANSHIP guaranteed. Self-measurement blanks, fashion plate of latest styles, etc., furnished upon request. Write us for further information.

THE COLUMBIA TAILORING CO.  
Dept. 5, 133-137 W. Madison St., Chicago, Ill.

**BABY CARRIAGES** Shipped C.O.D. to anyone. Direct from factory at lowest wholesale prices. Dealers large profits saved. No money in advance. \$15 Carriage, \$9.00 | \$5.00 Carriage, \$3.00 | \$3.00 up. Send for free illustrated catalog and special offer CASH BUYERS' UNION, 164 West Van Buren St., Chicago, Ill.

**How to Dye** A new 32 PAGE BOOK giving latest and Best Methods for Home Dyeing. It saves time, money and bother. Sent FREE. CUSHING & CO., FOXCROFT, MAINE.

**HOUSEHOLD**

[CONTINUED FROM PAGE 13]

**THE INCAPABLE**

"In God's own image"—on the world's highway  
He stands—incapable; a human drone,  
Where only shadows of great actions play,  
Too feeble-hearted to demand his own.  
God lent him strength of muscle and of mind,  
The power to do a man's work, and to tear  
The chains away from poverty and bind  
The coward unbelief within its lair,  
And yet he stands—a loafer, while the throng  
Of helpful, busy workers pass him by;  
He hears the happy note of labor's song,  
His only answer is a sullen sigh;  
Who was it took the sand from out his will—  
The strong, hard sand, and put soft putty there?  
Who bred the laziness that could but kill  
The courage that should frame the brave "I dare!"

His parents—they who thought to buy with gold  
What God has said can only come through work  
And self-denial—for the world can hold  
No honest habitation for the shirk.  
Poor, useless loafer on the world's highway,  
As youth goes crowding past you, stand and tell  
How foolish love turned God's work into play;  
They made your path too soft—incapable!  
—Rural New-Yorker.

**BABY'S NEEDS**

FOR a baby who is unable to walk, but can sit alone, a swing-chair may be made, which is often a rest from the high-chair. I took a child's rocking-chair and sawed off the lower part, legs and rockers, then fastened strong rope through holes bored in the bottom and back, also tied to the arms. These ropes were tied to a spring on each side. The spring was doubled, and a rope from the ends fastened to a hook in the ceiling or doorway made the chair complete. Baby could swing back and forth or up and down to his heart's content, the whole cost being but forty cents. These chairs may be found in the stores at a cost of two dollars and upward, but with a little ingenuity a home-made one will satisfy the child, and at a much smaller expense.

To protect the clothes while creeping it is well to make the baby some "creepers." These can be made with the upper part like an apron or waist, large enough to cover the dress, and the lower part like drawers extending below the knees.

Accustom baby to going out every pleasant day. Even in winter there are many days when the child may be taken out in his carriage if warmly clothed. It is a mistake to keep the sunshine and air from the baby all winter, and render him more liable to colds and other illness.

Rubber toys are very desirable for first playthings. The "squeak" delights the baby, and the toys can be washed occasionally. Avoid painted toys or those which will stain the skin when wet. A child is usually more pleased with one thing at a time than with a large assortment of toys before him. A large newspaper will often amuse a baby for some time while the busy mother is about her household cares.

Of course, the baby needs some attention, and will tire at times of the most interesting amusements, but the woman who has no assistance in her work will save herself many steps and much care if she keeps her child independently busy.

JENNIE MAKEPEACE.

**SOME GOOD RECEIPTS**

**BUCKWHEAT SWEET BREAD.**—You will need two tablespoonfuls of shortening, three tablespoonfuls of sugar, one egg, one teacupful of sour milk, one half teacupful of soda, two tablespoonfuls of wheat-flour and one and one half cupfuls of buckwheat-flour. Pour into a small dripping-pan, and bake in a moderately hot oven. This should be eaten while warm with butter, and is delicious.

**BAKERS' GINGER-COOKIES.**—Cream one and one half cupfuls of molasses and one cupful of lard, add one teacupful of ginger and one teacupful of salt, then pour in one and one half cupfuls of rich sour milk into which has been dissolved one teacupful of soda; stir all together and thicken with flour. Roll out rather thick, cut with a cookie-cutter, and bake in a moderately hot oven.

**RUSKS.**—Take three cupfuls of bread-dough and mix with two thirds of a cupful of shortening, one cupful of sugar and one cupful of warm milk; add two eggs and flour enough to thicken. Put in pail, and let rise until light, then roll out two thirds of an inch thick, and cut with biscuit-cutter; let rise again until light, and bake for twenty-five minutes. M. H. BALDWIN.

**WHAT HER MOTHER-IN-LAW SAID**

TIMELY ADVICE GIVEN TO A YOUNG WIFE

If there ever is a time when a woman needs help and counsel it is in those months which follow marriage, the period of physical adjustment to the new condition of wifehood. There is something pathetic in the story told below, reflecting as it does in the main the experience of so many young wives.

"Three months after marriage," the story begins, "I became very miserable. I was so sick and nervous, but I did not know what was the matter with me."

Many a wife who reads those words will recall her own condition in those early days of marriage, when she stood in the shadow of motherhood, and found herself suffering and fearful. Womanly modesty closed her lips on the questions which vexed her mind, and away from home and family there was no one who out of her experience could give her a word of advice or counsel. Happier



was this other young wife. Her husband's mother read her condition with the eyes of experience, and better than giving advice gave her the medicine to strengthen and cure her.

**A YOUNG WIFE'S STORY**

"About ten years ago I was married, and three months later I became very miserable, but I did not know what was the matter with me," writes Mrs. John Heumis, of Munson Station, Pa. "I was so sick and nervous, was not able to do any work at all, had to hire it all done. My husband's mother had been using your remedies, and one day she came over to see me and brought some of your 'Favorite Prescription' with her, and said, 'Take that medicine—I know it will help you.' I took it and it did help me, and I got better of the bad feelings that I had before I commenced taking it; was soon able to do my work myself. I took the medicine right along till after the baby came, and I can safely say that Dr. Pierce's Favorite Prescription is better than all the other doctor's medicine put together."

If every young wife had so good a friend and wise a counselor in her husband's mother there would be less unhappiness in the world. The use of Dr. Pierce's Favorite Prescription by young wives prevents or cures those feelings of depression which are so common when maternity is anticipated. It tranquilizes the nerves, encourages the appetite, and causes the sleep to be natural and refreshing. As the body is strengthened, the mind recovers its brightness. There is no more gloomy fears of the future. The little wardrobe is prepared with the tenderest delight, and the hour of trial is approached in comfort and the perfect confidence in the favorable result.

**WONDERFUL RESULTS**

All women who have used "Favorite Prescription" in prenatal preparation testify to the wonderful and unexpected results produced by this medicine. This is especially the case with those whose past experiences in maternity have been peculiarly painful and prolonged. To have the baby's advent made practically painless; to have the time of trial reduced to a brief period where heretofore it has been prolonged into hours; these things seem almost miraculous and past belief. Yet these are the results which follow the use of Dr. Pierce's Favorite Prescription.

"When I wrote to you in March, asking advice as to what to do for myself," says Mrs. Ella Reynolds, of Guffie, McLean Co., Ky., "I was expecting to become a mother in June and was sick all of the time. Had been sick for several months. Could not get anything to stay in my stomach, not even water. Had a mishap twice in six months, threatened all the time with this one. Had female weakness for several years. My

hips, back and lower bowels hurt me all the time. Had numbness from my hips down. Had several hard cramping spells, and was not able to do any work at all. I received your answer in a few days, telling me to take Dr. Pierce's Favorite Prescription. I took three bottles, and before I had taken it a week I was better, and before I had taken it a month I was able to help do my work. On the 27th of May my baby was born, and I was only sick three hours, and had an easy time. The doctor said I got along nicely, and my husband said, 'If it had not been for Dr. Pierce we would not have had this boy.'

"We praise Dr. Pierce's medicines, for it has cured me. I am better now than I have been for thirteen years. I hope all that are afflicted will do as I have done and be cured."

**IT WILL CURE YOU, TOO**

Dr. Pierce's Favorite Prescription is essentially a woman's medicine. It is designed to cure those womanly ailments which are productive of most of woman's suffering. It reaches the most obstinate cases if its use is patiently persisted in. It is a perfect regulator. It dries the drains which sap the strength, heals inflammation and ulceration and cures female weakness. The aching back, the throbbing head, the nervousness experienced by so many women are entirely cured by "Favorite Prescription."

"I was a great sufferer for six years, and doctored all the time with a number of different physicians, but did not receive any benefit," writes Mrs. George Sogden, of 641 Bonda street, Saginaw (South), Mich. "One day as I was reading a paper I saw your advertisement, and although I had given up all hope of ever getting better, thought I would write to you. When I received your letter telling me what to do I commenced to take your medicine and follow your advice. I have taken ten bottles in all, also five vials of the 'Pleasant Pellets.' Am now regular after having missed two years and suffered with pain in the head and back. I was so nervous, could not eat or sleep. Now I can thank you for my recovery."

Women who are suffering from disease in aggravated form are invited to consult Dr. Pierce by letter, free. All correspondence is treated as strictly private and guarded as sacredly confidential. Address Dr. R. V. Pierce, Buffalo, N. Y.

Thousands of women who have taken advantage of Dr. Pierce's offer of free consultation by letter have expressed their pleasure at the escape thus afforded from the unpleasant questions, the indelicate examinations and offensive local treatments which some of their friends had submitted to at the hands of their local physicians.

**WOMANLY CONFIDENCE**

In Dr. Pierce's methods and medicines is strengthened by his success. As chief consulting physician to the Invalids' Hotel and Surgical Institute, Buffalo, N. Y., Dr. Pierce, assisted by his staff of nearly a score of skilled physicians, has in the past thirty years and over treated and cured more than half a million women. There is no similar offer of free medical advice made to women which can show such an extended and unbroken record of success in the treatment and cure of womanly diseases.

"Favorite Prescription" contains no alcohol, and is altogether free from opium, cocaine and other narcotics.

The practice of some unscrupulous dealers of trying to substitute a less meritorious medicine for Dr. Pierce's Favorite Prescription should be promptly rebuked by the customer. It is a dangerous practice, many substitutes being heavily loaded with harmful narcotics. "Favorite Prescription" can be absolutely relied on. It always helps. It almost always cures.

**THE WIFE'S OWN BOOK**

would be a good title to Dr. Pierce's Common Sense Medical Adviser. For while the book is for the whole family, it contains so much of particular interest to women who have the care of a home, that it is of especial value to every wife and mother. The book is given away. It is a large book, containing 1,008 pages, and is sent free on receipt of stamps to pay expense of mailing only. Send 31 one-cent stamps for the book in stout cloth binding, or only 21 stamps for the paper-covered volume. Address Dr. R. V. Pierce, Buffalo, N. Y.

**"LOW RATE HOME SEEKERS' EXCURSIONS**

The Missouri Pacific Railway and Iron Mountain Route are now running a series of excursions to the West and Southwest, tickets on sale April 3d and 17th, at very low rates. Maps, folders, time-cards and illustrated pamphlets on the various states mailed free on application to H. C. Townsend, G. P. and T. Agent, St. Louis.



A Reliable Electric Belt At a Reasonable Price

THE HEALTH BELT

Dr. A. Owen's Electric Belt



Scientifically made and practically applied. All of the beneficial results that it is possible to obtain from Electricity can be had by using a Dr. Owen Electric Belt.

Have you nervous debility? Threatened with brain fog? Is there functional derangement of any of the organs of the body, due to overwork or disregard to the laws of health? If so, we offer you in

The Dr. A. Owen Electric Belt that which is yearly curing thousands even where medicines have failed.

Call or send for our large Illustrated Book, which treats fully and scientifically on how to cure yourself at home with electricity.

The Largest, Oldest and Most Reliable Electric Company in the World

THE OWEN ELECTRIC APPLIANCE CO., 201 to 211 State Street, Chicago, Ill.

OUR PRICES ON ELGIN, WALTHAM and GOLD-FILLED WATCHES. Warranted 20 Years, ARE THE LOWEST. Before you buy it will not cost you a cent to examine this great bargain Watch and Chain, complete, \$4.50. CUT THIS OUT and send it to us with your name, post office and express office address and we will send you C.O.D. for examination this beautifully engraved 14k double hunting case, gold plated, stem wind and stem set watch fitted with a richly jeweled movement, guaranteed a perfect timekeeper and equal in appearance to any \$35.00 watch. A long gold plated chain for ladies or vest chain for gents and our 20 year guarantee sent with each watch. After examination if you are satisfied it is a great bargain pay the express agent our special price \$4.50 and express charges and it is yours. Mention if you want gents' or ladies' size. DIAMOND JEWELRY CO., CHICAGO, Ill., Dept. A18, 225 Dearborn Street.

HARTMAN STEEL ROD PICKET FENCE



Fills completely all fence requisites as to beauty, utility and durability. Specially designed for lawns, parks, cemeteries, school grounds, etc. Looks best and is best when built with our steel posts. Illustrated catalog free. HARTMAN MFG. CO., BOX 26, ELLWOOD CITY, PA. Or Room 77, 309 Broadway, New York City.



ORNAMENTAL FENCE! 25 different designs, they are all steel and cheaper than wood fence. Special prices to Churches and Cemeteries. Write us for catalogue. KOKOMO FENCE MCH. CO., 427 NORTH ST. KOKOMO, IND., U. S. A.

WHERE GOES YOUR MONEY

WHEN YOU BUY FENCE? Lots of it goes into the dealer's pocket. Why not save that amount? How? Buy your fencing from us. We sell the ADVANCE FENCE direct to the farmer at wholesale. The dealer can't buy it any cheaper than you can. It is equal in quality to the highest priced fences on the market. Completely interwoven—no loose ends to unravel. Circulars and discounts free. ADVANCE FENCE CO., 116 Old St., Peoria, Ill.

NO DIRT LEFT in clothes washed with the "BUSY BEE WASHER" 100 pieces in one hour and no hard work done. That is the record. AGENTS WANTED. Exclusive sale. Write for terms, Lake Erie Mfg. Co., 116 E. 13 St., Erie, Pa.

\$5 BICYCLES CHEAPER THAN EVER from the OLD RELIABLE CO. Great Special Sale. Nearly 8000 Bicycles, every one a BARGAIN. Must be sold. All makes, 2nd h'd's, \$5 and up. Late Models new \$11.50 and up. Shipped anywhere on approval. A few more good agents wanted. Big Money. Write today for big list and special offers never before approached. BROWN-LEWIS CO. Dept. (J) Chicago, U.S.A.

FREE THIS BANGLE RING with Initial engraved, warranted to wear three years, to anyone sending us 10 cents for our Bargains in Jewelry. Shell Novelty Co., Dept. F. M., 194 Broadway, New York.

FREE CIGARS: Fifty 10c. cigars (or 100 5c. cigars) free to you. Send for particulars. ASSOCIATED BUYERS, Manhattan Bldg., Chicago.

"THE NICKEL SPEAKER" 50 cts. A YEAR. 5 cts. A COPY. 50 new pieces each month, for all grades. Toledo, Iowa.

FARM SELECTIONS

CONDENSED COW TALK

ON a good many farms the calf-pails are a sight to behold—they are cleaned when it comes handy, and it doesn't come handy very often. They smell bad, and quickly contaminate the milk, and undoubtedly are the cause of much of the trouble known as scours. A dairyman recently told us that he had solved that problem. He said, "I use a separator run by pony-power, which I start up when about half through milking. As soon as I am through there is plenty of the warm skim-milk, and I feed it in the pails I have just used for milking. As I have little mangers for the calves, the pails do not get dirty, and as they have to be washed anyway after milking, the calves always have clean, sweet milk at just the right temperature from cleanly pails, and there's no time lost on calf-pails. I don't like calves to get the sucking habit, so have a lot of little stanchions in which I fasten them as they come up to the pail. As soon as they are through drinking I give them a handful of bran or middlings and a little fine hay. After they have been here a few minutes they are let loose, but they have forgotten all about 'sucking.'"

This same dairyman, after looking over a fine barn where about eighty cows are kept, where everything is fitted up in the best style at a big expense, said, "Here's all the paraphernalia for doing a big business, and doing it well and cheaply, but it lacks in the vital point. Not over a dozen of these cows are real dairy-type animals. They are general-purpose, and not the kind of cows to produce the largest amount of milk in the cheapest manner. Better less expensive outfit and better cows."

Another shrewd farmer said, "I bought my Canada peas last fall, and intend to have thirty acres of oats and peas. I believe there will be a short hay crop next summer, no matter what kind of a season we have, and I want to be prepared for anything that may come."

At an institute one large dairyman said, "I spent \$200 for grain last summer, from which at the time I didn't seem to get back a cent, but I believed it would pay, and it has. All the fall and early winter my neighbors kept telling that their cows didn't seem to do as well as usual, and the same amount of feed wouldn't turn out as much milk. My cows were doing finely, and that \$200 has paid me back about \$180 a month for four or five months." He explained his theory by saying that "good cows in their normal condition will produce about so much milk from so much feed, but the drought last season kept pasturage so low and poor that many cows drew on their own reserve force—that is, their bodies—and got way below their natural condition. By feeding grain I kept them at normal, and when good feed came they were ready and able to respond; but those cows of my neighbors who didn't keep up are now taking it out of the feed, and it costs much more to get a cow back to her normal condition than it does to keep her at par all the time."—H. G. M., in Rural New-Yorker.

THREE FACTS ABOUT ARTICHOKE

My experience with artichokes tells me that we can rely on at least three facts; namely, (1) that artichokes—that is, the tuberous-rooted kind, Jerusalem or Mammoth French artichoke—are enormously productive. I have just taken up a few hills that sprung up in my garden where I had planted some tubers for trial the year before, and they averaged nearly a peck to the plant. I believe that on good soil one could easily grow two thousand and more bushels to the acre; (2) the next fact is that hogs and pigs are fond of this tuber, and seem to thrive on the diet; (3) the third fact, sometimes disputed by people who sell the tubers for planting, but true, nevertheless, is that artichokes where once planted are liable to come up again next year, whether you want them or not; in other words, that the plant is liable to become a troublesome weed where the best cultivation is denied to a succeeding crop, or else where the hogs themselves are not allowed to dig and completely root out the tubers.

GALVANIZED STEEL TANKS

are taking the place of wood tanks for all purposes and in all countries. They last three times as long as wood, and never leak or burst by freezing. B. F. Freeland & Sons, Middlebury, Ind., are headquarters for them. They ship them everywhere subject to inspection before payment, also feed-cookers. Drop them a card and they will send you full particulars.

- ARMSTRONG & McELVY Pittsburgh.
BEYMER-BAUMAN Pittsburgh.
DAVIS-CHAMBERS Pittsburgh.
FAHNESTOCK Pittsburgh.
ANCHOR Cincinnati.
ECKSTEIN Cincinnati.
ATLANTIC New York.
BRADLEY New York.
BROOKLYN New York.
JEWETT New York.
ULSTER New York.
UNION New York.
SOUTHERN Chicago.
SHIPMAN Chicago.
COLLIER Chicago.
MISSOURI St. Louis.
RED SEAL St. Louis.
SOUTHERN St. Louis.
JOHN T. LEWIS & BROS CO Philadelphia.
MORLEY Cleveland.
SALEM Salem, Mass.
CORNELL Buffalo.
KENTUCKY Louisville.

GET the opinion of the man behind the brush. Ask the experienced, practical painter, the man who served an apprenticeship and has thoroughly mastered his trade, what is the best and most durable paint. He will tell you pure "old Dutch process" White Lead.

The brands in margin are genuine and may be relied upon.

FREE For colors use National Lead Company's Pure White Lead Tinting Colors. Any shade desired is readily obtained. Pamphlet giving full information and showing samples of Colors, also pamphlet entitled "Uncle Sam's Experience With Paints" forwarded upon application.



National Lead Co., 100 William Street, New York.

HOW MUCH CAN I SAVE? This is a question that every man should ask himself when it comes to a business proposition. For instance, we manufacture vehicles and harness and sell them to you direct from our factory at wholesale prices. On this plan the saving to you is about 35 per cent; that is, you would have to pay local dealer or agent about that much more than you pay us for the same quality of goods. Is not this item worth saving? We make 178 styles of vehicles and 65 styles of harness and are the largest manufacturers of vehicles and harness in the world selling to the consumer exclusively. We make every article we sell and ship our goods anywhere for examination and guarantee safe arrival. You have the advantage of large selection, newest designs, latest styles, etc. Above all you have a guarantee of quality at a reasonable price. 144-page illustrated catalogue FREE. ELKHART CARRIAGE & HARNESS MANUFACTURING CO., Elkhart, Indiana.

36374 ORGANS AND PIANOS From manufactory to the home, saving all middlemen's profits. Without one dissatisfied customer. Sold on installments. Easy terms and low prices. Even though we do not sell you, our catalogue will save you money. Send for it to-day. Money refunded if instrument is not as represented after twelve months' trial. BEETHOVEN PIANO & ORGAN CO., ADDRESS BOX NO. 628, WASHINGTON, NEW JERSEY.

CABLED FIELD AND HOG FENCE. Also Cabled Poultry and Garden Fence; Steel Web Picket Lawn Fence; Steel Gates, Steel Posts and Steel Rails; Tree, Flower and Tomato Guards; Steel Wire Fence Board, etc. Catalogue Free. DeKalb Fence Co., 38 High St., DeKalb, Ill.

BULL-STRONG Seven styles. Any height desired. Made of Colled Spring Steel Wire, galvanized. The coil makes it self-regulating. It's CHICKEN-TIGHT Our Prices will surprise you. We sell direct to the farmer at lowest wholesale Anti-Trust Prices as we belong to no Combination or Trust. Catalogue and prices free for the asking. COLLED SPRING FENCE CO., Box 18 Winchester, Indiana.

ORCHARD PROFIT depends upon working all the fruit into a salable product. Cider, for instance. If good, clear and pure it sells readily at a profit. The best is produced by a HYDRAULIC CIDER PRESS Made in varying sizes; hand and power. Get our free catalogue before you buy. HYDRAULIC PRESS MFG. CO., 6 Main Street, Mt. Gilead, Ohio.

\$34 BUILT for SERVICE We Ship Direct to the consumer At Lowest Wholesale Prices the most reliable line of vehicles, etc. to be found anywhere. Built substantially of honest material—workmanship the best—one of them will outlast two of the ordinary kind—Guaranteed as represented or your money back. We will ship C.O.D. with privilege of examination. You risk nothing. Reliable Top Buggy, \$84.00; fine spring Wagon, \$89.00; strong two horse Farm Wagon, \$44.00; handsome Snarey, \$54.00; well made Portland Cutter, \$17.25; Carts, \$9.50 up. Single harness \$4.50; Farm harness, \$12.95. Send for free illustrated catalogue. CASH BUYERS' UNION, 158 W. VanBuren St., B-7, Chicago

CRESCENT FENCE will last a lifetime. Composed of all large wires and steel stays. Catalogue and prices free. Address THE C. M. FENCE STAY CO., 11 Canal St., Covington, Ohio.

Horse-High Bull-Strong Pig-Tight FENCE! Over 100 Styles, plain and ornamental. Build it yourself at the actual wholesale cost of the wire. Don't miss this GOLDEN OPPORTUNITY Write for our Catalogue and convince yourself how easily and cheaply it can be done with a Duplex Machine. KITSELMAN BROS., Box 278 Ridgeville, Ind.

ALL STEEL UP-TO-DATE LAWN FENCE. 50 DESIGNS, CHEAPER THAN WOOD FENCE. CATALOG FREE. UP-TO-DATE MFG CO., 971 N. 10th STREET, TERRE HAUTE, IND.-U.S.A.

19th or 20th Century? Take your choice, but use Page Fence on the Farm. PAGE WOVEN WIRE FENCE CO., ADRIAN, MICHIGAN.

M. M. S. POULTRY FENCE Half cost of Netting; Requires few posts, no rails. Best Hog, Farm, Yard, Cemetery Fences. Freight paid. KANSAS STEEL & WIRE WORKS KANSAS CITY, MO.

Fence Machine That weaves 50 to 100 rods per day out of barb, cable, crimped, coiled or smooth wire. Machines guaranteed. Catalogue Free. Hoosier Boy Fence Co., Indianapolis, Ind. Dept. 23

FAT How to Reduce it Mrs. L. Lanier, Martin, Tenn., writes: "I reduced my weight 2 1/2 lbs. in 15 days without any unpleasant efforts whatever." Purely vegetable, and harmless as water. ANY one can make it at home at little expense. No starving. No sickness. We will mail a box of it and full particulars in a plain sealed package for 4 cents for postage, etc. HALL CHEMICAL CO., Dept. B, St. Louis, Mo.

A GOOD WINDMILL LASTS A LIFETIME Don't buy a poor one when you can buy the IMPERIAL with patent internal gear and malleable iron frame. Write MAST, FOOS & CO., 24 River St., Springfield, Ohio

SEE AND WONDER AUTOMATIC CREAM SEPARATOR Simple; easy to operate; durable; saves half the labor. Butter-making simplified. More and better butter. Farmers' and Agents' Gold-mine. Price \$2.50; worth \$100. Send stamp for particulars. Agents wanted. Automatic Cream Separator Co., Quincy, Ill.

BUY THE BENNETT STUMP PULLER TILE DITCHER Handy Farm Wagon & CORN HARVESTER Cat. each free. H. L. Bennett, Westerville, O.

PROFITS WITHOUT CAPITAL Others are realizing good incomes with only \$10 or even \$20 capital invested. Why not you? Fair talking ability and earnest business ambition required. We do the rest. Write us immediately. The Crowell & Kirkpatrick Co., Springfield, Ohio.

I CAN SELL YOUR FARM No matter where located. Send description and selling price, and learn my wonderfully successful plan for selling farms. W. M. OSTRANDER, 1215 Filbert St., Phila., Pa.



# AMERICA SAYS SO

## The Entire Country is on the Move

### Cascarets Candy Cathartic Did It, and Record a Phenomenal Victory—Five Million Boxes Sold Last Year

From every part of America comes the news that sufferers from constipation have found relief in Cascarets Candy Cathartic, the wonderful modern scientific laxative and intestinal tonic. Cascarets are figuratively and literally in everybody's mouth. Thousands have tried Cascarets with the most pleasant and effective results, and voluntarily testify to their experiences. Here are a few extracts from some of the letters:

"I have been using Cascarets for headache and constipation, and have received great benefit from them." Mrs. M. Gabler, 512 Larrabee Street, Chicago.

"I have been taking Cascarets for over a month, and find them just the thing for constipation." Albert B. Burt, 70 Main Street, Andover, Mass.

"I am using Cascarets, and have never found anything so satisfactory." Mrs. C. W. Durrant, 57 Emerson Street, Buffalo, N. Y.

"I have taken Cascarets, and cheerfully recommend them to all my friends." Mrs. G. J. Gradwell, Frugality, Pa.

"Cascarets are fine for biliousness and malaria, and are so pleasant to take." Mrs. Mary Cummings, Maud, Oklahoma.

"I use Cascarets in my family, and find them all you recommend them to be." E. L. Irvin, Cor. Mead and Railroad, Meadville, Pa.

"You can safely add appendicitis to the list of diseases that Cascarets will benefit or cure." Eunice J. Smith, Rich Valley, Ohio.

"I have used Cascarets; there is nothing better for constipation." Benj. Passage, Knightstown, Ind.

"Cascarets are all right. They have cured me of constipation, and I never expected anything would." Charles H. Nye, Lock Box 205, Cincinnati, Ohio.

"I am so thankful for your Cascarets. They are better than any medicine I ever used." Mrs. M. Rew, Lacelle, Iowa.

"I do not hesitate to say that Cascarets is the very best medicine ever placed before the people." Andrew Woodruff, Daysville, N. Y.

"Cascarets are the best cathartic I ever used." Tom Holt, Wellwood, Manitoba.

"I have tried your Cascarets, and I want to tell you they are just splendid." John Wiegink, Box 961, Allegan, Mich.

We could fill the whole paper with expressions like the above. Thousands of similar recognitions of the merits of Cascarets have been volunteered and prove that this delightful laxative, so pleasant of taste, so mild and yet effective, has secured a firmly established place in the hearts of the people.

Go buy and try Cascarets yourself to-day. All druggists, 10c., 25c., 50c. Booklet and sample free. Address Sterling Remedy Company, Chicago or New York.

This is the CASCARET tablet. Every tablet of the only genuine Cascarets bears the magic letters "CCC." Look at the tablet before you buy, and beware of frauds, imitations and substitutes.

# TERRIFF'S PERFECT WASHER



SENT ON TRIAL at wholesale price. If not satisfactory money will be refunded. SOLD under a POSITIVE GUARANTEE to wash as clean as can be done on the washboard, even to the wrist- and neckbands of the most soiled shirt, and with far greater ease. Does not wear out the clothes. Economizes soap, labor and time. AGENTS WANTED. Exclusive territory given. Big money made. For terms and prices Address:

Portland Mfg. Co. Box 27, Portland, Mich.

# FREE Musical Parlor Clock

To successfully introduce our Eagle Havana Cigars in every county, reliable persons furnished free a Musical Parlor Clock. The clock is best American, runs eight days with one winding, strikes hours and half hours, has Winsted onyx case, with gilt ornaments, etc. The Musical Box plays automatically and produces charming selections, from operas to popular songs or hymns, and sells as high as \$25.00. To every person sending us 50 cents, and names of six cigar-smokers we will ship, securely packed, our premium offer and a sample box of our Eagle Havana Cigars, full size. EAGLE MFG. CO., 21 John Street, New York.

# WANTED MAN with horse and buggy, to sell Pasture Stock Food. Salary \$15.00 per week and 10 per cent on all sales. Farmer preferred. Previous experience not essential. PASTURE STOCK FOOD is the greatest discovery ever made in practical and scientific feeding, and is sold on an absolute guarantee. Steady, permanent trade easily established. Sample bag, sufficient for two weeks' feeding, free. Send 25 cents in stamps or silver to cover express charges. PASTURE STOCK FOOD COMPANY, 301 Boyce Building, Chicago.

Myself cured, I will gladly inform any one addicted to Morphine, Opium, Laudanum or Cocaine OF A NEVER-FAILING, HARMLESS HOME CURE. MRS. M. F. BALDWIN, P. O. Box 1212, Chicago, Ill.

# BIG COMMISSIONS TO LADY AGENTS

Lady agents for McCabe corsets and fine undershirts get generous commissions and make big money because the goods sell on sight—varying styles for different figures—prices within reach of all. Write for particulars. ST. LOUIS CORSET COMPANY, ST. LOUIS, MO.

FAMILY RECORD A beautiful picture; rich gold. Tremendous seller. Agents delighted. Sample free for 12 cents to pay postage and advertising, nine for \$1, post-paid. HOME ART PICTURE CO., Chicago, Ill.

GOLDMETER in pocket case for hunting Silver, also Rods and Needles. Circular 2 cents. B. G. STAUFFER, Dept. F. F., Harrisburg, Pa.

We Pay \$18 A WEEK AND EXPENSES to men with rigs to introduce our Poultry Compound. Send stamp. Javelle Mfg. Co., Dept. 58, Parsons, Kan.

# SELECTIONS

## THE SWISS WATCH SCHOOLS

THE famous Swiss watch schools are said to be the most exacting schools in the world. Their methods, which are doubtless the secret of their success, will be found very curious and interesting. In one of the most celebrated of these institutions in Geneva, for example, a boy must, first of all, be at least fourteen years of age in order to enter. After being admitted the student is first introduced to a wood-turning lathe, and put to work at turning tool-handles. This exercise lasts for several weeks, according to the beginner's aptitude. This is followed by exercises in filing and shaping screw-drivers and small tools. In this way he learns to make for himself a fairly complete set of tools. He next undertakes to make a large wooden pattern of a watch-frame, perhaps a foot in diameter, and after learning how this frame is to be shaped he is given a ready-cut one of brass of the ordinary size, in which he is taught to drill holes for the wheels and screws. Throughout this instruction the master stands over the pupil, directing him with the greatest care. The pupil is next taught to finish the frame so that it will be ready to receive the wheels. He is then instructed to make fine tools and to become expert in handling them. This completes the instruction in the first room, and the young watchmaker next passes to the department where he is taught to fit the stem-winding parts and to do fine cutting and filing by hand. Later he learns to make the more complex watches which will strike the hour, minute, etc., and the other delicate mechanisms for which the Swiss are famous. —Scientific American.

## CAN ANTS HEAR?

Whether ants can hear is a question which has engaged the attention of Mr. Weld, of Iowa University, for some time, and he has recently published an account of some of his experiments in science. He states that for many years it has been the accepted opinion among naturalists that these insects are not endowed with an acoustic sense, at least within the range of sounds perceptible to the human ear. The opinion is based upon the failure of experiments which showed that loud and shrill noises do not produce the slightest effect upon ants. Mr. Weld, however, finds that this was not the case with several American species of these insects. He confined an ant in a test-tube and brought it near a milled disk rotating in the air. At each sound which was produced the ant showed unmistakable signs of agitation, quickly moving its head and antennae. Shrill noises were produced close to a colony protected under a glass, and the ants immediately showed signs of alarm. These experiments lead to the conclusion that at least some species of ants are capable of perceiving vibrations conducted through the air or other media which are audible to the human ear. This does not necessarily demonstrate that they hear in the strict sense of the word, but merely that they are capable of perceiving ordinary sounds.—Scientific American.

## TROUSSEAU MAKES MAN PROPOSE

When a young man among the peasants of Bohemia thinks he likes a girl well enough to marry her he asks permission not to court her, but to see her trousseau. In anticipation of this request all young women of a marriageable age have their trousseau—the result of years of careful spinning, weaving and embroidering—placed in a large, painted box. The young man opens the box and examines its contents. If they are satisfactory he makes formal application for the girl's hand; if not, he is at liberty to go his way.

## FARM WAGON ONLY \$21.95

In order to introduce their Low Metal Wheels with Wide Tires, the Empire Manufacturing Company, Quincy, Ill., have placed upon the market a Farmer's Handy Wagon that is only 25 inches high, fitted with 24 and 30 inch wheels with 4-inch tire, and sold for only \$21.95.

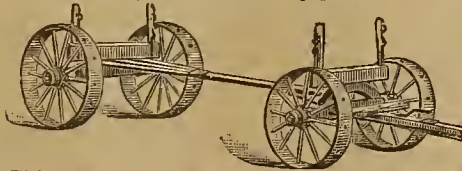

This wagon is made of the best material throughout, and really costs but a trifle more than a set of new wheels, and fully guaranteed for one year. Catalogue giving a full description will be mailed upon application by the Empire Manufacturing Co., Quincy, Ill., who also will furnish metal wheels at low prices made any size and width of tire to fit any axle.

# One Year's Free Trial

We will ship a Cornish Piano or a Cornish Organ anywhere upon the distinct understanding that, if it is not satisfactory to the purchaser after twelve months' use, we will take it back. Could anything be fairer, anything more liberal than this unique plan of selling?

**Cornish Pianos and Organs.**

This is the most liberal offer ever made. It would be impossible for us to make it if it could not be supported by the strongest evidence of our absolute reliability. We guarantee every instrument for twenty-five years, and we back up each purchase with a personal guarantee endorsed by a business reputation of fifty years, and property worth over a million dollars.

FOR FULL PARTICULARS OF THIS WORLD FAMED CORNISH PLAN, send for our New Souvenir Catalogue—a work of art with handsome colored illustrations. We send it absolutely free.

Over a Quarter of a Million Satisfied Customers.

A prompt response to this advertisement will secure a special discount from list prices of \$10 on an organ, and \$20 on a piano.

With every Cornish Piano we send a Cornish Patent Musical Attachment which correctly imitates the Harp, Guitar, Banjo, Mandolin, etc. This can only be had with the Cornish Piano.

For references, consult your bank, our bank, any bank.

**CORNISH & COMPANY**  
(Established 50 Years)  
Washington, N. J.

**\$25 upwards**

**\$55 upwards**

# ASTHMA

FREE. If you suffer from any form of Asthma we want to send you free by mail, prepaid, a Bottle of the famous Kola Plant Compound. It is Nature's Sure Botanic Cure for the disease, and we guarantee that it will forever stop all your suffering. We are sending out 50,000 bottles free by mail to sufferers, to prove the wonderful power of this New Discovery, and we will be pleased to send one to you. Send your name and address on postal card. Address, **THE KOLA IMPORTING CO., No. 1164 Broadway, New York.**

**GRAY HAIR DARKENED.**  
Osark Mountain Herbs for restoring Gray Hair to its Natural Color, Beauty and Softness. Prevents the Hair from falling out, cures and prevents Dandruff. Will not stain the scalp. Is superior to the many advertised preparations. Package makes one pint. Price 25 cents, by mail. Address **K. DUBY DRUG CO., ROLLA, MISSOURI.**

**BED-WETTING CURED.** Sample FREE. Dr. F. E. May, Bloomington, Ill.

**Coe's Eczema Cure \$1** at druggists. 25c. box of us. COE CHEM. CO., Cleveland, O.

# Knickerbocker Special

AND

## South-Western Limited

Famous Trains Between

BOSTON, CINCINNATI,  
NEW YORK, CHICAGO,  
WASHINGTON, ST. LOUIS,

VIA

# Big Four Route

AND

NEW YORK CENTRAL,  
BOSTON & ALBANY,  
CHESAPEAKE & OHIO.

Cafe, Library, Dining and Sleeping Cars.

W. J. LYNCH, W. P. DEPPE,  
Gen. Pass. and Tkt. Agt. Asst. G. P. and T. A.  
CINCINNATI, OHIO.

# PILES CURED AT HOME

By the Use of "MERTANNO"

A specific for the immediate relief and permanent cure of Blind, Bleeding, Itching and Protruding Piles. Price, postpaid 50 cents.

**Our Guarantee:** We will refund the price paid for this remedy in any case of Piles it does not cure. Send for testimonials, free.

Mertanno Pharmacal Co., 403 Scott St., Covington, Ky.

Facial Blemishes, Tetter, Salt Rheum, Barber's Itch, Scald Head, Ring Worm, Itching Piles, Sore Eyelids, and all Skin diseases promptly cured by Spencer's Ointment. Send to any address on receipt of 25c. A. O. PILSON, Pharmacist, 1327 W. Baltimore St., Baltimore, Md.

# RUPTURE

Sure Cure at home; at a small cost. No operation, pain, danger or detention from work. No return of Rupture or further use for Trusses. A complete, radical cure to all (old or young). Easy to use; thousands cured; book free (sealed). DR. W. S. RICE, Box F, Adams, N. Y.

# BEST PAY

A new line of Agency Work for either sex, easy and extra profitable; we give special advantages. Send for terms and Free Outline.

THE CROWELL & KIRKPATRICK CO., SPRINGFIELD, OHIO

THE YANKEE FIRE-KINDLER Builds 100 Fires with 3c of oil. No kindlings. Warranted 3 years. Greatest Seller for Agents ever invented. Sample with terms prepaid, 10c. YANKEE KINDLER CO., OLNEY, Ill. 37, Sta. 45.

WANTED AGENTS in every county to sell "Family Memorials"; good profits and steady work. Address Campbell & Co., 158 Plum St., Elgin, Ill.

FREE Send to EDGAR TATE & COMPANY, 245 Broadway, New York, for the most profitably interesting little Book on inventions ever written.

selling our Mackintosh Skirts and Capes Make Big Samples Free. LADIES SUPPLY CO., 109 Wabash Ave., Chicago.

PATENTS S. H. EVANS, 1010 F St Washington, D.C. Advice as to patentability free. No attorney's fee until patent is allowed. Circular free.

ANGELS WHISPER Beautiful Large Picture; Beautiful Large colored. Sells quick at 25c. Sample 15c.; 9 for \$1. J. LEE, Omaha Bldg., Chicago.

CRAZY WORK SILK REMNANTS, enough for quilt, 50c. Large package handsome colors 10c. JERSEY SILK MILL, Box 32, JERSEY CITY, N. J.

BED WETTING CURED. Trial free. Mrs. B. Rowan, Milwaukee, Wis.

H & B

# HAND-FORGED PRUNING-KNIFE

Given for a club of FOUR

This blade is hand-forged from the very best cutlery-steel, thus obtaining a toughness otherwise impossible. As far as quality is concerned there is no better pruning-knife made. It has cocobolo handles and is shaped just right to suit the hand.

Guaranteed to be as represented, first-class quality and free from defects. Any knife not fulfilling this guarantee can be returned and the money paid for it will be immediately refunded.

We will send this Knife, and the Farm and Fireside one year, for 75 Cents

(When this offer is accepted the club-raiser may have either the regular cash commission or the name may be counted in a club)

Given as a premium for a club of FOUR yearly subscriptions to the Farm and Fireside

Postage paid by us. Order by Premium No. 322

Address THE FARM AND FIRESIDE, Springfield, Ohio



RECENT PUBLICATIONS

CATALOGUES RECEIVED

Cole's Seed Store, Pella, Iowa. Annual for 1900 of garden, field and flower seeds.

Iwan Bros., Streator, Ill. Descriptive catalogue of post-hole, well-auger and drain tools.

Saginaw Basket Co., Saginaw, Mich. Handsome catalogue of all kinds of fruit-packets.

J. L. Loeb, Aberdeen, South Dakota. Descriptive catalogue of Northern-grown farm seeds.

The Monitor Co., Moodus, Conn. Illustrated catalogue of Monitor incubators and brooders.

W. C. Garrard, Secretary, Springfield, Ill. Report of the Illinois State Board of Agriculture.

The Electric Wheel Co., Quincy, Ill. Illustrated catalogue of steel wheels, wide tires, low-down wagons, etc.

Ira P. Watson, Fredonia, N. Y. Price-list of Northern-grown seed-potatoes, corn and oats, and grape-vines.

Henry A. Dreer, Philadelphia, Pa. Garden calendar for 1900. Full line of plants, bulbs and fresh, reliable seeds.

John P. Brown, Connersville, Ind. Interesting address on "The Forests of Indiana the Reliance of Her Manufactories."

W. E. Caldwell Co., Louisville, Ky. Illustrated catalogue of cypress-wood tanks, steel towers, galvanized steel water-tanks, etc.

F. R. Pierson Co., Tarrytown-on-Hudson, New York. Handsome catalogue of choice seeds, hulls and plants, imported and home-grown.

P. M. Sharples, West Chester, Pa. Calendar hanger advertising the Sharples tubular cream-separator and improved dairy apparatus.

R. Douglas Sons, Waukegan, Ill. Catalogue of hardy evergreens and shade-trees. Forest and ornamental tree seedlings by mail a specialty.

Baker Bros., Fort Worth, Texas. Illustrated leaflet describing a new evergreen, the "Rosedale Hybrid," and the "Eagle," the great Texas ever-bearing plum.

G. Camerer, Madison, Ind. Circular of two famous vineless sweet-potatoes—McKinley's Choice and Gold Coin Prolific—and Golden Wyandotte chickens.

The Kelly Foundry and Machine Co., Goshen, Ind. Calendar hanger illustrating galvanized stock watering-tanks, steel wagon-tank on low wheels, sheep-dipping vat, etc.

A. H. Griesa, Lawrence, Kan. Circular describing the new Cardinal raspberry. Illustrated in colors. Price-list of nursery stock. Report of the experimental grounds of the Kansas home nursery.

Elkhart Carriage and Harness Manufacturing Company, Elkhart, Ind. Illustrated carriages, buggies, surries, spring-wagons, harness, etc., sold direct to purchaser with privilege of examination.

The A. I. Root Co., Medina, Ohio. Illustrated catalogue of a complete line of bee-keepers' supplies. Every bee-keeper should send for this catalogue and a sample copy of "Gleanings in Bee Culture."

Ellwanger & Barry, Rochester, N. Y. Artistic catalogue of the Mount Hope nurseries in gilt cover showing a beautiful bunch of lilacs in colors, and illustrated throughout with fine half-tone reproductions from Nature.

L. W. Wakeley, General Passenger Agent Burlington Route, St. Louis, Mo. The Burlington's descriptive folder, "To California Through Scenic Colorado," a beautiful specimen of typographical and half-tone illustrated work.

SMOOTH BROME-GRASS

Austrian brome-grass (*Bromus inermis*) is a native of Europe, and one of the most promising cultivated grasses that has yet been tried on the prairies of the West. It is very hardy, enduring a very low temperature in winter, and possessing great power to produce either hay or pasture. This grass comes up quickly in the spring and makes a rapid growth, and when it has been cut for hay the aftermath is also abundant unless the weather should be abnormally dry. It sends numerous root-stalks through the soil to form fresh plants. . . . Austrian brome-grass seems well suited to the soil usually found on the prairie. In moist climates it may be too aggressive to grow with other grasses, and this property also may exclude it from permanent pasture.—From Prof. Shaw's "Grasses and Forage-Plants."

SPRAYING FRUIT-TREES

The question of spraying fruit-trees to prevent the depredations of insect pests and fungus diseases is no longer an experiment but a necessity.

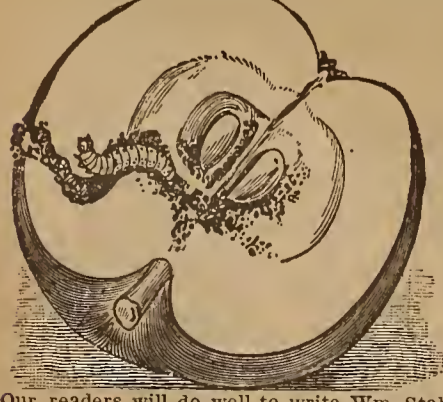

Our readers will do well to write Wm. Stahl, Quincy, Ill., and get his catalogue describing twenty-one styles of Spraying Outfits and full treatise on spraying the different fruit and vegetable crops, which contains much valuable information, and may be had for the asking.

**CALL ON OUR AGENT**

The machines by which other machines are **MEASURED** always bear the name

# McCORMICK!

McCORMICK HARVESTING MACHINE CO., CHICAGO—LARGEST WORKS AND LARGEST OUTPUT IN THE WORLD.

## THE TEN ACRE FARMER—

or the successful fellow who does his farming with one horse will find nothing equal to the "PLANET JR." Horse Hoes for his purpose. They are capable of the greatest variety of work and do it all perfectly. This one has double levers—one controls depth and the other width. A great variety of attachments. Remember that the "PLANET JR." was the original iron frame Horse Hoe. It was made the best at the start and has ever remained the best. Beware of imitations; insist on getting the genuine "PLANET JR." for nothing is so good.

We make a complete line of Seed Drills and Wheel Hoes (25 styles), Pivot Wheel Cultivators, Sugar Beet Drills and Four Row Sugar Beet Cultivators, Spring-tooth Orchard Cultivators, etc., each with a variety of attachments all of latest and most approved patterns. Our new 1900 catalogue is a worthy successor of that of '99. It is handsomer in every way, and shows what is being used by the progressive farmer at home and abroad. Sixteen of the views are full page, made from actual photographs and reflect the quaint garb and customs of peoples across the seas. We have printed and are now mailing 350,000 copies. There's one for you if you write for it.

S. L. ALLEN & CO., Box 1107-F Philadelphia, Pa.

## Six Lovely Everblooming Roses Free!

To introduce our popular illustrated literary and family paper, **Good Literature**, into thousands of homes where it is not already taken, we make the following extraordinary offer: Upon receipt of only **Thirty Cents** we will send **Good Literature** for the remaining **Nine Months** of this year (April to December inclusive), and to each subscriber we will also send, **Free and post-paid**, **Six Lovely Everblooming Roses**, as follows:

- Climbing Meteor.**—The most magnificent dark crimson climbing rose in cultivation. Grows ten to fifteen feet in a season, producing in constant succession a great profusion of magnificently-formed buds and flowers. Charming for pillars and porches.
- White Rambler.**—The finest white climbing rose yet introduced. The flowers are pure white, sweetly scented, and produced in splendid, large clusters, remaining on the bush from three to five weeks. Perfectly hardy and attains a growth of eight to ten feet in a season.
- Enchantress.**—A charming tea rose. Blooms with great freedom, bearing large globular, double flowers in clusters. Color, creamy white, with buff center.
- Burbank.**—A beautiful, deep rich pink hardy ever-blooming rose. Blooms profusely from spring until frost. Flowers are double, and three inches across.
- Roger Lambelin.**—A lovely variegated rose. Flowers deep crimson edged with white, and fringed like a double petunia. A striking novelty.
- Millie Helena Cambler.**—A new and beautiful hybrid tea rose. Color, a rich salmon, varying to apricot yellow. A prolific bloomer; flowers large and double.

Bear in mind that we offer, not one, but the entire list of six lovely ever-blooming tea and hardy roses described above absolutely free, by mail post-paid, if you will send us thirty cents for **GOOD LITERATURE** for the remaining nine months of this year (April to December inclusive). You will get the full worth of your money in your subscription to the paper; the roses are an absolute gift. Remember that these are not cheap, common roses, such as you see advertised at low prices. They are the choicest and most famous varieties, and such as are sold at high prices by all the leading florists. We shall send you strong, healthy, well-rooted plants, well packed, by mail, guaranteed to reach you in perfect condition, and to give absolute satisfaction. **GOOD LITERATURE** is a large and handsome illustrated literary and family paper, each issue comprising from 20 to 24 large 4-column pages, including a beautiful cover. You will be delighted with it, and the six lovely roses are worth many times the price of a subscription. Perfect satisfaction guaranteed or money refunded. This is a special offer by a well-known and reliable publishing house, established nearly twenty-five years; we refer to the Mercantile Agencies and to all leading newspapers as to our responsibility. Address: **F. M. LUPTON, Publisher, 23, 25 and 27 City Hall Place, New York.**

## GRINDSTONE COMPLETE WITH FRAME \$1.90 EACH.

Upon receipt of \$1.90 we will forward, properly packed, one celebrated **BUENA VISTA GRINDSTONE AND FRAME** Complete, which we warrant to be absolutely Unexcelled as to quality, finish and durability. This celebrated stone is the highest quality on the market and will be found excellent for any grade of work. We use nothing but first grade stones. They weigh from 40 to 60 pounds. In order to save our freight charges, we will ship knocked down. It is simply constructed and can be readily put together.

We carry all kinds of grind stones. Write for free catalogue No. 34 on merchandise bought at Sheriffs' and Receivers' Sales. **OUR PRICES ARE ONE-HALF OF OTHERS.** CHICAGO HOUSE WRECKING CO. West 35th & Iron Sts., CHICAGO.

## Deal with the Makers

When you buy a carriage, buggy or harness. Choose from the biggest stock and fullest assortment, and pay only the cost of making, with but one moderate profit added. Our plan of selling direct from the factory insures satisfaction—your money back if you're dissatisfied with your purchase—and enables you to **save the dealer's profit.**

Our complete illustrated catalogue, showing many styles of high grade vehicles, harness, and horse equipments, with detailed descriptions of each, mailed free. Write for it and learn how cheaply you can buy when the jobber's and dealer's profits are cut off.

**THE COLUMBUS CARRIAGE AND HARNESS CO., Columbus, O.**

## For Any Soil

For soft or rocky ground, the harrow that does the best work and draws easiest is **Hench and Dromgold's** riding or walking **Spring Tooth Wheel Harrow**

Send for free catalogue of best harrows, cultivators, corn planters, grain drills, etc.

**HENCH & DROMGOLD, York, Pa.**

## HOT SPRINGS, ARK.

VIA IRON MOUNTAIN ROUTE

The World's Sanitarium and All-Year-Round Pleasure Resort, reached only via this line. Elegant Hotels; Sublime Scenery; Delightful Climate; Healing Hot Springs. Pullman Buffet Sleeping Cars, without change, from St. Louis. Reduced Round Trip Rates all year round, from all coupon points in the U. S. and Canada.

For descriptive and illustrated pamphlet, write Company's agents, or H. C. TOWNSEND, General Passenger and Ticket Agent, ST. LOUIS, MO.

## FIRE, WEATHER, and Lightning Proof

Black, painted, or galvanized metal ROOFING and siding; (brick, rock or corrugated)

### Metal Ceilings and Side Walls

in elegant designs. Write for Catalogue.

The Penn Metal Ceiling and Roofing Co., Ltd., 23d & Hamilton Sts., Phila., Pa., or 24 Harcourt St., Boston, Mass.

## SPECIAL 60 DAYS' OFFER

TO INTRODUCE OUR LATEST LARGE, POWERFUL, ACHROMATIC TELESCOPE AND MICROSCOPE COMBINED, THE EXCELSIOR.

5 TO 10 MILE RANGE JUST WHAT YOU WANT AS A TELESCOPE OVER 3 1/2 FEET LONG

ON SEA FARM OR RANCH

# 99 CENTS

## FREE FREE FREE SEND NO MONEY

**TO LADIES, BOYS AND GIRLS** we will send 15 packages of our "Dovenshire" finest Imported English Sachet Perfume—most exquisite, fragrant lasting Perfume known, put up in a most attractive manner. You easily sell the Perfume among your friends and neighbors at 10c a package; after sold, send us the money, \$1.50, and we will send you absolutely **FREE** for your trouble **ALL** the following valuable presents: A magnificent **SOLID GOLD** or **SILVER** plated Bracelet, beautifully engraved, with lock and key; also 3 extra gold or silver Friendship Hearts; also a very beautiful large stone set Scarf or Stick Pin, and also a set of the latest style gold plated Ladies' Dress or Beauty Pins, each Pin set with exquisite **LARGE** Jewel. Just send your name and address, **NO MONEY**, and we will send the Perfume postpaid. We pay all postage and take back unsold goods. Our Sachet Perfume is the best fastest selling article you ever handled. It sells on sight! Our large 20-page Premium List of gold Watches, Jewelry, Tea and Dinner Sets, etc., free with each lot. This is by far the most liberal and grandest offer ever made. **Doubt It? Try It! Costs you nothing—that's fair.** **STANDARD IMPORTING CO.** This firm is well known for its honest goods and valuable premiums. Dept. A 28, St. Louis, Mo.

**EXCELSIOR TRADE MARK REG.**

POSITIVELY such a good Telescope was never sold for this price before. These Telescopes are made by one of the largest manufacturers of Europe, measure closed 12 inches and open over 5 1/2 feet in 5 sections. They are BRASS BOUND, BRASS SAFETY CAP on each end to exclude dust, etc., with **POWERFUL LENSES**, scientifically ground and adjusted. **GUARANTEED** by the MAKER. Heretofore Telescopes of this size have been sold for from \$5.00 to \$3.00. Every sojourner in the country or at seaside resorts should certainly secure one of these instruments; and no farmer should be without one. Objects miles away are brought to view with astonishing clearness. **THEN, PRESTO!** It can be changed to a powerful Microscope to examine seeds, insects and infinitesimal matter of any sort. This wonderful instrument sent by mail or express, safely packed, prepaid, for only 99 cts. Our new catalogue of Watches, etc., sent with each order. This is a grand offer, and you should not miss it. **WE WARRANT** each instrument **JUST AS REPRESENTED** or money refunded. **WHAT OUR CUSTOMERS SAY.** Could tell the time on a tower clock 4 1/2 miles away.—**LOTUS O'NEAL**, Ostrville, Ind. Saw houses 18 miles away.—**RUSSELL CROWELL**, Bluff Creek, Ia. Cannot get one here as good for \$5.00.—**F. ROSE**, Pulaski, N. Y. Could count sheep 4 miles away.—**C. O. GARDNER**, Woods, O. An astronomical student writes us he could see the rings on the moon with our Excelsior Telescope. Send 99 cents by Registered Letter, Post Office Money Order, Express Money Order or Bank Draft payable to our order, or have your dealer order for you. Address **EXCELSIOR IMPORTING CO., DEPT. E 299, BROADWAY, NEW YORK.**



# Thrifty, Live Plants Free

**Either 4 Geraniums, or 5 Roses, or 6 Carnations, or 6 Chrysanthemums Given for a Club of TWO Yearly Subscriptions to the Farm and Fireside**

**... Or Either Collection, and the Farm and Fireside One Year, for 50 Cents . . . . .**

By ordering many months ahead and having 25,000 of each of these collections grown especially for our use we were enabled to get them at practically the cost of production. To induce subscriptions and clubs we now offer these plants as premiums in connection with the FARM AND FIRESIDE at just what they cost us. *All of the plants will be large, healthy and well rooted, and will bloom the coming season.* We guarantee them to be exactly as described, to arrive in perfect condition, and to give entire satisfaction or your money cheerfully refunded.



## 6 Fragrant Carnations

**"THE DIVINE FLOWER"**

Carnations are the delight of every one who has an eye for the beautiful in flowers. Whether for personal adornment or to decorate the home they are unsurpassed in their charming appearance. Being unrivaled in their delicately rich and refreshing fragrance, unequalled for brilliancy, richness and diversity of colors, unapproached for daintiness and beauty of outline, it is not to be wondered at that next to the Rose they have become the favorite flower among all classes. The collection we offer contains a fine variety of these exquisite plants. If the plants of this collection were bought singly they would cost at least 50 cents. Order by Premium No. 534.

### SIX DIFFERENT COLORS, AS FOLLOWS:

One yellow, one deep crimson, one rich scarlet, one white, one light pink striped with a darker shade, and one bright rosy pink.

## 4 Beautiful Geraniums

### DOUBLE AND SINGLE FLOWERING

The Geranium has been wonderfully improved during the past few years. New colors, new styles and profusely blooming sorts have been developed. The collection here offered includes the latest and best varieties of this popular flower. They are unusually fine year-old plants. Order Geranium Collection by Premium No. 290.

### FOUR DIFFERENT COLORS, AS FOLLOWS:

One pure snow-white, one splendid crimson-scarlet, one rich salmon, and one beautiful pink.

## 5 Ever-blooming Roses

**Wonderful New Climbing Rose.. Empress of China** This is a new Climbing Rose of the greatest excellence. It commences to bloom in May, and is loaded with its elegant blooms until December. The greatest objection to climbing Roses has been that they bloom once and then are done. But here we have a Rose that blooms continuously for over seven months of the year. It is simply wonderful. When it first opens the flower is a beautiful red, but soon turns to a lovely light pink, and it blooms so profusely as to almost hide the plant. Order Rose Collection by Premium No. 470.

### THE COLLECTION OF 5 ROSES INCLUDES ALL OF THE FOLLOWING COLORS:

One Empress of China as described above, one clear bright rosy red, one bright pink, one pure white, and one rich flesh-colored. All will bloom freely during the coming season.

## 6 Chrysanthemums

**ALL DOUBLE-FLOWERING**

The collection here offered is made up of large, **double-flowering** Japanese Chrysanthemums, the direct offshoots of famous **prize-winning** varieties. This collection embraces *all colors known to the Chrysanthemum family*, and all shapes and forms, as incurved, recurved, twisted, whorled, ostrich-plumes, etc., also early and late bloomers. Order Chrysanthemum Collection by Prem. No. 558.

### SIX DIFFERENT COLORS, AS FOLLOWS:

One deep golden yellow, one rose-pink with soft satin finish, one fiery red, one violet-rose with silky texture, one pure ivory-white, and one creamy white showing a tinge of pink.

**ORDER NOW.** It is almost certain that we will receive orders for more plants than the florists have agreed to furnish. Do not wait until you are ready to plant. If you do not want your plants until some later date, we will have them reserved and shipped when desired. When you order state the time you wish the plants sent. When the supply of plants is exhausted money will be refunded.

We will send EITHER the Collection of 4 Geraniums, 5 Roses, 6 Carnations, or 6 Chrysanthemums, and the Farm and Fireside One Year, for . . . **50 Cents**

(No more than one collection with one yearly subscription. When the above offer is accepted the club-raiser may have either the regular cash commission or the name may be counted in a club)

**Free** We will send either the collection of 4 Geraniums, 5 Roses, 6 Carnations, or 6 Chrysanthemums FREE for a club of TWO yearly subscriptions to the Farm and Fireside; or any two collections for a club of FOUR; or any three collections for a club of SIX, and so on . . . . .

Postage on the plants paid by us in each case Address FARM AND FIRESIDE, Springfield, Ohio



### HOW TO GROW

Full instructions how to plant and care for them will be sent with each box of plants.



"Inasmuch as ye have done it unto one of the least of these, my brethren, ye have done it unto Me." Matt. 25: 40.

# Starving India's Pitiful Cry for Bread

## What Will Christian America Do for Poor India's Starving Millions?

### Statistics that Stagger Many Millions of Starving People —Multitudes at Death's Door



One of the Least of These

THE most pitiful, most heartrending cry for bread that has ever escaped human lips or reached human ears comes from famine-smitten India's sorely distressed and greatly afflicted people. Many millions of human beings are in various stages of starvation, and a considerable proportion of these at death's door! The greatest catastrophe of the closing century is now being enacted, and unless help comes speedily to India's relief, **Millions** of men, women and children, principally of the **farming** communities, **must die** before the next crop is harvested.

\* \* \* \*

Three months ago the Government placed the number of affected at thirty millions; to-day it admits that this estimate was too low, and that double the number would probably be nearer the truth. Five millions of these people are now employed by the Government at wages averaging two cents a day each, but the remainder must be relieved by private charity or succumb to starvation. England is doing nobly, but she is not equal to the occasion, and America, with her overflowing, bursting granaries, must speedily come to the rescue or these millions will perish from the very lack of what we enjoy in superabundance.

\* \* \* \*

### A Noble Record

Christian America has never yet turned a deaf ear to the pitiful cry of agonizing despair. Ireland, Russia, Armenia, Cuba, Porto Rico, and India itself bear eloquent witness to her generous and prompt responsiveness to every worthy appeal, and in this calamity, greater than any yet witnessed, she will unquestionably prove herself worthy the noble record of the past, and share in generous measure the abundance wherewith she has been so bountifully blessed.

\* \* \* \*

### Help Them to Help Others

Missionaries now working in India have been so affected by the scenes of heartrending suffering which they have been compelled to witness that, though their hearts are breaking, their tears refuse to flow. They themselves have given all they had and all they could borrow and now they are daily inditing pathetic communications, and sending them broadcast with the fervent prayer that God would move the hearts of their more fortunate

brothers and sisters in distant lands to contribute largely in this hour of India's direst need, and thus help them to help those who are looking to them for salvation from impending death.

\* \* \* \*

### Looking This Way

For many years these godly men and women have pointed the people to the Saviour, and countless thousands have accepted him and have been baptized in the Faith. Indeed, the cause of Christ is making wondrous progress among the dense and dusky population of India, and now that disaster has befallen them and death is threatening them, what wonder that they are hoping for help from this country whence hail the missionaries who have told them again and again the beautiful story of one Jesus who went about doing good, who fed the multitudes, and whose followers in this prosperous country are walking in the footsteps of their Master, daily testing their

### A Safe Investment

"He that hath pity upon the poor lendeth unto the Lord; and that which he hath given will he pay him again."

Let us each and every one make this investment, and lend to the Lord all we can possibly spare, and in due time he will repay all that we have lent him. How many lives will **you** undertake to save? Send us word quickly lest they perish before relief can reach them.

\* \* \* \*

### The Land of His Birth

This pathetic cry for bread comes from the continent of Asia, concerning which Dr. Talmage says:

Egypt gave to us its monuments, Rome gave to us its law, Germany gave to us its philosophy, but Asia gave to us its Christ. His mother an Asiatic; the mountains that looked down upon him, Asiatic; the lakes on whose pebbly banks he rested and on whose chopped waves he walked, Asiatic; the apostles whom he first commissioned, Asiatic; the audiences he whelmed with his illustrations drawn from blooming lilies and salt crystals, and great rainfalls, and bellowing tempests, and hypocrites' long faces, and croaking ravens—all those audiences Asi-



FAMINE CHILDREN PLUCKED AS BRANDS FROM THE BURNING  
Photographed at the American Mission House of Rev. E. S. Hume, Byculla

lives by the standard he established, and ever asking themselves, **What would Jesus do?**

\* \* \* \*

### Help Them Quickly

And shall they look in vain? Shall they be disappointed? Shall we lead them to believe that our religion is mere profession? Shall we shut up the bowels of our compassion and tell them that American money and American grain are for Americans only—that religion is one thing and charity quite another? Or shall we open up our hearts, our hands, our purses and our granaries, and in the name of our Master whom we serve bid them share with us the bounties of our Heavenly Father's goodness?

\* \* \* \*

### Two Cents a Day

**Two cents** a day will support a life. **One dollar** will keep a man, woman or child two months from starvation. **Ten dollars** will save five lives for four months.

atic. Christ during his earthly stay was but once outside of Asia.

\* \* \* \*

### A Flying Relief Ship

The Secretary of State for India has cabled to THE CHRISTIAN HERALD that his government will pay transportation charges if America will speedily send a cargo of corn, and already arrangements are under way to have a capacious vessel laden with life-saving American grain start from the harbor of New York at an early date.

\* \* \* \*

### Your Opportunity

All may help in this blessed work. Every contribution, however small, will be heartily welcomed and promptly acknowledged in the columns of The Christian Herald. If we can secure a million bushels of corn of the 2,500 millions harvested last year, we can fill ten

ships, and the greatest life-saving fleet ever organized will speed across the waves and bring hope and life for four months to a million men, women and children.

\* \* \* \*

### Let All Join Hands

Let every village be represented. Let every Church, Sunday School, Home and Foreign Mission Society do its share. Let Sunday School Officers, Teachers and Scholars vie with each other in hastening to the rescue of this unfortunate people. Let farmers organize and send car-loads of corn. This is the greatest opportunity of the closing century to do good in the Master's name. We are His almoners. He gave up all for us, and now through these starving ones he claims a share of what he has entrusted to our care. Are we unjust stewards? God forbid!

\* \* \* \*

### Help or They Perish

We urge upon every reader of The Farm and Fireside to join the life-saving crew and to throw out to these starving people the life-line, before it is too late. Send to us for **mite boxes** and collect funds. Fill a car with corn and send to us for instructions. **If you cannot pay freight charges The Christian Herald will pay the bill.** If you cannot send corn send money. Pray that God's people everywhere may realize the importance and urgency of the case and may willingly and cheerfully give, even as God has prospered them.

\* \* \* \*

Young People's Societies, Epworth Leagues, Christian Endeavorers, work earnestly; for the night of death threatens to enshroud a continent. You can give the clouds a silver lining and you will do it. This is The King's business. It requires haste. Every day's delay may prove fatal. Let us then be up and doing. He that sitteth in the heavens watches us. His eye is upon us. What we do let us do it as unto Him, and he that seeth in secret and rewardeth openly will bless us with an everlasting blessing.

\* \* \* \*

### The Daughters of the King

There are in every community godly women, sympathetic and kind; consecrated women, who long to do good, as they have opportunity and to aid the poor, the suffering and the distressed. We look confidently to them for aid at this time. They can work, they can speak, they can plead, pray and give. May God call them to this mission and graciously prosper the work of their hearts and their hands.

\* \* \* \*

Every remittance of money and every contribution of corn will be acknowledged in THE CHRISTIAN HERALD.

ADDRESS: INDIA FAMINE RELIEF FUND,  
The Christian Herald, 245 to 254 Bible House, New York



LIBRARY RECEIVED  
 APR 16 1900  
 Department of Agriculture.

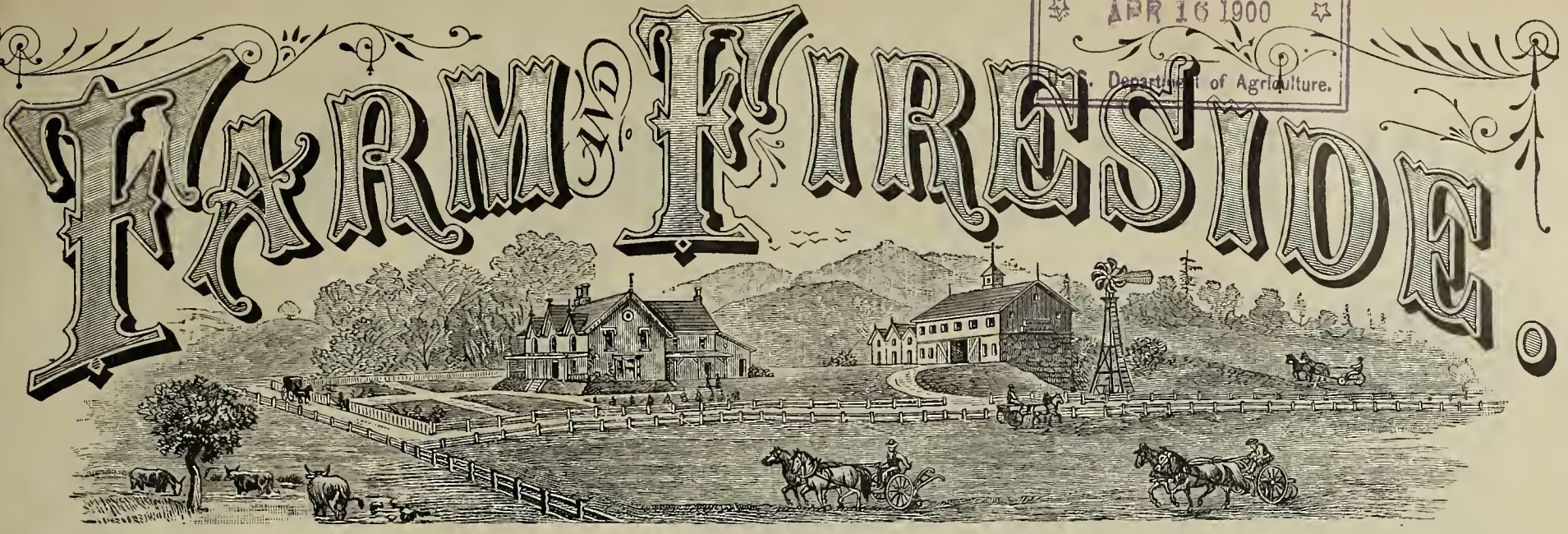

VOL. XXIII. NO. 14      EASTERN EDITION      APRIL 15, 1900      Entered at the Post-office at Springfield, Ohio, as second-class mail matter      TERMS { 50 CENTS A YEAR / 24 NUMBERS

Plain Cooking      THE STANDARD      Fancy Cooking

# American Cook Book

And the Farm and Fireside One Year, for 40 Cents

This Cook Book contains thousands of the most valuable recipes and desirable formulas by noted experts and over two hundred practical housekeepers. It covers every branch of cookery, with special directions for serving at table; also preserving, pickling, candy-making, etc.

## Plain and Fancy Cooking in Great Variety

Attention is called to the unequalled variety characterizing the recipes in this Cook Book. Practical housekeepers consider this one of the very strongest features of this new work, adapting it to universal use, and suiting every occasion, from an inexpensive home meal to an elaborately prepared entertainment for company. Largely on account of the VARIETY which it offers the ladies to select from, the Standard American is superseding all other cook books. Wherever this Cook Book is most used there it is sure to be the best liked.

*The only AMPLY ILLUSTRATED work on the cuisine within the reach of Women of America, with nearly 400 pages, 6 by 8 inches.*

## This is the Cook Book You Want

Because its plan includes the valuable and useful points of other cook books, and IN ADDITION it has inestimable features of its own entirely new. For REGULAR USE it will give you the best of satisfaction as a clear, safe, reliable, economical kitchen guide, with an abundance of good things to choose from; while for SPECIAL OCCASIONS, when the duties of hostess demand your assiduous thought, you will find it far surpasses everything brought to your notice. Every recipe has been tested hundreds, and most of them thousands, of times. This is true, also, of the rarer and more elegant dishes, such as will gratify the highest ambition of the SOCIAL ENTERTAINER and domestic provider. In developing the plan of this work the aim has been to make it practical and comprehensively useful.

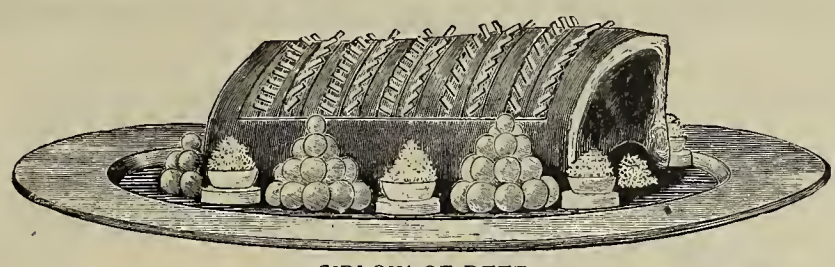

SIRLOIN OF BEEF

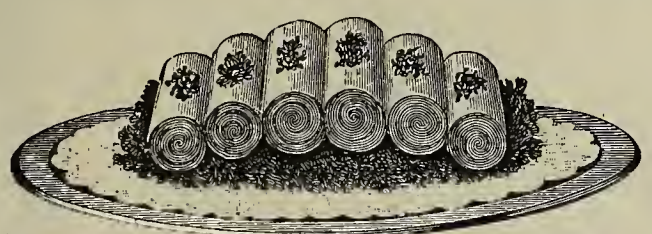

OYSTERS A LA DUMAS

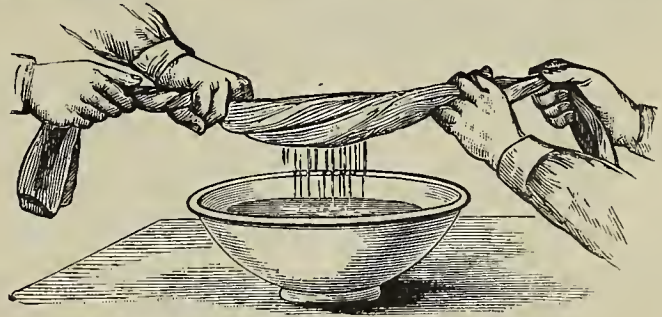

WRINGING SAUCES THROUGH THE TAMMY

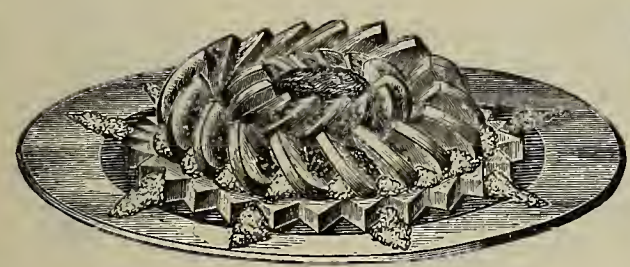

VICTORIA SANDWICHES

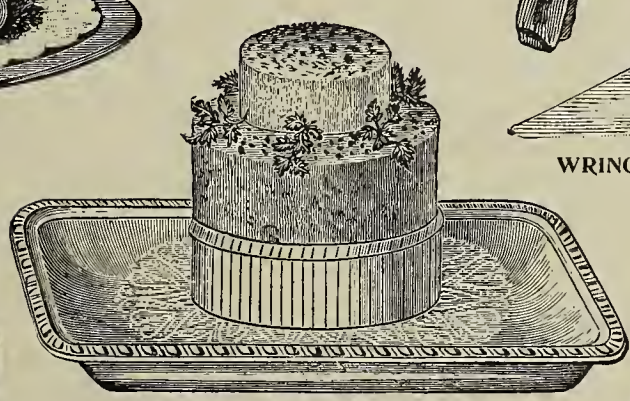

SOUFFLE A LA MARGUERITE



TURBAN OF CHICKEN

# More Than 250 Explanatory Illustrations

Making clear at a glance important processes in plain and fancy cooking. To show HOW a thing should be done amounts to far more practically than any mere bidding do it. Once accustomed to the pictorial object-teaching methods of this thorough and comprehensive work, no lady will be willing to go back to the unsatisfactory directions of other cook books. This Cook Book has a complete index.

This Grand Book, and the Farm and Fireside One Year, for . . . . . 40 Cents

*(When this offer is accepted the club-raiser may have either the regular cash commission or the name may be counted in a club)*

THIS BOOK GIVEN FREE FOR A CLUB OF TWO YEARLY SUBSCRIPTIONS TO THE FARM AND FIRESIDE

Order by Premium No. 10  
 Postage paid by us

Address FARM AND FIRESIDE, Springfield, Ohio



# OUR PHILIPPINE WONDERLAND

By Adjutant E. Hannaford

## 256 MAMMOTH PAGES....

The page is *imperial octavo size*, 10½ inches long, 8 inches wide; hence the printed surface in this great work equals that of an ordinary book containing 550 pages. Extra heavy, fine, ivory-finish paper. "Our Philippine Wonderland" *opens a new world* to American readers, giving 105,000 words of matter as interesting as the latest novel.

## 338 Magnificent New Illustrations

From photographs taken on the ground, and in size averaging almost as large as this Tagal Belle

WE WILL SEND "OUR PHILIPPINE WONDERLAND" IN WATERPROOF LEATHERETTE BINDING, AND THE FARM AND FIRESIDE ONE YEAR, FOR . . . . . **\$1.50**

(When the above offer is accepted the club-raiser may either have the regular cash commission or the name may be counted in a club)

### AGENTS WANTED

Extra liberal cash commissions and special advantages **FREE**. Send for particulars, also specimen reports from agents showing this is the **GREATEST SELLER** of the day. Come at once and get first chance, as the Philippine question is the **leading question** this year, and no other book gives one fourth as much or as interesting information. Complete success guaranteed any man or woman, even though inexperienced, who canvasses faithfully according to our instructions. A capital of \$3 is sufficient; \$20 is ample for a business of \$400 a month.

Address **THE CROWELL & KIRKPATRICK CO.**  
Springfield, Ohio



TAGAL BELLE, AND DOUBLE-STRINGED HARP WORTH \$300. (Page 47.)

## Genuine Diamond Brand Scissors...

Premium No. 147...



These are the genuine Diamond Brand Scissors, made and warranted by the largest scissors-factory in the world. They are made of fine steel, hand-forged, ground edges, tempered by experts, heavily nickel-plated, highly polished. Length 7¼ inches.

We Will Send the Farm and Fireside One Year and These Nickel-plated Steel Scissors for . . . . . **70 Cents**

(When this offer is accepted the club-raiser may have either the regular cash commission or the name may be counted in a club)

Given as a premium for a Club of Only **THREE** yearly subscriptions to the Farm and Fireside

## UNEXCELLED LADIES' KNIFE

Premium No. 150

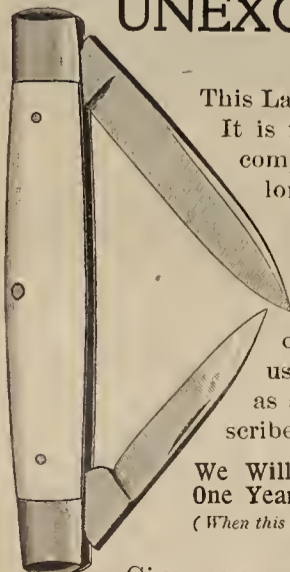

This Ladies' Penknife is neat and tasty in every respect. It is manufactured by an old reliable manufacturing company, and is guaranteed by them. It is 2½ inches long, and has two blades made of razor-steel, hand-forged, oil-tempered, carefully sharpened and highly polished. The handle is of genuine ivory, the trimmings of German silver, and the linings of brass. The cut shows the exact size and shape of the knife. Fully warranted. This knife is usually sold in stores at from 75 cents to \$1.00, but as an extra inducement to our club-raisers and subscribers we make the following very liberal offer.

We Will Send the Farm and Fireside One Year and This Penknife for . . . . . **Only 80 Cents**

(When this offer is accepted the club-raiser may have either the regular cash commission or the name may be counted in a club)

Given as a premium for a club of only **FOUR** yearly subscriptions to the Farm and Fireside.

Postage paid by us

## Sterling Silver Bracelets.....

LATEST AND MOST ELEGANT STYLES

We here offer two sterling silver bracelets of the most approved patterns. The Chain Bracelet is fitted with a lock and key. The links are the size links shown in the illustration, and are elegantly engraved. Not including lock the bracelet is 7¾ inches in length.

The Nethersole Bracelet is also sterling silver, and the quality of the same is guaranteed. As all Nethersole Bracelets are made hollow, and by careless handling may be dented, we do not guarantee them against dents, and will not exchange or replace dented bracelets. This is an elegant bracelet of good quality and is sure to be satisfactory.

Either One of These Sterling Silver Bracelets, and the Farm and Fireside One Year, for . . . . . **\$1.10**

(When this offer is accepted the club-raiser may have either the regular cash commission or the name may be counted in a club)



No. 491

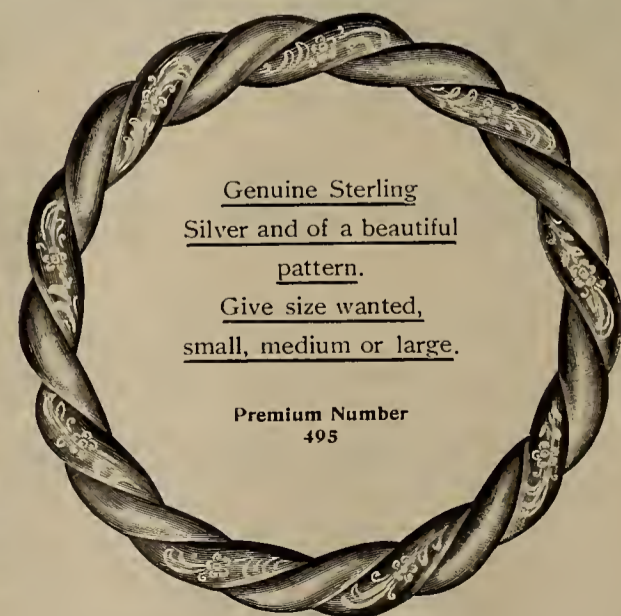

Genuine Sterling Silver and of a beautiful pattern.  
Give size wanted, small, medium or large.

Premium Number 495

Either one of these Bracelets given as a premium for a club of **SIX** yearly subscriptions to the Farm and Fireside.

ORDER BY THE PREMIUM NUMBERS

Address **FARM AND FIRESIDE, Springfield, Ohio**



# THE FARM AND FIRESIDE

## HIGH-LINE CANALS OF COLORADO

BY H. A. CRAFTS



COLORADO irrigates more than two millions of acres of land, and year by year the irrigated area increases in spite of the fact that all the available water supply, on the eastern slope of the Rocky mountains at least, has been long since appropriated. Each stream that flows down out of the mountain

nected with the ditch is a system of plains reservoirs with an aggregate storage capacity of about five hundred and thirty million cubic feet of water. But the Larimer-county ditch was one of the latest appropriations of water on the Cache la Poudre river, and the owners found it necessary, in order to carry out their plans, to secure more water than they could legally take from the natural volume of the river.

Sixty miles westward from the head works of the ditch is Chambers' lake, a tributary

the sudden influx of water therefrom caused the dam to break, and an immense body of water rushed down the canon and into the valley below, causing much damage to property along the way. The company not only lost their dam and their stored supply of water, but were mulcted in heavy damages. They took no immediate steps to rebuild their dam, but began to look elsewhere for a new source of water supply.

Within a radius of five miles of Chambers' lake are the head waters of the Big Laramie

vestigation, that by tapping the streams of the opposite watershed at certain elevations water could be brought from them across the divides to Chambers' lake and the headwaters of the Cache la Poudre; and as these streams yet carried large amounts of unappropriated water, it was decided to obtain the necessary supply from them. The first of these high-line ditches to be constructed was the Big Laramie ditch. It was started on a branch of the Big Laramie river that flows down a gulch on the north side of Mount Cameron. This branch has a discharge at flood-tide of five hundred cubic feet of water a second. The ditch was carried around the eastern flank of Mount Cameron at an elevation of ten thousand feet above sea-level, and from fifteen hundred to two thousand feet above the base of the mountain. It was built upon a side-hill composed variously of loose earth, loose rock and solid rock. The mountain-side has a slope of about forty-five degrees; so steep, indeed, is it that during the construction of the ditch it was no unusual occurrence for a mule-team engaged in scraper work to lose its footing and roll down the mountain-side to the bottom of the gulch below, not, however, with serious damage to the animals.

The constructors encountered standing timber along the line, which had to be cut away and cleared from the ditch site. The timber was utilized in building log curbing to retain the lower bank of the ditch. Across the gulches the ditch was flumed, one flume being four hundred feet in length. Then there was a tunnel to be cut through solid rock for a distance of one hundred and ten feet. But the ditch was completed in spite of all obstacles. It is five miles in length, and has an average width of twelve feet on top and eight feet on the bottom. Its carrying capacity at its head is two hundred and forty cubic feet a second, and at its outlet four hundred cubic feet a second. The size of the ditch was gradually increased as the outlet was approached, in order to receive the water flowing down the streams that were intersected.

Southwesterly of Chambers' lake and across the crest of the continental divide are the head-waters of the Grand river. They are spread out in fan-shape, and consist of numerous streams leading down mountainous gulches from the beds of snow and ice of the more lofty peaks. Here the Water Supply and Storage Co. is seeking another source of supply for their irrigating system.

The company has rebuilt its Chambers' lake dam, replacing the broken earth dam



CLEANING OUT AN EARTH-SLIDE IN THE BIG LARAMIE DITCH

gorges and upon the plains has leading from either bank a series of irrigating-ditches like the branches of a great tree. Some of the ditches are so large that they seem like rivers themselves, while others are smaller. Each ditch is entitled to its water by right of priority; that is, the oldest ditch on a given stream has the first right, and so on down the list until the newest ditch is reached, which in some cases has a very doubtful right at best, and trusts to luck to get its patrons through an irrigating season without an absolute loss of crops. Yet by the judicious employment of various means known to modern engineering even these ditches are intrenching themselves upon a solid footing.

These means imply the more economical use of water, the husbanding of the general supply and the obtaining of additional water from sources little dreamed of two decades ago. Probably the most thorough and reliable means at present employed is the construction of storage reservoirs, which may be filled during flood-tide and between irrigating seasons, and the water held in reserve for use when needed upon the growing crops. There are more than three hundred storage reservoirs in the state, having an aggregate capacity of about fifty billion cubic feet of water. There are both mountain and plains reservoirs, but the latter predominate, for the reason that they are easier of construction and less of a menace to surrounding life and property.

But the scheme that appeals most strongly to the general mind is that employed of late years for the transferring of water from one watershed to another. This implies not only the conducting of water across the lower divides, but across the continental divide itself, or the turning of water which Nature intended should run to the Pacific to the Atlantic watershed. This was first successfully accomplished by the Water Supply and Storage Co., of Fort Collins. The company is the owner of the Larimer-county ditch, one of the largest of the kind in the state. It is taken out of the Cache la Poudre river, near the foot-hills of the eastern base of the Rocky mountains, and extends out upon the plains for a distance of seventy miles. It is thirty feet wide at the top and twenty at the bottom, and has a carrying capacity of about six hundred cubic feet of water a second. Con-

of the Cache la Poudre river. This the company incorporated as a storage reservoir, and at its outlet constructed an immense earthwork dam, whereby one hundred and thirty million cubic feet of water were held in abeyance for use when it should be needed upon the crops growing far out on the plains below. By a provision of law the

river, the Michigan creek and Grand river. The Big Laramie, as any school map will show, flows northward into Wyoming, and empties into the North Platte. The Grand river flows southwestward through western Colorado, and empties into the Colorado river, which in turn flows onward to the Pacific ocean. Chambers' lake lies at an



MOUTH OF THE TUNNEL OF THE BIG LARAMIE DITCH

company was permitted to measure their reservoir water into the river, and measure out of it, at their head-gate, an equal amount less a small percentage deducted on account of seepage and evaporation while on its journey down from the lake. But one day there occurred a cloud-burst up on the mountain-sides surrounding the lake, and

altitude of about ten thousand feet above sea-level, in the midst of the snowy range. Overtopping it are mountain peaks from which the snow never entirely melts; and from the vast bodies of snow falling annually upon these upper heights the streams receive their supply of water.

The company's engineer found, upon in-

vestigation, that by tapping the streams of the opposite watershed at certain elevations water could be brought from them across the divides to Chambers' lake and the headwaters of the Cache la Poudre; and as these streams yet carried large amounts of unappropriated water, it was decided to obtain the necessary supply from them. The first of these high-line ditches to be constructed was the Big Laramie ditch. It was started on a branch of the Big Laramie river that flows down a gulch on the north side of Mount Cameron. This branch has a discharge at flood-tide of five hundred cubic feet of water a second. The ditch was carried around the eastern flank of Mount Cameron at an elevation of ten thousand feet above sea-level, and from fifteen hundred to two thousand feet above the base of the mountain. It was built upon a side-hill composed variously of loose earth, loose rock and solid rock. The mountain-side has a slope of about forty-five degrees; so steep, indeed, is it that during the construction of the ditch it was no unusual occurrence for a mule-team engaged in scraper work to lose its footing and roll down the mountain-side to the bottom of the gulch below, not, however, with serious damage to the animals.



## FARM AND FIRESIDE

PUBLISHED BY

THE CROWELL &amp; KIRKPATRICK CO.

OFFICES:

147 Nassau Street,  
New York CitySpringfield,  
Ohio204 Dearborn Street,  
Chicago, Illinois

Subscriptions and all business letters may be addressed to "FARM AND FIRESIDE," at either one of the above-mentioned offices; letters for the Editor should be marked EDITOR.

## TERMS OF SUBSCRIPTION

One Year - (24 Numbers) - 50 Cents  
Six Months - (12 Numbers) - 30 Cents

The above rates include the payment of postage by us. All subscriptions commence with the issue on press when order is received.

Subscribers receive this paper twice a month, which is twice as often as most other farm and family journals are issued.

**Payment**, when sent by mail, should be made in Express or Post-office Money-orders, Bank Checks or Drafts. WHEN NEITHER OF THESE CAN BE PROCURED, send the money in a registered letter. All postmasters are required to register letters whenever requested to do so. DO NOT SEND CHECKS ON BANKS IN SMALL TOWNS.

**Silver**, when sent through the mail, should be carefully wrapped in cloth or strong paper, so as not to wear a hole through the envelop and get lost.

**Postage-stamps** will be received in payment for subscriptions in sums less than one dollar, if for every 25 cents in stamps you add one-cent stamp extra, because we must sell postage-stamps at a loss.

The date on the "yellow label" shows the time to which each subscriber has paid. Thus: May 1900 means that the subscription is paid up to May 1900; Jun 1900, to June, 1900, and so on.

When money is received, the date will be changed within four weeks, which will answer for a receipt.

When renewing your subscription, do not fail to say it is a renewal. If all our subscribers will do this, a great deal of trouble will be avoided. Also give your name and initials just as now on the yellow address label; don't change it to some other member of the family; if the paper is now coming in your wife's name, sign her name, just as it is on the label, to your letter of renewal. Always name your post-office.

## The Advertisers in This Paper

We believe that all the advertisements in this paper are from reliable firms or business men, and do not intentionally or knowingly insert advertisements from any but reliable parties; if subscribers find any of them to be otherwise we should be glad to know it. Always mention this paper when answering advertisements, as advertisers often have different things advertised in several papers.



THE American people are in possession of Hawaii, Puerto Rico and the Philippines. What shall we do with them? Shall the people of our new possessions be subjects or citizens? Mr. Henry B. Blackwell submits the following answer: "Make these people citizens. Not citizens of the United States, nor of the states, but citizens of Hawaii, of Puerto Rico, of Luzon and the Visayan islands, organized as self-governing territories. It is a mistake to assume, as many do, that organized territories are embryo states, and must eventually be admitted as such. Not so; unless and until they prove themselves capable and worthy of such admission. We admitted California and Oregon when an American population had peopled a wilderness. But we have refused for half a century to confer statehood upon New Mexico because her population is Mexican. Yet New Mexico is contented and prosperous under our admirable territorial system, which is exactly adapted to our new possessions. Each territory has its governor appointed by the President, and this governor has the veto power; it has its courts, with judges appointed at Washington; it has its legislature elected by its inhabitants, making its own local laws, subject to congressional supervision and repeal if needed; it has its delegate sitting in our national House of Representatives without a vote. So long as it remains a territory it governs itself, but it does not govern us in any form whatever. It has reciprocal free trade with the states, and is included in our American tariff system. There is no reason why this beneficent status should not continue for centuries, or until these islands shall become thoroughly American in language, ideas and institutions.

"This condition of affairs would bring alike to ourselves and to these new possessions an unparalleled agricultural prosperity; a free interchange of temperate and tropical products, upon a scale hitherto unknown, at prices mutually beneficial; a permanent and increasing market for American manufactures; a continuous field of investment for American capital and enterprise; and a commerce such as no nation has ever before

enjoyed. This natural commerce between the temperate and torrid zones would create a fleet of American vessels not dependent upon subsidies for prosperity, and would vastly enlarge the traffic upon our railroads, canals and lake and river steamers. Our flour, beef, pork, mutton, cattle, hay, wheat, corn, oats and dairy products, our cotton and linen goods, machinery, agricultural tools, hardware, coal, petroleum, lumber, building material and a thousand articles of comfort, taste and luxury, would be freely exchanged for sugar, tobacco, tea, coffee, chocolate, rice, India rubber, mahogany, hemp, jute, spices and tropical fruits, all of which would be supplied at far lower prices than now prevail. Compared with these widely diffused benefits to consumers the loss of sugar duties, the opposition of the sugar trust and the outcry of a few would-be monopolists of tobacco and oranges are insignificant indeed.

"Moreover, it would secure in our new possessions permanent loyalty to the flag and universal satisfaction based upon general prosperity and enlightened self-interest. It would bring about an eventful unity of language, laws, manners and institutions with our own. The only way to govern wisely these now alien communities is to enable them to govern themselves as territories under congressional supervision."

IN AN article in "Leslie's Weekly" on the situation in the Philippines General Joseph Wheeler says: "I believe that the back of the rebellion in the Philippines is broken. There will be little more to do in a military way. There will be some guerrilla warfare, but it will not amount to much.

"As for Aguinaldo, I do not consider him a patriot. He was fighting for a great prize. Had he won he would have been a powerful emperor, a mighty dictator.

"As far as possible I believe that we should establish civil government in the Philippines. I am in favor of territorial government, and I see nothing incongruous in making these various islands into territories. The group should be divided into three or four territories. Not only because of the extent of the islands, but because of the antagonisms existing between the different peoples. Some of these tribes have been our devoted friends, and it would be most unfair not to give them the right of self-government. Many of them are already fit for self-government in local affairs, and under territorial governors appointed by us they would get along very well, I am sure.

"I consider the Filipinos a very superior people—a people with great possibilities. They are ambitious, and many of them have been finely educated in Europe; they are not to be spoken of in the same breath with the Africans, so far as their possibilities go. They are, too, easily governed, and with the fair treatment which they will receive from us we shall have no trouble with them. They appreciate consideration, I have found, but they are sensitive and are unwilling to be treated as inferiors. They are a little distrustful of us.

"On the question of ultimate annexation or the remote future of the Philippines—whether states would be erected there or not, in case we annex the islands—I am not yet prepared to speak, but I do think that we owe much to the many citizens of the islands who are not Filipinos, and especially to those Filipinos who have been friendly to us. If our army were to be withdrawn from the islands the natives who have befriended us would be subjected to all sorts of persecutions, and many of them would meet death, all on account of their kindness to us."

SENATORS Platt, Aldrich and Teller, a Senate subcommittee, personally visited Cuba and investigated conditions on the island. Concerning their observations the chairman of the committee says:

"We inquired as carefully and completely as we could, with the limited time at our disposal, into the condition of the people of the island, their needs, and the prospect of the establishment of an independent, satisfactory and stable government by and for the people of Cuba. We were in Havana in all five days. We also visited the provinces of Pinar del Rio, Matanzas and Santa Clara, being unable to go to Santiago and Puerto Principe, as we very much wished. We saw

and conversed with a great many prominent and leading men from all portions of the island, men who represented different ideas and interests, from intense conservatism to decided radicalism, and return with a much better understanding of the problem to be solved and the steps to be taken in its solution than we could possibly obtain otherwise than by a personal visit.

"It may be said of all classes in Cuba that they are looking to the establishment of an independent government, a Cuban republic. A few are impatient, and wish for immediate and complete independence. Others are less impatient, believing that sufficient time should be taken to avoid mistakes, and to set up the new government upon such a firm basis as to insure its success and permanence. All are looking forward to the municipal elections that are to take place in the latter part of May, regarding such elections as the first step toward the establishment of the new government. Much will depend upon the result of these elections. If they take place without disorder, and good officials are elected, that will go far to prove the capacity of the people for self-government, and steps can be taken without great delay for further progress in that direction. The problem is complicated by the fact that self-government is an untried experiment by a people who have had little opportunity to study its principles or its details, its necessities or its responsibilities. Many of the more conservative citizens and business men, unfortunately, show too much disposition to hold aloof.

"We were much impressed by the evidences of good administration of the affairs of the island under Governor-General Wood. He has a very difficult and complicated problem to deal with—conditions growing out of three hundred years of Spanish misrule, and the consequent character of the people of Cuba makes every step in its solution embarrassing; but we are convinced that he is the right man in the right place, and that his administration, though firm, is as gentle as possible, and calculated to lead the people wisely to the establishment of an independent government which shall have close relations with our own, and in which the interests both of the people of Cuba and the United States shall be surely subserved. It is not too much to say that the people of Cuba, in respect to the formation of a stable and beneficent government, are very much like children who have to be taught and led. They regard the United States as their friend and teacher, and as a whole are quite willing to be guided.

"There are great possibilities in the island. It is fertile, has great natural resources, and is capable of supporting a population four or five times larger than it numbers at present. On the whole there has been marvelous recuperation since the declaration of peace, but it needs American capital and American enterprise, which hesitates as yet to go there. English and German capital seems more confident, and is being invested. Surely our own people ought to have as much confidence in the future of Cuba as foreigners have. On the whole we were much pleased and encouraged. The people of the United States and of Cuba should alike exercise patience, being assured that thereby progress will be most certain."

THE Grout bill pending in Congress reads as follows: "All articles known as oleomargarine, butterine, imitation butter or imitation cheese, or any substance in the semblance of butter or cheese not the usual product of the dairy and not made exclusively of pure and unadulterated milk or cream, transported into any state or territory, and remaining therein for use, sale, consumption or storage therein, shall, upon the arrival within the limits of such state or territory, be subject to the operation and effect of the laws of such state or territory enacted into the exercise of its police powers to the same extent and in the same manner as though such articles or substances had been produced in such state or territory, and shall not be exempt therefrom by reason of being introduced therein in original packages or otherwise, 'provided,' that nothing in this Act shall be construed to permit any state to forbid the manufacture or sale of oleomargarine in a separate and distinct form and in such manner as will advise the consumer of its real character, free from coloration or ingredient that causes it to look like butter.

"SECTION 2. That after the passage of this Act the tax upon oleomargarine, as prescribed in section eight of the Act approved August second, eighteen hundred and eighty-six, and entitled 'An act defining butter, also imposing a tax upon and regulating the manufacture, sale, importation and exportation of oleomargarine,' shall be one fourth of one cent a pound when the same is not colored in imitation of butter; but when colored in imitation of butter the tax to be paid by the manufacturer shall be ten cents a pound, to be levied and collected in accordance with the provisions of said Act."

Explaining why Congress is appealed to, Secretary Knight, of the National Dairy Union, says: "In coming to Congress for assistance to put an end to the most gigantic system of fraud and lawlessness ever built up in any country the dairy interests are appealing to the general government as a last resort to do something which the states have exhausted every effort in an endeavor to do, but now realize that only the general government can accomplish. The very nature of the compound oleomargarine is such that it can only be controlled through an agency which can keep it under surveillance from the moment it is manufactured until it goes into the hands of the consumer."

Among the reasons given in favor of the Grout bill are the following:

"Oleomargarine when made in exact imitation in package and color of butter is an ideal counterfeit, furnishing a commodity which can be readily, and in nine cases out of ten with safety, palmed off upon the known but unskilled consumer as butter at butter prices, as only a chemical analysis will, with a degree of certainty necessary in evidence, establish the identity of the substitute.

"The large profit resulting from the sale of oleomargarine as butter in itself furnishes incentive to practise fraud and means of protection in case of detection, and to-day, with the traffic aggregating close to one hundred million pounds a year, the sum collected through the assessment of even a fraction of a cent a pound as a fund for defense is sufficiently large, when judiciously expended through organized channels, to render prosecutions so expensive that in many of the states the courts have scarcely the capacity to handle the offenders, so numerous have they become under the persistent and aggressive solicitation of the wealthy manufacturers.

"The only persons who really profit from the sale of oleomargarine are those who practise deception in its sale, or are the beneficiaries of such deception. The color in the article, conflicting with the state laws, causes the dealer to hesitate to sell it unless the profit is sufficiently large to compensate him for the injury likely to accrue to his business in case of prosecution. Manufacturers openly assure dealers that there is double the profit in the sale of oleomargarine that can be had from the sale of butter—which in itself is evidence that there must be something peculiar about the trade, and they do not hesitate to openly guarantee protection against the efforts of the state to enforce its laws.

"A tax of ten cents a pound, if levied, would be collected upon all oleomargarine colored to resemble butter. The collection of this tax alone would accomplish the result of taking out of the counterfeit article the large profit now held up before the eyes of the retailers as an incentive to commit fraud and violate state laws, and profits on oleomargarine and butter being equalized, each would have a fair chance of sale.

"The policy of prohibiting the coloring of oleomargarine in imitation of butter has the approval of the highest authority in the decision of the United States Supreme Court in Plumley versus Massachusetts, 155th Federal Report, in which such a law as is now in force in thirty-two states was strongly upheld upon the grounds that it was plainly a regulation in the interests of honest dealings."

Justice Harlan, in delivering the opinion of the Supreme Court on the Plumley case, said: "The Constitution of the United States does not secure to any one the privilege of defrauding the public. The deception against which the statute of Massachusetts is aimed is an offense against society; the states are as competent to protect their people against such offenses or wrongs as they are to protect them against crimes or wrongs of more serious character."





## ABOUT RURAL AFFAIRS

**Belgian Hares** A number of our friends have reminded me of my promise to tell something of a visit recently made to a rabbit-ranch. I know that the "Belgian hare craze" has grown and spread rapidly of late, and that it bids fair to infect the whole country and make thousands of our farmers and gardeners take a great interest in an interesting and undoubtedly useful animal. All over the country the common tame rabbit is kept as a pet by young people. The Belgian hare is more interesting as a pet, and of practical usefulness besides. It is just as hardy, just as prolific and as easily raised, and it gives us a very superior meat for our Sunday dinner. The last consideration is more weighty with me than the other. For uses as pets alone I would not care to keep this, nor in fact any other animal. There must be a practical and profitable side to the question to make it worth my while to bother with this sort of stock-keeping. To raise good meat stock it is not even necessary to keep with pure-bred Belgians, and surely not to keep or buy fancy stock at fancy prices. Years ago we raised hundreds of animals, the progeny of common tame rabbits mated with a pure-bred Belgian male. The male, as in breeding up a good cow, should always be thoroughbred. The young stock will be uniformly gray in color, resembling the sire in general appearance; they attain large size and possess as fine meat as the pure Belgian. If any of the males are kept to grow up to full size (which is not desirable nor profitable) they ought to be castrated. Under no condition should they be allowed to breed.

The place to which Mr. Nichols took me to see his hares is a large barn, in which the hares occupy two floors. The rooms are large, well lighted and well ventilated. The entire space is divided off by framework, bottom boards and wire netting (one-and-one-half-inch mesh) into pens about three feet wide and five or six feet long, the rows of pens being separated by alleys. The use of wire netting makes everything open and airy. The animals need no particular protection from cold, only from rains, snow, dampness and filth. Every grown animal has a pen of its own. The breeding does are given a box in which they can make their nest. The board floor of the pen is covered with cut straw or other litter, and this is frequently renewed, say once or twice a week. In every pen I noticed a dish containing oats, a vessel with some drinking-water, a little clover hay and a small cake of cattle-salt. It is quite a sight to see these long stretches of pens and the hundreds, perhaps up to a thousand, of hares. Mr. Nichols is first of all a fancier, and he talks as easily of paying and taking \$25 or \$50 for a fine hare as one would of paying \$50 for a cow. He sees points of superiority in such an animal that I, not being a fancier, do not find unless they are pointed out to me, and even then I may not appreciate them very much. In fact, at first sight I thought I had about as good animals at home as his high-grade and high-priced ones. Some of these hares weigh nearly nine pounds apiece; that is about their maximum weight. Very few Belgian hares that I have had or seen anywhere grow much above seven pounds in weight, no matter what the people who advertise them for sale may say.

**The Feeding Problem** During the past year I have made the experiment of keeping the hares entirely on weeds and garden refuse. I soon discovered, however, that this will not do. I lost most of the young stock before they were two or three months old, and finally the old ones stopped breeding altogether. They need water, and will drink quite a good deal of it; but watery food, such as very succulent vegetables and even roots, must be fed with discretion. Plantains and dandelions, in fact, most of our aromatic or bitter herbs, are all right, but grasses and clovers should be allowed to wilt or dry somewhat before being given to the hares. Cabbage must be given sparingly. Oats are a safe feed, and corn on the ear may be given as a change. Peppermint, spearmint, catnip, etc., come handy as a tonic, and may be fed almost indiscriminately, the animals being very fond of them. Carrots are probably the best among the root crops, and I give a small

portion to the hares daily during the fall and winter. Some peach-tree or cottonwood limbs or bark may also be given as a tonic. Salt must either be given twice a week or so, or better be kept before the hares all the time. I procured some of the cattle-salt, which comes in large chunks, and keep a piece in a little box in each pen for the hares to help themselves to as they may desire.

**Killing Hares For the Table** The proper time to kill a hare for table use is when the animal is about three months old. It will then weigh dressed about two and one half pounds, and makes a really delicious meal. Of course, there are various ways of cooking hares to make them palatable. I will leave that question to the skill of the cook. To see an expert kill and dress hares as I saw it done at Mr. Nichols' establishment looks easy. It takes only a minute or two to get one of the victims ready for the kettle. A short, sharp rap over the head with a little club lays the animal out. The blood-vessels in the neck are then opened with a sharp penknife, letting the blood run freely. Then the skin is quickly removed by tearing it apart from an opening across the back, as squirrels are usually skinned; head and tail go with the hide. The carcass is next suspended by the two hind legs from two separate loops, which keep these legs well spread, and the cleaning is done in a hurry. Mr. Nichols has a fancy way of dressing and putting the carcass into the hands of his customers, and they pay a uniform price of fifty cents apiece. This is what he calls his "meat stock," animals that are not registered, or if so, that do not show fancy points. Some people have yet a prejudice against the meat of tame rabbits. I used to have it, but believe the prejudice will wear away as it did with me. The meat is really excellent.

**Fecundity of Hares** Much has been said about the fecundity of these animals, but hardly too much. The average number in a litter is probably from six to eight. Frequently, however, there are ten, twelve, and even more of the little things. It is unfortunate for some, if not all, of them if there are that many. The old doe cannot properly nurse more than eight, although they do occasionally bring up more. Six are better than ten or twelve, and it is always advisable to destroy all above eight. How often to breed them is another question. The period of gestation is thirty days. I used to let the young get three or four weeks old before mating the old doe again, but Mr. Nichols tells me that he only waits a day or less, perhaps only eight or ten hours after the young are born, before he mates the doe again. He considers this by far the safest way. It gives a litter every month in the year, and if the average throw is six, and they all do well, there would be an increase of seventy or more from one doe in the course of a year. Such an increase may actually and frequently happen. It will not happen, however, unless the hares are handled right and all the conditions are favorable.

**Improving Poor Soil** One of our friends who has had only two years' experience in farming writes me that he wishes to improve a piece of about five acres which adjoins the place he has rented for a period of five years. The soil is rather poor, being clay or clay loam; location, Montgomery county, Pennsylvania. The proposition is to sow clover, take off the first crop and turn the second under. Probably this will be the best course to take. With a five years' lease one has a chance to get full returns for any application or course of treatment calculated to make the soil productive. Prepare the land well in early spring; sow one hundred pounds or more of muriate of potash and two hundred pounds or more of superphosphate (acid phosphate or dissolved bone) an acre. Then make a thin sowing of oats or other grain, just enough to provide a little shade for the clover, and sow the clover-seed. By fall there will be a big growth of clover on that field, and it should not be pastured or cut. The year following the field is in shape to give a good crop of clover hay, which should be cut in good season; that is, just as soon as the clover is in bloom. Then

there will be a heavy second crop, and this may be either plowed under in the fall or be cut and left on the ground to decay and be plowed under in the spring.

With additional light applications of mineral plant-foods such as already mentioned the chances of good crops of potatoes, corn or grains of any kind for the next three years of the lease are very good. In many cases we might even plow the clover down the first fall, or in the spring following, and grow a good crop of potatoes or corn. But if I did not want to lose the use of the land for such crops longer than one season I think I would try the Southern cow-pea by planting it as soon as the ground has become warm in the spring, sowing the seed either broadcast or with a grain-drill.

T. GREINER.

### SALIENT FARM NOTES

**Thorough Work at the Right Time** "I don't have to urge the boys on in the spring," said a successful farmer, "but rather have to hold them back. It is difficult to make an energetic young man wait. When the skies are blue and the wind blows softly from the south the young man is impatient to begin plowing and sowing, even if the soil does turn a little heavy. But I tell the boys to wait a little longer—wait until the soil crumbles as it falls from the plowshare, then go in and do your utmost. One swallow does not make a summer, neither does one beautiful spring day fit the soil for the plow. If we plow too early, before the soil is ready, our labor is vain, because the soil will bake or pack if tilled too soon, and then the only remedy is to replot. I tell the boys we would better be a little later than our neighbors than to have to do our work twice. Well done once is better than half done twice."

A man who always has one of the best gardens in this locality never turns a furrow or plants a seed until the soil is in the condition that suits him—dry enough to crumble and work smooth with the rake. Many a time I have seen him quietly sitting on his porch while his neighbors were busy plowing, digging and planting. "My soil is not yet quite ripe," he would say, when asked why he was not gardening. When his soil was ready the work was done in a remarkably short time. Seeds were planted and plants set out, and almost before his neighbors were aware of it his garden was far ahead of theirs. His soil teemed with fertility, and not a weed was allowed to rob it of an atom. "I am slow to begin," he has often said to me, "but when I do begin I accomplish something." He starts his earliest radishes and lettuce under light frames covered with glass. The seeds are sown in beds the size of these frames, the frames placed over them, and as soon as the plants appear they are removed and the beds used for other plants or seed-beds. It is surprising how quickly seeds germinate under these frames after the soil has become slightly warmed. And it is still more remarkable how rapidly the plants grow in a soil that is filled with fertility when that soil is in the best mechanical condition. We smile as we read in seed-catalogues of "twenty-day radishes," "early sunrise lettuce," "very previous beets," etc., but I have seen vegetables in this man's garden attain to good table size so quickly that one could scarcely believe it. The secret of this rapid growth was not planting in a moon or star sign, but planting in a very fertile soil that was in perfect mechanical condition and when the season was far enough advanced to be "just right."

It is the same with field crops, especially corn. The masterpiece in corn-growing is proper preparation of the soil for the seed. At a farmers' institute last winter one of the best corn-growers in this state said: "The more thorough the preparation of the soil the surer and larger the crop. I work my corn-land until the ordinary farmer would say it is in perfect condition, then I work it twice more. I plow when the soil will crumble, and pulverize with a steel-toothed harrow until it is as fine and smooth as a field that is in perfect condition for winter wheat, and then I plant. In such a seed-bed the planter places the grain at a uniform depth, and covers it with mellow soil. Every grain grows and the stand is a perfect one, and cultivation is comparatively easy, while the plants make a good start and grow rapidly." A farmer in the audience asked him how he managed in a wet season. "In the twenty-two years I have farmed," he replied, "we have had but two in which I was unable to practise my method. The first of those two I grew only ten acres, but

the second I raised twenty-five acres. The planting was finished the sixteenth of June; the variety planted was a small, early variety, and I husked a little over thirty-seven bushels an acre of sound, matured corn. I paid two dollars a bushel for the seed, and express charges about two hundred miles. I was the only man in my neighborhood that husked ripe corn that fall."

This man advised farmers to not be afraid of paying a good price for sound, ripe seed. This is the rock many a farmer has been wrecked on. He would better pay three dollars a bushel for sound seed than to accept unsound seed as a gift. Only a few days ago a very successful farmer told me that he had procured three bushels of an improved variety of corn, tested its germinating qualities, and found that about ninety-eight per cent of it would grow, and he intends to prepare the twenty acres he will plant in the best manner, and plant with the hoe. He said the best corn he raised last year was four acres he had planted with the hoe; and as he had paid a high price for his seed this year, he is determined to see that it goes into the ground in the best manner, and that every hill has four grains. I mentioned this to an old corn-grower, and he said the man is right, and that he would do the same thing under like circumstances. He further said that he always harrowed his land over three times before planting, and he is satisfied that the best and most effective cultivation that could be given the crop is that which is given before the seed is planted. Thorough preparation of the seed-bed is more than half the cultivation of the crop. If the farmer is unable to give it this thorough preparation it is because he is trying to farm more land than he can.

"Hogs are on the boom!" exclaimed a farmer, jubilantly, as he passed me with a big load. Only a few weeks ago many farmers were complaining that hogs were not paying for the food they ate at the prices then being paid. How many of them are groaning because they disposed of the bulk of their stock as "light weights"—one hundred and fifty to one hundred and seventy-five pounds—before the rise in prices. If they had held on until their stock had reached two hundred and thirty to two hundred and fifty pounds, the most profitable weight to market hogs, they would have come in on the rising tide. When a farmer is short of feed it is better to sell the stock light than to buy feed and risk great loss. But when he has the feed it is best to hold stock until "ripe" before he sells, unless there is danger of loss from disease or he is not situated to keep hogs comfortable when cold weather comes on. The rise in prices seems to have been caused by a somewhat short crop of hogs and the extraordinary demand for pork products both at home and abroad. Every soldier knows how good a nice slice of bacon fried on a shovel is to a hungry man in the field. Thousands on thousands of pounds have gone that route, and the demand is increasing. Little wonder that "hogs are on the boom."

As everything in the hog line that can be spared, and much that ought not to be spared, will go to market, it will be a good idea to look sharply after the coming crop. Nothing is easier than to lose a whole litter of pigs by a little neglect. It is generally well understood that a farrowing sow should be inclosed in a pen by herself, and most farmers have the necessary arrangements made. She should have just a little clean straw to make a nest from; hot enough to make a high bank around her, but a low ridge that little pigs can easily climb over. Her food should be somewhat laxative and cooling, no corn or corn-meal being in it, for at least two weeks before farrowing, and she should have constantly at hand all the pure water she desires. The object in feeding cooling and laxative foods is to reduce the heat in her system, make her rest quietly and farrow easily. Most farmers rely on a thick slop or mush made of equal parts of wheat-bran, middlings and oatmeal, with finely chopped roots. FRED GRUNDY.

### NOWADAYS

If now upon a leaf there falls a spore,  
Which germinates and grows and finds a pore,  
The careful farmer starts to spend his ore.

He buys a pump with which to force a spray  
To kill the thing. His father used to pray  
Before our modern practice shed its ray.

The spray-pump is the thrifty farmer's friend;  
Though cash and he reluctantly must rend,  
Yet they will meet again at season's end.

M. G. KAINS.



OUR FARM

FARM THEORY AND PRACTICE

**HARROWS AND HARROWING.**—The man who has a living to make from the ground is awakening to the advantages of thorough stirring and fining of the soil. The old-fashioned square farm garden, with its high-pailing fence and narrow gate, had one advantage over the modern garden whenever its inconvenience led the owner to use a spade rather than a plow for breaking it up in the spring. It got a thorough stirring—one more thorough by far than is ordinarily given by modern implements drawn by horse-power. It is not that the plows and harrows of today cannot prepare a soil properly, but the inversion of the soil by the plow and the smoothing of the surface by a harrow deceive us in regard to the thoroughness of the preparation, and hurried planting is done before the ground is really ready for the seed. But we are learning to put more work on the land than was thought necessary some years ago, experience proving that it pays, and to meet our wants there are harrows of all styles and kinds, attention of late being given especially to those that do the work with something of the thoroughness of the spade in the old garden. It is mixing of the soil and airing of the particles that is needed first. The plow inverts or sets the furrow-slice upon edge, but it does little grinding and mixing. The smoothing-harrow on these furrows makes a pretty surface, but it does not make a good seed-bed in any except very loose and porous soils that crumble finely at the touch and admit air without stirring. The clay, the clayey loam and other compact soils require thorough stirring and mixing, no matter how smooth the surface may be.

\*\*\*

**HARROWING THE UNDER SIDE.**—I have said that there are harrows of all styles, and yet much soil goes into the bottom of the furrow that is never stirred. Compact pieces of soil find a resting-place in the bottom of the furrow, and are not aired and ground up so that their tough plant-food can be made available. The man who uses a big disk or spading harrow after the plow may think that he is doing thorough work, but if he will dig down into the ground where the plow has gone seven or eight inches deep he will find about four inches of compact soil untouched; if not four, then three at least. I should say that most plowed fields do not have over half the depth of the plowed soil stirred, mixed and fined. The under side of the slice cannot be

is pretty well harrowed. Not only that, but the furrow-slice crumbles much better in the plowing, and less work is needed after the plow. The added expense is not so great as it would appear on this account. But even if the harrowing before the plow, fining the ground that would go out of reach of the harrow, were wholly additional expense it would not matter if there were profit from the work, and we are surer of profit from thorough fining of the seed-bed than we are from any other farm-work that we engage in as a matter of course. Mixing and fining means more fertility and moisture.

\*\*\*

**VARIOUS KINDS OF HARROWS.**—Harrows belong to two distinct classes, those that act like a plow, loosening and tearing into pieces, and those that slice and firm the soil. For a spring crop like corn or potatoes the first action is the most essential. Rains will usually firm the soil sufficiently, and the main point is to secure mixing and airing. After that has been done the smoothing-harrow does good, as also does the plank-float. But I emphasize that the loosening and tearing into pieces is the more important of the two in case of these crops, while we are apt to depend upon the surface appearance secured by the second class of harrows.

I like the disk-harrow. The usual objection to it is that it makes heavy draft. When that is due solely to the huge amount of stirring it is doing the fault is a good one. A more serious objection is that dirt will often get into the boxing and add to draft without doing aught but harm. It seems difficult to make a harrow of this sort that will not take dirt at the bearings, and close watch must be kept. Another objection to many makes is that when disks are set to run deep there is weight at the end of the pole, sinking the draft on the horses' shoulders. But that is a wholly unnecessary fault in construction that all manufacturers could obviate by use of an independent pole that would serve only for guidance, the draft being attached directly to the frame. For some kinds of work the "in-throw" is best, and for other work the "out-throw" is desirable. Everything considered, I prefer the "out-throw," but believe that the "in-throw" is in more general use and popular.

The spring-tooth harrow does grand work in tearing and mixing, but it cannot be run as deep as a disk where a sod or trash has been buried. Where there is nothing in the way the spring-tooth does nearly perfect work, and I like especially its action in bringing clods to the surface to be pulverized with a plank drag.

Harrows of the "Acme" type both pulverize and smooth the surface. They should not be regarded as competitors of the disk, but fit into use after the disk. Such a harrow is superior to the ordinary smoothing-harrows, because it grinds and pulverizes more effectually. But a modern spike-tooth harrow is capable of doing lots of good work. The teeth can be set at the needed

A CONVENIENT AND INEXPENSIVE SHEEP-BARN

In arranging for the construction of a barn and sheds for sheep due consideration should be given to the lay of the land. Probably the ideal location for such a structure is in a side-hill, where the slope is sufficient to carry off surplus water, but not sufficient to make any great expense in the way of excavating. Next to the selection of a proper location is the construction and arrangement of the building, and the yard as well, for while sheep will stand considerable cold without injury, dampness is not only injurious, but often fatal. It follows, therefore, that the builder must keep in

into a walk-way (A) wide enough to permit barrels to be rolled in and bins (B B) at one side and end. A door (D) opens directly out at the side, and another into the yard. The bins for roots are five feet wide. It will be noticed that the shed protects the care-taker from the weather in passing through the rear door. At V is a window large enough to pass a bushel basket of roots through to a shelf built directly over the feeding-racks. This shelf will be found a great convenience, as it is high enough to be out of the reach of the sheep, and obviates the necessity of carrying the roots. The basket may be set on the shelf, the feeder pass around to the feeding-racks and easily lift

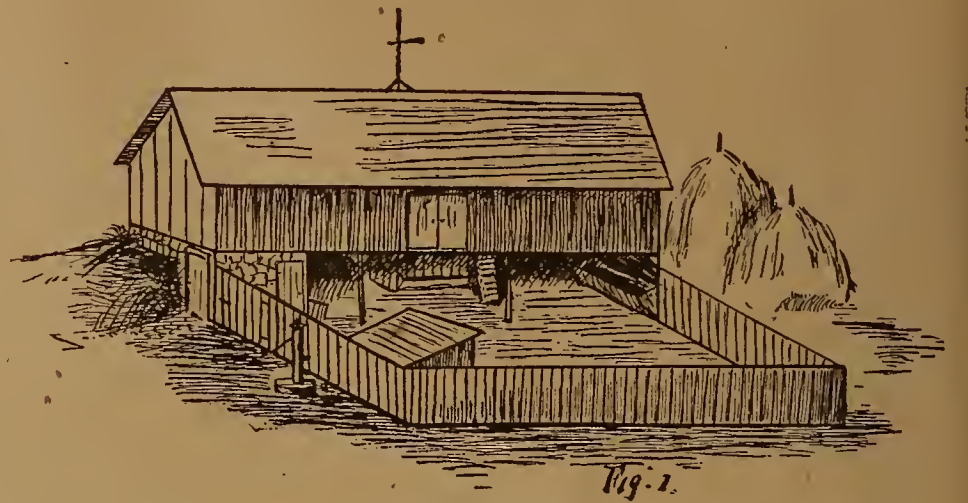

mind at all times the importance of good drainage. This is easily obtained if the sheep-barn is built in a side-hill, but in the absence of such a location the same plan as indicated and illustrated may be followed out, and the same conditions obtained at the expense of some excavating. Select the highest available location, grading so that the surface under the shed and at least a portion of the yard will be so sloping that water cannot stand on it. It will certainly pay to start right, and then the after-expense, so far as the grounds are concerned, will consist only in filling in from time to time any woru or low spots. The soil should be as sandy as possible, avoiding gravel, which is a source of considerable trouble with foot or hoof diseases. The shed should be made comfortable, and the earth floor should be kept well covered with litter of some kind, for the double purpose of giving comfort to the sheep and the absorption of the liquid excrements. The yard should be cleaned frequently and kept well covered with litter during the period when the sheep are confined.

This window or opening is covered with a sliding door which may be moved from either side. At W an outside window with glass admits light into the root-cellar. The feeding-racks at C are about two feet wide, with slats placed close enough to prevent the animals from getting their heads through. At N N two pens, each eight by seven feet, with feed-rack in front, are built for the accommodation of ewes and their young, which may be required to be separated from the rest of the flock for a few days, as is frequently necessary.

The yard is twenty-five by forty feet, with a convenient shed built in one corner at S, fitted with a smooth board floor, and with shelves for the accommodation of the various tools, medicine, etc., required in the care of the flock and the shed. At shearing-time this shed will be found especially convenient, although it may be omitted from the plan if the added expense is considered too great. In the absence of any other system of supplying water a well should be located at L, so that a liberal supply of water may be conveniently had. On the main floor of the barn (see Fig. 3) the space in the center is a walk-way, with doors (O O) at front and rear. This walk is made eight feet wide, for convenience in filling the mows with hay, straw or fodder. K indicates a chute, through which fodder is thrown down into the shed for distribution into racks. A small grainery (G) is eight by sixteen feet, with bins five feet wide at sides and one end divided into compartments of convenient sizes for the several grains used. At X is a wooden pipe or chute twelve inches square running down into the basement (see X in Fig. 2) into a strong box built at the end of the feeding-rack. This box is fastened with a hooked cover. This chute will be found a great convenience in feeding, the required amount of grain being measured out in the barn, run down the chute and distributed

into the troughs. By the plan of this chute, and the one for the fodder, both grain and fodder are placed where they are wanted, saving much time and labor in the handling. At I steps are built alongside the chute by cutting a trap-door in the floor, thus giving an easy and convenient passage to the basement or shed, especially to be appreciated in cold and stormy weather. The yard should be surrounded by a tight board fence, with a strand of barbed wire fastened along its top edge to keep out intruding dogs if there is danger from that source.

The plan as described and illustrated has many advantages which will be apparent to the sheep-grower. Economy of space is carefully figured, as well as economy in steps, which is quite essential in our more modern farm-work, and especially so when the work all falls upon the shoulders of one man. By the disposition of the hay and other fodder additional warmth is given to the shed below, a point that is well worth considering.

GEO. R. KNAPP.

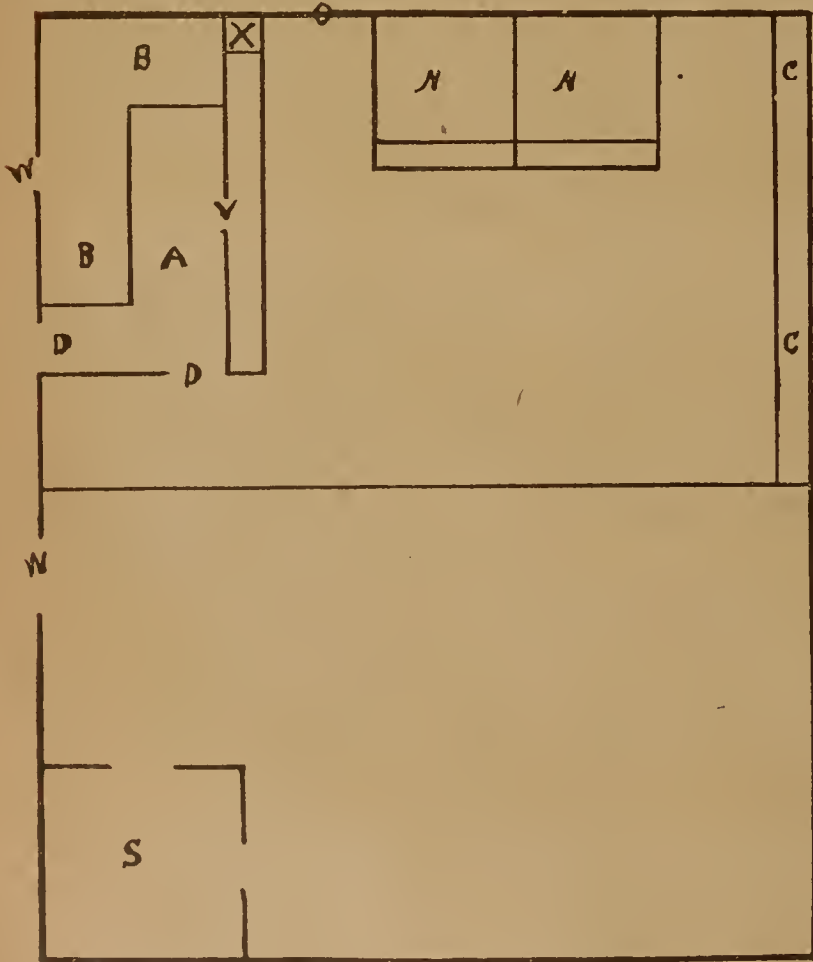

Fig. 2

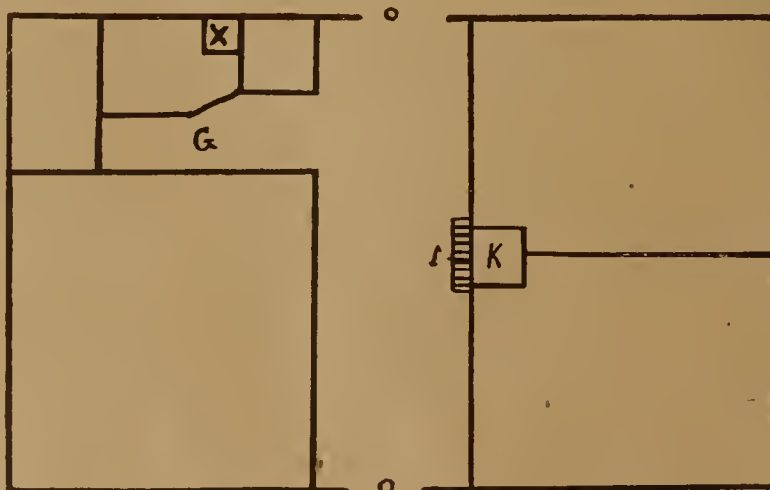

Fig. 3

fined after the plowing is done. A few thorough farmers are learning to stir this part of the ground before it is turned by the plow, when the soil will permit. A spading or disk harrow properly weighted is run on the surface before the breaking-plow, and when the plowing is finished the under side

angle, and the harrow covers ground rapidly on account of the width, fining the surface and killing the weeds that are starting under the surface. There should be good breadth and weight. Such a harrow holds its course better than a narrow and light one, not sliding around on hard or solid places. DAVID.

in Fig. 2), is built into the hill like a cellar wall, the side walls being constructed in the same manner. In one corner of the basement or cellar thus formed is partitioned off a space which forms a separate cellar for the storing of root crops. This cellar or space is ten feet wide by twenty feet deep, divided



## NOTES FROM GARDEN AND FIELD

**CANNING-FACORIES.**—My description of the canning-factory plant in Fairport has brought me a good many inquiries about the advisability of starting such plants elsewhere, and especially about the capital required, about manufacturers of canning-house machinery, etc. I just noticed in "Country Gentlemen" an editorial reply to a similar question, and think this reply hits the nail so squarely on the head that a quotation from it may help my inquiring friends out of a dilemma, and possibly save them taking wrong and costly steps. "It would be impossible to give figures on building and equipment for a canning-factory. We can hardly see how any local market could be made a paying enterprise for a factory. A canning-factory, like everything else at present, is made profitable only when conducted on broad plans and in a large way. Buyers as a rule wish to purchase their stock where they can procure almost everything wanted in their markets; hence the importance of being in position to can everything produced, from rhubarb up to and ending with apples. Beans, corn, tomatoes, berries of all sorts, cherries, plums, quinces, indeed, everything that can be thought of, is wanted, including pumpkins, squash, peas, etc. Many small factories are being started which we much fear will not find the business a paying one. The outlay of cash is large; tin, sugar, raw material, labor and all such requirements must be cash down. Then sales are made on from three to six months' time; hence the importance of a large available capital. A plant we know of has sixty thousand dollars invested, and yet is a large borrower every year from the banks. A working capital of one hundred thousand dollars would be none too large, to say nothing of that required in the way of buildings, machinery and necessary appliances." This is a whole flood of cold water on the enterprising spirit of would-be small operators, but it may save somebody from buying a costly elephant.

\*\*\*

**GIBRALTAR ONION.**—I have made almost a complete failure with my first sowing of the Gibraltar onion in the greenhouse. The Prizetakers standing side by side with them make a fine show at this time, although planted a week later. It seems to me that the Gibraltar seed this year is lacking in vitality, and I wrote to Mr. Burpee about it. He tells me that this onion is a very shy seeder, and that in all these years he has never been able to secure a good crop of the seed, which also accounts for the fact that he has not given it the prominence in his catalogue which it seems to deserve. Well, I will have to depend a little more on the Prizetaker for awhile. I am also trying some imported seed of the true Spanish onion.

\*\*\*

**SOME CURRANT NOTES.**—I am very fond of currants, and especially of currant-juice. In my individual case the currant acid seems to possess decided medicinal properties, and I verily believe that it will act as a germicide. Be that as it may, I find this currant-juice quite palatable, and for years I have been putting up a good many cans every summer. I have been growing a good portion, but not as many as I wanted to do up, and while the price was down to four or five cents a quart it seemed no hardship to have to buy a portion of my own needs in this line. But currants are an easy crop to raise, and I do not propose to continue buying even a small portion, especially when prices seem to have an upward tendency. At the last meeting of the Western New York Horticultural Society the outlook for commercial currant culture came to a discussion, and our leading growers feel confident of an increased demand at increased prices for the fruit. New York state laws now forbid the substitution of artificial products for fruits in making jellies, etc., for sale. Consequently, the jelly manufacturers will have to return to old-fashioned ways of manufacture; that is, to the practice of using real fruit and fruit-juices for their raw materials. In short, I have decided to plant a few hundred currant-bushes more this spring, and the only question is what kind or kinds to select. Of course, white sorts are not much in demand in market, and yet they are among our very best sorts for the table, being sweeter and less seedy. I want at least a portion of my currants for home use of some good white sort. Mr. Willard (and he knows what he is talking about, and honest

enough to tell the truth) names White Imperial as the best for table use; and this is the one I have selected. The Wilder is a new red sort which I have not yet tried. But when Willard, Barns, Hooker, Prof. Beach and other experienced growers unite in praising the Wilder as the best red currant for commercial purposes I have to believe it. The Wilder plants can be bought at the same price as other currants, so I have selected this variety as my red one to plant this spring, and I plant three of this to one of the other. Prof. Beach, of the New York state experiment station, pronounced the Wilder a good currant and a late keeper; the Imperial good for dessert. Mr. Barns said the Wilder is an upright, strong grower, in color like Fay's, and holds out longer than any other currant. This last is quite a consideration with me. I like the dead-ripe currants for dessert and to eat out of hand late in the season. They are then very sweet and agreeable to my taste.

\*\*\*

**TESTING SEEDS.**—I have not often thought it necessary to test seeds freshly purchased from reliable seedsmen. The old established seed-houses that are in the business to stay cannot afford to send out seeds that do not grow. Of course, mistakes are liable to happen even with them; but such firms are usually very careful. In some cases we do not have the time to test seeds: Thus it was with a lot of Gibraltar onion, an imported variety, which I received last December, and immediately on receipt sowed in the greenhouse, only to find that it was either old seed (the new not yet having arrived) or at any rate seed of very low power of germination. Whenever we have seeds left over from the year before, or obtained from a suspicious source, we should always try to test them before risking a crop. This, too, is easily enough done. Take a few pieces of flannel, place two or three thicknesses into a plate or saucer, scatter fifty or one hundred seeds over the surface, then cover with another couple of thicknesses of flannel. One end of the flannel pieces may extend over the edge of the plate or saucer, and be inserted into a cupful of warm water standing by the side of the plate. Keep this tester in a warm place, and examine it from day to day. The flannel should never be allowed to become dry. The water is gradually taken up from the cup by capillary action, keeping the whole flannel moist. When the seeds sprout take them out and count them, thus ascertaining the percentage of good seeds. Of course, we often have serviceable seeds of low germinating power. If I have an especially good kind of cabbage or cauliflower or tomato, etc., I would not hesitate to use the seed even if only fifty per cent or less of it would grow. The fifty plants might give better results than one hundred plants of another lot of seeds every kernel of which grows promptly.

T. GREINER.

### INQUIRIES ANSWERED

BY T. GREINER

**Rhubarb From Seed.**—G. V. T., Spokane, Wash., asks whether any special treatment is necessary for propagating rhubarb from the seed.

**REPLY:**—It is not. Rhubarb-seed sprouts freely, and the plants are easily managed. Prepare the land in the same way as you would for cabbage-plants, radishes, carrots, turnips, onions or any other close-planted vegetables; then sow seed in drills, say a foot apart, rather thinly, and cover lightly. Thin the plants to stand three or four inches apart, and in the fall or spring following set into the permanent bed, which should be in deep, warm, well-drained soil. Give the plants a good dressing of rich compost every year.

**Corn and Fertilizers.**—A. B. L., Retz, Va., writes: "I have a piece of land that has been cropped with peas two years. I cut the hay from it each year. I want to put corn in the same land this year with South Carolina rock and kainit. Please tell me what portion of each to put to an acre. I also have about thirty bushels of refuse salt that meat has been packed in, and I would like to know if I can use it to advantage on land; if so, how much to an acre, or how is the best way to use it? Could it be used in the barn-yard with manure?"

**REPLY:**—How much of these fertilizers to apply to the acre depends largely on the land itself. Southern cow-peas are a good crop for the land, and probably leave the land better supplied with humus and nitrogen than it was before, and yet I cannot believe this is a very material improvement as long as the pea-vines were all removed from the land. If the soil was rather poor to start with you will need more superphosphate and kainit, and less if the soil was in fairly good condition already. Corn, of course, to make a big crop requires quite a good deal of plant-food. Try about two hundred and fifty to three hundred and fifty pounds each of the two ingredients an acre. This can be done at an expense of from \$3.50 to \$4.50 an acre. Use less if soil was good already. You can sow the refuse salt on your land anywhere at the rate of a bushel to a harrel an acre, or heavier for onions, cabbages, celery, asparagus.

## ORCHARD AND SMALL FRUITS

CONDUCTED BY SAMUEL B. GREEN

### THE STRAWBERRY

**LOCATION AND SOIL.**—The strawberry crop is generally most satisfactory when grown on a northern slope, as it is then not exposed to the drying southerly winds, which in exposed locations occasionally so dry out the land that the crop is seriously lessened; also as the plants start latest on north slopes the blossoms are not liable to be injured by the late spring frosts, which sometimes cause serious injury to plants that start early. Some growers, however, are very successful in growing them on southerly slopes or on level land. In a general way any land or location that is good enough for a crop of corn will do admirably for strawberries, but strawberries should never be planted on sod-land on account of the liability of its being infested with cutworms or with the white grub, which feeds on the roots of the plants.

**MANURE AND PREPARATION OF THE LAND.**—The strawberry is a gross feeder and needs plenty of plant-food in the soil. The best fertilizer is barn-yard manure that is partially rotted, but it should not be plowed in very deep. It is generally best to plow the land deep in autumn, apply the manure in winter or in spring, and then plow the manure under very shallow as soon as may be thereafter. The land should then be thoroughly dragged and smoothed, when it is ready for the plants. When so prepared the land has a loose surface bed in which to place the plants, while underneath it the soil is so firm as to retain the moisture and yet it is open enough so that the young roots can push into it.

**TIME OF PLANTING.**—Practically there is only one time to plant, and that is in the spring. It is occasionally recommended to plant in August. It may be all right to do so in case there is no strawberry-bed in the home garden and there is considerable moisture in the ground so the plants will live without too much care, but in ordinary seasons here the results from setting the plants at this time are very uncertain and do not warrant the planting of them on a large scale. If it is decided to set a bed for the home garden in August or September the plants may be well-rooted layers from some bed near by, or if obtained from a distance they should have been potted and be well rooted in the pots. The potted plants cost more, but are much surer to grow than layers. The growers of strawberries for profit in the Northern states always plant in the spring. The earlier the plants can be set the longer the season for them to grow, and the cool, moist weather of early spring seems to favor the formation of roots, but they may be set as late as the first of June with fair prospect of success. However, if the land is very dry at planting-time it is best not to plant until after a rain, even if waiting for it may delay the planting considerably. It is poor practice to set out strawberry-plants for profit in dry soil and try to keep them growing by watering, as so much water and attention are required that the operation will be a losing one unless special irrigation is provided.

If plants are received when the land is very dry it is the custom of the best growers to open the bundles, shake out the plants, and dip the roots into a clay-loam mud and "heel them in" close together, putting a little soil between the plants. When thus treated they may be easily watered, and will commence to grow and be ready to set out in the field or garden as soon as a favorable time offers. If the space where the plants are heeled in is surrounded by a board fence or other wind-break a few feet high it will aid much in preventing the drying action of the wind.

Plants that have been some time in transit are very apt to look white and weak when received, and are almost sure to die if at once set in the full sunshine. They should be heeled in and partially shaded until they assume their normal color.

**PLANTING.**—All large growers pursue very nearly the following plan: After the land is prepared in the spring it is marked out with a corn-marker, four feet one way and two feet the other, and the plants are set at the intersections. The horse-cultivator is run both ways until the plants commence to make runners rapidly (about the middle of July), when it is run only in the four-foot intervals. The runners are then pushed together, forming a bed or matted row, which by autumn will be eighteen inches wide. The ground between the rows should be worked as often as once in ten days throughout the growing season up to the first of

September, after which cultivation should cease for the year. Keep the soil loose, and be sure the bed is free from weeds on the approach of winter. For some varieties two feet apart in the row may leave larger gaps than the runners can fill, but almost any of our commercial kinds will easily fill up even larger vacancies. Such varieties as the Crescent will easily fill up intervals of three feet in rich soil. The runners should stand about six inches apart in the bed by the first of September, and should be thinned out if much thicker.

**TRIMMING AND SETTING THE PLANTS.**—The plants when dug should have all the dead leaves, pieces of runners and blossoms trimmed off, and if there is a considerable growth of leaves they should be cut off. All flowers that appear the first year should be taken off. If the roots are large they are not readily planted, and it is customary to shorten them to about three inches. If a great mop of roots is planted in a bunch a part of them is very apt to rot. Perhaps as good a way as any to set the plants is with a spade. This requires two persons, generally a man and a boy, to do the work rapidly. After the land is marked out the man places the spade with the back side away from him, presses it about six inches into the moist earth, moves it from him and lifts it out. The boy takes up a plant, separates the roots, and puts them in the hole. The man puts the spade in the ground about four inches nearer him than he had it before and presses the soil against the plant. The boy finishes the operation by firming the plant in the soil with his hands. As soon as the planting is done the cultivator should be started to loosen up the soil. Great care should be taken to keep the plants from getting dry when planting them out.

**WINTER PROTECTION.**—Under whatever system the strawberry may be grown, it is benefited by being protected in winter by a mulch of sufficient thickness to prevent frequent freezing and thawing, which is very injurious to the plants. Of course, a covering of snow will answer the purpose, but it is not safe to trust to it. This mulch should consist of marsh-hay, corn-stalks, straw, boughs or any litter that does not lie too close and is free from weed-seeds. It should be put on deep enough to cover the plants. Generally three inches is sufficient, but for Nebraska, Dakota, Minnesota and northern Iowa it is desirable to cover deeper, especially in severe winters when there is little snowfall. It is a good plan to put on a thin covering of mulch before the ground freezes hard and add the rest later. Such care in covering is not necessary in more favored sections. In the spring the mulch should be drawn from over the plants into the intervals between the rows, where it will act to preserve the moisture during dry weather and to keep the fruit clean.

**AVOIDING FROSTS.**—It sometimes happens that blossoms which appear about the middle of May, and are quite susceptible to frosts, are seriously injured of cold nights. They may often be successfully protected when in this critical condition by taking the mulching from the rows and throwing it back again on the plants for a few days, or until the danger from frost is past. If the winter mulch is left on as late as it is safe to do so, which is until the new growth starts strongly, it will serve to retard the plants and they will not come into blossom until a week or so later than they otherwise would were the mulch removed early in the spring and not until the great danger of frost is past. This latter method makes the crop late, but is a good plan to follow in some sections. An ordinary frost seldom destroys the stamens, its damage being confined to the pistils; therefore the center or berry part of the flower turns black.

[TO BE CONTINUED]

2

### INQUIRIES ANSWERED

**Red-cedar Seedlings.**—S. E. W., Bradshaw, Neb. I have been very successful in handling red-cedar seed as follows: Procure the seed in the fall or spring. Soak in strong lye over night. Rub against a fine sieve to take off the flesh. Sow in a bed in light soil, and cover with about three inches of hay. The following year early in the spring it will start and make a good growth. Treated in this way I think it a very certain crop. I know of no way of treating it so that it will start the first year.

**Catalpa.**—A. J. T., Presque Isle, Maine. *Catalpa speciosa* is not adapted to the extreme Northern states. It is doubtful if there is a perfectly sound specimen of it twenty years old north of central Iowa in the Mississippi valley, and I doubt very much about it being sufficiently hardy for northern Maine. The seed may be obtained from any of the larger seed-dealers at seventy-five cents a pound, and seedlings cost about \$3 a thousand. Where it is hardy it is one of the most profitable trees to grow for wood.



TRANSPLANTING—USEFUL IMPLEMENTS

**T**HE market-gardener who transplants many thousand small plants, as celery, onions, cabbages and cauliflowers, and must work on his knees for several days at a time, finds the work very tiresome. In my market-garden I begin in the early spring to transplant strawberries, then follow with onions, early cabbages, cauliflowers and celery, and this work of transplanting is not finished until in July. In some years, with only a boy to help me, I have transplanted nearly one hundred thousand plants. This work is sometimes very unpleasant, for it is sometimes necessary to work when the ground is wet and cold, and again the work must go on even during a rain to get the plants out in good time. After doing this kind of work until I was losing the use of my knees and impairing my health I began to study how I could use implements to do a part of the work. Sometimes I was obliged to transplant in the dry weather; then I first marked the row for the plants, applied water along the rows with a watering-pot, and then made the holes by hand with the dibber for setting the plants. I now have an implement that marks two rows, makes the holes for the plants, and applies the water as fast as a person can walk.

In my first attempt to make an implement of this kind I used a wheel with handles attached in the same way as for the wheelbarrow. Around the outside of the wheel pegs two inches long were placed six inches apart, and the wheel was weighted so it would drive them into the ground as it revolved. I used this for some time, until it occurred to me that I could place a bucket of water on the frame back of the wheel, and attach a piece of hose to the bottom that would carry a small stream of water to the ground and over the line of holes that the wheel had made. My next improvement was to use a two-wheel cart made very much like the common push-carts. A water-box was placed on the cart between the wheels, and handles were attached to the front and rear of the cart, so that two men could run it. I had found that in using pegs on the wheels to make holes in dry soil some of the soil would fall back in the hole, and partly fill it. This difficulty was largely overcome by using three-cornered blocks in their place. These blocks are one inch thick, two inches high and three inches apart. These are nailed on the wheels three inches apart for celery-plants, and hoop-iron one inch wide is nailed over them around the outside of the wheels. Back of the wheels are placed cleaners that scrape off the earth that will sometimes stick to the wheel. Two pieces of hose are attached to the bottom of the water-box on each side, the lower ends being fastened close to the ground back of the wheels, but there is a coil in the end of the hose to break the force of the stream to prevent it from washing soil into the depressions made by the rims of the wheels.

The size of the stream of water is regulated by cut-offs placed inside of the water-box. The length of the axles are two and one half feet. This makes the spaces between the rows about right for celery and cabbage. A marker is used to gage the mark for the next row, so that after one row has been made with a line all the others will be straight.

I think from the description I have given that any carpenter can make the implement at the expense of only a few dollars. Last year I used this tool in setting about fifty thousand celery-plants, and I think it saved me half the work. The plant-bed should be very finely pulverized and leveled with a light roller or plank-drag. All the obstructions should be removed to have the tool do good work. This is not an objection to its use, for the ground must be very free from sods and stone to use the wheel-hoes that are used in cultivating the crop. The tool must be used when the soil is not so wet that it will stick to it. One need not wait for a rain to wet the ground for setting plants, and I like the plan much better of doing the work in pleasant weather. Before I begin to set plants I lay the irrigating-pipes over the field, and I can attach a hose to these at different places and fill the water-box. This box holds about fifteen gallons. The rims of the wheels are three inches wide, and the weight of the water does not depress the soil too much, even if it is very mellow. This tool may be used for making holes for onion sets by putting a rim around the wheels, notched two inches apart, or for transplanting the small onion-plants from the hotbed. It can also be used for cabbage-plants by having the pegs or blocks on the wheels eighteen inches apart, and I think it would be useful in setting

tobacco-plants. My way of doing it is to have two persons follow and set the plants as fast as it prepares the ground for them, and before the water dries out. The plants are set very rapidly in the holes that are all made just the right distance apart, and after the plant is set a little dry soil is drawn around the plant to prevent the water from evaporating too soon.

For close work in the garden, where the rows are less than two and one half feet apart, only one wheel is to be preferred, which is placed in a frame like a wheelbarrow. This is convenient for marking the rows and making the holes for onion sets or other bulbs, also for the onion-plants and for the celery-plants that are planted with narrow spaces between the rows, according to the plan of the new celery culture. For covering bulbs after they had been dropped I have used coverers attached to the Planet Jr. combined seeder and wheel-hoe. In this connection I will say that I have nearly all the Planet Jr. garden-tools. The new hill-droppers are very convenient for planting cabbage-seed in the field in the hills where the cabbages are to grow. The attachments to the twelve-tooth horse garden cultivator are very convenient. The pulverizer which can be attached to the rear of the cultivator is useful for preparing the ground for the seed-drill. The irrigating furrower I use for furrowing for large plants.

W. H. JENKINS.

FERTILIZER TERMS

Often the farmer forms a misconception of the value of a fertilizer from not thoroughly understanding the terms that the fertilizer-man uses in his analysis labels. The loose practice of using these terms allow the fertilizer-man to employ the largest figures in his guarantee, and since figures never lie, any error that may occur is not his, but the farmer's. For instance, a brand that contains 100 pounds of phosphoric acid to the ton may be guaranteed to contain 218 pounds of bone phosphate, which is true; and a brand that contains 100 pounds of nitrogen may be guaranteed to contain somewhat more than 120 pounds of ammonia with perfect truth. But here's the trouble; the figures 218 and 120 look bigger to the farmer than 100, though in reality they are not, because they are merely another form of the same thing.

It will be useful, therefore, for the farmer to know just how to convert the figures of any advertised term into an equivalent that he is better acquainted with. For example, let us suppose the case already given; the farmer wants to know how much phosphoric acid there is in 218 pounds of bone phosphate. He multiplies 218 by .458 and gets 99.84, almost 100 pounds of phosphoric acid. Now he is on his own ground.

By using the following table, and calculating in the same way, he may find out just what a given brand contains in the terms he best understands:

TO CONVERT	MULTIPLY BY
Ammonia.....	Nitrogen.....0.8235
Nitrogen.....	Ammonia.....1.214
Nitrate of Soda (pure).....	Nitrogen.....0.1647
Bone Phosphate.....	Phosph. Acid, P <sub>2</sub> O <sub>5</sub> .....0.458
Phosph. Acid, P <sub>2</sub> O <sub>5</sub> .....	Bone Phosphate.....2.183
Muriate of Potash.....	Actual Potash, K <sub>2</sub> O.....0.632
Actual Potash, P <sub>2</sub> O.....	Muriate of Potash.....1.583
Sulphate Potash (pure).....	Actual Potash, K <sub>2</sub> O.....0.54
Actual Potash.....	Sulphate Potash.....1.85

M. G. KAINS.

CORRESPONDENCE

**FROM MISSOURI.**—Any man with good management and push will succeed here in farming. The farms are well improved. Corn yields from forty to sixty bushels an acre; wheat, eighteen to twenty-five, and oats, thirty to forty. Fine timothy and clover are grown. Land sells at from \$30 to \$60 an acre, according to improvements. Our markets are near and good. Hired hands get \$13 to \$18, or more, a month.  
Linkville, Mo. A. P. H.

**FROM WASHINGTON.**—The climate of Klickitat county is unsurpassed for health, for grain and for fruits of many kinds. The vicinity of Lyle is one of the best fruit localities on the Columbia river. There is no place on the Pacific slope that has as mild, even and regular a temperature as that of Lyle. I will quote from the records of the weather-station at Pine Hill: "September, 1899, mean temperature for the month, 67 degrees; October, 49 degrees; November, 45 degrees; December, 40 degrees; January, 1900, 40 degrees. The precipitation for the above five months was 14 70-100 inches; total snowfall during same time, 14 10-100 inches." February 1st raspberries were in bloom, also wild flowers in the fields, and stock of all kinds were doing well on the range. We have no fears of cyclones or blizzards, and have no epidemics. Homesteads can be had, but they are principally timbered lands that with hard work and some means will make desirable homes. Improved land can be bought for from \$4 to \$20 an acre. Lyle has daily steamboat connection with Portland, Oregon, and with The Dalles City on the Columbia river, ten miles distant, and will have rail connection with the outside world in the near future.  
Lyle, Wash. T. M. W.

- ARMSTRONG & McKELVY Pittsburgh.
- BEYMER-BAUMAN Pittsburgh.
- DAVIS-CHAMBERS Pittsburgh.
- FAHNESTOCK Pittsburgh.
- ANCHOR Cincinnati.
- ECKSTEIN
- ATLANTIC
- BRADLEY
- BROOKLYN New York.
- JEWETT
- ULSTER
- UNION
- SOUTHERN Chicago.
- SHIPMAN
- GOLLIER
- MISSOURI St. Louis.
- RED SEAL
- SOUTHERN
- JOHN T. LEWIS & BROS CO Philadelphia.
- MORLEY Cleveland.
- SALEM Salem, Mass.
- CORNELL Buffalo.
- KENTUCKY Louisville.

**P**RACTICAL painters say that when they come to repaint a house which has been painted with ready-mixed paint or combination White Lead (so-called), it costs more to prepare the surface than to apply the paint.

The moral is to use only Pure White Lead, because it is not only more durable, but is always in good condition for repainting. These brands are genuine.

**FREE** For colors use National Lead Company's Pure White Lead Tinting Colors. Any shade desired is readily obtained. Pamphlet giving full information and showing samples of Colors, also pamphlet entitled "Uncle Sam's Experience With Paints" forwarded upon application.

National Lead Co., 100 William Street, New York.

**KEYSTONE QUICK HAY MAKERS.**

**KEYSTONE Side-Delivery Rake** tosses the hay into a light, airy, continuous winnow to cure without bleaching. Hastens curing—saves use of tedder—gathers no trash—Makes A. 1 hay. Rakes wide, fast, clean. No dumping—any boy can use it. Follows mower closest. Leaves hay best shape for loader.

**KEYSTONE Hay Loader.** Attached to rear of wagon, runs light, requires no extra horses. It loads a wagon in five to ten minutes from winnowers or rick. Gets all the hay without any trash. Does not thrash off leaves. Saves time and labor when both mean money.

**KEYSTONE Three Feed Hay Press,** complete with horse power. Has three feeds to every round of the power, giving  $\frac{1}{2}$  greater capacity than others with same power and help. Steel and iron throughout—no cog wheels on horse power—no release jerk to sweeps—press always on wheels.

Simple—Strong—Successful.

**Simplest. Strongest. Speediest.**

Write for full descriptions to **KEYSTONE MFG. CO., 21 River St., STERLING, ILL.**

**Choose a Carriage**

With the help of our catalogue. It offers a wider choice of vehicles, harness, robes, blankets and horse accessories than dealers carry in stock, at prices lower than any dealer can quote. We are carriage and harness makers on a big scale, with every facility for turning out the best work at the least cost.

**You Save the Difference** between the maker's and the dealer's price when you buy from us. Money returned and freight paid both ways if you are not satisfied with your purchase. Write for the catalogue—it's free.

**THE COLUMBUS CARRIAGE & HARNESS CO., Columbus, Ohio.**

No. 2016 Carriage. Price \$98.00.

**WE SAVE YOU MONEY ON FERTILIZERS.**

Buy your fertilizers Direct at Wholesale Prices, and get your money's worth.

**SPECIAL OFFER TO CLUB PROMOTERS.**

WRITE FOR PRICES, SAMPLES AND PAMPHLET.

**WALKER, STRATMAN & COMPANY, Pittsburgh, Pa.**

**1900 HIGH GRADE**

**YOU CAN EASILY EARN**

bicycles, sewing machines, house furnishings, ladies' or gentlemen's watches, cameras, mandolins, guitars, violins, silverware, dinner sets, guns, and your choice of a hundred other articles, all guaranteed. Simply sell a few boxes of our unexcelled toilet soaps and any of them are yours. Send no money. We trust you. Girls and boys do as well as older people. Write at once for full information. We mail handsome illustrated catalogue free. Address Great Northern Soap Works, 92 Lake St., Oak Park, Ill.

**The 20th CENTURY POULTRY BOOK**

is the very latest, up-to-date authority on the poultry business in this country. It treats the entire subject in a masterful way drawn from years of ripe experience in conducting the largest pure blood poultry plant in the country. Treats incidentally of the newest and best things about the world famous Reliable Incubators and Brooders. Sent to anybody for 10c to cover postage. **Reliable Inc. & Brooder Co., Box B 41 Quincy, Ill.**

**ECONOMY IS THE KEY TO WEALTH.**

You can save money by buying your woven wire fence from us.

**WE SELL DIRECT TO THE FARMER At Wholesale Prices.**

We use only the best quality of steel wire, all galvanized; no small wires used; it's all interwoven; the stays can't slip. Write to-day for circulars and prices.

**ADVANCE FENCE CO., 116 Old St., Peoria, Ill**

**ORNAMENTAL FENCE!**

25 different designs, they are all steel and cheaper than wood fence. Special prices to Churches and Cemeteries. Write us for catalogue.

**KOKOMO FENCE MCH. CO., 427 NORTH ST. KOKOMO, IND., U. S. A.**

**EVERY WOMAN**

Can buy a **WORLD'S WASHER** on trial and no money paid until it is perfectly satisfactory. Washes easy. Clothes clean, sweet and white as snow. Child can use it. I pay freight. Circulars free. **C. E. ROSS, 110 Clean St., Lincoln, Ill.**

**4 Buggy Wheels with Tire on, \$6.75 With Axles and Boxes Set, \$9.75**

I make all sizes and grades. Carriage and Wagon Hardware of every description. Send for catalogue giving prices on wheels 3 to 4 in. tread, with full and plain instructions how to order. Address **W. F. BOOB, Center Hall, Pa.**

**Makes The Lawn Beautiful.**

**HARTMAN STEEL ROD LAWN FENCE** adds to the attractiveness and value of the home. Strong and durable; keeps out everything but the sunshine. Unequaled for School Lawns, Church Enclosures, Parks, Cemeteries, Private Lots, etc. Catalogue free.

**HARTMAN M'FG CO., BOX 26 ELLWOOD CITY, PA. Or Room 77, 309 Broadway, New York City.**

**BUCKEYE FORCE PUMPS**

Are Leaders in the Trade because they work easy, throw a steady stream, do not drip, do not freeze, but

**PLEASE ALL WHO USE THEM**

They are made to pump and to last, and they do both. The complete embodiment of pump goodness. Write for circulars.

**MAST, FOOS & CO., 24 River St., Springfield, Ohio**

**Soon Saves Its Cost. A 12-Year Old Boy**

A Labor Saver, can do more and better work, either in the field or garden, with the

**HAND CULTIVATOR**

than three men can do with common hoes. Plows, hoes, cultivates—stride or between rows. If no agent in your town send \$1.35 for sample delivered and terms to agents.

**Ulrich Mfg. Co., 43 River St., Rock Falls, Ill.**

**From Manufacturer to You**

The original and still **THE BEST HARROW** of its kind. Of best seasoned white oak. Teeth of best oil tempered steel. Provided with guards. Channel steel, never-slip clips for holding teeth. Strong, durable and efficient. Full line agricultural implements—many specialties.

Full line of Buggies, Surreys, Road and Spring Wagons, Harness, etc. Write for free catalogue which explains why we can sell dependable goods at lower prices than others.

**Cash Supply and Manuf'g Co., Dept. B, Kalamazoo, Mich.**



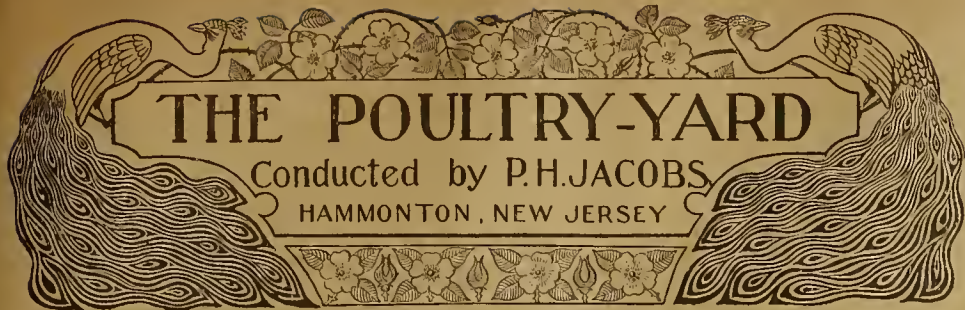

REMEDIES FOR GAPES

AMONG the suggested remedies for gapes by investigators is a hen's feather stripped of its barbs near the point introduced into the trachea and rotated like a brush, to detach the worms. The practice is not approved, however, as in the first place the worms are too firmly attached to be removed by the friction of the barbs of a feather. Should they be detached, however, they would only be pushed to the root of the trachea, where, forming a ball, they would augment the obstruction in the tube, and thus bring about more promptly the death of the bird. Some, on the contrary, believe in the efficiency of this method, and that this efficiency may be increased by impregnating the feather with a germicide substance. Spirits of turpentine has also given excellent results, but unless great care is exercised with this method the chicks may be seriously injured. One of the most rational methods of treatment has been pointed out by one who did not stop with the methods above mentioned, but who obtained much success with the following means combined: Removal from the affected places (or places where birds which had been affected were kept), and complete replacement of the conditions by new ones in which hemp-seed and new grass figure prominently; finally for drink an infusion of rue (ruta) and garlic instead of ordinary water. It has been said that the eggs ejected from the birds in a coughing fit hatch in the water, and that the embryo may live in this medium for many months. The birds are infected by drinking the water containing these embryos. It is always beneficial and indispensable to disinfect the soil of the inclosures after the removal of the birds. One of the best means of destroying the eggs and embryos which exist in the soil of the contaminated inclosures consists in sprinkling it with water containing in solution a sufficiently large quantity of salicylic or sulphuric acid, one gram (15½ grains) to a liter of water (about one quart), for example. Great care should also be taken to isolate the sick chicks on the first appearance of the symptoms of the disease, and to keep them closely confined until complete and well-confirmed recovery occurs. The cadavers of the dead birds must be burned or deeply buried to prevent a re-infection. Air-slaked lime freely used on the soil is a preventive of gapes.

SHELTER IN ALL SEASONS

No matter what the season of the year may be fowls should not be exposed. If they are strong and healthy they will withstand many changes, and if well fed and well guarded from the elements will pass over the critical periods with small loss. But no one owning valuable fowls will risk their safety by exposure to the vicissitudes of the weather at any season. Leg-weakness comes directly from exposure to severe cold or continued dampness. There is seldom any remedy that touches this weakness when once thoroughly established. It more frequently occurs with fowls that have not come to maturity before the cold weather sets in. The growth is at once retarded, the fowl dwarfed, and the muscles and tendons hardened. The fowl is then a sure victim for roup. Sometimes, if the weather is dry and warm, or the fowls are allowed a dry, sunny cover under glass during the day, it may be conquered. They may be fed on strong food, such as wheat and animal and vegetable materials, with a few drops of tincture of iron administered to them in the drinking-water, which should be supplied.

HATCHING NEXT YEAR'S LAYERS

If a pullet is of a large breed she does not fully mature until eight or ten months old (that is, until old enough to begin to lay), and she should be hatched in March or not later than the first week in April if she is to lay during the winter. Such a pullet will be eight months old in November, and can be of good service, but if pullets are not hatched until May there is a liability of their being unprofitable until spring. The small breeds, however, can be hatched as late as May,

which gives them time to mature by November. Now, this fact is one which has not received the consideration of many, and the question comes up for discussion whether it is more profitable to hatch pullets as early as March, or to hatch them later and not expect them to lay before spring. It will not pay to have a flock of fowls and get winter prices for eggs unless the hens lay more than the average number of eggs usually received from a flock in winter, as the greater cost of labor, eggs, shelter, etc., as compared with summer reduces the profit proportionately. It is better to retain the hens that have molted than to take any chances with untried pullets, yet the large majority of those who raise fowls seem to prefer pullets. An account with the flock will demonstrate that the hen gives the larger profit, as the cost of raising a pullet is an item to be met. If early pullets are fed on nitrogenous food and kept warm they will probably do better than the hens for awhile, but it is seldom that all the members of a flock of pullets begin laying at the same time. It is not until after Christmas, when the pullets have completed their growth, that they begin to lay regularly, and hence the matter of when to hatch pullets for the succeeding year is a very important one in poultry-raising.

SELECTION OF BREEDS

Which are the best breeds is an inquiry often received, and it is impossible to give a satisfactory reply, as each breed has its advocates. There is no breed that will serve as a superior egg-producer and yet excel for the table. Hardiness must be principally considered. If the climate is cold the Asiatics should prove excellent for a large city lot, as they are contented in confinement; but then there is the heavy feathering on the legs and toes, which is objectionable in wet weather. The Plymouth Rocks are more suitable for a damp location, but are not as contented in confinement as the Brahmas. The Plymouth Rocks, however, are equal to any breed for hardiness, egg production and the table combined, yet there are breeds that rival them as layers, and they are not equal to some for the table, but as a "combination breed" they rank high. The Langshans perhaps surpass them in some respects, but many object to black fowls. It is a very difficult undertaking to decide on any one breed as the best, because what may be lost in one respect can be gained in some other direction. It may be added, also, that a "breed" consists of many birds, and all are not alike, hence there are meritorious birds and worthless ones in all breeds and flocks. No person can claim that a particular breed is the best without meeting with some opposition, as each breed has its admirers who are willing to affirm that it is superior to all other breeds.

COLORS OF CHICKS

Do not be discouraged if chicks do not appear true to color when hatched. No chicks are hatched entirely black, as there will be some white on them when they come out of the shells. This is the case with the Langshans, Black Java, Black Spanish, Black Hamburg and Black Cochins breeds, but after the feathers begin to take the place of the down on their bodies the white passes away and the chicks soon become entirely black. If the chicks from white breeds appear to have "off-color" they will become of the correct color later on. In fact, sometimes when the chicks are pure white it may denote that they were not strictly pure, but a few years more of breeding will fix the color, as the darker birds of the white breeds are all being culled out.

NUMBER OF EGGS TO THE HEN

Do not estimate on a large number of eggs from a flock of one hundred hens. Although it is the custom to concede twelve dozen eggs from one hen in a year, it may safely be suggested that one hundred eggs will come nearer the number. A single hen may lay as many as two hundred eggs in a year, but in a flock there will be some that will not lay one third of that number. All the sick, aged, immature and overfat hens are

included in a flock, and the average will be reduced in proportion. The smaller the flock the better, as experience has shown that large flocks do not pay as well as smaller ones, in proportion to food consumed, but the value of the labor bestowed is less for a large flock proportionately.

BREEDS FOR BROILERS

To produce the largest and plumpest broilers in the shortest time one should select certain hens from which to procure eggs for that purpose. A chick from a Plymouth Rock cock and large Asiatic hen will not only make a superb broiler, but it will weigh half a pound more at ten weeks old than will the chicks bred without regard to whatever breed or cross they may be. As a dozen hens will lay a large number of eggs it will not be a difficult matter to keep that number apart from the others, and it will pay to do so if first-class chicks are desired.

LEGHORNS

The Leghorns belong to the Mediterranean class of fowls, and are non-sitters, consequently the chicks must be hatched under hens of some other breed. Though small in size they lay fairly large eggs, sometimes fully as large as eggs of the Brahmas, and the eggs are white in color, without any variation of shade. The young chicks are active and hardy, but they feather rapidly, and must therefore be fed often. They also mature early, the little cockerels sometimes beginning to crow when only seven weeks old, and the pullets have been known to lay when but a few days over the age of four months.

CORRESPONDENCE

**DESTROYING LICE.**—I would like to send you a receipt for killing lice in hen-roosts. Throw water over the inside of the hen-house, and then put wood ashes over it. I have kept from two hundred to four hundred hens for twelve years, and have had no trouble with lice. I only clean the roosts about three times every year, and dust them with ashes once in two or three years. For roup I steep sweet-fern, stick their heads into the liquid, open the hunches with a knife, and the hens get well. Sweet-fern will cure the worst cases known of roup. I think your paper is the best of all for old and young. A. J. W. Canterbury, Ohio.

INQUIRIES ANSWERED

**Scalded Legs.**—"Subscriber" writes: "Please give a remedy for scalded legs on poultry." **REPLY:**—You probably refer to "scaly" or "scabby" legs. Anoint twice a week with crude petroleum. **Mating Fowls.**—G. A. G., Starke, Fla., writes: "How long is it necessary to pen the male with the hens to insure fertility of eggs?" **REPLY:**—Opinions differ, some claiming five days and others ten. **Bantams.**—G. E. A., Mt. Vernon, Ill., writes: "Is there a breed of fowls known as Cuban bantams?" **REPLY:**—There is no such breed known in this country that is recognized.

**Picking the Comb.**—E. D. J., Newport News, Va., writes: "Why do some of the hens persist in picking the male's comb, keeping it bloody?" **REPLY:**—It is an acquired vice. Kill the guilty hens or remove the male from the flock for awhile.

**Gapes.**—B. H. H., Harris, Tenn., writes: "Is there a remedy for gapes that will make a cure?" **REPLY:**—An excellent remedy is to use a drop of turpentine on a bread-crumble. Keep the chicks on new, clean ground, and feed on clean boards. Using a straw or horsehair in the windpipe is unsafe unless done by an expert.

**Preserving Eggs.**—W. G., Franklin, Cal., writes: "Please give best method of keeping eggs for higher prices." **REPLY:**—1. Use eggs from hens not with males. 2. Keep them in a cool place, on racks or in boxes. 3. Turn them twice a week. 4. No solutions or chemicals are required.

**Dying in the Shells.**—C. E. G., Exeter, Neb., writes: "Why do chicks die in the shells when nearly ready to hatch, only half the eggs hatching?" **REPLY:**—It is due to the eggs, as those from very fat hens, immature pullets or weakly fowls sometimes fail. As some of the eggs hatched the fault must be with those not hatching.

**Brassy Feathers.**—F. H. W., Johnstown, N. Y., writes: "I am a breeder of white Games. How can I prevent brassy feathers?" **REPLY:**—Such feathers known as "straw-color" appear on all white breeds. Showmen confine the birds in dark places for a week or two before showing, but on exposure the straw-color returns. With the new (molt) feathers it is absent for awhile. It cannot be entirely eradicated.

**Overfeeding.**—F. S., Higginville, W. Va., writes: "My fowls, after eating heartily, went to roost. The next morning a large Buff Cochins lay dead on the floor. The hens appear sometimes stupid. The dead bird was found fat upon examination." **REPLY:**—The cause was what may be termed apoplexy, due to excessive feeding, especially of grain, and probably not having sufficient exercise.



**Admiral Buggy**—Fancy painted; fancy trimmed with shafts. Price, \$50. Dealers would charge \$75.

**We Sell Vehicles and Harness at Less Than Wholesale Prices.**

On the above buggy the saving to the purchaser in the neighborhood of \$25. The quality is all right in every particular. To assure you of this we will ship this buggy anywhere subject to your examination and approval. If not right and satisfactory you return it at our expense. We have a most complete line of Carriages, Surreys, Traps, Phaetons, Spring Wagons, etc., and all kinds of single and double harness. Send today for free illustrated catalogue from which to make your selection. **Kalamazoo Carriage & Harness Co., Box 86 Kalamazoo, Mich.**

**HATCHING IN 10 DAYS**

would be an improvement on the old way, but WE can't do it. WE CAN furnish an INCUBATOR that will hatch all hatchable eggs and do it with less attention than any machine made. It does it because it is made right and has all late improvements. Sold at a low price and guaranteed. Catalogue in 15 languages, 6 cts. **DES MOINES INCUBATOR CO., Box 61, Des Moines, Ia.**

**IT COST US \$4,000 Costs You 15c**

We have spent \$4,000 on our new book, "How to Make Money with Poultry and Incubators." It tells it all. Leading poultry men have written special articles for it. 192 pages, 8 1/2 in. Illustrated. It's as good as **Cyphers Incubator**—and it's the best. Out hatch any other machine. 16 page circular free. Send 15 cts. in stamps for \$4,000 book No. 71. Address nearest office. **CYPHERS INCUBATOR CO., Chicago, Ill. Wayland, N. Y. Boston, Mass.**

**HATCH** with the perfect, self-regulating, lowest priced first class hatcher—the **EXCELSIOR Incubator**

Hatches the largest per cent. of fertile eggs at the lowest cost. **GEO. H. STAHL, Quincy, Ill.**

**Costs Only \$1**

To find out what our Incubator looks like, materials used in its construction, send \$1 and we will ship you either size incubator, balance C.O.D. If all right pay the agent, if not instruct agent to return. Catalog Free. **FOREST INCUBATOR CO., Forest, Ohio.**

**The Star Incubator**

is best because simplest in construction and in operation. Hatches every hatchable egg. Positive directions and no moisture. Perfect hatcher. 60-egg size, \$6. Illustrated catalogue free. **STAR INCUBATOR CO., 34 Church Street, Bound Brook, N. J.**

**The IMPROVED VICTOR Incubator**

hatches all the fertile eggs; is simple, durable and easily operated; 168 page catalogue containing information and testimonials. Sent free. **GEO. ERTEL CO., QUINCY, ILL.**

**LIN-SEED OIL** with White Lead makes paint last for years on house, barn or fence. Mixed paints are doubtful quality; some are good and MANY ARE VERY BAD. For Linseed Oil and White Lead or Oil Meal, ask for Thompson's, or get circulars and prices. **THOMPSON & CO., 509 W. Diamond St., Allegheny, Pa.**

**INCUBATOR FREE** on trial. Most perfect. Latest improvements. **The New C. Von Culin.** Catalog FREE. Poultryman's plans 10c. Address: **Ave. 77 THE W.T. FALCONER MFG. CO., JAMESTOWN, N.Y.**

**DON'T SET HENS THE SAME OLD WAY**

The Nat'l Hen Incubator beats old plan \$ to 1. Little in price, but big money-maker. Agents wanted. Send for cat. telling how to get one free. **Natural Hen Incubator Co., B 22, Columbus, Neb.** A. Edwards writes, "Would not take \$100 for N. H. I. Plan."

**\$5,000 POULTRY CATALOGUE FREE!**

It is without a rival. Gives lowest prices of fowls and eggs. Over 50 breeds Turkeys, Geese, Ducks and Chickens. Hundreds of plates from life. 15 best poultry house plans. Treatise on diseases, how to feed, breed, etc. Send 10c. for postage. **J. R. Brabazon, Jr. & Co., Box 11, Delavan, Wis.**

**2000 PREMIUMS**

were awarded my fowls at 12 State Shows in 1899. **FOWLS AND EGGS** Largest Ranch in the west FOR SALE. Send 5c for illustrated catalogue. **CHAS. GAMMERDINGER, Box 63, Columbus, O.**

**GREIDER'S FINE CATALOGUE**

of prize winning poultry for 1900. The finest poultry book out. A perfect guide to poultry raisers. Gives price of eggs & stock from the very best strains. It shows the finest chickens & decorates them all. 50 different varieties. Everybody wants this book. Send 6c. in stamps. **B. H. GREIDER, Florida, Pa.**

**POULTRY PAPER**, illust'd, 30 pages, 25 cents per year. 4 months' trial 10 cents. Sample Free. 64-page practical poultry book free to yearly subscribers. Book alone 10 cents. Catalogue of poultry books free. **Poultry Advocate, Syracuse, N.Y.**

90 Varieties Choice Poultry, Eggs, Pigeons, Hares, Described colored 60-page book, 10c. **J. A. Bergery, Telford, Pa.**

**DEATH TO LICE** on hens & chickens. 64-p. Book Free. **D. J. Lambert, Box 303, Apopass, Fla.**



## QUERIES

READ THIS NOTICE

Questions from regular subscribers of FARM AND FIRESIDE relating to matters of general interest will be answered in these columns free of charge. Querists desiring immediate replies, or asking information upon matters of personal interest only, should inclose stamps for return postage. The full name and post-office address of the inquirer should accompany each query, in order that we may answer by mail if necessary. Queries must be received at least two WEEKS before the date of the issue in which the answer is expected. Queries should not be written on paper containing matters of business, and should be written on one side of the paper only.

**Cure for Egg-eating Dogs.**—J. F. T., Breckenridge, Mich., sends the following: Blow out the egg, place in the shell one half ounce of ammonia, and seal up the holes. Put this in the dog's way. After crushing the shell the dog will run under the house every time he sees an egg.

**Mottled Butter.**—A. N., Franklin, Indiana, writes: "Kindly give a remedy for streaked butter. My butter is all right every way except in color."

**REPLY:**—The light-colored streaks can be prevented by working the butter sufficiently to thoroughly distribute the salt. Use only fine dairy-salt of best quality.

**Weevil in Beans and Peas.**—D. A. B., Lorain, Ohio, and others. When the beans and peas are harvested and cleaned put them in a tight box or barrel. Place a saucer on top of the seeds and pour into it a couple of ounces of bisulphid of carbon. Cover the box or barrel closely. The vapor of the liquid will kill the larvae of the weevil in the beans or peas without injuring them for seed or table use. Another way is to expose them for a short time to heat of about 140 degrees Fahrenheit.

**Potato-scab.**—G. F., Saegertown, Pa., and others. Potato-scab is prevented by soaking the seed-potatoes for one and one half hours in a solution of corrosive sublimate. The proportion is two ounces of corrosive sublimate to sixteen gallons of water. In a barrel or large tub first dissolve the corrosive sublimate in a few gallons of hot water, and then dilute to the proper proportion. Put the potatoes in a coarse sack and immerse them in the solution the time required. Handle corrosive sublimate carefully, as it is very poisonous.

## VETERINARY

CONDUCTED BY DR. H. J. DETMERS

To regular subscribers of the FARM AND FIRESIDE answers will be given through these columns free of charge. Where an immediate reply by mail is desired the applicant should inclose a fee of one dollar, otherwise no attention will be paid to such a request. Inquiries should always contain the writer's full address. Queries must be received at least two WEEKS before the date of the issue in which the answer is expected. Veterinary queries should be sent directly to Dr. H. J. DETMERS, 1315 Neil Avenue, Columbus, Ohio.

**NOTE:**—Parties who desire an answer to their inquiries in this column must give their name and address, not necessarily for publication, but for other good reasons. Anonymous inquiries are not answered.

**A Morbid Growth in the Eye of a Cow.**—D. D. D., Great Bend, Kan. Please consult answer to C. G. W., Pender, Kan., in the FARM AND FIRESIDE of March 1st.

**Worms (?) in a Cow's Tongue.**—C. H., Groesbeck, Ohio. You are right. Ignorant people sometimes mistake the papillae on the surface of the tongue of cattle, especially if for one cause or another a little swelled, for the heads of worms, and then subject poor bossy to a very irrational torture.

**Probably Garget.**—R. F. M., Henderdon, W. Va. If there are clots of coagulated milk in the udder, they must be removed by frequent and vigorous milking, and after this has been done, and the milk has been restored to a normal condition, it may be advisable not to continue the milking too long, but to make the cow dry as soon as it can with safety be done.

**A Peculiar Skin Disease.**—A. B., Harmony, Md. A skin disease of cattle that presents all those symptoms you mention is not known to me, unless it be that you exaggerate minor symptoms and overlooked more important and more characteristic ones. It will be best to have your cow examined by a veterinarian, and then it may be found that the case is simple enough.

**Lame on Three Feet.**—A. C. S., Mackinaw, Mich. There is probably no doubt that the lameness of your colt is caused by ring-bone, but if three feet are affected, notwithstanding that the animal is only two years old, and perhaps has never done any work, the prospect of removing the lameness is exceedingly slim. Concerning the treatment of ring-bone see the FARM AND FIRESIDE of November 15th, 1899.

**Discharges from Nose and Mouth.**—A. W. V., Windsor, Cal. From your description it appears that the apparently copious discharges from the nose and mouth of your horse have their source either in the frontal or maxillary sinuses, or in the so-called air-sacs. Before anything rational can be done the exact source of the discharge must be ascertained by a careful examination. Therefore, and also because the treatment in either case, will require a surgical operation that can be performed only by a veterinarian well versed in anatomy and pathology, I advise you to have your horse examined and treated by a veterinarian.

**Diseased Brain.**—T. M. E., Atkinson, Neb. The queer actions or crankiness of your calf result from a diseased brain. Animals are subject to brain diseases just as well as men. A cure is possible only, though hardly probable, if the exact seat of the pressure upon the brain can be ascertained and the pressure itself can be removed. If it cannot a cure is out of the question.

**One Dry Teat.**—L. W., Tualatin, Oreg. If your cow is otherwise healthy, only ceases to yield milk from one quarter of her udder a few days after she has become fresh, without that quarter showing any inflammatory swelling, it will be best to leave it alone. The cow will produce nearly as much milk from three quarters as she would from all four, so the loss will be less than the inconvenience.

**Warts on Cow's Teats.**—S. F., Oaklana, Md. The best or rather the only time to remove warts from the teats of cows is when the cow is dry. Warts that have a plainly developed neck are best removed by means of a ligature applied around the neck of the wart as tight and as close to the teat as possible. Small sessile warts are best removed by means of a careful application of caustics. See numerous answers given to "wart" questions in these columns.

**Melanosarcoma.**—C. D., Sergeants Bluff, Iowa. What you describe is a melanosaarcoma (a black semi-malignant tumor), and of rather frequent occurrence in gray horses. If never irritated such tumors may exist for years without showing malignant properties, but if irritated or wounded they invariably become malignant. The one you describe I have no doubt can be extirpated by a surgical operation, but whether much is gained thereby is another question; for in most cases in which these tumors make their appearance on the surface of the body there are also some in interior organs, and it seems that where the former are removed the latter resent it and show a malignant tendency by a more vigorous growth. If the one you describe is interfered with at all it must be removed in a most thorough manner by a competent veterinarian.

**So-called Bog-spavin.**—T. H. S., Basin, Neb. What you describe is so-called bog-spavin (an abnormal accumulation of synovia in the capsular ligament, and consequently an enlargement of the latter). It was caused by an over-exertion of the right leg when the mare for a long time was unable to use the left one, and is now increasing in size simply because the mare is heavy with foal. Since it does not cause any lameness I advise you to leave it alone. You may possibly succeed in effecting a temporary reduction after the mare has foaled by repeated applications of tincture of iodine or by a continued application of gentle pressure by means of a properly constructed pad, but after that any severe exertion will be apt to increase it to its former size.

**Infectious Ophthalmia and Lousy Cattle.**—H. H., Pender, Neb. Infectious or epizootic ophthalmia, or ceratitis (inflammation of the eyes), of cattle is not caused by lice, as you seem to think, and has nothing to do with lousiness, notwithstanding that lousy cattle may become infected with the eye disease, and cattle with diseased eyes may become lousy. Cattle can be freed from lice by more than one remedy, provided it is properly applied, and at the same time the premises in which the lousy cattle have been kept are thoroughly cleaned, so that nothing whatever on or in which lice and nits may have found a temporary hiding-place will remain. A comparatively clean way of freeing cattle from lice is at any rate much cleaner than the use of a tobacco decoction, to wash them first with soap and warm water and then with a four or five per cent solution of creolin in water. It is advisable to repeat the washing at least in about five days.

**Out of Condition.**—D. G. B., Leslie, Mich. "Out of condition" is nothing more nor less than a meaningless phrase. Your horse probably suffers from chronic indigestion, caused, may be, by some chronic morbid changes in the digestive apparatus, or possibly by the presence of a large number of intestinal worms. Condition powder can do no good, and to file the crowns of the molars smooth can only make things worse, because if the molars or grinders, which have to act in a similar way as the millstones in a grist-mill, are deprived of their rough or uneven surface they are thereby prevented from performing their office of grinding the food and thus preparing it for digestion. Neither knowing the exact condition your horse is in, nor the causes that produced the indigestion, the only advice I can give you is to send your horse to a good pasture as soon as the season will permit it, and to exempt the same from all kinds of work until a complete recovery has been effected.

**Perhaps a Case of Navicular Disease.**—A. M. S., Big Sandy, Tenn., and T. R., Dungeness, Wash. The lameness as you describe it is such as is caused by navicular disease. The best way to arrive at a reliable diagnosis is the following: First make a mental note of the degree of lameness the horse shows, then have a bar-shoe put on the lame foot in such a way that considerable weight will be thrown on the frog. If it is navicular disease that causes the lameness the latter at once will be very perceptibly increased, but if the lameness is caused by something else no perceptible difference will be observed. Of course, as soon as the diagnosis of navicular lameness has been secured, the bar-shoe must be removed and a shoe put on that throws as little weight as possible upon the posterior part of the hoof. Concerning the treatment of navicular diseases, which, however, as a rule will be vain, consult the FARM AND FIRESIDE of November 15th, 1899. The shrinking of the muscles of the shoulder you have observed is, except during the first time, a regular attendant of navicular disease.

**Multiple Abscesses.**—H. J. M., Manorhill, Pa. What you describe is a case of multiple abscesses, or rather of pyemia. The infection undoubtedly started through the cut above the hoof. If, when this reaches you, the horse is yet alive, and no abscesses have as yet developed in interior organs, the animal may possibly yet be saved if treated by a competent veterinarian, undoubtedly available in your state.

**A Sweet Oilish Smell.**—B. G., Union Lake. The "sweet oilish smell" emanating from your cow, if not proceeding from the skin, may have been due to some digestive disorder. The cause of the loss of flesh taking place later I cannot tell you, because a loss of flesh may be produced by a good many different causes. May it be that your cow is lousy? If she is, the peculiar or "sweet oilish" smell and the subsequent loss of flesh would be accounted for.

**Looks Like a Case of Rachitis.**—F. W. T., Park, Ohio. Since your colt is steadily improving I do not deem it necessary that you do anything by way of medication. Continue to feed well, particularly enough good oats, good hay and occasionally a bran-mash; then allow the animal all the voluntary exercise it is willing to take and the season and the weather will permit, but do not break the same for work this coming spring. You certainly were right when you concluded that the colt had no blood to spare, and prevented the proposed blood-letting. Although it is exceedingly doubtful whether the colt will ever make a very valuable or high-priced animal, I have no doubt that the same, if the improvement continues, will yet develop into a useful working-horse.

**Probably Attacks of Vertigo.**—M. H. S., Columbus, Ga. What you describe appear to be attacks of vertigo. Most cases of vertigo must be considered as incurable, and concerning all of them but little can be done. As a rule the attacks are more frequent in the spring of the year than at any other season, and in a majority of cases the attacks make their appearance only when the horse is in harness. I consider it as important not to feed too heavy, never to harness such a horse immediately after a heavy meal, and not until there has been sufficient time for the process of digestion to get a good start; also to see to it that the harness is in every respect well fitting, but particularly that nothing, neither collar nor head-stall of bridle, press upon any vein carrying the blood from the brain back to the heart. It has been claimed that lacquered or shiny blinkers and sudden and rapidly repeated changes from light to comparative darkness; and vice versa, are, under circumstances, also able to call forth attacks of vertigo. Such cases, however, are probably very rare, and where they occur the blinkers can easily be removed and the sudden changes can be avoided.

**Wants to Know Cause of Death.**—L. J. M., Boltonville, Wis. Although you give a minute history of the case, I cannot tell you the cause of the death of your horse, because you do not give any symptom characteristic enough to base upon it a reliable diagnosis. If the horse was constipated it was a serious mistake to administer "binding" medicines or any opiates, and as to the linseed-oil, which was given afterward, I can only say that linseed-oil is a very dangerous medicine for horses on account of their great aversion to fats and oils, because even if it is swallowed and doesn't go down into the lungs, and thus cause a fatal pneumonia, it will for some time most thoroughly destroy the appetite. The post-mortem examination, as reported by you, gives no clue to the cause of death, as all important features were overlooked. Incidentally it appears from your description of the case that you very likely are in the habit of feeding your horses large quantities of bran. If this is the case, and if the fact is taken into consideration that your horse was seventeen years old, it must be considered as not improbable that your horse harbored an intestinal stone or concrement, which, interfering with the passage of the contents of the intestines, caused the attacks of colic you mention, the final constipation, and perhaps the death of the animal. A careful post-mortem examination, however, could and should not have failed to reveal its presence.

**Warbles.**—W. E. R., Fleming, Col. The larvae of the gadfly of cattle (*Oestrus bovis*), which you call grubs, produce the morbid condition in the skin and subcutaneous tissue known as "warbles." About this season of the year these larvae arrive at maturity, crawl out of the warbles through a roundish hole in the skin, fall to the ground and immediately burrow into the same. Thus hidden in the ground they are changed into pupae, and then after a few weeks are changed into gadflies. To prevent the formation of warbles, first every larvae should be killed as soon as it leaves its hiding-place, or, as that moment is seldom observed, it is best to squeeze them out of the warbles, something that is easily done at this season of the year, and then to step on them with the foot as soon as they drop to the ground. Secondly, cattle, but particularly young cattle, and especially such as are rather wild or excitable, and have a rough coat of hair, should be kept away from all such places where the gadflies are swarming; or if that cannot be done they should be covered with a light muslin blanket, as is done in several parts of Europe. Thirdly, cattle, but young cattle in particular, for it is these that have to suffer the most from the attacks of the gadfly, should be in a first-class condition and have as smooth a coat of hair as possible when sent to pasture, because such animals, especially when also of a quiet disposition, seldom suffer much from the attacks of the gadfly; or even if the eggs of the gadfly are dropped on a smooth and sleek coat of hair, they seldom stick, and consequently do not hatch.

## Honestly, Now,

don't you need a separator which extracts 99.9-10% of the butter fat, which a child can run, which delivers the cream in perfect shape for churning, and which is of perfect material and workmanship. The

## Empire Cream Separator

has all these points of excellence.

Don't fail to write for free illustrated catalogue, if you want most butter for least work.



U. S. BUTTER EXTRACTOR CO.,  
227 High Street, Newark, N. J.

## The Big 4

- 1 The Dixie and Columbia Grain Threshers, the greatest savers and cleaners on earth.
- 2 The Matchless Clover Huller, if saves 1/4 more seed than any other machine and cleans it to perfection. . . .
- 3 The A. & T. Farm Traction Engines, and the easiest steamers and most durable in the world.
- 4 The A. & T. Saw-Mills, are up to date and saw true, marketable lumber. . . .

MANUFACTURED BY  
The Aultman & Taylor Machinery Co.,  
MANSFIELD, OHIO.

Send for free Illustrated Catalogue and mention this paper



WE carry a complete stock of all kinds of RUBBER and LEATHER BELTING. We buy our goods at Sheriffs' and Receivers' Sales. Write for FREE ILLUSTRATED CATALOGUE No. 34 on Hardware, Pipe, Roofing, Plumbing Material, Wire, Rope Dry Goods, Clothing, etc., etc. OUR PRICES are ONE-HALF of OTHERS. Chicago House Wrecking Co., W. 35th & Iron Sts. CHICAGO.

## "Goshen" Tanks

Represent Honest Tank Value...

and these are the reasons why: They are made of the best heavy galvanized steel; they simply cannot warp, swell or fall to pieces from drying out; heavy iron bound edges protect them from bending or denting.

ANTI-SEPTIC there is no place for disease germs in these tanks. Pure water makes good milk and butter; prevents many diseases, hog cholera, etc. Don't buy until you get our 48 page catalogue, sent FREE.

Kelly Foundry and Machine Co. 12 Park St., Goshen, Ind.

## The ROCKER WASHER

WARRANTED to do the family washing, 100 PIECES IN 1 HOUR. No need for washboard; no wear on clothing. Write for special prices and description. ROCKER WASHER CO., Clinton St., Ft. Wayne, Ind. 200000 in Use. Liberal inducements to live agents.

## VICTOR Low-Down WAGONS

Strongest, most durable, all-metal wheels, wide tires. Axles, hounds, bolsters, etc., of thoroughly seasoned woods. Cost one-half less than high wagons. Positively guaranteed. Write for description and prices. GEO. ERTEL CO., Quincy, Ill.

## THE BEST BUTTER

and the most of it is made by using our improved patent AQUATIC CREAM SEPARATOR. It takes all the cream out of milk, expels all foul odors and impurities in two hour's time. Better than any creamery made and costs less than half as much. For 1 cow up to 40. Can't get out of order. No experience necessary. Prices, \$5. to \$11. Free catalogue and testimonials. Reliable Agents Wanted. Aquatic Cream Separator Co., 125 Factory Sq., Watertown, N. Y.

\$2.75 buys a MAPLE AND BATTERY Carriage. \$5.00 Buys a Beauty complete with rubber tire wheels and paragon. Full line of Sleeping Coaches and Coaches. 48 page Catalogue Free. Address Dept. 11 VICTOR MANFG. CO. 161 to 167 Plymouth Place, CHICAGO, ILLINOIS.

FOR SALE—SEED CORN KANSAS' BEST. Write for Sample. HUMBOLDT GRAIN EXCHANGE, Humboldt, Kansas.



THE GRANGE  
 Conducted by MRS. MARY E. LEE, New  
 Plymouth, Ohio

ORGANIZE A GRANGE

Do you want a grange organized in your community? Do you want to take part in the great struggle for justice and humanity? Do you want to use your influence in the most telling way to elevate and educate mankind? Do you want to see better schools, more comfortable homes, laws more equitable? Do you want to improve your own condition? Then combine your forces. The law of the universe compels to organization. Observe Nature. An isolated tree soon decays and falls to the ground. Plant it with others and it will live for centuries. An individual tuft of grass has a hard time to exist and reproduce itself; but mass the tufts and we have the rich blue-grass regions of Kentucky, of which it is said you can ride miles and not see a weed. The combined forces of innumerable grass roots can put to rout every enemy of the weed kingdom. As it is in Nature inanimate, so is it in Nature animate. So long as a pack of wolves cling together they are almost invulnerable; but let one stray aside and it falls an easy prey to an enemy. Plainmen tell us that as long as a herd of cattle cling together they are safe; but let one stray away and death by some of its enemies soon follows.

The same law is applicable to the human race. A class of people unorganized become a prey to the combined forces of a more powerful people. Powerful because of the strength that numbers give, but more so by reason of the increased brain-force gained by meeting and talking together; for in organizations, as well as everywhere else, there is always a struggle for supremacy. In this is the great safeguard of organized force, as well as the germ of its perpetuity. Would the peasantry of Europe, the serfs of Russia remain in so deplorable a condition if they had the intelligence to organize themselves into a body for self-protection? What gives our corporations such power? Organization. What force compelled unwilling millions of wealth to their hands? Organization. What is the one essential to their continued power? Organization. Let one of the trusts or corporations go to pieces and greedy enemies will be quick to pluck the victims. In our stage of civilization the inevitable concomitant of the law of self-preservation is that, unconsciously perhaps, one interest preys on every other interest. These interests, obeying the common impulse, take vengeance at every opportunity. Of what avail is the puny arm of an individual against these powerful forces? How can one person stand alone and wage successful combat with these warring powers?

Bring the matter closer home. How can the farmer hope to maintain his identity and perpetuate a race that can care for itself if he disobeys one of Nature's mandates? In the very nature of the case, whether consciously or unconsciously, his labor displaces that of another; his ownership deprives another of a part in the land he considers he has as good a right to as the farmer, who got his by inheritance. The farmer protects his birds, and the sportsman and milliner rebel. If he refuses to do his duty, and permits the birds on his land to be killed, disease follows in the wake of their destruction; his crops are ruined, his customers are defrauded by having palmed off on them inferior goods when their good money paid for superior products. In failing to do his duty, in neglecting to obey a universal law, he brings on himself the ill-will of his customers, and thus makes enemies of them. The same principle is observed throughout all Nature. What can be said of the judgment of the farmer who sets at defiance Nature's law; who neglects to throw around himself and family safeguards to protect their rights and liberties? In failing to do so he may show magnanimity, but it is vitiated by his stupendous folly.

Organize! Organize for self-protection, self-preservation and in order that you may hand down to posterity the priceless heritage of equal rights, equal opportunities with the rest of the world. What words of scorn, ridicule and condemnation can be strong enough for him who refuses to improve his heritage; who inherits a fair land and refuses to transmit to his offspring the blessings his father conferred on him; who has entrusted to him exceptional privileges and important duties, but will not perform them? Remember the parable of the talents.

We must ceaselessly agitate and educate along the line of self-preservation and self-

protection. We will find, the deeper we delve into the question, that we owe a moral duty to humanity thus to protect ourselves.

We ask all worthy farmers to unite with the grange in its efforts to better the moral, intellectual and financial condition of the farmer. We ask it not as a matter of class aggrandizement, not as a means of oppressing the weak, but of protecting ourselves. We believe that the greatest safeguard of our liberty lies in our ability to care for ourselves. We believe that the more competent we are to care for ourselves the more aid can we give to our weaker brethren, no matter where found. To a strong and sturdy race God intrusts many onerous but honorable responsibilities.

We believe that to the farmer who has maintained his integrity, courage and supreme faith in an Almighty God is intrusted a glorious mission. His contact with Nature has made him fearless and courageous; education has broadened his sympathies and enlarged his mental outlook. Organization will bind these forces into an impregnable barrier against the foes of right. This is the type of farmer we want; this is the type which will more readily organize and work. The farmer who skulks and dodges, who cannot stand fire, who has so misinterpreted the lessons Nature would teach him as to be little and narrow, sordid and mean, we do not want. He has no place in our ranks. Let him seek a people of his kind, and stay there. But the worthy farmer we want to unite with us, and I have faith to believe that when he comprehends the mission of the grange he will come with us and be one on whom we can depend.

CURIOSITY IN THE CHILD

Who has not seen the small boy or girl lying on the grass lazily watching the movements of an ant or beetle, or turning over boards and stones to find the hidden treasure of snail or worm, or imprisoning a bee in the cup of a flower? Is it all for the mere sake of sport? Is it in the spirit of cruelty they prod the snail or hamper the movements of the ants? Is it not rather the curiosity of an active mind inquiring after the reason of things?

Why not answer the questions asked? Why not get a small microscope, costing about \$1.25, and several books on Nature studies, and help develop the child's curiosity instead of stunting it? He will learn far more and easier now that he is interested than he will later on, when other matters press themselves upon him and he studies because he knows he ought to. It is with the development of the child's mind as with everything else—there are opportune moments when all things will come as easily and naturally as walking, running and jumping. Let the moment pass by, the opportunity go unheeded, and that which would have been play becomes serious work.

Following is a list of a few books on Nature studies suited to the child's mind: "Romance of the Insect World," "News From the Birds," "A Naturalist's Rambles About Home," "Short Stories of Our Shy Neighbors," and "Outdoor Studies." Any or all of these books would provide many pleasant and profitable hours for the child, and enable him to interpret the lesson the common things of life would teach.

After all, is it not more essential that the spiritual part of the child be trained than that he be fed and clothed luxuriously? Nature demands the first, not the last. Franklin's motto of "plain living and high thinking" is just as applicable now as ever before, and that dread sentence, "Whatever ye sow that shall ye also reap," finds corroboration in every life. Would you enjoy a happy old age, carefully attended and ministered to by your children? Then let their early inquiries find answer. What one can treat with aught but reverence old age who has seen and understood the processes of life—the constantly recurring seasons; the change from seed to ripened grain; the trees putting forth their leaves, carefully nurturing them, that they in turn may fall to the earth and protect the parent stem? All serve to teach the beauty of the duty of reverence. The matter of developing the child's instincts thus becomes a means of self-preservation, a storing up of a fund that none can draw from or diminish.

WORK OF THE LEGISLATIVE COMMITTEE

The legislative committee of the National Grange held a meeting at Washington, D. C., commencing March 6th, and transacted important business for the order. The committee appeared before the proper committees and made known the demands of the

grange on the various matters of legislation recommended by the National Grange. The committee was cordially received.

Special attention is directed to Senate bill No. 1439, relating to the interstate commerce commission. This bill is intended to give to the commission the powers it originally had. The law has been so emasculated by recent legislation as to be practically a dead letter. Patrons are asked to write their senators and representatives urging the passage of Senate bill No. 1439.

Special attention is also called to House bill No. 3717. This bill gives to states the right to legislate upon imitation dairy products when transported from one state to another in the original package.

It is a matter of profound significance that the farmers have the courage to defend their rights. But are all farmers doing their share in the defense of property? Are all using every legitimate influence to secure the desired legislation, or are they waiting for some one else to do the work? Remember that no matter how eloquently our legislative committee may plead, how just its demands may be, if it is not sustained by the vigorous efforts of the farmers themselves its efforts are of no avail. Other interests with powerful influences to back them are at the Capital looking out for their welfare. If necessary they can call, at a moment's notice, influential parties to their aid. When these interests do not conflict with right and justice their enterprise rises to patriotism. When it is contrary to the best interests of the people it becomes treason. Isn't it just as much treason for the farmers who have the power, but do not use it?

Each year we present our demands and our legislative committee goes to Washington. That we have secured as much legislation as we have has been because of the justice of our plea and the persistent efforts of a minority of the farmers. Change the minority to a majority and not a demand would be ignored.

GRANGE REPORTS

To those who have kindly sent grange reports we extend thanks. When we realize that the FARM AND FIRESIDE goes into every state in the Union, to Canada and Australia, it will be seen that purely local matter, such as the election and installation of officers, the list of subjects discussed, without giving the salient points brought out in the discussion, would be of little interest to the great mass of readers.

Tell us how you make your grange a success; what it has done for your neighborhood in bettering the social, educational and financial condition of the farmers, in elevating the standard of living, in developing the spirit of co-operation, in improving the methods of farming and creating a love for pure-bred stock.

We hear a great deal of the legislative features of the grange. We are proud of its splendid work in that line; but a far greater work has been done in developing the latent possibilities of the members. Some one has said that "the universe struts around under the hat of every man," which is only another way of saying "the kingdom of God is within you." What is your grange doing to develop this kingdom or universe in every man or woman? That is the pith of the matter; that is what readers want; that is what anxious readers outside of the order are asking.

REPORT OF THE COMMISSIONERS OF EDUCATION

The two volumes of the above report have reached us. Both are replete with matter of great value to every lover of education. Indeed, no library is complete without this work, compiled and edited by Dr. Harris. There is no department of our government doing better work, or one that is more comprehensive and far-reaching than is that under the supervision of Dr. Harris. To those who know his career, who realize his magnificent service to the country, this goes without saying. The two volumes before us are a fitting example of his untiring industry to render our educational system the best in the world. Every grange should add these two volumes to its library. If you have no library, then let these form the nucleus of one. They may be obtained free of charge by addressing the Bureau of Education, Washington, D. C.

The "Monograph on Higher Education," by Dr. Harris, should be read by every young man and woman who is trying to decide whether it will pay to go to college or not, and by those who think education does not pay. This is also free. Mention the FARM AND FIRESIDE when asking for either of these.

**IT BEATS THE BUGS**

No matter if you have a dozen other sprayers, you will find use for this one. Every farmer, gardener, fruit or flower grower and poultry-keeper should get our

**Vapor Gem Sprayer**

Not so large as some, but the handiest of all. Tank and pump of heavy copper. Will last 20 years. One loading sufficient for an acre of vines. Regular price, \$2. Order immediately and get reduced price, \$1.50, express prepaid. Also agency. Send P. O. order for one now. **WRITE TODAY.**

**FIELD FORCE PUMP CO.,**  
 26 Market St., LOCKPORT, N. Y.

**SPRAY Your Fruit Trees and Vines**  
 24 styles spraying outfits. Best and cheapest. For prices and full treatise on spraying all Fruit and Vegetable crops address **WILLIAM STAHL, Quincy, Illinois.**

**GREGORY'S SEED CATALOGUE FOR 1900**

Get ready for good crops by settling the seed question right first. Gregory's seeds are sold on their merits as profit makers. They are home grown, hand selected, scientifically tested. If you want the finest crops your ground can give, get

**GREGORY'S SEEDS**

Warranted as per catalogue. Include many novelties for vegetable and flower gardens. Year book for 1900, an invaluable help to all growers. Yours free for the asking.  
**J. J. H. GREGORY & SON, Marblehead, Mass.**

**Burpee, Philadelphia.**

A postal-card, addressed as above, with your own address plainly written on the other side, will bring, by return mail, entirely without cost, a copy of

**BURPEE'S FARM ANNUAL FOR 1900.**

This is a bright book, full of faithful illustrations and true descriptions of the **BEST SEEDS that Grow**—which are sold direct to the planter without any middle-man's profit. Interesting and instructive new features for 1900.

**A Good Sign**

for a good garden in 1900 is to plant Maule's Seeds. Maule's Seeds lead all, have done so for years and are as far ahead as ever in the race.

**PLANT MAULE'S SEEDS**

in 1900 and have the finest garden in your neighborhood. Our new catalogue, is the best seed book of the year. It contains hundreds of illustrations, four colored plates, up-to-date cultural directions and offers \$2,500.00 in cash prizes. It is free to all. Write for it to-day. Address,

**WM. HENRY MAULE, PHILADELPHIA.**

**FOR 14 CENTS**

We wish to gain this year 200,000 new customers, and hence offer

1 Pkg. City Garden Beet,	10c.
1 Pkg. Earliest Emerald Cucumber,	15c.
1 " La Crosse Market Lettuce,	15c.
1 " Strawberry Melon,	15c.
1 " 13-Day Radish,	20c.
1 " Early Ripe Cabbage,	10c.
1 " Early Dinner Onion,	10c.
3 " Brilliant Flower Seeds,	15c.

Worth \$1.00, for 14 cents.

Above 10 packages worth \$1.00 we will mail you free, together with our great Catalogue, telling all about **SALZER'S MILLION DOLLAR POTATO** upon receipt of this notice and 14c. stamps. We invite your trade, and know when you once try Salzer's seeds you will never do without. \$200 Prizes on Salzer's 1900—rarest earliest Tomato Giant on earth. F. 156.

**JOHN A. SALZER SEED CO., La Crosse, Wis.**

**EVERGREENS.**

Largest stock in America, including Colorado Blue Spruce and Douglas Spruce of Colorado. Also Ornamental, Shade and Forest Trees, Tree Seeds, Etc.

**R. DOUGLAS & SONS, Waukegan, Ill.**

**THE BEST ASPARAGUS**

the kind that shoots white and stays white as long as fit for use is the **Columbian White** variety. Vigorous, strong grower and profitable for market. Ask about our earliest of all Victor Peas. Over a million trees of 60 varieties. Plum and Apple Trees, Strawberries, etc. Catalogue Free.

**Harrison's Nurseries, Box 28, Berlin, Md.**

**850,000 GRAPE VINES**

100 Varieties. Also Small Fruits, Trees, &c. Best rooted stock. Genuine, cheap. 25 sample vines mailed for 10c. Descriptive price-list free. **LEWIS ROESCH, Fredonia, N. Y.**





## A DAFFODIL LUNCHEON

THE gay daffodils with their petals of gold are here again to welcome the spring. Instinctively they gladden our spirits. We decided to invite a few of our most congenial friends, have the golden-hearted flowers to decorate our home, and dispensing a cordial hospitality, enjoy together a sunshiny hour or two.

A cluster of the yellow flowers were tied to the door-knob. Within ropes of ground-pine wound the staircase in the hall, and a tall vase of the flowers was placed on a small table which had a white linen cover. In the cozy, old-fashioned sitting-room where the guests were received long ropes of the pine were quite gracefully festooned from the corners of the room to the hanging-lamp in the center, where they were tied with yellow satin ribbon and clusters of daffodils. It is not very difficult, and the effect is excellent. Potted plants, the family favorites, which had survived the winter creditably were used to bank the mantel.

One of the wide window-seats in the dining-room held baskets of wood-flowers, which are abundant here, while a tall vase lavishly filled with daffodils occupied the other. Long vines of myrtle were trained around the pictures and outlined the table. Many daffodils arranged in a low, round glass vase formed the centerpiece of the luncheon-table. This was a twofold joy, for besides the bright decoration the guests were invited to guess the number of flowers the vase held, the fortunate winner receiving the bouquet.

As a bit of mental sunshine a souvenir was planned, and placed beside each guest's plate. On these, neatly printed, appeared James Whitcomb Riley's "Just Be Glad:"

O heart of mine, we shouldn't  
Worry so!  
What we've missed of calm we couldn't  
Have, you know!  
What we've met of stormy pain,  
And of sorrow's driving rain,  
We can better meet again  
If it blow.

We have erred in that dark hour  
We have known;  
When the tears fell with the shower,  
All alone—  
Were not shine and shower blent  
As the gracious Master meant?  
Let us temper our content  
With His own.

For we know not every morrow  
Can be sad;  
So forgetting all the sorrow  
We have had,  
Let us fold away our fears,  
And put by our foolish tears,  
And through all the coming years  
Just be glad.

After the luncheon the hostess and guests devoted a merry hour to learning these verses, for never a one was allowed to say "good-by" until she could correctly recite the poem. May it prove a golden memory to the happy-faced girls.

### MENU

Cream of Corn Soup.	
Salted Peanuts.	Peach Pickles.
Panned Chicken, Giblet Sauce	
Whipped Green Grape Jelly.	
Mashed White Potatoes.	Creamed Peas.
Egg Salad.	Cheese Sandwiches.
Vanilla Ice-cream.	Sunshine Cake.
Oranges.	Bonbons. Coffee.

**CREAM OF CORN SOUP.**—Add two cupfuls of boiling water to one canful of corn, one half teaspoonful of salt; simmer twenty minutes. Cook thoroughly together two tablespoonfuls of flour and two tablespoonfuls of butter; add a pint of hot milk, season with one half teaspoonful of salt, a little pepper, a slice of onion, and add this boiling hot to the corn; add a cupful of popped corn to one cupful of whipped cream. Serve the soup hot, adding the above garnish.

**EGG-BALLS.**—Thoroughly mix until smooth the yolks of two hard-boiled eggs, one raw yolk, a little salt and pepper. Add sufficient flour to roll out half an inch thick, divide it into squares, and roll into ball-shape. Poach in boiling salted water. The egg-balls are sufficient garish. Lightly browned wafers accompany the soup.

**PANNED CHICKEN.**—Wash, wipe, and split down the back. Rub with lemon-juice, then with butter and sifted crumbs. Spread bone side down in a buttered drip-pan. Cover two thirds their depth with water, sift over

a teaspoonful of salt, and dust with white pepper; cover the pan, and bake three quarters of an hour. Then remove the cover, and baste every ten minutes until nicely browned. Garnish with slices of lemon, and serve with giblet sauce.

**WHIPPED GREEN GRAPE JELLY.**—Whip a glassful of jelly until light and foamy, fold into it the white of an egg which has been beaten until light and dry, and dust with a little powdered sugar.

**EGG SALAD.**—Mash the yolks of six cold hard-boiled eggs thoroughly with two tablespoonfuls of minced veal or lamb, two tablespoonfuls of cream, one tablespoonful of melted butter, one fourth of a teaspoonful of salt, a dash of white pepper. Make into small balls, arrange on lettuce or cowslip leaves. Pour over this dressing: Place a teaspoonful of salt in a very cold bowl, rub with a slice of onion, add one quarter of a teaspoonful of pepper, a dash of cayenne, add slowly six tablespoonfuls of oil, two tablespoonfuls of vinegar, and beat thoroughly with a fork until thick. Garnish with rings of whites of eggs. Serve immediately.

**CHEESE SANDWICHES.**—Cut white bread into very thin slices, and spread each with a little good butter. Over half of the slices spread a liberal allowance of rich cream-cheese grated and highly seasoned with pepper, press carefully together a slice of each variety, and cut into the desired shape, which is always small.

**SUNSHINE CAKE.**—Beat thoroughly the yolks of five fresh eggs. Beat the whites of seven eggs about half, add one third of a teaspoonful of cream of tartar, then beat until very stiff. Stir in lightly a cupful of granulated sugar (which has been sifted several times), next the beaten yolks vigorously, add two thirds of a cupful of flour (previously sifted three or four times, then measured), a "pinch of salt and vanilla flavoring. Bake at once.

Do not attempt too much. Unless you are an experienced cook refrain from serving novelties to your guests. Practise on each dish until you are "letter perfect." Have the linen immaculate and exquisitely ironed, with china, silver and glass irreproachably neat. While white and gold china or white and green are particularly appropriate, use whatever you have with a heart and face as bright as these golden spring flowers. Place the knife at the right of the plate, with the sharp edge turned toward the plate, forks at the left, napkin folded square at the extreme left, the water-goblet at the upper right hand, and the soup-spoons at the right of the knives.

If you possess not the two-handled bouillon-cups serve the soup in small teacups. This course may be placed on the table and the goblets filled with cold water before the guests are seated.

All the dishes and silver pertaining to one course should be removed before the following course is served.

ADELE K. JOHNSON.

### ITEMS GLEANED AT THE EXPOSITION

Many trips to the exposition of the wide West, during the summers of 1898 and 1899, have proven to the writer very valuable in many and divers ways; and a few items there gathered may also prove of interest and value to the readers of these columns. Living within one hundred miles of the city of Omaha, Nebraska, it has been possible to visit the exposition grounds and buildings frequently with but small expense, and, as I said, the trips have in many ways proven educational and valuable, as well as pleasant and entertaining.

The present intention is to dwell especially upon such topics as will interest the housewife most, and I will turn first to the great hall where cookery of every description was carried on upon an extensive scale, and where the housewife was privileged to watch and question to her heart's content; also to sample the dainty and toothsome viands prepared by skilled artisans. To be sure, the general object sought was the advertising of certain brands of goods, but one was not obliged to purchase, though a great many did, and greatly to their own benefit. "Pure foods" only were on sale, and ways of preparing foods to a nicety were demonstrated.

In one especial booth a famous cook presided—a man white capped and aproned,

spotlessly clean and very neat in appearance, quaint and queer in manner, quite conceited in his skill, but one of the most thoroughly enlightened and systematic of workmen; and the dexterity with which he handled spoons, baking-dishes and batters surpassed all past belief. His conceit was of a forgivable nature, for he was so entirely worthy and proficient. And though he mimicked women in general, none felt to condemn him, but all found it worth their while to watch him and to adopt his many improved methods (and evidently to sample his wares).

A large gasoline-range with a capacious oven of very best make was in use, and the kitchen was a model in every particular. Granite and earthen ware bake-dishes and mixing-dishes were everywhere in evidence. The article under especial advertisement in this department was a certain brand of baking-powder, known to be pure and healthful, and of the best to be found. Gems and muffins, light, flaky, tender and "done to a turn," were constantly before one in some form—in the batter, in the oven, or finished and ready to be given out to any who wished to taste them from over the counter.

"Ladies," said our entertainer of the cap and apron brigade, "in the first place many of you doubtless are guilty of purchasing inferior baking-powder. Good cookery or healthful, wholesome cookery from such stuffs you can never have. But give you the best of baking-powder, and other materials likewise, I'll warrant that any number of you can ruin the whole thing, and do ruin your batter cookery, by handling ingredients and the compounded materials in a wrong manner. A woman is never content with giving a batter a good, sound beating once. But she must keep at it, at intervals, and she beats the lightness and the good all out of it before she gives the oven-heat a chance to get in its work. Her gems and muffins are tough and leathery, and she wonders what ails 'em. She has stirred and beat 'em to death! That's what's the trouble! This is the way you do it! Now, isn't it? You watch and see!" And suiting the action to his words he gave a vigorous beating motion to the batter before him, that he has already in exact shape for the oven. (But he does not touch the batter. To do so would be to ruin it, he says. The action is all pantomime. But he mimics to perfection the beating of batters by the average, unskilled, untaught cook.)

Our cook has measured all ingredients accurately for his muffins. There are two eggs beaten until very light, a half cupful of butter and lard mixed and slightly melted, and a pint of sweet milk, half a teaspoonful of salt, and three teaspoonfuls of granulated sugar. The flour was not measured exactly, but enough flour was used to make quite a stiff batter, and through the flour was sifted several times three teaspoonfuls of baking-powder. When the flour and baking-powder were added to the other ingredients it was all rapidly and thoroughly beaten until the batter was smooth and puffy. But the moment he stopped beating no further agitation was allowed. "Not another beat," he said, "on your life." And with spoon and knife the batter was taken up and scraped off into the hot gem-pans, and immediately consigned to the oven. There is but one effervescing of the baking-powder, and that immediately after coming in contact with moisture. If the second stirring or beating of a batter is given the effervescing qualities of the powder are dispelled, the batter becomes sodden and heavy, and the baked article proves disappointing. Many understood as they had not seemed to understand before the necessity of care in the putting of ingredients together, and in beating the batter only once, but very thoroughly that once. Not long, but thoroughly.

"And I'll warrant not one in ten handles pie-crust in a right way," said our cook. "I'll show you how. If you know a better way, show me how." And sifting two pints of flour into a mixing-bowl he added a teaspoonful of salt and a cupful of chilled lard. With a chopping-knife he chopped the flour and lard together until it was all in granular form. His fingers did not touch the mixture. Adding very cold water, sufficient to wet it all together, but in crumbly shape, it was poured out onto a well-floured board, scraped together with a broad knife-blade, gently rolled, and again scraped together into a cone-shaped pile in the middle of the board. This operation was twice repeated, when it was cut into pieces suitable in size for the pie-tins. Gently rolled and fitted to the tins, filled with a popular brand of mince-pie "timber," and baked to a pale, pretty brown, never were more delicious pies, with flakier, more tender crust, "set before (even) a king."

And not once had the hands been floured

in the operation. It is a dainty way, and a way worth practising to perfect.

At other booths in close connection at kitchen hall presided producers and dispensers of griddle-cake hospitality, pure maple-syrups, rich coffees and cocoas and chocolates, and many more of those elegant and healthful viands and concoctions that go so far toward making of home a home in reality. Young girls and housewives are taught there to cook, to preside, to serve, and to keep house after the most approved and sanitary methods. Housekeeping and home-making are beautified and devoided of so much of the old-time routine and monotony, and the housewife is shown a queen in her own kitchen realm. The best ways, the best goods and the best good to a worldful of home-folk are made easy of accomplishment, and the visitor finds herself so highly entertained and instructed, turn where she may, at the Greater American, that she desires to remain indefinitely.

Of the Filipinos in their villages and homes I shall be tempted to tell you later; for I found them far surpassing my most sanguine hopes or expectations of them, in all respects, and was quite tempted to take up my abode with them, and to learn also of their cookery, their serving, and their home manner of hospitality. Perhaps I shall later.

LYNN LANGLOIS.

### DRIED-APPLE DELICACIES

Having had a generous supply of dried apples given me by one of my parishioners I began seeking different methods of using them, so as to disguise the fact as much as possible that they were only "dried apples." Behold the result:

**FRUIT CAKE.**—Two cupfuls of dried apples; soak over night. In the morning chop fine and boil an hour in one cupful of New Orleans molasses. When cool add one cupful of sweet milk, one heaping teaspoonful of soda dissolved in a little hot water, one small cupful of butter or sour cream and three heaping cupfuls of flour; raisins may be added if liked. Season with all kinds of spices, and bake in a slow oven.

**DRIED-APPLE JELLY.**—A nice firm jelly can be made from the juice in which dried apples have been cooked. Strain the liquid, and to every pound of it add three fourths of a pound of sugar.

**APPLE CRACKERS.**—A dessert quickly made. Toast large, square crackers, put a tablespoonful of apple jelly on each one, whip some cream, flavor it with vanilla, and pile over the jelly. Dried apples and raisins cooked together are good, and they are better when cooked with "baby" green gooseberries, but best when cooked with young green currants.

**DRIED-APPLE CUSTARD PIE.**—Stew nice dried apples until just done. Line pie-tins with crust and put in apples with as little juice as possible. For three pies take three eggs, one and one half cupfuls and one pint of milk. Make a custard of the yolks and the milk, pour over the eggs and apples, and bake. While baking beat the whites with the sugar to a stiff froth and put on the top; when done set back in the oven, which should be rather cool, until sufficiently hardened. Flavor with lemon.

**APPLE DANDIES.**—Cook the dried or evaporated apples until almost tender. Cut as many squares of bread as you desire, place a spoonful of the apples and a teaspoonful of jelly on each slice, arrange on an earthen pie-plate, sprinkle the apples thickly with sugar, and strew over the whole grated coconut. Cover closely, and bake in a moderate oven. Serve with whipped cream.

**APPLE GEMS.**—Put into the sieve one half pint of flour, two thirds of a cupful of sugar, one teaspoonful of soda and two teaspoonfuls of cream of tartar, and sift into a pan. Rub into the flour thus prepared one third of a cupful of butter, and add enough water or milk to make a rather stiff dough. Roll out into a sheet one third of an inch thick, and cut into cakes half of an inch in diameter. Drop each cake upside down into a saucer of granulated sugar, pressing down a little so as to give an even coating of sugar, and put the cakes into a tin with plenty of space between. When they are wanted split each cake through the center with a sharp knife and spread with apple jelly.

**DRIED-APPLE SWEET PICKLE.**—Soak the apples over night. In the morning boil in this same water half an hour. Put into a colander and drain. Take half as much sugar as fruit, and enough vinegar to cover. If vinegar is too strong dilute it. Use all kinds of spices as desired. I find these pickles very nice this spring, especially as my other pickles are almost gone.

ELLA BARTLETT SIMMONS.



**WOMAN'S CLUBS IN THE COUNTRY**

There is certainly no doubt but that a woman's club in every country community would be a new evangel of womanly progress and enlightenment. For wherever club education is made a supplement to home-life its value cannot be overestimated or its influence ignored.

But like all schemes for the betterment of humanity, the woman's club has its enemies, who are pleased to assert that there can be no real good in anything that stimulates in women an interest in anything outside her own home-life. And from this we must assume that the real object of the woman's club has not yet been made plain to its detractors.

While the woman's club assumes that home-making is the sacred birthright of womanhood, and the club education that does not result in a broader and higher conception of the duties and responsibilities of home-life is a dismal failure, it also emphasizes the fact that women owe a duty to themselves which they cannot ignore without endangering the best interests of the home and the future welfare of the nation.

The influence of club education has been first to cause woman to understand her needs and limitations and to impress more fully upon her mind the helpfulness of intellectual culture in maintaining an ideal home-life; and then by bringing her into intimate association with other women, and putting her in touch with outside influences, and by intelligent discussion, to teach her the better to perform duties of womanhood.

In isolated country homes women are more liable to grow narrow and morbid because of the lack of intellectual stimulus and the inspiration of social intercourse, and every one must admit that all the good that accrues to the city woman through the influence of club education would just as surely benefit the country woman, and to a greater degree because of her greater limitations.

But the question arises, Are woman's clubs practicable or even possible in the country? And to this question we would reply that they are not only practicable and possible, but that in many country communities they are an established fact.

In almost every country community there are women who do hunger and thirst for a broader outlook and higher intellectual privileges. And country women as a rule are not slow to avail themselves of every opportunity which presents itself for self-culture and intellectual advancement.

Country women oftentimes stay at home and grow dull and morbid simply for want of a definite object to take them outside their own door, and this object has already been found in many farm communities in the woman's club.

In nearly every country neighborhood there are broad-minded and progressive women who are capable of organizing and maintaining a successful woman's club, and when once the dormant faculties are aroused there will be no lack of the interest and enthusiasm that always carries any organization to a successful issue.

In organizing any kind of a club it is well to bear in mind that there are always some impulsive spirits that must be held in check by a code of rules and regulations, and a knowledge of parliamentary rules is something that never comes amiss to any progressive woman.

There is no lack of interesting topics for discussion, but "Current Events" and "Household Economics" are always profitable and interesting. Then there are "Child-Study," "Co-operation of Parents in the Training of Children," "Twentieth-Century Home-Makers," "Books That I Like, and Why I Like Them," "Hygiene in the Home," "How Women Can Best Help Women," "The Philippines," "Cuba," "The British-Boer War," and many more subjects that will suggest themselves.

It will be found that instead of drawing women away from home interests the influence of the club will be for the betterment of the whole household. It will tend to develop more careful thought as to home-life, and insure a more thorough understanding of the conditions that make for the health and happiness of the family and the ideal home.

And, too, when the life of the country woman is no longer bounded by the narrow environment of the wood-lot on the one hand and the corn-field on the other, there will be opened a sphere of life beyond the furrow and the field and the succession of the seasons, labor will be dignified with a new meaning, and life will take on a new color and beauty.

And who shall say that the intellectual development, the culture and the inspiration of the broader, higher life will make the

women of to-day less worthy to bear and rear the children that will go forth from our homes to make or mar the future of our nation?

LIZZIE CLARKE HARDY,

**SOMETHING ABOUT MEATS**

There are two kinds of meat that are not fully appreciated by the average house-keeper. They are pork and mutton. Few meats are so susceptible of being treated in a variety of ways, are so nutritious, and go so far as mutton. The difficulty with this meat is usually because it is not hung long enough. I never let a winter pass without having two or three saddles of Canada mutton which have hung one hundred days. It should be daubed with a paste made of flour and water, so as to protect it from the air, and hung where it will be kept cold.

Cook it rare, baste carefully, and serve with a jelly gravy made as follows: Melt a cupful of grape or currant jelly, and slowly add a tablespoonful of butter. Let it come to a boil, and add a tablespoonful of sherry wine before serving. There are few dishes that can compare with this.

All mutton should hang at least eight or ten days; it then seems to lose that stringy quality, which is so unpleasant. Remember that the strong taste is in the fat, so that it is desirable to trim much of this away. Stand the leg of mutton on a rack or couple of sticks when you put it in the pan; this will keep it from cooking directly in the fat. There seems to be a curious connection between some meats and some vegetables.

Turnips are the usual accompaniment of mutton. An especially nice way to serve them is baked. Boil and mash them, then put them in a baking-dish mixed with bread-crumbs which have been soaked in cream. Scatter dry crumbs over the top, and bake for a few minutes in the oven.

Besides the saddle, the crown roast and the leg, the shoulder makes a nice dish. Have the bone carefully removed, and fill in the opening with a stuffing made as follows: One cupful of bread-crumbs, one egg, twelve oysters, juice of a lemon, two tablespoonfuls of butter, salt and pepper to taste. Sew up the opening; roast quickly, basting often.

Boiled mutton is much esteemed, and a tough leg may be treated this way, as the long, slow cooking breaks down the meat fibers and makes it tender. Caper sauce is tasty with a boiled leg, or a cream sauce with chopped cucumber pickles and parsley is equally nice.

A ragout is made from the neck cut into pieces about an inch square. Take one and one half pounds of meat, one tablespoonful each of butter and flour, an onion, a carrot, one half canful of peas, parsley, one or two cloves, and pepper and salt. If you want it very nice one and one half cupfuls of soup-stock may be added. If not at hand water answers very well. Melt your butter in a frying-pan, add the flour, and let it brown. Chop up the onion, carrot and parsley, and add them to the meat. Cook them for about twenty minutes in the butter, seeing that they do not burn. Then put in your stock and seasoning herbs, cover, and let them simmer for twenty minutes more. Add your peas about ten minutes before taking from the fire.

There is a delicious way of serving chops for luncheon, called a la Russe. Have your chops cut over an inch thick and left on the bone. With a sharp knife split them open, and spread inside the following mixture: Four tablespoonfuls of chopped mushrooms, one teaspoonful of chopped parsley, salt and pepper to taste; moisten with three tablespoonfuls of stock, and cook in a frying-pan with one tablespoonful of butter and one tablespoonful of flour well browned. Do not put the mushroom mixture in the chops till it is cool. Broil the chops a delicate brown, and serve with olives.

Since we have been reading so many Scotch novels the past few years we have heard often of Scotch collops. They are made as follows: Take thin slices of mutton, season them with pepper, salt, sweet herbs, a little onion and bread-crumbs. Put them in a frying-pan with butter, and fry brown. Then add chopped mushrooms, bacon cut small, and bits of sweetbread; fry brown, and serve. Truly a savory dish!

The persons who kill and treat their own pork have long known what a savory addition the sparerib, cracklings and other esteemed parts make to a winter diet. The city dweller is coming to understand, too, since pork comes in such appetizing form, all carefully protected in oiled paper. It is an easily digested meat if thoroughly cooked, but pork should never have the slightest tinge of pink, even in its innermost slice, when served on the table. Among many other ways of treating the leg may be men-

tioned the ham cooked fresh, not pickled or smoked. These fresh hams taken from a young pig, with the skin left on and carefully scored, make such delicious eating that one no longer wonders at Charles Lamb's eulogies. The tenderloins split and broiled are very nice for breakfast, while the very latest fad among our doctors is prescribing fat salt pork delicately fried and eaten, meat and gravy on a baked potato, for "brain-fag." Nobody has nervous prostration any more; "brain-fag" has taken its place.

It is said that a tablespoonful of the fat of fried salt pork has twice the nutritive value of the same amount of cod-liver oil. However that may be, it is a much more palatable way of taking nutriment. There are several ways of making hogshead cheese, a very delicate relish for tea or lunch. Many people are deterred from making it because they have got the idea that it is so much trouble. It is one of those dishes which must be made at home to be entirely satisfactory, and the following receipt, from an old Southern note-book, has always proved successful: Boil the head till quite tender, then loosen and take off the skin carefully, breaking it as little as possible. Keep it warm till it is wanted. Separate the meat from the bones, leaving out some of the fat if there is a great deal of it, and add the tongue and brains. Chop it all very fine, season with two teaspoonfuls of salt, three teaspoonfuls of black pepper, and four teaspoonfuls of allspice. These are the quantities for a moderate-sized head. Lay the skin on a towel, put the mince-meat on one half of the skin, and cover it with the other. Tie it up, and press it under a heavy weight for three or four days. The meat must be chopped quickly and put to press before it gets cold.

N. M.

**DIRECTIONS FOR MAKING CRAPE-PAPER LAMP-MATS**

While reading the FARM AND FIRESIDE to-day I saw Mrs. W. H. C.'s request for instructions for making crape-paper flowers, and as I did considerable work of that

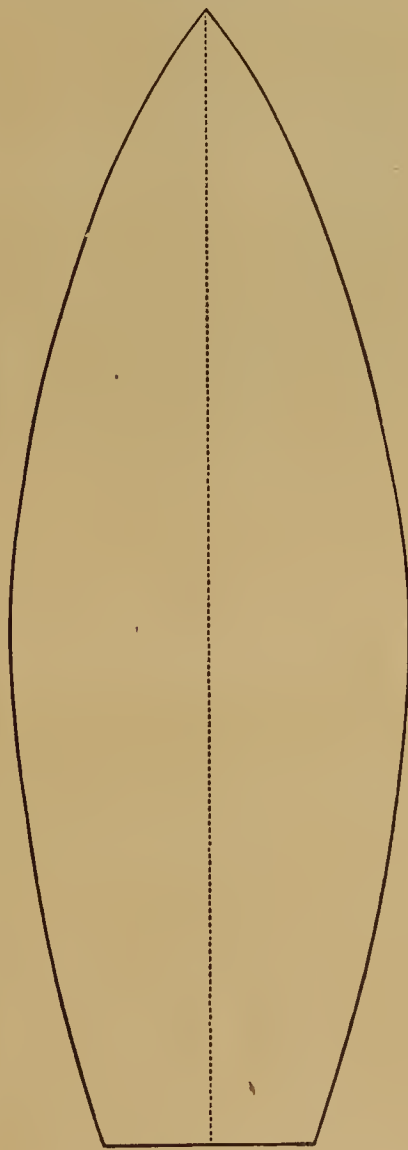

character during the holiday season, I may be able to give some helpful suggestions on the subject.

You may use all one color if you prefer, but I think I like the mat of one color and the lilies of a contrasting one. Make the mat of green, for instance, and white lilies, and you will have something which will be the envy of all your lady friends who are fortunate enough to behold it.

First cut a piece seven inches wide and the whole length of the roll of paper, then cut one five inches wide the same length. Cut about sixteen strips eight inches long and two inches wide, fold them together, and fasten with a bit of mucilage, so the joining will come on the under side of the strips. Now weave these together "basket-fashion" until you have a piece eight inches square. Next gather your ruffles very carefully, and

baste them around the center of the mat and stitch on the machine, securing the ends of the ruffles with a bit of mucilage, and leaving a half-inch heading on the last one.

Now you are ready to make your flowers. First cut five wires about eight inches long, and cover them over half the length with tissue-paper the exact color of your flower. Let it dry, and then paste to the back of petal on dotted line. Now cut five wires three inches long, and cover with yellow tissue-paper; place these together and tie firmly, then bend your petals slightly, like the natural blossoms, and place them around the yellow-covered wires which form the center. (Use five petals for a flower.) Now cut two or three long, slender leaves of green and fasten them to the back of the lily before covering the stem. Place three flowers on each corner of the mat, and you will be delighted with the fruit of your labor.

Of course, one must be careful to place the pattern straight with the grain of the paper when cutting, and pull out the center of each leaf slightly wider before finishing them.

MRS. C. B. P.

**"CHERRY RIPE"**

In olden times the cherry was an emblem of inconstancy, and for one to dream of it was ill luck indeed. We of to-day, discarding such traditions, turn to it with a zest born of a springtime need for the tonic its juice furnishes us.

Some of the most delicious desserts known to modern culinary art are produced by its aid. The fruit and blossoms also lend themselves admirably to table decoration, and even the milliner does not despise their invitation upon my lady's head-gear, while the small boy smacks his lips in anticipation of cherry pie.

**CHERRY JELLY.**—Soak one half boxful of gelatin in one half pint of cold water, dissolve it in one pint and two tablespoonfuls of boiling water, add the juice of a lemon, one and one half cupfuls of sugar, and strain. When it begins to stiffen put a layer of jelly in a dish, then a layer of large cherries which have been freshly seeded by hand, and so on with alternate layers, the jelly on top.

**CHERRY PUDDING.**—One cupful of sugar, one egg, one cupful of milk, one large tablespoonful of butter, one teaspoonful of baking-powder, two generous cupfuls of flour and as many cherries as can be stirred in. Bake in a shallow dripping-pan.

**BREAD-AND-BUTTER PUDDING.**—Place alternate layers of buttered slices of bread and cherries in a well-greased baking-dish, allowing two layers of cherries and three layers of bread. Make a custard of four eggs and one quart of sweetened milk, and pour over the top. Sprinkle sugar over each layer of cherries; bake until the custard is set.

**CHERRY BLANC-MANGE.**—Stew one quart of cherries, using a cupful of water, mash and strain. Return the juice to the pan and add one small cupful of sugar. When it boils stir in three heaping tablespoonfuls of corn-starch wet with cold water. When thick pour into molds, let cool, and serve with cream and sugar.

**CHERRY FLOAT.**—Proceed as for blanc-mange, using half the quantity of corn-starch, let cool, add the stiffly beaten whites of three eggs, beat well, and heap in a glass dish. Serve with sweetened cream or cold boiled custard made from the three yolks.

MARY M. WILLARD.

**"ILKA MICKLE MAKES A MUCKLE"**

The "stitch in time" saves many a mickle as well as the proverbial nine stitches.

Clothing lasts far longer if the washboard is discarded and borax, naphtha soap or some other harmless detergent is used in the family washing.

White clothes can be cleansed precisely as well without boiling as with, and the former is a decided saving of fuel.

Learn the latest up-to-date methods of making toothsome and attractive dishes out of every least "left-over" of meat or vegetables.

Don't stay in any of the old ruts of cooking. It's expensive. There is almost no end of excellent dishes that can be made from cheapest cuts of meat, and delicious soups can be had without the outlay of a cent.

Sickness in the family makes an astonishing drain upon the muckles. Avoid it by learning the nutritive value of different foods, and then provide a wholesome and varied diet for your family.

Lay in a supply of canned vegetables, and during the late winter and early spring depend upon these, with lean meats, fish, eggs and milk, and taboo fat meats, pies and cakes.

KATHERINE B. JOHNSON.

[HOUSEHOLD CONCLUDED ON PAGE 19]



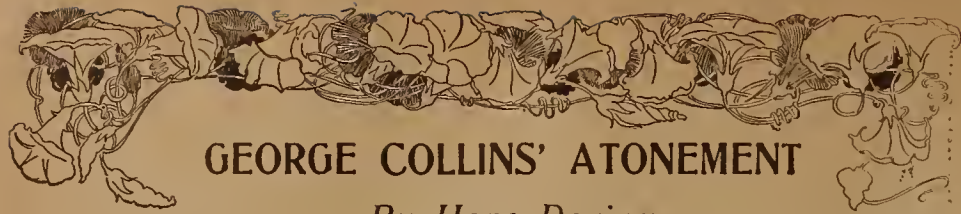

## GEORGE COLLINS' ATONEMENT

By Hope Daring

### CHAPTER V.

#### A NEW INTEREST IN LIFE



HE CAUGHT a glimpse of Bernice when he drove by the next morning. She was out in the yard gathering a handful of the blossoming nasturtiums, which a former tenant of the house had planted. After about an instant's hesitation he stopped his horses.

"Good-morning, Miss Slater. How is your mother?"

"Quite well, thank you, Mr. Collins. She slept well and is herself this morning."

"Ah, I am glad to hear that," and he chirruped to his horses.

"You are very kind. It is a beautiful morning, is it not?" Bernice said, the joyousness of the summer-time and of her own youth making her voice as sweet as the song of a wayside brook.

A rare smile lighted up the stage-driver's face. "Yes, it is a beautiful day, Miss Slater; a day in which all the earth cannot but be glad."

He looked back as he drove on, vaguely thinking she was a fitting accompaniment of the day. Arrayed in a simple brown gingham dress, her dusky head uncovered, and her hands filled with the glowing scarlet, golden and maroon blossoms, Bernice Slater made a picture fair to see. And as the lumbering old stage rolled on, up and down the hills, now in the warm sunshine, now in the shadow of the waving, growing boughs, George Collins was conscious of a new joy in life.

He saw little of his new neighbors for a time. The windows of the little brown cottage were brave with fresh muslin curtains and blossoming plants; he often heard in the twilight a fresh young voice singing old songs, and he sometimes saw a slender figure flitting about. That was all until the first Monday morning in September.

He was busy cleaning off his horses when a light step sounded at the barn door, and a voice said, "Mr. Collins, please don't forget to call for me this morning."

He dropped currycomb and brush and raised himself from his stooping position. It was Bernice, fresh and radiant as the morning.

"So your school convenes to-day. Well, I will be at the door promptly at half-past seven."

"Very well," and she tripped away, leaving him to his prosaic task.

When he drove up to the door of the brown cottage she hurried down the path, her arms filled with books. Her mother came close behind her, carrying a lunch-box.

"Now don't forget to make the children mind, Bernice, and do try to be dignified," Mrs. Slater admonished as George descended to assist her daughter into the stage.

The girl laughed merrily. "I'll remember, mama dear. Please, Mr. Collins, may I sit on the front seat with you? I can see out better, and I do not want to miss one bit of this lovely morning."

He consented, and they drove off, Bernice turning to throw kisses to the pale mother who stood to watch them out of sight.

Bernice's lips quivered a little. "Poor mama, she is so afraid I won't succeed!"

"But you will," George said. "I am sure, Miss Slater, you are one of the kind of people who succeed."

She looked thoughtful. "I hope so. Yes, I really think I am. Only, you see, I haven't as yet had much chance to try. It must be grand to be a man and know you have succeeded."

His face darkened at the innocent words. What was he, what was his life that he should speak of success? Then he resolutely banished these thoughts and listened to Bernice's quiet words of appreciation of the view of a tree-embowered lake that he pointed out from the brow of a hill.

They soon reached the little dun-colored school-house. Bernice drew a long breath.

"My Waterloo," she said, with a mock-tragical gesture.

"Then all depends on whether you are Napoleon or the Duke of Wellington," George replied, as he lifted her to the ground.

"Thank you," nodding archly. "I've decided to be the Duke;" and she ran lightly up the path. He found her waiting for him on his return trip. She was in excellent spirits, reporting her school as a quiet, orderly one.

As the days went by it became evident that Bernice was a successful teacher. She grew to love the children under her charge, and often amused George by her accounts of their brightness. Then she told him of her own school-days, and in turn listened to descriptions of places visited during his travels, or of life in a Colorado silver-mine. He even told her something of his newly awakened literary aspirations, and when his first story was accepted Bernice's delight was more outspoken than his own. They discussed books, and he loaned her freely from his library. When he learned that she was trying to teach herself German he offered to help her. So the German grammar came to be a companion during the rides, and when the stage had no other occupants the lessons went on merrily.

George Collins did not ask himself why life had grown so sweet to him. He accepted it all unquestioningly. Unconsciously to himself the

companionship of nature and of the glad-hearted girl, still almost a child, had wrought a wondrous change in him. He was learning to care for the world at large and becoming kind and helpful to those whom circumstances brought in his way.

His plan had been to return to Chicago for the winter. He thought of the cold days when Bernice must rise before daybreak and prepare for her ride, and he resolved to remain in Holland.

So October's beauty and glory faded into the grayness of November, and that gave place to the sleet and snow of December. The last night before the beginning of Bernice's holiday vacation was a cold and stormy one, the road being blocked by high drifts of snow.

It was dark before George reached the school-house. Bernice was watching for him at the window. It took her but a few moments to don her wraps and join him.

She was in a merry mood, and George, too, had his bit of good-cheer. Another story had been accepted. With the acceptance had come not only a liberal check, but also a few words of confidential appreciation, which meant much to the author.

Protected by the cover of the stage they talked on, unmindful of the storm. They were within a



"THEY SAT TOGETHER UNDER THE BEECH-TREE"

half mile of the village and were descending a steep hill when the horses stopped suddenly. George spoke to them, but they did not start.

"Ah, there is something wrong," and he started up. After pausing a moment to securely wrap the robes around Bernice he sprang into the snow. The darkness prevented his seeing just where he was. He took one step forward, lost his footing, and slid some distance down a bank.

In a moment he grasped the situation. The horses had left the road a few rods back, taking a narrow path from which the wind had swept the snow. This path skirted a high bank. There was no room to turn the team here, and a single misstep meant disaster. There was but one way.

Clambering up the steep descent he called, "Bernice, where are you?"

"Here, this way! What is wrong?" Guided by her voice he reached the stage. He lighted a lantern and explained the matter to her. To his great relief Bernice remained calm.

"What can I do to help?" was all she said. "Remain perfectly still. I will lead the horses to the foot of the hill. When we reach level ground I can trample the snow and turn them back into the road. Do not be afraid."

"I am not. I trust you," she replied, steadily. "Only be careful of yourself."

Very slowly George led his sure-footed horses down the hill. Death might be near, not only death for himself, but for the girl who had said, "I trust you." "And yet—death would find them together."

At last level ground was reached, and after much trampling of snow and many cheering words to the horses they were turned into the road. Then George again took his place by Bernice's side. He felt her hand clutching his arm.

"I understand all about your coolness and courage. Oh, if—"

"Don't let's talk about it," he interrupted her to

say. "It is over, and all is well. I'm most unromantically hungry."

"Come over and take supper with mama and me. Please do, Mr. Collins."

He promised, and the next moment drew rein before the post-office. The mail-bag was tossed out, and Bernice was soon at her home.

After carefully providing for his horses George entered the house. A coal-fire kept the rooms warm all day. He washed, and replaced his working-clothes with a neat black suit.

Bernice herself came to the door. "Don't tell mama," she whispered, warningly. Then she led him to the sitting-room, saying, "Come, mama, and entertain Mr. Collins. He is nearly famished, so I will hurry supper."

In a short time she called them to the tiny dining-room, where the table was neatly spread. The broiled steak, baked potatoes, crisp celery, baked apples, and home-made bread and butter were relished by the hungry travelers. Then Bernice cleared the table and brought on fragrant coffee, thin slices of rich, dark fruit-cake, and nuts.

This glimpse of pretty home-life charmed the guest. How sweet Bernice looked in her school-dress of wine-colored flannel, with a bit of soft cream lace at her throat! How dainty the rooms, although the furnishings were cheap!

When, at a late hour, George made his way to his home he was in a thoughtful mood. He began to see what all this meant to him. What did it mean to Bernice?

He sat for a long time before the fire. Had he read her face aright? Did she care? He knew now what had changed the whole world for him. Did his past debar him from happiness? Dared he strive to take this glad young life into his keeping?



"AS THEY CROSSED THE THRESHOLD HE STOOPED AND KISSED HER"

Suddenly he rose, a new light on his dark face. "I will bide my time. If she loves me and can overlook my past all is well. If not, I will go back to my rightful place in the world and be a man. I owe that much to the love which has awakened my better nature."

All through the winter and early spring the quiet, uneventful days sped by. There was but one cloud on Bernice's sky. Her mother's health was failing.

The end came quickly. One Saturday afternoon when George reached the village he saw the doctor enter the Slater home. A neighbor, who was passing, told him that Mrs. Slater had been taken suddenly and seriously ill.

George called a boy who was playing near to care for his team, and entered the cottage.

"Oh, Mr. Collins, I am so glad you have come!" cried Mrs. Traver, a widow who lived near. "She could speak a moment ago, and she called for you."

A moment later some one beckoned him to enter the room where the sick woman lay. Bernice was kneeling by the bed, her face pale and agonized.

"Here is Mr. Collins, mama," she said. Slowly the eyes of the dying woman opened.

"What is it, my friend?"

"Take-care-of—Bernice, dear Bernice;" and with the loved name on her lips the mother's soul took flight.

It was George's strong arms which lifted the bereaved daughter from her mother's pillow, and

his voice which said, in a tone that reached no ear but her own, "You are mine now, Bernice."

Every one turned to him for directions. Bernice's relatives were summoned by telegram, but before they arrived George felt that there must be an understanding between Bernice and himself.

He went over to the cottage early the next morning. Bernice was sitting on the back steps, her hands clasped listlessly in her lap, her eyes fixed upon the eastern sky, where the sun was beginning to color the clouds with gold and carmine.

He sat down beside her. "Bernice, I love you! Do you care for me?"

She clung to his outstretched hand. "You are all I have in the world, and all I want now that she is gone," she said.

His breath came fast. "But I am twice your age, Bernice, and my past is a dark one."

"I love you for what you are now. That satisfies me. I trust you, George."

He gathered her close in his arms, pressing his lips hungrily upon hers. "My darling, my darling! Oh, God, thou art good!"

That was all. He cared for her, he stood between her and every care, but he knew her heart was too sore for words. Two days later he accompanied her and the cousins, who had arrived, to the Slaters' old home, where Mr. Slater was buried, and where his relatives lived.

Soon all was over. George was to take Bernice back to Holland. No definite plans for the future had yet been made.

"Of course she can stay in the house awhile if she wants to," said Mr. Slater's brother, with whom George was talking about Bernice. Then, seeing the other's look of surprise, he asked, "Why, didn't you know she wasn't my brother's child? He was just her stepfather, so the property will come back to us."

On the way home Bernice spoke of this. "Mama had a small income of her own, but I think it ceased at her death. I never understood about it. The papers are all in the desk at home. Will you look at them to-night and see?"

"Certainly, if you wish. But, Bernice, don't think about money. I have enough for both."

"You?" and a look of surprise came into her solemn blue eyes. "I thought you were poor. It doesn't matter, though. We have each other."

Mrs. Traver was to close her little home and remain with Bernice for a time. When George had his betrothed good-night she slipped a packet of papers into his hand.

"These will tell you all about me."

He drew her to him for a moment. "All I care to know is that you are mine."

After reaching home he sat down and gave himself up to a contemplation of his future. He had already made arrangements for another to take his place as stage-driver. Bernice wished to finish her school. As for himself, he must hasten home and prepare the farm-house for the coming of his bride.

His hand came in contact with the papers Bernice had given him. He untied the package and opened a letter which lay upon the top. Starting violently, he opened another. On and on he read, his face growing ghastly. At last he paused and pushed the rest of the letters aside unread. There was no use of going further. His dream of happiness was over. Bernice was the daughter of William Kennedy, the man whose death he had unwittingly caused fifteen years before.

### CHAPTER VI.

#### SELF-MASTERY AND PEACE

For a long time George Collins sat with his head bowed upon the table. A breeze stole in at the window and lifted his hair, showing his brow headed with great drops of perspiration. In vain he was trying to still the tempest which was sweeping over his soul.

At last he sat up. Slowly he fought his way back to composure. Then he drew the letters and papers to him and went more carefully over them. Thus he was able to gather the facts concerning Mrs. Kennedy-Slater's life from the death of her first husband until coming to Holland.

It seemed that when in possession of the comparative competence with which George's generosity endowed her Mrs. Kennedy had aspired to better living. She must have abandoned her habits of carelessness, habits which were no doubt induced by her poverty. She remained in her little home for several years. During this time the boy, the youngest child, died. She then married Mr. Slater, and removed to his home. Each year she returned to Lamont and received the money forwarded by Mr. Larr, receiving it in her old name.

None of Mr. Slater's relatives had known the story of Bill Kennedy's death. Bernice had been too young at the time of this to remember the circumstances, and it was easy to see that her mother had done all in her power to obliterate the dim impression retained. Mrs. Slater had lavished both love and money upon her daughter. The girl had received a thorough education, this having been paid for with George's money.

He went thus far and stopped. The rest of the papers seemed to refer to the life of Mrs. Kennedy before Mr. Kennedy's death, and possessed no interest for him. He had learned enough.

There was but one thing he could not understand. Why had not Bernice's mother recognized him? The name was not uncommon, and the years had sadly changed him. At all events she had not. With her dying breath she had given him Bernice.

And now? Should he destroy these papers and take Bernice as his own? Must he renounce the sweet, new hope which had flooded his long-clouded life with sunshine? Ah, should he make her his wife the blood of her father would cry



out against the act! He had sought to atone for the past by the payment of money; now he saw that the way must lie through suffering.

For a time the old bitterness filled his heart. Why should he look for aught save sorrow? Why—and there rose up before him a memory of the glad, true life of the girl whom he loved. He recalled his past, and the future to which he had pledged himself. A great calm possessed his soul.

George Collins rose to his feet. "I will accept suffering, because I must. I may have to renounce happiness, but I will not renounce my new dream of a useful, noble life. Now my first thought must be for Bernice."

While Mrs. Traver and Bernice were at breakfast the next morning George entered the room. Both exclaimed at his haggard look, but he explained that he had not slept well, and was suffering from a headache.

"I have received news which will call me away to-day," he said, trying to speak in his usual voice. "I must start for Loyd this morning."

After a few moments Mrs. Traver excused herself, on the plea that she must run over to her own house and see if all was in order. The good woman understood that the lovers wanted a little time together.

Bernice came to George's side. "What is it, dear? Something is troubling you."

"Is it not trouble enough that I must leave you? Don't ask me why, Bernice. Trust me. You shall hear from me soon. Oh, little girl, you do not know what you are to me!"

The intense passion and pathos of his voice brought the tears to her eyes.

"Will you be gone long?" she asked, slipping one hand into his.

"I cannot tell. I will write in a few days and explain all to you. Until you hear from me, darling, will you trust me implicitly, and not let my reticence of this morning worry you? Poor little lonely child! Your lot is hard enough to bear."

He could not resist the temptation to take her in his arms. Clinging to him, she said:

"I will always trust you, George. And I will always love you. If years should pass before we meet, you would find me as you now leave me."

He lingered for a half hour. Ere he said good-by he placed in her hands the packet she had given him the night before.

"I have examined only a part of these. There is nothing of monetary value among them, but some matters to which I will give my attention later. Will you not put them away undisturbed until you hear from me?"

She assented unquestioningly. Then he rose to go. Would this be the last time his eyes would ever rest on her dear face? He grew faint with pain. Yet for her sake he must be calm.

"Good-by, my love, my life," he said, kissing her not with passion, but with something of the solemn tenderness with which he kiss his dead. "Oh, Bernice, Bernice, I would die to make you happy!"

"Live to make me happy instead," she said, softly, all her womanliness rising unconsciously to soothe his distress. "Remember how proud I am of you, and the work you are to do. Remember that it is my work, too, for our interests are one."

He could bear no more. One moment longer he strained her to his heart, then hurried from the room and the house.

Late that afternoon he reached the farm-house. Mr. and Mrs. Blake were still there. Years had not lessened the kind woman's volubility nor her care of George and his belongings. When she learned that he intended to remain permanently at the farm-house her delight knew no bounds.

Mr. Larr was a feeble old man, and George recognized, with a pang of self-accusation, the fact that his affairs had been a burden to this lifelong friend. Now he would take the place of a son to the lawyer. He would give the farm his personal attention, at the same time reserving a great part of his time for study and writing.

Collins farm was the pride of the community. There had been few changes in the house since the death of George's parents, only such as had been necessary to keep it in good repair. The master had planned extensive improvements before the coming of Bernice, but all these were abandoned. He went carefully over the farm. The growing crops were in excellent condition, the fences and outbuildings in order, and the pastures filled with sleek-coated Jerseys and Alderneys. There was a young apple orchard just beginning to bear. George resolved to put out a quantity of other fruit, and to also experiment with growing vegetables for next year's market.

Yes, it was a home of which any man might be proud. Should he say a home where any man might be happy? How happy he might have been there! Then the old determined lines came about his lips. Happiness was much; duty might be more.

For two days he wandered about the farm. Then he wrote to Bernice.

This letter was brought to Holland by the new mail-carrier, and taken to the brown cottage by Mrs. Traver. Bernice carried it up to her own little room that she might read it alone. It was the first letter she had ever received from her lover. A wave of crimson flooded her cheek as she pressed her lips to the address his hand had penned. Sitting down on the floor by an open window, she drew from the envelope a half-dozen sheets covered with firm, fine writing.

LOYD, May 7, 189—

MY DARLING:—I must now tell you something of my past, that you may understand what I have to say regarding our present and future. I have doubtless told you that I was twenty-three when I graduated from Andrus college. My heart was filled to overflowing with joy in life and living. Soon after graduating I went to visit a college friend, Stanley Hart by name. While there I

spoke at several political meetings. One evening while on my way out of the hall I was attacked by an infuriated opponent to the party for which I was working. In defending myself from his violence I gave him a blow which caused him to lose his footing. He staggered back and fell down an open stairway, near which he was standing, breaking his neck in the fall.

You can imagine something of what I felt. I was arrested and tried for manslaughter, but acquitted. Stanley, whom I considered my truest friend, proved indifferent in my time of trouble, showing me that his interest in the affair extended only to the effect it would have on his business and social standing, and the power it gave him to extort money from me. Then he had a sister, to whom I had been strongly attracted. I did not love her, but I thought then I did, and in my hour of darkest night she represented to me tender, compassionate womanhood. Upon being released I went to her, and while waiting for her to enter the room I heard her narrate to a girl friend how she had amused herself with me, and jesting about my misfortune. I see now that I was weak where I should have been strong, but I let this ruin my life.

Bernice, do you begin to see why I am telling you this? The place where all this occurred was Lamont, your mother's old home, and the man unintentionally killed by me was—William Kennedy, your own father. God knows I never dreamed of this, dearest, until I examined the papers you gave me.

Oh, my darling, how can I give you up? Would to God I had never seen you, for I have brought naught but sorrow and distress to you. As for myself, my beloved, I gladly bear the pain for the sake of what you have been to me. You have given me back faith in humanity, Bernice, and whatever my future holds of worth will be your work.

When you can, write me. Do not leave Holland without acquainting me with your plans. And, Bernice, as you love me, do not pain me by refusing the check I inclose. Mine is yours, dearest, and I cannot bear the thought that you must face poverty while I have wealth.

Once again and always, I love you, my darling!  
GEORGE COLLINS.

As she read on and on, strange, half-forgotten memories from her past came to her. She recalled the day of George's visit to her mother. She had understood that he was in some way connected with the death of the father for whom she had had more fear than love. The story of the money she had never comprehended, and her mother had refused to talk of the past.

The letter dropped from her hands. Prone upon the floor she sank, her face buried in her hands, while over and over she sobbed out the words, "He loves me! he loves me!"

Weeks went by and no word from Bernice reached Collins farm. This silence was very hard for George to bear, yet he felt that he had no right to address her. Whatever passed between them now must be determined by her. She could never be his wife, and meetings between them would be too painful for both. Still, might not she write him occasionally?

One morning early in July he was out in the harvest-field. The strong-armed cradlers had just cut a swath of wheat around the field, thus making a path in which the binder might commence its swift work. George sat down on the great gnarled roots of a beech-tree that grew on one side of the field, and lifted the coarse straw hat he wore from his heated brow. A slight breeze ruffled the surface of the sea of golden grain before him into long swells and waves. The same breeze awakened low, sweet music among the silver-green leaves above him, and the sunlight stealing down through the dense foliage cast quivering gleams of brightness at his feet.

George drew a long breath. How sweet and fair the world was! Why could not life be in accord with it? The old pain woke in his breast. Bernice—ah, she was life to him, and the barrier between them could never be leveled!

He heard a light step, and turned. Had pain and grief unbalanced his brain? For a few paces from him, the sunlight bathing her in brightness, stood Bernice. He stared helplessly, noting the exquisite neatness of her plain, black dress, the carmine of her cheeks, and the radiance in her eyes.

"No, no, it is not a dream!" she cried out, reading aright the dazed look upon his face. "It is a reality, dearest. There has been a mistake, a mistake which nearly ruined both our lives. George, William Kennedy was not my father!"

He waited to hear no more, but folded her in his arms. There was a long silence, both hearts were too full for words. They were together; that was enough.

After awhile, as they sat together under the beech-tree, Bernice told her story.

"I put the papers away as you bade me. When your letter came I—well, the hurt was too sore for me to care. Two days ago, as my school had closed, I was preparing to leave Holland. I opened the packet, and, George, the older papers, the ones you apparently failed to examine, told the story of my birth."

She paused a moment. He did not speak, but gently stroked the hand he held until she commenced again.

"The woman whom I loved so well, and who was so kind to me, was my aunt instead of my mother. She took me as her own child when my own mother, her sister, died. This was about the time of her marriage to Kennedy. Notwithstanding his dissipated habits and general worthlessness he doubtless used me as well as if I had been his own child. She—poor woman—loved me only second to her boy, and when she lost him all her affection was given to me. There are letters from my own father, who it appears was a man of education and culture. My name is neither Slater nor Kennedy, but Osborn."

"And it shall be Collins this very day," George cried. "Nay, nay, my love, do not shake your head. Think of the weary years I have waited for some one to love me."

"But, but," and her eyes sank before his, "I came to you. I might have written and waited for you to come for me, only I could not endure to have you bear the pain a moment longer than was necessary. Perhaps it was unwomanly—"

"It was heavenly," he interrupted her. "Come, let me take you to our home. I will send for the minister and Mr. Larr."

Still she hesitated. He looked straight into her eyes.

"I love you, Bernice!"

She hid her face upon his breast. "It shall be as you wish," she whispered.

So he led her through the sunny fields to the old farm-house. They passed up the walk to the porch, where the late pink roses still clambered. As they crossed the threshold he stooped and kissed her.

"Welcome home, my wife."

THE END

## THE CHESTNUT-FARMS OF ITALY

BY GEORGE E. WALSH

The Italian chestnut-venders who appear on the streets of our cities in the autumn to retail the new crop of nuts are picturesque reminders of the poor peasantry of Apennine Italy. There two or three thousand feet above the sea-level dwell a class of mountaineers who for ten months in the year live practically upon chestnut porridge and chestnut cakes. In the fertile valleys of Italy the grape, fig and olive thrive in abundance, but as you ascend the sides of the Apennines these delicious fruits make way for more hardy products of the soil. Corn, grain and potatoes flourish from one to two thousand feet above the sea-level, and then they grow small and useless because of the rigors of the climate. From this latter altitude up to the highest point that man can live with any degree of comfort the great chestnut-farms of Italy cover the mountain slopes and provide the peasants with most of their food.

The Italian chestnuts are larger than our native varieties, and they are imported into this country in considerable quantities. They have been grafted on our native stock successfully, and in recent years a great deal has been said about the extensive forests and farms of chestnuts in this country, but they compare poorly with the Italian chestnut plantations high up the sides of the Apennines. For miles upon miles the mountain-sides are clothed with nothing but the chestnut-trees. These trees are cultivated by the Italian peasantry just as systematically as their brothers in the valleys below cultivate the olive and grape. The trees are thinned out properly and allowed to develop under the most favorable conditions. All underbrush, except a little heather, is cleaned out every year, and one can walk under this canopy of chestnut boughs for miles without meeting any obstructing bushes or weeds. It is like a park, except that the ground is rocky and sloping in places, making it necessary for one to hold on with both hands.

The trees are divided up into farms without any visible boundary-line or fence, but each owner knows his own trees and never intrenches upon his neighbor's farm. The peasants do not as a rule own the land or trees, but simply cultivate them for landlords in the towns and villages. The peasants cultivate and collect the nuts for a share of them. As their share is barely sufficient to feed them the year round they realize very little money to buy luxuries of food or clothing. It is only the landlords' shares which go down the sides of the mountains, and eventually find their way to this and other countries.

The chestnut-trees grow naturally on the sides of the Apennines, and the trees never fail to produce a large crop. The destruction of one season's crop would mean death by starvation to thousands of the mountaineers if outside help were not given. How dependent upon the chestnuts these people are Americans who have not visited the place can barely realize. There is practically no other food raised on the mountain-sides at these altitudes except it be a few hardy varieties of potatoes and cabbages. But there is little room for these luxuries to thrive in, for soil is as precious up there as gold and silver. Every square foot of tillable soil is cultivated carefully, and rocky fences are propped up to prevent it from washing away. In the summer-time the peasants have a few vegetables that they raise in these small gardens, but from October to June they live upon chestnuts. The fall months bring a change of food to them, for then they can have fresh boiled chestnuts, which to the mountaineers are just as grateful as green vegetables and fresh fruits are to us at the close of winter. They have been living all winter and summer on their diet of chestnut porridge and cakes, with a few vegetables occasionally.

Such a diet is not very nourishing, and in spite of their outdoor existence the mountaineers look half starved. They always have plenty to eat, for so long as the chestnut flour or meal lasts they do not actually suffer. In October and November the peasants gather the nuts and boil them. They are either boiled in the shell and eaten as balotte, or hulled first and then boiled and seasoned with salt and fennel-seed. This mixture they call *tigliate*, and it is considered a great luxury. Another way that the fresh chestnuts are served is to pass them through a sieve after boiling, and serve them with whipped cream. Cream is so difficult to get, however, that this mixture is not common in the peasants' homes.

For the winter food the chestnuts are ground into a flour or meal, which can be kept indefinitely in the bins made of chestnut-wood. The nuts are dried and ground in a rude stone mill. It is the old-fashioned millstone that is used to grind the nuts, and the flour that is turned out is much coarser than our common corn-meal. This coarse flour is very sweet, and to one not accustomed to

eating it, it would be sickish to the taste. The flour is put away for winter use, and forms the chief staff of life for the family until another chestnut season comes around.

The flour is usually served as a porridge or in the form of cakes. The porridge is very simple. It is made by boiling some of the flour mixed with water in a copper kettle, seasoning it with a little salt. The mass is boiled down to a thick, stiff paste. Then it is poured out on a flat surface, where it cools, and then the housewife cuts it up into convenient pieces. This porridge is eaten hot when first made, but the remainder is eaten cold or warmed over, according to the pleasure of the cook. It is not a very agreeable diet, but the mountaineers like it and wash it down with copious draughts of mountain spring-water.

The other form in which the chestnut-flour appears on the table of the peasants is that of the cakes, or *necci*. In order to have this dish through the winter it is necessary to prepare for it in the fall. The chestnut-leaves are gathered in the woods by the children and strung on strings to dry. These leaves are used for cooking the *necci*. The manner of doing it is so primitive that it is interesting to a visitor. There is no cooking-stove such as the American housewife uses, but primitive slabs of rock are employed. These round pieces of rock, or tiles, as they are called, are first heated in the ashes of a fire. Then chestnut-leaves soaked in water are spread over them. Then the batter of chestnut-flour and water mixed to the proper consistency is spread over these tiles and another tier is built on top, with the layers of leaves and batter between. This process is repeated until the stack is large enough to satisfy the needs of the family. The tiles are stacked in the ashes of the fire, which is meanwhile stirred into a brighter glow, and then the cooking proceeds. The cakes are served hot as they are taken from between the tiles. As it requires only a few minutes for the cakes to cook there is not much waiting for a dinner served after this primitive style.

These chestnut concoctions constitute the diet of the Apennine chestnut-farmers, and they cultivate groves of trees to have this fare supplied in abundance. The few nuts they sell bring in money enough to enable them occasionally to purchase a few luxuries from the towns and villages. Chestnuts are considered very nourishing and digestible when eaten in moderation and with other food; but depended upon as the chief and sole article of diet they are not very beneficial. Most of the mountaineers have stomach disorders and indigestion, and a visitor could no more live upon their fare for any length of time than he could subsist upon the peculiar food of the clay-eaters. Americans may not eat enough nuts for their best welfare, but the Apennine chestnut-farmers eat too many. Circumstances, however, force them into this narrow diet, and habit has made them like it. Many an Italian mountaineer who leaves his home becomes homesick for his chestnut groves and fare, and longs for some of the *necci* or *balotte* that was supplied to him so liberally in his boyhood days. There is little wonder that, considering these facts, the Italians are the principal venders of chestnuts in New York and other American cities. They are never so much at home as when gathering chestnuts in the woods or roasting them by the street-curb for customers. The odor of the roasting nuts must carry them often back to their Apennine home where chestnuts have to serve as bread, meat, fruit and vegetables.—The Interior.

## THE SOUTHERN CROSS

"A halo of romance," says Miss Mary Proctor, in the "St. Nicholas," "has woven itself about the stars of the Southern Cross, one of the most picturesque objects in the southern skies. At one time these stars formed part of the constellation 'Centaur,' which was once included under that called 'Argo,' the Great Ship, but toward the end of the eighteenth century the Southern Cross became a constellation on its own account. Nevertheless its resemblance to a cross must have been observed long before this time, since an Arabian globe has been found on which an outline of a cross is marked about this group of stars.

"The longer bar of the cross points nearly to the south pole, the situation of which in the heavens is not marked by any brilliant star, but which is about four and one half cross lengths from the foot of the cross. For this reason Alpha and Gamma are sometimes called the 'Pointers.' In fact, the Southern Cross may be looked upon as the hour-hand of a great clock, which goes round once in twenty-four hours, moving in the same direction as the hands of a clock, unlike our Great Bear or Dipper in the northern heavens, which appears to go round the northern pole in a direction contrary to the hands of a clock. This is because the observer's face when looking at the northern pole is turned in a direction contrary to the face of an observer in the southern hemisphere turned toward the southern pole.

"Near the Southern Cross is an almost vacant patch of sky, which is named the 'Coal Sack' by early navigators. In the Coal Sack only one very small star can be seen with the unaided eye, but the telescope reveals many stars in that seemingly deserted region, proving that the striking blackness is due simply to the effect of contrast with the brilliant ground surrounding it on all sides. On the northern edge of the Coal Sack is a star of ruddy hue, known as Kappa, but too small to be seen with the unaided eye. Even a small telescope fails to make one realize the splendor of this star, but when Sir John Herschel turned his twenty-foot reflector in its direction he was surprised to find Kappa the center of a cluster of over one hundred stars of all the colors of the rainbow, contrasting wonderfully with one another. He compared it to a superb piece of fancy jewelry, while Flammarion describes it as 'a casket of glittering gems.'"



20TH CENTURY IDEAS

Tailor-Made SUITS

TO ORDER

Very Special!

We carry no Ready-Made Suits for our

Mail Order Department

EVERY SUIT

Is CUT and MADE

to special order by our own skilled workmen, thus insuring a perfection of FIT and FINISH not obtainable elsewhere.

Send for our new

Special Catalogue

Ready about March 20th IT IS FREE

Schlesinger & Mayer

State, Madison

and Wabash

CHICAGO

This beautiful double-breasted Eton Suit made to order. Price . . . \$12.00 . . . . .

SAMPLES of the Material mailed on application.

**Vapo-Cresolene**

**CURES WHILE YOU SLEEP**

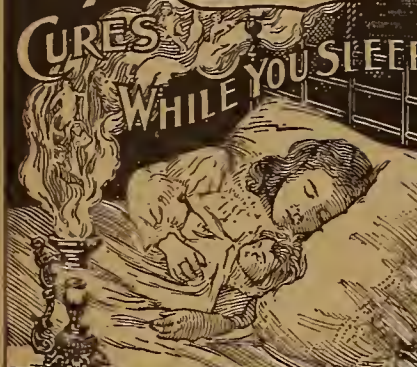

Hundreds of thousands, all over the world, use Vapo-Cresolene. Do you? Cresolene is a specific for Whooping Cough, Croup, Asthma, Catarrh, Coughs, Cold.

A germicide of great value in the treatment of contagious diseases, as Diphtheria and Scarlet Fever.

Descriptive booklet giving testimonials by physicians and prominent people free. Sold by all druggists.

Vapo-Cresolene Co., 180 Fulton St., N. Y. City.

**TERRIFF'S PERFECT WASHER**

SENT ON TRIAL at wholesale price. If not satisfactory money will be refunded. **SOLD** under a FORTNIGHT GUARANTEE to wash as clean as can be done on the washboard, even to the wrist and neckbands of the most soiled shirt, and with far greater ease. Does not wear out the clothes. Economizes soap, labor and time. **AGENTS WANTED.** Exclusive territory given. Big money made. For terms and prices Address, Portland Mfg. Co. Box 27, Portland, Mich.



**WIDE AWAKE WOMEN**

everywhere are furnishing their homes without money by distributing a few of our fine soaps, perfumes, extracts and toilet preparations, among their friends and neighbors.

**No Money Needed**

We send the goods and premiums on 30 days trial and guarantee them. This handsome white enameled iron bed with brass trimmings is only one of our many premiums. You can furnish your home without one cent.

**FREE.** Write for our handsome hook of premiums. Watches, Cameras and Bicycles for boys and girls. Write us at once. Crofts & Reed, 842-850 Austin Av. Dep. G, Chicago, Ill.



**BICYCLES FOR EVERYBODY. NO MONEY IN ADVANCE.**

Shipped direct to anyone and guaranteed as represented or money refunded. Save agents large profits and get a wheel at rock bottom wholesale price. Our Arlington Model K is the greatest bargain ever offered, in lots of one or more at \$14.85

\$35 "Arlington" \$16.50  
\$40 " " \$18.50  
\$50 "Oakwood" \$21.50

Good wheels \$12.50, \$11.00 & \$10.00 Stripped Wheels \$7.00 and the best that can be made. Thoroughly tested and fully guaranteed. Over 100,000 riders can testify to their superior quality, style, construction and workmanship. Illustrated catalog free. **CASH BUYERS' UNION, 162 W. Van Buren St., B-7, Chicago, Ills.**



**WANTED** Reliable men or women to sell our goods to the consumer in communities from 1,000 to 10,000 population; permanent employment at good pay. Address THE GREAT EASTERN COFFEE & TEA CO., 301 South 10th Street, St. Louis, Mo.

**LADIES TO DO PLAIN SEWING** at home, \$1.50 per day, four months' work guaranteed. Send stamped addressed envelope for full particulars. B. W. HUTTON & CO., Dept. 3, Philadelphia, Pa.

"WHEN THE BIRDS GO NORTH AGAIN"

Oh, every year hath its winter,  
And every year hath its rain—  
But a day is always coming  
When the birds go North again;

When new leaves swell in the forest,  
And grass springs green on the plau,  
And the alder's veins turn crimson—  
And the birds go North again.

Oh, every heart hath its sorrow,  
And every heart hath its pain—  
But a day is always coming  
When the birds go North again.

'Tis the sweetest thing to remember  
If courage be on the wave,  
When the cold dark days are over—  
Why, the birds go North again.  
—Ella Higginson.

QUEER TOWNS

**A** FEW miles from Ningpang-po, a town in northern China, there is a large village composed exclusively of graves. The place is, as a matter of fact, a deserted burial-ground, and has been taken possession of by a numerous colony of beggars, thieves and outcasts of all descriptions, who eat, sleep and make merry in spite of their eerie environment, which—such is the influence of familiarity—never seems to enter their otherwise superstitious minds. There are several of these "towns among the tombs" in various parts of the Celestial Empire, but the one we have mentioned is the most extensive. Adjoining a certain famous quarry in Italy is a town whose inhabitants pay neither rent, rates nor taxes. In this blissful retreat the citizens, who are all employed in the quarries, dig out dwellings for themselves in the face of a precipitous rock, roads up the cliff leading to the various ranges of galleries. This community of cliff-dwellers, we fancy, would offer scant encouragement to the speculative jerry-builder.

The marine village of Tupuselei, in New Guinea would take a lot of heating on the score of singularity. Here the houses are all supported on piles, and stand right out in the ocean, some considerable distance from the shore. The object of this strange position is to protect the inhabitants against sudden attacks of the dreaded head-hunters, who are always on the lookout for victims. Other villages in this happy land are perched up in all but inaccessible trees, for the same weighty reason. Another curious place is a town without a name on one of the arms of Lake Huron. This consists of some five hundred wooden huts. During the summer these little dwellings are hidden away in a clearing on shore, and the town contains not a single inhabitant. But on the arrival of winter, when the lake is frozen over with a thick coating of ice, the owners of the huts arrive and proceed to move their houses out to the surface of the lake. The floor of the huts is taken up and a hole cut through the ice. Through these holes the residents fish, carrying on their operations until the spring releases the lake from its icy bonds, when this extraordinary town is once more broken up, the shanties go back to their resting-place, and the fishermen scatter over the country. This place even boasts a curing-factory and a church, not to mention several saloons—all on the ice. Athos, a town situated on a promontory on the coast of Macedonia, well deserves the title of the most curious town in the universe. The peninsula is known as "The Mountain of the Monks," from the fact that a score or so of the monasteries are dotted about the rough hillsides or the valleys. In these establishments dwell a numerous body of ascetics, kind and hospitable to wanderers, but full of superstition, and believing in the doctrine of separation to a wonderful degree. The actual town, as distinct from its monastic environs, is called Caryes, and supplies the simple wants of the monks. Here are to be found streets of shops, crowded bazaars, flourishing trades, and all the bustle and energy of a modern town. But one thing soon strikes the visitor as strange. There is not a female to be seen anywhere, for the gentler sex is rigorously banished from the place. Even the small Turkish garrison, from the commandant down to the privates, consists of hachelors. This extraordinary law is carried out even among the domestic animals. Only the wild birds evade it, and then only when free, for no female bird is even brought to table; the fowl one has for dinner is sure to be a cockerel. For this unparalleled state of affairs there is only a legend to account. Although to our practical minds flimsy to a degree, it is implicitly believed in by the inhabitants. It appears that in one of the chief monasteries on the promontory there is a miraculous icon, which is a picture, or image, sacred to members of the Russian-Greek church. This particular picture is a representation of the Virgin, and the legend says that one day as the Empress Pulcheria, who had liberally endowed the church, as well as beautified and restored it, was engaged in her devotions the Virgin spoke, asking what she, a woman, was doing in the church. The pious lady, no doubt amazed, did not reply, whereupon the voice commanded her to leave, saying that the feet of a woman should never again tread the floor. The empress, probably surprised at the seeming ingratitude of the speech, as well as awe-struck, left the place, which no female has since entered. How the prohibition, thus arbitrarily established, came to comprehend the length and breadth of the promontory is not very clear. As a residence for bashful bachelors we should imagine Athos would be hard to surpass.—Household Words.

**THE ESTEY ORGAN WEARS LIKE TIME**

When father came home from the war in '65, having saved some money, he was enabled to buy for us what our hearts most desired—an organ. It was a little, old-fashioned, severely plain ESTEY ORGAN. That was 35 years ago. The same little organ is in my home today. Of course it sits out in the "back study," but that's where we always go when we gather the family about us to sing the dear old songs, or to spend an evening with "Gospel Hymns." When father visits us we close up the piano entirely and use only the little old organ. There were seven of us at home and this same organ had to stand all kinds of practice, to say nothing of being made to do duty in the little church close by on many occasions. There are six in my own family and each has had a turn at the little organ. So far as I am able to see it is as good as it ever was—strong, clear and sweet in tone, perfect in action and all of the five stops are active and effective. So far as I can remember it has never been cleaned or repaired by an expert and has had only such attention as I have given it myself, about once each five years. I don't think money could buy it. Its future is already arranged for. It will pass on to the third generation. I might go on and tell how this little old organ had been moved about the country from place to place, sometimes in an ordinary farm wagon, by rail, etc., but I forbear. E. E. CRITCHFIELD, Wheaton, Ill., March 2, 1900.

We made the organ mentioned by Mr. Critchfield and we make a better organ today than we did 35 years ago. Send for our large handsome free catalogue. ESTEY ORGAN CO., Madison St., Brattleboro, Vt.

**PROFIT FOR MAKER ONLY**

We manufacture 178 styles of vehicles and 65 styles of harness and sell them to you direct from our factory at wholesale prices. In fact, we are the largest manufacturers of vehicles and harness in the world selling to the consumer exclusively. When you buy on this plan you pay only the profit of the manufacturer. No traveling expenses, no losses, no agent's commission and no dealer's profits.

**WE HAVE NO AGENTS** preferring to deal with you direct. We have followed this plan for 27 years. No matter where you live, we can reach you and save you money. We ship our vehicles and harness anywhere for examination and guarantee safe arrival. We manufacture everything we sell, and we can assure you of good quality from beginning to end; good wood work, good iron and steel, good paint and varnish, good finish, good trimmings, fine style and the largest selection in the land. Large illustrated catalogue FREE.

**ELKHART CARRIAGE & HARNESS MANUFACTURING CO., Elkhart, Ind.**



**Watch and Chain FOR ONE DAY'S WORK.**

This Cut is 1-2 Actual Size of Watch and Chain.

We send this Nickel-Plated Watch, also a Chain and Charm to Boys and Girls for selling 1 1/2 dozen packages of BLUINE at 10c. each. Send your full address by return mail and we will forward the Blaine, postpaid, and a large Premium List.

No money required. We send the Blaine at our own risk. You go among your neighbors and sell it. Send us the money that you get for it and we send you the Watch, Chain and Charm, prepaid.

This is an American Watch, Nickel-Plated Case, Open Face, Heavy Beveled Crystal. It is Guaranteed to keep Accurate Time, and with Proper Care should last ten years.

**BLUINE CO., Box 392 CONCORD JUNCTION, MASS.**  
The Old Reliable firm who sell honest goods and give Valuable Premiums.



**FREE! SEND NO MONEY TO LADIES, BOYS AND GIRLS**

We send this elegant solid gold or sterling silver-plated Bracelet, beautifully engraved, with a dainty little lock and key, also 3 extra gold or silver Friendship Hearts, for selling only 5 sets of our latest style 14-karat gold filled Ladies' Dress or Beauty Pins at 25c. a set. Each Pin is set with an exquisite large jewel; or will send this solid gold shell latest style set ring for selling 5 sets. Our rings are set with an exquisite Ruby or Emerald stone, and they are hard to tell from a \$5.00 ring. Send us your name and address only, no money, and we mail you the Pins post-paid. After you sell them among your friends and neighbors, send us the money, and we will send you your choice of the above presents, or many others which you will find in our Large Premium Catalogue of Watches, Jewelry, Tea and Dinner Sets, etc., free with each lot of Pins. You will find these Pins the fastest seller you ever handled. Every stylish lady and girl in the land will buy several sets at sight. We sell over a million each month. This premium is offered by a strictly reliable house. We take back all you cannot sell, and pay postage on goods and premiums. Don't fail to take advantage of the grandest offer ever made! Write to-day; don't put it off! This firm is well known for its honest goods and valuable premiums. **ST. LOUIS PREMIUM CO., Dept. A 28, St. Louis, Mo.**

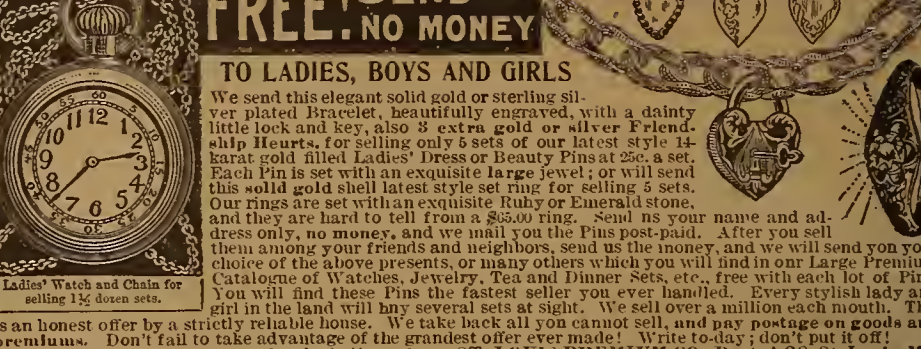

**Artistic Monuments**

**COST NO MORE THAN PLAIN ONES in White Bronze**

Marble is entirely out of date. Granite soon gets moss-grown, discolored, requires constant expense and care, and eventually crumbles back to Mother Earth. Besides, it is very expensive. **White Bronze** is strictly everlasting. It cannot crumble with the action of frost. Moss growth is an impossibility. It is more artistic than any stone. Then why not investigate it? It has been adopted for nearly one hundred public monuments. We have designs from \$4.00 to \$4,000.00. Write at once for free designs and information. It puts you under no obligations. We deal direct and deliver everywhere.

**The Monumental Bronze Co., 347 HOWARD AVENUE, BRIDGEPORT, CONN.**



**CUT THIS OUT THE ILLUSTRATED BEE TEN WEEKS TRIAL SUBSCRIPTION 15c**

A Western Illustrated Weekly News Magazine. Interesting pictures of every-day happenings, prominent men and women of the day. Illustrated stories and magazine articles, fashion plates from live models. Oriental pictures from Frank Carpenter's camera, etc., etc.

Cut this out and enclose 15 cents to THE ILLUSTRATED BEE, 1706 Farnam Street, Omaha, Neb.

**TRIAL SUBSCRIPTION COUPON**

**HOT SPRINGS, ARK. VIA IRON MOUNTAIN ROUTE**

The World's Sanitarium and All-Year-Round Pleasure Resort, reached only via this line. Elegant Hotels; Sublime Scenery; Delightful Climate; Healing Hot Springs. Pullman Buffet Sleeping Cars, without change, from St. Louis. Reduced Round Trip Rates all year round, from all coupon points in the U. S. and Canada.

For descriptive and illustrated pamphlet, write Company's agents, or H. C. TOWNSEND, General Passenger and Ticket Agent, ST. LOUIS, MO.



**TWO COSTLY PRESENTS; YOU GET BOTH.**

WE TRUST AGENTS with 12 new style, Stone Set, Enamel Scarf and Stick Pins, different patterns. Everybody wears them. Sell to your friends for 10 cents each, and we give you Free a Fine Gold or Silver Imitation Bracelet (with lock and key), also this magnificent Solid Gold Imitation Band Ring, handsomely engraved, a perfect beauty, wears a lifetime. Send names; no money required until pins are sold; we take all not sold. Address PEARL PIN CO., Providence, R. I.







AN EASTER SONG

I wonder if the anguished moon looked down  
Through all that last long night  
And buried in her scarred breast, lean and brown,  
The memory of that sight!  
I wonder if th' uneasy birds awoko  
As glowed that strange, great light  
Which paled the purpled east where morning  
broke,  
And sang, inspired by God's own breath,  
"There is no death! There is no death!"

There is no death, O hearts that throb in vain  
With longing, pulsing tide,  
Or in love's fullness, nigh akin to pain,  
Unfearingly abide;  
There is no death, O soul whom niggard fate  
Has left unsatisfied,  
The cycles swing and joys those lips await  
Who oft have sung on earth in pain,  
"I rise again! I rise again!"

No sacrifice, O self, can blot thee out  
Or satisfy the debt  
Which binds thee to the usurer of doubt  
With interest of regret!

Still is not life to even thee denied;  
One way remaineth yet—  
As was thy Christ must thou be crucified.  
But with those wounds in hands and feet  
E'en self finds resurrection sweet!

Rejoice, O soul whose work is just begun,  
That all time lies before!  
Rejoice, O heart whose treasures all have won  
That dimmer farther shore!  
The stone that angels moved away that night  
Was rolled from heaven's door;  
Awake and stand forth in hope's sudden light,  
And sing as sang the birds that morn,  
"There is no death, for life is born!"

HOPE

BY REV. C. A. KOENIG

THE poet Hesiod tells us that the miseries of all mankind were included in a great box, and that Pandora's husband took off the lid, by which means all of them came abroad, but Hope remained still at the bottom.

Thus hope is the principal antidote which keeps our hearts from bursting under the pressure of evils, and is that flattering mirror which gives us the prospect of some great good. When all other things fail hope stands by us to the last. This, as it were, gives freedom to the captive, health to the sick and victory to the defeated. The hope of men who live "without God" is like moonlight borrowed from the sun to mitigate the darkness which it cannot dispel. It is adapted to a transitory, imperfect state, and it diminishes in some measure the sorrows of the present by drawing beforehand on the stores of the future joy. Such worldly hope is nothing more than a state of mind partaking of so much doubt, as leaves them very little above the level of despondency.

But Christian hope is not a mere feeble expectation or desire without expectation. It is a sure and steadfast anchor. It is the desire and expectation of those future good things which God has promised in his word. Applied to these rich gifts of God and the highest interests of man hope reaches from earth to heaven, and fastens the anchor of the soul within the veils, so that the expectation of eternal rest may enable the weary to bear with patience the tossings of Time's troubled sea. This Christian hope is a pure and bright star fixed high in heaven. It reaches with its rays the uplifted eye of the weary pilgrim until the ransomed opens his eyes in the presence of the sun of righteousness, where hope no longer is needed.

THE BLESSING'S SHADOW

BY C. H. SPURGEON

Prayer is always the preface to blessing. It goes before the blessing as the blessing's shadow. When the sunlight of God's mercies rises upon our necessities it casts the shadow of prayer far down upon the plain. Or, to use another illustration, when God piles up a hill of mercies he himself shines behind them, and he casts on our spirits the shadow of prayer, so that we may rest certain, if we are much in prayer, our pleadings are the shadows of mercy. Prayer is thus connected with the blessing to show us the value of it. If we had the blessings without asking for them we should think them common things; but prayer makes our mercies more precious than diamonds. The things we ask for are precious, but we do not realize their preciousness until we have sought for them earnestly.

ENTERTAINING THE MINISTER

A minister, when on exchange at one time, was entertained by a hostess who had conscientious scruples against the preparation of warm food on the Sabbath. After a long ride and an exhausting service he was served, much to his discomfort, to sliced cold potatoes and pork. He was compelled to ask for a piece of bread. Such thoughtlessness seems incredible, yet this is the record of veritable experience.

Another minister had been given before service a breakfast of eggs, which was not his customary diet. After the service one of his congregation who knew the circumstances said, "If that is an egg sermon, I should like to know what a beefsteak sermon would be." This remark, intended both as a compliment and a witticism, contains a hint as to the effect of the morning meal upon a preacher's public ministrations.

This, then, is wholesome advice to all hospitable church-members. First, to church committees: Furnish your candidate if possible with a pleasant room in a good hotel, where his time can be his own and he can be free to prepare himself as he wishes for the services of the day. Secondly, where this is impossible let the families who have the privilege of entertaining the minister give him a warm room where he can spend as much time as he chooses. Let him understand that he is not expected to entertain the entire household. See to it that he is furnished with nutritious and well-prepared food. Thirdly, don't leave him, even if in the vicinity of Boston, to the sole option of baked beans and brown bread.

Equipose and enthusiasm are impossible with a stomach ill at ease or with nerves exhausted by sleeplessness. In every church community let there be at least one family who shall understand and cultivate the art of entertaining the minister.—The Advance.

THE SENTINEL OF THE SOUL

If conversion exterminated every evil lust and every sinful appetite and every susceptibility to wrong-doing, then serving Christ would be as easy as breathing. But if Paul had to do battle with the "old Adam," so must you and I. Conscience is the sentinel of the soul. It is that faculty which detects the difference between right and wrong, which decides on the right or wrong course of action, and which approves or condemns the course we take. A vitally important thing is an acute conscience; it is the divine voice speaking within us, when it is enlightened and instructed by the word of God. Never tamper with it any sooner than the helmsman on a ship would tamper with the needle in his compass. The approval of conscience is one of the sweetest of comforts; the condemnation of conscience is one of the most bitter of sufferings. When a professed Christian gets used to sinning, and feels but little compunction about it, he is far gone in backsliding. The way to keep from backsliding is to avoid the first false step; when you once start on that toboggan-slide you will soon find yourself at the bottom.

Let me emphasize the grace of watchfulness. If Satan always came as a hideous fiend we should take the alarm; it is when he rigs himself out as "an angel of light" that he becomes dangerous. The temptations that jump with our own natural inclinations are the dangerous ones; keep a double watch there. Our hearts, after all, are very much like tinder-boxes; and there are plenty of sparks flying. If you have not the grace to keep them out, or to extinguish them as soon as they light, then comes the explosion! There is one alarm-bell that our blessed Master rings very often; it is, "I say unto you all, watch!"—Christian Endeavor World.

HELPFUL THOUGHTS

Abundance without discretion is plain penury.—Garibaldi.

Nothing is more terrible than to see ignorance in action.—Goethe.

The real character of man is found out by his amusements.—Sir Joshua Reynolds.

Our grand business is not to see what lies dimly at a distance, but to do what lies clearly at hand.—Carlyle.

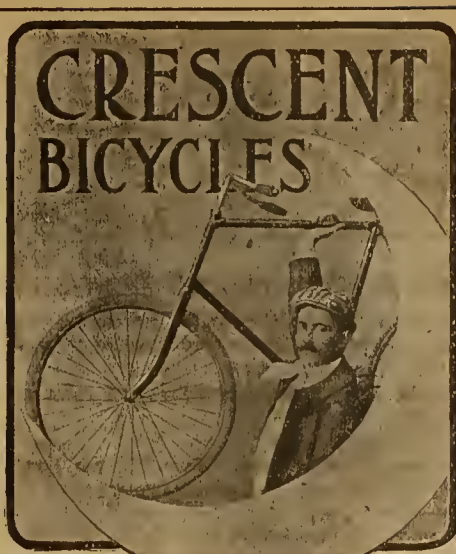

The perfection in bicycle construction is demonstrated in the smooth-running qualities of the Crescent Bevel-Gear Chainless.

Bevel-Gear Chainless Models, \$60  
Chain Models, \$25, \$26, \$30, \$35

SEND FOR CRESCENT CATALOGUE

The Crescent Bicycle

601 Wells Street, CHICAGO 30 Warren Street, NEW YORK

STERLING BEVEL GEAR CHAINLESS BICYCLE

The difference between a \$100 Elgin and a \$1.00 Waterbury is more than in the position of the decimal—it's in the quality. It is just so with wheels. The Sterling Bevel-Gear Chainless is the Elgin of wheels—it has the quality. That's the whole story in a sentence.

PRICE \$75

Chain Models, \$40.00, \$50.00

SEND FOR CATALOGUE

THE STERLING BICYCLE

501 Wells Street, Chicago, Ill. 36 Warren Street, New York

BEST FOR THE BOWELS

If you haven't a regular, healthy movement of the bowels every day, you're sick, or will be. Keep your bowels open, and be well. Force, in the shape of violent physic or pill poison, is dangerous. The gentlest, easiest, most perfect way of keeping the bowels clear and clean is to take



Pleasant, Palatable, Potent, Taste Good, Do Good, Never Sicken, Weaken, or Gripes, 10c, 50c Write for free sample, and booklet on health. Address Sterling Remedy Company, Chicago, Montreal, New York, 322a

KEEP YOUR BLOOD CLEAN

\$27.15

Buys the Best Steel Range on EARTH. Handsomely decorated in nickel. A FINE BAKER. Guaranteed to bake biscuits in five minutes. Write for circulars.

Columbia Steel Range Co. 550 North Street, KOKOMO, INDIANA.

\$1,000 SALARY PER YEAR!

Ladies or Gentlemen We have shared the general prosperity of the country, and we now need one or two permanent representatives in each state to look after our interests, manage our agents, and attend to collections. This position involves no canvassing and is a bona fide weekly salaried position, with all expenses paid, to the right party. It is mainly office work conducted at your own home, with an occasional trip out among the agents. No investment required. Also three salaried vacancies in the traveling department. Enclose references and self-addressed stamped envelope to PROVIDENCE CO., 2 Carlton Bldg., CHICAGO.

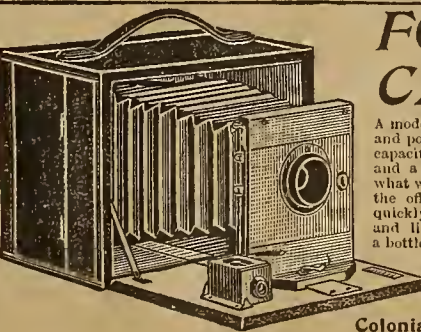

FOLDING CAMERA FREE

A model of the workmen's art, wood parts Mahogany finish, brass work lacquered and polished, covered with Morocco leather, fitted with high-grade Achromatic lens, capacity eight 4x5 inch plates, same as shown. You can get this first-class camera and a handsome Bracelet with lock and key for selling our Granules. We mean what we say and will give this reliable Camera absolutely free if you comply with the offer we send to every person taking advantage of this advertisement. To quickly introduce our Health Granules, a positive cure for constipation, indigestion and liver troubles, if you agree to sell only SIX bottles of Granules at 25 cents a bottle, write at once and we promptly send Granules by mail. When sold send us the \$1.50 and we send you a handsome Bracelet together with our offer of a folding Camera same day we receive the money. This is a genuine offer by a reliable concern, and all who receive the Bracelet and Camera for selling our Granules are delighted.

Colonial Trading Co., Dept. B2, 404 Atlantic Ave., Boston, Mass.

**Cleveland**  
BEVEL-GEAR  
**Chainless**  
BICYCLE

THE Cleveland Bevel-Gear Chainless Bicycles have a standard of value that satisfies the most critical.

PRICES  
Chainless Model, . \$75  
Chain Models, \$40, \$50

SEND FOR CATALOGUE  
MAIN OFFICE:  
CLEVELAND, OHIO

**CLIPPER**  
BICYCLES

SAVE YOUR STRENGTH

You can cover the same ground with less energy by using the

**Clipper Bevel-Gear Chainless**

The secret is in the Bevel-Gear. Price \$60 and \$75

CHAIN WHEELS \$50 and \$40

For Catalogue address the Rambler office, North Franklin Street and Institute Place, Chicago, Illinois

AN ACRE OF CORN

and its possibilities under the Silage system—being the theme of

"A BOOK ON SILAGE"

By Prof. F. W. WOLL,

of the University of Wisconsin, neatly bound into a volume of 195 pages and now being sent out by the SILVER MFG. CO., SALEM, O., is unquestionably the best book yet introduced on the subject. It includes:

I—Silage Crops. II—Silos.  
III—Silage. IV—Feeding of Silage.  
V—Comparison of Silage and other Feeds.  
VI—The Silo in Modern Agriculture,  
and many valuable tables and compounded rations for feeding stock. They are going rapidly.

To avoid disinterested inquiries the Price is 10c. coin or stamps.

SILVER MFG. CO.  
Salem, Ohio.

WALL PAPER

See our samples before placing your order. Agents wanted everywhere.

KAYSER & ALLMAN,  
1214-16 Market Street, Philadelphia, Pa.

Brass Band

Instruments, Drums, Uniforms, & Supplies. Write for catalog, 445 illustrations. FREE; it gives information for musicians and new bands.

LYON & HEALY,  
95 Adams St., CHICAGO.

Ladies' Combination Jewelry Set

Consisting of Brooch, Two Collar-Buttons, Two Cuff-Buttons, and Three Beauty Pins. Send 50 cents for one of the Outfitters.

DEPT. A, LOCK BOX 652, WHEATON, ILL.

LEARN TELEGRAPHY

For Railroad and Commercial Service. Typewriting Course FREE. Paying positions guaranteed. Catalogue Free.

FISK TELEGRAPH SCHOOL, LEBANON, PA.





"SISTER'S BEST FELLER"

My sister's "best feller" is 'most six-foot-three, And handsome and strong as a feller can be; And sis, she's so little and slender and small, You never would think she could boss him at all; But, my jing! She don't do a thing But make him jump round like he worked with a string; It just makes me 'shamed of him sometimes, you know, To think that he'll let a girl bully him so.

He goes to walk with her and carries her muff And coats and umbrellas, and that kind of stuff; She loads him with things that must weigh 'most a ton; And, honest, he likes it, as if it was fun. And, oh, say! When they go to a play He'll sit in the parlor and fidget away, And she won't come down till it's quarter past eight, And then she'll scold him 'cause they get there so late.

He spends heaps of money a-buyin' her things Like candy and flowers and presents and rings; But all he's got for 'em's a handkerchief-case— A fussed-up concern made of ribbons and lace— But, my land! He thinks it's just grand, 'Cause she made it, he says, "with her own little hand."

He calls her an "angel"—I heard him—and "saint," And "heautifullest hein' on earth"—hut she ain't. 'Fore I go on an errand for her any time I just make her coax me and give me a dime; But that great, big silly—why, honest and true!— He'd run forty miles if she wanted him to. Oh, gee-whiz! I tell you what 'tis! I just thiuk it's awful—those actions of his. I won't fall in love when I'm grown—no, sir-ee! My sister's "best feller" 's a warnin' to me!

—Joe Lincoln, in Puck.

ADVICE GRATIS

There are two kinds of things, my son, that you should never worry about—those things which cannot be avoided and those which can be. That which cannot be helped may as well be accepted with resignation, and instead of fretting yourself about that which can be avoided, better save time and nerve-tissue by taking the necessary means to avoid it.

There are two other classes of things about which it is also foolish to worry—the things of the past and the things of the future. The former are beyond mending, and therefore, like spilt milk, not to be changed by lamentations; and as to the latter, they may never happen, and so your worryment will be all for nothing.

Do not spend your time in seeking what you do not wish to find, and the finding of which would only serve to make you miserable.

If you would succeed as a writer seek first to establish a reputation for turning out good literature. Your reputation once gained you can deluge the reading public with the poorest kind of rot, and the reading public will devour it eagerly and declare that such appetizing and nutritious mental food never was before presented to it.

In conversation do not attempt to utter brighter or weightier things than others. This is something which never will be forgiven you. Use your ears rather than your tongue if you would be esteemed. If, however, you must speak wise or witty words, do it in such a manner as will flatter your interlocutor to think that you merely give utterance to the thoughts that were imparted by his sayings.

If any one gets out of temper with you take care to preserve your own equanimity. Better that there should be two fools than one, provided the one is not yourself.

Do not make yourself the burden of your conversation. It may be the only subject with which you are at home, but it is not likely for that reason to prove the more interesting to others, who prefer to talk about their own selves.

Because you are young, and are finding out new things every day, do not forget that it is possible that those things were known to your elders long before you were weaned.—Boston Transcript.

DREADFUL THOUGHT

One day four-year-old Harry saw four funerals pass by the house, and in a little while he began to cry.

"Oh, why don't I die!" he wailed. "Heaven will soon be full, and there won't be any room for me."

LE ENFANT TERRIBLE

Caller (to child, whose mother has left the room for a moment)—"Come here to me, my dear."

Enfant terrible—"No, I mustn't do that. Mama told me I must stay sitting in the chair, because there's a hole in the cushion."

HOW ROBBIE SPOILT THE ANSWER

At a school examination in the North of Scotland the following questions were asked by the inspector:

Inspector—"Now, boys, how many of you are there in this class?"

Boys—"Ten, sir."

Inspector—"Quite right. Now tell me how many hands and feet are there amongst you?"

Boys—"Forty, sir."

Inspector—"Quite right."

After a momentary pause one of the boys held up his hand.

Inspector—"What is it, my hoy?"

Boy—"Please, sir, there's only thirty-nine, as Robbie Thomson has only got one foot."—Spare Moments.

SEASONABLE

A strong-minded woman, albeit she looked it not, moved into a rather lonely suburb, and the house was topsy-turvy from the moving. On the second night the strong-minded woman was awakened by the light of a dark-lantern shining into her face from the hand of a burglar. It was the last straw, and she sat up in bed and exclaimed, with vexation, "Well, if you can find anything in this house you're welcome to it; it's more than I can do!"

The burglar snapped down the slide of his lantern. "Good-night," he said, and left the house without touching a thing.

A COMPANION PIECE

"I suppose," said the thoughtful one, "that 'Maud Muller' might be called the companion poem to 'The Man With the Hoe.'"

Quote the thoughtless one, "I can't imagine why."

"Well, Maud was the girl with the rake, you remember."—Judge.

HE KNEW THAT ONE

A little fellow who has not as yet succeeded in learning the name of the three daily meals came down to breakfast the other morning, when his mama said, "Well, Rollo, what meal is this?"

"Oatmeal," was the confident reply.

NEGATIVE COMFORT

"Dear Lord," returned Dorothy at her morning devotions, "I thank you that you didn't make me a centipede, 'cause then 'twould be awfully hard to button up so many shoes before breakfast."—Judge.

THE PRODIGAL SON'S RETURN



1.—Prodigal son—"Dear old home, I'll return. Father will kill the fatted calf, I'm sure."

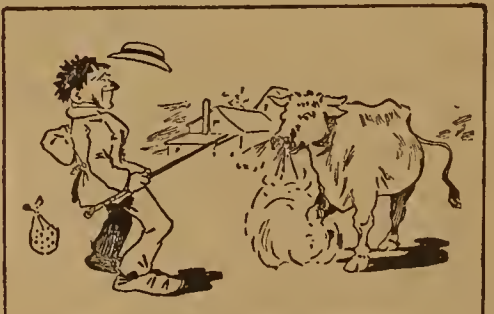

2.—But during his absence the fatted calf had grown considerably—



3.—And the prodigal was given a lively reception.—Boston Herald.

You worry over trifles, and strange fancies, born of a disordered mind, rob you of sleep. Things which would not trouble you in the day take horrible shape at night and bring dreams which rob your sleep of benefit. Or you toss uneasily, asking for morning to come. Sights and sounds annoy you and stillness oppresses you. You complain of numbness and a prickling sensation in the limbs. You are "an absent-minded beggar."

That's Nervous Prostration

"During last year I was suffering with nervous prostration. For weeks I grew worse, became thin, could not sleep, had no appetite, and was in a wretched condition. After taking several kinds of medicines without result, I took Ayer's Sarsaparilla with more than pleasing results. My appetite returned, I slept soundly, my strength and weight increased, and now I am well and strong without the slightest trace of my old trouble. Indeed, I would hardly believe it possible for medicine to bring about such a change in any person."—CLARA MEALY, Winter Hill, Somerville, Mass., Dec. 21, 1899.

A delicious and highly scientific blend of the strongest and purest vegetable extracts.

That's AYER'S

Manufactured under the personal supervision of a graduate in pharmacy, a graduate in chemistry, and a graduate in medicine.

You are as tired in the morning as you are at night, and yet your tired doesn't bring sweet, sound sleep. You have an appetite, yet food seems to nauseate you. Your mind does not respond quickly and your memory fails you. You lack energy, the eyes droop, the head is tired and heavy. You want to do many things, yet do no one thing satisfactorily. Most likely,

That's Overwork

"Last July my oldest daughter was taken sick, and I was on my feet, it seemed to me, night and day for weeks taking care of her. I had no other help than that which my husband gave me, and by the time daughter began to mend I was down sick myself. I was discouraged, and did not care much whether I lived or died. My husband got me a bottle of Ayer's Sarsaparilla, and its effects were magical. Two bottles of this medicine put me on my feet and made a well woman of me."—JANE M. BROWN, Bentonport, Iowa, Jan. 19, 1900.

FREE SILVER WATCH FREE! These Watches are Solid Silver, Ladies' or Gents' size, and at retail would cost upwards of \$8. or \$10, but to introduce our Persian Perfumed Perfumery we will send you this Watch Free if you take advantage of our marvelous offer. If you want one CUT THIS OUT write to us without delay. With your letter send us your name & postoffice address and we will send you on consignment, to sell for 5 cents each, 20 cases of Persian Perfumed Perfumery and our offer. After you receive the beautiful Watch we shall expect you to show it to your friends and call their attention to this advertisement. The Watch is sent Free, by Registered Post, on your complying with our advertisement, and the marvelous offer which we send, and it is Fully Warranted. You will be more than satisfied. Address at once, PERSIAN PERFUMERY CO., 19 Warren St., New York.

WANTED MAN with horse and buggy, to sell Pasture Stock Food. Salary \$15.00 per week and 10 per cent on all sales. Farmer preferred. Previous experience not essential. PASTURE STOCK FOOD is the greatest discovery ever made in practical and scientific feeding, and is sold on an absolute guarantee. Steady, permanent trade easily established. Sample bag, sufficient for two weeks' feeding, free. Send 25 cents in stamps or silver to cover express charges. PASTURE STOCK FOOD COMPANY, 301 Boyce Building, Chicago.

DON'T BE HARD UP \$2,000 A YEAR EASY Gold, Silver, Nickel & Metal Plating. Gents and Ladies at home or traveling, taking orders, using and selling Prof. Gray's Plating. Plates, Watches, Jewelry, Tableware, Bicycles, and all metal goods. No experience, heavy plate, modern methods. We do plating, manufacture outfits, all sizes. Guaranteed. Only outfits complete, all tools, lathes, materials, etc., ready for work. We teach you the art, furnish secrets and formulas FREE. Write today. Testimonials, samples, etc. FREE. C. GRAY & CO., PLATING WORKS, 8, Cincinnati, O.

\$3 a Day Sure Send us your address and we will show you how to make \$3 a day absolutely sure; we furnish the work and teach you free; you work in the locality where you live. Send us your address and we will explain the business fully; remember we guarantee a clear profit of \$3 for every day's work, absolutely sure, write at once. ROYAL MANUFACTURING CO., Box 64, DETROIT, MICH.

\$83.33 MONTHLY SALARY PAYABLE WEEKLY with EXPENSES Men or Women to represent us in their own state. Your duties to take charge of solicitors and attend to collections. No investment required. Send stamp for application blank. CO-OPERATIVE CO., 305 Star Bldg., Chicago, Ill.

1427 Silk Fringe Cards, Love, Transparent, Escort & Acquaintance Cards, New Fancies, New Games, Premium Articles, etc. Finest Sample Book of Visiting & Hidden Name Cards, Biggest Catalogue. Send 2c stamp for all. OHIO CARD CO., CANTON, OHIO.

GOLDMETER in pocket case for hunting Minerals, Gold and Silver, also Rods and Needles. Circular 2 cents. B. G. STAUFFER, Dept. F. F., Harrisburg, Pa.

PLAYS Dialogues, Speakers, Amusement Books. Catalog free. T. S. DENISON, Publisher, Dept. 5, CHICAGO.

We Pay \$18 A WEEK AND EXPENSES to men with rigs to introduce our Poultry Compound. Send stamp. Javelle Mfg. Co., Dept. 53, Parsons, Kan.

Inflicted with SORE EYES DE ISAAC THOMPSON'S EYE WATER

PILES CURED AT HOME By the Use of "MERTANNO" A specific for the immediate relief and permanent cure of Blind, Bleeding, Itching and Protruding Piles. Price, postpaid 50 cents. Our Guarantee: We will refund the price paid for this remedy in any case of Piles it does not cure. Send for testimonials, free. Mertanno Pharmacal Co., 403 Scott St., Covington, Ky.

FAT How to Reduce it Mrs. L. Lanier, Marlin, Tenn., writes: "I reduced my weight 2 1/2 lbs. in 15 days without any unpleasant effects whatever." Purely vegetable, and harmless as water. Any one can make it at home at little expense. No starving. No sickness. We will mail a box of it and full particulars in a plain sealed package for 4 cents for postage, etc. HALL CHEMICAL CO., Dept. B, St. Louis, Mo.

THE ELECTRICITY from the batteries will turn a needle through your table or hand. Cures Rheumatism, Liver and Kidney disease, weak and lame back, etc. For advertising purposes we will give ONE BATTERY FREE to one person in each locality. Address E. J. SWEAB & CO., Dept. No. 369, Vineland, N. J.

RUPTURE Sure Cure at home; at a small cost. No operation, pain, danger or detention from work. No return of Rupture or further use for Trusses. A complete, radical cure to all (old or young). Easy to use; thousands cured; book free (sealed). DR. W. S. RICE, Box F, Adams, N. Y.

ECZEMA Facial Blemishes, Tetter, Salt Rheum, Barber's Itch, Scald Head, Ring Worm, Itching Piles, Sore Eyelids, and all Skin diseases promptly cured by Spencer's Ointment. Sent to any address on receipt of 25c. A. O. PILSON, Pharmacist, 1327 W. Baltimore St., Baltimore, Md.

Myself cured, I will gladly inform any one addicted to Morphine, Opium, Laudanum or Cocaine OF A NEVER-FAILING, HARMLESS HOME CURE. MRS. M. F. BALDWIN, P. O. Box 1212, Chicago, Ill.

and Liqueur Habit cured in 10 to 20 days. No pay till cured. Write DR. J. L. STEPHENS CO., Dept. A3, Lebanon, Ohio.

WANTED AGENTS in every county to sell "Family Memorials;" good profits and steady work. Address Campbell & Co., 155 Plum St., Elgin, Ill.

Coe's Eczema Cure \$1 at druggists. 25c. box of us. COE CHEM. CO., Cleveland, O.

BED-WETTING CURED. Sample FREE. Dr. F. E. May, Bloomington, Ill.



**MISSOURI PACIFIC RAILWAY** and **IRON MOUNTAIN ROUTE**

**Low Rate Excursions to the West and Southwest...**

TICKETS ON SALE **APRIL 17th**

For Further Information, Folders, Land Pamphlets, Maps, Etc., address any agent of the company, or

**H. C. TOWNSEND**  
General Passenger and Ticket Agent  
St. Louis, Mo.

**SOLID GOLD RINGS FREE!**

Send full name and address and we furnish you 12 fast selling Scarf Pins, Heavy Gold Plate, different styles, set with Precious Gems. Experts can't tell them from the genuine. You sell them at 10c each, return us \$1.20, and we give you FREE either of these **SOLID GOLD RINGS**. We make them. You can't get them elsewhere. We take back pins not sold.

**HENRY MUNDELL DIAMOND PIN CO.**  
155 FRIENDSHIP ST., Providence, R. I.

**\$3.33 HUNTING CASE**

**WALTHAM GOLD FILLED**

Watches are the best. Read our great bargain: Cut this out and send it to us with your address and we will send you C. O. D. for examination before paying one cent. One beautiful 14K gold plated, double hunting case watch, stem wind and set. Ladies or Gents' size, fitted with fine jeweled works, a guaranteed time-keeper, equal in appearance to a \$50.00 gold filled watch warranted for 20 years. If satisfactory pay express agent \$3.33 and charges. Address **W. HILL MFG. CO.** 344 STATE ST., CHICAGO.

**\$25.00 A WEEK**

**BRADFORD'S AUTOMATIC WASHER**

Does complete washing, from fine laces to heavy quilts, in 15 to 30 minutes, without rubbing. Put the clothes in, machine does the rest. Cleaner, easier, better than old-style back-breaking washboards and machines. Positively the best selling, most legitimate article on the market. Mr. Hallinan, of N. Y., sold three dozen first week. Mr. Bobb, of Ind., made \$12 in one day. Miss Stevens, of Tenn., \$138 a month. Everybody wants one when they see it work. Many making \$100 a week. Appointing agents supplying the big demand. **\$50 A WEEK WHY NOT YOU?** Write to-day for how to get an Agent's Sample Free. We start you in business. No scheme, fraud or fake methods. Address **BRADFORD & CO., B 40, CINCINNATI, OHIO.**

**Solid GOLD or SILVER**

plated Bracelet sent for 25c. a set; (each pin jewel.) Simply send we will send you the gold sent as the money Bracelet. The chain and the lock opens with a dainty little key. We trust you & will take back all the pins you cannot sell. Write to-day.

**THE MAXWELL CO., Dept. 555, St. Louis, Mo.**

**\$14 IT COSTS NOTHING**

to try our Sewing Machines. We ship direct from factory to consumer. Save agents' profits. 30 days free trial. 117,500 sold. Warranted 20 Years. All attachments free.

\$40.00 Arlington for.....\$14.00  
\$45.00 Arlington for.....\$16.00  
\$60.00 Kenwood for.....\$21.50  
Other Machines at \$8, \$9 & \$11.50

Illustrated catalogue and testimonials free. Write at once for our special freight offer. Address, **CASH BUYERS' UNION, 158-164 W. VanBuren St., B 7, Chicago, Ill.**

**WE SHIP ON BICYCLE \$100 DEPOSIT**

\$11.75 buys a Bicycle Complete. Unguaranteed. Buys an Up-To-Date Model. Fully guaranteed. Buys a Full Racing Model. Shop-worn Bicycles from \$10 up. 2nd Hand Wheels from \$5.00 up. We want agents everywhere. 64 page catalogue of bicycle parts and repairs free. Write for catalogue and see how you can get a Bicycle free by helping us advertise. Address: Dept. 843, **VICTOR MANFG. CO.** 161-167 Plymouth Pl., Chicago, Ill.

**The New Process**

(PATENT APPLIED FOR)

Will keep foods, raw or cooked, fresh for weeks, without cost. NO ICE, NO CHEMICALS. Complete appliance, capacity two gallons, and full information for \$3.00. Agents can have exclusive territory and staple business. **ORIN PARKER, 94, Rochester, N. Y.**

**10 Weeks** The biggest, brightest and best Western Weekly paper in existence. Grand views of scenery, stories of adventure and full mining reports weekly. Tenth year. Solely to introduce the paper it will be sent 10 weeks on trial for 10c.; clubs of six 50c.; 12 for \$1. Stamps taken. **ILLUSTRATED WEEKLY, DENVER, COLO.**

**Dr. Isaac Thompson's Eye Water**

If afflicted with SORE EYES USE

**HOUSEHOLD**

[CONTINUED FROM PAGE 13]

RICE

THE United States Department of Agriculture has recently published a book, written by Dr. Knapp, on "Rice Culture in the United States." Of the use of rice Dr. Knapp says: "As a food material rice is nutritious and easily digestible. In comparison with other grains it is poor in protein and fat and correspondingly rich in carbohydrates. The relative value of rice and wheat based on the total nutritive material is 87 to 82.54.

There is no doubt there would be much more rice eaten if people more generally knew of the many toothsome and nutritive dishes which may be prepared from it. In the Northern states rice is used chiefly as a dessert, boiled and served with some sweet sauce, or made into a pudding with milk and eggs. In rice-producing countries it takes the place of the Irish potato to a large extent, but the boiled rice of these countries is a very different dish from the solid, pasty article which is frequently served by ignorant cooks.

Rice when properly boiled should be dry and white, each grain thoroughly cooked and soft and yet whole and separate. To attain this result, pick the rice over carefully and wash it in warm water. Have a saucepan of boiling water slightly salted on the stove, into which sprinkle the rice slowly, so that it will not stop boiling. Let the rice boil steadily for twenty minutes, then drain off all the water and set the saucepan on the back of the stove with the cover partly off, where it will keep warm and the moisture will pass off in steam. Shake the saucepan well and empty the rice into a dish. Serve as potatoes to be dressed with gravy from the roast, with plain tomato sauce or curried tomatoes. Rice is also excellent boiled as above and then prepared with cheese as macaroni.

I add some receipts taken from a cook-book published in Charleston, South Carolina, in 1847. The author says: "This book is a selection from family receipt-books of friends and acquaintances, who have kindly placed their manuscripts at my disposal." Among these receipts are more than fifty dishes in which rice forms a part of the ingredients.

**RICE SOUP.**—Put six ounces of rice in a two-quart pot of water, boil for an hour, thicken with the yolks of two, four or six eggs beaten with some cream, a little flour and six ounces of butter. Serve with grated Parmesan cheese.

**RICE MUFFINS.**—To half a pint of boiled rice add a teacupful of milk, three eggs well beaten, one spoonful of butter and enough wheat-flour to make the batter as thick as pound-cake. Bake in a quick oven. The same receipt with less flour makes griddle-cakes.

**RICE SPIDER-BREAD.**—A cupful of cold boiled rice, two cupfuls of flour, three eggs. Beat the rice and flour together, add the eggs, beat the mixture well, and bake in a hot spider.

**RICE FLANNEL-CAKES.**—Half a pint of soft-boiled rice, a teacupful of cream, a teacupful of sugar, three eggs, yeast, and flour to make batter. Let rise, and bake on a griddle.

**CAROLINA RICE-BREAD.**—Boil a pound of rice until it is quite soft; when it is cool mix with it yeast and salt as for other bread, and wheat-flour enough to make a dough that you can knead. Let it rise in a warm place, then make into loaves, let rise again and bake.

**RICE CRUMPETS.**—One and one half pints of rice-flour, one pint of milk, a dessert-spoonful of butter and four spoonfuls of yeast. Stir all together, cover the dish and set it in a warm place to rise. Bake on a griddle. In the above receipts, where yeast is not used tartaric acid and soda are mentioned, as this was in the days before baking-powders were known.

**FRENCH PILAU.**—Cut up and boil a pair of young fowls. When they are tender take them out and put a pound of rice into the same water and let it cook until soft. Then mix into the rice a spoonful of butter, a teacupful of milk and two beaten eggs. Put half of this mixture in the bottom of a pudding-dish, lay in the fowls, and spread the remainder of the rice over the top. Bake until a light brown.

Rice is a good article to experiment with. It is good in so many different ways, and combines so readily with almost any flavor that its possibilities are almost inexhaustible.

MAIDA McL.

**HOW HE KNEW THAT HE WAS CURED**

A DOG CALLED AS A WITNESS TO A CURE OF DYSPEPSIA

"How do I know I was cured? Well, it's this way," said the man to the reporter. "I used to come home from work feeling uglier than sin. When the dog saw me coming he'd put his tail between his legs and sneak under the back porch. When I went into the kitchen the cat dived under the cook-stove, and as soon as the children heard my voice they'd stop their play and go and sit on the stairs and talk in whispers. My wife looked at me anxiously, not daring to speak until I spoke first and she could judge what mood I was in. When we sat down to table the little ones could hardly eat for fear of me. That's the way I was while I was suffering from 'stomach trouble.'



"Now when I go home the dog comes bounding down the road, barking a welcome. Little Dick and Annie race to see who'll get to father first, and the wife stands at the door waiting, with all her heart in her eyes. The children laugh and chat through supper, and romp afterward till bedtime, and their little voices are music to me. If you don't believe me, ask my family. No, ask the dog, he's absolutely impartial."

"And you attribute your cure to the use of Dr. Pierce's Golden Medical Discovery?" said the reporter.

"What else can I attribute it to?" was the reply. "I doctored for years without any benefit. I tried everything I could hear of, but I kept getting worse. One day my wife read a testimonial to a cure of a case which was like mine. The writer said that 'Golden Medical Discovery' had made a new man of him. She got a bottle unbeknown to me, and I was mad at her, too, for wasting the money. I let the bottle stay awhile and wouldn't touch it. One day I thought I might as well use the stuff up, so I began. I felt better after using that bottle, and got some more, and I kept it up until I felt like a well man. I gained fifteen pounds in two months, and I never felt better in my life than I do now. Of course I give the credit to Dr. Pierce's Golden Medical Discovery. If it's a coincidence I advise every one that wants a similar coincidence to use the 'Discovery.'"

**A GREAT SUFFERER**

"I was a great sufferer from dyspepsia for over two years, and I was a complete physical wreck," writes Mr. Preston F. Fenstermacher, of Egypt, Lehigh Co., Penna. "Had many torturing, gnawing and aching pains—I think that about all that a dyspeptic has or ever could have. I also suffered much with constipation. I tried many different medicines which were recommended to cure the trouble, but these only made me worse, and my condition was more sluggish and weak than before. It seemed that I was getting worse all the time. At the same time my stomach was so weak that the least and easiest kind of food to digest would get sour in my stomach, and I had such a weak and debilitated appearance that it seemed as if I had hardly any blood in my whole body. Muscles were soft and flabby, circulation poor and slow. Suffered greatly from cold hands and feet. I wrote to a number of medical firms for medicine and advice, and most of them asked of me a large sum of money to cure me, but this I could not afford. At last I came across an advertisement of Dr. Pierce's. I read it through and thought to myself this firm must have some sympathy with suffering humanity. I wrote to them for a question-list blank, which I filled out and returned to them, stating my symptoms and pains. To my great surprise I received by return mail the best and most substantial advice that I ever before read. This advice gave me the greatest confidence in the World's Dispensary Medical Association, even so great that I at once left off all former remedies and tried Dr. Pierce's Golden Medical Discovery and 'Pleasant Pellets.' I used about eight vials of the 'Pellets' and ten bottles of the 'Discovery,'

which brought me back to my former state of health."

Dr. Pierce's Golden Medical Discovery cures diseases of the stomach and other organs of digestion and nutrition. When the stomach is cured diseases which seem remote from the stomach are cured with it, because many forms of disease affecting the lungs, heart, liver, kidneys and other organs have their origin in a diseased condition of the stomach and the digestive and nutritive system. What is known as "weak stomach" invariably brings other organs down to a similar level of weakness. The body is sustained by food. All its strength comes from food after it has been digested and assimilated. When the digestive and assimilative powers fail the body fails of proper nutrition, and the loss of strength which ensues is felt proportionately by each organ of the body, because each organ of the body is only partly nourished. When Dr. Pierce's Golden Medical Discovery cures the diseased stomach and re-establishes the digestive and assimilative power the starved and weakened organs at once begin to be nourished back into strength.

**A VERY BAD CASE**

"I wish to tell you of the great benefit I have received from the use of Dr. Pierce's Golden Medical Discovery," writes Mr. G. B. Bird, of Byrnside, Putnam Co., West Va. "It cured me of a very bad case of indigestion, associated with torpid liver. Before I began the use of 'Golden Medical Discovery' I had no appetite; could not sleep, nor work but very little. The little that I ate did not agree with me. I was constipated, and life was a misery to me. I wrote to Dr. Pierce, giving the symptoms, and asked for advice. He advised me to try the 'Golden Medical Discovery,' so I began the use of it, and after taking four bottles I felt so well that I went to work, but soon got worse, so I again began the use of it and used it about eight weeks longer, when I was permanently cured. I took in all twelve bottles of the 'Discovery' and some of Dr. Pierce's Pleasant Pellets in connection with the 'Discovery.'"

Sick people are invited to consult Dr. Pierce by letter, free. All correspondence strictly private and sacredly confidential. Address Dr. R. V. Pierce, Buffalo, N. Y.

It sometimes happens that the desire to make a little more profit tempts a dealer to offer some less meritorious medicine as "just as good" as Doctor Pierce's Golden Medical Discovery. The customer will be quite safe in saying that there is nothing else just as good as the "Discovery" for his condition. It can be relied on and has a record behind it of authentic cures which no similar medicine can duplicate.

**BETTER THAN GOLD**

is wisdom, and the choicest of all wisdom is that which teaches how we may live a healthful and happy life. Dr. Pierce's Common Sense Medical Adviser points the path of health so plainly that no wayfarer need err therein. It deals with the great topics of human origin and reproduction in a common-sense way. It tells the plain truth in plain English. This great book, containing 1008 large pages, with durable cloth binding, is sent free on receipt of 31 one-cent stamps to pay expense of mailing only. If satisfied to have the book in paper cover, send only 21 stamps for expense of mailing. Address **Dr. R. V. Pierce, Buffalo, N. Y.**

**NEW FRENCH POSTAGE-STAMPS**

France is preparing her new postage-stamp, which is to be a memorial of the Exhibition. The day it opens to the public that stamp, for ten, fifteen, twenty, twenty-five and thirty centimes, will be on sale and in use everywhere. It is not as if the label showed the head of the president, as in the case of America; or of a sovereign, as in empires and kingdoms. The design was insuggestive of date and independent of time, so long as the republic lasted. But the Exhibition is to make much that was old obsolete. The new stamp will show the republic, a seated figure, holding a tablet, on which is written, "Droits de l'homme." On a cartouche, wreathed with laurels, will be inscribed the value of the stamp, and the legend "Republique Francaise" will be read underneath.—London News.

**LOW RATE HOME SEEKERS' EXCURSIONS**

The Missouri Pacific Railway and Iron Mountain Route are now running a series of excursions to the West and Southwest, tickets on sale April 17th, at very low rates. Maps, folders, time-cards and illustrated pamphlets on the various states mailed free on application to H. C. Townsend, G. P. and T. Agent, St. Louis.



## FARM SELECTIONS

### SMUT OF OATS

THE spores gain an entrance during the germination of the seed. If the spores sticking to the surface of the grain can be killed the disease can be almost wholly prevented. To kill the spores the seed is soaked in hot water or in certain chemicals. The hot-water treatment is the cheapest, but on small quantities it is not so convenient of application as the other method. To apply the hot-water treatment, soak the seed-oats in water heated to a temperature of 133 degrees Fahrenheit. The grain, in about half-bushel quantities, is placed in a sack, wire-netting cage or other closed receptacle allowing free access of water and plunged in the water, which should be in a large tub, kettle or vat. It should be kept in the water, being meantime rotated and plunged, about ten minutes. A thermometer should be at hand constantly, for if the temperature is too high the seed will be injured, and if too low the smut will not be killed. It is a good plan to dip the seed first into water about 110 degrees to 120 degrees Fahrenheit so that the hotter water will not be so much cooled by the process. After that treatment the seed is spread out on a floor to dry.

The second method for treating oat-smut is to soak the seed for twenty-four hours in a solution of liver of sulphur, one and one half pounds to twenty-five gallons of water. Care should be taken to completely wet all the grains. The solution should be kept in a wooden vessel.—Kansas Experiment Station.

### THE PROFITS OF MARKET-GARDENING

Numbers of inquiries come to the editors of horticultural and agricultural newspapers of gardening profits that may be made out of growing fruits and vegetables for market. Much attention is paid to the character of the soil, the climate and the adaptability of varieties to these conditions; but one essential is over all, and that is the marketing of fruits and vegetables after they have been raised. Even when there are markets convenient a person may be wholly ignorant of the methods of marketing. It takes nearly as much art to know how to sell as it does to know how to raise the article in the first place. In brief, the success of any proposed market-gardening plan depends as much on the man himself as on the natural conditions of soil and climate.—Meehan's Monthly.

### TOADS IN THE GARDEN

Have you learned to value the full worth of toads in your warfare against insects? Do you instruct the boys that they are genuine friends, not foes? If not, learn the lesson from the farmers of France. In many rural communities the Frenchmen put up boards with this inscription: "Toads help agriculture; destroy twenty to thirty insects each hour. Don't kill toads." And this of birds: "Birds. Each department of France loses yearly millions of francs by the injury done by insects. Don't kill the birds."—Vick's Magazine.

## RECENT PUBLICATIONS

### BOOKS NOTICED

THE A B C OF FERRET CULTURE. By N. A. Knapp, Rochester, Ohio. A treatise on the breeding, feeding, care and management of ferrets. Price 12 cents.

HIS LORDSHIP, THE BELGIAN HARE. By A. M. Lambert. Treatise on the breeding, care, management and development of the most popular of all rabbits. Price 25 cents. Published by Star Printing Co., Jacksonville, Ill.

VEGETABLE-GARDENING. A manual on the growing of vegetables for home use and marketing. By Samuel B. Green, professor of horticulture in the University of Minnesota, St. Anthony Park, Minn. Second edition. Revised, 8vo., 240 pages, 122 illustrations.

### CATALOGUES RECEIVED

John Z. Faust, Mercersburg, Pa. Illustrated catalogue of thoroughbred poultry.

Edward Gillett, Southwick, Mass. Illustrated catalogue of hardy ferns and flowers, shrubs, roses, etc.

McLaughlin Bros., Columbus, Ohio. Illustrated catalogue of imported French Coach and Percheron stallions.

The Link-Belt Machinery Co., Chicago, Ill. Illustrated descriptive circular of the Link-belt box water elevator.

C. C. Shoemaker, Freeport, Ill. Almanac and poultry annual of best strain of imported and domestic fowls, and incubators and brooders.

W. A. Manda, South Orange, N. J. Illustrated catalogue from the Universal horticultural establishment describing new, rare and beautiful seeds and bulbs.

Cash Supply & Mfg. Co., Kalamazoo, Mich. Catalogue of vehicles, harness, farm implements, horse-powers, corn-shellers, feed-cutters, feed-cookers, engines, boilers, many farm specialties, etc.

# 1900 "ALPHA-BABY" CREAM SEPARATORS

Great as has been the previous superiority of the "Alpha" De Laval machines to other separators, the 20TH CENTURY "Alpha" developments place them still further above the possibilities of attempted competition from anything else in the shape of a cream separator.

### NEW STYLES, CAPACITIES AND PRICES.

Old Style "Hollow-Bowl" Baby No. 1,	150 lbs.,	- \$50.00
Old Style "Strap" Humming-Bird,	175 lbs.,	- 50.00
Improved "Crank" Humming-Bird,	225 lbs.,	- 65.00
Improved Iron-Stool Baby No. 1,	325 lbs.,	- 100.00
Improved Iron-Stool Baby No. 2,	450 lbs.,	- 125.00
Improved High-Frame Baby No. 2,	450 lbs.,	- 125.00
Improved High-Frame Baby No. 3,	850 lbs.,	- 200.00
Improved Dairy Steam-Turbine,	850 lbs.,	- 225.00

Send for "20th Century" catalogue.

## THE DE LAVAL SEPARATOR CO.

RANDOLPH & CANAL STS., CHICAGO. General Offices: 1102 ARCH STREET, PHILADELPHIA.  
74 CORTLANDT STREET, NEW YORK. 327 COMMISSIONERS ST., MONTREAL.  
103 & 105 MISSION ST., SAN FRANCISCO.

## A \$25.00 MAUSER RIFLE FOR ONLY \$10.00

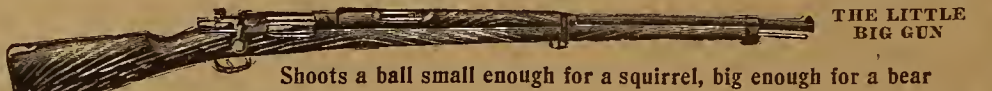

Shoots a ball small enough for a squirrel, big enough for a bear

These are the genuine 5-shot repeating Spanish Mausers captured from the Spanish at Santiago. Our agent has purchased the entire lot, with millions of cartridges, at a price which enables us to make this low offer. For \$10 we furnish Mauser rifles, in complete serviceable condition, with graduating sights and cleaning rods. These guns have all been cleaned and examined at our expense, and are guaranteed. These are not old-fashioned, obsolete rifles, but of modern pattern and improvements, with the popular sliding breech-block action, automatic shell ejecting and loading. Magazine holds 5 cartridges. We own these guns at the lowest possible figure, and we are offering them to the public at a price below what the Government were asking. They cannot be obtained now from any other source. The guns we offer are of the desirable 7 millimeter and 7.65 millimeter caliber, and weigh from 7 to 8 pounds; length of barrel, 28 to 30 inches. Ammunition for these rifles is made by the manufacturers in this country. Consequently a supply of ammunition can always be secured. We have an almost inexhaustible stock of captured ammunition which we supply at astonishingly low rates. With each gun we send a supply of cartridges. The rifle is conveniently adapted to both large and small game; the ball, being small, does not fear small game; it goes with such a terrific force (2,400 feet to the second) that it pierces the skull of a bear or buffalo and traverses the entire length of his body. By the use of the improved smokeless cartridges, it is more effective for large game than the old 50 caliber.

**SOME THINGS THE MAUSER WILL DO:** It will shoot a ball through a plate of Iron 1-2 inch thick. It will shoot through 4 feet of solid wood. With long-range sights you can shoot two miles, without using graduated sights; you can shoot point-blank 500 yards. It is accurate and true shooting to the highest degree; at 100 yards, in skilled hands, can hit a penny. THE PRICE OF THESE RIFLES HAS HERETOFORE BEEN \$25, BUT TO ADVERTISE our house we will sell a part of our stock FOR \$10, and on receipt of \$2.50, as evidence of good faith, we will ship the rifle by express, with loaded smokeless powder ball cartridges, ready for immediate use, and trust to your honor to pay the balance, \$7.50 and express charges, when you receive it and know it to be as represented and just what you want. Could anything be more fair? WE WARRANT EVERY GUN to be serviceable and in good condition and just as represented or money refunded. This is a rare chance to get an excellent rifle at less than one half price and at the same time have a valuable souvenir of the Spanish war which will increase in value as years roll by. You can easily double your money on these rifles if you want to sell. Customers who have purchased Mauser rifles report that they are highly pleased with their good qualities.

WHAT A CUSTOMER SAYS: The Mauser rifle purchased of you is all right. It is a wonderful gun; the most powerful and accurate shooter I ever saw. Have shot through 33 inches of solid hard birch wood and through 2 inches of limestone.

The Mauser is the best and most famous rifle in the world. It is making history at present with the Boers in South Africa. Every sportsman and every souvenir collector wants one of these rifles.

Address KIRTLAND BROS. & CO., Dept. M, 296 BROADWAY, NEW YORK

## Young Buckeye Walking Cultivator

Something New in the Line of Walking Cultivators, Yet the Most Practical Walker Ever Built

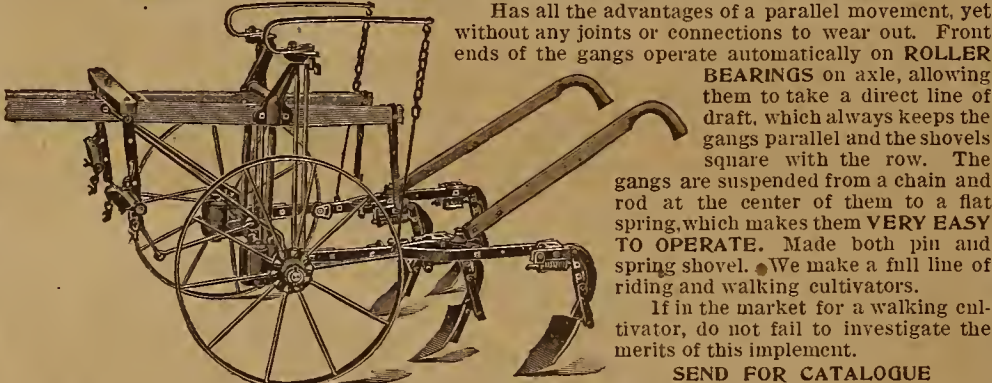

Has all the advantages of a parallel movement, yet without any joints or connections to wear out. Front ends of the gangs operate automatically on ROLLER BEARINGS on axle, allowing them to take a direct line of draft, which always keeps the gangs parallel and the shovels square with the row. The gangs are suspended from a chain and rod at the center of them to a flat spring, which makes them VERY EASY TO OPERATE. Made both pin and spring shovel. We make a full line of riding and walking cultivators.

If in the market for a walking cultivator, do not fail to investigate the merits of this implement.

SEND FOR CATALOGUE

P. P. MAST & CO., No. 17 Canal Street, SPRINGFIELD, OHIO

## FREE SILK DRESS

Here is an honest advertisement. No beating around the bush. You can get full 10 to 15 yards of beautiful silk, Black, brown, blue, green or pink, in light or dark shades, and a beautiful mercury diamond breast pin for selling our remedies. We talk plain English & guarantee to do exactly as we say. We don't ask a cent. If you agree to sell only 6 boxes of our Positive Corn Cure at 25 cts. a box, we send you the silk by mail. When sold you send us the \$1.50 and we send you the solid gold laid mercury diamond breast pin, together with our offer of a handsome silk dress, same day money is received. We make this extraordinary inducement to secure honest people and prove our Corn Cure the best on earth. There is no chance about it. If you comply with the offer we shall send you; the silk dress (full 10 to 15 yards, any color you desire) will be given absolutely free. Don't pay out money for a handsome dress while you can get one free for selling our remedies. Address at once, MANUFACTURERS' SUPPLY DEPT., 60, 65, 5th Ave., N. Y. City.

**BABY CARRIAGES** Shipped C.O.D. to anyone. Combination Go-Carts anyone. Direct from factory at lowest wholesale prices. Dealers large profits saved. No money in advance. \$18 Carriage, \$9.00 | \$5.00 Carriage, \$3.00 | \$12 " \$6.00 | GO-CARTS from \$3.00 up. Send for free illustrated catalog and special offer. CASH BUYERS' UNION, 164 West Van Buren St., B-7, Chicago, Ill.

**SPECTACLES** for wholesale, Send for catalog, Agents wanted. COULTER OPTICAL CO., Chicago, Ill.

**THE ABC of BEE CULTURE.** The only cyclopedia on bees, 466 pages and 406 illustrations. Every phase of the subject fully treated by experts. Price \$1.20. Circulars and sample copy of our semi-monthly magazine, Cleanings in Bee Culture, free if you mention this paper. THE A. I. ROOT COMPANY, Medina, O.

**CRAZY WORK** SILK REMNANTS, enough for quilt, 50c. Large package handsome colors 10c. JERSEY SILK MILL, Box 32, JERSEY CITY, N. J.

NO crop can grow without Potash. Every blade of Grass, every grain of Corn, all Fruits and Vegetables must have it. If enough is supplied you can count on a full crop—if too little, the growth will be "scrubby."

Send for our books telling all about composition of fertilizers best adapted for all crops. They cost you nothing.

GERMAN KALI WORKS, 93 Nassau St., New York.

## TO THE AMERICAN SUMMERLAND

"The Overland Limited," VIA UNION PACIFIC

ONLY THREE NIGHTS BETWEEN CHICAGO AND CALIFORNIA

"The Overland Limited" runs every day in the year and makes many hours quicker time between Missouri River and San Francisco than any other line.

Finely equipped with Double Drawing-Room Palace Sleepers, Buffet Smoking and Library Cars, with Barber-Shop and Pleasant Reading-Rooms.

Dining-Cars, Meals a-la-carte. Pintsch Light, Steam Heat. For tickets, advertising matter, and full information, call on or address

A. G. SHEARMAN, Gen. Agt. Pass. Dept. U. P. R. Co. Room 36, Onrew Bldg., Cincinnati, Ohio.

### THE WHEEL OF TIME

for all time is the

## Metal Wheel.

We make them in all sizes and varieties, TO FIT ANY AXLE. Any height, any width of tire desired. Our wheels are either direct or stagger spoke. Can FIT YOUR WAGON perfectly without change.

**NO BREAKING DOWN.** No drying out. No resetting tires. Cheap because they endure. Send for catalogue and prices. Free upon request.

Electric Wheel Co. Box 96 Quincy, Ill.

## CLEARING SALE

6000 new '99 model Bicycles carried over must be SACRIFICED AT ONCE. \$11.75

SECOND-HAND wheels, good as new, over 50 makes and models \$3 to \$10

Swell 1900 Models, \$11 to \$20 HIGHEST GRADE GUARANTEED.

WE SHIP TO ANY ONE ON APPROVAL AND TRIAL BEFORE PAYMENT. One RIDER A CENT in each town can obtain FREE USE of sample wheel to ride and exhibit. Write for ART CATALOGUE, BARGAIN LIST AND OUR SPECIAL OFFER.

MEAD CYCLE CO., Dept. 43 B, Chicago.

## The Most Cider

of the BEST QUALITY and the PUREST form can be secured from a given quantity of apples by the use of the

### HYDRAULIC CIDER PRESS

The only press awarded medal and diploma at World's Fair. Get our free illustrated catalogue before buying.

HYDRAULIC PRESS MFG. CO., 6 Main St., Mt. Gilend, Ohio.

## CRESCENT FENCE

will last a lifetime. Composed of all large wires and steel stays. Catalogue and prices free. Address

THE C. M. FENCE STAY CO., 11 Canal St., Covington, Ohio.

## ALL STEEL UP-TO-DATE LAWN FENCE

50 DESIGNS, CHEAPER THAN WOOD FENCE. CATALOGUE FREE. UP-TO-DATE MFG. CO. 371 N. 10th STREET, TERRE HAUTE, IND.-U.S.A.

## "OLD GRIMES IS DEAD,"

but if he used Page Fence, it is standing yet.

PAGE WOVEN WIRE FENCE CO., ADRIAN, MICH.

## Fence Machine

That weaves 50 to 100 rods per day out of barbed, cable, crimped, coiled or smooth wire. Machines Guaranteed. Catalogue Free. Hoosier Boy Fence Co., Indianapolis, Ind. Dept. 23

## M. M. S. POULTRY FENCE

Half cost of Netting. Requires few posts, no rails. Best Hog, Farm, Yard, Cemetery Fences. Freight paid.

KANSAS STEEL & WIRE WORKS, KANSAS CITY, MO.

## SILVERWARE FREE

### 48 PIECES

This handsome and valuable Silverware will be given free to every person who will help us to quickly advertise Howard's Vegetable Pills, a sure and safe cure for Constipation, Indigestion and Torpid Liver. We have contracted with a leading silverware Co. for large quantity of these goods and give them away to introduce our pills. You can take advantage of this offer. Write today and we will send you six boxes of our pills postpaid. Sell them at 25c. each and remit us \$1.50 and we will send you at once 12 tea spoons together with our offer of 12 forks, 12 knives and 12 table spoons same day money is received. The silverware is made with latest pattern and fully warranted to wear for years. HOWARD DRUG CO., 38 Dearborn St., CHICAGO



# One Year's Free Trial

We will ship a Cornish Piano or a Cornish Organ anywhere upon the distinct understanding that if it is not satisfactory to the purchaser after twelve months' use, we will take it back. Could anything be fairer, anything more liberal than this unique plan of selling.

This is the most liberal offer ever made. It would be impossible for us to make it if it could not be supported by the strongest evidence of our absolute reliability. We guarantee every instrument for twenty-five years, and we back up each purchase with a personal guarantee endorsed by a business reputation of fifty years, and property worth over a million dollars.

FOR FULL PARTICULARS OF THIS WORLD FAMED CORNISH PLAN, send for our New Souvenir Catalogue—a work of art with handsome colored illustrations. We send it absolutely free.

**Cornish Pianos and Organs.**

**\$25 and upwards**

Over a Quarter of a Million Satisfied Customers.

A prompt response to this advertisement will secure a special discount from list prices of \$10 on an organ, and \$20 on a piano.

With every Cornish Piano we send a Cornish Patent Musical Attachment which correctly imitates the Harp, Guitar, Banjo, Mandolin, etc. This can only be had with the Cornish Piano.

For references, consult your bank, our bank, any bank.

**CORNISH & COMPANY**  
(Established 50 Years)  
Washington, N. J.

**\$155 and upwards**

## For Any Soil

For soft or rocky ground, the harrow that does the best work and draws easiest is HENCH and DROMGOLD'S riding or walking Spring Tooth Wheel Harrow.

Send for free catalogue of best harrows, cultivators, corn planters, grain drills, etc.

**HENCH & DROMGOLD, York, Pa.**

## BULL-STRONG

Seven styles. Any height desired. Made of Colled Spring Steel Wire, galvanized. The coil makes it self-regulating. It's CHICKEN-TIGHT.

Our Prices will surprise you. We sell direct to the farmer at lowest wholesale Anti-Trust Prices as we belong to no combination or trust. Catalogue and prices free for the asking.

**COILED SPRING FENCE CO.,**  
Box 18 Winchester, Indiana.

## FIRE, WEATHER, and Lightning Proof

Black, painted, or galvanized metal ROOFING and siding; (brick, rock or corrugated)

**Metal Ceilings and Side Walls** in elegant designs. Write for Catalogue.

The Penn Metal Ceiling and Roofing Co., Ltd.,  
23d & Hamilton Sts., Phila., Pa., or 24 Harcourt St., Boston, Mass.

## DON'T ROB YOUR NEIGHBOR

By buying a poor fence that will let your stock fatten on his crops. The KITSSELMAN FENCE is a satisfactory one. It insures good sleep and makes good neighbors. Free Catalogue telling how to make 100 Styles at the actual cost of the wire. Write to-day.

**KITSSELMAN BROTHERS,**  
Box 278 Ridgeville, Indiana, U. S. A.

## SPRAY PUMPS

Save your fruit and make you money. "THE DAISY" is 15 years old and 200,000 in use. Has every improvement—rubber hose, perfect nozzles and valves.

No. 1, tin, \$1.50; No. 2, iron, \$2; No. 3, all brass, \$4.

We pay express. Agents wanted. Catalogue free.

**W. M. Johnston & Co., Box 1, Canton, O.**

I Have the Smallest Breed of Dogs Known Full grown less than five inches in height. They make nice pets. One sent to any address on receipt of \$3.00.

**C. R. PERRY, MALTA, MONTANA.**

## SELECTIONS

### HORSEHIDE AND ITS USES

THE use of horsehide in razor-strops is familiar, but this is only one of many uses to which horsehide is put; it is an excellent and valuable leather.

Some parts of the hide are used for shoe-uppers, the leather produced for the purpose being called Cordovan, from Cordova, in Spain, where it was first made. Cordovan is a fine, strong, handsome leather. It formerly cost more than calfskin, but now the cost is about the same. Horsehide is used also for the manufacture of gloves and mittens and in book-binding, and there is made of it an imitation buckskin. Horsehide is used in making whip-lashes, and some parts of it are used for making shoe-strings; it is used for carriage-leather, in covering seats, and so on. Horsehide is much thinner than cowhide.

The supply of horsehide comes chiefly from cities. Some horsehides are imported from Europe, the greatest number of these coming from Russia. The finest of all horsehides come from Normandy, in France. City horsehides are commonly the best, and the best of all American horsehides are those gathered in this city. The largest and best hides come from the fine, big draft-horses used by brewers and others.

As compared with the number of cowhides and other hides tanned the number of horsehides is, of course, limited; but in the aggregate it is large, and there is a demand for all leather produced.—New York Sun.

### TRADE WITH JAPAN

Japanese imports are rapidly decreasing under her new tariff, which went into effect at the beginning of 1899, while her exports continue increasing. The total imports of Japan during the first seven months of 1899 were 111,531,744 yen, against 177,074,378 yen for the corresponding months of the previous year, while the exports at the same time were 106,770,121 yen, against 82,188,791 yen in the corresponding months of the previous year, so that while her exports have increased twenty-five per cent her imports have decreased. This marked reduction in Japanese imports suggests an inquiry as to how great an effect it is having upon her purchases from the United States. An examination of our own exports to Japan, made during the seven months covered by the Japanese figures, shows a reduction of only 18.2 per cent in our sales to Japan, against thirty-seven per cent in those of the world at large, as shown by her own statement of imports.—Scientific American.

### WHAT IS A WORKING-DAY?

What is the ruling of the court in regard to a "working-day" under a contract requiring to complete the work within a specified number of days? Is a day in which the weather is unfit for a man to work out of doors held as a working-day in a contract of the above character?

The ruling of the court in cases of the foregoing character has uniformly been that a "working-day" is one in which the weather will permit work to be done. The court interprets the wording of such a contract in a reasonable manner, holding that where contract for outside work is being executed the elements must be taken into consideration. A day in which the weather is unfit for a man to work out of doors is not a "working-day" under a contract involving outside work.—Legal Bureau.

### THE POPULATION OF EUROPE

A scientific statistical work just published fixes the population of Europe at 381,000,000, an increase of 79,000,000 since 1870, or an annual increase of about 3,000,000. The average density of this population is given as thirty-nine inhabitants for every five eighths of a square mile. Belgium presents the most thickly settled state, with two hundred and twenty-four inhabitants for every square kilometer. Then follows Holland with one hundred and fifty-two, Great Britain with one hundred and twenty-seven, Italy with one hundred and eleven, the German empire with ninety-seven, Switzerland with seventy-six, Denmark with fifty-eight, etc. The least crowded countries in Europe are Russia with thirty-one, Sweden with eleven and Norway with six inhabitants for each square kilometer.

# SILVER-PLATED BUTTER-KNIFE AND SUGAR-SHELL

Premium No. 325

This butter-knife and sugar-shell are of the same pattern and the same quality as the silver-plated teaspoons described below. Fully guaranteed to give satisfaction or money refunded.

The base of each is of high-grade nickel-silver, which is then plated with the full STANDARD amount of pure coin-silver. The ware is white clear through and will not turn brassy, corrode or rust. No more serviceable ware made.

**ANY INITIAL LETTER**

Each piece is engraved free of charge with an initial letter in Old English; only one letter will be engraved on each piece.

**GUARANTEE**

We guarantee every piece of this ware to be exactly as it is described and to give entire satisfaction or money refunded.

We Will Send Both the Butter-knife and Sugar-shell, and the Farm and Fireside One Year, for only

## 60 Cents

(When this offer is accepted the club-raiser may have either the regular cash commission or the name may be counted in a club)

Both the butter-knife and sugar-shell given as a reward for a club of FOUR yearly subscriptions to the Farm and Fireside. Address

**FARM AND FIRESIDE,**  
SPRINGFIELD, OHIO

# Six Silver-plated Teaspoons.....

Given for a club of FOUR

These teaspoons can be used in cooking, eating and medicines the same as solid silver. They will not turn brassy, corrode or rust.

**GUARANTEE**

We absolutely guarantee these spoons to be exactly as described and to give entire satisfaction or money refunded.....

Postage paid by us

Premium No. 60

## Pure Coin-silver Plating

The base of these spoons is solid nickel-silver, which is the best white metal known for the base of silver-plated ware, because it is so hard and so white that it will never change color and will wear a lifetime. On this base is plated the standard amount of pure coin-silver.

**ANY INITIAL LETTER** Each spoon is engraved free of charge with an initial letter in Old English. Only one letter on a spoon.

We will send a set (six) of these teaspoons, and the Farm and Fireside one year, for 75 Cents (When this offer is accepted the club-raiser may have either the regular cash commission or the name may be counted in a club)

A set of Teaspoons given free for a club of FOUR yearly subscriptions

Address **FARM AND FIRESIDE, Springfield, Ohio**

## Rife Hydraulic Engine

Pumps water without any attention or expense for IRRIGATION.

Big Increase in Crops Independent of Rain-Higher Prices. Early Crops.

**POWER SPECIALTY CO., 126 Liberty Street, NEW YORK.**

## BICYCLES CHEAPER THAN EVER

from the OLD RELIABLE CO. Great Special Sale. Nearly 8000 Bicycles, every one a BARCAIN. Must be sold. All makes, 2nd h'ds, \$5 and up. Late Models new \$11.50 and up. Shipped anywhere on approval. A few more good agents wanted. Big Money. Write to-day for big list and special offers never before approached. **BROWN-LEWIS CO.** Dept. (J) Chicago, U.S.A.

**\$1,400 MADE** at home in 8 months. Particulars 4c. **UNION OIL CO., LIMA, OHIO.**

## AGENTS WANTED

FOR THE ENLARGED 1900 PEERLESS ATLAS AND PICTORIAL GAZETTEER OF THE WORLD...

Now ready. Over 300 Colored Maps and beautiful Illustrations from Photographs. Sells at sight, the superb NEW FEATURES including Large Map of SOUTH AFRICA, illustrated account of the Boers and their country and causes of the war, Large Folding Maps of the Philippines, Pacific Ocean, Cuba and Alaska. Also Large Map of China and the Far East. Map and full description of Nicaragua and Panama canals, etc. Low price. Agents are positively clearing from \$20 to \$50 a week. You can do the same. Write for particulars (stating experience if any) and we will tell you how to do it. Address

**The CROWELL AND KIRKPATRICK CO., Springfield, Ohio**



# 40 Cent Patterns for 10 Cents

We Will Send Any TWO PATTERNS, and This Paper One Year, for 40 CENTS

(When this offer is accepted the club-raiser may have either the regular cash commission or the name may be counted in a club)

These patterns retail in fashion bazaars and stores for twenty-five to forty cents each, but in order to increase the demand for our paper among strangers, and to make it more valuable than ever to our old friends, we offer them to the lady readers of our paper for the low price of only 10 Cents Each.

Full descriptions and directions—as the number of yards of material required, the number and names of the different pieces in the pattern, how to cut and fit and put the garment together—are sent with each pattern, with a picture of the garment to go by. These patterns are complete in every particular, there being a separate pattern

for every single piece of the dress. All orders filled promptly.

For ladies, give BUST measure in inches. For SKIRT pattern, give WAIST measure in inches. For misses, boys, girls or children, give both BREST measure in inches and age in years. Order patterns by their numbers.

Satisfaction guaranteed or money refunded.

To get BUST and BREST measure, put the tape-measure ALL of the way around the body, over the dress, close under the arms.

Special price of each pattern 10 cents.

Postage one cent EXTRA on skirt, tea-gown and other heavy patterns.

## FREE We will give any THREE of these patterns for FREE TWO yearly subscriptions to Farm and Fireside FREE

Address FARM AND FIRESIDE, Springfield, Ohio



No. 7886.—BOYS' BLOUSE. 10 cents. Sizes, 2, 4, 6, 8 and 10 years.

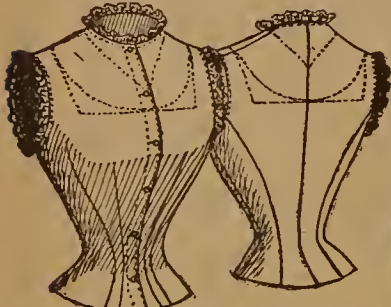

No. 7921.—LADIES' CORSET-COVER. 10c. Sizes, 32, 34, 36, 38, 40, 42 and 44 inches bust.

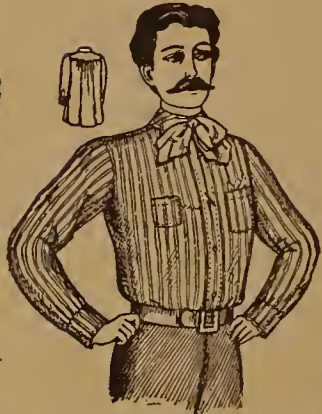

No. 7873.—MEN'S OUTFIT-SHIRT. 10 cents. Sizes, 34, 36, 38, 40, 42 and 44 inches breast.

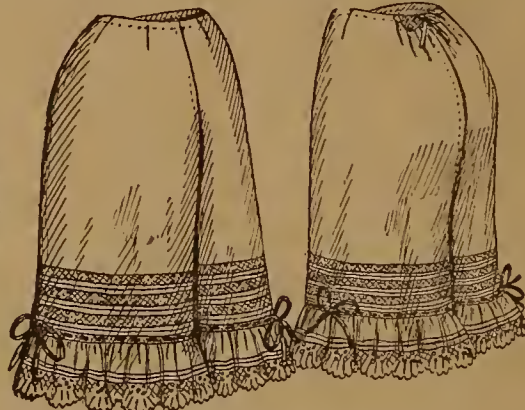

No. 7918.—LADIES' DART-FITTED DRAWERS. 10c. Sizes, 22, 24, 26, 28, 30 and 32 inches waist.



No. 7884.—LADIES' SHIRT-WAIST, WITH PLAIN OR PLAITED BACK. 10 cents. Sizes, 32, 34, 36, 38, 40 and 42 inches bust.



No. 7929.—GIRLS' TUCKED BLOUSE COSTUME. 11 cents. Sizes, 4, 6, 8, 10 and 12 years.



No. 7937.—BOYS' VESTEE KILT SUIT. 10c. Sizes, 2 and 4 years.



No. 7985.—GIRLS' TUCKED COSTUME. 11 cents. Sizes, 6, 8, 10 and 12 years.



No. 7859.—BOYS' SHIRT-WAIST. 10 cents. Sizes, 4, 6, 8, 10 and 12 years.



No. 7856.—LADIES' PRINCESS WRAPPER. 11 cents. Sizes, 32, 34, 36, 38, 40, 42, 44 and 46 inches bust.



No. 7905.—GIRLS' COSTUME. 11c. Sizes, 6, 8, 10 and 12 years.



No. 7910.—LADIES' SIX-GORED SKIRT, TO BE GATHERED OR BOX-PLAIED IN BACK. 11 cents. Sizes, 22, 24, 26, 28, 30, 32 and 34 inches waist.

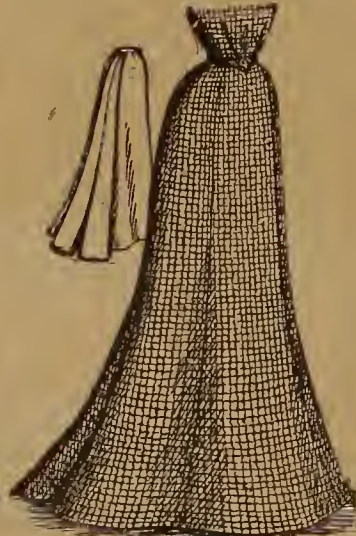

No. 7919.—LADIES' FIVE-GORED SKIRT, WITH TWO BOX-PLAITS IN BACK. 10 cents. Sizes, 22, 24, 26, 28, 30, 32 and 32 inches waist.



No. 7874.—LADIES' FANCY SHIRT-WAIST. 10 cents. Sizes, 32, 34, 36, 38, 40 and 42 inches bust.

Our New Catalogue, showing a full line of new patterns, is now ready. Free to any address.



No. 7891.—LADIES' FANCY WAIST. 10 cents. Sizes, 32, 34, 36, 38 and 40 inches bust.



No. 7887.—LADIES' SHIRT-WAIST. 10 cents. Sizes, 32, 34, 36, 38, 40 and 42 inches bust.



No. 7934.—LADIES' SHIRT-WAIST. 10 cents. Sizes, 32, 34, 36, 38, 40 and 42 inches bust.



No. 7939.—MISSSES' FOUR-PIECE SKIRT, WITH DOUBLE BOX-PLAIT IN BACK. 11c. Sizes, 12, 14 and 16 years.



No. 7931.—MISSSES' SHIRT-WAIST. 10 cents. Sizes, 12, 14 and 16 years.



No. 7930.—LADIES' FANCY WAIST. 10 cents. Sizes, 32, 34, 36, 38 and 40 inches bust.



No. 7932.—LADIES' PANEL SKIRT. 11 cents. Sizes, 22, 24, 26, 28 and 30 inches waist.

No. 7936.—LADIES' SHIRT-WAIST. 10 cents. Sizes, 32, 34, 36, 38, 40 and 42 inches bust.



# PICTURES FROM ALL COUNTRIES

A SUPREMELY INTERESTING BOOK CONTAINING NEARLY  
**300 LARGE PICTURES**

OF PEOPLE, PLACES AND POINTS OF INTEREST FROM ALL PARTS OF THE WORLD

A Book of Scenes and a Book of Travel, as each picture has with it a description giving a full explanation of the same. Many points not covered by ordinary books of travel are contained in this. In fact, the aim has been to select the most unique and most representative features of the various countries, and to avoid those things which the ordinary book is likely to describe. In the Trip Around the World which you may take by means of this fascinating book you would visit, among others, the following countries: Canada, Mexico, Africa, England, France, Spain, Portugal, Germany, Denmark, Norway, Iceland, Syria, Italy, Greece, Austria, Russia, Siberia, Holland, Belgium, Turkey, Palestine, Persia, Arabia, India, China, Japan, Australia, Switzerland, United States and South America. The places of greatest interest in these various countries are fully illustrated and described. This great work constitutes an unequalled aid to the study of geography and history, as well as a source of unending pleasure in the home. It is useful and interesting.

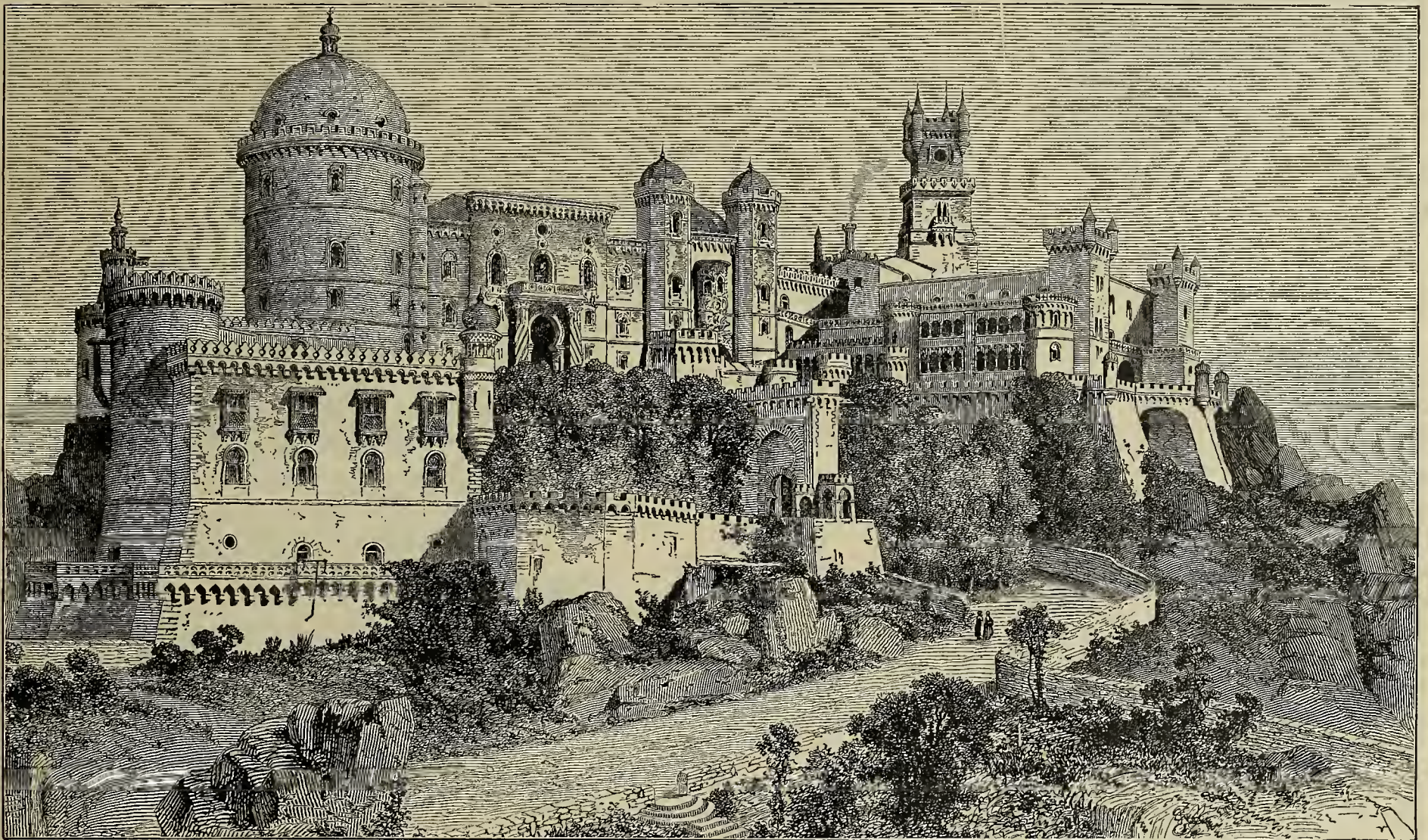

PALACE OF LA PENNA, CINTRA, PORTUGAL

The above is one of the illustrations from the book, "Pictures From All Countries." There are about 300 such fine, large pictures.

## Beautiful Pictures From All Parts of the World

The engravings in this book cost nearly \$30,000.00 to produce. They were designed to illustrate a very extensive work to be sold at \$60.00. It contains pictures of Cities, Cathedrals, Churches, Palaces, Courts and Gardens, Capitols and Public Buildings, Street Scenes, Bridges, Harbors, Caves, Tombs, Ruins, Battle-fields, Volcanoes, Rivers, Mountains and Ocean Scenery. It is entrancing in its variety and novelty. As you turn its pages you imagine yourself a veritable globe-trotter, visiting strange people in foreign countries and gazing with admiration upon many of the most magnificent formations of nature and the most noted and marvelous structures reared by man throughout all ages.

### SPECIAL LIMITED OFFER

We have about 2,000 copies of this great work which we are going to give to the subscribers to the Farm and Fireside upon the following terms:

**We Will Send the Farm and Fireside One Year, and "Pictures From All Countries," for . . . . . 35 Cents**

*(When this offer is accepted the club-raiser may have either the regular cash commission or the name may be counted in a club.)*

**This Great Book Given as a Reward for a Club of TWO Yearly Subscriptions to the Farm and Fireside.**

**SPECIAL NOTICE**—THIRTY-FIVE Cents is the clubbing price for the Farm and Fireside without a premium, and we offer this limited number of these books absolutely FREE. By ordering at once is the only sure way of being certain to get the book.

Order by Premium Number

**Address FARM AND FIRESIDE, Springfield, Ohio**



# Thrifty, Live Plants Free

**Either 4 Geraniums, or 5 Roses, or 6 Carnations, or 6 Chrysanthemums Given for a Club of TWO Yearly Subscriptions to the Farm and Fireside**

**... Or Either Collection, and the Farm and Fireside One Year, for 50 Cents ...**

By ordering many months ahead and having 25,000 of each of these collections grown especially for our use we were enabled to get them at practically the cost of production. To induce subscriptions and clubs we now offer these plants as premiums in connection with the FARM AND FIRESIDE at just what they cost us. All of the plants will be large, healthy and well rooted, and will bloom the coming season. We guarantee them to be exactly as described, to arrive in perfect condition, and to give entire satisfaction or your money cheerfully refunded.



## 4 Beautiful Geraniums

DOUBLE AND SINGLE FLOWERING

The Geranium has been wonderfully improved during the past few years. New colors, new styles and profusely blooming sorts have been developed. The collection here offered includes the latest and best varieties of this popular flower. They are unusually fine year-old plants. Order Geranium Collection by Premium No. 290.

FOUR DIFFERENT COLORS, AS FOLLOWS:

One pure snow-white, one splendid crimson-scarlet, one rich salmon, and one beautiful pink.

## 5 Ever-blooming Roses

**Wonderful New Climbing Rose.. Empress of China** This is a new Climbing Rose of the greatest excellence. It commences to bloom in May, and is loaded with its elegant blooms until December. The greatest objection to climbing Roses has been that they bloom once and then are done. But here we have a Rose that blooms continuously for over seven months of the year. It is simply wonderful. When it first opens the flower is a beautiful red, but soon turns to a lovely light pink, and it blooms so profusely as to almost hide the plant. Order Rose Collection by Premium No. 470.

THE COLLECTION OF 5 ROSES INCLUDES ALL OF THE FOLLOWING COLORS:

One Empress of China as described above, one clear bright rosy red, one bright pink, one pure white, and one rich flesh-colored. All will bloom freely during the coming season.

## 6 Chrysanthemums

ALL DOUBLE-FLOWERING

The collection here offered is made up of large, double-flowering Japanese Chrysanthemums, the direct offshoots of famous prize-winning varieties. This collection embraces all colors known to the Chrysanthemum family, and all shapes and forms, as incurved, recurved, twisted, whorled, ostrich-plumes, etc., also early and late bloomers. Order Chrysanthemum Collection by Prem. No. 558.

SIX DIFFERENT COLORS, AS FOLLOWS:

One deep golden yellow, one rose-pink with soft satin finish, one fiery red, one violet-rose with silky texture, one pure ivory-white, and one creamy white showing a tinge of pink.

**ORDER NOW.** It is almost certain that we will receive orders for more plants than the florists have agreed to furnish. Do not wait until you are ready to plant. If you do not want your plants until some later date, we will have them reserved and shipped when desired. When you order state the time you wish the plants sent. When the supply of plants is exhausted money will be refunded.

We will send EITHER the Collection of 4 Geraniums, 5 Roses, 6 Carnations, or 6 Chrysanthemums, and the Farm and Fireside One Year, for ... **50 Cents**

(No more than one collection with one yearly subscription. When the above offer is accepted the club-raiser may have either the regular cash commission or the name may be counted in a club.)

**Free** We will send either the collection of 4 Geraniums, 5 Roses, 6 Carnations, or 6 Chrysanthemums FREE for a club of TWO yearly subscriptions to the Farm and Fireside; or any two collections for a club of FOUR; or any three collections for a club of SIX, and so on. ....

Postage on the plants paid by us in each case Address FARM AND FIRESIDE, Springfield, Ohio

## 6 Fragrant Carnations

"THE DIVINE FLOWER"

Carnations are the delight of every one who has an eye for the beautiful in flowers. Whether for personal adornment or to decorate the home they are unsurpassed in their charming appearance. Being unrivaled in their delicately rich and refreshing fragrance, unequaled for brilliancy, richness and diversity of colors, unapproached for daintiness and beauty of outline, it is not to be wondered at that next to the Rose they have become the favorite flower among all classes. The collection we offer contains a fine variety of these exquisite plants. If the plants of this collection were bought singly they would cost at least 50 cents. Order by Premium No. 534.

SIX DIFFERENT COLORS, AS FOLLOWS:

One yellow, one deep crimson, one rich scarlet, one white, one light pink striped with a darker shade, and one bright rosy pink.

### HOW TO GROW

Full instructions how to plant and care for them will be sent with each box of plants.





# FARM FIRESIDE

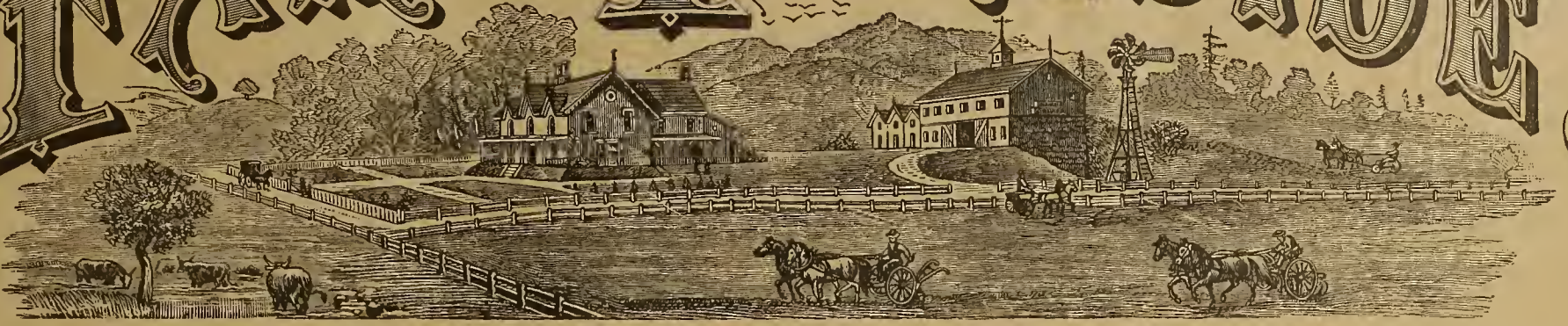

Vol. XXIII. No. 15

EASTERN EDITION

MAY 1, 1900

Entered at the Post-office at Springfield, Ohio, as second-class mail matter

TERMS { 50 CENTS A YEAR  
24 NUMBERS

## THE TOTAL ECLIPSE OF MAY 28, 1900

BY REV. J. W. GUNN

OUR near neighbor, the moon, when compared with the other heavenly bodies, is a diminutive little toy—a mere plaything. Its diameter is 2,165 miles; its distance from the earth, 237,000 miles. It hastens in its orbit around the earth at the rate of over two thousand miles an hour, making the circuit in less than twenty-eight days. It regulates the tides, mingles in an occasional love-scrape, and delights us now and then with an eclipse.

To give an idea of the comparative size of the moon to the sun, take six hundred little bodies like the moon and string them like so many silver beads, and lay them on the face of the golden sun at its equator, and your string of beads would not reach half way around by more than fifty thousand miles. (There is no sixteen to one in this estimate.) Yet a single dozen of these placed on the earth at its equator would girdle our globe. Make a diagram with the earth as the center, the orbit of the moon 237,000 miles from the earth; now go 200,000 miles beyond the moon's orbit and draw a greater circle, and if the sun were placed centrally, where the earth is in this diagram, the outer edge of the sun would be beyond this greater circle, for the diameter of the sun is 882,646 miles. Take an express-train for a trip around the sun, going twenty-five miles an hour, day and night, and it would take more than twelve years to make the journey.

We can have no conception of magnitude or space or motion till we study astronomy. To say nothing of the larger planets whose orbits are infinitely greater, the earth being 95,000,000 miles from the sun swings through its great orbit, 600,000,000 miles, every year; that is, 1,500,000 miles each day, or eighteen and one half miles at every tick of the clock. How, then, can the sun be eclipsed by so small a body as the moon? Simply by the moon being right before us, just as the smallest coin held immediately before the eye shuts out the landscape, or the almighty dollar projected into human vision "the kingdom of heaven." If the moon were slightly removed from us a total eclipse would be impossible.

The amount of light received from the sun is estimated by Todd as equal to that from 600,000 full moons. Still, we would prefer old Sol in his majesty and single blessedness to any fancied arrangement of these suggested competitors.

Missionaries tell us that when the alarm of an eclipse is given in a Hindu village the whole population turn out to avert the impending calamity. The black disk of the moon encroaching upon the bright surface of the sun is believed to be a monster gradually eating up the latter; tom-toms and gongs are violently sounded, the air is rent with screams of terror and shouts of vengeance, and all this uproar is made with the hope of scaring away the dragon from his deadly purpose. As the eclipse gradually disappears the villagers disperse amid shouts of joy, with the pleasing satisfaction that they have effected deliverance from a great public calamity. The progress of science has divested all such phenomena of the terror attached thereto by "the heathen in his blindness." The most ignorant Hindu could but be ashamed of his superstition if the astronomers beforehand had told him the exact moment when the monster would come and depart.

From the accounts which have been given of total eclipses many persons are disappointed in witnessing a partial eclipse. No approach to a total eclipse can give the slightest conception to the thing itself. The light of the sun is so intense that while the smallest part of the disk is visible the

sudden fall of temperature causes the air to feel damp and the grass wet, as from excessive dew; orange, yellow and copper tints give every object a strange appearance and startle even the most indifferent. The earth, the sea and sky assume a lurid, unnatural hue; every living thing catches the influence and covers under the great blank in the heavens. Beasts of burden lie down with their loads on the road and refuse to move on; birds in their bewilderment dash against trees and houses and fall wounded or dead; the dog drops his bone from his mouth and does not venture to pick it up till the light returns; little chickens seek immediate shelter under the mother's wing; the barnyard is forsaken for the roost; the ants halt in their track with their load and remain immovable till the shadow is past; the busy bee ceases to sip honey from the blooming flower till the return of the gracious light; bats come out of their caves as at fall of night; even the owl ventures forth as for prey, but halts at the nearest perch, nor dares utter a "too-who," but looks a veritable "where are we at?" Is it strange then that man should in a larger degree enter into these feelings of profound awe? An account was given of the total eclipse at Perpignan. The French astronomers were

ings coming over him. Suddenly the last filament of the sun's disk was covered; at that instant a deep, prolonged moan, the murmur of a great deep, arose from the vast throng; it was like the suppressed groan of a multitude witnessing an execution as the criminal swings off. But this moan did not mark the climax of high-strained feeling; the dead silence that ensued was the culminating point; not a whisper was heard, not an attitude was changed, as with the rigidity of a statue each one stood and gazed upward. So unearthly was the silence that the beat of the chronometers was heard with painful distinctness; the heart of the universe seemed to cease its throbbings; Nature had fallen into a state of syncope. For two and one half minutes this dreadful pause continued; at that moment a thread of light burst forth; the tension was at once relieved, and one loud burst of joy rent the heavens. The people could not restrain their transports of happiness; they did not care now to stay and see the final phase of the eclipse; the darkness wore off; they had beheld the crowning spectacle; they would not weaken the impression by looking at a partial obscuration, and dispersed rapidly to their homes, leaving the astronomers to continue their observations quite alone.

Many curious and interesting stories and incidents are told concerning the effect of eclipses upon individuals. Kings have abdicated their thrones, warriors have abandoned the siege or surrendered in disgrace, and the plighted vows of lovers been broken.

Eclipses more than anything else demonstrate the perfect regularity of the motions of the heavenly bodies. The chance of a person witnessing in his lifetime a total eclipse in any given spot on the earth's surface is exceedingly small, for there are only sixty-seven to seventy in a century; the last in the United States was August 7, 1869, which extended over a line from Sioux City, Iowa, to Knoxville, Tennessee, and was observed by astronomers at Springfield, Illinois, and Shelbyville, Kentucky. The coming eclipse, May 28, 1900, will be central at New Orleans at 7:30 A. M., and at Norfolk, Virginia, at 8:50. The line of totality is nearly sixty miles wide, and Mobile, Alabama; Columbus, Macon, Milledgeville, Georgia; Columbia, South Carolina; Raleigh, North Carolina, and many intermediate points are along the line. The partial eclipse, which extends many miles on either side of the line of totality, varies in extent with the distance from the center, and may be witnessed by half the inhabitants of the United States.

There will not be another total eclipse in our country till June, 1918, when the line of eclipse will run from Oregon to Florida.

[CONCLUDED ON PAGE 6 OF THIS ISSUE]

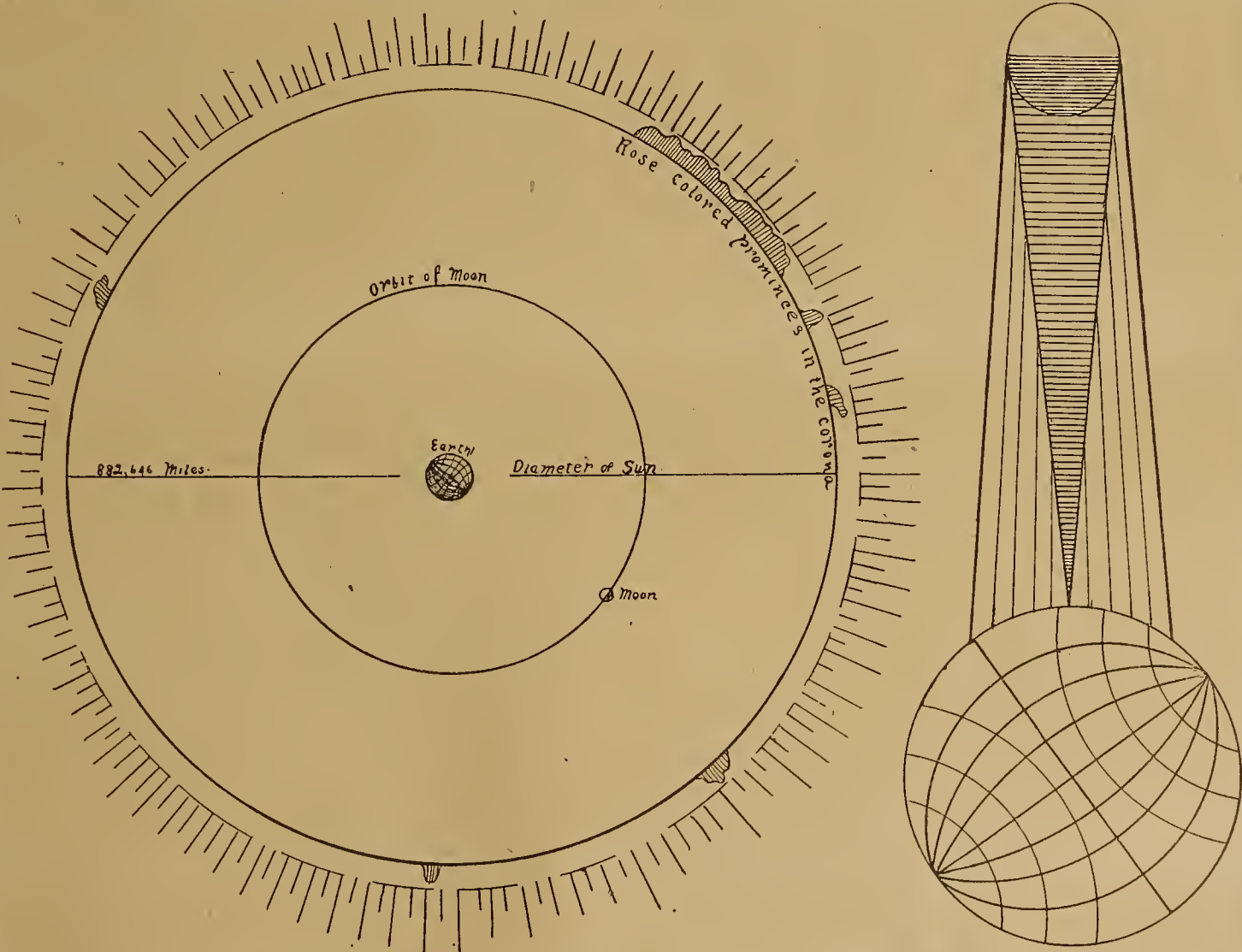

darkness is by no means alarming. The gradual creeping of the moon over the disk of the sun gives no preparation for the grand final effect of the frightful and sudden darkness; when the last ray is gone then comes "a darkness that may be felt." In calling a total eclipse a darkness that may be felt there is no exaggeration; everything in Nature sympathizes with your feelings, and intensifies them in awe and mysterious apprehension. The darkness is so intense that the brighter stars and planets are seen;

on the ramparts with their instruments, the soldiers on one side and a dense crowd of people on the other. The moment the people, with smoked glasses to their eyes, marked the first indentation on the sun's disk they raised a deafening shout of applause. The moon gradually crept over the face of the sun, and for a time there was nothing but the usual loquacity of the French people. As the eclipse drew toward totality the murmur of thousands of voices increased, each telling his friends of the strange feel-



## FARM AND FIRESIDE

PUBLISHED BY

THE CROWELL &amp; KIRKPATRICK CO.

OFFICES:

147 Nassau Street,  
New York CitySpringfield,  
Ohio204 Dearborn Street,  
Chicago, Illinois

Subscriptions and all business letters may be addressed to "FARM AND FIRESIDE," at either one of the above-mentioned offices; letters for the Editor should be marked EDITOR.

## TERMS OF SUBSCRIPTION

One Year - (24 Numbers) - 50 Cents  
Six Months - (12 Numbers) - 30 Cents

The above rates include the payment of postage by us. All subscriptions commence with the issue on press when order is received.

Subscribers receive this paper twice a month, which is twice as often as most other farm and family journals are issued.

**Payment**, when sent by mail, should be made in Express or Post-office Money-orders, Bank Checks or Drafts. WHEN NEITHER OF THESE CAN BE PROCURED, send the money in a registered letter. All postmasters are required to register letters whenever requested to do so. DO NOT SEND CHECKS ON BANKS IN SMALL TOWNS.

**Silver**, when sent through the mail, should be carefully wrapped in cloth or strong paper, so as not to wear a hole through the envelop and get lost.

**Postage-stamps** will be received in payment for subscriptions in sums less than one dollar, if for every 25 cents in stamps you add one-cent stamp extra, because we must sell postage-stamps at a loss.

The date on the "yellow label" shows the time to which each subscriber has paid. Thus: May 1900 means that the subscription is paid up to May 1900; Jun 1900, to June, 1900, and so on.

When money is received, the date will be changed within four weeks, which will answer for a receipt.

When renewing your subscription, do not fail to say it is a renewal. If all our subscribers will do this, a great deal of trouble will be avoided. Also give your name and initials just as now on the yellow address label; don't change it to some other member of the family; if the paper is now coming in your wife's name, sign her name, just as it is on the label, to your letter of renewal. Always name your post-office.

## The Advertisers in This Paper

We believe that all the advertisements in this paper are from reliable firms or business men, and do not intentionally or knowingly insert advertisements from any but reliable parties; if subscribers find any of them to be otherwise we should be glad to know it. Always mention this paper when answering advertisements, as advertisers often have different things advertised in several papers.



IN THE "North American Review" for April is a timely article on "Mistaken Sympathy with Republics," by Thomas G. Shearman. He says, in part:

"The American idea of a republic is that of a state in which all residents have equal civil rights, and all male native-born and naturalized residents have equal political rights, subject only to reasonable qualifications of general uniform application. And the one fundamental and indispensable condition of a republican form of government is that all its officers shall be either chosen by the free vote of a majority of citizens or be appointed by other officers who have been thus elected.

"Now, there never has been a time in which a majority of so-called republics have answered this description. With few exceptions republics have either been close oligarchies or military despotisms; in none of which have the great mass of even male adult natives had equal civil rights or any participation in the free election of their governors. Sparta and Athens are examples of the earliest historic republics. Both were oligarchies in which only one man out of ten or twenty had the slightest share in government.

"At the present time there are twenty nominal republics in the world outside of Africa and the tiny mountain district of San Marino. These are France, Switzerland, the United States of America, Hayti, San Domingo, Mexico, Guatemala, Honduras, Nicaragua, Costa Rica, Colombia, Venezuela, Ecuador, Brazil, Peru, Bolivia, Chili, Argentina, Paraguay and Uruguay. Of these only Switzerland and the United States are real republics within any reasonable definition of that word. France is half republic and half military despotism. All the remaining seventeen are either absolute military despotisms or mere oligarchies, in which a small minority of the people monopolize all the powers of government, while the great mass are little, if any, better than slaves. The forms of republican government are undoubtedly maintained in nearly all of them to the same extent as they were maintained in Rome under Tiberius, or in France under the Prince President, Louis Napoleon. Legislatures meet and discuss at great length propositions of law, submitted to them by a dictator, at the end of which they vote in the

affirmative or fly for their lives. In Chili, Argentina and possibly one or two more of the republics there is a larger freedom of discussion and a greater absence of military dictatorship than in the others. But in Chili all the land worth having is owned by a few families, and a vast majority of the people are bound to these families in a mild but effectual slavery. In a large majority of these republics there is not, and there never has been, any government except such as was imposed by military force after a successful revolution, confirmed by the forms of a popular election, at which anybody was permitted to vote freely, provided he voted for the ruling dictator. Even subjects of the German and Austrian emperors have far more liberty and far more real voice in the government of their country than have the 'free and independent' citizens of any republic on the continent of America except our own. The subjects of the monarchies of Sweden, Norway, Denmark, Holland and Belgium have vastly more.

"It will thus be seen that there is no substantial foundation for the current opinion that the mere name of 'republic' is sufficient to entitle a government to the sympathy of any free and self-governing people."

HENRY WALLACE, of Iowa, recently read an interesting paper before the Kansas state board of agriculture on "Rotation of Crops." Although speaking to Kansas farmers, who are beginning to realize that there can be worn out the principles of crop rotation, he laid down one of general interest and application. He said, in part:

"The grain-growing habit once formed is likely to be continued until the clay streaks appear in the hillsides, until the soil begins to puddle in the wet time and bake in the dry time, until rust and smut, the chinch-bug and the grasshopper, drought and flood, have done their work, and the farmer begins to conclude that the seasons have changed, that something is wrong with the times, or perhaps with the administration.

"When the good people whom this society represents first came to Kansas they found that the Lord of the harvests had been there before them, and at work fitting Kansas for the habitation of some of the brightest, brainiest, most enterprising and least understood farmers on the face of the earth. They said, 'This is the garden spot of the West, with a soil of inexhaustible fertility that will stand more wet and more drought than any land under the sun,' and then, forgetting the Creator's work on their behalf, they began to waste and scatter the accumulated fertility of all these years by growing grain crops in succession and calling it rotation. The more they plowed the more rapidly the partially decomposed vegetable matter which the Creator had been storing up for all these countless years disappeared. The land became mortar in a wet time and crusted and baked in a dry time. The very earth under their feet began to be sad, discouraged, and the furrows even now, when the soil-robber is not through with his work, begin to complain, until Providence again interferes by giving him a crop of weeds. He is fast turning the keys on the fertility of Kansas lands. This explains your worn-out land. In point of fact, your worn-out lands are not worn out; they are only tired. What rotation is suggested for Kansas I am not here to say. She must work that out for herself. No rotation would be rational alike for eastern, middle and western Kansas. I will venture only to point out some general features that every rational rotation must have.

"First—It must maintain in the soil an abundant supply of partially decomposed vegetable matter by means of roots of grasses and grains. This is a point which has been very generally overlooked even by advanced thinkers. They have dwelt on the necessity of preventing waste of the three essential elements—potash, phosphoric acid and nitrogen. The gospel of humus is about as important as the gospel of grass.

"Second—A rational rotation must draw on free nitrogen of the atmosphere for a supply of nitrogen to the crops. Very few known plants are able to avail themselves of this atmospheric nitrogen except the legumes, and therefore a legume must have a place in every rational rotation. The legumes of the greatest agricultural value are the clovers, alfalfa, soy-beans and peas.

"Third—A rational rotation must provide in its grains and forage as nearly as possible a balanced ration for all kinds of farm stock. In the West special attention should be given to the supply of flesh-forming foods; that is, foods containing nitrogen in digestible form.

"Fourth—A rational rotation must provide for the destruction of weeds, and to this end must have what the English call 'hoed crops' and 'cover crops,' or what we call 'plowed crops,' and 'smothered crops.' A weed smothered is as effectually killed as though it were pulled up by the roots and hung on a barb-wire fence.

"Fifth—A rational rotation must reduce the amount of labor to the minimum. The labor problem is becoming more complicated every year. In times of prosperity the wages paid by manufacturing industries are too high for farm conditions, in times of industrial dullness there is an abundance of labor, but nine tenths of it is worthless on the farm. Farming now involves skilled labor and not main strength and awkwardness.

"Sixth—A rotation must provide for the distribution of labor through the entire year. No business can ever expect to attain even a reasonable degree of prosperity that does not provide moderate work twelve months in the year, and a crop rotation must consist of such a variety that it distributes the work through the year and provides profitable labor for the winter as well as the summer.

"Seventh—A rational crop rotation must enable the farmer to rid his farm of all the insects and other pests, which will, if unchecked, reduce his crops to a point where no profit results."

MARCH 12, 1898, Mr. J. E. Blackburn, dairy and food commissioner, filed a suit in the Supreme Court of Ohio involving the main questions in regard to making and selling colored oleomargarine in Ohio. The case is No. 6000, "State of Ohio versus Capital City Dairy Company," and was an action in quo warranto to oust the defendant as a corporation, asking the court to forfeit its charter and appoint a receiver to wind up its business.

April 10, 1900, the Supreme Court of Ohio handed down a decision ousting the Capital City Dairy Company from its franchise to do business in Ohio. The company was charged with a violation of the oleomargarine law by selling that product colored with methyl-orange, butter-yellow, aniline dye, etc., in imitation of butter; selling imitation butter in packages from which the label required by law was omitted; refusing to furnish a food inspector samples for analysis on demand, and with "wanton, persistent and flagrant violations of the provisions of the various food statutes."

Mr. Blackburn, commenting on the effect of the decision, said:

"This decision affects and disposes of the only two oleomargarine-factories in Ohio; namely, the Capital City Dairy Company, of Columbus, and the Union Dairy Company, of Cleveland. I wish to add that I have pursued this course confident of ultimate success, although a few persons who pose as leaders of the dairy interests were without confidence in the measure. Because I have been so confident, maintaining all the time that this was the only proper course to pursue to obtain all for which the farmers and dairymen were contending, my attitude on this matter has been questioned, and my diligence in the enforcement of the laws regulating the manufacture and sale of oleomargarine doubted."

By the laws of Ohio the manufacture and sale of oleomargarine is permitted if free from coloring matter or other ingredient to cause it to look like butter, and made in such form and sold in such manner as will advise the consumer of its real character.

Some oleomargarine manufacturers have been deliberately and flagrantly violating the law. They have abandoned even the pretense of obeying state laws, and bribe retail dealers with large profits to violate the laws and defraud their customers. To enable the retailers to deceive consumers they skilfully prepare their product in special forms, even down to "mixed, catch or country rolls," to resemble country butter as it comes to the store from the farmer.

The "Grocery World," Philadelphia, says: "The national live-stock exchange, made up for the most part of oleo makers and dealers, is asking Congress to turn down the bill taxing oleo ten cents a pound. The national live-stock exchange deserves not the slightest consideration from anybody, least of all of Congress or of legislatures. Its members have been more active in violating the laws of both than the worst criminal who ever served time. They have broken laws in every possible way—openly, with brazen effrontery; secretly, through bribery

of unscrupulous authorities. They have even poisoned the fountain of laws itself.

"There is no objection to oleo per se. It is perfectly healthful—fully as healthful as butter, frequently more healthful. The crying shame of the present century is that it is sold with a lie. For every man who sells it as oleo there are a hundred—yes, a thousand—who sell it as butter.

"The 'Grocery World' has always had a friendly feeling for oleo. We believe it to be vastly superior to the 'grade of butter within the reach of many poor people. We are just on the verge of concluding, nevertheless, that to stop the gross and glaring frauds that center about oleo its manufacture, even under innocent and honest circumstances, should be prohibited absolutely."

In an argument for the Grout bill, now pending in Congress, Secretary Knight, of the National Dairy Union, says: "The legislatures of thirty-two leading states have declared traffic in oleomargarine colored to resemble butter to be a menace to the individual rights and welfare of their people. Thirty-two legislatures have thoroughly investigated the matter, and in both branches came to the same conclusion. Our charge of fraudulent simulation has been sustained by the representatives of four fifths of the people of this country, and the high courts have invariably pronounced their grounds well taken and their reasoning sound. It is not a case of Congress oppressively taxing the people, or wrongfully employing its taxing power; it is a case where the people of practically every state arise and appeal to Congress for aid in accomplishing something which they have sought but failed to do with state laws specially enacted."

UNDER date of April 14th "Bradstreet's" says: "Statistics compiled in the Treasury Department and made public this week enable us to supplement the figures as to circulation given last week with some comparisons covering a decade. The date chosen is that of the last monthly statement; namely, April 1st. It is shown by the figures that, as compared with the year 1890, there was an increase on April 1st this year of not far from \$600,000,000. The interesting fact is revealed by the statistics that the year 1896 represented the lowest level of circulation since the year 1890. The amount of gold coin and gold certificates in circulation is greater by over \$277,000,000 than it was in 1890, and it is no surprise to learn that, as in the case of the circulation as a whole, the portion of it represented by gold and gold certificates was at its lowest ebb for the decade in 1896. The comparisons suggested by these figures are particularly gratifying, looking backward as they do from a date when the amount per capita, as well as the total volume of circulation, stood at the highest mark reached in the history of the country.

"In response to a resolution adopted by the House of Representatives at the beginning of the month, Secretary Gage has transmitted estimates of the probable receipts and expenditures of the government for the current fiscal year and for that immediately following. These estimates are interesting from several points of view. As was to be expected, in view of the statistics for three quarters of the fiscal year commented upon in our last issue, the Secretary looks for a considerable surplus at the end of the Treasury year, though one slightly under the average for the period that has already elapsed. He figures out a total of receipts amounting to \$560,000,000, and of expenditures amounting to \$490,000,000, leaving a surplus of \$70,000,000 in round numbers on June 30th. It may be recalled that for the nine months ending with March the excess of receipts over expenditures amounted to \$54,300,000, and that not far from a third of that amount was rolled up as the result of the operations for March. It would occasion no surprise to find at the close of the fiscal year that the Secretary's conservative estimate had been exceeded. The Secretary looks for a gradual increase of the surplus in the near future. For the next fiscal year, ending on June 30, 1901, he estimates a surplus of \$82,000,000 on the basis of \$577,000,000 of receipts and \$495,000,000 of expenditures."

The estimated surplus revenue for the fiscal year ending June 30, 1900, is \$75,000,000. The internal revenue for war-stamp taxes for the same year will amount to about \$45,000,000. An exceptional opportunity is, therefore, now before Congress for making a necessary reduction in the surplus revenues by abolishing the whole series of stamp taxes by one act.





## ABOUT RURAL AFFAIRS

**Pan-American** A great exposition is the great gruidstone on which people sharpen their wits and polish their manners. As an educational means, in fact, such exposition is far more than a mere mammoth county or state fair, with its many fakes and fakirs and its few industrial and agricultural exhibits. Americans are a nation of born travelers. They come in contact with the world; they see and learn, and therefore they are self-reliant and at home in a palace as well as in a shanty. But a real world's fair calls out thousands of reserves; namely, habitual stay-at-homes. It throws rays of light in the remotest corners of the country which are as yet little affected by the general move and desire of travel. The great fair at Paris, of course—a wonderful thing, no doubt—can hardly be expected to do us American people much good in this respect. Only few of us, and these among the wealthy classes only, can avail ourselves of the opportunity, for France is far and the trip rather expensive. But if we will have patience for another year we shall have the chance to see an exposition nearer home and without crossing the Atlantic. An exposition which, though perhaps of less gigantic proportions, will show more industrial and other wonders to the square foot than that at Paris, and will be just as interesting, just as instructive, and I fear as much a demimonde fair (a half world's fair as well as a new world's fair) as the other.

\*\*\*

This great coming fair is the Pan-American at Buffalo, to be opened May 1, 1901. I know something about its inception and first organization. Within a mile of my home, and where this is written, is Cayuga island, a small island in the grand Niagara, of rare scenic beauty, close to the spot where the French explorer LaSalle built the Griffin, the first large vessel that ever plowed the waters of the Great Lakes, and within sight and hearing of the majestic cataract. The availability of a site which seemed to be created for the very purpose suggested the idea of holding an all-American fair at the close of the old or at the beginning of a new century. But to make a great fair requires more than an ideal site. The proverbial three things must be found; namely, money, more money, and a great deal of money. President McKinley seemed to take a great interest in this fair project. He was even induced to visit the spot and drive "the first stake." He gladly signed the bill appropriating a half million dollars of the nation's money for making a big government exhibit. The state of New York followed suit with another big appropriation, and other states imitated the example. But Buffalo people had to go down deep into their own pockets to get the ball rolling, and we could not find fault if they in return wanted the fair where it will do them the most local good; namely, in the heart of Buffalo. So we had to see the fair slip away from us; but though our village people, and especially myself, lost a great opportunity, we have taken our medicine like men. No doubt this fair has local advantages which no other fair has ever had. Forty million people live within twenty-four hours' ride on steam-cars from the fair-grounds. And millions of these would think the trip well repaid if they had nothing else for it than a visit to the great cataract and its scenic surroundings, the new steel arch bridges, these wonders of modern engineering skill, and to the power-house, where a fraction of one per cent of the waters rushing over the precipice develops electric power equal to one hundred thousand horse-power. This location within easy transmitting distance from the center of the power development must make this Pan-American fair the great electrical exposition of the age, and it will be a blaze of electrical light and glory from beginning to end, and worth seeing on this account alone.

\*\*\*

But the Pan-American promoters and the American people generally who have accepted this point of view seem to have fallen into a queer chronological error. They are bound to have the twentieth century begin with 1901. There has been much dispute about this, and heretofore I had myself accepted the American view. But a little figuring of my own convinces me of the error of that reckoning. The first year of our time begins with Christ's birth. This is equal to 0, for we reckon time by the

designation "before" and "after" Christ. Therefore, the year 1 after Christ began with the first of January, and ended with the last day of December of the same year (1), but it surely was already the second year of the Christian era. So the year 99 was the one hundredth year of the Christian era, and closed the last of December, 99, thus completing the first century. The second century began on January 1, 100, and the twentieth century on January 1, 1900.

\*\*\*

### Planting for Quick Effects

I expect to be on the fair-grounds more or less every week from now on. One of the things that will interest us rural people especially during the building of the exposition is the planting which has to be done for quick effects. Large trees are being brought on and set into their new positions. Shrubbery and herbaceous perennials have to be placed where they will show off to best advantage next year. It is not like setting orchard-trees or ornamental growths around a dwelling, or making a new lawn, as we are used to doing these things. For in our own cases, if we do not secure the best results in one year's time we simply wait another, or a third or fourth year, as the case may be. But here the results must be seen in 1901. Undoubtedly there is much that we can learn for home application, both in the handling of the different growths and in the selection of materials.

\*\*\*

### Tanning Belgian-hare Skins

A reader, Mrs. A. L., of Dunlap, Illinois, asks me how to tan Belgian-hare skins. I have killed a good many of these animals, and often thought it a shame to throw their skins away. But that is quite generally done. As I stated in my last, the usual way of skinning hares is by ripping the skin open in the back and pulling half over the head, and the other half the other way, thus, of course, spoiling the skin for tanning. I do not know to what particular use the skins could be put, but they seem to be very good fur and ought to come handy for something. I am not an expert tanner and can give no advice. Directions, however, have frequently been given in almost any agricultural paper. I find, for instance, the following in Short Cuts, "Practical Farmer:" "To tan hides with the hair on for soles, mats or rugs, wash the skin and remove all fleshy matter by scraping. Then wash hair side with warm water and soap, and rinse. Take one quarter of a pound each of salt and pulverized alum, one half ounce of borax, dissolve in hot water; add enough rye-meal to make a thick paste, and spread on flesh side. Then fold lengthwise, flesh side in. Let remain two weeks in an airy and shady place, then unfold, shake well, and wash flesh side in water and scrape with a dull scraper. Pull and stretch and work until dry."

\*\*\*

### New Land For Gardening

A reader in New Jersey (A. R., of Holden) having bought a piece of cleaned woodland wishes to get it in shape for growing vegetables. It has a loose, dark surface soil six to twelve inches deep; then a layer of stiff white clay about four to six inches deep; then a layer of clayey white sand eighteen to twenty-four inches deep, and under that a layer of yellow sand. Ground water stands at a depth of from five to six feet. I could tell better what to do with this if I could view the location. The first thing to do, of course, is to secure perfect drainage; if necessary, by tiling. You do not want a spot for vegetable-growing that has surface water. Possibly the object may be secured by subsoiling, with a view of breaking the shallow layer of stiff clay under the surface soil and thus giving the surface water a chance of escaping down into the ground water, which is deep enough for all practical purposes. Next plow the field and plant a rather coarse-growing hold crop, such as corn, potatoes, etc., or sow it to grain and clover. I would prefer the hold crop, which is more apt to bring the land under full control. Apply manure as liberally as convenient, and after a year or two plow again and plant your vegetables. The coarser growers, like tomatoes, sweet-corn, early potatoes, etc., can always be planted on the rougher portions of the field, while the best and loosest portions are to be reserved for the small stuff. T. GREINER.

## SALIENT FARM NOTES

**Overeating** "My stomach seems to be badly out of order," said a strong young farmer to me one day last spring. "I feel dull, sleepy and tired every forenoon until about ten o'clock, and again after dinner until about four. I tried some bitters, and the doctor gave me some medicine, but neither seems to do me any good. I eat rather heartily—have to in order to last until the next meal—but still I have a half-hungry, flabby feeling in my stomach most of the time. I fear there is something seriously wrong with my digestive organs." "I rather think there is," I replied. "You are afflicted with that 'tired' feeling, and that is caused by overeating. Had the same complaint myself until I learned to treat my stomach right. I used to fill myself up to the throat with heavy food half masticated, and wash it down with two or three cups of strong coffee, then wonder why I felt so dull and tired for two or three hours afterward. A sensible physician informed me that there was nothing the matter with me except that I lacked a little common sense. You're afflicted about as I was."

\*\*\*

This physician said that American farmers should be the healthiest people in the world, and would be if they lived properly. He advised me to eat a light breakfast, drinking only one cup of coffee, have a light lunch sent to me about half-past nine A. M., eat moderately at dinner, have another lunch at half-past three, and finish the day with a light supper. He said, "Don't eat enough at any time to fully satisfy your appetite; that is, don't eat until you feel full. Take plenty of time to masticate all your food thoroughly, drink moderately of coffee or tea made about half as strong as they usually are, and don't jump up from the table and rush into hard work. Rest a few minutes, fifteen or twenty, after meals. Keep in mind the fact that it is a comparatively easy matter to keep your body in good order by the observance of a few simple, common-sense rules. Eat lighter meals and more of them; begin work easily and steadily and increase your speed (if necessary) after you warm up. Quit work before you are exhausted. Health is the most valuable thing one can possess. It is worth any care and the sacrifice of any prospective or imaginary pleasure."

\*\*\*

The old doctor said further that as we live only one life we should live it so as to get the most out of it. A healthy person can, if he will, accomplish a vast amount of good; he can help himself and many others; while a sickly person is not able to help himself even much of the time. Since I adopted his advice to eat less at a meal and oftener I have not been afflicted with that "tired" feeling, nor with "spring fever." When a person is working in the open air day after day during the winter he can eat lots of meat, fats and other strong food, and they are what he needs. But when the warmer days of spring come on he should adopt a lighter diet and eat less. If he does this he will have no "spring fever." The young farmer mentioned above adopted my plan and in less than a month afterward told me that he felt like a new man. All that heaviness and distress at the stomach was gone, and, as he said, "I feel first-rate all day." It was not "bitters" or "spring medicine" he needed, but a more sensible dietary.

\*\*\*

### Care of Farm Implements

At a farmers' institute held in an adjoining county not long ago a very successful farmer spoke on the care of farm implements. In the course of his talk he said, "The price of lumber has gone soaring until it is almost out of reach. Iron and steel, which were rapidly taking the place of wood in the manufacture of implements, has gone higher even than lumber. As a consequence the price of all kinds of farming machinery is much increased. The question now confronting us is, Are we able to pay these prices? Present prices of farm products do not justify me in saying that we are. In my opinion the unprecedented demand for iron and steel which has prevailed the past two or three years is the principal cause of the great rise in prices, though combinations of manufacturers have had something to do with it. That present prices cannot long be maintained is plain to the close observer. Iron and steel must come down, because consumers cannot afford to pay present prices. Until prices do come down it is the plain duty of the farmer to buy as little as possible. We can repair our old implements, use them more carefully, take the best of care of them, and I think we

will be surprised at the amount of work we can do with them, as well as at their lasting qualities."

\*\*\*

We do not care for our implements as we should. A farmer should be ashamed to have a rusty plow, cultivator, spade or hoe on his place. All that is needed to keep them bright is a little grease applied when we cease using them, and shelter from sun and rain. To allow them to become rusty and then rub the rust off with sand-paper is to wear away more steel than would be worn away in a whole season's use. We should not attempt to file or grind a sharp edge on a tool if the edge is thick. Take it to a good blacksmith and have him draw it out. If he understands his business he can put a far better edge on it than we can with file or grindstone, and the tool will do far better work and last much longer. I have my spades and hoes drawn out, as well as plow-shares.

\*\*\*

In the use of tools skill is far superior to strength. A small, active man can accomplish much more with a light, sharp, bright implement than a large, strong man can with a big, clumsy tool. A team of light horses can turn as much land with a thin-shared, sharp plow as a big, strong team can with a thick, dull one. One saves time and labor by keeping his plowshares well drawn out and sharp. If there are no stones or hard roots in the soil the shares should be kept drawn out thin and be touched up with a file twice a day. It is the wisest sort of economy to keep tools sharp and bright. It is economy, also, to keep handles, beams and all other parts of like nature painted with oil and red lead. This paint costs but little and it is a great protector of both wood and iron. It prevents wood from checking and splitting and rotting where joined together, at bolt-holes, etc., and iron from rusting and becoming "rotten" at the thinner parts and about bolts. In the hands of a careful man an ordinary tool will do first-class work for many years, because he will take the best of care of it; but in the hands of the careless "average" farmer its years of usefulness are generally few, because he allows it to rust and rot in the field or fence-corner. If ever there was a time when tools of all kinds should have the best of care that time is now. The price is high; they cost more than we can afford to pay; but we shall not be obliged to buy many if we take first-class care of those we have, and a limited demand invariably brings down the price.

\*\*\*

### Pruning Apple-trees

C. B. S. says his apple-trees are "so full of branches, most of them growing straight up out of the main branches, that a cat could scarcely get into the tree." He wishes to know what he shall do with them—if it is now too late to cut them out. These upright shoots are termed "water-sprouts," and when a tree stands in rich soil it will sometimes send out hundreds of them. My Ben Davis and Jonathan trees had from twenty-five to fifty or more in them last fall. I was so busy during the summer that I did not have time to remove them, but it was done in the fall. C. B. S. should remove them at once, clipping them off close to the limbs from which they start. If left where they are they will ruin the tree. Next July or August he should go through the orchard and with a small hand-pruner or a sharp one-inch chisel cut them out while they are green and soft. The job is easily done then, and one can trim out a large number of trees in a day. I have a pair of pruning-shears that are opened by a spring, and I can snip out these sprouts rapidly with them. They can be obtained at any hardware-store.

\*\*\*

### Changing From Dry Food to Grass

Where cows are turned on grass in the spring their dry food should be continued the same as before. Young grass will increase the flow of milk, but it does not keep up the condition of the animal. I have seen cows come from the early pastures and eat old, coarse hay and weather-beaten straw as though they were ravenously hungry. If their grain and hay feed is continued about a month the animals will gain in flesh, while the milk will retain its high quality. The dry food also tends to counteract the laxative effects of young grass and to keep the digestive organs in better condition. Changing from dry food to an exclusive diet of young grass annually causes much loss among cattle. The change should be accomplished gradually and no evil effects will follow. We should be careful to remember that cattle should have all the salt they want at this time.

FRED GRUNDY.



## OUR FARM

### FARM THEORY AND PRACTICE

**P**OTATOES FOR PROFIT.—The man that has the right kind of soil and a fair market can make money growing potatoes. The crop is profitable because it requires more care and good judgment in its raising than many give it, thus keeping production within bounds. This is not wholly true for the northwestern states, but it is for the central and eastern states. Corn and wheat can be grown more easily and carelessly, for that matter, than can potatoes, and hence there is more money to the acre in the potatoes, net cash returns for crops usually being greatest in the case of those requiring the best culture and attention. Just so long as many are careless about the seed used and the culture given that long will the careful grower find the potato crop profitable. He has an advantage that makes the difference between profit and loss.

\*\*\*

**THE SOIL FOR POTATOES.**—It must be reasonably loose. The close, tight soil cannot produce a good crop. If the ground is naturally compact rotting sods must be incorporated with it. Wet land must be underdrained. Stable manure is all right—is a big help especially to cold, compact soils—but it should go on the ground the year previous to planting, and be well rotted. Otherwise the scab may thrive and injure the potatoes for market. The sod should be left well on edge in the plowing, keeping some of it near the surface. All these things help to make a soil loose, while the decayed vegetation adds to the power of the soil to hold moisture. Potatoes are a water crop.

\*\*\*

**SELECTING SEED.**—Half the battle in securing a good yield of potatoes is strong plants when they first appear above ground. Unless the sprouts show thrifty then the chances are against the grower. Such plants come only from seed full of vitality. That seed may be small, or it may be from large tubers, but vitality it must have. In all forms of life it is vitality that counts. A small potato—that classed among the "seconds"—may be all right. If it grew on a strong vine, being a second setting that did not have time to grow as large as the tubers set first by the plant, it comes of good stock and will probably keep up the family record; but if it came from a spindling vine, and is small because the vine lacked the vitality to produce the best tubers, it is not good seed. The grower can know how vital his stock of potatoes is, and should be quick to discard it when many hills show weak vines. Just because the spindling hills furnish such a large share of the "seconds" of a crop my individual preference is for large tubers for seed—not overgrown ones, as some of their eyes near the stem-end may be "dead" eyes and become responsible for missing hills, but medium-sized tubers that can be cut to two eyes without making the seed-pieces too large and expensive. But the "seconds" may produce as good a crop; only the grower must know that they have vitality. The first sprouts are best. Cold storage is best when keeping for June planting; for early planting pits or dark cellars are all right.

\*\*\*

**LIGHT AFFECTS THE SPROUTS.**—We know that the potato that starts its sprouts in the light gives the strongest vines. Such sprouts are strong and vigorous. The grower that plants late can expose the seed to the light for a week or two, starting the buds heavy and vigorous, but the one that plants early cannot do this. The next best thing, and about as good, is to cover very lightly. The deep planting is secured by having the furrows deep, no matter whether made with a planter or a plow for hand-planting, but the seed in these deep furrows should be barely covered. This applies more especially to soils that are not very porous. The seed is near light and air, puts forth a strong bud, and then is covered more deeply as the plant grows, by filling in the furrows with harrow or weeder. Two such cultivations, given as the plants appear through the soil, will fill the furrows, leaving the ground about the plant loose, fresh and clean of weeds, while the sprouts have had the advantage of sunlight throughout their time of growth. They have not pushed a rapid growth of slender white stem to reach the sunlight, but have come up well thickened from the very potato, just as any plant grows when fully exposed to sunlight. Plant potatoes deep, because the roots should be down with the

moisture; but in soils at all close do not exclude all light by a covering several inches deep if the best plants are wanted. The ridging of the row, to be followed by the drag later, gives a clean row, to be sure, but so does the shallow covering in a deep furrow, and the latter lets in the light that adds to vigor of stalk at its base, where it leaves the seed-piece.

\*\*\*

**LATER CARE OF THE CROP.**—If the soil is right and the plants strong one can then work with expectation of profit. A deep cultivation early in their growth gives the plants loose soil for making their sets. Then all that can be done in the way of tillage is to keep the moisture in the ground and the weeds out. That means plenty of shallow tillage. It is never necessary to permit the bugs to injure the plants to any serious extent. The fight must be made early. If arsenites are properly applied before the little larvae scatter over the top death is sure. It is folly to spend good money on seed and tillage only to let potato-bugs cripple the plants. Get the arsenite into the buds of the plants while the "young bugs" are there, feeding on the tenderest leaves. Later they scatter over the branches and are more difficult to kill. Some go into the ground, reappear as beetles, and raise another brood. If this is prevented—and it can be—there need be no loss on this score. The blights are more difficult to control—too difficult in moist weather.

DAVID.

### A HOME-MADE LAND-ROLLER

A good farmer from Virginia—I know he is a good one because he is on the watch for anything which will enable him to do better work on his farm—writes me:

"Will you do me the kindness to give me the directions for making the land-roller you spoke of in a recent article? I have needed one for some time, and being somewhat of a 'fixer' myself I believe I can make one that will answer the purpose without incurring so much expense, and that is a great help to a farmer these days."

It may be some other farmer would like to know what I told my Virginia friend, and I am here describing my roller as well as I can, with the hope in view that it may be of use to such as may be inclined like myself to tinker in the barn on stormy days.

In the first place, you need four old mowing-machine wheels. If you haven't them

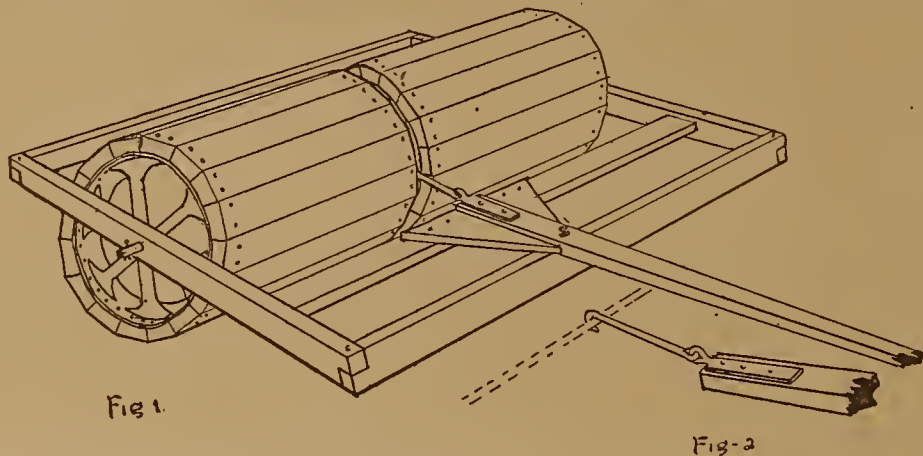

perhaps you can find them at a neighbor's; if not, no doubt they may be had cheap at a scrap-yard in the city. I got mine at such a place. Be sure they are whole. Cut a hard-wood log eight feet long, and have it sawed into planks six inches wide and two inches thick. If you think this too heavy have the thickness one and one half inches. I used for this a hard-maple log. Saw these planks in two at the middle, and these will be the covering for your wheels. Get two or three three-eighths steel drill-bits. With a three-eighths bit bore two holes in each end of each plank, and drill corresponding holes through the rims of the wheels. Chamfer the edges of the plank so that they will come up close together before boring. With three-eighths soft iron rivets long enough to reach through the plank and the rim of the wheels fasten the planks firmly to the inside of the rim.

Build a frame large enough to go over the two sets of wheels when placed end to end, leaving a little room for play. For this use hard-wood scantling three and one half inches square. Mortise together at the corners, and also bolt through the corners. Before putting the frame together mortise a crosspiece of the same sized scantling about eight inches from the front piece of the frame and running parallel to it. See Fig. 1.

Buy a steel rod long enough to reach clear through the roller and not quite as large as the holes in the wheels. The wheels are to turn on this rod, the rod remaining rigid. Just at the outside of the wheels drill holes

for pins, to hold the wheels on. In locating these holes do not crowd the two pieces of the roller tight together. Leave at least an inch of space between the two. Let the rod be long enough to reach out under the frame of the roller, and when complete secure in place with two old bearings of a mowing-machine.

Put the rod through one of the rollers and put in the lynch-pin. Now? I have found that without some support in the middle the axle is apt to sag back when at work if you strike a stone or some other obstacle. To prevent this I had a blacksmith make a device of iron one half inch by one inch, like a long hook, open at one end, as in Fig. 2, and long enough to reach nearly out to the first crosspiece of the frame. Through a hole in the outer end of this I had a link of iron, say two inches long, put. The other end of this link passes through a plate of iron three inches wide and long enough to bolt to the frame. The same bolt which holds the tongue to the frame passes through this plate. Thus, when the roller strikes a stone the rod yields, but can go only so far, when the hook catches it and holds it solid. Put the hook over the rod and slip on the other roller. Put in the lynch-pin, and bolt on the bearings. Bolt an old mowing-machine tongue to the middle of the frame, letting it reach both frame-pieces and stiffening it by bolting on each side a strip of hard wood wedge-shaped, two feet long and six inches at the widest end.

If you wish to ride, make a cover of boards to fit over the roller, resting on the top of the frame, and held to it by dowels, also by a hook at each end. Bolt an old mowing-machine seat to the top at the back side, to relieve the horses' necks, letting the bolts pass not only through the boards of the cover, but through a piece of two-by-four placed up under the cover.

My roller cost me in the neighborhood of \$4.50, but I think it would cost more now, on account of the increase in the price of material. This is not counting anything for my work.

E. L. VINCENT.

### OVER THE BACK FENCE

"And so," said Mrs. A. to Mrs. B., as she crossed her arms on the back fence, "you don't buy your milk of Mr. X. any more? What is the reason? Short measure, or what?"

"No, 'twasn't short measure," answered Mrs. B., "but 'twas something much worse.

His milk was filthy. I went to pour some into the baby's bottle the other morning and there actually was half an inch of sediment at the bottom of the pitcher. I was thoroughly disgusted, and promised the family I never would buy another quart of milk from X. as long as he or I lived. But John said there might be some mistake—you know John is always making allowances for everything and everybody—so he persuaded me to hang the pail out just once more, which I did, the result being that the milk was as dirty and bad as before. Well, I threw it into the slop-bucket and proceeded to tell John that either he would order Mr. Z.'s milk-wagon to stop here mornings or I would. Seeing I was very much in earnest, and realizing for once that I was right, he did as I suggested; and oh, Mrs. A., for a whole week now we have been getting the loveliest, cleanest milk you ever saw! Sweet as honey, with thick, delicious cream on it. Slightly different from Mr. X.'s, I assure you."

"Yes, but what makes it so much different?" said Mrs. A., rubbing her nose. "Mr. Z. has no better facilities than Mr. X?"

"Better fiddlesticks!" broke in Mrs. B. "No, I don't know as he has; but I do know one thing, and that is he takes much better care of his cows and cow-stable than Mr. X., and right there, let me tell you, is where all the secret lies. You see, John, being of that nature that he can't bear to give offense to any living creature without apologizing for it afterward, naturally wanted to say a few conciliatory words to

Mr. X., so he wouldn't take our refusal to buy any more milk of him too much to heart. So he and I took a stroll over to his place late one afternoon just as he was milking. My! I wish you could have been there and seen his stable and his cows! They were in an awful condition, and it seems to me that any conscientious milkman would have been ashamed of them. But X. didn't seem to be. The stable looked as though it hadn't been cleaned out in half a year at least, and the poor, bony, dirty, sorrowful-eyed cows were kicking and splashing about in the filth in a way that was as startling as it was disgusting. Mr. X. was milking into a pail that I wouldn't have cleaned up for fifty cents. He acted so careless and negligent that it almost turned my stomach. We watched his proceedings quite as long as we cared to, then John looked at me and I looked at John, and John said words to Mr. X. that weren't half so conciliatory as they were first intended to be. But I think they set X. to thinking.

"Suppose we walk over to Mr. Z.'s place of business and see his methods," said I, after we were safe on the sidewalk again.

"All right, suppose we do," said John; and so we walked on a little further down the street. When we arrived at Mr. Z.'s stables we beheld some nice floors bountifully sprinkled with straw, in which the sleek-coated cows were contentedly standing, cleanliness and contentment plainly bespoken in the lazy chewing of their 'cuds' and in their half-closed, sleepy eyes. They looked so sweet and clean I just wanted to go up and give each one a good big hug. Mr. Z. in clean overalls, and a pail that looked as though it had come direct from the tin-shop, was milking. He held the pail well up from the ground in a very businesslike manner, so that no dirt could get inside, and all in all looked such an exact opposite to Mr. X. that I couldn't forbear whispering to John that it would be ever so nice to buy a whole lot of milk-tickets right on the spot, although we had a few unused ones yet on hand. John acted upon my suggestion, and bought two dollars' worth then and there. So you see," concluded Mrs. B., "that in order to give his customers first-class milk a milkman must give his cows and their habitations first-class care."

SOCRATES.

### POTATO CULTURE IN OLD VIRGINIA

In potato culture here the essential point is to get the Holton Early Rose, or some other equally reliable variety, in just as early as possible. My plan is to cut the pieces so that there will be one good strong eye on each, and then bed them in moist, sifted coal ashes, in broad, shallow trays, and place these where the heat and an occasional watering will soon set them growing. They are soon made ready in this way for planting in the garden. A good formula for the fertilizer is superphosphate, forty-eight pounds, nitrate of soda, thirty-two pounds, and muriate of potash, thirty pounds. Apply at the rate of eleven hundred pounds to the acre. After opening the furrows with a single-shovel plow I put in half the fertilizer, using a large handful to a yard scattered in the bottom of the furrow. I then cover this with an inch of soil and place the potato-eyes one foot apart in the row. I then rake in enough earth to cover them with another inch of earth, and scatter an equal portion of the fertilizer thereon, and then level off the surface in the garden with the rake and in the field by running a double-shovel between the rows. For the amount of each of the above-named fertilizer for an acre it is only necessary to add a cipher, making the forty-eight four hundred and eighty, etc., or eleven hundred pounds in all. If one has a good clover sod to turn under he can, by using a first-class fertilizer like the foregoing one, succeed in raising a paying crop.

J. W., JR.

### CUTWORMS

Last spring I broke up and planted to corn a piece of land that had never grown anything but weeds. In due time the seed sprouted, but cutworms were so numerous that the sowing was a waste of seed and time. Not a tenth part of the plants were left.

This opened the way to test various methods of killing the pest, but none were so useful as a dry mixture of equal parts of bran and middlings, fifty pounds to one of Paris green. A seed-drill was used to sow this mixture on the surface, both around the outside of the field and close to the rows. This dry mixture was most satisfactory, since it could be much more readily, quickly and evenly applied than the others, and because a larger number of worms were found dead where it was placed.

M. G. KAINS.





## NOTES FROM GARDEN AND FIELD

length. This process seems to preserve all the vitality that is in the tubers, and to make the latter respond promptly with vigorous growth when put into the ground.

\* \* \*

As I said before, the best yield can only be produced from strong and healthy plants. There seems to be also a tendency to continue this quality in the race or strain. Years ago Professor E. S. Goff, now of the Wisconsin Experiment Station, selected tubers from most prolific hills and also from least prolific hills, and secured better yields by planting the former than he did from the latter. Plant even the small potatoes out of the best hill in the field and they will be likely to give a better yield than the large potatoes out of the poorest hill. Besides all these influences there is the effect of the way in which the seed-tuber is cut. Many growers advocate and practise planting single eyes or two-eye pieces. My experience is that the larger the seed-piece, under average conditions, the larger the resulting plant and the greater the yield. Single-eye pieces cut from large potatoes are larger than those cut from small potatoes, and therefore I consider them better seed. But a medium-sized or small potato planted whole is in my estimation as good for seed as a piece equal in weight to the other of a large potato, always assuming, of course, that both pieces are in equally good state of preservation. On the whole, I believe that a variety or strain of potatoes is in greater danger of "running out" by continued close cutting for seed, especially if small potatoes are used for seed, than by the practice of planting small potatoes, so long as the latter are well preserved and not cut to any great extent. My own choice for seed consists of medium-sized tubers planted whole or in halves, or larger ones cut in quarters. And when we thus grow potatoes, preserving all the original vitality of a potato variety, I can see no earthly reason why we should change seed, calling on Tom, Dick and Harry for a supply of seed such as we have just as good or better ourselves, or why we should forever hunt for new varieties, that coming fresh from true seed are supposed to contain all of a new seedling's original vitality and freshness. But any variety will be sure to "run out" if subjected for a series of years to the enervating effects of the use of very small seed-pieces or of badly kept seed-tubers or to the yearly attacks of bugs and blights. I think these remarks will fully answer my correspondent's questions.

\* \* \*

**GROWING TOMATOES FOR CANNING-FAC- TORY.**—An Indiana subscriber asks me whether it would pay him to raise tomatoes and haul them nine miles to the factory at seventeen and one half cents a bushel. I know that the farmers around here were glad enough some years ago to raise tomatoes at about twenty cents a bushel when they could deliver them at the factory within a mile or so; and they were sorry to see the factory quit business. But I doubt whether they would have been willing to grow the tomatoes at seventeen and one half cents a bushel and haul the crop very many miles. This price is equivalent to a little less probably than six dollars a ton. This price has been paid quite commonly to growers in New Jersey, Maryland, etc., by the factories there. I do not know how far some of the farmers had to haul the tomatoes. If a short distance only, tomatoes probably pay at this rate as well as a good many other crops, although the growers will not grow rich very fast at it. At the present time some factories propose to cut the price to five dollars a ton, and of course there is trouble, and I do not know whether many farmers will agree to raise the crop for the cut price or not. On the whole, it is a business question which each grower must decide for himself.

T. GREINER.

### INQUIRIES ANSWERED

BY T. GREINER

**Blue-husk Tomato.**—H. L. S., a reader in Big Stone county, Minn., asks where he could get some seed of the blue-husk tomato, which is similar to the common ground-cherry, only larger and different in color. I have never seen a blue-husk tomato, and call on our readers to tell us if they know of any such thing.

**Cedar Sawdust.**—E. L., Whatcom county, Wash., writes: "Please tell me as to the effect on farm-land of the application of cedar sawdust in considerable quantity."

**REPLY:**—If the sawdust is well rotted I would have no fear of applying it in considerable quantity upon land that is rather stiff and deficient in humus. It will make such land lighter, looser, warmer, and consequently be of benefit for general cropping. Of course, it should be well mixed with the soil. If the sawdust is fresh I would not use it except perhaps as a top-dressing and mulch.



## ORCHARD AND SMALL FRUITS

CONDUCTED BY SAMUEL B. GREEN

### THE STRAWBERRY

[CONTINUED FROM APRIL 15TH ISSUE]

**HOW TO CONTINUE BEDS IN BEARING.**—Some growers think it best to fruit their strawberry-beds but one season. Others think it best to fruit the bed at least two seasons, provided it is in good condition when the first crop is gathered. I have often had the second crop on a strawberry-bed better than the first, but generally it is not quite as good. The best plan to follow with an old strawberry-bed is about as follows:

**RENEWING STRAWBERRY-BEDS.**—There are several ways of renewing an old strawberry-bed, but perhaps the following plan is as good as any: As soon as may be after the crop is gathered the bed is closely mowed and all the weeds and strawberry-leaves burned. This burning must be done when the fire will run rapidly, for if it burns slowly it will kill the plants. A plow is then run on either side of the matted rows and all but about one foot in width of it turned under. The furrow thus made is filled with fine rotted manure and the cultivator set going. The plants remaining are then thinned out with a hoe, and special pains is taken to cut out all weeds and old or weak plants. This leaves the old bed clean and with plenty of manure close by, in which the old plants can make new roots. The plants soon send up new leaves, which are much healthier than they would be were the old foliage allowed to remain, and if we have an ordinary season an abundance of runners will be sent out, and by winter the old bed will look nearly as vigorous as a new one. I have also used very successfully a two-horse corn-cultivator to cut out the rows, and a disk-harrow with the two inside sections taken off is also excellent for this purpose.

This method of renewing the old bed has the merit of destroying all the diseased foliage and to some extent also injurious insects. It is very important that the renewed bed be kept healthy by frequent cultivation and the destruction of any insects that may appear, in order to have it do its best in fruiting the following season.

**SEXUALITY OF THE STRAWBERRY-BLOSSOM.**—We have two classes of varieties of the strawberry, distinguished by their blossom. One class has perfect flowers; that is, all its flowers have stamens and pistils (male and female organs). These can be planted alone, without any other variety near, and will produce fruit. This class may be called bi-sexual. The other class has pistils (female organs), but does not have stamens, or has very few of them. This class is called pistillate. It is found in practice that many varieties with pistillate blossoms produce more fruit than those with bi-sexual flowers, consequently it is often advantageous to raise as many of such kinds as possible and as few of the others, but it is necessary to have some of the bi-sexual kinds near the pistillate kinds or no fruit is produced. Just the proportion that should exist between the bi-sexual and the pistillate kinds is a disputed point, but it is probably about one to three or four, depending upon the weather at the time of blossoming. It is safe to say that when pistillate kinds are used every third row should be of some bi-sexual kind, selected so that it will be in flower at the same time as the pistillate variety. Some growers recommend that every third plant in the row be of some bi-sexual kind. The objection to this way in practice is that the pistillate kinds being often the strongest growers may soon crowd out the weaker variety; and then again when this plan is followed the plants when taken up are so hopelessly mixed as to be worthless for setting a new bed.

A bi-sexual or perfect-flowering variety differs from a pistillate variety chiefly in having between the petals and the pistils a ring of many stamens. This difference is plainly seen in flowers of the different kinds by any one who will take the pains to more than glance at them. It will be noticed that the bi-sexual variety has six petals and the pistillate five petals. This is not a constant variation between the two kinds, and is of no importance, but it is thus shown to call attention to the difference in the number of their petals in varieties, and it is not uncommon to find a strawberry-blossom with seven petals, although the normal number is five. Different flowers on the same plant even may vary in the number of their petals.

**PICKING AND MARKETING.**—If the berries are to be sold great care should be taken to have them carefully picked. Green ber-

ries are bad enough to have in a box, but if they are to be shipped overripe ones will cause much more trouble, for they are sure to decay before they reach their destination and to damage all the good fruit. On this account the beds should be picked clean every day in warm weather. The pickers will need careful watching, so as to be sure they do not put poor berries in the bottom of the boxes, and that they pick all the ripe berries, so none will be left to get overripe. It is always desirable to pick fruit that is to be shipped in the cool of the day, unless it should be wet.

Gift packages holding sixteen or twenty-four boxes are almost universally used in the South and the West. They cost about twenty cents a crate, including boxes and cover. They are always made so there is room to heap up the boxes and to allow of a circulation of air through the boxes. A box holding little more than a dry-measure quart when even full, and nearly a liquid-measure quart when heaped, is the size generally used. It is called the scant-quart box.

**VARIETIES.**—For general planting by beginners there is probably no better variety than Bederwood, for it is hardy and productive even under very trying conditions, but it is too soft for shipping purposes. Its flowers are bi-sexual and produce plenty of pollen for its own and other flowers.

Other very desirable kinds are among pistillate sorts, Crescent, Warfield, Haverland, and many others. Among bi-sexual sorts are Lovett and others.

In selecting varieties care should be taken to get those adapted to the location in which they are to be grown, as well as those adapted to one's market.

1

### INQUIRIES ANSWERED

**Trees to Plant for Fence-posts.**—E. S., Seymour, Ind. I think that probably you will find *Catalpa speciosa* the best tree for your purpose. You can buy seedlings one year old for \$5 or less a thousand. These should be planted about two feet apart in rows eight feet apart if the land can be plowed. On other land plant so they will come about four feet apart each way.

**European Larch-wood.**—A. P., Ashkum, Ill. The wood of the European larch is used largely for framing, floor-timbers, masts, spars, and it is a valuable tree. It is very highly esteemed in Europe, where it is used largely in ship-building. It makes good fence-posts when the bark is taken off and it is well cured. However, young larch is often so largely made up of sap-wood that it does not last well in the ground, but when old and largely heart-wood it is very durable.

**A Humbug.**—A party in New York sends us a powder which he says will prevent plum and cherry trees from having the disease known as "black-knot." His directions for using it are that a hole should be bored in the trunk of the tree and half of a powder put in and the hole plugged up. This, he says, should be done once a year, and is a sure cure for the trees affected with black-knot, and will prevent further injuries from this trouble. If this were true it would mark a great discovery in the treatment of fungous diseases on plants; but there is not a word of truth in it. Many of our brightest botanists have experimented in the treatment of plant diseases in this way, and have found their labors in vain. The best treatment for plum-knot now, as it always has been, is to cut off and burn the affected wood, and where bad wounds are made upon the trunk in so doing cover with thick Bordeaux mixture. The powder has been analyzed for us. The material of which it is composed is found to be largely sulphur and saltpeter, and about a tablespoonful is recommended for each tree. The charge for using it is fifteen cents a tree a year. It will therefore be seen that it is probably an attempt to make money off of what Peter Henderson used to call the "gullible" portion of the community.

**Spraying—Time to Plant Fruit-trees.**—J. A. S., Bucyrus, Ohio. The proper time for spraying will depend upon what you intend to spray for. If you intend to spray apples for codling-moth the spraying should be done just before the flowers open, and again just after the flowers fall, and twice more at intervals of two or three weeks. For this purpose use Paris green and water, one part to one hundred and fifty gallons of water, and add one pound of quicklime. Do not spray until the flowers are open. Kerosene and water can only be successfully applied with a specially prepared spray-pump. It will not do to put the kerosene and water in the same tank and use them with the same pump, for the kerosene will float to the surface and will not mix with the water. The use of kerosene and water as an insecticide is new, and it has only been successfully used since special pumps were made for this purpose. The best style of pump is one that has the kerosene and water in separate vessels and a pump for each, and they are mixed just as they leave the machine. The proportion of kerosene will vary according to the purpose for which it is intended. It is especially useful for destroying plant-lice.—The best time for planting fruit-trees is in the spring as a rule, and for beginners it is by far the safest time. However, our hardier kinds of trees may safely be planted in the fall if considerable care is used in setting them out. In even very severe locations fall planting can be successfully practised by laying the tree flat on the ground after planting and covering with earth. It is of course more work to plant in this fashion, but it saves labor in the spring, which is the time we are apt to be most crowded.

**POTATO-PLANTING PROBLEMS.**—A reader in California asks me to state whether it is a good and safe thing to plant small potatoes, and whether the crop will be as good as from large potatoes. A week or two ago I noticed in "American Gardening" a long article on potato-growing, in which the writer stated that the continued use of small tubers for planting would surely lead to the running out of that strain of potatoes. I think it depends on circumstances. A small currant-cutting does not always make the smallest currant-bush, a small peach-bud not always the smallest peach-tree, nor does it follow that a small cutting of a geranium or of a tomato-plant makes small and weak plants. In our customary way of growing potatoes—namely, by planting a tuber or piece of tuber—we simply make use of a kind of propagation by cutting or bud. A potato is a thickened underground stem, not a root. If this stem is healthy and well developed it is good for propagation, no matter whether large or small.

\* \* \*

In order to grow the largest crop of potatoes we must first of all aim to have strong individual plants. To secure such we must above all else have the seed-tubers in well-preserved condition, with all their vitality intact. The tubers must not be frosted nor weakened by the production of long, spindling and worthless sprouts, which one usually finds on potatoes kept in the cellar or in tight boxes or barrels until the planting season. Fresh, well-kept small potatoes are therefore worth a good deal more for seed than large potatoes weakened by one or the other of the causes named. The best way to treat any potatoes intended for planting, whether large or small, is to keep them cool and well exposed to the light for some weeks prior to planting, even in subdued sunlight, as under a tree in the yard or orchard, but if possible in single layer only, so as to have them start strong, stubby, dark-colored sprouts up to half an inch or so in



THE TOTAL ECLIPSE OF MAY 28, 1900

[CONTINUED FROM FIRST PAGE]

Astronomical parties from several of our universities and some from Europe will observe the eclipse at stations now being selected for the purpose. Congress has made an appropriation of five thousand dollars, and the Smithsonian Institute a like amount for the expense. Preparations have been going on for many months; the most carefully and skilfully made instruments for quick and accurate work known to science are to be used, and if ever moments are golden it is here, for the exact moments of contact must be noted, photographs of the totality secured, the lines in the spectrum of its light sought and recorded, the planet Vulcan or other inferior planets must be seen now or never, or a stray comet caught on the wing if one be sweeping through our solar system, and all this must be done in less than two and one half minutes. A lost opportunity would be criminal, and there are less than two and one half hours for such observations all told in a century's eclipses.

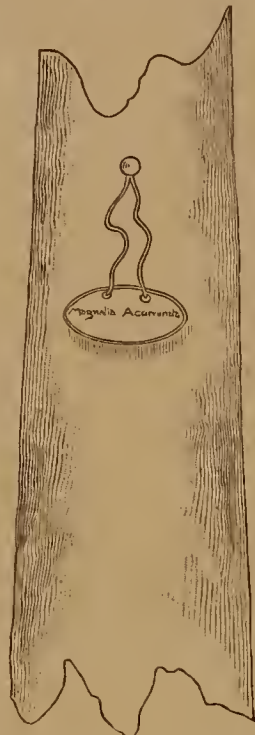

It is not merely as a spectacle of imposing grandeur that we view a total eclipse, but it is one of the greatest scientific interest, as throwing unexpected light on the physical constitution of the sun. If night can give us a surprise by revealing countless worlds, the eclipse can also surprise by revealing a new glory of the sun. When the eclipse is perfect or during totality a corona or halo bursts forth like that which the old masters gave to the heads of the saints. This corona has been observed to consist of two zones or strata. The innermost is the brightest and the light is nearly uniform; the outer zone is diversified by radiating beams. The most remarkable and baffling phenomenon is the rose-colored prominences seen in the innermost zone. These affect curious shapes; one seen in the eclipse of 1851 has been designated the Boomerang, another the Balloon; others compared to the teeth of a circular saw, others the flames issuing from the top of a burning house and driven aside by the winds. Some of these prominences resemble cones with the sun as a base, others lean at an angle of forty-five degrees. That the rose-colored prominences are not flames must be concluded from the fact that many of them are three or four hundred times as large as our globe. In the eclipse of 1851 and 1860 De La Rue, a French astronomer, photographed the sun, and many such photographs have been taken by later astronomers. But the crowning glory of the astronomer is not in the exact measurements of the heavenly bodies, nor in photographing their surfaces and mapping their continents and seas, but in this: He has brought to the aid of the telescope the chemical analysis of light by the spectroscopy. The constitution of the heavenly bodies which has previously been a matter of conjecture to a limited extent has become something of definite and positive knowledge. Our sun and the fixed stars are now known to be bodies constructed upon a general plan, consisting of a solid or liquid nucleus heated to a temperature of the brightest whiteness surrounded by an atmosphere of somewhat lower temperature. This analysis reveals beyond a doubt that there are in the atmosphere of the sun forty-one of the chemical elements which are common to us, and there are other lines in the spectrum which thus far have not been determined. This may indicate that there are other elements in the sun's atmosphere not found in the earth, or that these elements have not been known to our chemistry.

"There are more things in heaven and earth, Horatio, than thou hast dreamed of in thy philosophy."

FARM WORK AND WAGES

"Rakehandle" says farm labor is "tough, rough and tougher." I say yes on farmer and laborer alike, for want of a better method. He says for the year he receives \$115, or 37 cents a day. Add \$10 a month for board he made \$235, or 75 cents a day; that is, if he worked all the 313 days, which is certainly

very exceptional. Say farm-work is delayed by unfavorable weather one fourth would reduce his working days to 235, or \$1.00 a day. I find one third to be nearer the point. "Rakehandle" says it is push from daylight till dark. This is just what makes farming the reverse of what it ought to be. Other industries are carried on very differently. A day's work on a farm ought to be from six A. M. to six P. M. After that, if work must continue, overtime ought to be allowed. If farming is done studiously it will pay; but loose, sloveuly farmers cannot make farming pay if wheat sells for \$1.00 a bushel and corn 50 cents a bushel. I know one who won't allow his hands and teams to be out longer than from six till six, and out of debt, too.

J. W. H.

ATTACHING LABELS TO TREES

There is only one way by which tree-labels or any attachment can be made to a living tree that will not provoke serious resistance from the new annual layer of wood-cells, and that is by allowing a length of wire, which is to be permitted to grow into the tree with the increase in its annual girth. The illustration explains this so clearly that further description is unnecessary.—Meehan's Monthly.

CORRESPONDENCE

FROM WASHINGTON.—In the correspondence column of the FARM AND FIRESIDE of April 1st is a letter from A. P., Seattle, Wash. I would like to correct a few statements he has made, as I have lived for twenty years in what he terms the eastern part of Washington—termed here the Inland Empire. He says wheat and other grains do not yield well here without irrigation. The amount of No. 1 wheat raised in the Inland Empire in 1897 was something over 6,000,000 bushels; in 1898, about 6,000,000 bushels; in 1899, 5,500,000 bushels, all without irrigation. The only irrigation used in the Inland Empire is in Walla Walla and Yakima counties for alfalfa meadows, yards, orchards and gardens. Wheat-lands are rated at from \$10 to \$40 an acre, grazing-lands from \$1 to \$10, orchard, garden and hop lands from \$40 to \$200, according to location and distance from market. A good farm-laborer gets from \$20 to \$30 a month by the year; harvest wages are from \$1.50 to \$3 a day. There is still some vacant government land for home-seekers in Whitman and Adams counties. Railroad lands sell at from \$1.25 to \$10 an acre. The wheat yield is from 15 to 60 bushels an acre, oats 40, barley from 40 to 80, and corn from 20 to 40.

J. L. S.

Lacrosse, Wash.

FROM OREGON.—As I have never seen in the FARM AND FIRESIDE anything from the Umpqua valley, the fairest and most fertile spot in Oregon, I will try to give a short description of it. The climate is unrivaled, both for pleasantness and health. The valley extends along the line and a little north of the forty-third parallel north, which gives it that intermediate climate between the heavy rains of the north and the drought-stricken land on the south. It is also surrounded by mountains on every side, breaking the force of storms from every direction. I believe I can say with entire truth, after living here more than forty years, that there are more pleasant days in the year here than in any other place in the United States. There is an even temperature both summer and winter, which makes life worth living. Not enough snow fell during the past winter on the level valleys to whiten the ground, and but little on the hills and mountains. Cattle have kept in good condition in their winter pastures, with no feed other than the native grass of the hills. The valley is surrounded on all sides by fir-covered mountains, and within these boundaries an interior collection of hills, with a growth of scattering oak timber and fair pasturage. The level valleys lying along the streams are narrow, but very fertile, and produce all the fruits and vegetables of a temperate climate in perfection. Prunes are now rather the leading fruit grown, but pears and apples are also extensively raised, and where properly cultivated on suitable soil are very profitable. I suppose the big red apples of Oregon are known everywhere, but they should be seen and tasted to be appreciated. One of my neighbors sold last fall \$2,700 worth of dried prunes from less than twenty-seven acres of young trees, and another man living near the same place sold over \$1,600 worth of Bartlett pears picked from eight hundred small trees. These orchards were both on very rich soil worth at least \$50 an acre. Cattle do well here, and young calves are easily raised, owing to the mild winters. Calves from eight to nine months old sold last fall as high as \$17 a head. Stock-buyers come here to recruit their herds in Montana and other parts of the great plains, where the rigors of the climate are often fatal to young stock. Land here is cheap, although this valley has been settled for more than forty years; we had few railroad facilities up to 1882, since which time we have had the benefit of the Southern Pacific running the entire length of the valley from north to south. Land can be bought for from \$5 to \$50 an acre. Crops never fail here and irrigation is not necessary. Bad roads in the rainy season are the greatest difficulty to contend with, the country being thinly settled and the people not being able to make expensive artificial roads, which are a necessity in a country having a rich soil and a rainy instead of a cold and dry winter.

Roseburg, Oregon.

C. W. S.

- ARMSTRONG & McKELVY Pittsburgh.
- BEYMER-BAUMAN Pittsburgh.
- DAVIS-CHAMBERS Pittsburgh.
- FAHNESTOCK Pittsburgh.
- ANCHOR Cincinnati.
- ECESTEIN Cincinnati.
- ATLANTIC
- BRADLEY
- BROOKLYN New York.
- JEWETT
- VLSTER
- UNION
- SOUTHERN Chicago.
- SHIPMAN
- COLLIER
- MISSOURI St. Louis.
- RED SEAL
- SOUTHERN
- JOHN T. LEWIS & BROS CO Philadelphia.
- MORLEY Cleveland.
- SALEM Salem, Mass.
- CORNELL Buffalo.
- KENTUCKY Louisville.

**W**HEN you see the paint cracking, peeling or falling off the house in shreds, you may be sure it was *not* painted with Pure White Lead, but with some mixture of Zinc, Barytes, etc.

Pure White Lead unites with Linseed oil to form an elastic coating that never cracks nor peels. It is the good, old-fashioned paint that lasts. To be sure of getting Pure White Lead, see that the package bears one of the brands named in margin.

**FREE** For colors use National Lead Company's Pure White Lead Tinting Colors. Any shade desired is readily obtained. Pamphlet giving full information and showing samples of Colors, also pamphlet entitled "Uncle Sam's Experience With Paints" forwarded upon application.

National Lead Co., 100 William Street, New York.

No. 58 Handy Buckeye Cultivator

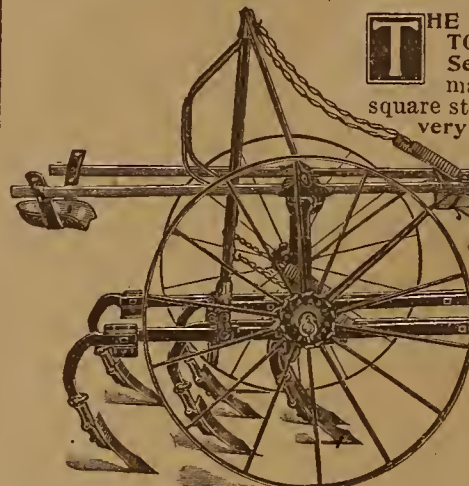

**T**HE No. 58 HANDY BUCKEYE RIDING CULTIVATOR is made with Pendulum Beam and Hammock Seat, with six small shovels, pin shovel. The main frame is bent "U" shape and is made of square steel tubing, and is in One Piece, which makes it very strong and simple. The axle is adjustable, so that the machine can be narrowed or widened as desired, and has single tongue. The shovel standards can be set closer together or wider apart, and raised or lowered for the cultivation of corn or cotton that is planted in deep furrows or ridges.

This Cultivator is BUILT ON WELL-KNOWN PRINCIPLES which are thoroughly established by years of practical operation on Cultivators of this type, and are manufactured under patents covering the important features, so that customers will run no risk in purchasing Cultivators of this type from us. Manufactured by

P. P. MAST & CO., No. 17 Canal St., Springfield, Ohio, Philadelphia, Pa.

**Big Buggy Bargains.**

Because we sell Vehicles and Harness at less than wholesale prices we are in a position to offer you the highest bargains procurable in our line. To make you perfectly safe

**WE GUARANTEE ...Everything We Sell...**

and ship our goods anywhere subject to purchaser's inspection. If entirely satisfactory and exactly as represented, you keep the goods and send us the money. If not, you return the goods at our expense. Have Carriages, Sarriges, Phaetons, Traps, Buggies, Road Wagons, Spring Wagons, etc., and all styles single and double harness. Catalogue free. Kalamazoo Carriage & Harness Co., Box 86, Kalamazoo, Mich.

**FREE! SEND NO MONEY**

**TO LADIES, BOYS AND GIRLS**

We send this elegant solid gold or sterling silver plated bracelet, beautifully engraved, with a dainty little lock and key, also 3 extra gold or silver Friendship Hearts, for selling only 5 sets of our latest style 14-karat gold filled Ladies' Dress or Beauty Pins at 25c. a set. Each Pin is set with an exquisite large jewel; or will send this solid gold shell latest style set ring for selling 5 sets. Our rings are set with an exquisite Ruby or Emerald stone, and they are hard to tell from a \$5.00 ring. Send us your name and address only, no money, and we mail you the Pins post-paid. After you sell them among your friends and neighbors, send us the money, and we will send you your choice of the above presents, or many others which you will find in our Large Premium Catalogue of Watches, Jewelry, Tea and Dinner Sets, etc., free with each lot of Pins. You will find these Pins the fastest seller you ever handled. Every stylish lady and girl in the land will buy several sets at sight. We sell over a million each month. This is an honest offer by a strictly reliable house. We take back all you cannot sell, and pay postage on goods and premiums. Don't fail to take advantage of the grandest offer ever made! Write to-day; don't put it off!

This firm is well known for its honest goods and valuable premiums. ST. LOUIS PREMIUM CO., Dept. A 28, St. Louis, Mo.

**You Pay Double the Money**

In many cases when you buy vehicles and harness from the agent or dealer. We do without these people and reduce the price of our goods to you to the extent of their commissions. We make 178 styles of vehicles and 65 styles of harness and sell them to the consumer direct from our factory at wholesale prices.

**WE HAVE NO AGENTS**

You pay a profit to nobody except our manufacturing profit, and you get positively the best goods which a given amount of money will buy. In a factory of the size of ours you get the best possible selection. Our large Illustrated Catalogue contains cuts of everything we make. Remember that we ship our vehicles and harness anywhere for examination and guarantee safe delivery and warrant everything.

**SEND FOR LARGE FREE ILLUSTRATED CATALOGUE.**

**ELKHART CARRIAGE & HARNESS MANUFACTURING CO., Elkhart, Indiana.**

**WANT A WATCH?**

You can secure a valuable watch absolutely free. Send us your name and address and we will send you by return mail your endless-chain ticket and ten tickets which you are to sell to your friends for 15 cents each, remit the \$1.50 to us, with the names and addresses to whom you sold, and we will send them a supply of tickets like those sent you. When your chain is completed usually 2 to 3 weeks, we will send a watch of your own selection FREE. Watches guaranteed value \$15. No lottery. Square dealing guaranteed. Address

**BOYLSTON & BENT, Rochester, N. H.**

**1900 HIGH GRADE**

**YOU CAN EASILY EARN**

bicycles, sewing machines, house furnishings, ladies' or gentlemen's watches, cameras, mandolins, guitars, violins, silverware, dinner sets, guns, and your choice of a hundred other articles, all guaranteed. Simply sell a few boxes of our unexcelled toilet soaps and any of them are yours. Send no money. We trust you. Girls and boys do as well as older people. Write at once for full information. We mail handsome illustrated catalog free. Address Great Northern Soap Works, 92 Lake St., Oak Park, Ill.



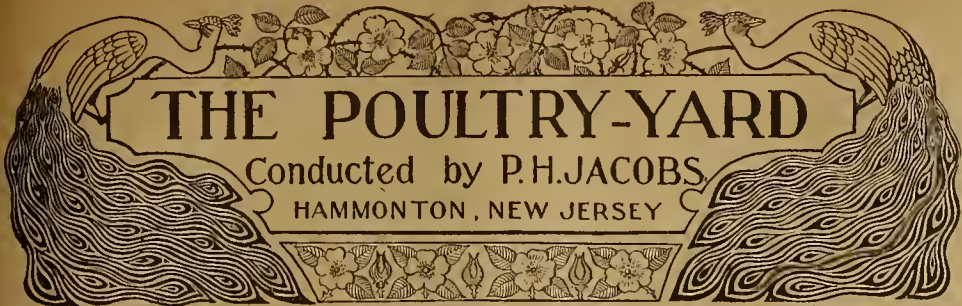

MILK, MEAT AND GRAINS

WHEN wheat contains eighty-five per cent of dry matter (fifteen per cent being water) the eighty-five pounds of dry matter would be, at \$2.00 a hundred pounds, about two and one third cents a pound (deducting the water). Milk at three cents a quart is about one and one half cents a pound, hence one hundred pounds of milk would cost \$1.50, of which about fifteen pounds (at the highest) would be solid matter. Milk averages about twelve pounds of solids a hundred pounds. The grain is probably cheaper, but the milk solids are more complete in the food elements. Bran is cheaper than either, and to economize in feeding the bran should be given by mixing the soft food with milk. Milk is not sufficiently concentrated, hence the hens cannot drink enough of it to satisfy them, so far as solid matter is concerned. Milk (one hundred pounds) contains 3.41 pounds of flesh-formers and 11.23 pounds of heat-producers; skimmed milk, 3.06 pounds of flesh-formers and 6.15 pounds of heat-producers; beef, 21.39 pounds of flesh-formers and 9.08 pounds of heat-producers. One analysis of milk showed 14.64 pounds of solid matter, the balance (nearly eighty-six pounds) being water. Of the 14.64 pounds only 3.41 pounds were albuminoids (flesh-formers), the balance (11.23 pounds) being heat, fat and bone producers. Skimmed milk has a little over three pounds of flesh-formers and about half as much heat-producing matter as fresh milk. Beef (lean) has nearly seven times as much flesh-formers as skimmed milk, and not as much heat and fat as fresh milk. Now, the point to be noticed is that in order to secure three pounds of flesh-formers the fowl must drink one hundred pounds (nearly fifty quarts) of milk. Hence, one hundred pounds of lean meat give nearly the same results as seven hundred pounds of skimmed milk (about three hundred and fifty quarts). Beef also contains about seventy pounds of water in its composition. Milk will not, therefore, answer strictly in place of meat, as it is not concentrated. In other words, the hen could not drink enough of it, owing to its bulk, to derive the same results as from meat.

Milk can be fed to poultry in any condition, either as skimmed milk, buttermilk, curds or when mixed with meal or ground grain of any kind. It is a valuable food for egg production, being rich in albumen, and supplies many substances that may be lacking in other foods. It is cheap on those farms where only the cream is desired, and it will give better results with poultry than when fed to pigs.

JUDICIOUS FEEDING

The matter of feeding is one that cannot be understood except by experience. A hen will fatten more readily than a growing pullet, and a laying hen requires more nitrogenous food than one that is not laying. The amount of food given is no evidence of the digestible capacity of the fowl. Some hens may eat less than others, yet digest more. It is these several factors that serve to render it difficult to select a ration for a flock. Individual characteristics, the condition of the fowl, age, breed, shelter, kind of range, confinement and even the grit are matters that regulate both the quantity and the quality, for a hen must not be deprived of what she needs, and she must not be made too fat for a layer. When grass is very young it contains more water than when allowed to mature, hence food that has been allowed to grow until it has approached the stage of maturity contains more nutritious matter than that which has been cut in the earliest periods simply because the nutrition intended for the formation of the seed is arrested in the stalks. Green food, therefore, should be such as has not been matured sufficiently to complete the seeds, though the seeds may be in a milky state. When grain is fed exclusively a deficiency of the mineral matter and nitrogen may result, which deficiency is supplied by a variety of other foods. Bulky food dilutes the concentrated grain food, thereby promoting digestion and affording the fowls greater opportunities for producing eggs. There is but little nourishment in cabbage,

but there is a dietary effect which more than equals the value of cabbage as food. Corn ensilage is readily eaten by hens, as is known to dairymen who feed it to their fowls, and the eating of the ensilage by poultry is not because of the ensilage being superior to grain, but for the reason that the hens find it an agreeable change from the usual dry food, and because it also adds bulk and promotes digestion.

CAUSES FOR UNSUCCESSFUL HATCHING

When eggs are being incubated there will always be some that will not hatch. If eggs fail under a hen it seems to be accepted, but if in an incubator the cause is demanded. Chicks die under hens as well as in incubators. Put ten eggs under a hen and at least two (on an average) will fail to hatch, the chicks dying in the shells. This seems but a slight loss and it is not noticed, but in an incubator it is twenty chicks in every hundred eggs. Bear in mind that no two chicks are alike. When some of the eggs hatch it proves that the conditions, so far as the incubator or hen is concerned, were correct, for unless so none of the eggs could possibly hatch at all, those not hatching being inferior to the others or lacking in some essential requisite to success. Why the eggs may not hatch and the chicks die in the shells must be sought for where the cause cannot easily be discovered. The hens that laid the eggs may be too fat (which causes weak chicks or none), the males may be too young, the eggs may be from immature pullets or inbred fowls, or from hens that may be diseased. The difficulty is not with the incubator or hens, but with the eggs. The eggs used may be from many different hens, and indeed it will be a surprise if one could succeed in securing a full hatch when there are so many parents to the eggs and so many conditions that are unknown which must be met.

THE LEGHORNS

Many inexperienced persons are desirous of knowing if there is any difference between the single-comb and rose-comb Leghorns in regard to laying qualities, and if both breeds are distinct from each other. So far as the single-comb Leghorns are concerned they have been so uniform of late years as to render them true to all the points required, but among the rose-comb varieties an occasional single-comb chick will come, which shows that at some time a dash of single-comb blood must have been infused, or that the rose-combs are "sports" of the single-comb. No breed is known, however, from which any breeder can secure a majority of birds fully up to every detail required, and hence an occasional "sport" may sometimes be overlooked, but it occurs very seldom among the single-combs.

CHICKS ON DAMP LOCATIONS

Chicks will have weak legs when kept on damp ground or when they are on a damp place at night, as well as when sulphur is given, but when chicks are apparently healthy, have good appetites and grow rapidly weak legs may be caused by forced feeding, their growth being so rapid that the legs are incapable of supporting their bodies. In such cases no danger need result; in fact, it is a favorable indication as showing rapid growth. Simply feed less, giving bone-meal and plenty of finely chopped green food and using millet-seed in the litter, so as to induce them to scratch.

OVERFEEDING

The main point in feeding is not to over-feed; that is, do not feed hens in the morning from the trough. The warm mess in winter is a good plan, especially early in the morning, and enough food should be allowed, but only one half of the food should be given in the trough and the other half as whole grain scattered in some kind of litter. The hens should never be fed so as to permit them to "loaf around," but must be hungry enough to scratch for more. No food should be given at noon unless it be a pound of chopped lean meat, for twenty

hens. About an hour or more before night scatter grain for the hens to pick up. Give enough, but make them scratch for it. If too much feed is given, with no work on the part of the hens, they will become too fat to lay as many eggs as they should.

THE YARDS AND DROPPINGS

At this season on heavy soils the droppings should be removed and scattered on the garden plot, which is the best disposition to make of them. They will not breed lice in winter, but do serve as lice-harbors in summer. The ground for hens should be spaded as soon as any signs of filth appear. The best mode is to have two yards to each house, grow green food in one and allow the hens in the other, changing the fowls occasionally, which will compel spading of the yards. On sandy soil the fowls need not be changed frequently. In winter the frosts may prevent spading, but the yards should then be scraped and sprinkled with a weak solution of carbolic acid or the Douglass mixture reduced in strength.

A MILLION DOLLARS A DAY

The poultry interests in this country now aggregate over three hundred million dollars a year, and a well-advised statistician predicts that when the returns of the census of 1900 are in they will show that "the hen" produces one million dollars a day. Big thing, isn't it? It makes some industries large enough to be a basis for stock-gauging to sink into insignificance. But you can't very easily corner the hen. She is "too fly."—National Stockman and Farmer.

CORRESPONDENCE

WHAT A LADY DID.—I wish to give my experience and success as a poultry-raiser for the year 1899. I started with 135 hens, and sold \$212 worth of eggs, also \$28.35 of chickens, and \$138.65 of turkeys; total, \$379. I had to buy all the feed and corn, which cost me \$1.25 a hundred, wheat \$1.50 a hundred, and the feed all told cost \$181.60. This I did besides all my house-work, and sold \$139.35 worth of hutter and milk. Is there a reader of the FARM AND FIRESIDE who can beat it? Santa Anna, Texas. MRS. S. A. G.

RECORD OF SIXTEEN HENS.—I will state what sixteen hens did for me from January 1, 1899, to November 1, 1899. They laid 1,911 eggs, of which I sold 1,224 for \$13.50; used 487, value \$4.87; set 200, value \$2.00; kept nine chicks, value \$2.25; killed ten chicks, value \$2.50, and sold chicks to the value of \$21.80; total, \$46.92. I bought 900 pounds of bran, corn and middlings for \$7.90; set 200 eggs, \$2.00; pasture, etc., cost \$3.00; and other expenses, \$2.02; total expenses, \$14.92; profits, \$32.00. In this trial the hens did all the hatching. At one time I had nine sittings. The eggs did not hatch well. I fed the young chicks sour-mash, and from the first lost only two by sickness. My medicine is spirits of turpentine, about a teaspoonful for six quarts of mash. I have fed in this way for two years, and have had good success. Breedsville, Mich. C. B. H.

INQUIRIES ANSWERED

**Heads Naked.**—E. M., West Pullman, Ill., writes: "The feathers are coming out on the heads and necks of my fowls. Is there a remedy?"  
 REPLY:—See reply to inquiry headed "Feather-pulling."

**Incubator Chicks.**—L. A. writes: "My incubator chicks, two weeks old, are dying, first losing the use of their legs."  
 REPLY:—Give kind of brooder, temperature and general management, as a satisfactory reply cannot be given without details.

**Blood Spots in Eggs.**—G. J. E., Corning, N. Y., writes: "What is the cause of blood spots in the eggs?"  
 REPLY:—It is due to the rupture of a minute blood-vessel, and is a common occurrence. It will probably pass away if hens are not overfed.

**Feather-pulling.**—W. A. R., Ruby, Neb., writes: "My fowls are losing the feathers off their necks. I first noticed it six months ago."  
 REPLY:—The birds are pulling feathers from each other; watch for the guilty ones and destroy them. There is no other remedy except to smear them with tar or use a poultry-bit.

**Soft-shell Eggs.**—C. J. K., Canon City, Col., writes: "1. What should I do with hens that lay soft-shell eggs? 2. I have just confined my Hamburgs; how long before the eggs will hatch true? They have been running at large. 3. I killed a hen and she was very fat; emphysema eggs were very hard."  
 REPLY:—1. It is caused by overfeeding, the hens being excessively fat. 2. About ten days. 3. Due to overfeeding.

**Bowel Disease in Chicks.**—W. R. M., Camden, S. C., writes: "Bowel disease attacked my chicks when two weeks old. In the fall they are attacked by what is styled 'sore-head.'"  
 REPLY:—Vary the food of the chicks. Corn-meal alone is insufficient. Bread containing animal-meal should be allowed; also potatoes, milk, sifted ground oats and millet-seed. For the sore-head one part of cedar-oil and two parts of vaseline has been used with success.

**IT BEATS THE BUGS**

No matter if you have a dozen other sprayers, you will find use for this one. Every farmer, gardener, fruit or flower grower and poultry-keeper should get our

**Vapor Gem Sprayer**

Not so large as some, but the handiest of all. Tank and pump of heavy copper. Will last 20 years. One loading sufficient for an acre of vines. Regular price, \$2. Order immediately and get reduced price, \$1.50, express prepaid. Also agency. Send P. O. order for one now. **WRITE TODAY.**

**FIELD FORCE PUMP CO.,**  
 26 Market St., LOCKPORT, N. Y.

**HENCH & DROMGOLD'S GRAIN FORCE FEED and Fertilizer Drill**

Positively the neatest, lightest and strongest grain drill on the market. Many points of superiority; it is geared from the centre. Quantity of grain and fertilizer can be changed while in operation without the use of gear wheels. Fully guaranteed. Positively accurate in quantity. Give one trial and be convinced. Agents wanted. Circulars free. Address **HENCH & DROMGOLD, Mfrs, York, Pa.**

**ORNAMENTAL FENCE!**

25 different designs, they are all steel and cheaper than wood fence. Special prices to Churches and Cemeteries. Write us for catalogue.

**KOKOMO FENCE MCH. CO.,**  
 427 NORTH ST. KOKOMO, IND., U. S. A.

**NO WHEEL, NO WAGON.**

Wheels generally break down first. It is cheaper to buy new wheels than to repair the old ones when you can get

- 4 Buggy Wheels 7-8 in. Steel Tire for \$7.50
- 4 Carriage Wheels 1 in. Steel Tire for 8.00
- 4 Milk, Delivery, Spr'g Wagon Wheels, 10.50

The best of their kind. Gears and Axles furnished and boxes set. Write for price list No. 31 with directions for measuring. **Wilmington Wheel Co., Wilmington, Del.**

**GOOD FENCE!**

Makes good neighbors. Why not have both when you can make the best for

**20 to 35 Cents a Rod.**

A little inquiry into the merits of our system of fencing will repay you handsomely. Write to-day for free Catalogue.

**KITSELMAN BROTHERS,**  
 Box 278 Ridgeville, Indiana, U. S. A.

**FIRE, WEATHER, and Lightning Proof**

Black, painted, or galvanized metal ROOFING and siding; (brick, rock or corrugated)

**Metal Ceilings and Side Walls**

in elegant designs. Write for Catalogue.

**The Penn Metal Ceiling and Roofing Co., Ltd.,**  
 23d & Hamilton Sts., Phila., Pa., or 24 Hancock St., Boston, Mass.

**EVERGREENS.**

Largest stock in America, including

- Colorado Blue Spruce
- and Douglas Spruce of Colorado.

Also Ornamental, Shade and Forest Trees, Tree Seeds, Etc.

**E. DOUGLAS & SONS,**  
 Waukegan, Ill.

**SAVE IT ALL!**

The butter makers' success depends upon clean skimming—getting all the cream out of the milk, in the quickest, cheapest way. Our improved patent

**AQUATIC CREAM SEPARATOR**

does this. Bests the best creamery made and costs less than half as much, capacity considered. Takes all the cream out of milk in two hours' time. For 1 to 40 cows. Prices \$5. to \$11. Write for FREE Catalogue and testimonials. **AGENTS WANTED.**

**Aquatic Cream Separator Co., 125 Factory Sq., Watertown, N. Y.**

**The IMPROVED VICTOR Incubator**

hatches all the fertile eggs; is simple, durable and easily operated; 168 page catalogue containing information and testimonials. Sent free. **GEORGE ETEL CO., QUINCY, ILL.**

**LEE'S LICE KILLER** CLEANS OUT THE LICE and mites on poultry and hogs without handling fowls or animals. Painted or sprinkled on roosts, bedding or rubbing posts, the Lice Killer does the rest. We prove it with **FREE SAMPLE.** Our new catalogue of Stock and Poultry Supplies free upon request. **GEORGE H. LEE CO., Omaha, Neb., or 68 Murray St., New York**

**DON'T SET HENS THE SAME OLD WAY**

The Nat'l Hen Incubator beats old plan 3 to 1. Little in price, but big money-maker. Agents wanted. Send for cat. telling how to get one free. **Natural Hen Incubator Co., B 22, Columbus, Neb. A. Edwards writes, "Would not take \$100 for N. H. I. Plan."**

**\$2.75 buys a MAPLE AND Baby Carriage**

50.00 buys a Beauty complete with rubber tire wheels and paragon. Full line of Sleeping Coaches and Coaches. 48 page Catalogue Free. Address Dept. 11 **VICTOR MFG. CO.,** 161 to 167 Plymouth Place, CHICAGO, ILLINOIS.

90 Varieties Choice Poultry, Eggs, Pigeons, Hares. Described colored 60-page book, 10c. **J. A. Bergey, Telford, Pa.**

**DEATH to LICE** on hens & chickens. 64-p. Book Free. **D. J. Lambert, Box 303, Apponaug, R. I.**



## VETERINARY

CONDUCTED BY DR. H. J. DETMERS

To regular subscribers of the FARM AND FIRESIDE answers will be given through these columns free of charge. Where an immediate reply by mail is desired the applicant should inclose a fee of one dollar, otherwise no attention will be paid to such a request. Inquiries should always contain the writer's full address. Queries must be received at least two weeks before the date of the issue in which the answer is expected. Veterinary queries should be sent directly to DR. H. J. DETMERS, 1315 Neil Avenue, Columbus, Ohio.

NOTE.—Parties who desire an answer to their inquiries in this column must give their name and address, not necessarily for publication, but for other good reasons. Anonymous inquiries are not answered.

**Anonymous Questions** will not be answered under any circumstances.

**Swine-plague.**—J. S. Giddings, Ohio. Your pigs evidently died of swine-plague (or so-called hog-cholera), and so, undoubtedly, did those of your neighbors.

**Fails to Yield Sufficient Milk from Fore Quarters.**—J. W. M., Armiston, Ala. Please consult answer to J. P., Donnellson, Ill., in the FARM AND FIRESIDE of April 1st.

**Impetigo.**—A. B., Clay City, Ill. Apply to the bald and sore place on the forehead of your horse twice a day a mixture composed of one part of liquid subacetate of lead and three parts of olive-oil. Rub it in with the finger.

**Periodical Ophthalmia.**—T. M., Harbor, Oregon. What you describe appears to be a hopeless case of periodical ophthalmia, or so-called moon-blindness. The inflammatory symptoms will disappear soon after the eyesight of both eyes has been destroyed.

**Periodical Ophthalmia.**—B. M. S., Stull, Pa. What you describe is evidently a case of periodical ophthalmia, a disease which almost invariably terminates in blindness, especially if both eyes are affected at the same time. Therefore, do not blame your veterinarians for not accomplishing anything, but rather for not telling you that any treatment is in vain. The only thing that can be done is to preserve to a limited extent the appearance of the eyes by using an eye-water, a weak solution of atropin in distilled water, say 15.00 or 480, as that will prevent a closing of the pupil, but not save the eyesight.

**Incipient Elephantiasis.**—T. H. B., Staffordsville, Va. Since the swelling of your horse's leg is yet decreasing when the horse is exercised, I advise you to work or to exercise the horse every day, to give the swelled leg a good rubbing down every evening as soon as the exercise or work is over, and then to apply a bandage of woolen flannel, the winding to be begun at the hoof; to remove the bandage in the morning, then to give the swelled leg another rubbing down, and to exercise the horse or to put the same to work again. During the rest at noon another rubbing will be beneficial. Continue this treatment every day until no more decrease in the swelling can be observed.

**Best Time to Castrate Bull-calves.**—J. W. S., Deer Lodge, Tenn. The earlier the calf is castrated the finer will be the steer; but there is also a limit to it. In a new-born calf the testicles are often very small, soft and flabby, making a neat operation rather difficult. Therefore, it is not advisable to perform the operation until the parts to be removed are firm enough to enable a neat operation by which the scrotum will be fully preserved. Any butcher and any dealer in fat cattle will explain to you the reason why this should be the case. It is impossible to give the proper time in days and weeks, because the organs in question do not show the same degree of development in all calves at the same age.

**Paralyzed Cheeks.**—L. W. G., Lodi, N. Y. The trouble of your lamb, or the inability of the same of moving the masticated food away from behind the teeth back upon the tongue, and to form it into morsels to be swallowed, is caused by a paralytical condition of the muscles of the cheeks, or, more correctly, by a paralysis of the nerves governing the muscles of the cheeks. If the paralysis is limited to the facial nerves and does not extend to the trigeminal a recovery or at least an improvement is possible, if, as is usually the case, the paralysis is one-sided. What will be the outcome where the paralysis is on both sides I cannot tell you. If you desire to save the lamb, and if the same cannot swallow enough common food to sustain life, I would advise you to feed semi-fluid or sloppy food until sufficient improvement has taken place to enable the animal to swallow some food. A one-sided paralysis of the facial nerve in a horse usually disappears in from six weeks to six months.

**A Stiff or Paralytic Brood-sow.**—B. C. L., Aquarium, Mich. In your case the trouble is undoubtedly caused by a very defective diet. According to your own statement you fed your sow exclusively, or almost exclusively, on shorts, a kind of food almost destitute of certain elements absolutely required by the animal organism. The sow may have got along as long as she had only to provide for herself, but when she had to produce and to raise a litter of pigs the demands on her resources became too great, much greater for certain elements—phosphates, lime salts and nitrogenous compounds—than the food she received could supply. Hence, her own organism, becoming robbed of these substances, had to break down. It may be too late to restore her to her former condition. If it is not, wean her pigs and make a thorough change in her diet. Feed oats, bran, no shorts, clover, etc., and substances rich in phosphates, lime salts and nitrogenous compounds; but as the digestive powers have also become weakened, see to it that the food you offer is easy of digestion.

**A Good Place for a Veterinarian.**—R. M. M., Newport News, Va. There are undoubtedly many good places for a competent, well-educated and industrious veterinarian in our big and prosperous country, particularly in Oregon and the whole Pacific slope, but I am not in the position to point out a particular place, and would not recommend any one unless convinced that he would "fill the bill in every respect."

**Unclean Skin.**—B. G., Flora Dale, Pa. It does not appear from your communication that the skin of your horse, "always appearing like covered with a substance that looks like dust [so that] no amount of currying will make it clean," is diseased. It may be that you use the curry-comb too much, and use it where the brush should be used, and thus keep the skin constantly in a state of irritation, resulting in an abnormal production of epithelium scales constituting the dustlike substance. It may also be that your horse is one of those dull black, dun or mouse colored animals which naturally produce such an abundance of epithelium scales that they never can be kept clean, and are hated by every groom.

**Purulent Discharge from the Nose.**—H. S., Scott's Mills, Oregon. It is not common for cows to have a purulent (matter) discharge from the nose; on the contrary, such a discharge is a sure indication of the existence of some morbid process somewhere in the respiratory passages, or in the lungs themselves. As the nature and the seat of these discharges cannot be learned from your communication, I can neither tell you the cause nor prescribe a remedy. Concerning the cause there are too many possibilities, and among them I will only mention a severe catarrhal affection and tuberculosis. If it is tuberculosis, the disease must be in an advanced stage, and then, of course, it would not be safe to use the milk.

**A Sore on the Tongue of a Cow.**—D. Y. M., Chadron, Neb. The cause and the nature of the sore (perhaps ulcer) on the tongue of your cow cannot be learned from your description, consequently I can advise you only in a general way. If the sore has not yet healed when this reaches you, you may, with a good show of success, treat it in the following way: Get a small so-called surgeon's sponge, tie it securely to a stick of convenient length, dip the sponge into a three-per-cent solution of either hydrochloric or carbolic acid in water, draw the tongue of the cow sufficiently out of her mouth so that the sore is in plain sight, and then wash the latter out with the sponge saturated with the solution. Do this twice a day until a healing has been effected.

**About Skunks.**—J. M. F., Athens, Ohio. You ask, "Are quails, quail-eggs, chickens and hees killed and eaten by the skunk or polecat?" Answer: That skunks kill chickens I positively know; that they kill and probably eat quails and their eggs I do not doubt in the least, but whether they also eat hees I do not know. You ask further, "About when is the breeding season of the skunk or polecat in the latitude of southern Ohio?" Answer: All the answer I can give you to this question is that I have seen four young, probably half-grown, skunks follow an old one, apparently their dam, in the forepart of the summer, and I think it must have been in June, but the exact date and even month I am unable to give. It was very close to the fortieth degree of latitude.

**Several Questions.**—M. C. H., Lincoln, Neb. Your first question I cannot answer, because to feed oil (cake) meal to a working-horse or a roadster can be sanctioned only if it is done for a special object. If you intend to use it as a regular food I would say, feed none at all. 2. The age of a horse can be ascertained by the condition, shape and length of his teeth, particularly of the incisors; but don't ask me to give you the whole doctrine, because to do this would require quite a lengthy treatise and numerous illustrations filling half a dozen pages of the FARM AND FIRESIDE. 3. The nutrient value of wheat-bran is about the same as that of very good hay, while the nutrient value of rye-bran is somewhat higher; but for other reasons it will never do to make bran the exclusive or the principal food of horses.

**Stomach-worms.**—M. A. E., Jacksonville, Tenn., and H. S., Scott's Mills, Oregon. Stomach-worms in sheep and lambs (*Strongylus contortus*, Rud.) will be expelled if the sheep and lambs, after they have been fasted for about twelve hours, are slowly drenched with a solution of tartar emetic in distilled water of the strength of one of the former to ninety-six or one hundred of water. The proper dose for a lamb is, according to age and size, from half an ounce to one and one half ounces of this solution, and for full-grown sheep about two ounces. The drenching must be done in such a way that the fluid will pass down very slowly, and thus will pass directly into the third stomach, the dwelling-place of the worms. After having been drenched the lambs and sheep should fast again for at least a few hours.

**Insufficient Perspiration.**—G. McG., Latham, Ala. An insufficiency of perspiration and an abnormal dryness of the skin are not seldom observed in horses affected with chronic diseases of either the skin or of internal organs, and also of horses suffering from too abundant discharges through the intestinal canal (diarrhea), or through the urinary organs. A cure is possible only if the cause can be ascertained and can be removed. In some cases, especially in such in which an irritation or a too great activity of the urinary organs constitutes the cause, small doses of triturated camphor mixed with the food (some horses will refuse to take it in that way) will effect an improvement. The skin itself may also be excited to greater activity by frequent and thorough brushing and by covering with blankets.

**Damaged Hoof.**—T. H. R., Laurel, Neb. Since the injury by which the matrix of the wall-horn of the hoof was destroyed or seriously damaged happened as long as four years ago, it is not very likely that anything can be done now beyond protecting the defective part of the wall of the hoof as much as possible by judicious shoeing. If anything more is to be attempted it must be done by a competent veterinarian who is perfectly familiar with the anatomy, physiology and mechanism of the horse's hoof.

**Lameness Brought on by Exercise.**—C. S., Buxton, N. D. The apparently peculiar lameness in one of the hind legs of your horse, developing when the animal is exercised or at work, but disappearing when the same is resting, or has been resting for awhile, is undoubtedly caused by a partial obstruction, probably an aneurism, in one of the principal arteries providing the affected leg with blood. Although it is not impossible that in time either an improvement or an aggravation will take place, the case must be considered as incurable. At any rate, nothing whatever can be accomplished by any medicinal treatment, and surgical operations are also out of the question. It is possible that moderate exercise will have a good effect, provided it is never carried on too far.

**Haematopinus piliferus.**—N. L., Anthony, R. I. What you describe is the dog-louse, *Haematopinus piliferus*. It is a blood-drinker, as the name indicates. Since warmer weather is coming it may be advisable to have your dog clipped or shorn. This done, give him a good wash with soap and warm water, then mix twenty drops of oil of anis with half an ounce of olive-oil and rub it in on the dog wherever there are lice. If this is done in the morning apply another wash with soap and warm water in the evening. Then next morning, if not all the lice should have disappeared, another dose of oil of anis and olive-oil may be applied, to be washed off again in the evening. At the same time the sleeping-place of the dog must be thoroughly cleaned and disinfected, for if this is not done the treatment will very likely be in vain.

**Lice on Horses.**—L. A., McKittrick, Mo. Horses can be freed from lice if first thoroughly washed with soap and warm water and then either with a tobacco decoction or with a four to five per cent solution of creolin in water. The second wash must be repeated in about five days in order to dispose of young lice hatched from the nits that were not destroyed by the first washes. But all these washes will only have a temporary effect, and will do very little good unless the premises are at each washing thoroughly cleaned and disinfected, and then kept clean. The horses at the same time also must be well fed, be cleaned and groomed every day, and then kept clean. Lice, like nearly all other parasites, are the more thrifty and propagate the more rapidly the more their host is declining. Animals that are well fed and in every respect well-kept are seldom lousy. Lice may be communicated to such an animal, but they do not seem to feel comfortable, and will soon leave.

**Rabies.**—W. O. W., Tulls, N. C. You say that a sow that had been bitten by a mad dog began to show symptoms of rabies thirteen days after she had been bitten; that her litter of pigs, which had not been bitten by the dog, was three days less than a month old when the sow became diseased, and that the owner of the sow and pigs removed the latter as soon as he saw that there was anything wrong with the sow. The sow, although you do not say so, it must be supposed died within a week after she was taken with the disease. Now, you ask whether the pigs will be in any danger. This, as far as I can see, will depend upon whether the sow wounded them in any manner whatever by biting, even if it amounted only to a slight scratch or abrasion of the epidermis. It must be kept in mind that the infectious principle of rabies is oftener conveyed through slight lesions or abrasions than through freely bleeding wounds. It also has been ascertained that the infectious principle is present in the saliva of an infected animal already a few days before the disease—rabies—comes to a plain outbreak, or before characteristic symptoms of rabies manifest themselves. It has also been shown by the investigations of Pasteur and his associates that the virus, besides in other organs, is also present in the mammary glands, consequently the possibility of an infection through the milk of a rabid animal introduced through a wound, sore or abrasion into the organism of a healthy animal is not excluded. Nocard, Roux and Bardach succeeded in producing the disease in healthy animals by intracranial injections with the milk of rabid animals. Consequently, although there is no reliable case on record in which rabies was produced or communicated by introducing milk, meat, brain substance or even saliva of a rabid animal into the stomach of a healthy one, it cannot be denied that the disease may be produced by a consumption of infectious material—milk, for instance—if there is in the mouth or anywhere else in the digestive tract a sore or wound through which the infectious principle or virus may find an entrance in the same way as through an external wound or lesion. Perroncito and Carita claim the possibility of a hereditary transmission, and Callignac and Gibier (U. S.) also are said to have observed cases of hereditary transmission, while the experiments of Renault, Roux, Galtier and others concerning the possibility of a transmission of rabies by the dam to her offspring had negative results. From all this will appear, considering the terrible and absolutely fatal character of rabies, that it would have been wise to destroy the pigs at once. Of course, if all proper precautions can be taken, to raise the eleven pigs would be an experiment of considerable scientific value.



A COMPLETE MACHINE IS BUILT AT THE GREAT M'CORMICK WORKS CHICAGO EVERY 30 SECONDS

BUY THE M'CORMICK RIGHT HAND BINDERS REAPERS MOWERS RAKES CORN BINDERS SHREDDERS HEADERS

CALL ON THE M'CORMICK AGENT

## For All Lame Horses

whether they have spavins, ringbones, splints, curbs, or other forms of bony enlargement, use



**KENDALL'S SPAVIN CURE**

Cures without a blemish as it does not blister. As a liniment for family use, it has no equal. Price \$1, Six for \$5. Ask your druggist for Kendall's Spavin Cure, also "A Treatise on the Horse," the book free, or address

DR. B. J. KENDALL CO., ENOSBURG FALLS, VT.

We Want AGENTS For The ECONOMY HARNESS RIVETER And Other Fast-selling Articles.



50c

IT IS LOADED

The riveter can be used in any position. It rivets anything where a well-clinched rivet serves the purpose. For heavy farm work. Can be carried in the pocket. Agents make \$3 to \$15 a day. Send 50c. for sample, loaded with 60 rivets, and TERMS TO AGENTS. J. D. FOOTE CO., Fredericktown, Ohio.

A GOOD WINDMILL LASTS A LIFETIME

Don't buy a poor one when you can buy the



IMPERIAL

with patent internal gear and malleable iron frame. Write MAST, FOOS & CO., 24 River St., Springfield, Ohio



**THE GRANGE**

Conducted by MRS. MARY E. LEE, New Plymouth, Ohio

**BUSINESS TRAINING**

**A** PROPOS of banks let us urge every farmer, no matter how small his savings, to keep a bank account. It is a splendid training in accuracy, this dealing with business men. The very atmosphere of a bank to a small investor suggests caution, reserve and clear, logical reasoning. I know of no better gift a parent can give a child than to teach him the value of money—how to use it and how to be businesslike in the daily transactions of life.

I have watched the career of a great many college students. I have seen them denying themselves the actual comforts of life, while, by injudicious handling of money, they lost more than would have supplied them with the comforts of which they so much stood in need. Many had never had any money to spend in childhood, save now and then a penny. A fond parent, with more of the spirit of gratifying the child's desires than of instilling into his easily molded mind business instincts, immediately suggests that he buy candy with it, or contribute it to one of the innumerable schemes for getting money for some mission or other. Thus he was taught to spend, not to acquire. When by dint of hard work or by teaching a little money was earned, the student unpractised in its use sees it slip through his fingers, scarcely knowing how or where it went. One fact he is conscious of—his tuition is paid to the end of the term, but his money for board and room is a minus quantity. Too well does he understand the algebraic sign -.

The same is true of many who are left to look out for themselves, or with small savings. They are spent, or some unscrupulous person makes way with the inheritance. While one condemns the fraud, the one with so many agencies at work to teach him how to care for himself, but fails to make use of them, comes in for his full share of denunciation and condemnation. Common sense says, "You had the opportunity to learn; you neglected it. Suffer the penalty." And stern Nemesis, that arbiter of human justice, stands by and confirms the sentence of common sense.

Politeness compels people to pity the unfortunate to his face, but as a compensation laugh at him the moment his back is turned. "It's too bad, Smith, the way you have been treated," says the polite friend. But when he meets his next neighbor he says, "Smith was a fool for trusting that fellow; maybe he'll learn a lesson by this." Don't place too high a value on sympathy. It doesn't pay taxes or debts, or buy land.

Familiarize yourself with the business terms used in the daily transactions of life. Keep accurate accounts of all you buy and sell. Keep an individual account of each crop and the labor expended on it, and of each animal you own. This is always practicable on a small farm where only a few head of each kind of stock are kept. Rid yourself of the unprofitable animals. Find where expenses on farm crops can be cut down. Get into some particular line of farming and push it for all it is worth, improving your methods all the time. Always carry a pencil and note-book. It is a great deal easier to sit down under an apple-tree and figure than to toil the long, hot day through. A few hours of accurate figuring will save many days of labor, and increase the profits as well.

How much business sense are you displaying in the conduct of church affairs? Are your schools paying a good per cent on the investment? If farmers, who are the custodians of the business affairs of rural churches and schools, would use business sense in the transaction of the business connected therewith the saving all along the line would be enormous, and better schools and churches would result. And it would not begin by cutting down the teachers' or preachers' salaries, either.

Would not this question of business training be a splendid one for the grange? Again and again our executive committee is confronted with the refusal of business men to deal directly with farmers because of their inability to transact business with accuracy. And shall I say that some farmers are not always strictly honest in their dealings with the companies? Let us remember that there is nothing in any line of work that counts so much as absolute, unvarying integrity; honesty with self, honesty with others.

Arrange a business course of study in your grange. It may not be feasible to have

a business teacher, but it is feasible and possible to get a banker or a successful business man in some of our county-seat towns to lecture before your grange. Give him to understand that he is not expected to deal in rhetorical phrases. Tell him that you want him to explain, as simply and as plainly as possible, some of the principles of business, define technical terms used in business life, and to answer questions the members ask. He will differ very much from the usual banker if he refuses to do so. He will readily see the advantages to the bank and its patrons if the latter understand business matters.

I have before me as I write a valuable little manual, replete from cover to cover with terse, practical, accurate suggestions that every farmer should be familiar with. It is entitled "Small Talks About Business," and is written by A. E. Rice, a practical banker. It is one of those books that every grange should own and use until familiar with its contents. Every farmer's family would be wise to own one, too. B. B. Comegys, in his "Tour Around My Library," has several interesting chapters on business matters. This is a somewhat higher-priced book than Rice's work, and may be obtained through the traveling library.

**A WISE(?) MAN**

Several years ago I went into a strange neighborhood to organize a grange. At one house that I visited a neighbor was calling. I stated my mission and presented as well as I could the objects of our order. The caller looked very wise. He belonged to that class of low-browed people of limited brain capacity who have just sense enough to assume an expression of gravity that simulates fairly well an aspect of wisdom. His countenance had that cast at that moment. He went through the various gymnastic performances peculiar to his class, and delivered his sage opinion.

"No, I don't believe we will go in the grange," said he. "We've been taken in so many times that we're not going to be fooled again. Three years ago we bought a company horse. About the same time a lightning-rod agent worked me for about \$150. Then I bought a lot of apple-trees at fifty cents apiece that turned out to be the Ben Davis. Another agent got \$200 out of me. No, sir, I am not going to take up with anything new. I'll wait till I find out more about it, then maybe if it don't fall through with I will join it."

The last sentence was uttered with a sort of condescending air. How I rejoiced that I had presented the matter conservatively. Had I laid it before him with ornate flourishes and glowing promises of fictitious gains he would have bitten at once. And what a member he would have been for a new grange anxiously struggling to make a success.

Since then our wise man has had a few more turns with the sleek agent, and has lost several hundred dollars more. His neighbors, better informed, meeting every two weeks in their grange meetings, discuss the various propositions made by agents, and by thus bringing the light of public opinion to bear on each matter have been able to save themselves from being swindled. Moreover, they have under consideration now the erection of a canning-factory to handle the great quantities of fruit they raise. We feel confident that they will not entertain any proposition that holds out brilliant inducements or promises one hundred per cent dividends.

Our wise man is rapidly losing the patrimony bequeathed him. His greedy nature, veined with petty dishonesty, coupled with his lack of judgment, will cost him his all. It is from such men that the organization of a grange will meet opposition. Fortunate it will be if the promoters will count such opposition at its true worth, and be thankful that such men do not get into the fold.

**FRAUD**

Now that the farmers have more money to spend, and prospects are good for profitable prices, agents galore swarm the country—book-agents, fruit-agents, machinery-agents of all kinds, promoters and sharks. It will be wise to let all the "opportunities of a lifetime" slip. Books which agents say can be purchased only through local agents may almost invariably be gotten at any of the large department stores for about one fourth the agents' prices. Usually the book is not one of any great value, and is dependent on the enthusiasm of the agent for its sale. Often three hundred or more pages are devoted to a life that history would devote ten lines to. As for machinery, the

reliable makes that stand the test of time are widely advertised in the agricultural papers.

Of the many more or less shady propositions by which the investor is to reap enormous profits, the only thing to do is to let them alone. Remember that there are millions of dollars seeking investment in anything that will pay; that the declining rate of interest indicates that capital is compelled to be satisfied with small profits; and if safe these "rare opportunities" would be snapped up by eager investors whose business it is to watch for opportunities. A very safe rule to follow is to always consult your banker on any question of investment that you know nothing of and which promises fabulous returns. Do you feel a reticence about speaking to him, fearing ridicule? It is your inward monitor warning you. Heed its warnings. Of course, this presupposes that you have an account with a bank of known integrity, at the head of which are conservative men of business ability.

**PARLIAMENTARY DRILL**

The person who is not a skilled parliamentarian is at the mercy of one who understands the intricacies of parliamentary law. No matter how just may be the cause of the opposition, if he does not know how to skilfully parry the thrusts of his opponent, and meet point with point, he is at the mercy of his adversary. In these days when farmers are so vitally interested in matters of public importance it behooves them to make use of every means to increase their influence. How often do we hear men say, apologetically, "I am so ignorant of these things I didn't know what to do when John Smith took the stand he did. I know I was right, but I didn't know how to head him off." Ignorance of the law does not mitigate the severity of the penalty attached for violation of that law.

That one is ignorant of parliamentary usage is not a valid excuse for non-performance of duty. The opportunities for being informed are so many, and one's efficiency is so increased by such knowledge, that one is to be condemned for remaining in ignorance. Besides, there are few things that will lend so much zest to a grange meeting, providing a judicious master is in the chair, as a lively parliamentary drill. It quickens the intellect and aids in the habit of thinking rapidly, concisely and logically when on your feet. Make use of the parliamentary drill in your grange.

**A LIVE GRANGE A GOOD ADVERTISEMENT**

We are in receipt of a letter from a reader in Mississippi, whose name, if mentioned, would call to the minds of older Patrons the name of a past national master of our order, a man much beloved for his good works as well as for his stalwart services in behalf of the farmer. The young man in several places in his letter insists that he wants to buy near a good, live grange. "I always loved the grange, and I want to get where it is." He is right. A neighborhood with the intelligence to maintain a wide-awake grange, the good sense to live amicably and peaceably together, is certainly a desirable place to live in. A live grange indicates an enthusiastic and progressive people. Those outside the order appreciate this fact. "I would not want to locate where the people were not able to maintain a good grange," said a business man who wanted to retire to a farm to spend the rest of his life. "I believe it essential to a happy, progressive people."

**A CANDID VIEW**

We are in receipt of a most excellent lecture delivered by Judge Henry M. Huggins, of Hillsboro, Ohio, at a grange picnic, and published as a serial in the "Ohio Farmer." So many requests have been sent in to Judge Huggins to have this valuable lecture printed for general distribution that he has done so. Judge Huggins is one of the ablest men in our order. He writes vigorously and with a perfect understanding of his subject and a keen insight into the times and its needs.

**NEW GRANGES**

Secretary Trimble reports new granges organized from January 1, 1900, to March 31, 1900, as follows:

California.....	2	New Hampshire.....	1
Colorado.....	2	New Jersey.....	2
Connecticut.....	1	New York.....	2
Indiana.....	8	Ohio.....	8
Maine.....	1	Pennsylvania.....	13
Massachusetts.....	1	Vermont.....	4
Michigan.....	36	Wisconsin.....	1
Total.....	83		

# BOYS

## We Set You Up in Business

We want boys for Agents in every town, to sell

### THE SATURDAY EVENING POST

(Of Philadelphia)

We will furnish you with ten copies the first week FREE OF CHARGE; you can then send us the wholesale price for as many as you find you can sell for the next week.



A handsomely printed and illustrated magazine, published weekly at 5 Cts. the Copy.

You can find many people who will be glad to patronize a bright boy, and will agree to buy of you every week if you deliver it regularly at the house, store or office.

Remember that THE SATURDAY EVENING POST is 171 years old; the oldest paper in the United States, established 1728 by Benjamin Franklin, and has the best writers of the world contributing to its columns. So popular that a hundred thousand new subscribers were added to its list the past year.

Address  
The Curtis Publishing Company  
Philadelphia, Pa.

## BULL-STRONG

Seven styles. Any height desired. Made of Colled Spring Steel Wire, galvanized. The coil makes it self-regulating. It's

### CHICKEN-TIGHT

Our Prices will surprise you. We sell direct to the farmer at lowest wholesale

**Anti-Trust Prices** as we belong to no Combination or Trust. Catalogue and prices free for the asking.

COILED SPRING FENCE CO., Box 18 Winchester, Indiana.

## The ROCKER WASHER

WARRANTED to do the family washing, 100 PICES IN 1 HOUR. No need for washboard; no wear on clothing. Write for special prices and description.

200000 in Use

ROCKER WASHER CO. Clinton St., Ft. Wayne, Ind.

Liberal inducements to live agents.

## GOOD WHEELS

MAKE A GOOD WAGON. Unless a wagon has good wheels it is useless.

**THE ELECTRIC STEEL WHEELS** are good wheels and they make a wagon last indefinitely. They are made high or low, any width of tire, to fit any skeln. They can't get loose, rot or break down. They last always. Catalog free.

Electric Wheel Co., Box 96, Quincy, Ills.

## SEE AND WONDER AUTOMATIC CREAM SEPARATOR

Simple; easy to operate; durable; saves half the labor. Butter-making simplified. More and better butter. Farmers' and Agents' Gold Mine. Price \$2.50; worth \$100. Send stamp for particulars. Agents wanted. Automatic Cream Separator Co., Quincy, Ill.

## THE ABC of BEE CULTURE.

The only cyclopaedia on bees. 466 pages and 406 illustrations. Every phase of the subject fully treated by experts. Price \$1.20. Circulars and sample copy of our semi-monthly magazine, **Gleanings in Bee Culture**, free if you mention this paper.

THE A. I. ROOT COMPANY, Medina, O.

## SPRAY PUMPS

Save your fruit and make you money. "THE DAISY" is 15 years old and 200,000 in use. Has every improvement—rubber hose, perfect nozzles and valves. No. 1, tin, \$1.50; No. 2, iron, \$2; No. 3, all brass, \$4. We pay express. Agents wanted. Catalogue free.

W. M. Johnston & Co., Box 1, Canton, O.

## Fence Machine

That weaves 60 to 100 rods per day out of barb, cable, crimped, coiled or smooth wire. Machines Guaranteed. Catalogue Free. Hooper Boy Fence Co., Indianapolis, Ind. Dept. 23

## GINSENG WE ARE HEADQUARTERS FOR Seed & Plants

All the latest instructions about it; its value; what used for and how to grow it. This valuable information FREE for a stamp.

AMERICAN GINSENG GARDENS, ROSE HILL, New York.

## CONSULTING ENGINEERS

in mechanical, electrical, hydraulic, chemical and civil engineering. Avoid excessive fees by writing for advice to Stevens & Tyler, 325 W. 34th St., New York City.

**For Sale** by the owner, FOUR IMPROVED FARMS adjoining; two sets of buildings; fine climate; one hundred and twenty two acres each.

Address H. A. Beyer, Louise, Wharton Co., Texas.



## BAD HABITS



THESE bad habits of which I am going to talk are not moral, but physical habits, and yet who shall say there is not some connection between the two? Children, especially if they are growing rapidly, are apt to fall into the habit of sliding down in their chairs when sitting, in fact, sitting about half on their spine, with their spinal column more in the form of a bow than a column. It is said that this continued strain on one side of the spinal column, with the corresponding compression of the other side, will cause some nervous difficulties and affections of the brain, besides the appearance of deformity. I have in mind now one boy who was growing very fast and had contracted this habit of sitting in school. He was troubled with frequent attacks of dizziness, faintness, nausea and headache; his mother feared some heart trouble. After a year or two he was sent to a school where he had military drill, and especial attention was paid to both standing and sitting erect. After a few months you would hardly have known the boy. He became as straight as an arrow and all his headaches, dizziness, etc., disappeared.

Parents and teachers cannot be too careful in watching to prevent or to correct bad habits of standing or sitting. These are frequently caused by the child being tired, hence he should not be kept too long in one position. I know one mother who, when she noticed a child sliding down in his chair when reading or studying, would have him lie down on a couch or the floor with face down and his shoulders supported by his arms, his book lying on the floor. This would rest his back, throw the shoulders back and strengthen the muscles. An erect, graceful carriage is very much to be desired, and it can hardly be acquired in later life if no attention has been paid to it in childhood.

Little girls often become stooped and round-shouldered or one-sided from too much baby-tending. If a little girl must carry a baby very much she should be taught to frequently shift it from one arm to the other and to guard against stooping. It would be better if the baby could be carried on the back, as a squaw carries her papoose.

Watch the little girls when they are practising on the piano, that they do not sit in an ungraceful manner, and do not urge them to practise long at one time or the back will become tired, and in trying to rest they will get into some bad position. To me there is nothing more beautiful in the world than a healthy, happy, graceful young girl, and it grieves me to see one falling into awkward habits of carriage.

Children sometimes get a habit of holding the mouth partly open. Besides giving the face an unpleasant appearance this habit is injurious. The mouth was not made for breathing, and diseases of the throat, bronchial tubes and lungs are invited by this faulty manner of breathing. This habit is often caused by a cold in the head, by which the air-passages are obstructed, but attention should be given to it at once not only to prevent chronic catarrh if possible, but the formation of a bad habit.

Children, especially nervous ones, frequently form the habit of biting the finger-nails, and once formed this is one of the hardest habits to overcome. Besides deforming the fingers it is an unclean, injurious habit, and should be checked at its first appearance. It is usually a nervous, fretful, unhappy child who bites its finger-nails, and when the habit is noticed the general health should be looked after. Sometimes little girls get nervous over their lessons and begin to bite their finger-nails when studying, and they sometimes learn it from a companion. Whatever the cause, try to nip the habit in the bud.

The tone of the voice and manner of speaking are almost entirely habit, and yet very little attention is paid in schools or homes to the child's speaking voice. There is no reason why a child should not be taught to speak in an agreeable, cultivated tone instead of high, coarse, nasal, guttural, peevish or drawing tones. Parents and teachers can teach a pleasant, refined tone of voice better by example than in any other way. A teacher of little children should speak to them in clear, distinct but gentle tones, and never in a harsh, scolding voice. If I had the power to prevent, no person with unpleasant habits of voice should ever teach little children. I would make it one of the requirements of the primary teacher espe-

cially that she should have a clear enunciation, with a mild, agreeable tone of voice.

Not long ago I met a young lady who, by her tone of voice, enunciation and manner of speaking, reminded me forcibly of one I had known twenty years ago. In talking with her I found that she had in her childhood been a pupil for several years of my former acquaintance. This accounted for what had before seemed strange, and I wondered upon how many girls this same unpleasant tone and manner had been impressed.

MAIDA McL.

### "PRESERVE THE COMPLEXION"

So great has been the interest of the FARM AND FIRESIDE readers of the household department in a former article under the above caption that a second chapter has seemed imperative. A number of letters have been received by the writer so filled with questions as to make it impossible to give to each inquirer the explicit information in every case desired.

That the desire to remain youthful in appearance was at birth and by birthright implanted in the human feminine heart is everywhere evident. Women at sixty have been known to say that it was a very great trial indeed to have grown old and seamed of countenance. No one will deny that deep wrinkles are disfiguring, and a shriveled skin of parchment hue unsightly. But if no care has been given all through life to the preservation of the skin it must of necessity fast lose its freshness and rosininess and elasticity of youth, and the ravages of time and negligence will leave their impress indelibly by the time that old age has really come.

Care of the complexion all through one's life will bring one to old age fair of skin and unseamed and almost un-wrinkled. If the soil or food materials provided by Nature to and for the skin are continually removed by soaps and water there comes a time when Nature's resources exhausted can no longer furnish the building materials so ruthlessly destroyed and wasted, and the result must be waste of the tissues and skin starvation. Hence the wrinkles, redness and coarseness of skin textures and other unsightly features that follow en train as it ages.

In all letters received since the issuance of my first talk concerning the preservation of the complexion one of the leading questions has been, "How shall I massage the face after home-treatment methods?"

Some have wanted a book pertaining to the question. The writer has not owned such a book. The information I am in possession of has come through reading, observation, gathering of items from a dermatologist, and in the putting together of this, that and everything gleanable; and carrying information into practical effect, have been able to become encouragingly proficient in the art of home-applied massage treatment.

Water is the most successful builder and encourager of wrinkles, hence the less water used upon the face and neck the better. This I am learning more forcefully all the time. An occasional thorough bath for the face with soap and water seems necessary; in truth, is necessary. And yet women possessing the clearest complexions and the softest skin declare loudest against water for the face at any and all times. A preparation that I have found is used in the place of soap and water. The face is coated over with the preparation and left to do its work of opening and cleansing the pores of the skin for some ten or fifteen minutes, when with a soft old piece of cloth it is wiped off and the face and neck rubbed thoroughly and briskly. The appearance of the cloth after such using is astonishing to those who considered themselves well cared for in lines of perfect cleanliness. The nature of the article in question is to open the pores and cleanse them of every impurity and to furnish a natural food for the im-

poverished skin to feed upon. A starved, ill-nourished skin means a "muddy complexion," or, in other words, "a poor one."

A gentle patting and pinching of the face and neck flesh tends to soften the set or drawn lines that are forming fast into wrinkles, and if persisted in will erase them. There is apparently a diversity of opinion as to whether the rubbing or massaging of lines shall be done by rubbing in the direction of the lines or across them. I practise both methods. The massage-roller is of great benefit and lessens the laboriousness of the work. The silver roller called an electric roller has been found beneficial. A massage-roller or set of rollers can be invested in that is more effective, better liked and less expensive. The object of the face-roller is to keep the flesh of the face and neck firm, in a healthy condition and to remove and to prevent wrinkles. It does its work well and satisfactorily. Another roller is for the purpose of reducing superfluous body flesh, reducing the size of the abdomen and hips and giving to the entire physical being tone, strength and firmness of flesh rather than allowing the body to take on and retain a superabundance of fat which is so unsightly and undesirable.

The same processes, with a little difference, will put flesh upon bodies that are thus lacking physical perfectness; for massage treatment can be made to bind or to loosen flesh. It can be made to make flesh or to cause parts to waste or diminish, as in the matter of reducing the abdomen and hips. Women especially are prone by Nature to put on abdominal fat, and nothing is more annoying to a sensitive, proud woman than obesity or a surplus of avoirdupois.



PINEAPPLE STAR

(See description on page 12 of March 1st issue)

A great deal of massage treatment causes waste, hence a daily massage treatment morning and evening for a few moments, or a space of time embracing from ten to twenty minutes, will cause quite rapid reduction of fat and make the flesh firm, and the system of circulation and digestion will improve under such treatment as would little be imagined or believed until tested.

Moderate rubbing or use of the rollers tones up the disused tissues, causes a circulation of blood to wasted parts, and plumpness results from the treatment. One does not require accomplished or professing masseurs. Every woman may be a masseur unto herself. It requires a little time and patience and daily persistence to accomplish the utmost of possible good from massage. Yet only a little time need be given and yet most beneficial results be soon evidenced. A physician of authority says, "Let any lady morning and evening when at her toilet pass her open palm, and especially the tips of the fingers, from the center outward over her forehead for ten or fifteen minutes. She will soon remove the wrinkles from her brow unless she is making them faster through the day than she can remove them at those times."

Between lines and wrinkles there is truly a so-called dividing-line. The lines of deep thought and of study give an individuality and expression to the countenance. These

lines are usually most noticeable between the eyes. Why should we seek to entirely obliterate them, even if we could? For a facial appearance of intellectuality is preferable by far to the expressionless and wrinkleless countenance often met with. Such a face grows monotonous.

But even the lines between the eyes of studious and deep-thinking people may be moderated becomingly. Too deep they grow to a look of sternness. Massage treatment softens. And the network of fine wrinkles that gather about the eyes at the corners and surrounding them and about the mouth may by massage and proper feeding of the skin tissues be softened, removed and effectually kept at bay.

The general bath goes far toward keeping the youthful appearance so much desired. One inquirer wishes to know how much time she should devote to the bath. I would answer that a bath with the flesh-brush and soap and water for the body once in every twenty-four hours is not too often. A hot-water bath should be followed by a dash of cold water. This sets the blood in circulation, closes the pores of the skin temporarily, and thus prevents taking cold. But the usual bath should be in tepid or cold water, followed by a vigorous rubbing until dry. If then the massage-roller is applied to the body much good results from the use of it in every instance. Such treatment in massage and bathing redounds to the great benefit of the complexion as well; for in all that tends to build up the entire system the complexion comes in for a share of improvement.

One inquirer wishes that I tell her if dill-water is good for the complexion; if it is perfectly harmless; if it can be used in place of rose-water, and if dill-water and glycerin in equal parts will not make a good lotion for the face.

Of these things the writer has no personal knowledge. Rose-water has been used with glycerin to an extent, but not with entire satisfaction. It was simply used before something better was known and adopted. To many skins glycerin is as poison. It is irritating, not healing. To other skins glycerin is helpful in a sense. The skin of all persons requires an oil to counterbalance the continual washing away of the oils furnished by Nature's methods. The skin of the young will endure such impoverishing for a time and without seeming injury. But the day of retribution comes inevitably, just as does the once fruitful soil become impoverished by continued cropping without returning to the soil a natural soil-food, through which it may find sustenance and strength, and eventually gives back but disappointment for hope.

A woman hopes to remain beautiful in complexion. But she awakens in time to find her hope turned to disappointment, wrinkles coming and

an appearance of premature age gathering about her brow. A wise and proud woman seeks redress for the complexion she has almost ruined and destroyed. It is as natural as to breathe the breath of life.

NEDELLA HAMPTON.

### SOME GOOD RECEIPTS

**CORN-MEAL MUFFINS.**—Take two cupfuls of meal, one cupful of flour, two eggs, one heaping tablespoonful of shortening, or if melted use three spoonfuls (pork-dripping preferred), two tablespoonfuls of sugar, two teaspoonfuls of soda and one teaspoonful of salt. Put all the ingredients but the shortening in your mixing-pan; make it very hot. Add buttermilk to the meal, etc., to make quite a soft batter, then add the hot shortening, and bake quickly.

**CAPITAL EGG-SOUP.**—For one quart of sweet milk take six hard-boiled eggs; shell them and cut them each in four slices cross-wise, lay them in a deep dish, and dust with a little salt and pepper; when the milk is at the boiling-point add two level tablespoonfuls of flour thinned with cream, let boil up, add a lump of butter half the size of an egg, salt and pepper to taste, and pour over the eggs. This is nice for supper. A cupful of minced codfish added is also very nice.

AUNT CHLOE.



## ONLY A SONG

Love says not much, but says it, oh, so well!

We cannot tell

What is the meaning of its secret spell.

Its charm divine

Is like the murmur of the sounding shell

Heard in the pauses of the ocean's swell,

In beauty's oft-recurring parallel.

Its feeling fine,

Artless of rule, yet more than rules of art

Unconscious pierces, probes, with inward smart,

The lover's breast, the patriot's swelling heart.

Its music fine

Is such that if the singer break his song

And stop the very spheres seem all a-wrong;

We bid him take his lute and sweet and strong

Renew his strain.

Oh, singer, sing once more the old refrain,

And echo faint its burden still prolong

In memory's chain!

And lest it perish, being only song,

Sing it again,

Again, again!

—Spectator.

## LITTLE INVALIDS

TEACH the precious little invalids the wisdom you have learned from life's stern battles, that "God put us just where we are." There is a divine purpose in everything that befalls us. As Longfellow has so beautifully sung in his "Ladder of St. Augustine," these prosaic, worldly hindrances may be made rounds in the ladder toward higher things.

Cheerfulness is more a matter of will-power than of temperament; it may be earnestly and successfully cultivated. The best way is to remember that neither our trials nor our pain need be borne but "a day at a time." This one little day alone is ours.

She was a wise mother who taught her small invalid son always to "brace up" before father came home in the twilight.

Think of others.

Fresh air and sunshine are among the greatest benefactors of the human race. Accustom the invalid to plenty of fresh air even though he is confined within four walls; the child should then be carefully protected with blankets. Never allow the temperature of the room to be over sixty-eight degrees. The sunniest room the house affords should be devoted to the invalid, and thoroughly aired at least twice a day.

Let the child feel that his room is his very own. When the invalid prefers a certain color endeavor to gratify it. Neatness should reign supreme. Rugs are preferable to a carpet. An easy couch, to which the invalid can be gently moved for a welcome change, will prove very beneficial. Pillows of various sizes, with washable covers, are desirable. A screen is very useful here. Keep the medicine out of sight.

The best of all furnishings is the atmosphere of love.

"Books we know

Are a substantial world both pure and good,

Round which with tendrils strong as flesh and blood

Our pastimes and our happiness can grow."

The mission of the mother as well as that of the teacher "is not so much to impart knowledge as to stimulate a love for its pursuit." Another writer graphically says, "Books wind into the heart." A love for good reading is, next to a patient spirit, the greatest blessing an invalid can possess.

When the invalid has a hobby let her study that. Music often has a very restful influence. Pictures which teach a lesson are a wise choice. There are many beautiful religious subjects. Raphael's "Madonna and Child" is a blessing in a home. The popular picture of the Stuart baby is very lovable. Engravings of Rosa Bonheur's horses and Lanseer's noted dogs are admirably adapted to childish needs. Occasionally change the arrangement of the pictures in the room.

Cheery flowers in a window are a comfort to both the inmates and the strangers within thy gates.

One little girl derived much pleasure from this "flower game." She is a rose for one day, a lily the next, while on the third she represents a fair chrysanthemum; the correct variety of paper flowers decorates her room each day. The red rose says, "Be sweet;" the lily says, "Be pure;" the hardy, brave chrysanthemum says, "Be patient and endure."

Another invalid, a young lad, has several plants which he calls his family—the tall, graceful Kentia palm is the dignified, stately grandfather; the hardy, sturdy zealanica is the father; a happy, cheery-faced geranium the mother, while a pure white and a soft pink hyacinth just blossoming are the two children.

A beautiful moral lesson may be taught by the flowers, that just as we carefully watch and cherish every new leaf and sign

of improvement in the plants God watches over his children and is pleased when they grow nobly, doing their best.

It is absolutely necessary that the little invalids should eat wholesome, nourishing food. Bread made of entire wheat is most earnestly advised because of its wonderfully nutritious qualities. Pie, cake and all rich foods should be strictly prohibited. Bread and butter, milk, oatmeal, potatoes, rice, eggs and meat are suitable.

Meals served at regular hours and no lunches between should be the rule.

Serve just the amount of water allowed in a small glass.

Use the prettiest dishes and the daintiest linen your purse will allow; instinctively the invalid will endeavor to live up "to her nice dinner."

More bread and butter will be eaten if made in the form of attractive sandwiches. One clever mother has three shapes—heart, diamond and crescent. Beef-tea may be taken through a straw or tube.

Occasionally an interesting story will overcome the efforts of a poor appetite.

A certain mother who has three small sons calls them the little "soldiers," and trains them accordingly. They are taught that whether well or ill, "soldiers"—the genuine article, Uncle Sam's men—never complain of their "rations."

Soft woolen underwear should be worn by delicate children all the year. Never allow a child to go to sleep cold. Use hot-water bags and more clothing rather than a higher temperature.

Any novel game will be welcome here. In the "telegram game" each word must begin with the successive letter in the one word chosen. Example—Regardless. Regiment eager go. Arthur remains delirious. Lester equally serious symptoms.

This "food game" besides being instructive is a good appetizer. "How many articles of food begin with A?" Apples, asparagus, artichokes. "How many with B?" Butter, bread, biscuit, beef, beans, bacon, bananas. Continue by using other letters. The little pocket-dictionaries are easy for feeble hands to hold.

The boys will enjoy "flags of the world." Circus pictures furnish great sport. The shops offer innumerable toys.

A miniature dining-table, table-cloths napkins and china will attract the small maiden. Scrap-books bring much pleasure both in the making, and afterward in the reading.

Tell stories and act them. These may include fairy-stories, tales from Greek mythology, Kipling's "Jungle Tales," plays of



Shakespeare, etc. Pitch a tent in the nursery with a blanket; here have the small maiden gracefully pose as "Lalla Rookh," while you may take the part of the humble minstrel. Learn something of the customs of Persia. Cultivate the child's imagination.

On Sunday "think of what God has done for you the past week." "He has given you many pleasant hours, many comforts." Read the Bible stories.

One plucky little invalid is successfully cultivating a talent for cheerfulness. He is "the great human magnifying-glass" (his own expression), and shows a reflection of all the kindness done to him. Brave Teddy!

Learning poems and reciting them is a wonderful comfort. One containing these

words, "We thank thee, O my sire, that things are no worse," is a favorite with a small friend of the writer. Another which brought patience is:

"Every day is a fresh beginning;

Every morning is a world made new."

ADELE K. JOHNSON.

## BATTENBERG WORK

APRON IN BATTENBERG.—The top of the apron can be of any of the dainty Swiss materials, and finished at the belt with a

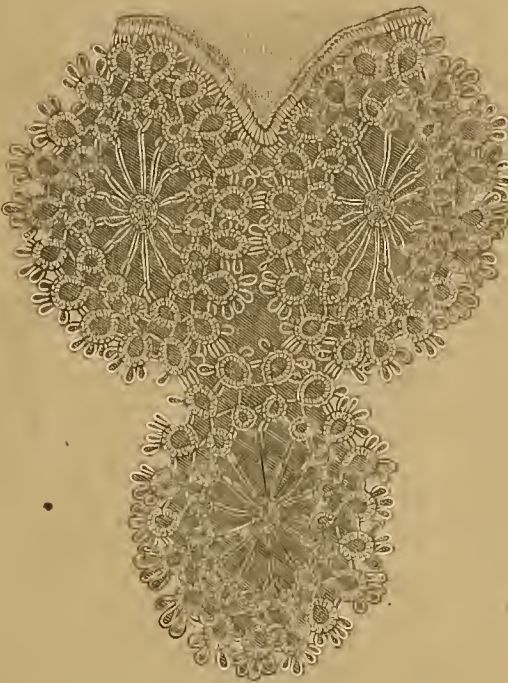

ribbon. The lower part can be of Battenberg, using the coarsest braid, either in white or ecru.

TATTED END FOR TIE.—The tie should be made of fine Brussels net or very fine French lawn; if of the latter hemstitch the sides. The wheels need no explanation, as they are of the plain insertion fastened in a ring, the center put in with a needle and extra thread, and finished with a spider-web in the center. They are then button-hole-stitched to the tie. B. K.

## FROM STRAWBERRIES

To a vast majority the good old way of serving this earliest and finest of our small fruits cannot be improved upon, but sometimes the housewife wishes to try her skill in concocting new dainties from the luscious berry.

STRAWBERRY TARTS.—Bake a number of small pastry-shells, filling in with clean rags or dried beans to keep them in shape. When cold pile up with freshly hulled and washed strawberries, heap whipped cream over the top, and serve with powdered sugar.

STRAWBERRY DUMPLINGS.—Make a rich biscuit-dough, roll out and cut into squares, heap with berries, pinch the dough well up around them, place in a greased pan, pour in barely enough water to cover the bottom of the pan, bake a delicate brown, and serve with cream and sugar.

STRAWBERRY CAKE.—Bake three sheets of sponge-cake; then whip a pint of thick cream, make very sweet, flavor with vanilla and pour on each layer; place strawberries on top of the cream, and put together. Cake, cream and fruit must be cold.

STRAWBERRY TAPIOCA.—Wash one cupful of tapioca and put to soak over night. Next morning add a pint of boiling water and cook slowly until the tapioca is clear. Sweeten to taste, stir in a quart of berries, pour in the dish in which they are to be served, and set away to cool. Use sugar and cream or boiled custard, as preferred.

STRAWBERRY FRITTERS.—Make a batter as for pancakes, only with the addition of a little sugar, stir in the berries, fry in hot fat, and dust thickly with powdered sugar. MARY M. WILLARD.

## WHAT ONE IS USED TO

The tenacity with which persons often cling to things and customs solely because they are used to them found amusing illustration in an Austrian city, where the inhabitants had become so habituated to stale oysters—being unable to obtain fresh ones—that when the latter were finally put upon the market they frankly declared that they didn't like the "new kind." Parents often reprove their children for being "taken with newfangled things" without appre-

ciating the fact that if every member of the human race were like themselves all progress would come to a standstill. There is no old age so much to be dreaded as the variety that is unpliant, is set in its way, that looks aghast at innovations, that ceases to be interested in the new things—this state is simply mental ossification. If Mother Nature herself weren't ever-changing, making every new day and night different, bending her energies to the whims, desires and aims of all the scientific conjurers who strive to improve upon her or change her types, life would soon become intolerably monotonous and uninteresting. So let us welcome the "new kind." M. W. F.

## APPETIZING SPRING SAUCES

That good fish and meat sauces properly used are sure to improve the dishes they accompany goes without saying, but never are they so highly appreciated as during the enervating weather of spring, when the appetite often needs coaxing. The recipes here given will be found wholesome and appetizing, as they are easily made and inexpensive.

TOMATO SAUCE WITH ROAST LAMB.—Make a brown sauce of two tablespoonfuls of fat from the roasting-pan, one rounding tablespoonful of flour and one and one half cupful of boiling water. Stir constantly until it thickens and boils smooth. Add one half teaspoonful each of salt and sugar and three tablespoonfuls of tomato catchup; stir well, bring to the boiling-point, and then serve.

HORSE-RADISH SAUCE.—Cook two slices of onion in two tablespoonfuls of butter until it yellows; remove the onion, add one tablespoonful of flour, and stir smooth; add one cupful of rich milk, one teaspoonful of sugar, one half teaspoonful of salt and a dusting of pepper, and stir constantly until it thickens and boils smooth. Stir two tablespoonfuls of lemon-juice with four tablespoonfuls of freshly grated horse-radish, add to the boiling sauce, and stir well, but do not boil. Serve hot with broiled or roasted beef or fried, broiled or baked fish.

SORREL SAUCE.—Wash and chop fine one half cupful of sorrel, and saute (fry) in two tablespoonfuls of butter; add salt, a dash of cayenne and one cupful of boiling water; when it boils add the well-beaten yolks of two eggs, stir thoroughly, and serve at once with veal cutlets or roast veal.

MINT SAUCE.—Put four tablespoonfuls of young, freshly chopped mint in a saucepan with one tablespoonful of sugar, a hint of nutmeg and one half cupful of strong vinegar. As soon as thoroughly heated remove from the fire, and serve cold with lamb.

CREAM SAUCE.—To one half cupful of mayonnaise dressing to which a little mustard was added add two tablespoonfuls of freshly grated horse-radish and one half cupful of cream beaten very stiff. Have all the ingredients very cold and mix just before serving. Delicious with cold baked or broiled fish and with cold beef or mutton.

RADISH SAUCE.—Fry three tablespoonfuls of sliced radish in an equal amount of butter for ten minutes; remove the radish, add one half teaspoonful each of sugar and salt, a dash of cayenne and one spoonful of flour; stir smooth, add one cupful of white stock, and stir constantly until it boils smooth. Add the chopped yolks of two hard-boiled eggs, stir well, and serve with boiled cod or other fish. KATHERINE B. JOHNSON.

## EARACHE

It is no unusual thing for the children to develop severe earache, one of the most painful of minor ailments. Two excellent and almost instantaneous remedies for this trouble are ether and oil of mullen. Ether is inexpensive and there is practically no danger in using it, as the patient cannot be overcome by it unless air is excluded from the lungs. To administer it for earache a little cotton batting is placed in the bowl of a clean tobacco-pipe, and one or two drops of ether put upon the cotton. The stem of the pipe is put at the orifice of the patient's ear, and the operator blows through the bowl, thus sending the fumes of the ether into the ear. The volatile ether practically refrigerates the congested membranes, and as its action passes off the acute pain is relieved as though by magic. The mullen-oil has exactly the opposite action, it gives the sensation of warmth, and gives immediate relief. One or two drops of oil are dropped into the ear, and the outer ear closed with cotton. This oil is obtained from mullen-flowers; it is not very well known, and comparatively expensive.—Rural New-Yorker.

[HOUSEHOLD CONCLUDED ON PAGE 17]



## A FAIR FIGHT

By Mattie Dyer Britts

## CHAPTER I.

Now, Virgie, you surely are not going on those dirty cars in that gray dress?"

"Why not, Aunt Maggie?" asks Virgie, shaking out her stylish skirt. "It is not a long trip from Ashland to Sioux City. I'll not hurt the dress; if I do papa will get me a new one."

"Well, you are an extravagant puss, that's all! But I suppose you'll have your own way; you generally do in this house."

"Maybe. But it isn't often a very bad way, is it?" said Virginia, laughing. "Here, kiss me good-by, Auntie; Joe will have the road-wagon round directly."

Miss Maggie reached up to kiss her niece, for she was a short, plump personage, and Virgie inclined to be tall, as were all the Van Gillens. As the good little woman gave the kiss she drew a doleful sigh and said, "Lord, I wish you wasn't going at all, I do!"

"But why, Aunt Maggie? You said the same thing at dinner, you know. Why don't you want me to go to see Sue, when we have not met for over a year?"

"It isn't Sue, child; she's as nice a girl as ever lived. It's because—well, I just know something is going to happen if you go. I'm solemnly sure of it; something awful, too."

Virginia laughed a merry, free-hearted laugh—just such a laugh as nobody in the world can give but a happy, healthy Western girl—and answered, "Aunt Maggie, you are a precious old goosie! There will not a thing happen except a lovely time, and I'll be home by the last of next week."

"Well, anyhow, I wish your father was going with you."

"Papa can't leave the store. There, Joe's coming; don't let the haggage-man forget the small telescope, and I do hope to goodness he will get here in time for the train. Ah, here he comes now! Good-by, good-by, and don't fret your dear old head about Virgie, for she's all right!"

She tripped down the steps, took her seat in the dapper little road-wagon, which was the pride of her father's heart, and was speedily driven to the station to take the cars for Omaha. Arriving there, she left the train for a half-hour's wait; and in passing let us say that when the white palaces of the Trans-Mississippi Exposition shall have fulfilled their purpose and vanished like the tents of an Arah caravan, Omaha will still have one enduring monument of gray pressed brick, Bedford limestone and Denver granite to mark the year of 1898, in its palatial depot.

In the large, elegant waiting-room for ladies (where we shall meet her again before our story ends) Virgie spent a pleasant thirty minutes, then took her seat in the train for Council Bluffs and Sioux City, at which latter place she was to visit an old school chum by the name of Sue Winston.

That she met a warm welcome and had a delightful visit no one who knows the people of Iowa and Nebraska need be told, but we must not linger upon its details just now. She had a letter from Aunt Maggie toward the end of the week, in which the good lady, after giving the household items which would interest Virgie, said, "Your pa's well, but he's all fretted out with business matters, and I'll be glad when you get back to straighten him out. I don't mean that he is having any trouble at his own store, but you see he's had all the trade of the East End, and now there's a young fellow coming here to set up a dry-goods store, and they say he's going to rent the Willard Block right across from your pa's, and sell cheap, and so Jason is afraid it will make him lose trade. You know he's always been determined not to let any other dry-goods man get a hold in this end of town, but I reckon he'll have to stand it if one takes a notion to come."

"Yes, I rather think he will, the dear old goosie!" said Virgie, smiling, as she folded the letter. "Papa has made money enough, anyhow, and there is no use of his working so hard at the age of sixty. I'm going to tell him so when I get home, and he shall not worry over that young chap, no matter where he sets up his store."

When she got ready to answer Aunt Maggie's letter, which she did not do for two or three days, she wrote:

"You tell papa he is not to lose any sleep over the young man who is going into the Willard Block, for the town has plenty of trade for both of them. Send Joe to the station to meet me at the eight-thirty train Sunday night. There is an excursion from Sioux City to Omaha on the river that day, and I shall take the steamer as far as Omaha for the fun of the trip. Possibly Sue may come home with me. I know you will all be glad to see us. Say, Aunt Maggie, in spite of all your fears nothing has happened, so won't I laugh at you good? Your loving old VIRGIE."

Perhaps she would laugh; but Virgie forgot "they laugh best who laugh last," with all the fun on their own side. If before we are through our next chapter some wiseacre wishes to make a remark or two concerning the fate of Sunday excursions in general the present chronicler has nothing to say, unless to quote the immortal Sammy Slick, "facts is facts," and everybody is at liberty to draw their own conclusions.

When Sunday came Sue could not leave home, so the passengers for the stanch steamer White Star saw only one slender girlish figure in a gray suit and a natty sailor-hat come tripping down the gangway to go on board. If more than one

head turned for a second glance at the bright, fresh face and sparkling eyes of the young Nebraska girl it was no wonder; this weary old planet holds few sights more attractive than youth, beauty and happiness, and Virgie Van Gillen could claim all three.

There was evidently to be a crowd that pleasant Sunday morning, and as Virgie, carrying her small telescope in her hand, stepped upon the gangway she was jostled by the rush and pushed so near the edge of the plank that she almost lost her footing, and was in danger of falling when suddenly she felt a strong arm flung around her, and a manly voice said in her ear, "Pardon me, miss! They will push you off. Allow me!"

She looked up quickly and met a pair of dark, magnetic eyes and a smiling, manly face belonging to the young man who held her steady for an instant until she could regain her footing.

"Thank you!" said Virgie, blushing, but smiling a little. "I was very near falling, wasn't I? Thank you very much!"

The stranger's traveling-cap had been in his hand the instant he spoke, and now he bowed courteously, answering:

"Don't mention it, miss. Let me get between you and the edge, please."

"It is hardly worth while now—we are over at last," said Virgie. He bowed again, and they were separated in the crowd as the deck was reached. A smart chambermaid came up, addressing Virgie and some other ladies:

opened to notice an elderly lady standing near and looking about for a seat. In an instant Virgie was on her feet.

"Take this chair, please," she said, in a sweet tone.

The old lady looked at her, but hesitated. "I do not like to take your seat, young lady, though you are very kind to offer it."

"Oh, it isn't a bit of difference to me!" said Virgie. "I am young and can stand easily."

"Then can't we share it, my dear? Perhaps it is wide enough for two."

"Oh, no, no!" said Virgie, laughing. "Just sit down; I really don't mind standing at all. Here, let me draw it a little more in the shade; there, now, please sit down."

"I will, since you are so good. Thank you most heartily."

The old lady sat down, and Virgie stood a moment leaning against the railing. Then she felt a slight movement behind her, and she turned. The dark-eyed stranger stood with a chair at her side.

"Here is a seat, miss, at your service," said he.

"Thank you," said Virgie; and as he placed it for her she sat down just next to the dear old lady.

"I wonder if he will try to talk to me now?" she thought. But the young man at once retired to some distance without taking any advantage of his courtesy.

"He's handsome, and I'm sure he is a gentleman," she went on; and as she gazed out over the sparkling waters she wondered again who he could be. Chancing to look up a moment later she met the gaze of the old lady at her side fixed on her with such intentness that it brought the warm blood to her cheeks. The old lady saw it, and spoke to her at once.

"Pardon me, my dear, for looking at you so steadily. But if you knew—" she stopped for an

care to he thought a listener, and leaned over the guard on the other side of the steamer.

"My name I will give you," said the old lady, and took from her pocket a card upon which Virgie read, "Mrs. Lois Pearson, Atchison, Kansas."

"I have been spending the summer with friends in Iowa and am now on my way home," said Mrs. Pearson, who was, as Virgie judged, a lady of considerable property. "I did intend to return by the railroad, but was tempted by the beauty of the weather to take this route."

"Exactly as I was," put in Virgie.

"I am glad of it now, since it has given me the opportunity of meeting you," went on the old lady. "I do not usually take much to strangers, but something seems to tell me, my dear young lady, that you and I did not meet for nothing."

"Thank you!" answered Virgie, smiling. "I do not usually feel toward entire strangers as I do to you, Mrs. Pearson. It seems as if I had known you a long time."

"Will you tell me a little about yourself then?" asked Mrs. Pearson, gently.

Virgie hesitated only an instant; then, feeling sure that she need not fear to trust that high-bred, kind old face, she told her new friend how her mother had been dead since she was a little girl of twelve, and how nobly her place had been filled by Aunt Maggie Kelly, the mother's sister; how she was her father's only child and chief pet, and what his business was.

"Do you think if I were to send him references from the best people in Atchison and come for you myself that your father would allow you to visit me?" asked Mrs. Pearson, as Virgie finished her simple story. "Now that I have found one so like my own darling daughter I do not like to think that we shall never meet again when we part on the steamer."

"Papa is a sensible man. I believe he would consent to an acquaintance with you," answered Virgie.

"I should invite him to make the journey with us and see for himself how things are. My dear, do you smell smoke? It strikes me that I do."

"Yes, I believe I do. No doubt it is blowing our way from the smoke-stacks of the steamer," said Virgie.

"Perhaps. But I fancy it smells like wood-smoke. There is the first dinner-bell. Shall you make any changes in your dress before dinner, Miss Van Gillen?"

"Yes; as it is Sunday I would rather be a little bit dressed up," said Virgie, rising from her chair. "Have you a state-room, Mrs. Pearson?"

"No; I did not try to secure one for so short a trip."

"Then mine is at your service if you would care to use it."

"Thank you. I cannot change my dress, as my dresses are all in my trunk, which has gone on my rail. But I shall be glad to brush up a trifle and arrange my hair."

"Please come with me then." Virgie offered her arm to her new friend and led the way to her state-room. She took off her waist and bathed her face and hands, as did Mrs. Pearson. Then it occurred to Virgie to put on a black silk skirt which was in her telescope, and she did so, saying:

"I don't feel just right unless I am dressed for Sunday dinner, so I believe I will wear this. It will not hurt it to travel the rest of the way home in it, anyhow."

"Well, for my part I am not often given to Sunday travel," said Mrs. Pearson, "but I broke my rule for once, and am not at all sorry so far."

"Neither am I," answered Virgie, as she fastened her pretty belt-buckle and put the gold buttons in her waist. "Now I am ready, Mrs. Pearson, and the last bell has just rung. Shall we go out to dinner?"

But no dinner was served on the White Star that unlucky Sabbath day, nor ever again. They had barely opened the state-room door when a loud shout was suddenly heard, and there was a rush of people on deck, mingled with hoarse cries and wild screams.

"Oh, what is it?" cried Virgie. "What has happened?"

"I can guess!" said Mrs. Pearson, sinking on a divan. "The smell of smoke did not deceive us. See! It is even darkening the cabin! My dear child, the steamer is on fire!"

"Yes, that's what's the matter!" yelled a man passing by. "The boat's burning up, and it's every feller for himself, and Satan take the hindmost now!"

## CHAPTER II.

"Oh, heavens! what shall we do?" cried Virgie, clasping her hands and gazing into her companion's eyes with a face white with terror.

Mrs. Pearson, too, was deathly pale, and it was almost in a dying voice that she wailed:

"We must die, my dear! Our hour has come! Oh, thank heaven that at least I can go with a face so like my own darling's bending over me! But you, dear, you are so young! Your father will grieve so deeply! Oh, must it be?"

"No! no!" shrieked Virgie, suddenly arousing herself to desperation. "No, we will not die! Come, Mrs. Pearson, come! I will save you just as your Virgie would have done! Come!"

She attempted to draw the old lady from her seat, but at first Mrs. Pearson resisted.

"No, dear girl, no use! Let us go quietly since it must be!"

"But I tell you it must not be! It shall not be! Heaven sent me to save you now, and I will do it unless I die myself! Come; there are the life-preservers! Oh, let us hurry or they will all be gone! Hurry! Hurry! For God's sake, hurry!"

She sprang at the trembling old lady and partly dragged, partly actually carried her to the deck, where crowds of frantic people were pushing each



"COURAGE, BRAVE, NOBLE GIRL; ONE MINUTE LONGER!"

"State-rooms, ladies? We have two or three left."

"Yes, if you please," said Virgie, speaking for herself, with the thought, "I shall want some place to leave my hand-haggage and make some little toilet for dinner."

The maid led her to a state-room near the entrance to the ladies' saloon, and after depositing her small belongings she tidied her hair a trifle, straightened her jaunty hat and went out on deck to enjoy the fresh morning air.

Almost every spot was crowded, but there were still two or three steamer-chairs under the awning at the further end of the deck, and thither Virgie made her way. She was quite conscious in passing down the deck that a pair of dark eyes rested on her, and as she half turned the stranger who had assisted her on board again lifted his cap and bowed. Virgie bowed slightly and walked hastily on to the nearest chair.

"I'll venture he's real nice!" she thought. "But I hope he won't come over and try to talk to me. That would be a little too presuming, even for free-and-easy Nebraska. I wonder who he is and where he came from?"

She did not seem likely to learn, for the young man did not follow her, and though he did once or twice pass her seat, he did not stop or appear to wish to intrude upon her acquaintance.

The deck was soon thronged, but Virgie chanced to see no one she knew, so she sat still, admiring the beautiful bluffs along the river, until she hap-

instant, then went on in tones none too firm, "Let me tell you that you remind me so much of a dear lost daughter that I could not keep my eyes from your face. I did not wish to be rude."

"Oh, I am sure you did not!" said Virgie, warmly, for she was interested in the sweet-faced old lady. "I—I should like to hear about your daughter if it will not pain you to tell me."

"It is both a pleasure and a pain to speak of her, my dear. She died two years ago, and she was all I had left. I have been a widow many years."

"Oh, that was sad! I am so sorry," said Virgie, with ready sympathy.

"It seemed to me nothing but sorrow at the time. I could not understand why one so young and so good should be taken and a tottering old tree like myself be left behind. But I have learned now to think that it was best so."

"Might I ask her name?" said Virgie.

"Certainly. Her name was Virginia Pearson, and she was eighteen when she died."

"Why, how strange! My name is Virginia, and I am nineteen."

"Indeed!"

"Yes; my name is Virginia Van Gillen, and my home is in Ashland, Nebraska." Virgie was won in spite of herself to be frank with the old lady, but neither of them noticed the dark-eyed young man standing so near behind their chairs that he could hear every word, or saw the odd smile that came over his face as he caught Virgie's last speech. He walked away at once, as if he did not



other over in mad efforts to reach the boats that were already being lowered.

Red tongues of flame were rapidly shooting up from the stern of the ill-fated steamer and the clouds of smoke grew denser every moment. The spot was an unfortunate one for the discovery of an accident, for they were just at the wild, barren point a few miles below Onawa, where the river is wide and deep and no chances of rescue from the shore. Their only dependence was the boats of the steamer, and these could not hold all the passengers.

The captain and his crew were hard at work, not striving to check the flames—it was too late for that now—but to endeavor to save the helpless travelers before the fire should reach the engine-room and a terrible explosion follow.

Virgie's first agonized glance, when they stumbled upon the deck, was at the rows of life-preservers hanging ready for use. Thank heaven, a few were yet left! She darted toward the rack, but she could not reach quite high enough. She was making one frantic spring in her desperate need when some one caught her as she fell back, missing her point by only half an inch.

"Let me! I will save you; only trust me, and don't be frightened!" said the manly voice she had heard before that day; and again the dark-eyed stranger was at her side, and before she could speak a word had fastened a belt around her waist.

"The other lady—where is she?" he said, in quick, short tones; and at a motion of Virgie's hand he was beside Mrs. Pearson, half supporting her, fastening a belt around her also.

"Come with me! Don't struggle, but do exactly as I tell you, and you shall be saved!" he cried, eagerly, catching Virgie by her waist and Mrs. Pearson with the other arm, drawing and dragging them to the edge of the steamer, pushing aside the surging crowd as if they were children at play. Even at that awful moment the girl could not help admiring his great strength and courage and feeling a willingness to obey him which surprised her and yet was her only comfort.

He fought their way to the steamer's edge; then leaving them both, he cast a quick look about him and made a dart for a light cot which stood under the awning.

"Here, this will do!" he cried. "Catch hold of it, both of you, and hold fast while I throw it. Jump over with it—jump, quick! Not a moment is to be lost! Jump, I say!"

It was a fearful moment—one neither of those helpless women ever in her after-life forgot—but somehow, they could not have told how, they felt themselves going over the side of the boat, and the next second they were struggling in the water, clinging to the frail cot, which would serve to support them for a short while, aided by the belts they wore.

Choking, struggling, they went up and down, almost struck at one time by the passing of one of the loaded boats, yet escaping with life so far.

"My God!" panted the young man, "this is awful! We can't hold up until the boats come back from shore. I can swim to land with one of you, but the man don't live who could do it with two. Which shall it be?"

He looked into both the pale, wet faces for the choice which his own soul failed him in making.

"Her! her! take her—to her father!" gasped poor Mrs. Pearson. "Save her and let me go to my own!"

"No! no! a thousand times no!" shrieked Virgie. "Don't try to touch me! I will not! I am young and can struggle it out! Save her—if you ever loved your own mother, sir, save her first!" "God bless you both, you noble women!" he panted again. "I will save you both or die with you! Catch your arms around my neck"—to Mrs. Pearson—"and you"—to Virgie—"hold tight to my arm and help yourself as much as you can. We may make it until a boat can reach us. Quick now, before—"

Ah! even before the words had left his lips there was a flash, a dull boom, then a terrible report, as if the guns of all the forts on earth had been fired together, and the ill-fated White Star was in fragments.

Not far away two or three frail boats, laden to the utmost, rocked up and down as if about to be engulfed forever with the wreck, and the poor cot to which our party clung was well nigh dashed from their desperate clutch.

But, wonderful to tell, the force of the explosion had flung Mrs. Pearson directly upon the cot, and she lay there like a dead woman, while Virgie hung on with fierce strength to its end. And their brave preserver, but for whose quick action they would have been upon the steamer to the last—where was he?

As soon as she could clear the rush of water from her mouth and eyes Virgie looked for him. He had just been about to strike out with the two clinging to him—where was he? Ah! he was still near her, but oh, see! a great piece of timber had fallen upon him, and he clung feebly to the little cot, one arm hanging down so limply that Virgie knew what had happened—it was broken, if indeed he was not killed.

She gave one wild scream, and frantically throwing herself further upon the cot she held on with one arm, and with the other hand she tried to hold Mrs. Pearson's head up out of the water. A moment or two of this, then her strength gave way. She shut her eyes and was about to let herself go when once more she heard the voice of the young man trying to say, "Courage, brave, noble girl; one minute longer! A boat is coming—they will take us off—keep up if you can!"

Virgie heard the words, faint and far away as in a dream. She felt herself slipping, but knew that some arm was holding her, and then there was a medley of voices and she did not know anything at all.

When she came to herself she was in a pleasant room and several ladies were standing about. She was lying on a low couch, and raising herself, she passed her hand over her forehead and said, in a bewildered way, "Yes, I remember—we were in the boat. But now where are we?"

"You are in the hotel at Onawa, young lady," answered a kind voice, as a lady came to her side. "The boat picked you up and brought you here, you know."

"Did they?" asked Virgie, feebly, as if she did not certainly remember. "The other lady—is she safe?"

"The old lady, you mean? Yes, she is here, on the bed yonder. Lie still a little and take this drink, then you will be able to go to her. She is all right, only worn out."

Virgie meekly swallowed the warm drink, and asked, as she lay back with a shudder, "The rest? Are they—are any lost?"

"A good many, we fear, miss. It is not sure yet, but they say several went down with the explosion. The captain for one."

"Oh, how awful!" sighed Virgie, feeling very weak and faint again.

"Yes, it was terrible. But do not try to think now; wait until you are a little stronger. You will be all right soon, and we will do the best we can for you. We are drying clothes for all of you as fast as we can."

Virgie remembered some one else just then, and raising herself on the pillow she asked, "Was there a gentleman brought in with us?"

The lady smiled and said, "Dear child, there were a number of gentlemen. One of them has a broken arm."

"Yes, that is the one!" said Virgie, eagerly. "He saved our lives. Is he here?"

"He is at the door, asking for the young lady now," said another lady, coming forward. "Can you see him, miss?"

"Yes, in one minute. I will go into the hall. Let me speak to my friend, please—no, I am able to get up now."

She put them aside, as they would have persuaded her not to try to rise, and went with steps yet trembling to the bed on which lay Mrs. Pearson, her eyes closed, her face very white.

"Dear Mrs. Pearson, it is Virgie," said the girl, bending over her. "Can you speak to me?"

"Yes, dear. It was dreadful, wasn't it?"

"Indeed it was. How are you now? Are you hurt anywhere?"

"No, dear; not hurt, only tired out. But better, thanks to these kind people. Are you all right, dear girl?"

"Oh, yes, I'm all right now! Mrs. Pearson, the gentleman who was so good to us wishes to see me. Shall I tell him anything for you?"

"Yes; my thanks. I can never repay him, but he shall find I will not forget him, nor you either, my own dear. You seem like my own after that baptism of fire and water together. Oh, me!" she sighed, and Virgie, gently laying down the weak hand she held, went to the door and passed out into the long, narrow hall.

The dark-eyed young man stood there rather pale and his right arm in a sling, but he spoke cheerfully.

"I am very glad to see you are recovering from your fright."

"And you!" Virgie's eyes filled with tears and she touched his hurt arm. "I do not even know your name yet," she said, simply, "but I can never live long enough to forget that you got this for my sake."

She held out her hand, and he took it in his left one, holding it firmly as he answered, "I thank God that I was able to be of some little service to you, Miss Van Gillen."

Virgie looked up in sudden surprise, and he smiled at her.

"I heard you tell your name to the old lady on the boat, so I have the advantage, you see. My name is Herbert Begole; my home has been at Grand Island. I disturbed you now to ask if there is any message you would like to send to your—friends?" He hesitated before the last word as if he had been about to say something else, but Virgie quickly answered:

"Oh, yes, yes! The news will go to Ashland and my father will be so worried. I want to send him a message. Will you wait a moment?" She opened the door, brought out a chair and gave it to him.

"Please sit down until I get my telegram ready. Perhaps Mrs. Pearson may wish to send word, too."

She hurried back into the chamber, but Mrs. Pearson had fallen into a sleep of exhaustion, and Virgie did not think it wise to disturb her. "There will be time after she wakes," she said; and then she asked one of the ladies for a pencil and a bit of paper. They were given her. She hastily wrote a few words and turned to go into the hall; then, as a sudden thought struck her, she stopped and flushed deeply. But she went on and gave the slip of paper to Mr. Begole, for so she could now call him.

"This is my message," she said. "Please read it and send it for me. And here, please," she slipped a diamond ring from her small finger, "take this and pay for it. My pocketbook was fastened to my belt; it was washed off in that dreadful jump and I have lost all the money I had. But my father will send me more immediately."

Young Begole smiled, shook his head and gently pushed back the hand that held the ring. "No, Miss Van Gillen, that is not necessary. I have been more fortunate than you, for my pocketbook is safe in my pocket; somewhat wet, it is true, but there is silver enough for all our present needs until you hear from your father. Allow me to be your banker until then."

"I thank you," said Virgie, with some dignity. "I will accept your kindness as far as my tele-

gram is concerned. But please keep the ring until I am out of your debt."

"Ob, no; on no account!" He half handed her the little ring, then drew it back. "On second thought, Miss Van Gillen, if you will permit me to keep the ring until we meet again under happier circumstances I will do so."

"Certainly I permit you. I asked you to keep it."

"Thank you. It is a sacred trust. I will return it to you—some day." He gave her a look which she could not altogether understand, but which was entirely reverent and respectful, even though it made her heart thrill with a new and strange emotion.

"I will send your message at once," he added, and hastily went out of the front door to the telegraph-office across the street. On the way he read the message as she bid him. It ran thus:

ONAWA, IOWA, June 11, 18—

RICHARD VAN GILLEN, Ashland, Neb.

Am all right; not hurt. Telegraph money here. I have lost my purse. Will come home by train immediately.

VIRGIE.

"I thought so!" was the young man's remark, with a little nod of his head as he stepped into the office. "This is interesting, to say the least of it. I wouldn't mind it if it wasn't likely to be a trifle embarrassing on my side before it is ended."

"H-em!" remarked the operator as Mr. Begole handed in Virgie's message. "Then there is a young lady here by the name of Miss Virgie Van Gillen?"

"Yes, sir," answered Begole.

"Well, a telegram has just come in for that name; I was going over to hunt her up. Can you take it?"

"I can."

"Here it is then."

"Any charges?"

"No. All paid."

"All right. I will see that the lady gets it."

Begole went back to the hotel and asked for Virgie. The girl who admitted him left the door of the room open, and said loud enough to be heard on both sides, "Here's that young lady's sweetheart callin' for her ag'in."

Virgie came forward, her face very red. "If you mean me you are mistaken," she said, gently. "The gentleman is only an—" she stopped an instant, for she could scarcely say "an acquaintance," when only a few short hours before she had not known he was in the world, nor after what he had done could she call him a stranger; "only a friend," she did say, and went into the hall still bushing and confused.

His first words proved that he had heard, for he said, with a smile, "Thank you, Miss Van Gillen, for honoring me with the name of 'friend.' I hope I shall not prove a false one, and I have learned to-day that one does not need an acquaintance of years to be a true one. Here is a dispatch which has just come for you."

"Thank you," said Virgie. "Can papa have answered so quickly? No, it is from Sioux City. Oh, from the friend I was visiting! Please wait a minute until I see if it calls for a reply; though," with a glance at him, "I know I have no right to trouble you so much."

"Do not think that for one instant," was his earnest answer. "Prove that you do indeed consider me a friend by allowing me to serve you to any extent possible."

"Thank you. I will do so, Mr. Begole." She opened the telegram and read it:

SIoux CITY, June 11th.

VIRGIE VAN GILLEN, Onawa.

News heard. Hope you are unhurt. Will be with you in three hours.

SUE.

"She is coming here—my friend Miss Winston, of Sioux City," said Virgie. "They have heard the news, and do not know whether I am safe or not. Mr. Begole, if it had not been for you they would not have found me here." She looked up again, the tears filling her eyes, her tones trembling.

"Don't speak of it, Miss Van Gillen. Do you wish a reply sent to your friend?"

"I suppose I ought to send a word or two. She will just have time to get it before she starts. But I hate to—"

"There, don't say 'to trouble me,' please; it is a pleasure. Besides, I have your security, you know!" And he smiled and touched his vest-pocket.

"My ring? Oh, yes! I will just send Sue one line, to say I am all right. Wait a second and I will get some paper."

"You need not take time for that; if you will give me her address and what you wish to say I can send it right from the office."

"Then simply say, 'All safe; waiting here,' and send to Miss Sue Winston, Sioux City, and I shall be greatly obliged to you."

"I will do it instantly." He touched his cap (just purchased from the village store) and left her.

Virgie went back to Mrs. Pearson thinking, "Why, it seems as if I had known him all my life! It's very funny! Though what we have been through is not funny at all!"

[TO BE CONTINUED]

## THE BLACK WALNUT

The great size often reached by this tree, the richness of the dark brown wood, the unique beauty of the grain sometimes found in hurls, knots, feathers, and in the curl of the roots, all conspire to make this the most choice and high-priced of all our native woods.

Twenty-five years ago walnut was extensively used in the manufacture of fine furniture and finishings in this country, but manufacturers adroitly drew attention to the beauty of darkly stained

quartered oak, and the use of the rarer wood has greatly declined. But all this time the search for fine black-walnut logs has gone on systematically, though quietly, the trade attracting little attention, though the volume of lumber handled has been large. Though found to some extent in the Atlantic states from Massachusetts southward, the great source of supply has been the central portion of the Mississippi valley. The walnut is at home in the rich alluvial bottom-lands of the Western streams, and in the stony limestone soils of the hills and mountains and such localities the buyers have left few trees unsurveyed. Throughout eastern Kansas, Missouri and Arkansas, as well as the states along the Ohio and its tributaries, may be seen a few logs at the little stations, a ear or two at that, with carefully hewn sides and painted ends, ready for the market.

If you ask where this market is, you will find that the great bulk of this rare lumber goes to Europe. While we have been led into an enthusiastic admiration for fine oak, stained according to the degree of antiquity it is supposed to represent, our European cousins have been paying fancy prices for the rich black walnut that we have allowed to go "out of fashion."—Berea Quarterly.

## THE BOER WOMEN

BY SANNIE KRUGER  
Grandniece of President Kruger

Boer women are strong. They hunt with their brothers, sitting their horses with superb ease, disdaining a saddle, shooting game, big or little, with unflinching aim. General Joubert's wife can be taken as a type of Boer woman who does not fear the whiz of bullets, ready to risk life that her children may enjoy liberty. In peace or war Mrs. Joubert is always at her husband's side. I have often heard her tell that during the last war she drove sixty miles in a Cape cart accompanied only by a little girl. It was a very dark night and the enemy fringed the way, but the men gallantly fighting at the front were in sore straits for food, and her cart was freighted with a precious load of rusks and bread. So Mrs. Joubert, forgetting the dangers that beset the way, drove on to the starving soldiers.

The women are ready to play any part that necessity demands. Not love of carnage, but devotion to her country, steadies her aim and stills her pity. The Boer woman does not fire upon an individual, but upon the vandal who would drag Freedom, soiled and bleeding, from her high estate.

Now for the Boer girl of the rising generation. The discovery of the rich mines and consequent influx of strangers has naturally broadened her horizon and taken her out of the rigid groove of Boer custom. Her actions are largely governed by her elders, but her ideas are iconoclastic to Boer tradition. She may obey the letter, but not the spirit of the laws. She is bred-in-the-bone religious and industrious, but contact with foreigners has made her more cosmopolitan than her ancestors. The town-bred Boer girl of to-day is given a modern education. She goes to school with the foreign children, learns both English and Dutch, and loses much of the Boer clannishness. Her people frown on Anglo-Boer marriages, but oftentimes the Boer girl braves these prejudices and marries the Englishman of her choice. The best Boer families are connected by one, sometimes two or three ties, owing to intermarrying. The Boer swain who goes a-wooing chooses either Friday or Saturday night to visit the maiden to whom he would pay his addresses. It is understood that these two nights are set apart for "courting" calls, and a visit on either night is practically the equivalent of a proposal.

Many of the Boer girls are highly accomplished, studying music and dancing, with French and German instructors. They are, many of them, very prepossessing, with flashing black eyes and olive complexions. The Boer girl is equally at home in kitchen or drawing-room, and a nervous temperament, kindled by foreign contact, promises to save her from becoming the colossus of fat that is the phlegmatic Boer's fate. The Boer girls wear a short skirt and simple bodice for riding and hunting; for dress occasions they pattern their gowns after the English, choosing rather gayer colors than the English wear.—Harper's Bazar.

## THE ORCHARD LANDS OF LONG AGO

BY JAMES WHITCOMB RILEY

The orchard lands of Long Ago!

O drowsy winds, awake and blow

The snowy blossoms back to me,

And all the buds that used to be;

Blow back along the grassy ways

Of truant feet, and lift the haze

Of happy summer from the trees

That trail their tresses in the seas

Of grain that float and overflow

The orchard lands of Long Ago!

Blow back the melody that slips

In lazy laughter from the lips

That marvel much if any kiss

Is sweeter than the apple's is.

Blow back the twitter of the birds—

The lisp, the titter and the words

Of merriment that found the shine

Of summer-time a glorious wine

That drenched the leaves that loved it so,

In orchard lands of Long Ago!

O memory! alight and sing

Where rosy-bellied Pippins cling,

And Golden Russets glut and gleam,

As in the old Arabian dream

The fruits of that enchanted tree

The glad Aladdin robbed for me!

And drowsy winds, awake and fan

My blood as when it overran

A heart ripe as the apples grow

In orchard lands of Long Ago!



WOULD you rather buy lamp-chimneys, one a week the year round, or one that lasts till some accident breaks it?

Tough glass, Macbeth's "pearl top" or "pearl glass," almost never break from heat, not one in a hundred.

Where can you get it? and what does it cost?

Your dealer knows where and how much. It costs more than common glass; and may be, he thinks tough glass isn't good for his business.

Our "Index" describes all lamps and their proper chimneys. With it you can always order the right size and shape of chimney for any lamp. We mail it FREE to any one who writes for it.

Address MACBETH, Pittsburgh, Pa.

Cream, sugar, flavor, salt and ice,

Then satisfaction in a trice.

Lightning Freezer.



A beautiful child's book in three colors free. Address North Bros. Mfg. Co., Philadelphia, Pa.

### TERRIFF'S PERFECT WASHER



SENT ON TRIAL at wholesale price. If not satisfactory money will be refunded. SOLD under a POSITIVE GUARANTEE to wash as clean as can be done on the washboard, even to the wrist- and neckbands of the most soiled shirt, and with far greater ease. Does not wear out the clothes. Economizes soap, labor and time. AGENTS WANTED. Exclusive territory given. Big money made. For terms and prices Address, Portland Mfg. Co. Box 27, Portland, Mich.

### Reversible LINENE Collars and Cuffs.

Stylish, convenient, economical. Made of fine cloth, finished in pure starch, and exactly resemble fashionable linen goods. No Laundry Work. When soiled discard. Ten collars or five pairs of Cuffs, 25cts. By mail, 30cts. Send 6 cts. in stamps for sample collar or pair of cuffs. Name size and style. REVERSIBLE COLLAR CO., Dept. C, Boston, Mass.

### \$18 to \$35 WEEKLY MEN and WOMEN, and Expenses. At Home or Traveling.

Mr. Smith, of Ind., made \$97.50 first 6 months. Albert Hill, of N. J., \$238 first month. Mr. Muncy, of Texas, \$12.50 last month. Carrie Williams, clerk, \$14 in 6 weeks. Mrs. Hitchcox, \$22, besides housekeeping. Lida Kennedy, \$84.00 while teaching. LET US START YOU—No experience needed. Our agents made over \$47,000.00 last month supplying the enormous demand for our famous Quaker Beth Cabinet, end appointing agents. Wonderful Seller. Everybody buys—business men, families and physicians. No scheme, fraud or fake methods. WRITE TODAY for Our Proposition, New Plan, etc. FREE. Address, World Mfg. Co., 47 World Bldg., Cincinnati, O.

### WHY PAY MONEY FOR A SKIRT when you can get one absolutely FREE

Send us your name and address on a postal end we will send you by return mail full particulars how to obtain a Five Dollar Skirt Absolutely Free. This is a special offer to introduce our skirt quickly. During May we shall send a present to every woman who writes us for particulars and states that she saw our offer in the May 1st Farm and Fireside. Address LA PARISIENNE SKIRT CO., Dept. F, JACKSON, MICH.

**DON'T BE HARD UP \$2,000 a Year Easy.** Gents & Ladies at home or traveling, taking orders, using and selling Prof. Gray's Plating. Watches, Jewelry, Tableware, Bicycles and all metal goods. No experience, heavy plate, modern methods. We do plating, manufacture outfits, all sizes. Only outfit complete, all tools, lathes, materials, etc., ready for work. Gold, Silver and Nickel, also Metal Plating by new dipping process. We teach you the art, furnish secrets and formulas FREE. Write to-day. Testimonials, samples, etc., FREE. B. GRAY & CO., PLATING WORKS, CINCINNATI, O.

**BABY CARRIAGES** Shipped C. O. D. to anyone. Combination Go-Carts. Direct from factory at lowest wholesale prices. Dealers large profits saved. No money in advance. \$18 Carriage, \$9.00 | \$5.00 Carriage, \$3.00 | \$12 " | \$6.00 | GO-CARTS from \$3.00 up. Send for free illustrated catalog and special offer. CASH BUYERS' UNION, 164 West Van Buren St., B-7, Chicago, Ills.

If afflicted with SORE EYES, DR. ISAAC THOMPSON'S EYE WATER

### A NEW USE FOR CARPET-TACKS

Captain Joshua Slocum in his solitary voyage around the world in the sloop Spray found a new and exciting use for carpet-tacks. In the "Century" he thus describes an encounter with the natives of Tierra del Fuego:

"Canoes manned by savages from Fortesque now came in pursuit. The wind falling light they gained on me rapidly till coming within hail, when they ceased paddling, and a bow-legged savage stood up and called to me, 'Yammerschooner, yammerschooner!' which is their begging term. I said, 'No!' Now, I was not for letting them know that I was alone, and so I stepped into the cabin, and passing through the hold came out at the fore scuttle, changing my clothes as I went along. That made two men. Then the piece of hawsprit which I had sawed off at Buenos Ayres and which I had still on board I arranged forward on the lookout, dressed as a seaman, attaching a line by which I could pull it into motion. That made three of us, and we did not want to 'yammerschooner,' but for all that the savages came on faster than before. I saw that, besides four at the paddles in the canoe nearest to me, there were others in the bottom, and they were shifting hands often. At eighty yards I fired a shot across the bow of the nearest canoe, at which they all stopped, but only for a moment. Seeing that they persisted in coming nearer, I fired the next shot so close to the chap who wanted to 'yammerschooner' that he changed his mind quickly enough and bellowed with fear, 'Bueno jo via Isla!' and sitting down in his canoe he rubbed his starboard cathead for some time. I was thinking of a good port captain's advice when I pulled the trigger, and I must have aimed pretty straight. However, a miss was as good as a mile for Mr. 'Black Pedro,' as he it was, and no other, a leader in several bloody massacres.

"He now directed the course of his canoe for the island, and the others followed him. I knew by his Spanish lingo and by his full beard that he was the villain I have named, a renegade mongrel and the worst murderer in Tierra del Fuego. The authorities had been in search of him for two years. . . . At night, March 8th, at anchor in a snug cove at the Turn, every heart-beat counted thanks. Here I pondered on the events of the last few days, and, strangely enough, instead of feeling rested from sitting or lying down I now began to feel jaded and worn, but a hot meal of venison stew soon put me right, so that I could sleep. As drowsiness came on I first sprinkled the deck with the tacks that my old friend Samblich had given me, and then I turned in. I saw to it that not a few of them stood 'business end' up, for when the Spray passed Thieves' bay two canoes had put out and followed in her wake, and there was no disguising the fact any longer that I was alone.

"Now, it is well known that one cannot step on a tack without saying something about it. A pretty good Christian will whistle when he steps on the 'commercial end' of a carpet-tack. A savage will howl and claw the air, and that is just what happened that night about twelve o'clock, while I was asleep in the cabin, where the savages thought they 'had me,' sloop and all. They changed their minds, however, when they stepped on deck, for then they thought that I or somebody else had them. I had no need of a dog. They howled like a pack of hounds. I had hardly use for a gun. They jumped pell-mell, some into their canoes and some into the sea, to cool off, I suppose, and there was a deal of free language over it as they went. I fired at the rascals a salute of several guns when I came on deck, to let them know that I was at home, and then I turned in again, feeling sure that I should not be disturbed any more by people who left in so great a hurry."

### THE PRODUCTION OF GOLD

Of the \$10,000,000,000 of gold produced in the world since the discovery of America more than one half has been found since 1860, and more than one quarter since 1835; or, to put it in other words, one half of the gold mined in the last four hundred years has been produced in the last forty years, and one fourth within fifteen years. The Treasury Bureau of Statistics has made some compilations regarding the gold production of the world in view of the temporary suspension of gold-mining in South Africa and its possible effect upon the gold supply of the world. A casual examination of the figures of annual production shows plainly the very rapid increase during the last half of the closing century. From 1493 to 1600 \$501,640,000 worth of gold was found, the average annual production being \$4,644,815. From 1601 to 1700 \$306,315,000 worth was mined, and from 1701 to 1800 \$1,262,305,000. From 1801 to 1860 \$2,120,444,000 was produced, the average annual output being \$15,745,260. In the decade from 1861 to 1870 the average annual production arose to \$1,126,301,500, the total production being \$1,263,015,000. In the next ten years the production was slightly less, being \$1,150,314,000, and from 1881 to 1890 there was also a considerable decrease, the amount being \$1,000,055,600. From 1891 to 1899 the production increased in a remarkable degree, amounting to no less than \$1,807,971,000, the average annual amount being \$204,773,555. This makes the total production between 1493 and 1899 \$9,833,039,600.

An examination of the amount of gold produced from the mines of the Transvaal and by those of other countries shows that the gold production of the entire world is more than double that from the Transvaal; the latter mines produced \$79,213,952 worth of gold in 1898, while the production in other parts of the world was \$208,214,647, making a grand total of \$287,428,600.—Scientific American.

# FAGGED

What a story of suffering that one word tells. It says: "I am all tired out. It seems to me I can hardly take another step. I haven't a particle of ambition. I can't do half my work, I am weak, nervous, and depressed."

## That's Impure Blood

Now you know what the trouble is, you certainly know the cure,—a perfect Sarsaparilla. "Sarsaparilla" is simply the name of the medicine, for in a perfect Sarsaparilla there are a great many remedies.

What you want is a Sarsaparilla that will make your blood pure, a Sarsaparilla that will make it rich and strong, a Sarsaparilla that is a powerful nerve tonic. You want the strongest and best.

## That's AYER'S

"The only Sarsaparilla made under the personal supervision of three graduates: a graduate in pharmacy, a graduate in chemistry, and a graduate in medicine."

\$1.00 a bottle. All druggists.

"Last July my oldest daughter was taken sick, and by the time she began to mend I was down sick myself from caring for her. I was discouraged, and did not care much whether I lived or died. My husband got me a bottle of Ayer's Sarsaparilla, and its effects were magical. Two bottles of it put me on my feet and made a well woman of me."—JANE M. BROWN, Bentonsport, Iowa, Jan. 19, 1900.

IN REACH OF ALL

## BEST EDUCATION

CHRISTIAN NON-SECTARIAN

NORTHERN advantages in Southern mountain climate, 130 miles from Cincinnati. Reduced railroad rates. College, Music, Academy, Normal, Manual. Incidental fee \$4.50 a term. The great expense in education is board. Go where board is furnished cheaply. No saloons.

Find out about BEREA COLLEGE

Address VICE-PRES. GEO. T. FAIRCHILD, LL.D., Berea, Kentucky

WE HAVE HUNDREDS OF MEN AND WOMEN AT HOME OR TRAVELING MAKING

# \$25.00 a WEEK EASY

And want a reliable Agent in every county where we are not represented, to appoint agents for and sell

## BRADFORD'S 2-MINUTE CHURN

A REVOLUTION IN BUTTER-MAKING! Makes butter from SWEET or SOUR cream. Makes more butter and finer quality than any other process. Makes one gallon as easily as five gallons. No need to keep cream until sour or over ripe. No more broken backs. Saves time, money and labor. Lasts a lifetime. DON'T BUY A CHURN BEFORE SEEING OURS. THE ONLY CHURN in the WORLD that MAKES BUTTER in 2 MINUTES! A chance of a lifetime to make money fast and honestly. One on exhibition will sell 50 more. Everybody buys when they see it work. Agents already started are selling 25 to 50 a week. Write us at once for exclusive agency. You can positively make \$25 to \$50 a week all the year round, without experience. Address, BRADFORD & COMPANY, D2, Cincinnati, O.

### ALL THE STYLE! WE TRUST AGENTS

CYRENO BEAUTY. Shirt Waist Pins.

with 8 sets, 3 Pins in a set, different colors, to match all shades of cloth; sell to your friends for 15 cents a set and get free your choice of Three Beautiful and Costly SOLID GOLD-LAID RINGS, set with large Opal, Twin Garnet or Simulation Diamond. Send name. No money wanted unless Pins are sold. GLOBE GEM CO., Providence, R. I.

HUNTING CASE GENTS & LADIES SIZE

Our Prices ON

## AMERICAN GOLD FILLED WATCHES

Are... the Lowest

Before you buy a watch it will not cost you a cent to see our great bargain. Send your name, post office and express office address, and we will send you by express for examination a handsome WATCH and CHAIN COMPLETE C. O. D. \$4.50

Ladies or gents size, double hunting case beautifully engraved, stem wind and stem set, accurately adjusted, expansion balance, warranted a perfect timekeeper. If you do not consider it equal in appearance to any \$40.00 gold filled watch and chain warranted 20 years do not accept it. If entirely satisfactory pay express agent Our Special Price \$4.50 and express charges and it is yours. Our 20 Year Guarantee sent with each watch. Mention if you wish Ladies or Gents size. DIAMOND JEWELRY CO., Dept. F 50, 225 Dearborn St., CHICAGO, ILL.



TWO hundred bushels of Potatoes remove eighty pounds of "actual" Potash from the soil. One thousand pounds of a fertilizer containing 8% "actual" Potash will supply just the amount needed. If there is a deficiency of Potash, there will be a falling-off in the crop.

We have some valuable books telling about composition, use and value of fertilizers for various crops. They are sent free.

GERMAN KALI WORKS, 93 Nassau St., New York.

AN ACRE OF CORN and its possibilities under the Silage system—being the theme of "A BOOK ON SILAGE" By Prof. F. W. WOLL, of the University of Wisconsin, newly bound into a volume of 195 pages and now being sent out by the SILVER MFG. CO., SALEM, O., is unquestionably the best book yet introduced on the subject. It includes: I—Silage Crops. II—Silos. III—Silage. IV—Feeding of Silage. V—Comparison of Silage and other Feeds. VI—The Silo in Modern Agriculture, and many valuable tables and compounded rations for feeding stock. They are going rapidly. To avoid disinterested inquiries the Price is 10c. color or stamps. SILVER MFG. CO., Salem, Ohio.

SOLID STERLING SILVER JEWELRY FREE TO BOYS AND GIRLS. We are giving away watches, cameras, solid gold rings, sporting goods, musical instruments, and many other valuable premiums to boys and girls for selling twenty of our SILVER ALUMINUM THIMBLES at 10c each; package gold eyed needles given FREE with each thimble. Every lady buys soon as she sees it. NO MONEY REQUIRED—WE TRUST YOU. Send us your name and address and we will send them postpaid with premium list and full instructions, when sold, send us the money and we will send you the present you select. Address, AGENTS SUPPLY CO., 75 to 81 Dearborn St., Dept. 209, CHICAGO, ILL.

TROXEL'S HYGIENIC SHOE VENTILATOR. KEEP YOUR FEET COOL. Can be attached to any shoe, New or Old. Price 50 cents per pair. Easily attached by any shoe-maker. Write for circular, or inquire of your shoe-dealer. H. H. TROXEL & CO., ELYRIA, OHIO.

DR. F. WILHOFTS (ORIGINAL) LADY'S SYRINGE. THE ONLY PERFECT VAGINAL SYRINGE. Its principle of action—the use of INJECTION and SUCTION—assures a thorough cleansing. ALL in one piece of best soft rubber; always ready for instant use. Our illustrated booklet, "Useful Information for Women," free. DR. F. WILHOFT, 555 Mott Ave., New York.

\$1,000 SALARY PER YEAR! Ladies or Gentlemen We have shared the general prosperity of the country, and we now need one or two permanent representatives in each state to look after our interests, manage our agents, and attend to collections. This position involves no canvassing and is a home, fixed weekly salaried position, with all expenses paid, to the right party. It is mainly office work conducted at your own home, with an occasional trip out among the agents. No investment required. Also three salaried vacancies in the traveling department. Enclose references and self-addressed stamped envelope to PROVIDENCE CO., 1 Carlton Bldg., CHICAGO.

A BUSY WIFE Should use a BUSY WIFE WASHER 100 pieces in one hour and no hard work done. That's the record. AGENTS WANTED. Exclusive sale. Write for terms. Lake Erie Mfg. Co. 116 E. 13th St., Erie, Pa.

Brass Band Instruments, Drums, Uniforms, & Supp. Inv. Write for catalog, 45 illustrations. FREE! It gives information for musicians and new bands. LYON & HEALY, 95 Adams St., CHICAGO.

\$83.33 MONTHLY SALARY PAYABLE WEEKLY with EXPENSES Men or Women to represent us in their own state. Your duties to take charge of solicitors and attend to collections. No investment required. Send stamp for application blank. CO-OPERATIVE CO., 395 Star Bldg., Chicago, Ill.

WANTED Reliable men or women to sell our goods to the consumer in communities from 1,000 to 10,000 population; permanent employment at good pay. Address THE GREAT EASTERN COFFEE & TEA CO., 301 South 10th Street, St. Louis, Mo.

FREE THIS BANGLE RING with Initial engraved, warranted to wear three years, to any one sending us 10 cents for our Bargains in Jewelry. Shell Novelty Co., Dept. F. N., 194 Broadway, New York.

GOLDMETER in pocket case for hunting Minerals, Gold and Silver, also Rods and Needles. Circular 2 cents. B. G. STAUFFER, Dept. F. F., Harrisburg, Pa.

A WALTHAM WATCH CHEAP A MAN on the inside will give you confidential wholesale prices. BOX 184, Waltham, Mass.

If afflicted with SORE EYES DR. JACOB HOMPSON'S EYE WATER

We Pay \$18 A WEEK AND EXPENSES to man with rigs to introduce our Poultry Compound. Send stamp. Javelle Mfg. Co., Dept. 58, Parsons, Kan.

"THE NICKEL SPEAKER" 50 cts. A YEAR 5 cts. A COPY. 50 new pieces each month, for all grades. Toledo, Iowa.

ANGELS WHISPER Beautiful Large Picture: colored. Sells quick at 25c. Sample 15c.; 9 for \$1. J. LEE, Omaha Bldg., Chicago.



OUR SUNDAY AFTERNOON

HER PURPOSE

Down the long vistas of the years she gazed With eager eyes, expectant and alert. Somewhere her purpose waited; that great work For which she was created. In her heart Burned the deep longing to achieve, achieve— To lead some glorious effort for reform! To feed poor starving minds with loaves of thought, And hungry hearts with love; to cheer, to aid, To help humanity to nobler heights And purer altitudes. She cared not how Nor through what paths God led her to her work, She was prepared for sacrifice and toil And suffering, so he lit at the last She might attain her purpose. Night and day This thought was dominant; it had shaped her dreams And colored all her actions, and it grew To be a wall, which shut her duty out And hid the hearts of dear ones from her view.

A good man starved for love beside her hearth, And little children wandered from the home. To find their pleasure elsewhere, and to learn Life's mysteries from other lips than hers. She dreamed of leading hosts to happiness The while her own was hungering for her care. She dreamed of fame and glory while dear love Sat in the solitude and pined to death. She waited for her purpose, and knew not It dwelt forever lonely at her side And wept because she would not understand. —Ella Wheeler Wilcox, in New York Journal.

GOOD LITERATURE

BY T. DARLEY ALLEN, B.A.

THE reading of good books," said Isaac Barrow, "what is it but conversing with the wisest men of all ages and countries, who thereby communicate to us their most deliberate thoughts, choicest notions and best inventions couched in good expression and digested in exact method?"

Carlyle said, "The true university is a collection of books," and the person who makes a wise choice as regards the books which he reads, choosing only those from which he can learn something of value, will have no need to lament his lack of a college education. The vast majority of men and women read very little literature upon historical and scientific subjects. A great deal can be learned from the reading of good novels, but only a small percentage of one's reading should be spent upon fiction if the best results are to be attained. If a person will read good books upon history, science, etc., it will not be long before the wisdom of such a course becomes apparent. The man or woman who is determined to succeed will certainly be successful. Carlyle said "that genius is an immense capacity for taking trouble." There are many men whom the world considers exceptionally brilliant, but whose success is due not to any exceptional gifts, but to their determination to succeed. Whoever is determined to possess a liberal education can secure the object of his desire in spite of all difficulties. Of course, it is well if a person can do so to attend college, but the many distinguished men and women who have secured a liberal education outside college walls show that in this age of books an education is not beyond the grasp of the man or woman of even the most limited opportunities.—Boston Ideas.

HARMONY-MAKERS

"There are some lovely people in this great world of ours," says Alice Bertha Dawson, in "Universal Truth," "who remind us of fragrant flowers. Whenever they draw near we are glad, but know not why. They may not possess physical beauty or riches or marvelous intelligence, but their atmosphere is like themselves, pure. They rest us, for they are the embodiment of peace. They inspire us, for they are full of inspiration of the highest order.

"These people are like a quiet lake beside which grow tall and beautiful plants, which, when reflected in the water, make a pleasing picture. There is no jarring, not a ripple on the mirror-like water. The colors of earth and sky harmonize exquisitely. Birds sing a soft lullaby into their ears. The world with its din is only a sweet song. They themselves make harmony.

"You and I meet these veritable soul-flowers every day, but little do we appreciate their worth until they pass away. Some few of us, however, catch a glimmer of their soul life; and later on, when they drift away on that heaven-bound vessel, we feel that what we call death is only transition.

"The perfume of their influence will be wafted to us through the days to come, and we are better men and women for having known them."

Don't Go Blind or Deaf!

But Write DR. COFFEE, Des Moines, Iowa

For his 80-page book, telling all about his mild medicines that absorb Cataracts, White Spots, Blindness and all Eye Inflammation, Deafness and Head Noise, at Home. 13,000 patients cured last year. He can do for you what he did for these people, write to-day. Address 334 Good Block, Des Moines, Iowa.



77 Years Old and Cured of Cataracts on Both Eyes: Too old to permit of an operation for being cured until she learned of Dr. Coffee's new method of curing cataracts—she travels from Aurora, Neb., to Des Moines, and has her sight restored perfectly—can see to read the finest print.

Des Moines, April 12, '99. To Whom It May Concern—This is to certify that I am 77 years old; that I live in Nebraska, in the town of Aurora; that I commenced to lose my sight over one year ago from cataracts on both eyes, and, having a son, R. E. Hammond, living at 1510 24th street, Des Moines, Ia., I decided to visit him last fall and consult an oculist in Des Moines. He took me to Dr. W. O. Coffee, and I went under his treatment for the cure of cataracts by absorption, as I was too old to be operated on. I have carried on this treatment for nearly five months and yesterday he turned me off as perfectly cured. I can see as perfectly as I ever did, can thread a needle without glasses; and I want to say, to any one afflicted with cataracts of the eyes and blindness, that Dr. Coffee's new absorption method does cure them and that his terms are very moderate.

LUCINDA HAMMOND. A Wonderful Cure of Deafness—It Required Thirteen Months—But He is Cured by the Home Treatment: Auburn, Sae Co., Iowa, Jan. 15, 1900.

This is to certify that I am fifty-four years old, that I have lived in Sae Co. thirty years, that I commenced to get deaf and have trouble with my ears twelve years ago, and I have gradually got worse until I could not hear conversation or preaching or a watch tick. No treatment seemed to help me until I wrote to Dr. Coffee, at Des Moines, and began his home treatment. The first three months I did not seem to improve any at all, but, it being my only hope, I stuck to it, and I am thankful to say that my hearing is now almost perfect, my cataract is cured, my rheumatism has all left me, and I seem to be in perfect health. I want to say to everybody that is deaf, if they will stick to Dr. Coffee's treatment he will cure them. Yours respectfully, THOS. GORMAN. (Write quick before Books are all gone.) Mention the Farm and Fireside.

BICYCLES FOR EVERYBODY. NO MONEY IN ADVANCE. Shipped direct to anyone and guaranteed as represented or money refunded. Save agents large profits and get a wheel at rock bottom wholesale price. Our Arlington Model K is the greatest bargain ever offered; in lots of one or more at \$14.85 \$35 "Arlington" \$16.50 \$40 " " \$18.50 \$50 "Oakwood" \$21.50 Good wheels \$12.50, \$11.00 & \$10.00 Stripped Wheels \$7.00 The Arlington & Oakwood are strictly high grade and the best that can be made. Thoroughly tested and fully guaranteed. Over 100,000 riders can testify to their superior quality, style, construction and workmanship. Illustrated catalog free. CASH BUYERS' UNION, 162 W. Van Buren St., B-7, Chicago, Ills.

ASTHMA FREE. If you suffer from any form of Asthma we want to send you free by mail, prepaid, a Bottle of the famous Kola Plant Compound. It is Nature's Sure Botanic Cure for the disease, and we guarantee that it will forever stop all your suffering. We are sending out 50,000 bottles free by mail to sufferers, to prove the wonderful power of this New Discovery, and we will be pleased to send one to you. Send your name and address on postal card. Address, THE KOLA IMPORTING CO., No. 1164 Broadway, New York.

SILVER WATCH FREE! These Watches are Solid Silver, Ladies' or Gents' size, and at retail would cost upwards of \$5. or \$10, but to introduce our Persian Perfumery we will send you this Watch Free if you take advantage of our marvelous offer. If you want one GET THIS OUT quick, write to us without delay. With your letter send us your name & postoffice address and we will send you on assignment, to sell for 5 cents each, 20 cases of Persian Perfumery and our offer. After you receive the beautiful Watch we shall expect you to show it to your friends and call their attention to this advertisement. The Watch is sent Free, by Registered Post, on your complying with our advertisement, and the marvelous offer which we send, and it is Fully Warranted. You will be more than satisfied. Address at once, PERSIAN PERFUMERY CO., 19 Warren St., New York.

SENT FREE Solid GOLD OR SILVER plated Bicycles sent free for LADIES GOLD plated Bicycles with an exquisite jewel. Simply send your name & address & we will send you the pins post money & we will send you the fully engraved & the lock opens front you & will take back all to-day. The MAXWELL CO. anyone for selling 5 sets of our Pins for 25c. each, each pin set simply send your name & address & paid. When sold, send us the Bracket. The chain is beautiful with a dainty little key. We the pins you cannot sell. Write DEPT. 657 St. Louis, Mo.

\$5 BICYCLES CHEAPER THAN EVER from the OLD RELIABLE CO. Great Special Sale. Nearly 3000 Bicycles, every one a BARGAIN. Must be sold. All makes, 2nd h'ds, \$5 and up. Late models new \$11.50 and up. Shipped anywhere on approval. A few more good agents wanted. Big Money. Write to-day for big list and special offers never before approached. BROWN-LEWIS CO. Dept. (J) Chicago, U.S.A.

LADIES I Make Big Wages —AT HOME— and will gladly tell you all about my work. It's very pleasant and will easily pay \$18 weekly. This is no deception. I want no money and will gladly send full particulars to all sending 2c. stamp. MRS. A. H. WIGGINS, Box 20 Benton Harbor, Mich.

BIG COMMISSIONS TO LADY AGENTS Lady agents for McCabe corsets and fine undershirts get generous commissions and make big money because the goods sell on sight—varying styles for different figures—prices within reach of all. Write for particulars. ST. LOUIS CORSET COMPANY, ST. LOUIS, MO. Coe's Eczema Cure \$1 at drugists. 25c. box of us. COE CHEM. CO., Cleveland, O.

Knickerbocker Special

AND South-Western Limited Famous Trains Between

BOSTON, CINCINNATI, NEW YORK, CHICAGO, WASHINGTON, ST. LOUIS,

Big Four Route

AND NEW YORK CENTRAL, BOSTON & ALBANY, CHESAPEAKE & OHIO.

Cafe, Library, Dining and Sleeping Cars. W. J. LYNCH, W. P. DEPPE, Gen. Pass. and Tkt. Agt. Asst. G. P. and T. A. CINCINNATI, OHIO.

NEW BOOKLETS

The Chicago, Milwaukee & St. Paul Railway is issuing a series of booklets regarding points of interest along its lines, and if you are interested in the western country, or contemplating a trip, write Geo. H. HEAFFORD, General Passenger Agent, Chicago, Ill., for the special publication desired, enclosing four cents in stamps for postage for each one.

- No. 1. The Pioneer Limited. No. 2. The Land of Bread and Butter. No. 3. The Fox Lake Country. No. 4. Fishing in the Great North Woods. No. 5. The Lake Superior Country. No. 6. Cape Nome Gold Diggings. No. 8. Summer Days in the Lake Country. No. 9. Summer Homes, 1900. No. 11. The Game of Skat. No. 12. Milwaukee—The Convention City. No. 13. A Farm in the Timber Country. No. 14. Stock Raising in the Sunshine State. No. 15. Hunting and Fishing.

1200 Dollars Given Away

CAN YOU arrange the 18 letters at the left into three names denoting THREE WELL-KNOWN ADMIRALS of the U. S. NAVY during the SPANISH WAR? If you can make out these names you may share in THE DISTRIBUTION OF 1200 DOLLARS WHICH WE ARE GIVING AWAY for doing a little work for us. This you can do in less than one hour of your time. This and other liberal offers are made to introduce one of the very best Boston Story Magazines into every house in the United States and Canada. WE DO NOT WANT ONE CENT OF YOUR MONEY. When you have made out your answer, write it plainly on a postal card and send it to us, and you will hear from us promptly BY RETURN MAIL. It may take considerable study to get the three correct names, BUT STICK TO IT AND TRY AND GET YOUR SHARE OF THE 1200 DOLLARS. A COPY OF A CELEBRATED DOLLAR BOSTON MAGAZINE WILL BE SENT FREE to every one answering this advertisement. Send your answer immediately. Address: THE RIGLEY PUBLISHING COMPANY, 88 and 90 Purchase Street, BOSTON, MASS.

TO THE AMERICAN SUMMERLAND

"The Overland Limited," VIA UNION PACIFIC ONLY THREE NIGHTS BETWEEN CHICAGO AND CALIFORNIA

"The Overland Limited" runs every day in the year and makes many hours quicker time between Missouri River and San Francisco than any other line. Finely equipped with Double Drawing-Room Palace Sleepers, Buffet Smoking and Library Cars, with Barber-Shop and Pleasant Reading-Rooms. Dining-Cars, Meals a-la-carte. Pintsch Light, Steam Heat. For tickets, advertising matter, and full information, call on or address A. G. SHEARMAN, Gen. Agt. Pass. Dept. U. P. R. Co. Room 36, Carew Bldg., Cincinnati, Ohio.

FAT How to Reduce it Mrs. L. Lanier Martin, Penn., writes: "I reduced my weight 11 lbs. in 15 days without any unpleasant effects whatever." Purely vegetable, and harmless as water. Any one can make it at home at little expense. No starving. No sickness. We will mail a box of it and full particulars in a plain sealed package for 4 cents for postage, etc. HALL CHEMICAL CO., Dept. B, St. Louis, Mo.

THE ELECTRICITY from the batteries through your table or hand. Cures Rheumatism, Liver and Kidney Disease, Weak and Lame Back, etc. For advertising purposes we will give ONE DOLLAR FREE to one person in each locality. Address E. J. SNEED & CO., Dept. No. 65, VINELAND, NEW JERSEY.



# AMERICA SAYS SO

## The Entire Country is on the Move

Cascarets Candy Cathartic Did It, and Record a Phenomenal Victory—Five Million Boxes Sold Last Year

From every part of America comes the news that sufferers from constipation have found relief in Cascarets Candy Cathartic, the wonderful modern scientific laxative and intestinal tonic. Cascarets are figuratively and literally in everybody's mouth. Thousands have tried Cascarets with the most pleasant and effective results, and voluntarily testify to their experiences. Here are a few extracts from some of the letters:

"I have been using Cascarets for headache and constipation, and have received great benefit from them." Mrs. M. Gahler, 512 Larrabee Street, Chicago.

"I have been taking Cascarets for over a month, and find them just the thing for constipation." Albert B. Burt, 70 Main Street, Andover, Mass.

"I am using Cascarets, and have never found anything so satisfactory." Mrs. C. W. Durrant, 57 Emerson Street, Buffalo, N. Y.

"I have taken Cascarets, and cheerfully recommend them to all my friends." Mrs. G. J. Gradwell, Frugality, Pa.

"Cascarets are fine for biliousness and malaria, and are so pleasant to take." Mrs. Mary Cummings, Maud, Oklahoma.

"I use Cascarets in my family, and find them all you recommend them to be." E. L. Irvin, Cor. Mead and Railroad, Meadville, Pa.

"You can safely add appendicitis to the list of diseases that Cascarets will benefit or cure." Eunice J. Smith, Rich Valley, Ohio.

"I have used Cascarets; there is nothing better for constipation." Benj. Passage, Knightstown, Ind.

"Cascarets are all right. They have cured me of constipation, and I never expected anything would." Charles H. Nye, Lock Box 205, Cincinnati, Ohio.

"I am so thankful for your Cascarets. They are better than any medicine I ever used." Mrs. M. Rew, Laclede, Iowa.

"I do not hesitate to say that Cascarets is the very best medicine ever placed before the people." Andrew Woodruff, Daysville, N. Y.

"Cascarets are the best cathartic I ever used." Tom Holt, Wellwood, Manitoba.

"I have tried your Cascarets, and I want to tell you they are just splendid." John Wiegminck, Box 961, Allegan, Mich.

We could fill the whole paper with expressions like the above. Thousands of similar recognitions of the merits of Cascarets have been volunteered and prove that this delightful laxative, so pleasant of taste, so mild and yet effective, has secured a firmly established place in the hearts of the people.

Go buy and try Cascarets yourself to-day. All druggists, 10c., 25c., 50c. Booklet and sample free. Address Sterling Remedy Company, Chicago or New York.

This is the CASCARET tablet. Every tablet of the only genuine Cascarets bears the magic letters "CCC." Look at the tablet before you buy, and beware of frauds, imitations and substitutes.

# ALLEN'S FOOT-EASE

## A Powder for the Feet.

### Shake into your Shoes

Allen's Foot-Ease, a powder for the feet. It cures painful, swollen, smarting, nervous feet and instantly takes the sting out of corns and bunions. It's the greatest comfort discovery of the age. Allen's Foot-Ease makes tight-fitting or new shoes feel easy. It is a certain cure for ingrowing nails, sweating, callous and hot, tired, aching feet. We have over 30,000 testimonials. **TRY IT TO-DAY.** Sold by all Druggists and Shoe Stores, 25c. Do not accept imitation. Sent by mail for 25c. in stamps.

**FREE TRIAL PACKAGE** sent by mail. Address **ALLEN S. OLMSTED, Le Roy, N. Y.**

(Mention this paper).

# FREE Musical Parlor Clock

To successfully introduce our Eagle Havana Cigars in every county, reliable persons furnished free a Musical Parlor Clock. The clock is best American, runs eight days with one winding, strikes hours and half hours, has Wined onyx case, with gilt ornaments, etc.

The Musical Box plays automatically and produces charming selections, from operas to popular songs or hymns, and sells as high as \$25.00. To every person sending us 50 cents, and names of six cigar-smokers we will ship, securely packed, our premium offer and a one Eagle Havana Cigars, full size, **EAGLE MFG. CO., 21 John Street, New York.**

# \$14 If You Want to SAVE MONEY

and get the best machine at lowest wholesale price, now is your chance. Buy direct from factory, one profit. All attachments free. 30 days' free trial. **WARRANTED 20 YEARS.**  
\$40.00 Arlington for ..... \$14.00  
\$50.00 Arlington for ..... \$17.00  
\$65.00 Kenwood for ..... \$21.50  
Other Machines at \$9, \$10.50 & \$12  
Illustrated catalog and testimonials free. **CASH BUYERS' UNION, 158-164 W. Van Buren St., B-7, Chicago, Ill.**

**WE SHIP ON BICYCLES \$100 DEPOSIT**  
\$11.75 Buys a Bicycle Complete, Unguaranteed.  
\$16.50 Buys an Up-to-Date Model, Fully guaranteed.  
\$22.50 Buys a Full Racing Bicycle, Model. Shop-worn Bicycles from \$10 up. 24 Hand Wheels from \$5.00 up. We want Agents Everywhere. 64 page catalogues of bicycle parts and repairs FREE. Write for catalogue and see how you can get a BICYCLE FREE by helping us advertise. Address: Dept. A-3, **VICTOR MANUFACTURING CO., 161-167 PLYMOUTH PL., CHICAGO, ILL.**

# CURE SENT FREE To Any Address.

For CATARRH, COLD in the head, HAY FEVER, LA GRIPPE and all diseases of the lungs. **D. WILSON, M. D., 18 Boylston St., Boston, Mass.**



# SMILES

## THE WOMAN WITH THE BROOM

(Written after seeing a farmer's wife cleaning house)

Bowed by the cares of cleaning house she leans Upon her broom and gazes through the dust, A wilderness of wrinkles on her face, And on her head a knob of wispy hair. Who made her slave to sweeping and to soap, A thing that smiles not and that never rests, Staunched in stall, a sister to the cow? Who loosened and made shrill this angled jaw? Who dowered this narrowed chest for blowing up Of sluggish men-folks and their morning fire?

Is this the thing you made a bride and brought To have dominion over hearth and home; To scour the stairs and search the bin for flour, To bear the burden of maternity? Is this the wife they wove who framed our law And pillared a bright land on smiling homes? Down all the stretch of street to the last house There is no shape more angular than hers, More tongued with gabble of her neighbors' deeds, More filled with nerve-ache and rheumatic twinge, More fraught with menace of the frying-pan.

O lords and masters of our happy land! How with this woman will you make account; How answer her shrill question in that hour When whirlwinds of such women shake the polls, Heedless of every precedent and creed, Straight in hysteric haste to right all wrongs? How will it be with cant of politics, With king of trade and legislative boss, With cobwebs of hypocrisy and greed, When she shall take the ballot for her broom And sweep away the dust of centuries?

—Edw. W. Sanborn, in New York Sun.

## MARY AND THE BIKE

Mary had no little bike— Like other kids at school— And so she stole the teacher's out, Which was against the rule. The teacher chased, but 'twas in vain, For she flew along like a fairy, Until the bike shied at a rock And pied itself and Mary.

## EPISODES OF CHILDREN

**A** LITTLE boy, in whose home there are a great many Madonnas, said the other day, "Mama, I can't go anywhere in this house but what God and his mother are looking at me."

Willie, aged four, was out walking with his mother, when a beautiful carriage, in which sat a "chemical blonde," powdered and painted, passed by. "Shouldn't you think," he said, "they would have a prettier lady with such pretty horses?"

Aunt Ella—"Well, Bobbie, I hear it's your birthday to-morrow. Now, what would you like your auntie to give you for a present?"

Bobbie—"Big box o' choc'lates."

Aunt Ella—"Well, what else?"

Bobbie—"Novver big box o' choc'lates."

Aunt Ella—"Oh, but I'm afraid so many choc'lates would be too much for your little tummy. Choose something else."

Bobbie—"Novver tummy."—Punch.

Jimmie, while playing with a little girl friend, kissed her. Her mother, who saw it, laughed, whereupon Jimmie took courage and kissed Rosa again. And again her mother laughed. On going home Jimmie told his mother how he had kissed Rosa twice and how her mother had laughed both times. But his mother said, "You are ten years old now; you are quite too big a boy to be kissing little girls. You must not do it again." Jimmie kept a diary. The next morning his mother found the following entry in it, "I kissed Rosa twice. Her mother saw me and she luffed. Mama scolded me when I told her. This shows there is a difference in wimmen."—Cambridge Chronicle.

## THE DEBTOR'S STRATAGEM

"Yes," said the business man, "I have given up trying to collect that little bill from Bilkins. You see, he is a pretty big fellow, and he used to throw my collectors out."

Friend—"Then why didn't you employ a woman collector? He couldn't do that to a woman."

Business man—"That's what I thought, so I got one and sent her round; but she never came back."

Friend—"Why not?"

Business man—"He married her?"—Spore Moments.

## HER CONDITION

"I next have the pleasure, ladies and gentlemen," said the dime-museum lecturer, with an indicative wave of his hand toward a large glass case, "of calling your attention to the mummy of an Egyptian princess. In her day she was no doubt very beautiful; and although thousands of years have passed since then she—" he winked at a friend in the audience—"is still a well-preserved woman."—Judge

## CHARLESTON-BY-THE-SEA

National Educational Association, Charleston, S. C., July 7th-13th. Low rates Queen and Crescent Route and Southern Railway. Write for free books to W. C. Rinearson, G. P. A., Cincinnati.

# WALTHAM WATCHES

The factory of the Waltham Watch Company is the largest and most complete establishment of the kind in this or any other country.

Waltham Watches are the most accurate pocket time-pieces it is possible to make.

Waltham Watches are for sale by all retail jewelers.

## Watch and Chain FOR ONE DAY'S WORK.



This Cut is 1-2 Actual Size of Watch and Chain.

We send this Nickel-Plated Watch, also a Chain and Charm to Boys and Girls for selling 1 1/2 dozen packages of BLUINE at 10c. each. Send your full address by return mail and we will forward the Blaine, postpaid, and a large Premium List.

No money required. We send the Blaine at our own risk. You go among your neighbors and sell it. Send us the money that you get for it and we send you the Watch, Chain and Charm, prepaid.

This is an American Watch, Nickel-Plated Case, Open Face, Heavy Beveled Crystal. It is Guaranteed to keep Accurate Time, and with Proper Care should last ten years.

BLUINE CO., Box 392 CONCORD JUNCTION, MASS.  
The Old Reliable firm who sell honest goods and give Valuable Premiums.

## Deal with the Makers



When you buy a carriage, buggy or harness. Choose from the biggest stock and fullest assortment, and pay only the cost of making, with but one moderate profit added. Our plan of selling direct from the factory insures satisfaction—your money back if you're dissatisfied with your purchase—and enables you to **save the dealer's profit.**

Our complete illustrated catalogue, showing many styles of high grade vehicles, harness, robes, blankets and horse equipments, with detailed descriptions of each, mailed free. Write for it and learn how cheaply you can buy when the jobber's and dealer's profits are cut off.

**THE COLUMBUS CARRIAGE & HARNESS CO., P. O. Box 772, Columbus, O.**

No. 3084 Buggy. Price \$38.30 with leather quarter top.  
No. 240 Single Strap Buggy Harness. Price \$2.15.

## THIS HIGH-GRADE BUGGY FITTED WITH RICHARD'S LONG DISTANCE AXLE.



Runs 1,000 miles without oiling; Bailey body loops; quick shifting shaft coupler; open rubber head springs; Derby 5th wheel; rubber covered steps; leather covered bows; leather covered whip socket; 13 in. padded dash; 30 in. shaft leathers with round tug leathers; trimming, 18 oz. all wool broadcloth; spring cushion and back, stuffed with hair, top, including back and side curtains, lined with wool cloth. This is an elegant buggy. Guaranteed equal to buggies that retail for \$100. Our price, \$62.10. Single Strap Harness, No. 20175, retails for \$20. Our price, \$10.85.

**WE ISSUE** the largest and most complete Vehicle and Harness book ever printed. The illustrations are very large, showing every vehicle in detail and full description. Our styles are the latest. 68 styles buggies, prices \$32 and up; 50 styles Phaetons and Stanbopes; 55 styles Surreys, \$50 to \$140; 37 styles Road Wagons and Carts; 25 styles Spring Wagons, \$35.25 and up. 250 styles Harness, Saddles, Fly Nets, Lap Robes and Blankets. 160-page Vehicle Catalogue FREE.

**MARVIN SMITH CO., 55-57 59 N. Jefferson St., Z-26 Chicago.**

## 144 PIECE FREE DINNER SET



Full size for family use, beautifully decorated & most artistic design. A rare chance. You can get this handsome dinner set and one dozen fine plated tea spoons for selling our Pills. We mean what we say & will give this beautiful dinner set absolutely free if you comply with the extraordinary offer we send to every person taking advantage of this advertisement. To quickly introduce our Vegetable Pills, a sure cure for constipation, indigestion & torpid liver, if you agree to sell only six boxes of Pills at 25 cts. a box write to-day and we send Pills by mail, when sold send us the money & we send you one dozen plated tea spoons together with our offer of a 144 piece dinner set same day money is received. This is a liberal inducement to every lady in the land & all who received the spoons & dinner set for selling our Pills are delighted.

**AMERICAN MEDICINE COMPANY, DEPT. D, 32 WEST 13th STREET, NEW YORK CITY.**

## WIDE AWAKE WOMEN

everywhere are furnishing their homes without money by distributing a few of our fine soaps, perfumes, extracts and toilet preparations, among their friends and neighbors.

### NO MONEY NEEDED



Free

We send the goods and premiums on 30 days trial and guarantee them. This handsome Couch is only one of our many premiums. You can furnish your home without one cent. Write for our handsome free book of premiums, Watches, Cameras and Bicycles. Write today. **Crofts & Reed, 842-850 Austin Av. Dep. G, Chicago, Ill.**

## NOME CITY, ALASKA

Is twenty-four hundred and fifteen miles from Seattle via ocean, thirty-three hundred and eighteen miles overland. Is said to be the richest gold-field discovered up to this time. The first steamer will leave Seattle on or about May 10, 1900. For full particulars, maps, etc., address Geo. H. Heafford, General Passenger Agent Chicago, Milwaukee & St. Paul Railway, Chicago, Illinois.

## ECZEMA

Facial Blemishes, Tetter, Salt Rheum, Barber's Itch, Scald Head, Ring Worm, Itching Piles, Sore Eyelids, and all Skin diseases promptly cured by Spencer's Ointment. Sent to any address on receipt of 25c. **A. O. PILSON, Pharmacist, 1327 W. Baltimore St., Baltimore, Md.**

## RUPTURE

Sure Cure at home; at a small cost. No operation, pain, danger or detention from work. No return of Rupture or further use for Trusses. A complete, radical cure to all (old or young). Easy to use; thousands cured; book free (sealed). **DR. W. S. RICE, Box F, Adams, N. Y.**

## FAMILY RECORD

A beautiful picture; rich colors; background solid gold. Tremendous seller. Agents delighted. Sample free for 12 cents to pay postage and advertising, nine for \$1, post-paid. **HOME ART PICTURE CO., Chicago, Ill.**

## OPIUM

and Liquor Habit cured in 10 to 20 days. No pain till cured. Write **DR. J. L. STEPHENS CO., Dept. A3, Lebanon, Ohio.**

## Agents Wanted

An Incandescent Light in Your Home; no dynamo required; write quick for territory; great prospects. **W. D. GRAVES ELEC. & MACH. CO., Cleveland, Ohio**

## Cancer

REMOVED ROOT AND BRANCH in 10 days; home treatment; cure guaranteed; a wonderful medicine; no caustic used. Write for booklet free. **SCHWARTZ CANCER CO., Lebanon, Ohio.**

## DO YOU KNOW?

We will mail you our printed matter showing we save you money on vehicles, harness and repairs. We make the goods, you use them. Buy direct and save dealer's profit. If we get your name, you get our prices. Cost you nothing. Write us at once. **HUBBELL & WATERHOUSE CO., ST. LOUIS, MO.**

## BEST CALICO 3/8c. Yard

gingham, 3/8c.; seamless socks, 2 1/2c.; bluing, 1c.; soap, 1c.; store-polish, 2c.; cold ring, 1c.; jeans, yard, 9 1/2c.; spectacles, 3c.; men's jeans pants, 49c.; boy's pants, 14c.; men's \$2.25 shoes, 90c.; men's shirts, 15c.; dippers, 2c.; knives, 3c.; shoe-blacking, 1c.; men's wool socks, 9 1/2c.; box tacks, 1c.; men's fine suits, \$3.95; rice, per pound, 3c.; oatmeal, 2 1/2c.; smoking-tobacco, 3 1/2c. Send for price-list. **C. A. WILLARD CO., Chicago, Illinois.**

## MOUTH-HARP PLAYERS!

Big Money selling The New Harp-o-chord. Harp and Zither combined. 17 inches long. 10 times louder than mouth-harp alone. Easy to learn. Our line Mouth-harp sent for 6 names Harp-players and 14c. postage. Catalogue Free. **HARP-O-CHORD CO., 65 L St., Columbus, O.**

## WANTED AGENTS

in every county to sell "Family Memorials;" good profits and steady work. Address **Campbell & Co., 155 Plum St., Elgin, Ill.**



**OUR AGENTS RIDE IN CARRIAGES**



**More Money can be Made Working for Us than at any other Legitimate Business in America to-day and we furnish HORSELESS CARRIAGE FREE!**

We want immediately responsible, live, wide-awake representatives in each county of every State in the Union to show our line of staple household goods and help advertise them; we offer unparalleled inducements in the way of compensation for services. Our goods are not to be peddled from house to house but orders are taken by showing our handsome large plate book accurately illustrating the goods. No capital is required and you should be able to make at least \$90.00 PER MONTH with little effort on your part as our goods sell themselves. If you prefer to work on a salary you can do so and we will pay according to your ability; we will guarantee to establish you in a life business if you will engage with us at once. In addition to large commissions—more than paid by other concerns—we propose to furnish our representatives, Free of Cost, with a Horseless Carriage; the carriage we propose to furnish is the New England Motor Carriage, Salesrooms, 116 Bedford St., Boston. This carriage has no equal on the world's market, costs \$750.00, weighs about 750 lbs., simple in construction, odorless, and almost noiseless, operated by steam under perfect control, can be run for one cent a mile and by anybody with ease, rate of speed limited only by character of the road. The horseless carriage is designed to revolutionize methods of travel and it should be an added pleasure to be the first owner of one of these wonder vehicles in your locality. Let us hear from you at once before all valuable territory is taken, stating where you desire to work; we want no boys or girls or representatives in large cities. Address: **STANDARD DISTRIBUTING COMPANY, 69 Pearl Street, Boston, Mass.**

**\$1000 for BOYS**



Send ten cents for three months' trial subscription to **THE AMERICAN BOY**. A practical magazine for boys. Departments: Short Stories, Successful Boys, What Boys are doing, Talks on Business, Insurance, Savings Banks, Bookkeeping, etc., Boys as money-makers, The Boy in the office, store, factory, home, church and school, Games and Sport, The Boy's Library, The Boy Journalist, Printer, Collector—(Stamps, coins, curios, etc.), Photographer, Mechanic, Scientist, Orator and Debater, Boys and Animals, Prizes and Puzzles. Interesting, instructive, pure, elevating, inspiring. \$1000 in Cash Prizes and a choice from 300 elegant premiums given for subscribers. The magazine canvasses for itself. You need not show it. The best paper ever issued for boys. References in every city. \$1.00 a year. Trial three mos. sub. for 10c. **SPRAGUE PUBLISHING CO., 136 Maj. Bldg., Detroit, Mich.**

**FREE** To introduce in every home our new patent-applied-for **CHAMPION FIBRE BLUING** we make this grand offer: Sell for us 18 packages Champion Bluing at 10c. each—earn these elegant premiums. Sell on sight **NO MONEY REQUIRED; WE TRUST YOU!** Dinner, Tea, Bureau Sets, Watches, Solid Gold Rings, Cameras, Base Ball or Fishing Outfits, Clock Sets, etc. Choice of 68 others in catalog. Send name and address—we send Bluing free postpaid. When sold send money—we send any present you select. Address, **CHAMPION BLUING CO., 46 State St., Chicago, Ill., Dept. 14.**

**IF NOT! WHY NOT?**

If you do not hold a responsible, high-salaried position, it is because those above you have made a study of their business. We have sent thousands of young men and women to prosperity who have studied between times through our thorough course of **EDUCATION BY MAIL** in Electrical, Mechanical, Steam, Mining and Civil Engineering, Metallurgy, Art, Architecture, Practical Newspaper Work, English Branches, Stenography, Machine Design and Mechanical Drawing. Low price; easy terms. Mention subjects interested in when writing to **THE UNITED CORRESPONDENCE SCHOOLS, 158 5th Ave., New York, for Catalogue 72.**

**SAVES YOUR BACK.** Carpet laying—hardest and most disagreeable work of house-cleaning time—is made the easiest by the **Positive Carpet Stretcher and Tacker.** Works perfectly, stretching the carpet to its place, feeding the tacks and driving them home to stay. Works on wheels—gets into all corners. Price only \$1.75. Circulars and special terms free. Deposit Pearl Button Co., Dept. E. Deposit, N. Y. **Big Money for agents.** Write today.

**\$27.15** Buys the **Best Steel Range** ON EARTH. Handsomely decorated in nickel. A **FINE BAKER.** Guaranteed to bake biscuits in five minutes. Write for circulars. **Columbia Steel Range Co., 550 North Street, KOKOMO, INDIANA.**

**Do-You Suffer With PILES** Send us your name and address, and let us mail you our Booklet—"FACTS," about the **only specific** for the non-surgical treatment of **PILES.** Our Guarantee: We will refund the price paid for this remedy in any case of Piles if it fails to relieve or cure. **MERTANNO PHARMACEUTICAL CO., 422 Scott Street, Covington, Ky., U. S. A.**

**RUPTURE** CURED while you work. You pay \$4 when cured. No cure, no pay. **ALEX. SPEIRS, Box 37, WESTBROOK, MAINE.**

**BED-WETTING** CURED. Sample FREE. Dr. F. E. May, Bloomington, Ill.

**HOUSEHOLD**

[CONTINUED FROM PAGE 11]

**A LIFE**

I saw the little maiden moon—  
She was so shy, so shy,  
She hid herself behind a cloud  
Till all the stars went by;  
As pure as sea-foam was her robe,  
And white as ivory,  
And lily-buds that blow on earth  
Raised timid heads to see.

I saw the moon, the full-grown moon,  
Leap from the ocean's hold,  
And hare her beauty to the sky,  
Fierce, glorious and hold;  
And crimson was her flaunting robe,  
And red as sin, maybe,  
And poppy-buds that blow on earth  
Raised wicked heads to see.

I saw the moon, the dying moon,  
Falter across the sky;  
White-faced she fell before the morn  
That smiled to see her die.  
No wave that kissed her feet of old  
But mocked her misery;  
Only the sere, blown leaves of earth  
Might mourn for such as she.

—Kansas City Independent.

**WEDDING-CAKES**

**RICH BRIDE-CAKE.**—Ingredients are five pounds of sifted flour, three pounds of fresh butter, two pounds of white sugar, five pounds of currants, three ounces of shelled bitter almonds, three fourths of a pound of candied citron, six ounces each of candied orange and lemon peel, one fourth of an ounce of mace, one fourth of an ounce of cloves, seventeen eggs, one gill each of brandy and wine, two nutmegs and a little rose-water. Blanch the almonds in scalding water; pound them one at a time in a mortar, pouring in as you do so the rose-water—a few drops at a time, to prevent the almonds from oiling—to make them lighter and keep them from sinking in a lump to the bottom of the cake. Set away to cool. It is best to prepare almond-paste the day before using. Proceed to work the butter with the hands till it is of the consistency of cream. Add the sugar. Whisk the whites of the eggs to a stiff froth, and add to the butter and sugar. Beat the yolks of the eggs fifteen minutes, and add them with the flour, two teaspoonfuls of baking-powder, grated nutmeg, powdered mace and ground cloves, beating the whole three quarters of an hour. Then proceed to add lightly the almonds and currants, with the thinly sliced peel, and lastly the brandy and wine. Then beat for half an hour. It will take almost three hours to bake this cake. Turn on end to cool, and spread with almond icing when cold.

**WHITE BRIDE-CAKE.**—Take one pound of butter, put it into a basin, and beat with your hand till it is finely creamed; then add one and one fourth pounds of pulverized sugar, and beat together until it is fine and white; then add one pound of sifted flour, give it a stir, and then add the beaten whites of fourteen eggs; continue to beat, and add another pound of flour with a heaping teaspoonful of cream of tartar and fourteen more whites; beat well, mix all, paper a baking-pan around both sides and bottom, and bake in a moderate oven. When cold ice with a white puff-icing made this way: Boil one cupful of granulated sugar in one third of a cupful of water until it strings, then take from the fire. Have ready the whites of two eggs beaten very light, and beat together till cool. While beating add a lump of tartaric acid half the size of a pea, and the icing will puff up and remain very light, but not sticky.

**BLACK CAKE.**—Ten eggs, one pound of butter, one pound of browned flour, one pound of dark-brown sugar, three pounds of raisins, three pounds of currants, one pound of citron shaved very fine, one nutmeg, one cupful of wine and brandy mixed, one teaspoonful of soda and two of cream of tartar. With the hands work the butter and sugar to a cream, beat the eggs separately, and add to the butter and sugar; dredge some flour over the fruit, adding it the last thing. Work the flour, in which has been mixed the soda and cream of tartar, into the mixture gradually, along with the brandy and wine. Stir the mixture very hard, and set immediately into a moderately hot oven. When sure it is done place it on an inverted sieve, to let the steam evaporate; cover lightly with a napkin, and let it cool gradually. When cold ice with a maple-sugar or chocolate icing. **Mrs. W. L. TABOR.**

**"NO PLACE LIKE HOME"**

THE IDEAL OF HAPPINESS FOUND IN FAMILY LIFE

There is no plea which a criminal can ever make which offers so much ground for a lenient sentence as this: "I never had a home."

The gray-haired judge as he hears the plea lets his thoughts float away back to those days when mother kissed him as she tucked him into the bed so white and warm.

"Never had any home!" The counsel for the prosecution thinks of the little folks who'll run to meet him as he shuts the door on the world and crime to bask for the evening in an atmosphere of love.

"Never had any home!" The working-man on the jury thinks of the bright light in



a cottage window growing ever brighter as he quickens his steps to the march-time of his cheery whistle, going home. Court, counsel and jury feel sympathy for the man who never had a home.

The state is founded on the home, and the law regards the wanton breaking up of a home as one of the chief crimes against good order and government.

And yet there is one breaker-up of homes who defies the law. He hushes the shrill, childish voice into whispers. He puts out the light which guides the tired feet homeward. He shuts the piano, and drives boys and girls into the streets for amusement. And the name of that destroyer of homes is **DR. PIERCE'S**. For when we come to see the essential element which makes homes, the leaven which leaveneth the whole lump, we find it in the love of wife and mother. "It's home where the heart is," and the hearts of husband and of child find that the home magnet is the fond wife and faithful mother.

When the health of the wife and mother gives way the home begins to fall into ruin. How can a woman bear the romping of children, the music of the piano, when her nerves are jarred by the least noise? How can the wife smile on the husband when her back aches, her head aches and her whole body is racked with pain?

It is not to be wondered at then that husbands and wives alike have been profuse in praise of Dr. Pierce's Favorite Prescription, which cures womanly ills and restores the wife and mother to her position of homemaker.

**A HUSBAND'S THANKS**

"In answer to your letter I will say my wife commenced to complain twenty years ago," writes Lewis A. Miller, ex-Chief-of-Police, 33 Prospect Street, Weissport, Pa. "We have tried the skill of twelve different doctors. She took gallons of medicine during the time she was ill, until I wrote to you and you told us what to do. She has taken eight bottles of Dr. Pierce's Favorite Prescription and six of the 'Golden Medical Discovery.' She can do her own work now and can walk around again and is quite smart. She is still continuing the use of the medicines, and will do so, for there is nothing better on earth."

Dr. Pierce's Favorite Prescription makes weak women strong and sick women well. That brief phrase expresses the wonderful power of the medicine over womanly diseases. To speak of "weak" women doesn't seem to mean very much. But when we begin to consider the strain and burden laid upon the weak woman we can begin to understand the possibilities of suffering suggested by the word "weak." Her side and back ache, but she must lift heavy weights and stoop and reach in household work until the women who were stretched on the rack of martyrdom can alone compare in suffering with hers. Her head aches, her eyes burn, her nerves quiver, but she must walk the floor with the fretful baby and try to get it to sleep. It is to women such as these, suffering, miserable, bearing the heavy burdens of wifely obligation with womanly fortitude, that Dr. Pierce's Favorite Prescription comes as a Godsend. It makes

them well. It does away with physical ailments which are caused by womanly ills.

**FROM SICK TO WELL**

"I was sick for a long time with female trouble," writes Mrs. Lydia Craft, of Larwood, Linn Co., Oregon, "but paid little attention to it until last winter. I had a mishap and this left me in such a weakened condition. I grew very nervous and despondent. I did not want to see anybody; everything seemed so strange, as though I were in a strange land. I had such a disagreeable feeling in my head; it was not a headache, but a drawing feeling, and the top of my head was hot and painful. I had bearing-down pains, and my back hurt me all the time. I could not do any work at all and could not sleep. I tried some patent medicine, but got no relief. I went to see the best doctor in Lebanon. He said I had inflammation of the inside lining of the uterus. He treated me for a while and I did not see much change. I wrote to Dr. Pierce, and in due time received an encouraging letter, advising me to take his 'Favorite Prescription' and 'Golden Medical Discovery.' I did so, and am very glad to say it helped me steadily. I could see that I was gaining. When I wrote to you I weighed eighty-seven pounds, now weigh ninety-nine. I can eat anything I want to, my appetite is good, I can work all day and not feel tired at night. I have no more bearing-down pains. My head does not trouble me any more at all, and I feel better than I have for three years."

"Favorite Prescription" regulates the periods, dries weakening drains, heals inflammation and ulceration and cures female weakness.

No medicine can compare with it for the comfort and security it gives in the months before the baby comes. It nourishes and tranquilizes the nerves, promotes a healthy appetite and induces refreshing sleep. It makes the baby's advent practically painless. It is superior to all so-called "tonics" for nursing mother, increasing the secretions which form the natural nourishment of the healthy child.

**A HAPPY WOMAN**

Mrs. Axel Kjer, of Gordonville, Cape Girardeau Co., Mo., writes: "When I look at my little boy I feel it my duty to write you. Perhaps some one will see my testimony and be led to use your 'Favorite Prescription' and be blessed in the same way. This is my fifth child, and the only one who came to maturity, the others having died from lack of nourishment—so the doctor said. This time I just thought I would try your 'Prescription.' I took nine bottles, and to my surprise it carried me through and gave us as fine a little boy as ever was. Weighed ten and one half pounds. He is now five months old, has never been sick a day, and is so strong that everybody who sees him wonders at him. He is so playful and holds himself up so well."

Sick and weak women are invited to consult Dr. Pierce by letter, free. All correspondence is read in private, and answered in private, and held in sacred confidence. Write freely, therefore, to Dr. R. V. Pierce, Buffalo, N. Y.

There is no alcohol in "Favorite Prescription," and it is entirely free from opium, cocaine and all other narcotics.

Dealers who are eager to make the little more profit paid by less meritorious articles sometimes endeavor to substitute another medicine as "just as good" as "Favorite Prescription." Insist on the medicine which has made half a million women well and strong, Dr. Pierce's Favorite Prescription.

**THERE'S NO PLACE LIKE HOME**

for a copy of Dr. Pierce's Common Sense Medical Adviser, sent free on receipt of stamps to pay cost of mailing only. This great work contains 1,008 large pages. It is a guide to health and happiness. It is full of wisdom for the wife and mother, for the husband and the family. Send 21 one-cent stamps for the book in paper covers, or if handsome cloth binding is desired send 31 one-cent stamps—expense of mailing only, to Dr. R. V. Pierce, Buffalo, N. Y.

**THE QUEEN AND CRESCENT**

Route makes low rates to Charleston, S. C., for the great meeting of the National Educational Association July 7th-13th. Write W. C. Rinearson, G.P.A., Cincinnati, for particulars.

**DO YOU KNOW** of any worthy person in your neighborhood who would like an opportunity to earn some money either by working all or part of the time? If so, please send us the name and address, or ask the party to write us at once for particulars. Address **THE CROWELL & KIRKPATRICK CO., Circulation Department, Springfield, Ohio**



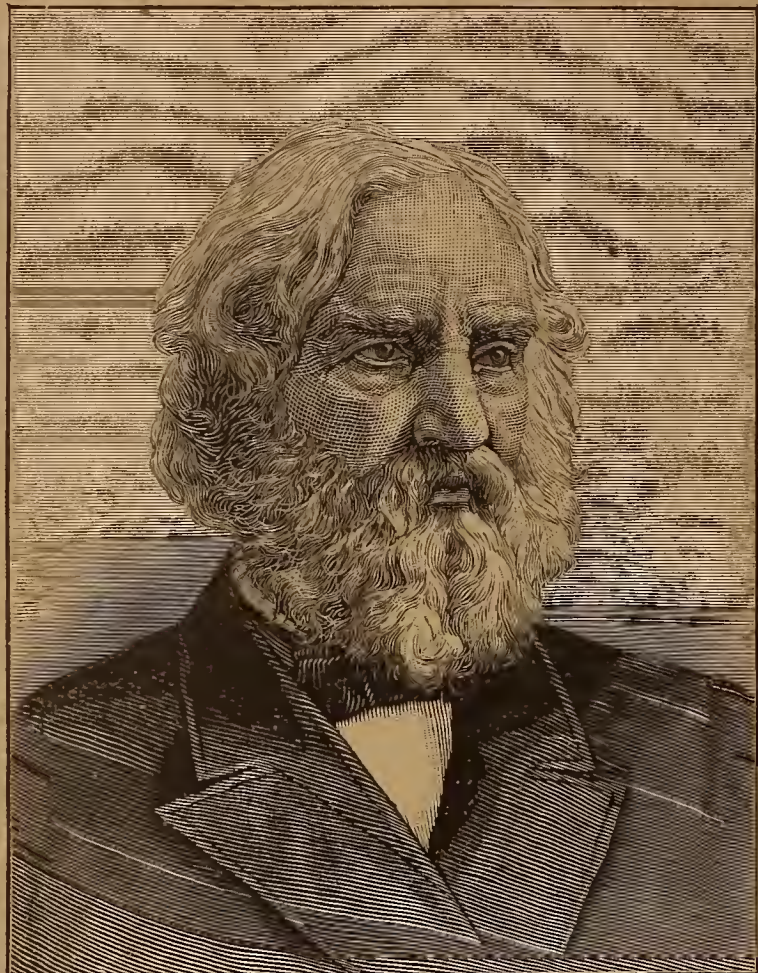

HENRY WADSWORTH LONGFELLOW  
(One of the illustrations from "Gems From the Poets")

# Gems From the Poets

The Cream of Poetical Literature

A Delightful Book Containing 400 Poems and Pictures

IT IS FULLY ILLUSTRATED

**T**HIS work contains a discriminating collection of what may be considered the Gems from all the poets. Only representative productions are used, and as a result we have the very highest class of literature. It contains choice poems for all moods, all occasions, and will surely please every one. It is the *only* low-priced collection of poems *fully* illustrated. In fact, it is more completely illustrated than any similar work ever issued, either high-priced or low-priced; each page has one or more illustrations. The designing and engraving of the illustrations alone cost at least \$20,000. The pages are large—7¾ by 10 inches—and the book is large in proportion. In addition to the large list of poems by the masters of literature and their superb illustrations the work contains a very interesting collection of portraits and biographies of popular poets.

### PARTIAL LIST OF AUTHORS REPRESENTED

WHITTIER	SCHILLER	MILTON	HOOD
BRYANT	SHAKSPERE	ANGELO	SHELLEY
RILEY	LONGFELLOW	POPE	WORDSWORTH
SWINBURNE	POE	SCOTT	HOWE
DANTE	BURNS	LOWELL	BYRON
TENNYSON	MOORE	HOLLAND	EMERSON

We feel free in saying that no better value has ever been offered by any paper than this great work, and Farm and Fireside one year, for 40 cents.

We Will Send This Book, and the Farm and Fireside One Year, for **40 Cents**

(When this offer is accepted the club-raiser may have either the regular cash commission or the name may be counted in a club)

Given as a reward for a club of TWO yearly subscriptions to the Farm and Fireside. Postage paid by us. Order by Premium No. 26.

# The Peerless Pictures

ON HEAVY ART-PAPER 20 BY 25 INCHES IN SIZE

Any THREE of the Pictures Listed Below Given as a Reward for Sending Two Yearly Subscriptions (new or renewal) to the Farm and Fireside.

ANY ONE OF THE PICTURES LISTED BELOW, AND THE FARM AND FIRESIDE ONE YEAR, FOR 35 CENTS. . . . .



No. 796 THE HORSE FAIR Size 20 by 25 inches

**SIZE** The Peerless series of pictures, including the margins, are 20 by 25 inches in size. Without the margins they are about 16 by 20 inches, varying somewhat according to the subject.

**STYLE** These pictures are reproduced in the very latest and most tasty style. They are not cheap chromos or attempts at color reproduction, which usually bear no resemblance to the originals.

### Grand Reproductions of Famous Paintings

IMMACULATE CONCEPTION . . . . .	Painted by Murillo . . . . .	Prem. No. 784
PHARAOH'S HORSES . . . . .	Painted by Herring . . . . .	Prem. No. 785
QUEEN OF FLOWERS . . . . .	Painted by Lester . . . . .	Prem. No. 786
AFTER WORK . . . . .	Painted by Holmes . . . . .	Prem. No. 787
CHRIST BEFORE PILATE . . . . .	Painted by Munkacsy . . . . .	Prem. No. 788
DEFIANCE, or STAG AT BAY . . . . .	Painted by Lundseer . . . . .	Prem. No. 789
KISS ME (Child and Dogs) . . . . .	Painted by Holmes . . . . .	Prem. No. 790
THE LITTLE SHEPHERDESS . . . . .	Painted by Koller . . . . .	Prem. No. 791
PORTRAIT OF WASHINGTON . . . . .	Painted by Stuart . . . . .	Prem. No. 792
THE FINDING OF MOSES . . . . .	Painted by Schopin . . . . .	Prem. No. 793
CAN'T YOU TALK . . . . .	Painted by Holmes . . . . .	Prem. No. 794
WATERFALL BY MOONLIGHT . . . . .	Painted by Rieger . . . . .	Prem. No. 795
THE HORSE FAIR . . . . .	Painted by Bonheur . . . . .	Prem. No. 796



No. 789 DEFIANCE Size 20 by 25 inches

This is the first time that faithful copies of the world's greatest works of art have been reproduced so they could be offered on such popular terms.

We Will Send the Farm and Fireside One Year and any Two of these Pictures for **50 Cents**

(When this offer is accepted the club-raiser may have either the regular cash commission or the name may be counted in a club)

**FREE** Any THREE of these Pictures, Your Choice, Given as a Premium for TWO Yearly Subscriptions to the Farm and Fireside.

The pictures will be sent by mail, securely packed and postage paid. Entire satisfaction guaranteed. A beautiful twelve-page circular giving illustrations and descriptions of the paintings sent FREE on request. Write to-day.

Address FARM AND FIRESIDE, Springfield, Ohio

Postage paid by us



# "ALPHA-DE LAVAL" CREAM SEPARATORS

The De Laval Cream Separators were first and have always been kept best. They have always led in improvements, which imitating machines must await the expiration of patents to use. The 20th CENTURY improvements give them still greater capacity and efficiency. They are immeasurably superior to any other system or method that can be employed in the separation of cream—saving \$3.00 to \$5.00 per cow per year over any other centrifugal method, and \$5.00 to \$10.00 over any setting system.

There are over 200,000 De Laval machines in use—ten times all others combined. Machines are made in all styles and sizes—from \$50 to \$800. Send for new 1900 catalogue.

**THE DE LAVAL SEPARATOR CO.**  
Randolph & Canal Sts., CHICAGO. 74 Cortlandt Street, NEW YORK.

## "Goshen" Tanks Represent Honest Tank Value...

and these are the reasons why: They are made of the best heavy galvanized steel they simply cannot warp, swell or fall to pieces from drying out; heavy iron bound edges protect them from bending or denting.

**ANTI-SEPTIC**  
there is no place for disease germs in these tanks. Pure water makes good milk and butter; prevents many diseases, hog cholera, etc. Don't buy until you get our 48 page catalogue, sent FREE. Kelly Foundry and Machine Co. 12 Purl St., Goshen, Ind.

## A RARE COMBINATION

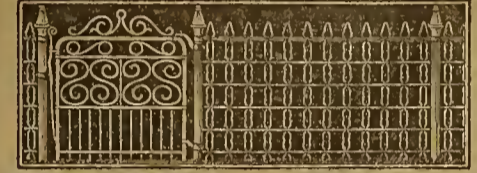

**HARTMAN STEEL ROD PICKET FENCE.**  
Best and handsomest for lawns, parks, cemeteries, school grounds—anything. Send for our free catalogue—know more about it. HARTMAN M'FG. CO., BOX 26 ELLWOOD CITY, PA. Or Room 77, 309 Broadway, New York City.



**CRESCENT FENCE**  
will last a lifetime. Composed of all large wires and steel stays. Catalogue and prices free. Address THE C. M. FENCE STAY CO., 11 Canal St., Covington, Ohio.

Soon Saves Its Cost. **A 12-Year Old Boy**  
A Labor Saver.  
can do more and better work, either in the field or garden, with the **HAND CULTIVATOR** than three men can do with common hoes. Plows, hoes, cultivators—stride or between rows. Innoagent in your town send \$1.35 for sample delivered and terms to agents. Ulrich Mfg. Co., 43 River St., Rock Falls, Ill.

**VICTOR Low-Down HANDY WAGONS**  
Strongest, most durable, all-metal wheels, wide tires. Axles, hounds, bolsters, etc., of thoroughly seasoned woods. Cost one-half less than high wagons. Positively guaranteed. Write for description and prices. GEO. ERTEL CO., Quincy, Ill.

**Don't Pay High Prices TO YOUR DEALER.**  
You can buy the **Advance Fence** direct from us at wholesale prices. It's a first-class fence in every way. Write for circulars and prices. **ADVANCE FENCE CO. 116 Old St., Peoria, Ill.**

**GOOD CIDER**  
Clear, Pure, Long Keeping Cider.  
and more of it from the small amount of apples can only be secured by using a **Hydraulic Cider Press**  
Made in various sizes, hand and power. The only press awarded medal and diploma at the World's Fair. Catalogue and price-list sent free upon request. Hydraulic Press Mfg. Co., 6 Main St., Mt. Gilead, Ohio.

**FARMERS**  
Send for a large Catalogue of the celebrated "DeLoach" VARIABLE FRICTION FEED SAW-MILLS, Shingle-Mills, Planers, Hay-Presses, Grinding-Mills, Water-Wheels, etc. Our Saw-Mill is warranted to cut over 2,000 feet of board lumber in ten hours with 4-horse power. Prices low, and we pay the freight. DeLOACH MILL MANUFACTURING CO., 300 Highland Avenue, Atlanta, Georgia.

**FOUR GOOD REASONS** why you should buy **BUGGIES** direct from our factory  
1st—YOU SAVE the DEALER'S PROFIT.  
2d—You get all custom-made & best material.  
3d—You get our **TWO** year guarantee.  
4th—You pay only after examining. Our \$28 Buggy \$47 Surrey or \$36 Top Family Wagon are wonders for cheapness. 4 tired wheels \$6.25, Buggy Tops \$5.25, Harness \$3.95. Catalog free. Purchasers can become successful agents aided by our private selling instructions. **U. S. BUGGY & CART CO. P 50, Cincinnati, O.**

**OIL Meal** [OUR OLD] THE VERY BEST Feed for [PROCESS] horses, cows, sheep, hogs, fowls, etc. Health, strength and productive power to animals. Are you feeling it? Cheap est feed in the market. For Oil Meal or Lined Oil and White Lead, ask for "Thompson's," or get circulars and prices. Thompson & Co., 509 W. Diamond St., Allegheny, Pa.

**ALUMINUM CREAM SEPARATORS "UP TO DATE" CHURNS.**  
On 10 days' trial, dairymen investigate before you buy; product increased 20 per cent. **CAT'S FREE, GIBSON-STEWART M'FG. CO. GIBSONIA, PA.**

# FARM SELECTIONS

## RAISING RAPE

I HAVE been asked to write a little about raising rape. I shall sow about fifty acres the coming season, and I will give a few hints as to my way of doing it. In the first place, get a field of blue-grass pasture next to the one where you wish to sow rape. Have your rape-field well covered with barn-yard manure if possible, and plow as early as you can. Roll the ground and harrow it two or three times to get it in fine condition. In a few days, or after each rain, harrow again, once for each time it rains, after the soil is dry enough to cultivate. This will kill all the foul weeds and put the soil in the same condition that you would to produce forty or fifty bushels of wheat to the acre. I sow broadcast about five pounds of seed to the acre from May 15th to June 1st. If sown after this I would drill in rows twenty-eight inches apart, and use two and one half pounds of seed to the acre.

Any time after the first of June we are liable to get dry weather, but if one will cultivate it about twice where sown in rows it will insure against drought later on, give a great stimulus to the growth of the plant, and produce a crop that will make \$20 of finished mutton, pork or beef to the acre, besides enriching the soil \$5 an acre.

My reason for having a field of blue-grass next to the rape is to counteract the looseness of the bowels and make a more perfect ration from using the two at the same time. Last season, for instance, I purchased fifty yearling Shropshire rams that had been poorly wintered. They weighed one hundred and thirty-eight pounds each on July 1st. I turned them on rape, with access to a blue-grass field, and fed them grain ration of corn and oats, one half pound a head each day. On October 1st they weighed one hundred and ninety pounds each. The gain would have been greater with the same number of lambs or wethers.

There is not a flock of lambs grown for mutton in Ohio, Indiana, Iowa, Illinois or Michigau but could be finished to a higher average weight from September 1st to December 1st in this way than by feeding all the long winter months and until May. The farm could winter two good breeding-ewes for what it costs to fatten one lamb in winter. Feed them grain while on rape pasture, and get better profits and in a shorter time.—L. S. Dunham, in the Shepherd's Bulletin.

## MINNESOTA CREAMERIES

Minnesota has 700 creameries, which receive the milk of 380,000 cows, from 54,000 patrons, and make therefrom a butter product of 61,000,000 pounds, of which 48,000,000 pounds are shipped to Eastern markets and sold as extras, much of it at one to two cents above the highest market quotation. These 700 creameries, representing a capital of \$2,800,000, handle 1,350,000,000 pounds of milk per annum, and after expending \$1,100,000 in the cost of manufacture, make a product from which they realize \$10,450,000, of which \$3,400,000 net is returned to the 54,000 patrons in payment of the butter-fat taken from the milk.—Farm Journal.

## HIS TROUBLES WITH TURKEYS

I have heard, dozens of times, women say that turkeys were difficult to raise. I have no doubt but that is true. But the madam with the eighty turkeys said that the difficulty often arose from neglect and forgetfulness. I only have her word for it. I don't know. I never raised, personally, a turkey in all my born days. Mrs. Agricola attends the poultry. The trouble which I have occasionally results from my efforts to borrow the poultry money. That seems to be enough.—The Corn Belt.

## FARM WAGON ONLY \$21.95

In order to introduce their Low Metal Wheels with Wide Tires, the Empire Manufacturing Company, Quincy, Ill., have placed upon the market a Farmer's Handy Wagon that is only 25 inches high, fitted with 24 and 30 inch wheels with 4-inch tire, and sold for only \$21.95.



This wagon is made of the best material throughout, and really costs but a trifle more than a set of new wheels, and fully guaranteed for one year. Catalogue giving a full description will be mailed upon application by the Empire Manufacturing Co., Quincy, Ill., who also will furnish metal wheels at low prices made any size and width of tire to fit any axle.

# 40 Cent Patterns for 10 Cents

We Will Send Any TWO PATTERNS, and This Paper One Year, for 40 CENTS

(When this offer is accepted the club-raiser may have either the regular cash commission or the name may be counted in a club)

These patterns retail in fashion bazaars and stores for twenty-five to forty cents each, but in order to increase the demand for our paper among strangers, and to make it more valuable than ever to our old friends, we offer them to the lady readers of our paper for the low price of only 10 Cents Each.

Full descriptions and directions—as the number of yards of material required, the number and names of the different pieces in the pattern, how to cut and fit and put the garment together—are sent with each pattern, with a picture of the garment to go by. These patterns are complete in every particular, there being a separate pattern

for every single piece of the dress. All orders filled promptly.

For ladies, give BUST measure in inches. For SKIRT pattern, give WAIST measure in inches. For misses, boys, girls or children, give both BREAST measure in inches and age in years. Order patterns by their numbers.

Satisfaction guaranteed or money refunded. To get BUST and BREAST measure, put the tape-measure ALL of the way around the body, over the dress, close under the arms.

Special price of each pattern 10 cents. Postage one cent EXTRA on skirt, tea-gown and other heavy patterns.

## FREE We will give any THREE of these patterns for FREE TWO yearly subscriptions to Farm and Fireside FREE

Address FARM AND FIRESIDE, Springfield, Ohio



No. 7878.—LADIES' SHIRT-WAIST WITH APPLIED YOKE IN SCALLOPED OUTLINE. 10 cents. Sizes, 32, 34, 36, 38, 40 and 42 inches bust.



No. 7861.—LADIES' SHIRT-WAIST WITH PLAIN OR PLAITED BACK. 10 cents. Sizes, 32, 34, 36, 38, 40 and 42 inches bust.



No. 7834.—LADIES' FANCY SHIRT-WAIST. 10 cents. Sizes, 32, 34, 36, 38, 40 and 42 inches bust.

No. 7838.—MISSSES' SIZE. 10c. Sizes, 12, 14 and 16 years.

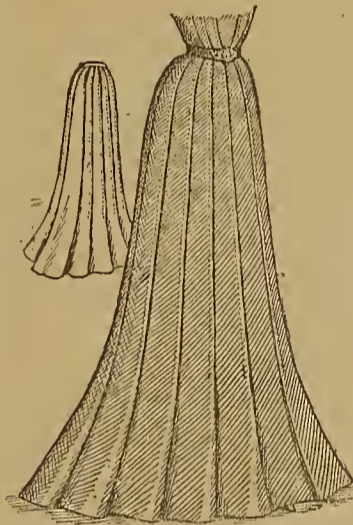

No. 7903.—LADIES' FOUR-PIECE PLAIED SKIRT. 11 cents. Sizes, 22, 24, 26, 28 and 30 inches waist.



No. 7764.—LADIES' WRAPPER WITH GATHERED WAIST. 11 cents. Sizes, 32, 34, 36, 38, 40, 42 and 44 inches bust.



No. 7955.—MISSSES' BOX-PLAIED SKIRT WITH APRON OVERSKIRT. 11 cents. Sizes, 12, 14 and 16 years.

No. 7952.—LADIES' SIZE. 11c. Sizes, 22, 24, 26, 28 and 30 inches waist.



No. 7947.—LADIES' FANCY WAIST. 10 cents. Sizes, 32, 34, 36, 38 and 40 inches bust.



No. 7922.—LADIES' PANEL SKIRT. 11 cents. Sizes, 22, 24, 26, 28 and 30 inches waist.



No. 7052.—LADIES' TEA-GOWN. 11 cents. Sizes, 32, 34, 36, 38, 40, 42 and 44 inches bust.

Any THREE patterns given free for a club of TWO yearly subscriptions to the Farm and Fireside.



**FARM SELECTIONS**

**NEW VARIETIES OF FRUITS**

AT THE meeting of the Eastern New York Horticultural Society Professor S. A. Beach, of the New York experimental station, gave an address on "New varieties of fruits not yet introduced." Among the new and desirable varieties of apples he spoke of the Arctic, which is now being planted in the Champlain valley in a small way. It is one of the hardiest of the American apples. It somewhat resembles the Baldwin in appearance. The quality is good and the tree is productive. Another apple now being introduced is the Bismarck. It is an early bearer, good size and fair quality, but is not a dessert-apple. The Greenville is a very handsome apple, and seems to be worth trying. The Ingram is a new apple that is a success in the West. It is being largely planted for the export trade. The Ontario is a seedling of the Northern Spy and Wagener. It has proved to be a good apple for Northern latitudes. The Rome Beauty can be safely recommended for general planting in southeastern New York, where spraying is practised. It bears annually, and has an established reputation in market. It is not a strong grower, and should be top-worked on other varieties. It is a good dessert-apple. The New York Imperial is in demand as an export apple. It is an early and abundant bearer and excellent keeper. Among the Japan plums the Burbank, Abundance and Red June have proved the best for the market. The Wickson is the largest, but the flavor is not high. It is not an early bearer, but is more productive as it gets older. Campbell's Early grape ripens between Moore's Early and the Worden. The flavor is better when left on vines for some time after ripening; it is worthy of trial. The Vergennes grape is winning favor; it is edible in October and keeps until Christmas. It is not a strong grower. —Vick's Magazine.

**RECENT PUBLICATIONS**

**BOOKS NOTICED**

**THE STUDY OF BREEDS.** By Thomas Shaw, professor of animal husbandry at the University of Minnesota, formerly professor of agriculture at the Ontario Agricultural College and editor the "Canadian Live Stock Journal." This great work gives the origin and history of all the pedigree breeds of cattle, sheep and swine now found in America in a manner at once brief, comprehensive and in regular sequence. It also deals with their present distribution. It treats of the characteristics of each breed, showing relative size, adaptability, early maturity, feeding and breeding qualities and uses in crossing and grading. It also gives relative milk production in cattle and wool production in sheep. It gives the recognized standards or scales of points where these exist, and where they do not standards are submitted. It is a summary of condensations stated in a manner at once clear, concise, comprehensive and exact. The time occupied in preparing this book has covered a large portion of twelve years. Illustrations are given of male and female animals of each breed that are true to the type. For farmer, breeder or student the book is the one complete and reliable guide. Upward of 400 pages, nearly 100 full-page plates; cloth, 12mo. Price, post-paid, \$1.50. For sale by Orange Judd Company, publishers, 52 Lafayette Place, New York, N. Y.

**THE PRODUCTION AND MARKETING OF WOOL.** By Herbert W. Mumford. A timely and valuable bulletin on the wool industry from the Michigan Experiment Station, Agricultural College, Michigan. Free.

**CATALOGUES RECEIVED**

- D. A. Mount, Jamesburg, N. J. Pine-Tree Farm catalogue of pure-bred poultry.
- The J. W. Miller Co., Freeport, Ill. Annual guide and catalogue of thoroughbred poultry.
- A. B. Kalkamier, Farmington, N. Y. "The Broom-Corn Trade Directory and Growers' Guide." Price 50 cents.
- Harlan P. Kelsey, Boston, Mass. Illustrated circular of information about ginsengs, and cultural directions. Price 10 cents.
- Edward W. Walker Carriage Co., Goshen, Ind. Illustrated catalogue of vehicles and harness sold direct from factory to customer.
- Wood Brothers, Chicago, Ill. Facts and Figures of Chicago Live Stock Trade for Twenty-two Years. Free to those interested in live stock.
- Field Force Pump Co., Lockport, N. Y. Illustrated catalogue of spraying-pumps, well-pumps, force-pumps, nozzles and spraying-machines, containing directions for spraying and formulas for mixtures.

N. E. A.

Reduced rates via Queen and Crescent Route from all points north to Charleston, S. C., account the great National Educational Association meeting in July. Free books. W. C. Rinearson, G.P.A., Cincinnati.

**A NEW WARRANTY**  
**Champion**  
**Binders**  
**Mowers**

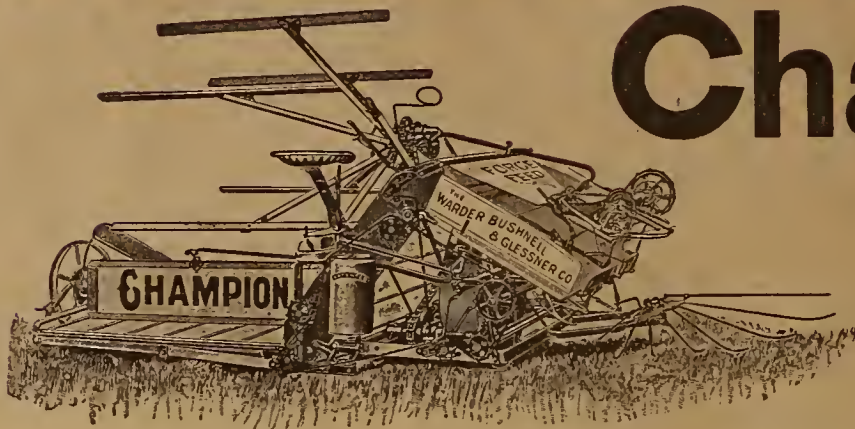

All warranties furnished by makers of Binders and Mowers state that the machines are durable, well made, and of good material, and give the purchaser one day's trial to determine all this. What can be told about the durability of a machine by using it one day?

But how about its work in the field? Something can be told about this, but there isn't one word about it in the warranty—only some directions about what the purchaser is to do when the machine does not work well. Isn't this singular?

How about wasting grain between the binder deck and the elevator; about lack of power when compressing the bundle? How about the loss of power on the push bar Mower when cutting tough grass? Just at the time you need the most power you have the least.

In their advertising all makers claim to have a device for keeping the knife and pitman in line, but only the CHAMPION MOWER has it, and others dare not put it in the warranty. The purchaser of a CHAMPION BINDER or MOWER gets a printed warranty containing the clauses for the protection of the purchaser found in other warranties, and in addition the following clauses which are not found in the warranties given by any other makers:

"The eccentric wheel on the CHAMPION Binder is warranted to give a gain of 16 2-3 per cent. in power for binding. The force feed elevator on the CHAMPION Binder is warranted to waste less grain than the elevator on any other Binder. The master wheels on the CHAMPION Draw Cut Mower are warranted not to lift from the ground when the cutter bar meets an obstruction. The cutter bar on the CHAMPION Draw Cut Mower is warranted to be adjustable, so that the outer end may be brought forward to keep the cutter bar in line with the pitman, and the sections may be kept always properly centered in the guards."

Think of it. These are the important features on Binders and Mowers. No other machines contain them. No other manufacturer dare warrant his machines to contain them. If any salesman offers to add to his warranty, beware of him. He is trying to fool you. A warranty is of no value except it is in exact form as issued by the company, and if changed in any way the company is not bound by it, nor is it any protection to the purchaser.

The factory in which CHAMPION Binders and Mowers are made was established fifty years ago. More patents for the improvement of CHAMPION Binders and Mowers have been taken out in the last five years than for all other Binders and Mowers put together. The CHAMPION Binders and Mowers are the modern machines. Many thousand agents are selling them all over the world.

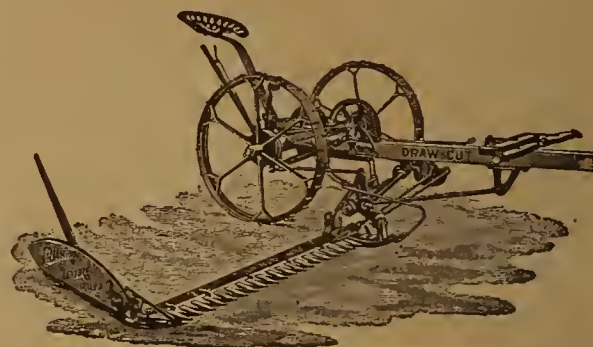

**The Warder, Bushnell & Glessner Company,**  
**SPRINGFIELD, O. Manufacturers of Champion Binders, Mowers and Reapers, CHICAGO.**

**Artistic Monuments**

**COST NO MORE THAN PLAIN ONES in White Bronze**

Marble is entirely out of date. Granite soon gets moss-grown, discolored, requires constant expense and care, and eventually crumbles back to Mother Earth. Besides, it is very expensive.

**White Bronze** is strictly everlasting. It cannot crumble with the action of frost. Moss growth is an impossibility. It is more artistic than any stone. Then why not investigate it? It has been adopted for nearly one hundred public monuments. We have designs from \$4.00 to \$4,000.00. Write at once for free designs and information. It puts you under no obligations. We deal direct and deliver everywhere.

**The Monumental Bronze Co., 547 HOWARD AVENUE, BRIDGEPORT, CONN.**



**WHY NOT PROTECT YOUR BUILDINGS**

Against **LIGHTNING, FIRE AND WATER?**

Buildings covered with steel are never struck by lightning! Our new Catalogue tells how to put on **STEEL ROOFING, SIDING** (imitation pine weatherboarding and pressed brick). Ceiling (fancy and plain). Lath, Galvanized Eave-Troughs, Conductor-Pipes, etc. Our Steel Coverings last a lifetime. Write for catalogue and prices. A 2-cent stamp may save you \$100.

**PORTER STEEL ROOFING CO., 41 W. Front St., CINCINNATI, OHIO.** (Established 1869.)



**BICYCLES BELOW COST**

**5,000 HIGH GRADE** guaranteed **MACHINES** with best equipment must be closed out.

1900 Models, best makes, \$11 to \$20 '99 & '98 Models, high grade \$8 to \$13

**500 Second hand Wheels** all makes and models, good as new, \$3 to \$10. Great Factory Clearing Sale at half factory cost. We ship anywhere on trini without a cent in advance. **EARN A BICYCLE** distributing Catalogues for us. Many earned a wheel last year. Our 1900 proposition is even more liberal.

Write at once for our Bargain List and Special Offer. Address Dept. 43 B.

**MEAD CYCLE CO. Chicago**



**A WOMAN'S NEW GAME**

is to enclose fowls with Page Poultry Fence. **PAGE WOVEN WIRE FENCE CO., Adrian, Mich.**

**SILVERWARE FREE**  
**48 PIECES FREE**

This handsome and valuable Silverware will be given free to every person who will help us to quickly advertise Howard's Vegetable Pills, a sure and safe cure for Constipation, Indigestion and Torpid Liver. We have contracted with a leading silverware Co. for large quantity of these goods and give them away to introduce our pills. You can take advantage of this offer. Write today and we will send you six boxes of our pills postpaid. Sell them at 25c. each and remit us \$1.50 and we will send you at once 12 tea spoons together with our offer of 12 forks, 12 knives and 12 table spoons same day money is received. The silverware is made with latest pattern and fully warranted to wear for years. **HOWARD DRUG CO., 38 Dearborn St., CHICAGO**



# FARM & FIRE SIDE

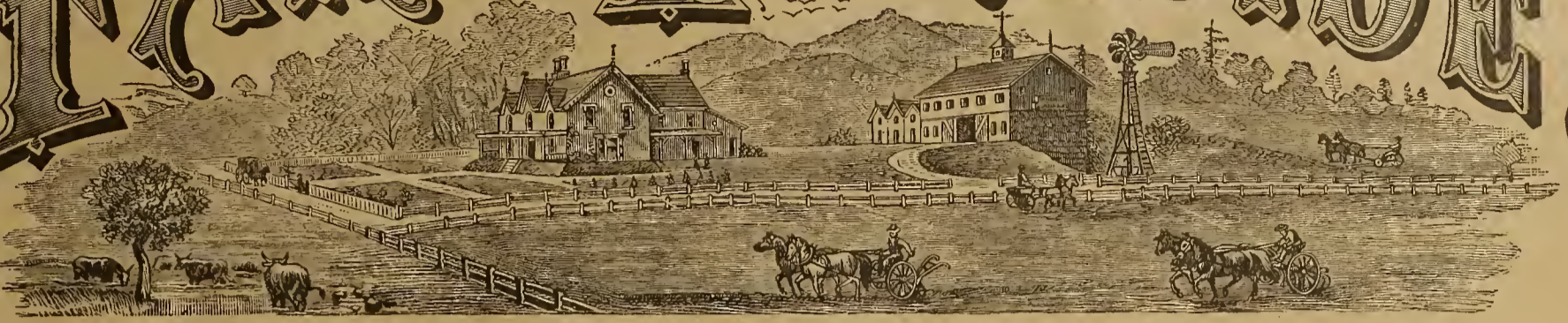

Vol. XXIII. No. 16

EASTERN EDITION

MAY 15, 1900

Entered at the Post-office at Springfield, Ohio, as second-class mail matter

TERMS { 50 CENTS A YEAR  
24 NUMBERS

## AMONG THE FOOT-HILLS OF THE ROCKIES

BY H. A. CRAFTS

THE lower foot-hills of the Rocky mountains lie in long parallel ridges like ocean billows, the hollows of which are grassy glades. In height they seldom exceed one hundred feet, and from crest to crest it may be a quarter of a mile. The substances entering into their composition are of almost infinite variety. There is red, white, gray and brown sandstone, limestone, fire-clay, gypsum, etc., which are found to be of great value to the builder. But the chief importance of these hills is the excellent pasturage they afford. The more rocky hillsides are somewhat scant of herbage, but the glades are carpeted with fine, soft grasses, buffalo-grass predominating; while in the narrow gulches, where springs bubble up and the moisture from the hillsides settles, there are rank growths of grass, reeds and long-stemmed wild flowers growing shoulder-high.

While the grass flourishes upon the hillsides, as it does during the spring-time and early summer, the cattle feed but little upon these spots of more luxuriant vegetation, frequenting them only to slake their thirst at the springs or to brush the flies from their backs against the protruding branches. For shade during the heat of summer they seek the quaking asp or cottonwood groves that grow higher up in the glades, through which, while the sun is on high, sweep cooling breezes blowing up from the plains and through the clefts in the hills. But when heat and drought of late summer, the frosts of autumn and constant grazing have had their effect, the cattle love to browse in the quiet, sheltered dells, where the sun shines warmly and the brisk breezes of winter are broken by the surrounding cliffs. And more welcome still are these spots when snow has fallen and lies at considerable depths on the hills. Then, so long as the tall grasses and reedy stalks last, the cattle are not put to it to "rustle" for a living. For night shelter, too, even in the coldest weather, the cattle prefer these secluded nooks to the best-constructed sheds or corrals. The southern exposures of the steep, rocky cliffs doubtless absorb consider-



MOUNTAIN STREAM IN THE FOOT-HILLS OF THE ROCKIES

able heat from the sun during the day, and hold it in reserve during the night to temper the rigors of the surrounding atmosphere and make the long winter nights more tolerable to the unhoused brutes.

Charming views, indeed, these low hills and narrow valleys present, especially when spring, summer or autumn throws its soft witchery over the landscape! In spring and summer clothed in softest greens, and in the more sober period of the year in softest

browns, blending finely with the delicate grays and reds of the rocky outcroppings, and even with the red clays that form the soils of many of the hilly slopes. It is a peculiar feature of these long ridges that they are sloping to the east, but on the west are quite precipitous, as if broken sharply off by some violent convulsion of Nature in the remote ages of the past, showing, in heights ranging from fifty to one hundred feet, the various strata composing the

name of mountains. They are quite distinct in formation from the first foot-hills. To be sure, they form ridges, but these ridges are veritable mountain ranges. Some of the hills are bald, others rise into ragged, pointed crags, while others are flat or round on top and crowned by a fine growth of pines. Delightful vistas often break upon the sight, as, wandering up or down these glades, we come suddenly opposite one of those passes or canons segregating the ridges just described. It is as if the curtain had been suddenly lifted from a beautiful painting. Just beyond the pass rises the fair slopes of a grassy hillside, seamed here and there by an outcropping of rock, and dotted by hardy pines.

The eye climbs far up before the crest is reached, where the dark pine groves stand against the deep blue sky, and catches the shimmer of sunshine as it flitters in fine shafts through the foliage of the pines. Richness, brilliancy and purity are its characteristics; and to still heighten the effect there are cattle feeding everywhere—on hillside and in gulch, in valley and upon mountain-top—their sleek sides glistening in the full tide of a summer's sun. For a verity the cattle are "upon a thousand hills;" and here, in fact, are Colorado's most choice pasturelands. Sun, air, water, shelter, shade and forage, all are found here, and



FOOT-HILL RANCHES IN THE ROCKIES

[CONCLUDED ON PAGE 20 OF THIS ISSUE]



## FARM AND FIRESIDE

PUBLISHED BY

THE CROWELL &amp; KIRKPATRICK CO.

OFFICES:

147 Nassau Street,  
New York CitySpringfield,  
Ohio204 Dearborn Street,  
Chicago, Illinois

Subscriptions and all business letters may be addressed to "FARM AND FIRESIDE," at either one of the above-mentioned offices; letters for the Editor should be marked EDITOR.

## TERMS OF SUBSCRIPTION

One Year - (24 Numbers) - 50 Cents  
Six Months - (12 Numbers) - 30 Cents

The above rates include the payment of postage by us. All subscriptions commence with the issue on press when order is received.

Subscribers receive this paper twice a month, which is twice as often as most other farm and family journals are issued.

**Payment**, when sent by mail, should be made in Express or Post-office Money-orders, Bank Checks or Drafts. WHEN NEITHER OF THESE CAN BE PROCURED, send the money in a registered letter. All postmasters are required to register letters whenever requested to do so. DO NOT SEND CHECKS ON BANKS IN SMALL TOWNS.

**Silver**, when sent through the mail, should be carefully wrapped in cloth or strong paper, so as not to wear a hole through the envelop and get lost.

**Postage-stamps** will be received in payment for subscriptions in sums less than one dollar, if for every 25 cents in stamps you add one-cent stamp extra, because we must sell postage-stamps at a loss.

**The date** on the "yellow label" shows the time to which each subscriber has paid. Thus: Jun 1900 means that the subscription is paid up to June, 1900; Jul 1900, to July, 1900, and so on.

**When money is received**, the date will be changed within four weeks, which will answer for a receipt.

**When renewing your subscription**, do not fail to say it is a renewal. If all our subscribers will do this, a great deal of trouble will be avoided. Also give your name and initials just as now on the yellow address label; don't change it to some other member of the family; if the paper is now coming in your wife's name, sign her name, just as it is on the label, to your letter of renewal. Always name your post-office.

## The Advertisers in This Paper

We believe that all the advertisements in this paper are from reliable firms or business men, and do not intentionally or knowingly insert advertisements from any but reliable parties; if subscribers find any of them to be otherwise we should be glad to know it. Always mention this paper when answering advertisements, as advertisers often have different things advertised in several papers.



**DISCUSSING** the farmer's share in the expansion of export trade Mr. Frank H. Hitchcock, chief of the section of foreign markets of the Department of Agriculture, recently said:

"Our sales of agricultural products abroad during the last three years were over \$500,000,000 greater than in the preceding three years, 1894-96. This enormous gain affords some idea of the possibilities that await a further development of our agricultural export trade.

"Wider markets are becoming not only an advantage, but a necessity. The products of our farms, like the products of our factories, are increasing far beyond our own requirements, and the surplus thus resulting must be disposed of abroad or we shall have a constant glut in the home market. To avoid such a condition we are striving as never before to increase our shipments to foreign countries. We are searching the world over to find new markets in order that the American farmer may have a readier and more profitable sale for his products.

"Our control of the markets of Cuba and Puerto Rico will mean money in the pockets of our farmers. Under normal conditions these two islands purchase annually \$50,000,000 worth of agricultural produce, chiefly breadstuffs and provisions, and practically all of this trade should come to the United States.

"In due time the Philippines also will furnish an important market for the produce of American farms. This group of islands is particularly important because of its relation to the valuable commerce of the Orient. All the great commercial nations are expectantly looking toward China, with her 400,000,000 people, as the most promising field for trade development the world now offers. The American farmer wants a share in that trade. With a commercial foothold in the Philippines, and a naval base there to insure the protection of our commerce on the Pacific, we shall be better able to reach forth into the coveted markets of China, Japan and the rest of Eastern Asia.

"The foreign trade of China, Japan and the East Indies, even under the present un-

developed conditions, amounts to more than \$1,000,000,000 a year, and of this vast commerce the United States enjoys less than ten per cent. The possibilities of commercial expansion in this direction are simply enormous. Our exporters are beginning more fully to recognize this fact and to take advantage of it. The results already obtained are significant. Five years ago our exports to China and Japan were valued at little more than \$12,000,000; last year they amounted to nearly \$40,000,000. Products of the farm enter extensively into this rapidly growing trade. The cotton-planter of the South and the wheat-grower of the North and West are alike benefited. During the last year more than 100,000,000 pounds of American cotton were shipped to Japan, as compared with only 11,000,000 pounds five years ago. Our exports of wheat-flour to Asia in the meantime have increased from less than 1,000,000 barrels to over 1,500,000. Many other agricultural exports of the United States are finding a new and profitable market in the Orient, and all indications point to the development there of an extensive trade in the products of agriculture.

"The farmer's benefit from commercial expansion, however, is not measured merely by the larger sale of his own produce abroad. He profits nearly as much from the growing exportation of manufactured wares. The increased production of manufactures in the United States to meet the requirements of a broadening export trade naturally creates a larger home demand for the products of the farm. Every additional pound of cotton cloth sent to Asia means a better market at home for our raw cotton; every additional pair of shoes sold abroad means a better market here for hides of cattle, and so on through the long list of agricultural products that form the materials of manufacture. Then, too, all the various industries that are extended to meet a growing export demand require additional workmen, and these workmen must be fed from the produce of the farm. Thus the American farmer finds that the policy of commercial expansion results to his great advantage in the home market as well as in the foreign market."

**THE** statistician of the United States Department of Agriculture has issued a statement showing the wheat crop of the world for the five years, 1895 to 1899. This statement includes the department's first estimate of the crop of 1899 and a revision of estimates of the four preceding years.

WHEAT CROP OF THE WORLD, 1895 TO 1899

CONTINENTS	1895	1896	1897	1898	1899
North America.....	534,598,000	491,048,000	595,951,000	758,303,000	622,264,000
South America.....	83,915,000	57,492,000	39,510,000	66,603,000	112,331,000
Europe.....	1,460,357,000	1,509,066,000	1,158,236,000	1,579,758,000	1,499,604,000
Asia.....	431,146,000	379,320,000	375,088,000	434,771,000	399,196,000
Africa.....	50,835,000	43,488,000	37,200,000	46,630,000	35,800,000
Australasia.....	32,461,000	25,906,000	27,652,000	34,980,000	56,212,000
Total.....	2,593,312,000	2,506,320,000	2,233,637,000	2,921,045,000	2,725,407,000

PERCENTAGE OF WORLD'S CROP PRODUCED ON EACH CONTINENT

CONTINENTS	1895	1896	1897	1898	1899
	Per cent	Per cent	Per cent	Per cent	Per cent
North America.....	20.61	19.59	26.68	25.96	22.83
Europe.....	56.31	60.21	51.85	54.03	55.02
Asia.....	16.62	15.13	16.79	14.88	14.65
Africa.....	1.97	1.74	1.67	1.60	1.32
South America.....	3.24	2.30	1.77	2.28	4.12
Australasia.....	1.25	1.03	1.24	1.20	2.06

Official crop reports of the countries enumerated have been utilized where such reports were obtainable; in a few instances where official data were not issued or had not yet been received estimates have been based upon the information which seemed most trustworthy.

"Commercial interest in this statement naturally centers in the crop of which a portion still remains in the hands of producers and dealers, the crop of 1899. The sufficiency of this crop to supply all demands during the present crop year would seem to be incontestable. The aggregate world's production in 1899 amounted to 2,725,407,000 bushels; a decrease, it is true, of 195,638,000 bushels, or a little less than seven per cent from the crop of 1898; but compared with the average of the four preceding years, 1895 to 1898—a comparison which is obviously more satisfactory—the 1899 production shows an increase of nearly six and one third per cent, or, expressed in quantity, of 161,833,000 bushels. The increase from year to year in the amount consumed, a fact that is universally conceded, has doubtless so enlarged the

absorptive capacity of the markets that last year's crop may prove no more than sufficient for consumption and necessary reserves.

"A fact that strikes the attention, especially in the table of percentages, is that Europe, which produced 80,154,000 bushels less wheat in 1899 than in 1898, actually produced a greater percentage of the total world's crop in 1899 than in the previous year—55.02 per cent in 1899 against 54.08 per cent in 1898. Moreover, if the year 1897 be included in the comparison, it is noticeable that the trend of percentages of the world's crop produced on the European continent in the years 1897, 1898 and 1899 has been in a directly opposite direction from the trend of percentages of production in North America. The European production, which reached the low point of 51.85 per cent of the world's crop in 1897, rose in 1898 to 54.08 per cent, and to 55.02 per cent in 1899; the North American production, on the other hand, which was 26.68 per cent of the world's crop in 1897, fell in 1898 to 25.96 per cent, and in 1899 to 22.83 per cent. This opposing trend of production, as related to the total world's crop, was of course due, in a small degree, to variations in the production of the four other continents.

"Europe, it should be remembered, not only produces more than one half of the world's crop, but consumes almost the entire world's surplus. North America, on the other hand, raises between one fourth and one fifth of the world's crop, and is the world's great surplus exporter. Between these two great wheat-producing regions is transacted the bulk of the intercontinental wheat trade of the world. Prices, therefore, are certain to show more or less sensitiveness to changes in the proportions of the world's crop produced on each of these continents, the one an importer from necessity, the other the principal contributor of the world's surplus. In 1897 the exceptionally low proportion of the world's crop produced on the European continent, 51.85 per cent, furnished a substantial basis for an advance in world's prices. The high proportion of the same year's crop produced in North America, 26.68 per cent, gave this continent a controlling position in the situation. But for the slight increase in the percentage of the 1897 world's crop produced in Asia and Australasia it is evident the North American control would have been practically complete. Since that date a reversal of these conditions in Europe and North America, especially marked in 1899, has probably had some influence in maintaining persistently low prices for wheat in spite of a very marked upward tendency

hulls, beans and dead berries, to say nothing of the fake beans with which the real beans are mixed. Chicory, too, is popular in the lower grades. All these additions give the coffee an exceedingly bitter taste. I have often purchased in Washington coffee from which I easily selected the manufactured beans. I have quite a collection of imitation beans.

"I would advise coffee devotees to buy the unground coffee, as they are more apt to secure the real article. Ground coffee is so easily adulterated that many persons refuse to buy it, preferring to take a little more time by doing the grinding themselves and achieving in the end far better results.

"Sugar and salt are as a rule absolutely pure.

"Molasses and maple-sugar, however, are greatly adulterated. There is more of the latter sold by ten times than the product of the entire country. Maple-sugar is generally mixed with brown sugar, and the public does not know the difference. Persons who would not deign to taste common brown sugar relish it when in the form of maple-sugar.

"Ground mustard, pepper and all spices are far from being what they appear. Indeed, there are factories in a flourishing condition which do nothing else than make fillers for condiments. Mustard is generally flour and turmeric, with a sprinkling of the real thing.

"The beautifully colored jellies that invalids love are generally nothing more than glucose and the extract of apple parings and cores artificially flavored and colored with coal-tar dye. The majority of fruit delicacies, sad to say, were never at any time in the vicinity of orchards. These buckets of preserves, damson, etc., that sell by the pound and taste like shoe-blackening, are most wonderfully put up.

"Perhaps the most injurious substances in foods are the antiseptics found in canned vegetables, soups and beverages, such as beers and wines. Catchup generally is put up with an antiseptic."

**THE** Grout bill, now pending in the House of Representatives," says Secretary Wilson, "proposes to tax imitations of butter. I am utterly unable to find a reason why this should not be done, and I believe it to be the paramount duty of Congress to pass the bill without delay.

"There is no comparison between genuine butter and oleomargarine, and all claims to the contrary are easily disproven. When the millionaire and the laborer either go to market to buy the cheapest fats or tallow from the steer or the sheep they have no difficulty in getting them at the prevailing market prices. If they desire, however, to purchase the fats of the dairy-cow they are met with different considerations. The butter of the cow, which is composed of fat and casein, sells on its flavor. All other fats are different from this. The fat or tallow of the ox or the sheep may be had for four, five or six cents a pound, while that of the dairy-cow commands in its best condition at present over thirty cents a pound. Whenever the manipulation of a cow's milk is conducted under cleanly conditions and at a proper temperature a flavoring element enters it by reason of microscopic fat growths, which are bacteria. These bacteria make the fine flavor, for which we pay thirty cents a pound and more, and also add to the digestibility and healthfulness of the product. Other fats do not contain these germs, for the reason that there is nothing in them upon which they may live and multiply.

"Now, when the millionaire and the laborer either go to the market and are led into purchasing these cheaper fats rigged and jockeyed in such a way as to imitate butter, they are not only deceived and robbed, but they are made to introduce into their stomachs and the stomachs of their families substances that are injurious to their health beyond any question. The deleterious qualities of body-fat and tallow, such as are largely used in the production of imitation butter, cannot be eliminated by deodorizing processes or such things. Let any one take a piece of bread and butter, weighing the butter, and eat it, and then take a piece of bread and tallow, weighing that, and eat the first one day and the second the next, and he'll find the difference quickly."

**COMMENTING** on the pure-food question Dr. Wiley, the chemist of the Department of Agriculture, says that the value of the adulterated foods sold annually in the United States amounts to millions of dollars. Speaking of some of the common articles of food he says:

"Coffee could no doubt be made far more genuine than it is at present. The lower grades of coffee contain many imperfect





## ABOUT RURAL AFFAIRS

### Keep Cool

If you ever have been an interested listener in court proceedings, either as a juror, a witness or in any other capacity, you may have seen the attorney of one of the parties work himself into a frenzy of excitement in his pleadings, and make the most vehement and passionate appeals to court or jury, and you may have wondered about the little effect that all his efforts had on the minds and actions of the person or persons whom he wished to move. You may also have seen another lawyer step up quietly, and in a calm, deliberate manner and in plain, moderate language try to convince judge or jury of the correctness of his position. And then you may have noticed the deep impression his quiet arguments were leaving in the hearers' minds. It is an old Latin proverb that says, "Fortiter in re, suaviter in modo," and translated into plain American means, "You can attract more flies with molasses than with vinegar." It is well to use strong arguments, but we must be very careful how we express them. People never attach the same weight to the sayings of a person who appears excited as to those of the man who is calm and talks deliberately. In fact, it pays us well to keep cool and weigh our words before we let them go out of our mouths. A great many of the things that are said in the heat of passion or excitement do more damage to their originator than to the party whom they were intended to hurt. And the former would often give a good deal afterward if those things had been left unsaid.

\*\*\*

### The Peace-maker

Recently I attended a session of the grand lodge of one of the largest fraternal orders in existence anywhere. There were a number of troublesome questions and difficulties to be settled, and at times the proceedings threatened to become turbulent and heated. But there was one of the pillars of that organization, a man of commanding appearance and voice, who always appeared just in the nick of time as a peace-maker. He spoke quietly, deliberately, apparently taking a middle ground between the extremists on both sides, and his "let us consider whether this is a wise move or not," and his advice that always seemed to be based on good common (so-called "horse") sense, invariably carried the day. Blessed be the peace-maker! I could not help at the close of the session to go to this man, to shake hands with him, and to express my appreciation of his noble course, which undoubtedly saved us a lot of trouble and hard feelings.

\*\*\*

Nobody will fail to recognize the soundness of the advice not to worry over two kinds of disagreeable things; namely, those that can be remedied and those that cannot. Why worry over the former instead of taking the only sensible course of changing them when it is in our power to do so? And what is the use of worrying over things that cannot be helped, and must be endured willy-nilly? The trifling troubles and tribulations of life, the pin-pricks and flea-bites, are often very exasperating and annoying. The numerous petty quarrels among neighbors belong to this category. They often lead to a good deal of trouble and bad blood, and in most cases uselessly and senselessly and for the most trifling causes. Surely there are troubles enough in life which we cannot avoid, and real troubles, too. Why add to them so many—and often only imaginary ones—of our own making? People rush to the local justices with petty troubles and quarrels that a few quiet words, a little of the spirit of "let us reason together," would have settled without any difficulty, and to the satisfaction of both sides. The title of the local magistrates is "justice of the peace," and, as their name indicates, they should be peace-makers rather than judges, and their advice in this direction, if given with calmness and fairness, should and would lead to a settlement of the matter without going to process of law, at least in the great majority of cases. Law-suits cost money and make bad blood, and for that reason are seldom profitable or satisfactory. Often you are the loser even if you do win the case. Keep out of legal entanglements if such are at all avoidable. Save your temper, your reputation and your money. In a serious case give it into the hands of a good lawyer on a well-considered and well-understood basis of fair and reason-

able compensation. That is about all the advice one could give in a general way.

\*\*\*

### Cow-pea and Soy-bean

That the cow-pea or bean is to the South what clover is to the North has become quite generally recognized. For some years back the limit of the successful and profitable culture of this leguminous crop has been extended further north with every succeeding year until now it is grown to some extent in this state (New York), and as far north even as southern Vermont. In the Northern states, however, the seed does not always mature, and the value of the cow-pea lies more in the direction of a forage crop than a crop for seed, although I have secured ripe seed of some of the earlier sorts without difficulty. I have had these varieties when planted in drills three feet apart completely cover the ground with a perfect mat or tangle of vines, and perhaps I might have found this growth excellent both for green fodder or for bean hay. Unfortunately I tried it only in a small way for green feed, and it seemed to answer the purpose well; so well, indeed, that I intend to try it once more on a larger scale. The beans will be planted with a common grain-drill, or possibly broadcast. I anticipate good results.

\*\*\*

In earlier issues I have repeatedly referred to the soy-bean, alias soya-bean, alias American coffee-berry. I may have spoken slightly of it as a forage crop simply because the plant when it matures loses all its leaves, so that nothing but a bare stalk remains, of course heavily loaded with grain-filled pods. The Ohio Experiment Station has just issued a press bulletin speaking of the soy-bean as a substitute for clover. The station people claim to have grown it for several years with very satisfactory results. Planted on some of their poorest soils it has produced two to three tons of excellent dry forage or hay to the acre, which is eaten with relish by all kinds of stock. And as a crop to turn under for green manure the station has not found its equal. The following directions are given:

\*\*\*

"As the soy-bean is a warm-weather plant it should not be planted before the last of May in northern Ohio, nor before the middle in the southern part of the state. When planted for forage it is sown at the rate of one and one half bushels to the acre, on well-prepared land, sowing with the wheat-drill with all the runs open. Thus sown it soon covers the ground, and there is no trouble from weeds or foxtail. It should be harvested before frost, and cured as hay. The soy-bean, like clover, adds nitrogen to the soil, and it is therefore a renovating instead of an exhausting crop. It is especially suited to take the place of clover in a systematic rotation where the clover has been killed out by severe winters, as is the case at present over a large part of Ohio, or where the spring seeding of clover has failed to catch. There are several varieties of soy-bean, some of which will mature seed in Ohio, while others will not. As a rule the latter class are more valuable for forage, as they make larger growth. The beans, however, which are produced at the rate of ten to twenty bushels an acre, are a valuable feeding stuff, as they are quite high in protein, and to some extent take the place of such materials as linseed-meal in the ration. The Kansas station has fed them to fattening hogs with the result of effecting a large saving in the quantity of food required to make a pound of pork, and others report similar results in feeding them to sheep."

\*\*\*

As I have stated before, the American coffee-berry, an early variety of the soy-bean, has found a place on my ground for a number of years. On fairly good soil one can grow twenty to thirty bushels to the acre, and yet when I want the grain for feeding to stock, whether hogs, cattle or poultry, I believe I can do better by growing Canada field-peas, with or without oats. But I do believe I must try a good-sized patch of this coffee-berry for forage purposes, although I fear that it will not be so dead easy to cure the immature growth well enough to keep as well as hay; that is, when stored in a mow like hay. We should remember, however, that this crop may be of particular use on rather poor soil, where other crops would be likely to fail.

**Soil for Beans** A reader asks me what soil is best for bush-beans; should it be very rich or rather poor. People used to speak of soil "too poor to raise white beans," thus inferring that beans can be grown on very poor soil. I do not know of any crop for which I would prefer really poor soil. The ordinary white bush or field bean likes a warm, well-drained soil that is reasonably well supplied with mineral plant-foods. I would not want it very rich in nitrogenous matter for fear of getting an excess of vine at the expense of beans. For string-beans, however, I always try to select rather rich ground, of course, warm and well drained. In this case we want plenty of vine growth in order to have a continuation of pod production.

T. GREINER.

### SALIENT FARM NOTES

**Corn-growing** The fact that farmers, hundreds of them, in all parts of the country are asking all sorts of questions about corn-growing is good evidence that there is going to be some radical changes made in the methods of growing this great cereal. And it is plain that these changes are going to be made for the better—for larger production and better quality. It is a change that is to be welcomed, and I am glad to note that those who address farmers' institutes on this topic are gradually dropping fanciful theories and confining themselves to practical facts and methods. One great obstacle in the way of progress along these lines is the idea possessed by so many farmers that one must grow a large area—a large number of acres—to make it pay. "I have only thirty acres for corn this year," said a farmer to me a few days ago. "Tried to rent ten or twenty more, but couldn't get it." He has three good horses and a fair outfit of implements, and could manage about twenty acres well, but he feels satisfied that he could manage forty or fifty quite as well as twenty, and get twice the quantity of corn. He has been growing corn more than twenty years, and follows the same methods he practiced at the beginning, and never to my knowledge has he secured a yield of over fifty bushels to the acre, while his average has been about thirty-five. It is such farmers as he who keep down the average yield of all crops they grow. If the season is favorable for a crop they obtain a fair yield; if unfavorable they get little or nothing.

\*\*\*

I know other corn-growers who live in the same locality as the man above mentioned who long ago got out of the ruts traveled by the "average" farmer and are quite up to date in their methods and management, and they are getting good crops every year. One of them, who has two good teams, and a strong boy to help, says that he thinks thirty-five to forty acres all he can properly care for. And if the season proves very unfavorable he limits his efforts to twenty-five acres. Another, who has one good team, never attempts to grow more than twenty acres, and he declares that he can find all the work he can do on that "small patch." These men are alive and progressive and can give a good reason for everything they do. They don't do things because their neighbors do them, but because they know they are the right things to do at that time.

\*\*\*

A forty-acre farmer who grows sixteen to twenty acres of corn each year gave me a brief outline of his methods recently, and they are worth repeating here because of their practical details. The soil is kept fertile by means of stable manure, cow-peas and clover. In the spring it is plowed six inches deep and thoroughly pulverized with the harrow just as soon as it is in a "crumbly" condition. He tells me that he has often stopped his plow in the middle of the forenoon and afternoon to harrow a strip that had just reached the proper condition for harrowing. He says land will remain in first-class condition for plowing several days, but plowed land will not remain in first-class condition for harrowing many hours. He harrows it thoroughly and plants at once. If for any reason he is not able to plant immediately after harrowing, he goes over it again before he does plant. His object is to have the soil thoroughly and freshly pulverized when the seed is put in. His seed-corn is carefully selected in the early autumn, thoroughly cured, and kept in a dry place all winter, and not one grain in a hundred fails to germinate and send up a vigorous shoot. The planting is shallow—not over two inches for the deepest. This is easily managed because the soil is perfectly smooth—entirely free from lumps and sods—and level, and the planter runs as steadily as a sleigh.

The planter drops three and four grains in hills forty-four inches apart in rows the same distance apart. His object is to get three good stalks in each hill, and counting one hundred ears to a bushel a stand like this gives him ninety-three bushels an acre. He says two thirds of the hills will have four stalks in them, but quite a number of them will be barren, though he is slowly reducing the number of these by careful selection of his seed each year. He has grown as high as one hundred and twenty-two bushels to the acre in favorable years, but he "feels quite well" if he gets between eighty and one hundred. After the corn is planted and before it sprouts the ground is harrowed twice with a slanting-tooth harrow, and nothing more is done until the corn is four or five inches high, when cultivation begins with narrow-shoveled cultivators running four to five inches deep. As the plants increase in height and the roots extend into the rows cultivation is more shallow, and ceases when the bow of the cultivator will no longer pass over the plants. The first cultivations are intended to keep the soil mellow and loose, so that the roots will readily run through it, and hence the shovels are run deep. Later cultivations keep the surface mellow and destroy weeds.

\*\*\*

It will be noted that the soil is thoroughly pulverized and fined before the seed is put in; that the seed is alive and its germinating qualities perfect, and consequently the start of the plant is strong; that these two conditions insure rapid early growth; that the soil through which the young roots must pass is kept in a loose, mellow condition; and finally, that these roots are not broken nor disturbed by the later cultivations, which keep the surface open and mellow and destroy all weeds and grasses that may spring up. This is almost ideal corn culture, and is certain to result in full crops if the soil is rich. The fact that the one who practices this method secures more than double the yield that even so-called good farmers obtain is proof that it is as nearly perfect as practical methods well can be.

\*\*\*

### Rape

R. C. G., Iowa, asks a dozen or more questions about rape. One of his questions is, "Will it do well on land that is somewhat run down? If it will I intend to sow a few acres of such land to it and then pasture with sheep to bring the soil up." The same kind of soil that will make good cabbage will make good rape. Any market-gardener will declare that he does not know how to get land too rich for cabbage. It is a gross feeder and demands a soil that is "rich as cream." So also does rape. I have tried it on soil that was rather poor and cold, and in three months it reached a height of about seven inches, and the leaves were tough and leathery. But on very rich soil it grows like weeds and yields a vast quantity of food that is succulent and makes fair feed for cattle, sheep and hogs, and an especially good green food for yarded fowls. So far as my experience goes it would be a waste of seed to sow it on land that is thin, poor, heavy or cold. R. C. G. can bring his soil up much quicker with cow-peas than with rape and sheep. He should sow the Black variety about the middle of May, or immediately after corn is planted, cut for hay when the lower pods are ripe, and if there springs up an aftermath, as most likely there will, he can pasture that off, then sow the same tract to cow-peas again next year, and the following year I think he can get a good crop of oats or corn off the land.

\*\*\*

### New Forage Plants

I am asked if I know anything about some of the wonderful grasses and so-called "forage plants" so highly lauded by some seedsmen. I do not. Have given none of them a trial, and would advise those who intend doing so to go lightly. Without a doubt some of them will prove to be tough customers and very difficult to get rid of. About twenty-five years ago a bee-keeper was induced by the high commendations of interested parties to introduce into his locality a "bee-plant" that was said to yield great quantities of the richest kind of honey. He "introduced" it by procuring a quantity of seed and scattering it along the roadsides as he drove about the neighborhood. The poor old fellow thought he was a great public benefactor, but the plant proved to be a most pernicious weed, and it spread over the country rapidly, and the old man was execrated by all who knew him to be the introducer of the pest. Let the experiment stations test "new" grasses and "forage plants" lauded by seedsmen; they can afford it, then if they prove valuable we can plaut them without fear.

FRED GRUNDY.



## OUR FARM

### FARM THEORY AND PRACTICE

**HIGH PRICE OF FEED.**—The high price of fat stock in market and the very late spring combined to make feeding stuffs relatively scarce and high in price. The grain consumed by our farm-horses; this summer, no matter whether produced upon the farm or purchased in market, is using up money very fast. The first feed that can be secured this summer to take the place of the present costly feed is clover hay, and there will be inducement to all to make the hay on time this year, so that it will have the greatest nutritive value, and displace some grain in case of farm work-horses. I know that some farmers do not believe that clover hay is ever fit feed for a horse, but if it were made right and not fed to excess this opinion would not continue to exist. A stalk of clover cut when in full bloom and cured without any sun is about as rich as an equal weight of mixed grain. But it makes a bulky food that is laxative. If a horse is fed all that it can eat of such food, especially if there is some dust in it, the horse will become soft and out of condition; but if the hay is properly cured, and is fed in reasonable amount with some old timothy, the grain ration can be cut down one third or more, and the horse will gain in flesh. I refer to farm-horses at hard work. On farms where all horses are not at full work every day even more clover and less timothy may be fed. The prejudice against clover hay is largely due to late cutting, bad curing, the presence of weeds and overfeeding. It is a wonderful feed in its place, used in reason, and this year should have extra attention as a means of saving grain that either costs or may be converted into good money on the right side of the farm ledger.

\*\*\*

**THE SOUTHERN COW-PEA.**—Interest in the cow-pea for northern latitudes continues to grow. It is the great renovating and forage crop of some sections of the Southern states, and has given satisfaction in the southern tier of our Northern states when planted in warm soils. Many years' experience with this plant on a somewhat extensive scale in the latitude of Cincinnati enables me to speak of it with some definiteness. Enthusiasts naturally praise anything too highly, and this pea in the North is no exception. But that it has a place of value in our agriculture I know, and its use will increase in sections favorable to it. The drawbacks to the culture of this crop are these: It takes the summer for its growth, thus displacing a cash crop, and it cannot be accounted a safe forage crop. The hay when cured right is rich feed, but the curing with us must come in September, and then even more than earlier in the summer it is very difficult to make the vines into hay. North of the Ohio river I do not look upon the cow-pea as a crop for hay. The peas can be pastured, and are worth considerable as food for hogs just as soon as the pods begin to turn yellow. In this way we can get some cash return from the crop while improving the land. Rye and crimson clover grow in the winter between summer cash crops. Cow-peas cannot do this, but I know that they pay in the way of soil improvement, and all that is gotten by harvesting with hogs may be accounted clear money from the land while it is being improved for the next season's regular cropping.

\*\*\*

**THE SOIL FOR PEAS.**—It is often said that cow-peas will grow in the poorest soil, and this is one of the advantages insisted upon. Well, they will make some growth on very poor land, but not sufficient growth to build up the soil rapidly. Such land is usually deficient in phosphoric acid, and the best plan is to fertilize for peas by applying an acid phosphate. That helps the peas to help themselves. Again, these peas will not do well on cold or wet soils. They must have warmth. But where the soil favors this crop adds rapidly to the store of available plant-food. It adds nitrogen to the soil just as clover does, and it improves the physical condition. The time of seeding enables one to kill out noxious weeds. For soil renovation, if a few summer months are available, no plant of which I have knowledge surpasses the cow-pea wherever it thrives. The same season it may be followed with rye as a winter cover crop, and the land is then put into prime condition for breaking for a spring crop.

**COW-PEAS AND CANADA PEAS.**—These two kinds of crops have been confused in the minds of many readers of farm papers. They are not the same, nor at all alike. The Canada pea is a true pea, requiring early planting, and is usually seeded with oats for feed. The cow-pea is a tender bean, unable to stand early planting, and requiring a warm soil and lots of heat. The first thrives in the North; the other is very unlike in character and thrives in the South. One is seeded as soon as the frost is out of the ground, and is primarily for feed; the other is seeded after all danger of frosts is past, and is primarily for renovation of the soil.

\*\*\*

**SEEDING TO COW-PEAS.**—The ground should be broken the last of May and fitted for seeding. If the soil is sandy or loamy very little work in fitting is required. Some growers sow the seed broadcast on the fresh-plowed ground before harrowing, and then use the harrow for covering the seed. If it is weedy meadow or rye sod that has been broken, or if there are some clods, it is my experience that good preparation of the seed-bed pays. A good harrow and roller do the work, and then the seeding is best done with a grain-drill. The Black is the variety for a belt one hundred miles or so north of the Ohio river. Farther north, if one desires to experiment, a variety sold by seedsmen as Warren's Extra Early is surer to mature. Some of the best Southern varieties will not mature in the North, but the Black makes a heavy growth, and usually matures in the belt mentioned. This year the seed is high-priced, I understand. Usually those who do not save seed by hand-picking have to pay \$1.10 to \$1.25 a bushel. Six pecks of seed to the acre is about right, though some growers use a less amount in good soil.

DAVID.

### A CONVENIENT RAIL FENCE

When a farmer has a lot of old rail fences going to rack he will find the fence shown in the illustration the cheapest one he can build. Set posts six inches closer together than the rails are long; take two pieces of ordinary fencing-wire, each about six feet long, and place on sides of first two posts, having wire on second post on opposite side to wire on first post; fasten these wires to the post at or near the ground. Now place a rail between wires and post, drawing wire up tightly over rail and stapling just above rail with long staple, doing same at both ends; put on another rail as before, and continue till top of posts is reached, which completes

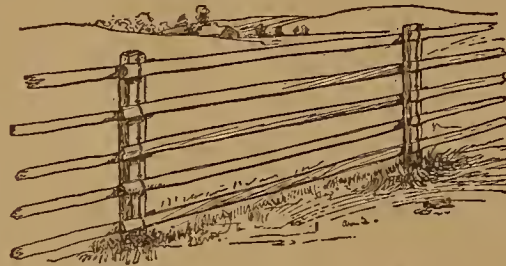

A CONVENIENT RAIL FENCE

the first panel. The other panels are made in the same way, taking care not to have both ends of panel on same side of posts, but run alternately as started. The illustration shows the way rails are stapled to posts and the manner of running panels. As the rails when put on posts in this way do not touch each other they will last longer than when put on any other way; and I like this method of making use of old rails very well, for by setting posts and using a little wire a good fence can be made from a very poor one. Build six to eight rails high. Should a post rot off any time set another near it and fasten rails as before. J. G. ALLSHOUSE.

2

### ANGORA GOATS

The Angora industry has been started in the United States to stay, at least in all rocky, hilly and brushy localities. We have a great deal of such range in Texas that is excellent for these goats, while it would be almost worthless for other kinds of stock.

Where only a few are kept they generally take care of themselves and soon increase to a good flock. There are, perhaps, no other animals that love their homes as well as Angoras. They will come home regularly about half an hour before sundown, except when disturbed by dogs or wolves. The safest way, however, is to keep Angoras in a wolf-proof pasture. I use ten of the best barbed steel wires for a pasture fence. The posts should be not more than twenty feet apart. All the wires should be well stapled to the posts, also to three stays between the posts. The spaces under and between the wires should be, counting from the ground upward, 1, 3½, 3½, 3½, 4, 4½, 5, 5½, 6 and 7 inches, forty-

eight inches in all. The wires should always be kept very tight. If wolves scratch through under the lowest wire, where the ground is soft, you should put good-sized steel traps there on each side of the fence; the No. 4 steel traps are large enough for wolves. We do not fasten the wolf-traps, but generally fasten three traps together. By this the wolf often gets more than one foot into a trap. If you fasten the traps the wolf is apt to break loose; but if he can drag away the traps he will go only about three hundred yards and hide in a thicket, where your dogs will find him and you can shoot him. Common dogs soon learn to follow the trail of the wolf, and it is fine sport to kill the wolves in this way. Since we have been using wolf-traps we have quit using strychnine, and find that traps are better. As soon as we get rid of the wolves we can raise sheep and goats and hogs much cheaper. If prices for wire go down again to two and one half cents we can also build safe pasture fences cheaply.

In keeping Angora goats for profit the main thing you need is a hilly range with plenty of brush and various kinds of weeds; grass is not needed. Wherever you keep these goats in large numbers for several years the weeds and all undergrowth of brush will disappear and the range will be improved for cattle and other stock.

The meat of these goats is about the finest in the world. Everybody likes it. It tastes just like fat venison. The wool or hair brings from thirty to forty-five cents a pound in New York. They should be shorn twice a year—in March and in September. The bucks should be turned into the flock about the twentieth of October, so the kids will begin to come about the twentieth of March, and shearing should be completed before the kidding-time begins. The only things that trouble these goats are the screw-worm and the lice. Against the lice they should be dipped, as sheep are dipped against scab; and the screw-worm bothers goats no more than it does sheep or other stock.

The Angora-goat business is increasing very rapidly all over the United States, and it is quite difficult to get goats for breeding; even the common Mexican goats are getting very scarce. If Mexican goats are used for starting a flock of grades you should use only pure white, short-haired, smooth-haired nannies. By this you can have a nice bunch of grades that can be sheared in three or four years. Of course, you should use the finest Angora bucks that can be got at reasonable prices. After your grades are of the third or fourth cross you can have fine shearing-goats. It looks like Texas is the very best country for these goats. They live about twice as long as sheep, and appear to be always in good health. H. T. FUCHS.

2

### PREVENTING FLIES

One of the greatest nuisances about a farm is the pest of flies in the summer and fall. It would be hard to estimate the loss occasioned by them every year about the barns, dairy and feed-lots. No cow can do herself justice where she is forced to keep up a continued battle with a swarm of flies from daylight until dark. Worrying at the flies is more wearing on a team than hard labor. The cause of pastured and fattening stock losing flesh in the summer is the flies. As with most evils, the best cure is prevention. To prevent the pest one must remove their breeding-ground, which is the filth and trash about the premises. It is the case on most farms that the manure-heaps are allowed to accumulate during the summer and the yards to go uncleaned. These furnish the best of breeding-places for the flies. Swill barrels and buckets, too, are never washed out, but are allowed to sour and become incrustated with dirt, another source of flies. In feeding the hogs and calves milk and slop are spilled about the troughs and barrels day after day. The ground thus treated soon becomes a hot-bed for the eggs, which will hatch and feed there. Open closets and uncovered drains are another source, as is any place where there is decayed matter or filth for the maggots to thrive upon after hatching. Flies are far more of a local pest than most people imagine. A farm-house whose grounds are kept clean and whose back yard is free from refuse, slops, etc., will be little troubled with flies. Stock kept in a clean stable or lot will be less troubled than the animals of the untidy, shiftless farmer. Cleanliness and flies do not thrive together.

J. L. IRWIN.

2

### OUR STONE-BOAT

Where we have to deal with side-hills, and where land is very stony, a boat on runners works very satisfactorily. I have just made

one for a neighbor, and there may be some who wish to profit by the experience.

The size of a boat for our hilly lands need not be over three by eight or nine feet. A mistake is sometimes made choosing too heavy material. I would rather make another new light boat after the first one was worn out than to handle over and over again, for several years, perhaps, the extra amount of timber that it is necessary to put into a boat to make it last a year or two longer. Life is too short to waste strength that way. I want to use the more porous or light timbers, such as whitewood, chestnut or pine, for floor, and those not over one and one half inches thick. The railing I make of the same material two and one half inches square. This is high

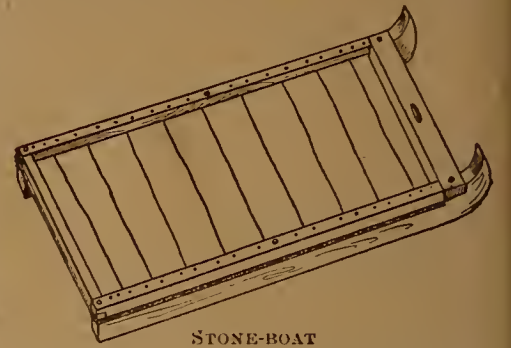

STONE-BOAT

enough. The higher they are the more work it is to load on heavy stones requiring rolling. For the same reason I don't want the runners to be higher than is consistent with strength; I regard a thickness of four inches sufficient, but the kind of timber should be white oak. It will wear and not rot out very soon. A natural crook is to be preferred. When such a runner is partly worn off strips of oak board may be nailed under for shoes, and when these are gone others again may be nailed on if the boat is still good.

The narrower the stone-boat, the easier, of course, it may be tipped over with its load of stones. On our hillsides we can often unload easily and quickly thus, and so I would not make a boat too wide.

It is well to use six bolts to bolt the runners, plank, or floor, and the railing together solidly, using one bolt at each corner and one bolt in the middle on each side. The bolt-heads must necessarily be let into the runner about one and one half inches from the bottom. Aside from these six bolts I use spikes to fasten the floor to the runners and the railing to the boat. Thus a boat can be made quickly. To draw by, either a hole may be mortised through the front plank large enough to admit a piece of chain, or a large clevis or an iron hook may be bolted on.

F. GREINER.

2

### FAILURES WITH ALFALFA

In some sections of the West where alfalfa could be easily grown it has not become popular because, the farmers say, it will not succeed on account of being choked out by weeds or of failing to give a good second cutting, with no third cutting at all.

From a study of the failures in growing this crop it seems that the method of growing is at fault. As a general rule the ground is well prepared in the spring, the seed sown at once, and a good, promising stand obtained; but in the autumn what alfalfa there is hides among the fox-tail and other weeds. Few or no plants appear the following spring, and the farmer, after perhaps another trial or two, gives up.

If this method were abandoned for the following there would probably be more fields planted to this crop. Prepare the land (five acres is a convenient area) a year or two previous to sowing by growing well-tilled corn upon it; in the spring sow an early-maturing crop, such as early planted soy-beans or oats; harrow the ground after this is off each two weeks until the autumn rains commence. Plowing will not be necessary unless the stubble is dense. This harrowing will improve the soil and kill several crops of weeds. After the ground has become wet sow the alfalfa. If it does not become wet postpone seeding until the spring. The best method of seeding is to cross-drill, the seed being mixed with an equal quantity of sand, bran or other substance, or the drill being set so as to sow only half the quantity at each operation. In this way half the seed is sown across the other half. As soon as the plants reach a height of six inches they should be mowed. This, if practised two or three times, will kill weeds and help the alfalfa. It should be done, weeds or no weeds.

Don't cut alfalfa as you would clover, after full bloom. Cut before the maximum bloom, and for the first spring cutting even earlier. This will insure heavier late cuttings. As final cautions, avoid loose, dry ground, let the soil settle and become moist, avoid late cuttings, and avoid pasturing until the third year.

M. G. KAINS.



## NOTES FROM GARDEN AND FIELD

**PEANUTS AT THE NORTH.**—R. E. S., of Royalton, Vermont, asks me about the culture of peanuts. He has received a package from an Illinois seed-house, but no directions for sowing the same. I suppose that this seed is of the newer "Spanish" variety, which was introduced as a novelty some ten years ago, and is just the one which the Northern grower should try. With us it is out of the question to grow the ordinary large peanut grown in Virginia and other Southern states. We cannot hope to ripen that variety here, and even the earlier Spanish sort we can plant with any kind of hope for success only on very warm soil, such as a sandy loam, that must contain a good portion of lime and be well enriched with old manure. This Spanish sort gives a very small pod, but the pod is well filled and the nut of fine quality. The nuts grow in a rather compact cluster near the main stalk. I consider this crop quite an interesting one, even where we have some difficulty in ripening it, and for this reason alone I would recommend it to the attention of my friends at the North. It is not necessary to shell the nuts for planting. Make the rows three feet apart for field cultivation, although you can have them a little nearer where they are worked mostly by hand. Plant a pod about every foot in the row, an inch or so deep, and keep well cultivated until the plants begin to bloom and set the nuts. The little branchlets enter the ground, which should be kept loose and a little drawn up to the plant for the purpose, and there form the pods. When the plant has reached the proper stage of maturity, or before the first killing frost, it is to be pulled up, the pods all adhering to it, and it must then be dried off and the pods pulled off and put away. This is about all there is to it.

\*\*\*

**BEAN-WEEVIL.**—A reader in Iowa writes that for the last two years he has found a bug or weevil in both his Lima and field beans, the seed being saved from the first planting. He is told by one of his neighbors, a market-gardener, that late-planted beans will be free of this pest. It is true that beans planted late often, if not usually, escape the attacks of weevils. So you can raise your seed-beans by planting rather late, say June 20th if that is early enough to bring the crop to maturity. Still there is no use of running any risk of propagating the pest. It is a simple matter to free seed-beans from the weevil, which may be present in them in the pupa state at the time the beans are gathered. Exposure to heat, say one hundred and forty degrees Fahrenheit, for an hour or two will kill the weevil inside of the bean without injuring the bean itself for seed. Great care and watchfulness, however, are always necessary to prevent overheating, which might not only kill the weevil, but the bean germ also. Exposure to the fumes of bisulphid of carbon is undoubtedly the safer plan, and it should be practised not only with all beans intended for seed, but with all peas as well. And if beans or peas are to be kept for some time after harvesting for table purposes it is far better to have them subjected to the same treatment likewise. Many of our seedsmen still send out weevil-infested seed. This should not be. There is no necessity for it. Most of the seedsmen buy all the peas they send out to their customers. They should compel the grower to have all peas fumigated in a proper manner before delivery. Or if they cannot make such a bargain with the grower, they should have the peas delivered shortly after harvest, in order to be able to subject them to the bisulphid-of-carbon treatment themselves before the insects have had much chance to do damage.

\*\*\*

**GROWING LENTILS.**—I have two inquiries—one from New York and one from Maine—about lentils. The writers want to know whether this crop could be grown in the states named, about varieties, where seed could be procured, and how the crop is to be grown. I used to like lentil soup in my younger days, but have not had any on my table for many years, although I see them offered for sale in some of the large grocery-stores of Buffalo right along. The plant is a leguminous weed, I believe, and found wild as well as in cultivation in Europe. I have seen at least two varieties, the seed of one being several times as large as that of the other. I have had no experience with lentils as a crop, but would sow it like ordinary grain, broadcast. Possibly one or

the other of our readers will volunteer to give us more details of the requirements of the crop and of its cultivation. I believe that lentils are the dish of which Jacob was so fond that he sold his birthright to Esau for a mess of it (mess of pottage).

\*\*\*

**BEST LATE POTATOES.**—Mrs. C. H. T., of Edgewood, Iowa, wants me to name the best two kinds of late potatoes. She wants them of medium size, smooth skin, dry and mealy, yet not easily boiling to pieces. I do not like to recommend any kind of vegetable as absolutely the best. I find frequently that what suits one does not please the other, and that locality and soil sometimes have much to do with the most profitable selection of varieties. I will say, however, that I like the Carmans (Carman No. 1 and No. 3) about as well as anything I now have in the late-potato line. The newer Commercial is also good and productive, although not as smooth as I would like. The Carmans are very smooth, but inclined to run large. For a potato of exceptionally good quality, of medium size, medium season, very smooth and moderately productive under good treatment, I think the Freeman will be hard to beat. I have secured a new supply of it, having missed it in my garden and on my table for several seasons.

\*\*\*

**HILL-MANURING FOR VINES.**—T. S. C., of Chicago, Ill., finds good manure hard to get, and proposes to mix his fresh hen manure with soil, and after drying, to mix and roll it thoroughly so as to get it all fine, and then put this in the hills where he intends to plant cucumber and melon vines, tomatoes, etc. He also proposes to dissolve some of this mixture in water, and apply this to the growing plants. The plan is all right. The big squash (weighing three hundred and sixty-five pounds) exhibited at the World's Fair in Chicago in 1893 was grown in some such way. An excavation had been made for each hill a foot or eighteen inches deep and six to ten feet in diameter. The soil thrown out was thoroughly mixed with a few wheelbarrow-loads of just such compost as our Chicago friend proposes to make, and this then filled into the excavation again. It should be said, however, that the soil should be well firmed after being put back in the hill before the seed is planted. Watering, or soaking rather, once a week or so in a dry time with the manure-water made as suggested will probably show excellent results. Our friend also asks whether wood ashes is good to put on the vines to keep the bugs off. I have never noticed such effect of wood-ashes applications. Plaster, as well as air-slaked lime, is often used for that purpose. I am a little afraid of lime, however, and have often seen bad effects from it, the plants being scorched by the lime and injured worse than they were by the beetles.

T. GREINER.

### INQUIRIES ANSWERED

BY T. GREINER

**Cucumber Blight and Bugs.**—B. R., Broad Ford, Pa., writes: "Mine and other people's cucumber and melon vines here have all died at once, about the first of September, for the last two years. They look as if they had been frosted. We know of no remedy for the striped bug except to kill them."

**REPLY:**—The blight which attacks cucumber and melon vines about the time mentioned is a serious trouble not only in Pennsylvania, but all over the country. The bugs must be given a share of the blame. At least, if we could keep our plants entirely free and unweakened from bug attacks they would not be so liable to take the blight. So our first aim should be to keep the bugs off either by hand-picking, pieces of sticky fly-paper placed about the hills, by tobacco and hone-dust, or by spraying with the poisoned Bordeaux mixture. The last-named can always be used to advantage, and will in many cases assist in keeping the plants in health.

**Nitrogen and Ammonia.**—C. R. L., Manchester, Ohio, writes: "Please give the opinion of your chemist as to the difference of nitrate of soda as nitrogen or ammonia. Are they the same except in strength? Also tell about saltpeter as a fertilizing potash."

**REPLY:**—Pure nitrate of soda is a compound of one atom (23 weight units) of sodium, one atom (14 weight units) of nitrogen and three atoms (16 weight units or 48) of oxygen. The nitrogen in this form (equal to 16.47 per cent of nitrate of soda) appears as nitric acid, and in this form is just right for the use of plants. There is no ammonia in nitrate of soda. Ammonia is a compound of three atoms (3 weight units) of hydrogen and one atom (14 weight units) of nitrogen. In this form the nitrogen will first have to be converted into nitrate acid before it is fit for plant-food. A pound of ammonia contains only 14-17 of a pound of nitrogen. Saltpeter is a nitrate of potash, containing 39.1 weight units of potassium, 14 of nitrogen and 48 of oxygen, or in its pure state over 14 per cent of nitrogen and 40 per cent of potash.

## ORCHARD AND SMALL FRUITS

CONDUCTED BY SAMUEL B. GREEN

### PEACH-LEAF CURL

The following article is taken from a Cornell University bulletin on leaf-curl in peaches. The same treatment will probably prevent the formation of plum-pockets:

There is no good reason for giving up the Elberta or any other variety of peach sensitive to leaf-curl, as this disease can be controlled by spraying at trifling expense.

Of the three substances employed as fungicides in these experiments the Bordeaux mixture is the most useful; and, though several different strengths of this mixture have been found nearly equal in efficiency the past season, for the early spraying a strong solution is recommended. When Bordeaux of good strength is used early, and a season of warm, dry weather follows, continuing as late as the middle of May, a second spraying is not profitable. But if the weather is cold and wet it is well to spray again with Bordeaux after the petals fall, using only two pounds of copper sulphate (with excess of lime) to fifty gallons of water; for, notwithstanding some statements to the contrary, the foliage of the peach seems sensitive to stronger solutions.

The treatment, then, for the prevention of peach-leaf curl is briefly as follows:

1. Spray with Bordeaux consisting of six pounds of copper sulphate, four pounds of good quicklime and fifty gallons of water about the first of April, when the buds are beginning to swell.

2. Spray again when the petals have fallen with Bordeaux consisting of two pounds of copper sulphate, two pounds of good quicklime and fifty gallons of water. If the weather of April and early May is warm and dry this second spraying may be omitted.

Lime or copper sulphate along with water have been almost as effective as Bordeaux the past season when used for the first spraying and followed later by Bordeaux, but their effects are not so lasting, particularly in rainy weather, and whether the season is favorable or unfavorable, the second spraying with Bordeaux should not be omitted when lime or copper sulphate are used alone for the first.

**HOW TO MAKE THE BORDEAUX.**—Prepare a stock solution by suspending twenty-five pounds of copper sulphate in a coarse sack in twenty-five gallons of water for a day or more until completely dissolved. To make fifty gallons of strong Bordeaux for the early spraying, take six gallons of the stock solution and dilute it with nineteen gallons of water. Weigh out four pounds of the best quicklime, slake it slowly, dilute to twenty-five gallons, and strain through a metallic sieve into the copper-sulphate solution while the latter is being stirred.

To prepare fifty gallons of the weak Bordeaux for the late spraying, proceed in the same manner, using two gallons of the stock solution of copper sulphate, two pounds of quicklime and forty-eight gallons of water.

### INQUIRIES ANSWERED

**Kerosene-and-water Spray.**—A. W., Cleon, Mich. The best general remedy for worms that attack the foliage of fruit-trees is to spray the foliage with Paris green and water at the rate of one pound to two hundred gallons. When kerosene and water are used as an insecticide it must be used in a specially prepared pump which will mix the kerosene and water just as they leave the nozzle. It cannot be successfully used in a common spray-pump.

**Bark Splitting.**—H. H., Clarksdale, Iowa. I do not know why the bark on your fruit-trees is splitting around the bottom, unless it is due to some winter injury. I can easily account for it, however, if it is only on the south side, as in that case I should think it due to sun-scald, which is a common source of injury in your section. White-washing trees does no harm; in fact, I regard it as beneficial rather than injurious when applied to the trunks of trees, and sometimes helpful in keeping out horers.

**Trimming Peach-trees.**—M. H. P., Spring Lake, N. Y. In trimming peach-trees some regard should be paid to form, and any awkward branches should be shortened or removed entirely. As a rule, however, they take on a very uniform shape and are easily kept in condition by shortening the new growth from one third to one half, which should be done in the latter part of the winter or early in the spring before the growth starts. The principal reason for doing this each year is to keep the tree in compact form and to thin out the fruit-huds, which are produced in such abundance that if not thinned out the trees are very liable to overbear; and even where this kind of pruning is practised it is generally advisable to thin the fruit.

**Codling-moth.**—W. W., St. Paul, Minn. Your crab-apples are undoubtedly injured by codling-moth larva. The eggs of this insect are laid in the apex of the apple soon after the flowers fall and before the apple has turned downward. The remedy is spraying the trees with Paris green and water at the rate of one pound of best quality Paris green to two hundred gallons of water. For applying this you should have a regular spray-pump, but as you have only a few trees you can perhaps get along with a common garden-syringe.

**Pruning Soft Maples.**—R. W. S., Homewood, Ill. Soft maple is so very hardy that light pruning may be done to it at any time without seriously injuring it. The time when it is most liable to be hurt, however, is just as the buds are expanding in the spring, at which time the sap flows freely. After the leaves are pretty well out they can be pruned without injury. If your trees need pruning it would be best to wait until early in June before pruning them. They may also be pruned in the autumn or during mild days in winter.

**Spraying Plum-trees.**—G. S., St. Marys, Ohio, writes: "When is the best time to spray plum-trees, and what is the best mixture?"

**REPLY:**—There is no mixture that is a sure remedy for spraying fruits, and if you are going to spray your plum-trees you should know definitely what you are to spray for. It is with plums as with other fruits. There are several diseases or insects which attack them, and each of these requires different treatment. If your trouble is that your plums are stung by curculio and drop to the ground, then your best remedy is not to spray, but to jar the trees early in the morning, beginning as soon as the flowers fall, and gather the beetles on sheets which have previously been laid under the tree. These beetles should be destroyed, as they are the mature insect which lays the egg which hatches into the worm and destroys the fruit.

**Spraying Fruit-trees—Kerosene and Water.**—A. S., Odon, Ind. In order to spray successfully you must know definitely what you are to spray for. In the case of plum-trees I think you will find my answer to G. S. will cover your conditions.—In the case of apple-trees I would suggest that you spray the trees just after the flowers fall and before the apples turn down with Paris green and water in the ratio of one pound of Paris green to two hundred gallons of water. Kerosene and water will not mix permanently, and in order to use them as an insecticide on growing plants a specially prepared pump must be used for the purpose, and it is of no special advantage in spraying apple and plum trees under ordinary conditions except when they are infested with lice. If you have not a specially prepared pump for this purpose I would suggest that you use tobacco-water for the tree-lice, instead of kerosene, making it from tobacco-stems and about the color of strong tea.

**Grafting.**—J. A. L., Fine, N. Y. Ordinary grafting of trees is preferably done in the spring—in the case of apples just as buds begin to open; in the case of plums before the buds have started. In either case the scions which are inserted should be dormant. In the case of the apple and the pear the scions should preferably be cut in the fall, as they are liable to injury during the winter. In the case of the plum it is preferable to cut the scions in the spring, as they are rather difficult to carry over winter in good shape. If, however, in the case of the apple you have failed to cut the scions in the fall, you may have very good success with spring-cut scions. Grafting-wax is made by melting together two pounds of beeswax, four pounds of resin and one pound of tallow. When it is all melted it should be poured into cold water and pulled in the same way as molasses-taffy until it is light-colored. It can then be rolled into balls for use out of doors as needed. Wax that is pulled in this way is tougher than that which has not been so treated, and is preferred by most nurserymen, although some very successful propagators apply the warm wax with a brush without bothering to first pull it.

**Picking and Crating Strawberries.**—J. H. M., Osage, Okla. In handling strawberries for marketing the first thing to bear in mind is that you must adapt yourself to the market in which you intend to sell your fruit. Throughout most of the Mississippi valley the package demanded is what is known as the "gift package," containing from sixteen to twenty-four quart boxes. The berries should be picked daily in warm weather, and in cold weather the bed should not go more than two days without picking. Great care should be taken not to put any overripe berries in the boxes; in fact, it is far better to have the berries partly green than to have them over-ripe, as one overripe berry in a box will very likely result in the loss of all that are with it. Great care should also be taken to keep the berries clean and free from dirt. To this end it is very desirable to mulch them so that the dirt will not spatter upon them in case of rains. The berries should be picked with a portion of the stem, and the hulls should never be broken off. Do not put in small or deformed berries, for they will not pay for shipping, and if they are mixed with the good berries they reduce their price very considerably. The box should be well filled, and care should be taken that the berries on the top of the box are fully as good as at least as the berries in any part of it; in fact, it is a good plan to pick off any poor berries that may be on top of the box and replace them with some that are extra good. The difference, however, between the top berries and those below should not be sufficiently evident so as to be deceptive. In keeping track of the pickers a number of systems are used. Perhaps the arrangement by which each picker has a card which is punched for every case of berries picked is as good as any, but it matters comparatively little what system is followed in regard to this, provided the work is well systematized so that the accounts are carefully kept. The matter of securing a good market is very important and should be carefully considered.



LEVEL CULTIVATION AND DUST MULCH

I wish to talk of the importance of so planting seed in the ground as to admit of level cultivation throughout the season. All plants which under the old system required "hilling up" should be started in trenches, the depth varying with the different sorts, so that when summer tillage is fairly under way the whole surface of the garden or field is as nearly as possible flat; thus the rake or cultivator can be brought close to the stalk of each plant. It is well understood nowadays that many lateral roots of certain crops—notably corn—grow so near the surface that they are seriously injured by the plow and hoe as they were formerly used. But this is not the subject of my present communication, which is about the conservation of moisture by surface cultivation. Readers of the FARM AND FIRESIDE are familiar with the arguments, but results of personal experience, recorded by a careful observer, are never without value if on a subject of general importance.

I use my garden somewhat as an experiment station. I test theories, and am nearly as well satisfied by failure as success; a false theory cannot be exploded too promptly. I have tested the theory of dust mulch for three seasons under conditions which made the test a severe one. The garden is on the crown of a small hill, the ground sloping away in three directions. It is very hot when the sunshine pours upon it, and there were days last summer when the leaves of all the succulent plants lay flat upon the ground, and even those of the bush-beans hung wilted on their stalks; yet with an abundant supply of water having a strong pressure, and hose with which I could reach all parts of the garden, not a pint of water was used throughout that almost rainless summer. I had pursued the same course the two previous seasons to some extent, but my resolution had given way at times, with not beneficial results, I thought. Last summer I stood firm, and there was not a day when the roots of the plants were not in damp soil, and not a crop suffered serious disaster.

I had had a lesson which prepared me for dust mulch. The first season I worked my present garden I used the hose liberally, causing the ground to be well wetted when there was no rain. This required a good deal of time—for which I had to pay—to keep the ground moist; but the garden looked well and gave good promise. I was called away from home two weeks in July. The boy who was to sprinkle the garden did "sprinkle" it and nothing more, and I found everything in it dead or nearly so. It did not recover. Examination showed that the constant wetting of the top soil had called out surface roots; nothing had penetrated to any considerable depth, and two weeks of neglect had brought inevitable ruin. I had already come to believe in dust mulch when water was not available; I then came to believe in it without reservation.

I have already told, in the FARM AND FIRESIDE of February 1st, how I plant tomatoes. These are given an extra depth, because the tomato sends out roots wherever the vine touches the earth. Other vegetables I plant, or transplant, in trenches of depth just sufficient so that they will be properly hilled up when the trenches are filled and the garden is level. Then with rake or cultivator I keep the soil to the depth of one or two inches finely pulverized between the rows, and, where possible, between the plants in the row. This dust is a perfect mulch. Moisture will rise through the soil until it reaches it, but will not evaporate through it to any considerable extent; no more will be lost in the hours of sunshine than will be replaced in the night. I have found that there is stored in the earth sufficient moisture to provide a constant supply, provided evaporation is checked a short distance from the surface. There was no time during the drought of last summer—and it was a wonderfully dry summer in the East—when with the toe of my shoe I could not find moisture. This was a matter of astonishment to visitors when all the soil in the garden glowed white in the blazing sun.

Dust mulch requires much less labor than the hose or watering-pot, even when these can be readily used, for mulch remains intact except when it rains or showers or when trodden; then the rake or cultivator must be applied as soon as possible after the soil gets into suitable condition. If this is delayed rain, unless very heavy, will prove an actual injury. One day last summer there was a shower of just sufficient duration to beat down and saturate the mulch; a day passed without proper attention, and the next day the moisture-line was an inch lower than it had been. The effect of even a slight compacting of the soil is apparent in the early morning. There were many weeks in which

the track of a cat could be followed by the dark spots amid the surrounding whiteness, showing that the moisture had risen in her footsteps. So important did I come to consider the inviolableness of the mulch that whenever I entered the garden to gather vegetables, or for any other purpose, I raked out my tracks as carefully as if to conceal a depredation.

The entire absence of weeds is one of the by-products of this system of culture, but of minor importance to my mind. It is rather pleasant, though, to look over even a small garden and see no sign of unproductive vegetation. The owner gets credit, too, for industry which he does not deserve, but which it is pleasant to receive. "Not a weed!" exclaimed a friend; "how your back must have ached!" In fact, I hadn't stooped after planting-time.

As I remarked to the careful reader of the FARM AND FIRESIDE, this is an old, old story. I was gratified last June, while passing through Pennsylvania from Philadelphia to Harrisburg, to see the dust-mulch theory applied in practice in that splendid farming region. The weather was very hot, and the yellow soil seemed hopelessly dry; but between the long rows of corn, only showing an inch or two aboveground, were cultivators of all sorts throwing up clouds of dust. A few days later I returned in the wake of heavy showers; an increased number of men were toiling over the same fields, pulverizing the moist earth before it should have time to bake. I concluded that, wet or dry, there would be little shortage of corn in those valleys, and I realized as never before the incalculable value of experimental farming and the broad influence of the intelligently conducted agricultural press.

S. CUSHMAN CALDWELL.

A GOOD WORD FOR SKUNKS

The farmer has no animal of its size that is of greater benefit to him than the skunk in the way of killing field-mice and insects of various kinds, especially the white grub that is so destructive to grass and corn in some localities. Skunks will gather more worms from tobacco-plants than anything else I ever saw. I have protected the little animals on my farm for the past five years. Two years ago I had out five acres of tobacco, and gathered without help what worms the skunks did not find. I could not have done this if the skunks had not had free access to the field.

Some farmers say skunks kill chickens and are therefore a nuisance. How about the mink, opossum, weasel and the rat, especially the rat? If the hen-house is rat-proof, as it should be, skunks will never bother chickens. GEORGE Q. GESAMAN.

CORRESPONDENCE

FROM GEORGIA.—Another big cotton-mill is to be erected here, capital one hundred thousand dollars. Hart county affords excellent water-power. Good land sells for from \$8 to \$12 an acre. We have the best schools in northeast Georgia. Harkwell, population 2,700, is one of the most healthful towns in the state. B. B. W. Harkwell, Ga.

FROM COLORADO.—The first season's run of the Grand Junction sugar-factory gave two million pounds of granulated sugar. As the capacity of the plant is several times that, arrangements are being made to bring in colonies of Germans and Quakers, aggregating eight hundred families, to grow sugar-beets this year. Free land and free water are offered as inducements. A large smelter is to be constructed soon near Grand Junction. Prices of all property are advancing. Realty is still low, but beginning to feel the effects of improved conditions. Our population is mostly American-born, and I should like to see our native-born farmers secure homes in Grand valley while land may yet be had at reasonable prices. Population of Grand Junction is four thousand. Grand valley is fifteen by thirty miles in extent. C. W. S. Grand Junction, Col.

FROM KANSAS.—Washington county, on the north line, about one hundred miles west of the Missouri river, is in the corn belt. Our country is very rolling, and has no timber except along the streams. We have a rich black soil of a clayey nature, underlaid by a hard clay subsoil that is almost impervious to water. Corn, Kafir-corn, wheat, oats and rye are our principal grain crops. Prairie-grass, millet, cane (sowed) and Kafir-corn (sowed) are the hay and fodder crops; some corn is cut for fodder. The rainfall ranges from six to twenty-six inches a year. I have lived here since 1882, and have seen but three failures in corn. Kafir-corn is the surest crop that we can raise, and is very valuable both for grain and fodder. It is a crop that will stand more dry weather than any other crop we can raise. Corn is almost wholly planted by listing, a method that Eastern farmers would laugh at. A. F. C. Kara, Kansas.

- ARMSTRONG & McKEEVEY Pittsburgh.
- BEYMER-BAUMANN Pittsburgh.
- DAVIS-CHAMBERS Pittsburgh.
- FAHNESTOCK Pittsburgh.
- ANCHOR Pittsburgh.
- ECKSTEIN Cincinnati.
- ATLANTIC } New York.
- BRADLEY } New York.
- BROOKLYN } New York.
- JEWETT } New York.
- ULSTER } New York.
- UNION } New York.
- SOUTHERN } Chicago.
- SHIPMAN } Chicago.
- COLLIER } Chicago.
- MISSOURI } St. Louis.
- RED SEAL } St. Louis.
- SOUTHERN } St. Louis.
- JOHN T. LEWIS & BROS CO Philadelphia.
- MOBLEY Cleveland.
- SALEM Salem, Mass.
- CORNELL Buffalo.
- KENTUCKY Louisville.

THE brands of White Lead named in margin are genuine. They are and have been the standard for years. They are manufactured by the "old Dutch process," and by a company which is responsible. Unlike the so-called White Leads (mixtures of Zinc, Barytes, etc.), these brands correctly represent the contents of the packages.



FREE For colors use National Lead Company's Pure White Lead Tinting Colors. Any shade desired is readily obtained. Pamphlet giving full information and showing samples of Colors, also pamphlet entitled "Uncle Sam's Experience With Paints" forwarded upon application.

National Lead Co., 100 William Street, New York.

**IT'S WORTH YOUR WHILE....**  
to investigate the difference between our prices and those of agents and dealers for the same grade of work.

**...WE DO NOT SELL...**  
through agents or dealers, therefore we do not have them to protect, and in making our prices are enabled to figure them as low as the grade of work we manufacture can be sold. We save you the profits that are added between the manufacturer and the consumer, by selling direct to you from our factory. This has been our method of selling for the past twenty-seven years, and we are today the largest manufacturers of vehicles and harness in the world selling \$70. We guarantee it as good as others sell for \$30 to \$40 more than our price.

No. 48—Single Strap Collar and Harness. Price vehicles and 65 styles of harness and ship anywhere with tickel trimmings, \$11. for examination, guaranteeing safe arrival. Send for free catalogue showing all of our different styles. Good as sells for \$16.

No. 725—Stanope. Price complete with shafts \$70. We guarantee it as good as others sell for \$30 to \$40 more than our price.

ELKHART CARRIAGE & HARNESS MANUFACTURING CO., Elkhart, Indiana.

**DEAR MOTHERS**

Is this Elegant Sugar-Shell WORTH ASKING FOR?

Best sterling silver plate—beautifully engraved. Full size—much larger than illustration. This or any other of our 40-cent sugar-shells absolutely free to every mother in the United States. Please write us a letter to-day, stating that it is your first request for any of our souvenir gifts, and we'll send you illustrations of our entire line. Select any 40-cent sugar-shell, and we'll send it free—a gift from us—absolutely free of charge. Send your own name only. This is too expensive a gift to send to persons who don't ask for it themselves. But one gift to a family and none to children. Our object in making this remarkable offer is to get a sample of Quaker Valley Silverware into every home in the land. Please write to-day. Don't put it off.

QUAKER VALLEY MFG. CO., 309 WEST HARRISON STREET, CHICAGO, ILL.

STANDS A WORLD OF WEAR AND TEAR

**Remington** Standard Typewriter.

WYCKOFF, SEAMANS & BENEDICT, 327 Broadway, N. Y.

**BULL-STRONG**

Seven styles. Any height desired. Made of Coiled Spring Steel Wire, galvanized. The coil makes it self-regulating. It's **CHICKEN-TIGHT**

Our Prices will surprise you. We sell direct to the farmer at lowest wholesale **Anti-Trust Prices** as we belong to no Combination or Trust. Catalogue and prices free for the asking.

COILED SPRING FENCE CO., Box 18 Winchester, Indiana.

Soon Saves its Cost. **A 12-Year Old Boy**

A Labor Saver. can do more and better work, either in the field or garden, with the **HAND CULTIVATOR**

than three men can do with common hoes. Plows, hoes, cultivators—stride or between rows. If no agent in your town send \$1.35 for sample delivered and terms to agents. Ulrich Mfg. Co., 43 River St., Rock Falls, Ill.

No. 0 **Kitchen Cabinet**

WRITE FOR CIRCULAR AND PRICE. MANUFACTURED ONLY BY J. A. KELLY & BROS. Clinton, Iowa

**LIN-SEED OIL** with White Lead makes paint last for years on house, barn or fence. Mixed paints are doubtful quality; some are good and many are VERY BAD. For Lined Oil and White Lead or Oil Meal, ask for Thompson's, or get circulars and prices. THOMPSON & CO., 509 W. Diamond St., Allegheny, Pa.

**ALUMINUM CREAM SEPARATORS "UP TO DATE" CHURNS.**  
On 10 days' trial; dairymen investigate before you buy; product increased 20 per cent.

**CAT'S FREE GIBSON-STEWART MFG. CO. GIBSONIA, PA.**

**CONSULTING ENGINEERS** in mechanical, electrical, hydraulic, chemical and civil engineering. Avoid excessive fees by writing for advice to Stevens & Tyler, 825 W. 84th St., New York City.

**Binder Twine** FARMERS WANTED AS AGENTS AUGUST POST, Moulton, Iowa.

**AN ACRE OF CORN** and its possibilities under the Silage system—being the theme of **"A BOOK ON SILAGE"** By Prof. F. W. WOLL, of the University of Wisconsin. Newly bound into a volume of 195 pages and now being sent out by the SILVER MFG. CO., SALEM, O., is unquestionably the best book yet introduced on the subject. It includes:

- I—Silage Crops.
- II—Silos.
- III—Silage.
- IV—Feeding of Silage.
- V—Comparison of Silage and other Feeds.
- VI—The Silo in Modern Agriculture, and many valuable tables and compounded rations for feeding stock. They are going rapidly.

To avoid disinterested inquiries the Price is 10c. coin or stamps.

SILVER MFG. CO. Salem, Ohio.

**BELTING**

We carry a complete stock of all kinds of RUBBER and LEATHER BELTING. We buy our goods at Sheriffs' and Receivers' Sales. Write for FREE ILLUSTRATED CATALOGUE No. 34 on Hardware, Pipe, Roofing, Plumbing Material, Wire, Rope, Dry Goods, Clothing, etc., etc. **OUR PRICES ARE ONE-HALF OF OTHERS**

Chicago House Wrecking Co., W. 35th & Iron Sts. CHICAGO.

**VICTOR Low-Down WAGONS** HANDY

Strongest, most durable, all-metal wheels, wide tires. Axles, hoods, bolsters, etc., of thoroughly seasoned woods. Cost one-half less than high wagons. Positively guaranteed. Write for description and prices.

GEO. ETEL CO., Quincy, Ill.

The Hemet Lands Are Located in **SOUTHERN CALIFORNIA**

Soil and Climate suitable to the cultivation of the Orange, Lemon and Olive. All other products successfully grown. Abundance of water. Good market. Educational and religious advantages. Illustrated Pamphlet giving reliable and instructive facts and figures sent FREE. Address Hemet Land Co., Dept. A., Hemet, Riverside Co., California.

**SAVE THE MONEY**

you are spending on repairs and buy new wheels. It is cheaper and in every way better. We sell 4 Buggy Wheels, 7-8 in. Steel Tire for \$7.50 4 Carriage Wheels, 1 in. Steel Tire for \$8.00 Other wheels for other purposes equally low priced. Measuring directions free. Write for price-list No. 31.

WILMINGTON WHEEL CO., Wilmington, Del.



## CARE OF BEES

There is no need for any beekeeper, even of the most primitive order, to use such things for beehives as nail-kegs, or a soap-box for a super, to have his surplus honey stored in. Our forefathers may have been excusable for such a practice. But nowadays good beehives with the best approved surplus arrangements may be bought at a low cost of the apiarian supply dealer. It gives much more satisfaction to harvest fancy honey in the universally adopted one-pound sections than an inferior grade of honey in soap-boxes. The supers should never be used without separators or dividers, at least not by the inexperienced. The use of separators will prevent the bees from bulging the combs. No variation in the thickness of combs can occur.

The beekeeper will find it to his advantage to have on hand a sufficient number of hives, supers and sections to meet any possible emergency. Every colony in a box-hive may send out two or three swarms, and provisions should be made accordingly. However, it is not necessary to have all these swarms, small or large, separately. On the contrary, it will be much more profitable to unite several at the time of hiving, even should there be several days between the several swarms issuing; but first swarms and after-swarms never should be united. The first come forth with the old fertile queen, while the others are headed by a young, or virgin, queen. This is probably the reason why prime and after swarms do not unite peaceably. If my stock of bees was constituted largely of box-hives I should want them to swarm as much as possible. The young swarms I would hive in pairs, or in case of after-swarms in threes or fours, or enough of them to make not less than ten or twelve pounds of bees, and I would give plenty of section-room. Thus I would be enabled to produce just as fine an article of comb-honey as any professional in the land.

It is not necessary to buy the hives needed ready made. It is cheaper to buy them in the flat; this also saves freight. The hives and surplus receptacles should be made up before the honey season opens, and the sections provided with guides—small pieces of comb-foundation. Every beekeeper, non-professional as well as professional, should read some bee literature and find out what others are doing. Much may be learned by reading and by mingling with those who are engaged in the same business we are in.

## A BEE DISEASE

The most serious malady bees are subject to is foul-brood. As its name implies, it is a disease of the brood or larvae, and the cause of it is a kind of fungus, the bacillus alvei. It is of vegetable growth—a little plant, perhaps—and we may well compare it with the well-known mildew. Both prey on the tissues of other bodies, the latter on dead matter, the former principally on living beings, as in the case of bee larvae. The bacillus alvei is so very small that it can be seen only with the help of a powerful microscope. Millions of these little plants may be contained in the body of one bee larva three eighths of an inch long. When greatly magnified it does not look unlike a bit of broken-off timothy straw with a few hairs at each end, which the little robber uses somewhat as a fish uses fins and tail. Mr. Harry Howe, of Ithaca, explained the nature of the bacillus alvei before the New York State Beekeepers' Society. He had given much time to the study of this subject, and he said, "The bacillus multiplied by division. When it had developed sufficiently it would simply break in two, each half continuing in growth as a separate organism and with such rapidity that in two or three hours each bacillus was again ready for division. So they continue to increase in geometrical proportions."

The bacillus alvei also increases by spores. In plain words, the bacillus is the plant, the spores are the seeds by which the disease is transmitted from one organism to another. These spores are so very small that they almost escape the vigilant eye of the microscope. They are very light, float in the air, and are thus easily carried by the wind.

Carbolic acid, salicylic acid and phenol are substances which, when brought in contact with the bacilli, will kill them at once; but the cure with these chemicals is laborious and dangerous, and it is now considered the safest and best to burn all the combs of badly affected colonies with all the brood and honey they may contain, then subject the bees to a starvation cure, after which they may be allowed to build up in a renovated or new hive. To facilitate this work the frames of the hives may be filled with comb-foundation and the colonies fed for a while with medicated syrup. F. GREINER.

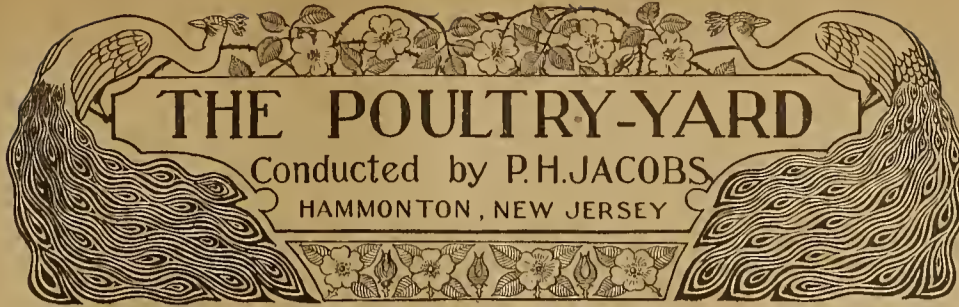

## POULTRY AS A FARM ADJUNCT

IF POULTRY should be made a specialty on the farm, and the flocks be increased to a number that would permit the farmer to devote his attention thereto, the profit received in proportion to the labor bestowed would be larger than that derived from cattle. In fact, considering that the fowls on the farms really receive little or no care is alone sufficient evidence that with excellent management and the use of selected breeds the farmer would be more favorable to poultry if he would make the experiment. So long have the farmers overlooked poultry that it is surprising how many inquiries come from that class asking information on the methods of management, yet these farmers are well familiar with the care and management required for horses, cattle, sheep and swine. It is, however, credible to such farmers that they are disposed to learn more, and they will make no mistake in placing the poultry department of the farm upon a plane higher than that now occupied. The course to pursue is to gradually increase the flocks every year, and not venture too largely at first, so as to gain experience while learning the business, and in a few years there will be a good profit coming in from poultry, the capital invested therein having been created by the fowls during the progress of development of the business. Leave the female members of the family out, for they will not be able to attend to large flocks, and begin in the poultry business with a determination to succeed in a few years, securing as much profit as possible with the least outlay for buildings and labor.

## LICE AND REMEDIES

Chicks hatched later than May will sometimes make slow growth, hence are driven from their nests by the millions of red lice, and the large head-lice torment the fowls until exhaustion ensues. At night the hens cannot rest, and disease appears because the vigor of the flock has been lowered to a point where the birds cannot resist contagion. One of the essentials now is to provide a dust-bath, or keep a space always spaded and loose, so that the birds can dust. Whenever you notice a fowl rolling on the ground, as though endeavoring to dust itself, it is a sure sign that lice are at work. When the hens do not lay, examine their heads for the large lice, and also clean out and drench the poultry-house. Boiling water or hot soap-suds will kill lice instantly, but the remedy must be used freely; that is, drench the house, every portion, with kerosene emulsion or boiling water, and repeat it twice a week until no signs of lice can be noticed. The hens will then rid themselves of lice with the dust-bath. The advertised lice remedies are cheap and excellent.

## BLOOD AND BONES

The principal food ingredient in the blood is nitrogen, which is also the most essential substance in albumen, or the white of egg. Dried blood contains about fourteen per cent of nitrogen, while green bone may contain but one or two per cent, as the bone is mostly phosphate of lime. Bone varies. If it has adhering meat it will contain more nitrogen than if clean. Blood cannot entirely take the place of bone, as the bone contains phosphates. The dried blood will answer as a substitute for fresh blood, but no kind of dry food, whether animal or vegetable, is equal to that which is fresh.

## WATER NECESSARY FOR DUCKLINGS

A young duck will sometimes choke if it has no water to drink when eating. The water must be deep enough to allow the duckling to get its head and bill down in the vessel, as with each mouthful it cleans its bill. This is the reason ducklings appear to throw water all over the floor. They are simply cleaning their bills, which prevents clogging of the nostrils and permits them to breathe. They should have no water to swim in, but water is a necessity with them when feeding, as they wash down the greater part of the food eaten, some of them apparently not swallowing the food at all.

## "PIP"

What is known as "pip" is simply a "cold in the head," but it is the beginning of roup. If taken in time it is not difficult to cure. The birds are to all appearances well, eat with good appetite, and lay, the only indications of difficulty being the occasional sound of "pip" which the bird utters. Put into a sewing-machine can two tablespoonfuls of camphorated oil, the same of crude petroleum, and twenty drops of carbolic acid. Shake well, and inject two drops of the mixture into each nostril. The remedy arrests the disease and prevents it from changing to a more serious difficulty. If the bird is sick inject two drops of the mixture into each nostril with the sewing-machine can, and then push the spout of the can down the throat and discharge four drops from it. Do not use much at a time, but the operation may be repeated every five or six hours if necessary. With a large flock of sick birds this cannot be done without handling them, and as a substitute burn sulphur, turpentine and gas-tar in the poultry-house after the birds go on the roost.

## STRAW-COLOR

White fowls sometimes lose their clear white color as they get well into summer or near the close of the year. It is known as "straw-color," and no white breed is entirely exempt. It is not due to the food, but is caused by the direct rays of the sun. Where fowls are kept in the shade the straw-color is not so deep in hue. It may also partially disappear (by bleaching) where the birds are kept out of the action of the sun. Old hens show the straw-color more than pullets. When the fowls molt the new feathers are white, and the birds again have that beautiful clear white appearance so desirable, but the straw-color begins again and gradually deepens until the next molt. There is no remedy but to keep the birds in the shade, which is not feasible at all times.

## EGG-EATING

Egg-eating is a vice. One hen learns it and teaches the others. She finds a broken egg, discovers that it is good eating, and thereafter she seeks such. Fat hens, lazy hens, idle hens and hens that get no animal food, exercise or a variety are subject to it. It is not in the breed, but in the individual. Use no nest-egg unless of wood or porcelain. Have the nest off the ground, so that the hen cannot reach the egg, and make the nest so that there is barely room for the hen, so that she cannot stand perfectly erect or eat the egg. She will come off to eat it, but cannot then reach it. Collect the eggs frequently. Leave a few plaster-of-Paris eggs on the floor to work on. They will soon believe that all eggs are alike.

## INQUIRIES ANSWERED

**To Make Them Lay.**—L., Robart, Ky., writes: "What can I give hens to make them lay?"

**REPLY:**—Much depends on the condition of the fowls. They may have lice, may have been overfed, or may have disease. Details of management should be given.

**Packing Eggs.**—C. D. S. writes: "How can eggs be packed in summer to keep into winter?"

**REPLY:**—It cannot be done and have them sufficiently fresh to get good prices. Eggs may be kept three months if the males are removed from the hens and the eggs kept on racks in a cool place and turned twice a week. One cannot buy eggs and make a profit by storing them, unless with cold storage.

**Pigeons.**—B. S. G., Bart, Pa., writes: "Does it pay to raise pigeons inclosed? How should they be fed?"

**REPLY:**—It is probably the only proper way to keep them, and they are profitable. Give wheat, cracked corn, oyster-shells, grit, and have a hox of animal-meal convenient. A salt codfish should be placed within reach. Chopped green food, seeds of all kinds, and a variety will be relished.

**Feeding.**—W. C. J., Waukesha, Wis., writes: "Does burnt bone answer as grit for fowls? What should be the weight of a morning meal composed of equal parts of oats, barley and wheat for eighty fowls. Is ground oats (hot mash) good for the night meal?"

**REPLY:**—Burnt bone does not supply the place of sharp grit. The food for eighty fowls depends upon many conditions, such as range, etc.; about twenty pounds should be sufficient for a morning meal. The warm oats are excellent, but are unnecessary in the warm season.

**IT BEATS THE BUGS**

No matter if you have a dozen other sprayers, you will find use for this one. Every farmer, gardener, fruit or flower grower and poultry-keeper should get our

**Vapor Gem Sprayer**

Not so large as some, but the handiest of all. Tank and pump of heavy copper. Will last 20 years. One loading sufficient for an acre of vines. Regular price, \$2. Order immediately and get reduced price, \$1.50, express prepaid. Also agency. Send P. O. order for one now. **WRITE TODAY.**

**FIELD FORCE PUMP CO.,**  
26 Market St., LOCKPORT, N. Y.

**For Any Soil**

For soft or rocky ground, the harrow that does the best work and draws easiest is

**Hench and Dromgold's** riding or walking

**Spring Tooth Wheel Harrow**

Send for free catalogue of best harrows, cultivators, corn planters, grain drills, etc.

**HENCH & DROMGOLD, York, Pa.**

**THE EMPIRE Cream Separator**

**IS THE BEST.**

We place machines on 10 days' trial to prove this. Write for particulars and catalogue.

**U. S. Butter Extractor Co.,**  
Orange St., Newark, N. J.

**BICYCLES FOR EVERYBODY. NO MONEY IN ADVANCE.**

Shipped direct to anyone and guaranteed as represented or money refunded. Save agents large profits and get a wheel at rock bottom wholesale price. Our Arlington Model K is the greatest bargain ever offered; in lots of one or more at \$14.85

**\$14.85**

\$35 "Arlington" \$16.50  
\$40 " " \$18.50  
\$50 "Oakwood" \$21.50

Good wheels \$12.50, \$11.00 & \$10.00 Stripped Wheels \$7.00 the Arlington & Oakwood are strictly high grade and the best that can be made. Thoroughly tested and fully guaranteed. Over 100,000 riders can testify to their superior quality, style, construction and workmanship. Illustrated catalogue free. **CASH BUYERS' UNION,** 162 W. Van Buren St., B-7, Chicago, Ills.

**FIRE, WEATHER, and Lightning Proof**

Black, painted, or galvanized metal **ROOFING** and siding; (brick, rock or corrugated)

**Metal Ceilings and Side Walls**

in elegant designs. Write for Catalogue.

**The Penn Metal Ceiling and Roofing Co., Ltd.,**  
23d & Hamilton Sts., Phila., Pa., or 24 Hancock St., Boston, Mass.

**GEM FULL CIRCLE Baler**

Warranted the highest, strongest, cheapest & fastest Full Circle Baler in the market. Made of wrought steel. Can be operated with one or two horses. Will bale 10 to 15 tons of hay a day. Write for description and prices.

**GEORGE ERTEL CO., QUINCY, ILL.**

**HOW MANY APPLES**

does it take to make a barrel of cider? No matter; it will take less if you use

**HYDRAULIC CIDER PRESS**

and the cider will be better, purer and will keep longer. Don't buy until you get our catalogue.

**HYDRAULIC PRESS MFG. CO.**  
6 Main Street, Mt. Glend, Ohio

**THE BEST BUTTER**

and the most of it is made by using our improved patent

**AQUATIC CREAM SEPARATOR.**

It takes all the cream out of milk, expels all foul odors and impurities in two hour's time. Better than any creamery made and costs less than half as much. For 1 cow up to 40. Can't get out of order. No experience necessary. Prices, \$5 to \$11. Free catalogue and testimonials. Reliable Agents Wanted.

**Aquatic Cream Sep' for Co., 125 Factory Sq., Watertown, N. Y.**

**4 Buggy Wheels with Tire on, \$6.75**

**With Axles and Boxes Set, \$9.75**

I make all sizes and grades. Carriage and Wagon Hardware of every description. Send for catalogue giving prices on wheels \$ to 4 in. tread, with full and plain instructions how to order. Address **W. F. BOOB, Center Hall, Pa.**

**DON'T SET HENS THE SAME OLD WAY**

The Nat'l Hen Incubator beats old plan \$ to 1. Little in price, but big money-maker. Agts. wanted. Send for cat. telling how to get one free.

**Natural Hen Incubator Co., B 22, Columbus, Neb.**

A. Edwards writes, "Would not take \$100 for N. H. I. Plan."

**MONEY IN BEES**

and how to get it is told in **GLEANINGS IN BEE** magazine, employing the best experts on the subject. Sample and valuable book on Bees and Bee Keepers' Supplies free to all who mention this paper. **The A. I. Root Co., Medina, O.**

**DEATH to LICE** on hens & chickens. 64-p. Book Free. **D. J. Lambert, Box 303, Apponaug, R.I.**



## QUERIES

READ THIS NOTICE

Questions from regular subscribers of FARM AND FIRESIDE relating to matters of general interest will be answered in these columns free of charge. Querists desiring immediate replies, or asking information upon matters of personal interest only, should inclose stamps for return postage. The full name and post-office address of the inquirer should accompany each query, in order that we may answer by mail if necessary. Queries must be received at least two weeks before the date of the issue in which the answer is expected. Queries should not be written on paper containing matters of business, and should be written on one side of the paper only.

**Mushroom Culture.**—M. G. V., San Bernardino, Cal. Send to Secretary of Agriculture, Washington, D. C., for Farmers' Bulletin on Mushroom Culture.

**Keeping Squashes.**—E. H., Davison, Mich., writes: "I kept squashes until late in the winter by wetting them with Bordeaux mixture. May it not be possible to preserve vegetables and fruits by protecting them from the ferments and bacteria of decay by this process? Try it and report."

**To Disinfect Cistern-water.**—C. F. C., Norwood, Ohio, asks how to destroy a bad odor in cistern-water. The cistern is clean, and the water filtered through charcoal.

**REPLY:**—Dissolve a pound or two of caustic soda or concentrated lye in warm water. Pour this solution into the cistern and stir the water thoroughly.

**Mixing Ashes With Poultry Droppings.**—W. C., Milford, Delaware, writes: "Will mixing wood and coal ashes with hen manure destroy the fertilizing properties of each?"

**REPLY:**—If hard-wood ashes are mixed with hen manure the ammonia in the latter will be driven off and lost. Coal ashes, however, do not act on hen manure like hard-wood ashes or lime, and may be used as an absorbent. Gypsum, or land-plaster, mixed with hen manure will fix and save the ammonia.

**Fertilizers.**—T. B. E., Farmer, N. Y., asks if the continued use of commercial fertilizers will finally impoverish the soil.

**REPLY:**—True fertilizers are plant-foods. The three most important elements of fertility are nitrogen, potash and phosphoric acid. Heavy cropping cannot impoverish the soil if the fertilizer used restores all three elements to the soil. If, however, the fertilizer used contains only two of them, the supply of the other in the soil will be finally exhausted, and the crops will fail.

**Germination of Celery-seed—Leg-weakness in Chickens.**—J. T. C., Spring Valley, Ill., writes: "Will some of your readers tell me how long it takes for celery-seed to germinate? I have had some sowed in a box since February 2d and it is not up yet.—What can I do for a chicken that has leg-weakness?"

**REPLY:**—Celery-seed is small, and should not be covered very deep. Strict attention to watering is necessary. Usually it takes from two to three weeks for the plants to make their appearance.—Sometimes a fowl having leg-weakness will recover without treatment. If it does not, cure it for good by killing it.

**Balanced Rations.**—C. H., Dundee, Oregon, writes: "If I trade my wheat for middlings, pound for pound, to fatten young hogs on, how much do I lose or gain over feeding chopped wheat tolled by the miller?"

**REPLY:**—Make the trade by all means. You will save the toll and gain the difference between feeding a balanced ration and one that is not. The nutritive ratio required by growing fat pigs of one hundred pounds' weight is 1:5; the nutritive ratio of middlings is 1:4.7; the nutritive ratio of wheat is 1:7.2. The addition of corn to the middlings, increasing the amount as the pigs increase in age and weight, will make a ration perfectly balanced.

**Carriage-varnish—Harness-oil.**—E. N., College View, Neb., writes: "Tell me what to put into huggy-paint to make the buggy look like a new one.—How shall I proceed to oil my harness?"

**REPLY:**—After the buggy has been carefully cleaned, painted, and rubbed down smooth with pumice-stone and water, apply a flowing coat of black japau in the same manner as varnish. When this is dry rub off the gloss with pumice-stone as before, and then apply a coat of coach-varnish, made of gum copal, linseed-oil and turpentine.—For harness-oil melt three pounds of beef tallow, then add a little lamp-black for color, and one pound of neat's-foot oil, and stir till cool.

**Cement Walks.**—N. A. H., North Lima, Ohio. Excavate the earth, if clay or loam, between the side lines of the walk to the depth of eight inches. In this trench place a six-inch layer of clean gravel, not too coarse. Rake and tamp the gravel until it is packed uniformly and graded evenly. On this foundation spread a two-inch layer of concrete made as follows: To four parts of clean, sharp, fine gravel add one part of Portland cement; mix dry in a shallow box, then add water enough to dampen it, and work it over thoroughly. Tamp the concrete well, and smooth the surface carefully. For finishing, spread smooth with a trowel a half-inch coat of thin mortar made of one part of cement and two parts of clean, fine, sharp sand thoroughly mixed. Mix up just enough concrete at one time to make a section four or five feet long. The concrete, of course, is built between thick boards placed on edge at each side of the walk, staked firmly, and adjusted so that the upper edge will conform to the grade and surface of the finished walk.

## VETERINARY

CONDUCTED BY DR. H. J. DETMERS

To regular subscribers of the FARM AND FIRESIDE answers will be given through these columns free of charge. Where an immediate reply by mail is desired the applicant should inclose a fee of one dollar, otherwise no attention will be paid to such a request. Inquiries should always contain the writer's full address. Queries must be received at least two weeks before the date of the issue in which the answer is expected. Veterinary queries should be sent directly to DR. H. J. DETMERS, 1315 Neil Avenue, Columbus, Ohio.

**NOTE.**—Parties who desire an answer to their inquiries in this column must give their name and address, not necessarily for publication, but for other good reasons. Anonymous inquiries are not answered.

**Swine-plague.**—L. E., Lebanon Junction, Ky. What you describe appears to be swine-plague, or so-called hog-cholera. I cannot give you any remedy.

**Lame Horse.**—W. E. S. F., Sussex, N. B., Canada. I cannot give you any further advice. I am of the opinion that your horse may yet improve some, but will never get well.

**Diseased Ovaries.**—D. C. G., Celina, Ohio. Diseased ovaries can be removed, an operation comparatively easy in a cow, but rather dangerous in a mare. Any other treatment is out of the question.

**Cow Rubs Herself—Pig Cannot Walk.**—J. R. G., Brownsville, Tenn. Examine your cow, and without doubt you will find that she is lousy.—I cannot advise you concerning your pig that is unable to walk, simply because I have not the least idea what may be the cause of the inability.

**Diabetes.**—W. G. M., Springfield, Mo. If what you inquire about is a case of diabetes insipidus, as must be supposed it is, because there is not a word in your statement that would justify any other diagnosis, you must have fed spoiled or musty oats. Stop that, feed nothing but what is perfectly sound, and the trouble will soon disappear.

**Death of Cow and Calf.**—P. W., Mount Morris, N. Y. Although you do not say so, I suppose you desire to know what caused the death of the cow and of the calf. This might have been easily ascertained if a careful post-mortem examination had been made. As this has not been done, all I can say is that the food—moldy corn-stalks and chopped cabbages—may possibly constitute the primary cause.

**Possibly Actinomycosis.**—C. A. W., Arcola, Va. Although you give a very fair description of your case you neglected to state a very important point; namely, whether the enlargement is immovable and in the jaw-bone, or movable and only in the connective tissue. If the former is the case, any treatment, according to my experience, will meet with very poor success, especially if the morbid process has made as much progress as it appears to have in your case, while if the enlargement is confined to the connective tissues and movable, a cure can be effected with almost absolute certainty.

**Knots(?) on Horse's Shoulders.**—H. P. T., Odin, Mo. If you mean collar-boils and tumors, they are not caused so much by hard pulling as by ill-fitting collars and by collars that are not kept clean. How to remove such boils and tumors depends upon their condition, size and location. If solid and situated immediately beneath the skin they can usually be removed by making with a sharp knife an incision extending to the center of the tumor, and then by inserting into the incision a crystal of sulphate of copper, and leaving it right in the center of the tumor. After this has been done nothing is needed but keeping the wound clean until a healing has been effected. The scar left behind will be comparatively small. That the animal must be exempted from work until a perfect healing has taken place is self-evident. If such a tumor is deep-seated it can be removed only by a surgical operation, to be performed by a surgeon.

**Probably the Botallian Duct Not Closed.**—F. J. L., Gold, Pa. During the fetal life a short blood-vessel, known as the Botallian duct, connects the pulmonary artery with the posterior aorta. If everything is normal, this duct, which has functions to perform during the interuterine existence of the young animal, closes as soon as the young animal is born and draws its first breath. If it is not closed, as it happens in rare cases, only a portion of the blood that has circulated through the body will reach the lungs and be decarbonized, hence the process of nutrition will be very defective, and the skin of white-colored animals will present a bluish-red color, and the respiration will be laborious, or hard work, as you express it. This, according to your description, appears to be what ails your pig. That nothing can be accomplished in such a case by medication will not be necessary to tell you.

**Prolapsus of the Vagina.**—R. F., Alexandria, S. D. Prolapsus of the vagina is quite a frequent occurrence in cows a month or two before calving if they lack exercise, receive too much bulky food and are compelled to stand with their hind feet considerably lower than the fore feet. More exercise, more concentrated and less bulky food and a level floor will prevent it unless the cow has been thus affected year after year, and the tissues in question have become extensively relaxed. In such a case the floor of the stall must be raised behind to such an extent that the cow will be compelled to stand higher with her hind feet than with her fore feet; or, what is the same, if she lies down she must be compelled to lie down in such a way that the weight of the intestines will—slightly, at least—press forward. The prolapsus as a rule occurs when the animal is lying down. Such a prolapsus rarely causes any danger, but needs attention when the cow is calving.

**Cows Their Own Milkmaids.**—W. A. S., Argonia, Kan. If your cow attends to her own milking—sucks herself—you can easily spoil her fun by making her a halter with a strong leather nose-band with two rows of sharp-pointed nails in it, the lower row slightly pointed downward and the upper row slightly pointed upward. With such a halter on she will soon find a "hair" in the business of acting as her own milkmaid, and will stop it.

**Vitiated Appetite.**—W. C. B., Windsor, Ill. The vitiated appetite that causes sows to eat their pigs is usually due to grave dietetic mistakes; in other words, to being kept on food that lacks some necessary constituents needed and craved for by the animal organism. Give a variety of food to your hogs, but particularly to the brood-sows, and thus provide all the elements of which the animal organism is composed—nitrogenous compounds, phosphates and lime salts included. Further see to it that they are not costive at the time of pigging. Still, even if this is done, a sow that once has devoured her pigs is apt to do it again unless she is closely watched during the first few days after pigging. It is possible that a hypodermic injection of apomorphin hydrochloride, say two grains in just enough distilled water to dissolve it, although it will cause vomiting, will for the time being cure the vitiated appetite if injected as soon as the pigs have been born.

**Broken Leg.**—J. W., March, Wis. Whether a broken leg of a cow can be satisfactorily brought to healing without leaving the cow a cripple depends upon (1) the condition of the fracture itself—whether it is simple, splintered or compound; (2) which bone has been broken; (3) the age and condition of the animal. A really favorable prognosis can be made only if the fracture is simple, neither splintered nor compound, if it is in the middle or not far from the middle of a bone to which a suitable bandage can be applied, and if the animal is young, or at least not too old, is in a good condition, and can be well cared for. Simple fractures in bones surrounded by muscles will also admit a union, but as a rule will afterward be much shorter, and therefore leave the animal a cripple. If a bone is splintered, or the fracture a compound one, or if the same has occurred at a place in which the broken ends are pulled apart by the muscles clear out of contact with each other, the prognosis is bad.

**Agalactia in a Mare.**—E. M. B., Hill Top, Col. Agalactia, or want of milk, is not an infrequent occurrence in young mares having their first colt. If there is some milk, good food, particularly oats, some soft food, and every day a small dose of salt if the mare is kept in the stable, and good green grass and clover if the mare can go to pasture, will effect an increase; but as a rule such a mare will never make a good nursing mother. Quite a number of so-called milk-producing remedies and milk prescriptions have been recommended, and I will give one of them for what it is worth, but at the same time confess that I am not any too confident concerning its effectiveness. It is as follows: R. Stibii sulfurati nigri, three ounces; Sulfur sublim, one and one half ounces; Pulv. Fruct. Foeniculi, Pulv. Fruct. Carvi, Pulv. Fruct. Juniperi crudi, four and one half ounces; Sodii chlorati crudi, fifteen ounces. Give three times a day one tablespoonful with the food. As will be seen, the common salt, Sodium chlor. crudum, is the main thing.

**So-called Stagers.**—J. F. H., Palmetto, Fla. What you describe appears to be an acute or subacute leptomeningitis, and not what is usually denominated staggers, or blind-staggers, for this term, by common consent, is applied only to a chronic morbid pressure upon the brain-tissue, manifesting itself as what might be called amnesia, at times in more or less violent paroxysms, and at times as stupor and great dullness. Acute and subacute leptomeningitis may be produced by various and entirely different causes, and therefore cannot be considered as a well-defined disease. Among the possible causes I will mention (1) high temperatures if the animals are confined in close and illy ventilated stables or exposed to the direct rays of the sun, so-called sunstroke (possibly the cause in your cases); (2) sudden changes in the external surroundings and conditions, transportations by rail and from an elevated or mountainous country into lowlands, overexertions, unaccustomed heavy food, and close and illy ventilated stables, etc.; (3) overexertion after continued rest or extra heavy food; (4) too much heavy feeding, especially with leguminous plants and seeds, and with large quantities of rye; (5) external injuries causing lesions of the skull or concussion of the brain; (6) the presence of parasites, embolies, thrombi and new formations (tumors, etc.) in the brain; among the parasites the larvae of *Strongylus armatus* or *Sclerostomum equinum* and *Cysticercus coenurus* have been found in the brain; embolism has been observed in cases of horse-distemper and pharyngitis; (7) the symptoms of leptomeningitis may also be produced in certain infectious diseases as a secondary ailment; for instance, in cases of septicemia, pyemia, infectious pleuropneumonia of horses, pox, etc. As said above, it appears to me to be most likely that the seventy-five cases you mention have been caused by excessive heat either in close and illy ventilated stables or by direct exposure to the rays of the sun. If such is the case the treatment, to be applied as soon as possible, would have to consist in taking the animals at once to a cool and shady place with a pure atmosphere, and in fastening to the top of the head of the affected animal a small bag with crushed ice, or where that cannot be had, in fastening to the top of the head some folded gunny-sacks kept constantly saturated with cold water. If internal medicines can be brought to action, which, on account of the existing disturbance of the functions of the nervous system, is but seldom the case, a physic may be administered and some salt-peter may be given in the water for drinking.

**KEYSTONE SIDE DELIVERY HAY RAKE**

Unparalleled success in handling all kinds of hay including alfalfa. Catches the hay at a side angle and rolling it over, tosses it into a light airy windrow. Saves the use of a tedder for the hay cures crisp and sweet in this windrow—is not sunburned or bleached.



It follows the mower closest—makes richest hay. Rakes wide, fast, clean.

Its revolving rakes never touch the ground to scrape up trash. It runs "smooth and easy." No dumping or work for the driver. It will save expense and waste, and bring you top notch quality and price. Get full description of this and the Keystone Hay Loader.

KEYSTONE MFG. CO., 21 River St., Sterling, Ill.

**The Big 4**

1 The Dixie and Columbia Grain Threshers, the greatest savers and cleaners on earth.

2 The Matchless Clover Huller, it saves 1/2 more seed than any other machine and cleans it to perfection....

3 The A. & T. Farm and Traction Engines, the easiest steamers and most durable in the world.

4 The A. & T. Saw-Mills, are up to date and saw true, marketable lumber.....

MANUFACTURED BY The Aultman & Taylor Machinery Co., MANSFIELD, OHIO.

Send for free Illustrated Catalogue and mention this paper



**It Would Look Better!**



More homelike, if your lawn were neatly fenced. This HARTMAN STEEL ROD LAWN FENCE with steel posts is most durable, handsome and cheap. Look into the matter. Illustrated catalogue free. HARTMAN M'FG. CO., BOX 26 ELLWOOD CITY, PA. Or Room 77, 809 Broadway, New York City.

**YOU WANT FENCE—WE WANT MONEY.**

We will exchange our fence for your money.

We Make an Honest Fence at a reasonable price.

WE SELL DIRECT TO FARMERS AT WHOLESALE PRICE. That saves you the dealer's profit which amounts to a nice thing on a bill of fencing. No loose ends—can't slip, untwist or unravel. All cross wires interwoven. Presents free 30 days' free trial. Warranted 20 years.

ADVANCE FENCE CO., 116 Old St., Peoria, Ill.

**Steel Wheels**

Staggered Oval Spokes.

BUY A SET TO FIT YOUR NEW OR OLD WAGON CHEAPEST AND BEST

way to get a low wagon. Any size wheel, any width tire. Catal. FREE.

Electric Wheel Co., Box 96 Quincy, Ills



**EVERGREENS.**

Largest stock in America, including Colorado Blue Spruce and Douglas Spruce of Colorado.

Also Ornamental, Shade and Forest Trees, Tree Seeds, Etc.

R. DOUGLAS & SONS, WAUKEGAN, ILL.



**BUCKEYE FORCE PUMPS**

Are Leaders in the Trade because they work easy, throw a steady stream, do not drip, do not freeze, but

**PLEASE ALL WHO USE THEM**

They are made to pump and to last, and they do both. The complete embodiment of pump goodness. Write for circulars.

MAST, FOOS & CO., 24 River St., Springfield, Ohio



**\$14** If You Want to SAVE MONEY and get the best machine at lowest wholesale price, now is your chance. Buy direct from factory, one profit. All attachments free. 30 days' free trial. WARRANTED 20 YEARS.

\$40.00 Arlington for.....\$14.00  
\$50.00 Arlington for.....\$17.00  
\$65.00 Kenwood for.....\$21.50

Other Machines at \$9, \$10.50 & \$12

Illustrated catalog and testimonials free. CASH BUYERS' UNION, 158-164 W. Van Buren St., B-7, Chicago, Ill.



**PAGE**

**YOU'D SLEEP BETTER**

if you used Page Fence for your brachy stock.

PAGE WOVEN WIRE FENCE CO., ADRIAN, MICH.





THE GRANGE

Conducted by MRS. MARY E. LEE, New Plymouth, Ohio

EDITORIALS

THE national lecturer presents a symposium on co-operative business enterprise this quarter that is of much interest to all farmers. The May topic, "Co-operation in the Sale of Farm Products," is especially timely. Farmers have learned by experience the economy of co-operation in buying. They have learned to dispense with a long line of middlemen. The next step is to co-operate in selling farm products, eliminating the factor of middleman from the equation, and pocketing the profits that usually accrue to that class. All have marked the difference between the selling price of the producer and the cost price to the consumer; often it is double the selling price, and this on articles that do not need the intervention of the manufacturer. With such products as grass, clover and cereal seeds, potatoes, fruit, etc., that farmers of one section sell to farmers of another the exchange might be easily effected without the intervention of the costly middleman. We hope that out of the discussion of this topic will grow a determination to thus co-operate in the selling of farm produce. There are many other matters to consider in this connection, such as co-operation in selling produce on the general markets, the study of business methods, the necessity of honesty and uniformity in selling products. Send us the pith of the discussions in your grange.

\*\*\*

Two hundred and twenty-five congressmen petitioned that an increase of \$40,000 be appropriated for the purchase of seeds. This makes the appropriation nearly \$110,000. One hundred and ten thousand dollars appropriated for the purchase of seeds that nobody wants, that will not grow, or if by some unlucky chance they do sprout, send up myriads of weeds and vegetables too rank and coarse for human palates to endure. Evidently the astute congressmen believe they will grow votes. One county editor wrote his congressman last year that if he sent him any more seeds he would use all his influence to defeat him for nomination. The deluded editor, with a show of agricultural lore, scattered the seeds broadcast, at the same time doing a little work for his candidate. But when the seeds grew luxuriantly into weeds of the most obnoxious kind the deluded constituency swept down on the poor editor, stopped their subscriptions, and consigned him to limbo. This might be a means to stop the free-seed farce.

\*\*\*

BELT, MONT.—To organize a grange you must secure at least thirteen charter members, four of whom must be women. The initiation fees for men are one dollar, women fifty cents. As Montana has no state organization it will be necessary to write to the national master, Aaron Jones, South Bend, Indiana, asking him to send an organizer to help work up a strong grange and give you the necessary instructions. The expenses of the organizer will not fall upon you. We hope you may be successful in organizing a grange in your community, and that from it will radiate grange light and enthusiasm. If you had sent your full name and address we would ere this have put you in possession of literature, and in correspondence with the proper authorities.

2

PURE-FOOD LEGISLATION

The "Breeder's Gazette," under the above caption, says: "Senator Mason has introduced into Congress a general pure-food law that should meet with favor. Of course, it is strenuously opposed by the parties in interest, who do not wish to be forced to inform the public of the methods by which they make their money in the substitution of inferior ingredients. Senator Mason's investigating committee uncovered enough of these frauds to show that there is much rottenness throughout the world of manufactured food products, and it is high time that the remedy was applied. Senator Paddock, of Nebraska, was the first to bring this great problem before the eyes of the people, and the work that he did in this line, while failing of crystallization into law, yet paved the way for the enactment of remedial legislation that is sure to be provided. With concerted action this legislation is well within our grasp now. Despite the bitter opposition of manufacturers, a law that will enforce common honesty in the manufacture

and sale of foods can be obtained from the present Congress if the consumers of the country will say the word. The National Pure Food and Drug Congress and the Department of Agriculture are behind the efforts now being made to secure this legislation, and the people who suffer from these adulterations are called on to make their influence felt at Washington. The producers of pure products are vitally interested in this matter, as well as the general consumers, and we trust the 'Gazette' readers will take the time to write their congressmen in advocacy of the pending measures."

On this point we have a very pertinent word from Mr. Samuel B. Woods, president of the Virginia State Horticultural Society. We quote:

"Resolutions do not count for much, and are not needed, but individual letters from the farmers, stock-raisers and fruit-growers. It does not matter whether the farmer knows the congressman personally; the congressman knows that the latter has a vote. In the state of Missouri, for instance, resolutions favoring the pure-food bill have been passed by the State Board of Agriculture, the Horticultural Society, the Horse-dealers' Association, the Road Association, the Swine-breeders' Association, the Poultry Association, the Sheep-breeders' Association, the Improved Live-stock Association and the State Grange. The farmers in many other states have been as active. This is well. But resolutions get pigeonholed and are forgotten. Fifty letters to each senator and congressman would be of more practical value than all the resolutions the United States could pass, and would insure the passage of the measure."

Those familiar with affairs at Washington understand that Mr. Woods is eminently correct in his estimate of the influence of personal appeals to congressmen. The representatives of the people are not beyond their reach at Washington. They have their ears well on the ground listening for the rumble that conveys an inkling of popular opinion, and a few plain and pointed letters to members of the House and Senate will work wonders. The righteousness of the pending legislation is beyond dispute. Will a hapless public longer continue to swallow adulterations and mixtures and compounds, some of them actually deleterious to health, in order that dishonest manufacturers may fatten at the expense of their pocketbooks and health?

THE SUCCESS OF THE GRANGE

An undertaking is said to be successful when it accomplishes the purpose designed. A teacher enters a school for the purpose of imparting knowledge to youth, and the school is counted a success if the noble purpose of the teacher is accomplished. The preacher who can move the hearts of his hearers and draw them to listen to his teachings and into the fold of the church is called a successful pastor. The lawyer who clearly understands the principles of law, and puts forth his exertions in advocacy of justice and right, and can move juries to believe in his advocacy, and so assist in overcoming wrong and aiding in the establishment of right, is called a successful lawyer. The physician who devotes his life to the study of the science of health and the use of remedies whereby he can arrest the progress of disease and prove instrumental in restoring to health, and in the relief of physical suffering, has the reputation of being a successful physician. In all these cases the measure of success is regulated in proportion to the accomplishment of the most good from the various purposes aimed at. The same rule applies to the grange. In it there is an aggregation of an individual membership, and its purpose is to benefit not only its membership, but the community where it exists. This benefit extends in various lines; it seeks to encourage the most approved methods of farming, protect the farmer, so far as may be, by encouraging healthy and just legislation, and opposing that which is vicious or inimical to the best interests of the farmer. It seeks to elevate his intellectual, moral and social standing in the community, and that of his family, and through the advantages thereof aid his general prosperity; but the benefits to individuals will depend upon their power of receptivity. Individuals are unlike in physical and intellectual capacity, and these conditions become a measure of expected benefits. The stronger body can endure greater physical exertion, and so accomplish more work; so, too, intellectually the powerful mind can assimilate more mental food. If the grange in the intellectual line puts forth efforts for the improvement and strengthening of the minds of its members, and accomplishes that in a degree—no mat-

ter if so far as its individual membership is concerned it is upon a sliding scale—in that line it is a success. If it serves to advance the social powers of its members by removal of the barrier of bashfulness or diffidence, leading to a better and higher degree of self-confidence and self-reliance, in that line it is a success. If it leads to a higher estimate of moral responsibility, and encourages a desire to do right because it is right, and to discountenance wrong because it is wrong, in that line it is a success. If by its consideration and discussion of agricultural or farming topics, thereby disclosing different methods of practice and accompanying results, the best methods are decided upon and adopted, insuring in the aggregate better results, in that line it is a success. If through the energy and activity of its officers and members the meetings are made so interesting through its regular programs as to attract full attendance to all its various meetings, in that line it is a success. If through the exercise of its influence as an aggregation of farmers it prevents pernicious legislation, and aids and encourages wholesome and beneficial legislation, in that line it is a success. If because of its interesting meetings, the reputation of which spreads abroad, there becomes an inducement for joining the grange or for members of other granges to attend its regular meetings, then it is a success. Finally, if in conferring the degrees of the order there is approval coupled with high commendation by those high in official position, then again in that line it is a success. All of this depends upon active, willing, combined efforts of the members of the order. Applying the test, how many granges would be entitled to the qualifying word successful, and how many would be compelled to feel the force of the scriptural sentence, "Mene, mene, tekel, upharsin?"

Connecticut. WILLIAM H. YEOMANS.

[Mr. Yeomans has set a high standard of excellence for individuals and granges. We are glad he has brought before us an ideal to be attained. Let us always keep in mind the possibilities of our order, and labor to place it on the highest plane of human endeavor.—ED.]

DEBT THE FOUNDATION OF TROUBLE

Debt makes everything a temptation. It lowers a man in self-respect, and places him at the mercy of his tradesmen and servants. He cannot call himself his own master, and it is difficult for him to be truthful. He is subject to bias and influence, obedient, compliant, servile, not self-directing nor a man of independent mind. He is not exempt from control or reliance on others. When you go in debt you give to another power over your liberty; hence, the Order of Patrons of Husbandry in their declaration of purposes discourage all indebtedness, discountenance the credit system, the mortgage system, and everything wasteful, extravagant, for all tend to bankruptcy, ruin and misery. It also declares that, united by the strong and faithful tie of agriculture, we mutually resolve to labor for the good of our order, our country and mankind; to foster mutual understanding and co-operation; to sell together and buy together for our mutual protection and advancement; to reduce expenses by buying together and paying cash. We thus secure our supplies at wholesale, which saves us from going in debt, which enables us to be free men and women.

The Order of Patrons of Husbandry has done more the past twenty years in doing away with the credit system than all other means combined. The membership of the order in Ohio is falling into line more and more every year in the co-operative work of our trade arrangements. Realizing the advantage of combining orders and paying cash, we are enabled to go in the market as jobbers and attract the attention of manufacturers, so that they solicit our custom instead of us soliciting them. The combination of orders this year in several leading articles of farmers' supplies, such as binder-twine, fertilizers, fence-wire, and many others, certainly will attract attention. Our grange contracts for twine this year will cover over six hundred tons, and for fertilizer some thousand tons, which, by paying cash, we get prices less than jobbers can secure for us. All our farm machinery can be handled in the same way, with equally close prices, by combining our orders and paying cash. The grangers of each county combining their orders for any one article, as many counties are now doing, are on the right road.

Fraternally submitted,

R. L. HOLMAN,  
Co-operative Committee.

POTASH gives color, flavor and firmness to all fruits. No good fruit can be raised without Potash.

Fertilizers containing at least 8 to 10% of Potash will give best results on all fruits. Write for our pamphlets, which ought to be in every farmer's library. They are sent free.

GERMAN KALI WORKS, 93 Nassau St., New York.

TERRIFF'S PERFECT WASHER



SENT ON TRIAL at wholesale price. If not satisfactory money will be refunded. SOLD under a POSITIVE GUARANTEE to wash as clean as can be done on the washboard, even to the wrist- and neckbands of the most soiled shirt, and with far greater ease. Does not wear out the clothes. Economizes soap, labor and time. AGENTS WANTED. Exclusive territory given. Big money made. For terms and prices Address, Portland Mfg. Co., Box 27, Portland, Mich.

BICYCLES BELOW COST

5,000 HIGH GRADE guaranteed MACHINES with best equipment must be closed out. 1900 Models, best makes, \$11 to \$20 '99 & '98 Models, high grade \$5 to \$13 500 Second hand Wheels all makes and models, good as new, \$8 to \$10. Great Factory Clearing Sale at half factory cost. We ship anywhere on trial without a cent in advance. EARN A BICYCLE distributing Catalogues for us. Many earned a wheel last year. Our 1900 proposition is even more liberal. Write at once for our Bargain List and Special Offer. Address Dept. 43 B. MEAD CYCLE CO., Chicago

SAVES YOUR BACK. Carpet laying—hardest and most disagreeable work of house-cleaning time—is made the easiest by the Positive Carpet Stretcher and Tacker. Works perfectly, stretching the carpet to its place, feeding the tacks and driving them home to stay. Works on wheels; gets into all corners. Price only \$1.75. Circulars and special terms free. Deposit Pearl Button Co., Dept. F. Deposit, N. Y. Big Money for agents. Write today

FREE SILVER WATCH FREE! These Watches are Solid Silver, Ladies' or Gents' size, and at retail would cost upwards of \$8 or \$10, but to introduce our Persian Perfumery we will send you this Watch Free if you take advantage of our marvelous offer. If you want one CUT THIS OUT write to us without delay. With your letter send us your name & postoffice address and we will send you on contingent, to sell for 5 cents each, 20 cases of Persian Perfumery and our offer. After you receive the beautiful Watch we shall expect you to show it to your friends and call their attention to this advertisement. The Watch is sent Free, by Registered Post, on your complying with our advertisement, and the marvelous offer which we send, and it is Fully Warranted. You will be more than satisfied. Address at once, PERSIAN PERFUMERY CO., 19 Warren St., New York.

SENT FREE Solid GOLD OR SILVER plated Bracelet sent free to anyone for selling 5 sets of our Ladies Gold plated Dress Pins for 25c. a set (each pin set with an exquisite jewel). Simply send your name & address & we will send you the pins post-money & we will send you the fully engraved & the lock opens true & will take back all to-day. The MAXWELL CO.

50 Recipes THE LUSCIOUS STRAWBERRY 25 Cents a Dainty Little Volume containing more than Fifty Recipes for preparing and serving Strawberries, including full directions for canning, preserving, jelly-making, etc.

Brass Band Instruments, Drums, Uniforms, & Supplies. Write for catalog, 445 illustrations. FREE; it gives information for musicians and new bands. LYON & HEALY, 95 Adams St., CHICAGO.

\$5 BICYCLES CHEAPER THAN EVER from the OLD RELIABLE CO. Green Special Sale. Nearly 800 Bicycles, every one a BARGAIN. Must be sold. All makes, 2nd h'ds. \$5 and up. Late Models new \$11.50 and up. Shipped anywhere on approval. A few more good agents wanted. Big Money. Write to-day for big list and special offers never before approached. BROWN-LEWIS CO. Dept. (J) Chicago, U.S.A.

WANTED Reliable men or women to sell our goods to the consumer in communities from 1,000 to 10,000 population; permanent employment at good pay. Address THE GREAT EASTERN COFFEE & TEA CO., 301 South 10th Street, St. Louis, Mo.

BINDER TWINE We sell at less price than manufacturers would ask to-day in car lots. A postal will bring our price and samples. The Garver Bros. Co., Strasburg, Ohio.

SPECTACLES at wholesale. Send for catalog. Agents wanted. COULTER OPTICAL CO., Chicago, Ill.





## HOW THE SIXTH CELEBRATED MEMORIAL DAY

**F**LAGS, banners and other national emblems formed the principal decorations of the auditorium. "The fervent blue and brilliant red, White blended with starry spread," were in evidence everywhere. The regimental flags were also conspicuously displayed. A cannon was draped with black, and on it hung a memory wreath of white flowers. A large portrait of Abraham Lincoln surrounded by a star of illumined incandescent-lights occupied a most prominent position. An American eagle was draped in red, white and blue. Large stars in "our colors" appeared on the walls. An abundance of palms were effectively used. Only white flowers were chosen, in memory of the day. These included carnations, lilies, roses, hyacinths and lilacs.

The sight of the tattered old flags which our fathers fought under recalled thrilling memories of the bloody times in '61.

At each table there were several soldiers. These hosts included two generations of soldiers—the veterans, the heroes of '61, and the sturdy volunteers of Santiago and Manila in '98. Other soldiers served acceptably as waiters, and still others were "behind the scenes" as cooks, for this was entirely "a man's affair" in the management. The ladies were pleasantly welcomed as guests, and hospitably entertained.

"The world's people"—that is, epicures—could supplement the frugal repast, a very realistic one, from the canteen, a tent with a gray-haired and bullet-scarred veteran—the commissary-general—in charge. Several of our young soldiers, his "aides," sold a surprising amount of milk, cheese, sandwiches, butter, roasted potatoes, cookies, popcorn, fruit and lemonade. They sold tempting-looking pies, too, as a man was the caterer. The result proved his excellent judgment.

For souvenirs menu-cards printed in red, white and blue, and having on the covers a small but good portrait of Lincoln and one of McKinley, were "given away" at the canteen. Only the camp-fires were missing. Our ingenious civilization could not provide these.

Around the frugal board army stories were vividly told, old memories revived, the valorous deeds of their fallen comrades tenderly related, hardships relived, victories won anew under "Our banner which floats forever!"

ADELE K. JOHNSON.

### A CHAPTER ON DOILIES

But few directions will be necessary in describing the doilies illustrated. All are made of fine linen lawn with No. 100 cotton thread. Flax may be used if desired. With the exception of No. 3 the tatted lace is made of No. 60 thread.

No. 1 is a circular doily eleven inches in diameter counting the fringe. For the benefit of those who do not know how to fringe a round doily I will quote from "Barbour's Prize Needlework Series No. 3." "Take a twelve-inch square of linen (or according to the size wanted), mark upon this a perfect circle as large as possible, then another circle an inch within. Around this stitch with the sewing-machine, using very fine thread with a very short stitch. Work with close buttonhole-stitch over the stitched line, cut around the outer line, and draw the fringe by beginning on one side next the stitched line. Draw the threads to the edge on all four sides, which will leave four triangles. Pull the threads in these one at a time from the stitched line, using a pin. Straighten out and even the fringe and the work is done."

From the center of this doily cut four leaves one and one half inches in diameter at the widest part, leaving a little space of cloth at the center and outside edge. Buttonhole-stitch around the edges, and fill with the rings, which are made as follows: Wind the thread twenty-four times around a smooth stick a little larger than a lead-pencil, cover with double crochet, and join as made in the figure shown in No. 1. There are fourteen rings in each leaf. With a fine needle and the same thread (No. 100) fasten neatly into the open spaces, filling the openings between the rings with simple lace-stitches. The illustration makes a description of these unnecessary. Other stitches may be used if preferred.

No. 2.—Wind the thread thirty times around a lead-pencil, slip off, and cover closely with double crochet. Chain seven four times, fastening with slip-stitch at equal distances around the ring. Chain three, make seven roll-stitches of twenty overs each (thread over hook twenty times) under each seven chain, making twenty-eight roll-stitches. Make two loop or knot stitches, fasten with slip-stitch between the fourth and fifth roll-stitches, two loop-stitches, slip-stitch between seventh and eighth roll-stitches. Repeat from beginning, making eight points.

Join the wheels as made at two of the points, leaving one point for the inner and

three points for the outer edge of the circle. The doily is composed of seven of these large rings, each containing six wheels. The illustration shows how the rings are joined. The centers are filled with circular bits of the linen worked in close buttonhole-stitch. For the edge work one row of loop-stitches.

No. 3.—The diamond-shaped pieces of this doily are four inches scant by two and one half inches. Each side of the hexagon in the center is one and one half inches. All edges, of course, are worked in close buttonhole-stitch.

The medallions that join the pieces are made of one and two threads, as follows: With one thread a ring of two double knots, picot; repeat until there are eleven picots; close with two double knots. With two threads a scallop of fifteen picots, with two double knots between each, beginning and closing with two double knots. Another ring (all rings throughout the pattern are alike), joining at fifth picot to fifth of first ring. Continue in this manner until there are four rings and four scallops, joining rings at the fifth picot, leaving one picot in the center.

Join the medallions to each other and to the linen at center picot of scallop. The border is a repetition of the scallops and rings, fourteen of the latter to each diamond, a ring at center scallop of medallion, with but eleven picots in the scallop preceding and succeeding this ring.

JULIA A. WILLIAMS.

### FOR THE COUNTRY SICK-ROOM

So many of the articles on cookery for the sick are filled with names entirely foreign to country kitchens, and it sometimes seems to the busy housewife that there is really nothing to offer to the invalid unless one has a well-filled purse. There are many dainty things for the sick that are daily overlooked in the search for novelties to tempt the appetite.

In winter it is harder to find material for delicate stomachs to digest than in summer, when there is a great variety of fruits and other things. Often it is impossible to hire help, so that the mother is nurse as well as general housemaid during the most trying times in the country home, and the elaborate directions found in most cook-books only make her heavy burdens heavier.

One of the most cooling drinks in case of fever is the water in which dried apples have been simmered during an entire day. Put a quart of the apples in a large crock with plenty of water, set on the back of the stove where they cannot boil, and slightly sweeten the juice as it is wanted. It is well to keep a small pitcher out of doors where it will not be too cold, and yet will not absorb the odors of the sick-room. Make a fresh supply often, as it is nourishing and little trouble.

Sometimes in cases of severe coughing a few spoonfuls of cold cream with just a little nutmeg and a dash of sugar will soothe the tired throat and send the sufferer into a



No. 3

refreshing sleep. Sweet boiled cider and fruit-juices are excellent drinks when milk cannot be used, especially the juice of blackberries. If all the bottles that accumulate in the average home were kept clean and handy during the canning season there would be little trouble in storing away many nourishing drinks for invalids.

Nearly every receipt for broth calls for fresh beef, but this is out of the question in

most rural homes. There is nearly always a supply of plump chickens that can be converted into delicious soups with little trouble. In many parts of the country there is still some game, which is always relished by the sick, but do not season it highly or prepare in an elaborate form. Soft-boiled eggs or delicately poached ones are the most nourishing food, and can always be used in a perfectly fresh condition by the country



No. 2

people, while city folks must depend on the doubtful ones found in the grocery.

Fresh scraped apple is excellent, and can be used without fear of injuring any one. Many times severe colds have been broken up by eating nothing but boiled onions and drinking plenty of water. A little of the juice of tomatoes very hot and seasoned only with a little salt and butter will sometimes tempt the invalid when everything else fails.

Of course, much of the success of these simple viands depends on the manner in which they are served. It is always money well expended to have a small supply of pretty china and glass to be used only in case of sickness. You can pick up odd bowls, cups and small dishes for a mere trifle at the china-stores, and they need not be the latest style to be pretty and dainty.

It ought to be a part of every girl's education to make the best of everything and to be prepared to meet the common emergencies of life calmly. In the midst of the trying perplexities of every-day life many a woman rises up and calls her blessed who taught her to be mistress of every situation.

HILDA RICHMOND.

### HOME NURSING

Any good physician will tell you that good nursing is more than half the battle in fighting disease. Indeed, it is often the point upon which life or death turns. If one can have a regular trained nurse in time of severe illness it is no doubt best, but in very many cases this is impossible, and the nursing must be done by members of the family. There are many simple ailments when good nursing with simple home treatment is all that is necessary.

No woman ought to go into a home of her own without knowing something about the care of the sick. This is especially true in the country, where it is sometimes hours before a doctor can be brought, and often every moment of delay adds to the danger. As "first aid to the wounded" is valuable knowledge to the soldier, so "first aid to the sick" or in case of accident should be a part of every woman's education. Every woman should be able to count the pulse and know what the normal beat should be both for children and adults; she should also have a thermometer for the purpose, know how to take the temperature, and what the normal temperature is. She should know the healthy appearance of the throat; then she could easily detect a diseased condition. She should know how to make a poultice and a

mustard-plaster, and when either of these are indicated; when cold applications and when hot should be applied.

Any reputable physician would give a talk on "first aid to the sick" if invited, and it would be far more valuable to "mothers' clubs" than some of the subjects which they discuss.

Next to the importance of knowing what to do in an emergency of sudden illness or



No. 1

The first number on the program was a song, "Our Flag," beginning,

"World fashions change, 'tis often said,  
The race by novelty is led,  
But our old flag, white, blue and red,  
Shall keep these tints forever."

An able address entitled "Our Heroes"—the soldiers of '61 and '98—evoked much enthusiasm.

Colonel Austin, the oldest veteran, read a list of the names of the soldiers who died in battle or from wounds received on the field or from disease contracted in their country's service. Then in memory of these comrades the regiment band played an impressive dirge, while the vast audience stood with bowed heads.

A choir of well-trained male voices sang Cardinal Newman's "Lead, Kindly Light."

A brilliant address on "Our Country," the land of these heroes, was eloquently delivered by our townsman, young Senator Morgan.

"America" was gloriously sung to inspiring martial music.

After the memorial service "an army supper" was served in the parlors, the tickets, at fifty cents each, admitting the bearer both to the entertainment and the supper.

Bunting in our national colors decorated the newel-post and the balustrades. A large United States flag was draped above the door, and here at the entrance stood a stern soldier sentinel, a brave young volunteer. Within a novel scene awaited the guests. Dark-brown crash covered the floor; bunting in the festive red, white and blue replaced the lace curtains at the windows. To-night only portraits of army heroes were seen on the walls. Patriotic-tinted candles furnished the only light in the room. These were thrust in the necks of bottles. They appeared, too, on the four tables spread here.

The supper was served on these tables of bare boards, not polished tops by any means; in their simplicity they bore no relation to them. The food was served entirely on tin dishes, plates and cups, with steel forks and knives, and typical army rations were provided, such as canned and fresh meats, hardtack, beans, coffee, etc.



accident is to have the things on hand to do with. I do not advocate the indiscriminate giving of medicines without the authority of a physician, but there are some simple remedies which should always be at hand. Have a closet if possible devoted to this purpose. Here have a hot-water bag and a syringe, a lamp-stove ready for lighting, a box of mustard and one of flaxseed-meal for poultice, a can of vaseline, a jar of coconut-oil, a bottle of witch-hazel and one of listerine, a bottle of peppermint and one of Jamaica ginger. Then have a supply of old, soft cotton and linen cloths, some pieces of flannel and some surgeon's adhesive plaster. The thermometer spoken of should be kept here, also a glass dropper, a small glass or rubber syringe, and a spray for the nose and throat. I always keep a bottle of "alkali and antiseptic" tablets, and find them excellent used as a spray for a cold in the head and throat.

Children should be taught to gargle the throat when they are well, using pure, cold water. They will think it great fun, and then will readily do it when they have a sore throat. I have found a solution of either witch-hazel or listerine, three parts of water to one of the extract, a good gargle in common inflamed or sore throat. It can do no harm in more severe cases, but then a doctor should be called at once. I have learned this winter that abscess in the ear sometimes follows tonsillitis, especially if the throat does not receive the proper treatment.

Children are often subject to earache, and sweet-oil and laudanum are sometimes dropped into the ear to relieve the pain. A physician tells me this is injurious, and that nothing should be put into the ear but a few drops of water as hot as can be borne, using the dropper or small syringe. Use the hot-water bag on the outside, and sometimes a mild mustard-plaster applied to the side of the neck will relieve it. If white of egg is put over the plaster it will not blister.

If you have no hot-water bag a very good way to apply heat is to make a pancake half an inch or so thick, wrap it in a cloth and apply with a thick flannel over it to keep in the heat. This is better than cloths wrung from hot water, as there is no danger of wetting the clothing, and yet the heat is moist and steamy.

If a pain in the ear does not soon yield to this treatment call a physician, as it is something more than simple earache, and neglect may result in deafness.

As an example of the ignorance many people exhibit in case of accident, a lady living in the country told me of being sent for in great haste by a neighbor whose husband had cut his foot. When she reached the house she found the man in a fainting condition from the loss of blood, and the cut foot in a bucket of warm water, which of course increased the flow of blood. She immediately laid the man on the floor, then lifted the wounded foot and held it as high as she could after bandaging it as well as she knew how. When the physician arrived he said she had no doubt saved the man's life, as with the foot in warm water he would soon have bled to death.

If severe illness comes into the family, and it is not possible to get a trained nurse, keep yourself calm and follow the directions of the physician in the most minute particulars, making no experiments of your own or suggestions of your friends without first submitting them to his judgment. Take as good care of your own health as possible, that you may give your best to the sick one. Leave your patient with some trusted one while you take the necessary rest and a little time in the fresh air every day. If you must do the most of the nursing by night as well as by day, change your underclothing every morning and evening, wearing each suit in alternation; this of itself will rest you. If you cannot trust your memory, write out the doctor's instructions. Give your whole mind to the nursing, and do not try to be both housekeeper and nurse, for it is all-important that you be at your best yourself to give the best care to the sick one.

MAIDA McL.

#### CONCERNING BEDS AND BEDDING

Recent contact with beds and bedding of an exceedingly unwholesome character is the very justifiable excuse for an article upon this topic at this time. Not that an excuse is ever needed, however, for a chapter or for many chapters on this always timely subject; and neither is there any excuse whatever anywhere under the shining canopy of heaven for so filthy and repulsive a state of conditions as is found to exist in the homes of people in any numbers in and about beds, bedrooms and

bedding. Even the direst poverty cannot excuse the sin of slothfulness and the tolerance of sickening, unsanitary conditions in clothing and bedding, for soap and water are both cheap and plentiful. Patches and even rags are honorable, but filth is unpardonable. We find an occasional housewife who is evidently sailing along under the impression that "dirt well covered up is as good as cleaned up." There's something morally wrong in the make-up of that individual.

Stopping at what is termed a first-class hotel in a large Western city a short time ago, the writer, on retiring, noted the tell-tale odor that says "old beyond redemption" that came from the bedding provided. The sheets were fresh, likewise the pillow-slips and heavy white spread, but it was evident to the olfactories that there was something stale and old about that bedding somewhere. The comforter looked a brand-new one, of crisp, dark calico. Upon getting into bed it was found that the "comforter" was a misnomer. It was anything but comfortable and inviting. It settled down as a cover about as a sheet of cast-iron would have done. Intuition told the story of the inner condition of said piece of bedding. But to make sure that conjectures were correct a number of stitches were broken (I was "taking liberties" with property not belonging to me, but felt justified in so

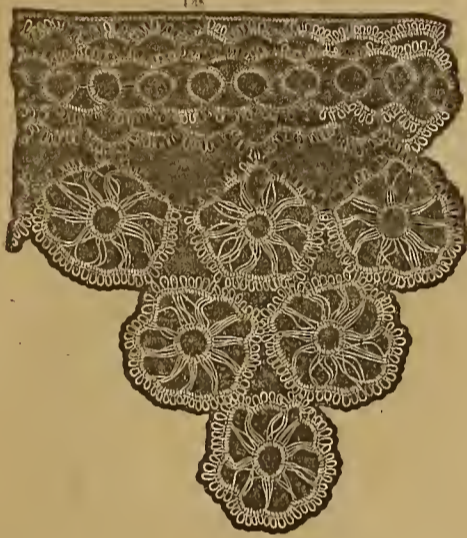

doing, as injuries(?) were repaired) and a space raveled out where the edges of the new calico covering were joined. And of all the filthy pieces of bedding ever inspected this one "capped the climax," as it were. It was "dirt well covered up," and yet the odor was too strong to be subdued. Covering up did not suffice. The entire thing should have been as speedily as possible consigned to the flames. Such bedding is not only disgraceful, but positively dangerous. Disease lurks in its every fold. The veriest tramp that roams the earth should never be offered for a bed-cover so disgraceful an affair. Yet is just such bedding a very common thing.

Very shortly after this experience, at a private dwelling, where I was entertained as an invited stranger-guest while engaged in business in that city, a similar condition of bedding throughout was met with, and endured simply because there seemed no way out of it for the time. The departure was hastened from there as speedily as possible, and the tie of friendship was not strongly cemented.

One cannot help losing respect for a woman who will have about such evidence of her shiftless and slothful nature. Good-nature and welcome cannot make up to one of even half-fastidious taste and make-up the being needlessly subjected to such discomfort. One who remains mostly at home in the cleanly surroundings of her own little home empire realizes little, indeed, of "how the other half of the world lives. One who is called from place to place in her business, going into private and hotel homes, meets with many things of a surprising nature in that other part of the world that lies so apart from her own surroundings. And it is too bad that all these unpleasant things of a needless kind should happen, for it lessens love and respect and tends to make one cynical, suspecting and uncharitable, perhaps.

A rule of a lifetime should be with every housewife, "If I can give my friend or the stranger but a crust and a cup of tea by way of food-given hospitality, I will give to the friend or stranger a wholesome, clean bed, a clean room to sleep in, and comforts, even if they be of the commonest kind." Those things, given with welcome and cheer, are all that are essentially necessary. And of such hospitality every housewife is in duty bound to dispense.

If one's business is hotel-keeping or taking boarders and conducting a boarding-house,

it is that one's business to give "value received." If some one pays another fifty or seventy-five cents for the privilege of sleeping in one of their beds for a night, it is the duty of the landlady to see that each one has a bed that not only looks well upon the outside, but that smells well and is clean and wholesome and comfortable throughout. Cotton-flannel blankets that are delicate and pretty and soft and warm are to be had for small sums. Calico is cheap and cotton bats not expensive. Comforters are quickly made, and can easily be clipped apart when soiled, the outside washed and ironed, the cotton aired and dusted and picked into fluffy form again. When said comforters have become old, leave them to the purifying forces of flames; burn dust, soil, odor and "appearance," and replace with new.

Mattresses should be covered with a partly worn quilt or a cotton-flannel blanket. This should lie between the sheet and mattress, and should be daily shaken and aired, and very frequently washed and boiled. Mattresses should be daily turned over and aired, and a heavy canvas or muslin should cover the springs, thus keeping the mattress from contact with the metal composing the springs, and keeping the dust from settling into the mattress and other bedding from beneath the bed.

And I repeat that no excuse whatever should be made for the woman who tolerates in her home uninviting beds and bedding and "dirt well covered up" anywhere.

NEDELLA HAMPTON.

#### TATTED EDGING

Make a ring of 20 p (picots), each separated by 1 d (double); draw up and tie securely. Make p three eighths of an inch long. Without cutting the shuttle-thread fasten it to the top of the two nearest p taken together; in the same place tie a thread from a spool or a second shuttle. With two threads make a chain of 1 d, 5 p, each separated by 1 d, 1 d, join to the next two p; repeat around. Work twelve wheels and join to form points as seen in the illustration.

Make the upper rows thus: Work a ring of 9 d, 3 p (make second p very small), each separated by 9 d, 9 d; close ring. Make a chain of 1 d, 7 p, with 1 d between each 1 d; repeat for the required length.

Next row, make a chain of 1 d, 9 p, separated by 1 d, 1 d. Press the d close together before fastening the chain, to make it firmer; fasten to the center p of chains in preceding row. Join this row of chains to the wheels at every third chain. Now work a row of small chains over the rings like on the opposite side, and for the next row make large chains to correspond with the opposite side, and finish with a crochet chain of six stitches between the tatted chain, and a single crochet in center of p of same.

For insertion to match repeat the upper six rows, finishing both edges alike.

The wheels may be joined for yokes, cushion-covers, etc., and the edging and insertion make a handsome trimming for the ends of a bureau or sideboard scarf.

MRS. J. R. MACKINTOSH.

#### HONITON-LACE SCARF

One of the most popular neck-pieces worn this season will be the long lace scarf, and those who are fortunate enough to do

Honiton work, even in its simplest form, will be able to fashion for themselves one of these beautiful scarfs.

The scarfs are about one and one half yards in length and about four inches wide, the body being

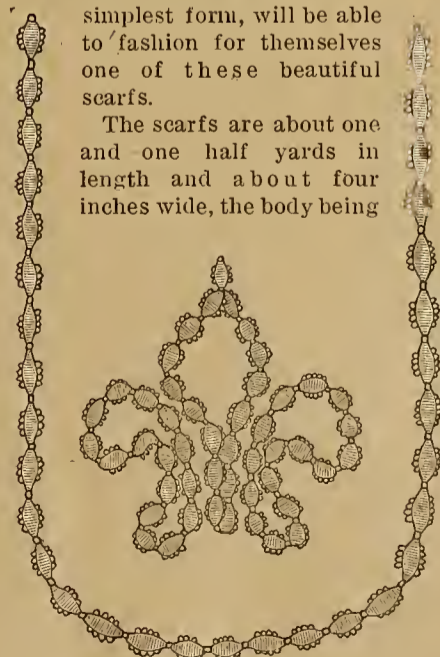

of fine cream or white Brussels net, the sides and ends being worked in some design, as, for instance, the illustration herewith. These scarfs are worn over a colored neck-ribbon, and arranged in various simple knots and bows at the throat.

EMMA LOUISE HAUCK ROWE.

#### DAINTY ORNAMENT FOR THE HAIR

One of the prettiest hair-ornaments worn for some time is made of velvet ribbon, black being more popular than colors. This ribbon is simply twisted loosely but securely around milliner's wire, which has been shaped into a graceful triple-looped bow with upstanding ends, as shown in the illustration. The ribbon should be satin-faced, about an inch in width, the quantity required being from one and one half to two yards.



EMMA LOUISE HAUCK ROWE.

#### THREE RECEIPTS

**WALLED CHICKEN.**—Clean and wash a medium-sized chicken, place it in a deep kettle, cover with boiling water, and cook slowly until tender. Remove the chicken and broth to a crock or large bowl, and set aside to cool. When cold free the chicken from skin and bones and cut into suitable pieces for serving. Pare and boil enough potatoes to make three cupfuls when mashed, beat them very light, adding cream or milk and a little salt and pepper, and set the dish where it will keep warm. Into a saucepan put two tablespoonfuls of butter, one finely chopped onion, three slices of carrots and a little finely cut parsley, and let simmer for ten minutes. Moisten two tablespoonfuls of flour with a little of the chicken broth, add this with a pint of the broth to the mixture in the pan, stir well, and let simmer for five minutes, or until it thickens. Put in the pieces of chicken and place where it will keep hot without boiling. Beat the whites of two eggs to a stiff froth and mix with the mashed potatoes. Place the potatoes around the edge of a platter like a wall. Beat the yolks of the eggs, spread over the top of the wall, put in a quick oven to brown, pour the chicken in the center, and serve with a garnish of parsley or water-cress.

**SWEETHEARTS.**—Make some puff-paste, roll it into a sheet one fourth of an inch thick, and cut out with a heart-shaped cookie-cutter. Place in a pan, sprinkle a little sugar over them, and put in a quick oven. When baked to a feathery lightness and of a pale bronze remove from the pan; when cool spread some nice jelly over half of the hearts, place the others over the jelly, dust with powdered sugar, and serve.

**NEAPOLITANS.**—Make enough puff-paste for two pies, roll out half an inch thick and cut into strips three by one and one half inches. Bake in a hot oven. When cold spread half of the strips with jam or jelly; lay the others over with the jelly between. Cover the tops with frosting.

MRS. J. R. MACKINTOSH.

#### WHEN THE GIRLS WORE CALICO

There was a time, betwixt the days  
Of linsey-woolsey, straight and prim,  
And these when mode, with despot ways,  
Leads woman captive at its whim,  
Yet not a hundred years ago,  
When girls wore simple calico.

Within the barn by lantern-light,  
Through many a reel, with flying feet,  
The boys and maidens danced at night  
To fiddled measures, shrilly sweet,  
And merry revels were they, though  
The girls were gowned in calico.

Across the flooring rough and gray  
The gold of scattered chaff was spread,  
And long festoons of clover hay  
That straggled from the loft o'er head  
Swung scented fringes to and fro  
O'er pretty girls in calico.

They used to go a-Maying then,  
The blossoms of the spring to seek  
In sunny glade and sheltered glen,  
Unweighed by fashion's latest freak,  
And Robin fell in love, I know,  
With Phyllis in her calico.

A tuck, a frill, a bias fold,  
A hat curved over gipsywise,  
And beads of coral and of gold,  
And rosy cheeks and merry eyes,  
Made lassies in that long ago  
Look charming in their calico.

The modern knight who loves a maid  
Of gracious air and gentle grace,  
And finds her oftentimes arrayed  
In shining silk and priceless lace,  
Would love her just as well, I know,  
In pink and lilac calico.

—Hattie Whitney, in *Munsey's Magazine*.

[HOUSEHOLD CONCLUDED ON PAGE 17]



## A FAIR FIGHT

By Mattie Dyer Britts

## CHAPTER III.

MRS. PEARSON recovered sufficiently to sit up and arrange their plans in an hour more. It seemed odd to say "their" of those who were so recently entire strangers, but such experiences as they had passed through draw people very near to each other, and both Virgie and the old lady felt that they were not strangers at all. As to what Herbert Begole thought it would not be very difficult to guess.

Some of the rescued travelers were leaving Onawa by the afternoon trains, but Mrs. Pearson thought it would be better to rest there for the night and resume their journey in the morning. None of them cared to try the river again so soon, and Virgie was sure she would never wish to be on the water for another trip.

Mrs. Pearson desired her to stay and go on to Omaha with her, and as Sue was coming down to Onawa, and she really did not like to leave the old lady alone, Virgie decided to do so.

"It will give me time to get money from papa, too," she said. "Even shipwrecked people can't travel without money."

"You need not be uneasy on that head, my dear," said Mrs. Pearson. "I had my pocket-book in my bosom, and beyond a little wetting it is not hurt. Part of the money is in gold, too, and of course water did not injure it. I consider myself your hanker until you hear from your father. I feel, in any case, that I can never repay your kindness to me, and you only add to it by consenting to wait until I feel able to go further."

"I should not feel that I was doing right to leave you," said Virgie. "When we get to Omaha I shall insist upon your going out to Ashland and spending a few days with me before going to Atchison."

"Well, we will see about that later," answered Mrs. Pearson, smiling. "Perhaps I shall not be very hard to coax."

Sue came down by the first train from Sioux City. Virgie was going to meet her when Mr. Begole came from the door of the gentleman's waiting-room to speak to her.

"I am anxious to be in Omaha to-night," said he, "so I am going on by this train, and must bid you good-by."

"I am sorry to see you go," was Virgie's frank answer, as she gave him her hand. "I hope we shall meet again some day."

"We shall meet—and that before very long—perhaps sooner than you think," he answered, keeping his dark eyes fixed on her face. "May I keep your ring until then, Miss Van Gillen? It is an odd thing to ask, but I have a reason for asking it, and I can assure you it will be safe in my hands."

"You may keep it," said Virgie, wondering if she was doing a very foolish deed in consenting.

"Then good-by, and God bless you!" said Begole, very earnestly, pressing the small hand he still held.

"The same to you. Good-by!" said Virgie. He walked away, and she hastened to the little station, thinking, "Well, I have heard that sometimes in life a year might be crowded into a day. I know now that it is true. This Sunday counts for a whole year in my books."

Sue was overjoyed to find her friend safe and sound, and deeply interested in the story of their escape. Of course, she was introduced to Mrs. Pearson, and found, to the surprise of all of them, that the old lady had been an intimate school friend of Sue's mother, a fact which made them feel still less like mere strangers. Virgie was sorry Mr. Begole had gone, so that Sue could not meet him, but both she and Mrs. Pearson spoke warmly of his noble courage in saving them from a watery grave.

"It was an awful time, and I wonder you ever came out of it alive. Lost all your clothes, didn't you?" said Sue.

"All I had with me—we all did," was Virgie's answer. "There is one thing seems so odd, Sue—that I should have chanced to put on my black silk skirt just before the fire. It helped keep me up in the water more than any dress could have done."

"It was lucky you had it," said Sue; "but oh, Virgie, see, you have lost your diamond ring! Did it slip off in the water?"

"I think it must have done so," was Virgie's answer; and as she had to stoop just then to pick up something from the carpet, that might have covered her momentary confusion and explained why her sweet face went so red. "I don't mind the ring since I got off with my life," she added.

"Well, it was a pity to lose it; you always thought so much of it, and you know your father gave it to you on your eighteenth birthday."

"Yes; but it can't be helped now."

Mrs. Pearson thought it was very nice in Virgie to try to bear the loss of her jewel so bravely when she must have valued it highly, and made a mental resolve to replace it with one even more elegant, as a slight testimonial of her own gratitude to the dear girl who had stood by her so nobly.

"I wouldn't have them know where that ring is for a fortune!" thought Virgie. "Let them think it is lost, and then if I never get it back—but there, I am perfectly sure I will, when he gets ready to give it, so I won't worry."

If it was a suspicious circumstance that the gentleman in whose breast-pocket the ring at

that moment snugly reposed already needed no other designation in Virgie's mind than "he" she did not know it in the least.

Sue stayed at Onawa that night, and left for her home the next morning a few minutes after the train which carried Mrs. Pearson and Virgie to Omaha. Virgie felt well and strong again, but Mrs. Pearson still looked so weak and white and had evidently received such a shock to her nerves that the young girl urged her not to undertake the longer ride to Atchison, but to run out to Ashland with her and rest a day or two at her home.

Mrs. Pearson consented to do so, and Virgie left her sitting in the waiting-room while she herself went to the telegraph-office to send her father word to meet them in the double carriage, for she was bringing a guest. Finding that they had an hour to wait before the train for Ashland went out she thought she would take a cup of hot coffee in to her friend, in hopes it would prove refreshing. She was crossing the vestibule to ascend the great stairway and go to the dining-room when she found herself face to face with Mr. Begole, who was just coming down the stairs. His handsome face lit at sight of her, and he hastened to her side with outstretched hand.

"I am very glad to meet you again," said he. "How are you this morning?"



"SHE FOUND HERSELF FACE TO FACE WITH MR. BEGOLE"

"I believe I am none the worse for yesterday's adventure," answered Virgie. "How is the hurt arm?"

"It does not pain me very greatly so far," he said, lightly. "I suppose the worst has not yet come. And the old lady, how is she?"

"Quite shattered, I am afraid. It will be a wonder if she gets off without serious sickness. I am taking her to my home near here for a few days' rest before she goes on alone."

"That is like your kind heart. I wish I was Mrs. Pearson," he said, laughing.

"Well, I wish I had the opportunity to take care of you, Mr. Begole. I have not forgotten how you got that broken arm. If you had left us to take care of ourselves you could have escaped entirely."

"No, I could not. I should have had something much more dreadful than a broken arm to think of the remainder of my days. Miss Van Gillen—"

He stopped abruptly and hesitated.

"Say what you wish," said Virgie.

"I hardly know how; but I don't want to deceive you in anything. I, too, am going direct from this city to Ashland."

"You are?" Virgie's eyes were wide with surprise.

"Yes, I am. You may remember I told you we might meet again sooner than you imagined. I wish—well, there is something of vast importance, to me at least, which I would like to say to you. Can you spare me a moment or two? I will not impose upon more of your time."

They were ascending the broad stairway, and Virgie paused at the top.

"Wait for me just a minute, please. I will see if Mrs. Pearson can spare me."

She went down the vestibule and glanced in at the door of the ladies' room. Mrs. Pearson was lying easily on one of the soft couches, her eyes closed as if in sleep. Virgie went back to Mr. Begole, who stood at the top of the stairs.

"She seems to be resting nicely. I can leave her for a short time."

"Then please walk out on the viaduct with me. I won't keep you long."

They went out and stood leaning upon the iron railing, looking down upon the busy traffic going on over the spider-webs of tracks below. Mr. Begole spoke at once, or rather he was about to speak, when she noticed that the sling in which he carried his arm was slightly disarranged.

"Wait, let me fix it," said she; and she put it straight with soft touches which brought a look into the young man's eyes as if he would have been glad to say things which he did not dare—as yet.

"I hope you had it well set," she observed.

"Yes; a fat little doctor in the village hack in Iowa fixed it up for me. Seems to have done it rather well, too. But it was not of my arm I wanted to speak to you. Miss Van Gillen, I want you to make me a promise—a very singular promise."

"I cannot until I know what it is, Mr. Begole."

"You shall soon know. I told you I was going to Ashland—your home. I shall not stay over a day or so this time, but in two or three weeks I am coming back, and then I am sure we shall

you. Though, as far as that goes, I would not consent to let any other person in Ashland know of it, I am perfectly willing to give you as reference some of the best names in Grand Island, and you may write to them if you care to."

"I do not care to. I do not believe I am making a mistake in trusting you, Mr. Begole."

"Thank you again. God bless you, dear girl! Forgive me, I could not help saying that. Such goodness as yours wins a man in spite of himself. The thing is, will you give the promise? Or is it too late? Have you told Mrs. Pearson my name?"

Virgie thought a moment. She could not say to him that the little episode of the ring had somehow made her reluctant to speak his name, but she could and did answer:

"No, on thinking it over I am sure I have not. She has been so ill that I have not worried her with much talking at all. We have spoken of you, but it has always been as 'that young man.' I did mention it to my friend, Miss Winston, but Sue will not be in Ashland, and her letters no one reads but myself."

"Then our little secret is all right. Now understand me, Miss Van Gillen, I do not mean that this promise shall always hold you. The day will come, I hope very soon, when you shall be at liberty to tell all you know. But for the present—and the day will come, too, I firmly believe, when you will be glad that you promised me—I want you to be introduced to me just as any other person in Ashland, and not to give any one the slightest hint that I was with you in our shipwreck. My part of it you may trust to me. Will you promise?"

Virgie looked up into his manly, true face and answered, without the least hesitation:

"I will! I do not understand the mystery, but I give the promise, and I will keep it until you yourself see fit to release me from it."

"Thank you. I trust that day will not be long in coming—it may be very near, it may not. Miss Van Gillen, there are times when words are little better than being dumb. This is one of them. I can't say anything beyond that cool 'I thank you,' but from this time my life is devoted to being worthy of such a promise from such a girl."

"Now you know me as little as I know you, Mr. Begole."

"No, I know you better, for I had heard of you, though I did not dream it was you whom I met on the steamer."

"Why, the mystery grows!" said Virgie, smiling.

"Well, let it be a little mystery for the present. Now we must say good-by, for it will soon be train-time. I shall probably not see you on this trip, but when I come to Ashland again—then I hope for better things. Miss Van Gillen, you have trusted me—remember I trust you, and it is a matter of importance."

"You may trust me, Mr. Begole."

"I know it. Perhaps it is better that Mrs. Pearson does not see me, so I will not offer to help you on the train. Good-by, until we meet again."

"Good-by," said Virgie, simply.

She went back into the waiting-room and he remained out on the viaduct. She had still time to give Mrs. Pearson the cup of coffee and help her arrange her toilet for the train. Very soon they were seated in the cars, moving swiftly out over the plains toward Ashland. Somehow it was a comfort to Virgie to know that Mr. Begole was on that train, too, though she did not see him, except once, when they stopped at a small station he passed down the platform and lifted his hat to her, with a warm smile and a glance of those dark eyes which she could not forget.

"If anything happens it is a comfort to know we have help at hand—that is why I am so glad he is near," she told herself, with a glance at Mrs. Pearson, to be sure that she had not seen and recognized him. "A queer thing I have done, that is sure! He need not be afraid I will tell anybody. I wouldn't for the world! He did not say one word about the ring, but it is all right, and so is he. A woman can keep a secret, after all, as folks will find out some day. I won't even give Sue the slightest hint that I have one. Oh, what a journey this has been! Shall I ever be sorry I took the steamer instead of the train? I'm not sorry now, at least. I had rather have been through that awful time in the water than not. Oh, nonsense, what a goose I am!"

She abruptly broke off her reverie and devoted herself to making Mrs. Pearson comfortable for the rest of the way.

When they reached Ashland she could not help a sly glance around to see if Mr. Begole was visible; but he was not, though she had a curious feeling that from some unseen point of view he was looking at her and saw her meeting with her father.

## CHAPTER IV.

Great was the excitement when Virgie and her guest arrived in Ashland. Mr. Van Gillen himself came to the station to meet them, and extended a warm welcome to the lady who, he soon learned, had shared his daughter's peril and been saved with her from so fearful a fate.

"And so you did not learn the name of the young man who rescued you?" he asked, as Virgie related the story while they drove home.

Somehow Virgie had to bend down to arrange her skirts just then, and he did not see her face as she answered:

"Dear papa, we were not taking time to think of names out there in the water. I meant to ask his name when we came to our senses in Onawa, but somehow I didn't." Which was quite true, as he had given her his name without asking.

"Well, I'm sorry. I should like to do something real handsome for that young man," remarked the merchant.



"We may see him again some day, papa. I'm quite sure I should recognize him anywhere, and then you might reward him."

"That's very unlikely, daughter. But if the chance ever comes it will not escape me. He has placed me under an obligation that I can never repay. I shouldn't care to live long if I had lost my runaway little girl." His strong tones trembled and he did not try to talk further. There was indeed no opportunity, for they were just at the gate of the dear old home Virgie had thought she might never see again. It was a fine old place, with grand shade-trees and beautiful shrubbery in the grounds, wide verandas about the spacious dwelling, and within cool rooms and delightful halls full of cozy nooks and corners and furnished with every modern appliance for beauty and luxury as befitted the home of a prosperous Western merchant, who had too much good sense to wait until it was almost time for him to die before he really began to live.

Aunt Maggie, "fair, fat and forty," her rosy face a mixture of distress at Virgie's misfortunes and delight at her safe return, was on the doorstep to greet them, and flinging her plump arms about Virgie's slender form, she cried and laughed in the same breath:

"Oh, my poor, dear child! I am so glad to get you back! Oh, what an awful time you have had! How in the world did you stand it? Who got you out? Come right in, both of you, and tell us all about it! And, oh, Virgie, you know you laughed at me for saying something would happen, and what do you think now?"

"I think you are the dearest old aunty in the world if you won't squeeze me quite to death!" answered Virgie, laughing. "I want to introduce you to my dear friend Mrs. Pearson, who has come home with me to rest a little after our adventure."

"I'm as glad as can be to see you, Mrs. Pearson," was Aunt Maggie's greeting, as she held out both hands. "That child didn't tell who I am, in her hurry, but I'm Maggie Kelly, and I have my hands full, I tell you, training her up in the way she should go! Do come right in; you look fit to drop, and supper will be ready in five minutes. Come right in!"

She led the way, took off Mrs. Pearson's bonnet with her own kind hands, and showed her to a spacious upper chamber, where fresh water and clean towels were waiting for them to remove the dust of travel.

"Now come right down as soon as you are ready," she said. "I know you must be starved, so I'll run down and see that Jane has supper on the table immediately. We want you to feel yourself entirely at home with us, for hospitality is the law in this house."

"I can well believe that!" was Mrs. Pearson's reply. "But please, dear Miss Kelly, do not put yourself to the least trouble on my account."

"Oh, I won't! Don't you worry over that a minute. But I do hope a good cup of coffee and a good night's rest will set you up and make you look less like a ghost than you do now, though it isn't a bit of wonder, sure, and I'm astonished that Virgie don't look worse than she does. What did she say the young man's name was that got you off the boat?"

"I am very sorry to say that in our fright we did not learn it, nor have we the least clue to where he belongs," said Mrs. Pearson, calmly certain that she spoke only the truth. "I wanted to do something for that young man, and now I am afraid I shall never have the chance."

"Well, it is a pity. I know Jason will think so, too. I'd be mighty glad to shake hands with him myself. There, now, I must run and see after Jane. Come right down now, and don't wait for any extra dressing."

"Thank you; I will be down directly," answered Mrs. Pearson, with a smile at the thought that she was not likely to dress much without her haggage. "I am glad now that I sent my trunk down by the railroad," she thought, "or I should be minus all my best clothes. But I shall not repine when a kind Heaven has sent me such pleasant friends—one of them with the face of my lost Virginia. I do not mean to lose sight of this dear girl. She gives me a new object in life, so I can but bless the day when I met her, in spite of its dangers."

She made what little toilet she could under the circumstances, and went down to the parlor, where Aunt Maggie waited to take her to supper. The little party was soon seated at the generous table, set with sparkling glass, dainty china and glittering silver, and spread with fragrant coffee, rich cream, light rolls, delicately broiled chickens, amber jellies and rich fruits, to say nothing of the snow-frosted cake, Virgie's favorite kind, over which Aunt Maggie had heated herself in the kitchen that warm morning.

It was as Virgie took her cup of coffee that Aunt Maggie's eyes fell on her soft white hand, and she exclaimed:

"Why, Virgie, you have lost your diamond ring! Did you drop it in the river?"

"It must have slipped off somewhere, aunty, for I am sure I had it on when we started out to dinner on the boat," said Virgie, her face coloring, but hardly enough to attract their particular notice.

"And you lost it! Now, that is a pity! I don't see how you can take it so easy, child!"

"Perhaps I don't take it as easy as you fancy, aunty; but when one has been where we have one can't worry much over a trifle."

"A trifle! Well, it strikes me I shouldn't call a ring which cost a cool sixty dollars 'a mere trifle!'" cried Aunt Maggie. "I think it is an awful pity you lost it!"

"So it is, sister," said Mr. Van Gillen; "but the child is quite right—it is not to be thought of beside her precious life. Money can buy another ring; it could not buy me another daughter." His strong tones quivered again, and he could

hardly add, "So don't let's fret about the diamond when we have not lost our pearl."

"Bravo, father!" cried Virgie, clapping her hands merrily. "I did not know you could pay such a pretty compliment! Thanks ever so much. I won't ask you to buy me another ring now, though, unless business is just too good for anything this season."

"Oh, it's been pretty good so far," said Mr. Van Gillen, "but I don't know how it will hold out. There's a young whipper-snapper of a fellow—some smart Yankee, for all I know—who talks of trying to break me up, or down, I don't know which." He gave her a good-humored smile, which told her that he was not worrying himself greatly over the new-comer.

"To break you up, papa?" asked Virgie.

"Oh, yes; he wants to rent the Willard block and undersell me. I think he'll have a good time, if I don't undersell him, though."

"Yes, I remember now. Aunt Maggie wrote me something about it. But don't you worry, papa; you can afford to let him sell all the goods and go out of the business yourself whenever you want to."

"Perhaps; but I don't happen to want to," remarked the merchant, dryly. "I fancy if that young man comes here he may look for a pretty warm time, and some competition, even if my notions are 'old-fashioned' as to running business."

"Who said they were, papa?"

"I'm told that he did to some persons he saw when he looked at the block. I didn't see him myself—think I can continue to exist if I never chance to set eyes on his pretty mustache and dandish clothes."

"Why, papa, I thought you had never met him."

"I have not. That's only my idea from what I have heard of him."

"What is his name, papa? Where does he come from?"

"I don't know where he's from; his name, well, I did hear it, but it has escaped me just now. It doesn't matter, anyway, darling; we won't care about business affairs the first evening we have you home safe, and they would not be very entertaining to our guest, either. Tell us the particulars of the accident. Your first account was so hasty that I didn't half take it in, and am ready to hear more."

"I haven't heard it at all," said Aunt Maggie, "except the little bit in the papers and the short note you sent us from that place out in Iowa yesterday afternoon."

"You got it then, aunty? I wrote as soon as we decided to stay over night, and thought it might reach you before we would."

"Yes; it came in this afternoon's mail, about an hour before you got here. Now let's hear the whole story."

Virgie and Mrs. Pearson gave as detailed an account of the wreck as they were able, and again they all regretted that they had not learned the name of their brave young rescuer. That is, all but Virgie. No one noticed that she did not say a word on the subject, but rather tried to turn it upon something else.

When Mrs. Pearson was preparing to put on the dainty cambric gown which Aunt Maggie had laid out in her room that night she said to herself:

"I see that if I am going to give Miss Virginia a new ring I must be getting it before long, or her father or aunty will be ahead of me. I will see what can be done here, and if I can find anything suitable I will send home for more money. If I can't, it shall be the first thing I buy when I get back to Atchison."

It was several days before Mrs. Pearson was able to go "down town," as they called it in Ashland, even in a comfortable carriage. She was not strong at her best, and as she was something over sixty-six years old it seemed little wonder that the shock had been almost too much for her. During those few days the little circle began to grow very well acquainted with each other. Virgie heard all about the Virginia of the years gone by, whose image she was, and Mrs. Pearson learned that she had made no mistake when she decided that a sweet disposition lay behind the Nebraska girl's sweet face.

Mr. Van Gillen came home to dinner a day or two after the travelers got home and reported that the young man who wanted to rent the Willard block had been in town, but the deal for the block had not been closed yet.

"Seems as if he didn't stay long," said he, "so I don't know what he thinks of the prospect. I know what I'm going to do. I am going East next week and lay in my stock of fall goods now while things are cheap. They'll go up like a rocket by the time frost comes. Then we'll see who can afford to sell the cheapest. It may be that I will break him up instead of his breaking me down."

Virgie was sorry to find her father so set against the new-comer, but she knew him too well to argue with him while he was angry. As Miss Maggie said:

"When Jason Van Gillen gets a notion into that stubborn head of his all creation couldn't get it out, and there's no use trying!"

Two or three weeks went by and there were no signs of industry about the Willard block. Virgie and Miss Maggie began to hope that the young man had found no encouragement and had given up his project, so that Van Gillen's might remain, as it had long been, the sole dry-goods house in the east end of town. There were two or three others, but they were, in town parlance, "over the hill," and patronized mostly by the factory people in that region, while Van Gillen's was the emporium "par excellence" of all the stylish and wealthy folks of Ashland.

Mrs. Pearson remained a week with her new friends, then returned to her home in Atchison, with a promise of a visit from Virgie very soon. When she had been gone a few days there came a little parcel by registered mail, addressed to Miss

Virgie Van Gillen. Upon being opened it was found to contain a tiny velvet box within a box of white paper, and inside the last receptacle, upon its silken cushion, lay a lovely little ring set with one fine diamond, and in the box a tiny paper bearing the words, "Louise Pearson to Virginia Van Gillen, as a very slight token of love and gratitude," and the date, "June 11, 18—."

"Oh, what a beautiful gift!" was Virgie's exclamation, as she slipped the costly jewel over her finger and found it a perfect fit. "How sweet that was of her, Aunt Maggie, wasn't it! And so unexpected to me, too!"

"It's a little beauty!" said Aunt Maggie. "She has intended it to replace the one you lost in the river, and I declare it is even prettier. Take it to the library and show it to your papa."

Virgie went to the library, looking at the ring and wondering if she ought to feel like a deceitful little wretch, in that she knew the ring was not in the river at all and not even lost.

"No, I don't know that," she said to herself. "It may be that I shall never see it again—and yet I don't believe, and won't believe, that he is a rascal. No, I shall wait for awhile. He said he would return after two or three weeks, but he certainly won't come until his arm gets well, and that ought to take nearly or quite a month. I'll wait and trust him a little longer."

Mr. Van Gillen admired the ring greatly, and told Virgie she must write her very prettiest note of thanks to her new friend.

"Oh, I'm going to!" said Virgie, brightly. "Wasn't it nice of her? Though I would love her just as well if she had not sent me anything, for I never knew a dearer woman. I'll write the note now, papa, and you can take it when you go down town."

She tripped away, leaving her father to think, as he often did, of the strange things which had led to the friendship with Mrs. Pearson. Mr. Van Gillen was not a religious man, but not a day passed now that he did not thank God humbly for sparing to him his "one sole daughter," the darling of his declining years. His aim had always been to make her happy, and he resolved anew that nothing he could do should ever be lacking to brighten her young life as she had always brightened his.

Three days after the ring came Mr. Van Gillen came home to dinner and told Miss Maggie and Virgie that the new dry-goods man had come to town, and he supposed would go at once into business.

"But I sha'n't fret my head over him," said he. "If he let's me alone I'll let him alone. If he don't, there will be war in the camp, and the best fellow wins."

"Now, you just take it easy, Jason," counseled Miss Maggie; "that's always the best way. I dare say all will come out right in the end."

Virgie was not conscious of any particular interest in the dry-goods man, so she had forgotten all about him, when, as the three were out driving after supper that evening, Mr. Van Gillen suddenly turned to her and Miss Maggie, who had the hack seat in the carriage, and said:

"Girls, if you want to see the new merchant of the Willard block, look over there at the Ramsay House. He is standing on the steps with a newspaper in his hand."

More to gratify her father than from any other motive Virgie looked in the direction he indicated, and actually dropped back against the carriage-cushions speechless and almost faint, for the features of the only man who stood on the Ramsay House steps, the man who held the newspaper, were the handsome features of Herbert Begole, the hero of her maiden dreams, the man who had saved her life.

[TO BE CONTINUED]

#### FOR VALUE RECEIVED

So many little mouths to feed,  
So many little shoes to buy,  
So many tales of woe to heed,  
So many things that sorely try.

So many little arms that cling  
About me softly, tenderly;  
So many happy songs to sing,  
So many loving smiles for me.

So many happy looks from eyes  
That make the busy world so bright,  
So many little prayers that rise  
To Him above for me, at night.  
—Exchange.

#### FRENCH TIME STANDARD

The French Chamber last year passed a bill adopting the meridian of Greenwich as the standard meridian for French calculations, though the framers of the measure made no reference to the name Greenwich for fear of arousing international jealousy. This bill, it is hoped, will become a law this year. At present Paris time is nine minutes and twenty-one seconds faster than Greenwich time, and all French calculations, maps, etc., are based on this standard. The entire civilized world saving France now accepts the meridian of Greenwich. To the United States is due much of the credit for this practical unanimity. In 1884 a commission was convoked at Washington at which delegates from twenty-two countries were present, and the meridian of Greenwich was agreed on for the prime meridian, France being the only country to reject the arrangement. The French delegates wanted the prime meridian to be that of Bering Strait or some other non-political point, but the necessity of having this meridian pass through some first-class astronomical observatory, such as Greenwich, was too evident to allow this. French obstinacy in clinging to the meridian of Paris makes a lot of trouble in scientific calculations, and it would be a relief if the discrepancy could be removed.—The Pathfinder.

#### CHILDREN'S IDEAS OF BEAUTY

In one of the lectures given yesterday at the winter meeting at the College of Preeceptors, a strange light was cast upon the esthetic ideas of the small child. The lecturer, Miss Isabel Rhys, of the Manchester High School, contributed incidentally an account of an experiment of her own. She gave her class of about thirty very young children five minutes to think of the most beautiful thing they ever saw, and at the end of that time recorded their answers. The human element was entirely ignored, not one of them referring to any human face. Five children mentioned the moon and stars (one stipulating that it must be the full moon), two the sun, and one the setting sun. Two chose flowers, two certain scenery, two birds, and two (both of them lazy) fell back upon the last object-lesson; namely, starfish and sponge. The following joys forever received one vote each: the snow, the rain, a butterfly, the Union Jack, a tiger's skin, salt, silver and gold, barracks, and brooches and pink silk.

In some cases a revision was desired the next day. The girl who at first approved the rain wished afterward to change it for a house with snow dropping from it, a little street in front, and a post-office at the end. The boy who admired barracks next day preferred Haddon Hall. Another boy, who at first suggested a ship with sails, withdrew this in favor of a steamer, which he thought was nicer because of smoke. Second thoughts were an improvement in the case of another, whose first choice of a steam-engine (with the qualification, however, that it was running along in the sunshine) was withdrawn for a country scene he remembered, where there was a stream with golden bracken and the sun shining upon it. The children who were thus interrogated were not city arabs, but came from well-to-do homes. Yet one of them actually said that the most beautiful thing she had ever seen was a little toy house, "where a woman was sitting by the window and a man coming up to the door; the woman wouldn't let the man in because he was drunk." A little boy who had been taken to many beautiful places most preferred a glass hall which, when shaken, produced the appearance of a snow-storm inside it; and a girl who had lived for three years under the shadows of one of our noblest cathedrals set in the first place a monkey at the Zoo.—Westminster Gazette.

2.

#### WHERE MOTHER-OF-PEARL COMES FROM

The mother-of-pearl fisheries of the Red sea extend the whole length of that water. About three hundred boats are employed by the Arab tribes who are engaged in the work—open, undecked boats, of from eight to twenty tons burden, carrying a lateen sail, manned by crews of from five to twelve men, each provided with a number of small canoes. There are two fishing seasons of the year—one of four and the other of eight months—during nearly the whole of which the boats keep the sea.

Fatal accidents are said to be unknown among the divers, and they are remarkable for their strength and good health, considering the nature of their work.

They dive between the ages of ten and forty years, and the practice is said to have no ill effects. Operations are conducted only in calm weather, when the shell can be discovered by the eye at a depth varying between seven and fifteen fathoms. Of late years empty petroleum-tins, with the ends knocked out and a sheet of glass inserted in one end, have been used to assist the eye. The glazed end of the tin is submerged under the sea, when a much clearer and deeper vision of the sea's floor is thereby obtained.

During the last twenty years the find is said to have diminished, owing to the dearth of shells, from ten to twenty per cent in quantity. Shells brought to Jeddah for sale are disposed of at public auction in heaps of about half a hundred-weight each. As preliminary inspection is not allowed the bidding is purely speculative. The bulk of the shells is sent to Trieste, some to London, a few to Havre, and some of the finest and largest shells are purchased for exportation to Bethlehem, where they are engraved and sold to the pilgrims to that famous spot.—Evening Post.

2.

#### PARIS AND LONDON

As it seems that every one I meet nowadays is going to the Fair, I venture to present a few good working comparisons between Paris and London.

Paris rises early, London late.

Paris takes two meals a day, London four.

Paris at meals is sociable, London isolated.

Paris drinks coffee and wine, London tea and beer.

Paris dips her bread in her coffee, London eats her slice and drinks her tea.

Paris eats boiled meat and fried potatoes, London roasted meat and boiled potatoes.

In Paris the fork is held in the right hand, in London in the left.

In Paris soup is taken from the end of the spoon, in London from the side.

London, says Voltaire, has a hundred religions and one sauce, Paris has a hundred sauces and no religion.

Paris wears white trousers, London white waistcoats.

In London churches the congregation sing, in Paris churches they remain silent.

Paris opens its museums on Sundays, London on week-days.

And finally, in case some of my readers should find themselves short, for of a truth air promises to be about four dollars a pint there during the Exposition:

Paris calls the pawnbroker "my aunt," London "my uncle."—Exchange.



CANADA'S PEAT-BOGS

The best authorities say there are one hundred thousand acres of undeveloped peat-bog in Ontario, principally in the counties of Perth, eight miles north of the city of Stratford, on the Grand Trunk railway. Here is a swamp of forty thousand acres, with a depth of peat-bog that varies from a foot to twenty feet. About a year ago the Canadian Peat Fuel Company was organized, and early in the summer active operations to put the fuel on the market began.

The process of manufacture is as follows: The peat is cut and air-dried, after which it is pulverized by being passed through a picker and automatically deposited in a hopper which feeds a steel tube about two inches in diameter and fifteen inches long. The pulverized peat is forced through this tube by pressure, and formed into cylindrical blocks three inches in length and almost equal in density to anthracite coal. The fuel is nonfriable and weather-proof by reason of its solidity and the extreme glaze imparted to it by frictional contact with forming-dies. The inherent moisture of the peat is reduced to twelve per cent of the mass. In weight it compares with coal as follows: Eighty-three pounds a cubic foot of peat equal seventy-three pounds of bituminous or ninety-three pounds of anthracite coal.

It is claimed for peat that it is superior to coal in its absolute freedom from sulphur and the absence of smoke, soot, dust and clinkers during consumption. In a great measure this solves the problem of furnishing a cheap, clean, uniform and reliable fuel for all domestic purposes, as it is equally serviceable for grates, stoves, cooking-ranges and furnaces, giving a long, bright flame and intense heat almost from the moment of ignition. It has been tested in locomotives with excellent results, showing that the thermal value of one hundred pounds of peat is equal to ninety-five and fifteen hundredths pounds of coal. It was also tried at the power-house of the Metropolitan Street Railway, Toronto, and gave great satisfaction. The heat produced was much greater than that of coal, but it was eight per cent deficient in lasting power. It requires but little draft, and burns best in a shallow fire-box.

The machinery used in manufacturing peat-fuel is not expensive, and requires but little attention when in operation. The company claims that when these works are fairly started it can produce compressed peat-fuel for sixty cents a ton.—Buffalo Express.

MOVING A CIRCUS BY RAIL

"Previous to 1872 the 'railroad circus' was an unknown quantity. Like all other circuses of that day, the big show of which I was the manager traveled by wagon. During our first season our receipts amounted in round numbers to four hundred thousand dollars exclusive of side-shows, concerts and candy-stands. Of course, we showed in towns of all sizes, and our daily receipts ranged from one thousand dollars to seven thousand dollars. Finding that the receipts in the larger towns were frequently twice and three times as much as in the smaller ones, I became convinced that we could at least double our receipts if we could travel only from one big town to another. This was my reason for determining to move the show by rail the following season.

"To this end, therefore, I at once telegraphed to the superintendents of the different railroads, asking if they could accommodate us and guarantee to get us to the various towns in time.

"After a great deal of correspondence I went to Philadelphia and interviewed the officials of the Pennsylvania Company. I finally made arrangements with them.

"After much preparation we eventually fixed upon New Brunswick, New Jersey, as our first loading-place. We were new at the work, and so commenced loading at eight p. m., and finished the job at eight a. m. with no extraordinary incidents except the breaking of one camel's back—the creature having the misfortune to slip off the 'runs.' From New Brunswick we went to Trenton, where I had hired Pullman cars for our performers and band, and cheaper cars for our laborers and other attaches.

"It was quite laughable, during the earlier portion of the season, to watch the expressions on the faces of our performers when they came on to join us and were shown the Pullman cars which were to be their homes for the next six months. 'It is too good to last,' remarked one. 'The expense will break the show,' said another."—W. C. Coup, in the Saturday Evening Post.

FOREIGN IMMIGRATION

Foreign immigration into the United States, the volume of which was diminished after the financial difficulties of 1893 and 1894, has resumed its former dimensions and is now about 300,000 a year. The number of immigrants who arrived at the port of New York during the quarter ending January 1, 1900, was 74,892. Of this number four fifths declared their destination to be the states composing the North Atlantic division, of which the state of New York received the largest number. Of these forty-two per cent intended to settle in New York state, nineteen per cent in Pennsylvania, six per cent in New Jersey, six per cent in Massachusetts and three per cent in Connecticut.

THE QUEEN AND CRESCENT

Route makes low rates to Charleston, S. C., for the great meeting of the National Educational Association July 7th-13th. Write W. C. Rinearson, G.P.A., Cincinnati, for particulars.

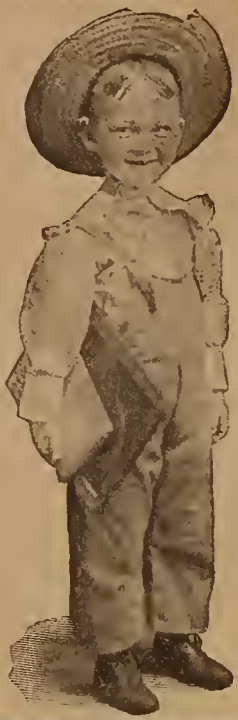

The NATIONAL EDUCATIONAL ASSOCIATION

MEETS THIS YEAR AT CHARLESTON, SOUTH CAROLINA, JULY 7-13

The famous old city will extend its broadest hospitality. The railroads announce low rates. This convention by the seaside is going to be the greatest meeting ever held by the N. E. A. One fare for round trip via Cincinnati and the

Queen and Crescent

Route (plus \$2.00 membership). Stop-over privileges. Choice of routes and the best service that is to be found anywhere.

Write for free illustrated literature concerning Charleston and the way to get there.

W. C. RINEARSON, G. P. A. CINCINNATI, OHIO

Agents Wanted

For the greatest seller published this season, "OUR PHILIPPINE WONDERLAND." Illustrated with hundreds of extra fine, large-size half-tones, with big folding maps, and its 105,000 words of leading matter are as intensely interesting as a novel. REVEALS A NEW WORLD to American readers. Price marvelously low. Send and see for yourself what canvassers say of their surprising success. This is not a war book, but something ten times more interesting and strictly up to date. The unqualified satisfaction it gives subscribers is a rare help in selling it. Agents of either sex, city or country, are reaping a golden harvest, and so can you. For full particulars address the sole publishers, THE CROWELL & KIRKPATRICK CO., Springfield, Ohio

ARE YOU A TOP

wasting pluck and energy in one place—never advancing? We have prepared thousands of young men and women who have studied "between times" to secure enviable positions through our thorough course of

Education by Mail

In Electrical, Mechanical, Steam, Mining and Civil Engineering; Metallurgy, Art, Architecture, Practical Newspaper Work, English Branches, Stenography, Machine Design and Mechanical Drawing. Low price; easy terms. Mention subjects interested in when writing to



THE UNITED CORRESPONDENCE SCHOOLS 154 5th Ave., New York, for catalogue 72.

WE HAVE HUNDREDS OF MEN AND WOMEN MAKING \$25.00 A WEEK EASY

BRADFORD'S AUTOMATIC WASHER

Does complete washing, from fine laces to heavy quilts, in 15 to 30 minutes, without rubbing. Put the clothes in, machine does the rest. Cheaper, cleaner, better than old-style back-breaking washboards and machines. Positively the best selling, most legitimate article on the market. Mr. Hallinan, of N. Y., sold three dozen first week. Mr. Bobb, of Ind., made \$12 in one day. Miss Stevens, of Tenn., \$138 a month. Everybody wants one when they see it work. Many making \$50 a week. Why not you? Write 4-day for how to get an Agent's Sample Free. We start you in business. No scheme, fraud or fake methods. Address BRADFORD & CO., B 40, CINCINNATI, OHIO.

Advertisement for bicycles with prices: \$11.75 Buys a Bicycle Complete, Unguaranteed. \$16.50 Buys an Up-to-Date Model, Fully Guarded. \$22.50 Buys a Full Racing Model, Shop-worn Bicycles from \$10 up. 24 Hand Wheels from \$5.00 up. We want Agents Everywhere. Get 64 page catalogues of bicycle parts and repairs FREE. Write for catalogue and see how you can get a BICYCLE FREE by helping us advertise. Address, Dept. A-3, VICTOR MANUFACTURING CO., 161-167 PLYMOUTH PL., CHICAGO, ILL.

Stringing Bubbles

Boys and Girls Join our Club Get a watch guaranteed for one year. Show the game. It sells itself. In a couple of hours premiums are won. No money required. Send two cents for sample and all information. BOYS' AND GIRLS' JUVENILE CLUB, 10 East 14th Street, New York.

"HAVE A CARRIAGE, SIR?" We Make Them and Sell Direct to You at Less Than Wholesale Prices. Full line of Buggies, Carriages, Canopy Top and Extension Top Surreys, Open Stick Seat Surreys, Phaetons, Traps, Driving Wagons, Concordes, Spring Wagons and all kinds of single and double harness. Every article guaranteed. Shipped anywhere subject to buyer's approval. KALAMAZOO CARRIAGE & HARNESS CO., Box 86, KALAMAZOO, MICH. If not satisfactory return at our expense. We save you \$25 to \$75, according to the job. Get our free illustrated catalogue before buying.

FREE! SEND NO MONEY TO LADIES, BOYS AND GIRLS We send this elegant solid gold or sterling silver plated Bracelet, beautifully engraved, with a dainty little lock and key, also 3 extra gold or silver Friendship Hearts, for selling only 5 sets of our latest style 14-karat gold filled Ladies' Dress or Beauty Pins at 25c. a set. Each pin is set with an exquisite large jewel or will send this gold shell latest style set ring for selling 5 sets. Our rings are set with an exquisite Ruby or Emerald stone, and they are hard to tell from a \$65.00 ring. Send us your name and address only, no money, and we mail you the Pins post-paid. After you sell them among your friends and neighbors, send us the money, and we will send you your choice of the above presents, or many others which you will find in our Large Premium Catalogue of Watches, Jewelry, Tea and Dinner Sets, etc., free with each lot of Pins. You will find these Pins the fastest seller you ever handled. Every stylish lady and girl in the land will buy several sets at sight. We sell over a million each month. This is an honest offer by a strictly reliable house. We take back all you cannot sell, and pay postage on goods and premiums. Don't fail to take advantage of the grandest offer ever made! Write to-day; don't put it off! This firm is well known for its honest goods and valuable premiums. ST. LOUIS PREMIUM CO., Dept. A 28, St. Louis, Mo.

CUT THIS OUT THE ILLUSTRATED BEE TEN WEEKS TRIAL SUBSCRIPTION 15c A Western Illustrated Weekly News Magazine. Interesting pictures of every-day happenings, prominent men and women of the day. Illustrated stories and magazine articles, fashion plates from live models. Oriental pictures from Frank Carpenter's camera, etc., etc. Cut this out and enclose 15 cents to THE ILLUSTRATED BEE, 1706 Farnam Street, Omaha, Neb. TRIAL SUBSCRIPTION COUPON

WANT A WATCH? You can secure a valuable watch absolutely free. Send us your name and address and we will send you by return mail your endless-chain ticket and ten tickets which you are to sell to your friends for 15 cents each, remit the \$1.50 to us, with the names and addresses to whom you sold, and we will send them a supply of tickets like those sent you. When your chain is completed (usually 2 to 3 weeks) we will send a watch of your own selection FREE. Watches guaranteed worth \$15. No lottery. Square dealing guaranteed. Address BOYLSTON & BENT, Rochester, N. H.

BEST FOR THE BOWELS

If you haven't a regular, healthy movement of the bowels every day, you're sick, or will be. Keep your bowels open, and be well. Force, in the shape of violent physic or pill poison, is dangerous. The smoothest, easiest, most perfect way of keeping the bowels clear and clean is to take



Pleasant, Palatable, Potent, Taste Good, Do Good, Never Sickens, Weakens, or Gripe. 10c, 50c. Write for free sample, and booklet on health. Address Sterling Remedy Company, Chicago, Montreal, New York, 322a

KEEP YOUR BLOOD CLEAN

EARN A BICYCLE!



By selling Baker's Teas, etc. No Money required; just take orders among friends and earn a splendid bicycle for a Lady or Gentleman or Boy or Girl. Hundreds of premiums in Watches, Furniture, Crockery, Cameras, Mackintoshes, etc. Express prepaid. Write to-day. W. G. BAKER (Dept. 87), Springfield, Mass.

\$1,000 SALARY PER YEAR!

Ladies or Gentlemen We have shared the general prosperity of the country, and we now need one or two permanent representatives in each state to look after our interests, manage our agents, and attend to collections. This position involves no canvassing and is a bona fide weekly salaried position, with all expenses paid, to the right party. It is mainly office work conducted at your own home, with an occasional trip out among the agents. No investment required. Also three salaried vacancies in the traveling department. Enclose references and self-addressed stamped envelope to PROVIDENCE CO., 227 Carlton Bldg., CHICAGO.

DEAFNESS

Positively CURED at your home, if you can hear any at all, and all noises removed. Write statement of your case. DR. BEN TOMLIN, 1909 CHOUTEAU AVENUE, DEPARTMENT 12, ST. LOUIS, MISSOURI.

FAT PEOPLE

SUFFER IN HOT WEATHER. Get thin before Summer. The Kirby system of individual treatment will rid you of your fat. Essay on the subject of obesity sent for a stamp. MRS. ELEANOR KIRBY, Trust Society Bldg., N. Y.

FREE: SEND FOR BOOK ON NEW PROCESS

ON CANNING FRUITS AND VEGETABLES. MRS. W. T. PRICE, 1431 Penn. Ave. N., Minneapolis, Minn.

\$2.75 buys a MAPLE AND BEE Baby Carriage \$3.00 Buys a Beauty complete with rubber tire wheels and parrot seat. Full line of Sleeping Couches and Co-Cars. 45 page Catalogue Free. Address Dept. 11 VICTOR MANFG. CO., 161 to 167 Plymouth Place, CHICAGO, ILLINOIS.

NEW BOOKLETS

The Chicago, Milwaukee & St. Paul Railway is issuing a series of booklets regarding points of interest along its lines, and if you are interested in the western country, or contemplating a trip, write GEO. H. HEAFFORD, General Passenger Agent, Chicago, Ill., for the special publication desired, enclosing four cents in stamps for postage for each one.

- No. 1. The Pioneer Limited. No. 2. The Land of Bread and Butter. No. 3. The Fox Lake Country. No. 4. Fishing in the Great North Woods. No. 5. The Lake Superior Country. No. 6. Cape Nome Gold Diggings. No. 8. Summer Days in the Lake Country. No. 9. Summer Homes, 1900. No. 11. The Game of Skat. No. 12. Milwaukee—The Convention City. No. 13. A Farm in the Timber Country. No. 14. Stock Raising in the Sunshine State. No. 15. Hunting and Fishing.

TO THE AMERICAN SUMMERLAND

"The Overland Limited," VIA UNION PACIFIC ONLY THREE NIGHTS BETWEEN CHICAGO AND CALIFORNIA

"The Overland Limited" runs every day in the year and makes many hours quicker time between Missouri River and San Francisco than any other line.

Finely equipped with Double Drawing-Room Palace Sleepers, Buffet Smoking and Library Cars, with Barber-Shop and Pleasant Reading-Rooms. Dining-Cars, Meals a-la-carte. Pintsch Light, Steam Heat. For tickets, advertising matter, and full information, call on or address A. G. SHEARMAN, Gen. Agt. Pass. Dept. U. P. R. Co. Room 36, Carew Bldg., Cincinnati, Ohio.

Do You Suffer With PILES

Send us your name and address, and let us mail you our Booklet—"FACTS," about MERTANNO the only specific for the non-surgical treatment of PILES. Our Guarantee: We will refund the price paid for this remedy in any case of Piles if it fails to relieve or cure. MERTANNO PHARMACAL CO., 422 Scott Street, Covington, Ky., U. S. A.

CONSTIPATION POSITIVELY CURED!

SEND \$1.00 for one month's treatment. Express prepaid. Address DR. N. N. MORTON, SPECIALIST, 1909 CHOUTEAU AVENUE, DEPARTMENT 7, ST. LOUIS, MO.

OPIUM and Liquor Habit cured in 10 to 20 days. No pay till cured. Write DR. J. L. STEPHENS CO., Dept. A 8, Lebanon, Ohio.





WHAT I LIVE FOR

BY GEORGE LINNEUS BANKS

I live for those who love me, Whose hearts are kind and true, For the heaven that smiles above me, And awaits my spirit, too; For the human ties that bind me, For the task by God assigned me, For the bright hopes left behind me, And the good that I can do.

I live to learn their story Who've suffered for my sake, To emulate their glory, And to follow in their wake; Bards, patriots, martyrs, sages, The noble of all ages, Whose deeds crowd history's pages, And Time's great volume make.

I live to hold communion With all that is divine, To feel there is a union Twixt Nature's heart and mine; To profit by affliction, Reap truths from fields of fiction, Grow wiser from conviction, And fulfill each grand design.

I live to hail that season, By gifted minds foretold, When men shall rule by reason, And not alone by gold; When man to man united, And every wrong thing righted, The whole world shall be lighted As Eden was of old.

I live for those who love me, For those who know me true, For the heaven that smiles above me, And awaits my spirit, too; For the cause that lacks assistance, For the wrong that needs resistance, For the future in the distance, And the good that I can do.

LINCOLN'S INNER LIFE

LINCOLN'S moral nature will be misunderstood and wrongly valued by all who are hypnotized by the letter and forget the spirit, strain at gnats and swallow camels, and are habitually busy with the beams in their neighbor's eyes. The typical Pharisee, unable to praise the real Lincoln, has treated him after the manner of a funeral eulogy. The true Lincoln was not a prophet crying in the wilderness a message of which he had no doubt and which he alone had heard. He was a pilgrim whose progress to glory was marked by every vicissitude. Much of his life he stood and waited for light, doing in the meantime only the little things which his hand found to do. Even when he was chosen pilot he did not pretend to know all the currents and rocks, or to foresee all the eddies of the storm. He waited for his inspiration from day to day, and believed that if he acted justly to-day to-morrow could be trusted to move toward righteousness.

How bitterly he longed for light, how he even wept for it, when so many about him thought the great questions of right and wrong were easy! Political problems could not to his mind take the neat simplicity with which they were seen, for instance, from various points of view, by Wendell Phillips, by Stanton, by Cameron, by McClellan. His was the task of remembering that there was truth in every position, value in every method, even Cameron's, and of doing justice, as far as the ability was his, to all alike. In its best sense he constantly applied the rule, judge not. He was forced to give decisions, but he never did until they were inevitable, and he never judged in the sense of loftily passing moral sentences on people whose beliefs seemed to him mistaken. One of his dominating and shining qualities was the greatest of the virtues. Charity in every one of its beautiful meanings pervaded him; not only in the moral sense of all-embracing love, but in the intellectual sense of comprehending sympathy was charity his guiding light. It was as much a part of his brain as of his heart, and as truly in thought as in feeling is it the greatest of the virtues. He had that humility which turns the world into a place of constant spiritual growth. His spirit was as teachable as that of a little child.

The inner life of a man like this must grow. It is a mistake to think Lincoln was one man on the prairie and another in the White House, or that he became deeply good and serious at any one period; but the moral element in him did put forth new strength

constantly and hold a more majestic place in his total character at sixty than it did at thirty. His development was natural and regular, and the last of life was the best because his nature was so truly sound.—The Chautauquan.

BUSY PEOPLE SELDOM TROUBLED WITH THE BLUES

Work is the best possible antidote to woe. When in trouble of any kind go to work with all your might. Work when feeling "a little out of sorts" is a surer cure than any medicine the doctor can give you. A busy person is not often troubled with the "blues." Busy persons seldom become misanthropes, anarchists or "firebrands" in the community. There is nothing better to keep mischief out of the head than to keep busy at something useful. The secret of success in life is to keep busy, to be persevering, patient and untiring in the pursuit or calling you are following. The busy ones may now and then make mistakes, but it is better to risk these than to be idle and inactive. Keep doing, whether it be at work or seeking recreation. Motion is life, and the busiest are the happiest. Cheerful, active labor is a blessing. Idleness, when long indulged in, promotes grief and often selfishness. Help such sufferers by encouraging them to be up and doing; rouse them to a sense of the duties that await them, and the welfare of others that depend upon them, and you have done more to comfort them permanently than you could by many words. Yet such efforts to be effective should have no touch of harshness or roughness. An old philosopher says, "The firefly only shines when on the wing; so it is with the mind. When once we rest we darken." "What is your secret?" asked a lady of Turner, the distinguished artist. "I have no secret," was the reply, "but hard work." And that is the only secret that will make a really successful man out of a boy, rich or poor. Work cures more ills than all the doctors in the world.—The Advance.

RUSKIN'S BIBLE

The following words of Ruskin will be read with deep interest at this time: "I open my oldest Bible just now, yellow now with age, and flexible, but not unclean, with much use, except that the lower corners of the pages at chapter seven of the First Book of the Kings and chapter eight of Deuteronomy are worn somewhat thin and dark, the learning of these two chapters having caused me much pains. My mother's list of chapters, with which, learned every syllable accurately, she established my soul in life, has just fallen out of it, as follows: 'Exodus 15 and 20; II. Samuel 1, 5, 17 to end; I. King 8; Psalms 23, 32, 90, 91, 103, 112, 119, 139; Proverbs 2, 3, 8, 12; Isaiah 58; Matthew 5, 6, 7; Acts 26; I. Corinthians 13, 15; James 4; Revelation 5, 6. And truly, though I have picked up the elements of a little further knowledge . . . in mathematics, meteorology and the like, in after-life, and owe not a little to the teaching of many people, this maternal installation of my mind in that property of chapters I count very confidently the most precious, and, on the whole, the one essential part of my education. For the chapters became, indeed, strictly conclusive and protective to me in all modes of thought, and the body of divinity they contain acceptable through all fear and doubt; nor through any fear or doubt or fault have I ever lost my loyalty to them, nor betrayed the first command in the one I was made to repeat oftenest, 'Let not mercy and truth forsake thee.'"—Christian World.

A NOVEL CURE FOR INSOMNIA

A novel remedy for insomnia is to try to picture another person asleep. It is claimed that the more clearly the other person's sleep is pictured the stronger becomes the subjective feeling of drowsiness. Give up trying to sleep. Directly you cease to strive for sleep—to wish ardently for it—a strain is taken off the brain, the body will rest, because the mind is no longer preventing it, and sleep will be the happy result. It is the anxiety for sleep and the worrying about its absence, far more than the sleeplessness itself, that causes the feeling of prostration which follows a sleepless night.

Fancy Belt=Buckles



Premiums No. 382 and No. 447

THE accompanying illustration represents two of the latest fancy belt-buckles which are now very fashionable. This style was selected for its neatness. The engraving is exact size, but cannot do justice to the beauty of the buckles. They are tasty, of good quality, and will give satisfaction.

ROSE GOLD—No. 382 is a gold-plated buckle with the new rose-gold effect. It is very rich.

We Will Send No. 382, and the Farm and Fireside One Year, for . . . . . \$1.00

(When this offer is accepted the club-raiser may have either the regular cash commission or the name may be counted in a club)

No. 382 given as a reward for a club of SIX yearly subscriptions to the Farm and Fireside.

FRENCH GRAY—No. 447 is silver-plated, and is finished in the tasty French gray style. It is very neat.

We Will Send No. 447, and the Farm and Fireside One Year, for . . . . . 75c.

(When this offer is accepted the club-raiser may have either the regular cash commission or the name may be counted in a club)

No. 447 given as a reward for a club of FOUR yearly subscriptions to the Farm and Fireside.

Be sure to order by the numbers, remembering that the buckles are alike, except that No. 382 is gold-plated and No. 447 is silver-plated.

Address FARM AND FIRESIDE, Springfield, Ohio

Six Silver-plated Teaspoons.....

Given for a club of FOUR

These teaspoons can be used in cooking, eating and medicines the same as solid silver. They will not turn brassy, corrode or rust.

Premium No. 60

GUARANTEE.....

We absolutely guarantee these spoons to be exactly as described and to give entire satisfaction or money refunded.....

Postage paid by us



Pure Coin-silver Plating

The base of these spoons is solid nickel-silver, which is the best white metal known for the base of silver-plated ware, because it is so hard and so white that it will never change color and will wear a lifetime. On this base is plated the standard amount of pure coin-silver.

ANY INITIAL LETTER Each spoon is engraved free of charge with an initial letter in Old English. Only one letter on a spoon.

We will send a set (six) of these teaspoons, and the Farm and Fireside one year, for 75 Cents (When this offer is accepted the club-raiser may have either the regular cash commission or the name may be counted in a club)

A set of Teaspoons given free for a club of FOUR yearly subscriptions

Address FARM AND FIRESIDE, Springfield, Ohio

Farmers' Own Knife

A thoroughly practical knife for heavy work. Blades hand-forged from the very best steel. Brass-lined, finely finished. No sharp corners to wear holes in the pocket. Genuine H. & B. goods, well known all over the United States as being hand-forged and high-class. Also a little the highest-priced goods made—that is because they are worth more. This knife usually sells in the stores for not less than \$1.25.



Given for a club of Six Yearly Subscriptions to the Farm and Fireside

We Will Send This Knife, and the Farm and Fireside One Year, for \$1.25

(When this offer is accepted the club-raiser may have either the regular cash commission or the name may be counted in a club)

Given as a reward for a club of SIX yearly subscriptions to the Farm and Fireside. Postage paid by us. Order by Premium No. 273.

Address FARM AND FIRESIDE, Springfield, Ohio





THE MAN WITH THE WHITWASH-BRUSH

Upon a board stretched from two chairs he stands Beside his pail and gazes all around, With streaks of white crisscrossed upon his face, And on his back a spattered old blue blouse! Who put those spots upon the antique rug, Who daubed the parlor chairs with chunks of lime And dripped tobacco-juice upon the floor? Who loosely swung his sopping brush around, And spattered all the frames upon the walls? Not he—no, no!—because he gave his word He'd do the job and never spill a drop. —Chicago Times-Herald.

A GENUINE YANKEE

THE New England small boy generally shows business capabilities at a tender age, if he is ever going to have them. I have heard of a certain small Boston boy who got into the habit of teasing his mother for pennies, until at last she said to him, "Now, Willie, I don't like to give you pennies; if you want money you should go to work and earn it."

The boy remained thoughtful for some time. Then, within a few days, the mother perceived that Willie had plenty of pennies. She wondered a bit where he got them, but did not question him. But one summer day she noticed that some sort of a hullabaloo was going on in the back yard. Looking out, she saw Willie surrounded by a mob of boys, who were yelling with delight. She went down into the yard to see what was going on, and as she passed out she saw stuck up on the back wall of the house this notice, quite neatly "printed" out with a pencil:

WILLIE JONES WILL EAT

1 small green worm for..... 1 cent  
1 large green worm for..... 2 cents  
1 small fuzzy worm for..... 3 cents  
1 large fuzzy worm for..... 5 cents  
1 small green toad for..... 25 cents

Willie was apparently doing a thriving business. His mother interrupted it—at any rate in her own back yard. I don't suppose that she had any assurance that he wasn't still carrying it on somewhere else.—Boston Transcript.

A GIRL'S ESSAY ON BOYS

At a recent school examination for girls this composition was handed in by a girl of twelve. "The boy is not an animal, yet they can be heard to a considerable distance. When a boy hollers he opens his big mouth like frogs, but girls hold their tongue til they are spoken to, and then they answer respectable and tell just how it was. A boy thinks himself clever because he can wade where the water is deep. When the boy grows up he is called a husband, and then he stops wading and stays out nights, but the grown-up girl is a widow and keeps house."—New York Ledger Monthly.

TOO LOVELY!

"Dear me, what charming little birds! They are perfectly exquisite!" said the young lady from London.

"They are not birds, my dear," replied her country cousin; "they are hutterflies!"

"Oh, you don't say so! Then these are the dear little creatures that fly from flower to flower and gather the sweet yellow hutter that we use. They are too lovely for anything!"

VERNAL FOOLISHNESS

"Good-morning, president."

"President of what?"

"Why, of the Crocus club."

"I don't belong to any Crocus club."

"You don't? Well, you've got on the yellowest tan shoes I've seen yet."—Indianapolis Journal.

BRIGHT BITS

There is some wonder that Spring is pictured with her arms full of flowers, instead of carrying empty corn and tomato cans.—Atchison Globe.

After a girl has taken as many as six lessons on the piano she begins to pronounce Beethoven and Wagner in a way to jar her elders.—Atchison Globe.

O'Flaherty—"Is your son working now, Pat?" Pat—"Shure, an' he's got a job in a powder-mill, with good prosp'ets uv gitthin' a rise."—Norristown Herald.

Tramp—"Please, mum, I haven't a friend or relative in the world."

Housekeeper—"Well, I'm glad there's no one to worry over you in case you get hurt. Here, Spot!"

A perl from the smart set stood at the gates of paradise.

"Wouldst thou enter here?" asked the warden.

"No, no, no; not here!" exclaimed the peri, with a shudder. "Please direct me to the porte cochere."

This incident may serve somewhat to explain the difficulty rich persons are said to experience entering the kingdom of heaven.—Detroit Journal.

RIGHT-HANDEDNESS

"Here's a scientist," she said, looking up from the paper, "who asserts that the reason people are right-handed is that the motor speech function controls the right side of the body, and consequently right-handedness grows with speech."

"Is that so?" he returned, deeply interested. "It is indeed strange, then, that many women can use their left hands at all, is it not?"—Chicago Post.

THE SPRING POET'S INSPIRATION



1.—Poet—"Let me see, what rhymes with 'lamb'? Now, some might say that's easy—



2.—"but it don't strike me that way.



3.—"Indeed, I—



4.—"Oh, yes; 'ram' is the word; a good vigorous one, too! Ought to have thought of that before." —Exchange.

The Peerless Pictures

ON HEAVY ART-PAPER 20 BY 25 INCHES IN SIZE

Any THREE of the Pictures Listed Below Given as a Reward for Sending Two Yearly Subscriptions (new or renewal) to the Farm and Fireside.

ANY ONE OF THE PICTURES LISTED BELOW, AND THE FARM AND FIRESIDE ONE YEAR, FOR 35 CENTS. . . . .



No. 796 THE HORSE FAIR Size 18 by 25 inches

SIZE The Peerless series of pictures, including the margins, are 20 by 25 inches in size. Without the margins they are about 16 by 20 inches, varying somewhat according to the subject.

STYLE These pictures are reproduced in the very latest and most tasty style. They are not cheap chromos or attempts at color reproduction, which usually bear no resemblance to the originals.

Grand Reproductions of Famous Paintings

- IMMACULATE CONCEPTION . . . Painted by Murillo . . . Prem. No. 784
- PHARAOH'S HORSES . . . Painted by Herring . . . Prem. No. 785
- QUEEN OF FLOWERS . . . Painted by Lefler . . . Prem. No. 786
- AFTER WORK . . . Painted by Holmes . . . Prem. No. 787
- CHRIST BEFORE PILATE . . . Painted by Munkacsy . . . Prem. No. 788
- DEFIANCE, or STAG AT BAY . . . Painted by Landseer . . . Prem. No. 789
- KISS ME (Child and Dogs) . . . Painted by Holmes . . . Prem. No. 790
- THE LITTLE SHEPHERDESS . . . Painted by Koller . . . Prem. No. 791
- PORTRAIT OF WASHINGTON . . . Painted by Stuart . . . Prem. No. 792
- THE FINDING OF MOSES . . . Painted by Schopin . . . Prem. No. 793
- CAN'T YOU TALK . . . Painted by Holmes . . . Prem. No. 794
- WATERFALL BY MOONLIGHT . . . Painted by Rieger . . . Prem. No. 795
- THE HORSE FAIR . . . Painted by Bonheur . . . Prem. No. 796



No. 785 PHARAOH'S HORSES Size 20 by 25 inches

This is the first time that faithful copies of the world's greatest works of art have been reproduced so they could be offered on such popular terms.

We Will Send the Farm and Fireside One Year and any Two of these Pictures for 50 Cents

(When this offer is accepted the club-raiser may have either the regular cash commission or the name may be counted in a club)

FREE Any THREE of these Pictures, Your Choice, Given as a Premium for TWO Yearly Subscriptions to the Farm and Fireside.

The pictures will be sent by mail, securely packed and postage paid. Entire satisfaction guaranteed. A beautiful twelve-page circular giving illustrations and descriptions of the paintings sent FREE on request. Write to-day.

Postage paid by us

Address FARM AND FIRESIDE, Springfield, Ohio



# FREE A NEW CURE FOR KIDNEY AND BLADDER DISEASES, RHEUMATISM, ETC.

Disorders of the Kidneys and Bladder cause Bright's Disease, Rheumatism, Gravel, Pain in the Back, Bladder Disorders, difficult or too frequent passing water, Dropsy, etc. For these diseases a Positive Specific Cure is found in a new botanical discovery, the wonderful Kava-Kava Shrub, called by botanists the *Piper methysticum*, from the Ganges River, East India. It has the extraordinary record of 1,200 hospital cures in 30 days. It acts directly on the Kidneys, and cures by draining out of the Blood the poisonous Uric Acid, Lithates, etc., which cause the disease.

Rev. John H. Watson testifies in the *New York World* that it has saved him from the edge of the grave when dying of Kidney disease and terrible suffering when passing water. Mr. Calvin G. Bliss, North Brookfield, Mass., testifies to his cure of long-standing Rheumatism. Mr. Jos. Whitten, of Wolfboro, N. H., at the age of eighty-five writes of his cure of Dropsy and swelling of the feet, Kidney disorder and Urinary difficulty. Many ladies, including Mrs. C. C. Fowler, Locktown, N. J., and Mrs. Sarah Tharp, Montclair, Ind., also testify to its wonderful curative power in Kidney and allied disorders peculiar to womanhood.

That you may judge of the value of this Great Discovery for yourself, we will send you one Large Case by mail free, only asking that when cured yourself you will recommend it to others. It is a Sure Specific and cannot fail. Address The Church Kidney Cure Company, 471 Fourth Ave., New York.

## 1200 Dollars Given Away

A	C	D
E	E	E
H	L	M
N	O	P
S	S	S
W	Y	Y

**CAN YOU** arrange the 18 letters at the left into three names denoting **THREE WELL-KNOWN ADMIRALS** of the U. S. NAVY during the **SPANISH WAR**? If you can make out these names you may share in the **DISTRIBUTION OF 1200 DOLLARS WHICH WE ARE GIVING AWAY** for doing a little work for us. This you can do in less than one hour of your time. This and other liberal offers are made in the **1000** of the very best Boston Story Magazines into every house in the United States and Canada. **WE DO NOT WANT ONE CENT OF YOUR MONEY.** When you have made out your answer, write it plainly on a postal card and send it to us, and you will hear from us promptly **BY RETURN MAIL.** It may take considerable study to get the three correct names, but **STICK TO IT AND TRY AND GET YOUR SHARE OF THE 1200 DOLLARS. A COPY OF A CELEBRATED DOLLAR BOSTON MAGAZINE WILL BE SENT FREE** to every one answering this advertisement. Send your answer immediately. Address: **THE RIGLEY PUBLISHING COMPANY, 88 and 90 Purchase Street, BOSTON, MASS.**

## FAT

**How to Reduce it**  
Mrs. L. Lanier, Martin, Tenn., writes: "I reduced my weight 2 1/2 lbs. in 15 days without any unpleasant effects whatever." Purely vegetable, and harmless as water. Any one can make it at home at little expense. No starving. No sickness. We will mail a box of it and full particulars in a plain sealed package for 4 cents for postage, etc. **HALL CHEMICAL CO., Dept. B, St. Louis, Mo.**

## \$5.00 A DAY EASY FOR ALL WILLING TO WORK

Gold, Silver, Nickel, Metal Plating. At home or traveling, taking orders, using and selling Prof. Gray's Machines, Plating Machines, Jewellery, Tableware, Bicycles and all metal goods. No experience. Heavy plate. Modern methods. We do plating, manufacture outfits, all sizes. Guaranteed. Only outfits complete, all tools, lathes, materials, etc., ready for work. We teach you the art, furnish secrets and formulas **FREE.** Write to-day. Pamphlet, samples, etc., **FREE.** **D. GRAY & CO., Plating Works, CINCINNATI, O.**

## \$83.33 MONTHLY SALARY

**PAYABLE WEEKLY** with EXPENSES  
Men or Women to represent us in their own state. Your duties to take charge of solicitors and attend to collections. No investment required. Send stamp for application blank. **CO-OPERATIVE CO., 395 Star Bldg., Chicago, Ill.**

## RUPTURE

Sure Cure at home; at a small cost. No operation. No pain, danger or detention from work. No return of Rupture or further use for Trusses. A complete, radical cure to all (old or young). Easy to use; thousands cured; book free (sealed). **DR. W. S. RICE, Box F, Adams, N. Y.**

## ECZEMA

Facial Blemishes, Tetter, Salt Rheum, Barber's Itch, Scald Head, Ring Worm, Itching Piles, Sore Eyelids, and all Skin diseases promptly cured by Spencer's Ointment. Sent to any address on receipt of 25c. **A. O. PILSON, Pharmacist, 1327 W. Baltimore St., Baltimore, Md.**

## THE ELECTRICITY

from the batteries will turn a needle through your table or hand. Cures Rheumatism, Liver and Kidney Disease, Weak and Lame Back, etc. For advertising purposes we will give one Belt Free to one person in each locality. Address **E. J. SNEAD & CO., Dept. No. 65, VINELAND, NEW JERSEY.**

## LADIES TO DO PLAIN SEWING

at home, \$1.50 per day, four months' work guaranteed. Send stamped addressed envelope for full particulars. **R. W. HUTTON & CO., Dept. 3, Philadelphia, Pa.**

## \$60 PER MONTH AND EXPENSES

active man to travel; permanent position; experience unnecessary. (LARK & CO., 234 South 4th St., Philadelphia, Pa.)

## GOLDMETER

In pocket case for hunting Silver, also Rods and Needles. Circular 2 cents. **B. G. STAUFFER, Dept. F. F., Harrisburg, Pa.**

## PLAYS

Dialogues, Speakers, Amusement Books. Catalog free. **T. S. DENISON, Publisher, Dept. 5, CHICAGO.**

## We Pay \$18 A WEEK AND EXPENSES

to men with rigs to introduce our Poultry Compound. Send stamp. **Javelle Mfg. Co., Dept. 58, Parsons, Kan.**

## WANTED AGENTS

In every county to sell "Family Memorials;" good profits and steady work. Address **Campbell & Co., 158 Plum St., Elgin, Ill.**

## RUPTURE CURED

when you work. You pay \$4 when cured. No cure, no pay. **ALEX. SPEIRS, Box 37, WESTBROOK, MAINE.**

## "THE NICKEL SPEAKER" 50 cts. A YEAR

5 cts. A COPY. 50 new pieces each month, for all grades. **Toledo, Iowa.**

## Coe's Eczema Cure \$1

at druggists. 25c. size of us. **COE CHEM. CO., Cleveland, O.**

## BED-WETTING CURED.

Sample FREE. **Dr. F. E. May, Bloomington, Ill.**

# HOUSEHOLD

[CONTINUED FROM PAGE 11]

## A SACRIFICE OF SERVICE

THEY sacrifice by serving small churches." These words appeared lately in a report concerning educated ministers, and none deny the truth; yet the sacrifice is often a great boon to those thirsting for a knowledge of the word of God. See a picture!

Forty years ago there was a simple little meeting-house, a wooden building painted white, with green blinds. Now it is well furnished, enlarged, has a pipe-organ and electric-lights; while then the musical instrument was a melodion, and kerosene-lamps gave the light by night.

The church had the ministry of a very gifted man, who had been for many years a New York pastor, but whose physician advised a quieter life for a time. This pastor, like Apollos of old, was mighty in the Scriptures, and not only was himself instructed, but he had a marvelous gift of teaching. He saw in his people a devotional spirit, but a lack of the food furnished by a closer acquaintance with the word of God.

He gathered about him a large week-night Bible-class, not only of men and women, but of many young people. Finances were low, and when it was summer the trustees decided not to hire a sexton until fires for winter were needed. One and another swept and dusted when it had to be done for the Sunday service, and the prayer-meeting was held down in the porch or lobby. The key was at a house near by, and whoever got to the church first would unlock it, and light a lamp if one could be found with sufficient oil. This would not do for the preparation for the Bible-class. That was held in a dingy, long room over the porch. There was a table, with seats down three sides. It was necessary to have clean lights and things ready for real class-work. This teacher did not lecture, but asked questions all around, and many references had to be looked up and read. It must be light, and decently clean. For a few times the pastor went himself and opened the church, filled the lamps and rung the bell, for no one went to any meeting there unless a bell was rung. He finally said if there was not interest enough to have those things attended to he would not keep up the class. There was a little girl who went regularly to the class who was fairly fascinated with the study of the book of the Acts. It was her first idea of a thorough study of the Bible. She had been to Sunday-school and learned her verses, she loved her day-school work, but she had never known what a delightful study the Bible was. She resolved that the lamps should be filled, and the house open and ready if she could possibly manage it, and not have any one know that she did it. She was not ashamed of the service, but was afraid she would not be allowed to do it.

The place was always ready, and homely and plain as was the room the spirit of God was there. To those already interested the teacher and pastor opened the word, and he awakened in others an interest in the poetry, the beauties and truths of the Bible. He was himself finely educated, yet he did not need to go to any other text-books to find inspiration for teaching. He did not talk about the uses of great books as helps to Christianity, but of the uses of one great book, the Bible, as a help to Christian living.

Now, after forty years have passed, that church is still noted for its fine Bible-scholars and the interest always kept up in the study. Much is due the pastor, who really sacrificed a great deal in his four years' living in the village. Perhaps in the other world to which he has long since gone no greater harvest may greet him than that from the sowing of the word in that Bible-class.

The little girl who kept the light said years afterward that she had never been happier in any service than she was as lamp-girl, just from love of God's word.

In every village church there are bright minds, and many hungering and thirsting for more knowledge of the Bible. In many such churches there is little money, and it may be necessary to do without the service of a janitor for part of the year at least. If there is a good leader, keep the class up. Remember the little wooden church nestled down in a pretty little valley, and how helpful was one young girl. And let no minister feel that his life and work are wasted in such a village church.

Though they sacrifice by serving small churches, the time may come that it will be "a sacrifice of thanksgiving."

MARY JOSSLYN SMITH.

## MARRIED AT THE AGE OF 123

### STILL A YOUNG AND ACTIVE BUSINESS MAN. THE SECRET OF A LONG, STRONG LIFE

When Dr. Smith, of New York City, gave his age to the officiating clergyman as one hundred and twenty-three years it nearly barred the ceremony. It wasn't only that he claimed to be one hundred and twenty-three, but he did not look over fifty. It seemed as if the man was crazy. But he wasn't. He was simply an example of a man who had brought the science of living to the highest perfection known in modern times.

No man wants to last out a hundred years, to exist practically dead to use and service. But to live a century in active participation



"The wonderful one-hoss shay, That was built in such a logical way It ran for a hundred years and a day."

in life's duties, in hearty enjoyment of its pleasures—"tis a consummation devoutly to be wished for."

The question is, "Is this long and happy life within the reach of the majority of men, and how may it be secured?"

### FEW PEOPLE DIE A NATURAL DEATH

It is a startling statement to make, and yet it is supported by high evidence. Professor R. A. Proctor, in an article in the "Cosmopolitan Magazine," quotes an eminent physician as follows:

"In all the wide experience of long practice I have only known one person die a natural death. A natural death is when death results from the simultaneous decay of all the organs. But men die mostly from the decay of one—heart, lungs, liver, brain, kidneys. This is not a natural death."

When a man dies a natural death he breaks up like "the wonderful one-hoss shay, which was built in such a logical way it ran for a hundred years and a day." Any termination of life other than that general decay is unnatural.

There is no disputing the fact that unnatural living leads to unnatural dying.

Few people realize that these several organs—heart, lungs, liver, brain, kidneys, etc.—are being strengthened or weakened with every mouthful of every meal which is eaten. It is nevertheless a fact that at the meal-table and the lunch-counter the warrant of unnatural death is daily signed. Each organ of the body is dependent on the stomach and its allied organs for its health and vigor.

Because the stomach is the center of supply for the whole body and each organ of that body, and because weakness of the stomach and its allied organs of digestion and nutrition must mean weakness of the organs depending on them for alimentation, it follows as an axiom that

### NO MAN IS STRONGER THAN HIS STOMACH

No better illustration of the relation of diseased heart, lungs, liver, kidneys, etc., to a diseased stomach can be found than is furnished by the cures of these diseased organs by Dr. Pierce's Golden Medical Discovery. This medicine cures diseases of the stomach and the associated organs of digestion and nutrition. But in doing this it acts upon the blood which is made from food, and which must carry with it from the diseased stomach the taint of disease. Blood is made from food. Blood is the life of the whole body and its every organ. But if the food digested is deficient in quantity of nutrition, by reason of the weakness of the digestion, then the blood must be deficient in quality and the whole of the vital powers will be affected. Whatever affects the quality of the food as nutriment affects the quality of the blood produced from food, and whatever affects the quality or quantity of the blood affects each organ of the body which depends on blood for vigor and vitality.

### A SCIENTIFIC PROPOSITION

Diseases of organs seemingly remote from the stomach, which have their origin in a diseased condition of the stomach, are cured

through the stomach. That is the scientific explanation of the cures of heart, liver, lungs, kidneys and other organs by the use of Dr. Pierce's Golden Medical Discovery.

"Your 'Golden Medical Discovery' has performed a wonderful cure," writes Mr. M. H. House, of Charleston, Franklin Co., Ark. "I had the worst case of dyspepsia, the doctors say, that they ever saw. After trying seven doctors and everything I could hear of, with no benefit, I tried Dr. Pierce's Golden Medical Discovery, and now I am cured."

Mr. Edward Jacobs, of Marengo, Crawford Co., Indiana, writes: "After three years of suffering with liver trouble and malaria I gave up all hopes of ever getting stout again, and the last chance was to try your medicine. I had tried all the home doctors and received but little relief. After taking three bottles of Dr. Pierce's Golden Medical Discovery and one vial of his 'Pleasant Pellets' I am stout and hearty. It is due entirely to your wonderful medicines."

"I had been a great sufferer for several years, and my family doctor said I would not be a living man in two years, but, thank God, I am still living," writes Mr. George W. Trustow, of Lipscomb, Augusta Co., Va. "Dr. Pierce's Golden Medical Discovery is what saved my life. I had heart trouble so bad that I could not lie on my left side without a great deal of pain. I was nearly past work when I commenced your medicine, but I can do about as much work now as any man. I cannot say too much for the benefit I have received."

### THE LOGIC OF FACTS

There is no escaping the logic of the cures effected by the use of "Golden Medical Discovery." When a medicine for the stomach and blood cures diseases of heart, lungs, liver, kidneys, etc., it must be because these organs are diseased through the diseased stomach. Dr. Pierce's Golden Medical Discovery cures dyspepsia, stomach "weakness," catarrh of the stomach and other diseases of the stomach and digestive and nutritive systems which prevent the proper nourishment of the body. It increases the activity of the blood-making glands. By promoting the perfect assimilation of the digested food it builds up the body with sound, healthy flesh instead of the flabby fat produced by nauseous cod-liver oil or the modified nastiness of emulsions. Food is the only means Nature uses to supply life and support it. All strength comes from food. In removing the obstructions to the nutrition of the body caused by disease "Golden Medical Discovery" works with Nature and in her own way to establish the body in sound health and strength.

There is no alcohol in "Golden Medical Discovery," and it contains no opium, cocaine or other narcotic.

Sometimes the dealer will offer a substitute for the "Discovery" because of a little more profit paid by such inferior articles. The substitute is a gain to the dealer, but a loss to you. It won't do what the "Discovery" does. If you want the cures "Discovery" works, insist that you will take no substitute.

Persons suffering from diseases in chronic form are invited to consult Dr. Pierce by letter, free. All correspondence strictly private and sacredly confidential. Address **Dr. R. V. Pierce, Buffalo, New York.**

### HOW TO LIVE LONG

The science of living is so thoroughly explained in Dr. Pierce's Common Sense Medical Adviser that "he who runs may read." The man or woman who will study this book and apply its precepts will surely make life richer and better. It is full of practical hints on hygiene and helps against disease. The book, containing 1,008 large pages, is sent free on receipt of stamps to pay expense of mailing only. Send 31 one-cent stamps for mailing the book, bound in strong cloth, or if satisfied to have so valuable a work in paper covers, send 21 stamps only for mailing. Address **Dr. R. V. Pierce, Buffalo, New York.**

### CHARLESTON-BY-SEA

National Educational Association, Charleston, S. C., July 7th-13th. Low rates Queen and Crescent Route and Southern Railway. Write for free books to **W. C. Rinearson, G.P.A., Cincinnati.**

### NOME CITY, ALASKA

Is twenty-four hundred and fifteen miles from Seattle via ocean, thirty-three hundred and eighteen miles overland. Is said to be the richest gold-field discovered up to this time. The first steamer will leave Seattle on or about May 10, 1900. For full particulars, maps, etc., address **Geo. H. Heafford, General Passenger Agent Chicago, Milwaukee & St. Paul Railway, Chicago, Illinois.**



# The Standard American Cook Book

AND THE FARM AND FIRESIDE ONE YEAR, FOR 40 CENTS

This Cook Book contains thousands of the most valuable recipes and desirable formulas by noted experts and over two hundred practical housekeepers. It covers every branch of cookery, with special directions for serving at table; also preserving, pickling, candy-making, etc., and ten more chapters of helps.

### Plain and Fancy Cooking in Great Variety

**A**TENTION is called to the unequalled variety characterizing the recipes in this Cook Book. Practical housekeepers consider this one of the very strongest features of this new work, adapting it to universal use, and suiting every occasion, from a simple and inexpensive home meal to an elaborately prepared entertainment for company.



RUBBING SAUCES THROUGH THE TAMMY

The only Amply Illustrated work on the cuisine within reach of the women of America. Nearly 400 large pages.

### This is the Cook Book You Want

**B**ECAUSE its plan includes the valuable and useful points of other cook books, and IN ADDITION it has inestimable features of its own entirely new. For REGULAR USE it will give you the best of satisfaction as a clear, safe, reliable, economical kitchen guide, with an abundance of good things to choose from. It far surpasses all others.

### Plain Cooking



PASTRY POTATOES

### Fancy Cooking



LAMB CUTLETS

More . . . .  
Than 250 . .  
Explanatory  
Illustrations

**M**AKING clear at a glance important processes in plain and fancy cooking. To show HOW a thing should be done amounts to far more practically than any mere bidding do it. Once accustomed to the pictorial object-teaching methods of this THOROUGH and COMPREHENSIVE work, no lady will be willing to go back to the unsatisfactory directions of other cook books. This Cook Book has a complete index.

This Book Given FREE for a Club of TWO Yearly Subscriptions to the Farm and Fireside.

This Grand Book, and the Farm and Fireside One Year, for

## 40 Cents

(When this offer is accepted the club-raiser may have either the regular cash commission or the name may be counted in a club)

Order by Premium No. 10

## IN HIS STEPS

"WHAT WOULD JESUS DO?"

BY REV. CHARLES M. SHELDON

**T**HE most widely read book of the century. Other books have been sold by the hundreds of thousands and were considered remarkably successful, but this book has been sold by the millions. The story was written by the Rev. Charles M. Sheldon, of Topeka, Kansas, and read by the author, a chapter at a time, to his Sunday-evening congregation in the Central Congregational Church of that city. Having been put in book form its sale has been world-wide, several millions of copies having been sold.

The story has been warmly welcomed by Endeavor societies, temperance organizations, Young Men's Christian Associations, and Christian organizations everywhere, as a great incentive to right living.



**Have You Read It?** If not, you certainly should do so, as it is one of the most remarkable works ever produced. The copy we offer is the regular authorized edition, full and complete, printed on good paper and well bound in substantial paper cover.

We Will Send This Book, and the Farm and Fireside One Year, for . . . . . **40 Cents**

(When this offer is accepted the club-raiser may have either the regular cash commission or the name may be counted in a club)

Given as a reward for a club of TWO yearly subscriptions to the Farm and Fireside. Order by Premium No. 45.

## Helena

The Charming Romance

BY CAPTAIN H. S. IRWIN

**H**ELENA is a strong story entwined about a thrilling life's romance. It promises to be one of the remarkable books of the day. The plot is well conceived and skilfully carried out, and the reader is led from chapter to chapter with growing interest till the culmination is reached at the very end of the book. The strange career of Captain Presley Brannan, his disappearance, the dual life, and the sensational disclosure under startling circumstances, is not fiction, but facts. The author has adhered to truth with all the art of a finished story-writer.

This is one of the most readable as well as most suggestive of recent novels. It is a story of American life, and most effectively illustrates the saying that truth is often stranger than fiction, for many of its most striking incidents and most interesting characters are drawn from real life.

The story had its counterpart in real incidents which occurred in Memphis, Corinth, Louisville and southern Ohio not many years ago. The characters combine to create scenes of Southern life that are true to experience. Made up of cordiality and despicable enmity, subserviency and chivalry, pathos and pleasantry, all in an ingenious manner.

The book contains 278 pages well printed on good paper and attractively bound.

It is published in the regular edition at \$1.25, but we have made up a special edition for the readers of the FARM AND FIRESIDE which we are able to offer at a great bargain.

THIS BOOK GIVEN FREE AS A PREMIUM FOR TWO YEARLY SUBSCRIPTIONS TO THE FARM AND FIRESIDE

We Will Send This Book, and the Farm and Fireside One Year, for Only . . . . . **60 Cents**

(When this offer is accepted the club-raiser may have either the regular cash commission or the name may be counted in a club)

ORDER BY PREMIUM No. 23

Address FARM AND FIRESIDE, Springfield, Ohio

Postage paid by us



# 40 Cent Patterns for 10 Cents

We Will Send Any TWO PATTERNS, and This Paper One Year, for 40 CENTS

(When this offer is accepted the club-raiser may have either the regular cash commission or the name may be counted in a club)

These patterns retail in fashion bazaars and stores for twenty-five to forty cents each, but in order to increase the demand for our paper among strangers, and to make it more valuable than ever to our old friends, we offer them to the lady readers of our paper for the low price of only 10 Cents Each.

Full descriptions and directions—as the number of yards of material required, the number and names of the different pieces in the pattern, how to cut and fit and put the garment together—are sent with each pattern, with a picture of the garment to go by. These patterns are complete in every particular, there being a separate pattern

for every single piece of the dress. All orders filled promptly.

For ladies, give BUST measure in inches. For SKIRT pattern, give WAIST measure in inches. For misses, boys, girls or children, give both BREAST measure in inches and age in years. Order patterns by their numbers.

Satisfaction guaranteed or money refunded. To get BUST and BREAST measure, put the tape-measure ALL of the way around the body, over the dress, close under the arms.

Special price of each pattern 10 cents. Postage one cent EXTRA on skirt, tea-gown and other heavy patterns.

## FREE We will give any THREE of these patterns for FREE TWO yearly subscriptions to Farm and Fireside

Address FARM AND FIRESIDE, Springfield, Ohio



No. 7973.—LADIES' DRAPED WAIST WITH GIRDL. Sizes, 32, 34, 36, 38 and 40 inches bust. 10 cents.



No. 7975.—LADIES' TUCKED SKIRT. Sizes, 22, 24, 26, 28 and 30 inches waist. 11 cents.



No. 7967.—MISSES' WAIST. 10c. Sizes, 12, 14 and 16 years.



No. 7968.—LADIES' TAILOR-MADE BASQUE. 10 cents. Sizes, 32, 34, 36, 38, 40 and 42 inches bust.



No. 7964.—GIRLS' DRESS. 10 cents. Sizes, 4, 6, 8 and 10 years.



No. 7978.—LADIES' TAILOR SHIRT-WAIST. 10 cents. Sizes, 32, 34, 36, 38, 40 and 42 inches bust.



No. 7972.—GIRLS' BLOUSE COSTUME. Sizes, 4, 6, 8, 10 and 12 years. 10 cents.

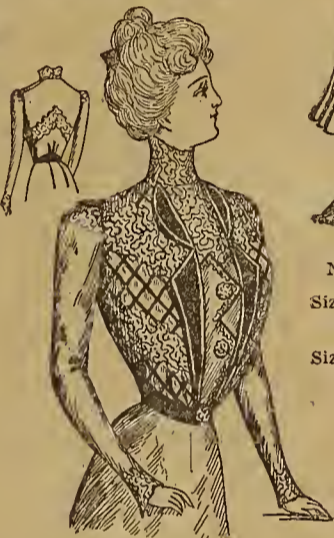

No. 7971.—LADIES' FANCY BODICE. 10 cents. Sizes, 32, 34, 36, 38 and 40 inches bust.



No. 7960.—LADIES' FOUR-PIECE SKIRT. 11 cents. Sizes, 22, 24, 26, 28 and 30 inches waist.



No. 7979.—LADIES' FANCY WAIST. 10 cents. Sizes, 32, 34, 36, 38 and 40 inches bust.



No. 7981.—LADIES' TUCKED WAIST WITH YOKE. 10 cents. Sizes, 31, 34, 36, 38 and 40 inches bust.

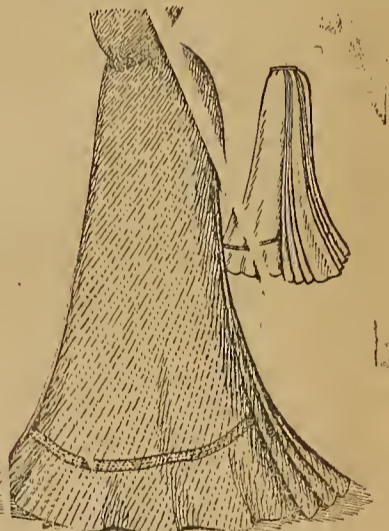

No. 7974.—LADIES' SKIRT WITH CIRCULAR FLOUNCE. 11 cents. Sizes, 22, 24, 26, 28 and 30 inches waist.



No. 7970.—GIRLS' GORED SKIRT WITH GATHERED OR DOUBLE BOX-PLAITED BACK. 10 cents. Sizes, 6, 8, 10 and 12 years.

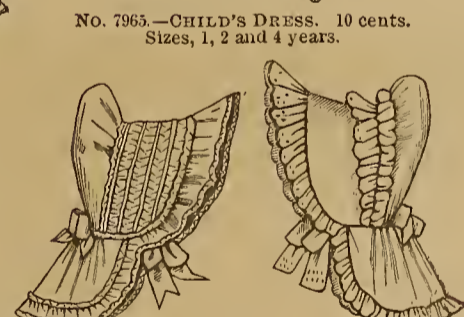

No. 7980.—LADIES', MISSES' AND CHILDREN'S SUNBONNETS. The three patterns for 10 cents.



No. 7966.—LADIES' BOX-PLAIED SHIRT-WAIST. 10 cents. Sizes, 32, 34, 36, 38, 40 and 42 inches bust.

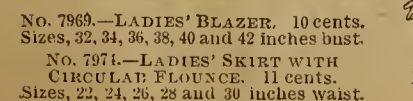

No. 7976.—MISSES' BLAZER. 10 cents. Sizes, 12, 14 and 16 years.



No. 7969.—LADIES' BLAZER. 10 cents. Sizes, 32, 34, 36, 38, 40 and 42 inches bust.



No. 7982.—LADIES' SINGLE-BREADED BASQUE. 10 cents. Sizes, 32, 34, 36, 38, 40 and 42 inches bust.



No. 7960.—LADIES' FOUR-PIECE SKIRT WITH BOX-PLAIED BACK. 11 cents. Sizes, 22, 24, 26, 28 and 30 inches waist.



AMONG THE FOOT-HILLS OF THE ROCKIES  
[CONTINUED FROM FIRST PAGE]

up among these hills the rainfall is much heavier than upon the plains. The summer tempest gathers thick over them; clouds roll in inky blackness, the lightnings cleave the heavens, and torrents pour down, filling the gulches with roaring cascades that carry huge boulders upon their tide; and lo! the sun breaks forth, and no drop of water has fallen without the outer boundaries of the range. Tremendous downpours these Rocky-mountain showers are; cloud-bursts they are called, and such they seem to be. It were as if the clouds let themselves down from the heights and then suddenly opened their flood-gates, pouring forth their watery contents in bucketfuls. In fifteen minutes or less after the fall of the first premonitory drops I have seen the water pour down a hillside to the depth of six inches. As a consequence the rivers and creeks in a few minutes become raging torrents.

I never could quite fathom all the mysteries of mountain ranching; how the ranchmen fix the boundary-lines and keep their herds within them. I see their barbed-wire fences running for miles and miles up and down the glades; see them straggle transversely across the glades from crest to crest of the ridges; lose sight of them as they climb long, steep hills and vanish among the pines or over the summits. Then there are mysterious openings and angles and gateways in the most unheard-of places. By the way, there are many natural barriers that serve as fences, notably the rocky crests of these ridges. I have seen them run for miles with a gentle grassy slope until near the top, when there would be an abrupt outcropping of ledges that no dumb animal on earth could surmount, unless it were the traditional cow that jumped over the moon. But I suppose that by an intricate knowledge of the bovine character, considerable fencing and a pretty constant riding on the range the cattleman keeps his stock where it belongs, and as a general thing lives at peace with all men, including his neighbors.

A happy man I conclude this mountain rancher to be. I see him upon his sure-footed steed flitting here and there among the mazy hills, sun-bathed and breathed upon by light, caressing breezes. Now he descends a steep hillside, leaning far back toward the crupper to preserve his equilibrium, and bracing his feet in the stirrups to avoid slipping ungracefully over the patient animal's head, and crossing a narrow gulch, hidden for a moment as he plunges through a bunch of wild cherry-bushes; then he mounts the opposite steep and reverses his attitude, almost hugging his broncho's neck, to keep from slipping off over the crupper. But how carefully the well-trained steed picks his way up the rocky steep, seldom, if ever, receiving a precautionary signal from his rider. Whenever the ground will permit the horse breaks into an easy lope, the rider holding the bridle-rein high and loose, and swaying gently the hand that holds it as he wishes to turn to the right or to the left; and in such close sympathy is the rider and the ridden that the will of the man acts upon the brute by the slightest and most delicate electrical process. I watch steed and rider until they disappear through the high and sun-lit avenues that wind among the pines upon the hill-top, and almost envy the man his free and wholesome life.

All day the ranchman rides among the silent, sun-lit hills. There is hardly a sound in all the valleys or on the hillsides save the sighing of the wind through the pines, or the still small voices of the birds, the chipmunks and ground-hogs, or perhaps the chatter of the magpies in the clumps of wild plum-trees in the gulches. There is even no lowing of the cattle that graze far and near, for they are content, and lowing, I am inclined to believe, is a sign among the cattle of sorrow or some kind of physical suffering. He has ridden over these self-same hills a hundred, nay, a thousand, times already, yet each day reveals some new and interesting feature, some new and charming view. In the sheltered southern nooks he feels all the warmth of the sun's fervent rays, which descend unobstructed by cloud or vapor; and as he pauses upon some airy point he is fanned by far-faring breezes that blow over the crest of a thousand hills and through a thousand vales, gathering fragrance from the pines and wild mountain herbs. And I can imagine how, as he straightens himself in his saddle to more easily inhale the perfumed ether that is wafted to him, and drink in the beauties of Nature that lie spread out before him in wide panoramic view, a thrill of divine joy passes through his being.

Nor do I think I am far wrong in my conjecture, for I have had ocular and testamentary proof of it. Not long ago a friend

of mine who was about to retire from a lucrative public office bought a nice little fruit-farm quite near town.

"I suppose," I said to him one day, "that when you have thrown aside the robes of office and bid farewell to the world of politics you will retire to this small earthly paradise and spend the rest of your days beneath your own vine and fig-tree?"

He smiled at my flight of rhetoric, and shook his head with an air of indecision.

"Well, if that don't suit, why don't you buy a mountain ranch and retire to the fastnesses?" I continued.

"Oh, I wouldn't do that!" he replied, quite decidedly.

"And why not?" I asked.

"I never would be good for anything else," he returned; and then I knew he was wise unto his own generation. The Colorado mountaineer is like the lotus-eater of Tennyson's poem, once ensconced behind granite barriers he contemplates with loathing a return to the "mad'ning crowds' ignoble strife."

FEMININE DAIRY WISDOM

Now the calf that had the good fortune to be born last fall and live free from flies for six months kicks up its heels and starts well for a long summer's growth. Don't underestimate the intelligence of your calf; it knows a good deal more than you did at its age. Treat it as you would treat your baby, gently, kindly, and you should have no trouble with kicking, hooking, or the other nasty little tricks you know so well. It should cost you about seven cents a day to feed your cow—twenty-five dollars a year. If you practise good principles of farming her manure should offset the cost of shelter and labor. Now, if you don't get enough to pay for her feed, don't keep her. Take the world over, there are more good cows and sensible men than there are poor cows and fools. The trouble is to get the wise men and good cows together. When we do this fewer men will be complaining that "dairyin' don't pay." Sour milk may not be relished quite so much by calves at first, but it is a good thing to raise calves on if they cannot have it sweet invariably. A change of food from sweet to sour occasionally is detrimental to growth, and often begins scours. Use great care in turning to pasture. Give a good feeding of hay in the morning, and do not leave them out all day. A profitable ration because balanced is coarse bran, two hundred pounds, gluten-feed, one hundred and twenty-five pounds, and cotton-seed meal, one hundred pounds. Give a cow seven to ten pounds a day, according to her size. Most poor rations are weak in protein, the nitrogenous element of food. Supply this in the ration and you will not need to buy expensive nitrogen fertilizers, for it has a fertilizer as well as a food value.—Dorothy Tucker, in Farm Journal.

SUBSTITUTES FOR HAY

Many farmers are asking for some spring crop to supply the deficiency in hay for next winter. Some seem to have the idea that there is something new to be had that will take the place of hay. Those who read this paper know that it advocates the old reliable staple crops and urges limited trial of substitutes for them. Therefore, in this instance an extra area of corn and oats would have been, probably, the best thing that could be provided, cutting the oats a little on the green side and feeding unthreshed along with the corn fodder. But it is a little too late for the oats. Next to these, and some think ahead of them, we might place sorghum, Kafir-corn, etc. These crops produce a large quantity of forage, but are not so readily cured and kept as the others. Probably more farmers are growing them now than ever before. The soy-bean is coming into prominence as a forage crop to bridge over a clover failure, and an experiment with it might be profitable. Much can be done to help out next winter's hay shortage by careful pasturage, providing some crop to ease the demands upon the late grass and allowing a good fall growth. Probably rape and sorghum will be the most effective for this purpose. Much can be done, also, by a proper saving of the corn fodder and studying how to feed it. There is a vast waste of corn fodder in this country, not only in the field, but in the feed-lot, and a short hay supply may teach us a valuable lesson in its use.—National Stockman and Farmer.

N. E. A.

Reduced rates via Queen and Crescent Route from all points north to Charleston, S. C., account the great National Educational Association meeting in July. Free books. W. C. Rinearson, G.P.A., Cincinnati.

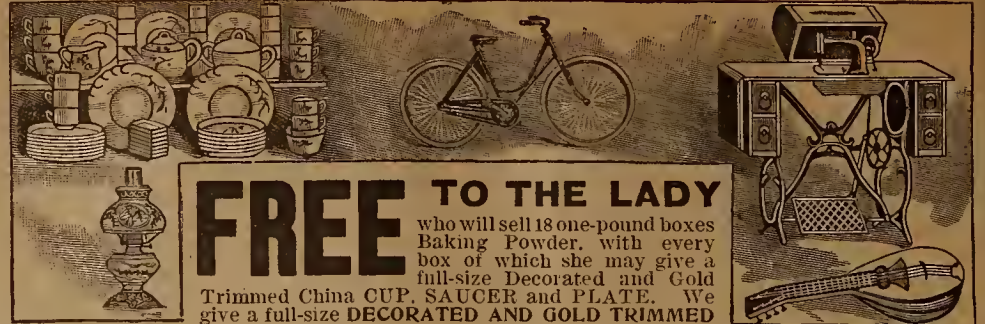

**FREE TO THE LADY**  
who will sell 18 one-pound boxes Baking Powder, with every box of which she may give a full-size Decorated and Gold Trimmed China CUP, SAUCER and PLATE. We give a full-size DECORATED AND GOLD TRIMMED

**Tea Set, a Guitar or a Solid Silver Ladies' Watch**  
NO MONEY REQUIRED until you have delivered the goods.

**WE PAY THE FREIGHT** and ship your Premiums with the goods. Induce your friends to work for us and we pay you well.

WRITE FOR OTHER PLANS TO-DAY  
We refer to the Farmers' and Traders' National Bank as to our reliability. **J. CHAS. T. WALTHALL & CO., Cincinnati, Ohio**

**Young Buckeye Walking Cultivator**

Something New in the Line of Walking Cultivators, Yet the Most Practical Walker Ever Built  
Has all the advantages of a parallel movement, yet without any joints or connections to wear out. Front ends of the gangs operate automatically on ROLLER BEARINGS on axle, allowing them to take a direct line of draft, which always keeps the gangs parallel and the shovels square with the row. The gangs are suspended from a chain and rod at the center of them to a flat spring, which makes them VERY EASY TO OPERATE. Made both pin and spring shovel. We make a full line of riding and walking cultivators.  
If in the market for a walking cultivator, do not fail to investigate the merits of this implement.

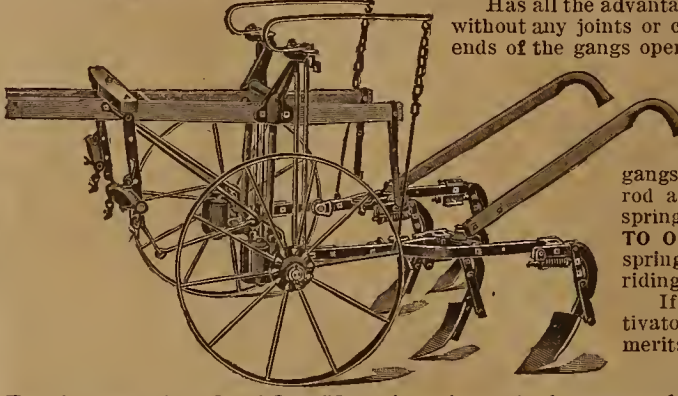

SEND FOR CATALOGUE

**P. P. MAST & CO., No. 17 Canal Street, SPRINGFIELD, OHIO**

**FREE TRIAL** YEARS **PIANO \$155.00 UP**

Money back with interest if not satisfied with your bargain. Write today for our latest catalogue. It is free. It shows you the latest and most up-to-date Organs and Pianos on the market. It tells you all about our patent combination actions and orchestral attachments which imitate a great variety of stringed instruments. Something new and novel that never fails to please. A discount of \$10.00 on every Organ and \$20.00 on every Piano if you get our catalogue now. We sell for cash or on easy payments. No money in advance required. From factory to home. No agents. No middlemen's profits. Write today.

**BETHOVEN PIANO & ORGAN CO.**  
Box 628 Washington, N.J.



**Watch and Chain FOR ONE DAY'S WORK.**

This Cut is 1-2 Actual Size of Watch and Chain.

We send this Nickel-Plated Watch, also a Chain and Charm to Boys and Girls for selling 1 1/2 dozen packages of BLUINE at 10c. each. Send your full address by return mail and we will forward the Blaine, postpaid, and a large Premium List.  
No money required. We send the Blaine at our own risk. You go among your neighbors and sell it. Send us the money that you get for it and we send you the Watch, Chain and Charm, prepaid.  
This is an American Watch, Nickel-Plated Case, Open Face, Heavy Bevelled Crystal. It is Guaranteed to keep Accurate Time, and with Proper Care should last ten years.

**BLUINE CO., Box 392 CONCORD JUNCTION, MASS.**  
The Old Reliable firm who sell honest goods and give Valuable Premiums.



**Deal with the Makers**

When you buy a carriage, buggy or harness. Choose from the biggest stock and fullest assortment, and pay only the cost of making, with but one moderate profit added. Our plan of selling direct from the factory insures satisfaction—your money back if you're dissatisfied with your purchase—and enables you to **save the dealer's profit.**

Our complete illustrated catalogue, showing many styles of high grade vehicles, harness, robes, blankets and horse equipments, with detailed descriptions of each, mailed free. Write for it and learn how cheaply you can buy when the jobber's and dealer's profits are cut off.

**THE COLUMBUS CARRIAGE & HARNESS CO., P. O. Box 772, Columbus, O.**



**1900 YOU CAN EASILY EARN**

bicycles, sewing machines, house furnishings, ladies' or gentlemen's watches, cameras, mandolins, guitars, violins, silverware, dinner sets, guns, and your choice of a hundred other articles, all guaranteed. Simply sell a few boxes of our unexcelled toilet soaps and any of them are yours. Send no money. We trust you. Girls and boys do as well as older people. Write at once for full information. We mail handsome illustrated catalog free. Address **Great Northern Soap Works, 92 Lake St., Oak Park, Ill.**



**Rife Hydraulic Engine**

PUMPS WATER AUTOMATICALLY BY WATER POWER. Place this engine two feet or more below your water supply and it will deliver a constant stream of water 30 feet high for every foot of fall.  
WITHOUT STOPPING.  
WITHOUT ATTENTION.

**POWER SPECIALTY CO., 126 Liberty Street, NEW YORK.**



**PAINT**  
**ADAMANT MILK PAINT**  
using skimmed milk instead of oil in mixing; 12 years' test, and outwears lead and oil at one seventh the cost.

**BARN PAINT**  
IN RICH BROWN, RED AND YELLOW  
thoroughly ground and mixed in the best oils and pigments. The best in the market for the price.

MAIL US A POSTAL FOR PRICE-LIST. This advertisement will not appear again this spring.

**NEW YORK ROOF PAINT CO.,**  
World Building, New York City.

**SAVE YOUR CASH**

You need fence. The ready made kinds cost from 60 to 75c. a rod. We tell you how to make the best fence on earth for **20 to 35 Cents per Rod.** Over 100 Styles, and from 50 to 70 rods per day. Send for our free Catalogue.

**KITSELMAN BROTHERS,**  
Box 278 Rldgeville, Indiana, U. S. A.





# FARM & RESIDE

LIBRARY RECEIVED  
MAY 01 1900  
Department of Agriculture

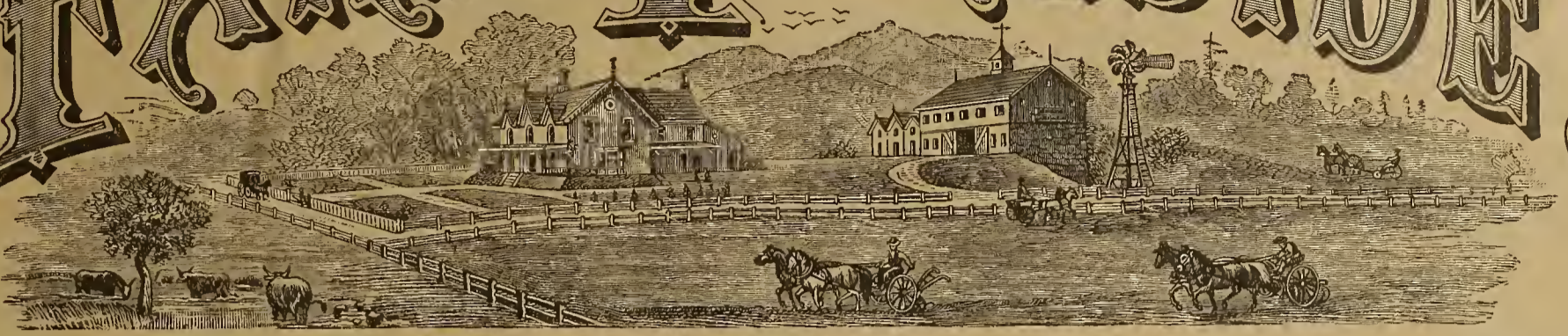

Vol. XXIII. No. 17

EASTERN EDITION

JUNE 1, 1900

Entered at the Post-office at Springfield, Ohio, as second-class mail matter

TERMS (50 CENTS A YEAR 24 NUMBERS)

## VARIETY IN HORTICULTURE IN THE GOLDEN STATE

**A**T THE past December meeting of the Columbus Horticultural Society Professor Thomas F. Hunt read an interesting paper on the horticulture of Northern California, from which the following extracts are taken:

"One of the most impressive and pleasing features of California is its great variety of vegetable forms. Almost every form of plant-life, except strictly tropical plants, find a congenial home within its borders. Nearly all the cultivated fruits of the world, except those of the tropics, can be found growing in a single county of the state. To see the vegetable forms of Russia and the vegetable forms of Egypt growing side by side is a startling and pleasing sight.

"The oldest and best-developed valleys of Northern California are the Santa Rosa on the north and the Santa Clara on the south, each seventy-five to one hundred miles long and perhaps averaging ten miles in width. Passing up the narrow valley of Santa Rosa to Ukiah one passes through a dairy district, a poultry district, a fruit district—largely peaches and grapes—and a wine district, where at Asti is to be seen the largest wine tank or cistern in the world (500,000 gallons).

"The orange district of Northern California is at Oroville and Palermo, about the latitude of Philadelphia, and perhaps five hundred miles north of Los Angeles. From Palermo alone last year were shipped one hundred and thirty car-loads of oranges. The total area of this colony, which was surveyed in 1888, is seven thousand acres; thirty-five hundred acres have been sold, three thousand acres have been planted, and about one thousand acres in bearing oranges. Besides oranges are raised also peaches, olives, English walnuts and lemons.

"At Marysville and Yuba City peach orchards of one hundred and sixty acres are common. While at Woodland we visited the Yolo orchard, which contained five hundred and twenty acres of bearing trees, principally peaches, and will soon have six hundred and forty acres of bearing trees. While the principal crop in these orchards is peaches, yet prunes, apricots, nectarines, almonds and raisin-grapes are grown commercially.

"Fresno, on the southern border of Northern California, is one of the great centers of the raisin-grape industry. Here it is aptly said they raise enough raisins to command the attention



DATE-PALM IN DOORYARD

tion of the commerce of the world. They raise three fourths of the raisins of the United States, and yet the total area devoted to raisin-grapes in this locality is less than two townships.

"At or near Salinas is an area—one of a few limited areas compared to the whole state—where the sugar-beet thrives so excellently that Claus Spreckels feels justified in building the largest beet-sugar factory in the world. This factory is six hundred feet long, one hundred feet wide and one hundred and twenty-five feet high. It has a capacity of three thousand to four thousand tons of sugar-beets a day, and has all its machinery in duplicate, so that when one piece gets out of order another stands ready instantly to take its place. This factory cost \$2,500,000.

"San Jose and its environs deserve special mention. Here is a territory twenty miles square set solidly almost to orchards, principally prunes. It is said to be the largest prune territory in the world. Drive in any direction within this territory and you will be flanked on every side with thrifty and perfectly cultivated orchards. There are handsome country homes, fine graded schools, rural mail delivery and sprinkled country roads. It is claimed \$8 a month a mile is spent for sprinkling roads during the dry season. This is done primarily, I understand, to keep the dust off the fruit, but it goes without saying that whatever the purpose it is evidence of abundant prosperity. A man with fifty acres of orchard appears to have an assured and satisfactory income.

"This is the most prosperous and cultivated rural country community I have ever seen, and yet it is on the edge of the wilderness, and seems to me will remain so for many years to come."



A GOLDEN GATE PARK VIEW



## FARM AND FIRESIDE

PUBLISHED BY

THE CROWELL &amp; KIRKPATRICK CO.

OFFICES:

147 Nassau Street,  
New York CitySpringfield,  
Ohio204 Dearborn Street,  
Chicago, Illinois

Subscriptions and all business letters may be addressed to "FARM AND FIRESIDE," at either one of the above-mentioned offices; letters for the Editor should be marked EDITOR.

## TERMS OF SUBSCRIPTION

One Year - (24 Numbers) - 50 Cents  
Six Months - (12 Numbers) - 30 Cents

The above rates include the payment of postage by us. All subscriptions commence with the issue on press when order is received.

Subscribers receive this paper twice a month, which is twice as often as most other farm and family journals are issued.

Payment, when sent by mail, should be made in Express or Post-office Money-orders, Bank Checks or Drafts. WHEN NEITHER OF THESE CAN BE PROCURED, send the money in a registered letter. All postmasters are required to register letters whenever requested to do so. DO NOT SEND CHECKS ON BANKS IN SMALL TOWNS.

Silver, when sent through the mail, should be carefully wrapped in cloth or strong paper, so as not to wear a hole through the envelop and get lost.

Postage-stamps will be received in payment for subscriptions in sums less than one dollar, if for every 25 cents in stamps you add one-cent stamp extra, because we must sell postage-stamps at a loss.

The date on the "yellow label" shows the time to which each subscriber has paid. Thus: Jun 1900 means that the subscription is paid up to June, 1900; Jul 1900, to July, 1900, and so on.

When money is received, the date will be changed within four weeks, which will answer for a receipt.

When renewing your subscription, do not fail to say it is a renewal. If all our subscribers will do this, a great deal of trouble will be avoided. Also give your name and initials just as now on the yellow address label; don't change it to some other member of the family; if the paper is now coming in your wife's name, sign her name, just as it is on the label, to your letter of renewal. Always name your post-office.

## The Advertisers in This Paper

We believe that all the advertisements in this paper are from reliable firms or business men, and do not intentionally or knowingly insert advertisements from any but reliable parties; if subscribers find any of them to be otherwise we should be glad to know it. Always mention this paper when answering advertisements, as advertisers often have different things advertised in several papers.



IN THE May number of the "Crop Reporter," published by the authority of the Secretary of Agriculture, is an interesting article on "Agriculture in India," reading in part as follows:

"The famine which is now prevailing in British India, and exciting sympathy and generous aid from many remote parts of the world, is likely to prove the most calamitous event in the agricultural history of the closing year of the nineteenth century. Over five millions of people, many of them denizens of vast and populous districts, difficult of prompt and timely relief, are now dependent for the means of sustaining life from day to day upon organized public and private benefaction; and the animal power, upon which Indian agriculture so largely depends, is being weakened steadily by the death of thousands of cattle from thirst and starvation. In a calamity like this, where a great part of a nation of approximately 300,000,000 people is involved in varying degrees of privation and want, only the imagination can conceive the scene of destitution so faintly outlined by numerical lists of actually helpless sufferers.

"Agriculture in India, the chief occupation of the people, is probably carried on under more discouraging circumstances than in any other country of the world. Although favored by great fertility of soil and conditions of temperature propitious to a remarkable variety of exuberance of plant-life, a peculiar feature of Indian agriculture is that the germination and growth of all unirrigated vegetation depends upon the characteristic seasonal rains, commonly known in India as the monsoon rains. In the spring, as the surface of this vast peninsula becomes heated by the tropical sun, the "wet monsoon"—steady southwest wind, amounting often to a gale—sets inland from across the Indian ocean and the Arabian sea, and prevails late into autumn. It may be noted, incidentally, that another monsoon, somewhat opposite in many

of its characteristics, prevails during the other half of the year. Usually beginning about the middle of May, these southwest winds, diverted into various currents by mountains and other agencies, precipitate upon the land heavy rainfalls of rain. As would naturally be supposed in an empire of 1,500,000 square miles—in fact, almost equal in extent to all Europe less Russia—the distribution of even a monsoonal rainfall is never equable over the entire country.

"Total failure of the monsoon current over expanses of thousands of square miles is not uncommon, and famine is the inevitable result in the territory affected. In some localities, in fact, rain is scarcely relied upon at all to supply a sufficiency of soil moisture; in others the regular recurrence of the monsoon at almost identical periods of the year is regarded as a safe assurance of never-failing crops. In the northwest of the empire—that is, in the southwest Punjab and in Sind—an extensive system of irrigation canals is maintained as essential to the successful practice of agriculture; opposite, in the eastern part of the empire—that is, in Burma, Assam and Bengal—the monsoon is almost as certain as the change of seasons, and there total crop failures from drought are seldom experienced. Any part of the rest of India, however, excepting that narrow strip which lies between the Western Ghats mountains and the Arabian sea, and extends from Bombay to the southern extremity of the peninsula, is liable to drought from unequal distribution or local failures of the monsoon. In many localities of the endangered territory, especially in the central provinces and immediately north of them, wells, tanks, reservoirs and canals are maintained on an extensive scale, both at public and private expense, to store water against the certain hour of need.

"Extending from eight degrees to thirty-five degrees north latitude, a range corresponding to those latitudes that lie between the southern extremity of the Isthmus of Panama and the southern boundary of Tennessee, the vast plains of India are favored with a climatic range adapted to all the products of tropic and temperate zones. Fortunately, too, for the sometimes urgent domestic needs of the people, two and even three crops of some food products, though not always from the same soil, may be produced in the course of a single year. Wheat is cultivated in all the provinces of India, but by far the larger quantity is produced in the northern half. Cotton is likewise produced throughout the entire country, but nearly two thirds of the crop comes from the southern half of the dependency. Corn is the staple food of a considerable part of the inhabitants of the tracts affected by famine this year. Rice is extensively cultivated, and is produced in Burma, Madras and the eastern part of Bengal far in excess of the aggregate consumptive needs of those provinces. Millet is a favorite product of cultivation, and is said to contribute to the staple food of a larger number of the inhabitants of India than does any other cereal. Flax is raised in exportable quantities; from eighty to ninety per cent of the entire crop is produced in the territory comprising the northwest provinces, the central provinces and Bengal. Coffee, tea, tobacco and sugar are produced; the fibrous plants, hemp and jute; and, in short, an extraordinary variety of products adaptable to the uses of commerce as well as to the domestic needs of the people."

ON THE day of the arrival of the Boer commission in New York Chairman Fischer is reported to have said, "If we cannot induce the government to espouse our cause, we shall try to arouse the people, and they will compel the government to recognize us in that way." Any envoy to the United States who begins the work of his mission with such a threat can hardly have hopes of becoming a successful diplomatist. History has a parallel to this scheme of compelling our govern-

ment to comply with the demands of foreigners by a resort to popular agitation.

In 1793 Charles Edmond Genet, minister from France, arrived in this country on a special mission. Everywhere he went he was most cordially welcomed by the people, whose sympathies were almost unanimously with their ally in the Revolutionary war. Genet endeavored to get President Washington to abandon his attitude of neutrality and join France in her war against England, but in vain. Encouraged, however, by formal receptions and popular demonstrations of approval of France's cause, he appealed to the people, and sought through them to compel Washington to do his will. He maintained that this country was in duty bound to aid France against England, in return for the necessary aid France had given in establishing the independence of the United States. He denounced the Washington administration for lack of sympathy with a young "sister" republic. But all in vain. Washington promptly demanded and obtained Genet's recall as minister; and the American people, much as they sympathized with France, resented his impertinent efforts to dictate the foreign policy of our government.

"The Boer commissioners," says the Boston "Herald," "come here for the purpose of persuading the American people, acting through our national government, to interfere in their behalf, and thus bring to a close the war in South Africa, certainly without loss to them of independence, and possibly without territorial and other losses. These commissioners have visited in person or by proxy practically all of the great capitals of Europe, and have made their petition in vain. If they could have succeeded in moving the German Emperor, the Czar of Russia or the French republic to act in their behalf they would not have considered it necessary to make this long trip across the Atlantic to present their petition to us in person.

"It is a noteworthy illustration of the manner in which we are regarded in Europe that those in Paris, Berlin, Vienna, Rome and St. Petersburg who are strongly favorable to the Boers, and distinctly hostile to the English, are constantly insisting that the Americans are the proper people to interfere in this matter, and that by abstaining we are not doing our duty to humanity, or playing the role in the world which destiny intended us to take up and carry forward as the avowed champion of oppressed nationalities. If these statements were sincere they might be considered decidedly flattering, but unfortunately on the basis named they are open to grave doubts. The Germans, French, Italians and Russians are well aware that intervention in the manner they propose means war with England, and would in their cases imply a loss of trade and a serious risk if they attempted to put their wishes into action. Like the monkey in the fable, they would much prefer to have their purposes served by the cat's-paw of another, and they look upon our people, who, they believe, with some reason, are given to spontaneous and bumpitious action, as being well calculated to afford them this fun and profit without the least expense to themselves.

"Undoubtedly the Boer commissioners have been advised to come to the United States by these shrewd European diplomatists, and have been told that on this side of the Atlantic there is a great nation which has shown on more than one occasion that it is willing to be guided rather by its heart than its head, and to rush into adventures without taking the least trouble to forecast the probable outcome of such enterprises. In reality, based upon the grounds on which European diplomacy rests, there is no nation which would have so much to lose by a proceeding of this kind as our own.

"We have said that we would not permit European powers to interfere in the affairs of the western continent.

But we cannot course with the hare and hunt with the hound, and any attempt at interference by us in the affairs of South Africa would be simply an invitation to the continental powers of Europe to interfere whenever they pleased in the affairs of Central and South America. Nothing would please the shrewd diplomatists of continental Europe better than to have England and the United States involved in a war which not only represented the ignoring on our part of the Monroe doctrine, but which, by greatly weakening the two great Anglo-Saxon powers, would throw open the western hemisphere to the eager exploitation of the governments of continental Europe."

COMPLYING with a House resolution requesting information concerning the manufacture of oleomargarine Secretary Gage sent to the Speaker a statement showing the quantities and kinds of ingredients used in that product in the United States for the fiscal year ended June 1, 1900. One of the tables reads as follows:

MATERIALS	POUNDS	PER CT.
Neutral lard.....	31,297,251	34.27
Oleo-oil.....	24,491,769	26.82
Cotton-seed oil.....	4,357,514	4.77
Sesame.....	486,310	.53
Coloring matter.....	148,970	.16
Sugar.....	110,164	.12
Glycerin.....	8,963	.01
Stearin.....	5,890	.007
Glucose.....	2,550	.003
Milk.....	14,200,576	15.55
Salt.....	6,773,670	7.42
Butter-oil.....	4,342,904	4.76
Butter.....	1,568,319	1.72
Cream.....	3,527,410	3.86
Totals.....	91,322,260	100.00

Over one third of the oleo product as shown by the internal revenue figures is "neutral." Neutral is a harmless word, meaning neither one thing nor the other. In the oleo business it is an elastic term used to hide the real character of the stuff that is the chief ingredient of the product. Sometimes it is one thing, sometimes another. For practical purposes, however, "neutral lard" may be defined as "devised" hog-grease; that is, any kind of cheap hog-fat, no matter how clean or unclean, whether from sound or diseased animals, put through a refining process and turned into stuff resembling deodorized vaseline.

Commenting on the vigorous opposition in the House to the passage of the resolution which brought forth the information given above, "Chicago Produce" says:

"The reasons for a desire to hide the character and quantity of ingredients of oleomargarine are twofold:

"First, the oleomargarine manufacturers have been misrepresenting the facts to all producers of these ingredients. The cattle people are told that their product is principally used in shape of beef-fat; the hog people are led to believe that the majority of oleomargarine is lard, while the cotton-seed oil makers are advised that the most important ingredient of oleomargarine is this vegetable oil. Hence, each of these interests has been brought to Congress to oppose the passage of the Groat bill.

"Second, it has been discovered that oleomargarine is not the wholesome, nutritious and digestible article of food that it is claimed to be. The New York authorities found from nine to eleven per cent of paraffin in several lots they analyzed. Paraffin is an absolutely indigestible petroleum product. The editor of 'Chicago Dairy Produce' has ascertained that a large quantity of stearin is used in the cheaper goods where a great deal of cotton-seed oil is employed; in order to give the mixture the body that is necessary. Stearin is the hardest fat in the beef after all the soft oils have been squeezed out. It is the stuff tallow candles are made of, and its melting temperature is one hundred and fifty-two degrees, which is sixty-four degrees above the temperature of the stomach. It is insoluble in either alcohol or ether unless they are brought up to the boiling-point. It is generally used, as above stated, for the production of tallow candles."





ABOUT RURAL AFFAIRS

**The Belgians**

The Belgian hares have gotten me into a pickle. My reference to them, in issue of May 1st, seems to have struck a responsive chord in the hearts of a large number of readers, and I have received and am receiving in every mail numerous letters asking for addresses of breeders and for prices on stock which I may have to sell, etc. It is quite a task for me to reply to all these inquiries, and I wish to say that I am not a professional breeder of these interesting animals, but grow them only for the purpose of supplying my table with an excellent kind of meat, and cheaply, too. I do not make a business of selling breeding stock; besides, I notice that almost all rural papers nowadays not only speak occasionally of these rabbits, but also carry a good supply of the advertisements of breeders. I see it stated that Belgian-hare skins (which are tough enough for whiplashes, and not tender like wild-rabbit skins) are now being used for imitation sealskin. If that is the case, and the skins can be sold even for a moderate price, it would add that much to the value of the animal, and to the profits to be derived from their propagation. I do not know how true the statement is, but hope that it is founded on fact.

\*\*\*

**Shipping-boxes**

My indignation has often been aroused by the excessive rates which I had to pay to the express companies for forwarding packages containing eggs for hatching, rabbits or other live animals, etc. For long distances these rates are often prohibitive. A few weeks ago I shipped a pair of rabbits to Tennessee, and although the animals were not full-grown, weighing scarcely eight pounds together, and the box was made very light, I had to guarantee the payment of over \$3 express charges. I shall bless the day when Uncle Sam will take a hand in the business, and give us a cheap parcel post, thus freeing us from the murderous grip of these transpor-

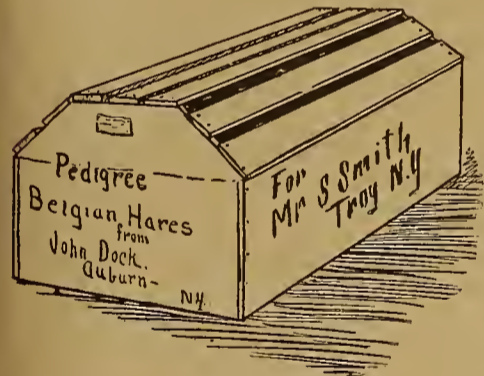

SHIPPING-BOX

tation monopolies. Sooner or later this will happen. In the meantime I shall avoid long-distance shipments so far as I can, and when I must ship, reduce size of package as much as can be done, first by shipping younger and therefore smaller animals, and then by the selection of lightest packages. Just at the present time a great deal of shipping Belgians is being done. In the comparatively few instances that I have been shipping rabbits, pigeons, etc., I have made use of a light box, the upper corners of which had been cut away and the cover replaced by light slats. The illustration makes this plain. To have the boxes especially light I prefer to make them of white cedar or linden, of course well seasoned. Common store-boxes, however, may be fitted up in this way, and come handy for shipping small animals.

\*\*\*

**The Privy Vault**

With the beginning of warmer weather the privy vault will again need close attention. My friend Dr. Goff, of Pennsylvania, writes in an Eastern paper as follows: "The privy is on many farms and in village houses an abomination of abominations. The privy pit should everywhere be abolished. It poisons air and water. It is the cause of most of the typhoid fever on farms. The proper place for animal waste is in the

soil as soon as it can be gotten there. Our privy is near the barn, hidden behind some evergreens. It is entered by ascending several steps. This leaves an open space below, into which we throw loose earth. The contents are shoveled into a box, which is dragged to the manure-pit, the contents emptied and well covered with straw and other litter, so that the cattle cannot come in contact with it. Some would doubtless prefer to handle the ashes and chicken droppings separately, to be applied to the hill. For me that would mean more work and extra expense. I prefer to let them grow clover, and turning that under get better results than by hill-manuring." Dr. Goff's way is good and safe. I have a tight box on a wheelbarrow which is used as a receiver, and partially filled with dry soil, muck, road dust or sifted coal ashes, and emptied at least once a week during the summer, and once in two or four weeks during the winter. The liquids should not be allowed to soak into the ground, especially if the privy is not far from the well. But it is not easy always to spread this stuff evenly over a field, unless dry absorbents have been used very freely. The best way to dispose of it is the one given by Dr. Goff. Horse manure is best for the purpose. The mixture will soon lose its offensiveness and become easily manageable. It will make an all the better and more evenly balanced manure if some superphosphate and some kainit are added to it.

\*\*\*

**The Flea-beetle**

A lady reader, Mrs. F. S., of Washington, asks what to do for the little black flea-beetle which eats up or punctures her tomato and potato tops, turnip-leaves, etc. There are two things which these little jumping-jacks do not like; namely, tobacco-dust and Bordeaux mixture. The application of either will usually drive them, or at least the great majority of them, away from the treated plants. If the beetles are left to work on the plants they will surely injure the plants' vitality, and make them especially subject to the early blight. This is one of the reasons why we always spray the potato-vines with Bordeaux mixture (of course, with some arsenical poison added). Egg-plants are extremely susceptible to the attacks of flea-beetles, and blight afterward, and I never fail to keep the plants well covered with the Bordeaux mixture almost the entire season.

\*\*\*

**Buying Eggs for Hatching**

This spring I heard of the "Blue Langshan," and being anxious to see what the breed looks like, sent to Connecticut for a setting (fifteen eggs), paying therefor \$3, besides \$1 express charges. I put five of my Black Langshan eggs with them and set them under two hens. Out of the lot I got three blacks and two blues; but one of the latter was weak at its birth, and has since died. So I got one little chick for my \$4 and my trouble. What seems to be wrong with these high-grade eggs sent out by our fancy breeders? Simply this, that the fanciers keep their flocks in confinement, in idleness, and by far too well fed. This treatment makes weak offsprings. The eggs will not hatch, being entirely unfertile, or the chick in them will not have vitality enough to come to full development. As long as fancy fowls are kept in small inclosures and coddled and pampered such "eggs for hatching" will hatch poorly and give little satisfaction. A person might better spend \$10 or more for a good trio of the desired breed than pay at the rate of \$2 or more for "eggs for hatching." You can establish a flock much more quickly and more cheaply in this way. Yet I have frequently sent to other states for Black Langshan eggs, buying them in fifty or one hundred lots, and had good success in hatching and rearing the chicks. But the parties who furnished me these eggs are people who keep only one breed, and manage this

as farmers keep theirs; namely, give their fowls practically unlimited range and only ordinarily good care. The hen that has to "scratch for a living" usually lays eggs that are just right for hatching, and her chicks will be strong and healthy. In a general way I keep my Langshans on the same principal that I keep Belgian hares; namely, for practical purposes, not for fancy points. Neighbors often come to me for "eggs for hatching." In fact, I often have to buy the eggs wanted for table use, as my own are all wanted for setting. But it seems to me rather unreasonable in people to expect me to trade eggs with them, egg for egg, as many do. While in New Jersey I used to sell my Langshan eggs to neighbors at fifty cents a setting of thirteen, and at this rate I have often bought them in large quantities from some of my old neighbors, who keep their flocks pure and up to the standard. In short, these eggs are worth more than common scrub eggs; but when I ask more than market price some people think I am trying to get the better of them. This is also frequently the case with people who want to buy a good rooster. I have to pay \$3 to \$5 for a reasonably good bird. Some people expect to buy one of a neighbor at six or seven cents a pound. Altogether I believe that both the fancy breeders and the people who wish to improve their farm stock have yet much to learn about "eggs for hatching" and such things.

T. GREINER.

**SALIENT FARM NOTES**

**The Garden**

Just at this time the garden is very apt to be neglected, owing to the multitude of jobs that are crowding upon us. It will pay us well to put a man in the field and give the garden a thorough going over. It will not pay to give the job to a boy, or to a man that detests such work. I have done that and absolutely thrown away the amount paid for the work—if work it could be termed. By far the best plan is to tackle the job ourselves and do thorough work, then it will not need doing over again in three or four days. What to do with a strawberry-bed when the last of the fruit is gathered is a puzzle to many. If the bed is a large one I would give it a good harrowing the first thing, and clear off all the leaves and mulch, then with a plow run between the rows—which should be not less than four feet apart—and turn two furrows together, leaving a strip where the rows are twelve to sixteen inches wide, then harrow them down by first going straight along the rows, then diagonally across them. This will leave the patch in good condition, the surface mellow and fine, and sufficient plants to make runners enough to form a good stand before winter. I have seen beds worked over in this manner, and not touched again during the season, make matted rows that were nearly perfect, and yield an immense crop the following year. In most cases, however, it will be necessary to go over them with the hoe once or twice, to cut out the large weeds that are sure to spring up here and there. If the patch is a small one it should be mowed, raked clean and spaded up. Almost any sort of a workman can do this.

\*\*\*

**Bugs and Worms**

All of the bug, worm and beetle enemies of the farmer are now at work with a full head of steam on, and we will have to battle early and late if we desire to overcome them. Poisons and kerosene are the best weapons for us to employ. For potato-beetles I know of nothing better than London purple or Paris green. Both of these articles are adulterated to such an extent that a correct formula is impossible. I place a small quantity in a cup and moisten it with cold water exactly as flour is moistened for wall-paper paste. When moistened in this way it readily mixes with water instead of floating on the surface, as it does when thrown dry into a pail. I test it by putting one teaspoonful in a bucketful of water and spraying a row of plants. If the larvae are killed I use it that strength. If they are not destroyed within twenty-four hours I double the quantity used. The best apparatus for spraying potato-

vines, or in fact any plant or bush not higher than one's head, is the little tin sprayers to be obtained at almost any hardware or seed store. They blow the material on the plants in a fine spray, and a small quantity of the liquid will cover a great deal of surface, while one can spray a large patch in a day with very little labor.

\*\*\*

For the currant and gooseberry worm, and also for all worms that eat the leaves of roses and other shrubs, I use hellebore, about one ounce to three gallons of water, spraying it on same as Paris green is sprayed on potato-plants. Hellebore is poisonous, but not so dangerous as Paris green or London purple. For spraying apple-trees for the codling-moth and other like pests I use the new arsenical poison discovered by Professor Kedzie, of Michigan. It is composed of white arsenic and sal-soda, and is far more effective than Paris green or London purple, while costing much less. It is made as follows: Take one pound of white arsenic and four pounds of lump sal-soda. Put both in an old cooking-vessel, pour over them one gallon of hot water, and place on the stove and boil about fifteen minutes. This will dissolve the two and form a clear liquid. Cool it a little, pour into a jug, and label "poison," and hang it high out of the reach of any one likely to sample it. Take a little less than a pint of this stuff for each forty-gallon barrel of water, and stir well. For each barrel of water slake one pound of lime in a little water; when slaked add a half gallon more water, strain it through a coarse cloth—a piece of gunny-sack will do—and pour the liquid into the barrel of poisoned water, and stir thoroughly. The lime prevents the arsenic from injuring the leaves of the more tender varieties of apples, and it also shows which trees have been sprayed and whether the job was thoroughly done. I have had better success in combating insects injurious to the apple with this mixture than with any other, and when applying do not fear that I am wasting time, as is sometimes the case when Paris green or London purple is used.

\*\*\*

**Spraying the Orchard**

Hundreds of people who own small orchards would like to spray their trees, but are deterred therefrom by the cost of a spraying outfit usually recommended by writers. For spraying a few trees all the outfit that is necessary is a barrel to mix the poison in, and a small sled. One made of two planks four feet long will do. Lay them side by side and fasten them securely together by means of strips of board nailed across them. Clip off the under side of the front edges, set the barrel on it, mix the spraying materials, and with one horse draw it into the orchard and wherever needed. A good spray-pump for a few trees does not cost much; a piece of half-inch rubber hose about eight feet long, having the spraying end attached to a light stick the same length, will raise the nozzle high enough to spray most trees. If the trees are very large, one can climb into them, draw up a bucketful of mixture, set it firmly among the branches and send the spray over the entire tree.

\*\*\*

**Poultry Pests**

It is time now to begin an active warfare against the pests that infest the poultry-house and coops. The nest-bug and red mite are the worst pests. Cleaning out the nests and thoroughly spraying them with kerosene or kerosene emulsion about every ten days will keep these two pests checked. It will also be necessary to spray the entire interior of house and coops at the same time, and especially the perches. If spraying does not seem to be effective it is because it is not well done. Particular attention should be paid to all cracks and chinks, for there is where the pests hide. Drive the kerosene into them with all the force at your command. Unless these pests are kept in subjection they will overrun the entire premises, and not only kill young chicks and stop the production of eggs, but make it mighty uncomfortable for the farmer and his family.

FRED GRUNDY.



## OUR FARM

### FARM THEORY AND PRACTICE

**A** MANUAL OF FARMING.—Farming is a broader business than many people realize. They seem to think that some one should be able to tell them just what to do under all circumstances. A few of our farm writers are catering to this demand by undertaking to give absolute directions for building up a soil they have never seen, and for cropping it to the best advantage. It will not do. Success will depend upon too many factors unknown to the stranger. The one who goes into partnership with Nature to secure a livelihood from the soil cannot depend upon any cut-and-dried rules for his guidance. His course each day must depend upon prevailing conditions that cannot well be foreseen even by the most experienced, and that are wholly without the vision of the man who has not had local experience. The province of the farm paper and farmers' institute is to discuss general laws of Nature, to open our eyes to the great field of study, to fill us with an enthusiastic desire to master our local conditions, to present the known truths of general application, and then to show how some individuals are making use of these truths and the knowledge they gain from the study of their soils and crops to make money. The farmer gets hold of the underlying laws of growth, he sifts the experiences of others, and then he reasons out the best method for himself. The more he knows of Nature's laws, and the more he studies others' experiences, the better equipped is he for modifying his practice so as to secure the best results. But to be a machine, to imitate another without considering differences in conditions, to follow fixed rules without modification, to ask for a manual of farming—it is folly.

\*\*\*

**REMOVING BOTH CROPS OF CLOVER.**—The question is often asked, "Is it good farming to cut both crops of our common red clover, one for hay and one for seed? What does the land gain from a clover crop handled in this way?" I believe that it always pays to cut the first crop of clover for hay if one has stock to be fed and saves the manure. If the hay is made as early as it should be there is a much heavier second growth than there would be if the first crop were left uncut, and the belief is that the root growth of the plant is stimulated in this way. The plant lives for reproduction, and puts forth its best effort to make a full crop of seed to insure reproduction. It is good farming to take off the first crop of clover for hay if the fertility left from feeding goes back to some soil on the farm. The feeding value of a ton of clover is a big item, and a large part of this is clear profit. The second crop contains the seed. If there is enough net cash to be gotten from it to pay for restoring to the field all the fertility removed, and also the organic matter if the soil needs it, and if the owner of the field will do this and not let the soil suffer by reason of making the second crop of clover a cash crop, then it is a plain business proposition. For a limited term of years land is made more productive by a clover crop, even when both crops are sold off the farm, but the drafts made by the clover are heavy, and eventually the soil is impoverished by such a course. Most land needs organic material, and this is not returned satisfactorily in the halm of the second crop. Where land is under a short clover rotation, and clover is the chief dependence for fertility, all except the hay crop should go back to the soil if one would maintain fertility, and the manure from the hay should go back without any needless waste. If clover is intended as a fertilizing crop it cannot be used at the same time as a cash crop without future disappointment. It is usually safest and best to be liberal with the soil that feeds us.

\*\*\*

**OUR CORN CROP.**—While hundreds of millions of bushels of corn are grown for market, the greater part of the corn crop is produced by those who

have a comparatively small acreage and want the most feeding value for the farm stock. Such farmers are learning to put a high value upon the fodder, and the varieties of corn and methods of planting that are best for the extensive grower that markets his grain are not always the best for one who needs the fodder as well as the grain. The latter is learning that the variety making the heaviest stalk and biggest ear is not the one that suits him best. Some of the smaller varieties make about as much grain because the number of stalks to the acre can be increased somewhat, and while the expense of husking is slightly greater, the extra feeding value of the fodder more than compensates. Of course, it would be easy to lose money by going to any extreme along this line, but within certain bounds the smaller variety, with a fourth more stalks an acre, will produce about as much grain and much more total feeding value an acre for the man who cares for his fodder as he would for hay or other valuable feed.

Many feeders have a prejudice in favor of the yellow color in corn that is not borne out by careful experiments. Some varieties of yellow corn are richer than some varieties of white corn, and similarly, some varieties of white corn are richer than some varieties of yellow. Tests show that color is no index of feeding value. This is one of the facts that can be definitely ascertained by our scientists. Variety and soil fix the feeding value, and the color has nothing to do with it.

Corn uses a vast amount of water in its growth, and rather late surface cultivation is pretty sure to pay, both because it helps to hold moisture and because it prevents weed growth. A weed could be spared what plant-food it takes, probably, in fertile corn-land, but it cannot be spared the water it wants and will take if left standing. Every weed pumps water into the air.

DAVID.

1

### WHEELBARROW GATE

What an unsightly thing about a farm is a big gate that is hardly ever closed. No matter how heavy, a gate with wheel attached, as plainly shown

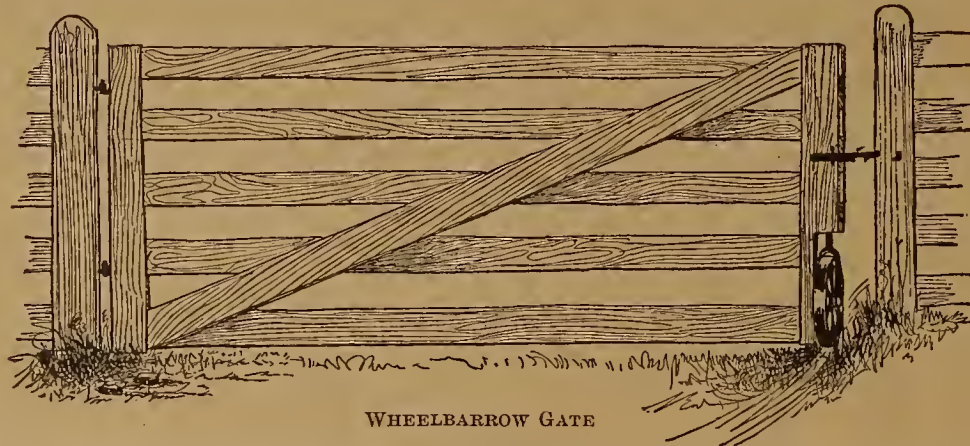

WHEELBARROW GATE

in the accompanying illustration, is easy to move, and does not sag or get out of order.

W. S. S. YOUNG.

2

### WHERE TO FIND SHEEP-LANDS

There is soon to be, from every indication, a greater expansion of the sheep industry in the United States than was ever known before in our generation. Enterprising men are now looking for places to establish themselves. Of course, everybody is looking to the West—away off, and not at home, where thousands of acres of thin lands, poor lands, as they are rated, that cannot be expected to grow great crops of corn and wheat and remain fertile very long. But these lands are fertile, and with good treatment will be valuable grass and pasture for all time.

To illustrate: Let me tell of one such experiment that well demonstrates this proposition here in Illinois. I know a very manly man who has been quietly laying the foundation for a most delightful and successful sheep-farm. There are hundreds of wooded creeks running out into the prairies say from one to three or four miles wide. These lands are divided into ten to forty acre tracts, and are owned by farmers for wood and timber supplies. They care nothing for the land—only for this, and nothing more. Their value is of no importance. Our friend, with an eye to business, began with a small tract and a small flock of active,

hardy, healthy young Merino sheep. He selected these because, as he knew, they were hard workers and could make a living on any pasture that could keep a goat or rabbit—a woods pasture. The feed supply was wild rough grasses, weeds, buds and sprouts of oak, hickory, sassafras and hazel—wild stuff that he knew sheep were fond of nibbling, and such stuff as the eye of a sheepman and sheep only would see. The first year, with some grain to supplement the pasture, proved a notable success. A good clip of wool, a crop of strong, hearty lambs made his heart rejoice, and he took courage and went ahead.

I omitted to say the forty acres were well fenced, and blue-grass was encouraged, and brush and briars were discouraged with ax, scythe and the sharp teeth of the sheep. Grass—mixed sorts—and white-clover seeds were sowed everywhere and results noted.

Another piece of land was bought and some more sheep added. The next year was even more prosperous. Wool, lambs and the culls—aged ewes and those that failed to bring and raise lambs—were sold. From the first all ram lambs went to mutton just as soon as they would sell, and the ewe lambs were kept for breeders. It was the rule to dispose of all ewes at four years. This kept the flock young and vigorous. Only Merino rams were used, and these of the mutton type—good shearers, plain, blocky, thrifty, with good constitutions. Size was not at first valuable, from the fact that smaller sheep were the best workers and quickest to mature. The flock was a paying investment. More wood-lots were bought, fenced and put under the system of pasture-making. Some corn had been raised at first for winter feeding until blue-grass pasture could be reserved for winter only. Then corn was bought, which could be bought cheaper than he could raise it. Blue-grass and white clover were the main dependence, but if at any time the sheep needed corn they got it.

Some prairie farmers would not part with their "wood-lots," but would lease the land, provided a gate was built, so they could come and go at pleasure.

It came about that somebody's tract would be surrounded by tracts already bought and fenced. They were willing to use gates, provided roads were not disturbed, but fenced in good style; and all was harmony in this prosperous sheep-ranch.

The last time I talked with this delightful gentleman he was using three miles up and down this little wooded stream, the most of which he owned, and all stocked with sheep. What this man did can be done thousands of times over both in Illinois and many other states. And why not? Waste lands are not wasted because they cannot grow corn from generation to generation.

R. M. BELL.

3

### DAIRY EXPERTS AT THE INSTITUTES

One of the experts at the New York farmers' institutes was G. A. Smith, dairy instructor at the New York experiment station. The following points are selected from notes taken when working at the institutes:

Mr. Smith, speaking on the subject of "Cattle Foods," said dairymen are working under different conditions than they were twenty years ago. With the low price of butter, made by the large production and the competition of oleomargarine, there is no longer much profit for Eastern farmers to buy Western grain to feed their cows, or in practicing the old methods of dairy-farming. There were seventy-

four million pounds of oleomargarine consumed last year in the United States. This has taken the place of so much butter that would have been consumed if the oleomargarine had not been in the market. There are many dairies where the income of a cow is not over \$20. Farmers with these dairies sell their farm crops to the cows for \$10 a cow less than their value. In the end such a practice can only ruin the farmer. On many farms in the milk-selling sections the plan of farming is to buy a bag of grain, and with it make a can of milk, thus making an endless chain. The grain costs about all that is obtained for the milk, and there is little profit in the business. One way to increase the profits is to grow more of the feed on the farm. The carbohydrates in the form of ensilage, hay, etc., should, of course, be all grown on the farm, also the protein crops to balance them, so but little grain need be purchased. Oats and peas, clover and alfalfa are valuable crops to grow, because of the protein they contain.

Mr. F. E. Converse, speaking in the same line on the subject of "Breeding and Feeding," said that much depends on the choice of breeds. Some farmers having hill pastures are making the mistake of keeping the larger breeds, like the Holsteins. Better keep the smaller breeds, as the Jerseys and Ayrshires. It will pay you to get the best-bred sire you can afford to buy, then breed to your best cows. When feeding and caring for the cows in winter think what the conditions are in a day in June, when the cows have plenty of grass, plenty of water and sunshine, then make the environment in winter correspond to them as nearly as possible. Provide succulent food, a balanced ration, warmth and sunshine.

Mr. Jared VanWagenen, an expert butter-maker, gave some points in butter-making, as follows: First, we want good, clean milk that is not kept under conditions favorable to the development of bacteria. Lack of cleanliness in the stables and in the care of milk are the causes of the increase of the bacteria in the milk, which makes so much trouble with the milk and its products. All milk-utensils should be scalded before using. Get the milk clean, put it in clean vessels, and cool it as quickly as possible. Every butter-maker should have a Babcock tester, a cream-separator and a revolving churn, either barrel or box. The churn should be stopped at the right time, and this is when the granules are the size of a grain of wheat. Wash the butter just sufficiently to get out the buttermilk, using plenty of ice in summer; but in the winter make the water as warm as you can, and have the granules compact. In salting the butter I do not think any fixed rule can be followed. Sometimes the butter has more water in it than at other times. The amount of salt should vary from one and one half ounces to three fourths of an ounce for a pound of butter, according to its firmness. I advise partly working the butter in the churn, then finish with the butter-worker. Butter is worked enough when it breaks readily by doubling over when it is spread out in thin layers. Success in marketing butter will depend on having the packages neat and tasty, in having butter of the best quality, and in using a mark with the name of the farm on it.

W. H. JENKINS.

4

### DRAIN-OUTLET KEPT CLEAN

Frequently it is necessary to place the outlet of a tile-drain where there is insufficient fall to insure against clogging of the mouth with silt and mud, and thus impairing the efficiency of the drain. Such trouble may be overcome by sinking a large vitrified drain-tile or sewer-pipe immediately in front of the opening, and if stock are permitted access to the place, setting plenty of stone around the outside, so as to make firm footing. But stock should not be allowed to approach the place, because of the danger of their getting into the hole and being injured. Very little trouble will be experienced in keeping this silt basin clean, much less than digging up and cleaning out several yards of settlings in the tiles.

M. G. KAINS.



## NOTES FROM GARDEN AND FIELD

**SMALL PRESERVING-TOMATOES.**—Perhaps I am not quite up to the times, otherwise I should have known of the "blue-husk tomato" about which a reader inquired some time ago. I hold at least half a dozen letters from readers who tell me that such a tomato is in existence. Mrs. E. C. H., of Connecticut, forwarded also some of the seeds of this plant, and I shall have the pleasure of testing it this year. Some of the correspondents call it "blue-husk, or plum, tomato." Another calls it "purple-husk tomato." The yellow-husk tomato, or cherry tomato, as it is often called, has a decidedly sweetish taste. This blue variety is said to have more acidity. We never have had any trouble to ripen the yellow one, even when the plants came up from self-seeding in the garden, and this rather late in the season, for the seed will not germinate until the ground gets good and warm. My correspondents tell me that the plants of the blue one should be started early, else the seed will not get ripe. A lady in Iowa writes that she had this fruit plentifully thirty years ago in Adams county of that state. "It is the size of a large plum, and grows inclosed in a thin husk, which fits it closely, and is of a dark blue color. It makes fine preserves."

**CELERY-PLANTS.**—A reader asks me to sell him celery-plants. I usually have good plants; but I am of a selfish disposition, and prefer to use them myself. In fact, I let no plants go out even to neighbors if I can get around it. I am not in the business of commercial plant-growing, although I realize full well that there is good profit in it when a regular trade has once been worked up. The best thing I can do with good plants, and the most profitable to me, is to set them and grow a good crop. I do not care to prepare for packing and shipping an occasional lot. But there are a great many people who do. The advertising columns of agricultural papers at this time contain many offers of plants at reasonable prices. There is where the reader should look for a chance to purchase his stock. For this season it is too late to start celery-plants from seed. For the earliest, or summer, celery (ready for the table late in July or in August) I sow seed of Golden Self-Blanching or White Plume in flats under glass during the latter part of February, always in rows as closely as they can be made conveniently, and putting the seed rather thinly in the rows, then covering lightly. Just as soon as I can prepare a very rich piece of ground outdoors the little seedlings are transferred to the garden, cut out in blocks or bunches from the flats, and set in rows so as to stand not more than ten to fifteen to the foot of row. I used to let them stand more thickly heretofore, but find it much better to give them more room. Should the weather be very hot and dry it will be advisable to provide a little shade and a good deal of water. A little nitrate of soda is scattered along the rows to push the plants into early and strong growth. Besides this, I use water from a barn cistern for watering these plants. This water has a yellow or brownish color from the pigeon droppings, which the rain and snow-water has washed from the barn roof, and which are dissolved in it. It has a great effect on plants. In June (sometimes even in the latter part of May) the plants are ready for setting out for a crop. Select the richest soil, and the best manure for enriching that soil, and set in rows, not less than eight inches apart in the row if you aim for largest size of stalks. I often set two rows together, with seven or eight inches space between them, thus making one job of blanching the two rows. The distance between the rows, or between each set of two rows, is determined by the method of blanching. If blanching by means of boards set up on each side of the row or rows, the space between may not be more than eighteen or twenty inches. But if the rows are to be earthed up more space will be needed.

**SOME GOOD CHERRIES.**—A fruit which I hold in high esteem for dessert and to eat out of hand is the cherry, especially the sweet ones. I like those large, luscious Oxhearts. But it is only now and then that I secure a good crop of any of my sweet sorts. Worms, rot and birds take them all. In the occasional seasons that give me a full crop I get my full share in spite of robins, cedar-birds, sparrows, etc., because there are enough for all. But when the crop is short birds get the lion's share even if the cherries do rot. Mr. Willard recommends the Windsor cherry as one of the most valuable sweet ones ever given to the orchard. No other equals it. It is a dark-colored cherry, and these are not so liable to decay as the light-colored ones. It is large, hard-fleshed, and the tree of great vigor and resistant against disease. Along the Hudson it ripens from the sixth to the tenth of July. Of course, the tree comes high. I believe nurserymen ask about one dollar for it. Yet I feel that I must have it. Of the sour sorts I have mostly Montmorency ordinarie and English Morello. These are good sorts, indeed the best, but in late years I have been much bothered with rot, and also with the black-knot. A state law commands us to keep the knots out of plum and cherry trees, but it is only done in exceptional cases.

\*\*\*

**MUSHROOM-GROWING.**—Probably the majority of people who try to grow mushrooms in the cellar or in a greenhouse will never brag over their success. Failure is the rule rather than the exception. And yet it is an interesting field for experiment. Now, if you have made a failure of growing these delicious fungi under the greenhouse benches, try them once on the bench, say among a crop of lettuce. It seems much easier to grow them there than in any other place I ever tried them. A good plan is to place a good layer of prepared manure, or add well-rotted manure in the bottom of the bench, and on this a layer of soil made of a mixture of old sods and manure. Spawn the bed as you would a bed of manure prepared especially for mushrooms, and water moderately by sprinkling, never by soaking. Then grow your lettuce-plants in the usual way, and you will be likely to have both lettuce and mushrooms in the same bed. I had a very good supply last year grown in this way. The mushroom books do not tell us anything about this easy method of mushroom culture. And, by the way, a reader in Lakewood, N. J., asks whether I have a book on mushrooms, and by whom it is published. I once planned the publication of "the new mushroom culture," but fortunately never committed this sin. There are now some good works on mushroom-growing in existence. One is written by my friend William F. Falconer, and published by the Orange Judd Company, of New York. Another is a ten-cent pamphlet issued by "American Gardening," of the same city. The department in Washington and several of our experiment stations have also issued bulletins on the subject, which are useful and interesting, and may be had from them gratis or at a nominal sum.

T. GREINER.

### INQUIRIES ANSWERED

BY T. GREINER

**Root Crops and Onions.**—W. C. A. Kamiah, Idaho, writes: "Last spring I planted parsnips, carrots and stock and table beets side by side on the same kind of ground. All received the same attention, but the parsnips and beets hardly paid for gathering, while the carrots made about twenty tons to an acre. The soil is heavy black loam; it was broken first in 1898, and laid till last spring, then was plowed and put in good shape. Do parsnips and beets need different soil or treatment from carrots? A quarter of an acre of onions did not ripen on account of a short, wet season. What will they amount to if left in the ground another season?"

**REPLY:**—We have usually been assuming that parsnips, beets and carrots will thrive under approximately the same conditions. Beets can stand heavier manuring than carrots, but I raise carrots by the side of beets and have good crops of both. Decayed sod-land, however, seems to suit the requirements of a carrot crop exactly. The onions if left in the ground the second season will go to seed. They may be pulled and bunched for green onions early in the season.

## ORCHARD AND SMALL FRUITS

CONDUCTED BY SAMUEL B. GREEN  
INQUIRIES ANSWERED

**Osage-orange Seedlings.**—D. W. M., Appleton, Wis. Osage-orange seed should be soaked for a few days in warm water before sowing, and then sowed in the open ground. Another very good way to treat it is to mix it with wet sand kept in the house in a warm place. This should be stirred frequently, and as soon as the seed shows signs of germinating it should be planted.

**Borers.**—D. E. H., Ashtabula, Ohio. The piece of bark and wood of the quince-tree which you inclosed is infested by one of the small bark-borers. The best remedy is to cut off and burn the infested portions. If you are troubled about finding the borers that are working in your cherry-trees I would suggest that you get a little bisulphid of carbon, put it into an oil-dropper, squirt it into the holes, and seal the holes up tight with putty or grafting-wax. While this will not always work successfully, yet if it is done carefully it will generally destroy the borers.

**Curculio—Clover or Rye.**—C. E. E., Watertown, Ohio. I think your plums fall from your trees because they are infested with curculio. The best remedy for that is to jar the trees in the spring, commencing as soon as the flowers fall, and gather the beetles which are thus shaken off onto sheets laid on the ground under the trees. This is considered by all the large plum-growers as the best way of fighting this insect. Spraying with Paris green has had its advocates, but on account of the great liability of the plum foliage to serious injury from it, it has generally been given up.—Clover will improve the land far more than rye.

**Protecting Plums from the Curculio.**—D. T., Kirkersville, Ohio, writes: "Could plums be protected from the curculio by covering the tree with thin butter-cloth?"

**REPLY:**—Plums may be protected from curculio by covering the whole tree with cheese-cloth, or, better yet, with mosquito-netting, although it would be rather an expensive and clumsy way of doing. The cheese-cloth will not injure the plums, but there would be some danger of the foliage becoming diseased if it is kept on very long into the season, as the leaves would not get the proper amount of sunlight. A better way for you to do, I think, would be to lay down a couple of sheets, one on each side of the tree each morning, and just strike the branches sufficiently to jar them a little, when the curculio will fall to the ground and may be gathered and destroyed.

**Barked Trees.**—M. F., South Pittsburg, Tenn. The apple-trees that have had the bark gnawed off by sheep may be difficult or easy to save, according to their condition. If the sheep have not gnawed off the inside bark entirely, so that there is still considerable connection between the upper part of the tree and the lower part through the inside bark, they can be quite easily saved by covering them with clay, or, in the absence of clay, with a heavy coat of white lead or grafting-wax, and then wrapping the trunk with hurlap, so as to prevent the clay or white lead from falling off. If you cannot save them this way it is doubtful if it will pay you to go to the expense and trouble which will be necessary in order to insert grafts to bridge over the wounds. A mixture of clean, fresh cow manure and clay well kneaded is most excellent for covering tree wounds, and would be desirable for your purpose.

**Leaf-eating Worms on Willows.**—S. B. J. There is no variety of willow that can be considered proof against the leaf-eating worms which attack that genus. The best willow for general planting in Minnesota and the Dakotas is undoubtedly the well-known white willow. It is true that it is liable to be injured by leaf-eating insects, but the same treatment that is given to potato-vines to keep off the potato-bug will keep the worms off the willows, and I should not hesitate to grow them on account of liability to the attacks of these insects. The application of Paris green and water to the trees infested will destroy the worm, and it is seldom that more than two applications are necessary in a season, and then not over all the trees in a hedge. In case of rather tall trees a special arrangement should be made for the application of Paris green. This should consist of a good force-pump fastened to a barrel, which can be set in a wagon, and by use of a piece of hose ten or twelve feet long, which can be held aloft by means of a light pole, it is quite an easy matter to spray all the trees.

**Rose-bugs on Grape-vines.**—M. H. P., Spring Lake, N. Y. Occasionally for a number of years rose-bugs appear in ever-increasing numbers, until the swarms are so great that they ruin not only vineyards, but orchards and gardens, eating almost every kind of fruit and flower. At such times we are almost helpless, and insecticides act too slowly to be of any use. At such times the best treatment is that of jarring the vines and trees after spreading sheets on the ground under them. They readily drop when jarred,

and should be collected and thrown into kerosene. This must not only be done daily, but continuously for several days, until the flight is over or the grapes are set. After such a great increase there will come a series of years in which there will be very few of them. The larvae feed in light soil on the roots of various plants, but principally on the roots of grass. They pupate in the spring shortly before they change to the adult stage, and by plowing infested sod at this time a large portion can be destroyed. When only moderate numbers occur lime serves fairly well to protect the plants, but Bordeaux mixture is much more satisfactory.

**Pruning Apple-trees.**—J. S. J., New Wilmington, Ohio. It is impossible to lay down exact rules for pruning, as no two varieties of trees are liable to fit the same rule. Apple-trees should never be given too severe a pruning at one time, and particularly so if given after the buds start. The best times for pruning are in February and March, and again between the fifteenth of June and the fifteenth of July. The pruning should only be sufficient at any time to keep the tree in a well-balanced, symmetrical form and keep the head sufficiently open to give free access to light and air. It is the best where large limbs are to be removed to do the work in the latter part of winter. If done in summer care must be exercised to not remove too much foliage at one time. Where branches cross each other and chafe one should be cut away. It is in order to remove water-sprouts as fast as they appear, and if they are kept off, and surplus branches cut away while yet small, heavy pruning will rarely ever be needed. All branches should be cut as close to the trunk or larger branch as possible without making a wound larger than necessary. They should be cut away with a sharp saw, the wound smoothed over with a knife, and in the course of an hour or two covered over with shellac dissolved in alcohol, or white paint or common grafting-wax. Remember, it is better to prune a little at a time than to do up a big job all at once.

**Pasturing an Old Orchard.**—F. E. G., Groton, Mass., writes: "I write to ask your advice about an apple orchard. It is an old orchard, and the trees are large, but in good bearing condition. It has been used as pasture for sheep in the spring and fall, when they have been fed some at the barn. The ground this spring is almost half covered with green moss, which does not allow much feed. The soil is a naturally good clay loam. Please tell me what to do for the orchard and at the same time keep it for a sheep pasture."

**REPLY:**—The old orchard which you wish to use as a pasture in the fall and spring undoubtedly should have the sod in it broken up, and it probably needs manuring or the land would not be so filled with green moss. The proper treatment of your orchard would be to break up the sod, seed down to some forage crop, like huckwheat or vetches, and when these have made their full growth plow them in. This will give the soil the humus which it needs, and will start chemical action in it, all of which is lacking at present; but in this case you could not pasture your sheep. However, you should hardly expect an orchard to produce a good crop of mutton and a good crop of apples at the same time. It is almost out of the question. You may be able to sort of combine the two, but you never can have the best success with your orchard under such conditions.

**Marketing Strawberries.**—J. H. M. In handling strawberries for marketing the first thing to bear in mind is that you must adapt yourself to the market in which you intend to sell your fruit. Throughout most of the Mississippi valley the package demanded is what is known as the "gift package," containing sixteen or twenty-four quart boxes. The berries should be picked daily in warm weather, and in cold weather the bed should not go more than two days without picking. Great care should be taken not to put any overripe berries in the boxes; in fact, it is far better to have the berries partly green than to have them overripe, as one overripe berry in a box will very likely result in the loss of all that are with it. Great care should also be taken to keep the berries clean and free from dirt. To this end it is very desirable to mulch them so that the dirt will not spatter upon them in case of rains. The berries should be picked with a portion of the stem, and the hulls should never be broken off. Do not put in small or deformed berries, for they will not pay for shipping, and if they are mixed with good berries they reduce their price very considerably. The box should be well filled, and care should be taken that the berries on the top of the box are fully as good at least as the berries in any part of it; in fact, it is a good plan to pick off any poor berries that may be on top of the box and replace them with some that are extra good. The difference, however, between the top berries and those below should not be sufficiently evident so as to be deceptive. In keeping track of the pickers a number of systems are used. Perhaps the arrangement by which each picker has a card which is punched for every case of berries picked is as good as any, but it matters comparatively little what system is followed in regard to this, provided the work is well systematized so that the accounts are carefully kept.



## THE WAGES OF THE HIRED MAN

At a glance it would seem that the farm-hand, compared with other young men, was not receiving just compensation for his time and labor. A young man of medium ability can easily command from \$30 to \$40 a month in store or counting-house—that is, as soon as he has served his apprenticeship and has learned something of the run of business. A young man drawing a salary of from \$50 to \$60 is nothing unusual. The farm-hand cannot come up to this. The average farmer cannot boast of an income to exceed these figures, much less pay a man the wages. For that reason it would seem that no young man could afford to hire out to the farmer. Yet a careful viewing of all sides of the question will show why so many men—prosperous farmers of to-day—got their start by working as "hands" on the farm.

A good man on the farm can get from \$18 to \$20 a month. This, of course, includes board, which the clerk must pay for out of his salary. This will add about \$15 a month to the farm-hand's wages. Then there is the question of dress, which is no small item, for the young man about town cannot go about his business in the coarse clothes that the farmer, by the nature of his work, is forced to wear. The difference in the first cost is not a small item; and when it is taken into consideration that the farmer can wear his clothes until worn out, while the city man must discard his as soon as frayed or soiled, there will be little doubt as to the relative sizes of the two clothing bills. Then there is the laundry bill—the hired man's washing costs him nothing, as it is thrown in; the barber bill; the tickets for the theater and other entertainments; cigars, and other items which the young man of the farm is not called upon to meet.

The hired man's salary plus his board will amount to at least \$35. Add to this his dress-saving, barber, theater, cigar and other bills, and it will easily amount to \$50; no small salary when it is taken into consideration that he is learning his business, and will be ready to start for himself as soon as he has a bank account that will warrant his setting up for himself. The fact that he doesn't handle all the money really means nothing. It is not what a man makes, it is what he saves.

The average young man has not the educational abilities to draw such a salary as this in a city. A man with practically no education can command the best of wages as a farm-hand if he is trusty and faithful. The clamor that the farm-hand is not paid enough is not just. The farmer pays all he can afford to, and often more than the hand is worth to him. A little thought upon the subject will convince one that this is not the solution of the question, "Why are there so few good hands to be had to-day?"

J. L. IRWIN.

## HOME-MADE TRELLIS

A satisfactory trellis for such straggling house-plants as nasturtiums and wandering-jew may be made at home more easily than the following description seems to imply.

Around a cylinder of wood or other substance of about the same size in diameter as the trellis is to be, wind number twelve or thirteen galvanized wire rather tightly. For each turn calculate a height of not less than one inch. For example, twelve turns will make a trellis a foot high. After the last turn bend the wire down at right angles to that already wound on the cylinder. The length will depend upon the size of the pot, and the plant to be grown in it. About three inches longer than the depth of the pot will be found convenient. At the lower end make a circular loop of slightly smaller diameter than the bottom of the flower-pot it is to be placed in and bend it at right angles to the upright piece. Now loosen the wire around the cylinder, twist the upper end where it meets the first round of the wire, draw out the coils spirally as much as desired, and the trellis is complete.

M. G. KAINS.

Kansas and Wisconsin are sending creamery-butter in car-load lots to the city of Manila.

## CORRESPONDENCE

FROM IOWA.—Linn county has a variety of soils—red clay, sand and sandy loam. It is principally a dairy region, but many hogs and steers are fed in connection with dairying. We raise corn, oats and timothy. We have good markets for all we raise. Unimproved land is worth \$40 an acre; improved, \$50 to \$60. Many farms rent at from \$2.50 to \$3.25 an acre; some are stocked, and renter and owner divide the profits. Farm-hands get from \$18 to \$20 a month.

B. H. Wanbeck, Iowa.

FROM WASHINGTON.—To those living in cold, rigorous regions Klickitat county offers great inducements. Home-seekers can get here a cheap, comfortable home in a mild and healthful climate. Improved land sells at from \$5 to \$20 an acre. Wheat-raising is the main business. Dry harvests make it very easy to care for the crop. The usual yield is twenty bushels an acre. This country is becoming famous for its fruit. Lumber is cheap. Fuel costs only the work of cutting and hauling from the mountains. This is not a very good place for men who depend on daily labor, as there is not steady work; but farmers whose hopes have been so often blasted by tornadoes, blizzards, hog-cholera, etc., if they only knew of the advantages and comforts enjoyed here would quickly find their way to this beautiful valley.

Goldendale, Wash.

W. E. H.

FROM OREGON.—It is two years since we came to Oregon. We have an even climate, never hot nor cold. It rains enough to produce good crops each year. Tame grasses of all kinds yield abundantly. Two years ago we cut twenty-eight tons of clover hay from ten acres. We live twenty-eight miles from Portland. We can see Mt. Hood with its snow-capped dome every day in the year. We have one of the best stock countries, and sheep are fast taking the lead. Potatoes can't be beat in quality, quantity and size. Strawberries and berries of all kinds bear longer than back East. Grapes, plums, prunes, pears, cherries and apples bear abundantly. There are several nice places for sale at \$30 an acre. Some owners are too old to farm, and others too poor to improve their places. We have a timber country—oak, pine, cedar and fir. Our timber will soon be sought after for all kinds of building purposes. We raise wheat, hops and poultry successfully.

Molallo, Oreg.

A. F. Y.

FROM KANSAS.—I will say to any one expecting to come to Kansas, do not think that money grows on trees, or that you can plow it up. I think a dollar is as easily made out here as it is in Ohio, but not any easier. I thought that I could plow all day and never see or strike a stone, and that the land was as level as a floor. Now, we have level land and we have rough, hilly land. This is in Douglas county, counted as good as any of the counties for general farming. There is one thing out here in the land, cold hard-pau, that we find right at the side of as good land as we have in the West; and I tell you when a plow strikes it, it is a sticker. A team of horses cannot pull it at the same depth. Another drawback is the chinch-bug. I have lost eight hundred bushels of corn in one season where there was wheat in an adjoining field on a neighbor's farm. I do think that we farmers should quit the wheat business entirely. I have turned my attention to raising corn and feeding it to hogs. I find it much more profitable. If you are coming West, do not let this discourage you. Just come, and you will find lots of good people out here, but you can once in awhile strike a man who will help you to spend your dollars and leave you without any value received.

J. A. D.

Lawrence, Kan.

FROM FLORIDA.—My native state is Ohio. I had a had case of catarrh and bronchial trouble, with incomplete circulation. I spent a great deal of money doctoring, and traveled over a large part of the country seeking relief. In 1894 I visited Florida during a part of the winter, and was so much improved in health that I have spent every winter here since 1894. I traveled all over this state, and in 1896 I bought a little home on the "Lake Polk Hills," three and one half miles due east of Bartow. These hills have an elevation of two hundred and fifty feet above tide-water. I have spent the whole of the last two years here, and I prefer a Florida summer to that of Ohio; and a Florida winter is so far superior to an Ohio winter that I believe it would justify all who are financially able to spend their winters here. I am enjoying better health now than for twenty years past. Nearly every one can make a living. Cattle, hogs, sheep and poultry do well with little care. We can raise almost everything that can be raised in the North, and a great many things that cannot be grown at all in the North. Our strawberry season is on for almost six months. Our chief production is citrus fruits. I don't believe that there is a locality on earth that can beat this section in the production of fine-flavored, thin-skinned oranges. Land is valued at from \$5 to \$5,000 an acre, owing to location and improvements.

D. C. G.

Bartow, Fla.

## WALTHAM WATCHES

Over twenty-five years ago the American Waltham Watch Company stated that "350,000 Waltham Watches are speaking for themselves in the pockets of the people." To-day EIGHT MILLION Waltham Watches are in use throughout the civilized world.

Waltham Watches are for sale by all retail jewelers.



**"Kilfly"**

Protects Cows and Horses from torture of Flies. A liquid mixture of untold value. Absolutely harmless to man or beast. A thorough disinfectant and germicide destroying all bacterial germs thereby insuring health, greater strength and vigor to the animals which with relief from the pestering flies greatly increases the amount of milk and affords much comfort to cows and milkmen. Used with equal effect on horses.

Easily and rapidly applied with **CHILDS' ELECTRIC SPRAYER**. Convenient and practical in every particular. Sold only in one gallon cans sealed with our **KILFLY** label and signature. Beware of imitations. Ask your dealer or send \$2.00 for gallon can **KILFLY** and electric **SPRAYER** securely packed and express paid to any point east of Mississippi river, except in Maine.

Chas. H. Childs & Co.  
Sole Manufacturers,  
18 Lafayette Street,  
Utica, N. Y.

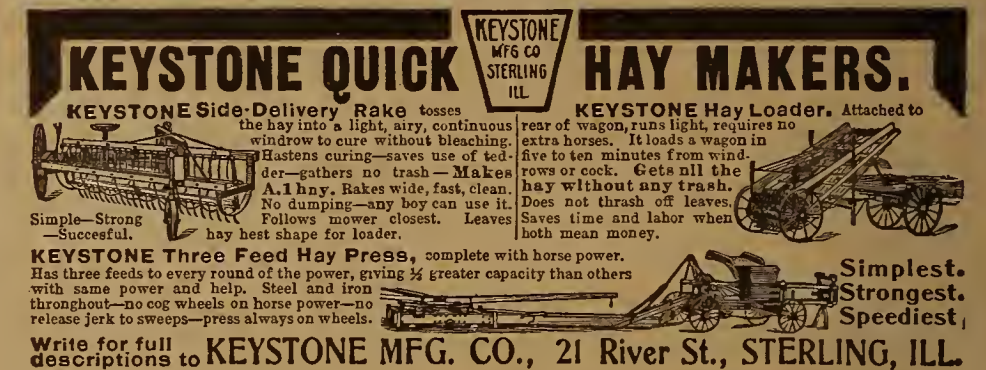

**KEYSTONE QUICK HAY MAKERS.**

**KEYSTONE Side-Delivery Rake** tosses the hay into a light, airy, continuous windrow to cure without bleaching. Hastens curing—saves use of tedder—gathers no trash—Makes A. 1 hny. Rakes wide, fast, clean. No dumping—any boy can use it. Follows mower closest. Leaves hay best shape for loader.

**KEYSTONE Hay Loader.** Attached to rear of wagon, runs light, requires no extra horses. It loads a wagon in five to ten minutes from windrows or cock. Gets all the hay without any trash. Does not thrash off leaves. Saves time and labor when both mean money.

**KEYSTONE Three Feed Hay Press,** complete with horse power. Has three feeds to every round of the power, giving 1/2 greater capacity than others with same power and help. Steel and iron throughout—no cog wheels on horse power—no release jerk to sweeps—press always on wheels.

Simple—Strong—Successful.

Simplest, Strongest, Speediest.

Write for full descriptions to **KEYSTONE MFG. CO., 21 River St., STERLING, ILL.**

**WHY PAY \$60.00 MORE**

for a surrey than is actually necessary. If you buy a job as good as good from a dealer or agent he will charge you about that amount in commission. Buy direct from our factory and save it. We are the largest manufacturers of Vehicles and Harness in the world selling to the consumer exclusively.

**WE HAVE NO AGENTS.**

We make 178 styles of vehicles and 65 styles of harness and ship anywhere for examination, guaranteeing safe delivery. You take no risk, as all our work is guaranteed as to quality, style and finish. You have the advantage of the largest stock in the country to select from. Don't buy a vehicle or harness of any kind until you get a free copy of our large illustrated catalogue.

No. 77—Single Surrey Harness. Price, \$17.50. Equal to those selling for \$10 more.

No. 911—Canopy-top Surrey, has long-distance axles, open rubber head springs and Bradley quick couplers. Price, complete with curtains, storm apron, sun shade and fine lamps \$135. As good as others sell for \$50 more than our price.

**Elkhart Carriage and Harness Manufacturing Co., Elkhart, Indiana.**



**AMERICAN GOLD FILLED WATCHES** Are... the Lowest

Before you buy a watch it will not cost you a cent to see our great bargain. Send your name, post office and express office address, and we will send you by express for examination a handsome **WATCH and CHAIN COMPLETE G. O. D. \$4.50**

Ladies or gents size, double hunting case beautifully engraved, stem wind and stem set, accurately adjusted, expansion balance, warranted a perfect timekeeper. If you do not consider it equal in appearance to any \$40.00 gold filled watch and chain warranted 20 years do not accept it. If entirely satisfactory pay express agent Our Special Price \$4.50 and express charges and it is yours. Our 20 Year Guarantee sent with each watch. Mention if you wish Ladies or Gents size. **DIAMOND JEWELRY CO., Dept. F 50, 225 Dearborn St., CHICAGO, ILL.**

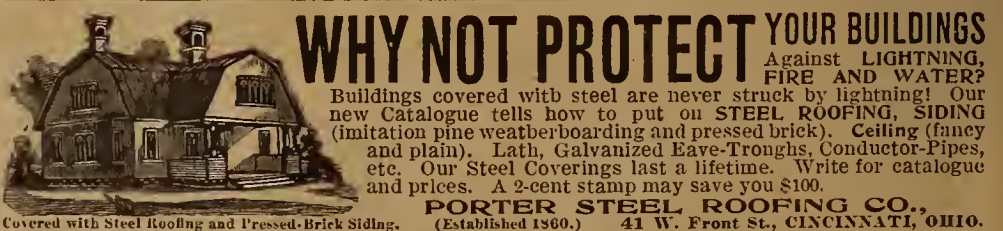

**WHY NOT PROTECT YOUR BUILDINGS** Against LIGHTNING, FIRE AND WATER?

Buildings covered with steel are never struck by lightning! Our new Catalogue tells how to put on **STEEL ROOFING, SIDING** (imitation pine weatherboarding and pressed brick). Ceiling (fancy and plain). Lath, Galvanized Eave-Troughs, Conductor-Pipes, etc. Our Steel Coverings last a lifetime. Write for catalogue and prices. A 2-cent stamp may save you \$100.

**PORTER STEEL ROOFING CO.,** (Established 1860.) 41 W. Front St., CINCINNATI, OHIO.

**FERTILIZERS—FROM FACTORY TO FARM**

WE SELL YOU DIRECT. NO AGENT'S PROFITS. NO SALESMAN'S EXPENSES.

**VALUABLE PREMIUMS GIVEN FREE.**

For premium list, prices, samples and book, write

**THE SCIENTIFIC FERTILIZER COMPANY, HERR'S ISLAND, PITTSBURG, PA.**



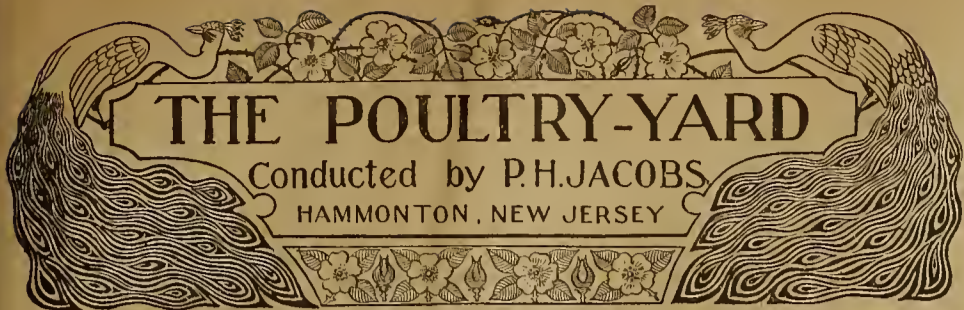

**POULTRY AS SOIL-IMPROVERS**

SOME poultrymen are favorable to the method of keeping poultry in small flocks, in confinement, with two yards to each flock, in the greater opportunities given for improving and using the land. Only one half of each acre will be occupied at the same time by the fowls, the other half being devoted to gardening, alternating the hens and the garden as occasion permits. The half acre in vegetables will produce as much as was formerly secured on an acre, and no manure need be bought or hauled, for not only will the hens (like sheep) scatter the droppings themselves, but they also accumulate at night a large quantity, which may be applied where it will be most serviceable. One great source of fertility to the land from the keeping of poultry, in addition to the droppings, is an enormous loss of food from the trampling of the fowls, the pickings from the trough, and the discarded amount due to fermentation, all of which serve as plant-food. Keeping fowls in yards, removing them frequently and turning under the manure, prevents the fowls from living in filth, and permits of an enormous production of crops. On a piece of light, sandy soil that has been considered almost barren, where a flock of thirty hens were kept for a year, was grown an enormous crop of potatoes, beans, cabbage and peas. The growth was excessively rank, and for three years after the same plot was more productive than any of equal space on the place. The food bought annually for a flock is equal to bringing a large quantity of fertilizer on the farm, and in passing through the body of the fowl it is reduced to a condition fitting it for immediate use by plants. The fresh earth absorbs and retains its valuable properties better than the droppings from the roost can be saved. That fruit, vegetables and poultry should be combined is a fact that will some day be admitted by all; but when the system is practised the free arrangement may be abolished, and the hen be used not only for producing eggs and poultry, but also for improving the soil, just as is now done in France, and as is done with sheep in England. The poultry of France keep up the fertility of the farms, yield large profits of eggs and meat, and increase the flocks, yet the flocks are small and no rauges are permitted. If it is possible in France it is possible here, and the time will yet come when no small gardens will be cultivated without a flock of hens as assistants instead of being considered enemies.

**EGGS AND THEIR COST**

It is not the cost of poultry and eggs that should be considered, but the number of eggs in proportion to cost. One can better afford to allow ten bushels of feed to hens that lay regularly than to feed one bushel to hens that do not lay. The profit a hen gives depends upon the prices obtained, but it is easy to discover which is the more profitable hen when we base the estimate upon what she daily produces, for no matter what the market value of the egg may be, it contains the same amount of nutrition and calls for the same service from the hen. If a large hen and a small hen eat the same amount of food, and are of the same age, the large hen has been more profitable, for the reason that, in addition to laying eggs equal in number to the other, she has also produced more meat in her carcass when she is killed and dressed. But the serviceable hen cannot be estimated by the number of eggs she lays. A hen may lay a greater weight of eggs than another and yet not come up in number to the others, and therefore, though not giving so large a profit (as eggs are sold by the dozen instead of

by weight), she is really more valuable than the profitable hen, so far as work done is concerned. We cannot estimate how much food is required for a hen for that reason, as some hens lay more eggs than others, some lay heavier eggs, and some do not lay at all, yet food is required for them. It is doubtful if any person can arrive at a knowledge of the actual average cost of an egg, but it is an easy matter to learn if the production of eggs is equivalent to the value of the food given. Something must be allowed, however, for the saving of the waste material used by the hens, as it really possesses no marketable value, but is picked up by the hens and converted into eggs. The value of manure is always an item of profit. The cost of the maintenance of the roosters is of course to be classed somewhere, while the males produce nothing except their bodies, yet they are necessities that must be paid for in some shape. It is an interesting problem and worth a few thoughts, as the value of eggs and their cost enter largely into the poultry account.

**EARLY AND LATE CHICKS**

Large chicks for roasting are always in demand, and they bring fairly good prices. They should weigh about two and one half pounds each, and are usually sold by the pair. The early chicks are known as "broilers," and should weigh about one and one half pounds each. The terms used are for designating the purposes for which they are intended, the "broilers" for broiling, and the "roasters" for roasting. If the cockerels become too large they will sell as cocks, the tall combs being detrimental to their sale in market. The late chicks should be confined and made fat before sending them to market, as such chicks do not command a high price unless they are attractive in appearance. Some seasons they are scarce, and bring twenty cents a pound, but usually a pair will sell for seventy-five cents, and as they are raised during the warm season the cost of production is less than for the early ones. It is admitted that the early chicks pay, and a comparison of the early and late chicks shows that the farmers and poultrymen can profitably hatch chickens every month in the year. The early chicks sell for from twenty to thirty cents a pound, but must not weigh over one and one half pounds each when sold, while the late chicks will sell for twenty cents, and may weigh as much as three pounds each. The demand is for early small chicks and late large ones. The prices received are about equal for the early and small chicks. The early chick can be produced during the winter when work is not pressing in other directions, while the late chick is capable of helping himself by a range over the farm, having warm weather in its favor. The early chick must be fed all that it receives, and requires careful watching. The eggs from which the chicks are hatched in winter cost more, and are not as fertile as in summer, but, on the other side, the late chick must contend with lice, hawks, cats, rats and other destroyers, while the early chick is protected under cover, in brooders or coops.

**GUINEAS ON FARMS**

When guineas are confined they seldom thrive, but when given the liberty of the fields they will hatch broods and rear them under difficulties that would be fatal to other kinds of poultry. The young ones feather very rapidly and do not need brooding after they are five weeks old unless the weather is somewhat cold. They are fed the same as young chicks, with the exception that they require finely chopped meat at least three times a week. As they

feather so rapidly it is necessary that they be fed often, as they will sometimes suddenly die when a few meals are missed, the feathering demanding a constant supply of nourishment. The question as to the profitableness of guineas admits of no denial. They may not be as profitable as hens when confined, but they can be raised with such little expense when they are at liberty as to return a large profit, both in eggs and in flesh. They are naturally wild, and hide to lay their eggs, but often betray themselves by the noise they make. By watching them going to the nests, or coming off, they are easily detected. The flesh is dark, but contains a delicateness of flavor that approaches to wild game. They are naturally noisy, and create an alarm on the approach of intruders. When guinea eggs are placed under hens, the best way of hatching is to add a few chicks to the number by putting hens' eggs in the nests a week after the guinea eggs are set, and the chicks will teach the young guineas to obey the hens. Guineas are seldom marketed, being used mostly at home.

**CHOLERA CURES**

There is no sure cure for cholera. The best remedy is a teaspoonful of liquid carbolic acid in half a gallon of water. A great many persons inquire for remedies for cholera without knowing what disease may exist in the flock. When they state they have "cholera" in the flock and "cannot get rid of it" they give the best evidence that there is no cholera, for it rids itself in a few days. The symptoms are great prostration, a nervous, anxious expression, intense thirst, and profuse diarrhea of greenish color. Most of the supposed cases of cholera are due to indigestion from excessive feeding.

**UTILIZE THE WEEDS**

All the weeds that are not poisonous may be fed. Geese are very fond of purslane, and there is nothing more acceptable to ducks than hogweed or ragweed. The common crab-grass may be thrown to the hens, and tufts of grass cut with a spade and laid in the yards will be carefully picked over by all classes of fowls. Some weeds may also be utilized by being cooked, first being chopped to pieces.

**LICE ON CHICKS**

As a rule lice on chicks generally come from adults. When chicks are raised in brooders, and the adult birds are kept separate, it is very rare to have vermin infest the chicks. When chicks are raised under hens, therefore, the safest plan is to free the hen from vermin before she is allowed to have a brood, then keep her away from the other members of the flock.

**INQUIRIES ANSWERED**

**Black Spanish.**—A. G., Fernandina, Fla., writes: "I have selected Black Spanish as the breed for this climate; am I correct?"  
 REPLY:—They will probably give as good results in Florida as any other breed; they cannot be excelled as layers.  
**Frozen Combs.**—E. U., Unity, Mich., writes: "Will any ill consequences result from the chickens having their combs frozen last winter? The combs are now healed."  
 REPLY:—If the combs have healed the fowls will remain thrifty, except that the injury on each may appear unsightly.  
**The Range.**—J. R., Hancock, Md., writes: "My hens have free range and are in good condition; would it be correct to feed them?"  
 REPLY:—If they come up at night with full crops they will need no assistance, but it would not be out of place to give a light feed in the evening.  
**Young Turkeys.**—Mrs. P. D., Curtis, Ill., writes: "Please state how to care for young turkeys. Mine are hardy until a week old, and then many of them die."  
 REPLY:—Feed them four times a day, giving stale bread dipped in milk, chopped onions and lettuce, millet-seed, pin-head oatmeal, and other foods as they advance in age. The loss may be due to dampness or the large body-lice.  
**Animal-meal.**—G. R. E., Raleigh, N. C., writes: "How much animal-meal should I feed to thirty hens, and how often?"  
 REPLY:—Much depends on how the fowls are kept and the quantity of food allowed. Animal-meal promotes laying and is an excellent addition to the ration. About two pounds for thirty fowls, once a day, with other foods, may be allowed.

**HENCH & DROMGOLD'S GRAIN FORCE FEED and Fertilizer Drill**

Positively the nearest, lightest and strongest grain drill on the market. Many points of superiority: it is geared from the centre. Quantity of grain and fertilizer can be changed while in operation without the use of gear wheels. Fully guaranteed. Positively accurate in quantity. Give one a trial and be convinced. Agents wanted. Circulars free. Address HENCH & DROMGOLD, Mir's, York, Pa.



**SWAN'S STANDARD ROOFING**  
 2 & 3 PLY.  
 TRADE MARK.  
 THE A. F. SWAN CO., 110 to 116 Nassau St., New York.

Can be applied by any one on steep or flat roofs.  
**LOW PRICE! DURABLE! FIREPROOF!**  
 If you are going to build, or have leaky shingle or tin roofs, SEND FOR SAMPLE AND CIRCULAR.

**\$14 Sewing Machine**  
 If You Want to SAVE MONEY and get the best machine at lowest wholesale price, now is your chance. Buy direct from factory, one profit. All attachments free. 30 days' free trial. WARRANTEED 20 YEARS.  
 \$40.00 Arlington for ..... \$14.00  
 \$50.00 Arlington for ..... \$17.00  
 \$65.00 Kenwood for ..... \$21.50  
 Other Machines at \$9.95, \$10.50, \$12.00  
 Illustrated catalogue and testimonials free. CASH BUYERS' UNION, 158-164 W. VanBuren St., B-7, Chicago, Ill.

**FIRE, WEATHER, and Lightning Proof**

Black, painted, or galvanized metal ROOFING and siding; (brick, rock or corrugated) Metal Ceilings and Side Walls in elegant designs. Write for Catalogue. The Penn Metal Ceiling and Roofing Co., Ltd., 23d & Hamilton Sts., Phila., Pa., or 24 Harcourt St., Boston, Mass.

**GEM FULL CIRCLE Baler**  
 Warranted the lightest, strongest, cheapest & fastest Full Circle Baler in the market. Made of wrought steel. Can be operated with one or two horses. Will bale 10 to 15 tons of hay a day. Write for description and prices. GEORGE ERTEL CO., QUINCY, ILL.

Soon Saves Its Cost. **A 12-Year Old Boy**  
 A Labor Saver. can do more and better work, either in the field or garden, with the **HAND CULTIVATOR** than three men can do with common hoes. Plows, hoes, cultivates—astride or between rows. 1/20 agent in your town send \$1.35 for sample delivered and terms to agents. Ulrich Mfg. Co., 43 River St., Rock Falls, Ill.

**ORCHARD PROFIT** depends upon working all the fruit into a salable product. Cider, for instance. If good, clear and pure it sells readily at a profit. The best is produced by a **HYDRAULIC CIDER PRESS**. Made in varying sizes; hand and power. Get our free catalogue before you buy. HYDRAULIC PRESS MFG. CO., 6 Main Street, Mt. Gilead, Ohio.

**FARMERS** Send for a large Catalogue of the celebrated "DeLoach" VARIABLE FRICTION FEED Saw-Mills, Shingle-Mills, Planers, Hay-Presses, Grinding-Mills, Water-Wheels, etc. Our Saw-Mill is warranted to cut over 2,000 feet of hoard lumber in ten hours with 4-horse power. Prices low, and we pay the freight. DELOACH MILL MANUFACTURING CO., 300 Highland Avenue, Atlanta, Georgia.

**SEE AND WONDER AUTOMATIC CREAM SEPARATOR**  
 Simple; easy to operate; durable; saves half the labor. Butter-making simplified. More and better butter. Farmers' and Agents' Gold-Mine. Price \$2.50; worth \$100. Send stamp for particulars. Agents wanted. Automatic Cream Separator Co., Quincy, Ill.

**NO DIRT LEFT** in clothes washed with the "BUSY BEE WASHER" 100 pieces in one hour and no hard work done. That is the record. AGENTS WANTED. Exclusive sale. Write for terms, Lake Erie Mfg. Co., 116 E. 13 St., Erie, Pa.

**SAVE THE MONEY** you are spending on repairs and buy new wheels. It is cheaper and in every way better. We sell 4 Buggy Wheels, 7-8 in. Steel Tire for \$7.50 4 Carriage Wheels, 1 in. Steel Tire for \$8.00 Other wheels for other purposes equally low priced. Measuring directions free. Write for price list No. 31. WILMINGTON WHEEL CO., Wilmington, Del.

**LEE'S LICE KILLER** CLEANS OUT THE LICE and mites on poultry and dogs without handling fowls or animals. Painted or sprinkled on roosts, bedding or rubbing posts, the Lice Killer does the rest. We prove it with FREE SAMPLE. Our new catalogue of Stock and Poultry Supplies free upon request. GEO. H. LEE CO. Omaha, Neb., or 68 Murray St., New York

**FENCE! STRONGEST MADE.** Built strong. Chicken-tight. Sold to the Farmer at Wholesale Prices. Fully Warranted. Catalogue Free. COILED SPRING FENCE CO. Box 18. Winchester, Indiana, U. S. A.

**DON'T SET HENS THE SAME OLD WAY**  
 The Nat'l Hen Incubator beats old plan 3 to 1. Little in price, but big money-maker. Agts. wanted. Send for cat. telling how to get one free. Natural Hen Incubator Co., B 22, Columbus, Neb. A. Edwards writes, "Would not take \$100 for N. H. I. Plan."  
**DEATH to LICE** on hens & chickens. 64-p. Book Free. D. J. Lambert, Box 303, Apponaug, R.I.



## QUERIES

READ THIS NOTICE

Questions from regular subscribers of FARM AND FIRESIDE relating to matters of general interest will be answered in these columns free of charge. Querists desiring immediate replies, or asking information upon matters of personal interest only, should inclose stamps for return postage. The full name and post-office address of the inquirer should accompany each query, in order that we may answer by mail if necessary. Queries must be received at least two WEEKS before the date of the issue in which the answer is expected. Queries should not be written on paper containing matters of business, and should be written on one side of the paper only.

**Cement for China and Glass.**—A. S. K., Beauford, Minn. A good cement for china, glass, metal, etc., is made by adding plaster of Paris to a strong solution of alum until the mixture is of the consistency of cream.

**Keeping Hams.**—D. H., Alta, Ill. Wrap the hams in coarse brown paper and pack them in clean hard-wood ashes in boxes or barrels. Keep the boxes in a dry place. If well cured and properly smoked hams can be kept sweet in this way without danger of insects or mold.

**Concrete Walls.**—W. T. H., Grand Rapids, Mich. Make the walls twelve or fourteen inches thick. Begin below the frost-line. Erect scantlings as a guide for the boards forming the mold of the walls. To three parts of clean, sharp sand perfectly free from loam or clay add one part of Portland cement. Mix thoroughly, add water, and make a thin mortar of the sand and cement. Pour it into the mold, and bed broken stones in it, being careful not to have them touch the sides of the mold. In a day or two, after the concrete has "set" or hardened, raise the boards and build another layer. Ram the concrete solid in the mold. Do not make too much mortar at a time.

**Preserving Butter—Whitewash.**—J. H. G., Beulahville, Va., asks how to keep butter through the summer, and how to make whitewash that will last.

REPLY:—Good butter can be kept perfectly sweet in cold storage, but few have such facility. June butter can be kept for winter use by preserving it in brine in granular form as follows: Stop churning when the butter comes in small granules the size of wheat-grains. Add cold water equal in quantity to the cream in the churn. A little salt added will facilitate the separation of the buttermilk from the butter. Draw off the buttermilk and water. Pour in more cold water slightly salted, turn the churn a few times, and draw the water off. The third washing may be with brine. After the brine is drawn off let the butter drain awhile. For a package use an oak cask previously cleansed and scalded out with brine. Put a layer of salt in the bottom with a muslin cloth over it. Fill up the cask with the granular butter. Put a cloth over it, and then a layer of salt. Head up the cask, and drive down the hoops tight. Bore a small hole in the head of the cask, and through it pour in all the brine the cask will hold. Store it in a cool place. Occasionally add brine until it will take no more, then plug the hole tight, and let the cask remain in a cool place until you want to sell the butter. Then take it out and pack it in the ordinary tubs for market.—To make good whitewash, take fresh-burned lime, one half bushel; slake it in hot rain-water, keeping it covered closely during the process. To this add one peck of salt dissolved in soft water and five gallons more of hot water, and stir the mixture thoroughly. Cover it up and let it stand a few days. Add sufficient bluing to give it the tint desired, and apply hot. The secret of making whitewash that will stick is to have good lime, properly slaked, well mixed with salt, and applied hot. In place of the salt a half pound of glue previously dissolved in hot water may be used.

## VETERINARY

CONDUCTED BY DR. H. J. DETMERS

To regular subscribers of the FARM AND FIRESIDE answers will be given through these columns free of charge. Where an immediate reply by mail is desired the applicant should inclose a fee of one dollar, otherwise no attention will be paid to such a request. Inquiries should always contain the writer's full address. Queries must be received at least two WEEKS before the date of the issue in which the answer is expected. Veterinary queries should be sent directly to DR. H. J. DETMERS, 1315 Neil Avenue, Columbus, Ohio.

NOTE.—Parties who desire an answer to their inquiries in this column must give their name and address, not necessarily for publication, but for other good reasons. Anonymous inquiries are not answered.

**Swine-plague.**—B. H., Woodland, Wash. What you describe is swine-plague, or so-called bog-choleera.

**Sore Throat.**—W. H. J., Klitchings Mills, S. C. According to your description, it is not improbable that your dog had in his mouth or swallowed some corrosive substance, but whether it was lye, corrosive sublimate (not calomel), carbolic acid or something else cannot be learned from your information. Continue your treatment if the dog has not yet recovered when this reaches you.

**A Diseased Sheep-buck.**—E. L. T., Farmington, Pa. Such a swelling beneath the lower jaw of your buck as you describe is usually one of the last and fatal symptoms of general dropsy and debility in sheep, usually brought on by worm diseases, particularly by liver-flukes (Distomum hepaticum).

**Flies on Cattle.**—S. L. H., Berea, S. C. If your cows are in pasture you can keep the flies off by covering each cow with a light and thin blanket, and if the same are kept in a stable, by darkening the latter and by keeping the same and its surroundings as clean as possible. Light and thin blankets are extensively used in Holland.

**Brain Disease.**—T. M. E., Atkinson, Neb. The symptoms of your calf, as you describe them, are those of a severe affection of the brain, but similar symptoms also occur in rabies in cattle, a disease which at present appears to be rampant in the United States; but so far I have been unable to learn that the authorities have taken any measures anywhere to prevent its further spreading.

**Diseased Sheep.**—E. F., Gurleyville, Conn. The symptoms of the diseased sheep, as you describe them, are either caused by lung-worms (Strongylus filaria) in the ramifications of the bronchi, or by so-called grubs (the larvae of a fly, Oestrus ovis) in the nasal cavities, the frontal and maxillary sinuses and the ethmoid bones. The sheep will probably be dead when this reaches you.

**A Crippled Horse.**—J. H., Miller, S. D. Unless you give me a fair description of your case, instead of reciting the contradictory opinions of yourself and others, and stick to facts bearing upon the case, it is impossible to make a diagnosis. If it is ring-bone you had no business of sticking your knife into it, and by doing so you may possibly have opened the joint and made the horse a worthless cripple.

**Nymphomania.**—J. H. R., New Brighton, Pa. Your cow, it seems, is suffering from nymphomania, a disease usually caused by a diseased condition of the ovaries. If the ovaries are the only organs that are diseased—the disease, in most cases at least, is tuberculosis—such a cow may be made a good beef animal if the ovaries are removed, especially if it is done by Charlier's method, through the vagina.

**Chronic Dog-distemper.**—C. M., Corsicana, Mo. If your young dog had distemper three months ago, and has not yet recovered, has nervous symptoms, is short-winded and is without appetite, the prospect of ultimate recovery is a very slim one. It may be possible to keep the animal alive by careful treatment, or even to effect some improvement, but the same will never be a dog worth having. It will give more satisfaction to get a new dog.

**A Severe and Chronic Respiratory Disorder.**—S. S., China, La. What you describe may be nothing but a severe case of chronic distemper, but possibly it may be something much more dangerous; at any rate, the admixture of blood in the nasal discharges, now disappeared, but present some time ago, must cause some suspicion. I therefore have to advise you to have the horse examined by a competent veterinarian at your earliest convenience.

**Lice on Cattle.**—E. C., Farrham, N. J. First give your cow a thorough wash with soap and water, then wash her all over with a four-per-cent solution of creolin in water; this done, drive her out to pasture, or if you have to keep her in the stable, do the washing outdoors, and while the cow is outside have the stall or stable thoroughly cleaned, so that neither lice nor nits can hide anywhere, and then repeat the washings and cleaning in about five days.

**Esophagocele.**—S. A. C., Medford, Okla. What you describe is evidently a case of esophagocele or of a diverticle in the esophagus, or gullet. The esophagus, or gullet, is composed of two distinct membranes, of which the inner one, a mucous membrane, is very elastic, and the external one, a muscular coat, or the muscularis, is much less yielding. If it happens that the external coat, the muscularis, ruptures from one cause or another, the inner coat, or the mucosa, being very elastic and yielding, is forced through the rent, bulges out and forms a sack, which is gradually increasing in size by the pressure of the food accumulating in that sack. This is what is called esophagocele or an esophageal hernia. The remedy consists in a surgical operation skillfully performed.

**Wind-broken.**—S. McC., Waterbury, Conn. Although I do not doubt that your mare, now wind-broken or affected with heaves, has been an engine-horse and has been overworked, I doubt very much that her chronic difficulty of breathing has been caused by overexertion, although I will not deny the possibility that such might have been the case, for it is far more probable that the ailment, heaves, has been caused by eating too much dusty hay. Heaves, or broken wind, as has been often explained in these columns, must be defined as a chronic, feverless and incurable difficulty of breathing. Your mare can never again be made a good roadster. One who buys a condemned horse always must expect to get a defective animal or an animal suffering from an incurable ailment. For further information please consult the numerous answers recently given in these columns under the heading "Heaves."

**Paralyzed in Hind Quarters.**—F. K., Civil Bend, Mo. Since your cow became paralyzed just about three weeks after calving, it is not at all improbable that she was in heat at that time, and that other cattle jumped on her in an awkward manner and injured either her loins or her sacrum, or even caused a fracture in the posterior portion of the spinal column. A close examination will soon reveal the true condition.

**Skin Disease of Lambs—Heaves.**—A. P., Progress, W. Va. The skin disease of your lambs is probably herpes tonsurans, or so-called ringworm. Shear away the wool from the affected parts, and then paint them once a day by means of a small brush or pencil with some tincture of iodine, but see to it that none of the tincture gets into the eyes.—Your mare very likely has so-called heaves. About this please consult the numerous answers recently given under the heading "Heaves" in these columns.

**Foreign-body Pneumonia.**—C. R. G., Osage City, Kan. Your mare, it seems, first had colic, then was dosed with various medicines, and some of these medicines were poured down the trachea into the lungs. In consequence gangrenous (foreign-body) pneumonia developed when the colic began to disappear, and it was the pneumonia that caused the bleeding from the nose and the death of the animal. Still, your horse is not the only one that was killed in that way. Such or similar cases happen every day, and more horses suffering from colic are killed by medication than directly by the attack of colic itself. A horse should never be drenched with fluid medicine if the same is in distress, or the respiration considerably accelerated.

**A Swelling on the Head of a Calf.**—M. Q., Vernon, Ill. Many different kinds of swellings produced by widely differing causes may be met with, consequently the simple information of the appearance of a swelling or lump, sometimes increasing and sometimes decreasing, on the side of the head of your calf does not enable me to decide what the nature and the causes of the swelling may be. I regard it as not at all impossible that there is no swelling at all, and that what you call a swelling is nothing more nor less than an accumulation of food between the cheek and the molars. This supposition at least would explain the alternate increase and decrease of the swelling. Parties sending inquiries should not forget that a diagnosis is not possible unless a good description based upon a close examination and careful observation is given.

**Perhaps Mild Attacks of Vertigo.**—I. S., Wallaceville, Mich. What you describe are either slight attacks of vertigo, or else some part of the harness, perhaps the collar, is ill-fitting, presses upon a vein, most likely the jugularis, and thus causes a temporary congestion to the brain, or at any rate interferes with the regular circulation of the blood. If, on a close examination, it should be found that an ill-fitting part of the harness constitutes the primary cause the remedy is easily applied, while vertigo must be looked upon as an incurable ailment, unless it be that the cause can be found and can be removed, which is seldom the case. Sometimes attacks of vertigo can be avoided if the animal subject to them is never bitted up immediately after a heavy meal, but is always given considerable time—from one to two hours—for digestion before put to work. There is no blind-stagger in your case.

**Herpes Tonsurans on a Dog.**—H. L. B., Brockway, Oreg. What you describe appears to be herpes tonsurans, or so-called ringworm. Since your dog, a collie, is a long-haired one, and the warm season of the year at hand, it may be advisable first to shear the animal, and then you will undoubtedly succeed in effecting a cure if you apply to each one of the diseased spots, perhaps with a small brush or pencil, some tincture of iodine. It will probably be necessary to repeat the application a few times, say about two days apart. If the dog should show a tendency to lick the diseased spots after the tincture has been applied, it will be advisable to muzzle him until the spots that can be reached with the tongue are dry again. To make the treatment successful it will be necessary to thoroughly clean and disinfect the sleeping-place of the dog each time the tincture is applied, for if this is neglected a reinfection is apt to take place.

**Died within Twenty-four Hours.**—A. F. F., Dyer, N. C. The mare surely did not die of colic, and there is no such thing as "chest-colic." Whether it was the bleeding from the nose that caused her death, or whether the bleeding was only a minor symptom or complication of the disease, does not proceed from your communication, because you only say that the bleeding continued until she (the mare) was dead; but you do not indicate how much blood was lost, and did not ascertain where the bleeding came from when the mare was cut open. I will ask you three questions, which you may be able to answer; and if you are, we may yet be able to arrive at a reliable diagnosis. First, Did the mare whinny or neigh while she was sick; and if she did, was there any peculiarity in her voice; and if so, what was it? Second, What was found in her stomach? Third, What was the color of her blood when the post-mortem examination was made, and was it coagulated or not?



**Ayer's Pills**  
Sick headache. Food doesn't digest well, appetite poor, bowels constipated, tongue coated. It's your liver! Ayer's Pills are liver pills, easy and safe. They cure dyspepsia, biliousness. 25c. All Druggists.

Want your mustache or beard a beautiful brown or rich black? Then use  
**BUCKINGHAM'S DYE** for the Whiskers  
50 CTS. OF DRUGGISTS, OR R. P. HALL & CO., NASHUA, N. H.

## KENDALL'S SPAVIN CURE



The old reliable remedy for Spavins, Ringbones, Splints, Curbs and all forms of Lameness. It cures without a blister because it does not blister. Price \$1. Six for \$5. As a liniment for family use it has no equal. Ask your druggist for Kendall's Spavin Cure, also "A Treatise on the Horse," the book free, or address  
DR. E. J. KENDALL CO., Enosburg Falls, Vt.

## We Save You Money

on every rod of fencing you buy from us. Why? Because we sell you the  
**ADVANCE FENCE**

Direct from the Factory at Wholesale. Dealers cannot buy it any cheaper than you can. We save you the middle man's profit. You get a good fence at a low price. Beats a hand fence machine all to pieces. No loose ends to unravel. All closely interwoven—cross wires cannot slip. Write at once for our free circulars and special discounts.  
Advance Fence Co. 116 Old St., Peoria, Ill.

## "Goshen" Tanks

Represent Honest Tank Value...

and these are the reasons why: They are made of the best heavy galvanized steel; they simply cannot warp, swell or fall to pieces from drying out; heavy iron bound edges protect them from bending or denting.

**ANTI-SEPTIC**  
there is no place for disease germs in these tanks. Pure water makes good milk and butter; prevents many diseases, bog cholera, etc. Don't buy until you get our 48 page catalogue, sent FREE.  
Kelly Foundry and Machine Co. 12 Purd St., Goshen, Ind.

## SAVE IT ALL.

The butter makers' success depends upon clean skimming—getting all the cream out of the milk, in the quickest, cheapest way. Our improved patent  
**AQUATIC CREAM SEPARATOR**  
does this. Beats the best creamery made and costs less than half as much, capacity considered. Takes all the cream out of milk in two hours' time. For 1 to 40 cows. Prices \$5. to \$11. Write for FREE Catalogue and testimonials. AGENTS WANTED.  
Aquatic Cream Sep' for Co., 125 Factory Sq., Watertown, N. Y.

## A GOOD WINDMILL

LASTS A LIFETIME  
Don't buy a poor one when you can buy the  
**IMPERIAL**  
with patent internal gear and malleable iron frame. Write  
MAST, FOOS & CO.,  
24 River St., Springfield, Ohio

## PAGE

Watered Stock, Common or Preferred, don't go through Page Fences. See! It's no Trust.

PAGE WOVEN WIRE FENCE CO., Adrian, Mich.

We are the largest manufacturers of Steel Wheels and Truck Wagons in the World. Write for Catalogue. Havana (Ill.) Metal Wheel Co.

**BEE KEEPERS**  
Send for Free Sample Copy of GLEANINGS IN BEE CULTURE handsome semi-monthly magazine. All about profitable Bee-Keeping. Book on Bee Culture & Bee supplies free if you mention this paper.  
The A. I. Root Co. Medina, O.

**GINSENG** We are Headquarters for Seed & Plants.  
Valuable book about it, telling how to grow thousands of dollars worth, what used for and who is growing it. Sent for 10c  
AMERICAN GINSENG GARDENS, ROSE HILL, New York.

Make Driving Pleasant! THAT LITTLE HOOK supports lines on horse's hips. Sent 20c. for samples or write The Perfect Rein Guide, Three Oaks, Mich.

**Binder Twine**  
FARMERS WANTED AS AGENTS  
AUGUST POST,  
Moulton, Iowa.



THE GRANGE

Conducted by MRS. MARY E. LEE, New Plymouth, Ohio

"The wicked wit he dug a pit,  
He dug it for his brother;  
And for his sin he did fall in  
The pit he dug for t'other."

THE stockholders in the wire trust realize the full force of the above ancient version of one of David's Psalms. So long as they were able to ensnare consumers in their pit their cup of happiness was full; but when they themselves fell in the pit of their own digging their howls rent the heavens. This liability of the stockholders to become engulfed in the pit of their own digging will make them more cautious about entering into a trust, and render the work of the promoter less easy.

\*\*\*

We are in receipt of a bright paper, the Sandusky, Ohio, "Register," containing a Grange department, edited by Mrs. Mary Anderson. We make the following extract, which indicates the high plane upon which Mrs. Anderson places her paper:

"Would that more would devote their time to self-culture and make of themselves all that God intended they should be. It rests with ourselves whether we be narrow, gossipy, jealous-minded or broad and noble, striving each day by God's help to lift ourselves above the petty annoyances of every day to a higher plane, where we may get a broad, extended view and understand better what life means and what we are here for."

\*\*\*

"Build the more stately mansions, O my soul,  
As the swift seasons roll!  
Leave thy low-vaulted past!  
Let each new temple, nobler than the last,  
Shut thee from heaven with a dome more vast,  
Till thou at length art free,  
Leaving thine outgrown shell by life's unresting sea."

—From "The Chambered Nautilus," by Oliver Wendell Holmes.

\*\*\*

A reader asks where the books on nature-studies mentioned in the April 15th issue may be gotten. She apologizes for doing so. We are only too glad to answer just such questions, knowing that some little life will be made brighter and sweeter. When planning to make a party or get presents for the little one's birthday, why not get instead, Hawthorne's "Wonder Book," Grimm's "Fairy Tales," "Alice in Wonderland," or some one of these old books that will prove a source of inspiration and joy for many a day?

2

JUNE TOPIC—CO-OPERATION IN MANUFACTURE OF FARM PRODUCTS OR FARM SUPPLIES

QUESTION.—In what way can business co-operation in the manufacture of supplies now purchased, or of products sold, be made available to members of the grange?

This feature of business co-operation in the grange has been discussed less than any other feature of the general topic, and yet it is prolific in possibilities. We do not advocate the establishment of extensive manufacturing plants, conducting business on a large scale, for the reason that such ventures require great capital and able financial management attended with great risk. In fact, we believe the instances are very rare where extensive co-operative business enterprises under the direction of the grange have been reported as successful, and if we except mutual fire and life insurance such instances are rare under any co-operative management. Such matters seem specially adapted to local application where expenses can be controlled and the condition of the business constantly known by all co-operating in it. In this manner creameries, cheese-factories, condensed-milk factories, canning-establishments, sugar-beet factories, fruit-evaporators and pickle-factories are frequently of great benefit to the producers, and their establishment has been the result in thousands of in-

stances of agitation of the subject in the grange. The capital to build and equip such factories will generally be forthcoming from some source when the farmers have co-operated in an agreement to provide the material for its operation. Many country towns would be greatly benefited, and the prosperity of the farmers would be greatly promoted by the establishment of something of this kind which would distribute a regular monthly income among the patrons.

In the matter of supplies there is less opportunity for co-operation in manufacture, but there is one very important opportunity that should not be neglected. We refer to the purchase of chemicals and mixing them upon the farm in place of buying ready-mixed fertilizers. The frequent assertion that it requires costly machinery and deep scientific knowledge to do this has been effectually dispelled. The ordinary farmer can make a liberal saving by purchasing chemicals and manufacturing his own fertilizers, and should co-operate with the members of his grange in this matter. The experiment station in any state will furnish specific directions for it.

We offer no apology for suggesting the intensely practical subjects of this quarter, for in some granges there is a tendency to confine the discussions to literary and sentimental topics to the exclusion of practical topics bearing upon farm economy. We think this fact a sufficient reason for devoting at least one number of the Bulletin to such topics as we have here considered, and expect beneficial results will follow their consideration in the subordinate granges of the country. We must secure material as well as mental and fraternal advantages from our connection with this grand order, although we expect the latter to far outstrip the former in the advantages derived through association in the grange.—National Quarterly Bulletin.

THIRSTING FOR KNOWLEDGE

A reader in Wyoming writes that she is a poor countrywoman thirsting for knowledge, but can see no way of gratifying her ambition because of lack of funds for the purchase of books. She says she takes the San Francisco "Examiner" and three very good magazines. She asks, "What advice would you give for self-education without money, as that is the drawback?"

When a child I asked my mother why she read her Bible so often. It seemed to me she ought to know it thoroughly after so many years' devotion to it. "Because new beauties appear every time I read it. It is a fountain that never goes dry," she replied. I did not understand it then. I do now. An old book is like a tried friend—it gives all, asking no recompense save our faithful devotion.

In the hurly-burly of life we are losing the faculty of thought. We rush, from one printed page to another, seeking entertainment, excitement, relief from ourselves. We cannot be alone. We have not the courage to withdraw to the mountains and meditate in silence. We pity our ancestors for their enforced isolation, the narrowness of their lives. We cannot understand the contentment that their isolation from humanity and their constant intercourse with Nature gave. They thought; we read. They worshipped; we scoff. In their Bible, "Pilgrim's Progress," Burns, Shakespeare, and other choice spirits give us the surcease from worry they gave others? Because we are not devoted to them. Because we will not be sincere and true to them they refuse their consolation to us.

I believe herein lies the cause of much discontent. We read too much; we digest too little. A great reader is usually a bore. He is pedantic. He talks about books and pictures and people. He doesn't talk books. He has not entered into the inner sanctuary of thought. A few books, of the best kind, well read, will bring more consolation and true knowledge than a library of a thousand volumes hastily

read over. It is the one who thoroughly masters one point that we fear in a debate. The one who rushes from one thing to another, depending on the quantity of points, not the force of one, is of no consequence. He is not resourceful. Let us read less and think more. Herein lies the secret of true education, the power of thought. I would suggest that our Wyoming friend, and thousands of others who are similarly situated, drop some of the magazines, and use the money thus saved for the purchase of books. Not the new ones that are pouring from the press, but the standard works that have comforted and cheered thousands of hearts, and that will cheer thousands more. These can be gotten very cheaply. Confine your thoughts to one story or poem or play. Read it, study it, till it brings a lesson to you. Be assured that if it had no message it would not have lived till this day. The law of the survival of the fittest is as potent in the literary world as in the physical. If you think of trying to read Shakespeare, try first to master the story. Turn the sentences into prose. Study it as a student studies his liad. It may take a good deal of hard study to overcome the seeming difficulties, but it will richly compensate one for the trouble. Write out the thoughts that arise in your mind. In time you will learn to be fastidious in the choice of words. You will search your dictionary as eagerly for words that will express your exact shade of meaning as the worker in embroidery selects her colors. In this study Sherman's "Analytics of Literature," published by the Gunns, costing \$1.25, will be of great help.

All science, literature, art, philosophy is but the interpretation of Nature's laws. Get close to the heart of Nature. Always carry a pencil with you. Questions will arise in your mind. Write them down. Some time you will be in reach of a library. Go to an encyclopedia and read up on the questions. The answer will encourage you to ask other questions. Cultivate your curiosity. An inquiring mind is a fertile one, wherein will grow knowledge and peace and happiness. If you have Lowell's poems, study "The Vision of Sir Launfal." Tennyson's "Search for the Holy Grail" is another version of the same legend. "A Glance Behind the Curtain" and "The Present Crisis" are the other important poems by Lowell. Nearly every one has Longfellow. Study carefully "Evangeline" and "Hiawatha." Commit to memory the parts of "The Bridge" that appeal to you; also "The Day is Done." Do not depend on remembering the facts only. Get the settings as well. The reason certain passages appeal to you is because they correspond to your own inner experiences, but are clothed in more fitting language than you could give them. Meditate upon these things till new beauties are revealed. Whatsoever revelation you are prepared to receive, you will receive.

I hope readers will determine to make use of the resources at hand, and not fret because they are so few. The choicest minds the world has produced confined themselves to a few writers. They read other books for recreation, but for knowledge and insight they were indebted to a few choice spirits. But only those books that are recommended by persons of known judgment. Time is too precious to waste on inferior writers. Then if you have a hundred books, or only a dozen, each one will fill a niche in your mental life. Each will speak to you as an old and chosen friend. After a time you will find yourself shrinking from new candidates for favor, as you shrink from a stranger, while the old, if well chosen, and studied, will ever lead you into new channels of thought, ever fit you for receiving new revelations.

It is unwise to spend all our money on current magazines. Much of their contents are ephemeral, written to while away an idle hour, not to instruct and render every hour a blessing. Commit many choice selections to memory, and as you are about your work they will unconsciously rise to your lips. We will give choice quotations whenever practicable. Memorize them, and in a short time you will have a fund of rich gems.

Here's economy: Less ice; less salt; one quart aerated into three pints. Lightning Freezer.

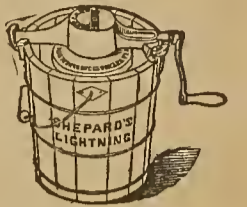

A beautiful child's book in three colors free. Address North Bros. Mfg. Co., Philadelphia, Pa.

TERRIFF'S PERFECT WASHER

SENT ON TRIAL at wholesale price. If not satisfactory money will be refunded. **WASH** under a POSITIVE GUARANTEE to wash as clean as can be done on the washboard, even to the wrist- and neckbands of the most soiled shirt, and with far greater ease. Does not wear out the clothes. Economizes soap, labor and time. **AGENTS WANTED.** Exclusive territory given. Big money made. For terms and prices Address, Portland Mfg. Co. Box 27, Portland, Mich.



WHEEL CHAIRS

ALL KINDS \*\*\*\*\* For Invalids and Cripples Built on new and practical methods at moderate prices. Full Particulars on Application. **RECLINING CHAIRS** For LIBRARY or SICK-ROOM Every known position for comfort. Write us for Free Illustrated Catalogue. Mention this paper. 152 Sixth Street STEVENS CHAIR CO. Pittsburg, Pa.

**SAVES YOUR BACK.** Carpet laying—hardest and most disagreeable work of house cleaning time—is made the easiest by the **Positive Carpet Stretcher and Tacker.** Works perfectly, stretching the carpet to its place, feeding the tacks and driving them home to stay. Works on wheels; gets into all corners. Price only \$1.75. Circulars and special terms free. Deposit Pearl Button Co., Dept. F, Deposit, N. Y. Big Money for agents. Write today

48 LBS. OF COFFEE FREE

to your friends; and either an elegant 56-piece Tea Set or a 62-piece Dinner Set, your choice, FREE for yourself, if you will assist in promoting our business. No canvassing necessary. Write us a letter or postal card stating you will distribute the Coffee among your friends. We pay freight on Coffee to any R. R. Station within 500 miles of N. Y. Our offer is a grand one. You should accept it at once. Address **WARNER & CO., Box 2431, NEW YORK.**

**WE SHIP ON BICYCLE DEPOSIT** \$11.75 Buys a Bicycle Complete, Unguaranteed. \$16.50 Buys an Up-to-Date Model. Fully guaranteed. \$22.50 Buys a Full Racing Model. Shop-worn Bicycles from \$10 up. 24 Hand Wheels from \$5.00 up. We want Agents Everywhere. 64 page catalogues of bicycle parts and repairs FREE. Write for catalogue and see how you can get a BICYCLE FREE by helping us advertise. Address, Dept. A-3, **VICTOR MANUFACTURING CO., 161-167 PLYMOUTH PL., CHICAGO, ILL.**

**GOOD WHEELS** MAKE A GOOD WAGON. Unless a wagon has good wheels it is useless. **THE ELECTRIC STEEL WHEELS** are good wheels and they make a wagon last indefinitely. They are made high or low, any width of tire, to fit any skien. They can't get loose, rot or break down. They last always. Catalog free. Electric Wheel Co., Box 96, Quincy, Ills.

**COLONY IN REPUBLIC OF COLOMBIA, SOUTH AMERICA** ON THE MAGDALENA RIVER. 300,000 Acres, \$5 Per Acre, Payable in 5 Years. A great industrial colony; climate and soil same as Southern California; oranges, grapes, coconuts, India rubber, vanilla beans, and all hard woods; such as ebony, mahogany, lignum-vite, laurel, walnut, etc. Send for circular. **MAGDALENA RIVER COLONIZATION COMPANY, 71 Broadway, N. Y.**

**\$5 BICYCLES CHEAPER THAN EVER** from the OLD RELIABLE CO. Great Special Sale. Nearly 8000 Bicycles, every one a BARGAIN. Must be sold. All makes, 2nd h'ds, \$5 and up. Late Models new \$11.50 and up. Shipped anywhere on approval. A few more good agents wanted. Big Money. Write to-day for big list and special offers never before approached. **BROWN-LEE CO. Dept. (J) Chicago, U.S.A.**

**BEST CALICO 3/8c. Yard** gingham, 3/8c; seamless socks, 3/8c; blueing, 1c; soap, 1c; stove-polish, 2c; gold ring, 1c; jeans, yard, 9/16c; spectacles, 3c; men's jeans, 49c; boy's pants, 14c; men's \$2.25 shoes, 98c; men's shirts, 15c; dippers, 2c; knives, 3c; shoe-blacking, 1c; men's wool socks, 9/16c; box tacks, 1c; men's fine suits, \$3.95; rice, per pound, 3c; oatmeal, 2 1/2c; smoking-tobacco, 3/8c. Send for price-list. **C. A. WILLARD CO., Chicago, Illinois.**

**WANTED** Reliable men or women to sell our goods to the consumer in communities from 1,000 to 10,000 population; permanent employment at good pay. Address **THE GREAT EASTERN COFFEE & TEA CO., 801 South 10th Street, St. Louis, Mo.**





## THE CURFEW BELL

By Frances Bennett Callaway

How little parents sometimes know of the whereabouts of their children on the street is shown by this story of Miss Greenwood as told her by a detective. The detective, who was employed in New York by the Society for the Prevention of Cruelty to Children, entered a saloon on Broadway where the air was so vile that for a few moments he was obliged to lean against a glass partition at the back of the saloon to recover from a feeling of faintness. While there he was compelled to listen to language so foul and so impure as to make him shudder.

Entering into the room back of the glass partition the detective found fifty little boys engaged in various games, and all of them gambling. So skilful had these young gamblers become that this detective, who seated himself at one of the tables, was very soon relieved of five dollars.

As the boys left this gambling-den in little groups the detective followed them, taking the street and number of their homes, and then returned to follow other companies. One boy was followed until seen to enter a luxurious home on Fifth avenue. Calling upon these parents the next day, the detective learned that their son had asked to study his lessons with the next neighbor's boy. From the next neighbor's house the two had slipped easily enough over to Broadway and spent the evening in gambling.

In country villages, where there are seldom night-watchmen and no humane or benevolent societies to throw protection around neglected children, the case is sometimes even worse than in our large cities.

Children of tender years, lacking in judgment and self-control, need such restraint thrown around them as will protect them until judgment is matured and character is in some measure developed. With this in mind parents, village trustees and even children's societies have resolved that the curfew-bell is a good thing, and this ordinance has now become a law in a number of our small cities and villages.

The bell is rung at eight o'clock on winter evenings, and at nine o'clock in the summer, when all children under fifteen are expected to return to their homes. The time is sometimes extended until nine o'clock on Saturday nights in the winter, and if children should sometimes be out a little after nine in the summer the offense would not be considered a serious one provided they were near their own homes. The intention is to keep the spirit rather than the strict letter of this law.

At the first offense the child is not arrested, but is simply taken home, where the curfew-bell and its uses are explained to the parents. If the parents admit they have no control over their child, then the child is punished at the second offense. If the parents claim they can control their child, and fail to do so, the parents are very justly fined or punished for the second offense.

Librarians say that as a result of the curfew-bell children are drawing more books from the libraries; business men express themselves as greatly satisfied, because their goods are no longer disturbed or used to furnish a game of foot-ball in the street; the postmaster is relieved to find that he can perform his duties in quietness and peace without stopping to put out a gang of young marauders by force; as for the children themselves, they are much more contented to go home when all have to obey the same rule. The village trustees who have tried the curfew-bell say they would not think of having the ordinance repealed.

One village comes to mind where the night-watchman, being a man of firmness but gentleness, is loved by the children, who gather in the street at night to hear the curfew as they would gather for some jolly, good game. They have counted the minutes at their play,

these little children—fifteen minutes, ten minutes, five minutes—and at the hour they are ready and waiting; at last the bell begins to swing and ring, and then such a twinkling dash of footsteps, such scampering and laughing as makes even the watchman himself laugh, and the people look for it as one of the sights of the town.



"In no other country," says Lyman Abbott, speaking of this land, "have parents so much of hope and so much of ambition for their children." For this very reason, that the children are the hope and glory of the land, they should in every town and village have the protection of this curfew-bell.

### PRUNES, FIGS AND DATES

Before berries come, and when the winter preserves are just about gone, the question of what to have for dessert often is a bothering one. Children always love the sweet dried fruits, and when they are properly prepared they are both nourishing and delicious. The prune particularly is a much-misunderstood fruit. How often do you find them sewed up with brown sugar, making a thin, watery juice, the prunes themselves being hard and tough and indigestible, when, if thoroughly cooked, they are entirely different. Try the following receipt, and see what a fine dish it makes. If you are able to have cream to pour over them as you serve they are rendered doubly tasty.

**STEWED PRUNES.**—Wash the fruit, and for each pound of fruit allow one pint of water and half a pound of A sugar. Boil the sugar and water together for ten minutes, then add the fruit, and simmer gently for about two hours, or until perfectly tender. Drain the syrup from the prunes, and put them in the dish in which you intend to serve them; then boil down the syrup until it becomes thick, pour over the prunes, let them stand until the next day, and serve cold.

Do you fancy something more elaborate? Try this:

**PRUNE JELLY.**—Take one pound of prunes and one half boxful of gelatin. Soak the prunes over night, and stew them until tender in the water in which they have soaked. Take out the stones, and sweeten to taste. Have the gelatin thoroughly dissolved in half a cupful of hot water, and add to the prunes while still hot. Then add the

juice of a lemon and half a cupful of any kind of chopped nuts; put in molds, and let it harden. This is particularly nice with cream.

It must be remembered that these fruits have a distinct value as laxative agents, and therefore are particularly desirable. Figs can also be very agreeably cooked.

**STEWED FIGS.**—Take half a pound of sugar, one pint of cold water and the grated rind of a lemon. When the sugar is dissolved add one pound of figs, and gently stew for about two hours. The figs will become tender and plump. When ready to remove from the fire add the juice of a large lemon and a wine-glassful of sherry wine. This latter may be omitted, but it gives a very pleasant flavor. Serve the figs cold and with or without cream.

**FIG PUDDING.**—This receipt is for a very fancy dessert, and may be served in individual molds or in one large one. Take half a cupful each of chopped figs and suet, two cupfuls of bread-crumbs, one cupful of milk, half a cupful of sugar and half a cupful of flour. Stir into the flour a teaspoonful of baking-powder. Roll the figs and suet in flour. When the bread-crumbs have soaked up the milk add the half cupful of sugar and the yolks of four eggs, and beat well. When well mixed add, stirring slowly all the time, figs, suet and flour, and lastly the whites of the four eggs beaten stiff. If you desire, half a cupful of chopped nuts can be stirred in also and the whole mixture turned into a pudding-dish. Allow room for it to swell, and steam for three hours. One or two preserved cherries look very pretty on top as you serve. It may be eaten hot or cold and with either hard or soft sauce or cream.

**STEWED FIGS.**—Soak the figs after separating them for several hours in cold water, then stew them until they are plump. Drain them from the liquid and pile them on a dish, and serve with whipped cream sweetened with sugar and flavored with vanilla or essence of almond.

As for dates, they are usually eaten in their natural state, or stoned and mashed into a paste with a little lemon-juice, and used to spread between sandwiches or as filling for cakes.

**STUFFED DATES.**—These may be prepared by stoning them and inserting in the place of the stone an almond, half an English walnut or pecan-nut, and rolling in confectioner's sugar.

When the winds have a nip to them, and the rolling dust fills our nostrils and throats, it is well to have in the house a simple candy to ward off sore throats and hoarseness.

**HOARHOUD DROPS.**—Procure from the druggist a package of hoarhound herb, and soak about a teaspoonful in a little warm water. In about five minutes this makes enough flavor for three cupfuls of sugar. Strain the hoarhound-water carefully, and add enough water to make one and one half cupfuls. Pour this on three cupfuls of sugar, add half a teaspoonful of cream of tartar, and stir until dissolved. Boil until it is brittle when dropped into cold water. Pour in buttered pans and mark into squares. This will keep fresh and crisp for some weeks if protected from the air. **NANNIE MOORE.**

### A PLEASANT SEWING-ROOM

A sewing-room should be as bright and cheery as ingenuity can devise. One of my friends has a delightful one with blue and white furnishings which is as pretty as a picture and as convenient as one can imagine.

Matting is preferable to carpets or art squares, as it is more easily kept free from dust; and such pretty patterns are to be had at the present time that they are indeed objects of beauty. If one does not like matting for the sewing-room, a good piece of denim will make an admirable substitute. You can form no idea of the real beauty of a denim carpet if you have never seen one. Before being put down the seams are sewed close to the edge, carpet-paper is laid upon the floor, and the denim, being stretched over it, is tacked as any other carpet would be. It wears well and does not absorb dust—if one may be allowed the expression.

If one desired that everything be truly shipshape she will see to it that she has a convenient cutting and sewing table. The two may be combined in one. It may be inexpensive, and not be made out of a packing-box, either. Have a carpenter make you a plain table one and one fourth yards in length and somewhat less in width; the top, instead of being nailed on, must form a lid and be attached by hinges. To the upper part of the table, just under the lid, a shallow box is fitted. This is to be used as a common receptacle. Denim pockets of different sizes are tacked to the inside of this box. You can form no idea of the convenience of these pockets until you have tried them. They can be put to so many different uses that they are invaluable. One may hold patterns, another unfinished work, while a third may contain material to be cut out. All of these cut and uncut articles have the virtue of being out of sight, as the box is within the legs of the table.

If one prefers, there may also be a pocket or two attached to the outside of the table just under the lid; these will be found to be especially convenient when the table is used as a cutting-table. My Denver friend has her table painted to correspond with the blue and white furnishings of the room. The top of the table is blue, and the legs are white. Squares of light-weight denim placed under the table will catch the threads and bits of material; besides, as it is so easily kept clean, it will protect delicate summer goods from the possible dust of the floor.

We may have the "pleasant sewing-room," we may have our garments made in the latest style, and yet if we do not take care of them they will never have that air about them that distinguishes the true lady.

If we desire to preserve our good cloth skirts we must buy or make coat-hangers to hang them on. We can make two out of one barrel-stay by cutting it in halves, then tying a string to the middle of each piece. Fancy waists should be hung up on hangers, also.

All dust should be removed from a garment before it is put away. I hear you say "Of course" to this, but do you always do it?

Waist-linings will not be injured, but will be kept wonderfully sweet and clean, losing all odor of perspiration, if they are rubbed quickly with a sponge slightly dampened with ammonia-water.

ELLA BARTLETT SIMMONS.

### SPRING CHICKENS

Not many of us have spring chickens large enough for broilers in June, so we must content ourselves with older fowls. We do not like to sacrifice young, laying hens for the table, but if we have an old hen two or even three years old that has passed her prime as a layer she will be fat, and if care is taken in the cooking an old hen is not to be despised, especially if so treated as to make it like spring chicken.

Have the fowl killed and dressed two or three days before you wish to serve it. Hang it in the coldest place you have. I use the well in warm weather. If you wish the fowl for Sunday dinner, put it in a pot with about a pint of boiling water, and set it over the fire Saturday morning. Do not put in any salt until it begins to get tender, but put two or three of the rustiest nails you can find in the bottom of the pot, having first washed them, of course, and leave them in until the fowl is done. I learned this from an old black mammy who has cooked all her life and who has taught me many valuable lessons in cooking that cannot be found in cook-books. I certainly do not know why rusty nails should have any effect, but I do know that a tough old hen cooked with them will come out as tender and as delicious as a spring chicken. When the fowl begins to be tender it should be seasoned with salt and pepper, and either left to finish in the pot or put in the oven to brown. If, as I said before, it is wanted for Sunday dinner it can be set away until an hour before dinner-time on that day, and then put in the oven in a covered pan, and roasted brown; or it may be cut in pieces, dipped in flour, and fried like a spring chicken.



If you have not planted any seed of the large sweet pepper, get some plants now and set out. I did not know until a few years ago that they were good for anything but mango pickles, but have learned that the good things that can be made of this vegetable are many. Combined with almost any "left-over" fish, flesh, fowl or vegetable the green sweet pepper possesses unlimited possibilities. If the small end is cut off and the seeds removed they make a delicious dish filled with creamed chicken or minced lamb moistened with tomato sauce and served hot. They may be filled with cold flaked fish and mayonnaise and make a delicious salad, or either filled with a vegetable salad and cut into pieces and added to the salad. Both the green and ripe peppers are useful to cut into fancy shapes and use for garnishing.

If you have no cellar or cool spring-house for keeping milk, butter, etc., during the hot weather, I will tell you what a neighbor of mine did. He built a house about ten feet square over his well. The walls were fifteen inches thick, built of small stones mixed with cement, and the roof had an air-chamber below it. Vines were planted, and soon covered the building, helping to shut out the sunshine. Inside this well-house, across one end, he built a trough of the same material as the walls, with an outlet-pipe at one end. Into this trough water was pumped, and the milk, cream and butter vessels set in this cold water. A cupboard was also built along one side. There is a pump in the well, but the well-curb is open, and a pulley is fastened to the ceiling, over which a strong braided rope runs, one end of which is fastened to the well-curb, and at the other end is a galvanized bucket, by means of which fresh meats or anything else which needs to be kept very cold is let down thirty or forty feet into the well. This plan works admirably and no ice is needed. The door and windows of the well-house are kept tightly closed during the day, to keep the hot air out, and opened for ventilation at night, only the screens being closed.

MAIDA McL.

**JUNE**

June in the grass!  
Daisies and buttercups, lo! they surpass  
Coined gold of kings; and for queendom the  
rose,  
Bloom of the month, see how stately she  
goes.  
Blow, winds, and waft me the breathing of  
flowers,  
June's in her bowers.

June overhead!  
All the birds know it, for swift they have  
sped  
Northward, and now they are singing like  
mad;  
June is full-tide for them, June makes them  
glad,  
Hark, the bright choruses greeting the day—  
Sorrow, away!

June in the heart!  
Dormant dim dreamings awake and upstart,  
Blood courses quicker, some sprite in my  
feet  
Makes rhythm of motion, makes wayfaring  
sweet;  
So, outward or inward, the meaning is clear:  
Summer is here.

—Richard Burton.

**DAINTY NECK-RIBBONS**

The neckwear this season is quite elaborate, which means, in other words, that a great many will not be able to afford more than one or two pieces, for elaborate jabots, fichus, etc., are not only expensive, even when made at home, but are also perishable. Fortunately ribbons are being worn very largely, and the ingenious woman can so arrange them as to have different neckwear for different shirt-waists at a comparatively small outlay. Taffeta and double-faced satin ribbons three to four inches wide are the most fashionable and satisfactory, as either side may be used; thus by careful and frequent turning one ribbon may be used a great many times.

It requires only three quarters of a yard to arrange ribbon as in illustration No. 1. Pin the uncut end of your ribbon to the right side of your collar, about

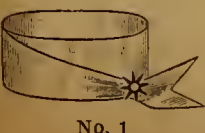

No. 1

two inches from the middle of the back, pass the ribbon toward the left, entirely around the neck, and fasten on the left side with a dainty pin.

Seven eighths of a yard of ribbon will do for illustration No. 2. Pass the ribbon around the neck, crossing at the back evenly, and bring both ends to the front. Tie once, then again, as for an ordinary knot, and tuck the ends under either side. If done deftly, and it is not a difficult task, the sharpest eyes will not be able to detect the fastening. This gives the effect of a made neck-piece.

Illustration No. 3 requires two yards of ribbon. Pass the ribbon around the neck, cross at the back, and bring the ends to the front again, and tie them in an ordinary bow; let the ends hang gracefully, and then tie again farther down in another bow similar to the one above.

Illustration No. 4 shows a plain band of ribbon around the throat fastened with hooks and loops at the back, one half yard being required. Then take a yard of half-inch black velvet ribbon, pass it around the throat, cross it at the back, and bring to the front again, where cross it and fasten with a pretty pin. The ends can either be ornamented with a silk tassel or cut to give a finish.

The new lace scarfs which are now being worn, like all fads and fancies, will probably not be enduring; therefore, it is wise to make the most of them while in vogue. There are many different ways of arranging them so as to change their whole appearance, and almost to create a new scarf with each arrangement, at the same time taking away from the sameness of one's waists.

The narrow lace scarfs, which are about two and one half inches wide and perhaps two yards long, can be arranged daintily and tastefully, as shown in illustrations Nos. 5, 6 and 7. In either case a band of ribbon (satin producing the best effect because of its sheen) should be passed around the throat and fastened at the back with hooks and loops.

To produce the effect shown in illustration No. 5, pass the scarf around the throat, cross at the back, bring both ends to the front, and tie in a dainty spreading bow. This is a very pretty arrangement.

Illustration No. 6 is formed by simply passing the scarf around the neck, the center being at the back. Tie in a small bow at the throat, allowing the long ends to hang gracefully down, almost to the belt.

For illustration No. 7, pass the scarf around the neck, the center being at the back; then proceed to tie a double bow; leave either plain or fasten a brooch in the very center of the knot.

The wide scarfs, which measure about five inches across, of course can be arranged so as to appear more elaborate.

Illustration No. 8 shows the simplest arrangement. The scarf is plaited at the center, passed around the throat, crossed at the back, and the ends brought to the front again, where they are simply fastened with a brooch.

Illustration No. 9 shows the wide scarf arranged like the narrow scarf shown in illustration No. 5.



No. 5



No. 6



No. 8



No. 9

Illustration No. 10 shows the scarf as a sort of fichu, and not passed around the throat. Tie a simple double bow and allow the ends to hang.



No. 10



No. 11

a plain shirt-waist as a dainty neck-piece of lace, and nothing is so universally becoming to all complexions as soft fine lace.

E. L. R.

**SERVING THE SPICY GOOSEBERRY**

The "tartness" of the gooseberry makes it somewhat unfavorable for frequent serving, especially for the housewife who is inclined to economize on sugar—"the sour things do take sech an everlastin' lot o' sweet'nin'," according to the verdict of one of these economizers. An occasional pie is therefore the extent of the gooseberry-serving in many homes, and yet they come at a season when their acid is most grateful to the system and may be served in numerous ways.

GOOSEBERRY FOOL.—Stew one quart of green gooseberries in just as little water as it is possible to use. When soft rub through a sieve to remove the skins; rub them back and forth with a wooden spoon, so that nothing will be left in the sieve but the tough skins. To every pint of pulp add one pint of milk and plenty of sugar. In mixing the gooseberries and milk add the milk very slowly. Serve in small dishes, with cakes. This, although a very old-fashioned dish, is very delicious when well made; and if properly sweetened a very suitable preparation for children.

GOOSEBERRY TRIFLE.—Stew and pulp the gooseberries as above, and add while warm one tablespoonful of butter to every quart. Add the well-beaten yolks of four eggs and one and one half cupfuls of sugar, or more if needed. Put into small glasses, leaving space at the top for the meringue. Beat the whites of the eggs into a perfect froth with three tablespoonfuls of sugar. Heap this on top when the fruit is icy cold. Whipped cream may be used in place of the meringue, if preferred.

GOOSEBERRY PUDDING (baked).—Stew and pulp the gooseberries, and to every pint add three well-whisked eggs, one and one half ounces of butter, one half pint of bread-crumbs and sugar to sweeten. Beat the mixture well, and bake in a buttered dish for about forty minutes. Serve hot or cold.

GOOSEBERRY PUDDING (boiled).—Line a pudding-mold with biscuit-crust rolled out half an inch thick. Fill with unstewed gooseberries, through which sift plenty of brown sugar, and cover with crust. Pinch the edges well together, tie over it a floured cloth, put

into boiling water and boil two and one half hours; turn it out of the mold, and serve with cream or sauce.

GOOSEBERRY SAUCE (for boiled fish).—Stew and pulp one pint of green gooseberries. Put into a saucepan with three tablespoonfuls of the water the fish was boiled in, two ounces of butter, salt and pepper and a little nutmeg. A tablespoonful of sugar is added if the extreme acidity of the fruit is disliked.

GOOSEBERRY TART.—Stem the fruit and sweeten liberally, using fully a pound of sugar to a pound of fruit; add a little water to dissolve the sugar, bring to a boil, and then set aside to simmer slowly until the berries are soft and begin to jelly. Put into small shapes of rich, flaky puff-paste already baked—these are better uncovered—sprinkle sugar over the whole, and serve with sweetened cream. If the tart is quite large a meringue may be heaped lightly upon it.

GOOSEBERRY CATCHUP.—Take twelve pounds of gooseberries, eight pounds of sugar, three pints of weak vinegar and spices to taste. Boil two hours, and bottle. This is a famous old English appetizer, while the gooseberry tart and gooseberry fool were favorite desserts of the eighteenth-century squires in England, and their thrifty dames, who knew how to appreciate this wholesome fruit.

PHEBE W. HUMPHREYS.

**CORN-HUSK MATS**

Select dry, clean corn-husks and shred them into strips with a steel fork. Braid them in three strands, making the strands rather thick. At intervals tuck in a husk which will leave out two ends on one side of the braid. When a sufficient length is obtained sew them into a round or oblong mat with coarse carpet-thread; then shear down the ends to give a stubby appearance. It is best to dampen the husks when braiding them, as they work better. These are suitable for door-mats, and can be made at very little cost.

For inside mats, cut up material that is used for carpet-rags into inch-wide pieces, on the bias if possible, and run them through the middle on doubled carpet-thread in about three-yard lengths. Push the material up close as you go along, tying a knot in the thread to keep it tight, and at the end leave about four inches of thread for the carpet-weaver to tie the ends together. Have it woven like a rag carpet, using hit and miss colors in the center, and some plain color for a border at each end. These make heavy mats or rugs that will not kick up and are very durable. One and one half yards wide by two and one half yards long is a good size, though of course it is best to have them made to suit the places in which you wish to use them.

Many ladies are utilizing their old chenille table-covers and curtains by raveling them out and making them into door-hangings similar to those of rope, with a fretwork border and ornamented with tassels. They are inexpensive and fill a vacant door very nicely. In some localities they are being made by families used to the work, and are very pretty in design.

One must work steadily and often to keep one's house looking at all times trim and kept up, and these home-made articles give a home look to the house that is never accomplished by store furnishings; but care must be taken not to overload the house with one thing. Then, too, do not let sentiment interfere with getting rid of everything that has served its time with you. Either give it away, or, best of all, burn it. The accumulation in some houses would go a long ways toward furnishing some other home if it could be directed in the right channel.

K.

**MARKING TABLE-LINEN**

A pretty and simple way of marking table-linen is to put the initial about three inches long in the corner. It should be done in cross-stitch, evenly and smoothly. When great care can be used in washing, flax thread of color may be used, but white is sure to be satisfactory.



## A FAIR FIGHT

By Mattie Dyer Britts

## CHAPTER V.

LONE in her own room that night Virgie thought this thing over, without coming to any conclusion.

"The mystery only deepens," she said. "Why should he have asked that promise? It must have something to do with this business, though I can't see what. He has as much right to open a store here

as papa has. I don't understand it at all; but if I ever saw a man look good and noble he did as he stood there to-night. I'm not a bit afraid for my ring now, and I'll keep my promise, come what will, Herbert!"

Then she blushed and laughed, alone in her room, and did not even dare for a moment to glance at her own face in the mirror. Somehow, the next day she would not go out, though she had intended doing so, lest she should meet him in the streets. "I don't know where I will see him first," she thought, "but I don't want it to be in a crowd, so I won't risk it."

At dinner Miss Maggie asked, "Well, Jason, is the new store open to-day?"

"No, not a sign of any one there," replied Mr. Van Gillen, "though the young man is still in town. Judge Wright was in my store this morning; he has met the young rascal, and thinks him a mighty fine fellow."

"Judge Wright is a fine man himself," spoke up Virgie, "and ought to know one when he sees one. I like Judge Wright."

"So do I, my dear. This fellow may be all right, too; and so he lets me alone I won't trouble him. But he had best keep out of my way in business matters."

"Have you learned his name?" asked Miss Maggie.

Virgie busied herself with her plate, and was looking intently at it when her father answered, "It's a queer sort of name—Begole, or something like it."

"Begole? I never heard the name before," said Miss Maggie. "Must be French descent, I judge. I wonder what church he attends?"

"I don't know. Probably not any at all. There's a chance for some missionary work for you, Mag. Though I want it distinctly understood that I prefer my family to have nothing at all to do with him in any way."

"Well, brother, we are not likely to. Virgie, are you ready for pudding now?"

"No, aunty, thank you; I do not care for pudding to-day."

"But it is your favorite chocolate, with lemon sauce."

"I don't care for any, Aunt Maggie."

"Why, what is the matter with you? Jason, I believe this child will have to have a tonic. Her appetite is falling every day."

"Well, then she had better see the doctor," said Mr. Van Gillen.

But Virgie laughed merrily. "Nonsense, papa and Aunt Mag! I am perfectly well; there is nothing at all the matter, only the hot weather, perhaps, makes me a little lazy. My appetite is all right; I don't need the doctor."

"Humph! I'm not so sure," grumbled Aunt Maggie. "The fact is I don't think you have been quite like yourself since you came home from Sue's."

"Our experience on the way home was enough to shake anybody up a little, wasn't it?" said Virgie.

"No doubt; but I don't feel quite easy about you, child."

"I hope she hasn't been falling in love out there on the plains of Iowa," remarked Mr. Van Gillen.

Virgie laughed again. "I'm not in love with anybody but you, papa, nor likely to be. Don't you worry a mite about your girl; she's all right."

"Well, I hope so," said Mr. Van Gillen, as he rose from the table.

Virgie surely was not sick, but what was it made her run up to her own room, lock her door, throw herself on the bed and take a good fit of crying? She couldn't have told herself why she cried, but it served to relieve her, and she was quite cheerful when her father came home to supper.

There was a missionary meeting at their church that evening. Good Aunt Maggie never missed any meeting when she was well, so she asked Virgie to accompany her. Virgie declined, saying she would rather stay and keep her papa company, as he was not going out that night. Aunt Maggie went off alone, and Virgie thought she would pass the time working a bit at her Battenberg lace. She brought her work down into the sitting-room where Mr. Van Gillen was reading the evening paper, and sat down near the drop-light to follow the intricate pattern. A half hour later there was a ring at the door-bell, and presently Jane appeared in the door.

"Gentleman to see you, Mr. Van Gillen."

"Show him in, Jane."

"Walk in, sir; he's at home."

They heard Jane say the words in the hall, and then a gentleman entered the door, and

Virgie felt all the blood in her body rush to her heart, for Herbert Begole stood before them.

Without taking the least notice of her he bowed to her father, and said, "Mr. Van Gillen, I believe?"

Mr. Van Gillen had risen, and spoke very stiffly, his face flushed, his brow frowning, "Yes, sir; that is my name."

"Mine is Begole, from Grand Island."

"Yes, sir. I have heard of you. Will you be seated?" pushing forward a chair.

Begole stood an instant, with a half glance at the lady in the room, which reminded Mr. Van Gillen of his politeness.

"This is my daughter, Miss Van Gillen, Mr. Begole."

Virgie rose and bowed coldly. "I am pleased to meet you, Mr. Begole."

"I am also glad to know you, Miss Van Gillen," he returned, with a formal bow, not a single shadow in the manner of either to tell that she had once been tightly clasped to his bosom in a whirl of raging waters.

He at once turned his attention to Mr. Van

look up she caught one glance from Herbert's dark eyes, and it told her not to be uneasy—he was equal to the occasion. He promptly went on, "But I have been thinking, sir, that it might be we could come to some conclusion by which we should be mutually benefited. It is a vast advantage to a young man to have the advice and counsel of an older business man, and it is sometimes a benefit to an older house to have a strain of new and younger life infused into its management. I have sufficient means to start up by and for myself, without any man's aid, but I have decided to come to you, and if it should be altogether agreeable to you, to buy a half interest in your concern; in other words, to ask you to take me into partnership with you."

Virgie was holding her breath now for sure. Mr. Van Gillen, his face hot and red, sprang to his feet, and facing his young caller, said, shortly, "Well, sir, I like your cheek! I admire it! If you have heard anything at all of me, sir, you are a pretty hold one to come to me with a proposition like that!"

"Is there anything wrong in it?" asked Herbert, coolly.

"It is preposterous, sir! Oh, yes; no doubt it would be a good thing for you, a mere stranger, come here from nobody knows where, if the leading merchant of the town, a man who has worked a lifetime to earn his reputation, would pick you up and take you

not failed, nor is my bank-book empty. I have run the most successful dry-goods business in this town for many years, and I expect to do so still. Do you understand me, sir? I expect to do so still, and the man who means to come into competition with me had better think twice before he makes the experiment."

Begole rose, but still kept his face and manner as calm as a May morning, as he said, "I may presume, then, that you refuse to accept my offer?"

"I refuse, young man, most decidedly. You may go in to oppose me, but you can't go in with me, nor under the support of my name."

"The support, Mr. Van Gillen, you will find I did not need. That is not my reason for coming to you. As to the opposition, well, it will be your own fault if there is any war between us."

"There is war, sir, with any man who tries to infringe on my rights."

"That I do not propose to do. But you are aware that any man who goes into business has himself the right, in perfect honor, to do all he can in a fair way to uphold his own house. If he does anything to pull down others in the same line he is a dishonorable man, I care not who he may be nor what his age and standing."

Mr. Van Gillen took one step forward. Virgie dropped her lace, and clasped her hands, biting her lips to keep back the words that longed to come.

"Sir! Young man! Do you intend to be personal in your remarks?"

"No, sir, I do not. I shall always be as respectful to you as if you were my father" (what made Virgie suddenly catch up her work and bend over it glowing rosy?); "but you must understand me fully. I shall be perfectly fair and upright on my side of the street. I shall also expect you to be perfectly fair and upright on yours. And now, as we shall not come to any better understanding, allow me to wish you good-evening. Miss Van Gillen, good-evening to you."

He bowed to them both, and was out of the room before either could have spoken a word, if they wished.

Mr. Van Gillen dropped back into his chair, his face red and angry, repeating over and over, "The cheek of that fellow! The cheek of him! I admire him! I do! He's a specimen of American pluck, he is!"

Virgie let her lace fall to the floor, and coming to her father's side, she sat down by him and began, soothingly, "Yes, father, he is a very good specimen of young American pluck, and I wish you had taken him in with you."

"What, you! You dare! You take his part!"

"No, father, I take yours," said Virgie, too serious to use the childish "papa" now. "You are not so young as you once were, and you do work a great deal too hard, managing all that trade and looking after all those clerks. If anything were to happen to you what in the world should I do? What would become of me, father?"

"There, there, don't you worry, child!" as she bent over him and softly stroked the gray hair back from his hot brow. "Nothing is going to happen to me for many years yet."

"But, father dear, you don't know that for certain. I wish you would take some younger man, this one or some other one, in with you, and let them relieve you of part of the care. Won't you?"

"Is it for me or for the handsome young man you are pleading, daughter?"

His eyes read her face keenly, but she did not shrink from his gaze.

"It is for you, and for no one else in the world, father! I wish you would take a partner for your own sake."

"Well, I won't, and so there's an end of it, child! When I feel that I need one, I promise you to do it. But as for this darling popinjay—no, I'd see him dashed first! All I have to say to you, my dear, is, don't let me catch him fooling around you! He knows you'll have a plum when I am gone, and he can look out for number one. You watch out for him!"

"Father, don't talk silly. I—" she was going to say "I don't even know Mr. Begole," but she felt that she did know him very well indeed, and that the more she knew of him the better he stood with her. That wouldn't do to tell her father, though. So she finished her sentence, "I am not going to let any one take me away from you."

"See that you don't yet a bit. There, daughter, I believe I will go down town a little while. That young scamp has quite upset me for reading this evening. I'll not be gone long, but you needn't sit up for me."

He went out, but Virgie did not take up her lace-work. She was glad Aunt Maggie had not come home yet from meeting; she wanted to be alone just now. She walked up and down the parlor, her hands clasped above her head, in her favorite attitude, her face aglow with smiles, if not actually triumphant.

"I see it all now! I see it all!" ran her thoughts. "The dear, noble fellow! He thought if papa knew he had saved my life it would be his hands, and he could not refuse anything that was asked of him! That is true, too! How papa would feel if he only guessed! I could hardly keep it back while they were talking. Now he must let me tell papa, and what a triumph for him, my dear, splendid, brave knight! Oh, but I



"THIS IS MY DAUGHTER, MR. BEGOLE"

Gillen as coolly as if she had not been within a hundred miles, and in some strange way Virgie felt her own excitement give place to a feeling of calm security, as if she had nothing to fear or dread from this very unexpected visit.

"You are doubtless surprised at my call, Mr. Van Gillen," began Herbert.

"Well, considering the peculiar circumstances, I admit that I am, Mr. Begole."

"I hope, however, that you will pardon the liberty I have taken, considering, as you say, the peculiar circumstances. I wished to talk with you on a matter of business, and thought you might have more time during your hours at home than during the busy rush of the day."

"Well, that's a good one to begin with," thought Virgie, bending over her work and not even allowing herself to smile.

"Ah, yes; we are rather rushed at my place in business hours. I do not see, sir, what business you can have to talk over with me, though."

"I think I do if you will permit me the liberty from a younger man to an older one, and no doubt a much wiser one, in such affairs."

"Good! He'll win his way with papa," was Virgie's thought at that.

"You have doubtless been informed," went on Begole, "that I contemplate going into the dry-goods trade in this little city."

"I have heard so, yes," very stiffly.

"At the same time, Mr. Van Gillen, I assure you I do not wish or intend in the least to interfere with your trade."

"I defy you to do it!" answered Mr. Van Gillen, a trifle hotly, so that Virgie began to hold her breath with anxiety. Chancing to

under his wing! Oh, yes; very fine for you, to be sure!"

"Papa!" said Virgie, in a low, frightened tone, her face quite pale.

Begole turned and gave her one reassuring smile, his manner perfectly composed, and her father answered, "You keep still or go out of the room, Virgie!"

Virgie did not want to go out of the room, so she determined to "keep still" if she possibly could, and bent over her lace, not losing one word of the conversation.

Mr. Begole spoke in an easy tone. "It had struck me in just that light, Mr. Van Gillen. I am, as I told you, entirely able to set up for myself, independent of any man. But I thought—"

"Oh, yes, you thought, as I believe you have said, that I am an old-fashioned fog, who does not run his business up to date—"

"Beg pardon one moment, Mr. Van Gillen. Did I understand you to say that I have called you an old-fashioned fog to any one?"

"I have been told so, sir, or words to the same effect."

"Then your informant must have been decidedly mistaken."

Virgie flashed one bright look at Herbert, which he caught before he went on.

"I did say, in speaking to Judge Wright of this matter, that there were some men who preferred to run business in an old-fashioned way, and would admit of no new ideas. I asked the judge if you were one of those men, and he said he thought you were not. Had his judgment been otherwise I should not have troubled you with this call."

"Well, sir, you need not have troubled me with it in any case. I do not want a partner. I do not need one yet awhile. My mind has



am a prond and happy girl this night! How grandly he carried himself, and how kind and sweet he looked at me, to hid me have no fears. I will have none. It will all come out right. My Herbert—yes, I will say even that this once—can manage a worse case than this, and I'll trust him. But oh, isn't he a real man! I'm like papa; I admire his 'cheek'! Ha! ha!"

She laughed a musical laugh, and it was a pity her hero could not have seen her in her beauty of happiness as she walked up and down the room, for she was fairer to look upon than she had ever been in the gilded halls of fashion.

Aunt Maggie, when she came home from church, saw that something had happened to excite the girl who had been the apple of the good woman's eye ever since she came, at the death of her sister, Virgie's mother, to take charge of her brother-in-law's household. But when she asked who had been there, and heard of Mr. Begole's call, she saw nothing in that to make any difference, so she concluded it was nothing more than mere youthful spirits, and dismissed the matter from her mind.

CHAPTER VI.

Just beyond the town a beautiful little suburb stretched out, known as Silverdell, a wild green spot, through which ran a sparkling creek, and within whose sylvan shades one might fancy the hum and whirl of workaday life far away. It was reached by a lane which crossed the rustic stone bridge directly beyond the turn of the long street, and one standing on the bridge, or near it, would not be visible to a person on the city side of the turn.

Over in Silverdell lived a number of the working-people of Ashland, though it was at the other end of the town from what was known as "factory hill," the region where busy mills and towering smoke-stacks kept up their dust and soot and din from morning until night. It was the home of a woman named Joanna Klein, who had, before her marriage, lived for years with the Van Gillens in the same capacity as Jane occupied at present—cook and housemaid.

Joanna's marriage had not been a grand success. Hendrick Klein was a pretty fair husband and provider—when he was quite sober. That occurred most often when he was out of work, and consequently short of money to buy liquor, so Joanna had put her own shoulder to the wheel and worked as busily as ever to help earn a support for three little tow-headed Kleins, who did not care whether anybody worked or not so long as they could play in the sand and build dams on the creek bank of their little cottage.

Joanna was very neat with her needle, and Miss Maggie and Virgie were glad to give her most of their plain sewing. Several days had passed since Mr. Begole's call, and they had, by common consent, seemed to avoid mentioning him at home, so as not to disturb Mr. Van Gillen's good-nature, and Virgie did not know how things were coming out with his store. She had been in her father's store once, but some odd impulse prevented her from glancing directly across the street, though the sound of hammers in that direction gave her an idea that business had begun, for she knew the vacant room would require considerable fixing up before it was ready for its new purpose.

She set out one afternoon to go over to Joanna's to inquire whether she could sew for them the following week, and though the walk was not a short one, she chose to go that way. It might have been for the reason that she had rather be alone with her thoughts just now than to be in the company of somebody to whom she would be obliged to talk.

She was walking slowly along, her pretty white parasol over her head, her summer hat pushed back for coolness, when she chanced to hear a rapid, firm step coming from the bridge. She had only just made the turn and looking up she was greatly surprised, but not at all displeased, to see Herbert Begole a little way in front of her. He saw her, too, and stopped until she came upon the stone bridge, his fine face lit with a sudden glow.

"Miss Van Gillen!" he exclaimed, his hand held out, as she drew near. "I can't tell you how glad I am to meet you!"

"You are not more glad than I am," answered Virgie, frankly. "I have been wishing to see you ever since you were at our house the other night."

"You have?" The glow deepened on his handsome features.

"Indeed I have—with good cause. But I certainly did not expect to meet you out here in Silverdell."

He laughed, and said, lightly, "Is that what you call these classic shades? Well, I have just been over here to engage a man to come and help put up the shelves in my new room. Fellow by the name of Klein, I think; they tell me he is a pretty good workman."

"Yes, he is when he is sober. He married an old hired girl of ours, and I am on my way to see her now, to get her to sew for us next week."

"Are you? I wish I had stayed a little longer, then; I might have had the chance to walk back with you—that is, if you would allow me. So Klein likes to drink, does he?"

"He drinks up nearly all he makes, Mr. Be-

gole; but he is a fine workman when he isn't drunk."

"Glad you told me of that; I shall see to it that he doesn't get his money until his work is done, for his family's sake."

"Oh, I wish you would do that, Mr. Begole! It would be a favor to me, for the sake of poor Joanna. We used to think a good deal of her, and do yet."

"I certainly will do it, Miss Van Gillen. There isn't much I would refuse to do if you asked it of me."

He had come quite near her, and was leaning against the bridge-railing, looking into her face earnestly as he spoke.

She returned his look frankly, and quickly answered, "I know that; I know you kept still for my sake when papa was—well, rather cross the other night. And oh, Mr. Begole, I know the mystery now! I know why you asked that promise of me! I have guessed it all!"

"You have?" still looking at her with a warm smile.

"Yes, indeed! You thought if my papa knew what you had done for his daughter he might not feel at liberty to refuse anything you asked of him, and you judged rightly. Oh, Mr. Begole, you must release me from that promise right off, and let me tell him all about it! Won't you, please?"

He laughed, and shook his head.

"Not yet, Miss Van Gillen. I can't do that quite yet. You see, don't you, that I would not have felt myself at liberty to go to him as I did—not have thought I had any right if I had tied my own hands by letting him know that I had been so happy as to be of some little service to his daughter?"

"Some little service?" Mr. Begole, there is never a night now that before I sleep I do not pray for the man to whom I owe my life!" She spoke with deep emotion. Herbert instantly took off his cap and stood a moment in reverent silence; but he let his hand rest for a second on hers, as it lay on the stone wall of the bridge.

"Miss Van Gillen, I shall be a better man for knowing that."

"I believe that you are one of Nature's noblest men now!" cried Virgie, impetuously. "Oh, I know how hard it was for you to take papa's rudeness! But indeed you don't know how sorry and ashamed he will be if you will only let me tell him!"

"My dear child, don't you see that I don't want him to feel that way toward me—and particularly just now? I want to stand with him as one business man with another, each one honorably trying to succeed, and yet both friends, as we should be. I want it that way, because I believe in that way I can best overcome his dislike to me. You perceive I understand the case, don't you?"

"I suppose you do."

"I do. I want to win my way and gain his respect by my manner of conducting business. I am especially anxious to do it now for the very position in which we are placed. Then, if I can do it, and make him my friend, I shall have something else to say, and after it is said you may tell him all. Can you guess what it is, Miss Virgie?"

She flushed at his use of her name, but the tone of almost reverence in which he spoke it forbid her to be offended. She looked down at the sandy creek, and only answered, softly, "How should I guess, Mr. Begole?"

"I hope you do. But I have a name and a place to win here among strangers before it is said. Meanwhile I wonder—do you think it would be best for me to ask to call upon you at your home?"

"Must I be perfectly frank and honest with you, Mr. Begole?"

"I trust you will always be that—do not fear or hesitate to say anything to me."

"Then I will tell you what papa said, though it makes me ashamed to do so; but please remember he does not know, won't you?"

Her eyes were lifted beseechingly to his face, and he replied, quickly, "Please, on your part, forget that there is anything to know for a little while, my little friend."

"No, I can never do that. My papa said—"

He laughed again as she hesitated and blushed deeply with mortification.

"Don't fear—go on! He said he did not want you to have anything to do with me, didn't he?"

"Yes, he did!"

"Then he shall not be worried—until I can gain his friendship for myself. I have been wondering, these two or three days, if I might venture to call—that is one reason I am so glad to have met you here. For your sake, you understand—I shouldn't care on my own account—but I care too much for you to wish to be the cause of the slightest trouble to you. You won't be angry at me for saying that?"

She shook her head, and stood silent.

"Then I won't say more now. Miss Virgie, if I can't see you often I shall need something to help me keep a brave heart till this battle is won. I have here"—he touched his vest-pocket, with a smile into her eyes—"a little talisman which I meant to give back to you to-day. I think now I should like to carry it there awhile longer. May I?"

"Mr. Begole, look at this!" She held up her hand, on which shone the ring sent her by Mrs. Pearson.

"A new one, is it? It is very beautiful! I wonder if your father gave it to you?"

"No, not papa; Mrs. Pearson made me a present of it, to replace the one they think is in the river."

"Ah! in the river?"

"Yes." She told him the little story, and said, as she finished, "You see, Mr. Begole, I have kept your little secret safely. But I wish I might tell it now. It would make papa your friend at once."

He shook his head again.

"Let me make him my friend simply as man to man, or at least let me try. Promise me to hold the promise sacred a little longer, won't you?"

"I will if you ask it."

"I do ask it for a few days more. Miss Virgie, I am going to ask something else."

"Well?"

"You know that your father thinks there is to be 'war,' as he says, between us; but it is not so on my part. Still business must be attended to. I want to ask you, if there should seem to be further trouble, not to judge me too quickly or too harshly, will you?"

"Mr. Begole, look at me!"

"I should like to look at you all the time if I might."

"Right in the eye, sir! Now, do you think I am likely to think anything of you which I—which I ought not to think? Don't you believe I can trust you?"

"I know you may do that through thick and thin, you dear, blessed girl! Miss Virgie, if I keep you here it may make you the subject of gossip, and I may make more of a dunce of myself than I mean to just now."

"Oh, yes; I ought not to have stayed so long. I forgot 'myself.'"

"Then, much as I would like to do so, I won't keep you any longer. You think I may not go back to Klein's with you?"

"Oh, no—not this time!"

"Only one thing more, then—when you judge it best for me to call on you, give me the least hint in the world, won't you?"

"I'll see about that."

"Good-by, then!"

He held out his hand. She gave him hers, and he, with a swift glance around to see that no one was approaching the bend, quickly lifted it to his lips, and was gone the next instant. Virgie walked on, her face rosy, her lips smiling, while she said to herself, "Well, did any girl ever see a man like that? Papa is right; he has 'cheek' enough for anything, bless his noble soul!"

She went the rest of the way with swift steps, and found Joanna in a state of great delight when she reached the tiny cottage, which, by the way, was Joanna's own, a gift to her from Mr. Van Gillen, and not in Hendrick's name at all.

"Hendrick's got work at last," said the patient wife. "He hasn't had a blessed job for six weeks, Miss Virgie dear, and I've nigh about worked my fingers to the bone to keep the mill going."

"I don't doubt that, Joanna. I've come to get you to do some more work if you are not too tired to sew for us next week."

"For you? Lord bless you, Miss Virgie, I haven't never seen the day when I wasn't glad to work for you and Miss Maggie! Sometimes, when Klein gets to acting up I just wish I was back in your kitchen, having a good time like I used to. Ah, Lord! these men do worrit a body half to death, so they do! I never want to see you get married, Miss Virgie, darling!"

Something made Virgie blush crimson at the honest speech, and it did not escape Joanna's sharp eyes, though Virgie's answer was, "I'm not likely to do that, Joanna, for a long time, if ever. But when I do I promise you that you shall come and help with the 'fixings.'"

"I'll do it, sure! Say, Miss Virgie, I've just seen one man that I do believe is good enough even for you. He's been here this very afternoon. But if what Klein says is true, your pappy wouldn't hear to that; no indeed!"

"Why, who can this wonderful fellow be?" asked Virgie, smiling, as if she had no idea who had called on Joanna that day.

"Well, it's the new man that's going to keep store in town. Don't you believe, he come to get Klein to work for him, and Klein's gone to get home some o' his tools this blessed minute. Klein says your pappy is red-headed mad because he's goin' to set up right across the street from the old store."

"Well, I think papa is rather displeased; but you know, Joanna, anybody else has as good a right to sell goods here as papa has."

"To be sure! If the young chap had treated Mr. Van Gillen mean I wouldn't like him myself—you folks have been too good to me! But Klein says he hasn't done no such thing."

"Oh, no; I am sure he has not. He is too true a gentleman," said Virgie, hastily.

Joanna opened her eyes, and said, a bit astonished, "Then you've seen him, too?"

"Yes; he called on papa the other evening."

"Did he? Well, that looks like he was a square man, don't it? I believe he is, too, Miss Virgie dear. He did talk the nicest to Klein, and to me, too. And just look here!" She jumped up, and taking a little box from the mantelpiece, she showed Virgie two bright half dollars lying inside. "See; that's what he give them young ones not an hour ago!" she said, in a pleased tone. "He picked up them little rascals, and held 'em on his lap, and talked to 'em, and when he went

away he give 'em each one o' these, and said it was to buy 'em a new apron! Why, land! that'll get 'em a nice gingham dress apiece, and Lord knows they need things! I tell you, Miss Virgie dear, most o' the men as comes here after Klein don't want nothing o' the young ones only to keep out o' the way. That's what makes me know that feller's got a good, kind heart in him, and he's that handsome! Why, I wouldn't care if you did shine up to him, my darling; and if he wants to, you just let him, pappy or no pappy, says I!"

"Joanna, Joanna, you don't know what you are talking about!" cried Virgie, laughing, but blushing so rosily that wise Joanna gave her a keen look, and nodding her head, said in her own mind, "Well, I shouldn't wonder if she had seen more o' him than she'll let out! I do hope they will take a fancy to each other." But to Virgie she only said, "Now, if Klein will only behave himself, and keep sober till the work's done, maybe he can get more in the same place. I wish I could see that feller again, and I'd ask him not to give Hendrick a single dollar till he gets through his job."

"Oh, you need not worry, Joanna; he will not do that. I told him—I mean," she rapidly changed her words, seeing the sharp glance Joanna bent on her face, which had turned so suddenly scarlet, "I mean that I can see Mr. Begole, and I'll give him a hint not to pay Hendrick just now."

"I wish you would, Miss Virgie dear. I can make a little to run on, and then when Klein gets some money worth while it will do us some good, you know. He'll bring it home to me if he gets it all at once, but if it comes by little it goes into his own pocket, and then it goes out for the drinks."

"Very well; I think I can help you a bit in that, Joanna. Now about the work. I will tell you what Aunt Maggie wants, and you can come to us or we will send the work to you, as you prefer."

They talked only about the work, until a few minutes later, when Virgie left the cottage. Joanna stood in the door and watched the slim figure until it disappeared at the turn to the bridge.

"She told him, did she?" was the good woman's remark, as she went back to her ironing. "I wonder where she saw him to tell him, and if it wasn't her that sent him after Klein? Well, maybe Joanna Klein ain't quite so smart as some folks, but she can see through a millstone when there's a mite o' a hole in it! So, Mr. Van Gillen, I hope as you've met your match—and dear Miss Virgie has met hers, too, and it wouldn't surprise me a bit if she had! But I'll lay low and say nothin' till she gives me leave."

[TO BE CONTINUED]

DANDELION

Unnamed among the garden walks,  
Unknown in beauty's bower,  
It blooms, and cares not which it be,  
Bright weed or homely flower;  
Yet brave as any red-cross knight,  
And modest as a lass is,  
It might be the Jeanne d'Arc of buds,  
Or Galahad of grasses.

The rose for it no envy knows,  
The lily feels no pity;  
Unminded in the meadows green,  
Undaunted in the city,  
It blazes in the skirts of Spring,  
With grass-blades round it twining,  
As if a sunbeam should take root  
And bloom instead of shining.

And when its little day is done,  
On rounded column slender,  
Triumphant rises in its place  
A silvery, silken splendor;  
A wondrous, wavering winged thing,  
Free the free winds to fly on—  
It is the flower's immortal part,  
Soul of the dandelion.

—W. H. Woods, in Youth's Companion.

CHINESE ETIQUETTE

There is an invariable observance of the polite Chinaman that Occidentals cannot seem to grasp or appreciate at its real value, or lack of value, and that is his etiquette of what seems to them impertinent curiosity. When Li Hung Chang visited Europe and this country a few years ago I was much amused at the comments of the English and American papers on the numerous personal questions he put to his various official entertainers. According to Chinese etiquette they meant no more to him than "how d'ye do?" does to us, when we ask it of a friend at one moment and forget his reply the next. When two Chinamen meet they shake hands—that is to say, each shakes and squeezes his own hands and covers his head. If the meeting is after a long parting, after the hand-shaking is over they rub shoulders until they are tired. Instead of inquiring after one another's health, they use a formula about like this: "Have you eaten your rice? Where are you going? What is your business there? What did you pay for your shoes? How old are you?" This last query must on no account be omitted, but it seems to be the very one that got poor old Li the most cordially criticised and misunderstood.—Selected.



# HEADACHE

"Both my wife and myself have been using CASCARETS and they are the best medicine we have ever had in the house. Last week my wife was frantic with headache for two days, she tried some of your CASCARETS, and they relieved the pain in her head almost immediately. We both recommend Cascarets."

CHAS. STEDEFORD,  
Pittsburg Safe & Deposit Co., Pittsburg, Pa.



Pleasant, Palatable, Potent, Taste Good, Do Good, Never Sicken, Weaken, or Gripes, 10c, 25c, 50c.

... CURE CONSTIPATION. ...  
Sterling Remedy Company, Chicago, Montreal, New York. 317

NO-TO-BAC Sold and guaranteed by all druggists to CURE Tobacco Habit.

## Reversible LINENE Collars and Cuffs.

Stylish, convenient, economical. Made of fine cloth, finished in pure starch, and exactly resemble fashionable linen goods. No Laundry Work When soiled discard. Ten Collars or five pairs of Cuffs, 25cts. By mail, 30cts. Send 6 cts. in stamps for sample collar or pair of cuffs. Name size and style.



REVERSIBLE COLLAR CO., Dept. C, Boston, Mass.

## ALLEN'S FOOT-EASE

A Powder for the Feet. Shake into your Shoes



Allen's Foot-Ease, a powder for the feet. It cures painful, swollen, smarting, nervous feet and instantly takes the sting out of corns and bunions. It's the greatest comfort discovery of the age. Allen's Foot-Ease makes tight-fitting or new shoes feel easy. It is a certain cure for ingrowing nails, sweating, callons and hot, tired, aching feet. We have over 30,000 testimonials. TRY IT TODAY. Sold by all Druggists and Shoe Stores, 25c. Do not accept an imitation. Sent by mail for 25c. in stamps.

FREE TRIAL PACKAGE sent by mail. Address ALLEN S. OLMSTED, Le Roy, N. Y. (Mention this paper).

## A \$12 Bath Cabinet FOR ONLY \$5.00

Our new 1902 style Square Quaker guaranteed best of all cabinets at any price. Has real door on hinges, steel frame, best materials, rubber lined, folds flat, lasts 20 years. Turkish and vapor baths at home 8c each. Open the millions of pores, sweats poisons out of the blood, keeps you clean and healthy, beautifies complexion. Physicians recommend it for Colds, La Grippe, Rheumatism, Neuralgia, Obesity, Female Ills, all Blood, Skin, Nerve or Kidney troubles. Money refunded after 30 days use, if not as represented. Price with heater, directions, formulas, \$5.00. Face Steamer \$1.00 extra. Order today. Write us. Valuable Book FREE. Agents Wanted. Big Wages. Splendid Seller. World Mfg. Co., 37 World Bldg., Cincinnati, O.

## ANY MAKE BICYCLE you want at one-fourth price.

600 Second-hand Bicycles, \$3-\$10 all makes, good as new to NEW 1899 and 1898 \$8-\$13 MODELS, High Grade, 1900 Models, best makes \$11-\$20 all styles, fully guaranteed. Great Factory Clearing Sale. We ship anywhere for inspection. Send your address. If you are UNABLE to BUY we can assist you to EARN A BICYCLE distributing catalogues for us. Write for agency and commence work at once. HEAD CYCLE CO., Dept. 43B, Chicago.

## BICYCLES FOR EVERYBODY. NO MONEY IN ADVANCE.

Shipped direct to anyone and guaranteed as represented or money refunded. Save agents large profits and get a wheel at rock bottom wholesale price. Our Arlington Model K is the greatest bargain ever offered; in lots of one or more at \$14.85 \$35 "Arlington" \$16.50 \$40 " " \$18.50 \$50 "Oakwood" \$21.50 Good wheels \$12.50, \$11.00 & \$10.00 Stripped Wheels \$7.00 the Arlington & Oakwood are strictly high grade and the best that can be made. Thoroughly tested and fully guaranteed. Over 100,000 riders can testify to their superior quality, style, construction and workmanship. Illustrated catalog free. CASH BUYERS' UNION, 162 W. Van Buren St., B-7, Chicago, Ills.

## \$1,000 SALARY PER YEAR!

Ladies or Gentlemen We have shared the general prosperity of the country, and we now need one or two permanent representatives in each state to look after our interests, manage our agents, and attend to collections. This position involves no canvassing and is a bona fide weekly salaried position, with all expenses paid, to the right party. It is mainly office work conducted at your own home, with an occasional trip out among the agents. No investment required. Also three salaried vacancies in the traveling department. Enclose references and self-addressed stamped envelope to PROVIDENCE CO., 444 Carlton Bldg., CHICAGO.

## AGENTS WANTED

150 Per Cent Profit on our Useful Household Novelties. We have thirty quick-selling specialties needed in all homes. Sell from \$1.50 to \$3.00 worth at each house. Write for new catalogue. Illinois Cutlery Company, Decatur, Ill.

## STRANGE WEDDING CUSTOMS

Among the most curious wedding customs are classed those of the Koreans. It is said that in Korea the woman must be as mute as a statue throughout her entire wedding-day. Should she say one word or make a sign she would be ridiculed by her friends and family and lose caste forever, though her husband is free to taunt and to try to provoke her into saying something. There are places where the eating or drinking from the same cup is all the wedding ceremonial that the people have. With some people it consists of the two drinking rum from the same cup as a sign of their linked lives. In still other parts of the world the two families meet at a banquet and signify by their partaking of a meal together that an alliance has been effected.

In Maoriland and Burma there is no ceremony, marriage being regarded as a business partnership. It is said by one who has lived there that all the gods and goddesses of Maoriland help the Maori whose wife betrays or dishonors her husband, but he may trade or exchange her to suit his own sweet will. In Zululand hair-dressing is an important feature with both bride and bridegroom. The head of a Zulu bride is closely shaved, except for the hair which is left to aid in the cone-shaped erection which is the lawful coiffure of a Zulu wife.

In the Philippines the marriage laws are all in favor of woman, and with her it is a clear case of "What is yours is mine, and what is mine is my own." She adds her husband's name to hers, and the children take the name of both.

In Siberia a bride on coming to her husband's house is required to prepare a dinner with her own hands as a test of her skill as a housewife.

The Japanese bride, dressed in a long white silk kimono and white veil, sits upon the floor facing her future husband. The tables stand near, and upon one are two cups, a bottle of saki, and a kettle with two spouts. Upon the other are a miniature plum-tree, typifying the beauty of the bride; a miniature fir-tree, which signifies the strength of the bridegroom, and a stork standing upon a tortoise, representing long life and happiness. The two-spouted kettle is put to the mouths of the bride and bridegroom alternately, signifying that they are to share each other's joys and sorrows. The bride keeps her veil, and it is used as her shroud when she dies.—Selected.

## THE CARE OF PETS

When Lemuel Gulliver was captured by the farmers of Giant Land they made him dance ten hours a day, and roused him from his best sleep to be teased by the children of gaping neighbors. Young hoodlums would tickle his ribs with fingers resembling hairy fence-rails, and a girl "not much bigger than a boarding-house" gave him a kiss that stunned him for thirty seconds. They meant no harm, but when he contrived to find a new home he passed three hours in prayers of fervid thanksgiving.

With similar emotions many four-footed pets would hail the day of deliverance from the hands of their protectors. Little puppies that would ask no greater favor than to be left alone are carried about and coddled till their shrieks of distress can be heard in the middle of the next block. A year later, when their roaming instinct has awakened in all its force, they are chained or kenneled. A hound is naturally almost as restless as a ferret, and to restrain his freedom of motion is worse cruelty than neglect; so much so, indeed, that there is little doubt about its penalty being enforced in the form of hydrophobia, a disease as dreadful as fever and madness combined. In Turkey, where thousands of ownerless dogs are left to starve or feed on refuse, hydrophobia is unknown. It is unknown in Egypt, in Persia and in western Arabia, where the freaks of the dog-star stray in the neighborhood of one hundred and twenty degrees Fahrenheit.

As a rule it may be said that the happiness of household pets depends chiefly on their freedom from ill-timed restraint.

Another very common mistake is the idea that superfluous kittens or puppies can be put out of their misery in a merciful manner by flinging them into the river.

I am still haunted by the memory of a river-bank where I saw half a dozen little shepherd puppies float away with yelping appeals for assistance, while their poor mother nearly strangled herself in frantic attempts to break her leash and fly to the rescue of her youngsters. She had overtaken the drowning committee unawares, and had then been secured with a stout handkerchief and a boy's waist-belt; but the whole tragedy could have been avoided by taking away her pups during her incidental absence, one at a time, and holding them under the water in a common wash-tub.—The Chautauquan.

N. E. A.

Reduced rates via Queen and Crescent Route from all points north to Charleston, S. C., account the great National Educational Association meeting in July. Free hooks. W. C. Rinearson, G.P.A., Cincinnati.

## Don't Go Blind or Deaf!

### But Write DR. COFFEE, Des Moines, Iowa

For his 80-page book, telling all about his mild medicines that absorb Cataracts, White Spots, Blindness and all Eye Inflammation, Deafness and Head Noise, at Home. 13,000 patients cured last year. He can do for you what he did for these people, write to-day. Address 334 Good Block, Des Moines, Iowa.



W. O. COFFEE, M.D.

77 Years Old and Cured of Cataracts on Both Eyes: Too old to permit of an operation for being cured until she learned of Dr. Coffee's new method of curing cataracts—she travels from Aurora, Neb., to Des Moines, and has her sight restored perfectly—can see to read the finest print.

Des Moines, April 12, '99.

To Whom It May Concern—This is to certify that I am 77 years old; that I live in Nebraska, in the town of Aurora; that I commenced to lose my sight over one year ago from cataracts on both eyes, and, having a son, R. E. Hammond, living at 1510 24th street, Des Moines, Ia., I decided to visit him last fall and consult an oculist in Des Moines. He took me to Dr. W. O. Coffee, and I went under his treatment for the cure of cataracts by absorption, as I was too old to be operated on. I have carried on this treatment for nearly five months and yesterday he turned me off as perfectly cured. I can see as perfectly as I ever did, can thread a needle without glasses; and I want to say, to any one afflicted with cataracts of the eyes and blindness, that Dr. Coffee's new absorption method does cure them and that his terms are very moderate.

LUCINDA HAMMOND.

A Wonderful Cure of Deafness—It Required Thirteen Months—But He is Cured by the Home Treatment: Auburn, Sac Co., Iowa, Jan. 15, 1900. This is to certify that I am fifty-four years old, that I have lived in Sac Co. thirty years, that I commenced to get deaf and have trouble with my ears twelve years ago, and I have gradually got worse until I could not hear conversation or preaching or a watch tick. No treatment seemed to help me until I wrote to Dr. Coffee, at Des Moines, and began his home treatment. The first three months I did not seem to improve any at all, but, it being my only hope, I stuck to it, and I am thankful to say that my hearing is now almost perfect, my catarrh is cured, my rheumatism has all left me, and I seem to be in perfect health. I want to say to everybody that is deaf, if they will stick to Dr. Coffee's treatment he will cure them. Yours respectfully, THOS. GORMAN.

(Write quick before books are all gone.) Mention the Farm and Fireside.

## \$83.33 Monthly Salary

payable weekly with expenses. Men or Women to represent us in their own state. Your duties to take charge of solicitors and attend to collections. NO INVESTMENT REQUIRED. This is a strictly bona-fide salaried proposition. IT INVOLVES NO CANVASSING whatever. Expenses will be remitted in advance and salary forwarded directly from headquarters. State experience. Give references. Enclose stamp. CO-OPERATIVE CO., 410 Star Bldg., CHICAGO.

Brass Band Instruments, Drums, Uniforms, & Supplies. Write for catalog, 445 illustrations. FREE; it gives information for musicians and new bands. LYON & HEALY, 95 Adams St., CHICAGO.

FREE to First Applicants from Each Locality Choice of SILK WAISTS or PETTICOATS, BICYCLES, CAMERAS, WATCHES, GUNS, MACKINTOSHES, etc. Conditionally. A splendid opportunity. Send 25 cents for set of gold-plated HAIRY Waist or Skirt Pins, and we will send you an illustrated catalog with full particulars. Manufacturers Distributing Agency, Dept. F, Chicago, Illinois.

LADIES I Make Big Wages —AT HOME— and will gladly tell you all about my work. It's very pleasant and will easily pay \$18 weekly. This is no deception. I want no money and will gladly send full particulars to all sending 2c. stamp. HBS. A. H. WIGGINS, Box 20 Benton Harbor, Mich.

Corn removed free. Send postal for A-Corn Salve trial box of Giant Chemical Co., Philadelphia.

\$900 Salary and Expenses Guaranteed Energetic and trustworthy men and women to travel, appoint agents and make collections, for an old established corporation with \$200,000 capital. Unusual opportunity. Position permanent. Rapid promotion. "Universal," Lock Box 733, Phila. Pa.

\$2.75 buys a BEAD BODY and Baby Carriage \$5.00 buys a Beauty complete with rubber tire wheels and paragon. Full line of Sleeping Coaches and Go-Carts. 48 page Catalogue Free. Address Dept. 11 VICTOR MFG. CO. 161 to 167 Plymouth Place, CHICAGO, ILLINOIS.

FAMILY RECORD A beautiful picture; rich colors; background solid gold. Tremendous seller. Agents delighted. Sample free for 12 cents to pay postage and advertising, nine for \$1, post-paid. HOME ART PICTURE CO., Chicago, Ill.

## BEST EDUCATION

CHRISTIAN NON-SECTARIAN

NORTHERN advantages in Southern mountain climate, 130 miles from Cincinnati. Reduced railroad rates. College, Music, Academy, Normal, Manual. Incidental fee \$4.50 a term. The great expense in education is board. Go where board is furnished cheaply. No saloons.

Find out about BEREA COLLEGE

Address VICE-PRES. GEO. T. FAIRCHILD, LL.D., Berea, Kentucky

## Knickerbocker Special

AND South-Western Limited

Famous Trains Between

BOSTON, NEW YORK, WASHINGTON, CINCINNATI, CHICAGO, ST. LOUIS, VIA Big Four Route AND NEW YORK CENTRAL, BOSTON & ALBANY, CHESAPEAKE & OHIO.

Cafe, Library, Dining and Sleeping Cars.

W. J. LYNCH, W. P. DEPPE, Gen. Pass. and Tkt. Agt. Asst. G. P. and T. A. CINCINNATI, OHIO.

## TO THE AMERICAN SUMMERLAND

"The Overland Limited," VIA UNION PACIFIC

### ONLY THREE NIGHTS BETWEEN CHICAGO AND CALIFORNIA

"The Overland Limited" runs every day in the year and makes many hours quicker time between Missouri River and San Francisco than any other line. Finely equipped with Double Drawing-Room Palace Sleepers, Buffet Smoking and Library Cars, with Barber-Shop and Pleasant Reading-Rooms. Dining-Cars, Meals a-la-carte. Pintsch Light, Steam Heat. For tickets, advertising matter, and full information, call on or address A. G. SHEARMAN, Gen. Agt. Pass. Dept. U. P. R. Co. Room 36, Carew Bldg., Cincinnati, Ohio.

## FAT

How to Reduce it Mrs. L. Lanier, Martin, Tenn., writes: "I introduced my weight 2 lbs. in 15 days without any unpleasant effects whatever." Purely vegetable, and harmless as water. Any one can make it at home at little expense. No starving. No sickness. We will mail a box of it and full particulars in a plain sealed package for 4 cents for postage, etc. HALL CHEMICAL CO., Dept. B, St. Louis, Mo.

## Do You Suffer With PILES

Send us your name and address, and let us mail you our Booklet—"FACTS," about MERTANNO the only specific for the non-surgical treatment of PILES. Our Guarantee: We will refund the price paid for this remedy in any case of Piles it fails to relieve or cure. MERTANNO PHARMACAL CO., 422 Scott Street, Covington, Ky., U. S. A.

## RUPTURE

Sure cure at home; at a small cost. No operation, pain, danger or detention from work. No return of Rupture or further use for Trusses. A complete, radical cure to all (old or young). Easy to use; thousands cured; book free (sealed). DR. W. S. RICE, Box F, Adams, N. Y.

## ECZEMA

Facial Blemishes, Tetter, Salt Rhus, Barber's Itch, Scald Head, Ring Worm, Itching Piles, Sore Eyelids, and all Skin diseases promptly cured by Spencer's Ointment. Sent to any address on receipt of 25c. A. O. PILSON, Pharmacist, 1327 W. Baltimore St., Baltimore, Md.

## OPIUM

and Liqueur Habit cured in 10 to 20 days. No pay till cured. Write DR. J. L. STEPHENS CO., Dept. AS, Lebanon, Ohio.

## GOLDOMETER

In pocket case for hunting Silver, also Rods and Needles. Circular 2 cents. B. G. STAUFFER, Dept. F. F., Harrisburg, Pa.

## We Pay \$18 A WEEK AND EXPENSES

to men with rigs to introduce our Poultry Compound. Send stamp. Javelle Mfg. Co., Dept. 58, Parsons, Kan.

## ANGELS WHISPER

Beautiful Large Picture; colored. Sells quick at 25c. Sample 15c.; 9 for \$1. J. LEE, Omaha Bldg., Chicago.

## WANTED AGENTS

in every county to sell "Family Memorials;" good profits and steady work. Address Campbell & Co., 158 Plum St., Elgin, Ill.

## Coe's Eczema Cure \$1

at druggists. 25c. size of ns. COE CHEM. CO., Cleveland, O.

## BED-WETTING CURED.

Sample FREE. Dr. F. E. May, Bloomington, Ill.





**GOD LOVES THE MAN THAT MAKES US LAUGH**

The morbid man who wears a face  
Long as a mule's—his heastly brother—  
Who lets one chilling frown give place  
But only to present another;  
Who always is content to grope  
Along the path of care and bother  
And discount, can never hope  
To win the good-will of the Father.  
God has no use for solemn chaff,  
But loves the man that makes us laugh.

The sunshine of a merry smile,  
The music horn of rippling laughter,  
Are sent by heaven to beguile  
The tedious march to the hereafter.  
Their rays will pierce the darkest clouds  
And light them with a silver lining,  
Dispel the gloom that oft enshrouds  
The dreary lives of the repining.  
Fun's golden cup is sweet to quaff—  
God loves the man that makes us laugh.

We were not placed upon the earth  
To grovel in the dust of sorrow;  
To-day should always ring with mirth  
Without a thought of the to-morrow,  
And heaven has sent us cheery men  
To start and lead the merry chorus,  
To pierce with voice and pointed pen  
The earthly clouds that gather o'er us;  
To stab the gloom with humor's gaff—  
God loves the man that makes us laugh.

We stronger grow upon our feet,  
When foes of eluding care engage us,  
If in our daily walk we meet  
A man with smile that is contagious.  
His face lights up the darkened soul,  
As sunbeams pierce the veil of sadness,  
Adds sweetness to the bitter bowl,  
And makes the heartstrings thrill with glad-  
ness;  
Shows us the grain hid in the chaff—  
God loves the man that makes us laugh.  
—Denver Evening Post.

**HOME-LIFE**

ONE of the best services that most of us can render is to contribute all that in us lies to make our homes realize the ideal of what a home should be. And if every one did that, discordant and jarring families would speedily become little sections transplanted from paradise. It is not downright wickedness which does the most to make home-life unhappy, but thoughtlessness, self-centeredness, want of consideration and sympathy. We assume too much as due ourselves, instead of forgetting our own claims and being eager to give others more than they can claim. We live in the closest relations with members of our families year after year, and some mysterious power holds our eyes and we do not see their admirable traits; we take all sorts of self-sacrificing service from them as our due without appreciation. The side of an open grave into which a loved form is slowly lowered is a great revealer of life. The creaking cords and the heavy thud of the clod of earth upon the wooden box have a wonderful power of clearing away self-deceptions and adjusting a fine perspective of rights and duties. Only then it is too late.—Watchman.

**PASSING THE VISION ON**

One of Helen Hunt Jackson's poems tells of a singer who dwelt in the midst of low, level lands, but who walked ever by the sea, that he might catch a glimpse of the treasure-mountains that he was sure were somewhere in the distance. One day he saw them, but his fellow-townsmen called him mad when he attempted to point them out to them. Yet some were touched by his earnestness and

"One wistful gaze they also seaward took."

One morning he rowed out swiftly and steadily, to find the purple mountains that he saw gleaming on the horizon. He returned at nightfall and called joyfully to his fellows to help him unlade the treasure he bore—flowers, fruit and jewels. They saw no treasure, and passed on smiling. But some said:

"Alack, is he

"The madman? Have ye never heard there be Some spells which make men blind?"

And they watched him closely day by day, till they became convinced that there were hills and treasure for the seeking, and they sailed away to find them. Some found the mountains and came home laden with treasure, but others found nothing and were scornful.

A parable this of the inspiration which one soul may be to others when he has had his vision and follows it. Tennyson has given us another in the "Idylls of the King:" "Sir Percivale's sister has seen, in her cell, the vision of the Holy Grail. She tells the vision to Sir Galahad, and says to him:

"Go forth, for thou shalt see what I have seen,  
And break thro' all, till one will crown thee king  
Far in the spiritual city; and as she spake  
She sent the deathless passion in her eyes  
Thro' him, and made him hers, and laid her mind  
On him, and he believed in her belief."

—Christian Endeavor World.

**WAITING FOR THE VISION**

Before undertaking new work, Leonardo da Vinci often sat for days without moving his hand, lost in deep reflection. It was so when Filippino Lippi transferred to him an order for an altar picture in the monastery of a church. The complaint of the prior was of no avail. Without the vision of an ideal he would not lift brush to the canvas.

It was especially so in his great masterpiece, "The Last Supper." For days he awaited the moment when the face of Christ would be revealed to him in a manner worthy to represent his matchless perfection. The vision came, and all after-ages have been ennobled by its reproduction.

Native endowment and scholarly equipment are not adequate to the work of acquainting men with the life of God. As Da Vinci would not touch the canvas until the vision of Christ had flooded his soul, so every one who would communicate good to his fellow-men must first enrich his own life by the fullest possible discovery and appropriation of the Master's ideal.—The Sunday-school Times.

**WHY CHILDREN DISLIKE THE BIBLE**

The Rev. Edward Everett Hale says that the reason why so many young people and children do not like the Bible is because it is presented to them in a wrong way. They have erroneous views in regard to it. He believes that if treated as it ought to be young people would love it, and never wish to be through with it.

"This wonderful Hebrew literature," says Dr. Hale, "which has come down to us is our greatest blessing if rightly understood. The boy or girl who has been taught to separate part from part, who knows where is history, and where is poetry, and where is sympathy, and where to look for simply fact, that is the boy or girl who loves the book."

**A COMPENSATION OF TROUBLE**

How all along life we find it that they who are the kindest and tenderest and truest, who understand your trouble as by instinct, who minister that understanding, giving it, are they who, because of their own inner experiences, have acquired the gladdening, refreshing strength they bestow, the compensation God gives those who learn to get out of themselves, and feel and live for others.—J. F. W. Ware.

**HUMAN LOVE**

Human love is itself the best worship. Human love is itself the holiest presence of God, and is the best proof that the divine love which has produced it and lives in it will fulfill all the promises whispered there.—Henry W. Simons.

- ARMSTRONG & McKELVY Pittsburgh.
- BEYMER-BAUMAN Pittsburgh.
- DAVIS-CHAMBERS Pittsburgh.
- FAHNESTOCK Pittsburgh.
- ANCHOR Cincinnati.
- ECKSTEIN Cincinnati.
- ATLANTIC
- BRADLEY
- BROOKLYN New York.
- JEWETT
- ULSTER
- UNION
- SOUTHERN Chicago.
- SHIPMAN
- COLLIER
- MISSOURI St. Louis.
- RED SEAL
- SOUTHERN
- JOHN T. LEWIS & BROS CO Philadelphia.
- MORLEY Cleveland.
- SALEM Salem, Mass.
- CORNELL Buffalo.
- KENTUCKY Louisville.

**O**UR interests influence our opinions. The manufacturers of Mixed Paints and so-called White Leads may believe their mixtures are the best because it is greatly to their interest to do so. We believe that Pure White Lead is the best Paint and our belief is confirmed by hundreds of years of use, and the experience of practical painters everywhere.

**FREE** For colors use National Lead Company's Pure White Lead Tinting Colors. Any shade desired is readily obtained. Pamphlet giving full information and showing samples of Colors, also pamphlet entitled "Uncle Sam's Experience With Paints" forwarded upon application.

National Lead Co., 100 William Street, New York.

**THIN PEOPLE LISTLESS SLEEPLESS SALLOW SKINNED**

frequently chew and smoke immense quantities of tobacco and wonder all the time why they look so bad, feel so mean. Try under an absolute guarantee of benefit and final cure, or money refunded, the taking of a single box of

**NO-TO-BAC**

regulates tobacco using, builds up nervous system, makes pure rich blood. Many report a gain of ten pounds in ten days. Go buy a box. Try it under your own

**DRUGGIST'S GUARANTEE.** Every druggist is authorized to sell No-To-Bac under absolute guarantee to cure every form of tobacco using. Our written guarantee, free sample of No-To-Bac and booklet called "Don't Tobacco Spit and Smoke Your Life Away," mailed for the asking. Address THE STERLING REMEDY CO., Chicago, Montreal, Can., N. Y. 63

**CASCARETS** candy cathartic, cure constipation. Only 10c.

**\$3.50 A \$2500 Watch**  
in appearance. The handsomest genuine gold plated watch on the market. Double hunting case, **SOLID GOLD PATTERN** of engraving. Elegantly finished jeweled movement, stem wind and set and absolutely guaranteed for **20 YEARS**. Cut this out and send it to us with your name and address and we will send the watch to you by express for examination, you examine it at the express office and if as represented pay express agent our special introductory price \$3.50 and it is yours. Only one watch to each customer at this price. Mention in your letter whether you want **GENT'S OR LADY'S SIZE** and order to-day as we will send out samples at this reduced price for 60 days only. **R. E. CHALMERS & CO. 352-356 Dearborn St. Chicago.**



**Solid GOLD OR SILVER**  
plated Bracelet sent free to LADIES GOLD plated Dress with an exquisite jewel. (Sims) we will send you the pins post-money & we will send you the fully engraved & the lock opens trust you & will take back all to-day. **THE MAX WILHOFT CO**  
anyone for selling 5 sets of four Pins for 25c. a set (each pin set) send your name & address & paid. When sold, send us the Bracelet. The chain is beautiful with a dainty little key. We the pins you cannot sell. Write **DEPT. 657 St. Louis, Mo.**

**DR. F. WILHOFTS (ORIGINAL) LADY'S SYRINGE**  
THE ONLY PERFECT VAGINAL SYRINGE  
Its principle of action—that of **LINEATION** and **SUCTION**—assures a thorough cleansing. All in one piece of best soft rubber; always ready for instant use. Beware of Imitations. The only genuine has signature of **DR. F. WILHOFT** molded on each syringe. Accept no other, but write for **ILLUSTRATED BOOKLET** of "Useful Information for Women Only" **FREE.**  
**DR. F. WILHOFT,**  
571 Walton Ave., New York

**FREE! FREE!**  
This Beautiful **TURQUOIS** or **LOVER'S KNOT BANGLE RING.**  
Warranted three years, with initial engraved. Send 10c. for 16-page catalogue. The Shell Novelty Co., Dept. F.M., 194 Broadway, N. Y.

**AGENTS HAVE YOU SEEN IT?**

Here are a few specimen extracts from agents' letters the past week: "I had your order for 44 copies of Our Philippine Wonderland. The book takes splendidly." (Ohio.) "Have averaged two sales every hour I have been out, and certainly think Wonderland is the best and cheapest book in all my line of selling books." (Conn.) "Am more than pleased with Our Philippine Wonderland, and find it easy to sell. Have taken as high as ten orders in a single afternoon." (Ill.) "I am a girl of seventeen, and never sold a book before, but with Our Philippine Wonderland I have never made below \$3.00 a day, and on several days made \$4.00 to \$5.00." (Maine.) "Am busy delivering my 42 books, and will soon order again. I say again Our Philippine Wonderland is the most attractive and entertaining book I ever secured possession of." (Indiana.) "When I began work with Our Philippine Wonderland I never thought of such success. Have 70 orders already, and expect to double the list in a short time." (A minister in Iowa.)

**OUR PHILIPPINE WONDERLAND**

With Large Folding Map in Colors, reveals a new world to American readers. Lavishly illustrated with the finest of half-tones, it is the most striking book published this season. Its 105,000 words of reading matter rival in interest the most powerful novel. As the Philippine question is the leading question this year, nothing could be more timely. It is up to date and quite the most interesting and reliable work yet published on the Philippine lands and Philippine peoples. **PRICE VERY LOW.** Its remarkable sale is proceeding through canvassing agents exclusively, either ladies or gentlemen. We are the sole publishers, and some of the best fields are still open. For terms, territory, specimen illustrations and full particulars address **THE CROWELL & KIRKPATRICK CO., 1529 Marquette Building, Chicago, Ill.**

**WHERE TO LOCATE?**

Why, in the Territory Traversed by the ...

**Louisville and Nashville Railroad**

THE Great Central Southern Trunkline IN **Kentucky, Tennessee, Alabama, Mississippi, Florida**

WHERE **Farmers, Fruit-Growers, Stock-Raisers, Manufacturers, Investors, Speculators and Money-Lenders**

will find the greatest chances in the United States to make "big money" by reason of the abundance and cheapness of

**LAND and FARMS, TIMBER and STONE, IRON and COAL, LABOR--EVERYTHING!**

Free sites, financial assistance, and freedom from taxation, for the manufacturer. Land and farms at \$1.00 per acre and upwards, and 500,000 acres in West Florida that can be taken gratis under U. S. Homestead laws. Stock-raising in the Gulf Coast District will make enormous profits. Half fare excursions the first and third Tuesdays of each month. Let us know what you want, and we will tell you where and how to get it—but don't delay, as the country is filling up rapidly. Printed matter, maps and all information free.

ADDRESS **R. J. WEMYSS, General Immigration and Industrial Agent, LOUISVILLE, KY.**

**IN THE LAKE COUNTRY**

of Northern Illinois, Wisconsin, Minnesota, and Michigan there are hundreds of the most charming Summer Resorts awaiting the arrival of thousands of tourists from the South and East.

Among the list of near-by places are Fox Lake, Delavan, Lauderdale, Waukesha, Oconomowoc, Palmyra, The Dells at Kilbourn, Elkhart and Madison, while a little further off are Minocqua, Star Lake, Frontenac, White Bear, Minnetonka and Marquette on Lake Superior.

For pamphlet of "Summer Homes for 1900," or for copy of our handsomely illustrated Summer book, entitled "In The Lake Country," apply to nearest ticket agent or address with four cents in postage, Geo. H. Heafford, General Passenger Agent, Old Colony Building, Chicago, Ill.





WHEN THE BOER IS ON THE KOPJE

When the Boer is on the kopje and the laager's in the nek. Then we hear the hurried footsteps of the British as they trek; Then we read of valiant charges and of "sal-lies from the kloof," And the expert war reporters write of "bat-tle's stern reproof." Oh, the cable's full of messages about the rush and wreck When the Boer is on the kopje and the laager's in the nek. First there comes a thrilling message that the Boers are put to rout; Then a second message tells us that the battle is in doubt. Next a third one rather backwardly says, "Glorious retreat;" And the last one breaks it gently, thus, "An-other proud defeat." And across Tugela river go the British on the trek. While the Boer is on the kopje and the laager's in the nek. When the husky Boer has rested in the veldt or on the sprot, He will mark the psalm he's reading and begin again to shoot. He's a rapid-firing puzzle when he hides upon the krantz. And the enemy begins to think quite soon its name is "Pants." But the trap is set for trouble and excite-ment by the peck When the Boer is on the kopje and the laager's in the nek.

-Baltimore American.

THE RUSSIAN'S MISTAKE

A RUSSIAN complained to a reporter of a New York paper that "English" was a hard language to learn. But the story he told simply illustrated that he had not been trained to un-derstand what he read.

On the day after his arrival in London he made a call on a friend in Park Row, and on leaving the premises wrote down in his note-book what he supposed to be the exact ad-dress. The next day, desiring to go to the same place again, he called a cahman and pointed to the address that he had written down.

The cahman looked him over, laughed, cracked his whip, and drove away without him. This experience being repeated with two or three other cabmen, the Russian turned indignantly to the police, with no bet-ter results. One officer would laugh, another would eye him suspiciously, and another would tap his head and make a motion im-itating the revolution of a wheel.

Finally the poor foreigner gave it up, and with a great deal of difficulty recalling the landmarks which he had observed the day before, found his way to his friend's house.

Once there, and in company with one who could understand him, he delivered himself of a hot condemnation of the cabmen and police of London for their impertinence and dis-courtesy. His friend asked for a look at the mirth-provoking address, and the mystery was solved. This was the entry:

\* \* \* \* \* 546 \* \* \* \* \* RING THE BELL. \* \* \* \* \*

The Russian had, with great care, copied character for character the legend on the gate-post, supposing that it was the number of the house and the name of the street.

MISTAKEN

Wife (with a determined air)—"I want to see that letter!" Husband—"What letter?"

Wife—"That one you just opened. I know by the handwriting that it is from a woman, and you turned pale when you read it. I will see it! Give it to me, sir!" Husband—"Here it is. It's your milliner's bill."—Christian Advocate.

WHAT HE NEEDED

"My son," said the indulgent father, "is as good as wheat."

"Perhaps," replied the caudid friend of the family, who knew the young man better; "and like wheat he won't be thoroughly good without a thrashing."—Philadelphia Press.

HAD HIS SUSPICIONS

A tramp applied to a Boston woman the other day for something to eat, and was asked how a chop would suit him. He studied a moment and looked up suspiciously. "Mutton or wood-shed, lady?"

ADJOURNED BY REPORTERS

"Well, that humps me," said the Colonel, as he began fanning himself with a Panama hat. "I know that the cheek of these newspaper reporters is always in full flower, but I didn't know that they assumed to legis-late for the state."

"All I know is," asserted the Judge again, "that two newspaper reporters once ad-journed a session of the Illinois senate."

"How did they do it? Choke the speaker with copy-paper?"

"No; they were very civilized about it. It was one day when everybody expected a dull session, and only two of us senators put in an appearance, counting 'Dave' Littler, who was in the chair.

"I want to get an interview with Littler when this thing is over," said one newspaper man.

"So do I," said the other. "I move that we adjourn," he shouted at Littler.

"I second the motion," said the first re-porter.

"It is moved and seconded that we now adjourn," said Littler, solemnly. "Those in favor will signify it in the usual manner."

"Aye!" shouted both reporters.

"Carried!" said Littler."

PREDICTIONS OF PESTIFEROUS PROSPECTS FOR POTATO-PATCH CITY



Mrs. Potato-hug—"What are the weather probabilities for to-day?" Her husband—"Strong winds and heavy showers of Paris green."—Exchange.

HER EXACT WORDS

Housekeeper—"How's this? You promised to saw some wood if I gave you a lunch."

Tramp—"I recall no such promise, madam."

Housekeeper—"The idea! I told you I'd give you a lunch if you'd saw some wood, and you agreed."

Tramp—"Pardon me, madam. Your exact words were, 'I'll give you a lunch if you saw that wood over there by the gate.'"

Housekeeper—"Exactly. That's just what I said."

Tramp—"Well, madam, I saw that wood over there by the gate as I came in."—New York Weekly.

A DANGEROUS EPIDEMIC

Mama—"What is Willie crying about?" Nurse—"Sure, ma'am, he wanted to go across the street to Tommy Green's."

Mama—"Well, why didn't you let him go?"

Nurse—"They were having charades, he said, ma'am, and I wasn't sure as he had had 'em yet."

HER KNOWLEDGE OF COOKING LIMITED

Mrs. Youngwife—"I want to get some salad."

Dealer—"Yes, ma'am. How many heads?"

Mrs. Youngwife—"Oh, goodness, I thought you took the heads off! I just want plain chicken salad!"

THE ECONOMY OF IT

Isaacs—"I hear you are trying to change your name to 'Rose.' I hope you are not ashamed of your race?"

Rosenstein—"Soit'nly not. But vat is de use of vasting all dot ink?"

A BARE POSSIBILITY

"He said he'd sign the paper, but every time I put it under his nose he has some excuse."

"Perhaps the gentleman does not write with his nose."—Judge.

CHARLESTON-BY-THE-SEA

National Educational Association, Charleston, S. C., July 7th-13th. Low rates Queen and Cres-cent Route and Southern Railway. Write for free books to W. C. Rinearson, G. P. A., Cincinnati.

The Peerless Pictures

ON HEAVY ART-PAPER 20 BY 25 INCHES IN SIZE

Any THREE of the Pictures Listed Below Given as a Reward for Sending Two Yearly Subscriptions (new or renewal) to the Farm and Fireside.

ANY ONE OF THE PICTURES LISTED BELOW, AND THE FARM AND FIRESIDE ONE YEAR, FOR 35 CENTS. . . . .



No. 796 THE HORSE FAIR Size 18 by 28 inches

SIZE The Peerless series of pictures, including the margins, are 20 by 25 inches in size. Without the margins they are about 16 by 20 inches, varying somewhat according to the subject.

STYLE These pictures are reproduced in the very latest and most tasty style. They are not cheap chromos or attempts at color reproduction, which usually bear no resemblance to the originals.

Grand Reproductions of Famous Paintings

- IMMACULATE CONCEPTION . . . Painted by Murillo . . . Prem. No. 784
PHARAOH'S HORSES . . . Painted by Herring . . . Prem. No. 785
QUEEN OF FLOWERS . . . Painted by Lefler . . . Prem. No. 786
AFTER WORK . . . Painted by Holmes . . . Prem. No. 787
CHRIST BEFORE PILATE . . . Painted by Munkacsy . . . Prem. No. 788
DEFIANCE, or STAG AT BAY . . . Painted by Landseer . . . Prem. No. 789
KISS ME (Child and Dogs) . . . Painted by Holmes . . . Prem. No. 790
THE LITTLE SHEPHERDESS . . . Painted by Koller . . . Prem. No. 791
PORTRAIT OF WASHINGTON . . . Painted by Stuart . . . Prem. No. 792
THE FINDING OF MOSES . . . Painted by Schopin . . . Prem. No. 793
CAN'T YOU TALK . . . Painted by Holmes . . . Prem. No. 794
WATERFALL BY MOONLIGHT . . . Painted by Rieger . . . Prem. No. 795
THE HORSE FAIR . . . Painted by Bonheur . . . Prem. No. 796



No. 785 PHARAOH'S HORSES Size 20 by 25 inches

This is the first time that faithful copies of the world's greatest works of art have been reproduced so they could be offered on such popular terms.

We Will Send the Farm and Fireside One Year and Any Two of These Pictures for 50 Cents

(When this offer is accepted the club-raiser may have either the regular cash commission or the name may be counted in a club)

FREE Any THREE of these Pictures, Your Choice, Given as a Pre-mium for TWO Yearly Subscriptions to the Farm and Fireside.

The pictures will be sent by mail, securely packed and postage paid. Entire satisfac-tion guaranteed. A beautiful twelve-page circular giving illustrations and descriptions of the paintings sent FREE on request. Write to-day.

Postage paid by us Address FARM AND FIRESIDE, Springfield, Ohio



# A GREATER BARGAIN THAN EVER

**T**HE price of silver-plated ware is steadily advancing, and yet we are furnishing this ware at the former prices. At these prices it is the biggest bargain at present offered in high-grade silver-plated ware. This ware can be used in cooking, eating and medicines the same as solid silver; it will not, cannot turn brassy, corrode or rust. In beauty and finish it is perfect. The only way in which we are able to offer this ware at such bargains is that we have it manufactured especially for us in enormous quantities, and handle it entirely without profit to get subscriptions and clubs. All of the ware is full regulation size.

## Pure Coin-silver Plating . . . . .

The base of this ware, except the table-knives, is solid nickel-silver metal, which is the best white metal known for the base of silver-plated ware, because it is so hard and so white that it will never change color and will wear for a lifetime. The base of all this silverware is plated with the full STANDARD amount of pure coin-silver.

The base of the table-knives is fine steel highly polished. They are first plated with nickel-silver, which is as hard as steel, then plated with 12 penny-weights of coin-silver. There are no better silver-plated knives on the market. They are fully warranted.

## Will Stand Any Test . . . . .

To test this silverware use acids or a file. If not found to be plated with the full STANDARD amount of pure coin-silver and the base solid white metal, and exactly as described in every other particular, we will refund your money and make you a present of the subscription. If returned to us we will replace free of charge any piece of this ware damaged in making the test.



### FROM MANUFACTURER TO USER

There is no middleman's profit added to the price of this ware, as we are satisfied to handle it without profit to get subscriptions and clubs, and pass it from the manufacturer to the user at manufacturer's cost plus the expense of postage and wrapping. In this way our subscribers get this ware at less than one half the usual price for a similar grade of goods. It is of first-class quality.

### WEAR PROVES ITS QUALITY

We have handled this ware for years and have sent it into many thousands of homes, where it is now rendering general satisfaction. Hundreds of thousands of pieces of it have been sent out, covered by our guarantee, and complaints are practically unknown. We have thousands of testimonials as to its wearing qualities. A trial order is sure to be followed by others until you get the whole set.

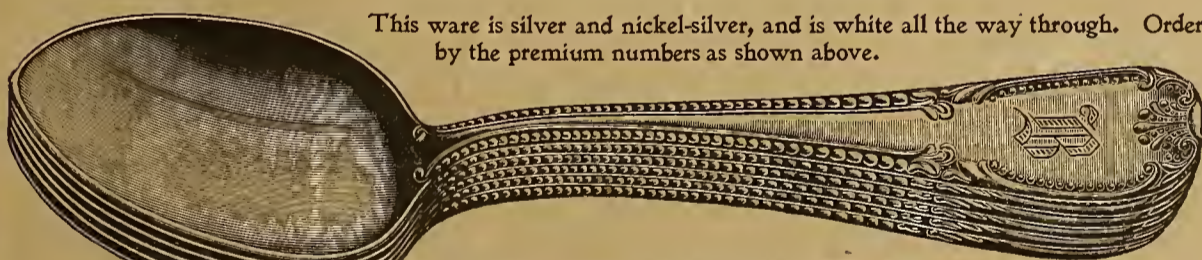

This ware is silver and nickel-silver, and is white all the way through. Order by the premium numbers as shown above.

This cut shows the ACTUAL SIZE of the Teaspoons, all the other ware being large in proportion.

**ANY INITIAL LETTER** Each piece of this ware (except the knives) engraved free of charge with an initial letter in Old English. Only one letter will be engraved on each piece. State your choice.

**GUARANTEE** We absolutely guarantee every piece of this ware to be exactly as it is described and to give full and entire satisfaction or money cheerfully refunded.

## PREMIUM OFFERS

We will send the Farm and Fireside one year and the Silverware at these prices:

- The Farm and Fireside 1 year and a Set of 6 Teaspoons for . . . \$ .75
- The Farm and Fireside 1 year and a Set of 6 Forks for . . . . . 1.25
- The Farm and Fireside 1 year and a Set of 6 Tablespoons for . . . 1.25
- The Farm and Fireside 1 year and a Set of 6 Knives for . . . . . 1.75
- The Farm and Fireside 1 year and a Set of 6 Coffee-spoons for . . . . . .75
- The Farm and Fireside 1 year and a Set of 6 Dessert-spoons for . . . 1.00
- The Farm and Fireside 1 year and a Set of 6 Dessert-forks for . . . 1.00
- The Farm and Fireside 1 year and Berry-spoon for . . . . . .65
- The Farm and Fireside 1 year and Pie-knife for . . . . . .65
- The Farm and Fireside 1 year and Gravy-ladle for . . . . . .65
- The Farm and Fireside 1 year and Child's Set (Knife, Fork and Spoon) for . . . . . .60
- The Farm and Fireside 1 year and Butter-knife and Sugar-shell (both) .60

(When any one of the above offers are accepted the club-raiser may have either the regular cash commission or the name may be counted in a club)

## SILVERWARE FREE

For Clubs of Subscriptions to the Farm and Fireside

- Set of 6 Teaspoons given free for a club of four subscriptions
- Set of 6 Forks given free for a club of six subscriptions
- Set of 6 Tablespoons given free for a club of six subscriptions
- Set of 6 Knives given free for a club of twelve subscriptions
- Set of 6 After-dinner Coffee-spoons given free for a club of four subscriptions
- Set of 6 Dessert-spoons given free for a club of six subscriptions
- Set of 6 Dessert-forks given free for a club of six subscriptions
- One Berry-spoon given free for a club of four subscriptions
- One Pie-knife given free for a club of four subscriptions
- One Gravy-ladle given free for a club of four subscriptions
- One Child's Set (Knife, Fork and Spoon) given free for a club of four subscriptions
- Sugar-shell and Butter-knife (both) given free for a club of four subscriptions

(The following note gives instructions how to take subscriptions in clubs)

NOTE—Thirty-five cents is the clubbing price for yearly subscriptions to the Farm and Fireside without a premium to the subscriber. And members of clubs may accept any of our premium offers at the advertised prices and their names can be counted in clubs (unless otherwise stated in the advertisement). RENE WALS and new names, including a club-raiser's own subscription, can be counted in clubs. No reduction allowed in the clubbing prices.

Postage or expressage paid by us in each case

Address FARM AND FIRESIDE, Springfield, Ohio



# Remainder = of = the = Year Offers

The Farm and Fireside From Now Until January 1, 1901,  
and Any One of the Following Valuable Premiums for

# 25c.

## The Arts Of Beauty

BY THE  
NOTED AUTHOR;  
**SHIRLEY  
DARE**

**T**HE writer has had many exceptional opportunities to gather the information she has so wisely and compactly accumulated in her volume, "The Arts of Beauty," which we now offer in this unparalleled premium collection. The book is specifically a text on physical beauty and personal charm, and should be read by every girl and woman, especially by every mother who is raising daughters. It teaches not only what to do, but what not to do as well. It describes only such remedies and methods as are perfectly safe, and is fully indorsed by physicians.

OVER 250 BEAUTIFUL PAGES

**THE AUTHOR** Shirley Dare is one of the most popular and practical writers in America on cosmetics, health and the arts of the toilet. She has made the subject her life-work, having studied under the best masters in this country and Europe. What she says in "The Arts of Beauty" regarding the care of the complexion, hair, body and health in general may be relied upon as authority. **Premium No. 63.**

SOME OF THE CHAPTER HEADINGS

I. GIFTS OF CHARMING	IX. TOILET ELEGANCIES
II. THE SECRET OF GOOD LOOKS	X. MANICURING
III. GRACE AND EXPRESSION	XIII. DEFECTS and ANNOYANCES
VI. TRAINING FOR A FINE FIGURE	XV. HEALTH and DRESS
VIII. THE CULTURE OF BEAUTY	XIX. DIET FOR BEAUTY and HEALTH

**THE ARTS OF BEAUTY** has heretofore been sold by agents at never less than \$1.50 a copy. We have arranged, however, to offer this valuable book in this unprecedented premium collection, without reserve. *Satisfaction guaranteed.*

We Will Send The Arts of Beauty, and the Farm and Fireside Six Months, for . . . **25 Cents**

(When this offer is accepted two six-months' subscriptions may count in a club the same as one yearly subscription)

## The Standard American Cook Book . . . .

Premium No. 10

**T**HIS Cook Book contains thousands of the most valuable recipes and desirable formulas by noted experts and over two hundred practical housekeepers. It covers every branch of cookery, with special directions for serving at table; also preserving, pickling, candy-making, etc., and ten more chapters of helps.

**THIS IS THE COOK BOOK YOU WANT**

Because its plan includes the valuable and useful points of other cook books, and in addition it has inestimable features of its own entirely new. For regular use it will give you the best of satisfaction as a clear, safe, reliable, economical kitchen guide, with an abundance of good things. It far surpasses all others.



PASTRY POTATOES

**250 Object-Teaching Illustrations**

Making clear at a glance important processes in plain and fancy cooking. To show HOW a thing should be done amounts to far more practically than any mere bidding do it. Once accustomed to the pictorial object-teaching methods of this thorough and comprehensive work, no lady will be willing to go back to the unsatisfactory directions of other cook books. This Cook Book has a complete index.

We Will Send the Standard American Cook Book, and the Farm and Fireside Six Months, for . . . **25 Cents**

(When this offer is accepted two six-months' subscriptions may count in a club the same as one yearly subscription)

## TWO FUNNY BOOKS

**SAMANTHA AT SARATOGA**  
Premium No. 34

**SAMANTHA AMONG THE BRETHREN**  
Premium No. 55



ONE OF THE ILLUSTRATIONS FROM "SAMANTHA AMONG THE BRETHREN" (GREATLY REDUCED)

"SAMANTHA AT SARATOGA; or 'RACIN' AFTER FASHION," was written under the inspiration of a summer season 'mid the world of fashion at Saratoga, the proudest pleasure resort of America. The book takes off Follies, Flirtations, Low-necked Dressing, Dudes, Pug-dogs, Tobogganing, and all the extremes of fashionable dissipation, in the author's inimitable and mirth-provoking style.

"SAMANTHA AMONG THE BRETHREN; or, THE UPHOLD-IN' OF THE MEETIN'-HOUSE" was written to exhibit the comic side of the men's argument against women "a-settin' on the conference," and she does it to perfection.

Over 100,000 copies of each of these books, in expensive binding, were sold for \$2.50 a copy. We here offer special premium editions of these two famous books, which contain every word and every picture the same as in the \$2.50 edition. Size of each page, 5½ by 7½ inches. Children and grown-up people alike read with rapturous delight these two Samantha books. They are written in a vein of strong common sense, and are the truest of humor.

OVER 200 COMIC PICTURES

Comic illustrations are the fun-makers for the eyes, and these two books contain more than 200 pictures, most of them full-page size, similar in character to the one shown here. Merely to see them is to laugh. We guarantee satisfaction or promptly refund your money.

We Will Send Either One of the Samantha Books, and the Farm and Fireside Six Months, for . . . **25 Cents**

(When this offer is accepted two six-months' subscriptions may count in a club the same as one yearly subscription)

## GEMS FROM THE POETS

A CHARMING BOOK CONTAINING 400 POEMS AND PICTURES  
THE CREAM OF POETICAL LITERATURE

Premium No. 26

**T**HIS work contains a discriminating collection of what may be considered Gems from all the poets. Only representative productions are used, and as a result we have the very highest class of literature. It contains choice poems for all moods, all occasions, and will surely please every one. It is the only low-priced collection of poems fully illustrated. The designing and engraving of the illustrations alone cost at least \$20,000. The pages are large—7½ by 10 inches—and the book is large in proportion. The work contains an interesting collection of portraits and biographies of popular poets.

Partial List of Authors Represented

- |           |            |
|-----------|------------|
| WHITTIER  | SCHILLER   |
| BRYANT    | SHAKSPERE  |
| RILEY     | LONGFELLOW |
| SWINBURNE | POE        |
| DANTE     | BURNS      |
| TENNYSON  | MOORE      |
| MILTON    | HOOD       |
| ANGELO    | SHELLEY    |
| POPE      | WORDSWORTH |

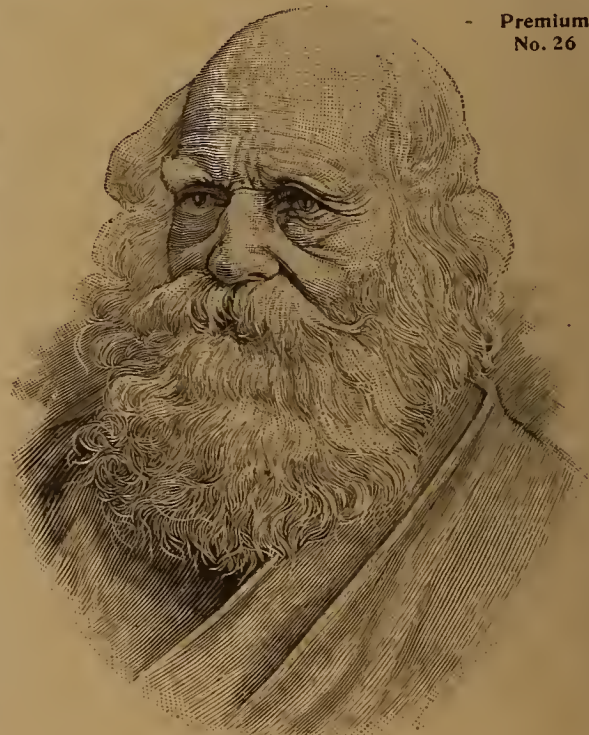

William Cullen Bryant

No Surer Source of Satisfaction or Better Value Has Ever Been Offered to Subscribers Than This Great Book

We Will Send Gems From the Poets, and the Farm and Fireside Six Months, for . . **25 Cents**

(When this offer is accepted two six-months' subscriptions may count in a club the same as one yearly subscription)

Order by the premium numbers  
Postage paid by us

Address FARM AND FIRESIDE, Springfield, Ohio



# Remainder=of=the=Year Offers

For  
**25**  
Cents

The Farm and Fireside from Now Until  
January 1, 1901, and Any One of the Val-  
uable Premiums Shown on This Page

For  
**25**  
Cents

## Pictures From All Countries

**300 LARGE  
PICTURES**

Of People, Places and  
Points of Interest From  
All Parts of the World

**Beautiful  
Pictures  
From All  
Parts of  
the World**  
  
**SPECIAL  
LIMITED  
OFFER**

Order by Premium No. 18

**A** BOOK of Scenes and a Book of Travel, as each picture has with it a description giving a full explanation of the same. Many points not covered by ordinary books of travel are contained in this. In fact, the aim has been to select the most unique and most representative features of the various countries, and to avoid those things which the ordinary book is likely to describe. This great work constitutes an unequalled aid to the study of geography and history.

### A MARVEL IN COST AND BEAUTY

The engravings in this book cost nearly \$30,000.00 to produce. They were designed to illustrate a very extensive work to be sold at \$60.00. It contains pictures of Cities, Cathedrals, Palaces, Capitols and Public Buildings, Bridges, Battlefields, Mountains and Ocean Scenery. As you turn its pages you imagine yourself a veritable globe-trotter, visiting strange people in foreign countries and gazing with admiration upon many of the most magnificent formations of nature and the most noted and marvelous structures reared by man in all ages.

We have only a few hundred copies of this great work left which we are going to give to the subscribers to the Farm and Fireside upon the following terms:

We Will Send Pictures From All Countries, and the Farm and Fireside Six Months, for **25 Cents**

*(When this offer is accepted two six-months' subscriptions may count in a club the same as one yearly subscription)*

## IN HIS STEPS

"WHAT WOULD JESUS DO?"

BY REV. CHARLES M. SHELDON

**T**HE most widely read book of the century. Other books have been sold by the hundreds of thousands and were considered remarkably successful, but this book has been sold by the millions. The story was written by the Rev. Charles M. Sheldon, of Topeka, Kansas, and read by the author, a chapter at a time, to his Sunday-evening congregation in the Central Congregational Church of that city. Having been put in book form its sale has been world-wide, several millions of copies having been sold.

The story has been warmly welcomed by Endeavor societies, temperance organizations, Young Men's Christian Associations, and Christian organizations as a great incentive to right living.

### HAVE YOU READ IT?

If not, you certainly should do so, as it is one of the most remarkable works ever produced. The copy we offer is the regular authorized edition, full and complete, printed on good paper and well bound in substantial paper cover.



Premium No. 45

We Will Send This Book, and the Farm and Fireside Six Months, for **25 Cents**

*(When this offer is accepted two six-months' subscriptions may count in a club the same as one yearly subscription)*

## GLEASON'S HORSE BOOK

EVERYTHING ABOUT THE HORSE

**P**ROF. GLEASON is renowned throughout America as the most expert and successful horse-trainer of the age. For breaking colts, conquering vicious horses and training horses he is a perfect wonder. His methods are simple and sensible, and can be put into use by any young man on the farm. To any one who has colts to break this book is worth many times the price we ask for it. This book is used by the United States cavalry as the one great authority on horse-training.

OVER 400 PAGES AND 130 ILLUSTRATIONS

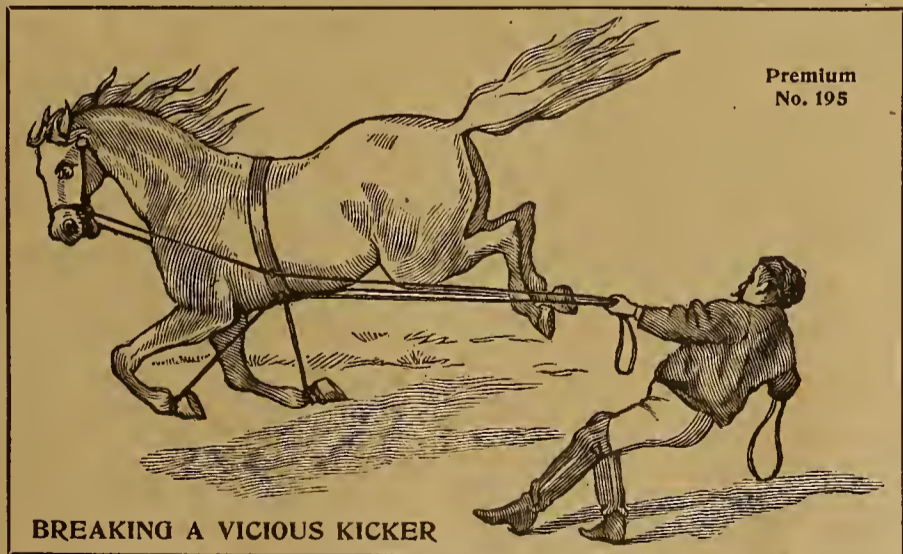

Premium No. 195

### A SYNOPSIS OF THE BOOK'S CONTENTS

History of the Horse; Educating the Horse; Teaching Horses Tricks; How to Buy; How to Feed, Water and Groom; Breeding and Raising Horses; Breaking and Taming Vicious Horses; Methods of Detecting Unsoundness; The Teeth; Horseshoeing; Diseases of the Horse.

We Will Send This Book, and the Farm and Fireside Six Months, for **25 Cents**

*(When this offer is accepted two six-months' subscriptions may count in a club the same as one yearly subscription)*

## NEW PEOPLE'S ATLAS OF THE WORLD

REVISED AND UP TO DATE  
THE FOLLOWING MAPS HAVE JUST  
BEEN ADDED

**NEW FULL-PAGE MAP OF SOUTH AFRICA**, showing all the war and railroad points. This new map throws a flood of light on the daily dispatches, making every movement of the contending forces entirely clear. It accurately locates Ladysmith, Kimberley, Mafeking, Bloemfontein and Pretoria, also Durban, Lorenzo Marquez on Delagoa Bay, and all the other ports and places constantly mentioned in connection with the Transvaal war.

**DOUBLE-PAGE MAP OF THE PHILIPPINES**, size 19x12 3/4 inches. Showing the entire theater of military operations and garrisoned points. Exhibits the exact boundaries of the Philippines as defined in the Treaty of Peace with Spain.

**CHINA AND THE FAR EAST**. New full-page map, indicating what ports have been occupied by the British, Russian, German, French and Portuguese governments respectively, and showing the relation of the Philippines to the mainland.

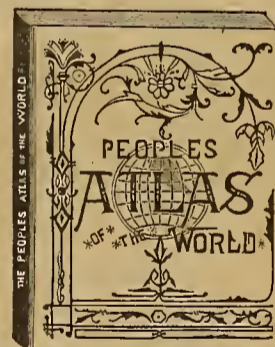

Miniature Cut of Atlas; Actual Size 11x14 inches.

Premium No. 11

NEW PEOPLE'S ATLAS CONTAINS 250 MAPS AND ILLUSTRATIONS

It contains 143 pages (each page is 11 inches wide and 14 inches long) and should be in every home and school-room. It is up to date; it is complete; it is educational; it is cheap.

It gives the population of each state and territory, of all counties in the United States, of American cities, by the last census. The excellent maps of all the states and territories in the Union are all large, full-page, and a number of double-page maps to represent the most important states of our country.

THERE ARE ALSO DOUBLE-PAGE MAPS OF CUBA AND ALASKA

All countries on the face of the earth are shown. Rivers and lakes are accurately located. All the large cities of the world, the important towns and most of the villages in the United States are given on the maps. It gives a classified list of all nations, with forms of government, geographical location, size and population.

We Will Send the New People's Atlas, and the Farm and Fireside Six Months, for **25 Cents**

*(When this offer is accepted two six-months' subscriptions may count in a club the same as one yearly subscription)*

Order by the premium numbers  
postage paid by us

Address **FARM AND FIRESIDE, Springfield, Ohio**



# FARM SELECTIONS

## POULTRY-YARD NOTES

CARE and feed are more important than breed.

A turkey requires no more feed than a Brahma.

The more digging the more eggs. Moral: Keep the hens digging.

Green grass, young clover and insects will color the yolk of eggs as spring pasture tints butter. In a similar manner color can be put into eggs of yarded hens by feeding greens and meat.

Count your hens, and every day keep a record of the eggs they lay, and at the end of the year you will have at your command valuable information. While you are about it note also each week the price of eggs and the number sold.—Farm Journal.

## RECENT PUBLICATIONS

### BOOKS NOTICED

**BELGIAN HARE BREEDING.** A practical treatise on rearing Belgian hares. By J. W. Darrow. Price 25 cents. Published by the "Fancier's Review," Chatham, N. Y.

**THE JURY TRIAL OF 1900.** In the court of public opinion. Bryan versus McKinley. The people's cause presented in crisp, sparkling argument by the leading men of the day. By Joseph R. McLaughlin. Published by Laird & Lee, Chicago, Ill.

**LET THERE BE LIGHT.** The story of a working-men's club, its search for the causes of poverty and social inequality, its discussions, and its plan for the amelioration of existing evils. By David Lubin. Published by G. P. Putnam's Sons, New York.

**HISTORY OF OHIO AGRICULTURE.** A treatise on the development of the various lines and phases of farm-life in Ohio. By Professor Charles W. Burkett. Cloth bound. Illustrated. 220 pages. Price \$1.50. Published by the Rumford Press, Concord, N. H.

**AMERICAN SHORT-HORN HERD BOOK.** VOLUME 44. Containing pedigrees of 4,042 bulls and 6,871 cows received between December 1, 1898, and April 1, 1899. Cloth bound. 1113 pages. Price, post-paid, \$3.30. J. H. Pickrell, Secretary American Short-horn Breeders' Association, Springfield, Ill.

**FORAGE AND FODDERS.** A practical discussion of the production, uses and values of various pasture and fodder plants, especially those found best suited to the purposes of Kansas farmers and stock-growers—treated under the one general term "Grass," and from the standpoint that "all flesh is grass." The March quarterly report (1900), Kansas State Board of Agriculture. F. D. Coburn, Secretary, Topeka, Kan.

### CATALOGUES RECEIVED

Chicago Flexible Shaft Co., Chicago, Ill. Illustrated circular of power sheep-shearing machines.

Kalamazoo Carriage and Harness Mfg. Co., Kalamazoo, Mich. Illustrated catalogue of vehicles and harness sold direct from factory to customers.

B. A. McAllaster, Land Commissioner, Omaha, Neb. Descriptive pamphlet of grazing-lands for sale by the Union Pacific Railroad Company.

Belle City Manufacturing Co., Racine Junction, Wis. Illustrated catalogue of the Columbia threshers and horse-powers, feed and ensilage cutters, tread-powers, root-cutters, etc.

Kansas City Hay Press Co., Kansas City, Mo. Memorandum-book illustrating Lightening hay-press, scales, stump-pullers, feed-mills, hay-loaders and stackers, power shellers, gasoleue-engine, etc.

## FARM WAGON ONLY \$21.95

In order to introduce their Low Metal Wheels with Wide Tires, the Empire Manufacturing Company, Quincy, Ill., have placed upon the market a Farmer's Handy Wagon that is only 25 inches high, fitted with 24 and 30 inch wheels with 4-inch tire, and sold for only \$21.95.

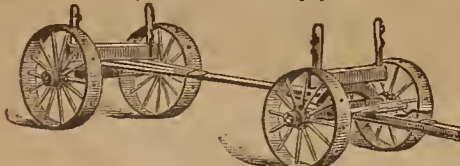

This wagon is made of the best material throughout, and really costs but a trifle more than a set of new wheels, and fully guaranteed for one year. Catalogue giving a full description will be mailed upon application by the Empire Manufacturing Co., Quincy, Ill., who also will furnish metal wheels at low prices made any size and width of tire to fit any axle.

## THE QUEEN AND CRESCENT

Route makes low rates to Charleston, S. C., for the great meeting of the National Educational Association July 7th-13th. Write W. C. Rinearson, G.P.A., Cincinnati, for particulars.

# The M<sup>c</sup>CORMICK VERTICAL CORN BINDER

is the only Corn Binder made that will cut and bind corn under all the unfavorable conditions in which the corn is found at cutting time.

It will cut and bind BIG CORN, LITTLE CORN, DOWN CORN, LODGED CORN or any other kind of corn that grows in rows

It makes tight bundles of convenient size and the corn can be husked by hand without untying bundles or it can be husked and the fodder shredded by the M<sup>c</sup>Cormick Husker & Shredder CALL ON THE M<sup>c</sup>CORMICK AGENT.



## No. 58 Handy Buckeye Cultivator

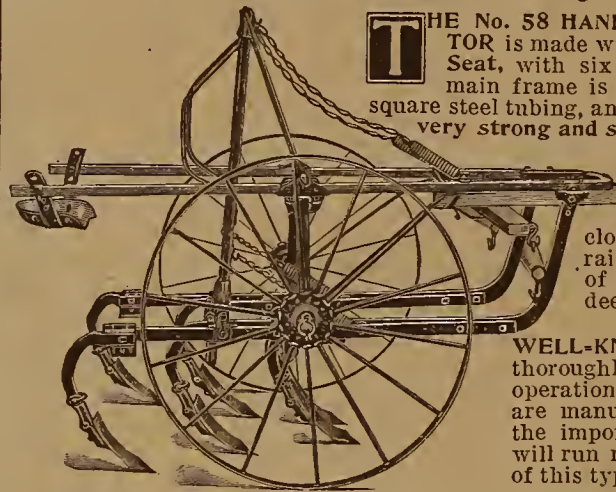

THE No. 58 HANDY BUCKEYE RIDING CULTIVATOR is made with Pendulum Beam and Hammock Seat, with six small shovels, pin shovel. The main frame is bent "U" shape and is made of square steel tubing, and is in One Piece, which makes it very strong and simple.

The axle is adjustable, so that the machine can be narrowed or widened as desired, and has single tongue. The shovel standards can be set closer together or wider apart, and raised or lowered for the cultivation of corn or cotton that is planted in deep furrows or ridges.

This Cultivator is BUILT ON WELL-KNOWN PRINCIPLES which are thoroughly established by years of practical operation on Cultivators of this type, and are manufactured under patents covering the important features, so that customers will run no risk in purchasing Cultivators of this type from us. Manufactured by

P. P. MAST & CO., No. 17 Canal St., Springfield, Ohio, Philadelphia, Pa.

## Deal with the Makers



No. 3034 Buggy. Price \$39.30 with leather quarter top.

When you buy a carriage, buggy or harness. Choose from the biggest stock and fullest assortment, and pay only the cost of making, with but one moderate profit added. Our plan of selling direct from the factory insures satisfaction—your money back if you're dissatisfied with your purchase—and enables you to

save the dealer's profit.

Our complete illustrated catalogue, showing many styles of high grade vehicles, harness, robes, blankets and horse equipments, with detailed descriptions of each, mailed free. Write for it and learn how cheaply you can buy when the jobber's and dealer's profits are cut off.

THE COLUMBUS CARRIAGE & HARNESS CO., P. O. Box 772, Columbus, O.



No. 240 Single Strap Buggy Harness. Price \$2.15.



## FOR SELLING OUR JEWELRY NOVELTIES.

Watches, Cameras, Bracelets, Gold Rings, given away ABSOLUTELY FREE for selling our Jewelry. No money required. Send us your name and full address on a postal card, and we will send you 18 gold plate scarf and stick pins, all set with different colored stones, to sell for 10 cents each. The best sellers offered by any firm. When you have sold them we will send you your choice of a Watch, a solid Gold Ring and any other valuable premium on our large illustrated list, which we send you with the pins. We pay all postage.

NOVELTY MFG. CO., 82 Bailey St., Attleboro, Mass.

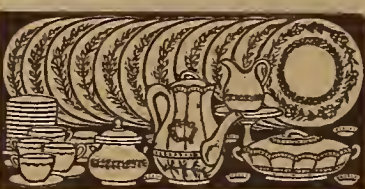

## 144 PIECE FREE DINNER SET

Full size for family use, beautifully decorated & most artistic design. A rare chance. You can get this handsome dinner set and one dozen fine plated tea spoons for selling our Pills. We mean what we say & will give this beautiful dinner set absolutely free if you comply with the extraordinary offer we send to every person taking advantage of this advertisement. To quickly

Introduce our Vegetable Pills, a sure cure for constipation, indigestion & torpid liver, if you agree to sell only six boxes of Pills at 25 cts. a box write to-day and we send Pills by mail, when sold send us the money & we send you one dozen plated tea spoons together with our offer of a 144 piece dinner set same day money is received. This is a liberal inducement to every lady in the land & all who received the spoons & dinner set for selling our Pills are delighted. AMERICAN MEDICINE COMPANY, DEPT. G, 32 WEST 13th STREET, NEW YORK CITY.

## WANT A WATCH?



You can secure a valuable watch absolutely free. Send us your name and address and we will send you by return mail your endless-chain ticket and ten tickets which you are to sell to your friends for 15 cents each, remit the \$1.50 to us, with the names and addresses to whom you sell, and we will send them a supply of tickets like those sent you. When your chain is completed (usually 2 to 3 weeks) we will send a watch of your own selection FREE. Watches guaranteed value \$15. No lottery. Square dealing guaranteed. Address

BOYLSTON & BENT, Rochester, N. H.

## 12 PAIRS OF STOCKINGS & SOCKS for 10c



JUST THINK OF IT! ONE DOZEN Pairs of LADIES' or CHILDREN'S STOCKINGS or MEN'S SOCKS, assorted as desired in any size, FOR LESS THAN ONE CENT A PAIR, which if bought in the stores would cost you from 25 cents to 75 cents per pair. For full particulars address

THE PEOPLE'S SUPPLY CO., Dept. 46, Wilkes-Barre, Pa.



## FENCE HONESTY

An honest way to sell anything is to have those who would buy, TRY IT. All we ask for the Duplex Machine is A TRIAL. With it you can make over 100 Styles at the actual cost of the wire. Catalogue and particulars free.

KITSELMAN BROTHERS, Box 278 Ellettsville, Indiana, U. S. A.

## BALE YOUR HAY

It will keep better, sell better and save room. Rats and mice can't cut and destroy baled hay. The best and most rapid machine for baling purposes is

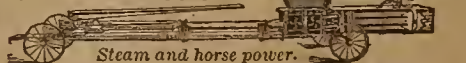

Steam and horse power. "ELI" BALING PRESS. Made in 33 styles and sizes to suit every case. All steel, light, strong, lasting. Write for free illustrated catalogue. COLLINS PLOW CO., 1116 Hampshire St., QUINCY, ILL.



## The NATIONAL EDUCATIONAL ASSOCIATION

MEETS THIS YEAR AT CHARLESTON, SOUTH CAROLINA, JULY 7-13

The famous old city will extend its broadest hospitality. The railroads announce low rates. This convention by the seaside is going to be the greatest meeting ever held by the N. E. A. One fare for round trip via Cincinnati and the

## Queen and Crescent

Route (plus \$2.00 membership). Stop-over privileges. Choice of routes and the best service that is to be found anywhere.

Write for free illustrated literature concerning Charleston and the way to get there.

W. C. RINEARSON, G. P. A. CINCINNATI, OHIO

## AGENTS WANTED

FOR THE ENLARGED 1900 PEERLESS ATLAS AND PICTORIAL GAZETTEER OF ALL LANDS...

Now ready. Over 800 Colored Maps and Beautiful Illustrations from Photographs. Sells at sight, the superb NEW FEATURES including War Map of South Africa, illustrated account of the Boers, Large Folding Maps of the Philippines, Pacific Ocean, Cuba, Alaska. Map and account of Nicaragua canal. Supplement with returns of

### THE CENSUS OF 1900

Furnished every buyer of this Atlas FREE. Agents are positively clearing \$20 to \$50 a week. You can do it. Low Price. Write for particulars, stating experience if any.

ADDRESS THE CROWELL AND KIRKPATRICK CO. SPRINGFIELD, OHIO

## OUR NEW PREMIUM LIST

FOR 1900 IS NOW READY

It fully illustrates the extensive line of high-class premiums which we offer for raising clubs for the FARM AND FIRESIDE. The premium offers are the most liberal ever made, and every article is backed by a positive guarantee. Now is the time to get up clubs, and by so doing you can easily obtain some of the elegant premiums without any expense whatever. Cash commission if you prefer. Write for the New Premium List and full particulars to-day—sent Free. Address FARM AND FIRESIDE, Springfield, Ohio.

## WHY SUFFER

Orange Pile Cure cures Piles permanently. Instant relief. Never known to fail. By mail 50 cents. DR. M. E. MOREY, ROCHESTER, NEW YORK.



LIBRARY  
RECEIVED  
JUN 13 1900



Vol. XXIII. No. 18

EASTERN EDITION

JUNE 15, 1900

Entered at the Post-office at Springfield, Ohio, as second-class mail matter

TERMS { 50 CENTS A YEAR  
24 NUMBERS

### SILENT FORCES AT WORK IN CHINA

Opening Up the Country to American Trade

Inferior Chinese Methods of Manufacturing Paper, Sugar and Flour

BY WILLIAM N. BREWSTER

**T**HE opening of China is inevitable. The government is fighting hard against it. Most of the leading officials are at heart bitterly opposed to it. The people as a rule know but very little about the outside world, and both their natural disposition and education are set against change of any sort. To the casual observer the forces at work opposing reform and opening of the country are overwhelming. But a deeper study of the conditions reveals counter forces working outside of China, which in the end must triumph.

The conservative party in the government cannot touch them. The ignorance and prejudice of the people are powerless against them. Their work is as silent as gravitation, and as irresistible. These forces are the Western methods of producing the necessaries of life. When Western goods are better and cheaper than the native article the most prejudiced and ignorant Chinese will ultimately buy them. The Chinese are the Jews of the Orient. The Jew thrives in every land except China. Trade is an instinct with the almond-eyed Celestial. Convince him that Western goods are cheaper and better than his own and he will buy them. But he wants the demonstration to be clear.

To illustrate: This is being written with pencil upon paper made in England. But it is manufactured there for the Chinese trade. China consumes paper in enormous quantities. It is all unglazed, thin and flimsy. It is generally light buff in color. They print on one side only, and fold the paper in, making a book, each leaf being double. Their paper is mostly made of bamboo, something like wood-pulp used in America. The process is crude, and about ten per cent of the sheets are imperfect. Transportation from the mountains where the bamboo grows is expensive, so that the paper is cheap only in quality. A shrewd English manufacturer of paper has studied the Chinese market and produced this light buff paper, glazed on one side, strong and perfect, and is importing and selling it at practically native prices. This means that before long Chinese paper-manufacturers will have to adopt foreign methods of making paper or they will quit the business, and Western countries will supply this great market. It goes without saying that before long they will change their methods, buy machinery in America or England, employ a foreign superintendent, and make this paper in China.

Take the sugar industry as another example. Good "coffee A" sugar is now retailed at Foochow at about the same price that native so-called white sugar costs in Hinghua. Yet the sugar is grown here, and it costs half a cent a pound to carry it two days overland to Foochow, the nearest large market; so that in Foochow foreign white sugar is cheaper than the native article. Add to this the fact that the native sugar is dirty and gritty, and not white, it goes without saying that the sugar industry here is doomed if the people do not change their methods.

Sugar is now being produced in the Malay peninsula and islands upon a large scale with English capital, machinery and skill. Land is abundant and cheap, no fertilizer is needed, and water transportation to China costs little. But here land is expensive, and it must be heavily fertilized; their stone rollers cannot press the cane dry even running through three times. Their cooking in kettles instead of evaporating pans increases the amount of fuel used, and lowers the quality of the product. Their refining process is the crudest possible, and the results cannot compare with the foreign sugar. Then add to all these disadvantages the cost of carrying every pound upon the

shoulders of men for two days overland to market, and it is easy to see why the Hinghua sugar industry is in a very perilous condition. This year there is but half a crop; but in spite of that prices have ranged twenty per cent lower than last year because of this foreign competition. When American enterprise begins to develop the enormous possibilities in this line in the Philippines the competition will be still more severe. So it is plain that one of two things must happen in the near future: Either the sugar industry on the coast of South China will die out entirely, or their crude and wasteful methods of production will be changed, and railroads will be built to carry the products to market at a tenth of the present cost. It is far more probable that the latter will be the result than the former. China cannot afford to buy all her sugar abroad, and she cannot afford to pay more for native-grown sugar than the imported article would cost.

Take the still more essential article of flour. Wheat is grown in great quantities all over China. In South China it is sown in November and harvested in March. In northern-latitudes it follows temperate-zone seasons. But in spite of cheap labor the price of Chinese wheat is little below the American grain, though it is so dirty and irregular in size of grain and shriveled that it would hardly sell at all in the American market. But that is not its worst feature. Chinese flour is only fit for paste and pig feed. The grain is dampened to make it easy to grind. It is run through from seven to nine times between heavy stones, whose two faces grind off into the flour, filling it with grit. Bolting is no less crude. Water-power is used when possible; when not a cow serves instead. The stone turns as fast as the cow walks. The flour thus produced is so damp it will not keep more than ten days. Add to these defects the almost universal adulteration and you have in Chinese flour a mess that would not sell at all in any other market in the world. Yet the price is little below that of the lower grades of American flour now being shipped in such great quantities from our Pacific coast and sold to the Chinese. The demand for the foreign article is steadily and rapidly increasing. It is evident that the Chinese must improve their methods of making flour or soon quit growing wheat in South China. The price of wheat here is nearly, if not quite, that in America. They cannot raise it for less because of the high price of land and cost of fertilization. What the result will be is difficult



IMPERIAL TEMPLE—PEKIN

to predict, but it is hardly possible that China can afford to buy all or nearly all of her wheat abroad.

The same is true of spinning and weaving cotton goods. All the Chinese wear cotton clothing from the cradle to the grave. Yet they spin the yarn one thread at a time by hand. This is of necessity expensive, coarse and uneven. Already the importation of American cotton goods has assumed large proportions, that are increasing by leaps and bounds. In Shanghai large cotton-mills have been built, but are not paying well. The reason is plain. They must use coal, when most of the American mills run with water-power. Then Shanghai is an expensive place to live, and labor is in such demand that these mills pay from two to five times the ordinary cost of labor in China. The mills are confined to Shanghai because the interior is so badly governed that capitalists will not risk their money there. Water-power and cheap labor are limitless in China, but they are found together in the vast interior, where the mandarin flourishes and all else languishes.

But these conditions are certainly temporary. The Chinese can less afford to buy their cotton abroad than they can their paper or sugar or wheat. Cotton is grown in great quantities, but of poor quality. If they would improve their seed and methods of cultivation, and under a stable and just government open the untold resources of the interior to modern machinery for manufacturing their raw products into the necessaries of life, China would become one of the world's greatest producers. But all this will mean prosperity, which means civilization; and civilization has been well defined as "the multiplication of man's wants." Each supply will create a new demand, and the more China learns to produce the more will these teeming millions buy from their neighbors across the sea.

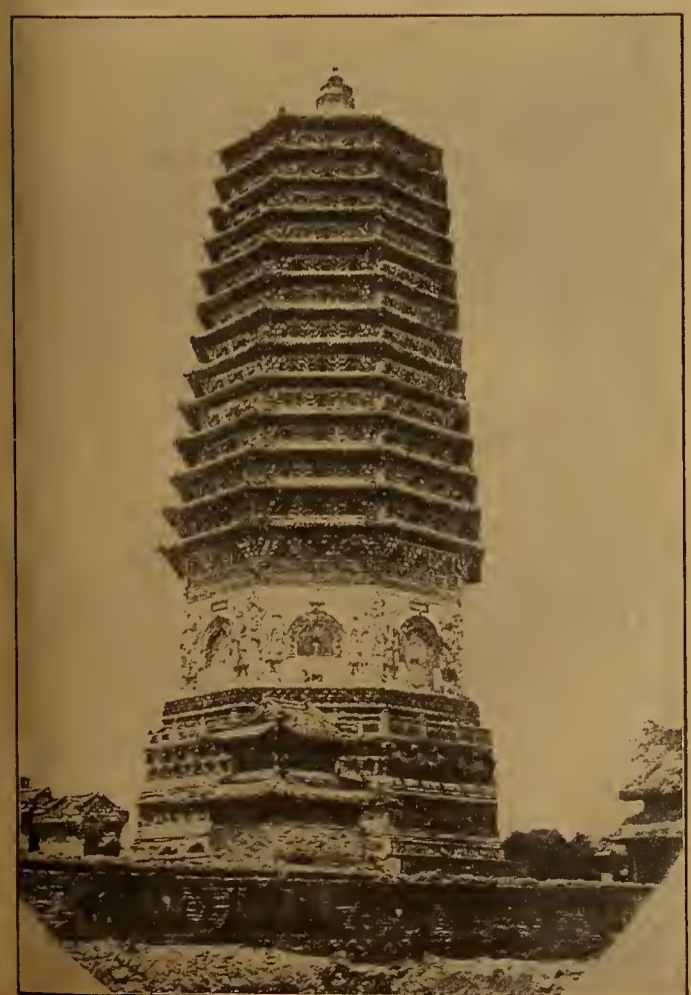

PAGODA IN SOUTH CHINA



## FARM AND FIRESIDE

PUBLISHED BY

THE CROWELL &amp; KIRKPATRICK CO.

OFFICES:  
 147 Nassau Street, New York City  
 Springfield, Ohio  
 204 Dearborn Street, Chicago, Illinois

Subscriptions and all business letters may be addressed to "FARM AND FIRESIDE," at either one of the above-mentioned offices; letters for the Editor should be marked EDITOR.

## TERMS OF SUBSCRIPTION

One Year - (24 Numbers) - 50 Cents  
 Six Months - (12 Numbers) - 30 Cents

The above rates include the payment of postage by us. All subscriptions commence with the issue on press when order is received.

Subscribers receive this paper twice a month, which is twice as often as most other farm and family journals are issued.

**Payment**, when sent by mail, should be made in Express or Post-office Money-orders, Bank Checks or Drafts. WHEN NEITHER OF THESE CAN BE PROCURED, send the money in a registered letter. All postmasters are required to register letters whenever requested to do so. DO NOT SEND CHECKS ON BANKS IN SMALL TOWNS.

**Silver**, when sent through the mail, should be carefully wrapped in cloth or strong paper, so as not to wear a hole through the envelope as I get lost.

**Postage-stamps** will be received in payment for subscriptions in sums less than one dollar, if for every 25 cents in stamps you add one-cent stamp extra, because we must sell postage-stamps at a loss.

**The date** on the "yellow label" shows the time to which each subscriber has paid. Thus: July 1900 means that the subscription is paid up to July, 1900; Aug 1900, to August, 1900, and so on. When a coin-card order-blank is inclosed with your paper it means your time is out and is an invitation to you to renew.

**When money is received**, the date will be changed within four weeks, which will answer for a receipt.

**When renewing** your subscription, do not fail to say it is a renewal. If all our subscribers will do this, a great deal of trouble will be avoided. Also give your name and initials just as now on the yellow address label; don't change it to some other member of the family; if the paper is now coming in your wife's name, sign her name, just as it is on the label, to your letter of renewal. Always name your post-office.

## The Advertisers in This Paper

We believe that all the advertisements in this paper are from reliable firms or business men, and do not intentionally or knowingly insert advertisements from any but reliable parties; if subscribers find any of them to be otherwise we should be glad to know it. Always mention this paper when answering advertisements, as advertisers often have different things advertised in several papers.



## NOTICE TO SUBSCRIBERS

**T**HE date on the "yellow label" shows the time to which your subscription has been paid.

Heretofore we have stamped the last number of the paper paid for "Your time is out." Conforming to a rule of the post-office department, this practice will be discontinued. Hereafter the last number paid for will contain a coin-card order-blank, which is a notice that your time is out, and also an invitation to renew promptly.

Just fill out the blank, put the money in the card, seal it in place and inclose the card to us under a two-cent stamp, and your subscription will be promptly renewed.

**O**NE of the bills," says the Boston "Herald," "which there is an apparent determination to press through the national House of Representatives at its present session is that for the taxing of oleomargarine out of existence. It is an instance of attempted extermination by taxation, the bill putting the tax upon the article so high as to prevent its production. It is a ruthless exercise of the taxing power, and one obviously outside of the intention of those who conferred it upon the government. The applicants for it are the makers of butter, who wish to extinguish competition in that article from oleomargarine producers. They are powerfully represented in the rural regions of the West, and the bill is reported by Representative Grout of the New England state of Vermont. We do not understand that it is claimed that oleomargarine is not a healthful product, or, if it is, the balance of testimony appears to be in its favor in this respect. It provides a cheap substitute for butter, with which many of the poorer classes of the cities of the nation are content, but their representatives in Congress are presumably less numerous than those coming from bucolic regions."

The "Herald's" comment carries some false impressions oleo advocates seek to make, which are that oleo is a cheap, wholesome substitute for butter, and that the Grout bill, if enacted, would exterminate a legitimate industry. The Grout bill is a measure to exterminate fraud. It imposes a tax of ten cents a pound only on oleo colored in imitation of butter. It does not interfere with the industry of making and selling oleo for what it is. Common oleo in the market is not a wholesome food, nor is it cheap to the consumer. "The poorer classes in the cities" are defrauded into paying high prices for a cheap substitute for butter. Manufacturers and dealers in oleo colored in imitation of butter and sold as butter for butter prices are making enormous profits out of the "cheap substitute," and they are using every means to defeat a measure that will exterminate the fraud in their business. If there is nothing left of their business after the fraud is exterminated—and they seem to admit this by the position they take—so much the worse for the business, and the stronger the reason for passing the Grout bill.

The majority report of the House committee on agriculture reads, in part, as follows:

"We are of the opinion that the people have ample cause for alarm at the tremendous illegal growth of the oleomargarine traffic in this country during the past few years, which now appears to have reached proportions beyond the power of the states to successfully regulate or control, and the present federal laws are apparently altogether inadequate for the emergency.

"We find that the very foundation and cause of the enormous amount of fraud and illegal selling of oleomargarine is in the great profits which are derived from the sale of the imitation because of its absolute counterfeit of butter, which enables unscrupulous dealers to impose upon unsuspecting customers. The profits are sufficiently large to cause the retailer to run the chances of detection and prosecution, and they are further emboldened and encouraged through the guarantees of the manufacturers of protection against prosecutions under the state laws.

"The tax of ten cents a pound upon oleomargarine colored to resemble butter will not deprive the manufacturers and dealers or consumers of any great amount of legal right they now possess.

"We believe the manufacture and sale of oleomargarine will continue under this measure, and that those who desire a cheap substitute for butter will purchase the uncolored article. The only difference is that the counterfeit article colored in imitation of butter will no longer be accessible to hotel-keepers, restaurant-keepers and boarding-house proprietors at such prices as will be an inducement for them to deceive their guests, as is now, we believe, absolutely universal where it is served; and thus another class of consumers who have been subjected to imposition for more than twenty years will be able to know whether they are eating butter-fat or hog-fat which they spread on their bread.

"Serious conditions require drastic measures, and it certainly appears from the testimony of those representing the producers of butter, as well as from the admissions of the witnesses for the other side, that those who are engaged in this oleomargarine traffic have absolutely no regard for state laws, and regard the public as their legitimate victim, in whose behalf they resent the interference of the general government. The continued existence of such a condition, we cannot but believe, furnishes a demoralizing example to our people in trade, who are being tutored by this oleomargarine interest in the art of evasion and defiance of the legally constituted authorities."

**I**N A letter to Adjutant-General Corbin General Theodore Schwan says: "Excluding the savage mountain tribes and those directly connected with small bands of bushwhacking brigands, the

Filipinos may be roughly divided into two classes; namely, the intelligent, educated (also, as a rule, the property-owning) class, who form a small minority, and the uneducated, laboring, or peasant, class, constituting the great mass of the people. Most men of both classes honestly desire the restoration of peace and order under American or any other kind of rule, being thoroughly weary of war. Those of the former class, for the most part, prefer American rule, believing that, though mild, it will be firm, and, above all, just, and because they have no faith in the fitness of the Filipinos as a people to govern themselves. They are, however, afraid to cast their lot unreservedly with the Americans, fearful that the anticipated withdrawal of American troops may expose them to severe treatment at the hands of the insurgent leaders, who, with even a small following, seem to be able to terrorize the people, and in the past have shown a vindictiveness and cruelty almost beyond parallel. Hence, while yielding a passive obedience to, or at least refraining from, positively hostile acts against the military (American) occupants, some of them keep up relations with and contribute to the needs of the guerilla bands in their neighborhood, promiscuously made up of robbers and ex-insurgents. Many men of the lower class, while preferring a quiet, humdrum life to the hardships and dangers of highwaymen and bushwhackers, are yet amenable to the persuasions or threats of the brigand chiefs, and join or quit the brigand service according to circumstances.

"Those who actively or openly seek to maintain brigandage as a nucleus or rallying-point for a future rebellion are the military and political leaders of the late organized insurrection, of whom all but a few are utterly unscrupulous and actuated by purely selfish motives. These men realize that, should the insurgent movement die out entirely, and American rule be firmly established, they will forfeit forever positions of influence and prominence, and will be relegated to their former obscurity and penury in private station."

Commenting on this clear statement of the present situation the New York "Sun" says:

"General Schwan says in his interesting letter on conditions in the Philippines that the educated natives have no faith in the fitness of their people to govern themselves, and, for the most part, prefer American rule; and that the great mass of the peasantry desire American rule or any other that will give them peace and order. A large part of both classes, however, are afraid openly to declare in favor of American rule, because they know that the insurgent leaders, even with a small following, have in the past inflicted and may again visit the most barbarous cruelties upon peace-loving men and women who fall into their hands.

"This statement is wholly in line with that of President Schurman, who, in his recent address before the American Geographical Society, declared that the Filipinos never asked for independence from Spain, but presented grievances and demanded redress; and that since the islands passed into our hands independence has been the shibboleth merely of a few ambitious leaders, while the masses, tired of war, crave only peace, and the aspirations of the most intelligent class will be satisfied with religious liberty, civil rights and such extension of the franchise as the people are capable of exercising.

"The touching spectacle of eight million people fighting for the independence of their country has, in fact, been wholly evolved from the imagination of the Aguinaldo party in the United States. The Filipinos have not asked for independence, do not want it, and would not know what to do with it. The remedy they do want for the evils they have suffered for centuries is to be found along the lines of the American policy as indicated by the Philip-

pine commission—protection for life and property, religious freedom, and local self-government wherever the people are capable of exercising it."

**I**N THE June "McClure's" Mr. F. Edmund Garrett concludes an interesting sketch of Paul Kruger as follows:

"The reality is to be read in all Mr. Kruger's past acts, and in his words at the Bloemfontein Conference, when Sir Alfred Milner put forward proposals involving, not the immediate, not the certain, but the probable ultimate loss of a monopoly of power by the Dutch-speaking graziers. 'It would be worse than annexation.' 'We might as well throw up the Republic.' Independence shared with the other classes and other white races would be 'independence lost.' So Mr. Kruger said; and so he has ever genuinely felt. To speak to him of the young Republic being made great and populous by wave on wave of new blood from Europe, like the United States, is like promising him a future life merged in Nirvana. When he thinks of the fatherland, the inspiring thought no more embraces the English speakers who have followed the Boers thither than the Kafirs who were there before them. It does not even embrace the South African Dutch generally, as he has bluntly shown his Cape kinsmen by his policy toward their railways, their products and their young men, ousted by more pliant clerks from Holland. Nay, even among the Transvaal Boers themselves the circle is narrowed when it comes to be a question of the sovereign will of the people and of deciding who the people really are, as the election affairs of 1893 showed. Boers who are not faithful to the country—to Dopperdom, to the Kruger elan and policy—do not count. In short, the 'land and folk' for which Paul Kruger has lived, and for which he would die [?], means really a few thousands of families of Franco-Dutch extraction, speaking a Dutch 'patois,' all either cattle-keepers or officials, or both, and largely interconnected by ties of marriage, of religious sectarianism, and of political patronage. The groove of such a patriotism may seem strangely narrow—it is intense in proportion.

"Paul Kruger is a visionary; what is his vision? It is a sort of oligarchic theocracy, with Paul Kruger as its Melchizedek, priest and king in one. He sees the faithful each under his own gum-tree, on his own 'stoep,' and as far as his eye ranges that is his farm, and his cattle are on a score of hills. The young men are stalwart, great hunters before the Lord, and the young women are grossly built and fruitful. And to each farm is a made road and a dam, and the stranger in the land pays for the same. The stranger keeps to himself in the city, and is more or less godless, for he is not of the chosen in the Promised Land. But he gives no trouble, for he is 'well disposed,' and looks to the Raad for his laws in due season. The burgher has his Kafirs, who do his work, but they are not cruelly used, because they obey. The sons of the soil are not too much educated, because that spoils an Afrikaner; but enough to hold all offices of state, that these may be purged of the Hollander and the German, no less than the accursed English or English-hearted Afrikaner. And the nations of the earth come vying the one with the other for favors, Germany and France and England, all on the one footing.

"And above all sits Paul Kruger, father of his people, dwelling in the house that the 'concessionnaire' Nellenapins gave him, wealthy, but thrifty, living as simply as he used to live on the farm, save that sheep's head and trotters come around somewhat oftener. And the judges come to him to know how they shall judge, and the Raad members to know what laws they shall make; and on Sundays all come to the little chapel near to hear him expound the Word of God and the truth as set forth by the Separatist Reformed Brethren. And there is peace in the earth. And the earth is flat, and the sun goes round it."

Happily, the vision has vanished.





## ABOUT RURAL AFFAIRS

### Tastes Differ

I have had another lot of communications from FARM AND FIRESIDE readers about the "blue-husk tomato." The most noticeable thing about these communications is the great diversity of opinions in regard to its value as a culinary article. A California reader says he found them worthless for him. "As a novelty they are a success, but once raised is enough, while the ground-cherry is delicious as preserves." Another reader prefers the blue-husk tomato to the cherry tomato, and finds them excellent for sauce and pies. "Like the yellow kind, plants of the blue husk will come up wherever a ripe or half-ripe specimen is left on the ground over winter. The plants grow from two to three feet high, and are very productive." We see from this that it will not do to condemn a vegetable or fruit because we do not happen to like it, or have not found the right way of preparing it for the table. This, indeed, is the case with a great many other vegetables and fruits. Some people like spinach, while others may find it of no greater value to them than so much cow feed. The same may be said of dandelions. I find that there are many people who do not care for that high-priced vegetable, asparagus. It is true that the great majority of people think highly of it, and I believe the great majority of those who profess not to like it would find it very palatable (as palatable as it is wholesome) if it were prepared by a skilful cook or in a manner just suited to their individual tastes. Many people like the flavor of most herbs, such as sweet marjoram, savory, sage, thyme, tarragon, etc. For myself I place very little value on any of them; yet I do advise people to plant them.

\*\*\*

### The Evolution of Fruits

Another point of view which must be taken of these plants and fruits that seem of little value is the possibility of their further development and evolution. They may be capable of serving as a starting-point for something of great value. All our best fruits and vegetables have been developed from a very inferior, perhaps entirely worthless, stock or original. The husk tomatoes seem to be more fixed in their habits than the modern varieties of ordinary tomatoes. The latter vary greatly; so much, indeed, that it is not an easy matter to keep any given variety for many years true to the original in every way. The yellow husk has not varied much, so far as I have been able to observe. This will probably be the case with the blue husk; but sometimes changes can be brought about by crossing and careful selection. We have yet many wild vegetables and fruits that may well repay the careful efforts of careful propagators for their improvement or for the origination of new types.

\*\*\*

### Tillage Before Planting

Just now we are always in a hurry, being anxious to get through with the planting. There is often a strong temptation to slight the job of preparing the soil. Many of our lands here require a great deal of work to get them in best shape for receiving seeds, potatoes, etc., and I find that it does not pay to be so much in a hurry as to plant in soil that is not in the very best condition for planting. A few weeks ago I planted an acre or less of Early Ohio potatoes, for which I expect a good price in July and August. The land had been plowed and doubly pulverized, rolled and pulverized again, and rerolled, then marked out, furrowed out, fertilized with chemicals, refurrowed or trenched, and planted. Yet the soil was still lumpy in spots, and when I did plant I regretted that I had not gone through the whole series of manipulations, from plowing to rolling, once more before planting. For planting potatoes on our loams, which are always liable to be somewhat

lumpy, I am more and more taking a fancy to the plan of working the soil on both sides; that is, plowing and pulverizing until the top presents a perfect seed-bed, and then turning this under again to be in the bottom, and once more pulverizing for the top what was before in the bottom of the furrow. Thus the whole surface layer, clear to the subsoil, is made thoroughly fine and mellow, and to plant in such a soil is a pleasure, as it is a pleasure to tend the crops afterward. Lumps are an eyesore to me. They contain a lot of good plant-food that the roots of the plants cannot get at and utilize. I would rather plant half an acre of potatoes in soil thus worked "on both sides" than an acre on land in the condition which most of us are contented with when planting.

\*\*\*

### The Fruit Prospect

At this writing the prospects for a full crop of fruits of all kinds are most flattering. If things turn out according to present promise and appearance the country will be flooded with fruits to an extent never even approached before. But there is many a slip between the cup and the lip, and we will have to wait and see. In the meantime I am going to try to keep the enemies of my fruits in check, and spraying seems yet the chief means of doing it. I have just cut down most of the trees in a young pear orchard of many varieties. The new San Jose scale so much dreaded and so much more generally distributed than was recognized or admitted by our growers and horticultural experts had gotten a good foothold in this pear orchard, and although only seen on a few trees last fall, was found in large numbers on the majority of the trees, and the only safe way to manage them seemed to be to cut down nearly the whole plantation, haul the trees upon heaps, spray with kerosene and set fire to them. I think this dreaded pest may be found in a great many of our orchards, and it will make a sudden end to the usefulness of thousands of young fruit and other trees.

\*\*\*

### Onion-thrip

The Ohio experiment station has issued a press bulletin, in which I find some remarks on the onion-thrip. Many growers are having trouble with this pest, and will be glad enough to hear of some treatment that promises relief. I quote from the bulletin as follows: "It has been found that the insect passes the winter months in matted grass, among old weeds and other rubbish, as well as among cull-onions and refuse that have been left over in the fields in the fall. Onion-growers are familiar with the fact that the depredations of this insect appear earliest, and are the most emphasized, along the margins of fields or plats, or in spots over the fields. The reason for this is that the insect winters over in these places. It makes its way from the grassy margins or from the grassy banks of ditches to the rows of onions adjoining. It winters over in the piles of culled onions and refuse in the fields, and begins its work there, spreading from thence outward. Wherever the grass and weeds along ditches can be rooted up and destroyed it prevents the harboring of this pest. Wherever the old, dry grasses and weeds along the margins of onion plantations can be burned the effect will be to destroy myriads of the pest and to prevent their breeding the coming season. With frequent, drenching rains there is not much likelihood of a severe outbreak, but in case of drought the insect is likely to work more or less injury in the extensive onion-fields of Ohio. A spray of one pound of whale-oil soap dissolved in eight gallons of water will destroy the pest, and the use of this mixture is recommended on the first appearance of the insects in the field. At the time of first appearance it will probably only be necessary to treat small areas in order to permanently check the increase." T. GREINER.

## SALIENT FARM NOTES

### The Man Working—

Some years ago, in company with a live, energetic young farmer, I called at the home of a well-known professor of agriculture. We expected to find him and everything about him as neat as a pin, a wonderful array of scientific apparatus in his rooms, an orchard, garden and arboretum in exquisite order, fields and plots laid off like a checker-board, and a complete outfit of the most improved tools and implements neatly stored in sheds and shops built in the most desirable form. What we found was a very ordinary house with almost common outbuildings—barn, carriage-house and tool-shed—and about such surroundings as any ordinarily prosperous and intelligent farmer might be expected to have. We found the professor—a bald-headed, unshaven, businesslike man—dressed in common clothes, building a post-and-board fence. He appeared to be very busy, so much so that he scarcely noticed us. We had no particular business with him except to have a good look at him and his surroundings, so after looking and making a few remarks about the weather we went our way. As we walked out at the gate my companion remarked, "I've seen enough of professors of agriculture! I'll bet ten cents I know as much about agriculture as he does!" Two years later we heard this same "professor" address a large gathering of farmers. At the close of the address my friend said, "What we saw building fence that day was the man. What we have just heard talk is the 'professor.' I am perfectly willing now to admit that he does know something—probably seventy or eighty per cent more than I do."

\*\*\*

### Road-working

A few days ago I saw a farmer working up a short piece of road that was in very bad condition most of last winter. I asked him how he could afford to work road at this season, when everybody else is busy with their crops. "This is why," he replied. "I have to travel over this every time I go to town. It has been in bad condition—in fact, next to impassable—the past two winters because it was worked up in the autumn. This year I made up my mind that I would repair it, grade it up good and drain it in the proper season if I had to stop plowing to do it. You know as well as I do that when a grade is built in May it will stay built. Before autumn the soil will settle hard and will remain firm all winter. That's why I am 'fooling away valuable time,' as a neighbor termed it, and working this road." I asked him if he did not think it would be better to pay his road taxes in money, and have all the work done at the proper time, than to have the road mutilated every fall and remain bad all winter and spring. He thought so, but had always voted against it because so many of the men elected road officers knew so little about building roads and keeping them in repair. Most of them knew more about petty politics and "distributing spoils" than about building good roads so that they would stay built.

\*\*\*

### Road Officers

The principal reason why such men are elected to these positions is because farmers allow the little pot gang of dry-goods-box politicians, to be found in every little hamlet, to manage their conventions and elections instead of taking hold of the matter like free and independent citizens should, and managing at least the road-running part in their own interest. Too often the road officers selected are men who are heelers for some local politician. I once overheard a local "boss" telling a newly elected road officer whom he should employ on bridge-work, grading, etc. The newly elected had two or three men of his own slated because they had materially assisted in having him nominated and elected, and he was somewhat puzzled as to how he could provide "work" for all. The "boss" informed him that he must cut them off with a little "work" and lots of promises, because the men he had mentioned must have a good pull at the public funds whether any-

body else got any or not. "We got you in," said he, "and now you must do the right thing by us, because the boys expect it. If you go back on us now the boys will remember it, and if you ever come up for anything else they'll fix you. I promised these men before election that they should have at least twenty-five dollars' worth of work apiece, and they've got to have it."

\*\*\*

The newly elected was sorely puzzled for a time, and he wished he had never become a candidate. He was honest, and wanted to accomplish something in the way of making the roads better, but found himself handicapped at the outset by being compelled to hire a lot of men who cared only to kill time and draw good pay for it. I saw one of these "workers" a few weeks later framing a four-foot culvert. He spent three days on it with saw, chisel and mallet, and drew therefor seven dollars and fifty cents. He spent another day "setting" the culvert in the place prepared for it by two more "workers," who had labored hard with spade and shovel for two days to have everything in readiness when he arrived. Another of the men the "boss" had promised to reward was given the task of cutting out some brush, crab-trees, etc., along the roadside. This stuff was not in the way, and there was no necessity for cutting it out, but the "worker" had been promised a pull at the public crib, and as there was nothing else he could do he was ordered to do that. He labored something over a week on what he could easily have accomplished in two days.

\*\*\*

### The Petty Political Boss

One would think that if anything would escape the fine handiwork of the petty political "boss" it would be the roads, but for years he has found them a ripe harvest-field. Votes give him his power, his influence, both at home and in political centers, and he is not slow to avail himself of the opportunities presented in the distribution of the funds raised "for road and bridge purposes," to so manipulate things as to make himself solid with that element that loves large pay for small work. "What's the reason So-and-so is not given something to do on the roads?" demanded a "boss" of a road officer. "Because he's no good," replied the officer. "I had him out one day and he couldn't do as much as a good ten-year-old boy, while he wanted his own way in everything." "That makes no difference," said the "boss," savagely; "you give him work! If he can't do one thing give him another. He owes me, and I want my money. Now you see that he gets work; right away, too!" To the great astonishment of the "boss" the officer bristled up and said he would employ whom he pleased, and he would not be dictated to by anybody. That finished him. When his term expired he was retired to private life.

\*\*\*

When a man is favorably mentioned for a road officer, and his neighbors desire his nomination, nine times in ten he is advised by a confidential heeler to see the "bosses" and secure their influence, because it is necessary. He does so, and they endeavor to impress him with the importance of their opinions and advice. He soon comes to imagine that they control most of the votes in that locality, and he stands ready to obey them in every particular, and to swallow without salt every statement they may make. He hangs upon their footsteps and delights in every word of encouragement they give him. If he fails of election they quickly convince him that he was not as good a "puller" as they thought he was, and thus cheapen his opinion of himself. If he is elected they quickly satisfy him that they were the parties that pulled the proper strings, and he believes them and is ready to do their bidding. That's how the petty political "boss" controls the funds raised by taxation "for road and bridge purposes." And that is how he will continue to control it until farmers have sense enough to come together and manage their road business in a sensible and businesslike manner.

FRED GRUNDY.



# OUR FARM

## FARM THEORY AND PRACTICE

**THE WEED PROBLEM.**—Weeds taken as a whole serve a useful purpose, and agriculture would be worse off than it is if there were none. They save neglected soils from waste, free plant-food that has been dormant, supply organic matter, and in our cultivated fields cause us to give the frequent tillage that crops need. They are a blessing in disguise, but sometimes the disguise seems to be pretty close and heavy.

But while it is true that farmers as a class have needed weeds to give a spur to good tillage and to cover neglected spots, the individual farmer should be progressive enough to pass beyond the need of such an ally, and when he does the presence of many kinds of weeds becomes a source of loss that he does not like to bear. He can and will provide plants that can do more for the soil than the so-called weeds, and he does not need them to cause him to harrow and cultivate.

\*\*\*

**WEEDS, HARMFUL AND HARMLESS.**—The list of noxious weeds changes with the locality. The kind of crop and soil have much to do in determining the character of the weed, as viewed by the farmer. The "worst" weed of one section may be very harmless indeed in another section. Many kinds of weeds do very little harm, yielding easily under the cultural conditions that prevail in the locality. Others bring heavy loss, because the crops and soil of the locality favor them. The latter are the ones that present a big problem to many of us, and yet one that usually can be solved.

\*\*\*

**STUDY YOUR WEEDS.**—I have a little plan to suggest to those farmers who make no pretense to a knowledge of botany, but want to fight their weeds in the cheapest and most effective manner. There may be on the farm a dozen kinds of weeds that are not easily controlled. While it would be well to know their names with exactness, in order that their nature might be studied in papers and books, yet this is not necessarily to close personal observation that will give one the facts needed for making an intelligent fight upon them. The habits and characteristics of each one of these noxious weeds should be studied until the farmer knows what it can and cannot withstand, just as he knows about his cultivated plants. He should know whether it is an annual or not, coming each year from seed like corn, or from an underground stem like potatoes, or from a root like timothy and other perennials. He should know when it comes, when it makes its seed, what the appearance of the seed is, whether it is propagated from the seed alone or from the roots, or both, how the seeds are distributed, and all kindred facts. This knowledge comes from a little continued observation. Then there is a chance to strike the weed at the weakest point and get it under control. The annuals are killed out by late cultivation. They must make seed or quit the farm, unless the seeds are brought upon the farm in grass-seeds or by the winds and other agencies. The biennial makes no seed the first year, and so we watch that it is prevented from seeding the second year of its life. That ends it. The perennials, especially those with underground stems, are often a terror. Exposure by plowing during a drought, or else shallow plowing and smothering in some way, is about the only way.

\*\*\*

**SMOTHERING WEEDS OUT.**—I confess to little faith in the plan of cleaning ground of all weed-seed, though I have nearly accomplished this in the case of common plantain. Such a mean perennial as the bindweeds I have killed out by exposure to the sunshine during a drought, but in the control of our worst weeds I have more faith in smothering than in any other process. If the leaf cannot grow the root must die. Surface cultivation for some of these

weeds, and heavy fertilization and seeding to a rank-growing crop for others, are the most effective means in practical farming. The difficulty is that this often calls for a change in one's crops or crop rotation, and often that is not liked by the farmer. In fact, most "worst" weeds of a locality are such simply because the crops and rotation have suited those weeds. A change might in time give some other kinds of weeds a chance to become noxious, and probably would do so, but it would make conditions unfavorable for the weeds that now annoy, provided the change were made intelligently.

\*\*\*

**THE SUMMER FALLOW.**—The nearly obsolete practice of summer fallowing could be revived in many instances with profit. We have many noxious weeds that ripen seed with grass, and therefore thrive in meadows. If the weedy grass were given back to the land by a summer plowing fertility would be added, and by summer cultivation the field could often be made sufficiently clean to permit a new seeding to take the ground. I have found an early summer plowing and a rank midsummer manurial crop a most effective means in gaining control over some noxious weeds. It was a change in cultural conditions they could not stand.

\*\*\*

**SAMPLES OF WEED-SEEDS.**—The farmer that wants to know his business can easily collect samples of the seeds of all his annoying weeds. Those that give little annoyance are of little moment. A good plan is to buy a score of small vials, and as each kind of weed ripens its seed a sample should be put into a vial and labeled with the common name of the weed or the one by which it is known to the farmer. He can then detect the impurities in grain or grass-seed that must be especially guarded against, and will know what seeds may be broadcasted over his fields by winds. It is true that he may learn all this by reading, and may apply it if he have the correct name of his weeds, but the knowledge that is gained by personal observation serves one best as a rule. It appeals to him and causes him to act upon it. An immense amount of effort is wasted in our fight against harmful weeds by reason of ignorance. We fight in the wrong way and at the wrong time. Some kinds of weeds are almost beyond control, because changes in crop rotation are not practicable; but others could easily be controlled if we made the same study of their habits of growth and reproduction as we give to the habits of our cultivated plants. DAVID.

2

### TO MAKE RECTANGULAR FIELDS

Every farmer is willing to agree that rectangular fields are less wasteful of land than fields of other shapes, and that straight lanes and roads running at right angles to or parallel with the sides of these fields are not only more economical of space and time, but are

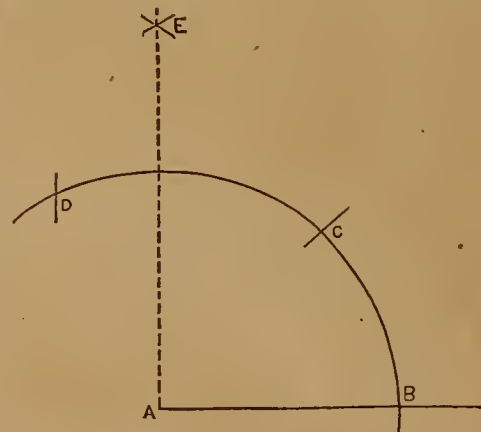

neater than irregular roads. It is not every man, however, that has a satisfactory way of making his roads and fields take these forms. Of course, where ravines and other formations of the surface occur roads and fences must conform to the surface more or less; but for ordinary places the following method, that the writer has used recently with satisfaction, may be employed.

Decide upon a straight base-line, and work from that. Start at one of the corners, A (see illustration), and measure back on the line any convenient distance, B, say twenty feet, using a piece of rope that will not stretch. Hold the

rope tight, and draw the arc BCD. Now start at B, and keeping the rope tight, mark the point C. From C mark off D, and also draw a little arc passing through E, which will be definitely located when the stationary end of the line is placed at D and the distance, twenty feet, marked off. The line drawn from A to E will be perpendicular to the base-line, and all that will now be necessary will be to extend this line by the usual method of sighting with poles.

M. G. KAINS.

### SELECTING A FARM

Buying a farm as an investment and buying a farm as a home are two things entirely different. In buying a farm solely as an investment the points to be taken into consideration are the income to be derived and the possible increase or decrease in value. In buying a country place solely as a home the whole matter of selection will be determined by the individual tastes as regards questions of beauty of location, convenience, etc. In either case it is supposed that the buyer is financially independent. The requirements are comparatively simple, so that the task of making a selection is not necessarily difficult. But buying a farm which shall be both a home and a source of income is still another thing. To select a farm which shall furnish a congenial home for the farmer and his family, and at the same time be a place where he may profitably invest capital and labor, is not always an easy task.

Supposing the case of a young married man of moderate means who wishes to buy a farm where he may raise a family properly and at least make a living as he goes along, what are the chief points to be considered in making a selection? As to the size of the farm that he might buy I should say the first thing to be taken into consideration is the pocketbook. It has been proven by many thousand examples that usually it is unwise to go largely in debt for a farm. To be sure, many farmers in the past, by good management, hard work and economy, have paid off large debts, and many are doing so now; but even in the case of those who are successful debt is a source of constant annoyance. Often it means excessive toil and self-sacrifices and deprivations that are most injurious, especially to the farmer's children, while to those who are unfortunate from any cause a large debt means almost certain ruin. As it is in other lines of business so it is in farming—capital counts for much more now than it did years ago. The man with abundant capital to thoroughly improve and equip his farm has a big advantage over the man who has not. In my judgment the day has gone when it is safe, in the eastern and middle states at least, for any man to buy a farm which he cannot own and equip without making large financial obligations. If he has not sufficient capital to buy reasonably clear of debt such a farm as he wants, he had better rent for a few years or go into some business where capital is not such an essential requirement.

As to locality one would naturally be governed in selecting a farm by any preference he might have for a certain line of farming. If he wants to engage in market-gardening, truck or fruit farming, a market near at hand, or at least a convenient means of reaching a good market, will be an essential factor. If he prefers the rearing of live stock he will care but little for a local market, but will want land adapted to pasturage. The man who has a passion for running improved machinery, and wants to engage in grain-farming, will never choose hillsides, though the man who raises poultry may turn them to a most profitable use; while he who engages in mixed farming wants a happy medium between the expensive lands of the market-gardener and the cheap lands of the granger. But for any purpose the income that can be derived from land, and consequently its value, depends very much upon location—more, I think, than is usually supposed. The man who can sell the produce of his farm direct from his own wagon to consumer has a great advantage over the man who must depend entirely upon shippers. Especially is this true when the market is

well supplied. And it is clear that the man who has to haul his produce only one mile to a retail market or shipping-station has a marked advantage over the man who has to haul it ten miles. And, likewise, the man who has five miles of good road between his farm and his market is in a more desirable position than the man who has five miles of bad road. As our cities, towns and villages grow larger, and the influences that draw men together grow stronger, the difference in value between farms that are well located and those that are poorly located becomes more marked. This is true probably more from social than from commercial considerations. A farm shut off from the busy, bustling and ever-interesting world by miles of bad road has little attraction as a place to live for the young farmer of energy and ambition, to whom life means but little if he cannot keep in touch with all the world's advancement. Such farms having but little attraction as homes have still less as a place to invest capital, for the very causes that make them relatively cheap now will make them relatively cheaper in the future. Men are realizing now as never before that for the highest development of manhood and the truest enjoyment of life the quickening and elevating influences that come from the intercourse of social life are a necessity. One in buying a farm should endeavor to get it so located that its value will be enhanced by every improvement made in the community—a farm that will find a buyer at any time that it might be placed upon the market.

As to the lay of the land and the character of the soil to be sought in buying a farm I would say there is but one kind of soil to be utterly avoided, and that is a soil naturally poor. Of course, a fertile soil is worth far more than a soil infertile from any cause. It costs no more to cultivate a rich field than a poor one. The one will yield a crop giving a profit above the cost of production, and the other very likely will not, and that is just the difference between farming that pays and farming that does not pay. But it must be remembered that land once fertile impoverished by continuous cropping still has in it in abundance most of the elements necessary to the sustenance of plaut life. The few elements that have been exhausted may be restored ordinarily by a few years of judicious cropping and fertilizing. But this business of restoring fertility is expensive, and the man who buys a thoroughly "run-down" farm should get it so cheap that he can afford to run it from two to five years without profit. For purposes of tillage a level farm, with large, smooth fields, is much to be preferred to one that is hilly; while for grazing a hilly farm, well watered, as they usually are, and requiring no expensive tiling, is perhaps preferable.

But the most important thing to be taken into consideration in buying a farm for the purpose indicated is neither size, value, location, fertility nor improvements, but the character of the neighborhood in which it is situated. Communities differ in their make-up just as do individuals. Some communities are thrifty, enterprising and progressive; others are sluggish, shiftless and non-progressive. Living in the one there is a constant incentive to better farming and higher achievements in every line of activity; living in the other there are no incentives to improvement, and the influences on every hand tend to drive one from the farm. The reason so many farmers' boys have taken such an uncompromising dislike to farming is because their fathers and their fathers' neighbors were but bunglers at the business—really did not know how to farm. No greater mistake could one make, who is ambitious to succeed in his chosen calling, than to locate in a neighborhood the very appearance of which tends to discouragement and disgust. No greater mistake could one make, who has a true conception of the meaning and purpose of life, than to buy a home for his family in a community where the people care little or nothing for education, social culture or the higher development of the moral and spiritual sense. ALBERT REX.



## NOTES FROM GARDEN AND FIELD

**S**OWING AND PLANTING.—Since the latter part of April hardly a day has passed which did not find me at some time in its course in one of my garden-patches sowing or planting. While I must leave it to hired help to do most of the actual work on the place, I make it a point to do all of the seed-sowing in the garden myself, and for that purpose I have a garden-drill always in readiness for operation. Sometimes I go out before breakfast, sometimes after breakfast, sometimes just before or after dinner, and quite often after supper, to sow a few rows of radishes, carrots, beets, cabbage or whatever else may be needed in that line. I cannot trust the average hired man or boy with such jobs. With all my experience I sometimes miss it, too, by sowing either too much or too little seed. In order to do this thing just right we must exercise good judgment and know something about the germinating powers of the seed itself besides. If I sow old seed, for instance, I usually let it run from the drill a little more freely than if the seed is strictly fresh. Then again I try to hold to just the right distance between the rows. I used to make my rows for small stuff in the garden of the uniform width of twelve inches. I find that I can do better work in cultivating (with the wheel-hoe) if my rows are at least fourteen inches apart, and for vegetables which require a little more space, such as table-beets, parsnips, etc., I put about eighteen inches between the rows. For onions, radishes, lettuce, small carrots, etc., the narrower rows (fourteen inches) are just about right for convenience; and when I plant cabbages, beans or peas I skip every other row, and have the rows twenty-eight inches apart; just right for close cultivation by horse-power.

\*\*\*

It is not only the matter of quantity of seed to be sown with the drill or by hand which requires good judgment. We want a free supply of everything right along, and must sow just enough to have this full supply without a surplus that would represent only so much waste. The question comes up every day, "How many rows must I sow of this or that vegetable to just suit the requirements?" The closest calculator will make mistakes in this, and it would not be wise to depend on the judgment of an inexperienced person or small boy. Another thing is that I believe I know better than anybody whom I could hire for the work to what special vegetable each particular spot in my garden-patches is suited. The finest, loohest, richest soil—in short, the soil in best tilth—I use for celery-plants, onions, lettuce, and the like. A soil not quite so good may do for beets or carrots, and the coarser spots I may select for peas, beans and sweet-corn. Then again the warmest and richest I use for egg-plant, the warmest of only moderate fertility for tomatoes, sweet-corn, melons, etc., and so on.

\*\*\*

**CAREFUL CULTIVATION.**—If I can find the time I also prefer to run the hand-wheel hoe myself rather than leave that work to one of the boys. I can set the knives a little closer together in straddling the row than I would deem it safe to have them in the hands of most persons, especially youngsters. Even with the greatest care one will cut off an occasional plant, and this often happens just where the plant is needed to fill the row; but it reduces the labor of hand-weeding to a minimum. Hand-weeding is a job for which I have no especial love. If I run the wheel-hoe the boys have the advantage of the saving in this work; but no matter how disagreeable it may be to some, it has to be done, and be done properly. A good deal of care is also necessary in cultivating by horse-power. My rows of peas, beans, cabbages, mangels, etc., are usually made twenty-eight inches apart, as already stated. This is plenty far enough when you have a careful horse that knows enough to keep to his row. I set my Iron Age spike-tooth or harrow cultivator

for close work, and run up and down in each row, first crowding the plants on one side, and in returning crowding those on the other side. My old "Pete" has been in service nearly a quarter of a century, and he cannot be expected to do hard and steady work. But for light cultivating he is even now worth two young horses. He walks slowly and straight, and seems to know that the plants are not there for him to step on. He goes without lines as well as with them. He is the horse I pick out for pulling the cultivator every time; and I can afford to keep him for this very purpose until the day of his final exit.

\*\*\*

**COMBINATION CROPS.**—I always like to make the best use of every available foot of land. For instance, I have set a new strawberry plantation this spring (as I invariably do every spring). Most people set the plants a foot apart in the rows. With rows four feet apart this takes about eleven thousand plants to the acre. When I have varieties that are good plant-makers, such as Splendid, Warfield, Crescent, Bubach, Haverland, and in fact most others, I set the plants not less than three feet apart in the rows, and often as much as four feet apart. Even then, as I look over the patch set in this way last spring, I find that I have too many plants in the row. Plants might be set five feet apart and yet make a good matted row. In the first place, I have this saving of plants, as I need only three thousand plants to the acre instead of eleven thousand, like most other growers. Then I have a better matted row, and I also have a lot of space left for immediate use that I can devote to cabbages or other crops which will be off by the time that the young runners will need the room. My combination last year was strawberries and cabbages, a cabbage-plant being set midway between each two strawberry-plants. To-day you cannot see by the looks of the patch that the berry-plants were set so wide apart, or that any other crop was grown between them. This year I have a double combination; namely, strawberries, cabbages and onions. The ground is laid off in rows twenty-eight inches apart. Strawberry-plants are set four feet apart in every other row. Between the strawberry-plants in the row I have set Prizetaker and Gibraltar onion-plants, the latter to be pulled up for bunch-onions as soon as large enough, which will give to the strawberry-plants the whole row as soon as they need it. The middle row, between the strawberry rows, is planted with early cabbages and cauliflower. This arrangement will necessitate close cultivation and prompt attention to all these crops right along.

\*\*\*

**FEEDING STRAWBERRY-PLANTS.**—A reader in Texas complains that his strawberries when bearing a full crop only bring about one half of the berries to marketable size. The later half do not fill out nor color up well. If barnyard manure is applied the berries may get size, but not the desired color, and are soft and of poor flavor. It is the nature of the Wilson and Noonan, and others; too, to give at first good-sized fruit as the first half of the crop, and then when the plants become weakened by fruit-bearing, and perhaps the food supply gives out, as it is liable to do under ordinary treatment, to let the later berries dwindle down to nubbins, worthless for any purpose. They act that way with me, too. But I try to counteract that tendency by heavy feeding, and I am not so afraid of stable manure, either. In fact, I try to force the production of a good deal of foliage, and if I succeed in this I feel pretty sure of a good crop of berries. In our friend's case the soil seems to be so well supplied with nitrogen that further applications may be an injury rather than a benefit. For that reason I would suggest the use of mineral manures only, either in the form of wood ashes, with some superphosphate added if unleached, or alone and more in quantity if leached, or in the form of superphosphate and muriate of potash. The only nitrogen I would try is a very small quantity (say fifty pounds to the acre), applied at the first sign of growth in spring. T. GREINER.

## ORCHARD AND SMALL FRUITS

CONDUCTED BY SAMUEL B. GREEN

### INQUIRIES ANSWERED

**Scurfy Bark-louse.**—G. B. B., Galesville, Ill. The twig of apple-tree sent in is infested with the scurfy bark-louse (*Chionaspis furfurus*, Fitch). The insect is becoming wide-spread, but so far has not been abundant nor injurious in most localities. The best-known remedy is spraying the trees with whale-oil soap, one pound in two gallons of water. The best time to make the application is in early spring before the trees are covered with foliage. This should be followed by high cultivation and good horticultural treatment.

**Sand-cherry.**—A. J. M., Andrew, Iowa. The sand-cherry is a small wild cherry that is frequently found upon the poor lands of a large section of northern United States. It is more like a plum than a cherry, and in quality is puckery and inferior. It is almost a mistake to call it a cherry. It is quite productive of fruit and a regular bearer, but the fruit is quite liable to rot on the plants. They grow from two to four feet high, and the fruit ripens in July. The sand-cherry and the Richmond cannot be grafted together successfully. The June-herry is not the same as the huckleberry, but is the old service-berry, or shad-bush.

**Basswood.**—J. S., Franklin, Idaho. The basswood is somewhat difficult to grow from seed, owing to the fact that the seed seldom germinates the first year after it is sown, and the seedlings being quite tender. I have, however, grown it very successfully by sowing the seed in autumn in sandy loam, protecting it with hay through the following season, when it is started into growth very nicely a year from that spring. The seed may be gathered after it ripens either in the autumn or during the winter. Frequently, however, the fruit that remains on the trees over winter is sterile, having no seeds in them. It is generally best to gather the seed in the fall.

**Budding the Orange.**—S. G. M., Clovis, Cal. Oranges are successfully budded at any season when the stocks are making growth, but is more uncertain in time of severe drought. It is most generally done in spring or early summer. The shield-bud method is the simplest, and if properly tied no wax is required. I do not know of any wax called hudding-wax. Orange-trees are sometimes grafted by the veneer method, which can be done at any season. It is nothing more nor less than side-grafting. The scion must be tied firmly in place with raffia and the wounded parts covered with common grafting-wax. If growing scions are used they should be shaded a few days. The stock above need not be cut away until after the scion has united.

**Fruit-blossoms.**—J. R. G., Brownsville, Tenn. There are none of our fruit-trees or plants that produce flowers that are destructive, except in the fact that they may be unproductive, and in this way take some strength from the tree; but there is no necessity for removing them. In the case of strawberries, which is what I think you refer to, there are two classes of plants, one of which has few or no stamens in the flowers, and others have perfect flowers. If you are a beginner I would recommend that you try only those varieties that have a perfect flower until you are well acquainted with the subject, after which it will be all right to plant the kinds that have pistillate flowers only. One of the best berries for general use by the beginner is Bederwood, which is a strong-growing, perfect-flowering kind.

**Killing Ants.**—C. M. H., Merrill, Wis. Black ants are at times very injurious to apple and other fruit trees by eating off the bark near the surface of the ground. If their nest is near by, I think the best way for you to destroy them will be by getting a little hisulphid of carbon and putting perhaps a teaspoonful of it into their hole and covering the hole with a piece of cloth. The vapor from this material is heavy, deadly, and sinks rapidly into the nest. If it is impracticable for you to get hisulphid of carbon, and the nest is not too near the tree, a good way to destroy them is to pour perhaps a quart of gasoline into the hole, and after it is well soaked in set it on fire. Another remedy which has sometimes been used to good advantage is to mix arsenic with sugar and scatter it about the hole.

**Plum-trees Not Blooming—Plum-rot.**—M. C. A., Adelaide, Ohio. The abundance and other varieties of the Japanese class are too tender in flower for severe locations in the Northern states, and are apt to be killed in winter, which, I take it, is the trouble with yours. The rotting of the fruit is caused by plum-rot (*Monilia fructigena*). This disease causes the plum to rot, and afterward to dry up and remain upon the trees over winter, and it is from these dried plums that at this season of the year, and later, spores come which infect the young fruit. On this account these dried, mummified plums should be gathered and destroyed; but it should be done in the autumn or in the winter, so that

there may be no chance of their spreading the disease. Gashing of the bark of the tree will have no effect whatever upon the hardness of the buds or upon the rotting of the fruit, although under some conditions I am disposed to think that it may add to the general health of the tree.

**Plum-trees Not Bearing.**—L. L. G., Lincoln, Kan., writes: "Some one please tell me what ails my plum-trees. They are seedlings from Wild Goose plum, are seven years old, and never bear fruit or bloom."

**REPLY:**—Seedlings rarely ever begin to bear fruit as young as grafted or huddled trees, but native plums ought to show some fruit or at least bloom at that age. They are probably expending their energy in making wood growth, and need a little checking up. I would try root pruning on some of them. With a sharp spade cut a circle around the tree about three feet from the trunk, inserting it the full length of the blade, cutting off the roots at that distance from the tree. If no roots are met with at that distance it is evident that the tree has too strong a tap-root. In that case dig under one side of the tree until the tap-root is reached, and cut it off about fifteen to eighteen inches below the surface of the ground, and fill the soil back in place. Earlier fruiting is also induced by pinching out the ends or cutting back the summer's growth in July, or by breaking down the shoots near the middle without severing them. Fastening the branches down to a nearly horizontal position during the growing season also tends to the development of fruit-buds. Any process that checks wood growth leads to the promotion of fruit-spurs.

**Planting Apple and Pear Seed.**—Z. D., Waller, Texas. I have planted apple and pear seed both in autumn and spring with about equal success, but on some account prefer the autumn to spring. In loose, well-drained, loamy soils the autumn is undoubtedly the best time, except it be in dry, arid regions. Seeds generally germinate better if planted soon after they mature or are taken from the fruit. The seeds of apple and pear, if kept for spring planting, should first be mature or fully ripe. Second, they should not be stored wet or be allowed to become hard and dry through long exposure to heat and air; otherwise they will germinate unevenly or not at all. Most of the seeds of commerce are saved from the pomace of cider-mills, and they should be taken out while the pomace is fresh and sweet, or they are liable to be seriously injured. After they are washed out they should be spread thinly upon tables or boards and frequently stirred until naturally dry, and then if to be kept until spring they may be put away in boxes in slightly damp sand or saw-dust or powdered charcoal and kept in a cool, dry place until spring. A little freezing does no harm, but is not necessary for their germination. If planted in spring they should be put in as early as the ground is in condition to work. Sow in drills and cover about two inches deep, and if the seed is good to start with I cannot understand why they should fail to grow. In the latitude of southern Texas I should think that early in December or early March would be the most suitable time for planting.

**Spraying Cucumber and Squash Vines.**—C. E., Diaz, Mexico, writes: "1. What shall I use as a spray to destroy the striped bugs that infest cucumber and squash plants? 2. Last month I sowed seeds of egg-plant that came up well, but are now dying. The leaves seem to be eaten up by some insect, but I have not been able to locate the cause. I have once in awhile found a small fly under the leaf. Is this the cause of the trouble, or what? Please give me a remedy."

**REPLY:**—1. I have found that spraying with Paris green is a very successful method of destroying the striped cucumber-beetle, using one ounce of the Paris green in ten to twelve gallons of water. A small quantity of lime should be added, to prevent the burning of the foliage, say a little more than the weight of the poison. The first application should be made promptly as soon as they are discovered working on the plants, and one or two more may be needed after rains. Another successful method of keeping the bugs off the plants is to dust over the plants and around the hills a mixture of dry, air-slaked lime and fine wood ashes slightly moistened with kerosene. Only a very little kerosene is needed, and it should be added when the lime and ashes are put into a bucket for using. Go over them twice a day until the plants are out of danger. 2. I am of the opinion that the insect that has eaten the leaves of the egg-plant is some species of the flea-beetles—similar, if not the same—that are sometimes numerous on potato and tomato plants, and have been known to be very destructive to newly made strawberry-beds. While they appear to be a biting insect, they work on the under side of the leaves and around the stems, and with us spraying has not been a successful method of heading them off. A frequent dusting with the lime, ashes and kerosene mixture or the application of Paris green mixed in fine, dry land-plaster (gypsum), one pound of the Paris green to fifty of plaster, has to all appearances proved the means of saving the plants from destruction. These remedies are best applied with the insect-powder gun.



## THE TOP NOTCH IN FARMING

**T**HE top notch in farming. Where is it? Has any one ever reached it? Will any one ever do so? As in every other kind of business there is a point of excellence in farming which may well be called "the top notch." By this is meant a degree of success in all branches of the profession beyond which no one has yet gone, but toward which all may and should aspire. Just where does that point of excellence lie?

In my opinion the top-notch farmer is he who keeps his farm well, so that his farm may in return keep him well. The boundaries of his land are clearly defined and marked by good substantial fences. Fences are a pretty good criterion of the forcefulness of the man who owns them. Within the live fences on the premises of the top-notch farmer the various fields are laid out systematically, and separated from each other by well-kept cross-fences. At no season of the year are his cattle allowed to run upon the meadow-land. Everywhere there is an air of trim neatness, which gives one the impression that matters are always well in the hands of the owner. The buildings are also trim, neat and comfortable. They may not be luxurious, but they show signs of care. They are painted when they ought to be. The house has its lawn, with shrubs and flowers in their season. The barns are always in good repair—no flapping boards or slamming blinds or doors. The cattle are comfortably housed in winter, and at all times of the year the stock enjoy lying in the yard. It is a homelike picture.

\*\*\*

Then, the top-notch farmer never lacks for plenty of good food for man and beast. He never sells hay from the farm, preferring rather to feed it all out on the place. His granary contains stuff enough to carry his horses, cows and sheep safely through the longest winter. If he must buy anything in the line of feed he does so at the season when it may be had at the best advantage. He is not buying bran in the winter-time or meal in the spring. He has seen to it that his bins are well supplied in August or September. His cows are not vainly trying to find shelter on the leeward side of a fence when the wind is blowing a hurricane and the mercury is hunting for the bottom of the thermometer. They are all snug in the barn, chewing their cud and thanking their owner for his consideration, and showing their thankfulness by good returns at milking-time.

The top-notch farmer has his work done on time. If any chasing is to be done, he does the chasing. Pity the farmer whose work keeps him on the run from year's end to year's end! The top-notch farmer finishes his day's work before dark, and so has time to sit down and find out what has been going on in the world around him before bed-time. Sowing, reaping, everything is done when it ought to be.

\*\*\*

The top-notch farmer has his hand on the valve which controls the public affairs of his town, county, state and nation. There used to be a theory that the farmer ought not to have anything to do with politics. That theory has gone with the thousand and one other exploded notions which once prevailed as to the farmer's education. The farmer must be well posted in all that pertains to government, local and general. He must know who his public servants are, and insist that they shall be held to a strict accountability for all their deeds. He must do more. He must be ready to step right into the harness of public service himself if need be. We as farmers have suffered immensely because of this lack of preparation on the part of our own number. The opinion has long been held that the farmer is not fit to do anything except hold the plow and milk cows. Hail to the day when this infamous doctrine will be relegated to the oblivion it deserves. No class of men has better judgment, keener insight into things or firmer integrity than the farmers. Wherever they have forced their way to the front they have proved themselves to be faithful and efficient officials.

The top-notch farmer is a close ob-

server of the markets. He knows when to buy and when to sell. He is ready to take a fair living price for what he has to sell. When sheep are up and wool high he does not rush wildly to sheep. He may slightly increase his flock, but for the most part he keeps on the even tenor of his way, knowing that the tide will soon turn and disaster overtake the man who has loaded himself to the ground with sheep.

\*\*\*

Has any one ever reached this degree of excellence? Decidedly yes. In almost every community a few such men may be found. They are not saying much about it themselves, but they are steadily "sawing wood." And the number is constantly increasing. These men are an unfailing source of inspiration to all within the circle of their acquaintance. Let one top-notch farmer move into a neighborhood and proceed to put his place into good condition, and speedily others will begin to push to the front. Blessings on the good all-round farmer.

\*\*\*

How is the standing-room up where the top-notch farmer is? At a premium? No; absolutely exhausted! And that is as it ought to be. There is no "standing" room in this world for the man who would succeed, but there is plenty of space for the man who has a disposition to hustle—plenty of room for the top-notch farmer. And when they come, away goes the poor farmer. And away he ought to go. To the front we send our best soldiers. No use, for any one else. The times call for better work on the farm. Not more toil with weary hand and lagging feet, but with head and heart and soul. Think! think! O farmer! if you would reach the top. If you do not you will be forced out of the race, for the man who thinks is surely the man who will win. Are you a top-notch farmer? If not, why not? E. L. VINCENT.

↓

## CORRESPONDENCE

FROM IOWA.—Page county is one of the best in southwestern Iowa. The soil and water are good, and there are timber and coal for fuel, but the winters are long, and stock must be fed on an average of six months in the year. Land is worth from \$40 to \$65 an acre; some small tracts close to town more than that. Corn yields from forty to eighty bushels an acre, wheat fifteen to twenty-five, oats forty to sixty, and tame hay one and one half to two tons. Land rents for cash at from \$2.50 to \$3.50 an acre. R. R. M. Hepburn, Iowa.

FROM MONTANA.—This section of the Rockies is what is known as the ceded strip of the Blackfoot Indian Reservation, which was thrown open to mineral entries in April, 1898. The best-known district on this ceded strip is the "Swift Current Mining District," which is rapidly coming to the front as a mineral producer. This section of the Rockies is unusually rich in copper, with some gold and silver. The character of copper-ore in this district is known by the mineralogist as "bornite." Pure bornite runs fifty-five per cent copper. The leads in this section are very large and well defined. Assays as high as five per cent in copper have been known to have been made from surface croppings, and float has been found in the Iceberg-lake district that made \$20 in gold to the ton. We had our camp during the month of August, 1899, on the shores of Iceberg lake, which has an altitude of about eight thousand feet. During our stay there this lake was filled with icebergs as large as a good-sized house. The breeze would cause these large pieces of ice to float around, first on one side of the lake and then on the other; each day the spectator had a different magnificent view before him. One of the most wonderful sights an eye could witness is the way the Rocky-mountain goats climb these mountains. I have seen as many as twenty of these goats going up and down the mountain walls where it would be impossible for any human being to scale. There are mountain-sheep here in small herds, but as the country is settling up they are rapidly disappearing. Elk are here in the great pine forests that cover the foothills, or lower mountains, but as the country is being prospected and settled they also are disappearing. Deer, both black-tail and white-tail, are quite numerous, and fur-bearing animals, such as beaver, marten, etc., live here. Bears are very common, more common than most folks desire. One night last summer I left a case of butter and a can of syrup out in front of my cabin. The next morning when I went to get a fresh supply of butter I found that Master Bruin had made me a visit during the night and had relieved me of both butter and syrup. Durham is at present the nearest railroad-station, and is a distance of forty-five miles

from the "Swift Current Mining District." If you intend to prospect this summer this is the best place for you. Why go to Cape Nome when such opportunities can be had right here at home? C. E. M. Browning, Mont.

FROM VIRGINIA.—Rockingham county, one of the largest, wealthiest, most healthful and beautiful counties of the Old Dominion, is situated in the far-famed Shenandoah valley, walled in on its northern side by the Appalachian and on the east by the Massanutten mountains, whose towering peaks, kissed by the sun for countless ages, stand as gigantic sentinels guarding the peaceful army of toilers that till the fertile valley. It indeed well deserves the name of the "garden of Virginia." Strictly a farming county, its hills and vales are dotted with cozy farm cottages, with here and there a larger and more pretentious residence of some wealthy landowner. Wheat, corn, oats, barley, rye and hay are the principal crops grown here, and owing to our close proximity to the larger Eastern cities the products always bring fair prices. Stock-raising is also an important industry, thousands of cattle finding their way annually from our quiet fields to the busy marts of Baltimore, New York and Liverpool, England. Fruit-growing is assuming constantly increasing proportions in Rockingham county, as well as throughout the state. Within the past half-dozen years tens of thousands of apple, peach and many other varieties of fruit-trees have been set out. All fruits do well here with the exception of peaches, which, notwithstanding all that can be done for them, will not reach that state of perfection noticeable in other sections of the state. Land is high, ranging in price from \$30 to \$100 an acre; that close by the railroads and the larger streams often exceeding the latter amount. Harrisburg, the county-seat, is a thriving little city of 4,000 souls. Beautifully situated, it is one of the most picturesque towns in the state. It has many industries, that give employment to a large number of hands. It possesses many metropolitan features, such as electric-lights, sewerage system, a water-works second to none in the state, many handsome public buildings, including two massive courthouses—county and United States. Three railroads enter the town, giving to the surrounding farmers rapid and cheap transportation for themselves and crops. Another feature of our progressiveness, and one that has robbed farm-life of much of its monotony, is the telephone, the wires of which stretch in every direction, forming such a network of steel that is perhaps not equaled in any other rural county in the United States. Every business man, however small his establishment, has his 'phone. It is the same with the farmer; to be in the "push" he must have a 'phone, and as it seems to be the desire of every one to be in the "push," the consequences are nearly every one has a 'phone. At night, when the labors of the day are over, they go to their 'phones, call up their neighbors, and talk over the day's happenings. They thus keep in touch with the news of the day, transact business, call the doctor when his services are required, inquire at the post-office about the mail, etc., thus saving themselves many a weary ride, as well as affording them many hours of pure enjoyment. Within the past two or three years quite a number of our farmers have taken Greeley's advice and have gone West, most of them going to North Dakota, having been taken in by the golden tales told by immigration agents of that Eldorado of the Northwest. Many believed them, disposed of their comfortable homes here, went West and took up government land, only to come trooping back to "Old Virginia," some crippled for life by the cold, and all "cussing" the West in general, and North Dakota and the immigration agents in particular. Rockingham is possessed of educational advantages unsurpassed. Public and graded schools are thickly scattered all over the county, while Bridgewater college at Bridgewater, the Shenandoah Institute at Dayton, and the West Central Academy at Mt. Clinton, enjoy a patronage not bounded by the state lines. The county supports one daily and five weekly newspapers, while at Dayton is published the "Musical Million," a monthly magazine, known and read throughout the South, wherever music is appreciated. Our people are very quiet and religious. All the different denominations of Christianity are here represented, each owning its place of worship. Within the borders of this county numerous mineral springs abound, the best known of which are the Massanutten, Rawley and Sparkling. The former bears a reputation for health-giving qualities not surpassed by many waters in America. Negotiations are now in progress between the owners of this spring and agents of the United States government whereby the latter seek to purchase the springs and several hundred acres of the surrounding land. Should the government be successful in procuring this valuable property, Uncle Sam will build a sanatorium for broken-down soldiers and sailors. The surrounding farmers are watching the negotiations with interest, for should the government carry out the plans above mentioned, they see an excellent market for their surplus products. F. A. B. Cowan's Depot, Va.

**SILLO** The New **SMALLEY** Cutter

**SUCCESS** is assured if you use New Smalley Cutters with semi-circle carriers for cutting and elevating ensilage. They have automatic self feed, also Corn Shredding and Corn Husking attachment when desired. Mounted on 4 wheel trucks for easy moving. A strictly "up-to-date" machine. 1900 booklets mailed free. "Yankee Silo Sense" and "Farming on Business Principles." Ask for special introductory prices on Smalley and "Battle Creek" WOOD SAWS, GRINDING MILLS, EAR CORN CRUSHERS; also SWEEP TREAD AND STEAM POWERS, stating goods you wish to purchase and naming paper in which you saw this advertisement.

**makes the Silo pay**



Made Sold Works G. C. P. Works  
Smalley Mfg. Co. Mankato, Wis.

Six Sizes: Nos. 12, 14, 16, 18, 20, and 26.

**BICYCLES FOR EVERYBODY. NO MONEY IN ADVANCE.**

Shipped direct to anyone and guaranteed as represented or money refunded. Save agents large profits and get a wheel at rock bottom wholesale price. Our Arlington Model K is the greatest bargain ever offered; in lots of one or more at \$14.85

**\$14.85**

\$35 "Arlington" \$16.50  
\$40 " " \$18.50  
\$50 "Oakwood" \$21.50

Good wheels \$12.50, \$11.00 & \$10.00. Stripped wheels \$7.00

the Arlington & Oakwood are strictly high grade, and the best that can be made. Thoroughly tested and fully guaranteed. Over 100,000 riders can testify to their superior quality, style, construction and workmanship. Illustrated catalogue free. **CASH BUYERS' UNION, 162 W. Van Buren St., B-7, Chicago, Ills.**

**EARN A BICYCLE!**



By selling Baker's Teas, etc. No Money required; just take orders among friends and earn a splendid bicycle for a Lady or Gentleman or Boy or Girl. Hundreds of premiums in Watches, Furniture, Crockery, Cameras, Mackintoshes, etc. Express prepaid. Write to-day.

**W. G. BAKER (Dept. 87), Springfield, Mass.**

**ORNAMENTAL FENCE!**

25 different designs, they are all steel and cheaper than wood fence. Special prices to Churches and Cemeteries. Write us for catalogue.

**KOKOMO FENCE MCH. CO., 427 NORTH ST. KOKOMO, IND., U. S. A.**

**A HAY CROP** 38 Styles & Sizes.

and its value depends upon how it is marketed. Baled Hay finds a ready market anywhere.

**"ELI" Baling Presses**

make the most even, compact bales. Save freight in loading tall cars. Easiest and safest to feed. Feed hole 53x30 inches. They are built to last. Require the minimum of power. Write for FREE illustrated catalogue.

**COLLINS PLOW CO., 1116 Hampshire St., QUINCY, ILL.**

**WE SHIP ON BICYCLE \$100 DEPOSIT**

\$11.75 Buy a Bicycle Complete. Unguaranteed.  
\$16.50 Buy an Up-to-Date Model. Fully guaranteed.  
\$22.50 Buy a Full Railing Model. Shop-worn Bicycles from \$10 up. 2d Hand Wheels from \$5.00 up. We want Agents Everywhere. 64 page catalogues of bicycle parts and repairs FREE. Write for catalogue and see how you can get a BICYCLE FREE by helping us advertise. Address, Dept. A-3, VICTOR MANUFACTURING CO. 161-167 PLYMOUTH PL., CHICAGO, ILL.

**The Best Farm in Kansas**

Whether you want a farm for profit or a farm for leisure and pleasure, the Colony Farms are the best in Kansas, best anywhere—rich soil for crops, luxuriant natural grass for cattle-raising, fine woodland, pure water, delightful climate, in the heart of Nature's great shooting and fishing preserves. Free book, tells all about them, sent on request.

**J. B. LEWIS, 303 Congress Street, Boston, Mass.**

**SAVE THE MONEY**

you are spending on repairs and buy new wheels. It is cheaper and in every way better. We sell 4 Buggy Wheels, 7-8 in. Steel Tire for \$7.50 4 Carriage Wheels, 1 in. Steel Tire for \$8.00 Other wheels for other purposes equally low priced. Measuring directions free. Write for price list \$6.31.

**WILMINGTON WHEEL CO., Wilmington, Del.**

**We are the largest manufacturers of Steel Wheels and Truck Wagons in the World. Write for Catalogue. Havana (Ill.) Metal Wheel Co.**

**Brass Band**

Instruments, Drums, Uniforms, Supplies. Write for catalog. 445 illustrations. FREE! it gives information for musicians and new bands. **LYON & HEALY, 95 Adams St., CHICAGO.**

**Don't Throw Away Your Old Tire**

I have a Tire Compound especially adapted for slow leaks and porous tires. Tires guaranteed to last another season by using Haerr's Tire Compound. Contains no gunny or offensive ingredients so common to all tire cements. Trial package, enough for one tire, 15c.; two packages 25c., post-paid. **PHILIP HAERR, Springfield, Ohio.**

**Farmers** Your address on a postal will bring you my circular. **JOHN J. GREINER, Ogden, Utah.**



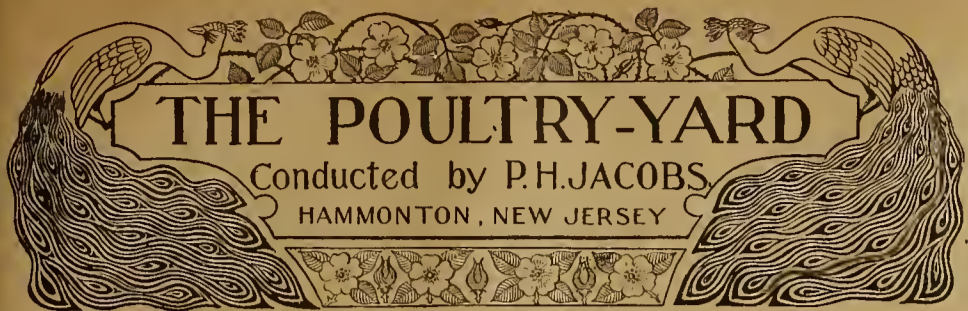

**GRASS THE CHEAPEST FOOD**

**A** VALUABLE experiment can be made by anybody who will take time to do so, by only confining a flock for a week or two on a small grass-plot. In a short time every blade of grass will be gone and the plot will appear as if burned over by fire. The birds will then be constantly forcing their heads through the wire to secure that on the outside which they can reach. This demonstrates that the birds not only relish grass, but that they will eat large quantities of it even when confined and heavily fed on other foods. At the same time, though eager to secure grass, there may be an abundance of grain in the space within which they are confined, and they will not be content as long as the grass is within sight of their yard. The fowls consume grass when on the range, as well as gravel, seeds, insects and waste material, having the power of selection of the kinds preferred, and they come up at night with their crops full. It may be claimed that as the hens on the range are usually busily at work all day they fill their crops several times, or rather they digest enough food during the day to equal that contained if the crops were filled several times. This fact should impress upon farmers the importance of avoiding the giving of grain or any carbonaceous food to fowls that are on the range, as such foods may make them too fat. It is not economical to feed fowls in summer if there is an abundance of food that they can otherwise secure; but there are good ranges, and also ranges that contain nothing, hence those who keep poultry must observe the conditions and regulate the feeding of the flocks accordingly. The object should be to produce eggs at the least cost for food and labor, and to utilize the natural conditions for securing a profit as far as it is possible to do so. Grass is the best and cheapest food that can be used for all kinds of fowls.

**SUNFLOWER-SEEDS**

Poultry-raisers and all keeping fowls should grow the Russian sunflower, as it is easy to cultivate and yields large quantities of seed, most excellent food for fowls, being egg-producing and a good change for poultry in the winter-time. It can be grown at about the same cost as corn. Plant the seed at corn-planting time, in rows three or four feet apart, and the hills one and one half feet apart in the rows, placing two or more seeds in a hill; or check the rows and cultivate the same as corn. If a patch is planted near the hen-house it will afford shade during the summer, and the seed-heads can be taken down and the fowls will eat the seed out, or the seed may be shelled when dry and kept for winter use. To shell the seed, make a club about fifteen inches long, take the seed-head by the stem, and with the club strike several sharp blows on the seed side of the head and the seeds will fall out. Five quarts will plant an acre, and will yield twenty or more bushels.

**HOW MUCH FEED A DAY**

It is impossible to state the exact amount of food required for fowls. Some estimate five pecks of grain (forty quarts) for a hen one year. This is about four fifths of a quart a week, or a little less than a gill a day. As one hundred hens will eat about six hundred gills a week, it is equivalent to seventy-five quarts, or about ten and one half quarts daily. The estimate is believed to be too high, as such feeding will make them fat. But the estimate includes that which may also be picked up. Ducks require more bulky food. A mess of cooked turnips or potatoes thickened with ground grain is better. They eat much more than

hens, but give quicker returns, as they grow faster. A turkey cannot be kept in confinement, and hence no estimate can be given of what it may pick up. Give all fowls as much as they will eat at night, but feed hens sparingly during the day. The estimate made here is for grain only. Other foods than grain may be allowed if necessary. Laying hens require more food than non-layers.

**CHEAP LATH FENCE**

A cheap fence should combine height and strength. If the large breeds are used, lath fence four or five feet high answers well, but as the small breeds are good flyers, that active quality should not be overlooked; hence, change the fence a little to suit the breed, by using a few more laths. To give such a fence strength, and also have it at least five feet high, without the use of boards, which are expensive, place posts in the ground eight feet apart; fasten a strip to each post eight inches above the ground, and another strip to the posts one foot above the first. Cut both in half, and nail the half pieces (which will be two feet in length) to the two strips, first driving the lower ends into the ground two or three inches. Next fasten on a strip to the posts three feet above the second one, and nail on whole lath, and the fence will be stronger at the bottom than at the top, thus preventing dogs from breaking in; and the lower laths, being driven into the ground a little, prevent the fowls from getting under. The fence will, of course, be a little less than a lath and a half high, or about six feet.

**KILLING POULTRY**

It is admitted that poultry when bled to death is whiter in flesh than when prepared in any other manner. Then the question is how to cause them to bleed to death and not disfigure them in any way. This can be easily done by opening the beak of the fowl, then with a sharp-pointed knife make an incision at the back of the roof, which will divide the vertebra and cause immediate death, after which hang up the fowl by the legs until the bleeding ceases. Next rinse the beak out with vinegar and water. Fowls killed in this way keep longer and do not present the unsightly external marks as those killed by the ordinary system of breaking the neck. When the entrails are drawn immediately after death, and the fowl dressed, stuff it to keep its shape; it will keep fresh much longer. It is a mistaken idea to cram poultry just before killing to make them appear heavy, as the undigested food soon begins to ferment, and putrefaction sets in, as is noticed by the quantity of greenish-looking fowls that are displayed in our markets.

**WHEN TO USE SULPHUR**

Sulphur exists in nearly all the materials fed to fowls, and like lime it can always be provided in the food and in better condition than when given as pure sulphur, as that in the grain is usually chemically combined with some other substance. For instance, sulphur exists in plaster, in copperas, magnesia, in some forms of soda and other substances that are classed as sulphates or sulphides, and these compounds are also ingredients in nearly all foods. But sulphur may be given in the pure state, however, only it must be done cautiously and not allowed to the fowls frequently. It purifies the blood, arrests disease, eradicates lice and sometimes invigorates the system. A teaspoonful of sulphur once a week in the soft food for twenty hens is enough, and it should never be given in damp weather, as it will cause rheumatism. It should not be fed to chicks in any form until they are at least three

months old. When an egg becomes rotten the disagreeable odor is due to sulphurated hydrogen gas. The food should contain all the sulphur necessary, but when the hens are producing eggs readily it is possible that there may be sufficiency of sulphur, which depends, however, upon the kind of food provided. So far as the lacking of sulphur in the eggs being the cause of eggs not hatching, there is no way to arrive at a correct knowledge of the fact, as it is difficult to estimate the amount of sulphur taken in food.

**FEEDING SQUABS**

When the soft food begins to leave the parent pigeons a slight change may be made in their diet by giving the ordinary hard food, such as broken beans or peas, in small quantities and adding a proportion of barley, wheat and cracked corn. At evening-time a little broken rice may be given. This treatment answers a twofold purpose, enabling both the parents to feed the young with apparent ease, disgorging their food into the mouths of the squabs, and also facilitating the swallowing capabilities of the latter. Should any squab be found more or less empty in crop after the evening meal has been given, it is advisable to resort to "hard feeding." For this purpose have ready soaked some grain, such as small peas, barley and a little cracked corn. Place this mixture in the mouth, and cause the squab, by inserting its open beak into the mouth, to feed itself therefrom.

**WARM-WEATHER SHIPMENTS**

When live fowls are sent to market during very warm weather the rule is to save the expense by crowding as many as possible in one coop. Water is placed where only a few can reach it, while the food becomes mixed with filth. When a coop of live fowls is placed in a car every fowl sits perfectly still while the car is in motion, making no attempt to eat or drink; but if plenty of drinking-cups are provided, and the birds have room enough in the coop to move, the attendants will give them water whenever the car stops. There is always a loss in weight of live fowls sent to market, but with proper precautions and a due regard for the rights of the fowls much of this loss at points of destination will be avoided.

**LATE CHICKS**

The best time to hatch pullets that are to lay early depends upon the breed, yet Plymouth Rocks or other large breeds may be hatched as late as June, and the small breeds in July if they are not intended for winter laying. All breeds (hens or chicks) may run together as long as eggs are desired for hatching, and no harm or mixing of breeds will result, provided the different breeds are separated a month before the eggs are used for hatching, and if there is a surplus they can be used on the table, especially the late chicks, so as to reduce the number and prevent crowding.

**INQUIRIES ANSWERED**

**Soft Shells.**—E. P. R., Huntsville, Ala., writes: "My hens lay soft-shell eggs. I have tried feeding lime, oyster-shells, etc., but the remedies seem useless."  
**REPLY:**—It is due to overfeeding. The best preventive for fowls that are very fat is to give no grass, but force them to seek their food on the range.  
**Mites.**—E. G. C., Orosl, Cal., writes: "Please give me a remedy for chicken-lice and small black lice."  
**REPLY:**—The best mode of ridding the house of lice is to spray with kerosene emulsion once a week. The advertised lice-killers are also excellent. Do not cease with one trial, but keep at it through the summer.  
**Capons.**—L. B., Roanoke, Va., writes: "Some time ago you mentioned a cross for producing choice capons; please give again."  
**REPLY:**—The following crosses are regarded as excellent, the male being mentioned first: Dorking-Brahma, Indian Game-Brahma, Dorking-Indian Game, Dorking-Cochin, Indian Game-Plymouth Rock.  
**Early Laying.**—J. M. B., Sandusky, Ohio, writes: "What is the earliest period in life that a pullet has been known to lay?"  
**REPLY:**—Some Leghorn and Hamburg pullets have been reported as laying when but fourteen weeks old, and others at sixteen weeks. They frequently begin, however, when twenty weeks old.

**TERRIFF'S PERFECT WASHER**

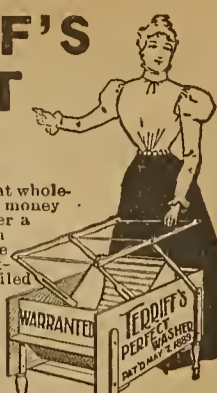

**SENT ON TRIAL** at wholesale price. If not satisfactory money will be refunded. **WARRANTED** under a **POSITIVE GUARANTEE** to wash as clean as can be done on the washboard, even to the wrist- and neckbands of the most soiled shirt, and with far greater ease. Does not wear out the clothes. Economizes soap, labor and time. **AGENTS WANTED.** Exclusive territory given. Big money made. For terms and prices Address, **Portland Mfg. Co., Box 27, Portland, Mich.**

**THE WHEEL OF TIME**  
 for all time is the  
**Metal Wheel.**  
 We make them in all sizes and varieties, **10 FIT ANY AXLE.** Any height, any width of tire desired. Our wheels are either direct or stagger spoke. Can **FIT YOUR WAGON** perfectly without change. **NO BREAKING DOWN.** No drying out. No resetting tires. Cheap because they endure. Send for catalogue and prices. Free upon request. **Electric Wheel Co., Box 96, Quincy, Ills.**

**BUCKEYE FORCE PUMPS**  
 Are Leaders in the Trade because they work easy, throw a steady stream, do not drip, do not freeze, but **PLEASE ALL WHO USE THEM** They are made to pump and to last, and they do both. The complete embodiment of pump goodness. Write for circulars. **MAST, FOOS & CO., 24 River St., Springfield, Ohio**

**Rife Hydraulic Engine**  
 Pumps water by water power. No attention—NEVER STOPS. Put in place of **RAMS, WINDMILLS, GAS AND HOT AIR ENGINES.** Catalogue free. **POWER SPECIALTY CO., 126 Liberty Street, NEW YORK.**

**FIRE, WEATHER, and Lightning Proof**  
 Black, painted, or galvanized metal **ROOFING** and siding; (brick, rock or corrugated) **Metal Ceilings and Side Walls** in elegant designs. Write for Catalogue. **The Penn Metal Ceiling and Roofing Co., Ltd., 23d & Hamilton Sts., Phila., Pa., or 24 Hancock St., Boston, Mass.**

**Perfect Butter**  
 —the kind which brings the highest price in any market can only be made from perfect milk. All bad odors and flavors of animal, feed or stable must be removed. **THE PERFECTION Milk Cooler and Aerator** will do it quickly, cheaply and perfectly. Made in various sizes from 1 to 200 cows. Send for prices and catalogue of Farm and dairy supplies. **L. R. Lewis, Mfr., Box 19, Cortland, N. Y.**

**WHERE GOES YOUR MONEY**  
**WHEN YOU BUY FENCE?** Lots of it goes into the dealer's pocket. Why not save that amount? How? Buy your fencing from us. We sell the **ADVANCE FENCE** direct to the farmer at wholesale. The dealer can't buy it any cheaper than you can. It is equal in quality to the highest priced fences on the market. Completely interwoven—no loose ends to unravel. Circulars and discounts free. **ADVANCE FENCE CO., 116 Old St., Peoria, Ill.**

**GEM FULL CIRCLE Baler**  
 Warranted the lightest, strongest, cheapest & fastest Full Circle Baler in the market. Made of wrought steel. Can be operated with one or two horses. Will bale 10 to 15 tons of hay a day. Write for description and prices. **GEORGE ERTLE CO., QUINCY, ILL.**

**THE BEST BUTTER** and the most of it is made by using our improved patent **AQUATIC CREAM SEPARATOR.** It takes all the cream out of milk, expels all foul odors and impurities in two hour's time. Better than any creamery made and costs less than half as much. For 1 cow up to 40. Can't get out of order. No experience necessary. Prices, \$5. to \$11. Free catalogue and testimonials. **Reliable Agents Wanted.** **Aquatic Cream Separator Co., 125 Factory Sq., Watertown, N. Y.**

**Soon Saves Its Cost. A 12-Year Old Boy**  
 A Labor Saver, can do more and better work, either in the field or garden, with the **HAND CULTIVATOR** than three men can do with common hoes. Plows, hoes, cultivates—astride or between rows. If no agent in your town send \$1.35 for sample delivered and terms to agents. **Ulrich Mfg. Co., 43 River St., Rock Falls, Ill.**

**FENCE! STRONGEST MADE.** Bull-strong. Chicken-tight. Sold to the Farmer at Wholesale Prices. Fully Warranted. Catalogue Free. **COILED SPRING FENCE CO., Box 18, Winchester, Indiana, U. S. A.**

**DON'T SET HENS THE SAME OLD WAY**  
 The Nat'l Hen Incubator beats old plan 3 to 1. Little in price, but big money-maker. Agents wanted. Send for catalogue, telling how to get one free. **Natural Hen Incubator Co., B. 22, Columbus, Neb.** A. Edwards writes, "Would not take \$100 for N. H. I. Plan."

**\$2.75 buys a MAPLE AND BABY Carriage**  
 \$5.00 Buys a Beauty complete with rubber tire, wheels and paragon seat. Seats of Sleeping Coaches and Coaches. 48 page Catalogue Free. Address Dept. 11 **VICTOR MANFG. CO., 161 to 167 Plymouth Place, CHICAGO, ILLINOIS.**

**DEATH to LICE** on hens & chickens. 64 p. Book Free. **D. J. Lambert, Box 303, Apponaug, R. I.**



## VETERINARY

CONDUCTED BY DR. H. J. DETMERS

To regular subscribers of the FARM AND FIRESIDE answers will be given through these columns free of charge. Where an immediate reply by mail is desired the applicant should inclose a fee of one dollar, otherwise no attention will be paid to such a request. Inquiries should always contain the writer's full address. Queries must be received at least TWO WEEKS before the date of the issue in which the answer is expected. Veterinary queries should be sent directly to DR. H. J. DETMERS, 1315 Nell Avenue, Columbus, Ohio.

NOTE.—Parties who desire an answer to their inquiries in this column must give their name and address, not necessarily for publication, but for other good reasons. Anonymous inquiries are not answered.

**A Dry Teat or Quarter.**—L. H., Canadian, Tex. If one teat or quarter of the udder of your cow is dry and shrunken the best you can do is to leave it alone and to attend to the milking of the other three yet healthy.

**A Lamé Horse.**—J. H., Miller, S. D. Your description, really no description at all, is so indefinite that from it it cannot be made out whether the swelling just above your horse's hoof is ring-bone or quittor. Have your horse examined by a competent person.

**Probably a Case of Tuberculosis.**—G. A. C., Parkerville, Kan. According to the symptoms as you describe them, it is most likely that your Jersey cow is suffering from tuberculosis, and is already in a very advanced stage of that fatal disease. Have her examined by a veterinarian.

**Possibly a Case of Tuberculosis.**—A. E. H., New Salisbury, Ind. What you describe may possibly be a case of tuberculosis. I do not say that it is, but I say this: there is just enough suspicion to make it advisable to subject the cow to the tuberculin test, and thus to secure the diagnosis as early as possible.

**Garget.**—M. E. R., Valley Falls, Kan. What you describe are periodical attacks of garget. Milk oftener and you will have no more trouble. This will be the more necessary since your cow, as you say, gives a large quantity of milk. Keep up the more frequent milking regularly as long as your cow is in full milk.

**Flaxseed-meal.**—C. L., Moline, Ill. It is not known to me that flaxseed-meal or linseed-meal, powdered flaxseed or flaxseed-oil cake, provided the same are neither spoiled nor moldy, will have the effect of causing barrenness in cows or heifers, but it is claimed that cottonseed-oil cake if fed to cows with calf will cause abortion.

**Perhaps Asthma.**—W. J. L., Wheeling, W. Va. The whole description you give of the disease of your dog is contained in the words, "My dog having such a hacking cough." Coughing is a symptom common to a large majority of respiratory disorders, consequently one upon which alone no diagnosis can be based. Perhaps your dog is old and fat, eats well and has no exercise, and in consequence is short-winded and asthmatic.

**Death of Two Cows.**—M. H., Nottingham, Ohio. Your first cow, which went three weeks over time, had the dead calf, and from which the calf had to be taken away, undoubtedly died of metritis (inflammation of the uterus). The cause of the death of the second cow does not proceed from your statement—that she died four hours after calving—the only one you make in regard to her. If you had given any symptoms and correctly described them it might have been possible to make a diagnosis.

**Had Distemper.**—K. O. M., Conoquenessing, Pa. If your colt, nineteen months old, had distemper two months ago, and has not yet recovered, the course of the disease must be and must have been an irregular one, and I have no means of knowing what morbid changes may have been produced in two or three months, so that it would be a very precarious thing to prescribe for such a case. Therefore, the best I can do is to advise you to have your colt examined and treated by a good veterinarian, especially as there is no lack of good veterinarians in your state.

**A Sore and a Black "Spot."**—J. R. F., Huntington, Vt. If your horse, twelve years old, is a gray it is highly probable that the sore over the sacrum, which you are unable to bring to healing, and the black and oval raised "spot" on the shoulder are semi-malignant tumors, known as melanocarcinoma. If such is the case, the treatment consists in leaving them severely alone and in not irritating them in any manner whatever. If this treatment is adhered to such tumors may remain unchanged, or nearly unchanged, for years, but if interfered with or irritated they are bound to become malignant and to resent any interference with a vigorous growth. If extirpated, even if it is done in a thorough manner, usually others will make their appearance very soon in other places; and if it is not done in a thorough manner the tumor will show a vigorous growth and in a short time be more than twice as large as before. If the "sore spot" over the sacrum is not a melanocarcinoma, and a spinous process of one of the sacral vertebrae is not involved, you will soon effect a healing if you apply twice a day a little iodoform, or once a day a little calomel. If, however, there is a carious spinous process, the carious part must either be removed by a surgical operation or be brought to exfoliation before any healing can be effected.

**Concerning Actinomyces.**—J. H. B., Wiser Whatcom, Wash. 1. Actinomyces is not contagious, but infectious. The actinomyces are introduced into the animal organism with the food through sores and lesions, either in the skin or in the mucous membranes. 2. The actinomyces, microscopic organisms of a low order, somewhere between bacteria and fungi, constitute the cause. 3. Actinomyces being a strictly local disease, and not general or affecting the whole organism, cannot affect the milk unless it should have its seat in the mammary glands, and such a case is unknown to me, and as far as I have been able to learn has never been observed.

**A Dead Steer.**—H. J. K., Fallow, Mont. If your description is to be taken literally, and if you found the blood accumulated beneath the skin around the kidneys and in the liver, and in all three places distinctly divided in two parts—namely, in coagulated blood and blood serum or a yellowish watery fluid—the only conclusion that can be drawn is that your steer died of hemorrhage in the parts named, and the short duration of the sickness, only about three hours, would not contradict this conclusion. But if it is correct, your description of the case altogether fails to furnish any data to enable me to form any idea concerning the probable cause of the hemorrhage.

**Feels Itchy When Warm.**—W. H. P., Genoa, Neb. According to your description there are several possibilities. 1. It may be that your horse has an unclean skin and is shedding his coat of hair. 2. It may be that in grooming the horse a curycomb is used which scratches the perhaps extraordinarily sensitive skin of the animal and thus increases the irritability of the same. A curycomb should never be used on the body of the horse, but only to remove the dust and epidermic scales from the brush. 3. It may be that the skin of the horse is irritated by parasites; for instance, horse-lice or chicken-lice. There are some other possibilities, but they are rather remote and therefore may not need to be mentioned.

**No Rabies.**—S. M., Corydon, Ind. Your dog is probably of a nervous disposition, but the peculiarities you describe are no symptoms of rabies, nor is there any danger that your dog will contract that disease unless the same should be bitten by a rabid animal. Rabies is most decidedly a specific disease that cannot make its appearance in any animal unless that animal has first been inoculated with the virus of rabies either by being bitten by a rabid animal or otherwise. If to-day all rabid animals and all animals already infected everywhere on the whole globe wherever they may exist the disease would be wiped out and never would reappear again. In fact, it would be and remain a thing of the past.

**Thrush.**—W. A., Hays City, Kan. What you describe appears to be a case of inveterate thrush. First cut away with a sharp hoof-knife all the loose, rotten and decayed horn, and clean out every crevice in the frog and in the sole of the foot. This done, hold up the foot as for shoeing, but in such a way that the toe of the hoof is considerably lower than the heel of the same. Then, while the foot is held in the position stated, pour some pure carbolic acid (ninety-five per cent) into all the recesses and crevices of the frog and sole in a sufficient quantity to make it run off at the toe. Special care must be taken to bring the carbolic acid in contact with nothing whatever but the frog and the sole of the hoof. Keep the hoof in the described position until no more of the acid runs off, then allow the animal to set down its foot, but only on a clean and level floor. The floor of the stall in which the animal is kept must also be clean and level, and must be kept clean and level. If this is neglected the treatment will be in vain. If, as in your case, the thrush is of long standing, the treatment in a few days will have to be repeated, and the animal must be kept on a clean and level floor until a perfect healing has been effected, which will be in a comparatively short time.

**Bloody Milk.**—E. U., West Casco, Mich. Bloody milk, or the presence of blood or hemoglobin in the milk, as has been often explained in these columns, may be produced by a large variety of causes. Again I will mention some of the most frequent ones. 1. It is quite often observed during the first two weeks after calving, and being caused by physiological processes will disappear without any treatment. 2. It can be a result of congestion or inflammation in the mammary glands, produced either by external injuries or violence, by rude milking, violent sneezing (by the calf), etc. 3. It may be the result of an extraordinary congestion in the mammary glands each time the cow is in heat. 4. It may make its appearance if resinous substances are either given as medicine or being contained in the food, consumed with the latter. 5. It occurs in certain infectious diseases, especially such as will terminate in hemoglobinemia. 6. It may make its appearance also if a sudden change of food takes place, particularly if the new food is very rich in nitrogenous compounds; for instance, composed of rich clover or other leguminous plants. 7. It is not seldom an attendant of tuberculosis in the mammary glands. To determine the cause in each special case requires a careful examination and a thorough investigation of the existing conditions.

**It Is the Old Wool Hair.**—W. J. R., Liberty, Mo. When a sheep is sheared it is, unless seriously damaged or diseased, the old, cut-off wool hair that grows again, and the quality of the new wool will again be essentially the same, unless the health and nutrition of the sheep is interfered with while the new crop of wool is growing. Sickness and poverty have a very detrimental influence upon the quality of the new crop of wool. This, however, does not exclude the possibility of an occasional production of some new wool hairs, but a shedding of the whole coat, as in horses and cattle, does not take place if sheep are regularly sheared, while to a certain extent such a process may be observed if the shearing is not attended to or entirely neglected. If otherwise sheep lose their wool, a skin disease, usually scab, is at the bottom of it.

**Septic Endometritis.**—R. C., Russellville, Ky. Symptoms like those you describe are observed in cases of septic endometritis (inflammation of the uterus, caused, for instance, by a retention and subsequent putrefaction of the afterbirth, or of a portion of the same) if, as is sometimes the case, attended with tetanic spasms. Such cases are comparatively rare, but probably not as rare as generally supposed, because such cases, it seems, have been confounded with, or been mistaken for, puerperal paralysis by a good many writers. Your cow, of which you say that she was otherwise healthy, but did not clean properly after calving, unless she has died before this, will very likely have perfectly recovered when this reaches you, so that nothing will need to be done. If, contrary to expectation, she should not have recovered, but should yet show symptoms of an existing inflammatory process in the uterus, and be subject to tetanic spasms, or fits, I advise you to irrigate her uterus twice a day with a one-per-cent solution of creolin in milk-warm water. This is best done in the following way: Take a common wooden pail or bucket, such a one as can be bought for twenty or twenty-five cents in nearly every grocery-store, bore a smooth one half or seven sixteenths inch hole through the bottom, insert through this hole a glass tube about five or six inches long in such a way as to make an air-tight joint, and the upper end of the glass tube to be flush with the upper surface of the bottom of the pail; then get from six to eight feet of rubber tubing of suitable diameter, shove one end of the rubber tubing over the free end of the glass tube projecting from the lower surface of the bottom of the pail, and then carefully insert the other (free) end of the rubber tubing as far as you can without using force into the uterus of the cow. This done, raise the pail or bucket as high above the cow's back as convenient (perhaps suspend it from a convenient beam), and then pour into it from a quart to half a gallon of your milk-warm creolin solution kept in readiness and at hand. The fluid by its own weight will then gently flow into the uterus and thoroughly irrigate it. Repeat these irrigations twice a day until all abnormal discharges from the uterus have ceased.

**Heaves.**—C. A., Brighton, Mich. As has been repeatedly stated in these columns, the term "heaves" does not signify any definite or specific disease, but is applied to any chronic, feverless and incurable difficulty of breathing, caused by irreparable morbid changes of various kinds existing somewhere in the respiratory apparatus and organs of circulation. In the eastern and western states of the United States the most frequent immediate cause consists in morbid changes in the bronchi and in the walls of the air-vesicles of the lungs, brought about by feeding too much musty and dusty hay—that is, hay extensively contaminated with fungi and fungous spores. Although so-called "heaves" is incurable, considerable relief will be given to the affected animal if the following rules are strictly followed: 1. No tame hay, especially if it is in the least dusty, must be fed; limited quantities of bright and sound wild hay, sheaf-oats, cut when yet green or half ripe, or clean and bright oat straw must serve as a substitute, and the loss thus caused in the supply of nutrient elements must be made up by feeding increased quantities of grain of a good and sound quality. 2. But very moderate quantities of any kind of voluminous food must be fed, so that stomach and intestines will never become filled up to such an extent as will cause them to press upon the diaphragm and thus diminish the space in the chest required for the process of respiration. 3. The horse must never be allowed to become costive, and any inclination to costiveness must be promptly removed by feeding a good bran-mash. 4. At least one hour's time of rest after each meal should be granted to a horse affected with heaves before the same is hitched up for any kind of work. 5. If such a horse is kept in a stable, the latter must be kept clean and well ventilated, so that the air for breathing is always fresh and pure; and as it is often difficult to secure good and fresh air in some stables, it may be advisable to give such a horse the coldest place or a place close to the door. 6. Good and diligent grooming, because increasing the activity of the skin, and thus relieving the functions of the lungs, is also advisable. For the same reason a horse affected with heaves should never be employed for work that requires speed, and thus causes profuse perspiration.

## FREE

### A WONDERFUL SHRUB—CURES

# KIDNEY AND BLADDER

## DISEASES, RHEUMATISM, ETC.

Rev. A. C. Darling, Minister of the Gospel, under date of May 20th, writes from his home at North Constantia, Oswego county, New York:

I have been troubled with Kidney and kindred diseases for sixteen years, and tried all I could get without relief. Two and a half years ago I was taken with a severe attack of La Grippe, which turned to pneumonia. At that time my Liver, Kidneys, Heart and Urinary Organs all combined in what to me seemed their last attack. My confidence in man and medicine had gone. My hope had vanished, and all that was left me was a dreary life and certain death. At last I heard of Alkavis, and as a last resort I commenced taking it. At that time I was using the vessel as often as sixteen times in one night, without sleep or rest. In a short time, to my astonishment, I could sleep all night as soundly as a baby, which I had not done in sixteen years before. What I know it has done for me I firmly believe it will do for all who will give Alkavis a fair trial. I most gladly recommend Alkavis to all. Sincerely yours,

(Rev.) A. C. DARLING.

The venerable Mr. Joseph W. Whitten, of Wolfboro, N. H., at eighty-five years of age also testifies to the powers of Alkavis in curing severe Kidney and Bladder Disorders, Dropsy and Rheumatism. Hundreds of others give similar testimony. Many ladies also join in testifying to the wonderful curative powers of Alkavis in Kidney and allied diseases, and other troublesome afflictions peculiar to womanhood, which cannot with propriety be described here.

That you may judge of the value of this Great Discovery for yourself, we will send you one Large Case by mail free, only asking that when cured yourself you will recommend it to others. It is a Sure Specific Cure and cannot fail. Address The Church Kidney Cure Company, No. 471 Fourth Avenue, New York City.

### Labor-saving Conveniences

Success on the farm to-day is largely proportioned to the saving of time and labor—which means economy of production—and not higher prices for farm products. Probably no single machine or appliance saves in the aggregate so much time and hard labor as the modern low-down bandy wagon. Take, for instance, the load-

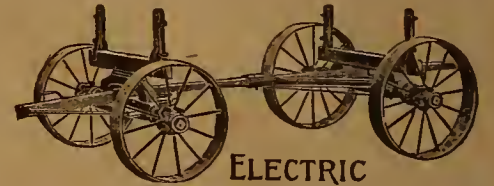

ELECTRIC

ing and hauling of manure, ensilage corn, grain in the straw, corn fodder, hay, etc., all hard to load, the use and advantages of a low-down wagon are almost inestimable. The Electric Low-Down Handy Wagon excels for these purposes. Has the famous Electric steel wheels, is light, strong and durable. Write Electric Wheel Company, Box 96, Quincy, Illinois, for catalog.



### RIDER AGENTS WANTED

One in each town to ride and exhibit sample 1900 bicycle  
1900 Models, best makes, \$11 to \$20  
'99 & '98 Models, high grade \$8 to \$13  
500 Second-hand Wheels  
all makes and models, good as new,  
\$3 to \$10. Great Factory Clearing  
Sale at half factory cost. We ship  
anywhere on approval and trial with-  
out a cent in advance

EARN A BICYCLE distributing  
Catalogues for us. Many earned  
a wheel last year. Our 1900 propo-  
sition is even more liberal  
Write at once for our Bargain List  
and special offer. Address Dept. 43 B,  
MEAD CYCLE CO., Chicago.

WE HAVE HUNDREDS OF MEN AND WOMEN MAKING

## \$25.00 A WEEK

EASY and steady work, home or traveling, selling

### BRADFORD'S AUTOMATIC WASHER

Does complete washing, from fine laces to heavy quilts, in 15 to 30 minutes, without rubbing. Put the clothes in, machine does the rest. Cheaper, cleaner, better than old-style back-breaking washboards and machines. Positively the best-selling, most legitimate article on the market. Mr. Hallinan, of N. Y., sold three dozen first week. Mr. Bubb, of Ind., made \$12 in one day. Miss Stevens, of Tenn., \$138 a month. Everybody wants one when they see it work. Many making \$50 a week WHY NOT YOU? Write to-day for how to get an Agent's Sample Free. We start you in business. No scheme, fraud or fake method. Address BRADFORD & CO., B-40, CINCINNATI, OHIO.

## \$83.33 Monthly Salary

payable weekly with expenses.  
Men or Women to represent us  
in their own state. Your  
duties to take charge of solicitors and attend to  
collections. NO INVESTMENT REQUIRED.  
This is a strictly bona-fide salaried proposition.  
IT INVOLVES NO CANVASSING whatever.  
Expenses will be remitted in advance and salary  
forwarded directly from headquarters. State  
experience. Give references. Enclose stamp.  
CO-OPERATIVE CO., 110 Star Bldg., CHICAGO.

\$5 BICYCLES CHEAPER THAN EVER  
from the OLD RELIABLE CO. Great Special  
Sale. Nearly 8000 Bicycles, every one a  
BARGAIN. Must be sold. All makes, 2nd  
h'ds. \$5 and up. Late Models new \$11.50  
and up. Shipped anywhere on approval. A  
few more good agents wanted. Big money.  
Write to-day for big list and special offers never  
before approached. BROWN-LEWIS CO.  
Dept. (J) Chicago, U.S.A.

## FREE SCHOLARSHIP

IN Electrical, Mechanical, Marine, ENGINEERING  
Stationary or Locomotive  
NUMBER LIMITED. WRITE IMMEDIATELY  
AMERICAN SCHOOL OF CORRESPONDENCE, Boston, Mass.

BARGAINS 25c. Scroll-Saws, 6c.; 25c. Belts, 9c.; 25c.  
Novels, 4 1/2c.; Boys' Suits, 89c.; Men's  
\$2.25 Shoes, 98c.; Best Skirt-Binding, 1 yard, 13c.; Gold Scarf-  
Pin, 1c.; 5c. Ribbon, yd., 1 1/2c.; Washing-Powder, pkg., 2 1/2c.; Men's  
Linen Collars, 3c.; Dress-Buttons, dozen, 1c.; Silk Lace Mitts, 6c.;  
Large pkg. Snoking-Tobacco, 3 1/2c.; Men's Wool Hats, 29c.; Boys'  
Wool Hats, 19c.; Good Calico, yd., 3 1/2c.; Good Shears, 3c.; Pins, paper,  
1c. Send for list, 1000 bargains. C. A. Willard Co., Chicago, Ill.

### LADIES TO DO PLAIN SEWING

at home, \$1.50 per day, four months' work guaranteed.  
Send stamped addressed envelope for full particulars.  
R. W. HUTTON & CO., Dept. 3, Philadelphia, Pa.

WANTED AGENTS in every county to sell "Family  
Memorials," good profits and  
steady work. Address Campbell & Co., 158 Plum St., Elgin, Ill.

## PLAYS

Dialogues, Speakers, Amusement  
Books, Catalog free. T. S. DENISON,  
Publisher, Dept. 5, CHICAGO.



THE GRANGE

Conducted by MRS. MARY E. LEE, New Plymouth, Ohio

IF CORRESPONDENTS will observe the following suggestions a great deal of delay and trouble will be saved: Always give your name and address when writing to us. Sign any nom de plume you like to your inquiry or article, but invariably inclose your name. Always give your county as well as post-office address when writing. Address all communications intended for this department to the address as given above, and not to the Springfield office. If these simple rules are observed your inquiries will have prompt attention.

\*\*\*

We have often urged, on this page, the plan of getting outside speakers to visit and talk to the grange. We believe this is one of the best ways of making a grange a live, progressive organization. Bring in new blood, new ideas, new methods of expressing thought. At one meeting invite a banker or business man to speak on business principles and practices. At another get a lawyer to deliver a lecture on our common law. He will elucidate many things that will save farmers many dollars. The student of history has a wide field to wander in, and at no point could the interest wane if the speaker has a magnetic presence. A lecture on American literature and American authors would stimulate a love for our own authors and awaken an enthusiasm for better literature. It would do more to draw our young people's attention to purer reading matter than all the philippics we could pronounce against trashy reading. A lecture on the geological formation of your county might bring thousands of dollars into your pockets. I recall an instance of this kind in my own state. Prof. Chapin, of the Ohio University, studied the soil of Athens county and found it peculiarly adapted to peach-growing. He interested farmers in the matter, and as a result peach-growing has become a leading and profitable industry in that county. Possibly you are not near enough to a college or high-school town to make it practicable to secure members of the faculty. Fortunately the neighborhoods are few indeed that do not possess some college man or woman or an intelligent person who has made a particular study of some branch of learning of peculiar interest to him. Ask him to lecture before your grange. It will please him and help you. A gracious woman who has the tact to put all at ease in her presence could give a valuable talk on social observances. Other subjects will suggest themselves to you. Many of these people will gladly give you an afternoon or evening out of their busy lives. An education makes one anxious to help others, and stimulates the noble, generous impulses natural in youth. Such a course of lectures will relieve the monotony of hearing the same persons talk, add new interest and zest to life, awaken dormant curiosity, bring new ideas, new aspirations and longings to each individual, and by extending our interests and sympathies hasten the glad day.

"That man to man, the world o'er,  
Shall brothers be for a' that."

\*\*\*

We are becoming accustomed to scandal. We look for it in our daily paper as a matter of course, and are surprised if we do not find some new example of culpability set forth in all its glaring details. Many public men are callous to public opinion. "We are no more corrupt or dishonest than those who elected us," say they. "If our constituents had the opportunity they would do as we do. They practise their deceits on the small scale natural to their abilities. It is lack of sense, not supersensitiveness of conscience, that makes men fairly honest. They are afraid to do what they want to do. We are brave and fearless. We paid our way into the show, and we will get our money's worth. Honor and truth are legendary virtues. Possibly they were distinct entities in some far-distant past. We are quite sure they have no place in our life to-day. To those gentlemen who advertise us, thanks. You, too, have

your price, as have all other men. It shall be our business to find your worth and pay you at your own rating. Meanwhile we will take what we can, for there are bigger rogues than we climbing the ladder. They will soon dislodge us. They talk reform, and denounce us. The only reform they desire is to exchange places with us. But we will give them a lively fight."

So reason some men prominent in local and national political affairs. That they represent the spirit of the age I emphatically deny. They are the Corbetts and Fitzsimmons in the political arena. They are no more representative of the thought of to-day than are the afore-mentioned gentry. It is true that by playing on the passions and prejudices of mankind, by promises and protestations of loyalty to the right, to the better element, and by protecting the vicious element in its pursuit of vice and debauchery, they have acquired power and prestige. But when caution gives way to bravado, and they brave the wrath of an outraged public, then do they seal their own doom. There have been several prominent examples of this. There will be many more as the people grow in civic intelligence and learn to think for themselves. On the other hand, no nation of all time has produced men of keener intellects, broader sympathies or stricter integrity than we have in our own public life to-day. Men are loyal to their country's interests who regard their honor as a priceless heritage, to be handed down to their children's children; who are human enough to be practical, and divine enough to be honest. They are not those whose names are on every one's lips or the common property of the corner grocery and the saloon. They are the ones who are quietly shaping the destiny of our nation; who diligently study the problems confronting us. When they speak, never did Delphic oracle have more attentive audience. Men listen because they are sincere, and are convinced by the cogency of their reasoning. Never were such men needed so much as now. Never did a nation have so momentous questions to solve. Never did so much depend on the solution.

\*\*\*

We are on the eve of what promises to be the most hotly contested election America has ever seen. Charges and counter-charges of evil designs and corruption will be made. Much of it will be true. Perhaps not a half will be told. But in the midst of the din do not forget to listen to the voice of reason. Do not shun the voice of statesmen to listen to that of the politician, and always remember "They enslave their children's children who make compromise with sin."

If we honestly endeavor to study the problems unbiased by partisan influence; if we use our influence, silent though it may be, for justice; if we are willing to divorce ourselves from thoughts of legendary virtue, and grimly face the present issues, I doubt not time will render to us the need of heroism. Let us not lose faith in humanity.

\*\*\*

"To-day is a king in disguise." To-day always looks mean to the thoughtless, in the face of a uniform experience, that all good and great and happy actions are made up precisely of these blank to-days. Let us not be so deceived. Let us unmask the king as he passes. Let us not inhabit times of wonderful and various promise without divining their tendency. Let us not see the foundations of nations and of a new and better order of things laid with roving eyes and an attention preoccupied with trifles.—Emerson, in "Lecture on the Times."

\*\*\*

"Many are not aware that we are living in extraordinary times. Few suppose that these years of peaceful prosperity, in which we are quietly developing a continent, are the pivot on which is turning the nation's future. Fewer still imagine that the destinies of mankind for centuries to come can be seriously affected, much less determined, by the men of this generation in the United States. But no generation appreciates its own place in history. Several years ago Professor Austin Phelps said, 'Five hundred

years of time in the process of the world's salvation may depend on the next twenty years of United States history.'"—Dr. Josiah Strong, in "Our Country."

\*\*\*

"New occasions teach new duties; Time makes ancient good uncouth; They must upward still, and onward, who would keep abreast of Truth; Lo! before us gleam her camp-fires; we ourselves must pilgrims be. Launch our Mayflower, and steer boldly through the desperate winter sea, Nor attempt the Future's portal with the Past's blood-rusted key."

—James Russell Lowell, in "The Present Crisis."

\*\*\*

Few people realize what the grange means to the farmer, nor foresee the place it will occupy in history. In training him in business methods it increases his financial status, thus enabling him to enjoy the comforts and luxuries of life, and through increased power of thought and ability to enjoy extends his influence in the world. It urges upon him the use of machinery and improved methods of agriculture, to the end that he may more economically produce his crops. Through the trade arrangements made by the executive committee he is enabled to buy and sell independent of several middlemen, thus saving to himself the profits that would accrue to this class. It has enabled him to secure just legislation. It has made him a power in the land. He has not secured entire justice. No class has done that, nor can it do so till human nature has less of the human element in it. But that it has changed the condition of the farmer from that of a practical nonentity in political affairs to an influential factor, giving him a place in the cabinet, meting out to him recognition in the halls of state and nation, giving him a social place in the nation, speaks volumes for the wise conservatism of its leaders. That it has, in the short space of a quarter of a century, placed the farmer in an enviable position, and amidst rumors of vice and corruption kept alive the spark of independence, integrity and sturdy determination, is worthy of profound gratitude. What it would accomplish with a large per cent of the wide-awake, better class of farmers in its ranks we can only surmise. With such augmentation of strength and power it would accomplish wonderful results. Its ranks are being filled. Many farmers seeing the advantages of organization are uniting with us, because they know that our order has stood the test of time, that it has outgrown the measles and whooping-cough stage, and is on a solid basis. We predict yet greater growth in the next five years. Every grange organized in a community that is determined to maintain it against all obstacles is a distinct gain to that place. It brings those members into the great army of workers who are determined to help themselves, and thus benefit humanity.

\*\*\*

The meeting of the National Educational Association at Charleston, S. C., in July promises to be one of exceptional interest. The Southern people are noted for their hospitality, and they are making every arrangement to fill the hours with interest. Many side trips to famous places are arranged for. The program is excellent. We hope all of our readers who are able to attend will do so. Send us a report of the meetings, that we may all enjoy the treat. For particulars address Prof. Irwin Shepard, Winona, Minn.

HAVE FAITH

Teach the children to look toward the light, have faith in humanity, exercise charity, and thus make the world a brighter place to live. It is too bad to poison the mind of a child, to teach him that women are weak, and that every man has his price. Let the morning meal be enlivened more by conversation about things and less about our neighbors' short-comings, more concerning our personal duty as citizens and less about the dishonesty of public officials. If life is to be worth living it must be bright and full of interest. Let us not teach our children to look always for dishonesty and gloom.—F. A. Derthick.

THAT TOBACCO COUGH!

Smoke and chew, hawk and spit! Throat's always irritated, consumption easily started. Then comes pale, bloodless countenance, glittering, restless eye and ever nervous movement of hands and feet. NO-TO-BAC is a specific for tobacco throat even if you don't want a cure. Take a NO-TO-BAC tablet now and then. What a relief in

NO-TO-BAC



Builds up the nervous system, makes new, rich blood,—just the thing for the weak, nervous man to use now and then. Get our book; read the marvelous record of recovery. You run no risk, for you can buy under your own

DRUGGIST'S GUARANTEE.

Every druggist is authorized to sell No-To-Bac under absolute guarantee to cure every form of tobacco using Our written guarantee, free sample of No-To-Bac and booklet called "Don't Tobacco Spit and Smoke Your Life Away," mailed for the asking. Address THE STERLING REMEDY CO., Chicago, Montreal, Can., New York, 64

CASCARETS candy cathartic cure constipation Only 10c



Dizzy? Then your liver isn't acting well. You suffer from biliousness, constipation. Ayer's Pills act directly on the liver. For 60 years the Standard Family Pill. Small doses cure. 25c. All druggists.

Want your moustache or beard a beautiful brown or rich black? Then use BUCKINGHAM'S DYE for the Whiskers. 50 CTS. OF DRUGGISTS, OR R. P. HALL & CO., NASHUA, N. H.

HOME-SEEKERS

THOUSANDS OF HAPPY HOMES

If any one contemplates a change of residence he should not overlook the attractions and advantages of Utah. There are thousands of acres of splendid land at various points on the line of the Rio Grande Western Railway in that state. The soil is very productive and the market close at hand. The climate is superb, being temperate the year round. The sugar-beet industry, as well as fruit culture, etc., are prominent features of these agricultural districts. Send 2 cents postage for a copy of "Lands," to Geo. W. Heintz, General Passenger Agent Rio Grande Western Railway, Salt Lake City, Utah.



GARDEN HOSE

at 5 3/4c Per Foot

We bought at Sale 75,000 ft. Brand new, 3/4 inch, 50-foot lengths, with couplings. Write for free Catalog No. 34 on merchandise of all kinds. OUR PRICES ARE ONE-HALF OF OTHERS. Chicago House Wrecking Co. West 35th & Iron Sts., CHICAGO.

\$14 If You Want to SAVE MONEY

and get the best machine at lowest wholesale price, now is your chance. Buy direct from factory, one profit. All attachments free. 30 days' free trial. — WARRANTEED 20 YEARS. \$40.00 Arlington for ..... \$14.00 \$50.00 Arlington for ..... \$17.00 \$65.00 Kenwood for ..... \$21.50 Other Machines at \$9, \$10.50 & \$12. Illustrated catalog and testimonials free. CASH BUYERS' UNION, 153-164 W. Van Buren St., B-7, Chicago, Ill.

WHITE and FANCY RUBBER COLLARS, CUFFS, BOSONS and TIES. Always laundered; Never wilt; can't be told from linen. Mailed anywhere. Fully patented and guaranteed; Agents wanted; exclusive territory; liberal commission. Send 4 cts. in stamps for Samples, Catalog; 150 styles, and terms. M. & M. MFG. CO., Dept. B 8, Springfield, Mass.

Binder Twine FARMERS WANTED AS AGENTS AUGUST POST, Moulton, Iowa.

Mattresses We sell direct to the consumer all kinds of Mattresses at one half the price paid dealers. Write for kind wanted and prices. Acme Mattress Co., Winchester, Indiana.





## IN THE WORLD OF NATURE

**H**ow many mothers can explain the process of digestion to their children? As a youth looks upon the pages of the book of Nature, one after another, he is impressed with the evident and certain adaptation of means to ends. Turning the leaves of that book he comes to the study of man. He finds him composed of solids and liquids—bones, muscles, membranes, brain, marrow, nerves, vessels, blood, and many other things. Adaptation is stamped upon each and all. He is a living organism that maintains itself only by constant supply. The manner of furnishing that supply is called digestion.

The human system hungers; it must be fed or it will perish. It cannot live upon itself, and the imperative demand for food must be supplied from the outer world. The materials for that supply are crude and require many and great changes before they can be made subservient to the life and development of a human being.

The eye searches out the raw material, the fingers manipulate and mix, the tongue tastes and tries, while reason guides the instincts in the selection and preparation of food. It is when eyes and fingers and tongue, with reason and instinct, have done their best and last that digestion begins.

The mouth is the hopper, and the teeth are like the blades of shears, to cut, and like the upper and nether millstones, to grind. While the materials are thus kept in the mouth (or should be) until they can be very finely cut, the glands of the mouth—three on each side, called salivary—furnish a liquid, called saliva, to soften the hard food, moisten the mouth and prepare the food for its final passage down the meat-pipe, or esophagus, into the great receptacle, the stomach. This saliva is a colorless, frothy, alkaline fluid. When hunger ceases and the mouth is empty the stomach is filled with a nutritious alkaline ball. If mastication has been perfect it is homogeneous in character and uniform in appearance.

Now all is quiet for half an hour; this time describes a normal or healthy stomach. During this quiet time the gastric follicles are silently covering the contents of the stomach with an acid substance, called gastric juice; this is a solvent of the alkaline contents of the stomach, and its power is due to the presence of pepsin in the gastric juice. The lactic acid in this juice neutralizes the alkali that was thoroughly mixed with the food in the mouth by the presence of saliva during mastication. When the half hour (or more) has passed a new and peculiar motion of the stomach takes place. It is caused by the contraction and expansion of the circular and longitudinal fibers of the muscular, or second, coat of the stomach, producing a constant motion of the food ball from side to side, or from end to end, until the stomach is empty. This motion is called peristaltic.

As the process of converting the food into pulp in the stomach goes on the lower, or pyloric, orifice, known as the "gate-keeper" of the stomach, opens to let the soft, delicate pulp pass below; but the gate shuts down against any solid substance, and sends it back to be rehandled by the power above—that is, the upper stomach.

This is no theory. While physiologists felt that they understood reasonably well the process of digestion, they were able to verify the theory many years ago. Alexis St. Martin, a Canadian, received a gun-shot wound in the stomach of such a nature that while he regained health there always remained an opening in his stomach about an inch in diameter. Many physicians watched the food from the time it came into the stomach until it all passed out. They compared and measured the time required for the digestion of different articles of diet, and different modes of preparing the same kind of food.

When the food passes into the lesser stomach, or duodenum, the liver pours in its alkaline bile, and the pancreas gives its peculiar fluid, which are then mixed with the acid pulp, and the final great change is wrought and the nutriment is prepared for a being "fearfully and wonderfully made." Digestion is accomplished, and assimilation must do the remaining work.

Digestion takes the heterogeneous materials placed in the mouth, cuts, grinds, mixes, and moistens with saliva, an alkali, and passes the compound down the esophagus, through the cardiac orifice, into the stomach, to be rolled this way and that, acidified and pulped, then sent into the lesser stomach to be molded and refined by the bile from the liver and the pancreatic secretion. This mass or pulp receives back its alkalinity, which was lost in the stomach, and is kept in a mild, soft state for the further action of assimilation.

Assimilation, by its lacteals or absorbents, gathers out all of the nutritious elements and conveys them to the right, inferior part of the spine, into a duct—the thoracic—thence upward, across the spine to the left, and deposits them in the left subclavian vein, thence to the right side of the heart, and on to the lungs, to be oxygenated and sent back to the left side of the heart and out into the arteries, to furnish every fiber of the system a portion in due season.

The saliva of a healthy person amounts in a day to many ounces; has been estimated as high as three, and one half pounds. There is enough to keep the mouth moist and thoroughly saturate the food in the mouth if eating is done as slowly and carefully as it should be. In fast eating there is great danger that unground parts will be forced or washed down, and much more time will then be required to complete the work in the stomach. Another serious effect arises from the food passing into the stomach without carrying with it a natural quantity of saliva. The stomach is injured when it is called upon to do the work of the teeth, and it often fails to respond. Derangements thus extend to other organs, and the way leads to dyspepsia. Indigestion and good health never walk together.

No fixed rules of diet suit every individual. Each within certain limits must be a law unto himself. It has been observed that a variety of digestible articles eaten at any one meal take less time for digestion than an entire meal of some one of the articles. Animal food is sooner and more easily digested than vegetable diet. The reason being that animal substances are more easily fermented, and the central power of digestion is ferment. In the gastric juice it is called pepsin, and of the pancreatic it is pancreatin. There are a few substances which do not require the action of ferment to carry them to the blood. Among these are water, salt and grape-sugar. The relation of cookery to digestion is so close that it makes a worthy study to all who have the family meal in charge. The selection of healthful food stuffs and the proper preparation of the same are among the great things of life.

MARY JOSLYN SMITH.

### THE CARE OF CANARIES

These sweet singers, which so many of us keep to cheer our homes with their sunny presence, need daily and careful attention. Let their gilded prison be kept perfectly clean, using in the bottom of the cage brown paper covered with fine sand if possible. The cage should be thoroughly cleaned every morning. Allow the bird its bath before you clean up its house for the day. It is not well to leave the water in all day, as it becomes foul and gives off disagreeable odors.

The cage should never be hung in the sunshine or a draft of air, as the birds are very susceptible to taking cold, and are predisposed to asthma. This some-

times attacks them during the molting season, and unless great care is exercised this will frequently continue for a great many months. When suffering from this disease leave off feeding them their seed, and feed bread-and-milk paste—made by putting bread into hot milk—a little dash of cayenne pepper or a little minced onion. Into the drinking-water put a very little currant jelly.

Too many people give a great variety of food to their birds. They are much better without it. A regular diet should consist of mixed seed—canary and rape—fresh water and cuttlefish. Do not feed hemp-seed, as this causes a bird to fatten and lays it liable to asthma.

Canaries do not need green food, though occasionally they may have a small leaf of lettuce or a piece of apple.

When they seem drooping feed them sponge-cake soaked in sherry wine.

If they are troubled with mites hang a white cloth over the cage at night and you will find it covered with them the next morning.

Keep the perches clean and well oiled with coal-oil or olive-oil.

If a bird is old sometimes its nails will be very long. These should be carefully clipped, as they curl and harm the feet.

Accustom your bird to being handled, and do not frighten it. It will repay you for your care of it by its bright songs.

B. K.

### RHUBARB AND ITS VIRTUES

Many people who have had rhubarb in their gardens for as long as they can remember think this valuable plant was like "Topsy," and that it just "grewed." But this is not so; it has ancient history, and grew originally on the banks of the Volga, the largest river in Europe. The medicinal rhubarbs are another variety, and I well remember, as a child visiting in a New England family, where the head of the house had no faith in doctors, and whose one remedy for all diseases was, "Chew rhubarb!"

The value of rhubarb on the system, its agreeable acidity, and the many uses to which it may be put, as well as its cheapness, should give it an important place in our late spring and summer menus. The small, red-stalked variety makes excellent coupages and filling for pies and tarts, while the giant rhubarb makes a delicious and healthful drink. In using rhubarb it must be remembered that it contains a large amount of water, and due allowance must be made for this. But with lemon, apple or ginger added, you have a variety of new preserves for your closet.

**RHUBARB JAM WITH GINGER.**—String some rhubarb cut into short lengths, and weigh. Put the fruit into a kettle and add just enough water to prevent burning. When the fruit has become quite soft add sugar, one pound for each pound of fruit. Stir well until the jam becomes rich and syrupy. For each pound of fruit take about a teaspoonful of ground ginger, rub it smooth with a little water, and add it to your jam. Boil up jam again, stirring well, put into glasses, and when cold cover. If a large amount of rhubarb is at command a high grade of brown sugar is very good; the only difference seems to be that the jam is not quite so clear.

**RHUBARB JELLY.**—The best time to make this jelly is when the leaves and stalks are well grown. Wash the stalks, but do not peel, as the pink skin gives an attractive tint to the jelly. Cut the stalks in medium-sized bits, never mind stringing them, and to each pound of fruit allow a cupful of water. Stew gently until a perfect pulp. Strain through a cheese-cloth bag, and to each pint of juice allow a pound of granulated sugar. Let the juice boil for about twenty minutes, add the sugar, and stir until the sugar is quite dissolved. When the syrup is thick turn into glasses, and cover when cold. You have here a very agreeable, pretty jelly, its pale pink tone being unusual and an ornament to any table.

**RHUBARB-WATER.**—A doctor gave me this receipt for a "spring drink." It is very agreeable and refreshing. Take a pound of rhubarb and stew it with a pound of brown sugar. Put it in a jug

and pour over it a gallon of boiling water. When it gets cold pour it through a colander, pressing the fruit, and put back in the jug, but do not cork. Drink cold.

Some housekeepers like to make a little wine each year, and if you have never utilized rhubarb the following receipt may be useful:

**RHUBARB WINE OR CIDER.**—Cut up a quantity of rhubarb-stalks and bruise them with a wooden spoon. Put them in a deep pan, and for each five pounds of fruit pour over a gallon of water. Let it stand for three days, stirring it up two or three times each day. Then strain the liquor, press the fruit through a sieve, and put with it three and one half pounds of brown sugar to each gallon of liquor and fruit. When the sugar is quite dissolved put it in a cask and let it work. Put into a bag of cheese-cloth about an ounce of isinglass (if you have about ten gallons of liquor), and cork up the cask tightly. At the end of six months draw off, bottle, tie down corks, and after leaving the bottles standing up for about a month lay them on their sides. A delicate drink served with ice.

**RHUBARB JELLY WITH APPLES.**—If you are fortunate enough to have some good cooking-apples left by the time rhubarb is well grown this is a good receipt to use: Skin and cut into bits five pounds of rhubarb. Add to it three pounds of cooking-apples peeled and quartered, the juice of six lemons and the grated peel of one, and two pints of water. Stew them together gently until they are a pulp, then strain through a cheese-cloth bag. For each pint of juice use a pound of granulated sugar, let it boil, skim carefully, and when it will "jell" when dropped on a saucer take it off. Pour into glasses and cover.

1

### MILDEW ON SWEET-PEAS

For the first time in an experience extending over several years we have had trouble with our sweet-peas. The past summer they were nearly destroyed by mildew, and as we have never seen any mention of this trouble in the floral papers we thought perhaps our experience might be of interest to some of your readers.

In the early part of July, just as the sweet-peas were in their prime, we had a week of very cloudy weather, with rain and mist every day. We gathered all the opened flowers Saturday at noon, and did not notice anything wrong with the vines at that time. When we went to pick the peas Monday morning, however, we noticed that the vines were covered all over with a powdery mildew, in appearance much like that which comes on the garden-pea. We noticed, also, that there were no half-opened buds, and a closer examination showed that the buds had all been blighted when very small. The mildew had so covered the vines that there seemed little hope of saving them, but we determined to try. We purchased a little potassium sulphid (or liver of potash, as it is commonly called), and procured a small spraying-pump. The potassium sulphid was dissolved in water, in the proportion of one half ounce to the gallon, and the vines thoroughly sprayed with this. The effect of this treatment was soon seen in the improved appearance of the vines; but as potassium sulphid is transient in its action, and to make "assurance doubly sure," we sprayed them the next day with Bordeaux mixture. As it is hard to make spraying solutions adhere to pea-vines, we added to the Bordeaux mixture a portion of the "resin-lime" mixture described in the bulletins and reports of the New York experiment station. The vines kept improving, and in five days had begun blooming again, and the blossoms were soon as profuse and large as ever, although the stems were not so long as before the attack of mildew. We feel sure that had not vigorous measures been taken the sweet-peas would have been entirely lost, and if any of your readers have trouble with mildew we recommend giving spraying a trial. Probably the potassium sulphid is all that is necessary. Were we to use a copper solution again we should prefer the ammonia-copper carbonate solution (cupram), as that does not stain the flowers.—Vick's Monthly.





Copyright 1900 by THE PROCTER & GAMBLE CO., CINCINNATI

### ON THE LINKS

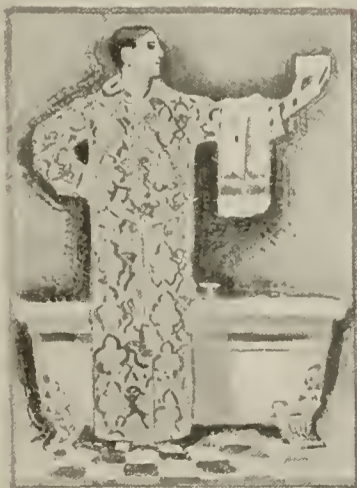

The pleasure and benefit of healthful exercise are increased and made more permanent by the bath which follows. Ivory Soap, because of its purity, its mild creamy lather and the comfortable feeling of perfect cleanliness that results from its use, is the soap most generally preferred for the bath. It floats.



Any person wishing a copy of this picture may mail to us 10 Ivory Soap wrappers, on receipt of which we will send a copy (without printing) on enamel plate paper, 14 x 17 inches, a suitable size for framing. THE PROCTER & GAMBLE CO., CINCINNATI.







WHEN THE BOY GOES FROM HOME

He is almost sure to go some time or another, for a longer or a shorter period. It may be his absence will be for only a few days, on a visit to friends. Or it may be he will go away to school at such a distance from home that he will be gone several weeks or even months. Or perhaps his going away will be to begin business for himself, his return being a matter of uncertainty. But whatever may be the cause of his absence, there are some things the mother will be quite sure to think of. One of these things relates to her son's clothes. How the boy's clothes do worry the mother! She knows how easy it is for accidents to happen. An unexpected tramp in the fields; a challenge to climb some tree; a jumping-match, or perhaps the plain wear and tear of every-day life, and the boy suddenly awakens to the humiliating fact that something has gone wrong with his clothes, and mother, like the famous Sheridan, "twenty miles away."

If, when these trying times overtake the lad, he can go to his satchel or trunk and take out needle and thread and sit calmly down to the task of repairing the damage his coat or trousers have sustained, he can rejoin his companions a little later with countenance as bright and shining as ever. But suppose he cannot do this! Think of the disgrace! He must appeal perhaps to some total stranger! Life loses its charms. The torn garment becomes a burden. He contemplates suicide or something terrible.

Then, fond mother, see to it that the boy is well supplied with the articles necessary to enable him to hold up his head amid the untoward circumstances which are so likely to overtake him. And not only that. When he is young, ere the evil days come, teach the boy how to use these helpful articles. It is not a thing to be ashamed of that the boy should be able to handle the needle skillfully. When he is small he will take to this kind of work just as handily as will his sister. I know of a boy who when a little fellow pieced a large number of blocks for a bed-quilt. The work was done under the direction of his mother, and was altogether a very commendable job. That lad is perhaps now just a little sensitive when the subject of his early taste for sewing is under discussion; but I have reason to know that he has many times since been thankful that he was taught to do such work. It has saved him not a few cents and a great deal of vexation now that he has gone away from home.

Probably there is not a man living who has not in moments of genuine sorrow wished that "some one would invent a button that never would come off." But as yet the problem is unsolved; and how often are we members of the sterner sex suddenly compelled to admit that it "is too warm for us" in the room, and back as gracefully out as we can, to go away into solitary and truly soul-rending meditation, while we sweat and growl and prick our fingers in the attempt to put in place the button which is the cause of all our trouble? No language yet devised can properly express a man's feelings on such occasions as this. But how satisfying to be able to sit quietly down and sew the offending thing on without once drawing blood or provoking our souls to anger! Then, and perhaps only then, can we fully understand what it is to be angry and sin not.

Then see to it that the boy has plenty of buttons, and that he knows how to put them where they will do the most good. Stockings no man can mend. Do not expect it of him. As long as there is such wide-spread, and deep-felt antipathy on the part of the feminine portion of humanity against this undoubtedly necessary occupation let no woman even hint that any man ought to "darn his own socks!" He simply cannot do it. The mysteries are too great. I for one am perfectly willing to admit that here, if nowhere else, woman is a superior being. Superior in skill, superior in making something out of nothing, superior in patience, superior in consummate long-suffering.

All in all, the mothers of this generation can do no greater work for those who are to follow in their footsteps than to teach their sons to use the

needle to the best advantage. I am aware that this may be considered a dangerous and perhaps somewhat heretical doctrine by some of my gentlemen friends. The possibilities are indeed great that this is so. But I am willing to take the chances of ever being obliged to do the mending for the entire household if I can impress upon the ladies the fact that their sons will one day rise up and call them blessed if they teach them how to sew, if only tolerably well. EDGAR L. VINCENT.

CROCHET FAN-LACE

Abbreviations.—St, stitch; d c, double crochet; s c, single crochet; ch, chain. This lace is very pretty for pillow-cases, underwear, etc. Make a chain of 15 stitches.

First row—Miss 3 ch, make 3 d c in 4 st of chain, ch 2, miss 2 st, 3 d c in next st, ch 2, miss 2 st, 3 d c in next st, 5 ch, miss 5 st, 1 s c in last st.

Second row—2 ch, 10 d c in 5 ch, 2 ch, 3 d c in 2 ch, 2 ch, 3 d c in 2 ch, 2 ch, 3 d c in 3 ch.

Third row—3 ch, 3 d c in 2 ch, 2 ch, 3 d c in 2 ch, 2 ch, 3 d c in 2 ch, 1 d c on d c, \* 2 ch, 1 d c on next d c; repeat from \* eight times.

Fourth row—2 ch, \* 2 d c in 2 ch; repeat from \* eight times; 2 ch, 3 d c in 2 ch, 2 ch, 3 d c in 2 ch, 2 ch, 3 d c in 3 ch.

Fifth row—3 ch, 3 d c in 2 ch, 2 ch, 3 d c in 2 ch, 2 ch, 3 d c in 2 ch, \* 2 ch, 1 d c between the first and second 2 d c; repeat from \* eight times.

Sixth row—2 ch, \* 3 d c in 2 ch; repeat from \* eight times; 2 ch, 3 d c in 2 ch, 2 ch, 3 d c in 2 ch, 2 ch, 3 d c in 3 ch.

Seventh row—3 ch, 3 d c in 2 ch, 2 ch, 3 d c in 2 ch, 2 ch, 3 d c in 2 ch, \* 5 ch,

1 s c between the first and second 3 d c; repeat from \* eight times.

Eighth row—\* 5 ch, 1 s c in 5 ch; repeat from \* eight times; 2 ch, 3 d c in 2 ch, 2 ch, 3 d c in 2 ch, 2 ch, 3 d c in 3 ch.

Repeat from the first row for the length required. Then joining the scallops together, the first row fasten with 1 s c in second s c, third row fasten with 1 s c in middle of 5 ch, fifth row fasten with s c on s c, seventh row fasten with s c in middle of 5 ch. A. L. A. B.

SUNBONNETS

From time immemorial the sunbonnet has held its place in the minds of women as the regulation head-gear, and from the point of usefulness and general popularity is not likely to be superannuated. As a proof against the damaging effects of the elements to the complexion our feminine ancestors relied more wholly upon the faithful wearing of it and as being more satisfactory than all the cosmetics of the present day; and the lassie who wore her bonnet, and kept it tied, usually possessed a skin of enviable fairness.

Purpose has made it soi-disant, which fashion has done little to rejuvenate. A woman can wear a sunbonnet when she can afford nothing else as a head-covering, as they range all the way from the homely, straight-slatted kind of our grandmothers' time, the machine-stitched, full-crowned gingham or tea-straw to the fancy, lace-embellished affairs of to-day; for it is really possible to make them charming and expensive enough for the most fastidious tastes and still retain their individuality.

There are many materials mentionable to make effective bonnets, such as chambrays, percales, ginghams and dimities; but for simple elegance white India linen daintily trimmed with Valen-

ciennes insertion and edgings is unsurpassable. A much-admired bonnet this season is made of red percale combined with yellow Tuscan straw braid and lace insertion. The foundation is cut from heavy brown paper or light buckram in such a shape as to flare slightly over the face; both sides of the paper are plainly covered with red percale, on which is stitched rows of the braid divided by a row of insertion one and one half inches wide. The front edge is finished by a full puffing of percale placed between two rows of the braid. The inner side is lined with a wide pattern of scalloped lace sewed flatly to the red lining. A full crown is put on in such a way as to form a double ruffle across the top of the head, and a straight frill, also trimmed with the insertion, is sewed around the bottom. Wide bows and ties of percale finish the bonnet, which when complete is as dressy as a hat. Soaking the braid in a weak solution of salt and stitching before entirely dry renders it more pliable. The fancy lace braids make particularly handsome bonnets. HATTIE P. HAMER.

SUNDAY REST

If Sunday rest were not a sacred duty imposed by our All-wise Father it would still be a physical duty. Yet how few people strictly observe the commandment to rest one day in seven? I often think if we would return to the old-time Puritan Sabbath customs it would be a boon to tired housekeepers at least. In those days Saturday was made a day of preparation. Enough was cooked on that day to last until Monday. The house was set in order, the Sunday clothing laid out, and the children given their bath.

Not alone did the mother prepare in this way for the Sabbath, but the father also planned to finish his work at a regular hour on Saturday; so that when the sun went down on that day the Sabbath quiet commenced, and the evening was spent in religious reading.

With the utmost effort to prepare for the Sabbath there are always many duties, especially in the farm home, that must be attended to. Outdoors there is the milking, feeding and care of stock, and within the necessary meals to be prepared, the dishes to be washed, the milk to take care of, etc.; but in too many homes the work is increased by making Sunday a day of feasting and entertaining company, until at night the housewife is ready to declare that Sunday is the hardest day of the week for her. I do not say Sunday should be a fast-day; but I do believe it would be much better for all concerned if we would eat only such food as can be mainly prepared on Saturday and would require but little work to put it on the Sunday table.

I would make it a fixed rule to never make visits on Sunday, then people would soon cease to visit you; if they did come, make no extra work in setting out the dinner, and they will soon learn that you do not desire Sunday visitors, and you will find yourself rested and ready to take up the work of another week on Monday morning.

I would not return so far to the Puritan customs as to deny the children every toy on Sunday, and forbid all playing; but I think it is a good practice to have some special toys and games to be used only on Sunday. Whenever it is pleasant, a walk with papa and mama is enjoyed by both children and parents, and looked forward to as one of the pleasures that Sunday brings. As the children grow older let them get the Sunday tea, with father and mother as their guests. They will enjoy the work, it will be a rest for mother, and many a little surprise will be planned and prepared for on Saturday.

There is a difference of opinion about the age when children should go to church, some thinking that they will get a distaste for church if obliged to go before they can be interested in the service. I do not believe this. As far as my observation goes, the force of

habit holds good in this respect as well as in others. It will not hurt a healthy child, even when quite young, to sit still for that length of time.

Very early they can learn to reverence the house of God, and a habit of church-going firmly established in early youth will be apt to hold through life. Make Sunday just as restful, bright and happy a day as possible for the whole family—a day the children will remember with pleasure all their lives, and in the homes they afterward build for themselves they will seek to perpetuate its pleasant customs and observances. MAIDA McL.

THE LANGUAGE WHICH BABY'S PRESENCE PRODUCES

"It's all nonsense to protest so vigorously against indulging in baby talk," said the experienced member at the mothers' club. "There is a certain language which an infant's presence produces, and all the pros and cons of theorists cannot stop it."

You have all heard it—that is, if you have ever seen a baby surrounded by admiring adults. They may be wise-acres and savants when this bit of infantile loveliness is not in their midst, may discuss well and learnedly on profound topics, become wonderfully excited over the argument whether Mars is inhabited or not, yet away goes high-flown scientific phrases when the little perambulator or the nurse with a child in her arms appears in sight. If this particular baby happens to be the first one in many years in a family of adults, then is the language even more universally adopted than in those circles where a baby more or less is no unusual thing.

It goes something like this: "Was oo auntie's 'ittle petsie boy?" "Mama's bessy baby?" and similar expressions too familiar to need repetition. And what does the object of this attention do? As a rule "it" sits up and looks wisely out of the dear innocent eyes with an air of worldly wisdom sadly at variance with the gushing of those about it. Some little creatures look so profound and solemn that it seems an insult to their intelligence to indulge in the Volapuk of babydom that to the uninitiated is about as intelligible as ancient Greek to a modern school-boy.

Yet unless the baby is a product of Boston culture it is certain to be addressed in this language, that by common consent has been called "baby talk." No one can tell its origin, unless, indeed, some fond mother in the years that are gone, feeling that the stilted syllables of her own tongue were too much for the little soul to grasp, invented the cooing, caressing, broken tones that women of all ages have learned to employ when speaking to an infant.

Argue as we may concerning the probable harm to the little one who is just learning to talk, and the "senselessness of the practice," it is safe to prophesy that just so long as there are babies in the world the language known as "baby talk" will never become obsolete. P. W. H.

MOTHER AND CHILD

A man and a woman, old acquaintances who had not met for a long time, were talking of what had occurred during that time. The man said, "I have married again, and we have one child; but my wife went to her parents because I was out of employment and could not provide for her. I have a school now, and am going for her tomorrow. If she will not come with me I shall take the child."

The woman replied, "You have no right to take the child from its mother."

"Oh, but the child's future must be considered, and she is not fit to bring it up."

She turned upon him with a look that was like lightning, and the words fairly leaped from her mouth, "What right had you, sir, to make a woman a mother who is not fit to bring up her own child?" He looked as if he had been struck by lightning. He hemmed and hawed a little, but could find no words with which to reply, and after a few moments got up and left.—From "Clothed with the Sun."





## A FAIR FIGHT

By Mattie Dyer Britts

## CHAPTER VII.

THE new store was ready for business in a week more, and opened its doors with everything bright and shining, plenty of fresh paint and brilliant window-glass, and most attractive displays of brand-new goods.

Ladies have always been proverbial for their love of something new under the sun, and they flocked into Begole's in groups the first day of the opening.

That opening in itself was a revelation to Mr. Van Gillen. He had always been contented to bring on each season's stock of goods and sell them as they were wanted. To have his store filled with a lot of flowers, a band engaged to play in the evening, and the town flooded with pretty circulars announcing all this, was out of his ideas—he had never done anything of the kind. To be sure, he well knew that those things were done every year, but he had always said, with evident pride, "All claptrap, sir! No need in the world of such flummery! Van Gillen's has always been able to sell all the goods brought on without any such cheap advertising. I sha'n't do it!"

But now, as Mr. Van Gillen sat at his desk, being much too proud to stand at the door and watch the rival across the street, and saw the crowds of ladies, and gentlemen, too, going in at Begole's, he began to wish he had done something of the sort. "Won't half of 'em buy!" he growled. "They'll stand 'round and handle the goods and make remarks and go away. I know 'em! Let them go!"

But it galled him terribly to see those who had always been his own customers flocking to the new store, and made him dislike young Begole even more bitterly.

"Hang it! If I had taken the young monkey in with me it would all have been here!" he grumbled, sitting at his desk. "Of course, the smart jackanapes would have had his own way, but I would have reaped the pocket harvest—if there is any. Confound it all! I suppose he will pitch right in now and have a mark-down sale, to catch all the silly women. If he does, I'll—well, I won't say just yet what I will do. But he shall be taught that fire-crackers can't be heard where old guns are shooting. I'd like to choke him, the cheeky scallawag!"

At dinner the day of the opening Mr. Van Gillen remarked to his family, "I don't suppose either of you will want to go to that fool's opening to-night. But if you do, I can tell you I won't have it! My folks shall keep away from him!"

"I haven't any idea of going there, papa," answered Virgie, very calmly.

"Well, I confess I'd rather like to see the new things," said Miss Maggie. "Of course, if you make a point of it, Jason, I shall stay away. But I can't see why the world isn't wide enough for everybody, and why two merchants in the same town couldn't help each other, instead of running each other down."

"Mr. Begole has never run father down, Aunt Maggie!" spoke up Virgie, with some warmth.

Her father cast a glance at her. "Highty-tighty, young miss! You take sides with him, do you?"

"No, sir, I don't! But you know, papa, that the evening he called on you he talked and acted like a gentleman, and I'm sorry you did not receive him better. I think it would make custom for you if we did all go to Mr. Begole's opening and try to be friendly with him. But as you do not wish us to go, why, I am entirely content to stay away. Only I think you are wrong, decidedly."

Mr. Van Gillen was actually too angry to make her any reply. He stared at her for an instant, then without one word put on his hat and went out.

"Your pa's good and mad now, child!" said Aunt Maggie.

"Well, annty, I'm sorry. But I had to speak the truth if I spoke at all."

"I'm most scared to think we said anything, though, Virgie. And I'm in a pickle, too, for I told Mrs. Hagan that I would go 'round to the opening with her. I never thought of Jason objecting."

"Go if you like, Annt Maggie. Father has no right to dictate to you as he has to me."

"No, I won't go. I'll send her some excuse. But I do wish Jason wouldn't act so. That young fellow is a nice, likely young man, and I'd be glad to be good friends with him. I wish he would come to our church, then Jason couldn't say anything if we met him occasionally."

Mr. Van Gillen was walking with hasty stride down to his store, his mind in an angry tumult.

"My daughter never spoke to me like that before," he thought, "and I can see Maggie's as mad as hops! I have him to thank for rebellion in my own household, as well as injury to business! If I don't get even with him I'd like to know why! There isn't much I wouldn't do to beat him now!"

It was not an enviable frame of mind to be in. Nor was it helped any when, the next morning, Mr. Van Gillen heard that the new store had sold a remarkable quantity of goods that very first day. To be sure, his own sales had been as good as usual; but he knew when it came to a contest in prices the younger man would have the advantage, and the thought was not a pleasing one.

Miss Maggie had no opportunity through the week to find out what church Mr. Begole attended, if, indeed, he went to any at all. But the next Sunday, as she sat with Virgie in their own pew, who should walk in but Mr. Begole, and take a seat only a short distance from them? Virgie kept perfectly still, and did not turn her head when Annt Maggie whispered to her that he was there; but somehow a very pretty pink spot came into Virgie's soft cheek, and stayed there all through the service.

Somehow, in going out, too, they were obliged to pass very close to Mr. Begole, and as he bowed to her Virgie could not do less than speak to him and introduce Annt Maggie. It was a part of good Annt Maggie's religion to be cordial to strangers in church, so she would not break her rule, Jason or no Jason. She shook hands with Mr. Begole, and told him she was glad to see him there.



"IT WON'T MAKE YOU TROUBLE, THIS LITTLE DRIVE, WILL IT?"

and hoped he was going to make that church his Sabbath home.

"I have hardly made a choice yet," was his smiling reply; "but I like your pastor very much, and I may conclude to remain with him. You attend regularly?"

"Oh, yes; we never miss," was Annt Maggie's answer.

A single glance at Virgie, unseen by anybody else, told her plainly that Mr. Begole would not "miss" often, either, if she was to be there, too, though he said no more then.

A day or two later in the week there was posted up in the window of the new store this notice: "Special Sale Saturday. Great Bargains in Gloves and Muslins. A Summer Picnic for Everybody."

"Humph! 'Summer picnic! 'Gloves and muslins!' " grunted the older merchant. "I'd like to give him a picnic! Can't I do it? I will if it costs every dollar of profit for the season! Look out, Mr. Begole; two can play at some games as well as one!"

Then and there was born in the bosom of Mr. Van Gillen a thought of which in his after-life he was always heartily ashamed. He did a very mean trick—sold his self-respect to his temper to gratify a needless spite; but he was too nettled to admit the thing in its right light at present.

As he sat at his desk all the morning he was thinking and planning and glancing around the store for a proper tool. When people desire to plan mischief Satan always stands ready to aid them. Mr. Van Gillen found his tool in the person of Harry Ford, the youngest of his clerks. Harry wasn't a

boy of the best principles in the world, and not a favorite with his employer. That was the very reason Mr. Van Gillen selected him just now. He had caught Harry in scrapes several times, and that gave him a sort of hold on the fellow. Just before he went to dinner Mr. Van Gillen called Harry into the office, saying he wished to speak to him.

"What's up?" thought the youth, as he obeyed the summons. "Going to get my walking-papers? Wonder if he knows where I was last night? If he does, that's it."

But inside the office he asked, with his usual cool audacity, "Did you wish to see me, Mr. Gillen?"

"Yes, I did. Sit down here a moment." The merchant pushed a stool toward the clerk, an act surprising in itself. Harry was ready for almost anything, but certainly not for the first question put to him.

"Do you know any of Begole's clerks?"

"Yes, sir, I do. George Lewis is a chum of mine."

"Humph! Pretty clever sort of chap?"

"I think he is, sir."

"Bright?"

"Well, I've seen brighter boys. But pretty good company."

"Exactly. Got a wheel, haven't you, Harry?"

"Yes, sir, I have," answered Harry, wondering what in the world all this meant.

"Well—" Mr. Van Gillen hesitated now, for he was really ashamed to mention what he had to say. "I suppose you have seen the bill stuck up in that fellow's window?"

"His Saturday sale? Yes, sir."

"Now, Harry, I have a bit of work for you

"Very well, Mr. Van Gillen. I'll do my best."

"See that you do. If a word leaks out I shall know where it came from, and then—well, Harry, you know I could make things rather warm for you if I chose to do it."

"Yes, sir."

But as Harry walked out of the office his air of humility was changed for one of glee, not unmixed with triumph.

"But you won't make it warm for me, old man, for I could turn the tables on you! Ha! ha!"

That evening, as Mr. Van Gillen was out in his carriage with his daughter and sister, as usual, they passed Harry Ford and another fellow riding down the smooth road on their bicycles, and Mr. Van Gillen smiled, for his little scheme promised to work well.

All day Friday the white curtains were up in the windows of Begole's store, and the public knew that the tempting articles for next day's sale were in process of arrangement. No curtains were up at Van Gillen's, but when closing-time came Friday evening Mr. Van Gillen called up the clerks in those departments, and said, "See here, gentlemen and ladies. I have taken a fancy to have a sale in my place to-morrow, and see if I can't get ahead of that young spark over the street. I want you to come back to-night and mark down the goods in plain figures and dress the windows to-night. I'll see that you don't lose by it, whether I do or not. And I'll say just here that I don't care a picayune whether I lose or make—I am bound to beat that chap, and that's all! I'll be here myself—we'll do the work if it takes all night—and I don't want a word said outside, only that we are thinking of a sale."

Of course, the clerks agreed to come back. They worked very late, with curtains closely drawn, and by half-past twelve all that could be done that night was completed. Prices were simply nothing—but they were a half less than those of the other store.

"I'd like to know how the old man found out so much about Begole's business?" said one of the older clerks, as they were about to quit.

"So would I," remarked another. "He's just gone crazy; but it isn't our fight—if he wants to give goods away, all we have to do is to hand 'em out. But I say, fellows, it gets interesting, don't it?"

Next morning it was certainly interesting, and a trifle amusing, to see the surprise of people when they saw Van Gillen's windows filled with snowy muslins, dainty cambrics and rows on rows of kid and silk gloves, every yard and pair having upon it a ticket bearing its price—and in the case of some of the really good gloves that price was not over twenty-five cents.

There was evident surprise in the store across the street. They could see the clerks come to the door and stare over at their display, and talk among themselves, while the crowd, gazing in at both stores, mostly came over to Van Gillen's to trade.

"Did you ever hear anything like it?" the ladies would say. "Why, it is simply ridiculous to sell goods like this! But of course we will buy where we can get the cheapest."

Mr. Van Gillen went about with a grin smile all day, and Mr. Begole, when they saw him, appeared just as usual, calm and pleasant as a May morning. When night came Van Gillen's house had taken in a good deal of money—but the proprietor knew that it did not cover the first cost of the goods sold. He had won the crowd, however, and that was his object.

Miss Maggie and Virgie heard of it, and readily guessed that it was done to beat Mr. Begole. They said very little, though both of them were mortified over the matter, and to what they did venture Mr. Van Gillen only answered, "What's the matter with you? Hasn't a man got a right to sell his own goods at his own prices?"

"Yes, papa, if he does not do it to—to—"

"Well, out with it, miss!"

"I don't want to make you angry, papa; you get out of humor so easily of late."

"Sance-box! I want to hear what you had to say!"

"Then, papa, I was going to say, if he does not do it to get the best of some other man."

"Humph! Well, you tend to your own business and I'll tend to mine! When I want you to help me run the dry-goods store I'll let you know!"

Mr. Van Gillen went out with a slam of the door. Miss Maggie looked up with a worried manner. "What in the world has come over Jason Van Gillen?" she exclaimed. "He acts as if he was going out of his mind."

"I hope he is only coming into it, Aunt Mag," said Virgie, sighing. She understood her father better than he imagined she did just now, but she had no idea how far he had actually gone in the wrong direction.

She had not seen Herbert alone since the day she met him in Silverdell, but she saw him at church almost every Sunday, and sometimes met him at the houses of friends, for he was being very well received in Ashland society. He had always a kind look and word for her, but he did not presume in the least, and she liked him better for it.

"It's a tedious time," she said to herself; "but he will win his way with papa in the end. I can stand it. But I won't go away just now—I might be needed here."

She had received a letter from Mrs. Pearson, inviting her to come to Atchison for a

to do. It is all fair and square in business, and not a bit more than he would do, though it may not seem so at first thought."

"I reckon I'll try to do anything you ask me to, Mr. Van Gillen."

"I'll make it worth your while," said Mr. Van Gillen, with an insinuating tone. "I want to know what class of goods he is going to put out, and his prices; then I may take a notion to have a sale of my own."

"Oh! I understand now, sir!" was Harry's reply, though he kept back the grin which he did not dare show. "You want me to find out for you?"

"That's what I want, exactly. You are a sharp boy to catch me up so quickly. Here is the case—can you keep a still tongue if, as I said, it is made worth your while?"

"Try me and see, Mr. Van Gillen."

"I will. I want you to get hold of that chum of yours over there and get out of him all he knows about the sale. I want it done every time he has one, as long before the date as possible. Can you do it and not let your friend see what you are after?"

"I rather think I can, sir."

"Very well. I would suggest a wheel-ride with him, or something like it, but I leave that to you. See him, and get all the details you can out of him, bring me your report, and keep a silent tongue to everybody. You understand?"

"Perfectly, sir."

"All right. Every time you bring me word of a sale twenty-four hours before the news is out to the public it is two dollars and a half in your pocket; that's all."



month, before the cold weather began, and she intended to go. Something, however, which she could not explain, made her unwilling to go at present, and so she wrote to her friend that she would come about the middle of October.

Wednesday of the week after the first special sale, before the hills were up in the window, Mr. Van Gillen saw Harry Ford waiting for him as he came back from his dinner.

"What is it?" was his brief question. "Laces and ribbons this week, sir. At half prices, all kinds."

"So? All right; thank you."

No one had noticed the few words passing, but when Mr. Van Gillen ordered his force to mark down ribbons and laces of all description many looks were exchanged.

"He's got some way of finding out what the other man does," said more than one clerk. "I'd give a penny to know how he does it."

Mr. Begole would have given more than a penny to learn how Mr. Van Gillen knew his plans, when, on Saturday morning, the windows of both stores were almost exact counterparts of each other, except that the prices in Van Gillen's were less than any man could afford to sell at. The third week, though Begole was careful not to let a soul outside his own store know what the sale was to be, it was just the same—both windows were draped from top to bottom with hosiery and underwear at prices which would have made the manufacturers stare.

"Now I know there is a traitor in my camp," was Herbert's reflection. "I'll watch and find out who he is."

The competition between the two began to be the town talk, and people looked with anxiety and amusement to see what each Saturday would reveal. But Begole would not talk on the subject—that is, to outsiders. It was seldom the men met, each appearing determined to keep his own side of the way; but one morning they came face to face as both were coming down to begin the day's business. It was on Monday morning after the hosiery sale, and Mr. Van Gillen had been delighted to see that the largest crowd was at his own place. He could not help saying, as they gave a good-morning, "Ah, Mr. Begole, how much did you make last Saturday? Rather think I had the best of you, didn't I? Wish you was my partner, don't you?"

The younger man looked the elder one straight in the eye, and answered, "No, sir, not now. If the course you are pursuing is your idea of manly honor I am glad I am not associated with you. It is not my idea. Good-morning, sir!"

He bowed with dignity, and hastily crossed the street. Van Gillen laughed, and muttered, "It hurts, I see! All right; I'm ready to go as far as he will. I don't think he'll get rich—not in a hurry. Shouldn't wonder if I run him out of town before the year ends. Ha! ha!"

#### CHAPTER VIII.

For four or five Saturdays things went on the same. Mr. Begole and Mr. Van Gillen had sales of the same goods, but Mr. Van Gillen's prices were always the lowest. Some people thought it fine to secure such bargains, but the more sensible folks of the town began to shake their heads and say, "Can't see how it is done. They cannot be in collusion, and Van Gillen would not do any underhanded trick. It is a mystery. But Van Gillen is acting very foolishly, for no man can keep up long and sell at such prices. The new man seems a very clever fellow; guess I'll have my folks buy of him."

So it soon came out that even at the cheap prices Mr. Van Gillen had not the crowd that the new store had on Saturdays and special-bargain days. Through the latter part of August and the first of September Mr. Begole offered no special days; neither, of course, did Mr. Van Gillen.

"Reckon they won't make any more runs until they bring on the late fall goods," was Harry Ford's report to his chief. "But I'll keep an eye open, and if anything goes on I'll let you know, sir."

"Very well, see that you do," said the merchant, shortly. Harry had begun to take on an airy manner which was not pleasing. The other employees in the house were very much provoked at him.

"That young man needs a calling down," said one of them one evening. "You would think he owned the whole store, to hear him give orders. I won't stand any of it myself."

"I'm with you there, Frank!" said another. "But you never mind! He'll let Old Van Gillen hear him some day, and then won't he get fired too quick? Oh, no, I guess not!"

"Old Van Gillen pets him," put in a girl at the ribbon-counter. "The rest of us aren't in it when Ford's around. I'll quit myself before long if he don't, and go over to the new store."

Virgie had come into the store, and standing a little hidden from the group by a glass case, she heard every word. She did not really believe Miss Cox was in earnest in saying she would quit and go to Begole's, but it worried her.

"Oh, my, I hope papa's clerks won't any of them do that!" she thought. "He would hate poor Mr. Begole worse than ever, and I don't want that to happen. I wonder where he is?"

I have not seen him for several days. He was not to church Sunday, and so many are sick this hot weather; I am real uneasy about him."

It was odd how the man who so short a time ago had been an utter stranger to Virgie should now be the object of so many anxious thoughts, wasn't it?

It was true that the hot season had proved very trying, and the sick-list was largely on the increase. Mr. Van Gillen had urged Maggie and Virgie to go out to Denver and have a cool rest; but Virgie would not be induced to leave home just now, and Miss Maggie would not go without her. That day Mr. Van Gillen had come home to dinner and told them he wished they would go over and see Joanna, for he had heard that one of her little children was quite sick.

"I will go over this afternoon," said Virgie, promptly. "I have been intending to go for a week."

"All right. Have Joe drive you out," said Mr. Van Gillen. "It is too warm to walk."

But when she was dressed to go out Virgie did not call Joe. Miss Maggie was taking her afternoon nap up in her own cool chamber, so she could not object to the girl's walking, as she surely would have done.

"It isn't so hot this afternoon," said Virgie, as she stepped into the street, "and I had rather walk than drive. Of course, I know I shall not meet anybody this time, but I will walk, anyhow."

She did not meet a single soul after she left the street and took the lane leading into Silverdell. But when she came in sight of Joanna's cottage she saw a buggy hitched at the gate.

"Probably the doctor," she thought. "I wonder if little Fred is much sick?"

She hastened her steps, and soon stood upon the tiny front porch, when, to her great surprise, Joanna's voice was heard just within. Some one stepped out as she was about to enter, and the some one was Herbert Begole.

He met her with outstretched hand. She gave him her own, vexed with herself for the hot color which she felt rush into her face.

"I did not expect to meet you here in business hours, Mr. Begole," said she.

"I don't leave often, Miss Van Gillen, but Klein told me his child was sick, and I stole time enough to run out for a minute. Surely you have not walked out this warm day?"

"Yes, I walked, though papa told me to take the carriage. I didn't mind it at all."

"Please make your call short and let me take you back in my buggy," said he, with a pleading tone and look from his dark eyes which Virgie did not know how to resist.

Why should she not have a few happy minutes with the man to whom she owed so much?

"Very well, since you are so kind," she said. "I did not intend to stay more than ten minutes, anyway."

"Better come in again, Mr. Begole," said Joanna, from the door.

"No; I will wait for Miss Van Gillen in the buggy," he answered; and as Virgie went in he untied the horse and took his seat in the buggy.

Virgie found that little Fred had been very sick, but was now improving.

"We would have come before if we had known it," said she, kindly. "Aunt Maggie will drive out in the morning and bring you some fruit and things for Fred."

"Don't take no trouble for us, Miss Virgie dear. I don't reckon we'll need any fruit for a day or two. Look here what Mr. Begole brought out." She lifted the paper from a basket glowing with rosy and golden apples, juicy oranges and bananas. "He's the best man I ever did know, Miss Virgie," she went on. "You can't guess the good he's done for Klein, keeping him out of the saloon; and when Fred got sick he told Klein to get the best doctor in town, and he'd settle the bill. I tell you there ain't many like him, and that's the truth!"

"He seems very nice and good, Joanna."

"Well, honey, he is what he seems, and you can't say that for everybody. Yes, Freddy, mammy will get you a nice drink of ice-water that the kind man sent Freddy. Here, raise your head, and look; here's Miss Virgie come to see the little boy."

Virgie did not make a long call; she was too conscious of who waited for her. She went out and took the seat to which Mr. Begole assisted her, with an anxious glance around, while Joanna watched them from the door with a satisfied smile.

"Now, Miss Virgie," said the young man, "I don't want to get you into the least trouble, as you well know; but if it will not do so, this is a great and unexpected pleasure to me."

"It is to me, too," answered Virgie, frankly. "I have been wishing to see you, and was afraid you might have been sick this terrible weather."

"No; I was never better," said he, with a smile into her eyes. "But I feel highly honored to know that you have thought of me at all, and cared for my safety."

"I ought to, Mr. Begole. I remember when you cared for mine."

"You don't mean that I don't care for it now?"

"You know I don't."

"Yes, I do know it. We have no time to waste in silly speeches, have we, so let's be honest with each other. I care more for your

welfare than you guess, and I've made out to see you every day, even if only passing in and out of your father's store."

"Mr. Begole, that is one reason I wanted to see you. I am so sorry papa is—doing as he is just now."

Begole laughed lightly.

"Please don't worry your head over trifles. He does not disturb me, not in the least. I am only sorry he dislikes me so."

"But you know it is not right to take—"

"There, Miss Virgie, don't let's talk about it at all. I am waiting; my turn will come one of these days, and I will make a friend of your father. I can wait. But it would be easier if I could see you oftener. I suppose that cannot be at present?"

Virgie shook her head.

"No, it cannot."

"Do you wish it could?"

"Don't ask me that."

"It won't make you trouble, this little drive, will it?"

"No, I think not. Papa will not be at home, and Aunt Maggie won't say anything if she sees us. Mr. Begole, we will soon be there. Once I made you a promise, will you make me one to-day?"

"I believe I am safe in saying that I will, with pleasure."

"It is only this: Sometimes men have very serious quarrels over business, and papa can be very aggravating when he takes a notion. Will you promise me that you will not be drawn into a quarrel with him?"

"Why, my dear child, it is not even necessary to ask me that! I do not think I would forget what was due to an older man in any case, and in this one—well, you see, I have too much at stake!"

She looked up at him with a look which seemed to ask what he meant. He let his free hand fall upon hers as it lay in her lap, and said, very earnestly, "Now, take this comfort to your sweet soul, your father shall be to me as my own, if he were living, and the respect I gave to the one I shall give to the other, in the hope of better things in the future. Do not fear; he may think me his enemy now, but he shall come to think of me as a son—as I mean to be one of these days."

Virgie did not have a word to say in answer to that speech, and they were at her own door by this time. She let him help her from the buggy, hid him good-afternoon, and thanked him for his kindness, for the benefit of the neighbors, if anybody chanced to see them, and went into the house feeling much happier than she had for a month. But none of the neighbors were out at that hour, and Aunt Maggie was still asleep in her room, so nobody was the wiser for that little ride.

[TO BE CONTINUED]

## A CLODHOPPER

By W. Bert Foster

"I don't see what that great hulk of a boy is good for!" exclaimed Farmer Hughes, in much vexation, as he sat down to supper in the pleasant kitchen.

"What's the matter with Cale now, father?" queried his wife, mildly.

"Matter enough!" The farmer had just returned from the near-by market town and was tired both in body and temper. "I set him to mowing 'round the walls of that east medder when I went away, so't we could put the machine in there to-morrow and get the grass down. What'd he do when he got around the aidge but start in with his scythe and chop down nigh a quarter of that grass."

"A quarter of the east medder!" exclaimed Mrs. Hughes, in wonder.

"That's just what he done, Maria. Did ye ever hear of such a senseless trick in your horn days h'fore?"

That phase of the matter did not seem to appeal to good Mrs. Hughes. "Why," she cried, "I don't see how he managed to do so much in one day! He came in with a dreadful red face at noon, I remember, an' looked as though he'd been workin' extry hard. But I didn't s'pect what he was doin'. 'Twas enough to kill him, Silas!"

"Humph!" The farmer looked slightly disgusted. "You couldn't hurt him with work. He's strong as a bull, an' no more sense to him. Why," he grew excited at the thought, "if I should tell him to go out yander and move the eorn-crih he'd go ketch hold of one corner an' try ter lift it. He ain't got no more judgment—"

"Well," interposed Mrs. Hughes, "Cale does a power of work—as much as any man you ever had, father, and for less money."

"I dunno hut it'd be cheaper to hire some brains along with the muscle," responded the thrifty farmer. "Ye gotter stan' right over Cale to get anythin' done right."

"Now don't you scold the boy to-night, father," said Mrs. Hughes. "If you do you'll say something you'll be sorry for afterward."

"That's just it," grumbled the farmer, who knew his own disposition pretty well. "I sha'n't scold him at all if I don't do it while I've a mind for it."

His wife laughed comfortably. "I know you, Silas. You'll think better of it to-morrow. You won't find another boy as good as Cale Burroughs in a week o' Sundays."

Farmer Hughes went to bed pacified, and

his "hired help" was saved a scolding, as he had been many times before by Mrs. Hughes' good offices. It was very true, however, that Cale was a most exasperating youth and often deserved the rebukes he received.

There was one part of his duties, however, in which Cale Burroughs could be trusted to the limit. Mr. Hughes' horses were better cared for than any other farmer's within a radius of twenty miles. Cale understood the creatures, he never neglected them in the smallest way, and his employer, who loved horses himself, would have been sorry to part with him for that reason, if for no other.

"Cale's got a way with horses, mother," he often said to his wife, "that can't be beat."

In fact, it was quite necessary to "have a way with horses" about Farmer Hughes' barn. He purchased his horses with a view to their strength and ruggedness rather than their docility, and in one or two cases anybody less courageous or less fond of the animals would have got along badly with them.

This could be said of one in particular—a great high-headed, coal-black horse, with a nose as long as a barrel, and lean, muscular limbs. He was a tireless brute in harness, although he was old now and his teeth were not of the best; but he was pretty sound of wind and limb, and at times showed all the fire and spirit of more youthful years.

The farmer had never had a helper before who could safely be trusted with Black Bob; but Cale Burroughs' muscles and his cool head could always control him. The horse was seldom used in anything but a heavy farm-wagon and for heavy work.

The Hughes were thrifty people, and, owing a large and comfortable farm-house, they were in the habit of accommodating summer visitors. By the first of July there was a merry party of city people at hand, and Mrs. Hughes and her one serving-maid had their hands full indoors. The visitors made no slight addition to the farmer's work as well. There were driving-parties, and boating-parties on the river, and picnics galore; swings and hammocks to be hung; grass to be mowed in the lot beside the house for the accommodation of croquet-sets and tennis-court. Cale found himself at the beck and call of all these visiting young people, and in some ways did not like it.

There were those among the boarders who seemed to consider that Farmer Hughes' "hired help" had been brought into the world for their sole comfort.

Despite the thoughtless treatment the summer boarders accorded him Cale was careful of their comfort. The horses were always harnessed on time, and the carriages washed each morning; and this last was no small task, for Riverton roads were dusty. Three of the farmer's horses were usually at the disposal of his guests; but although the great black was a good traveler and looked well in carriage-harness, he was never used for such light work. He was not to be trusted, especially with strangers, and neither the farmer nor Cale had time to often drive the pleasure parties about.

It was late in August when Ralph Armstrong came down to Riverton for his vacation. He had cousins at the Hughes', and he engaged board there himself, as a matter of course. The plain country fare and simple comforts of the farmer's home did not entirely satisfy him, however.

"This is the slowest place I ever was in," he told his Cousin Maud, in disgust. "I hope auntie and you won't come here next year—not if you expect me to escort you."

"That will be a fatal objection to the place," she returned, regally; but Ralph had much too good an opinion of himself to see the sarcasm in her declaration.

Ralph became one of poor Cale's principal annoyances, and Cale, whose temper smoldered intensely if it did not easily flash into flame, was strongly tempted to thrash him soundly. Ralph's supercilious airs and speech were terribly galling.

Ralph had his eye on Black Bob, and knowing any request for the animal would be refused, he determined to use him without asking. A lot of the girls went to drive one afternoon behind the sorrels, and before it was time for their return Ralph decided to drive down the road in the light wagon to meet them.

"You needn't mind about harnessing for me," he said to Cale, who was busy in the kitchen-garden behind the house. "You're engaged here; I can harness."

Cale thought this wonderfully accommodating on Ralph's part; he was very busy, and Nellie, the little roan mare that was always used with the single carriage, was the gentlest creature imaginable. Anybody could harness her. So Ralph went off to the barn; but as Cale did not bear the sound of wheels in some little time he feared something had delayed the city boy and he stepped around to the barn-yard to assure himself that all was right. To his amazement Ralph had harnessed the big black into the light vehicle and was about to climb to the seat.

"What are you doing with that horse?" demanded Cale, sternly. "You know Mr. Hughes does not allow him used in such a rig!"

"Well, the old man isn't here," said Ralph, calmly, "and I'd like to know what you've got to say about it."

"I haven't anything to say," returned Cale.



"I thought not."  
 "But I shall do something."  
 "Ah, will you?"  
 "Yes, sir. You must either unharness that horse at once and put him back in the stall or I shall have to."  
 "I guess not!"  
 "And I guess yes!" exclaimed Cale, losing his temper.

He sprang forward to seize the reins, but Ralph leaped into the wagon. The big black, excited by this demonstration, started off with a plunge, and whirled out of the yard in a cloud of dust. But Cale had caught the tail-board of the wagon and in a moment had clambered in. Ralph was too much engaged with the reins to pay any attention to Cale; but when the latter reached over his shoulder and seized them the city boy turned a white, angry face up to him.

"It's all your fault!" he spluttered. "You scared him! Now he's running away!"

It was a fact. Black Bob had not been out of his stall for three days, and it hadn't taken much to start him off. He'd got his head at the first jump and was now tearing down the dusty, narrow road at a pace which made the light vehicle sway perilously behind him. Cale did not utter a syllable. He climbed carefully over the seat-back, pushing the terrified Ralph to one side, wound the lines around his wrists and braced his feet. Then he began to pull steadily back upon the maddened creature's bit; but it was like trying to retard the onward rush of a locomotive. Black Bob had the bit, and he proposed to keep it.

"We must jump!" cried Ralph, saking with fright.

"Crawl out behind!" panted Cale. "Don't jump sideways! You'll be killed!"

Ralph took this advice at once, and in a moment lay in a groaning heap in the dust of the road, but not seriously injured. Cale made no move to follow him, however. The black horse was liable to do unmeasured damage if left with no one to guide him (he still answered to the rein as far as guidance went), and the boy could not make up his mind to follow Ralph.

Not far ahead was the long, covered bridge which crossed the river. It was so narrow that vehicles could just pass in its semi-darkness. If the runaway entered the bridge without somebody to guide him, and should meet another turnout, there would be a most frightful catastrophe.

Cale stood up to get a greater purchase on the creature's bit, and at that instant they swung around a turn and the entrance to the bridge came in view. Driving slowly out of it was the carriage-load of girls behind the sorrel horses. The sorrels were slow, and the instant the girls saw Black Bob plunging toward them they screamed and lost all presence of mind. The one who drove dropped the reins and covered her eyes with her hands. The old farm-horses stopped stock-still in the dusty roadway.

There was not room to turn out safely. Cale saw that at a glance. Had the team been out of his path he could have crossed the bridge and tired the black horse out on the steep hill on the other side. But he could not pass. It seemed impossible to avert the awful crash. The boy, his face white, his sandy hair flying in the wind, gave a last despairing tug at the lines. Black Bob plunged on with unretarded pace.

Suddenly a thought flashed into the boy's brain. If he clung to the lines, and guided the runaway as near the ditch as possible, he might get through safely himself. He was going with such speed that the other carriage would be the one most injured in the collision. A second thought followed in the train of this, however. There was just one way in which he might avert the collision and save the girls. He dropped one rein altogether, and with both hands gave the other line a mighty jerk. The leather parted, but Cale had done what he intended. The great black horse was hurled with terrific force to the ground. Cale shot over him, landing in the ditch beside the road, and lay there motionless. The black horse, too, did not move, excepting for the twitching of his great muscles. His neck had been broken!

The girls found sense enough to do something besides scream then. They hastened to poor Cale's assistance. Ralph, much rumped and bruised, came limping up, and with his help they managed to lift Cale into the carriage and get him home.

Nobody called the hired boy a "clodhopper" now. The careless minds of the young people were stung by the lash of remorse, and the older guests wondered why they had never noticed the good qualities in the boy before. Death hovered very closely over Cale for the next few days, and it was far into the fall, and the visitors had long ago returned home, before he was about, even on crutches, again.

He will probably never be the strong, rugged fellow he once was; but Ralph Armstrong and his cousins declare that he won't need to depend on his muscles for a living in the future. They discovered that beneath Cale's uncultured surface were some talents which will bear cultivation, and they have a scheme afoot to send him to a school of technology, which had long been his dream.

\*A similar act of bravery was performed on the Speedway, near New York City, in the summer of '99.

ELECTRICAL DIVINING-ROD

The most notable patent for a divining-rod, or metal-finder, was issued recently. Several patents had previously been granted for mechanical and electrical contrivances designed to locate gold, silver and other ores, and a great many applications have been rejected for various reasons. The commissioner of patents would not, for example, issue a patent for a witch-hazel divining-rod, because that has been in common use for centuries, and comparatively few of the devices that have been offered in this line involve original or meritorious features. To secure a patent the usefulness and practicability as well as the novelty of an invention must be demonstrated, and the divining-rod in various forms has been in use ever since the time of Jacob. Few people realize the extent to which the divining-rod and its substitutes are used at the present day to locate minerals, springs of water, subterranean rivers, hidden treasure, etc. There are people in New England who still earn a living that way, and that is supposed to be the seat of our highest civilization and greatest intellectual attainment, although, as I have frequently stated, the statistics show a higher degree of education in Iowa, Kansas and Nebraska. Large numbers of successful oil-wells in Pennsylvania, Ohio and Indiana have been and still are bored at points designated by "oil-smellers," as they call them; prospectors in the mining regions use magnets and all sorts of electrical appliances, and in almost every county of the United States in the agricultural districts you will find farmers who still believe in the efficacy of a split rod of witch-hazel. As late as 1876 Mr. Charles Lattimer, of Cleveland, a well-known engineer, wrote a book to demonstrate its uselessness in determining subterranean water-passages. The "dousing-rod," for the same purpose, is made of two prongs of whalebone, with one end of each fastened firmly in an empty cartridge-shell. Similar divining-rods were used in the time of Moses and Aaron. Marco Polo found them in China. Philip Melancthon, the religious reformer and friend of Martin Luther, testified to their efficacy and defended them from the Inquisition, by which they were denounced and prohibited. Divining-rods have commanded the faith and confidence of all races in all countries in all times, and there has been little improvement in the design. Electricity is now used, however, for such matters more than the ordinary rod of witch-hazel, and, as in the recent patent granted to Mr. F. H. Brown, the operator usually connects with an ordinary battery two wires which are attached to two stakes. When he reaches a place where he suspects minerals may be found, he drives the stakes into the earth, turns on the current, and if the circuit is completed by a body of ore in the earth a bell or some other annunciator connected with the battery will announce the discovery. Springs of water and subterranean streams can be located in the same way. A simpler device consists of a rod with an electrical battery and a wire on the top and a wire running down the center. This rod is driven in the ground, and if the end comes in contact with ore or minerals of any kind the result is felt by the operator.—Boston Transcript.

BRIDES WITH CLOSED EYES

"A Corean bride has her eyelids pasted together until she has been three days a wife," said Mrs. L. S. Baldwin, in the New York "Sun," who has lived for more than twenty years in China and Corea, and who is considered among missionaries to know more about the Hermit Nation, as the Coreans are called, than any other foreigner. "Notwithstanding this rather unpromising beginning, the life of the Corean woman, while secluded, is not as unbearable as that of the women of many other Oriental nations. They are poor, and consequently compelled to work very hard, but as a rule are well treated by their husbands. They have pretty names, meaning plum-blossom, treasure, etc., but after marriage are known only as So-and-so's wife, until they have a son, after which they are known as the mother of that son.

"As a little lass the Corean girl is taught all about the domestic work, and begins early to assist her mother in making family clothes. If too young to paste, she can at least hold over the stove the long iron rod to be used in pressing seams. The heating of this rod is the first thing taught a little girl. Later she learns how to paste clothes together, then to wash and iron them. Now, this use of paste instead of thread is a custom, so far as I know, practised only by the Coreans. It is done on account of their mode of ironing. To accomplish this difficult feat they rip their garments to pieces before putting them in water. After washing the garments are laid on a smooth block of wood or stone and are beaten smooth with ironing-sticks. These sticks resemble a policeman's club, and each ironer uses two.

"In the choice of his first bride the Corean leaves everything to the go-between. But of all other wives (and a Corean may have ten) the man makes his own selection. It is seldom, however, that a second wife is added to the household, except where the first wife proves childless. In such instances other wives are taken, but the dignity always remains with the first wife."

# ESTEY

## Some People Want the Best

Catalogue free.

ESTEY ORGAN CO.,  
Brattleboro, Vt.

and the best, while not always the lowest priced, is always the most satisfactory, and the cheapest in the end. Many an Estey 25 years old is as good as new.

FOR SELLING OUR JEWELRY NOVELTIES. Watches, Cameras, Bracelets, Gold Rings, given away ABSOLUTELY FREE for selling our Jewelry. No money required. Send us your name and full address on a postal card, and we will send you 18 gold plate scarf and stick pins, all set with different colored stones, to sell for 10 cents each. The best sellers offered by any firm. When you have sold them we will send you your choice of a Watch, a solid Gold Ring and any other valuable premium on our large illustrated list, which we send you with the pins. We pay all postage.

NOVELTY MFG. CO., 82 Bailey St., Attleboro, Mass.

12 PAIRS OF STOCKINGS OR SOCKS for 10¢

JUST THINK OF IT! ONE DOZEN Pairs of LADIES' or CHILDREN'S STOCKINGS or MEN'S SOCKS, assorted as desired in any size, FOR LESS THAN ONE CENT A PAIR, which if bought in the stores would cost you from 25 cents to 75 cents per pair. For full particulars address THE PEOPLE'S SUPPLY CO., Dept. 51, Wilkes-Barre, Pa.

YOU MAKE \$5.00 A DAY EASY

Gold, Silver, Nickel and Metal Plating. At home or traveling, taking orders, using Prof. Gray's Machines. Plates Watches, Jewelry, Tableware, Bicycles, all metal goods. NO EXPERIENCE. Heavy plate. Modern methods. No toys. We do plating, make outfits, all sizes. Complete, all tools, lathes, materials, etc., ready for work. The Royal, new dipping process, quick, easy. We teach you the art, furnish secrets formulas free. Write today. Pamphlet, samples, etc. FREE.

G. GRAY & CO., Plating Works, CINCINNATI, O.

Do You Suffer With PILES

Send us your name and address, and let us mail you our Booklet—"FACTS," about MERTANNO the only specific for the non-surgical treatment of PILES.

Our Guarantee: We will refund the price paid for this remedy in any case of Piles it fails to relieve or cure.

MERTANNO PHARMACAL CO.,  
422 Scott Street, Covington, Ky., U. S. A.

\$1,000 SALARY PER YEAR!

Ladies or Gentlemen We have shared the general prosperity of the country, and we now need one or two permanent representatives in each state to look after our interests, manage our agents, and attend to collections. This position involves no canvassing and is a bona fide weekly salaried position, with all expenses paid, to the right party. It is mainly office work conducted at your own home, with an occasional trip out among the agents. No investment required. Also three salaried vacancies in the traveling department. Enclose references and self-addressed stamped envelope to PROVIDENCE CO., 144 Carlton Bldg., CHICAGO.

MONEY MAKER For AGENTS

OUR ALL METAL NEW STYLE PASTRY BOARD is perfect. Can be sold at sight to every housekeeper. If you won't stick to it. Has 20 advantages over others. W. H. Onie, Homestead, Pa., writes, "I made \$106.50 in 17 days selling your Board." Other agents are doing as well. Write quick for catalogue, TEXAS AND MODEL.

METALLO BREAD BOARD CO., Cambridge, O.

Telephones

First-class business Telephone for connecting homes, offices, stores, factories, barns, etc. Saves time and trouble. Any one can put it up with our directions. \$2.85 each. Send money-order for sample pair or write for catalogue electric supplies and novelties. Liberty Electric Co., Liberty Bldg., New York.

ECZEMA

Facial Blemishes, Tetter, Salt Rheum, Barber's Itch, Scald Head, Ring Worm, Itching Piles, Sore Eyelids, and all Skin diseases promptly cured by Spencer's Ointment. Sent to any address on receipt of 25c. A. O. PILSON, Pharmacist, 1827 W. Baltimore St., Baltimore, Md.

RUPTURE

Sure Cure at home; at a small cost. No operation, pain, danger or detention from work. No return of Rupture or further use for Trusses. A complete, radical cure to all (old or young). Easy to use; thousands cured; book free (sealed). DR. W. S. RICE, Box F, Adams, N. Y.

ARE YOU ASHAMED OF YOUR FACE?

Love by face, beautiful neck, can be had by all who send five 2-cent stamps for postage, wrapping, etc., of a large trial size of our Great Beautifier; we will also send a package of Arabian Sachet and a booklet on beauty, all free. Goodwill Chem. Co., Room 229 Wamsley Bldg., Balto., Md.

GOLDMETER

In pocket case for hunting silver, gold and tin. Gold and Silver, also Rods and Needles, Circular 2 cents. B. G. STAUFFER, Dept. F. F., Harrisburg, Pa.

WHY SUFFER

Orange Pile Cure cures Piles permanently. Instant relief. Never known to fail. By mail 50 cents. DR. M. E. MOREY, ROCHESTER, NEW YORK.

OPIUM

and Liquor Habit cured in 10 to 20 days. No pay till cured. Write DR. J. L. STEPIENS CO., Dept. A3, Lebanon, Ohio.

We Pay \$18 A WEEK AND EXPENSES

to men with rigs to introduce our Poultry Compound. Send stamp. Javelle Mfg. Co., Dept. 58, Parsons, Kan.

RUPTURE CURED while you work. You pay \$4 when cured. No cure, no pay. ALEX. SPEIRS, BOX 525, WESTBROOK, MAINE.

Coe's Eczema Cure \$1 at druggists. 25c. size of ns. COE CHEM. CO., Cleveland, O.

## Sterling Silver Bracelet . . . .

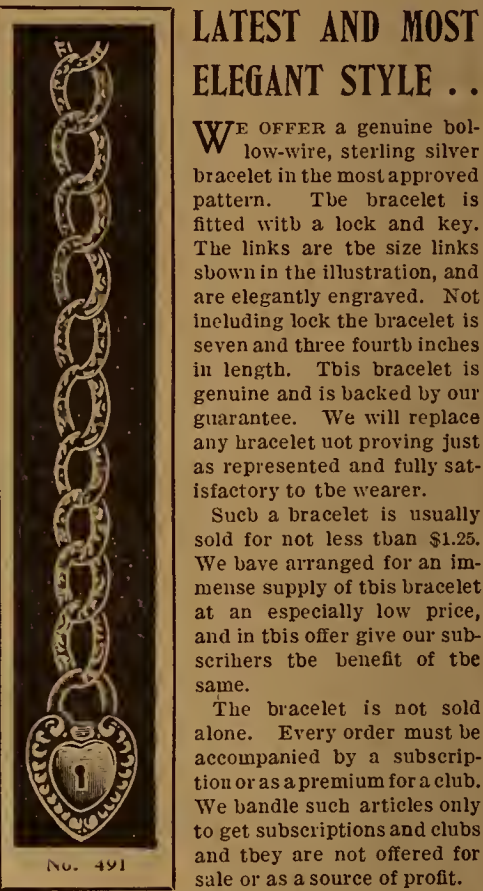

LATEST AND MOST ELEGANT STYLE . .

WE OFFER a genuine low-wire, sterling silver bracelet in the most approved pattern. The bracelet is fitted with a lock and key. The links are the size links shown in the illustration, and are elegantly engraved. Not including lock the bracelet is seven and three fourth inches in length. This bracelet is genuine and is backed by our guarantee. We will replace any bracelet not proving just as represented and fully satisfactory to the wearer.

Such a bracelet is usually sold for not less than \$1.25. We have arranged for an immense supply of this bracelet at an especially low price, and in this offer give our subscribers the benefit of the same.

The bracelet is not sold alone. Every order must be accompanied by a subscription or as a premium for a club. We bundle such articles only to get subscriptions and clubs and they are not offered for sale or as a source of profit.

We Will Send This Sterling Silver Bracelet, and the Farm and Fireside One Year, for . . . . \$1.10

(When this offer is accepted the club-raiser may have either the regular cash commission or the name may be counted in a club)

This Sterling Silver Bracelet given as a premium for a club of SIX yearly subscriptions to the Farm and Fireside.

Order by the number as given under the Bracelet

ADDRESS FARM AND FIRESIDE SPRINGFIELD, OHIO

## Side-line Agencies

Our agencies are worked on three different plans at agent's option. They pay exceptionally well. Some are particularly suited for work at odd times, or as side-lines. One of them is making book-agents and others as much money as any other two in America. We furnish outfits FREE that are good for a business of \$5 to \$8 per day. We furnish even our costliest outfits on a plan by which they do not take one cent from the agent's pocket. For full particulars address The Crowell & Kirkpatrick Co., Springfield, Ohio.

\$900 Salary and Expenses Guaranteed

Energetic and trustworthy men and women to travel, appoint agents and make collections. For an old established corporation with \$200,000 capital. Unusual opportunity. Position permanent. Rapid promotion. "Universal," Lock Box 733, Phila., Pa.





ALL IN THE DAY'S WORK

BY MARCIA TYNDALE

All in the day's work, tired heart;  
Lift the load bravely and do thy part,  
God will do his;  
"And be the day weary, or be the day long,  
At last it ringeth to even-song!"

All in the day's work—straight from thee  
Comes the right task Love sets for me;  
I will attempt it;  
"For be the day weary, or be the day long,  
At length it ringeth to evening song!"

All in the day's work—let it be  
Or short or long, 'tis all for thee—  
Singing I'll do it;  
"And be the day weary, or be the day long,  
I shall sleep to awake with the angel's song."  
—Parish and Home.

HOW BOYS ARE SPOILED

BY MRS. A. M. MARRIOTT

WHEN farmers are lamenting the fact that their boys are dissatisfied, and are leaving the farm for places and positions elsewhere—anywhere, in fact, except at home—they should look over their ways of managing and see if they cannot discover the cause. A boy is a very human sort of an "animal," and is very easily influenced; and although his vision may not have the "front and back" action claimed by his elders, he can see some things much more clearly than they think, and it does not take him long to see whether the cattle, hogs and horses on the place are the ones to be treated as having immortal souls, or the boy who takes care of them.

A man who will keep a lot of young cattle stabled in a filthy barn through a whole winter without an effort being made to remove the filth, which gets matted down, and when spring comes must be chopped and dug loose to the depth of two feet, and hauled out over the fields by his boy or boys, never should have had the boys to train. If he is willing to work side by side with them, and not excuse himself on the "press of business," it would not be so bad, either, for any boy will work very well and not complain if "father" is there taking his share, too. He knows he will get nothing for the hard, disgusting work, only a scolding if he doesn't keep right at it day after day; his head may ache from the strong fumes, he may complain of feeling sick, but it's "Now you keep on at that manure-hauling, and see that you get that job done; we've got to hurry while we can use this team!" This while he is making a grand rush for the "business," which consists in a great deal of "whiz around," and which covers a vast extent of territory covered with "things that are better than work."

If the boy hurts himself in any way, has a lame back or leg or arm, and there is a hired hand needing some one to work with him, just send the boy, and give him plenty to do making posts, felling trees, splitting, sawing, chopping or maning; "it is good for a boy's muscles, and will toughen him." At the same time, and in a far greater ratio, will the muscles of his heart grow tough toward the one who cares so little for the aches or pains of any one but himself. Boys should be taught to feed and care for stock, but why all the hard and dirty jobs should be put onto them they very naturally fail to see.

The farmers whose boys stay with them and respect them are the ones who treat the boys white and show them some consideration. Of two men, here is the difference: One has a family of seven boys, who cling to their home on the farm like "ticks;" and while they are all good workers they all love and respect their father. He acts like he is one of them and not a would-be emperor. He feeds hundreds of cattle, and uses a great deal of corn, most of which he buys by the car-load. The other man believes in getting all he can out of his boys and

teams. They were speaking of hauling a ear-load of corn to the home of the former. The latter said, "With your force and your teams you ought to get that corn out there in a day or two." "Oh, no," said the other; "don't overwork, don't overload; plenty of time." There, thought I, is the secret; Mr. A looks beyond the moment, while Mr. B sees only the penny gained by using every pound of strength and every atom of time. Will not those boys always think tenderly of the father who had his boys' welfare first in his mind?

OVERWORK

Overwork sometimes does kill the physical and mental man, but it is not overwork outdoors that does so. It is overwork in a close, hot room, in a stifling atmosphere in the unhygienic district of an overcrowded city. The "man with the thimble" sewing on "pants" for fifteen cents a dozen may have a grievance against society. He may say that he is not given "elbow-room and a fair chance." But he is a product of another civilization damped on our shore, poorly equipped for the struggle of life, his body enfeebled and his soul eroding by the remembrance of centuries of oppression. Call our attention to him, remind us in ringing tones of our duty to our forlorn, oppressed brother, O poet! and you will be doing society a service if you can make us see the dangers of indifference to suffering. If you can penetrate our hearts even a little the service will be the most valuable a man can render humanity. But let the "man with the hoe" alone. He is all right.—Hartford Courant.

TRUTH-TELLING IN CHILDHOOD

Children will probably tell the truth if they are surrounded by an atmosphere of perfect sincerity. But we must discriminate between falsehood and a vivid fancy or fervent imagination in a small child. Said a wee maiden of three the other day, "I was walking along the garden and I met a wolf, and the wolf wanted to eat up my dolly, but I frightened him away." The little one has heard fairy-stories and has mixed them up with the daily occupation of her life. If a timid child be treated with severity he may be alarmed, and thus led to violate the truth. If promises made a child are broken he will learn to set a light value on the plighted word. If the habit of the elders is to prevaricate, to evade or to exaggerate, the child will learn this in some measure; and, in short, the only way to teach a child absolute truth is to be always and everywhere and continually truthful when with the child.—Christian Intelligencer.

HOW TO READ

We may read ourselves full or read ourselves empty, according as we merely take in what we read or use our reading to stir us into thinking or saying something. Reading should wake a person instead of putting him to sleep, and should always set him to doing something else than reading.

Men can often do something better than get more information, and reading should not be a means of escaping work. We should never do a duty which prevents us from doing one that is greater; reading for entertainment may be no better than drinking for entertainment.—From "Reading with a Purpose," by Austin Bierbower, in the Chautauquan for May.

A SEED-THOUGHT

When you come down from the summits you do not come away from God. There is no task in life in which you do not need him. The work-bench needs his light as truly as the cloister.—Phillips Brooks.

INFLUENCE OF MUSIC

"Music is a thing of the soul," said J. G. Holland; "a rose-lipped shell that murmurs of the eternal sea; a strange bird singing the songs of another land." And how true it is, for what an inspiration there is in good, pure music, coming from a music-loving soul. As an educator it expands the mind and inspires the soul to higher and better things of life, and as a great factor in education it is almost beyond comparison with anything else, for there is something in music that plays on the heartstrings with sweetest harmony, and the soul is touched with a beauty likened only to dewdrops sparkling on the sweetest flowers.

There are those that have never as yet felt the full impressiveness of good music, but there is hardly a human being that has not a few coals of smoldering music passion in their breast, and some time it will flame up and burn with a fierce longing for good music, and as its cadences fall on the heart we can rest in its inspired presence.

To the burdened heart it comes as a loving sympathizer, ever ready with its tenderness and sweetness of melody to cheer where gloom has driven sunshine away, and with unspeakable joy we feel its great power impressing our heart and soul, while our thoughts are lifted to a higher pinnacle, where happiness and joy are found. Music to the happy heart is like silvery raindrops falling on the window-pane; it brings with each drop cleanness and purity, while the soul is bathed in showers of love and peace. To me the inspiration of music here is something akin to that in heaven, for this is only the first few strains of a grand and glorious melody being rendered up there. Sometimes our souls feel so inspired with music and its sweetness that it would seem easy to mount the great musical stair, with a light, airy step, and garner into our hearts the best and purest of music. A mother's voice is ever held in fond remembrance after death has called her, for we loved to hear her voice as it rose and fell in low, sweet songs of lullaby, and though other things may escape our memory, mother's singing can never be forgotten.

On its grand and ennobling missions it visits the poor and the rich, is restful to the tired laborer, soothing to the sleepy infant, comforting to the mourner. No place is complete without it, for it brings with it education to life's purest and best. Music has made many death-beds easier, and although it may have been a song sung by some trembling weak voice, while the Angel of Death was slowly beckoning the soul to come up higher, it departed from this world, perchance, with a few broken chords feebly uttered, to be rendered in perfect harmony around the throne of God up there.—Exchange.

OUR THOUGHTS

The affections are the pulse of the soul. If we would know its state we must observe how that pulse beats. How do I stand affected to sin? Do I dread it as most dangerous, loathe it as most odious, and complain of it as most grievous? Or do I make light of it? Which lies the heavier, the burden of sin or the burden of affliction; and of which am I the most desirous to be relieved? What do I think of Christ? Do I love him and prize him as the fairest among ten thousand? Or hath he in mine eyes no form nor comeliness, and is he no more than another beloved? How do I stand affected to the word and ordinances? Are God's tabernacles amiable to me, or are they despicable? Am I in God's service as in my element, as one that calls it a delight? Or am I in it as under confinement, as one that calls it a drudgery? How do I stand affected to good people? Do I love the image of Christ wherever I see it, though it be in rags or though not in my own color? Do I honor them that fear the Lord, and choose his people for my people in all conditions? Or do I prefer the gaities of the world before the beauties of holiness? How do I stand affected to this world? Is it under my feet, where it should be, or in my heart, where Christ should be? By such inquiries we may come to know our own selves.—Matthew Henry.

FREE

We will send this Repeating Air-rifle Free for a Club of SIX yearly subscriptions to the Farm and Fireside. (See shipping directions below.)

A NEW REPEATING

AIR-RIFLE

We here offer the new 1900 Globe Air-rifle, which has several important improvements, making it one of the best Air-rifles ever sold for the price.

Description

The Rifle is made of excellent material. It is 32 inches long, with nickel-plated barrel. It has a globe sight and wooden stock. It is simply and strongly made. Any boy can operate it. It is a very hard shooter. It will carry a bullet a long distance. It is easily and quickly loaded.

Shoots 300 Times

The ammunition-chamber in the Repeater holds over 300 bullets. The Repeater is operated by pressing down a spring after each shot. The ammunition is B. B. shot, which is for sale in stores everywhere. Ten cents will buy about 1000 bullets. Owing to its accuracy, hard shooting and the cheapness of its ammunition, this new Globe Air-rifle is very popular alike with grown-up people and boys. By a little practice remarkable skill in marksmanship can be attained.

We guarantee each and every Rifle to arrive safely and in perfect condition and to be as described and to give entire satisfaction or money refunded.

A club-raiser's outfit will be sent free to any one who wants to get up a club.

Premium No. 481

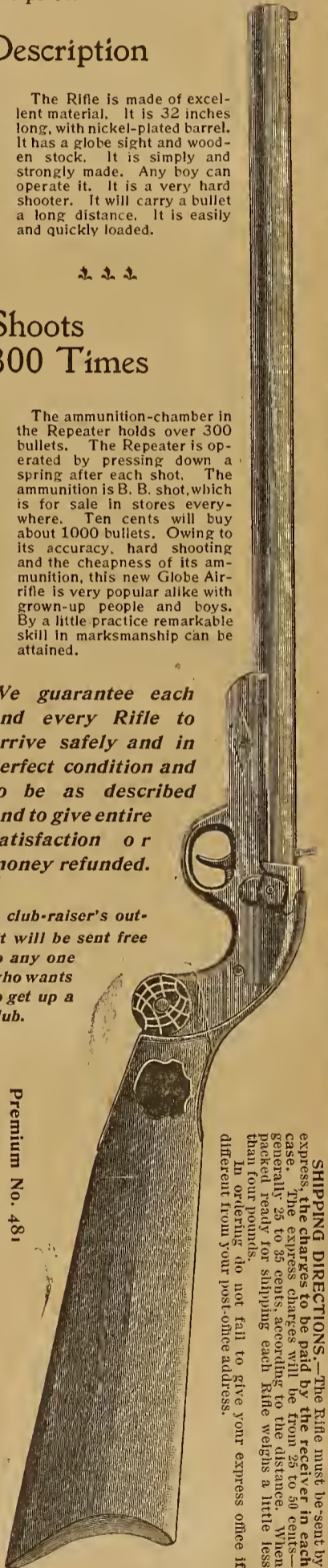

We will send the Farm and Fireside One Year and this Air-rifle for

\$1.50

(When this offer is accepted the club-raiser may have either the regular cash commission or the name may be counted in a club)

Renewals and club-raiser's own subscription can be counted in a club. Address

FARM AND FIRESIDE  
SPRINGFIELD, OHIO





"A LITTLE BIRD TOLD ME"

"Bill," said the small boy to the bird, "I'm fond of you, upon my word. But lately I have not been able to take an apple off the table, Or from the pantry swipe a cookie, Or jam, or even play at hooky. But mama gets right at the facts No matter how I bide my tracks. And then she turns me on her knee, And, crackey! but she wallops me! And when I ask, 'Who told you, ma?' She only laughs and says, 'Aha! A little birdie watches you And tells me everything you do!'"

"Now, Bill, perhaps you're not the one, But chances I don't like to run. So get this through your head, somehow—I'm going in the pantry now To sample every jar and dish And eat just everything I wish; And—listen, Bill, if any one Should ever hear what I have done, Remember what I've said, and that I'll—well, I'll feed you to the cat!"

—Life.

NOT HIS TAILOR'S FAULT

His trousers' legs, as here you see, Are never built amiss || But when he draws the garment on They always look like this ( ).

—Chicago Tribune.

AN AWFUL AFTERTHOUGHT

YOUNG Mrs. Torkins seemed very much worried when her husband came home in the evening.

"What's the matter?" he asked, sympathetically.

"Oh, Charley, I'm so afraid I've made enemies!"

"Why, you haven't done anything to harm anybody or hurt their feelings, have you?"

"Not intentionally. But you know how likely we are to be misunderstood. I'm afraid those people who have moved next door will never speak to us again. And I'm so sorry! They seemed like such nice people. They sent the servant-girl they brought with them from Boston over here this morning to borrow something."

"Well, they're just getting settled. You ought to accommodate them in any way you can."

"That's what I thought. So when the girl came over and asked our girl to lend her a mop, I told her to give her the best mop in the house, and if we hadn't a good one to go around to the store and buy a new one."

"That's right."

"But, Charley, have you heard them talk?" "A little. They all broaden their 'a's' after the manner of Boston. It sounds very pretty and precise. I like to hear it."

"Yes. But it is so confusing. A mop was such a funny thing for cultivated people like them to ask for. I shouldn't be a bit surprised if they were reading some war news, and what they wanted to borrow was a map, and—oh, dear—I think maybe I'd better put on my things and go over right away and try to explain!"—Washington Star.

FOREIGN BUT PERTINENT

A Sunday-school superintendent always conducts the lesson review in his school. He spends about five minutes in explaining the lesson, and then asks, "Now, has any one a question to ask?"

Last Sunday he explained the lesson as usual, dwelling at length on its chief thoughts, and wound up with the usual question, "Now, has any one a question to ask?"

A member of the boys' junior class raised his hand.

"Well, what is your question?" asked the superintendent.

"Please, sir, are we going to have a picnic this summer?"—Omaha World-Herald.

THE EIGHT-HOUR WATCH

"What?" cried the labor leader, as he entered the house, "no supper yet!"

"No," replied his wife, calmly. "You will recall that I began work at six o'clock this morning."

"What has that to do with it?" he demanded.

"My eight-hour watch expired at two o'clock this afternoon," she answered.—Chicago Post.

MAN'S OBITER DICTUM

He—"There are two periods in a man's life when he never understands a woman."

She—"Indeed! And when are they?"

He—"Before he is married and afterward."

WON HIM A BRIDE

Major J. M. Burke told a good story of his experience in helping a friend to get the girl of his choice.

"He was a good fellow," said he, "but young and without capital. The girl was a beauty, and loved the boy, but the father (the same old irate father) objected and demanded that the boy show that he was capable of supporting a wife. This was in St. Louis about ten years ago, and the boy came to me with his troubles."

"'Never mind,' said I. 'I'll fix it up all right. By the way, how much will you take for your right leg?'"

"He looked at me as though I were crazy, but made no answer."

"'I'll give you ten thousand dollars for it,' I said. 'Will you take it?'"

"'No, I won't,' he said. 'What do you take me for?'"

"Well, I knew the girl's father; he was a merchant, and I called to see him. We finally drifted around to talking about this young fellow, and the old man flared a little, stating that he wanted some one who could support a wife to have his daughter."

"'Support a wife!' said I, in surprise. 'Why, be certain you can do all that. Only a few days ago he refused ten thousand dollars for a piece of property.'"

"'His own property?' asked the father. 'Certainly,' said I."

"'Who offered him the money?' asked he. 'I did; and he refused it,' I answered. 'He claimed it was worth more.'"

"Well, this made a hit, and no more questions were asked. The boy is doing well now, and has a good family. I haven't spoken to the father since."—Washington Times.

THOSE GARDEN-SEEDS

A Western Congressman recently received the following note from one of his rural constituents to whom he had sent a consignment of garden-seed: "Kind sir and esteemed friend, I have the seeds. They came this morning, and suit very well, specially the cabbage-seed, which grows well in this soil. Please send me two loads of fertilizer and a new harrow, and if you could send me a man for a couple of days I would be obliged. With this help I know the garden stuff will turn out all right and I will send some to you and the president. Your grateful well-wisher and supporter."

"SURPRISE" PUDDING

"My dear," said young Mr. Marage, "what is this dessert, anyway?"

"It's called surprise pudding," replied the dear young thing. "I tried to make bread, but it wouldn't rise for me, so I just made a nice wine sauce for it and made a dessert of it."—Philadelphia Press.

HIS UNANSWERABLE PRAYER

The layman—"Candidly, do you expect your prayer in behalf of the Boers to be answered?"

The pastor—"I flatter myself it is unanswerable, sir. Three or four cranks have tried to answer it through the press, but it seems to me they have failed egregiously."—Detroit Journal.

A HAPPY COMBINATION

"No," said the clerk, "I should not advise you to get a big, flaring hat, because it would not be becoming to you. And the best hats are smaller this spring, anyway."

"Oh, I'm so glad," the lady replied, "for we've just decided to move into a flat."—Chicago Times-Herald.

AS OTHERS SEE US

New-Yorker—"What do you think of our street-cars?"

Englishman—"They seem to be very comfortable for those persons who prefer to stand."—Judge.

A DIFFICULT CURE

Patient—"Well, doctor, what do you think of the swelling on the back of my neck?"

Doctor—"I don't like the looks of it, as it is in a very dangerous place. My advice to you is to keep your eye on it."

A MENTAL EFFECT

"Marle, why on earth didn't you look pleasant when you had your photograph taken?"

"I couldn't, Edmund; I kept thinking how you would seold if I didn't."—Puck.

CUT BOTH WAYS

In an interval in the drilling one of the volunteers belonging to a crack regiment stepped out from the ranks to light a cigar from that of his officer.

The latter took this evidence of the democratic spirit of freedom in good part, but said, by way of a hint, "In the regular army you couldn't have done this to an officer, Brown."

"Right you are," responded the private; "but in the regular army you could not be an officer."—Collier's Weekly.

THE POINT OF THE STORY

Mama (anxiously watching her little boy at dinner)—"My dear child, you really should not eat your pudding so quickly."

Small child—"Why not, unama?"

Mama—"Because it is dangerous. I once knew a little boy about your age who was eating his pudding so quickly that he died before he had finished it."

Small child (with much concern)—"And what did they do with the rest of his pudding, mama?"

THE FAT MAN'S TROUBLE

Higgins—"Well, has Dr. Green given you any relief? I suppose you took my advice and called him in?"

Twentystone (troubled with obesity)—"Look here! Did you send him to me to poke fun at me?"

Higgins—"Eh! No! Why?"

Twentystone—"Because, the first thing he asked was, 'Do you feel heavy when you get up in the morning?'"—Philadelphia Press.

IT'S UP TO PAPA

"I would like to know," said the gruff old father to the young man who had been calling with considerable frequency, "whether you are going to marry my daughter?"

"So would I," answered the diffident young man. "Would you mind asking her?"—Scraps.

REMARKABLY RESERVED

"Shrinkshy is a very reserved man." "Yes, indeed. Of course, I don't know, but I honestly believe he could have a toothache without any one knowing it."—Harper's Bazar.

PAPA'S THEORY

Mama—"I can't imagine what baby is crying for now."

Papa—"Just to keep in practice, I suppose. He may not want anything just now, but he can't tell when he will."

BRINGING HIM TO THE POINT

Mr. Slowboy—"There's a big strike on in the jewelry trade."

Miss Waite—"I wonder if there's any danger of a failure in the ring supply?"—Jewelers' Weekly.

A TEST OF THE VIRTUES

Faith, hope and charity are unquestionably the principal ingredients in the make-up of a man who lends his umbrella to a friend.—Chicago News.

EVEN UNTIL DEATH

Author—"Why do you say that my story isn't true to life?"

Editor—"Because you make the hero true to death."—Harper's Bazar.



Henretta—"Do you believe in signs?" Roosticana—"Not when they read of chickens at ten cents a pound."—Seattle Post-Intelligencer.

CHARLESTON-BY-THE-SEA

National Educational Association, Charleston, S. C., July 7th-13th. Low rates Queen and Crescent Route and Southern Railway. Write for free books to W. C. Rinearson, G.P.A., Cincinnati.

BEST FOR THE BOWELS

If you haven't a regular, healthy movement of the bowels every day, you're sick, or will be. Keep your bowels open, and be well. Force, in the shape of violent physic or pill poison, is dangerous. The smoothest, easiest, most perfect way of keeping the bowels clear and clean is to take



Pleasant, Palatable, Potent, Taste Good, Do Good, Never Sicken, Weaken, or Gripes. 10c, 50c. Write for free sample, and booklet on health. Address Sterling Remedy Company, Chicago, Montreal, New York. 322a

KEEP YOUR BLOOD CLEAN

For a Summer Outing

THE Rocky Mountain regions, reached via the UNION PACIFIC, provide lavishly for the health of the invalid and the pleasure of the tourist. Amid these rugged steeps are to be found some of the most charming and restful spots on earth. Fairy lakes nestled amid sunny peaks, and climate that cheers and exhilarates. The

Summer Excursion Rates

put in effect by the UNION PACIFIC enable you to reach these favored localities without unnecessary expenditure of time or money.

In effect June 21, July 7 to 10 inclusive, July 18 and August 2. One fare plus \$2.00 for the round trip from Missouri River to Denver, Colorado Springs, Pueblo, Ogden and Salt Lake City. Return limit October 31, 1900.

For Time Tables and full information call on your nearest agent or address

A. G. SHEARMAN, General Agent Passenger Dept. U.P.R.R. Co. Room 36, Carew Building, Cincinnati, Ohio

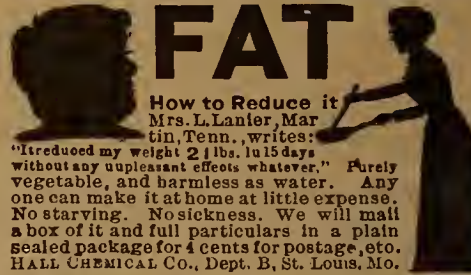

Advertisement for Gold Pens Free... Premium No. 91. The Pearl Pen. The Fountain-pen. We will send the Farm and Fireside one year and either of these \$1.00 Pens for \$1.00. (When this offer is accepted the club-raiser may have either the regular cash commission or the name may be counted in a club) Both pens guaranteed to give entire satisfaction or money refunded. WE PAY THE POSTAGE ADDRESS FARM AND FIRESIDE SPRINGFIELD, OHIO





HOUSEHOLD

[CONTINUED FROM PAGE 11]

A SUMMER SONG

"Move slow, sweet June! Sweet June, move slow,

And let the apple-blossoms blow  
A little longer; let the sky  
Bend backward as the clouds pass by.  
My darling, look," she said, "and write  
A song with this refrain to-night."

"Oh, stay, sweet June, thy flowery feet—  
Thou art so sweet; thou art so sweet!"

"Move slow, sweet June, move slow,"

I sang, and watched the lilies blow,  
And saw the dandelions shime  
Upon a hand held close in mine;  
"Oh, stay until the robins sing  
Once more," our hearts kept whispering;  
"Stay, stay, sweet June, thy flowery feet—  
Thou art so sweet; thou art so sweet!"

"Sweet June, dear June, no longer stay;  
Alone I sing to-day, to-day;  
Oh, linger not, stop not to tell  
The tale I used to love so well,  
But hasten, June, for I would go  
Where flowers immortal bud and blow.  
Dear June, sweet June, no longer stay—  
Thou art so sad, so sad to-day!"

"And yet, dear June, dear June, and yet  
Thou still art sweet. Do I forget  
How many hearts are glad as mine  
In other Junes? Oh, blot that line,  
That verse, my hand! Let lovers sing  
To-day, let children's voices ring  
With joy; for them delay thy feet,  
Sweet June—thou art so sweet, so sweet!"  
—Julia H. May.

VACATION SUGGESTIONS

NO MATTER whether you ever had a real vacation in your life or not, begin now to plan some delightful bit of recreation. Probably your plans will not materialize as you expect them to—they don't always in this workaday world—but a little harmless building of air-castles is good business for the intervals of rest that come to the busiest. Only the lazy and indolent come to grief from too much dreaming, and to such I do not speak, for they are not to be found among the large number of readers of the FARM AND FIRESIDE.

It has long been a pet theory of mine that there are good times all along the way—seasons of recreation, of real up-building, for tired bodies and faded spirits—which may be had for the taking, and are not taken because they are too common to be appreciated. One who can find no beauty near at hand, no joy in a day of perfect freedom among the trees and flowers of the neighboring grove, no delight in the brook that has babbled its secrets to her since childhood, may as well give up at once the dreamed-of trip to mountains or sea-shore. Such a trip would be a weariness to the flesh, a dismal failure.

On the other hand, if one knows how to relax, how to play, and has time and money, an absolute change is well. There are rare souls to whom nothing on earth is better than "the sweet monotony" of familiar scenes; but to most of us the monotony in time becomes narrowing. We know that somehow our better natures are in need of a vigorous shaking up, and if we can afford it we "take a trip;" if we cannot afford a trip we "go a-fishing," and ten chances to one feel made over new in either case.

The essential thing is to get out of one's self, to forget cares, to "become as little children," if we would enter into the rest and joy which is doubtless a foretaste of what we will one day lay hold of for eternity. Certainly we all remember days which for pure enjoyment are not surpassed by our brightest dreams of heaven. Such days may be ours if vacation means all it should mean.

"But," say some, "we have no vacation. We cook and clean and mend and sew. Our work is never done."

So it is not; and yet there must be occasionally a day or so when work may take a secondary place. When something that we really want to do may take the place of the wholesome drudgery against which we all rebel at times.

I once knew a busy mother who had every excuse for becoming a household drudge. Her family was large, and

means were small, but her home was in the midst of a beautiful country, and she was not blind to its beauty. She had the happy faculty of letting things go once in awhile, and would become a child with her children, hunting wild flowers, going berrying or fishing, and that, too, not from a sense of duty, but for real enjoyment of the outdoor world. A woman of that sort will be ready for the larger recreation of a journey by land or water to places that are famous for their beauty and grandeur.

The great danger in settling down to an indefinite period of routine broken by not so much as a dream of change or recreation is that by and by, when the opportunity comes, the power to enjoy will have died of inanition. Get out your atlas on a hot summer day, and with the aid of the maps therein plan a trip on the lakes; let your imagination carry you far to the north, away from heat and care and worry. Even these imaginary journeys refresh one, and then who knows but there may come a vacation-time when our wildest dreams will be realized. Meantime we will take the recreation that circumstances allow us, and see to it that school-teachers do not have all the vacations as their exclusive right.

BERTA KNOWLTON BROWN.

SOME OF THE THINGS LEARNED FROM AN EXPERT

PAstry, IN WARM WEATHER.—If one would have success in making pastry she must see to it that the ingredients used are cold—very cold—and she must work very rapidly in a cool room. Some cooks use half butter and half lard for pie-crust; others prefer all lard, one tablespoonful to a pie. Some prefer to cut the lard and butter into the salted flour with a knife, adding the ice-water slowly, stirring all together with the knife; others rub the lard and butter quickly into the flour, then add water to make a dough that will not stick to the hands. If you wish the top crust to be flaky, spread it over with butter, sift flour over it, then place on your pie as you always do. Then hold the pie in one hand, slanting it a little, and taking a dipperful of cold water in the other hand, pour over the crust, rinsing off some of the flour; enough will stick to the butter to fry into the crust to give it a fine, flaky look. If you desire to ice the top crust, make a meringue by adding a tablespoonful of white sugar to the beaten white of an egg. Brush the top over with this, then set back in the oven a moment to glaze.

CHOCOLATE-CUSTARD PIE.—Have a pint of boiling water on top of the stove; stir into this a fifth of a cake of chocolate which has been smoothed in a little milk, and boil two minutes. Having the yolks of five eggs and the whites of three well beaten with half a cupful of sugar, stir into the milk, and then into the chocolate, now nearly cold. Add a pinch of salt and a little vanilla. The crusts should be baked and ready for the reception of the custard. A short time before the pies are removed from the oven spread over the well-beaten whites which have not been used in the custard sweetened with two tablespoonfuls of sugar.

POTATO-CRUST FOR MEAT PIES.—Mash six well-cooked potatoes very fine, add a teacupful of thick, sweet cream, also a little salt, and flour enough to roll out the crust. Do not handle much; do not use a lower crust; prick the upper one, to let out the steam, and place over the meat part, previously prepared.

PEACH PIE.—This pie is delicious. Make a butter by stewing dried peaches and fresh pie-plant together. Strain through a colander, and make into a pie.

SWEET-POTATO PIE.—A pound of grated potatoes, three fourths of a pound of sugar, one half cupful of whipped cream, one half pound of butter and four well-beaten eggs. Add the whites last; bake slowly.

ELLA BARTLETT SIMMONS.

N. E. A.

Reduced rates via Queen and Crescent Route from all points north to Charleston, S. C., account the great National Educational Association meeting in July. Free books. W. C. Rinearson, G.P.A., Cincinnati.



Beautiful Gold-Plated Stick-Pins

REAL OPALS AND PEARLS

THE heads of these pins are genuine sterling silver plated with gold. They are beautifully colored with blue French enamel and are the new Oriental finish. No. 574 has a real opal in the center and three real pearls. No. 703 has two real pearls. These pins are new designs, first-class goods, and are guaranteed to give satisfaction or your money promptly refunded.

We Will Send the Farm and Fireside One Year and Either of the Pins for . . . 75 Cents

(When this offer is accepted the club-raiser may have either the regular cash commission or the name may be counted in a club)

Either of the pins given as a reward for a club of FOUR yearly subscriptions to the Farm and Fireside. Order by the premium numbers.

Prem. No. 574

Prem. No. 703

FARMERS' OWN KNIFE

A THOROUGHLY PRACTICAL knife for heavy work. Blades hand-forged from the very best steel. Brass-lined, finely finished. No sharp corners to wear holes in the pocket. Genuine H. & B. goods, well known all over the United States as being hand-forged and high-class. Also a little the highest-priced goods made—that is because they are worth more. This knife usually sells in the stores for not less than one dollar and twenty-five cents.

Premium No. 273

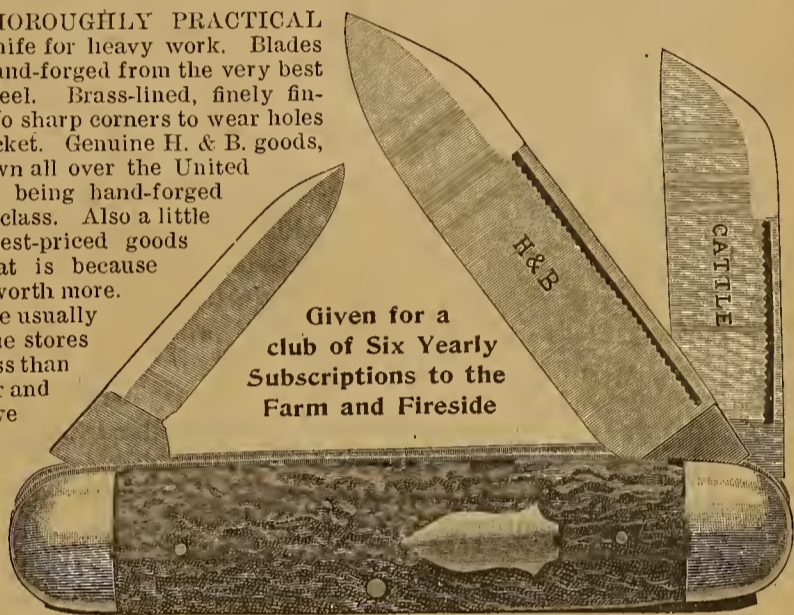

Given for a club of Six Yearly Subscriptions to the Farm and Fireside

We Will Send This Knife, and the Farm and Fireside One Year, for . . \$1.25

(When this offer is accepted the club-raiser may have either the regular cash commission or the name may be counted in a club)

Given as a reward for a club of SIX yearly subscriptions to the Farm and Fireside. Postage paid by us. Always order by the premium number.

PIE-KNIFE BERRY-SPOON

The full length of the Pie-knife is 9 1/2 inches. Width, 2 1/2 inches.

THE base of this ware is solid nickel-silver metal, which is the best white metal known for the base of silver-plated ware, because it is so hard and so white that it will never change color and will wear for a lifetime. The base of this silverware is plated with the full STANDARD amount of pure coin-silver, and is guaranteed to give entire satisfaction or money refunded.

ANY INITIAL LETTER

Each piece of this ware engraved free of charge with an initial letter in Old English. Only one letter will be engraved on each piece. State your choice.

GUARANTEE

We absolutely guarantee every piece of this ware to be exactly as it is described and to give full and entire satisfaction or money cheerfully refunded.

FREE

Either the Pie-knife or Berry-spoon will be given FREE for a club of THREE yearly subscriptions to the Farm and Fireside

Illustrations Reduced Size

We Will Send the Farm and Fireside One Year and Either the Pie-knife or Berry-spoon for

65 Cents

Premium No. 92

Prem. No. 80

(When this offer is accepted the club-raiser may have either the regular cash commission or the name may be counted in a club)

Address FARM AND FIRESIDE, Springfield, Ohio



# One Peerless Picture

And the Farm and Fireside  
the Remainder of the Year, for **25c**

*(When this offer is accepted the club-raiser may have one half the cash commission allowed on a yearly subscription or two of these names may count for one name in a club)*

**STYLE** These pictures are reproduced in the very LATEST style. In an artistic way every line and shadow of the originals is preserved in the pictures here presented.

**SIZE** These pictures, including the margins, are 20 by 25 inches in size, five hundred square inches, or about FOUR TIMES the size of this printed page. Without the margins they are about 16 by 20 inches, varying according to the subject.

The paper on which the pictures are produced is the very finest picture-paper, good and heavy, and suitable for framing.

The illustrations on this page can convey no adequate idea of the size, beauty and elegance of the pictures.

### POINTS TO BEAR IN MIND

IN CONNECTION WITH ALL THE RICH AND BEAUTIFUL PICTURES WE OFFER

1. They are the most faithful reproductions ever offered.
2. They satisfy the most critical lovers of pictures.
3. They are the masterpieces of master artists.
4. They are unexcelled for beauty and clearness.
5. They cultivate high ideals.
6. They preserve the artistic quality of the originals.
7. They are of sufficient size to bring out all the delicate effects of the originals, and are well suited for framing.
8. They preserve the life and effect of the originals much better than any other reproductions ever offered at such a low price.
9. They assist in creating an atmosphere that is most favorable to growth in pure and noble character.
10. They are the greatest achievement in artistic reproductions, combining at once high quality and low price.

### 35 CENTS

The clubbing rate of the Farm and Fireside without a premium is THIRTY-FIVE cents, but as a SPECIAL METHOD of introducing these pictures we will give any ONE of them FREE to every one who sends THIRTY-FIVE cents for one year's subscription to the Farm and Fireside, provided the picture is selected when the subscription is sent in.

*(When this offer is accepted no cash commission will be allowed and the name will not be counted in a club)*



No. 785

PHARAOH'S HORSES

Size 20 by 25 inches



No. 796

THE HORSE FAIR

Size 18 by 28 inches



No. 789

DEFIANCE

Size 20 by 25 inches

**CAUTION** We do not want these pictures confounded with the many cheap chromos and colored pictures produced in the last few years. They are of a different class. In monotints, they preserve all the life and beauty of the originals without the inharmonious and gaudy effect of cheap prints.

They Are Artistic,  
Tasty, and  
Worthy a Place in  
the Finest Home

### CHOOSE FROM THE LIST BELOW

IMMACULATE CONCEPTION . . . . .	Painted by Murillo . . . . .	Prem. No. 784
PHARAOH'S HORSES . . . . .	Painted by Herring . . . . .	Prem. No. 785
QUEEN OF FLOWERS . . . . .	Painted by Lefler . . . . .	Prem. No. 786
AFTER WORK . . . . .	Painted by Holmes . . . . .	Prem. No. 787
CHRIST BEFORE PILATE . . . . .	Painted by Munkacsy . . . . .	Prem. No. 788
DEFIANCE, or STAG AT BAY . . . . .	Painted by Landseer . . . . .	Prem. No. 789
KISS ME (Child and Dogs) . . . . .	Painted by Holmes . . . . .	Prem. No. 790
THE LITTLE SHEPHERDESS . . . . .	Painted by Koller . . . . .	Prem. No. 791
PORTRAIT OF WASHINGTON . . . . .	Painted by Stuart . . . . .	Prem. No. 792
THE FINDING OF MOSES . . . . .	Painted by Schopin . . . . .	Prem. No. 793
CAN'T YOU TALK . . . . .	Painted by Holmes . . . . .	Prem. No. 794
WATERFALL BY MOONLIGHT . . . . .	Painted by Rieger . . . . .	Prem. No. 795
THE HORSE FAIR . . . . .	Painted by Bonheur . . . . .	Prem. No. 796

### READ THESE OFFERS

We Will Send the Farm and Fireside the Remainder of the Year and Any One of **25 Cents** These Pictures for

*(When this offer is accepted the club-raiser may have one half the cash commission allowed on a yearly subscription or two of these names may count for one name in a club)*

We Will Send the Farm and Fireside One Year and Any One of These Pictures for **35 Cents**

*(When this offer is accepted no cash commission will be allowed and the name will not be counted in a club)*

We Will Send the Farm and Fireside One Year and Any Two of These Pictures for **50 Cents**

*(When this offer is accepted the club-raiser may have either the regular cash commission or the name may be counted in a club)*

**FREE** Any THREE of these Pictures, Your Choice, Given as a Premium for TWO Yearly Subscriptions to the Farm and Fireside.

The pictures will be sent by mail, securely packed and postage paid. Entire satisfaction guaranteed. A beautiful twelve-page circular giving illustrations and descriptions of the paintings sent FREE on request. Write to-day.

Address FARM AND FIRESIDE, Springfield, Ohio



# 40 Cent Patterns for 10 Cents

We Will Send Any TWO PATTERNS, and This Paper One Year, for 40 CENTS

(When this offer is accepted the club-raiser may have either the regular cash commission or the name may be counted in a club)

These patterns retail in fashion bazaars and stores for twenty-five to forty cents each, but in order to increase the demand for our paper among strangers, and to make it more valuable than ever to our old friends, we offer them to the lady readers of our paper for the low price of only 10 Cents Each. Full descriptions and directions—as the number of yards of material required, the number and names of the different pieces in the pattern, how to cut and fit and put the garment together—are sent with each pattern, with a picture of the garment to go by. These patterns are complete in every particular, there being a separate pattern

for every single piece of the dress. All orders filled promptly. For ladies, give BUST measure in inches. For SKIRT pattern, give WAIST measure in inches. For misses, boys, girls or children, give both BREAST measure in inches and age in years. Order patterns by their numbers. Satisfaction guaranteed or money refunded. To get BUST and BREAST measure, put the tape-measure ALL of the way around the body, over the dress, close under the arms. Special price of each pattern 10 cents. Postage one cent EXTRA on skirt, tea-gown and other heavy patterns.

## FREE We will give any THREE of these patterns for TWO yearly subscriptions to Farm and Fireside FREE

Address FARM AND FIRESIDE, Springfield, Ohio



No. 8010.—CHILD'S FRENCH DRESS. 10 cents. Sizes, 2, 4 and 6 years.



No. 7998.—GIRLS' SHIRT-WAIST 10 cents. Sizes, 6, 8, 10 and 12 years.



No. 7992.—LADIES' FANCY WAIST WITH YOKE. 10c. Sizes, 32, 34, 36, 38 and 40 inches bust.



No. 7873.—MEN'S OUTING-SHIRT. 10 cents. Sizes, 34, 36, 38, 40, 42, 44 and 46 inches breast.



No. 7744.—BOYS' SIZE. 10 cents. Sizes, 10, 12, 14 and 16 years.



No. 7839.—GIRLS' COSTUME. 11 cents. Sizes, 8, 10, 12 and 14 years.



No. 7931.—LADIES' SHIRT-WAIST. 10 cents. Sizes, 32, 34, 36, 38, 40 and 42 inches bust.



No. 8006.—CHILD'S DRESS WITH FANCY YOKE. 10 cents. Sizes, 6 months, 1, 2 and 4 years.

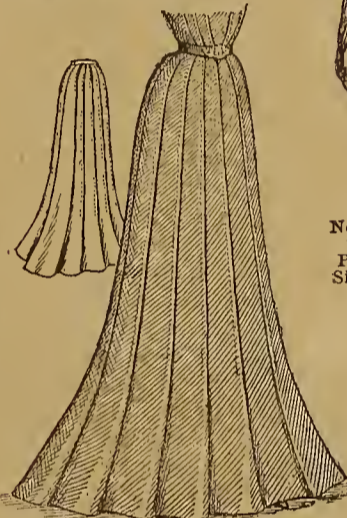

No. 7903.—LADIES' FOUR-PIECE PLAILED SKIRT. 11 cents. Sizes, 22, 24, 26, 28 and 30 inches waist.



No. 7861.—LADIES' SHIRT-WAIST WITH PLAIN OR PLAILED BACK. 10 cents. Sizes, 32, 34, 36, 38, 40 and 42 inches bust.



No. 8009.—LADIES' FANCY SHIRT-WAIST. 10 cents. Sizes, 32, 34, 36, 38, 40 and 42 inches bust.



No. 7922.—BOYS' DRESS. 10 cents. Sizes, 2 and 4 years.

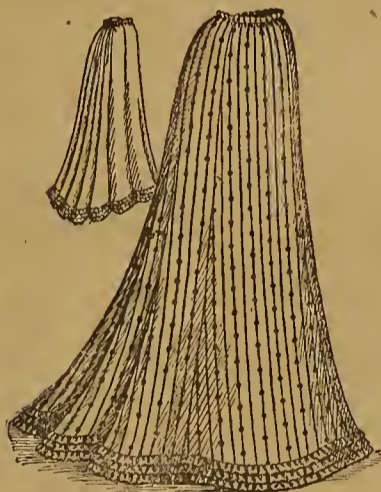

No. 7833.—LADIES' FIVE-GORED MATERNITY-SKIRT. 11 cents. Sizes, 24, 28 and 30 inches waist.



No. 7929.—GIRLS' TUCKED BLOUSE COSTUME. 11 cents. Sizes, 4, 6, 8, 10 and 12 years.



No. 7996.—MISSSES' NIGHTGOWN. 11c. Sizes, 12, 14 and 16 years.



No. 4000.—LADIES' NIGHTGOWN. 11 cents. Sizes, 32, 34, 36, 38, 40, 42 and 44 inches bust.



No. 7781.—LADIES' DRAPED WAIST. 10 cents. Sizes, 32, 34, 36, 38 and 40 inches bust.



No. 7981.—LADIES' TUCKED WAIST WITH YOKE. 10 cents. Sizes, 32, 34, 36, 38 and 40 inches bust.

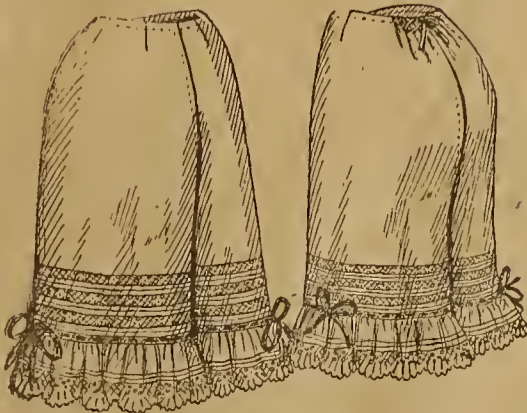

No. 7918.—LADIES' DART-FITTED DRAWERS. 10 cents. Sizes, 22, 24, 26, 28, 30 and 32 inches waist.



No. 7923.—MISSSES' TUCKED WAIST. Sizes, 12, 14 and 16 years. 10 cents. No. 7926.—MISSSES' PLAILED SKIRT. Sizes, 12, 14 and 16 years. 11 cents.

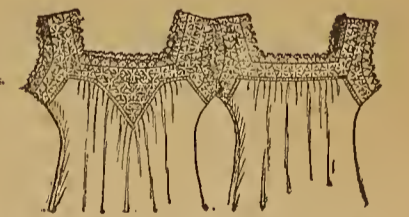

No. 7907.—LADIES' YOKE CHEMISE. 10 cents. Sizes, 32, 34, 36, 38, 40 and 42 inches bust.



No. 7931.—MISSSES' SHIRT-WAIST. 10 cents. Sizes, 12, 14 and 16 years.



## FARM SELECTIONS

### SOME ALFALFA EXPERIENCES

AT THE request of Secretary F. D. Coburn, of the Kansas Department of Agriculture, Mr. H. D. Watson, the gentleman who raises 2,500 acres of alfalfa in the Platte valley, Buffalo county, south-central Nebraska, gives some of his more recent experiences with this plant, printed in the March quarterly report of the Kansas board, entitled "Forage and Fodders." Mr. Watson writes, in part, as follows:

The field sowed to blue-grass and alfalfa in 1884 shows no signs of decay. This field has not been fertilized since seeded, nor disked, as some recommend. The sod formed by the blue-grass sown with the alfalfa prevents much evaporation of the usual moisture, and the blue-grass adds much to the excellence and variety of the pasturage, and obviates all danger of bloat, no animal (sheep or cow) having bloated when pastured in this field. My experience, however, teaches me to advise against pasturing sheep on alfalfa.

\*\*\*

The most satisfactory animal to pasture on alfalfa is the hog. To secure the best results and the largest profits feed the hog while pastured enough of the flesh-forming grains to produce rapid growth, and the spring pig may be marketed in the fall at from two hundred to three hundred pounds weight. If the hog is fed grain during the summer months less time will be required to mature and fatten him. Alfalfa hay should be fed to the hog while fattening. He likes it, and will leave his corn for hay.

My field of blue-grass and alfalfa is cut three times each year when not pastured; the first and second cuttings for hay. The third cutting is saved for seed. The second cutting should be cut not later than July 10th. I have never seen a good seed crop obtained from the first cutting. When the first cutting is saved for seed but little hay is secured from the latter cuttings.

There is a very material difference in the tonnage yield from an equal area of valley and hill land, in favor of the valley land. At best but one crop of hay and one crop of seed can be had from the hill land a year. The texture of the hill land is improved by the deep penetration of the alfalfa roots; they subsoil the land, form a storage reservoir for water, and add much nitrogen to the soil. I shall try blue-grass with alfalfa on the hills this year.

\*\*\*

Wherever there is sufficient moisture to germinate both I would advise sowing alfalfa and blue-grass together, as a larger yield and a better quality of hay are obtained than from alfalfa alone. When sown together I use fifteen pounds of alfalfa and five pounds of blue-grass seed to the acre; of alfalfa alone, twenty pounds an acre is used, sowing ten pounds each way of the field; this insures a uniform stand.

Let me urge the great importance of the most thorough preparation of the soil for seeding. The soil should be made as fine as if for a garden. All moisture should be conserved, and the land seeded the day it is prepared. In this vicinity experience has proved that fall plowing gives the best results; in other sections this may not be true, and each farmer should adopt the plan suited to his locality.

I no longer use a nurse crop in seeding alfalfa. When the weeds shade the ground they are mowed, and are left where they fall. Where the land is very foul the weeds are mowed three times a year, and no hay is saved the first year; but on clean land a fairly good crop of hay has been taken from the second cutting the year of seeding.

Each succeeding year emphasizes the necessity of saving the leaves of this plant. It is stated that eighty-five per cent of the digestible protein is in the leaves. The younger the plant is when cut the more tenaciously the leaves adhere to the stem. After it has wilted, the sooner it is raked into windrows and cocked the larger the percentage of

leaves that will remain on the stem. I cut it when coming into bloom, in the morning, as soon as the dew is off; and as soon as wilted rake it into windrows and cock it, allowing the hay to cure in the cocks.

Stacking in the field has not been satisfactory to me. In this region precipitation is so heavy that a considerable percentage of the hay is damaged in the stacks, particularly that of the first cutting, as this hay, like red clover, is too coarse to prevent the rain soaking the stack. This does not apply to the more arid regions farther west, where, from the commercial standpoint, it is more economical to stack in the field; but in this section, where the rainfall is so great, only as much alfalfa should be grown as the owner can provide suitable covering for, whether it be shed-roofing in the field or mow-room in the barn.

2

### DAIRY AND STOCK NOTES

Stick your nose into that creamery, and sniff! What does it smell like? If it smells like anything except what it is, a creamery, push that nose around some more. Aha! You'll find some dirt! Now, what's that doing there?

Here, you boy! What are you chasing that cow for? Don't you know that your father keeps her for her milk, and that she won't be able to give as much as she should if you race her like that? Mind, now; you let her walk after this!

Make everything on the farm pay for its own keeping. Apply this rule to all your stock—old cows, bulls and dogs, as well as horses; no more that blind sheep than that ancient hog. If the creature pays no profit you don't want it.

Young pigs often have large appetites and poor digestion. Never let them gorge down a quantity of sloppy food. The stomach becomes stretched, the gastric juices diluted; the stomach cannot contract and act upon its contents, and indigestion and scours result.

When testing a herd of cows, some suppose that the average of the individual tests made should be the same as the herd test made by sampling the whole of a day's milking. But this is a mistake. The herd test, or a composite test, may be more or less than such an average, because richer or poorer cows may give more than an average quantity of milk. This would increase or diminish the test, of course.

You are a regular attendant at Sunday meeting, are you? You can stand the two-hour service without a murmur, eh? How about your horse? Is he tied in the sun in summer, or in the wind without a blanket in winter? Say, did you leave him checked up so he couldn't bend his head down without yanking his mouth out of shape? What do you suppose he thinks of your religion?—Farm Journal.

2

### THE QUEEN AND CRESCENT

Route makes low rates to Charleston, S. C., for the great meeting of the National Educational Association July 7th-13th. Write W. C. Rinearson, G.P.A., Cincinnati, for particulars.

2

### ROUGH-GROUND PASTURE

Rough ground may be turned into good pastures for sheep without plowing. If the land is covered with trees it may be scratched over as well as may be by a harrow, so as to get cover for as much grass as possible. The main thing to be done is to start the grass, the sheep will do the rest; and once started the grass will thicken and spread. After the beginning has been made it is easy to improve the grass by scattering seed during a rain, or, indeed, at any time—even in dry weather—as the first rain will start growth, and the treading of the sheep will pack the soil and insure the safety of the young roots. The best grasses for a sheep-pasture are those with creeping roots, as the common red-top, the blue-grasses, orchard-grass and tall meadow oat-grass, while clover is one of the most valuable of this family of pasture-plants. The quantity of seed to be sown is twenty pounds of each of the grasses and ten pounds of the white clover to the acre, or the equivalent.—American Sheep-Breeder.

- ARMSTRONG & McKELVY Pittsburgh.
- BEYMER-BAUMAN Pittsburgh.
- DAVIS-CHAMBERS Pittsburgh.
- FAHNESTOCK Pittsburgh.
- ANCHOR Cincinnati.
- ECKSTEIN Cincinnati.
- ATLANTIC New York.
- BRADLEY New York.
- BROOKLYN New York.
- JEWETT New York.
- ULSTER New York.
- UNION New York.
- SOUTHERN Chicago.
- SHIPMAN Chicago.
- COLLIER Chicago.
- MISSOURI St. Louis.
- RED SEAL St. Louis.
- SOUTHERN St. Louis.
- JOHN T. LEWIS & BROS CO Philadelphia.
- MORLEY Cleveland.
- SALEM Salem, Mass.
- CORNELL Buffalo.
- KENTUCKY Louisville.

IT IS quite generally believed, particularly by large consumers and practical painters, that Pure White Lead is the best paint. It is because of this belief that manufacturers of the so-called White Leads, mixtures of Whiting, Barytes and Zinc, brand them "White Lead," "Pure White Lead," etc., etc. You can avoid these by making sure that the brand is right.

**FREE** For colors use National Lead Company's Pure White Lead Tinting Colors. Any shade desired is readily obtained. Pamphlet giving full information and showing samples of Colors, also pamphlet entitled "Uncle Sam's Experience With Paints" forwarded upon application.

National Lead Co., 100 William Street, New York.

## BUCKEYE FERTILIZER HOE DRILL

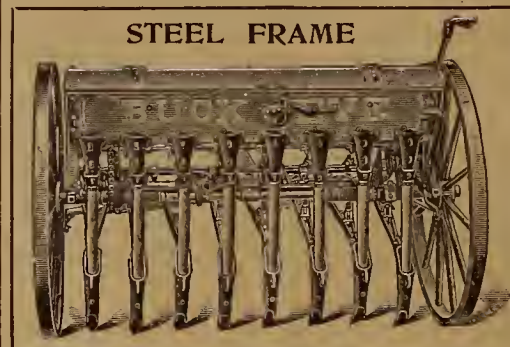

is a patented feature and used exclusively on the BUCKEYE. Sows all kinds of fertilizer evenly and successfully. Send for complete drill circular.

Address P. P. MAST & CO., No. 17 Canal Street, Springfield, Ohio, or Philadelphia, Pa.

THE Buckeye Combined Grain and Fertilizer Drill, as shown in the illustration, is without doubt the most perfect grain and fertilizer drill made. Has our Change of Speed Device and our Double-Run Force Feed, which sows wheat, corn, oats, peas, beans, beet-seed, cow-peas, etc., with uniform accuracy. Also our Glass Fertilizer Feed. The employment of glass in the construction of a fertilizer feed makes it possible to obviate the corroding of the mechanism and doing away with the annoyance commonly found in other fertilizer drills. This

### PROFIT FOR MAKER ONLY

We manufacture 178 styles of vehicles and 65 styles of harness and sell them to you direct from our factory at wholesale prices. In fact, we are the largest manufacturers of vehicles and harness in the world selling to the consumer exclusively. When you buy on this plan you pay only the profit of the manufacturer. No traveling expenses, no losses, no agent's commission and no dealer's profits.

**WE HAVE NO AGENTS** preferring to deal with you direct. We have followed this plan for 27 years. No matter where you live, we can reach you and save you money. We ship our vehicles and harness anywhere for examination and guarantee safe arrival. We manufacture everything we sell, and we can assure you of good quality from beginning to end; good wood work, good iron and steel, good paint and varnish, good finish, good trimmings, fine style and the largest selection in the land. Large illustrated catalogue—FREE.

**ELKHART CARRIAGE & HARNESS MANUFACTURING CO., Elkhart, Ind.**



# FREE

## YEARS TRIAL

## PIANO \$155.00 UP

Money back with interest if not satisfied with your bargain. Write today for our latest catalogue. It is free. It shows you the latest and most up-to-date Organs and Pianos on the market. It tells you all about our patent combination actions and orchestral attachments which imitate a great variety of stringed instruments. Something new and novel that never fails to please. A discount of \$10.00 on every Organ and \$20.00 on every Piano if you get our catalogue now. We sell for cash or on easy payments. No money in advance required. From factory to home. No agents. No middlemen's profits. Write today.

**BEETHOVEN PIANO & ORGAN CO.**  
Box 628  
Washington, N.J.

No. 3034 Buggy. Price \$38.30 with leather quarter top.

# Deal with the Makers

When you buy a carriage, buggy or harness. Choose from the biggest stock and fullest assortment, and pay only the cost of making, with but one moderate profit added. Our plan of selling direct from the factory insures satisfaction—your money back if you're dissatisfied with your purchase—and enables you to **save the dealer's profit.**

Our complete illustrated catalogue, showing many styles of high grade vehicles, harness, robes, blankets and horse equipments, with detailed descriptions of each, mailed free. Write for it and learn how cheaply you can buy when the jobber's and dealer's profits are cut off.

**THE COLUMBUS CARRIAGE & HARNESS CO., P. O. Box 772, Columbus, O.**

# WANT A WATCH?

You can secure a valuable watch absolutely free. Send us your name and address and we will send you by return mail your endless-chain ticket and ten tickets which you are to sell to your friends for 15 cents each, remit the \$1.50 to us, with the names and addresses to whom you sold, and we will send them a supply of tickets like those sent you. When your chain is completed usually 2 to 3 weeks; we will send a watch of your own selection FREE. Watches guaranteed value \$15. No lottery. Square dealing guaranteed. Address

**BOYLSTON & BENT, Rochester, N. H.**

### The Most Cider

of the BEST QUALITY and the PUREST form can be secured from a given quantity of apples by the use of the

## HYDRAULIC CIDER PRESS

The only press awarded medal and diploma at World's Fair. Get our free illustrated catalogue before buying.

**HYDRAULIC PRESS MFG. CO.,**  
6 Main St., Mt. Ghent, Ohio.

### SAVE YOUR CASH

You need fence. The ready made kinds cost from 60 to 75c. a rod. We tell you how to make the best fence on earth for

## 20 to 35 Cents per Rod.

Over 100 Styles, and from 50 to 70 rods per day. Send for our free Catalogue.

**KITSELMAN BROTHERS,**  
Box 278  
Hidgeville, Indiana, U. S. A.