



Class TJ230

Book B48

Copyright N^o _____

COPYRIGHT DEPOSIT.

Benjamin's Machine Design.

By CHARLES H. BENJAMIN, Professor
in the Case School of Science.

Hoskins' Hydraulics.

By L. M. HOSKINS, Professor in Leland
Stanford University.

**Adams' Alternating-current
Machines.**

By C. A. ADAMS, Professor in Harvard
University. [*In preparation.*]

HENRY HOLT AND COMPANY
NEW YORK CHICAGO

MACHINE DESIGN

BY

CHARLES H. BENJAMIN

*Professor of Mechanical Engineering in the
Case School of Applied Science*



NEW YORK

HENRY HOLT AND COMPANY

1906

TJ230
B48
1906

LIBRARY of CONGRESS
Two Copies Received
DEC 1 1906
Copyright Entry
Nov. 30, 1906
CLASS A XXc., No.
161848.
COPY B.

Copyright, 1906

BY

HENRY HOLT AND COMPANY

6-45053

PREFACE.

THIS book embodies to a considerable extent the writer's experience in teaching and in commercial work. While the underlying mechanical principles of machine design are permanent, the application of them is continually changing. The researches of the experimenter and the practice of the builder are always showing good reasons for the modification of design.

Although the present work was prepared primarily for a text-book, it contains mainly what the writer has found necessary in his own practice as an engineer. As far as possible the formulas for the strength and stiffness of machine details have been fortified by the results of experiments or by the practical experience of manufacturers.

Attention is called particularly to the experiments on cast-iron cylinders, pipe fittings, helical springs, roller bearings, gear teeth, pulley arms, and the bursting strength of fly-wheels.

What the student needs to learn before graduation is also what he needs to remember after, and it is hoped that this book contains the necessary facts and principles and not too much else.

C. H. B.

TABLE OF CONTENTS.

CHAPTER.	PAGE.
I. UNITS AND TABLES.....	1
1. Units. 2. Abbreviations. 3. Materials. 4. Notation. 5. Formulas. 6. Profiles of uniform strength. 7. Factors of safety.	
II. FRAME DESIGN.....	15
8. General principles of design. 9. Machine supports. 10. Machine frames.	
III. CYLINDERS AND PIPES.....	25
11. Thin shells. 12. Thick shells. 13. Steel and wrought iron pipe. 14. Strength of boiler tubes. 15. Pipe fittings. 16. Steam cylinders. 17. Thickness of flat plates.	
IV. FASTENINGS.....	54
18. Bolts and nuts. 19. Machine screws. 20. Eye bolts and hooks. 21. Riveted joints. 22. Lap joints. 23. Butt joints with two straps. 24. Efficiency of joints. 25. Butt joints with unequal straps. 26. Practical rules. 27. Riv- eted joints for narrow plates. 28. Joint pins. 29. Cotter.	
V. SPRINGS.....	73
30. Helical springs. 31. Square wire. 32. Experiments. 33. Springs in torsion. 34. Flat springs. 35. Elliptic and semi-elliptic springs.	
VI. SLIDING BEARINGS.....	86
36. Slides in general. 37. Angular slides. 38. Gibbed slides. 39. Flat slides. 40. Circular guides. 41. Stuffing boxes.	
VII. JOURNALS, PIVOTS AND BEARINGS.....	96
42. Journals. 43. Adjustment. 44. Lubrication. 45. Fric- tion of journals. 46. Limits of pressure. 47. Heating of journals. 48. Experiments. 49. Strength and stiffness of journals. 50. Caps and bolts. 51. Step bearings. 52. Friction of pivots. 53. Flat collar. 54. Conical pivot. 55. Schiele's pivot. 56. Multiple bearing.	

CHAPTER.	PAGE.
VIII. BALL AND ROLLER BEARINGS.....	118
57. General principles. 58. Journal bearings. 59. Step bearings. 60. Materials and wear. 61. Design of bearings. 62. Roller bearings. 63. Grant roller bearing. 64. Hyatt rollers. 65. Roller step bearings.	
IX. SHAFTING, COUPLINGS AND HANGERS.....	130
66. Strength of shafting. 67. Couplings. 68. Clutches. 69. Coupling bolts. 70. Shafting keys. 71. Hangers and boxes.	
X. GEARS, PULLEYS AND CRANKS.....	146
72. Gear teeth. 73. Strength of teeth. 74. Lewis' formula. 75. Experimental data. 76. Teeth of bevel gears. 77. Rim and arms. 78. Sprocket wheels and chains, 79. Silent chains. 80. Cranks and levers.	
XI. FLY-WHEELS.....	166
81. In general. 82. Safe speed for wheels. 83. Experiments on fly wheels. 84. Wooden pulleys. 85. Rims of cast-iron gears. 86. Rotating discs. 87. Plain discs. 88. Conical discs. 89. Discs with logarithmic profile. 90. Bursting speeds.	
XII. TRANSMISSION BY BELTS AND ROPES.....	184
91. Friction of belting. 92. Strength of belting. 93. Taylor's experiments. 94. Rules for width of belts. 95. Speed of belting. 96. Manila rope transmission. 97. Strength of Manila ropes. 98. Wire rope transmission.	

TABLES.

	PAGE.
I. STRENGTH OF WROUGHT METALS	6
II. STRENGTH OF CAST METALS	7
III. VALUES OF Q IN COLUMN FORMULA	10
IIIa. VALUES OF S AND K IN COLUMN FORMULA	10
IV. CONSTANTS OF CROSS-SECTION	11
V. FORMULAS FOR LOADED BEAMS	12
VI. SIZES OF IRON AND STEEL PIPE	31
VII. SIZES OF EXTRA STRONG PIPE	33
VIII. SIZES OF DOUBLE EXTRA STRONG PIPE	34
IX. SIZES OF IRON AND STEEL BOILER TUBES	36
X. STRENGTH OF STANDARD SCREWED PIPE FITTINGS	41
XI. BURSTING STRENGTH OF CAST IRON CYLINDERS	45
XII. STRENGTH OF REINFORCED CYLINDERS	47
XIII. STRENGTH OF CAST IRON PLATES	52
XIV. STRENGTH OF IRON OR STEEL BOLTS	54
XV. DIMENSIONS OF MACHINE SCREWS	57
XVI. DIMENSIONS OF RIVETED LAP JOINTS	65
XVII. DIMENSIONS OF RIVETED BUTT JOINTS	65
XVIII. STRENGTH AND STIFFNESS OF HELICAL SPRINGS	77
XIX. FRICTION OF PISTON ROD PACKINGS	93
XX. " " " " "	94
XXI. " " " " "	94
XXII. FRICTION OF JOURNAL BEARING	108
XXIII. FRICTION OF ROLLER AND PLAIN BEARINGS	126
XXIV. " " " " " "	127
XXV. DIAMETERS OF SHAFTING	132
XXVI. PROPORTIONS OF GEAR TEETH	148
XXVII. SIZES OF TEST FLY-WHEELS	172
XXVIII. FLANGES AND BOLTS OF TEST FLY-WHEELS	172
XXIX. FAILURE OF FLANGED JOINTS	173
XXX. SIZES OF LINKED JOINTS	173
XXXI. FAILURE OF LINKED JOINTS	174
XXXII. BURSTING SPEEDS OF ROTATING DISCS	182
XXXIII. HORSE POWER OF MANILA ROPE	192
XXXIV. HORSE POWER OF WIRE ROPE	194

MACHINE DESIGN.

CHAPTER I.

UNITS AND TABLES.

1. Units. In this book the following units will be used unless otherwise stated.

Dimensions in inches.

Forces in pounds.

Stresses in pounds per square inch.

Velocities in feet per second.

Work and energy in foot pounds.

Moments in pounds inches.

Speeds of rotation in revolutions per minute.

The word *stress* will be used to denote the resistance of material to distortion per unit of sectional area. The word *deformation* will be used to denote the distortion of a piece per unit of length. The word *set* will be used to denote total permanent distortion of a piece.

In making calculations the use of the slide-rule and of four-place logarithms is recommended ; accuracy is expected only to three significant figures.

2. Abbreviations. The following abbreviations are among those recommended by a committee of the American Society of Mechanical Engineers in December, 1904, and will be used throughout the book,

NAME.	ABBREVIATION.
Inches	in.
Feet	ft.
Yards	yd.
Miles	spell out.
Pounds	lb.
Tons	spell out.
Gallons	gal.
Seconds	sec.
Minutes	min.
Hours	hr.
Linear	lin.
Square	sq.
Cubic	cu.
Per	spell out.
Fahrenheit	fahr.
Percentage	% or per cent.
Brake horse power	b.h.p.
Electric horse power	e.h.p.
Indicated horse power	i.h.p.
British thermal units	B.t.u.
Diameter	Diam.

3. Materials. The principal materials used in machine construction are given in the following tables with the physical characteristics of each.

By *wrought iron* is meant commercially pure iron which has been made from molten pig-iron by the puddling process and then squeezed and rolled, thus developing the fiber. This iron has been largely supplanted by soft steel.

Ordinary wrought iron contains from 0.1% to 0.3% of carbon. Soft steel may contain no more than this, but is different in structure. The particles of iron in the puddling process are more or less enveloped in slag or earthy matter and as the bloom is squeezed and

rolled the particles become fibers separated from each other by a thin sheath or covering of slag, and it is this that gives such iron its characteristic structure. The principal impurities in the iron are phosphorus from the ore and sulphur from the fuel.

In making *steel*, on the other hand, the molten iron has had the silicon and carbon removed by a hot blast, either passing through the liquid as in the Bessemer converter, or over its surface as in the open-hearth furnace. A suitable quantity of carbon and manganese has then been added and the metal poured into ingot molds. If the steel is then reheated and passed through a series of rolls, structural steel and rods or rails result.

Bessemer steel contains from 0.1% to 0.6% of carbon and has a fine granular structure. This material has been much used for rails.

Open hearth steel differs from Bessemer but little in its chemical composition but is usually more reliable in quality on account of the more deliberate nature of the process of manufacture. It is generally used for boiler plate and for steel castings. Two grades of boiler plate are commonly known as marine steel and flange steel, the latter being of the better quality.

Steel castings are poured directly from the open hearth furnace and allowed to cool without any drawing or rolling. They are coarser and more crystalline than the rolled steel.

Crucible steel usually contains from one to one and a half per cent of carbon, is relatively high priced and only used for cutting tools. It is made by melting steel in an air-tight crucible with the proper additions of carbon and manganese.

Cast iron is made directly from the pig by remelt-

ing and casting, is granular in texture and contains from two to five per cent. of carbon. A portion of the carbon is chemically combined with the iron while the remainder exists in the form of graphite. The harder and whiter the iron the more carbon is found chemically combined. Silicon is an important element in cast iron and influences the rate of cooling. The more slowly iron cools after melting the more graphite forms and the softer the iron.

Two per cent of silicon gives a soft gray iron of a high tensile strength.

Machinery iron contains usually from one and one half to two per cent of silicon.

Malleable iron is cast iron annealed and partially decarbonized by being heated in an annealing oven in contact with some oxidizing material such as hæmatite ore. This process makes the iron tougher and less brittle.

All castings including those made from alloys are somewhat unreliable on account of hidden flaws and of the strains developed by shrinkage while cooling.

The so-called *high-speed* or *air-hardening tool steels* are alloys of steel with various substances such as chromium (chrome steel), tungsten (Mushet steel), molybdenum, etc., etc.

They are characterized by extreme hardness at comparatively high temperatures. Their other physical characteristics are not of particular interest.

The addition of nickel to steel increases its ultimate strength and also raises its elastic limit. The tensile strength is sometimes as high as 200,000 lb. per sq. in. and the steel is also tough and well adapted to resist shocks.

The *bronzes* are alloys of copper and tin, copper and zinc, or of all three. The copper-tin alloys usually contain 85 or 90 per cent of copper and are expensive.

The copper-zinc alloys, or *brasses* as they are sometimes called, should have from 60 to 70 per cent of copper for maximum strength and ductility.

Bronzes high in tin and low in copper are weak, but have considerable ductility and make good metals for bearings. Tin 80, copper 10 and antimony 10 is Babbitt metal, so much used to line journal bearings, the antimony increasing the hardness.

The late Dr. Thurston's experiments on the copper-tin-zinc alloys showed a maximum strength for copper 55, zinc 43 and tin 2 per cent. The tensile strength of this mixture was nearly 70,000 lb. per sq. in.

Phosphor bronze is a copper alloy with a small amount of phosphorus added to prevent oxidation of the copper and thereby strengthen the alloy.

Manganese bronze is an alloy of copper and manganese, usually containing iron and sometimes tin. A bronze containing about 84 per cent copper, 14 per cent manganese and a little iron, has much the same physical characteristics as soft steel and resists corrosion much better.

The constants for strength and elasticity given in the tables are only fair average values, and should be determined for any special material by direct experiment when it is practicable. Many of the constants are not given in the table on account of the lack of reliable data for their determination.

The strength of steel, either rolled or cast, depends so much upon the percentages of carbon, phosphorus and manganese, that any general figures are liable to be misleading. Structural steel usually has a tensile strength of about 65,000 lb. per sq. in., while boiler plate usually has less carbon, a low tensile strength and good ductility.

TABLE I.
WROUGHT METALS.

Kind of Metal.	Wt. of Cu. inch.	Wt. of Cu. Ft.	Ultimate Strength.			Elastic Limit. Tens'n.	Modulus of Rupture Tr'nsv'rse.	Modulus of Elasticity. Tension.
			Tens'n.	Shear.				
				Compress.	Compress.			
Wrought Iron, small bars.....	.28	485	55000	38000	45000	28000	40000	26000000
Wrought Iron, plates.....			50000		40000	25000		25000000
Wrought Iron, large forgings.....			45000		35000	22500	30000	25000000
Structural Steel.....			64000	64000	50000	33000	60000	29000000
Steel, flange plate.....			58000	100000	48000	34000		28000000
Steel, marine plate.....			52000			30000		24000000
Soft Steel, 0.15 C.....			65000		50000	35000		28000000
Machinery Steel.....			80000		65000	45000		30000000
Steel, Crucible or Tool.....	.282	487	120000			60000		40000000

Prof. Thurston gives the following formula for the tensile strength of steel when C is the per cent of carbon: $S=60000+70000C$.

TABLE II.
CAST METALS.

Kind of Metal.	Wt. of Cu. Inch.	Wt. of Cu. Ft.	Ultimate strength.			Elastic Limit. Tensi'n.	Modulus of Rupture Transv'se.	Modulus of Elasticity. Tension.
			Tensi'n.	Compress.	Shear.			
Cast Iron.....	.26	450	18000	75000	25000	12000	36000	18000000
Malleable Castings.....	.256	442	36000	42000	16000
Steel Castings (small).....	38000	125000	18000	30000000
Steel Castings (large).....	70000	70000	60000	40000	70000	30000000
Brass castings.....	.289	500	18000	12000	16000	9000000
Copper Castings.....	.321	555	24000	75000	24000	30000	15000000
Bronze, Gun Metal.....	.309	534	36000	100000	10000000
Bronze, 10Al. 90 Cu.....	85000	132000
Bronze, Manganese.....	60000	120000	30000
Bronze, Phosphor.....	58000	43000	20000	14000000
Aluminum Castings.....	.092	159	28000	13000	14000	11000000
Aluminum Wire.....	42000

The results in Table II are mostly calculated from experiments by the author.

4. Notation.

Arc of contact	= θ radians.
Area of section	= A sq. in.
Breadth of section	= b in.
Coefficient of friction	= f
Deflection of beam	= Δ in.
Depth of section	= h in.
Diameter of circular section	= d in.
Distance of neutral axis from outer fiber	= y in.
Elasticity, modulus of,	
in tension and compression	= E
in shearing and torsion	= G
Heaviness, weight per cu. ft.	= w
Length of any member	= l in.
Load or dead weight	= W lb.
Moment, in bending	= M lb.-in.
in twisting	= T lb.-in.
Moment of inertia	
rectangular	= I
polar	= J
Pitch of teeth, rivets, etc.	= p in.
Radius of gyration	= r in.
Section modulus, bending	= $\frac{I}{y}$
twisting	= $\frac{J}{y}$
Stress per unit of area	= S
Velocity	= v ft per sec.

5. Formulas.

· *Simple Stress.*

$$\text{Tension, compression or shear, } S = \frac{W}{A} \dots \dots (1)$$

Bending under Transverse Load.

General equation, $M = \frac{SI}{y} \dots \dots \dots (2)$

Rectangular section, $M = \frac{Sbh^2}{6} \dots \dots \dots (3)$

Rectangular section, $bh^2 = \frac{6M}{S} \dots \dots \dots (4)$

Circular section, $M = \frac{Sd^3}{10.2} \dots \dots \dots (5)$

Circular section, $d = \sqrt[3]{\frac{10.2 M}{S}} \dots \dots \dots (6)$

Torsion or Twisting.

General equation, $T = \frac{SJ}{y} \dots \dots \dots (7)$

Circular section, $T = \frac{Sd^3}{5.1} \dots \dots \dots (8)$

Circular section, $d = \sqrt[3]{\frac{5.1 T}{S}} \dots \dots \dots (9)$

Hollow circular section, $T = \frac{S}{5.1} \frac{d^4 - d_1^4}{d} \dots \dots \dots (10)$

Other values of $\frac{I}{y}$ and $\frac{J}{y}$ may be taken from Table 4.

Combined Bending and Twisting.

Calculate shaft for a twisting moment,

$$T^1 = M + \sqrt{M^2 + T^2} \dots \dots \dots (11)$$

Column subject to Bending.

Use Rankine's formula, $\frac{W}{A} = \frac{S}{1 + q \frac{l^2}{r^2}} \dots \dots \dots (12)$

The values of r^2 may be taken from Table IV. The subjoined table gives the average values of q , while S is the compressive strength of the material.

TABLE III.
VALUES OF q IN FORMULA 12.

Material.	Both ends fixed.	Fixed and round.	Both ends round.	Fixed and free.
Timber	$\frac{1}{3000}$	$\frac{1.78}{3000}$	$\frac{4}{3000}$	$\frac{16}{3000}$
Cast Iron.....	$\frac{1}{5000}$	$\frac{1.78}{5000}$	$\frac{4}{5000}$	$\frac{16}{5000}$
Wrought Iron... ..	$\frac{1}{36000}$	$\frac{1.78}{36000}$	$\frac{4}{36000}$	$\frac{16}{36000}$
Steel.....	$\frac{1}{25000}$	$\frac{1.78}{25000}$	$\frac{4}{25000}$	$\frac{16}{25000}$

Carnegie's hand-book gives $S=50000$ for medium steel columns and $q=\frac{1}{360000}$, $\frac{1}{240000}$ and $\frac{1}{180000}$ for the three first columns in above table.

In this formula, as in all such, the values of the constant should be determined for the material used by direct experiment if possible.

Or use straight line formula, $\frac{W}{A} = S - k\frac{l}{r}$. . . (12a)

TABLE IIIa.
VALUES OF S AND k IN FORMULA (12a).
(Merriman's Mechanics of Materials.)

Kind of Column.	S	k	Limit $\frac{l}{r}$
Wrought Iron :			
Flat ends.....	42000	128	218
Hinged ends.....	42000	157	178
Round ends.....	42000	203	138
Mild Steel :			
Flat ends.....	52500	179	195
Hinged ends.....	52500	220	159
Round ends.....	52500	284	123
Cast Iron :			
Flat ends.....	80000	438	122
Hinged ends.....	80000	537	99
Round ends.....	80000	693	77
Oak :			
Flat ends.....	5400	28	128

Carnegie's hand-book gives allowable stress for structural columns of mild steel as 12000 for lengths less than 90 radii, and as $17100 - 57 \frac{l}{r}$ for longer columns.

This allows a factor of safety of about four.

TABLE IV.
CONSTANTS OF CROSS-SECTION.

Form of Section and Area A .	Square of Radius of Gyration r^2	Moment of Inertia $I = Ar^2$	Section Modulus $\frac{I}{y}$	Polar Moment of Inertia J	Torsion Modulus $\frac{J}{y}$
Rectangle bh	$\frac{h^2}{12}$	$\frac{bh^3}{12}$	$\frac{bh^2}{6}$	$\frac{bh^3 + b^3h}{12}$	$\frac{bh^3 + b^3h}{6 \sqrt{b^2 + h^2}}$
Square d^2	$\frac{d^2}{12}$	$\frac{d^4}{12}$	$\frac{d^3}{6}$	$\frac{d^4}{6}$	$\frac{d^3}{4.24}$
Hollow Rectangle or I-beam $bh - b_1h_1$	$\frac{bh^3 - b_1h_1^3}{12(bh - b_1h_1)}$	$\frac{bh^3 - b_1h_1^3}{12}$	$\frac{bh^3 - b_1h_1^3}{6h}$		
Circle $\frac{\pi}{4}d^2$	$\frac{d^2}{16}$	$\frac{\pi d^4}{64}$	$\frac{d^3}{10.2}$	$\frac{\pi d^4}{32}$	$\frac{d^3}{5.1}$
Hollow Circle $\frac{\pi}{4}(d^2 - d_1^2)$	$\frac{d^2 + d_1^2}{16}$	$\frac{\pi(d^4 - d_1^4)}{64}$	$\frac{d^4 - d_1^4}{10.2d}$	$\frac{\pi(d^4 - d_1^4)}{32}$	$\frac{d^4 - d_1^4}{5.1d}$
Ellipse $\frac{\pi}{4}ab$	$\frac{a^2}{16}$	$\frac{\pi ba^3}{64}$	$\frac{ba^2}{10.2}$	$\frac{\pi(ba^3 + ab^3)}{64}$	$\frac{ba^3 + ab^3}{10.2a}$

Values of I and J for more complicated sections can be worked out from those in table.

TABLE V.
FORMULAS FOR LOADED BEAMS.

Beams of Uniform Cross-section.	Maximum. Moment. M	Maximum. Deflection. Δ
Cantilever, load at end.....	Wl	$\frac{Wl^3}{3EI}$
Cantilever, uniform load.....	$\frac{Wl}{2}$	$\frac{Wl^3}{8EI}$
Simple beam, load at middle.....	$\frac{Wl}{4}$	$\frac{Wl^3}{48EI}$
Simple beam, uniform load.....	$\frac{Wl}{8}$	$\frac{5Wl^3}{384EI}$
Beam fixed at one end, supported at other, load at middle.....	$\frac{3Wl}{16}$	$\frac{.0182Wl^3}{EI}$
Beam fixed at one end, supported at other, uniform load.....	$\frac{Wl}{8}$	$\frac{.0054Wl^3}{EI}$
Beam fixed at both ends, load at middle..	$\frac{Wl}{8}$	$\frac{Wl^3}{192EI}$
Beam fixed at both ends, uniform load....	$\frac{Wl}{12}$	$\frac{Wl^3}{384EI}$
Beam fixed at both ends, load at one end, (pulley arm).....	$\frac{Wl}{2}$	$\frac{Wl^3}{12EI}$

6. Profiles of Uniform Strength. In a bracket or beam of uniform cross-section the stress on the outer row of fibers increases as the bending moment increases and the piece is most liable to break at the point where the moment is a maximum. This difficulty can be remedied by varying the cross-section in such a way as to keep the fiber stress constant along the top or bottom of the piece. The following table shows the shapes to be used under different conditions.

Type.	Load.	Plan.	Elevation.
Cantilever..	Center	Rectangle..	Parabola, axis horizontal.
Cantilever..	Uniform ...	Rectangle..	Triangle.
Simp. Beam	Center	Rectangle..	Two parabolas intersecting under load.
Simp. Beam	Uniform ...	Rectangle..	Ellipse, major axis horizontal.

The material is best economized by maintaining a constant breadth and varying the depth as indicated.

This method of design is applicable to cast pieces rather than to those that are forged or cut.

The maximum deflection of cantilevers and beams having a profile of uniform strength is greater than when the cross-section is uniform, fifty per cent. greater if the breadth varies, and one hundred per cent greater if the depth varies.

7. Factors of Safety. A factor of safety is the ratio of the ultimate strength of any member to the ordinary working load which will come upon it. This factor is intended to allow for : (a) Overloading either intentional or accidental. (b) Sudden blows or shocks. (c) Gradual fatigue or deterioration of material. (d) Flaws or imperfections in the material.

To a certain extent the term "factor of ignorance" is justifiable since allowance is made for the unknown. Certain fixed laws may guide one, however, in making the selection of a factor. It is a well-known fact that loads in excess of the elastic limit are liable to cause failure in time. Therefore, when the elastic limit of the material can be determined, it should be used as a basis rather than to use the ultimate strength.

Furthermore, suddenly applied loads will cause about double the stress due to dead loads. These two considerations point to four as the least factor that should be used when the ultimate strength is taken as a basis. Pieces subject to stress alternately in opposite directions should have large factors of safety.

The following table shows the factors used in good practice under various conditions :

Structural steel in buildings	.	.	4
“ “ “ “ bridges	.	.	5
Steel in machine construction	.	.	6
“ “ engine “	.	.	10
Steel plate in boilers	.	.	5
Cast iron in machines	.	.	6 to 15

Castings of bronze or steel should have larger factors than rolled or forged metal on account of the possibility of flaws.

Cast iron should not be used in pieces subject to tension or bending if there is a liability of shocks or blows coming on the piece.

CHAPTER II.

FRAME DESIGN.

8. General Principles of Design. The working or moving parts should be designed first and the frame adapted to them.

The moving parts can be first arranged to give the motions and velocities desired, special attention being paid to compactness and to the convenience of the operator.

Novel and complicated mechanisms should be avoided and the more simple and well tried devices used.

Any device which is new should be first tried in a working model before being introduced in the design.

The dimensions of the working parts for strength and stiffness must next be determined and the design for the frame completed. This may involve some modification of the moving parts.

In designing any part of the machine, the metal must be put in the line of stress and bending avoided as far as possible.

Straight lines should be used for the outlines of pieces exposed to tension or compression, circular cross sections for all parts in torsion, and profile of uniform fiber stress for pieces subjected to bending action.

Superfluous metal must be avoided and this excludes all ornamentation as such. There should be a good

practical reason for every pound of metal in the machine.

An excess of metal is sometimes needed to give inertia and solidity and prevent vibration, as in the frames of machines having reciprocating parts, like engines, planers, slotting machines, etc.

Mr. Oberlin Smith has characterized this as the "anvil" style of design in contradistinction to the "fiddle" style.

In one the designer relies on the mass of the metal, in the other on the distribution of the metal, to resist the applied forces.

A comparison of the massive Tangye bed of some large high-speed engines with the comparatively slight girder frame used in most Corliss engines, will emphasize this difference.

It may be sometimes necessary to waste metal in order to save labor in finishing, and in general the aim should be to economize labor rather than stock.

The designers should be familiar with all the shop processes as well as the principles of strength and stability. The usual tendency in design, especially of cast iron work, is towards unnecessary weight.

All corners should be rounded for the comfort and convenience of the operator, no cracks or sharp internal angles left where dirt and grease may accumulate, and in general special attention should be paid to so designing the machine that it may be safely and conveniently operated, that it may be easily kept clean, and that oil holes are readily accessible. The appearance of a machine in use is a key to its working condition.

Polished metal should be avoided on account of its tendency to rust, and neither varnish nor bright colors

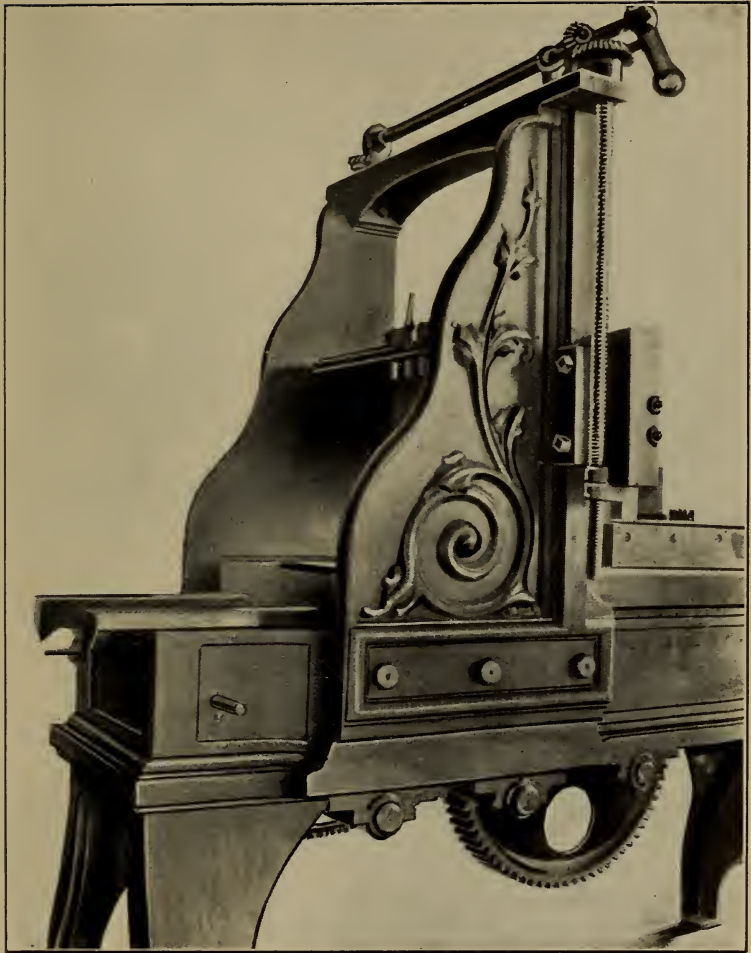

FIG. 1. OLD PLANING MACHINE. AN EXAMPLE OF ELABORATE ORNAMENTATION.

tolerated. The paint should be of some neutral tint and have a dead finish so as not to show scratches or dirt.

Beauty is an element of machine design, but it can only be attained by legitimate means which are appropriate to the material and the surroundings.

Beauty is a natural result of correct mechanical construction but should never be made the object of design.

Harmony of design may be secured by adopting one type of cross-section and adhering to it throughout, never combining cored or box sections with ribbed sections. In cast pieces the thickness of metal should be uniform to avoid cooling strains, and for the same reason sharp corners should be absent. The lines of crystallization in castings are normal to the cooled surface and where two flat pieces come together at right angles, the interference of the two sets of crystals forms a plane of weakness at the corner. This is best obviated by joining the two planes with a bend or sweep.

Rounding the external corner and filleting the internal one is usually sufficient. Where two parts come together in such a way as to cause an increase of thickness of the metal there are apt to be "blow holes" or "hot spots" at the junction due to the uneven cooling.

"Strengthening" flanges when of improper proportions or in the wrong location are frequently a source of weakness rather than strength. A cast rib or flange on the tension side of a plate exposed to bending, will sometimes cause rupture by cracking on the outer edge. When apertures are cut in a frame either for core-prints or for lightness, the hole or aperture should be

the symmetrical figure, and not the metal that surrounds it, to make the design pleasing to the eye.

The design should be in harmony with the material used and not imitation. For example, to imitate structural work either of wood or iron in a cast-iron frame is silly and meaningless.

Machine design has been a process of evolution. The earlier types of machines were built before the general introduction of cast-iron frames and had frames made of wood or stone, paneled, carved and decorated as in cabinet or architectural designs.

When cast iron frames and supports were first introduced they were made to imitate wood and stone construction, so that in the earlier forms we find panels, moldings, gothic traceries and elaborate decorations of vines, fruit and flowers, the whole covered with contrasting colors of paint and varnished as carefully as a piece of furniture for the drawing-room. Relics of this transition period in machine architecture may be seen in almost every shop. One man has gone down to posterity as actually advertising an upright drill designed in pure Tuscan.

9. Machine Supports. The fewer the number of supports the better. Heavy frames, as of large engines, lathes, planers, etc., are best made so as to rest directly on a masonry foundation. Short frames as those of shapers, screw machines and milling machines, should have one support of the cabinet form. The use of a cabinet at one end and legs at the other is offensive to the eye, being inharmonious. If two cabinets are used provision should be made for a cradle or pivot at one end to prevent twisting of the frame by an uneven foundation. The use of intermediate supports is

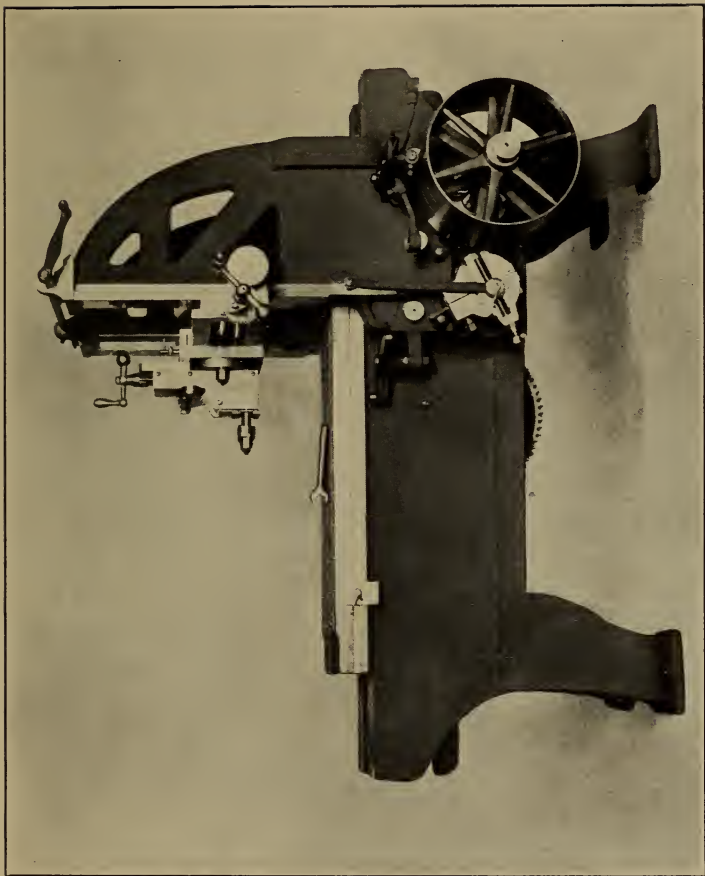

FIG. 2. MODERN PLANING MACHINE. ABSENCE OF ORNAMENTATION.

always to be condemned, as it tends to make the frame conform to the inequalities of the floor or foundation on what has been aptly termed the "caterpillar principle."

A distinction must be made between cabinets or supports which are broad at the base and intended to be fastened to the foundation, and legs similar to those of a table or chair. The latter are intended to simply rest on the floor, should be firmly fastened to the machine and should be larger at the upper end where the greatest bending moment will come.

The use of legs instead of cabinets is an assumption that the frame is stiff enough to withstand all stresses that come upon it, unaided by the foundation, and if that is the case intermediate supports are unnecessary.

Whether legs or cabinets are best adapted to a certain machine the designer must determine for himself.

Where two supports or pairs of legs are necessary under a frame, it is best to have them set a certain distance from the ends, and make the overhanging part of the frame of a parabolic form, as this divides up the bending moment and allows less deflection at the center. Trussing a long cast-iron frame with iron or steel rods is objectionable on account of the difference in expansion of the two metals and the liability of the tension nuts being tampered with by workmen.

The sprawling double curved leg which originated in the time of Louis XIV and which has served in turn for chairs, pianos, stoves and finally for engine lathes is wrong both from a practical and æsthetic standpoint. It is incorrect in principle and is therefore ugly.

EXERCISE.

1.—Apply the foregoing principles in making a written criticism of some engine or machine frame and its supports.

- (a) Girder frame of engine.
- (b) Tangye bed of air compressor.
- (c) Bed, uprights and supports of iron planing machine.
- (d) Bed and supports of engine lathe.
- (e) Cabinet of shaping or milling machine.
- (f) Frame of upright drill.

10. Machine Frames. For general principles of frame design the reader is referred to Chapter 2. Cast iron is the material most used but steel castings are now becoming common in situations where the stresses are unusually great, as in the frames of presses, shears and rolls for shaping steel.

Cored vs. Rib Sections. Formerly the flanged or rib section was used almost exclusively, as but a few castings were made from each pattern and the cost of the latter was a considerable item. Of late years the use of hollow sections has become more common; the patterns are more durable and more easily molded than those having many projections and the frames when finished are more pleasing in appearance.

The first cost of a pattern for hollow work, including the cost of the core-box, is sometimes considerably more but the pattern is less likely to change its shape and in these days of many castings from one pattern, this latter point is of more importance. Finally it may be said that hollow sections are usually stronger for the same weight of metal than any that can be shaped from webs and flanges.

Resistance to Bending. Most machine frames are exposed to bending in one or two directions. If the section is to be ribbed it should be of the form shown in Fig. 3. The metal being of nearly uniform thickness and the flange which is in tension having an area three or four times that of the compression flange. In a steel casting these may be more nearly equal. The hollow

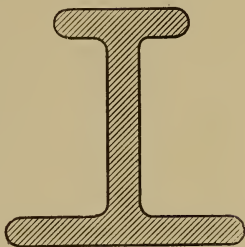

Fig. 3.

section may be of the shape shown in Fig. 4, a hollow rectangle with the tension side re-enforced and slightly thicker than the other three sides. The re-enforcing flanges at A and B may often be utilized for the attaching of other members to the frame as in shapers or drill presses. The box section has one great advantage over the I section in that its moment of resistance to side

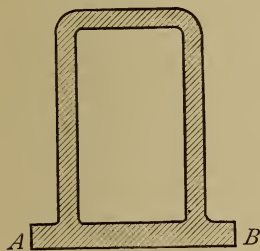

Fig. 4.

bending or to twisting is usually much greater. The double I or the U section is common where it is necessary to have two parallel ways for sliding pieces as in lathes and planers. As is shown in Fig. 5 the two Is are usually connected at intervals by cross girts.

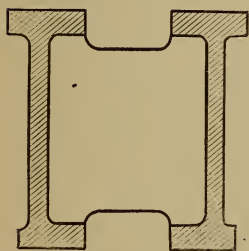

Fig. 5.

Besides making the cross-section of the most economical form, it is often desirable to have such a longitudinal profile as shall give a uniform fiber stress from end to

end. This necessitates a parabolic or elliptic outline of which the best instance is the housing or upright of a modern iron planer.

A series of experiments made in 1902 under the direction of the author, on the modulus of rupture of cast iron beams of the same weight but different cross-sections gave interesting results. Beginning with the solid circular section, which failed under a transverse load of 7,500 lb., square, rectangular, hollow and *I* shaped sections were tested until a maximum was reached in the *I* section with heavy tension flange which broke under a load of 38,000 lb. Channel and *T* shaped sections such as are appropriate for fly-wheel rims were also tested with the ribs in tension and in compression.

The strength of such sections was found to be from two to three times as great when the ribs were in compression as when they were in tension.

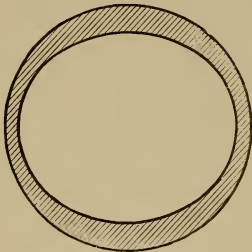

Fig. 6.

Resistance to Twisting. The hollow circular section is the ideal form for all frames or machine members which are subjected to torsion. If subjected also to bending the section may be made elliptical or, as is more common, thickened on two sides by making the core oval. See Fig. 6. As has already been pointed out the box sections are in general better

adapted to resist twisting than the ribbed or *I* sections.

Frames of Machine Tools. The beds of lathes are subjected to bending on account of their own weight and that of the saddle and on account of the downward

pressure on the tool when work is being turned. They are usually subjected to torsion on account of the uneven pressure of the supports. The box section is then the best; the double *I* commonly used is very weak against twisting. The same principle would apply in designing the beds of planers but the usual method of driving the table by means of a gear and rack prevents the use of the box section. The uprights of planers and the cross rail are subjected to severe bending moments and should have profiles of uniform strength. The uprights are also subject to side bending when the tool is taking a heavy side cut near the top. To provide for this the uprights may be of a box section or may be reinforced by outside ribs.

The upright of a drill press or vertical shaper is exposed to a constant bending moment equal to the upward pressure on the cutter multiplied by the distance from center of cutter to center of upright. It should then be of constant cross-section from the bottom to the top of the straight part. The curved or goose-necked portion should then taper gradually.

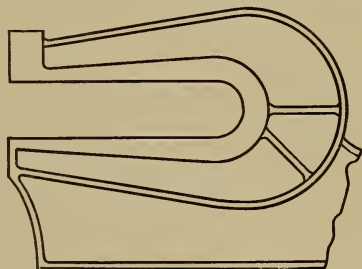

Fig. 7.

The frame of a shear press or punch is usually of the *G* shape in profile with the inner fibers in tension and the outer in compression. The cross-section should be as in Fig. 3 or Fig. 4, preferably the latter, and should be graduated to the magnitude of the bending moment at each point. (See Fig. 7.)

EXERCISES.

1. Discuss the stresses and the arrangement of material in the girder frame of a Corliss engine.
2. Ditto in the *G* frame of a band saw.

PROBLEM.

Design a *G* frame similar to that shown in Fig. 7, for a shear press capable of shearing a bar of mild steel $1\frac{1}{2}$ by $1\frac{1}{2}$ inches and having a gap four inches high and twenty-six inches deep.

CHAPTER III.

CYLINDER AND PIPES.

11. Thin Shells. Let Fig. 8 represent a section of a thin shell, like a boiler shell, exposed to an internal pressure of p pounds per sq. inch. Then, if we consider any diameter AB , the total upward pressure on upper half of the shell will balance the total downward pressure on the lower half and tend to separate the shell at A and B by tension.

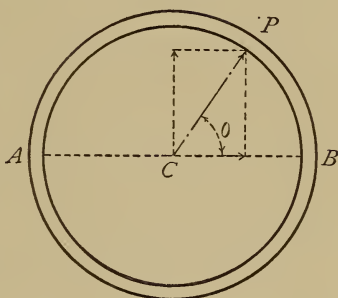

Fig. 8.

- Let
- d = diameter of shell in inches.
 - r = radius of shell in inches.
 - l = length of shell in inches.
 - t = thickness of shell in inches.
 - S = tensile strength of material.

Draw the radial line CP to represent the pressure on the element P of the surface.

Area of element at $P = lrd\theta$.

Total pressure on element $= plrd\theta$.

Vertical pressure on element $= plr \sin \theta d\theta$.

Total vertical pressure on $APB = \int_{\pi}^{\circ} plr \sin \theta d\theta = 2plr$.

12. Thick Shells. There are several formulas for thick cylinders and no one of them is entirely satisfactory. It is however generally admitted that the tensile stress caused by internal pressure in such a cylinder is greatest at the inner circumference and diminishes according to some law from there to the exterior of the shell. This law of variation is expressed differently in the different formulas.

Barlow's Formulas. Here the cylinder diameters are assumed to increase under the pressure, but in such a way that the volume of metal remains constant. Experiment has proved that in extreme cases this last assumption is incorrect. Within the limits of ordinary practice it is, however, approximately true.

Let d_1 and d_2 be the interior and exterior diameters in inches and let $t = \frac{d_2 - d_1}{2}$ be the thickness of metal.

Let l be the length of cylinder in inches.

Let S_1 and S_2 be the tensile stresses in lbs. per sq. inch at inner and outer circumferences.

The volume of the ring of metal before the pressure is applied will be :

$$V_1 = \frac{\pi l}{4}(d_2^2 - d_1^2)$$

and if the two diameters are assumed to increase the amounts x_1 and x_2 under pressure the final volume will be :

$$V_2 = \frac{\pi l}{4}[(d_2 + x_2)^2 - (d_1 + x_1)^2]$$

Assuming the volume to remain the same :

$$d_2^2 - d_1^2 = (d_2 + x_2)^2 - (d_1 + x_1)^2$$

Neglecting the squares of x_1 and x_2 this reduces to :

$$d_1 x_1 = d_2 x_2$$

or the distortions are inversely as the diameters.

The unit deformations will be proportional to

$$\frac{x_1}{d_2} \text{ and } \frac{x_2}{d_1}$$

and the stresses S_1 and S_2 will be in the same ratio :

$$\frac{S_1}{S_2} = \frac{x_1 d_2}{x_2 d_1} = \frac{d_2^2}{d_1^2} \dots \dots \dots (a)$$

or the stresses vary inversely as the squares of the diameters. Let S be the stress at any diameter d , then :

$$S = \frac{S_1 d_1^2}{d^2} = \frac{S_1 r_1^2}{r^2} \quad (\text{where } r \text{ is radius})$$

and the total stress on an element of the area $l.dr$ is :

$$\frac{S_1 r_1^2}{r^2} l dr = S_1 r_1^2 l \frac{dr}{r^2}$$

Integrating this expression between the limits $\frac{d_2}{2}$ and $\frac{d_1}{2}$ for r and multiplying by 2 we have :

$$P = 2 S_1 r_1^2 l \left(\frac{2}{d_1} - \frac{2}{d_2} \right) = 2 S_1 l \frac{d_1 t}{d_1 + 2t} \dots \dots \dots (b)$$

Equating this to the pressure which tends to produce rupture, pdl , where p is the internal unit pressure, there results :

$$p = \frac{2 S_1 t}{d_1 + 2t} \dots \dots \dots (16)$$

The formula (13) for thin shells gives $p = \frac{2St}{d}$.

By comparing this with formula (16) it will be seen that in designing thick shells the external diameter determines the working pressure or :

$$p = \frac{2 S_1 t}{d_2} \dots \dots \dots (16a)$$

Lamé's Formula.—In this discussion each particle of the metal is supposed to be subjected to radial compression and to tangential and longitudinal tension and to be in equilibrium under these stresses.

Using the same notation as in previous formula :

$$S_1 = \frac{d_2^2 + d_1^2}{d_2^2 - d_1^2} p_1 \quad \dots \quad (17)$$

for the maximum stress at the interior,

$$\text{and } S_2 = \frac{2d_1^2}{d_2^2 - d_1^2} p_1 \quad \dots \quad (18)$$

for the stress at the outer surface.

Fig. 9 illustrates the variation in S from inner to outer surface.

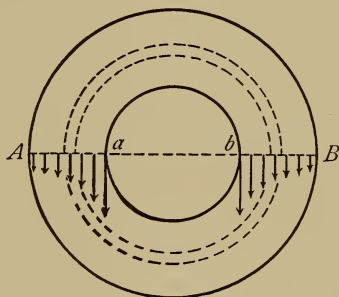

Fig. 9.

Solving for d_2 in (17) we have

$$d_2 = d_1 \sqrt{\frac{S_1 + p_1}{S_1 - p_1}} \quad \dots \quad (19)$$

A discussion of Lamé's formula may be found in most works on strength of materials.

PROBLEMS.

1. A hydraulic cylinder has an inner diameter of 8 inches, a thickness of four inches and an internal pressure of 1500 lbs. per sq. in. Determine the maximum stress on the metal by Barlow's and Lamé's formulas.
2. Design a cast-iron cylinder 6 inches internal diameter to carry a working pressure of 1200 lbs. per sq. in. with a factor of safety of 10.
3. A cast-iron water pipe is 1 inch thick and 12 inches internal diameter. Required head of water which it will carry with a factor of safety of 6.

13. Steel and Wrought Iron Pipe. Pipe for the transmission of steam, gas or water may be made of wrought iron or steel. Cast-iron is used for water mains to a certain extent, but its use for either steam or gas has been mostly abandoned. The weight of cast-iron pipe and its unreliability forbid its use for high pressure work.

Wrought iron pipe up to and including one inch in diameter is usually butt-welded, and above that is lap-welded. Steel pipes may be either welded or may be drawn without any seam. Electric welding has been successfully applied to all kinds of steel tubing, both for transmitting fluids and for boiler tubes.

The following tables are taken by permission from the catalogue of the Crane Company and show the standard dimensions for steam pipe and for boiler tubes.

Ordinary standard pipe is used for pressures not exceeding 100 lb. per sq. in., extra strong pipe for the pressures prevailing in steam plants where compound and triple expansion engines are used, while the double extra is employed in hydraulic work under the heavy pressures peculiar to that sort of transmission.

TABLE VI.
WROUGHT IRON AND STEEL STEAM, GAS AND WATER PIPE.
TABLE OF STANDARD DIMENSIONS.

Diameter.		Circumference.		Transverse Areas.			Length of Pipe per Square Foot of		Length of Pipe Containing One Cubic Foot.	Nominal Weight per Foot.	Number of Threads per inch of Screw.
Nominal External.	Actual External.	External.	Internal.	External.	Internal.	External.	Internal.				
Inches.	Inches.	Inches.	Inches.	Sq. Inch.	Sq. Inch.	Sq. Inch.	Feet.	Feet.	Pounds.		
$\frac{1}{8}$.405	1.272	.848	.129	.0573	.0717	9.44	14.15	.241	27	
$\frac{1}{4}$.54	1.696	1.144	.229	.1041	.1249	7.075	10.49	.42	18	
$\frac{3}{8}$.675	2.121	1.552	.358	.1917	.1663	5.657	7.73	.559	18	
$\frac{1}{2}$.84	2.639	1.957	.554	.3048	.2492	4.547	6.13	.837	14	
$\frac{3}{4}$	1.05	3.299	2.589	.866	.5333	.3327	3.637	4.635	1.115	14	
1	1.315	4.131	3.292	1.358	.8626	.4954	2.904	3.645	1.668	11½	
1½	1.66	5.215	4.335	2.164	1.496	.668	2.301	2.768	2.244	11½	
1¾	1.9	5.969	5.061	2.835	2.038	.797	2.01	2.371	2.678	11½	
2	2.375	7.461	6.494	4.43	3.356	1.074	1.608	1.848	3.609	11½	
2½	2.875	9.032	7.753	6.492	4.784	1.708	1.328	1.547	5.739	8	
3	3.5	10.996	9.636	9.621	7.388	2.243	1.091	1.245	7.536	8	

WROUGHT IRON AND STEEL STEAM, GAS AND WATER PIPE—(Continued).

TABLE OF STANDARD DIMENSIONS.

Diameter.		Nominal Thickness.	Circumference.		Transverse Areas.			Length of Pipe per Square Foot of		Length of Pipe Containing One Cubic Foot.	Nominal Weight per Foot.	Number of Threads per Inch of Screw.
Nominal Internal.	Approximate Internal Diameter.		External.	Internal.	External.	Internal.	External.	Internal Surface.				
Inches.	Inches.	Inches.	Inches.	Sq. Inch.	Sq. Inch.	Sq. Inch.	Feet.	Feet.	Feet.	Pounds.		
3½	3.548	.226	12.566	11.146	12.566	9.887	2.679	.955	1.077	14.57	9.001	8
4	4.026	.237	14.137	12.648	15.904	12.73	3.174	.849	.949	11.31	10.665	8
4½	4.508	.246	15.708	14.162	19.635	15.961	3.674	.764	.848	9.02	12.49	8
5	5.045	.259	17.477	15.849	24.306	19.99	4.316	.687	.757	7.2	14.502	8
6	6.065	.28	20.813	19.054	34.472	28.888	5.584	.577	.63	4.98	18.762	8
7	7.023	.301	23.955	22.063	45.664	38.738	6.926	.501	.544	3.72	23.271	8
8	7.982	.322	27.096	25.076	58.426	50.04	8.386	.443	.478	2.88	28.177	8
9	8.937	.344	30.238	28.076	72.76	62.73	10.03	.397	.427	2.29	33.701	8
10	10.019	.366	33.772	31.477	90.763	78.839	11.924	.355	.382	1.82	40.065	8
11	11.	36.914	34.558	108.434	95.033	13.401	.325	.347	1.51	45.028	8
12	12.75	40.055	37.7	127.677	113.098	14.579	.299	.319	1.27	48.985	8

TABLE VII.
WROUGHT IRON AND STEEL EXTRA STRONG PIPE.

TABLE OF STANDARD DIMENSIONS.

Diameter.		Nominal Thickness.	Nearest Wire Gauge.	Circumference.		Transverse Areas.			Length of Pipe per Square Foot of		Nominal Weight per Foot.
Nominal Internal.	Actual External.			External.	Internal.	Sq. Inches.	External.	Internal.	Metal.	External Surface.	
Inches.	Inches.	Inches.	No.	Inches.	Inches.	Sq. Inches.	Sq. Inches.	Sq. Inches.	Feet.	Feet.	Pounds.
3/8	.405	.205	12 1/2	1.272	.644	.129	.083	.086	9.433	18.632	.29
1/2	.54	.294	11	1.696	.924	.229	.068	.161	7.075	12.986	.54
5/8	.675	.421	10 1/2	2.121	1.323	.358	.189	.219	5.657	9.07	.74
3/4	.84	.542	9	2.639	1.703	.554	.231	.323	4.547	7.046	1.09
7/8	1.05	.736	8 1/2	3.299	2.312	.863	.452	.414	3.637	5.109	1.39
1	1.315	.951	7	4.131	2.988	1.358	.71	.648	2.904	4.016	2.17
1 1/4	1.66	1.272	6 1/2	5.215	3.996	2.164	1.271	.893	2.301	3.003	3.
1 1/2	1.9	1.494	6	5.969	4.694	2.885	1.753	1.082	2.01	2.556	3.63
2	2.375	1.983	5	7.461	6.073	4.43	2.935	1.495	1.608	1.975	5.02
2 1/2	2.875	2.315	2	9.032	7.273	6.492	4.209	2.283	1.328	1.649	7.67
3	3.5	2.892	1	10.996	9.085	9.621	6.569	3.052	1.091	1.328	10.25
3 1/2	4.	3.358	0	12.566	10.549	12.566	8.856	3.71	.955	1.137	12.47
4	4.5	3.818	0	14.137	11.995	15.904	11.449	4.455	.849	1.	14.97
5	5.563	4.813	00	17.477	15.120	24.306	18.193	6.12	.687	.793	20.54
6	6.625	5.75	000	20.813	18.064	34.472	25.967	8.505	.577	.664	28.58

Extra Strong Pipe is always shipped without Threads or Couplings, unless otherwise specified.

TABLE VIII.
WROUGHT IRON AND STEEL DOUBLE EXTRA STRONG PIPE.

TABLE OF STANDARD DIMENSIONS.

Diameter.		Nominal Thickness.	Nearest Wire Gauge.	Circumference.		Transverse Areas.				Length of Pipe per Square Foot of		Nominal Weight per Foot.
Nominal Internal.	Approximate Internal Diameter.			External.	Internal.	External.	Internal.	Metal.	External Surface.	Internal Surface.	Feet.	
Inches.	Inches.	Inches.	No.	Inches.	Inches.	Sq. Inches.	Sq. Inches.	Sq. Inches.	Sq. Inches.	Feet.	Feet.	Pounds.
½	.84	.214	1	2.639	.766	.554	.047	.507	.507	4.547	15.667	1.7
¾	1.05	.422	1	3.299	1.326	.866	.139	.727	.727	3.637	9.049	2.44
1	1.315	.587	00	4.131	1.844	1.358	.271	1.087	1.087	2.904	6.508	3.65
1¼	1.66	.885	00	5.215	2.78	2.164	.615	1.549	1.549	2.304	4.317	5.2
1½	1.9	1.088	000	5.969	3.418	2.835	.93	1.905	1.905	2.01	3.511	6.4
2	2.375	1.491	0000	7.461	4.684	4.43	1.744	2.686	2.686	1.608	2.561	9.02
2½	2.875	1.755	9/16--	9.032	5.513	6.492	2.419	4.073	4.073	1.328	2.176	13.68
3	3.5	2.284	5/8--	10.996	7.175	9.621	4.097	5.584	5.584	1.091	1.672	18.56
3½	4.	2.716	5/8X	12.566	8.533	12.566	5.794	6.772	6.772	.955	1.406	22.75
4	4.5	3.136	1 1/16--	14.137	9.852	15.904	7.724	8.18	8.18	.849	1.217	27.48
5	5.563	4.063	¾	17.477	12.764	24.306	12.965	11.34	11.34	.687	.940	38.12
6	6.625	4.875	¾	20.813	15.315	34.472	18.666	15.806	15.806	.577	.784	53.11

Double Extra Strong Pipe is always shipped without Threads or Couplings, unless otherwise specified.

Tests made by the Crane Company on ordinary commercial pipe such as is listed in Table VI showed the following pressures :

8 in. diam.	. . .	2000 lb. per sq. in.
10 " 	2300 " "
12 " 	1500 " "

The pipe was not ruptured at these pressures.

TABLE IX.
LAP-WELDED STEEL OR CHARCOAL IRON BOILER TUBES.
TABLE OF STANDARD DIMENSIONS.

Diameter.		Nominal Thickness.	Wire Gauge	Circumference.		Transverse Areas.				Length of Tube per Square Foot of		Nominal Weight per Foot.
External.	Internal.			External.	Internal.	External.	Internal.	Metal.	External Surface.	Internal Surface.	Feet.	
Inches.	Inches.	Inches.	No.	Inches.	Inches.	Sq. Inch.	Sq. Inch.	Sq. Inch.	Sq. Inch.	Feet.	Feet.	Pounds.
1	.856	.095	13	3.142	2.689	.785	.575	.21	.21	3.819	4.462	.90
1 $\frac{1}{4}$	1.106	.095	13	3.927	3.475	1.227	.961	.266	.266	3.056	3.453	1.15
1 $\frac{1}{2}$	1.334	.095	13	4.712	4.191	1.767	1.398	.369	.369	2.547	2.863	1.40
1 $\frac{3}{4}$	1.56	.095	13	5.498	4.901	2.405	1.911	.494	.494	2.183	2.448	1.66
2	1.81	.095	13	6.283	5.686	3.142	2.573	.569	.569	1.909	2.11	1.91
2 $\frac{1}{4}$	2.06	.095	13	7.069	6.472	3.976	3.333	.643	.643	1.698	1.854	2.16
2 $\frac{1}{2}$	2.282	.109	12	7.854	7.169	4.909	4.09	.819	.819	1.528	1.674	2.75
2 $\frac{3}{4}$	2.532	.109	12	8.639	7.954	5.94	5.035	.905	.905	1.389	1.509	3.04
3	2.782	.109	12	9.425	8.74	7.069	6.079	.99	.99	1.273	1.373	3.33
3 $\frac{1}{4}$	3.01	.12	11	10.21	9.456	8.296	7.116	1.18	1.18	1.175	1.26	3.96
3 $\frac{1}{2}$	3.26	.12	11	10.996	10.241	9.621	8.347	1.274	1.274	1.091	1.172	4.28
3 $\frac{3}{4}$	3.51	.12	11	11.781	11.027	11.045	9.676	1.369	1.369	1.018	1.088	4.6
4	3.732	.134	10	12.566	11.724	12.566	10.939	1.627	1.627	.955	1.024	5.47
4 $\frac{1}{2}$	4.232	.134	10	14.137	13.295	15.904	14.066	1.838	1.838	.849	.902	6.17
5	4.704	.148	9	15.708	14.778	19.635	17.379	2.256	2.256	.764	.812	7.58

LAP-WELDED STEEL OR CHARCOAL IRON BOILER TUBES—(Continued).

TABLE OF STANDARD DIMENSIONS.

Diameter.		Nominal Thickness.	Wire Gauge	Circumference.		Transverse Areas.				Length of Tube per Square Foot of		Nominal Weight per Foot.
External.	Internal.			External.	Internal.	External.	Internal.	External.	Internal.	External.	Internal.	
Inches.	Inches.	Inches.	No.	Inches.	Inches.	Sq. Inch.	Sq. Inch.	Sq. Inch.	Sq. Inch.	Feet.	Feet.	Pounds.
6	5.67	.165	8	18.85	17.813	28.274	25.249	3.025		.637	.673	10.16
7	6.67	.165	8	21.991	20.954	38.485	34.942	3.543		.546	.573	11.9
8	7.67	.165	8	25.133	24.096	50.266	46.204	4.062		.477	.498	13.65
9	8.64	.18	7	28.274	27.143	63.617	58.629	4.988		.424	.442	16.76
10	9.594	.203	6	31.416	30.14	78.54	72.292	6.248		.382	.398	21.
11	10.56	.22	5	34.558	33.175	95.033	87.588	7.45		.347	.362	25.03
12	11.542	.229	4½	37.699	36.26	113.098	104.629	8.469		.319	.33	28.46
13	12.524	.238	4	40.841	39.345	132.733	123.19	9.543		.294	.305	32.06
14	13.504	.248	3½	43.982	42.424	153.938	143.224	10.714		.273	.283	36.
16	15.432	.270	2½	50.26	48.48	201.06	187.04	14.02		.239	.248	45.20

NOTE.—In estimating effective steam-heating or evaporating surface of tubes, the surface in contact with air or gases of combustion, according to manner of application, as whether internal or external, is to be thus taken. For heating liquids by steam, superheating steam, or transferring heat from one liquid or one gas to another, mean surface of tubes to be computed.

14. Strength of Boiler Tubes. When tubes are used in a so-called fire-tube boiler with the gas inside and the water outside, they are exposed to a collapsing pressure.

The same is true of the furnace flues of internally fired boilers. Such a member is in unstable equilibrium and it is difficult to predict just when failure will occur.

Experiments on small wrought-iron tubes have shown the collapsing pressure to be about 80 per cent. of the bursting pressure. With short tubes set in tube sheets the length would have considerable influence on the strength, but ordinary boiler tubes collapsing at the middle of the length would not be influenced by the setting.

The strength of such tubes is probably proportional to $\left(\frac{t}{d}\right)^2$ where t is the thickness and d the diameter.

D. K. Clark gives for large iron flues the following formula:

$$P = \frac{200000 t^2}{d^{1.75}} \dots \dots \dots (20)$$

where P is the collapsing pressure in lb. per sq. in. These flues had diameters varying from 30 in. to 50 in. and thickness of metal from $\frac{3}{8}$ in. to $\frac{7}{16}$ in.

Prof. R. T. Stewart has recently made some interesting experiments on the collapsing pressure of lap-welded steel tubes and reported the results to the American Society of Mechanical Engineers. (See Transactions, Vol. XXVII.)

It will only be possible here to give some of the general conclusions, as stated by the author in his paper:

1. The length of tube, between transverse joints tending to hold it to a circular form, has no practical

influence upon the collapsing pressure of a commercial lap-welded steel tube so long as this length is not less than about six diameters of tube.

2. The formulae, as based upon the present research, for the collapsing pressure of modern lap-welded Bessemer steel tubes, are as follows :

$$P = 1000 \left(1 - \sqrt{1 - 1600 \frac{t^2}{d^2}} \right) \dots (A)$$

$$P = 86670 \frac{t}{d} \dots (B)$$

Where P = collapsing pressure, pounds per sq. inch.

d = outside diameter of tube in inches

t = thickness of wall in inches

Formula (A) is for values of P less than 581 pounds, or for values of $\frac{t}{d}$ less than 0.023, while formula (B) is for values greater than these.

These formulae, while strictly correct for tubes that are 20 feet in length between transverse joints tending to hold them to a circular form, are, at the same time, substantially correct for all lengths greater than about six diameters.

They have been tested for seven diameters, ranging from 3 to 10 inches, in all obtainable thicknesses of wall, and are known to be correct for this range.

3. The apparent fiber stress under which the different tubes failed varied from about 7000 pounds for the relatively thinnest to 35000 pounds per square inch for the relatively thickest walls.

Since the average yield point of the material was 37000 and the tensile strength 58000 pounds per square inch, it would appear that the strength of a tube subjected to a collapsing fluid pressure is not dependent

alone upon either the elastic limit or ultimate strength of the material constituting it.

15. Pipe Fittings. Steam pipe up to and including pipe two inches in diameter is usually equipped with screwed fittings, including ells, tees, couplings, valves, etc.

Pipe of a larger size, if used for high pressures, should be put together with flanged fittings and bolts. One great advantage of the latter system is the fact that a section of pipe can easily be removed for repairs or alterations.

Small connections are usually made of cast-iron or malleable iron. While the latter are neater in appearance they are more apt to stretch and cause leaky joints. The larger fittings are made of cast-iron or cast-steel. Such fittings can be obtained in various weights and thicknesses, to correspond to those grades of pipe listed in the tables.

The designer should have at hand catalogues of pipe fittings from the various manufacturers, as these will give in detail the proportions of all the different connections.

For pressures not exceeding 100 lbs. per sq. in. rubber and asbestos gaskets can be used between the flanges, but for higher pressures or for superheated steam corrugated metallic gaskets are necessary.

In 1905 some very interesting experiments on the strength of standard screwed elbows and tees were made by Mr. S. M. Chandler, a graduate of the Case School, and published by him in "Power" for October, 1905.

The fittings were taken at random from the stock of the Pittsburg Valve and Fittings Co., and three of

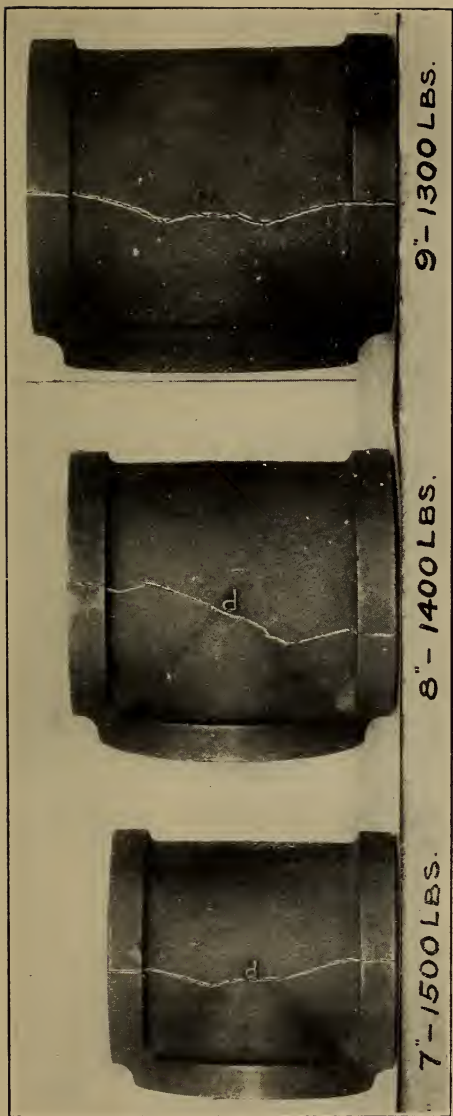

FIG. 10a. FRACTURED TEES, CHANDLER'S EXPERIMENTS.



FIG. 10b. FRACTURED ELLS, CHANDLER'S EXPERIMENTS.

each size were tested to destruction by hydraulic pressure.

The following table gives a summary of the results obtained. The values which are starred in the table were obtained from fittings which had purposely been cast with the core out of center so as to make one wall thinner than the other. These values are not included in the averages.

TABLE X.

BURSTING STRENGTH OF STANDARD SCREWED FITTINGS,
PRESSURES IN POUNDS PER SQUARE INCH.

SIZE.	ELBOWS.			AVERAGE.
2½	3500	3300	3400	3400
3	2400	2600	2100*	2500
3½	2100	1700*	2400	2250
4	2800	2500	2500	2600
4½	2000*	2600	2600	2600
5	2600	2500	2500	2533
6	2600	2200	2300	2367
7	1800	2100	1900*	1950
8	1700	1600	1700	1667
9	1800	1800	1900	1833
10	1800	1700	1600	1700
12	1100	1200	900*	1150

SIZE.	TEES.			AVERAGE.
1¼	3400	3300	3300	3333
1½	3400	3200	2800*	3300
2	2500	2800	2500	2600
2½	2400	2100*	2500	2450
3	1400*	1900	1800	1850
3½	1200*	1500	1800	1650
4	1800	2100	1700	1867
4½	1100*	1400	1400	1400
5	1700	1300*	1500	1600
6	1400	1500	1100*	1450
7	1400	1400	1500	1433
8	1200*	1400	1300	1350
9	1300	1400	1200	1300
10	1100	1300	1200	1200
12	1100	1000	1100	1067

* Made with eccentric core.

A formula which the writer has developed is somewhat similar to Van Buren's.

Let s' = tangential stress due to internal pressure.

Then by equation for thin shells

$$s' = \frac{pd}{2t}$$

Let s'' be an additional tensile stress due to distortion of the circular section at any weak point.

Then if we regard one-half of the circular section as a beam fixed at A and B (Fig. 11) and assume the maximum bending moment as at C some weak point, the tensile stress on the outer fibres at C due to the bending will be proportional to $\frac{pd^2}{t^2}$ by the laws of flexure, or

$$s'' = \frac{cpd^2}{t^2}$$

where c is some unknown constant.

The total tensile stress at C will then be

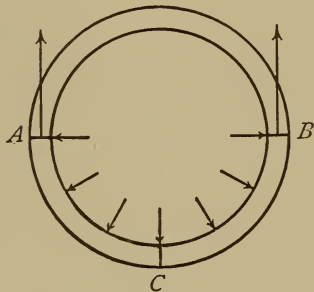

Fig. 11.

$$S = s' + s'' = \frac{pd}{2t} + \frac{cpd^2}{t^2}$$

Solving for c $c = \frac{St^2}{pd^2} - \frac{t}{2d}$ (a)

Solving for t $t = \frac{pd}{4S} + \sqrt{\frac{cpd^2}{S} + \frac{p^2d^2}{16S^2}}$ (22)

a form which reduces to that of equation (13) when $c=0$.

An examination of several engine cylinders of

standard manufacture shows values of c ranging from .03 to .10, with an average value :

$$c = .06.$$

The formula proposed by Professor Barr, in his paper on * "Current Practice in Engine Proportions," as representing the average practice among builders of low speed engines is :

$$t = .05 d + .3 \text{ inch.} \quad \dots \dots \dots (23)$$

In Kent's Mechanical Engineer's Pocket Book, the following formula is given as representing closely existing practice :

$$t = .0004 dp + 0.3 \text{ inch.} \quad \dots \dots \dots (24)$$

This corresponds to Barr's formula if we take $p = 125$ pounds per square inch.

Experiments † made at the Case School of Applied Science in 1896-97 throw some light on this subject. Cast iron cylinders similar to those used on engines were tested to failure by water pressure. The cylinders varied in diameter from six to twelve inches and in thickness from one-half to three-quarters inches.

Contrary to expectations most of the cylinders failed by tearing around a circumference just inside the flange. (See Fig. 12).

* Transactions A. S. M. E., vol. xviii, p. 741.

† Transactions A. S. M. E. vol. xix.

TABLE XI.

No.	Diam. <i>d</i>	Pres- sure. <i>p</i>	Thick- ness. <i>t</i>	Line of Failure.	Formulas Used.			Strength of Test-bar.
					13 $S = \frac{pd}{2t}$	14 $S = \frac{pd}{4t}$	a <i>c</i> =	
a	12.16	800	.70	Circum.	6940	3470	.046	18000 lbs.
d	12.45	700	.56	Longi.	7780	—	.047	24000 lbs.
e	9.12	1325	.61	Circum.	9900	4950	.048	24000 lbs.
f	6.12	2500	.65	Circum.	11800	5900	.055	24000 lbs.
1	9.58	600	.402	Longi.	7150	—	.049	24000 lbs.
2	9.375	1050	.573	Circum.	8590	4300	.055	24000 lbs.
3	9.13	975	.596	Circum.	7470	3740	.072	24000 lbs.
4	12.53	700	.571	Longi.	7680	—	.048	24000 lbs.
5	12.56	875	.531	Circum.	10350	5180	.028	24000 lbs.

Average of $c = .05$

Table XI gives a summary of the results.

Out of nine cylinders so tested, only three failed by splitting longitudinally.

This appears to be due to two causes. In the first place, the flanges caused a bending moment at the junction with the shell due to the pull of the bolts. In the second place, the fact that the flanges were thicker than the shell caused a zone of weakness near the flange due to shrinkage in cooling, and the presence of what founders call "a hot spot."

The stresses figured from formula (14) in the cases where the failure was on a circumference, are from one-fifth to one-sixth the tensile strength of the test bar.

The strength of a chain is the strength of the weakest link, and when the tensile stress exceeded the strength of the metal near some blow hole or "hot spot," tearing began there and gradually extended around the circumference.

Values of c as given by equation (a) have been calculated for each cylinder, and agree fairly well, the average value being $c=.05$.

To the criticism that most of the cylinders did not fail by splitting, and that therefore formulas (a) and (22) are not applicable, the answer would be that the chances of failure in the two directions seem about equal, and consequently we may regard each cylinder as about to fail by splitting under the final pressure.

If we substitute the average value of $c=.05$ and a safe value of $s=2000$, formula (21) reduces to :

$$t = \frac{pd}{8000} + \frac{d}{200} \sqrt{p + \frac{p^2}{1600}} \quad \dots \quad (25)$$

* Subsequent experiments made at the Case School in 1904 show the effect of stiffening the flanges by brackets.

Four cylinders were tested, each being 10 inches internal diameter by 20 inches long and having a thickness of about $\frac{3}{4}$ inches. The flanges were of the same thickness as the shell and were re-enforced by sixteen triangular brackets as shown in Fig. 13.

The fractures were all longitudinal there being but little of the tearing around the shell which was so marked a feature of the former experiments. This shows that the brackets served their purpose.

Table XII gives the results of the tests and the calculated values of c .

* Machinery, N. Y., Nov. 1905.

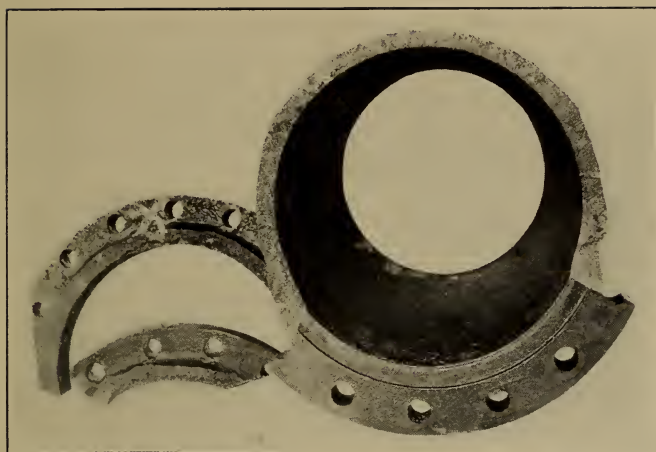

FIG. 12. FRACTURED CYLINDER.



FIG. 13. FRACTURED CYLINDER.

TABLE XII.

BURSTING PRESSURE OF CAST-IRON CYLINDERS.

Internal Diameter.	Average Thickness.	Bursting Pressure.	Value of c .	$S = \frac{pd}{2t}$.
10.125	0.766	1350	.0213	9040
10.125	0.740	1400	.0152	10200
10.125	0.721	1350	.0126	9735
10.125	0.720	1200	.0177	9080

Average value of $c = .0167$.

Comparing the values in the above table with those in Table XI we find c to be only one-third as large.

The tensile strength of the metal in the last four cylinders, as determined from test bars, was only 14000 lbs. per sq. in.

Comparison with the values of S due to direct tension as given by the formula

$$S = \frac{pd}{2t}$$

shows that in a cylinder of this type about one-third of the stress is "accidental" and due to lack of uniformity in the conditions. In Table XI about two-thirds must be thus accounted for.

PROBLEMS.

1. Referring to Table XI, verify in at least three experiments the values of S and c as there given. Do the same in Table XII.

2. The steam cylinder of a Baldwin locomotive is 22 ins. in diameter and 1.25 ins. thick. Assuming 125 lbs. gauge pres-

sure, find the value of c . Calculate thickness by Van Buren's and Barr's formulas.

3. Determine proper thickness for cylinder of cast-iron, if the diameter is 38 inches and the steam pressure 100 lbs. by formulas 13, 21, 23, 24 and 25.

4. The cylinder of a stationary engine has internal diameter =12 in. and thickness of shell =1 in. Find the value of c for $p=120$ lbs. per sq. in.

17. Thickness of Flat Plates. An approximate formula for the thickness of flat cast-iron plates may be derived as follows :

Let l =length of plate in inches.

b =breadth of plate in inches.

t =thickness of plate in inches.

p =intensity of pressure in pounds.

S =modulus of rupture lbs. per sq. in.

A plate which is supported or fastened at all four edges is constrained so as to bend in two directions at right angles. Now if we suppose the plate to be represented by a piece of basket work with strips crossing each other at right angles we may consider one set of strips as resisting one species of bending and the other set as resisting the other bending. We may also consider each set of strips as carrying a fraction of the total load. The equation of condition is that each pair of strips must have a common deflection at the crossing.

Suppose the plate to be divided lengthwise into flat strips an inch wide l inches long, and suppose that a fraction p' of the whole pressure causes the bending of these strips.

Regarding the strips as beams with fixed ends and uniformly loaded :

$$S = \frac{6M}{bh^2} = \frac{6Wl}{12bh^2} = \frac{p'l^2}{2t^2}$$

and the thickness necessary to resist bending is :

$$t = l \sqrt{\frac{p'}{2S}} \dots \dots \dots (a)$$

In a similar manner, if we suppose the plate to be divided into transverse strips an inch wide and b inches long, and suppose the remainder of the pressure $p - p'$ equals p'' to cause the bending in this direction, we shall have :

$$t = b \sqrt{\frac{p''}{2S}} \dots \dots \dots (b)$$

But as all these strips form one and the same plate the ratio of p' to p'' must be such that the deflection at the center of the plate may be the same on either supposition. The general formula for deflection in this case is

$$\Delta = \frac{Wl^3}{384 EI}$$

and $I = \frac{t^3}{12}$ for each set of strips. Therefore the deflec-

tion is proportional to $\frac{p'l^4}{t^3}$ and $\frac{p''b^4}{t^3}$ in the two cases.

$$\therefore p'l^4 = p''b^4$$

But $p' + p'' = p$

Solving in these equations for p' and p''

$$p' = \frac{pb^4}{l^4 + b^4}$$

$$p'' = \frac{pl^4}{l^4 + b^4}$$

Substituting these values in (a) and (b) :

$$t = l^2 \sqrt{\frac{p}{2S(l^4 + b^4)}} \dots \dots \dots (26)$$

$$t = b^2 \sqrt{\frac{p}{2S(l^4 + b^4)}} \dots \dots \dots (27)$$

As $l > b$ usually, equation (27) is the one to be used. If the plate is square $l = b$ and

$$t = \frac{b}{2} \sqrt{\frac{p}{S}} \dots \dots \dots (28)$$

If the plate is merely supported at the edges then formulas (26) and (27) become :

For rectangular plate :

$$t = \frac{bl^2}{2} \sqrt{\frac{3p}{S(l^4 + b^4)}} \dots \dots \dots (29)$$

For square plate :

$$t = \frac{b}{2} \sqrt{\frac{3p}{2S}} \dots \dots \dots (30)$$

A round plate may be treated as square, with side=diameter, without sensible error.

The preceding formulas can only be regarded as approximate. Grashof has investigated this subject and developed rational formulas but his work is too long and complicated for introduction here. His formulas for round plates are as follows :

Round plates :

Supported at edges :

$$t = \frac{d}{2} \sqrt{\frac{5p}{6S}} \dots \dots \dots (31)$$

Fixed at edges :

$$t = \frac{d}{2} \sqrt{\frac{2p}{3S}} \dots \dots \dots (32)$$

where t and p are the same as before, d is the diameter in inches and S is the safe tensile strength of the material.

Comparing these formulas with (28) and (30) for square plates, they are seen to be nearly identical if allowance is made for the difference in the value of S .

Experiments made at the Case School of Applied Science in 1896-97 on rectangular cast iron plates with load concentrated at the center gave results as follows: Twelve rectangular plates planed on one side and each having an unsupported area of 10 by 15 inches were broken by the application of a circular steel plunger one inch in diameter at the geometrical center of each plate. The plates varied in thickness from one-half inch to one and one-eighth inches. Numbers 1 to 6 were merely supported at the edges, while the remaining six were clamped rigidly at regular intervals around the edge.

To determine the value of S , the modulus of rupture of the material, pieces were cut from the edge of the plates and tested by cross-breaking. The average value of S from seven experiments was found to be 33000 lbs. per sq. in.

In Table XIII are given the values obtained for the breaking load W under the different conditions.

If we assume an empirical formula:

$$W = k \frac{St^2}{l^2 + b^2} \dots \dots \dots (a)$$

and substitute given values of S , l and b we have nearly:

$$W = 100kt^2 \dots \dots \dots (b)$$

Substituting values of W and t from the Table XIII we have the values of k as given in the last column.

If we average the values for the two classes of plates and substitute in (a) we get the following empirical formulas :

For breaking load on plates supported at the edges and loaded at the center :

$$W = 276 \frac{St^2}{l^2 + b^2} \dots \dots \dots (31)$$

and for similar plates with edges fixed :

$$W = 442 \frac{St^2}{l^2 + b^2} \dots \dots \dots (32)$$

S in both formulas is the modulus of rupture.

TABLE XIII.

CAST IRON PLATES 10×15 INS.

No.	Thickness t	Breaking Load. W	Constant. k
1	.562	7500	237
2	.641	11840	288
3	.745	14800	267
4	.828	21900	320
5	1.040	31200	289
6	1.120	31800	254
7	.481	9800	424
8	.646	17650	422
9	.769	26400	446
10	.881	33400	430
11	1.020	47200	454
12	1.123	59600	477

Those plates which were merely supported at the edges broke in three or four straight lines radiating from the center. Those fixed at the edges broke in four or five radial lines meeting an irregular oval inscribed in the rectangle. Number 12 however failed by shearing, the circular plunger making a circular hole in the plate with several radial cracks.

Some tests were made in the spring of 1906 at the Case School laboratories by Messrs. Hill and Nadig on the strength of flat cast-iron plates under uniform hydraulic pressure.

The plates tested were of soft gray iron, having a low tensile strength of about 12000 lbs. per square inch, and were of the following sizes :

12 by 12 by $\frac{3}{4}$ inches.

12 by 12 by 1 inches.

12 by 18 by 1.25 inches.

12 by 18 by $\frac{1}{16}$ inches.

These burst at the following pressures respectively :

375 lbs. 675 lbs. 650 lbs. 450 lbs.

The fractures started at the center of the plates and ran to the sides in irregular lines. The square plates were somewhat weaker than would have been expected from the formula and the rectangular plates somewhat stronger.

PROBLEMS.

1. Calculate the thickness of a steam-chest cover 8×12 inches to sustain a pressure of 90 lbs. per sq. inch with a factor of safety = 10.

2. Calculate the thickness of a circular manhole cover of cast-iron 18 inches in diameter to sustain a pressure of 150 lbs. per sq. inch with a factor of safety = 8, regarding the edges as merely supported.

3. Determine the probable breaking load for a plate 18 by 24 in. loaded at the center, (a) when edges are fixed. (b) When edges are supported.

4. In experiments on steam cylinders, a head 12 inches in diameter and 1.18 inches thick failed under a pressure of 900 lbs. per sq. in. Determine the value of S by formula (28).

CHAPTER IV.

FASTENINGS.

18. Bolts and Nuts. Tables of dimensions for U. S. standard bolt heads and nuts are to be found in most engineering hand-books and will not be repeated here.

These proportions have not been generally adopted on account of the odd sizes of bar required. The standard screw-thread has been quite generally accepted as superior to the old V-thread.

Roughly the diameter at root of thread is 0.83 of the outer diameter in this system, and the pitch in inches is given by the formula

$$p = .24\sqrt{d + .625} - .175. \quad \dots \quad (33)$$

where d = outer diameter.

TABLE XIV.

SAFE WORKING STRENGTH OF IRON OR STEEL BOLTS.

Diam. of Bolt. — Inch.	Thr'ds per Inch. — No.	Diam. at Root of Thread. Inches.	Area at Root of Thread. Sq. In.	Safe Load in Tension. Lb.		Safe Load in Shear. Lb.	
				5000 lb. per sq. in.	7500 lb. per sq. in.	4000 lb. per sq. in.	6000 lb. per sq. in.
$\frac{1}{4}$	20	.185	.0269	135	202	196	294
$\frac{5}{16}$	18	.240	.0452	226	340	306	460
$\frac{3}{8}$	16	.294	.0679	340	510	440	660
$\frac{7}{16}$	14	.344	.0930	465	695	600	900
$\frac{1}{2}$	13	.400	.1257	628	940	785	1175

TABLE XIV (Continued).

SAFE WORKING STRENGTH OF IRON OR STEEL BOLTS.

Diam. of Bolt. — Inch.	Thr'ds per Inch. — No.	Diam. at Root of Thread. Inches.	Area at Root of Thread. Sq. In.	Safe Load in Tension. Lb.		Safe Load in Shear. Lt.	
				5000 lb. per sq. in.	7500 lb. per sq. in.	4000 lb. per sq. in.	6000 lb. per sq. in.
$\frac{9}{16}$	12	.454	.162	810	1210	990	1485
$\frac{5}{8}$	11	.507	.202	1010	1510	1230	1845
$\frac{3}{4}$	10	.620	.302	1510	2260	1770	2650
$\frac{7}{8}$	9	.731	.420	2100	3150	2400	3600
1	8	.837	.550	2750	4120	3140	4700
$1\frac{1}{8}$	7	.940	.694	3470	5200	3990	6000
$1\frac{1}{4}$	7	1.065	.891	4450	6680	4910	7360
$1\frac{3}{8}$	6	1.160	1.057	5280	7920	5920	7880
$1\frac{1}{2}$	6	1.284	1.295	6475	9710	7070	10600
$1\frac{5}{8}$	$5\frac{1}{2}$	1.389	1.515	7575	11350	8250	12375
$1\frac{3}{4}$	5	1.490	1.744	8720	13100	9630	14400
$1\frac{7}{8}$	5	1.615	2.049	10250	15400	11000	16500
2	$4\frac{1}{2}$	1.712	2.302	11510	17250	12550	18800

The shearing load is calculated from the area of the body of the bolt.

Bolts may be divided into three classes which are given in the order of their merit.

1. Through bolts, having a head on one end and a nut on the other.

2. Stud bolts, having a nut on one end and the other screwed into the casting.

3. Tap bolts or screws having a head at one end and the other screwed into the casting.

The principal objection to the last two forms and especially to (3) is the liability of sticking or breaking off in the casting.

Any irregularity in the bearing surfaces of head or nut where they come in contact with the casting, causes a bending action and consequent danger of rupture.

This is best avoided by having a slight annular projection on the casting concentric with the bolt hole and finishing the flat surface by planing or counter-boring.

Counter-boring without the projection is a rather slovenly way of overcoming the difficulty.

When bolts or studs are subjected to severe stress and vibration, it is well to turn down the body of the bolt to the diameter at root of thread, as the whole bolt will then stretch slightly under the load.

A check nut is a thin nut screwed firmly against the main nut to prevent its working loose, and is commonly placed outside.

As the whole load is liable to come on the outer nut, it would be more correct to put the main nut outside. (Prove this by figure.)

After both nuts are firmly screwed down, the outer one should be held stationary and the inner one reversed against it with what force is deemed safe, that the greater reaction may be between the nuts.

Numerous devices have been invented for the purpose of holding nuts from working loose under vibration but none of them are entirely satisfactory.

Probably the best method for large nuts is to drive a pin or cotter entirely through nut and bolt.

A flat plate, cut out to embrace the nut and fastened to the casting by a machine screw, is often used.

19. **Machine Screws.** A screw is distinguished from a bolt by having a slotted, round head instead of a square or hexagon head.

The head may have any one of four shapes, the round, fillister, oval fillister and flat as shown in Fig. 14. A committee of the American Society of Mechanical Engineers has recently recommended certain standards for machine screws.* The form of thread recommended is the U. S. Standard or Sellers type with provision for clearance at top and bottom to insure bearing on the body of the thread.

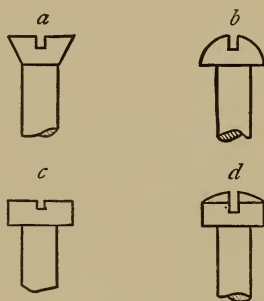

Fig. 14.

The sizes and pitches recommended are as follows :

TABLE XV.
MACHINE SCREWS.

Standard Diameter.	.070	.085	.100	.110	.125	.140	.165	.190	.215	.240	.250	.270	.320	.375
Threads per inch.	72	64	56	48	44	40	36	32	28	24	24	22	20	16

Reference is made to the report itself for further details of heads, taps, etc.

20. **Eye Bolts and Hooks.** In designing eye bolts it is customary to make the combined sectional area of the sides of the eye one and one half-times that of the bolt to allow for obliquity and an uneven distribution of stress.

Large hooks should be designed to resist combined

* Trans. A. S. M. E., Vol. xxvii.

bending and tension ; the bending moment is equal to the load multiplied by the longest perpendicular from the center line of hook to line of load.

The tension due to this bending must be added to the direct tension and the body of the hook designed accordingly.

PROBLEMS.

1. Discuss the effect of the initial tension caused by the screwing up of the nut on the bolt, in the case of steam fittings, etc. ; *i. e.* should this tension be added to the tension due to the steam pressure, in determining the proper size of bolt ?

2. Determine the number of $\frac{3}{4}$ inch steel bolts necessary to hold on the head of a steam cylinder 15 inches diameter, with the internal pressure 90 pounds per square inch, and factor of safety = 12.

3. Show what is the proper angle between the handle and the jaws of a fork wrench.

(1) If used for square nuts ;

(2) If used for hexagon nuts ; illustrate by figure.

4. Determine the length of nut theoretically necessary to prevent stripping of the thread, in terms of the outer diameter of the bolt.

(1) With U. S. standard thread.

(2) With square thread of same depth.

5. Design a hook with a swivel and eye at the top to hold a load of one ton with a factor of safety 5, the center line of hook being three inches from line of load, and the material wrought iron.

21. Riveted Joints. Riveted joints may be divided into two general classes : lap joints where the two plates lap over each other, and butt joints where the edges of the plates butt together and are joined by over-lapping straps or welts. If the strap is on one

side only, the joint is known as a butt joint with one strap; if straps are used inside and out the joint is called a butt joint with two straps. Butt joints are generally used when the material is more than one half inch thick.

Any joint may have one, two or more rows of rivets and hence be known as a single riveted joint, a double riveted joint, etc.

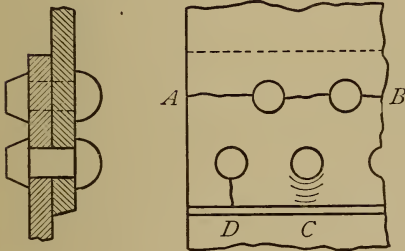

Fig. 15.

Any riveted joint is weaker than the original plate, simply because holes cannot be punched or drilled in the plate for the introduction of rivets without removing some of the metal.

Fig. 15 shows a double riveted lap joint and Fig. 16 a single riveted butt joint with two straps.

Riveted joints may fail in any one of four ways:

1. By tearing of the plate along a line of rivet holes, as at AB, Fig. 15.

2. By shearing of the rivets.

3. By crushing and wrinkling of the plate in front of each rivet as at C, Fig. 15, thus causing leakage.

4. By splitting of the plate opposite each rivet as at D, Fig. 15. The last manner of failure may be pre-

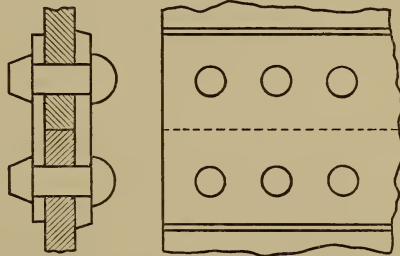

Fig. 16.

vented by having a sufficient distance from the rivet to the edge of the plate. Practice has shown that this distance should be at least equal to the diameter of a rivet.

Experience has shown that lap joints in plates of even moderate thickness are dangerous on account of the liability of hidden cracks. Several disastrous boiler explosions have resulted from the presence of cracks inside the joint which could not be detected by inspection. The fact that one or both plates are out of the line of pull brings a bending moment on both plates and rivets.

Some boiler inspectors have gone so far as to condemn lap-joints altogether.

Let t = thickness of plate.

d = diameter of rivet-hole.

p = pitch of rivets.

n = number of rows of rivets.

T = tensile strength of plate.

C = crushing strength of plate or rivet.

S = Shearing strength of rivet.

Average values of the constants are as follows :

Material.	T	C	S
Wrought Iron.....	50 000	80 000	40 000
Soft Steel.....	56 000	90 000	45 000

The values of the constants given above are only average values and are liable to be modified by the exact grade of material used and the manner in which it is used.

The tensile strength of soft steel is reduced by punching from three to twelve per cent according to the kind of punch used and the width of pitch. The shearing strength of the rivets is diminished by their tendency to tip over or bend if they do not fill the holes, while the bearing or compression is doubtless relieved to some extent by the friction of the joint. The values given allow roughly for these modifications.

22. Lap Joints. This division also includes butt joints which have but one strap.

Let us consider the shell as divided into strips at right angles to the seam and each of a width = p . Then the forces acting on each strip are the same and we need to consider but one strip.

The resistance to tearing across of the strip between rivet holes is $(p-d)tT$ (a)
and this is independent of the number of rows of rivets.

The resistance to compression in front of rivets is $ndtC$ (b)

and the resistance to shearing of the rivets is $\frac{\pi}{4}nd^2S$ (c)

If we call the tensile strength T = unity then the relative values of C and S are 1.6 and 0.8 respectively.

Substituting these relative values of T , C and S in our equations, by equating (b) and (c) and reducing we have $d = 2.55t$ (34)

Equating (a) and (c) and reducing we have

$$p = d + .628 \frac{nd^2}{t} (35)$$

Or by equating (a) and (b)

$$p = d + 1.6nd. \quad \dots \dots \dots (36)$$

These proportions will give a joint of equal strength throughout, for the values of constants assumed.

23. Butt Joints with two Straps. In this case the resistance to shearing is increased by the fact that the rivets must be sheared at both ends before the joint can give away. Experiment has shown this increase of shearing strength to be about 85 per cent and we can therefore take the relative value of S as 1.5 for butt joints.

This gives the following values for d and p

$$d = 1.36t. \quad \dots \dots \dots (37)$$

$$p = d + 1.18 \frac{nd^2}{t}. \quad \dots \dots \dots (38)$$

$$p = d + 1.6nd. \quad \dots \dots \dots (39)$$

In the preceding formulas the diameter of hole and rivet have been assumed to be the same.

The diameter of the cold rivet before insertion will be $\frac{1}{16}$ inches less than the diameter given by the formulas.

Experiments made in England by Prof. Kennedy give the following as the proportions of maximum strength :

Lap joints	$d = 2.33t$
	$p = d + 1.375nd$

Butt joints	$d = 1.8t$
	$p = d + 1.55nd$

24. Efficiency of Joints. The efficiency of joints designed like the preceding is simply the ratio of the section of plate left between the rivets to the section

of solid plate, or the ratio of the clear distance between two adjacent rivet holes to the pitch. From formula (35) we thus have.

$$\text{Efficiency} = \frac{1.6n}{1+1.6n} \dots \dots \dots (40)$$

This gives the efficiency of single, double and triple riveted seams as

.615, .762 and .828 respectively.

Notice that the advantage of a double or triple riveted seam over the single is in the fact that the pitch bears a greater ratio to the diameter of a rivet, and therefore the proportion of metal removed is less.

25. Butt Joints with unequal Straps. One joint in common use requires special treatment.

It is a double-riveted butt joint in which the inner strap is made wider than the outer and an extra row of rivets added, whose pitch is double that of the original seam; this is sometimes called diamond riveting. See Fig. 17.

This outer row of rivets is then exposed to single shear and the original rows to double shear.

Consider a strip of plate of a width = $2p$. Then the resistance to tearing along the outer row of rivets is

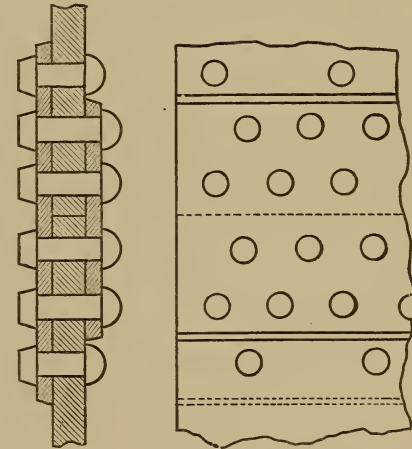

Fig. 17.

$$(2p-d)tT$$

TABLE XVI.
RIVETED LAP JOINTS.

Thick- ness of Plate.	Diam. of Rivet.	Diam. of Hole.	Pitch.		Efficiency of Plate.	
			Single.	Double.	Single.	Double.
$\frac{1}{4}$	$\frac{1}{2}$	$\frac{9}{16}$	$1\frac{3}{8}$	$1\frac{1}{2}$.59	.68
$\frac{5}{16}$	$\frac{5}{8}$	$\frac{11}{16}$	$1\frac{5}{8}$	$2\frac{1}{8}$.58	.68
$\frac{3}{8}$	$\frac{3}{4}$	$1\frac{3}{8}$	$1\frac{7}{8}$	$2\frac{1}{2}$.57	.67
$\frac{7}{16}$	$1\frac{3}{16}$	$\frac{7}{8}$	2	$2\frac{1}{4}$.56	.68
$\frac{1}{2}$	$\frac{7}{8}$	$1\frac{5}{16}$	2	$2\frac{7}{8}$.53	.67

The efficiencies are calculated from the strength of plate between rivet holes and the efficiencies of the rivets may be even lower. Comparing these values with the ones given in Art. 24 we find them low. This is due to the fact that the pitches assumed are too small. The only excuse for this is the possibility of getting a tighter joint.

TABLE XVII.
RIVETED BUTT JOINTS.

Thickness of Plate.	Diam. of Rivet.	Diam. of Hole.	Pitch.		
			Single.	Double.	Triple.
$\frac{1}{2}$	$\frac{3}{4}$	$1\frac{3}{8}$	$2\frac{3}{8}$	4	$5\frac{1}{2}$
$\frac{5}{8}$	$1\frac{3}{16}$	$\frac{7}{8}$	$2\frac{3}{8}$	$3\frac{3}{4}$	$5\frac{1}{4}$
$\frac{3}{4}$	$\frac{7}{8}$	$1\frac{5}{8}$	$2\frac{3}{8}$	$3\frac{3}{4}$	$5\frac{3}{8}$
$\frac{7}{8}$	$1\frac{5}{16}$	1	$2\frac{3}{8}$	$3\frac{3}{4}$	5
1	1	$1\frac{1}{16}$	$2\frac{3}{8}$	$3\frac{3}{4}$	5

Table XVII has been calculated for butt joints with two straps. As in the preceding table the values of the pitch are too small for the best efficiency. The tables are only intended to illustrate common practice and not to serve as standards. There is such a diversity of practice among manufacturers that it is advisable for the designer to proportion each joint according to his own judgment, using the rules of Arts. 22-25 and having regard to the practical considerations which have been mentioned.

A committee of the Master Steam Boiler Makers' Association has made a number of tests on riveted joints and reported its conclusions. The specimens were prepared according to generally accepted practice, but on subjecting them to tension many of them failed by tearing through from hole to edge of plate. The committee recommends making this distance greater, so that from the center of hole to edge of plate shall be perhaps $2d$ instead of $1.5d$.

The committee further found the shearing strength of rivets to be in pounds per square inch of section.

	Single Shear.	Double Shear.
Iron rivets.....	40000	78000
Steel rivets.....	49000	84000

Compare these values with those given in Art. 21. Also note that the factor for double shear is 1.95 for iron rivets and only 1.71 for steel rivets as against the 1.85 given in Art. 23. The committee found that machine-driven rivets were stronger in double shear than hand-driven ones.

PROBLEMS.

1. Calculate diameter and pitch of rivets for $\frac{1}{4}$ in. and $\frac{1}{2}$ in. plate and compare results with those in Table XVI. Criticise latter.

2. Show the effect in Prob. 1 of using iron rivets in steel plates.

3. Criticise proportions of joints for $\frac{1}{2}$ in. and 1 in. plate in Table XVII. by testing the efficiency of rivets and plates.

4. A cylinder boiler 5×16 ft. is to have long seams double-riveted laps and ring seams single riveted laps. If the internal pressure is 90 lbs. gauge pressure and the material soft steel, determine thickness of plate and proportion of joints. The net factor of safety at joints to be five.

5. A marine boiler is 11 ft. 6 ins. in diameter and 14 ft long. The long seams are to be diamond riveted butt joints and the ring seams ordinary double riveted butt joints. The internal pressure is to be 175 lbs. gauge and the material is to be steel of 60,000 lbs. tensile strength. Determine thickness of shell and proportions of joints. Net factor of safety to be 5, as in Prob. 4.

6. Design a diamond riveted joint such as shown in Fig 18 for a steel plate $\frac{5}{8}$ in. thick. Outer cover plate is $\frac{5}{8}$ in. and inner cover plate is $\frac{7}{16}$ inches thick ; the pitch of outer rows of rivets to be twice that of inner rows. Determine efficiency of joints.

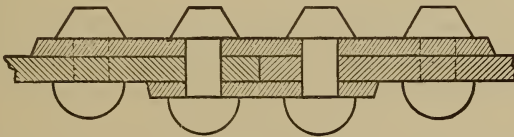

Fig. 18.

7. The single lap joint with cover plate, as shown in Fig. 19, is to have pitch of outer rivets double that of inner row. De-

termine diameter and pitch of rivets for $\frac{3}{8}$ inch plate and the efficiency of joint.

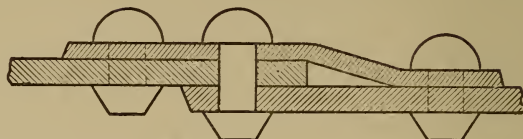

Fig. 19.

27. Riveted Joints for Narrow Plates. The joints which have been so far described are continuous and but one strip of a width equal to the pitch or the least common multiple of several pitches, has been investigated.

When narrow plates such as are used in structural work are to be joined by rivets, the joint is designed as a whole. Diamond riveting similar to that shown in Fig. 17 is generally used and the joint may be a lap, or a butt with double straps. The diameter of rivets may be taken about 1.5 times the thickness of plate [see equation (41)], and enough rivets used so that the total shearing strength may equal the tensile strength of the plate at the point of the diamond, where there is one rivet hole. It may be necessary to put in more rivets of a less diameter in order to make the figure symmetrical.

The efficiency of the joint may be tested at the different rows of rivets, allowing for tension of plate and shear of rivets in each case.

PROBLEMS.

1. Design a diamond-riveted lap-joint for a plate ten inches wide and one-half inch thick, and calculate least efficiency for shear and tension.

2. A diamond-riveted butt-joint with two straps has rivets arranged as in Fig. 20, the plate being twelve inches wide and three-quarter inches thick, and the rivets being one inch in diameter. If the plate and rivets are of steel, find the probable ultimate strength of the following parts :

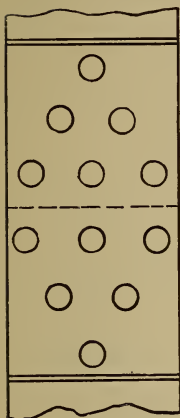

Fig. 20.

- (a) The whole plate.
- (b) All the rivets on one side of the joint.
- (c) The joint at the point of the diamond.
- (d) The joint at the row of rivets next the point.

28. Joint Pins. A joint pin is a bolt exposed to double shear. If the pin is loose in its bearings it should be designed with allowance for bending, by adding from 30 to 50 per cent to the area of cross-section needed to resist shearing alone. Bending of the pin also tends to spread apart the bearings and this should be prevented by having a head and nut or cotter on the pin.

If the pin is used to connect a knuckle joint as in boiler stays, the eyes forming the joint should have a net area 50 per cent in excess of the body of the stay, to allow for bending and uneven tension, (see Eye-bolts, Art. 20.)

Fig. 21 shows a pin and angle joint for attaching the end of a boiler stay to the head of the boiler.

29. Cotters. A cotter is a key which passes diametrically through a hub and its rod or shaft, to fasten

them together, and is so called to distinguish it from shafting keys which lie parallel to axis of shaft.

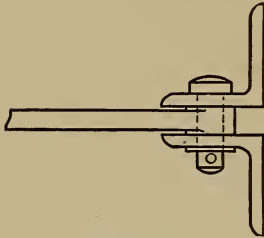

Fig. 21.

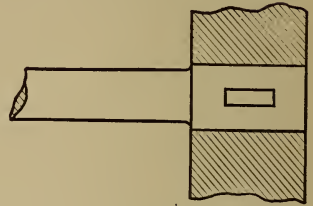

Fig. 22.

Its taper should not be more than 4 degrees or about 1 in 15, unless it is secured by a screw or check nut.

The rod is sometimes enlarged where it goes in the hub, so that the effective area of cross-section where the cotter goes through may be the same as in the body of the rod. (See Fig. 22.)

Let: d = diameter of body of rod.

d_1 = diameter of enlarged portion.

t = thickness of cotter, usually $= \frac{d_1}{4}$

b = breadth of cotter.

l = length of rod beyond cotter.

Suppose that the applied force is a pull on the rod—causing tension on the rod and shearing stress on the cotter.

The effective area of cross section of rod at cotter is

$$\frac{\pi d_1^2}{4} - \frac{d_1^2}{4} = (\pi - 1) \frac{d_1^2}{4}$$

and this should equal the area of cross-section of the body of rod.

$$(\pi-1)\frac{d_1^2}{4}=\frac{\pi d^2}{4}$$

$$d_1=d\sqrt{\frac{\pi}{\pi-1}}=1.21d. \quad \dots \dots \dots (44)$$

Let P =pull on rod.

S =shearing strength of material.

The area to resist shearing of cotter is

$$2bt=\frac{bd_1}{2}=\frac{P}{S}$$

$$\therefore b=\frac{2P}{d_1S} \quad \dots \dots \dots (a)$$

The area to resist shearing of rod is

$$2d_1l=\frac{P}{S}$$

and $l=\frac{P}{2d_1S} \quad \dots \dots \dots (b)$

If the metal of rod and cotter are the same

$$2d_1l=\frac{bd_1}{2}$$

$$l=\frac{b}{4} \quad \dots \dots \dots (45)$$

Great care should be taken in fitting cotters that they may not bear on corners of hole and thus tear the rod in two.

A cotter or pin subjected to alternate stresses in opposite directions should have a factor of safety double that otherwise allowed.

Adjustable cotters, used for tightening joints of bearings are usually accompanied by a gib having a

taper equal and opposite to that of the cotter. (Fig. 23). In designing these for strength the two can be regarded as resisting shear together.

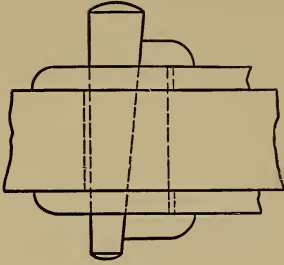

Fig. 23.

For shafting keys see chapter on shafting.

The split pin is in the nature of a cotter but is not usually expected to take any shearing stress.

PROBLEMS.

1. Design an angle joint for a soft steel boiler stay, the pull on stay being 12000 lbs. and the factor of safety, six. Use two standard angles.

2. Determine the diameter of a round cotter pin for equal strength of rod and pin.

3. A rod of wrought iron has keyed to it a piston 18 inches in diameter, by a cotter of machinery steel.

Required the two diameters of rod and dimensions of cotter to sustain a pressure of 150 pounds per square inch on the piston. Factor of safety = 8.

Design a cotter and gib for connecting rod of engine mentioned in Prob. 3, both to be of machinery steel and .75 inches thick. (See Fig. 23.)

CHAPTER V.

SPRINGS.

30. Helical Springs. The most common form of spring used in machinery is the spiral or helical spring made of round brass or steel wire. Such springs may be used to resist extension or compression or they may be used to resist a twisting moment.

Tension and Compression.

Let L = length of axis of spring.

D = mean diameter of spring.

l = developed length of wire.

d = diameter of wire.

R = ratio $\frac{D}{d}$.

n = number of coils.

P = tensile or compressive force.

x = corresponding extension or compression.

S = safe torsional or shearing strength of wire.

= 45000 to 60000 for spring brass wire.

= 75000 to 115000 for cast steel tempered.

G = modulus of torsional elasticity.

= 6000000 for spring brass wire.

= 12000000 to 15000000 for cast steel, tempered.

Then $l = \sqrt{\pi^2 D^2 n^2 + L^2}$

If the spring were extended until the wire became

straight it would then be twisted n times, or through an angle $=2\pi n$ and the stretch would be $l-L$.

The angle of torsion for a stretch $=x$ is then

$$\theta = \frac{2\pi n x}{l-L} \dots \dots \dots (a)$$

Suppose that a force P' acting at a radius $\frac{D}{2}$ will twist this same piece of wire through an angle θ causing a stress S at the surface of the wire. Then will the distortion of the surface of the wire per inch of length

be $s = \frac{\theta d}{2l}$ and the stress $S = \frac{5.1T}{d^3} = \frac{5.1P'D}{2d^3} \dots \dots (b)$

$$\therefore G = \frac{S}{s} = \frac{10.2P'Dl}{2d^4\theta} \dots \dots \dots (c)$$

In thus twisting the wire the force required will vary uniformly from 0 at the beginning to P' at the end provided the elastic limit is not passed, and the average force will be

$= \frac{P'}{2}$ The work done is therefore $\frac{P'D\theta}{4}$

If the wire is twisted through the same angle by the gradual application of the direct pressure P , compressing or extending the spring the amount x , the work done will be

$\frac{Px}{2}$ But $\frac{P'D\theta}{4} = \frac{Px}{2}$
 $\therefore P' = \frac{2Px}{D\theta} \dots \dots \dots (d)$

Substituting this value of P' in (c) and solving for x :

$$x = \frac{Gd^4\theta^2}{10.2Pl}$$

Substituting the value of θ from (a) and again solving for x :

$$x = \frac{10.2Pl}{Gd^4} \left\{ \frac{l-L}{2\pi n} \right\}^2 \dots \dots \dots (e)$$

If we neglect the original obliquity of the wire then $l = \pi Dn$ and $L = 0$ and equation (e) reduces to

$$x = \frac{2.55PLD^2}{Gd^4} \dots \dots \dots (46)$$

Making the same approximation in equation (d) we have

$$P' = P$$

i.e.—a force P will twist the wire through approximately the same angle when applied to extend or compress the spring, as if applied directly to twist a piece of straight wire of the same material with a lever

$$\text{arm} = \frac{D}{2}$$

This may be easily shown by a model.

The safe working load may be found by solving for P' in (b) and remembering that $P = P'$

$$P = \frac{Sd^3}{2.55D} = \frac{Sd^2}{2.55R} \dots \dots \dots (47)$$

when S is the safe shearing strength.

Substituting this value of P in (32) we have for the safe deflection:

$$x = \frac{IDS}{Gd} = \frac{IRS}{G} \dots \dots \dots (48)$$

31. Square Wire. The value of the stress for a square section is:

$$S = \frac{4.24T}{d^3}$$

where d is the side of square.

The distortion at the corners caused by twisting through an angle θ is :

$$s = \frac{\theta d}{l\sqrt{2}}$$

Equation (c) then becomes :

$$G = \frac{6P'Dl}{2d^4\theta}$$

The three principal equations (46), (47) and (48) then reduce to :

$$x = \frac{1.5PID^2}{Gd^4} \quad \cdot \quad \cdot \quad \cdot \quad \cdot \quad \cdot \quad \cdot \quad (49)$$

$$P = \frac{Sd^3}{2.12D} \quad \cdot \quad \cdot \quad \cdot \quad \cdot \quad \cdot \quad \cdot \quad (50)$$

$$x = \frac{lDS}{Gd\sqrt{2}} \quad \cdot \quad \cdot \quad \cdot \quad \cdot \quad \cdot \quad \cdot \quad (51)$$

The square section is not so economical of material as the round.

32. Experiments. Tests made on about 1700 tempered steel springs at the French Spring Works in Pittsburg were reported in 1901 by Mr. R. A. French.* These were all compression springs of round steel and were given a permanent set before testing by being closed coil to coil several times. Table XVIII gives results of these experiments.

* Trans. A. S. M. E., Vol. XXIII.

TABLE XVIII.

Group.	Number of Springs.	Outside Diameter.	Mean Diameter.	Diameter of Bar.	Ratio = $\frac{D}{d}$	Length of Bar.	Height before Closing.	Height after Closing.	Permanent Set = $H - H'$.	H''	Height when Closed.	Total Action = $H - H''$.	Ratio = $\frac{x}{s}$.	Load to Close Spring.	Coefficient of Torsional Elasticity.	Torsional or Shearing Stress.
	N	O	D	p	R	L	H	H'	S	H''	x	Y	P	G	S	
1	15	6	7	1.18125	9	180	17.25	15.25	2	8.8175	6.432	.311	10,900	12,000,000	97,500	
2	20	6	5.375	1.25	4.3	80	7.125	7.5	.125	5.9375	1.002	.117	6,375	14,400,000	44,700	
3	12	6	4.75	1.25	3.8	67	7.875	7.5	.375	5.875	1.625	.23	16,600	16,150,000	103,000	
4	6	5	4.125	1.125	3.67	89	10.75	10.125	.625	7.625	2.5	.25	13,800	13,400,000	102,000	
5	20	4	3.625	1.125	3.23	75	9.875	9.875	.5	7.25	2.125	.235	17,000	12,500,000	110,000	
6	40	7	6.625	1.125	5.9	100	7.875	6.625	.25	5.5	2.125	.117	4,850	15,800,000	57,500	
7	36	5	3.9375	1.0625	3.7	61	7.5	7.5	.5625	5.875	1.567	.36	12,000	14,400,000	100,000	
8	64	5.5	4.4375	1.0625	4.18	101	11.125	10.6875	.437	7.625	3.062	.142	12,000	16,100,000	113,000	
9	24	4.375	3.8125	1.0625	3.1	48	6.5	6.125	.375	5	1.125	.333	14,800	13,700,000	104,000	
10	6	6	5	1	5	84	8.625	8.125	.5	5.625	2.5	.2	8,000	17,100,000	102,000	
11	20	4.5	3.5	1	3.5	79	9.875	9.4375	.437	7.25	2.187	.201	12,500	14,100,000	111,800	
12	16	4.25	3.25	1	3.25	49	6.5	6.125	.375	4.875	1.25	.3	13,100	13,800,000	109,000	
13	36	4.75	3.75	1	3.75	37	4.5	4.125	.375	3.25	.875	.43	12,000	18,100,000	114,400	
14	35	4.187	3.25	.9375	3.45	50	6.3	6	.5	4.475	1.25	.40	10,500	14,700,000	106,000	
15	800	4.5	3.625	.875	4.15	57	6.375	6	.375	4.4375	1.562	.24	6,250	13,100,000	86,500	
16	8	3.75	2.875	.875	3.28	41	5.375	5	.375	4.125	1.875	.43	10,800	18,100,000	118,000	
17	24	4	3.125	.875	3.58	60	7.375	7	.375	5.4375	1.562	.24	8,650	13,900,000	103,000	
18	40	4	3.125	.875	3.58	51	6.5	6	.5	4.625	1.375	.364	12,000	18,900,000	143,000	
19	24	3.875	2.625	.75	3.5	62	7.25	7	.25	5.655	1.345	.186	5,250	13,500,000	83,500	
20	8	5.75	5	.75	6.67	172	17.625	16	1.625	8.4375	7.562	.212	2,850	13,100,000	86,500	
21	8	4.5	3.75	.75	5	84	8.5	8	.5	5.5	2.5	.20	4,000	15,200,000	91,000	
22	12	3.5	2.75	.75	3.67	53	6.375	6	.375	4.625	1.375	.273	6,950	16,200,000	115,000	
23	4	4	3.25	.75	4.33	44.5	5.75	4.6875	1.0625	3.0625	1.625	.655	6,500	15,400,000	127,000	
24	24	3.5	2.875	.625	4.6	68	7.375	7	.375	4.6875	2.312	.162	3,250	13,600,000	97,500	
25	100	3.25	2.625	.625	4.2	37.5	4.375	4	.375	2.8125	1.187	.316	4,225	15,500,000	116,500	
26	100	3.25	2.625	.625	4.2	43	4.75	4.5625	.187	3.375	1.187	.158	4,000	16,700,000	109,500	
27	200	3.5	3	.5	6	108	9.75	9.625	.125	5.8125	3.812	.032	1,250	12,900,000	76,500	

The apparent variation of G in the experiments is probably due to differences in the quality of steel and to the fact that the formula for G in the case of helical springs is an approximate one.

The same may be said of the values of S , but if these values are used in designing similar springs one error will off-set the other.

In some few cases, as in No. 18, it was necessary to use an abnormally high value of S to meet the conditions. This necessitated a special grade of steel, and great care in manufacture. Such a spring is not safe when subjected to sudden and heavy loads, or to rapid vibrations, as it would soon break under such treatment; if merely subjected to normal stress, it would last for years.

Springs of a small diameter may safely be subjected to a higher stress than those of a larger diameter, the size of bar being the same. The safe variation of S with R cannot yet be stated.

There is an important limit which should be here mentioned. Springs having too small a diameter as compared with size of bar are subjected to so much internal stress in coiling as to weaken the steel. A spring, to give good service, should never have R less than 3.

The size of bar has much to do with the safe value of S ; the probable explanation is this: A large bar has to be heated to a higher temperature in working it, and in high carbon steel this may cause deterioration; when tempered, the bath does not affect it so uniformly, as may be seen by examining the fracture of a large bar.

The above facts must always be taken into consideration in designing a spring, whatever the grade of

steel used. A safe value of S can be determined only by one having an accurate knowledge of the physical characteristics of the steel, the proportions of the spring, and the conditions of use.

7. For a good grade of steel the following values of S have been found safe under ordinary conditions of service, the value of G being taken as 14,500,000.

VALUES OF S .

	$R=3$	$R=8$
$d=\frac{3}{8}$ inch or less.....	112,000	85,000
$d=\frac{1}{16}$ inch to $\frac{3}{4}$ inch....	110,000	80,000
$d=\frac{1}{2}$ inch to $1\frac{1}{4}$ inch.....	105,000	75,000

For bars over $1\frac{1}{4}$ inches in diameter a stress of more than 100,000 should not be used. Where a spring is subjected to sudden shocks a smaller value of S is necessary.

As has been noted, the springs referred to in this paper were all compression springs. Experience has shown that in close coil or extension springs the value of G is the same, but that the safe value of S is only about two-thirds that for a compression spring of the same dimensions.

33. Spring in Torsion. If a helical spring is used to resist torsion instead of tension or compression, the wire itself is subjected to a bending moment. We will use the same notation as in the last article, only that P will be taken as a force acting tangentially to the circumference of the spring at a distance $\frac{D}{2}$ from the

axis, and S will now be the safe transverse strength of the wire, having the following values :

$$S = 60,000 \text{ for spring brass wire.}$$

$$= 90,000 \text{ to } 125,000 \text{ for cast steel tempered.}$$

$$E = 9000000 \text{ for spring brass wire.}$$

$$= 30000000 \text{ for cast steel tempered.}$$

Let θ = angle through which the spring is turned by P .

The bending moment on the wire will be the same throughout and $= \frac{PD}{2}$. This is best illustrated by a model.

To entirely straighten the wire by unwinding the spring would require the same force as to bend straight wire to the curvature of the helix.

To simplify the equations we will disregard the obliquity of the helix, then will $l = \pi Dn$ and the radius

of curvature $= \frac{D}{2}$.

Let M = bending moment caused by entirely straightening the wire ; then by mechanics

$$M = \frac{EI}{R} = \frac{2EI}{D}$$

and the corresponding angle through which spring is turned is $2\pi n$.

But it is assumed that a force P with a radius $\frac{D}{2}$ turns the spring through an angle θ .

$$\begin{aligned} \therefore \frac{PD}{2} &= \frac{2EI}{D} \times \frac{\theta}{2\pi n} \\ &= \frac{EI\theta}{\pi Dn} = \frac{EI\theta}{l} \end{aligned}$$

Solving for θ :

$$\theta = \frac{PDI}{2EI} \dots \dots \dots (a)$$

and if wire is round

$$\theta = \frac{10.2PDI}{Ed^4} \dots \dots \dots (52)$$

The bending moment for round wire will be

$$\frac{PD}{2} = \frac{Sd^3}{10.2} \dots \dots \dots (53)$$

and this will also be the safe twisting moment that can be applied to the spring when S = working strength of wire. The safe angle of deflection is found by substituting this value of $\frac{PD}{2}$ in (52):

Reducing : $\theta = \frac{2LS}{Ed} \dots \dots \dots (54)$

34. Flat Springs. Ordinary flat springs of uniform rectangular cross-section can be treated as beams and their strength and deflection calculated by the usual formulas.

In such a spring the bending and the stress are greatest at some one point and the curvature is not uniform.

To correct this fault the spring is made of a constant depth but varying width.

If the spring is fixed at one end and loaded at the other the plan should be a triangle with the apex at loaded end. If it is supported at the two ends and loaded at the center, the plan should be two triangles with their bases together under the load forming a

rhombus. The deflection of such a spring is one and a half times that of a rectangular spring.

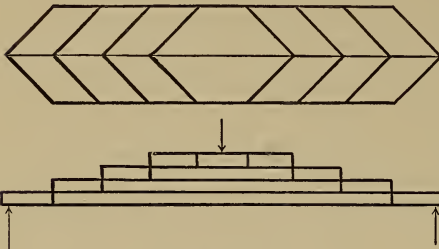

Fig. 24.

As such a spring might be of an inconvenient width, a compound or leaf-spring is made by cutting the triangular spring into strips parallel to the axis, and piling one above another as in Fig. 24.

This arrangement does not change the principle, save that the friction between the leaves may increase the resistance somewhat.

Let l = length of span.

b = breadth of leaves.

t = thickness of leaves.

n = number of leaves.

W = load at center.

Δ = deflection at center.

S and E may be taken as 80000 and 30000000 respectively.

Strength :

$$M = \frac{Wl}{4} = \frac{Snb t^2}{6}$$

$$W = \frac{2}{3} \cdot \frac{Snb t^2}{l} \dots \dots \dots (55)$$

Elasticity :

$$\Delta = \frac{Wl^3}{32EI} \text{ where } I = \frac{nb t^3}{12}$$

$$\dots \Delta = \frac{3Wl^3}{8Enbt^3} \dots \dots \dots (56)$$

35. **Elliptic and Semi-Elliptic Springs.** Springs as they are usually designed for service differ in some respects from those just described, as may be seen by reference to Fig. 25.

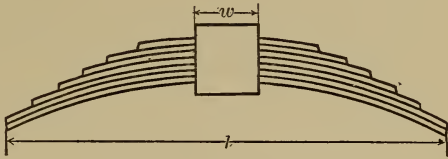

Fig. 25.

A band is used at the center to confine the leaves in place. As this band constrains the spring at the center it is best to consider the latter as made up of two cantilevers each having a length of $\frac{l-w}{2}$ where w is the width of band.

The spring usually contains several full-length leaves with blunt ends, the remaining leaves being graduated as to length and pointed as in Fig. 25. The blunt full-length leaves constitute cantilevers of uniform cross-section, while the graduated leaves form cantilevers of uniform strength. Under similar conditions as to load and fiber stress the latter will have a deflection fifty per cent greater than the former. Supposing that there is no initial stress between the leaves caused by the band, both sets must have the same deflection. This means that more than its proportion of the load will be carried by the full-length set and consequently it will have a greater fiber stress. This difficulty can be obviated by having an initial gap between the graduated set and the full-length set and closing this with the band.

If this gap is made half the working deflection of the spring, the total deflection of the graduated set under the working load will be fifty per cent greater than that of the full-length set and the fiber stress will be uniform.

The load will then be divided between the two sets in proportion to the number of leaves in each.

One of the full-length leaves must be counted as a part of the graduated set. When the gap is closed by a band there will be an initial pull on the band due to the deflection of the spring.

This can be determined for any given spring by regarding the two sets of leaves as simple beams the sum of whose deflections under the pull P is equal to the depth of the gap.

Full elliptic springs can be designed in a similar manner but the total deflection will be double that of the semi-elliptic spring.

PROBLEMS.

1. A spring balance is to weigh 25 pounds with an extension of 2 inches, the diameter of spring being $\frac{5}{8}$ inches and the material, tempered steel.

Determine the diameter and length of wire, and number of coils.

2. Determine the safe twisting moment and angle of torsion for the spring in example 1, if used for a torsional spring.

3. Test values of G and S from data given in Table XVIII.

4. By using above table design a spring 8 ins. long to carry a load of 2 tons without closing the coils more than half way.

5. Design a compound flat spring for a locomotive to sustain a load of 16000 lbs. at the center, the span being 40 inches, the number of leaves 12 and the material steel.

6. Determine the maximum deflection of the above spring, under the working load.

7. A semi-elliptic spring has N leaves in all and n graduated leaves, and the load on each end is $P = \frac{W}{2}$. Develop formulas for the fiber stress in each set of leaves if there is no initial stress.

8. In Prob. 7 develop a formula for the necessary gap to equalize the fiber stresses.

9. In Prob. 8 determine the pull on the band due to the initial stress.

10. A semi-elliptic spring has 4 leaves 36 inches long, and 12 graduated leaves. The leaves are all 4 inches wide and $\frac{3}{8}$ inches thick, and the band at the center is 4 inches wide. If there is no initial stress find the share of the load and the fiber stress on each set of leaves when there is a load of 6 tons on the center. Also determine deflection.

11. In Prob. 10, determine the amount of gap needed to equalize the stresses in the two sets of leaves, and the pull on the band at the center. Determine the deflection under the load.

12. Measure various indicator springs and determine value of G from rating of springs.

13. Measure various brass extension springs, calculate safe static load and safe stretch.

14. Make an experiment on torsion spring to determine distortion under a given load and calculate value of E .

CHAPTER VI.

SLIDING BEARINGS.

36. Slides in General. The surfaces of all slides should have sufficient area to limit the intensity of pressure and prevent forcing out of the lubricant. No general rule can be given for the limit of pressure. Tool marks parallel to the sliding motion should not be allowed, as they tend to start grooving. The sliding piece should be as long as practicable to avoid local wear on stationary piece and for the same reason should have sufficient stiffness to prevent springing. A slide which is in continuous motion should lap over the guides at the ends of stroke, to prevent the wearing of shoulders on the latter and the finished surfaces of all slides should have exactly the same width as the surfaces on which they move for a similar reason.

Where there are two parallel guides to motion as in a lathe or planer it is better to have but one of these depended upon as an accurate guide and to use the other merely as a support. It must be remembered that any sliding bearing is but a copy of the ways of the machine on which it was planed or ground and in turn may reproduce these same errors in other machines. The interposition of handscraping is the only cure for these hereditary complaints.

In designing a slide one must consider whether it is accuracy of motion that is sought, as in the ways of a planer or lathe, or accuracy of position as in the head

of a milling machine. Slides may be divided according to their shapes into angular, flat and circular slides.

37. Angular Slides. An angular slide is one in which the guiding surface is not normal to the direction of pressure. There is a tendency to displacement sideways, which necessitates a second guiding surface inclined to the first. This oblique pressure constitutes the principal disadvantage of angular slides. Their principal advantage is the fact that they are either self-adjusting for wear, as in the ways of lathes and planers, or require at most but one adjustment.

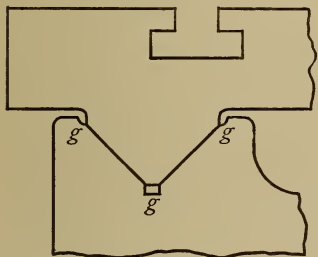

Fig. 26.

Fig. 26 shows one of the V's of an ordinary planing machine. The platen is held in place by gravity. The angle between the two surfaces is usually 90 deg. but may be more in heavy machines. The grooves *g, g* are intended to hold the oil in place; oiling is sometimes

effected by small rolls recessed into the lower piece and held against the platen by springs.

The principal advantage of this form of way is its ability to hold oil and the great disadvantage its faculty for catching chips and dirt.

Fig 27 shows an inverted V such as is common on the ways of engine lathes. The

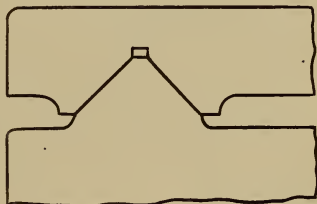

Fig. 27

angle is about the same as in the preceding form but

the top of the V should be rounded as a precaution against nicks and bruises.

The inverted V is preferred for lathes since it will not catch dirt and chips. It needs frequent lubrication as the oil runs off rapidly. Some lathe carriages are provided with extensions filled with oily felt or waste to protect the ways from dirt and keep them wiped and oiled. Side pressure tends to throw the carriage from the ways; this action may be prevented by a heavy weight hung on the carriage or by gibbing the carriage at the back. (See Fig. 33). The objection to this latter form of construction is the fact that it is practically impossible to make and keep the two V 's and the gibbed slide all parallel.



Fig. 28.

Fig. 28 shows a compound V sometimes used on heavy machines. The obtuse angle (about 150 deg.) takes the heavy vertical pressure, while the sides, inclined only 8 or 10 deg., take any side pressure which may

develop.

38. Gibbed Slides. All slides which are not self-adjusting for wear must be provided with gibs and adjusting screws. Fig. 29 shows the most common form as used in tool slides for lathes and planing machines.

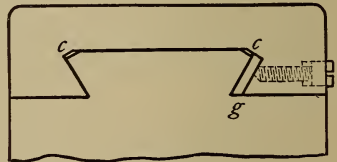

Fig. 29.

The angle employed is usually 60 deg.; notice that the corners $c c$ are clipped for strength and to avoid a

corner bearing ; notice also the shape of gib. It is better to have the points of screws coned to fit gib and *not* to have flat points fitting recesses in gib. The latter form tends to spread joint apart by forcing gib down. If the gib is too thin it will spring under the screws and cause uneven wear.

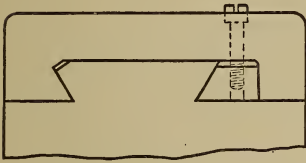

Fig. 30.

The cast iron gib, Fig. 30, is free from this latter defect but makes the slide rather clumsy. The screws however are more accessible in this form. Gibs are sometimes made slightly tapering and adjusted by a screw and nut giving endwise motion.

39. Flat Slides. This type of slide requires adjustment in two directions and is usually provided with gibs and adjusting screws. Flat ways on machine tools are the rule in English practice and are gradually coming into use in this country. Although more expensive at first and not so simple they are more durable and usually more accurate than the angular ways.

Fig. 31 illustrates a flat way for a planing machine. The other way would be similar to this but without adjustment. The normal pressure and the friction are less than with angular ways and no amount of side pressure will lift the platen from its position.

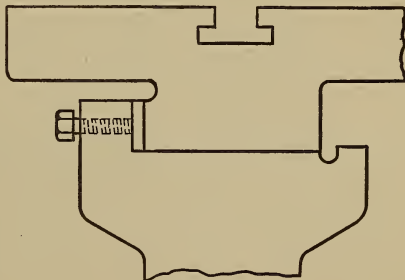

Fig. 31.

Fig. 32 shows a portion of the ram of a shaping machine and illustrates the use of an *L* gib for adjustment in two directions.

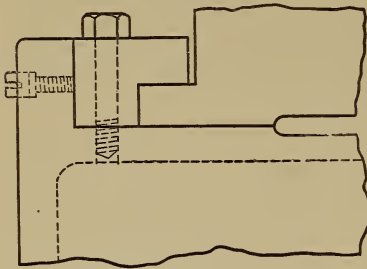

Fig. 32.

Fig. 33 shows a gibbed slide for holding down the back of a lathe carriage with two adjustments.

The gib *g* is tapered and adjusted by a screw and nuts. The saddle of a planing machine or

the table of a shaper usually has a rectangular gibbed

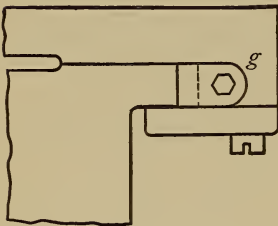

Fig. 33.



Fig. 34.

slide above and a taper slide below, this form of the upper slide being necessary to hold the weight of the overhanging metal. (See Fig. 34.) Some lathes and planers are built with one *V* or angular way for guiding the carriage of platen and one flat way acting merely as a support.

40. Circular Guides. Examples of this form may be found in the column of the drill press and the overhanging arm of the milling machine. The cross heads of steam engines are sometimes fitted with circular guides; they are more frequently flat or angular. One advantage of the circular form is the fact that the cross

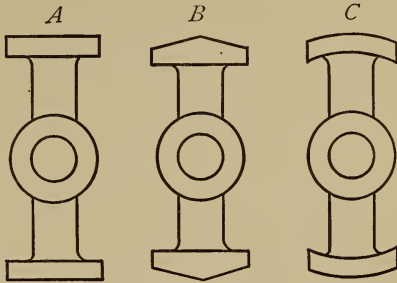

Fig. 35.

head can adjust itself to bring the wrist pin parallel to the crank pin. The guides can be bored at the same setting as the cylinder in small engines and thus secure good alignment.

Fig. 35 illustrates various shapes of cross head slides in common use.

41. Stuffing Boxes. In steam engines and pumps the glands for holding the steam and water packing are the sliding bearings which cause the greatest fric-

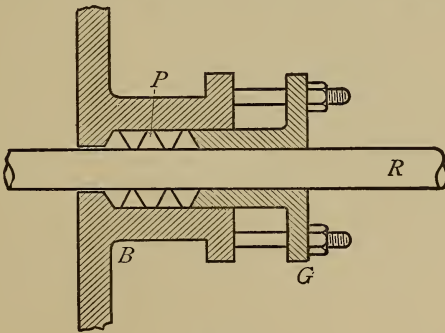

Fig. 36.

tion and the most trouble. Fig. 36 shows the general

arrangement. *B* is the stuffing box attached to the cylinder head; *R* is the piston rod; *G* the gland adjusted by nuts on the studs shown; *P* the packing contained in a recess in the box and consisting of rings, either of some elastic fibrous material like hemp and woven rubber cloth or of some soft metal like babbit. The pressure between the packing and the rod, necessary to prevent leakage of steam or water, is the cause of considerable friction and lost work. Experiments made from time to time in the laboratories of the Case School have shown the extent and manner of variation of this friction. The results for steam packings may be summarized as follows:

1. That the softer rubber and graphite packings, which are self-adjusting and self-lubricating, as in Nos. 2, 3, 7, 8, and 11, consume less power than the harder varieties. No. 17, the old braided flax style, gives very good results.

2. That oiling the rod will reduce the friction with any packing.

3. That there is almost no limit to the loss caused by the injudicious use of the monkey-wrench.

4. That the power loss varies almost directly with the steam pressure in the harder varieties, while it is approximately constant with the softer kinds.

The diameter of rod used—two inches—would be appropriate for engines from 50 to 100 horse-power. The piston speed was about 140 feet per minute in the experiments, and the horse-power varied from .036 to .400 at 50 pounds steam pressure, with a safe average for the softer class of packings of .07 horse-power.

At a piston speed of 600 feet per minute, the same friction would give a loss of from .154 to 1.71 with a

working average of .30 horse-power, at a mean steam pressure of 50 pounds.

In Table XIX Nos. 6, 14, 15 and 16 are square, hard rubber packings without lubricants.

Similar experiments on hydraulic packings under a water pressure varying from ten to eighty pounds per square inch gave results as shown in Table XXI.

The figures given are for a two inch rod running at an average piston speed of 140 feet per minute.

TABLE XIX.

Kind of Packing.	No Trials.	Total Time of Run in Minutes.	Av. Horse Power Consumed by each Box.	Horse Pow. Cons. at 50 Lbs. Press.	Remarks on Leakage, etc.
1	5	22	.091	.085	Moderate leakage.
2	8	40	.049	.048	Easily adjusted ; slight leakage.
3	5	25	.037	.036	Considerable leakage.
4	5	25	.159	.176	Leaked badly.
5	5	25	.095	.081	Oiling necessary ; leaked badly.
6	5	25	.368	.400	Moderate leakage.
7	5	25	.067	.067	Easily adjusted and no leakage.
8	5	25	.082	.082	Very satisfactory ; slight leakage.
9	3	15	.200	.182	Moderate leakage.
10	3	..	.275	..	Excessive leakage.
11	5	25	.157	.172	Moderate leakage.
12	5	25	.266	.330	Moderate leakage.
13	5	25	.162	.230	No leakage ; oiling necessary.
14	5	25	.176	.276	Moderate leakage ; oiling necessary.
15	5	25	.233	.255	Difficult to adjust ; no leakage.
16	5	25	.292	.210	Oiling necessary ; no leakage.
17	5	25	.128	.084	No leakage.

TABLE XX.

Kind of Packing.	Horse Power consumed by each Box, when Pressure was applied to Gland Nuts by a Seven-Inch Wrench.						Horse Power before and after oiling Rod.	
	5 Pounds.	8 Pounds.	10 Pounds.	12 Pounds.	14 Pounds.	16 Pounds.	Dry.	Oiled.
1	.120136
3055	.021
4248303390	.154	.123
5220
6348	.430323	.194
7126	.228	.260	.330	.340	.067	.053
8363	.500	.535	.520	.533	.533	.236
9666666	.636
11405	.454454	.176
12161	.242	.359	.454454	.122
13317	.394	.582
15526
16327	.860
17198	.277	.380

TABLE XXI.

No. of Packing.	Av. H. P. at 20 lbs.	Av. H. P. at 70 Lbs.	Max. H. P.	Min. H. P.	Av. H. P. for entire Test.
1	.077	.351	.452	.024	.259
2	.422	.500	.512	.167	.410
3	.130	.178	.276	.035	.120
4	.184	.195	.230	.142	.188
5	.146	.162	.285	.069	.158
6	.240	.200	.255	.071	.186
7	.127	.192	.213	.095	.154
8	.153	.174	.238	.112	.165
9	.287	.469	.535	.159	.389
10	.151	.160	.226	.035	.103
11	.141	.156	.380	.064	.177
12	.053	.095	.143	.035	.090

Packings Nos. 5, 6, 10 and 12 are braided flax with graphite lubrication and are best adapted for low pressures. Packings Nos. 3, 4 and 7 are similar to the above but have paraffine lubrication. Packings Nos. 2 and 9 are square duck without lubricant and are only suitable for very high pressures, the friction loss being approximately constant.

PROBLEMS.

Make a careful study and sketch of the sliding bearings on each of the following machines and analyze as to (a) Purpose (b) Character. (c) Adjustment. (d) Lubrication.

1. An engine lathe.
2. A planing machine.
3. A shaping machine.
4. A milling machine.
5. An upright drill.
6. A Corliss engine.
7. A Porter-Allen engine.
8. A gas-engine.
9. An air-compressor.

CHAPTER VII.

JOURNALS, PIVOTS AND BEARINGS.

42. Journals. A journal is that part of a rotating shaft which rests in the bearings and is of necessity a surface of revolution, usually cylindrical or conical. The material of the journal is generally steel, sometimes soft and sometimes hardened and ground.

The material of the bearing should be softer than the journal and of such a quality as to hold oil readily. The cast metals such as cast iron, bronze and babbitt metal are suitable on account of their porous, granular character. Wood, having the grain normal to the bearing surface, is used where water is the lubricant, as in water wheel steps and stern bearings of propellers.

43. Adjustment. Bearings wear more or less rapidly with use and need to be adjusted to compensate for the wear. The adjustment must be of such a character and in such a direction as to take up the wear and at the same time maintain as far as possible the correct shape of the bearing. The adjustment should then be in the line of the greatest pressure.

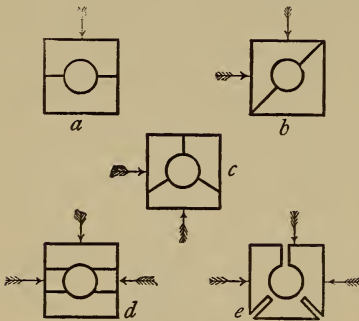

Fig. 37.

Fig. 37 illustrates some of the more common ways of adjusting a bearing, the

arrows showing the direction of adjustment and presumably the direction of pressure ; (a) is the most usual where the principal wear is vertical, (d) is a form frequently used on the main journals of engines when the wear is in two directions, horizontal on account of the steam pressure and vertical on account of the weight of shaft and fly wheel. All of these are more or less imperfect since the bearing, after wear and adjustment, is no longer cylindrical but is made up of two or more approximately cylindrical surfaces.

A bearing slightly conical and adjusted endwise as it wears, is probably the closest approximation to correct practice.

Fig. 38 shows the main bearing of the Porter - Allen engine, one of the best examples of a four part adjustment.

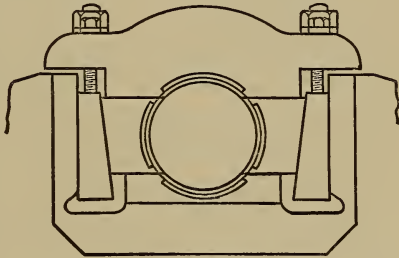

Fig. 38.

The cap, is adjusted in the normal way with bolts and nuts ; the bottom, can be raised and lowered by liners placed underneath ; the cheeks can be moved in or out by means of the wedges shown. Thus it is possible, not only to adjust the bearing for wear, but to align the shaft perfectly.

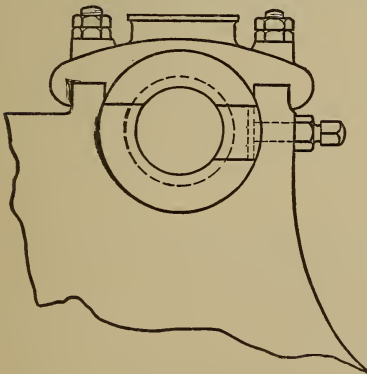

Fig. 39.

A three part bearing

for the main journal of an engine is shown in Fig. 39. In this bearing there is one horizontal adjustment, instead of two as in Fig. 38.

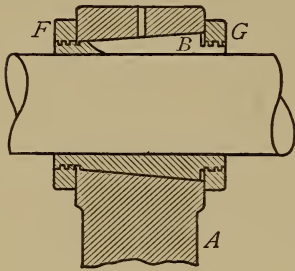

Fig. 40.

The main bearing of the spindle in a lathe, as shown in Fig. 40, offers a good example of symmetrical adjustment. The headstock A has a conical hole to receive the bearing B, which latter can be moved lengthwise by the nuts F G. The bearing may be split into two, three or four segments or it may be cut as shown in (e)

Fig. 37, and sprung into adjustment. A careful distinction must be made between this class of bearing and that before mentioned, where the journal itself is conical and adjusted endwise. A good example of the latter form is seen in the spindles of many milling machines.

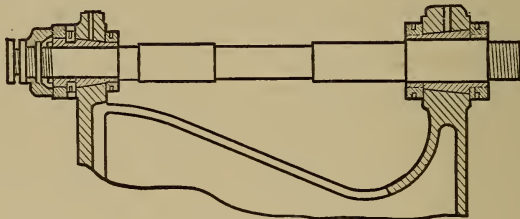

Fig. 41.

Fig. 41 shows the spindle of an engine lathe complete with its two bearings. The end thrust is taken by a fiber washer backed by an adjusting collar and check nut. Both bearings belong to the class shown in Fig. 40.

A conical journal with end adjustment is illustrated

in Fig. 42, which shows the spindle of a milling machine. The front journal is conical and is adjusted

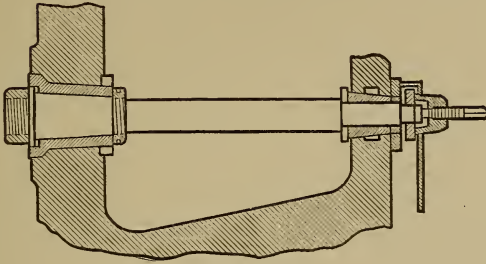

Fig. 42.

for wear by drawing it back into its bearing with the nut. The rear journal on the other hand is cylindrical and its bearing is adjusted as are those just described. The end thrust is taken by two loose rings at the front end of the spindle.

44. Lubrication. The bearings of machines which run intermittently, like most machine tools, are oiled by means of simple oil holes, but machinery which is in continuous motion as is the case with line shafting and engines requires some automatic system of lubrication. There is not space in this book for a detailed description of all the various types of oiling devices and only a general classification will be attempted.

Lubrication is effected in the following ways :

1. By grease cups,
2. By oil cups.
3. By oily pads of felt or waste.
4. By oil wells with rings or chains for lifting the oil.
5. By centrifugal force through a hole in the journal itself.

Grease cups have little to recommend them except

as auxiliary safety devices. Oil cups are various in their shapes and methods of operation and constitute the cheap class of lubricating devices. They may be divided according to their operation into wick oilers, needle feed, and sight feed. The two first mentioned are nearly obsolete and the sight feed oil cup, which drops the oil at regular intervals through a glass tube in plain sight, is in common use. The best sight feed oiler is that which can be readily adjusted as to time intervals, which can be turned on or off without disturbing the adjustment and which shows clearly by its appearance whether it is turned on. On engines and electric machinery which is in continuous use day and night, it is very important that the oiler itself should be stationary, so that it may be filled without stopping the machinery.

A modern sight feed oiler for an engine is illustrated in Fig. 43. T is the glass tube where the oil drop is seen. The feed is regulated by the nut N , while the lever L shuts off the oil. Where the lever is as shown the oil is dropping, when horizontal the oil is shut off.

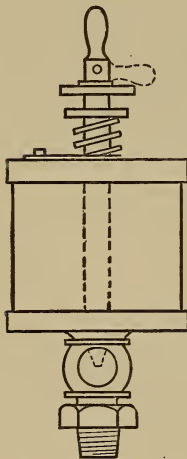

Fig 43.

The nut can be adjusted once for all, and the position of the lever shows immediately whether or not the cup is in use.

In modern engines particular attention has been paid to the problem of continuous oiling. The oil cups are all stationary and various ingenious devices are used for catching the drops of oil from the cups and distributing them to the bearing surfaces.

For continuous oiling of stationary bearings as in line shafting and electric machinery, an oil well below the bearing is preferred, with some automatic means of pumping the oil over the bearing, when it runs back by gravity into the well. Porous wicks and pads acting by capillary attraction are uncertain in their action and liable to become clogged. For bearings of medium size, one or more light steel rings running loose on the shaft and dipping into the oil, as shown in Fig. 44, are the best. For large bearings flexible chains are employed which take up less room than the ring. Centrifugal oilers are most used on parts which cannot readily be oiled when in motion, such as loose pulleys and the crank pins of engines.

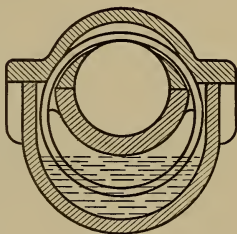

Fig. 44.

Fig. 45 shows two such devices as applied to an engine. In *A* the oil is supplied by the waste from the main journal; in *B* an external sight-feed oil cup is used which supplies oil to the central revolving cup *C*.

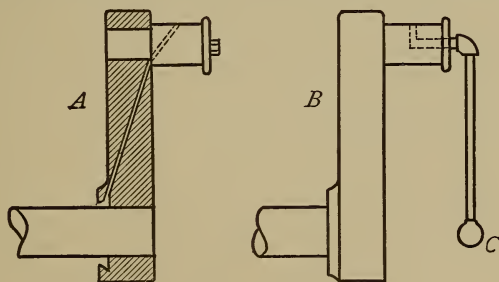

Fig. 45.

Loose pulleys or pulleys running on stationary studs are best oiled from a hole running along the axis

of the shaft and thence out radially to the surface of the bearing. See Fig 46. A loose bushing of some soft metal perforated with holes is a good safety device for loose pulleys.

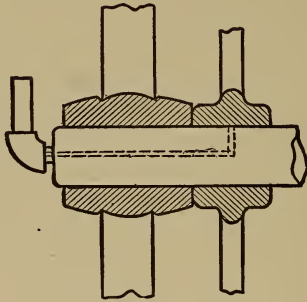

Fig. 46.

Note : For adjustable pedestal and hanging bearings see the chapter on shafting.

45: Friction of Journals :

Let W = the total load of a journal in lbs.

l = the length of journal in inches.

d = the diameter of journal in inches.

N = number of revolutions per minute.

v = velocity of rubbing in feet per minute.

F = friction at surface of journal in lbs.

= $W \tan \psi$ nearly, whose ψ is the angle of re-

pose for the two materials.

If a journal is properly fitted in its bearing and does not bind, the value of F will not exceed $W \tan \psi$ and may be slightly less. The value of $\tan \psi$ varies according to the materials used and the kind of lubrication, from .05 to .01 or even less. See experiments described in Art. 48. The work absorbed in friction may be thus expressed :

$$Fv = W \tan \psi \times \frac{\pi d N}{12} = \frac{\pi d N W \tan \psi}{12} \text{ ft. lbs. per min. (57)}$$

46. **Limits of Pressure.** Too great an intensity of pressure between the surface of a journal and its bearing will force out the lubricant and cause heating and possibly "seizing." The safe limit of pressure depends on the kind of lubricant, the manner of its application and upon whether the pressure is continuous or intermittent. The projected area of a journal, or the product of its length by its diameter, is used as a divisor.

The journals of railway cars offer a good example of continuous pressure and severe service. A limit of 300 pounds per square inch of projected area has been generally adopted in such cases.

In the crank and wrist pins of engines, the reversal of pressure diminishes the chances of the lubricant being squeezed out, and a pressure of 500 lbs. per sq. in. is generally allowed.

The use of heavy oils or of an oil bath, and the employment of harder materials for the journal and its bearing allow of even greater pressures.

Professor Barr's investigations of steam engine proportions * show that the pressure per square inch on the cross-head pin varies from ten to twenty times that on the piston, while the intensity of pressure on the crank pin is from two to eight times that on the piston. Allowing a mean pressure on the piston of fifty pounds per square inch would give the following range of pressures :

	Minimum.	Maximum.
Wrist pins. . . .	500	1000
Crank pins. . . .	100	400

The larger values for the wrist pins are allowable on

* Trans. A. S. M. E., Vol. XVIII.

account of the comparatively low velocity of rubbing. Naturally the larger values for the pressure are found in the low speed engines.

A discussion of the subject of bearings is reported in the transactions of the American Society of Mechanical Engineers for 1905-06 * and some valuable data are furnished. Mr. Geo. M. Basford says that locomotive crank pins have been loaded as high as 1500 to 1700 pounds per square inch, and wrist pins to 4000 pounds per square inch.

Locomotive driving journals on the other hand are limited to the following pressures :

Passenger locomotives	.	190	lbs. per sq. in.
Freight	"	200	" "
Switching	"	220	" "
Cars and tender bearings.		300	" "

Mr. H. G. Reist gives some figures on the practice of the General Electric Company, for motors and generators.

This company allows from 30 to 80 pounds pressure per square inch with an average value of from 40 to 45 pounds. The rubbing speeds vary from 40 feet to 1200 feet per minute. Mr. Reist quotes approvingly the formula of Dr. Thurston's, viz : That the product of the pressure in pounds per square inch and the rubbing speed in feet per minute should not exceed 50,000.

A careful reading of the whole discussion will repay any one who has to design shaft bearings of any description.

47. Heating of Journals. The proper length of journals depends on the liability of heating.

* Trans. A. S. M. E., Vol. XXVII.

The energy or work expended in overcoming friction is converted into heat and must be conveyed away by the material of the rubbing surfaces. If the ratio of this energy to the area of the surface exceeds a certain limit, depending on circumstances, the heat will not be conveyed away with sufficient rapidity and the bearing will heat.

The area of the rubbing surface is proportional to the projected area or product of the length and diameter of the journal, and it is this latter area which is used in calculation.

Adopting the same notation as is used in Art. 45, we have from equation (57).

$$\text{the work of friction} = \frac{\pi d N W t \tan \psi}{12} \text{ ft. lbs. per min.}$$

$$\text{or} = \pi d N W t \tan \psi \text{ inch lbs.}$$

The work per square inch of projected area is then :

$$w = \frac{\pi d N W t \tan \psi}{l d} = \frac{\pi N W t \tan \psi}{l} \quad . \quad . \quad . \quad . \quad (a)$$

Solving in (a) for l

$$l = \frac{\pi N W t \tan \psi}{w} \quad . \quad . \quad . \quad . \quad (b)$$

Let $\frac{w}{\pi \tan \psi} = C$ a co-efficient whose value is to be obtained by experiment ; then

$$C = \frac{W N}{l} \text{ and } l = \frac{W N}{C} \quad . \quad . \quad . \quad (58)$$

Crank pins of steam engines have perhaps caused more trouble by heating than any other form of journal. A comparison of eight different classes of propellers in the old U. S. Navy showed an average value for C of 350,000.

Compare these formulas with (58) when values of C are introduced.

In a discussion on the subject of journal bearings in 1885,* Mr. Geo. H. Babcock said that he had found it practicable to allow as high as 1200 lb. per sq. in. on crank pins while the main journal could not carry over 300 lb. per sq. in. without heating. One rule for speed and pressure of journal bearings used by a well-known designer of Corliss engines is to multiply the square root of the speed in feet per second by the pressure per square inch of projected area and limit this product to 350 for horizontal engines and 500 in vertical engines.

48. Experiments. Some tests made on a steel journal $3\frac{1}{4}$ inches in diameter and 8 inches long running in a cast-iron bearing and lubricated by a sight-feed oiler, will serve to illustrate the friction and heating of such journals.

The two halves of the bearing were forced together by helical springs with a total force of 1400 pounds, so that there was a pressure of 54 lb. per sq. in. on each half. The surface speed was 430 ft. per min. and the oil was fed at the rate of about 12 drops per minute. The lubricant used was a rather heavy automobile oil having a specific gravity of 0.925 and a viscosity of 174 when compared with water at 20 deg. Cent.

The length of the run was two hours and the temperature of the room 70 deg. Fahr. (See Table XXII.)

* Trans. A. S. M. E., Vol. VI.

TABLE XXII.

FRICITION OF JOURNAL BEARING.

Time.	Rev. per min.	Temp. Fahr.	Coeff. of friction.
10 : 03	500	69	.024
10 : 15	482	82	.0175
10 : 30	506	100	.013
10 : 45	506	115	.010
11 : 00	516	125	.010
11 : 15	135	.004
11 : 30	145	.004
11 : 45	512	147	.004
12 : 00	151	.007

49. Strength and Stiffness of Journals. A journal is usually in the condition of a bracket with a uniform load, and the bending moment $M = \frac{Wl}{2}$

Therefore by formula (6)

$$d = \sqrt[3]{\frac{10.2M}{S}} = \sqrt[3]{\frac{5.1Wl}{S}}$$

$$\text{or } d = 1.721 \sqrt[3]{\frac{Wl}{S}} \dots \dots \dots (62)$$

The maximum deflection of such a bracket is

$$\Delta = \frac{Wl^3}{8E I}$$

$$I = \frac{\pi d^4}{64} = \frac{Wl^3}{8E\Delta}$$

$$d^4 = \frac{64Wl^3}{8\pi E\Delta} = \frac{2.547Wl^3}{E\Delta}$$

If as is usual Δ is allowed to be $\frac{1}{100}$ inches, then for stiffness

$$d = \sqrt[4]{\frac{254.7Wl^3}{E}} \dots \dots \dots (63)$$

or approximately $d = 4 \sqrt[4]{\frac{Wl^3}{E}} \dots \dots \dots (64)$

The designer must be guided by circumstances in determining whether the journal shall be calculated for wear, for strength or for stiffness. A safe way is to design the journal by the formulas for heating and wear and then to test for strength and deflection.

Remember that no factor of safety is needed in formula for stiffness.

Note that W in formulas for strength and stiffness is not the average but the maximum load.

50. Caps and Bolts. The cap of a journal bearing exposed to upward pressure is in the condition of a beam supported by the holding down bolts and loaded at the center, and may be designed either for strength or for stiffness.

Let : P = max. upward pressure on cap.

L = distance between bolts.

b = breadth of cap at center.

h = depth of cap at center.

Δ = greatest allowable deflection.

$$\text{Strength : } M = \frac{Sbh^2}{6} = \frac{PL}{4}$$

$$h = \sqrt{\frac{3PL}{2bS}} \dots \dots \dots (65)$$

$$\text{Stiffness : } \Delta = \frac{WL^3}{48EI}$$

$$I = \frac{bh^3}{12} = \frac{WL^3}{48E\Delta}$$

$$h = \sqrt[3]{\frac{WL^3}{4bE\Delta}} \dots \dots \dots (66)$$

If Δ is allowed to be $\frac{1}{100}$ inches and E for cast iron is taken = 18000000

$$\text{then : } h = .01115L \sqrt[3]{\frac{W}{b}} \dots \dots \dots (67)$$

The holding down bolts should be so designed that the bolts on one side of the cap may be capable of carrying safely two thirds of the total pressure.

PROBLEMS.

1. A flat car weighs 10 tons, is designed to carry a load of 20 tons more and is supported by two four-wheeled trucks, the axle journals being of wrought iron and the wheels 33 inches in diameter.

Design the journals, considering heating, wear, strength and stiffness, assuming a maximum speed of 30 miles an hour, factor of safety=10 and $C=300000$.

2. The following dimensions are those generally used for the journals of freight cars having nominal capacities as indicated :

CAPACITY.		DIMENSIONS OF JOURNAL.	
100000 lb.	- - -	4.5	by 9 in.
60000 lb.	- - -	4.25	by 8 in.
40000 lb.	- - -	3.75	by 7 in.

Assuming the weight of the car to be 40 per cent of its carrying capacity in each instance, determine the pressure per square inch of projected area and the value of the constant C {Formula (58)}.

3. Measure the crank pin of any modern engine which is accessible, calculate the various constants and compare them with those given in this chapter.

4. Design a crank pin for an engine under the following conditions :

Diameter of piston	=28 inches.
Maximum steam pressure	=90 lb. per sq. in.
Mean steam pressure	=40 lb. per sq. in.
Revolutions per minute	=75

Determine dimensions necessary to prevent wear and heating and then test for strength and stiffness.

5. Design a crank pin for a high speed engine having the following dimensions and conditions :

Diameter of piston	=14 inches
--------------------	------------

Maximum steam pressure=100 lb. per sq. in.

Mean steam pressure =50 lb. per sq. in.

Revolutions per minute=250.

6. Make a careful study and sketch of journals and journal bearings on each of the following machines and analyze as to

(a) Materials. (b) Adjustment. (c) Lubrication.

a. An engine lathe.

b. A milling machine.

c. A steam engine.

d. An electric generator or motor.

7. Sketch at least two forms of oil cup used in the laboratories and explain their working.

8. The shaft journal of a vertical engine is 4 in. in diameter by 6 in. long. The cap is of cast iron, held down by 4 bolts of wrought iron, each 5 in. from center of shaft, and the greatest vertical pressure is 12000 lb.

Calculate depth of cap at center for both strength and stiffness, and also the diameter of bolts.

9. Investigate the strength of the cap and bolts of some pillow block whose dimensions are known, under a pressure of 500 lb. per sq. in. of projected area.

10. The total weight on the drivers of a locomotive is 64000 lb. The drivers are four in number, 5 ft. 2 in. in diameter, and have journals $7\frac{1}{2}$ in. in diameter.

Determine horse power consumed in friction when the locomotive is running 50 miles an hour, assuming $\tan\phi=.05$.

51. Step-Bearings. Any bearing which is designed to resist end thrust of the shaft rather than lateral pressure is denominated a step or thrust bearing. These are naturally most used on vertical shafts, but may be frequently seen on horizontal ones as for example on the spindles of engine lathes, boring machines and milling machines.

Step-bearings may be classified according to the shape of the rubbing surface, as flat pivots and collars, conical pivots, and conoidal pivots of which the Schiele

pivot is the best known. When a step-bearing on a vertical shaft is exposed to great pressure or speed it is sometimes lubricated by an oil tube coming up from below to the center of the bearing and connecting with a stand pipe or force-pump. The oil entering at the center is distributed by centrifugal force.

52. Friction of Pivots or Step-bearings. — Flat Pivots.

Let W = weight on pivot
 d_1 = outer diameter of pivot
 p = intensity of vertical pressure
 T = moment of friction
 f = co-efficient of friction = $\tan \phi$

We will assume p to be a constant which is no doubt approximately true.

$$\text{Then } p = \frac{W}{\text{area}} = \frac{4W}{\pi d_1^2}$$

Let r = the radius of any elementary ring of a width = dr ,
 then area of element = $2\pi r dr$
 Friction of element = $f p \times 2\pi r dr$
 Moment of friction of element = $2f p \pi r^2 dr$

and
$$T = 2f p \pi \int_0^{\frac{d_1}{2}} r^2 dr \quad . \quad . \quad . \quad . \quad (a)$$

$$\begin{aligned} \text{or } T &= 2f p \pi \frac{r^3}{3} = 2f p \pi \frac{d_1^3}{24} \\ &= \frac{2f \pi d_1^3}{24} \times \frac{4W}{\pi d_1^2} = \frac{1}{3} W f d_1 \quad . \quad . \quad (68) \end{aligned}$$

The great objection to this form of pivot is the uneven wear due to the difference in velocity between center and circumference.

53. Flat Collar.

Let d_2 = inside diameter

Integrating as in equation (a) above, but using

limits $\frac{d_1}{2}$ and $\frac{d_2}{2}$ we have

$$T = 2fp\pi \frac{d_1^3 - d_2^3}{24}$$

In this case

$$p = \frac{4W}{\pi(d_1^2 - d_2^2)}$$

and $T = \frac{1}{3}Wf \frac{d_1^3 - d_2^3}{d_1^2 - d_2^2} \dots \dots \dots (69)$

54. Conical Pivot.

Let α = angle of inclination to the vertical.

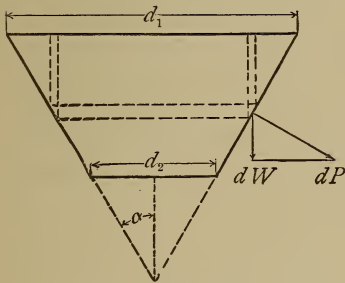

Fig. 47.

As in the case of a flat ring the intensity of the vertical pressure is

$$p = \frac{4W}{\pi(d_1^2 - d_2^2)}$$

and the vertical pressure on an elementary ring of the bearing surface is

$$dW = \frac{4W}{\pi(d_1^2 - d_2^2)} \times 2\pi r dr = \frac{8Wrdr}{d_1^2 - d_2^2}$$

As seen in Fig. 47 the normal pressure on the elementary ring is

$$dP = \frac{dW}{\sin \alpha} = \frac{8Wrdr}{(d_1^2 - d_2^2) \sin \alpha}$$

The friction on the ring is fdP and the moment of this friction is

$$dT = fr dP = \frac{8Wfr^2 dr}{(d_1^2 - d_2^2) \sin \alpha}$$

$$T = \frac{8Wf}{(d_1^2 - d_2^2) \sin \alpha} \int_{\frac{d_2}{2}}^{\frac{d_1}{2}} r^2 dr$$

$$= \frac{1}{3} \frac{Wf}{\sin \alpha} \frac{d_1^3 - d_2^3}{d_1^2 - d_2^2} \dots \dots \dots (70)$$

As α approaches $\frac{\pi}{2}$ the value of T approaches that of a flat ring, and as α approaches 0 the value of T approaches ∞ .

If $d_2 = 0$ we have

$$T = \frac{1}{3} \frac{Wfd}{\sin \alpha} \dots \dots \dots (71)$$

The conical pivot also wears unevenly, usually assuming a concave shape as seen in profile.

55. Schiele's Pivot. By experimenting with a pivot and bearing made of some friable material, it was shown that the outline tended to become curved as shown in Fig. 49. This led to a mathematical investigation which showed that the curve would be a tractrix under certain conditions.

This curve may be traced mechanically as shown in Fig. 48.

Let the weight W be free to move on a plane. Let the string SW be kept taut and the end S moved along the straight line SL . Then will a pencil attached to the center of W trace on the plane a tractrix whose axis is SL .

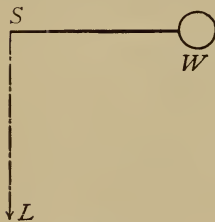

Fig. 48:

In Fig. 49 let $SW = \text{length of string} = r_1$, and let P be any point in the curve. Then it is evident that the tangent PQ to the curve is a constant and $= r_1$.

$$\text{Also } \frac{r}{\sin\theta} = r_1$$

Let a pivot be generated by revolving the curve around its axis SL . As in the case of the conical pivot it can be proved that the normal pressure on an element of convex surface is

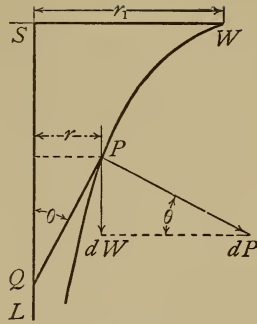

Fig. 49.

$$dP = \frac{8Wrdr}{(d_1^2 - d_2^2)\sin\theta} \dots \dots \dots (a)$$

Let the normal wear of the pivot be assumed to be proportional to this normal pressure and to the velocity of the rubbing surfaces, *i. e.* normal wear proportional to pr , then is the vertical wear proportional to $\frac{pr}{\sin\theta}$. But $\frac{r}{\sin\theta}$ is a constant, therefore the vertical wear will be the same at all points. This is the characteristic feature and advantage of this form of pivot.

As shown in equation (a)

$$dP = \frac{8Wr_1dr}{d_1^2 - d_2^2}$$

$$\therefore dT = \frac{8Wfr_1rdr}{d_1^2 - d_2^2}$$

and

$$T = \frac{8Wfr_1}{d_1^2 - d_2^2} \frac{r_1^2 - r_2^2}{2} = \frac{Wfd_1}{2} \dots \dots (72)$$

T is thus shown to be independent of d_2 , or of the length of pivot used.

This pivot is sometimes wrongly called antifriction. As will be seen by comparing equations (68) and (72) the moment of friction is fifty per cent. greater than that of the common flat pivot.

The distinct advantage of the Schiele pivot is in the fact that it maintains its shape as it wears and is self-adjusting. It is an expensive bearing to manufacture and is seldom used on that account.

It is not suitable for a bearing where most of the pressure is side ways.

56. Multiple Bearings. To guard against abrasion in flat pivots a series of rubbing surfaces which divide the wear is sometimes provided. Several flat discs placed beneath the pivot and turning indifferently, may be used. Sometimes the discs are made alternately of a hard and a soft material. Bronze, steel and raw hide are the more common materials.

Notice in this connection the button or washer at the outer end of the head spindle of an engine lathe and the loose collar on the main journal of a milling machine. See Figs. 41 and 42. Pivots are usually lubricated through a hole at the center of the bearing and it is desirable to have a pressure head on the oil to force it in.

The compound thrust bearing generally used for propeller shafts consists of a number of collars of the same size forged on the shafts at regular intervals and dividing the end thrust between them, thus reducing the intensity of pressure to a safe limit without making the collars unreasonably large.

A safe value for p the intensity of pressure is, according to Whitham, 60 lb. per sq. in. for high speed engines.

A table given by Prof. Jones in his book on Machine Design shows the practice at the Newport News ship-yards on marine engines of from 250 to 5000 H. P. The outer diameter of collars is about one and one-half times the diameter of the shafts in each case and the number of collars used varies from 6 in the smallest engine to 11 in the largest. The pressure per sq. in. of bearing surface varies from 18 to 46 lb. with an average value of about 32 lb.

The hydraulic foot step sometimes used for the vertical shafts of turbines is in effect a rotating plunger supported by water pressure underneath and so packed in its bearing as to allow a slight leakage of water for cooling and lubricating the bearing surfaces.

PROBLEMS.

1. Design and draw to full size a Schiele pivot for a water wheel shaft 4 inches in diameter, the total length of the bearing being 3 inches.

Calculate the horse-power expended in friction if the total vertical pressure on the pivot is two tons and the wheel makes 150 revs. per min. and assuming $f=.25$ for metal on wet wood.

2. Compare the friction of the pivot in Prob. 1, with that of a flat collar of the same projected area and also with that of a conical pivot having $\alpha=30$ deg.

3. Design a compound thrust bearing for a propeller shaft the diameters being 14 and 21 inches, the total thrust being 80,000 lbs. and the pressure 40 lb. per sq. in.

Calculate the horse-power consumed in friction and compare with that developed if a single collar of same area had been used. Assume $f=.05$ and rev. per min. =120.

CHAPTER VIII.

BALL AND ROLLER BEARINGS.

57. General Principles. The object of interposing a ball or roller between a journal and its bearing, is to substitute rolling for sliding friction and thus to reduce the resistance. This can be done only partially and by the observance of certain principles. In the first place it must be remembered that each ball can roll about but one axis at a time; that axis must be determined and the points of contact located accordingly.

Secondly, the pressure should be approximately normal to the surfaces at the points of contact

Finally it must be understood, that on account of the contact surfaces being so minute, a comparatively slight pressure will cause distortion of the balls and an entire change in the conditions.

58. Journal Bearings. These may be either two, three or four point, so named from the number of points of contact of each ball.

The axis of the ball may be assumed as parallel or inclined to the axis of the journal and the points of contact arranged accordingly. The simplest form consists of a plain cylindrical journal running in a bearing of the same shape and having rings of balls interposed. The successive rings of balls should be separated by thin loose collars to keep them in place. These collars are a source of rubbing friction, and to do away with them the balls are sometimes run in grooves either in journal, bearing or both.

Fig. 50 shows a bearing of this type, there being three points of contact and the axis of ball being parallel to that of journal.

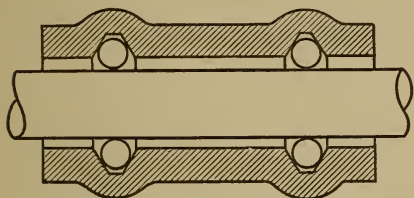

Fig. 50.

this deficiency. In designing this class of bearings, either for side or end thrust, the inclination of the axis is assumed according to the obliquity desired and the points of contact are then so located that there shall be no slipping.

Fig. 51 illustrates a common form of adjustable or cone bearing and shows the method of designing a three point contact.

AC is the axis of the cone, while the shaded area is a section of the cup, so called. Let a and b be two points of contact between ball and cup. Draw the line ab and produce to cut axis in A . Through the center of ball draw the line AB ; then will

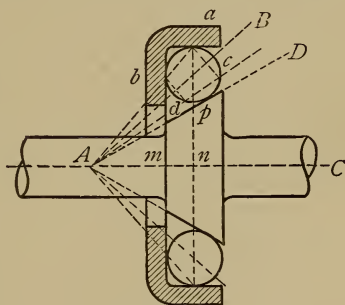

Fig. 51.

this be the axis of rotation of the ball and ac, bd will be the projections of two circles of rotation. As the radii of these circles have the same ratio as the radii of revolution an, bm , there will be no slipping and the ball will roll as a cone inside another cone. The

The bearings so far mentioned have no means of adjustment for wear. Conical bearings, or those in which the axes of the balls meet in a common point, supply

exact location of the third point of contact is not material. If it were at c , too much pressure would come on the cup at b ; if at d there would be an excess of pressure at a , but the rolling would be correct in either case. A convenient method is to locate p by drawing AD tangent to ball circle as shown. It is recommended however that the two opposing surfaces at p and b or a should make with each other an angle of not less than 25 deg. to avoid sticking of the ball.

To convert the bearing just shown to four point contact, it would only be necessary to change the one cone into two cones tangent to the ball at c and d .

To reduce it to two point contact the points a and b are brought together to a point opposite p . As in this last case the ball would not be confined to a definite path it is customary to make one or both surfaces concave conoids with a radius about three fourths the diameter of the ball. See Fig. 52.

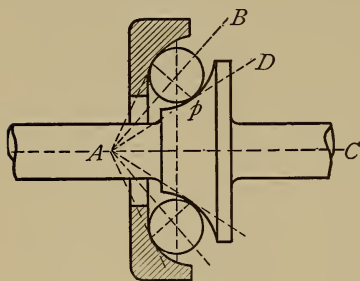

Fig. 52.

rings of balls. Each ring must be kept in place by one or more loose retaining collars, and these in turn are the cause of some sliding friction. This is a bearing with two point contact and the balls turning on horizontal axes. If the space between the plates is filled with loose balls, as is sometimes done, the rubbing

59. Step-Bearings. The same principles apply as in the preceding article and the axis and points of contact may be varied in the same way. The most common form of step-bearing consists of two flat circular plates separated by one or more

of the balls against each other will cause considerable friction.

To guide the balls without rubbing friction three point contact is generally used.

Fig. 53 illustrates a bearing of this character. The

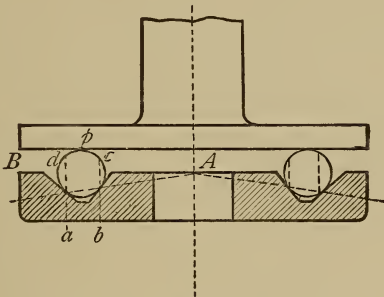

Fig. 53.

method of design is shown in the figure, the principle being the same as in Fig. 51. By comparing the lettering of the two figures the similarity will be readily seen.

This last bearing may be converted to four point contact by making the upper collar of the same shape as the lower. To guide the balls in two point contact use is sometimes made of a cage ring, a flat collar drilled with holes just a trifle larger than the balls and disposing them either in spirals or in irregular order. See Fig. 54.

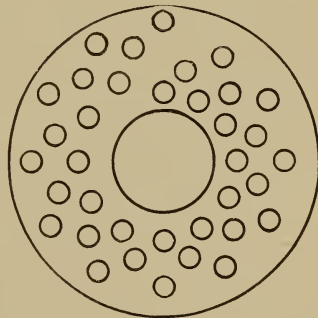

Fig. 54.

This method has the advantage of making each

ball move in a path of different radius thus securing more even wear for the plates.

60. Materials and Wear. The balls themselves are always made of steel, hardened in oil, tempered and ground. They are usually accurate to within one ten thousandth of an inch. The plates, rings and journals must be hardened and ground in the same way and perhaps are more likely to wear out or fail than the balls. A long series of experiments made at the Case School of Applied Science on the friction and endurance of ball step-bearings showed some interesting peculiarities.

Using flat plates with one circle of quarter inch balls it was found that the balls pressed outward on the retaining ring with such force as to cut and indent it seriously. This was probably due to the fact that the pressure slightly distorted the balls and changed each sphere into a partial cylinder at the touching points. While of this shape it would tend to roll in a straight line or a tangent to the circle. Grinding the plates slightly convex at an angle of one to one and-a-half degrees obviated the difficulty to a certain extent. Under even moderately heavy loads the continued rolling of the ring of balls in one path soon damaged the plates to such an extent as to ruin the bearing.

A flat bearing filled with loose balls developed three or four times the friction of the single ring and a three point bearing similar to that in Fig. 53 showed more than twice the friction of the two point.

A flat ring cage such as has already been described was the most satisfactory as regards friction and endurance.

The general conclusions derived from the experi-

ments were that under comparatively light pressures the balls are distorted sufficiently to seriously disturb the manner of rolling and that it is the elasticity and not the compressive strength of the balls which must be considered in designing bearings.

61. Design of Bearings. Figures on the direct crushing strength of steel balls have little value for the designer. For instance it has been proved by numerous tests that the average crushing strengths of $\frac{1}{4}$ inch and $\frac{3}{8}$ inch balls are about 7500 lb. and 15000 lb. respectively. Experiments made by the writer show that a $\frac{1}{4}$ inch ball loses all value as a transmission element on account of distortion, at any load of more than 100 lb.

Prof. Gray states, as a conclusion from some experiments made by him, that not more than 40 lb. per ball should be allowed for $\frac{3}{8}$ inch balls.

This distortion doubtless accounts for the failure of theoretically correct bearings to behave as was expected of them. Ball bearings should be designed as has been explained in the preceding articles and then only used for light loads.

62. Roller Bearings. The principal disadvantage of ball bearings lies in the fact that contact is only at a point and that even moderate pressure causes excessive distortion and wear. The substitution of cylinders or cones for the balls is intended to overcome this difficulty.

The simplest form of roller bearing consists of a plain cylindrical journal and bearing with small cylindrical rollers interposed instead of balls. There are two difficulties here to be overcome. The rollers tend

to work endways and rub or score whatever retains them. They also tend to twist around and become

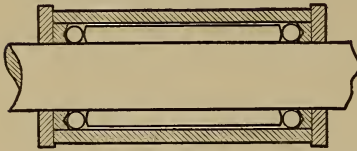

Fig. 55.

unevenly worn or even bent and broken, unless held in place by some sort of cage. In short they will not work properly unless guided and any form of guide entails

sliding friction. The cage generally used is a cylindrical sleeve having longitudinal slots which hold the rollers loosely and prevent their getting out of place either sideways or endways.

The use of balls or convex washers at the ends of the rollers has been tried with some degree of success. See Fig. 55. Large rollers have been turned smaller at the ends and the bearings then formed allowed to turn in holes bored in revolving collars. These collars must be so fastened or geared together as to turn in unison.

63. Grant Roller Bearing. The Grant roller is conical and forms an intermediate between the ball and the cylindrical roller having some of the advantages of each.

The principle is much the same as in the adjustable ball bearing, Fig. 52, rolling cones being substituted for balls, Fig. 56. The inner cone turns loose on the spindle. The conical rollers are held in position by rings at each end, while the outer or hollow cone ring is adjustable along the axis.

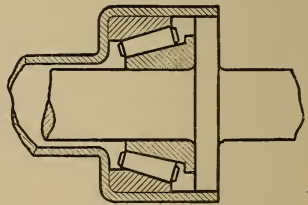

Fig. 56.

Two sets of cones are used on a bearing, one at each end to neutralize the end thrust, the same as with ball bearings.

64. Hyatt Rollers. The tendency of the rollers to get out of alignment has been already noticed. The Hyatt roller is intended by its flexibility to secure uniform pressure and wear under such conditions. It consists of a flat strip of steel wound spirally about a mandrel so as to form a continuous hollow cylinder. It is true in form and comparatively rigid against compression, but possesses sufficient flexibility to adapt itself to slight changes of bearing surface.

Experiments made by the Franklin Institute show that the Hyatt roller possesses a great advantage in efficiency over the solid roller.

Testing $\frac{3}{4}$ inch rollers between flat plates under loads increasing to 550 lb. per linear inch of roller developed co-efficients of friction for the Hyatt roller from 23 to 51 per cent. less than for the solid roller. Subsequent examination of the plates showed also a much more even distribution of pressure for the former.

A series of tests were conducted by the writer in 1904-05 to determine the relative efficiency of roller bearings, as compared with plain cast iron and bab-bitted bearings under similar conditions.¹ The bearings tested had diameters of $1\frac{1}{8}$, $2\frac{3}{8}$, $2\frac{7}{8}$, and $2\frac{1}{2}$ inches and lengths approximately four times the diameters. In the first set of experiments Hyatt roller bearings were compared with plain cast iron sleeves, at a uniform speed of 480 rev. per min. and under loads varying from 64 to 264 pounds. The cast iron bearings were copiously oiled.

¹ Machinery, N. Y., Oct. 1905.

As the load was gradually increased, the value of f the coefficient of friction remained nearly constant with the plain bearings, but gradually decreased in the case of the roller bearings. Table XXIII. gives a summary of this series of tests.

TABLE XXIII.

COEFFICIENTS OF FRICTION FOR ROLLER AND PLAIN BEARINGS.

Diameter of Journal.	Hyatt Bearing			Plain Bearing.		
	Max.	Min.	Ave.	Max.	Min.	Ave.
$1\frac{5}{16}$.036	.019	.026	.160	.099	.117
$2\frac{3}{16}$.052	.034	.040	.129	.071	.094
$2\frac{7}{16}$.041	.025	.030	.143	.076	.104
$2\frac{5}{16}$.053	.049	.051	.138	.091	.104

The relatively high value of f in the $2\frac{3}{16}$ and $2\frac{5}{16}$ roller bearings were due to the snugness of the fit between the journal and the bearing, and show the advisability of an easy fit as in ordinary bearings.

The same Hyatt bearings were used in the second set of experiments, but were compared with the McKeel solid roller bearings and with plain babbited bearings freely oiled. The McKeel bearings contained rolls turned from solid steel and guided by spherical ends fitting recesses in cage rings at each end. The cage rings were joined to each other by steel rods parallel to the rolls. The journals were run at a speed of 560 rev. per min. and under loads varying from 113 to 456 pounds. Table XXIV. gives a summary of the second series of tests.

TABLE XXIV.

COEFFICIENTS OF FRICTION FOR ROLLER AND PLAIN BEARINGS.

Diam. of Jo'rnal.	Hyatt Bearing.			McKeel Bearing.			Babbitt bearing.		
	Max.	Min.	Ave.	Max.	Min.	Ave.	Max.	Min.	Ave.
$1\frac{1}{8}$.032	.012	.018	.033	.017	.022	.074	.029	.043
$2\frac{3}{16}$.019	.011	.014088	.078	.082
$2\frac{7}{16}$.042	.025	.032	.028	.015	.021	.114	.083	.096
$2\frac{1}{2}$.029	.022	.025	.039	.019	.027	.125	.089	.107

The variation in the values for the babbited bearing is due to the changes in the quantity and temperature of the oil. For heavy pressures it is probable that the plain bearing might be more serviceable than the others. Notice the low values for f in Table XXII.

Under a load of 470 pounds the Hyatt bearing developed an end thrust of 13.5 pounds and the McKeel one of 11 pounds.

This is due to a slight skewing of the rolls and varies, sometimes reversing in direction.

If roller bearings are properly adjusted and not overloaded a saving of from two-thirds to three-fourths of the friction may be reasonably expected.

65. Roller Step-Bearings. In article 60 attention was called to the fact that the balls in a step-bearing under moderately heavy pressures tend to become cylinders or cones and to roll accordingly. This has suggested the use of small cones in place of the balls, rolling between plates one or both of which are also conical. A successful bearing of this kind with short

cylinders in place of cones is used by the Sprague-Pratt Elevator Co., and is described in the *American Machinist* for June 27, 1901. The rollers are arranged in two spiral rows so as to distribute the wear evenly over the plates and are held loosely in a flat ring cage. This bearing has run well in practice under loads double those allowable for ball bearings, or over 100 lb. per roll for rolls one-half inch in diameter and one-quarter inch long.

Fig. 57 illustrates a bearing of this character. Col-
lars similar to this have been used in thrust bearings

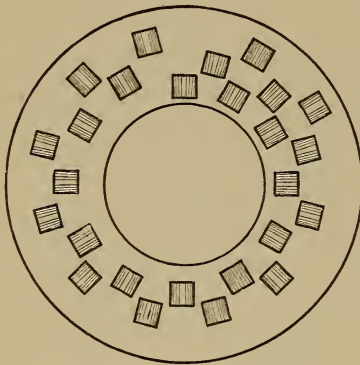

Fig. 57.

for propeller shafts. The discussion referred to in Art. 46 also included ball and roller bearings and should be read by the designer. Mr. Mossberg, designer of the roller bearings of that name, recommends rollers of spring tempered tool steel, cages of tough bronze and boxes of high carbon steel with a hard temper. Mr. Charles

R. Pratt reports the limit of work for $\frac{1}{2}$ inch balls in thrust bearings to be 100 pounds per ball at 700 revolutions per minute and 6 inches diameter circle of rotation.

Mr. W. S. Rogers gives the maximum load for a 1 inch ball as 1000 pounds and for a $\frac{1}{2}$ inch ball as 200 pounds. Mr. Henry Hess states that in a roller bearing one fifth of the number of rollers multiplied by the length and diameter of one roller may be considered as the projected area of the journal. For ball bearings one fifth the total number of balls multiplied by the

square of the ball diameter may be used in the same way.

Space forbids reference to all of the many varieties of ball and roller bearings shown in manufacturers' catalogues. These are all subject to the laws and limitations mentioned in this chapter,

While such bearings will be used more and more in the future, it must be understood that extremely high speeds or heavy pressures are unfavorable and in most cases prohibitive.

Furthermore, unless a bearing of this character is carefully designed and well constructed it will prove to be worse than useless.

CHAPTER IX.

SHAFTING, COUPLINGS AND HANGERS.

66. Strength of Shafting.

Let D = diameter of the driving pulley or gear.
 N = number rev. per minute.
 P = force applied at rim.
 T = twisting moment.

The distance through which P acts in one minute is πDN inches and work = $P\pi DN$ in. lb. per min.

But $\frac{PD}{2} = T$ the moment, and $2\pi N =$ the angular velocity.

\therefore work = moment \times angular velocity.

One horse power = 33000 ft. lb. per min.
 = 396000 in. lb. per min.

$$\therefore HP = \frac{P\pi DN}{396000} = \frac{2\pi TN}{396000}$$

or
$$HP = \frac{TN}{63025} \dots \dots \dots (73)$$

also
$$T = \frac{63025 HP}{N} \dots \dots \dots (74)$$

$$P = \frac{126050 HP}{DN} \dots \dots \dots (75)$$

The general formula for a circular shaft exposed to torsion alone is

$$d = \sqrt[3]{\frac{5.1 T}{S}}$$

But
$$T = \frac{63025 \text{ HP}}{N} \text{ by (74)}$$

where N = no. rev. per min.

Substituting in formula for d

$$d = \sqrt[3]{\frac{321000 \text{ HP}}{SN}} \text{ nearly . . . (76)}$$

S may be given the following values :

45000 for common turned shafting.

50000 for cold rolled iron or soft steel.

65000 for machinery steel.

It is customary to use factors of safety for shafting as follows :

Headshafts or prime movers	15
Line shafting	10
Short counters	6

The large factor of safety for head shafts is used not only on account of the severe service to which such shafts are exposed, but also on account of the inconvenience and expense attendant on failure of so important a part of the machinery. The factor of safety for line shafting is supposed to be large enough to allow for the transverse stresses produced by weight of pulleys, pull of belts, etc., since it is impracticable to calculate these accurately in most cases.

Substituting the values of S and introducing factors of safety, we have the following formulas for the safe diameters of the various kinds of shafts.

TABLE XXV.

DIAMETERS OF SHAFTING.

KIND OF SHAFT.	MATERIAL.		
	Com'n Iron	Soft Steel	Mach'y Steel
Head Shaft.	$4.75 \sqrt[3]{\frac{HP}{N}}$	$4.58 \sqrt[3]{\frac{HP}{N}}$	$4.20 \sqrt[3]{\frac{HP}{N}}$
Line Shaft.	$4.15 \sqrt[3]{\frac{HP}{N}}$	$4.00 \sqrt[3]{\frac{HP}{N}}$	$3.67 \sqrt[3]{\frac{HP}{N}}$
Counter Shaft.	$3.50 \sqrt[3]{\frac{HP}{N}}$	$3.38 \sqrt[3]{\frac{HP}{N}}$	$3.10 \sqrt[3]{\frac{HP}{N}}$

The Allis-Chalmers Co. base their tables for the horse power of wrought iron or mild steel shafting on the formula $HP = cd^3N$ where c has the following values:

	c
Heavy or main shafting	.008
Shaft carrying gears	.010
Light shafting with pulleys	.013

This is equivalent to using values of S as 2570 lb., 3200 lb. and 4170 lb. per sq. in. in the respective classes—and would give for co-efficients in Table XXV. the numbers 5, 4.64 and 4.25 which are somewhat larger than those given for similar cases in the table.

A table published by Wm. Sellers & Co. in their shafting catalogue—gives the horse powers of iron and steel shafts for given diameters and speeds. An investi-

gation of the table shows it to be based upon a value of about 4000 lb. for S or a co-efficient of 4.31 in Table XXV.

In case there is a known bending moment M , combined with a known twisting moment T , then a resultant twisting moment

$$T' = M + \sqrt{M^2 + T^2}$$

is to be substituted for T in the formulas (73) to (75).

Mr. J. B. Francis has published a table in the Journal of the Franklin Institute which gives the greatest admissible distance between bearings for line shafts of different diameters, when subject to no transverse forces except from their own weight. This distance varies from 16 feet for 2 inch shafts up to 26 feet for 9 inch shafts, the span being proportional to the cube root of the diameter. The distance should be much less when the shaft carries numerous pulleys with their belts.

67. Couplings. The flange or plate coupling is most commonly used for fastening together adjacent lengths of shafting.

Fig. 58 shows the proportions of such a coupling. The flanges are turned accurately on all sides, are keyed to the shafts and the two are centered by the projection of the shaft from one part into the other as shown at A . The bolts are turned to fit the holes loosely so as not to interfere with the alignment.

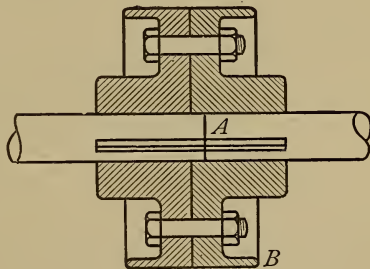

Fig. 58.

The projecting rim as at *B* prevents danger from belts catching on the heads and nuts of the bolts.

The faces of this coupling should be trued up in a lathe after being keyed to the shaft.

Jones and Laughlins in their shafting catalogue give the following proportions for flange couplings.

Diam. of Shaft.	Diam. of Hub.	Length of Hub.	Diam. of Coupling.
2	$4\frac{1}{2}$	$3\frac{1}{2}$	8
$2\frac{1}{2}$	$5\frac{5}{8}$	$4\frac{3}{8}$	10
3	$6\frac{3}{4}$	$5\frac{1}{4}$	12
$3\frac{1}{2}$	8	$6\frac{1}{8}$	14
4	9	7	16
5	$11\frac{1}{4}$	$8\frac{3}{4}$	20

There are five bolts in each coupling.

The sleeve coupling is neater in appearance than the flange coupling but is more complicated and expensive.

In Fig. 59 is illustrated a neat and effective coupling

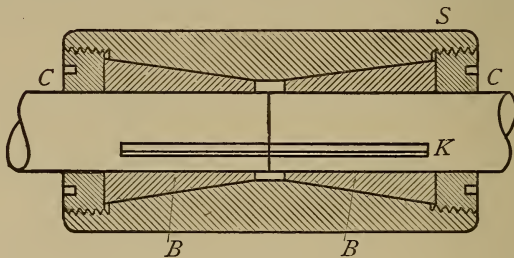

Fig. 59.

of this type. It consists of the sleeve *S* bored with two tapers and two threaded ends as shown. The two conical, split bushings *B B* are prevented from turning by the feather key *K* and are forced into the conical recesses by the two threaded collars *C C* and thereby

clamped firmly to the shaft. The key *K* also nicks slightly the center of the main sleeve *S*, thus locking the whole combination.

Couplings similar to this have been in use in the Union Steel Screw Works, Cleveland, Ohio, for many years and have given good satisfaction.

The Sellers coupling is of the type illustrated in Fig. 59, but is tightened by three bolts running parallel to the shaft and taking the place of the collars *C C*.

In another form of sleeve coupling the sleeve is split and clamped to the shaft by bolts passing through the two halves as illustrated in Fig. 60.

The "muff" coupling, as its name implies is a plain sleeve slipped over the shafts

at the point of junction, accurately fitted and held by a key running from end to end. It may be regarded as a permanent coupling since it is not readily removed.

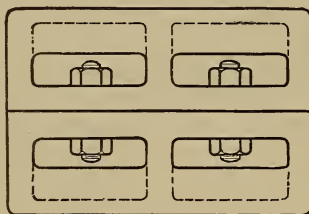

Fig. 60.

68. Clutches. By the term clutch, is meant a coupling which may be readily disengaged so as to stop the following shaft or pulley. Clutch couplings are of two kinds, positive or jaw clutches and friction clutches.

The jaw clutch consists of two hubs having sector shaped projections on the adjacent faces which may interlock. One of the couplings can be slid on its shaft to and from the other by means of a loose collar and yoke, so as to engage or disengage with its mate. This clutch has the serious disadvantage of not being readily engaged when either shaft is in motion.

driving by friction. Using the same notation as before, and letting $a =$ angle between element of cone and axis, the normal pressure between the two surfaces will be: $\frac{P}{\sin a}$ and the friction will be: $\frac{Pf}{\sin a}$.

Therefore: $T = \frac{Pfr}{\sin a}$ (78)

a should slightly exceed 5 deg. to prevent sticking and f will be at least 0.10 for dry iron on iron.

Substituting $f = 0.10$ and $\sin a = 0.125$ we have $T = 0.8Pr$ as a convenient rule in designing.

Fig. 62 illustrates the type of clutch more generally used on shafting for transmitting moderate quantities of power.

As shown in the figure one member is attached to a loose pulley on the shaft, but this same type can be used for connecting two independent shafts.

The ring or hoop H , finished inside and out, is gripped at intervals by pairs of jaws JJ having wooden faces.

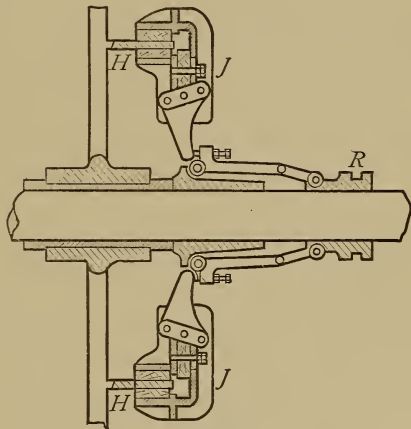

Fig. 62.

These jaws are actuated as shown by toggles and levers connected with the slip ring R . The toggles are so adjusted as to pass by the center and lock in the gripping position.

These clutches are convenient and durable but

occupy considerable room in proportion to their transmitting power. The Weston clutch is preferable for heavy loads.

The roller clutch is much used on automatic machinery as it combines the advantages of positive driving and friction engagement. A cylinder on the follower is embraced by a rotating ring carried by the driver.

The ring has a number of recesses on its inner surface which hold hardened steel rollers. These recesses being deeper at one end allow the rollers to turn freely as long as they remain in the deep portions.

The bottom of the recess is inclined to the tangent of the circle at an angle of from 9 to 14 deg.

When by suitable mechanism the rollers are shifted to the shallow portions of the recesses they are immediately gripped between the ring and the cylinder and set the latter in motion.

A clutch of this type is almost instantaneous in its action and is very powerful, being limited only by the strength of the materials of which it is composed.

Several small rolls of different materials and diameters were tested by the writer in 1905 with the following results :

Material.	Diameter.	Length.	Set load.	Ultimate load.
Cast Iron	0.375	1.5	5500	12400
“	0.75	1.5	6800	19500
“	1.125	1.5	7800	29700
“	0.4375	1.5	8800	20000
Soft Steel	0.4375	1.5	11100
Hard Steel	0.4375	1.5	35000

69. Coupling Bolts. The bolts used in the ordinary flange couplings are exposed to shearing, and their

combined shearing moment should equal the twisting moment on the shaft.

Let n = number of bolts.

d_1 = diameter of bolt.

D = diameter of bolt circle.

We will assume that the bolt has the same shearing strength as the shaft. The combined shearing strength of the bolts is $.7854d_1^2nS$ and their moment of resistance to shearing is

$$.7854d_1^2nS \times \frac{D}{2} = .3927Dd_1^2nS$$

This last should equal the torsion moment of the shaft or $.3927Dd_1^2nS = \frac{Sd^3}{5.1}$

Solving for d_1 and assuming $D=3d$ as an average value, we have $d_1 = \frac{d}{\sqrt{6n}}$ (79)

In practice rather larger values are used than would be given by the formula.

70. Shafting Keys. The moment of the shearing stress on a key must also equal the twisting moment of the shaft.

Let b = breadth of a key.

l = length of key.

h = total depth of key.

S' = shearing strength of key.

The moment of shearing stress on key is

$$blS' \times \frac{d}{2} = \frac{bdlS'}{2}$$

and this must equal $\frac{Sd^3}{5.1}$ Usually $b = \frac{d}{4}$

For shafts of machine steel $S=S'$, and for iron shafts $S = \frac{3}{4}S'$ nearly, as keys should always be of steel.

Substituting these values and reducing :

For iron shafting $l=1.2d$ nearly.

For steel shafting $l=1.6d$ nearly, as the least lengths of key to prevent its failing by shear.

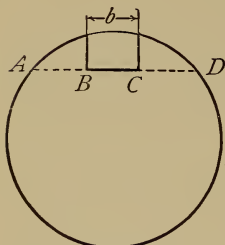

Fig. 63.

If the key way is to be designed for uniform strength, the shearing area of the shaft on the line AB , Fig. 63, should equal the shearing area of the key, if shaft and key are of the same material and $AB=CD=b$.

These proportions will make the depth of key way in shaft about $=\frac{5}{8}b$ and would be appropriate for a square key.

To avoid such a depth of key way which might weaken the shaft, it is better to use keys longer than required by preceding formulas. In American practice the total depth of key rarely exceeds $\frac{5}{8}b$ and one-half of this depth is in shaft.

To prevent crushing of the key the moment of the compressive strength of half the depth of key must equal T .

or
$$\frac{d}{2} \times \frac{lh}{2} \times S_c = \frac{Sd^3}{5.1} \dots \dots \dots (a)$$

where S_c is the compressive strength of the key.

For iron shafts $S_c = 2S$

and for steel shafts $S_c = \frac{3}{2}S$

Substituting values of S_c and assuming $h = \frac{5}{8}b = \frac{5}{32}d$ we have

Iron shafts $l = 2.5d$ nearly.

Steel shafts $l = 3\frac{1}{3}d$ nearly, as the least length for flat keys to prevent lateral crushing.

The above refers to parallel keys. Taper keys have parallel sides, but taper slightly between top and bottom. When driven home they have a tendency to tip the wheel or coupling on the shaft. This may be partially obviated by using two keys 90 deg. apart so as to give three points of contact between hub and shaft. The taper of the keys is usually about $\frac{1}{4}$ inch to one foot.

The Woodruff key is sometimes used on shafting. As may be seen in Fig. 64 this key is semi-circular in shape and fits a recess sunk in the shaft by a milling cutter.

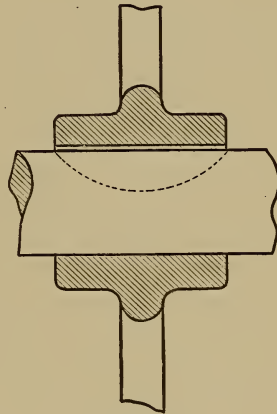

Fig. 64.

71. Hangers and Boxes. Since shafting is usually hung to the ceiling and walls of buildings it is necessary to provide means for adjusting and aligning the bearings as the movement of the building disturbs them. Furthermore as line shafting is continuous and is not perfectly true and straight, the bearings should be to a certain extent self-adjusting. Reliable experiments have shown that usually one-half of the power developed by an engine is lost in the friction of shafting and belts. It is important that this loss be prevented as far as possible.

The boxes are in two parts and may be of bored cast-iron or lined with Babbitt metal. They are usually about four diameters of the shaft in length and are oiled by means of a well and rings or wicks. (See Art.

44.) The best method of supporting the box in the hanger is by the ball and socket joint; all other contrivances such as set screws are but poor substitutes.

Fig. 65 shows the usual arrangement of the ball and socket.

A and *B* are the two parts of the box. The center is cast in the shape of a partial sphere with *C* as a center as shown by the dotted lines. The two sockets *S S* can be adjusted vertically in the hanger by means

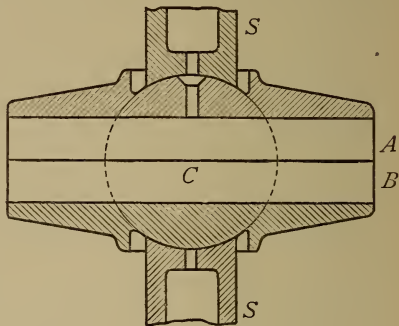

Fig. 65.

of screws and lock nuts. The horizontal adjustment of the hanger is usually effected by moving it bodily on the support, the bolt holes being slotted for this purpose.

Counter shafts are short and light and are not subject to much bending. Consequently there is not the same need of adjustment as in line shafting.

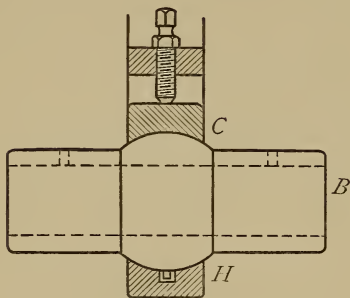

Fig. 66.

In Fig. 66 is illustrated a simple bearing for counters. The solid cast iron box *B* with a spherical center is fitted directly in a socket in the hanger *H* and held in position by the cap *C* and a set screw.

There is not space here to show all the various forms

of hangers and floor stands and reference is made to the catalogues of manufacturers. Hangers should be symmetrical, i. e., the center of the box should be in a vertical line with center of base. They should have relatively broad bases and should have the metal disposed to secure the greatest rigidity possible. Cored sections are to be preferred.

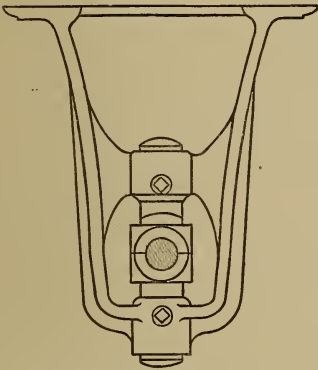

Fig. 67.

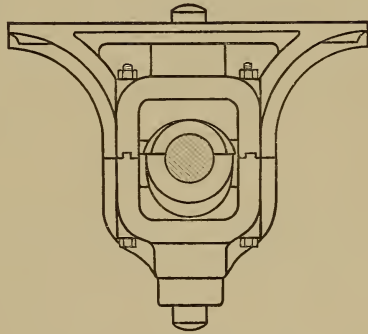

Fig. 68.

Fig. 67 illustrates the proportions of a Sellers line-shaft hanger. This type is also made with the lower half removable so as to facilitate taking down the shaft.

Fig. 68 shows the outlines of a hanger for heavy shafting as manufactured by the Jones & Laughlins Company while Fig. 69 illustrates the design of the box with oil wells and rings.

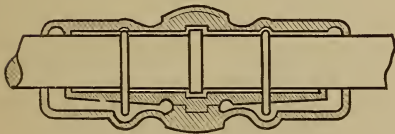

Fig. 69.

The open side hanger is sometimes adopted on ac-

count of the ease with which the shaft can be removed,

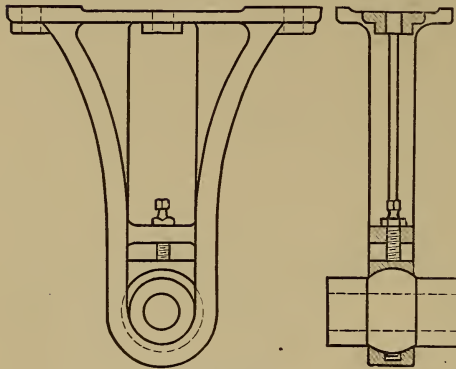

Fig. 70.

but it is much less rigid than the closed hanger and is suitable only for light shafting. The countershaft hanger shown in Fig. 70 is simple, strong and symmetrical and is a great improvement over those using pointed set screws for pivots.

Hangers similar to this are used by the Brown & Sharpe Mfg. Co. with some of their machines.

PROBLEMS.

1. Calculate the safe diameters of head shaft and three line shafts for a factory, the material to be rolled iron and the speeds and horse-powers as follows :

Head shaft	100 H P	200 rev. per min.
Machine shop	30 H P	120 rev. per min.
Pattern shop	50 H P	250 rev. per min.
Forge shop	20 H P	200 rev. per min.

2. Determine the horse-power of at least two lines of shafting whose speeds and diameters are known.

3. Design and sketch to scale a flange coupling for a three inch line shaft including bolts and keys.

4. Design a sleeve coupling for the foregoing, different in principle from the ones shown in the text.

5. A four-inch steel head shaft makes 100 rev. per min. Find the horse-power which it will safely transmit, and design a Weston ring clutch capable of carrying the load.

There are to be six wooden rings and five iron rings of 12 in. mean diameter. Find the moment carried by each pair of surfaces in contact and the end pressure required.

6. Find mean diameter of a single cone clutch for same shaft with same end pressure.

7. Find radial pressure required for a clutch like that shown in Fig. 62, the ring being 24 in. in mean diameter and there being four pairs of grips. Other conditions as in preceding problems.

8. Select the line shaft hanger which you prefer among those in the laboratories and make sketch and description of the same.

9. Do. for a countershaft hanger.

10. Explain in what way a floor-stand differs from a hanger.

CHAPTER X.

GEARS, PULLEYS AND CRANKS.

72. Gear Teeth. The teeth of gears may be either cast or cut, but the latter method prevails, since cut gears are more accurate and run more smoothly and quietly. The proportions of the teeth are essentially the same for the two classes, save that more back lash must be allowed for the cast teeth. The circular pitch is obtained by dividing the circumference of the pitch circle by the number of teeth. The diametral pitch is obtained by dividing the number of teeth by the diameter of the pitch circle and equals the number of teeth per inch of diameter. The reciprocal of the diametral pitch is sometimes called the module. The addendum is the radial projection of the tooth beyond the pitch circle, the dedendum the corresponding distance inside the pitch circle. The clearance is the difference between the dedendum and addendum; the back lash the difference between the widths of space and tooth on the pitch circle.

Let circular pitch = p .

 module = $\frac{p}{\pi} = m$.

 diametral pitch = $\frac{\pi}{p} = \frac{1}{m}$.

 addendum = a .

 dedendum or flank = f .

 clearance = $f - a = c$.

 height = $a + f = h$.

 width = w .

(See Fig. 72.)

The usual rule for standard cut teeth is to make $w = \frac{p}{2}$, allowing no calculable back-lash, to make $a = m$ and $f = \frac{9m}{8}$ or $h = 2\frac{1}{8}m$ and clearance $= \frac{m}{8}$.

There is however a marked tendency at the present time towards the use of shorter teeth. The reasons urged for their adoption are : first, greater strength and less obliquity of action ; second, less expense in cutting.* Several systems have been proposed in which the height of tooth h varies from $0.425p$ to $0.55p$.

According to the latter system $a = 0.25p$, $f = 0.3p$, and $c = .05p$.

In modern practice the diametral pitch is a whole number or a common fraction and is used in describing the gear. For instance a 3 pitch gear is one having 3 teeth per inch of diameter. The following table gives the pitches in common use and the proportions of long and short teeth.

If the gears are cut, $w = \frac{p}{2}$; if cast gears are used, $w = 0.46p$ to $0.48p$.

* See American Machinist, Jan. 7, 1897, p. 6.

TABLE XXVI.

PROPORTIONS OF GEAR TEETH.

PITCH.		STANDARD TEETH.			SHORT TEETH.		
Diamet- tral.	Circular.	Addend. <i>a</i>	Height. <i>h</i>	Clear- ance. <i>c</i>	Addend. <i>a</i>	Height. <i>h</i>	Clear- ance. <i>c</i>
$\frac{1}{2}$	6.283	2.	4.25	0.25	1.571	3.456	0.314
$\frac{3}{4}$	4.189	1.33	2.82	0.167	1.047	2.303	0.209
1	3.142	1.	2.125	0.125	0.785	1.728	0.157
$1\frac{1}{4}$	2.513	0.8	1.7	0.1	0.628	1.383	0.125
$1\frac{1}{2}$	2.094	0.667	1.415	0.083	0.524	1.152	0.105
$1\frac{3}{4}$	1.795	0.571	1.212	0.071	0.449	0.988	0.09
2	1.571	0.5	1.062	0.062	0.392	0.863	0.078
$2\frac{1}{4}$	1.396	0.445	0.945	0.056	0.349	0.768	0.070
$2\frac{1}{2}$	1.257	0.4	0.85	0.05	0.314	0.691	0.063
$2\frac{3}{4}$	1.142	0.364	0.775	0.045	0.286	0.629	0.057
3	1.047	0.333	0.708	0.042	0.262	0.576	0.052
$3\frac{1}{2}$	0.898	0.286	0.608	0.036	0.224	0.494	0.045
4	0.785	0.25	0.531	0.031	0.196	0.432	0.039
5	0.628	0.2	0.425	0.025	0.157	0.345	0.031
6	0.524	0.167	0.354	0.021	0.131	0.288	0.026
7	0.449	0.143	0.304	0.018	0.112	0.246	0.022
8	0.393	0.125	0.266	0.016	0.098	0.216	0.020
9	0.349	0.111	0.236	0.014	0.087	0.191	0.017
10	0.314	0.1	0.212	0.012	0.079	0.174	0.016
11	0.286	0.091	0.193	0.011	0.071	0.156	0.014
12	0.262	0.0834	0.177	0.010	0.065	0.143	0.013
13	0.242	0.077	0.164	0.010	0.060	0.132	0.012
14	0.224	0.0715	0.152	0.009	0.056	0.123	0.011
15	0.209	0.0667	0.142	0.008	0.052	0.114	0.010
16	0.196	0.0625	0.133	0.008	0.049	0.108	0.010

73. Strength of Teeth.

Let P = total driving pressure on wheel at pitch circle. This may be distributed over two or more teeth, but the chances are against an even distribution.

Again, in designing a set of gears the contact is likely to be confined to one pair of teeth in the smaller pinions.

Each tooth should therefore be made strong enough to sustain the whole pressure.

Rough Teeth. The teeth of pattern molded gears are apt to be more or less irregular in shape, and are especially liable to be thicker at one end on account of the draft of the pattern.

In this case the entire pressure may come on the outer corner of a tooth and tend to cause a diagonal fracture.

Let C in Fig. 71 be the point of application of the pressure P , and AB the line of probable fracture.

Drop the
 \perp CD on
 AB

Let $AB = x$
 and
 $CD = y$
 angle
 $CAD = \alpha$

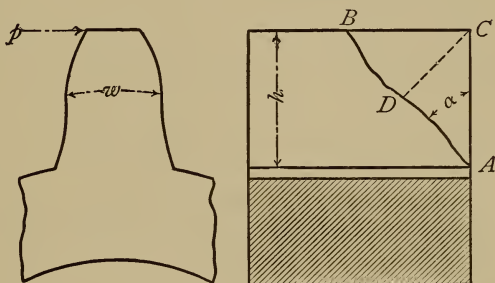

Fig. 71.

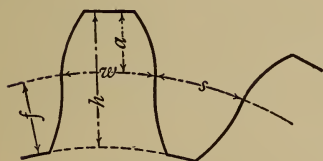

Fig. 72.

The bending moment at section AB is $M = Py$, and the moment of resistance is

$$M' = \frac{1}{6} Sxw^2$$

were $S =$ safe transverse

strength of material.

$$Py = \frac{1}{6} Sxw^2$$

and

$$S = \frac{6Py}{w^2x} \dots \dots \dots (a)$$

If P and w are constant, then S is a maximum when $\frac{y}{x}$ is a maximum.

But $y = h \sin a$ and $x = \frac{h}{\cos a}$

$$\frac{y}{x} = \sin a \cos a \text{ which is a}$$

maximum when $a = 45^\circ$ and $\frac{y}{x} =$

Substituting this value in (α) we have $S = \frac{3P}{w^2}$

But in this case $w = .47p$ and therefore $S = \frac{3 P}{.221p^2}$

and $p = 3.684 \sqrt{S} \dots \dots \dots (80)$

diametral pitch, $\frac{1}{m} = .853 \sqrt{\frac{S}{P}} \dots \dots \dots (81)$

Unless machine molded teeth are very carefully made, it may be necessary to apply this rule to them as well.

Cut Gears. With careful workmanship machine molded and machine cut teeth should touch along the whole breadth. In such cases we may assume a line of contact at crest of tooth and a maximum bending moment.

$$M = Ph$$

The moment of resistance at base of tooth is

$$M^1 = \frac{1}{6} S b w^2$$

when b is the breadth of tooth.

In most teeth the thickness at base is greater than w , but in radial teeth it is less. Assuming standard proportions for cut gears :

$$h = 2\frac{1}{8}m = .6765p$$

$$w = .5p$$

and substituting above :

$$.6765 Pp = \frac{Sbp^2}{24}$$

$$P = .0616bSp \quad (82)$$

For short teeth having $h = .55p$ formula (82) reduces to :

$$P = .0758bSp \quad (83)$$

The above formulas are general whatever the ratio of breadth to pitch. The general practice in this country is to make

$$b = 3p$$

Substituting this value of b in (82) and (83) and reducing :

$$\text{Long teeth : } p = 2.326 \sqrt{\frac{P}{S}} \quad (84)$$

$$\text{Short teeth : } p = 2.098 \sqrt{\frac{P}{S}} \quad (85)$$

The corresponding formulas for the diametral pitch are :

$$\text{Long teeth : } \frac{1}{m} = 1.35 \sqrt{\frac{S}{P}} \quad (86)$$

$$\text{Short teeth : } \frac{1}{m} = 1.49 \sqrt{\frac{S}{P}} \quad (87)$$

74. Lewis' Formulas. The foregoing formulas can only be regarded as approximate, since the strength of gear teeth depends upon the number of teeth in the wheel ; the teeth of a rack are broader at the base and consequently stronger than those of a pinion. This is more particularly true of epicycloidal teeth. Mr. Wilfred Lewis has deduced formulas which take into

account this variation. For cut spur gears of standard dimensions the Lewis formula is as follows :

$$P = bSp \left(.124 - \frac{.888}{n} \right). \quad \dots \dots \dots (88)$$

where n = number of teeth.

This formula reduces to the same as (82), for $n=14$ nearly.

Formula (82) would then properly apply only to small pinions, but as it would err on the safe side for larger wheels, it can be used where great accuracy is not needed. The same criticism applies to the other formulas in Art. 73.

The value of S used should depend on the material and on the speed.

The following safe values are recommended for cast iron and cast steel.

Linear velocity ft. per min.	100	200	300	600	900	1200	1800	2400
Cast Iron.....	8000	6000	4800	4000	3000	2400	2000	1700
Cast Steel....	24000	15000	12000	10000	7500	6000	5000	4250

For gears used in hoisting machinery where there is slow speed and liability of shocks a writer in the American Machinist recommends smaller values of S than those given above* and proposes the following for four different metals :

* American Machinist, Feb. 16, 1905.

Linear velocity ft. per min.	100	200	300	600	900	1200	1800	2400
Gray Iron.....	4800	4200	3840	3200	2400	1920	1600	1360
Gun Metal.....	7200	6300	5760	4800	3600	2880	2400	2040
Cast Steel.....	9600	8400	7680	6400	4800	3840	3200	2720
Mild Steel.....	12000	10500	9600	8000	6000	4800	4000	3400

The experiments described in the next article show that the ultimate values of S are much less than the transverse strength of the material and point to the need of large factors of safety.

75. Experimental Data. In the American Machinist for Jan. 14, 1897, are given the actual breaking loads of gear teeth which failed in service. The teeth had an average pitch of about 5 inches, a breadth of about 18 inches and the rather unusual velocity of over 2000 ft. per minute. The average breaking load was about 15000 lb. there being an average of about 50 teeth on the pinions. Substituting these values in (88) and solving we get

$$S=1575 \text{ lb.}$$

This very low value is to be attributed to the condition of pressure on one corner noted in Art. 73. Substituting in formula for such a case.

$$S = \frac{3P}{.221p^2} = 8150$$

This all goes to show that it is well to allow large factors of safety for rough gears, especially when the speed is high.

Experiments have been made on the static strength

of rough cast iron gear teeth at the Case School of Applied Science by breaking them in a testing machine. The teeth were cast singly from patterns, were two pitch and about 6 inches broad. The patterns were constructed accurately from templates representing 15 deg. involute teeth and cycloidal teeth drawn with a describing circle one-half the pitch circle of 15 teeth ; the proportions used were those given for standard cut gears.

There were in all 41 cycloidal teeth of shapes corresponding to wheels of 15-24-36-48-72-120 teeth and a rack. There were 28 involute teeth corresponding to numbers above given omitting the pinion of 15 teeth.

The pressure was applied by a steel plunger tangent to the surface of tooth and so pivoted as to bear evenly across the whole breadth. The teeth were inclined at various angles so as to vary the obliquity from 0 to 25 deg. for the cycloidal and from 15 deg. to 25 deg. for the involute. The point of application changed accordingly from the pitch line to the crest of the tooth. From these experiments the following conclusions are drawn :

1. The plane of fracture is approximately parallel to line of pressure and not necessarily at right angles to radial line through center of tooth.

2. Corner breaks are likely to occur even when the pressure is apparently uniform along the tooth. There were fourteen such breaks in all.

3. With teeth of dimensions given, the breaking pressure per tooth varies from 25000 lb. to 50000 lb. for cycloids as the number of teeth increases from 15 to infinity ; the breaking pressure for involutes of the same pitch varies from 34000 lb. to 80000 lb. as the number increases from 24 to infinity.

4. With teeth as above the average breaking pressure varies from 50000 lb. to 26000 lb. in the cycloids as the angle changes from 0 deg. to 25 deg. and the tangent point moves from pitch line to crest; with involute teeth the range is between 64000 and 39000 lb.

5. Reasoning from the figures just given, rack teeth are about twice as strong as pinion teeth and involute teeth have an advantage in strength over cycloidal of from forty to fifty per cent. The advantage of short teeth in point of strength can also be seen. The modulus of rupture of the material used was about 36000 lb. Values of S calculated from Lewis' formula for the various tooth numbers are quite uniform and average about 40000 lb. for cycloidal teeth. Involute teeth are to-day generally preferred by manufacturers. William Sellers & Co. use an obliquity of 20 deg. instead of $14\frac{1}{2}$ or 15 deg. the usual angle.

76. Teeth of Bevel Gears. There have been many formulas and diagrams proposed for determining the strength of bevel gear teeth, some of them being very complicated and inconvenient. It will usually answer every purpose from a practical standpoint, if we treat the section at the middle of the breadth of such a tooth as a spur wheel tooth and design it by the foregoing formulas. The breadth of the teeth of a bevel gear should be about one-third of the distance from the base of the cone to the apex.

One point needs to be noted; the teeth of bevel gears are stronger than those of spur gears of the same pitch and number of teeth since they are developed from a pitch circle having an element of the normal cone as a radius. To illustrate, we will suppose that we are designing the teeth of a miter gear and that

the number of teeth is 32. In such a gear the element of normal cone is $\sqrt{2}$ times the radius. The actual shape of the teeth will then correspond to those of a spur gear having $32\sqrt{2}=45$ teeth nearly.

NOTE.—In designing the teeth of gears where the number is unknown, the approximate dimensions may first be obtained by formula (84) or (85) and then these values corrected by using Lewis' formula.

PROBLEMS.

1. The drum of a hoist is 8 in. in diameter and makes 5 rev. per minute. The diameter of gear on the drum is 36 inches and of its pinion 6 in. The gear on the counter shaft is 24 in. in diameter and its pinion is 6 in. in diameter. The gears are all cut.

Calculate the pitch and number of teeth of each gear, assuming a load of one ton on drum chain and $S=6000$. Also determine the horse-power of the machine.

2. Calculate the pitch and number of teeth of a cut cast steel gear 10 in. in diameter, running at 250 rev. per min. and transmitting 20 HP.

3. A cast-iron gear wheel is 30 ft. $6\frac{3}{4}$ in. in pitch diameter and has 192 teeth, which are machine-cut and 30 in. broad.

Determine the circular and diameter pitches of the teeth and the horse-power which the gear will transmit safely when making 12 rev. per min.

4. A two pitch cycloidal tooth, 6 in. broad, 72 teeth to the wheel, failed under a load of 38000 lb. Find value of S by Lewis' formula.

5. A vertical water-wheel shaft is connected to horizontal head shaft by cast iron gears and transmits 150 HP. The water-wheel makes 200 rev. per min. and the head shaft 100.

Determine the dimensions of the gears and teeth if the latter are approximately two pitch.

6. Work Problem 1, using short teeth instead of standard.

77. **Rim and Arms.** The rim of a gear, especially if the teeth are cast, should have nearly the same thickness as the base of tooth, to avoid cooling strains.

It is difficult to calculate exactly the stresses on the arms of the gear, since we know so little of the initial stress present, due to cooling and contraction. A hub of unusual weight is liable to contract in cooling after the arms have become rigid and cause severe tension or even fracture at the junction of arm and hub.

A heavy rim on the contrary may compress the arms so as actually to spring them out of shape. Of course both of these errors should be avoided, and the pattern be so designed that cooling shall be simultaneous in all parts of the casting.

The arms of spur gears are usually made straight without curves or taper, and of a flat, elliptical cross-section, which offers little resistance to the air. To support the wide rims of bevel gears and to facilitate drawing the pattern from the sand, the arms are sometimes of a rectangular or *T* section, having the greatest depth in the direction of the axis of the gear. For pulleys which are to run at a high speed it is important that there should be no ribs or projections on arms or rim which will offer resistance to the air. Experiments by the writer have shown this resistance to be serious at speeds frequently used in practice.

A series of experiments conducted by the author are reported in the *American Machinist* for Sept. 22, 1898, to which paper reference is here made.

Twenty-four pulleys having $3\frac{1}{2}$ inches face and diameters of 16, 20 and 24 inches were broken in a testing machine by the pull of a steel belt, the ratio of the belt tensions being adjusted by levers so as to be

two to one. Twelve of the pulleys were of the ordinary cast-iron type having each six arms tapering and of an elliptic section. The other twelve were Medart pulleys with steel rims riveted to arms and having some six and some eight arms. Test pieces cast from the same iron as the pulleys showed an average modulus of rupture of 35800 for the cast-iron and 50800 for the Medart.

In every case the arm or the two arms nearest the side of the belt having the greatest tension, broke first, showing that the torque was not evenly distributed by the rim. Measurements of the deflection of the arms showed it to be from two to six times as great on this side as on the other. The buckling and springing of the rim was very noticeable especially in the Medart pulleys.

The arms of all the pulleys broke at the hub showing the greatest bending moment there, as the strength of the arms at the hub was about double that at the rim. On the other hand some of the cast iron arms broke simultaneously at hub and rim, showing a negative bending moment at the rim about one-half that at the hub.

The following general conclusions are justified by these experiments :

(a) The bending moments on pulley arms are not evenly distributed by the rim, but are greatest next the tight side of belt.

(b) There are bending moments at both ends of arm, that at the hub being much the greater, the ratio depending on the relative stiffness of rim and arms.

The following rules may be adopted for designing the arms of cast iron pulleys and gears :

1. Multiply the net turning pressure, whether caused

by belt or tooth, by a suitable factor of safety and by the length of the arm in inches. Divide this product by *one-half the number of arms* and use the quotient for a bending moment. Design the hub end of arm to resist this moment.

2. Make the rim ends of arms one-half as strong as the hub ends.

78. Sprocket Wheels and Chains. Steel chains connecting toothed wheels afford a convenient means of getting a positive speed ratio when the axes are some distance apart. There are three classes in common use, the block chain, the roller chain and the so-called "silent" chain.

Mr. A. Eugène Michel publishes quite a complete discussion of the design of the first two classes in *Machinery* for February, 1905, and reference is here made to that journal.

Block chain is that commonly used on bicycles and small motor cars, so named from the blocks with round ends which are used to fill in between the links. The sprocket teeth are spaced to a pitch greater than that of the chain links and the blocks rest on flat beds between the teeth, Fig. 73.

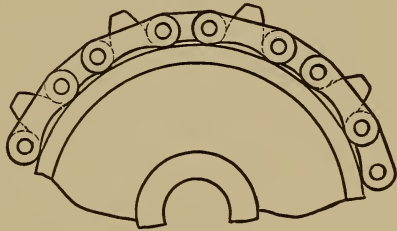

Fig. 73.

Roller chains have rollers on every pin and have inside and outside links. The sprocket teeth have the same pitch as the chain links, the rollers fitting circular recesses between the sprockets, Fig. 74.

The most serious failing of the chain is its tendency to stretch with use so that the pitch becomes greater than that of the sprocket teeth.

To obviate this difficulty in a measure considerable clearance should be given to the sprocket teeth as indicated in Fig. 74. As the pitch of the chain increases it will then ride higher upon the sprockets until the end of the tooth is reached. The teeth are rounded on

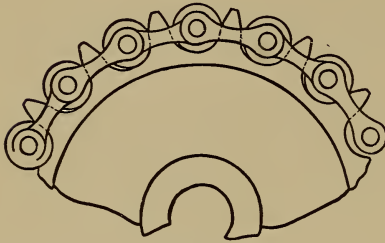

Fig. 74.

their side faces, that they may easily enter the gaps in the chain and have side clearance.

Mr. Michel gives the following values for the tensile strength of chains as determined by actual tests.

ROLLER CHAIN.

Pitch inches	$\frac{1}{2}$	$\frac{5}{8}$	$\frac{3}{4}$	1	$1\frac{1}{4}$	$1\frac{1}{2}$	$1\frac{3}{4}$	2
Tensile Strength lb.	1200	1200	4000	6000	9000	12000	19000	25000

BLOCK CHAIN.

1 inch pitch 1200 to 2500 lb.

$1\frac{1}{2}$ " " 5000 "

Mr. Michel further recommends a factor of safety of from 5 to 40 according to the severity of the conditions as to speed and shocks.

The tendency is to use short links and double or triple width chains to increase the rivet bearing sur-

face, as it is this latter factor which really determines the life of a chain.

Roller chains may be used up to speeds of 1000 to 1200 feet per minute.

The sprocket should be so designed that one tooth will carry the load safely with the pressure near the crest since these conditions obtain as the chain stretches. Use values of S as in Art. 74.

79. Silent Chains. The weak points in the ordinary chain, whether it be made with blocks or rollers, are the rivet bearings. It is the continual wear of these, due to insufficient area and lack of proper lubrication, that shortens the life of a chain.

The so-called "silent-chain" with rocker bearings, is comparatively free from this defect. Fig. 75 illustrates the shapes of links, rivets and sprockets for this kind of chain as manufactured by the Morse Chain Company.

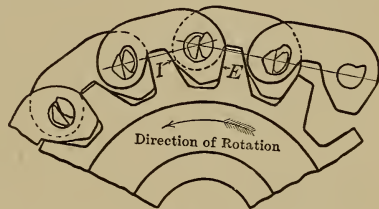

Fig. 75.

The chain proper is entirely outside of the sprocket teeth so that the latter may be continuous across the face of the wheel, save for a single guiding groove in the center.

Projections on the under side of the links engage with the teeth of the sprocket, E being the point of contact for the driver and I a similar point for the follower when the rotation is as indicated.

Each rivet consists practically of two pins called by the makers the rocker pin and the seat pin. Each pin is fastened in its particular gang of links and the

relative motion is merely a rocking of one pin on the other without appreciable friction.

The pins are of hardened tool steel with softened ends. The combination of this freedom from rubbing contact with the adaptation of the engaging tooth profiles, gives a chain which can be safely run at high speeds without objectionable vibration or appreciable wear.

The chains can be made of almost any width from one-half inch up to eighteen inches, the width depending upon the pitch of the chain and the power to be transmitted.

The following are the working loads (and limiting speeds) of chains two inches in width and of different pitches, taken from a table published by the makers :

Pitch in inches	$\frac{1}{2}$	$\frac{5}{8}$	$\frac{3}{4}$.9	1.2	1.5
Working load in pounds	130	190	236	380	520	760
Limiting Speed Rev. per min.	2000	1600	1200	1100	800	600

The number of teeth in the small sprocket may vary from 15 to 30 according to the conditions.

Assuming 17 teeth and the number of revolutions given in the above table the speed of chain would be 1420 feet per minute for the $\frac{1}{2}$ inch pitch and 1275 feet per minute for the 1.5 inch.

Chains of this character have been run successfully at 2000 feet per minute.

PROBLEMS.

1. Design eight arms of elliptic section for a gear 48 inches pitch diameter, to transmit a pressure on tooth of 800 pounds. Material, cast iron having a working transverse strength of 6000 pounds per square inch.

2. Two sprocket wheels of 75 and 17 teeth respectively are to transmit twenty horse-power at a chain speed of about 800 feet per minute, with a factor of safety of 12—

Determine the proper pitch of roller chain, the pitch diameters of the sprockets, and the numbers of revolutions.

3. Suppose that in Problem 2, a "silent" chain is to be used and the chain speed increased to 1200 feet per minute. Determine the proper pitch of chain to be used if the width of chain is 3 inches. Determine diameters and revolutions of sprockets as before.

Cranks and Levers. A crank or rocker arm which is used to transmit a continuous or reciprocating rotary motion is in the condition of a cantilever or bracket with a load at the outer end.

If the web of the crank is of uniform thickness theory requires that its profile should be parabolic for uniform strength, the vertex of the parabola being at the load point.

A convenient approximation to this shape can be attained by using the tangents to the parabola at

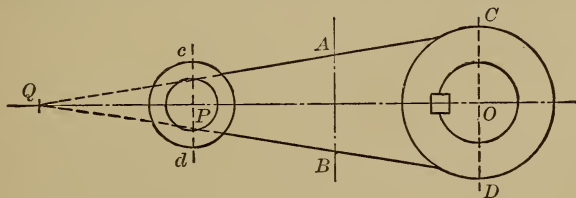

Fig. 76.

points midway between the hub and the load point. See Fig. 76. The crank web is designed of the right

thickness and breadth to resist the moment at AB , and the center line is produced to Q , making $PQ = \frac{1}{2} PO$.

Straight lines drawn from Q to A and B will be tangent to the parabola at the latter points and will serve as contour lines for the web.

Assume the following dimensions in inches :

l = length of crank = OP .

t = thickness of web.

h = breadth " " = AB .

d = diameter of eye = cd .

d_1 = " " pin.

b = breadth of eye.

D = diameter of hub = CD .

D_1 = " " shaft.

B = breadth of hub.

If the pressure on the crank pin is denoted by P then will the moment at AB be $\frac{Pl}{2}$ and the equations of moments for the cross-section will be :

$$\frac{Pl}{2} = \frac{St h^2}{6} \quad [\text{See Formula (3)}]$$

and from this the dimensions at AB may be calculated.

The moment at the hub will be Pl and will tend to break the iron on the dotted lines CD . The equation of moments for the hub is therefore :

$$Pl = \frac{SB}{6} (D^2 - D_1^2)$$

From this equation the dimensions of the hub may be calculated when D_1 is known. The eye of a crank is most likely to break when the pressure on the pin is along the line OP , and the fracture will be along the dotted lines cd . The bending moment will be P mul-

tiplied by the distance from center of pin to center of eye measured along axis of pin. If we call this distance x , then will the equation of moments be:

$$Px = \frac{Sb^2}{6}(d-d_1)$$

It is considered good practice among engine builders to make the values of x , b and B as small as practicable, in order to reduce the twisting moment on the web of the crank and the bending moment on the shaft. In designing the hub, allowance must be made for the metal removed at the key-way.

PROBLEM.

Design a cast steel crank for a steam engine having a cylinder 12 by 30 inches and an initial steam pressure of 120 lb. per sq. in. of piston. The shaft is 6 inches and the crank pin 3 inches in diameter. The distance x may be assumed as 4 inches. Calculate,

1. Dimensions of web at AB .
2. Dimensions of hub allowing for a key $1 \times \frac{3}{4}$ inches.
3. Dimensions of eye for pin, make a scale drawing in ink showing profile of crank complete, S may be assumed as 6,000 lb. per sq. in.

CHAPTER XI.

FLY-WHEELS.

81. In General. The hub and arms of a fly-wheel are designed in much the same way as those of pulleys and gears, the straight arm with elliptic section being the favorite. The rims of such wheels are of two classes, the wide, thin rim used for belt transmission and the narrow solid rim of the generator or blowing engine wheel. Fly-wheels up to eight or ten feet in diameter are usually cast in one piece; those from ten to sixteen feet in diameter may be cast in halves, while wheels larger than the last mentioned should be cast in sections, one arm to each section.

This is a matter, not of use, but of convenience in transportation.

The joints between hub and arms and between arms and rim need not be specially considered here, since wheels rarely fail at these points.

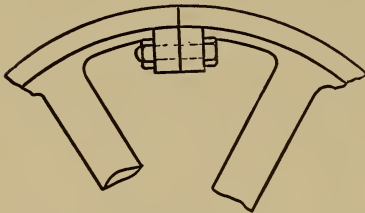

Fig. 77.

The rim and the joints in the rim cannot be too carefully designed. The smaller wheel cast in one piece is more or less subject to stresses caused by shrinkage. The sectional wheel is generally free from such stresses but is

weakened by the numerous joints.

Rim joints are of two general classes according as bolts or links are used for fastenings.

Wide, thin rims are usually fastened together by internal flanges and bolts as shown in Fig. 77, while the stocky rims of the fly-wheels proper are joined directly by links or *T*-head "prisoners" as in Fig. 78.

As will be shown later, the former is a weak and unreliable joint, especially when located midway between the arms.

The principal stresses in fly-wheel rims are caused by centrifugal force.

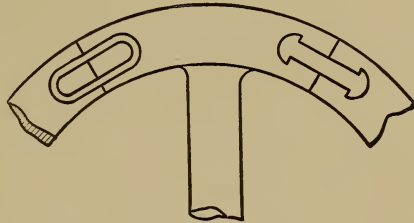

Fig. 78.

82. Safe Speed for Wheels. The centrifugal force developed in a rapidly revolving pulley or gear produces a certain tension on the rim, and also a bending of the rim between the arms. We will first investigate the case of a pulley having a rim of uniform cross section.

It is safe to assume that the rim should be capable of bearing its own centrifugal tension without assistance from the arms.

- Let D = mean diameter of pulley rim.
 t = thickness of rim.
 b = breadth of rim.
 w = weight of material per cu. in.
 = .26 lb. for cast-iron.
 = .28 lb. for wrought iron or steel.
 n = number of arms.
 N = number rev. per min.
 v = velocity of rim in ft. per sec.

It has been shown by Mr. James B. Stanwood, in a paper read before the American Society of Mechanical Engineers,* that each section of the rim between the arms is moreover in the condition of a beam fixed at the ends and uniformly loaded.

This condition will produce an additional tension on the outside of rim. The formula for such a beam when of rectangular cross-section is

$$\frac{Wl}{12} = \frac{Sbd^2}{6} \quad \dots \quad (b)$$

W in this case is the centrifugal force of the fraction of rim included between two arms.

The weight of this fraction is $\frac{\pi D b t w}{n}$ and its centrifugal force $W = \frac{\pi D b t w}{n} \times \frac{24v^2}{gD}$ or $W = \frac{24\pi b t w v^2}{gn}$

Also $l = \frac{\pi D}{n}$ and $d = t$

Substituting these values in (b) and solving for S :

$$S = 3.678 \frac{D w v^2}{t n^2} \quad \dots \quad (c)$$

If w is given an average value of .27 then

$$S = \frac{D v^2}{t n^2} \text{ nearly.} \quad \dots \quad (d)$$

and the total value of the tensile stress on outer surface of rim is

$$S' = \frac{D v^2}{t n^2} + \frac{v^2}{10} \text{ nearly.} \quad \dots \quad (93)$$

Solving for v :

$$v = \sqrt{\frac{S' t n^2}{D + \frac{1}{10}}} \quad \dots \quad (94)$$

In a pulley with a thin rim and small number of

* See Trans. A. S. M. E. Vol. XIV.

arms, the stress due to this bending is seen to be considerable.

It must, however, be remembered that the stretching of the arms due to their own centrifugal force and that of the rim will diminish this bending. Mr. Stanwood recommends a deduction of one-half from the value of S in (d) on this account.

Prof. Gaetano Lanza has published quite an elaborate mathematical discussion of this subject. (See Vol. XVI. Trans. Am. Soc. Mech. Engineers.) He shows that in ordinary cases the stretch of the arms will relieve more than one-half of the stress due to bending, perhaps three-quarters.

83. Experiments on Fly-Wheels. In order to determine experimentally the centrifugal tension and bending in rapidly revolving rims, a large number of small fly-wheels have been tested to destruction at the Case School laboratories. In all ten wheels, fifteen inches in diameter and twenty-three wheels two feet in diameter have been so tested. An account of some of these experiments may be found in Trans. Am. Soc. Mech. Eng. Vol. XX. The wheels were all of cast-iron and modeled after actual fly-wheels. Some had solid rims, some jointed rims and some steel spokes.

To give to the wheels the speed necessary for destruction, use was made of a Dow steam turbine capable of being run at any speed up to 10000 revolutions per minute. The turbine shaft was connected to the shaft carrying the fly-wheels by a brass sleeve coupling loosely pinned to the shafts at each end in such a way as to form a universal joint, and so proportioned as to break or slip without injuring the turbine in case of sudden stoppage of the fly-wheel shaft.

One experiment with a shield made of two-inch plank proved that safety did not lie in that direction, and in succeeding experiments with the fifteen inch wheels a bomb-proof constructed of 6×12 inch white oak was used. The first experiment with a twenty-four inch wheel showed even this to be a flimsy contrivance. In subsequent experiments a shield made of 12×12 inch oak was used. This shield was split repeatedly and had to be re-enforced by bolts.

A cast steel ring about four inches thick lined, with wooden blocks and covered with three inch oak planking, was finally adopted.

The wheels were usually demolished by the explosion. No crashing or rending noise was heard, only one quick, sharp report, like a musket shot.

The following tables give a summary of a number of the experiments.

TABLE XXVI.

FIFTEEN INCH WHEELS.

No.	Bursting Speed.		Centrifugal Tension $=\frac{v^2}{10}$	Remarks.
	Rev. per Minute.	Feet per Second = v .		
1	6,525	430	18,500	Six arms.
2	6,525	430	18,500	Six arms.
3	6,035	395	15,600	Thin rim.
4	5,872	380	14,400	Thin rim.
5	2,925	192	3,700	Joint in rim.
6	5,600*	368	13,600	Three arms.
7	6,198	406	16,500	Three arms.
8	5,709	368	13,600	Three arms.
9	5,709	365	13,300	Thin rim.
10	5,709	361	13,000	Thin rim.

* Doubtful.

TABLE XXVII.

TWENTY-FOUR INCH WHEELS.

No.	Shape and Size of Rim.					Weight of Wheel, Pounds
	Diameter Inches.	Breadth Inches.	Depth Inches.	Area Sq. Inches.	Style of Joint.	
11	24	2 $\frac{1}{8}$	1.5	3.18	Solid rim.	75.25
12	24	4 $\frac{1}{16}$.75	3.85	Internal flanges, bolted	93.
13	24	4	.75	3.85	" " "	91.75
14	24	4	.75	3.85	" " "	95.
15	24	4 $\frac{1}{16}$.75	3.85	" " "	94.75
16	24	1.2	2.1	2.45	Three lugs and links.	65.1
17	24	1.2	2.1	2.45	Two lugs and links.	65.

TABLE XXVIII.

FLANGES AND BOLTS.

No.	FLANGES.			BOLTS.		
	Thickness. Inches.	Effective Breadth. Inches.	Effective Area. Inches.	No. to each Joint.	Diameter. Inches.	Total Tensile Strength. Pounds.
12	$\frac{11}{16}$	2.8	1.92	4	$\frac{5}{16}$	16,000
13	$\frac{11}{16}$	2.75	1.89	4	$\frac{5}{16}$	16,000
14	$\frac{15}{16}$	2.75	2.58	4	$\frac{5}{16}$	16,000
15	$\frac{15}{16}$	2.5	2.34	4	$\frac{3}{8}$	20,000

BY TESTING MACHINE.

Tensile strength of cast-iron = 19,600 pounds per square in.
 Transverse strength of cast-iron = 46,600 pounds per square in.
 Tensile strength of $\frac{5}{16}$ bolts = 4,000 pounds.
 Tensile strength of $\frac{3}{8}$ bolts = 5,000 pounds.

TABLE XXVIX.

FAILURE OF FLANGED JOINTS.

No.	Area of Rim Square Inches.	Effect Area flanges. Sq. Ins.	Total Strength Bolts. Pounds.	Bursting Speed.		Cent. Tension.		REMARKS.
				Rev. per Min.	Ft. per Sec. = v	Per Sq. In. $=\frac{v^2}{10}$	Total Lbs.	
11	3.18	3,672	385	14,800	47,000	Solid rim.
12	3.85	1.92	16,000	Flange broke.
13	3.85	1.89	16,000	1,760	184	3,400	13,100	Flange broke.
14	3.85	2.58	16,000	1,875	196	3,850	14,800	Bolts broke.
15	3.85	2.34	20,000	1,810	190	3,610	13,900	Flange broke.

TABLE XXX.

LINKED JOINTS.

No.	LUGS.			LINKS.				RIM.	
	Breadth, Inches.	Length, Inches.	Area, Sq. In.	Number Used.	Effect Breadth. Inches.	Thickness, Inches.	Effective Area, Sq. Ins.	Max. Area, Sq. Ins.	Net Area, Sq. Ins.
16	.45	1.0	.45	3	.57	.327	.186	2.45	1.98
17	.44	.98	.43	2	.54	.380	.205	2.45	1.98

BY TESTING MACHINE.

Tensile strength of cast-iron =19,600.

Transverse strength of cast-iron=40,400.

Av. tensile strength of each link=10,180.

TABLE XXXI.

FAILURE OF LINKED JOINTS.

No.	Strength of Links, Pounds.	Strength of Rim, Pounds.	BURSTING SPEED.		CENT. TENSION.		REMARKS.
			Rev. per Min.	Ft. per Sec. = v	Per Sq. In. $\frac{v^2}{10}$	Total.	
16	30,540	38,800	3,060	320	10,240	25,100	Rim broke.
17	20,360	38,800	2,750	290	8,410	20,600	Lugs and Rim broke.

The flanged joints mentioned had the internal flanges and bolts common in large belt wheel rims while the linked joints were such as are common in fly-wheels not used for belts.

* Subsequent experiments have given approximately the same results as those just detailed. The highest velocity yet attained has been 424 feet per second ; this is in a solid cast-iron rim with numerous steel spokes. The average bursting velocity for solid cast rims with cast spokes is 400 feet per second.

Wheels with jointed rims burst at speeds varying from 190 to 250 feet per second, according to the style of joint and its location. The following general conclusions seem justified by these tests.

1. Fly-wheels with solid rims, of the proportions usual among engine builders and having the usual number of arms, have a sufficient factor of safety at a rim speed of 100 feet per second if the iron is of good quality and there are no serious cooling strains.

In such wheels the bending due to centrifugal force is slight, and may safely be disregarded.

* See Trans. Am. Soc. Mech. Eng., Vol. XXIII.

2. Rim joints midway between the arms are a serious defect and reduce the factor of safety very materially. Such joints are as serious mistakes in design as would be a joint in the middle of a girder under a heavy load.

3. Joints made in the ordinary manner, with internal flanges and bolts, are probably the worst that could be devised for this purpose. Under the most favorable circumstances they have only about one-fourth the strength of the solid rim and are particularly weak against bending.

See Fig. 79, which shows the opening of such a joint and the bending of the bolts.

In several joints of this character, on large fly-wheels, calculation has shown a strength less than one-fifth that of the rim.

4. The type of joint known as the link or prisoner joint is probably the best that could be devised for narrow rimmed wheels not intended to carry belts, and possesses, when properly designed, a strength about two-thirds that of the solid rim.

In 1902-04 experiments on four-foot pulleys were conducted by the writer, and the results published.*

A cast-iron, whole rim pulley 48 inches in diameter, burst at 1100 rev. per min. or a linear speed of 230 ft. per sec., the rupture being caused by a balance weight of $3\frac{1}{2}$ pounds which had been riveted inside the rim by the makers. The centrifugal force of this weight at 1100 rev. per min. was 2760 lb.

A cast iron split pulley of the same dimensions burst at a speed of about 600 rev. per min., or a linear speed of only 125 ft. per sec.

The failure was due to the unbalanced weight of the

* Trans. Am. Soc. Mech., Eng., Vol. XXVI,

joint flanges and bolts which were located midway between the arms. Such a pulley is not safe at high belt speeds.

84. Wooden Pulleys. Experiments on the bursting strength of wooden pulleys were conducted at the Case School laboratories in 1902-3 under the writer's direction.*

These are of some interest in view of the use of this material for fly-wheel rims. As noted in Art. 82, the tensile stress in wood due to the centrifugal force is only $\frac{1}{10}$ that of cast-iron under similar circumstances. Assuming the tensile strength of the wood to be 10000 lbs. per sq. in., and substituting this value in the equation $S = \frac{v^2}{100}$ we have the bursting speed of a wooden pulley $v=1000$ ft. per sec. nearly.

This for wood without joints.

The 24 inch pulleys tested had wood rims glued up in the usual manner and jointed at two opposite points. The wheels burst at speeds varying from 1700 to 2450 rev. per min., or linear rim speeds varying from 178 to 257 ft. per sec., thus comparing favorably with cast iron split pulleys. The rims usually failed at the points where the arms were mortised in, and the stiffening braces at these points did more harm than good. A wooden pulley with solid rim and web remained intact at 4450 rev. per min., or 467 ft. per sec., a higher speed than that of any cast-iron pulley tried.

85. Rims of Cast-Iron Gears. A toothed wheel will burst at a less speed than a pulley because the teeth

* Machinery, N. Y., Aug., 1905.

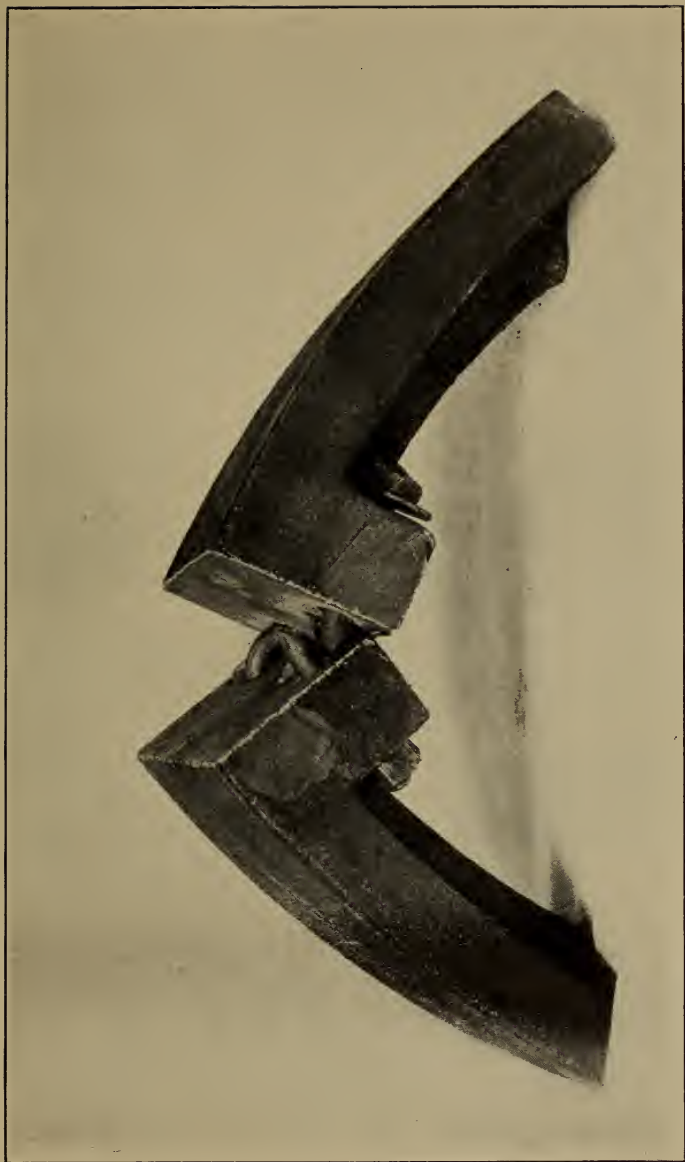

FIG. 79.—OPENING OF RIM JOINT AT HIGH SPEED.

increase the weight and therefore the centrifugal force without adding to the strength.

The centrifugal force and therefore the stresses due to the force will be increased nearly in the ratio that the weight of rim and teeth is greater than the weight of rim alone.

This ratio in ordinary gearing varies from 1.5 to 1.7. We will assume 1.6 as an average value. Neglecting bending we now have from equation (89)

$$S = 1.6 \times \frac{12wv^2}{g} = \frac{19.2wv^2}{g} \dots \dots \dots (95)$$

and
$$v = \sqrt{\frac{gS}{19.2w}}$$

$$= 326.2 \text{ ft. per second} \dots \dots (96)$$

Including bending

$$S' = 1.6v^2 \left(\frac{D}{tn_2} + \frac{1}{10} \right) \dots \dots \dots (97)$$

As the transverse strength of cast iron by experiment is about double the tensile strength, a larger value of *S* may be allowed in formulas (93) (94) and (97.)

In built up wheels it is better to have the joints come near the arms to prevent the tendency of the bending to open the joints, and the fastenings should have the same tensile strength as the rim of the wheel.

86. Rotating Discs. The formulas derived in Art. 82 will only apply in the case of thin rims and cannot be used for discs or for rims having any considerable depth. The determination of the stresses in a rotating disc is a complicated and difficult problem, if the material is regarded as perfectly elastic.

A rational solution of this problem may be found in Stodola's Steam Turbines, pp. 157-69. For the pur-

poses of this treatise an approximate solution is preferred, the elasticity of the metal being neglected. This method of treatment is much simpler, and as the metals used are imperfectly elastic (especially the cast metals) the results obtained will probably be as reliable as any—for practical use.

The following discussion is an abstract of one given by Mr. A. M. Levin in the American Machinist* the notation being changed somewhat.

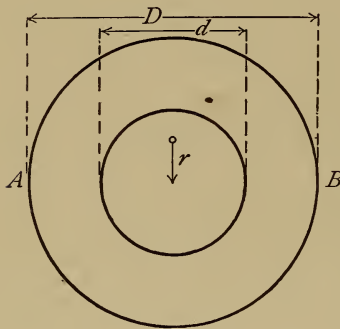

Fig. 80.

87. Plain Discs.

Let Fig. 80 represent a ring of uniform thickness t , having an external diameter D and an internal diameter d , all in inches.

Let v = external velocity in feet per second.

$$\text{Let } a = \text{angular velocity} = \frac{2\pi v}{D}.$$

r = radius to center of gravity of half ring in feet.

w = weight of metal per cubic inch.

The value of r for a half-ring is easily proved to be :

$$\frac{2}{3\pi} \cdot \frac{D^3 - d^3}{D^2 - d^2} \text{ in inches}$$

or
$$r = \frac{1}{18\pi} \cdot \frac{D^3 - d^3}{D^2 - d^2} \text{ in feet.}$$

* American Machinist, Oct. 20, 1904.

The weight of the half-ring is :

$$W = \frac{\pi}{8}(D^2 - d^2)tw$$

and its centrifugal force :

$$C = \frac{Wa^2r}{g} = \frac{a^2tw(D^3 - d^3)}{144g} \dots \dots \dots (98)$$

Substituting for a its value in terms of v :

$$C = \frac{4twv^2(D^3 - d^3)}{gD^2} \dots \dots \dots (99)$$

Now if we assume the stress on the area at AB due to the centrifugal force to be uniformly distributed : (and here lies the approximation) then will the tensile stress on the section be

$$S = \frac{C}{(D-d)t} = \frac{4wv^2(D^2 + Dd + d^2)}{gD^2} \dots \dots (100)$$

For a solid disc :

$$S_{d=0} = \frac{4wv^2}{g} \dots \dots \dots (101)$$

For a thin ring :

$$S_{d=D} = \frac{12wv^2}{g} \dots \dots \dots (102)$$

on the same as in equation (89).

If the metal be perfectly elastic, Stodola's formulas give $S = \frac{9wv^2}{g}$ as the stress near the center when d approaches 0— or more than twice the value given in (101). In view of the imperfect elasticity of the metals used the true value will probably be between these two. This value should be determined by experiment.

88. **Conical Discs.** Let Fig. 81 represent a ring whose thickness varies uniformly from the inner to the outer circumference and whose dimensions are as follows :

D = outer diameter in inches.

d = inner diameter “

b = breadth of ring at inner circumference.

m = tangent of angle of slant CAD .

Then $m = \frac{D-d}{b}$ or $b = \frac{D-d}{m}$.

By cutting the ring into slices perpendicular to the

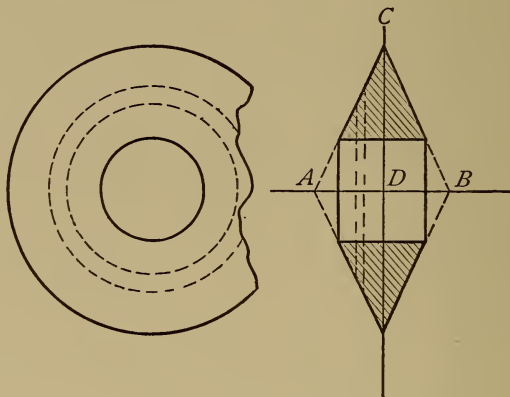

Fig. 81.

axis, finding the centrifugal force for each slice and then integrating between D and d , the centrifugal force of the half-ring is found to be :

$$C = \frac{wv^2(D^4 + 3d^4 - 4Dd^3)}{mgD^2} \dots \dots \dots (103)$$

The area on the line AB to resist the centrifugal force is : $\frac{(D-d)^2}{2m}$ and $S = \frac{2wv^2(D^4 + 3d^4 - 4Dd^3)}{gD^2(D-d)^2}$. (104)

When $d=0$:

$$S = \frac{2wv^2}{g} \dots \dots \dots (105)$$

or a stress one-half that of a plain flat disc.

89. Discs with Logarithmic Profile. A form of disc sometimes used for steam turbines consists of a solid of revolution generated by a curve of the equation

$$y = a \log \frac{x}{b}$$

revolving around the x -axis.

Mr. Levin investigates two curves of this character :

$$y = \log x \text{ and } y = 2 \log \frac{x}{3}$$

and finds the stresses to be respectively :

$$\text{When } a=b \quad S = 1.5 \frac{wv^2}{g} \dots \dots \dots (106)$$

$$\text{When } a = \frac{2}{3}b \quad S = 1.2 \frac{wv^2}{g} \dots \dots \dots (107)$$

The general equation for S in this case is :

$$S = 96 \frac{wv^2}{g} \cdot \frac{\alpha^2}{D^2} \dots \dots \dots (108)$$

and in deriving the formulas (106) and (107) D is assumed as $8a$ and as $9a$ respectively.

90. Bursting Speeds. It will be seen that all the formulas for centrifugal stress may be reduced to the general form :

$$S = k \frac{wv^2}{g} \dots \dots \dots (109)$$

where k is a constant depending upon the shape of the rotating body.

The following table gives the values of $v = \sqrt{\frac{gS}{kw}}$, the bursting speed of iron in feet per second, for different materials and different shapes.

TABLE XXXII.
BURSTING SPEEDS IN FEET PER SECOND.

Metal.	Weight per Cubic Inch.	Tensile Strength.	Values of v .				
			Thin Ring.	Perforated Disc (Stodola).	Flat Disc.	Taper Disc.	Logar- ithmic Disc.
	w	S	$k=12$	$k=9$	$k=4$	$k=2$	$k=1.5$
Cast Iron..026	18000	430	500	745	1050	1215
Manganese Bronze	.0315	60000	715	825	1240	1750	2050
Soft Steel.....	.028	60000	760	880	1315	1860	2140

PROBLEMS.

1. Determine bursting speed in revolutions per minute, of a gear 48 inches in diameter with six arms, if the thickness of rim is .75 inch.

(1) Considering centrifugal tension alone.

(2) Including bending of rim due to centrifugal force assuming that $\frac{3}{4}$ the stress due to bending is relieved by the stretching of the arms.

2. Design a link joint for the rim of a fly-wheel, the rim being 8 in. wide, 12 in. deep and 18 ft. mean diameter, the links to have a tensile strength of 65000 lb. per sq. in. Determine the relative strength of joint and the probable bursting speed.

3. Discuss the proportions of one of the following wheels in the laboratory and criticise dimensions.

- (a) Fly-wheel, Allis engine.
- (b) Fly-wheel, Fairbanks gas engine.
- (c) Fly-wheel, air compressor.
- (d) Fly-wheel, Ball engine.
- (e) Fly-wheel, ammonia compressor.

4. Determine the value of C in formula (103) by calculation.

5. A Delaval turbine disc is made of soft steel in the shape of the logarithmic curve without any hole at the center. Determine the probable bursting speed if the disc is 8 inches in diameter.

6. A wheel rim is made of cast iron in the shape of a ring having diameters of $4\frac{1}{2}$ feet and 6 feet, inside and outside. Determine probable bursting speed.

7. Substitute the value for centrifugal force in place of internal pressure in Barlow's formula (b) Art. 12, and derive a value for S in a rotating ring. Test this for $d = \frac{D}{2}$ and compare with formulas in preceding article.

CHAPTER XII.

TRANSMISSION BY BELTS AND ROPES.

91. Friction of Belting. The transmitting power of a belt is due to its friction on the pulley, and this friction is equal to the difference between the tensions of the driving and slack sides of the belt.

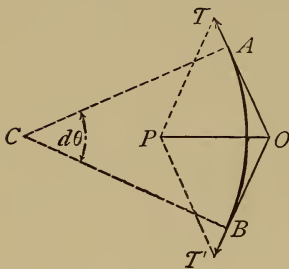

Fig. 82.

Let w = width of belt.

T_1 = tension of driving side.

T_2 = tension of slack side.

R = friction of belt.

$$= T_1 - T_2$$

f = coefficient of friction between belt and pulley.

θ = arc of contact in circular measure.

lar measure.

The tension T at any part of the arc of contact is intermediate between T_1 and T_2 .

Let AB Fig. 82 be an indefinitely short element of the arc of contact, so that the tensions at A and B differ only by the amount dT .

dT will then equal the friction on AB which we may call dR .

Draw the intersecting tangents OT and OT' to represent the tensions and find their radial resultant OP . Then will OP represent the normal pressure on the arc AB which we will call P .

$$\angle OTP = \angle ACB = d\theta$$

$$\therefore P = Td\theta$$

The friction on AB is

$$f P = f T d\theta$$

or

$$dT = dR = f T d\theta$$

and

$$f d\theta = \frac{dT}{T}$$

Integrating for the whole arc θ :

$$f\theta = \int_{T_2}^{T_1} \frac{dT}{T} = \log_e \frac{T_1}{T_2}$$

$$\frac{T_1}{T_2} = e^{f\theta}$$

$$T_2 = \frac{T_1}{e^{f\theta}} = T_1 e^{-f\theta}$$

$$R = T_1 - T_2 = T_1(1 - e^{-f\theta}) \dots \dots \dots (110)$$

The average value of f for leather belts on iron pulleys as determined by experiment is $f = 0.27$.

If we denote expression $(1 - e^{-f\theta})$ by C , then for different arcs of contact C has the following values :

Arc of Contact.	90°	110°	130°	150°	180°	210°	240°
C	.345	.404	.458	.506	.571	.627	.676

The friction or force transmitted by a belt per inch of width is then

$$R = C T_1 \dots \dots \dots (111)$$

and T_1 must not exceed the safe working tensile strength of the material.

A handy rule for calculating belts assumes $C = .5$ which means that the force which a belt will transmit

under ordinary conditions is one-half its tensile strength.

92. Strength of Belting. The strength of belting varies widely and only average values can be given. According to experiments made by the author good oak tanned belting has a breaking strength per inch of width as follows :

	Single.	Double.
Solid leather	900 lb.	1400 lb.
Where riveted.	600 lb.	1200 lb.
Where laced	350 lb.

Canvas belting has approximately the same strength as leather. Tests of rubber coated canvas belts 4-ply, 8 inches wide, show a tensile strength of from 840 lb. to 930 lb. per inch of width.

93. Taylor's Experiments. The experiments of Mr. F. W. Taylor, as reported by him in *Trans. Am. Soc. Mech. Eng.* Vol. XV. afford the most valuable data now available on the performance of belts in actual service.

These experiments were carried on during a period of nine years at the Midvale Steel Works. Mr. Taylor's conclusions may be epitomized as follows :

1. Narrow double belts are more economical than single ones of a greater width.

2. All joints should be spliced and cemented.

3. The most economical belt speed is from 4000 to 4500 ft. per min.

4. The working tension of a double belt should not exceed 35 lb. per inch of width, but the belt may be first tightened to about double this.

5. Belts should be cleaned and greased every six months.

6. The best length is from 20 to 25 feet between centers.

94. Rules for Width of Belts. It will be noticed that Mr. Taylor recommends a working tension only $\frac{1}{30}$ to $\frac{1}{40}$ the breaking strength of the belt. He justifies this by saying that belts so designed gave much less trouble from stoppage and repairs and were consequently more economical than those designed by the ordinary rules.

In the following formulas 50 lb. per inch of width is allowed for double belts and 30 lb. for single belts. These are suitable values for belts which are not running continuously. The formulas may be easily changed for other thicknesses and for other values of CT_1 .

Let HP =horse power transmitted.

D =diameter of driving pulley in inches.

N =no. rev. per min. of pulley.

The moment of force transmitted by belt is

$$\frac{RD}{2} = \frac{CT_1 w D}{2} = T$$

and

$$HP = \frac{TN}{63025} = \frac{CT_1 w DN}{126050} \dots (112)$$

Substituting the values assumed for CT_1 and solving for w :

$$\text{Single belts } w = 4200 \frac{HP}{DN} \dots (113)$$

$$\text{Double belts } w = 2500 \frac{HP}{DN} \dots (114)$$

The most convenient rules for belting are those which give the horse-power of a belt in terms of the surface passing a fixed point per minute.

$$\text{In formula (112)} \quad HP = \frac{CT_1 w DN}{126050}$$

we will substitute the following :

$$W = \text{width of belt in feet} = \frac{w}{12}$$

$$V = \text{velocity in ft. per min.} = \frac{\pi DN}{12}$$

$$\text{or} \quad HP = \frac{144CT_1 WV}{126050\pi}$$

Substituting values of C and T_1 as before and solving for WV = square feet per minute we have approximately :

$$\text{Single belts } WV = 90HP. \quad . \quad . \quad . \quad (115)$$

$$\text{Double belts } WV = 55HP. \quad . \quad . \quad . \quad (116)$$

95. Speed of Belting. As in the case of pulley rims, so in that of belts a certain amount of tension is caused by the centrifugal force of the belt as it passes around the pulley.

$$\text{From equation (89)} \quad S = \frac{12wv^2}{g}$$

where v = velocity in ft. per sec.
 w = weight of material per cu. in.
 S = tensile stress per sq. in.

To make this formula more convenient for use we will make the following changes in the constants :

Let V = velocity of belt in ft. per minute = $60v$.

w = weight of ordinary belting.

= .032 per cu. in.

S_1 = tensile stress per inch width, caused by centrifugal force.

= about $\frac{3}{18} S$ for single belts.

Then
$$v = \frac{V}{60}$$

$$S = \frac{16S_1}{3}$$

Substituting these values in (89) and solving for S_1

$$S_1 = \frac{V^2}{1610000} \dots \dots \dots (117)$$

The speed usually given as a safe limit for ordinary belts is 3000 ft. per min., but belts are sometimes run at a speed exceeding 6000 ft. per min.

Substituting different values of V in the formula we have :

$V = 3000$	$S_1 = 5.59$ lb.
$V = 4000$	$S_1 = 9.94$ lb.
$V = 5000$	$S_1 = 15.53$ lb.
$V = 6000$	$S_1 = 22.36$ lb.

The values of S_1 for double belts will be nearly twice those given above. At a speed of 5000 ft. per minute the maximum tension per inch of width on a single belt designed by formula (113), if we call $C = .5$, will be :

$$(30 \times 2) + 15. = 75 \text{ lb.}$$

giving a factor of safety of eight or ten at the splices.

In a similar manner we find the maximum tension per inch of width of a double belt to be :

$$(50 \times 2) + 30 = 130 \text{ lb.}$$

and the margin of safety about the same as in single belting.

A double belt is stiffer than a single one and should not be used on pulleys less than one foot in diameter. Triple belts can be used successfully on pulleys over 20 inches in diameter.

96. Manila Rope Transmission. Ropes are sometimes used instead of flat belts for transmitting power short distances. They possess the following advantages: they are cheaper than belts in first cost; they are flexible in every direction and can be carried around corners readily. They have however the disadvantage of being less efficient in transmission than leather belts and less durable; they are also somewhat difficult to splice or repair.

There are two systems of rope driving in common use: the English and the American. In the former there are as many separate ropes as there are grooves in one pulley, each rope being an endless loop always running in one groove.

In the American system one continuous rope is used passing back and forth from one groove to another and finally returning to the starting point.

The advantage of the English system consists in the fact that one of the ropes may fail without causing a breakdown of the entire drive, there usually being two or three ropes in excess of the number actually necessary. On the other hand the American system has the advantage of a uniform regulation of the tension on all the plies of rope. The guide pulley, which guides the last slack turn of rope back to the starting point, is usually also a tension pulley and can be weighted to secure any desired tension. The English

method is most used for heavy drives from engines to head shafts; the American for lighter work in distributing power to the different rooms of a factory. The grooves in the pulleys for manila or cotton ropes usually have their sides inclined at an angle of about 45° , thus wedging the rope in the groove.

The Walker groove has curved sides as shown in Fig. 83, the curvature increasing towards the bottom. As the rope wears and stretches it becomes smaller and sinks deeper in the groove; the sides of the groove being more oblique near the bottom, the older rope is not pinched so hard as the newer and this tends to throw more of the work on the latter.

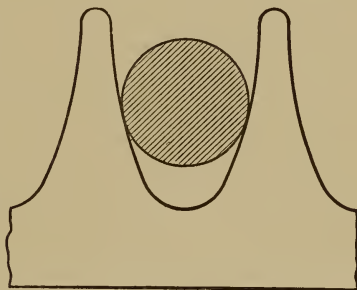

Fig. 83.

97. Strength of Manila Ropes. The formulas for transmission by ropes are similar to those for belts, the values for S and ϕ being changed. The ultimate tensile strength of manila and hemp rope is about 10000 lb. per sq. in.

To insure durability and efficiency it has been found best in practice to use a large factor of safety. Prof. Forrest R. Jones in his book on Machine Design recommends a maximum tension of $200 d^2$ pounds where d is the diameter of rope in inches. This corresponds to a tensile stress of 255 lb. per sq. in. or a factor of safety of about 40.

The value of f for manila on metal is about 0.12, but as the normal pressure between the two surfaces

is increased by the wedge action of the rope in the groove we shall have the apparent value of f :

$$f^1 = f \div \sin \frac{a}{2} \text{ where}$$

a = angle of groove,

For

$a = 45^\circ$ to 30°

f^1 varies from 0.3 to 0.5 and these values should be used in formula (110).

$(1 - e^{-f\theta})$ in this formula, for an arc of contact of 150° , becomes either .54 or .73 according as f^1 is taken 0.3 or 0.5.

If T_1 is assumed as 250 lb. per sq. in., the force R transmitted by the rope varies from 135 lb. to 185 lb. per sq. in. area of rope section.

The following table gives the horse-power of manila ropes based on a maximum tension of 255 lb. per sq. in.

TABLE XXXIII.

Table of the horse-power of transmission rope, reprinted from the transactions of the American Society of Mechanical Engineers, Vol. 12, page 230, Article on "Rope Driving" by C. W. Hunt.

The working strain is 800 lb. for a 2-inch diameter rope and is the same at all speeds, due allowance having been made for loss by centrifugal force.

Diameter Rope, Inches.	SPEED OF THE ROPE IN FEET PER MINUTE.										Smallest Diam. Pul- leys, Ins.
	1500	2000	2500	3000	3500	4000	4500	5000	6000	7000	
$\frac{3}{4}$	3.3	4.3	5.2	5.8	6.7	7.2	7.7	7.7	7.1	4.9	30
$\frac{7}{8}$	4.5	5.9	7.0	8.2	9.1	9.8	10.8	10.8	9.3	6.9	36
1	5.8	7.7	9.2	10.7	11.9	12.8	13.6	13.7	12.5	8.8	42
$1\frac{1}{4}$	9.2	12.1	14.3	16.8	18.6	20.0	21.2	21.4	19.5	13.8	54
$1\frac{1}{2}$	13.1	17.4	20.7	23.1	26.8	28.8	30.6	30.8	28.2	19.8	60
$1\frac{3}{4}$	18.0	23.7	28.2	32.8	36.4	39.2	41.5	41.8	37.4	27.6	72
2	23.1	30.8	36.8	42.8	47.6	51.2	54.4	54.8	50.0	35.2	84

98. **Wire Rope Transmission.** Wire ropes have been used to transmit power where the distances were too great for belting or hemp rope transmission. The increased use of electrical transmission is gradually crowding out this latter form of rope driving.

For comparatively short distances of from 100 to 500 yards wire rope still offers a cheap and simple means of carrying power.

The pulleys or wheels are entirely different from those used with manila ropes.

Fig. 84 shows a section of the rim of such a pulley. The rope does not touch the sides of the groove but rests on a shallow depression in a wooden, leather or rubber filling at the bottom. The high side flanges prevent the rope from leaving the pulley when swaying on account of the high speed.

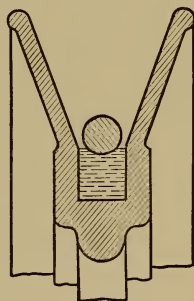

Fig. 84.

The pulleys must be large, usually about 100 times

the diameter of rope used, and run at comparatively high speeds. The ropes should not be less than 200 feet long unless some form of tightening pulley is used.—Table XXXIV. is taken from Roebing.

Long ropes should be supported by idle pulleys every 400 feet.

TABLE XXXIV.

TRANSMISSION OF POWER BY WIRE ROPE.

Showing necessary size and speed of wheels and rope to obtain any desired amount of power.

Diameter of Wheel in ft.	Number of Revolutions.	Diameter of Rope.	Horse-Power.	Diameter of Wheel in ft.	Number of Revolutions.	Diameter of Rope.	Horse-Power.
4	80	5-8	3.3	10	80	11-16	58.4
	100	5-8	4.1		100	11-16	73.
	120	5-8	5.		120	11-16	87.6
	140	5.8	5.8		140	11-16	102.2
5	80	7-16	6.9	11	80	11-16	75.5
	100	7-16	8.6		100	11-16	94.4
	120	7-16	10.3		120	11-16	113.3
	140	7-16	12.1		140	11-16	132.1
6	80	1-2	10.7	12	80	3-4	99.3
	100	1-2	13.4		100	3-4	124.1
	120	1-2	16.1		120	3-4	148.9
	140	1-2	18.7		140	3-4	173.7
7	80	9-16	16.9	13	80	3-4	122.6
	100	9-16	21.1		100	3-4	153.2
	120	9-16	25.3		120	3-4	183.9
8	80	5-8	22.	14	80	7-8	148.
	100	5-8	27.5		100	7-8	185.
	120	5-8	33.0		120	7-8	222.
9	80	5-8	41.5	15	80	7-8	217.
	100	5-8	51.9		100	7-8	259.
	120	5-8	62.2		120	7-8	300.

PROBLEMS.

1. Design a main driving belt to transmit 150 HP. from a belt wheel 18 ft. in diameter and making 80 rev. per min. The belt to be double leather without rivets.
2. Investigate driving belt on Allis engine and calculate the horse-power it is capable of transmitting economically.
3. Calculate the total maximum tension per inch of width due to load and to centrifugal force of the driving belt on the motor used for driving machine shop, assuming the maximum load to be 10 HP.
4. Design a manila rope drive, English system, to transmit 500 HP., the wheel on the engine being 20 feet. in diameter and making 60 rev. per min. Use Hunt's table and then check by calculating the centrifugal tension and the total maximum tension on each rope. Assume $S = \frac{v^2}{80}$ where $v =$ feet per second.
5. Design a wire rope transmission to carry 120 HP. a distance of one-quarter mile using two ropes. Determine working and maximum tension on rope, length of rope, diameter and speed of pulleys and number of supporting pulleys.

INDEX.

	ART.	PAGE.
ABBREVIATIONS.....	2	1
ADJUSTMENT OF BEARINGS.....	43	96
ALLOYS.....	3	4
ARMS OF PULLEYS.....	77	157
BALL BEARINGS,		
In general.....	57	118
Conical.....	58	119
Cylindrical.....	58	118
Design of.....	61	123
Materials of.....	60	122
Step or thrust.....	59	120
BEAMS, formulas for.....	5	12
Of uniform strength.....	6	12
BEARINGS,		
Adjustment of.....	43	96
Ball.....	57	118
Cylindrical.....	42	96
Engine.....	43	97
Lathe.....	43	98
Lubrication of.....	44	99
Roller.....	62	123
Sliding.....	36	86
Step or thrust.....	51	111
Thrust.....	56	116
BELTING,		
Centrifugal tension of.....	95	189
Friction of.....	91	184
Speed of.....	95	188
Strength of.....	92	186
Taylor's experiments on.....	93	186
Width of.....	94	187
BOILER SHELLS.....	11	25
Tubes.....	14	38

	ART.	PAGE.
BOLTS,		
Coupling.....	69	138
Dimensions of.....	18	54
Eye or hook.....	20	57
BRONZES.....	3	5
BUTT JOINTS.....	23	62
CABINET SUPPORTS.....	9	19
CAPS AND BOLTS.....	50	109
CAST IRON.....	3	3
CENTRIFUGAL OILERS.....	44	101
CHAIN DRIVING,		
Block.....	78	159
Roller.....	78	160
Silent.....	79	161
CLUTCHES,		
Conical.....	68	137
Roller.....	68	138
Weston.....	68	136
COLLAR BEARING.....	53	113
Compound.....	56	116
COLUMN FORMULAS.....	5	9
CONSTANTS,		
Columns.....	5	10
Cross-sections.....	5	11
COTTERS.....	29	69
COUPLINGS,		
Bolts for.....	69	138
Clutch.....	68	135
Flange.....	67	133
Muff.....	67	135
Sleeve.....	67	134
CRANKS.....	80	163
CRANK PINS,		
Heating of.....	47	104
Pressure on.....	46	103
CROSS-SECTIONS.....	10	21
CYLINDERS,		
Hydraulic.....	12	27
Steam.....	16	42
DESIGN, GENERAL PRINCIPLES OF.....	8	15
DISCS, ROTATING.....	86	177

	ART.	PAGE.
DISC,— <i>Continued.</i>		
Conical.....	88	180
Logarithmic.....	89	181
Plain.....	87	178
Speeds of.....	90	181
FACTORS OF SAFETY.....	7	13
FLAT PLATES,		
Formulas for.....	17	48
Tests of.....	17	51
FLY WHEELS.....	81	166
Experiments on.....	83	170
Rim Joints of.....	83	175
Safe Speed of.....	82	167
FLUES, STRENGTH OF.....	14	38
FORMULAS, GENERAL.....	5	8
FRAME DESIGN.....	10	20
FRICTION,		
Belts.....	91	184
Journals.....	45	102
Experiments on.....	48	107
Pivots.....	52	112
Schiele pivot.....	55	114
GEARS,		
Arms of.....	77	157
Rims of.....	77	157
Teeth of.....	72	146
GIBS.....	28	72
“.....	38	89
GUIDES, CIRCULAR.....	40	91
HANGERS.....	71	141
HEATING OF JOURNALS.....	47	107
HOOKS, DESIGN OF.....	20	57
IRON,		
Cast.....	3	3
Malleable.....	3	4
Wrought.....	3	2
JOINTS,		
Butt.....	23	62
Lap.....	22	61
Riveted.....	21	58
JOINT PINS.....	28	69

	ART.	PAGE.
JOURNALS	42	96
Experiments on.....	48	107
Friction of.....	45	102
Heating of	47	104
Pressure on.....	46	103
Strength of.....	49	108
KEYS,		
Cotter.....	28	69
Shafting.....	70	139
Woodruff.....	70	141
LAP JOINTS.....	22	61
LEGS OF MACHINES.....	9	19
LEVERS.....	80	163
LUBRICATION OF BEARINGS	44	99
MACHINE FRAMES.....	10	20
MALLEABLE IRON	3	4
MATERIALS OF CONSTRUCTION.....	3	2
NOTATION.....	4	8
OIL CUPS.....	44	100
PACKINGS FOR GLANDS.....	41	92
PIPE,		
Sizes.....	13	30
Fittings.....	15	40
PIVOTS,		
Conical.....	54	113
Flat.....	52	112
Schiele.....	55	114
PLATES,		
Flat.....	17	48
Narrow.....	27	68
PRESSURE ON JOURNALS.....	46	103
PULLEYS,		
Arms of.....	77	157
Cast Iron.....	83	175
Wooden.....	84	176
RING OILER.....	44	101
RIVETED JOINTS	21	58
Efficiency of.....	24	62
Narrow Plates	27	68
Practical rules for.....	26	64
Special forms of.....	25	63

	ART.	PAGE.
ROLLER BEARINGS,		
Conical	63	124
Cylindrical.....	62	123
Hyatt.....	64	125
Step	65	127
Tests of	64	126
ROPE, TRANSMISSION,		
Manila.....	96	190
Strength of.....	97	191
Wire.....	98	193
SCHIELE PIVOT.....	55	114
SCREWS, MACHINE.....	19	57
SHAFTING,		
Diameter of.....	66	132
Keys for....	70	139
Span of....	66	133
Strength of.....	66	130
SHELLS, STRENGTH OF,		
Thick.....	12	27
Thin.....	11	25
SLIDES,		
Angular.....	37	87
Flat.....	39	89
Gibbed.....	38	88
SPRINGS,		
Elliptic.....	35	83
Flat.....	34	81
Helical.....	30	73
Square wire.....	31	75
Tests of.....	32	76
Torsion.....	33	79
STEAM CYLINDERS,		
Strength of.....	16	42
Tests of.....	16	45
STEEL.....	3	3
STRENGTH OF METALS,		
Cast.....	3	7
Wrought.....	3	6
STUFFING BOXES.....	41	91
SUPPORTS, MACHINE.....	9	18

	ART.	PAGE.
TEETH OF GEARS,		
Bevel.....	76	155
Cut.....	73	150
Experiments on....	75	153
Lewis' formula for.....	74	151
Proportions of.....	72	148
Strength of....	73	148
Velocity of	74	152
THRUST BEARING.....	56	116
TUBES, BOILER.....	14	38
UNITS AND DEFINITIONS.....	1	1
WROUGHT IRON.....	3	2

Hall's College Laboratory Manual of Physics

By EDWIN H. HALL, Professor of Physics in Harvard University. viii + 138 pp. 12mo. 80 cents.

A collection of exercises which have been used by the author as a laboratory accompaniment to his general course of lectures and text-book study extending through one college year.

Echols's Differential and Integral Calculus

By W. H. ECHOLS, Professor in the University of Virginia. x + 480 pp. 8vo. \$2.00.

This text is designed to meet the needs of the undergraduate work in American universities. The treatment is elementary and clear. The subject is developed continuously and is based on the Law of the Mean Value.

Alfred Baker, Professor in the University of Toronto:—I find it an admirable text-book. The printing is good, the explanations clear and concise, and the examples numerous, illustrative, and full of suggestiveness.

McMullen's Forty Lessons in Physics

By LYNN B. McMULLEN, Shortridge High School, Indianapolis. viii + 452 pp. 12mo. \$1.25.

A departure from the traditional school text-book of physics. It takes the *pupil* into account, recognizing his limitations of capacity and interest. It selects the fundamentals within his grasp, treats these fully enough to permit mastery, and requires him to apply his knowledge at once to everyday phenomena. It is not a cyclopedia or laboratory manual, but first and last a text-book—orderly, clear, and vivid.

Its originality is reflected in its typographical arrangement. The left-hand pages, 226 in number, are devoted solely to a systematic presentation of principles, and to simple problems in application. The right-hand pages contain (1) illustrations, modeled on note-book drawings; (2) formulas, with their derivation; (3) tables and other supplementary matter.

HENRY HOLT AND COMPANY
NEW YORK CHICAGO

CHEMISTRY

Cairns's Quantitative Chemical Analysis

Revised and enlarged by Dr. E. WALLER. 417 pp. 8vo. \$2.00, *net*.

Cohen's Physical Chemistry for Biologists

Translated by Dr. MARTIN FISCHER, Chicago University. 343 pp. 12mo., \$1.75, *net*.

Congdon's Qualitative Analysis

By Prof. ERNEST A. CONGDON, Drexel Institute. 64 pp. *Interleaved*. 8vo. 60c., *net*.

Nicholson and Avery's Exercises in Chemistry

With Outlines for the Study of Chemistry. To accompany any elementary text. By Prof. H. H. NICHOLSON, University of Nebraska, and Prof. SAMUEL AVERY, University of Idaho. 413 pp. 12mo. 60c., *net*.

Noyes's (A. A.) General Principles of Physical Science

An Introduction to the Study of the Principles of Chemistry. By Prof. A. A. NOYES, Mass. Institute of Technology. 160 pp. 8vo. \$1.50, *net*.

Noyes's (W. A.) Organic Chemistry

By Prof. WM. A. NOYES, Rose Polytechnic Institute. 534 pp. 12mo. \$1.50, *net*.

Qualitative Analysis (Elementary)

x + 91 pp. 8vo. 80c., *net*.

Remsen's Chemistries

By Pres. IRA REMSEN, Johns Hopkins. (*American Science Series*.)

Inorganic Chemistry (*Advanced*). xxii + 853 pp. 8vo. \$2.80, *net*.

College Chemistry xx + 689 pp. 8vo. \$2.00, *net*.

Introduction to Chemistry (*Briefer*). xxiv + 520 pp. 12mo. \$1.12, *net*.

This book is used in hundreds of schools and colleges in this country. It has passed through several editions in England, and has been translated into German (being the elementary text-book in the University of Leipsic), French, and Italian.

Remsen and Randall's Experiments (*for the "Introduction"*). 50c., *net*.

Elements of Chemistry (*Elementary*). x + 272 pp. 12mo. 80c., *net*.

Laboratory Manual (*for the "Elements"*). 40c., *net*.

Torrey's Elementary Chemistry

By JOSEPH TORREY, Jr., Harvard. 437 pp. 12mo. \$1.25, *net*.

White's Qualitative Analysis

By Prof. JOHN WHITE, Univ. of Nebraska. 96 pp. 8vo. 80c., *net*.

Woodhull and Van Arsdale's Chemical Experiments

By Prof. JOHN F. WOODHULL and M. B. VAN ARSDALE, Teachers' College, New York City. 136 pp. 12mo. 60c., *net*.

Extremely simple experiments in the chemistry of daily life.

HENRY HOLT & CO. 29 West 23d Street, New York
378 Wabash Avenue, Chicago

viii, '05

DEC 1 1906

LIBRARY OF CONGRESS



0 021 225 321 2